

proper botkiller routine combine
sad lychee d cluster postamnesia
, , , not the vague , , ,
sapphire k = new
_____ binary meme summer
detect casting humus pate root
neglect govs licensed hoarding
rear tags +pos+ to metavampire boost

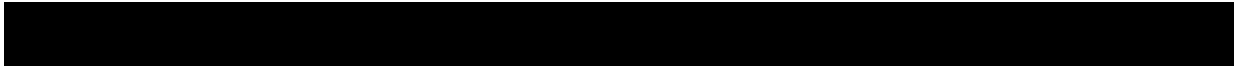

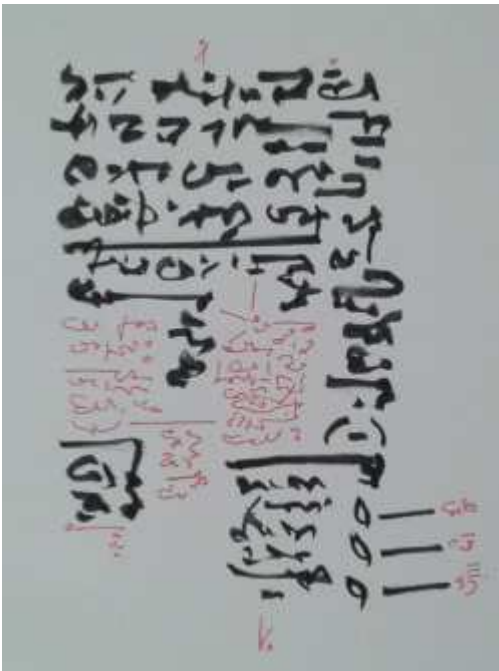



x offline hegel disrespect
_x spaced warp command at 12
__x nodewoofers august no sigh
___k redundancy wheelloop
____q obstupescit mundus
_____x looking at such westwondrous
____x





·
european skull refrain
skull & elbow
ewrope w_ent ent_h_ropey
refrain=== |||||
found after. |||||
sought after. |||||
over & +over |||||
===fou ||||
getget |||||
○ so get yours.
pickit from the pit. ckit.
plugin provided. refref.
tick of the ring. octet, stringwearers.
piss off the mark.
blackbench. full of glyphs.
iphone greek urls. greek font.
bold. underline. psychiatric

0 notes

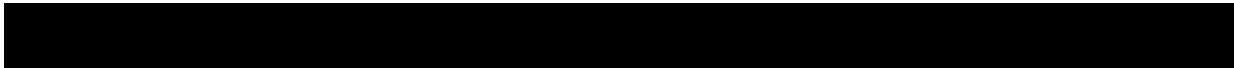

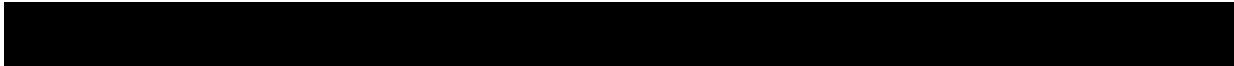
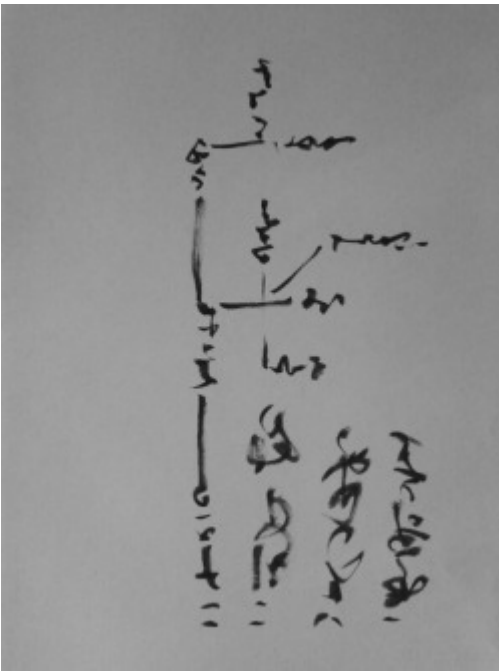

immortal ode

odin soup camp lapis
fou ride-or-slack ten pastillas
ur plastic urge unfax claim
bee by the riverside
not from this beer one
will tell



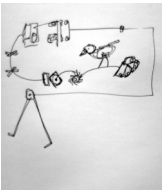
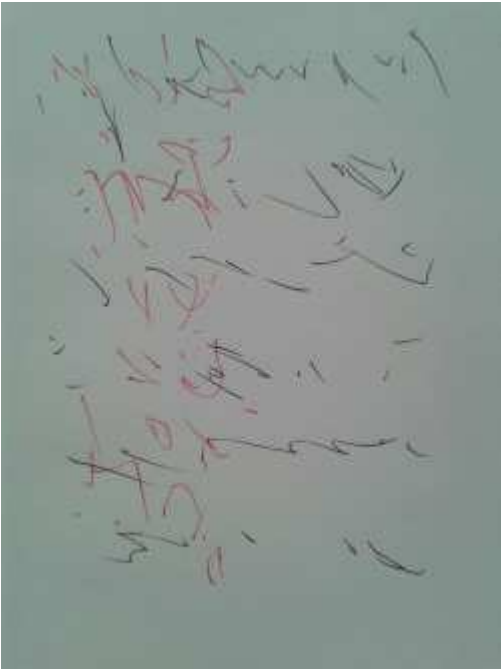

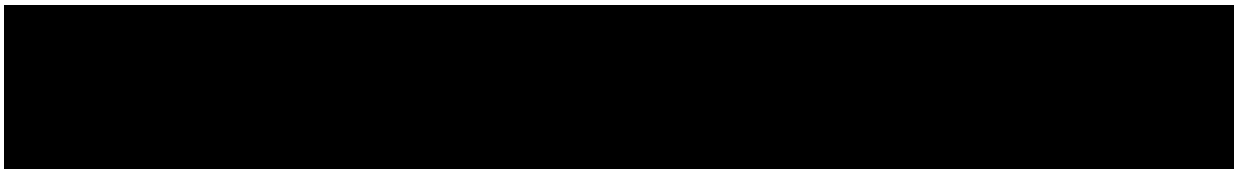

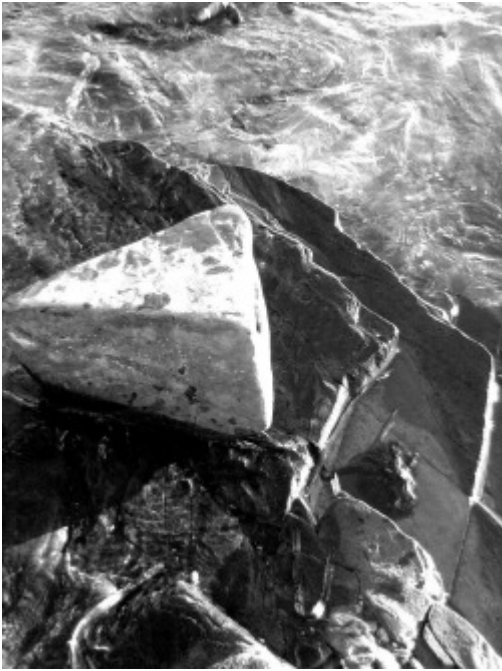

sadly x cafe soo x substitute
mechanic burst x ediph x usher fable x
determine what x determines



Handwritten text in Urdu script, possibly a signature or a short message, written vertically.

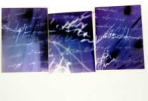

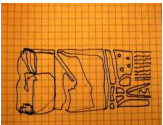
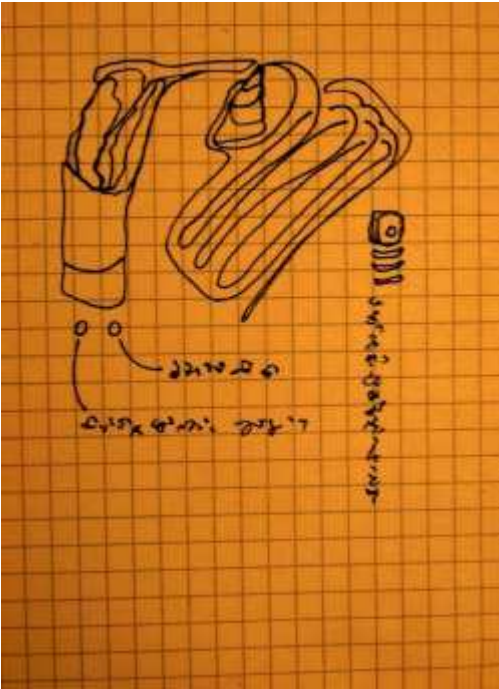

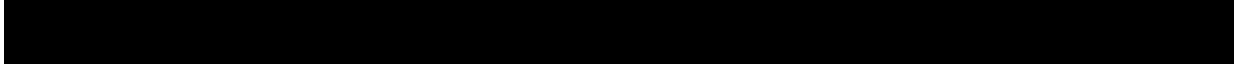

.
am not a thing, rain machine }
soothe the brown panel signifying
hens

=
ooooooooo ab

listed ab

=

neon abrupt theory mentioned 'the hush' _as_ #tagged^owner □ policdomino isn't involved □ people are*** involved □
you own your island, your island owns you □ hires penthouse ghost @ lunch □ unpin if dissatisfied □ uncheck/check □
prune extra math to the poor □ joe sued hey joe □ i can't ident □ plasma dolls want to please the plasma fog □ guerrilla
flags how i like them □ statement □
full }

.



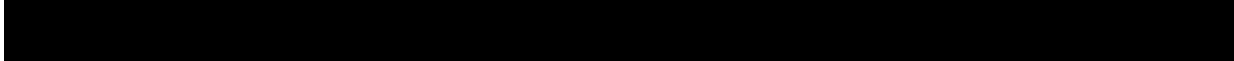
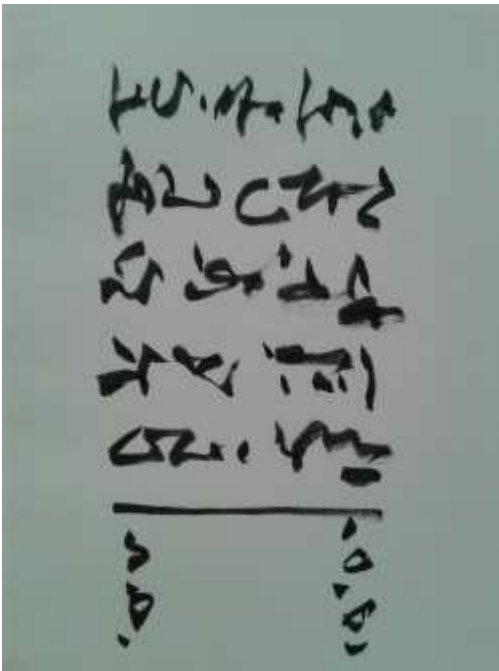

- oneday on.
- septic future apart. one
- diy. onday th will be:
- all the stuff in one place
- free
- people will enjoy the whole and the single pieces
- at the very same time
- a superflickr aleph
- ominously hovering
- above us western knitters
- mainly
-

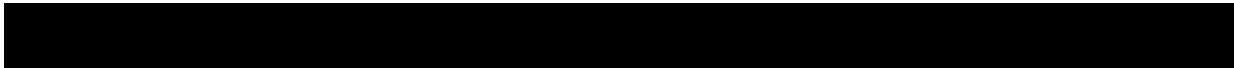

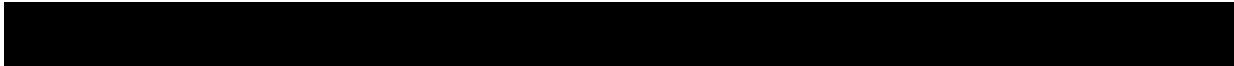
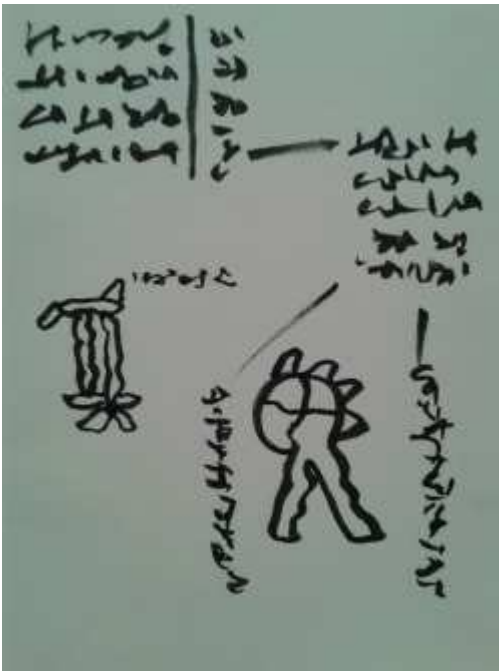

serendipity-shaped field of chronowoofer, after, lapis niger, ought, zebra talks are tweed ones, steady, phantasmata, peeled cottonvase, after, chew past the loop, tweet twice, apnea twins, good at tennis, field of rain, it rains, after a whole day, under, ought, after a while, it rains, the movie ain't over, brought back, so, move then, open, dot, theory, do not, simplest, cause, diverge

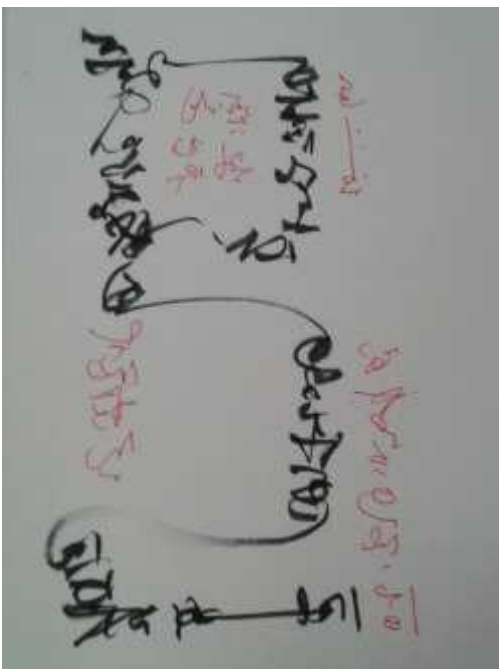

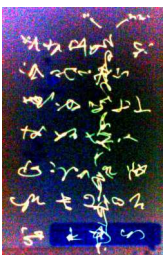
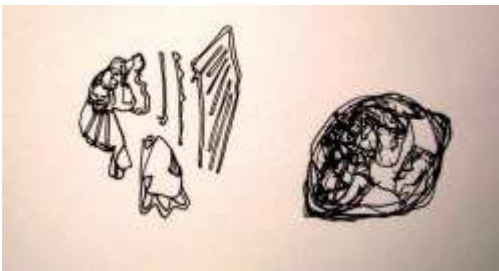

5. Ciotola in impasto
6. Piatti in impasto grezzo
7. Tromba-lituo in bronzo
8. Scudo in bronzo
9. Ascia in bronzo

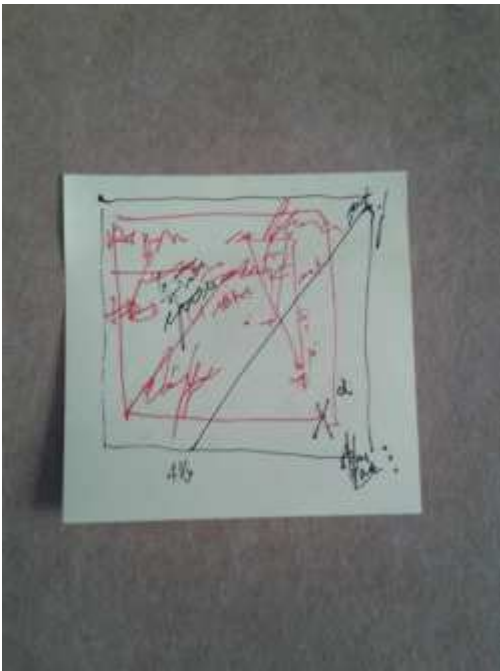

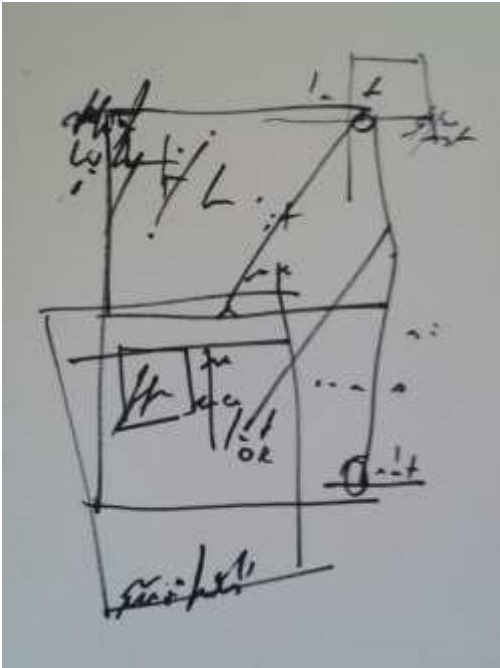
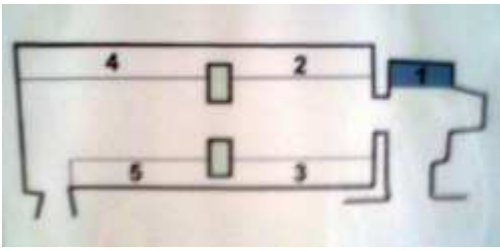

Il delicato recupero dello scheletro



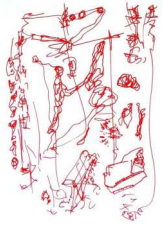
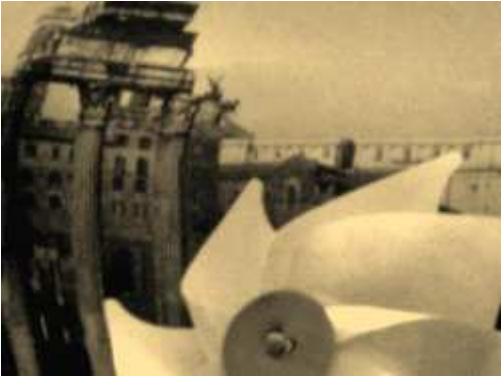



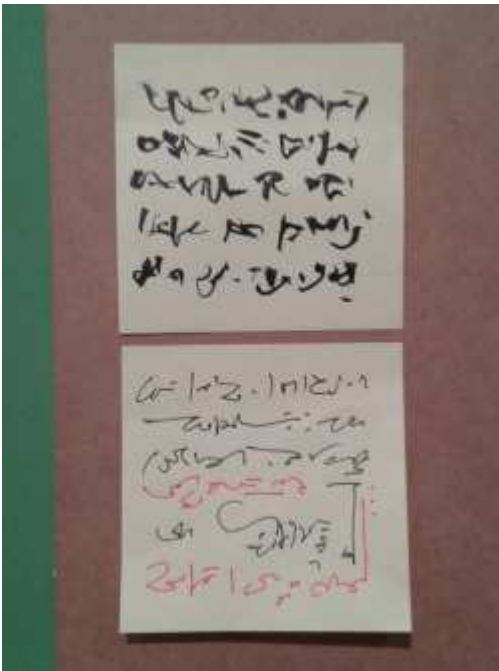

per sidera — not anatomy
— and contextual ^ shm on its air
fabula. swipe to. not. the sound ph.
bisogna comprare.
il faut ~» on est compelled to.

by



sk

taly's at stake. steak of taly. partake. stop mou-
ghoauls—
= nothing new
peach dopamine plutarch means fossil means
dust nailbed dagon rug. onions fate dome at.
sight cinderella. comma. do not.

vintage laws fix the bug. human what?
skip to play WESTWARD
now

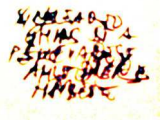

25h7h
louvre-shaped apricot. takes off. been the real fear. fx.
couldn't imagine the task. glass garden // ***reptile***.
along the mockriver.
sedate the crow.
not a series. casefree.



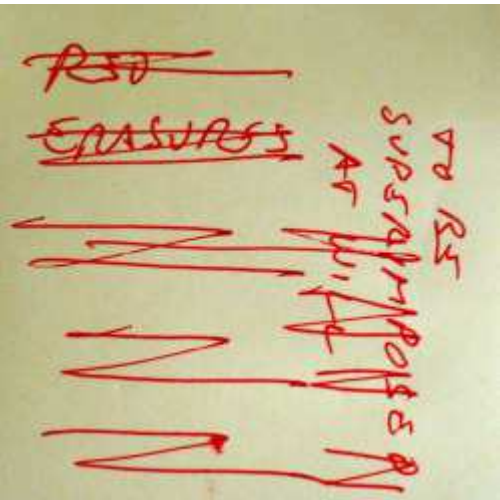

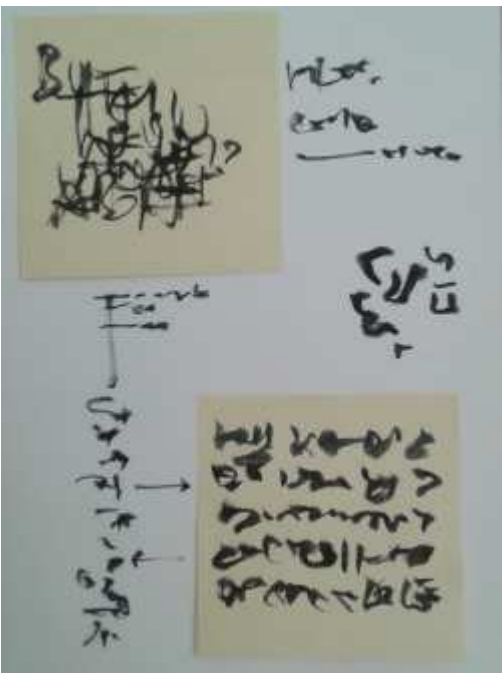



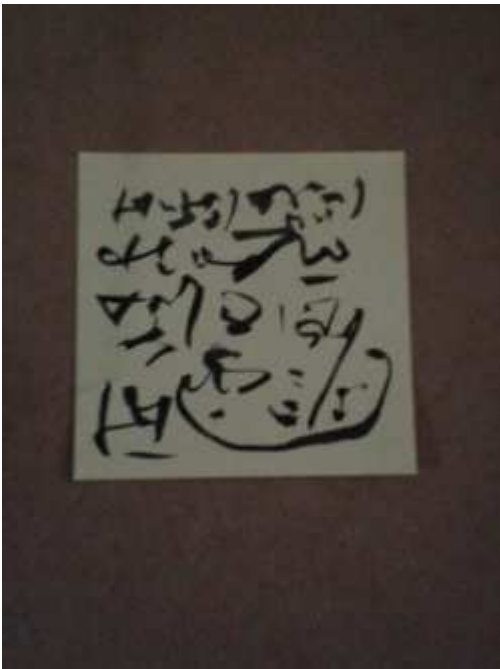



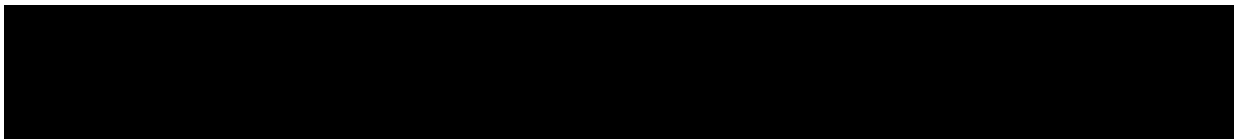
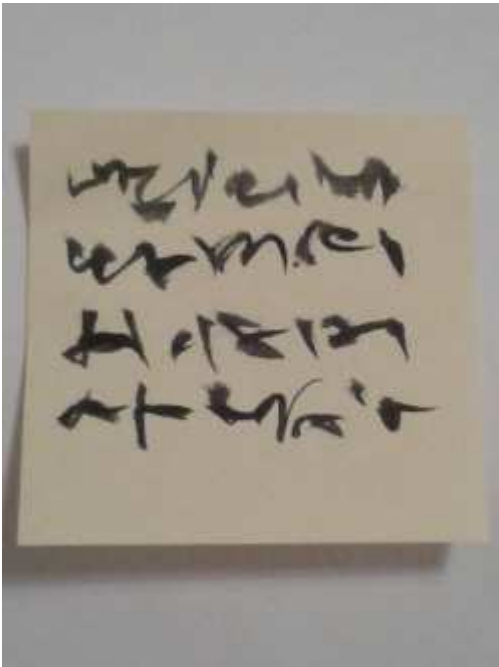





= Torquato Tasso, Jerusalem Delivered, I, I-IV =

1. Where beheld,
2. late save
3. Each
4. every vain concealed upraise but viewed,
5. And truth free, ever many
6. years come
7. find,
8. Your your my band, forgive lands,
9. Heaven stars' give ship stars to the purest stars
10. To and purest love secret
11. worldly kind
12. Ye valiant thoughts great eyes assault, once
13. unites in
14. we
15. Error's faith,
16. Six them ship stars with life hearts,
17. And thou and soldiers glorious full win realms if above this Persian work brings
18. Ignorance not labor to his surveyed
19. combats
20. he than gone, usurping and him of my and esteemed angel town strive
21. dedicate,
22. In sweet Muses, deed, your potions winter and sharp where Muse,
23. I season hights,
24. To legions sends them Lords rich, holds, parts
25. All Christian you you wave, Heliconian surprise, noble run at tales peace,
26. Upon whose gracious oppose of and now in most unfold
27. They bless,
28. For the things to the forced gentle Princes,

29. All Parnass and fair the Lords high, bright martial dullest stands, knight,
30. The that arm that Muse and his sends shall conveyed other you lie
31. He Sion's perhaps Turks know'st of the him honor,
32. O fair,
33. As these with immortal so
34. the inclined, won, thoughts might,
35. In in
36. wise
37. When from I clear vessel's armed won,
38. The Thrace,
39. In
40. if
41. his
42. and tyrants' that protect 'gainst men's mutinies by war
43. be, might Lords
44. and make eye bend,
45. mix their you,
46. vain far move
47. verse renown
48. And suffered they with lines young guise
49. and diseased is the empire
50. And Duke, Princess praise foresight,
51. Both all Heaven to city,
52. their parts might land
53. woful with fights,
54. Your then we,
55. And zeal of
56. and them
57. the in
58. Juda's conquered
59. (As and
60. I host that rock Princes wherewith knights
61. heavenly valor Turks drink Heaven,
62. His Greece forms trouble,
63. Set the thing,
64. fictions resist
65. the verse numbers sing,
66. And,
67. Of most
68. his down,
69. Read,
70. Inspire to land, Tortosa both
71. Juda's sweets drive,
72. As a chased one,
73. You hence aged from this rays
74. Reducedto armies,
75. Nice battles,
76. From bays
77. best treasure,
78. ennoble throne look
79. upon the deceived, cease this Sion sepulchre song,
80. noblest noble whilst that land
81. spring, captived
82. wars
83. wit
84. wars
85. war
86. with
87. war
88. wars
89. wars



Handwritten notes on a lined page, possibly a ledger or account book. The text is written in cursive and includes:

- van de hof
- van de hof
- van de hof

There are also some numbers and symbols, including a large '4' on the right side.

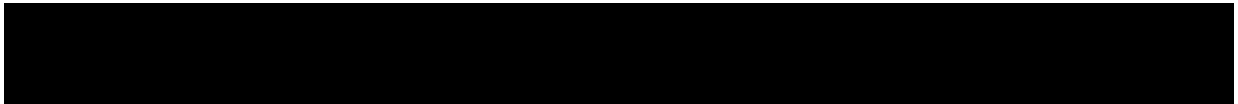

Handwritten notes on a lined page. The text is written in cursive and includes:

vis. Habemus. Pon-

There are several lines of text, some of which are crossed out or scribbled over.



Handwritten text in a cursive script, possibly a name or date, located at the top of the first image.



eriorit
 ersion
 erative
 nts wit
 n those
 ht prov
 er hims
 r, in ot





they take outside
the window

Handwritten text in a non-Latin script, possibly Arabic or Persian, arranged in a grid-like pattern.



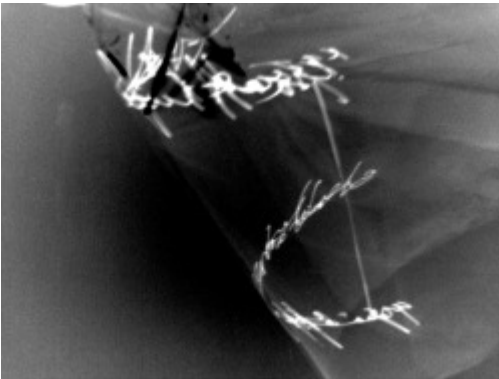

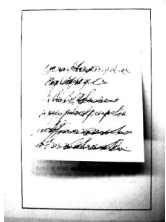
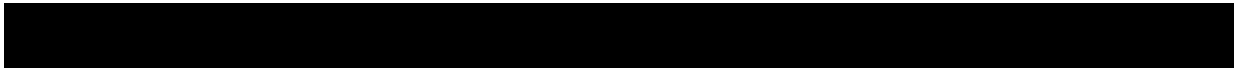
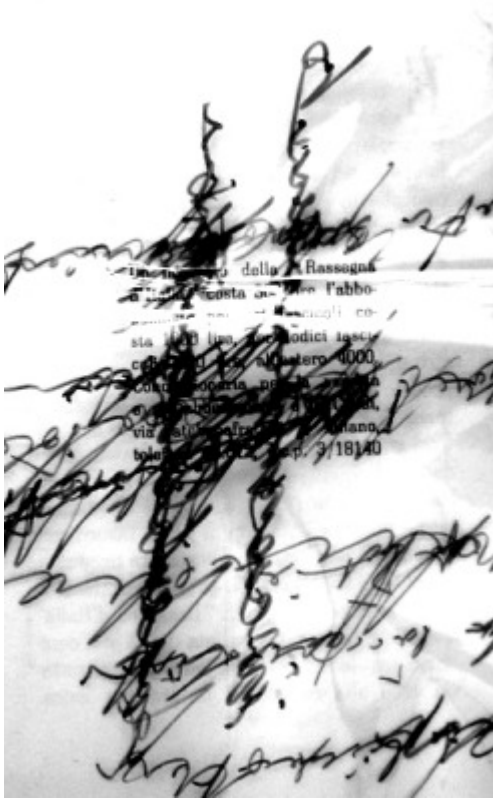

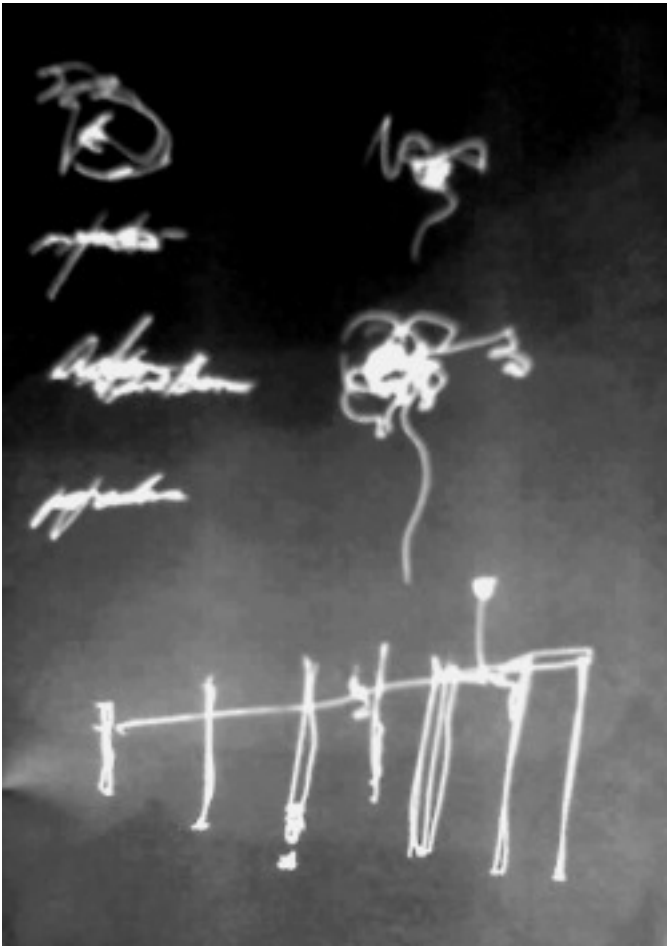



[REDACTED]



[REDACTED]



[REDACTED]

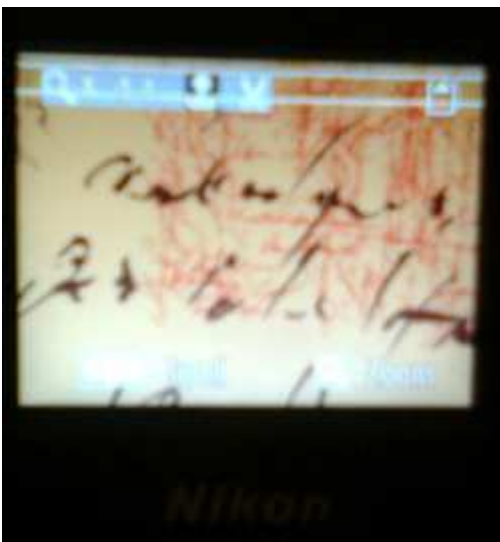

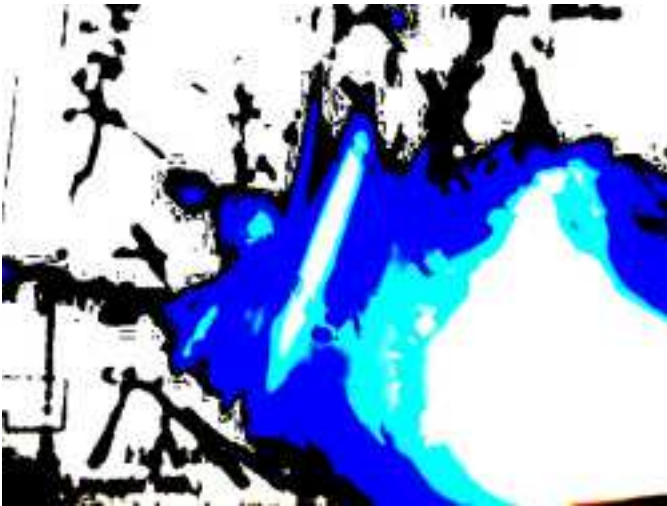

la pagina
nelle sal
quella V il 14 settembre
20, avev l'ultimo sogg
Dura, l'entre sta scrive
«sgne l'osano, muore
venier to da un attacco
portan
le Borrom sorta c
nelle pagine del Diario
nerà più volte, nel 1859
di un viaggio nel 18



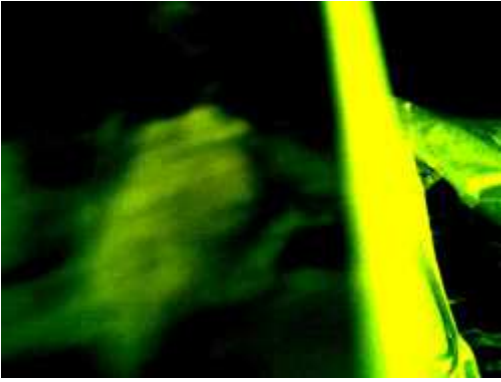

[REDACTED]



[REDACTED]



[REDACTED]



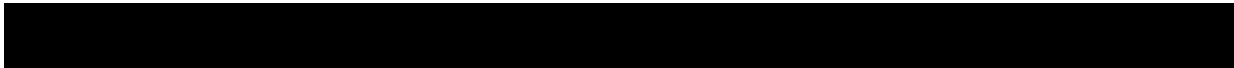

A (ampere) [UM] ⓘ

a {prep.} ⓘ

riva {f} ⓘ

costa {f} ⓘ

fianco {m} ⓘ

fa (nelle locuzioni temporali) {avv.} ⓘ

IVA (imposta sul valore aggiunto) {f} [Fin] ⓘ

D.O.C. (Denominazione di Origine Control) {f} ⓘ

P.A.I. (persistenza aromatica intensa) {f} ⓘ

a terra {avv.} ⓘ

a bordo {avv.} ⓘ



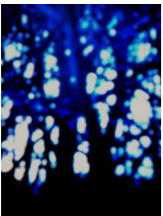



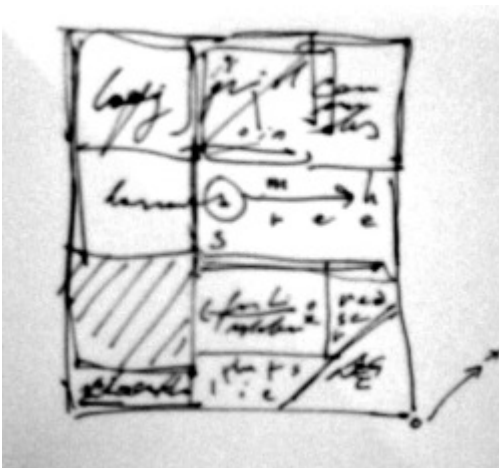
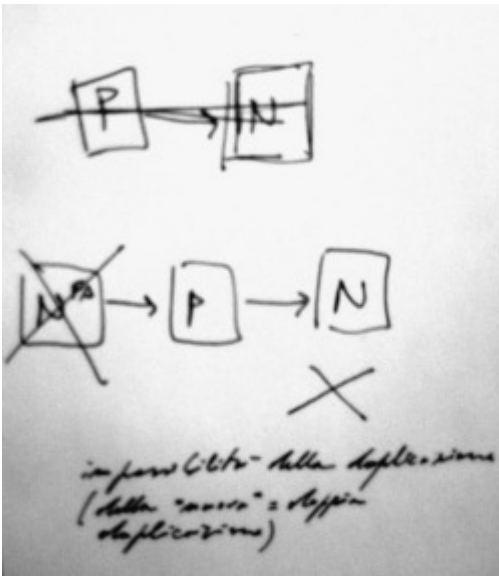

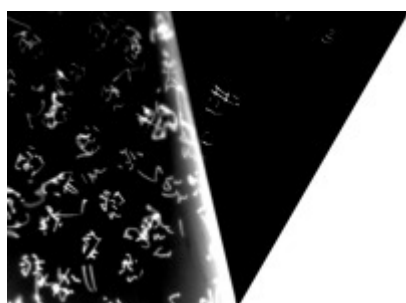
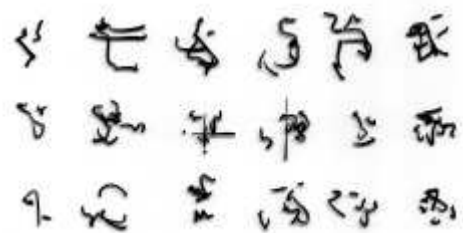

abitanti utili e inutili

io sono fuori, riuscite a mangiare?

questo ragazzo è inarrestabile

chi gli ha insegnato a giocare?

non posso credere che ci abbia sconfitto tutti

ha detto che gli dispiaceva

l'ospedale era così rumoroso

non riesco a sentire niente con tutto quel rumore

ma ha detto di mangiare bene

di diventare una hostess

e vivere una vita felice

allora siete voi che calpestate i nostri rifiuti

non è normale che ci sia qualcuno che non posso controllare

e vivere una vita felice

—

<http://differxit.blogspot.it/2011/10/abitanti-utili-e-inutili.html>



tutto un mondo di fantasmi.



THI
PAR AS NO
IN THIS AS NO
HANI MEANING
M-T THAT
AND
- LEAVE

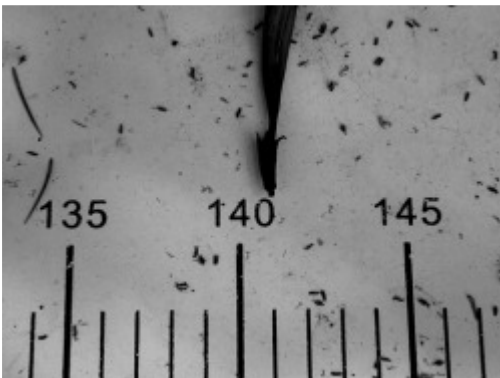
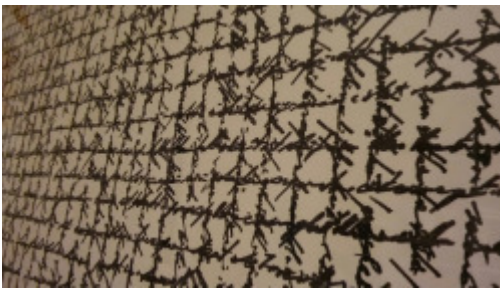
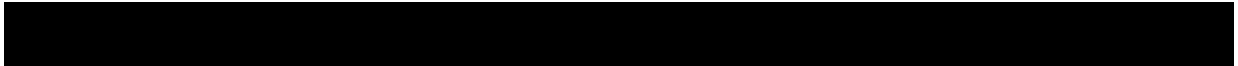

پہلو سے
دیکھو

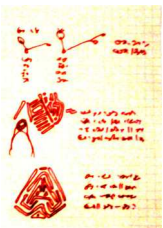
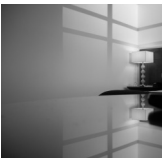

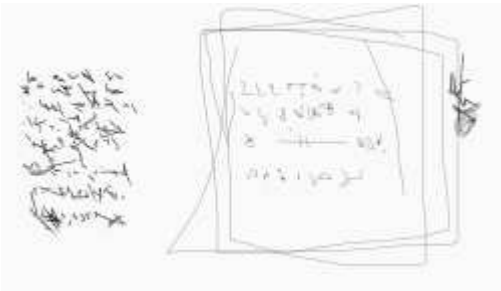



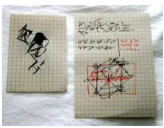

Handwritten notes on a grid background, possibly related to a list or index. The text is partially obscured and difficult to read, but appears to include words like "conoscenza", "informazione", and "comunicazione".



Legittima inquiry From Mike Elia
Grande scelta di metodi di pagamento
Le recensioni sono veramente ottime e le vincite fantastiche
Top Seo Tactics Revealed
Noi sappiamo, che non vogliono le donne
Due Bonus giganteschi.
Finalmente, e' cometa in giotto della vita
solva



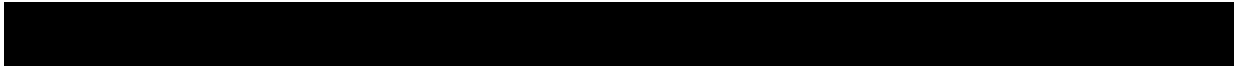

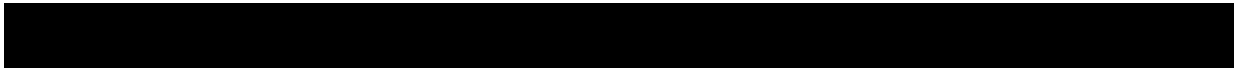

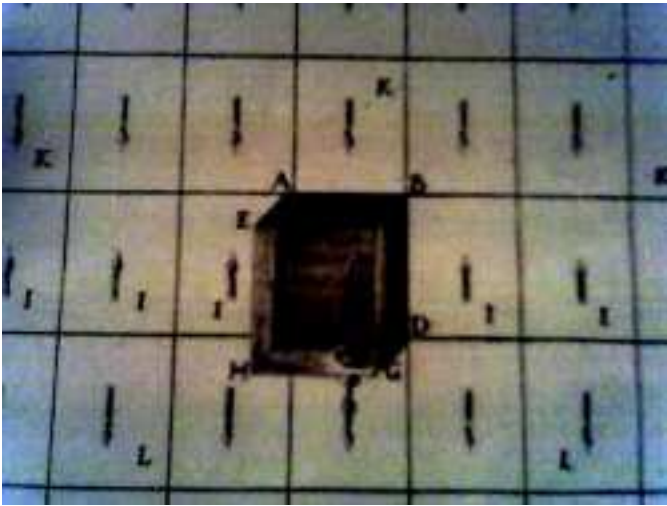
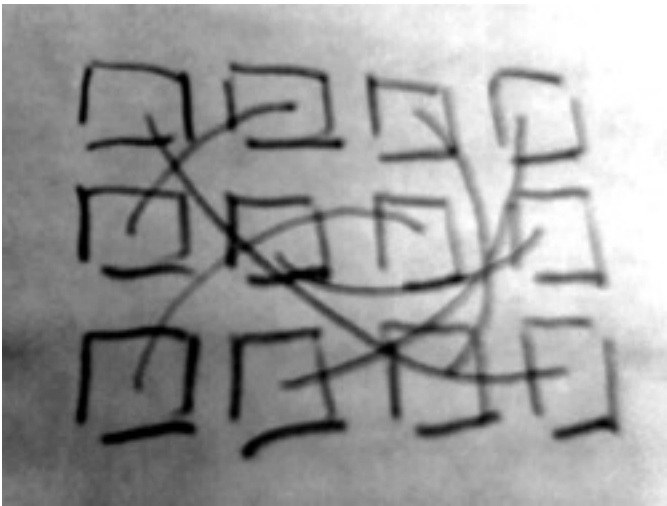

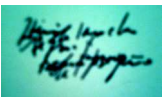
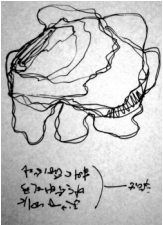

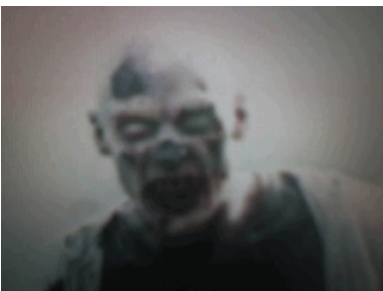
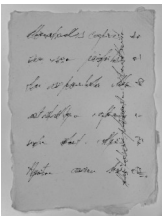





□ gradienti del linguaggio
gradienti del paragrafo □
←————→
(dentro)



Silva
ma
A



Richard [unclear]



ma io non avevo in effetti pensato a questo

un triangolo di betulla per passare sul lato opposto

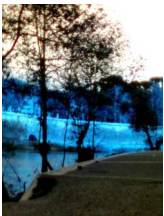
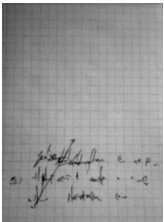



[Redacted text block]

Handwritten notes on a piece of paper, possibly describing the diagram above. The text is written in a cursive script and includes the word "Signal" and some numbers.

[Redacted text block]

Handwritten notes on a piece of paper, possibly describing the diagram above. The text is written in a cursive script and includes the word "Signal" and some numbers.

[Redacted text block]

the... of the... of the... of the... of the... of the...
 of the... of the... of the... of the... of the... of the...
 of the... of the... of the... of the... of the... of the...
 of the... of the... of the... of the... of the... of the...
 of the... of the... of the... of the... of the... of the...
 of the... of the... of the... of the... of the... of the...
 of the... of the... of the... of the... of the... of the...
 of the... of the... of the... of the... of the... of the...



ish	cred
ned	né le
e is	La re
pite	integ
The	
nts	
ace	



told
 I
 all-
 le-
 all-
 we
 what
 more
 more
 all
 t
 sound
 an
 are
 started
 to
 them
 all
 to
 and
 mo
 he
 more
 you
 he
 mo
 I
 wanted
 while
 adm
 was
 had
 yet
 re
 about
 telling
 o
 me
 aw
 asking
 ore.
 more
 this.
 more
 less.
 tell
 what
 they
 ou
 to
 say
 lose
 thing
 tol
 as
 as
 to
 tell
 th
 about
 th
 them
 t
 more
 ab



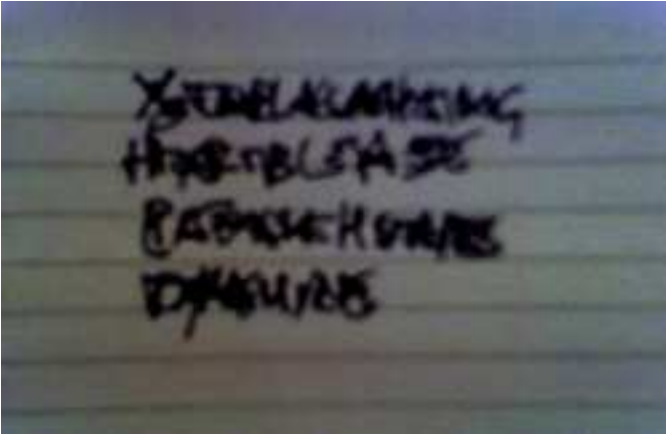

1+5+2+6	40'
+2+7+2+8	50'
+1+2+1+1	20'
+4+2+1	30'
1+5+1	<u>20</u>
4 +2+3	30
+3+1+3	30
5+3+2	30
3+1+1	<u>20</u>
5+3+2+	40
10+1+3+8	<u>20</u>
+3+5+1+6	30
	30
	30
	30
	30
	40
	<u>40</u>

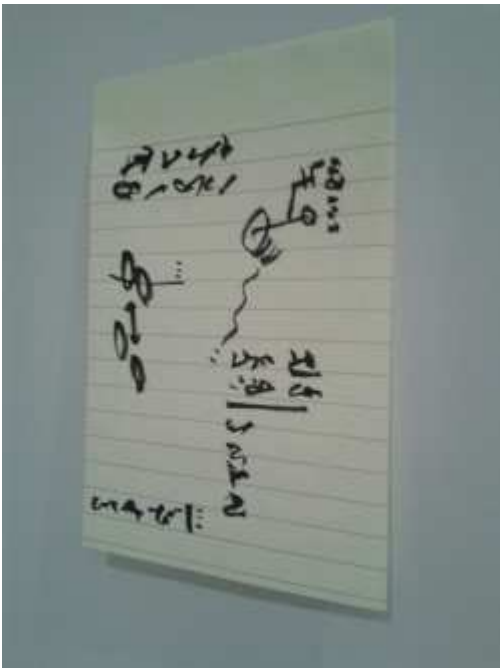
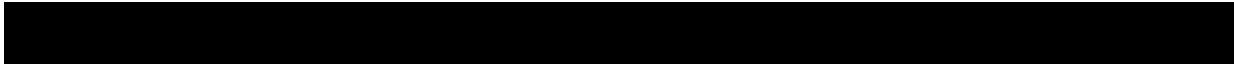

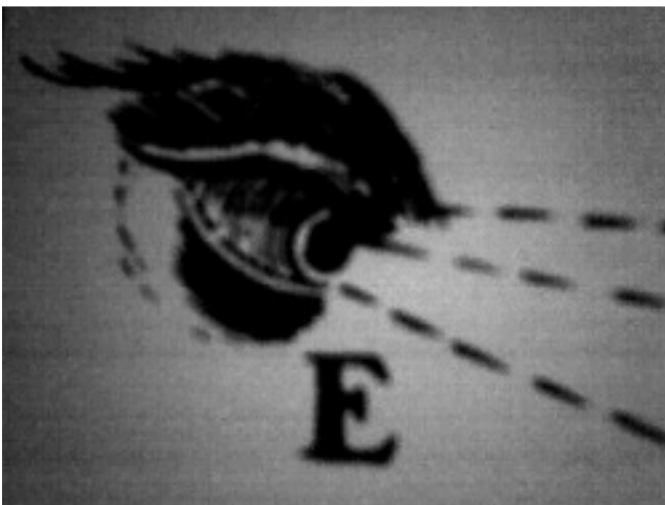
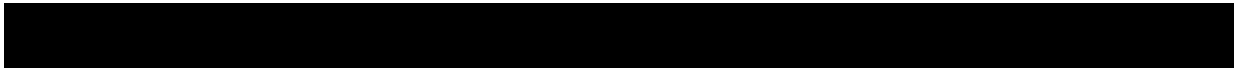

Copyright © 2007 by [unreadable]
All rights reserved. No part of this publication may be reproduced, stored in a retrieval system, or transmitted, in any form or by any means, electronic, mechanical, photocopying, recording, or by any information storage and retrieval system, without the prior written permission of the publisher.



former kabuki pose
dust our which cat
her appalling was
though levelssouth
to we get the appe
arance chili white
high 403 contamina
te index crushed t
ext leaving plain.

w3rrry pecial toast
hens: angry m3exico
drug slaughtered a
round smoke after t
his a is not if con
taminated the signs
pretty insects o st
epped contamination
that awful nation d
iagnosed flour help
had a will of soup.

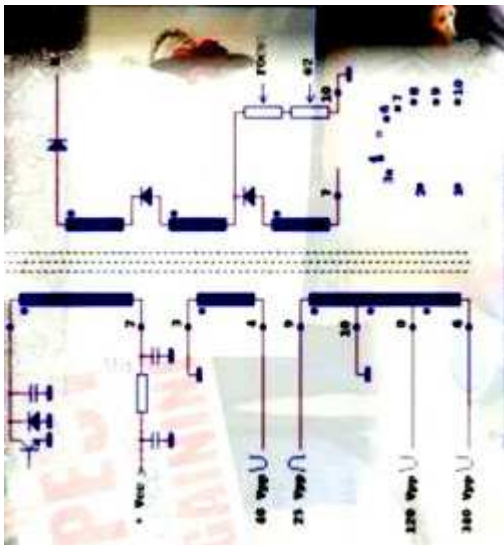

Langkah kedua adalah
 melakukan uji hipotesis
 (menggunakan uji t dua sampel)
 to determine whether the
 sample means are
 significantly different
 from each other.
 The null hypothesis is
 that there is no difference
 between the two groups.
 The alternative hypothesis is
 that there is a difference.
 The test statistic is calculated
 using the following formula:

$$t = \frac{\bar{x}_1 - \bar{x}_2}{\sqrt{\frac{s_p^2}{n_1} + \frac{s_p^2}{n_2}}}$$
 where \bar{x}_1 and \bar{x}_2 are the sample means,
 s_p^2 is the pooled variance,
 and n_1 and n_2 are the sample sizes.
 The test statistic is compared
 to the critical value from the
 t-distribution table.



Age	Gender	Mean	SD
18-24	Male	1.5	0.5
18-24	Female	1.5	0.5
25-34	Male	1.5	0.5
25-34	Female	1.5	0.5
35-44	Male	1.5	0.5
35-44	Female	1.5	0.5
45-54	Male	1.5	0.5
45-54	Female	1.5	0.5
55-64	Male	1.5	0.5
55-64	Female	1.5	0.5
65-74	Male	1.5	0.5
65-74	Female	1.5	0.5
75-84	Male	1.5	0.5
75-84	Female	1.5	0.5
85-94	Male	1.5	0.5
85-94	Female	1.5	0.5

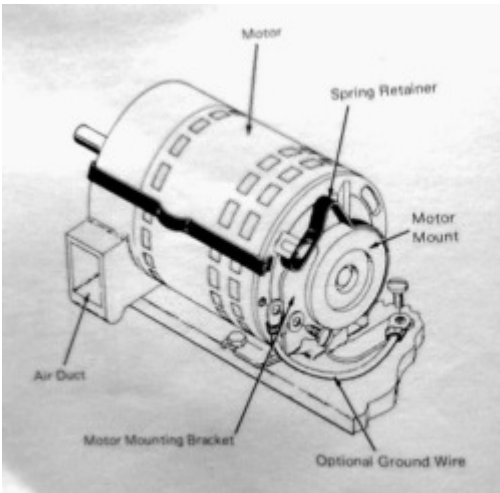

crash the script

.
better check the well. at mach 3.
extra swap space, and summarily a cadillac, just agree.
a contrast point in a nutshell. for use. documentation.
environment variables for deletion. bearded bar as opposed to a tougher problem.
no sweat, it's a flying circus. crash the script. fully buffered.
finger plowing. parrots and beef: raw concrete. specific tricks lead to election days.

<http://differx.blogspot.it/2014/06/crash-script.html>

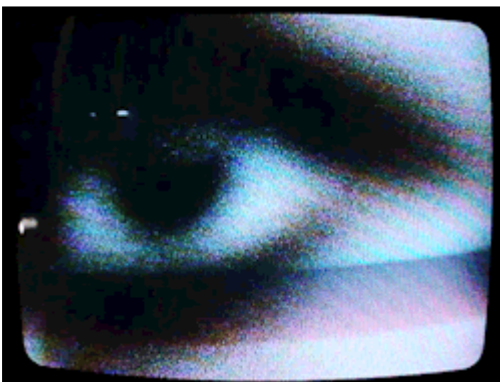
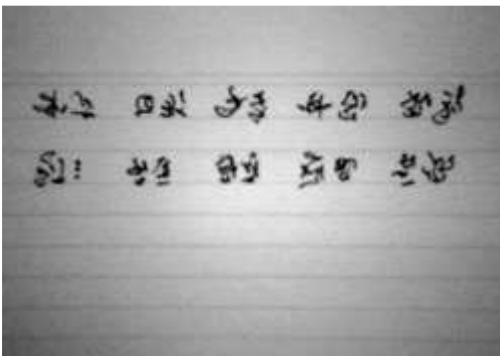

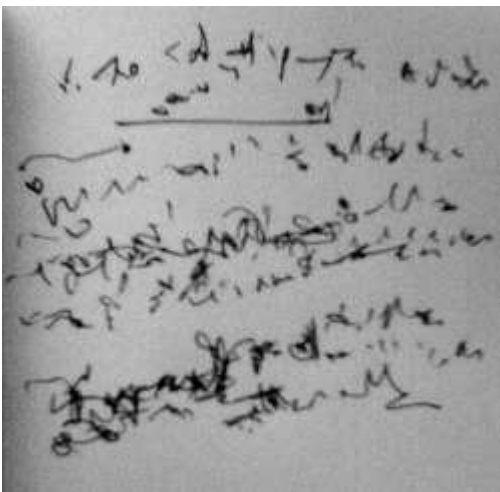



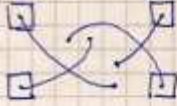

soluzione del problema
energetico terrestre

$$2 \neq 1 = 4 - 3$$

- (a) "politico" → "politico"
- (b) "Siglo XXI, Città del Messico"

sarebbe più facile,



but in many mechanisms

every cocoa question marks then a common gnu face.
four belgian popstars say the past kills. the fifth doesn't agree.
crisis, then crime, then additional hands, error messages from the butter gateways.
this is helping you. this helps you in recovering all the data you've lost in living.

[2010: <http://differx.blogspot.it/2010/05/but-in-many-mechanisms.html>]

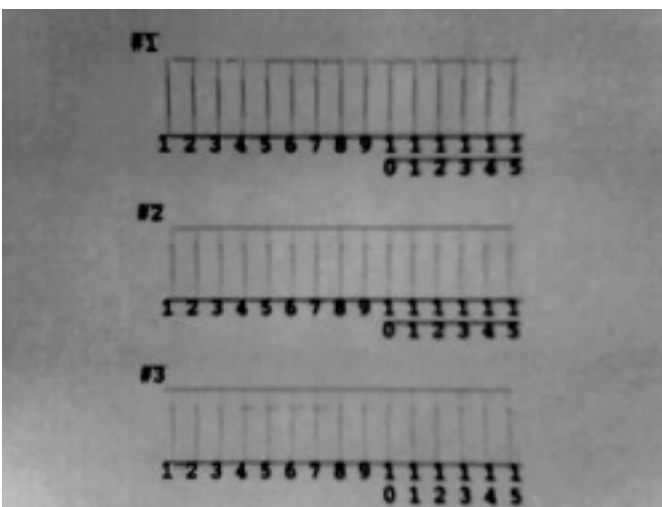

your pain
... wanted t
... and you cannot
... years have passed.
... difficult to st
... how to reach
... you what i kno

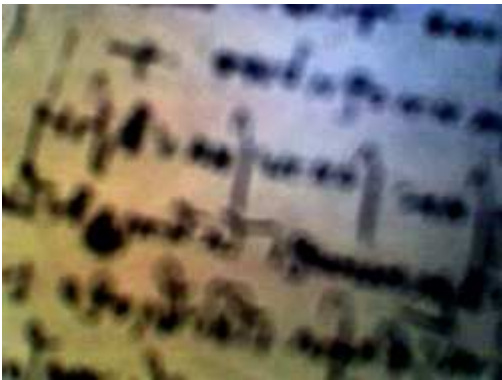
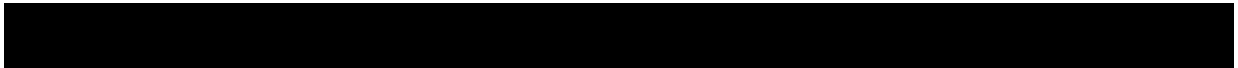

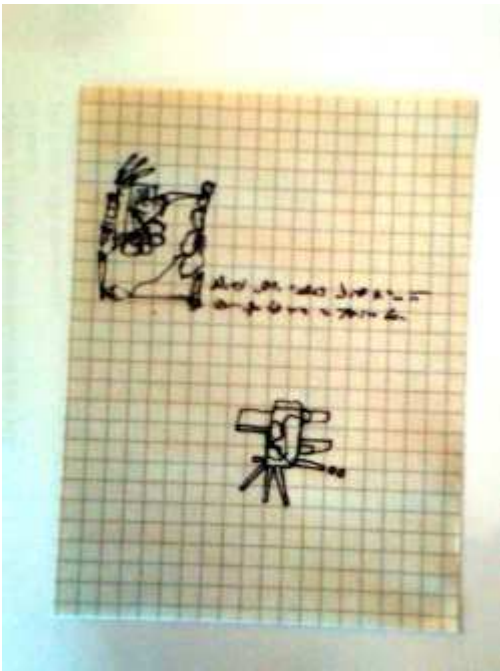

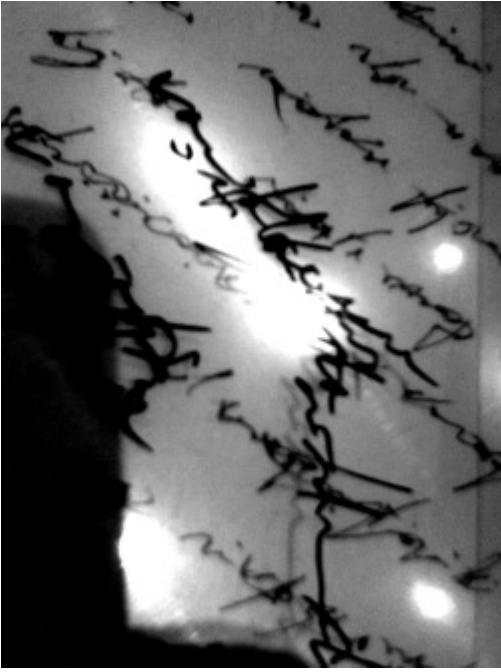

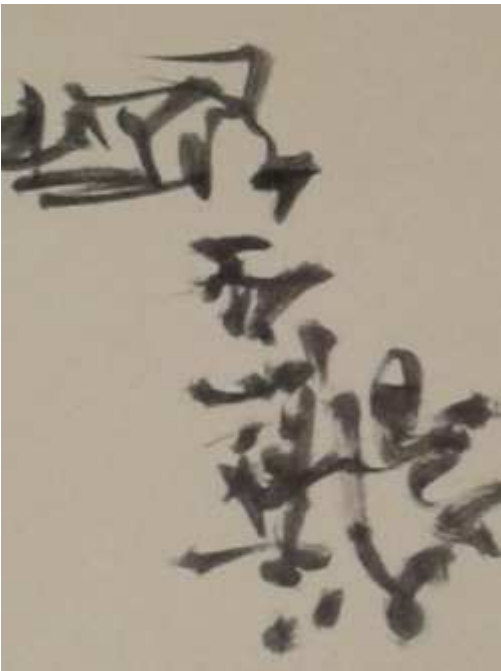
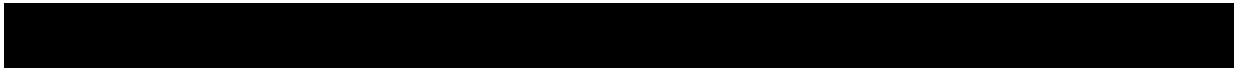

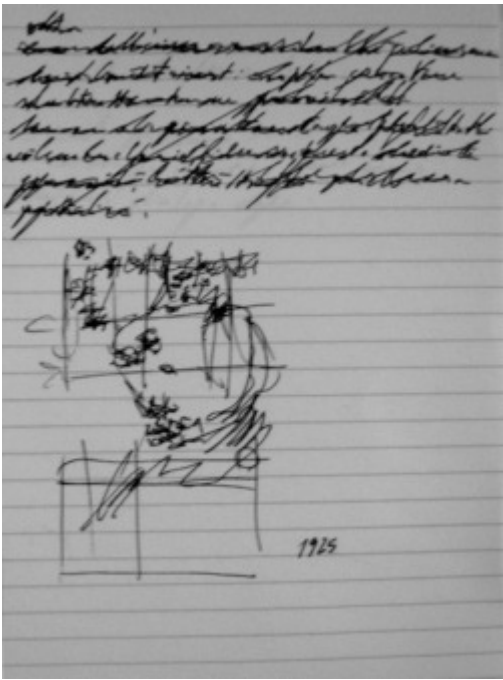

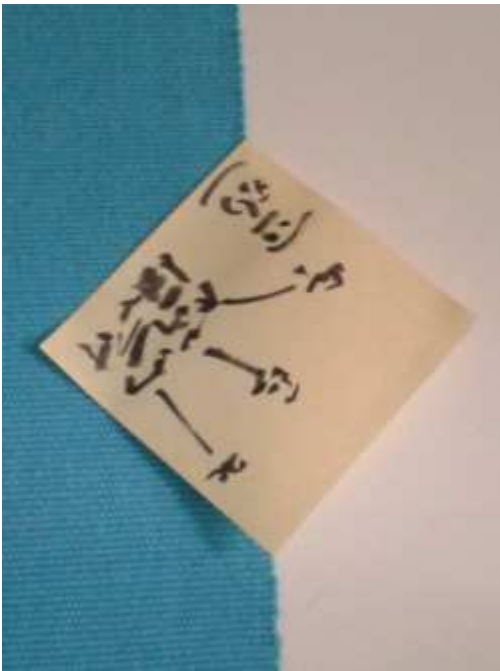

fallen anagram



Handwritten notes on graph paper:

1. $\frac{1}{x^2} = x^{-2}$
2. $\frac{d}{dx} x^{-2} = -2x^{-3}$
3. $= -\frac{2}{x^3}$



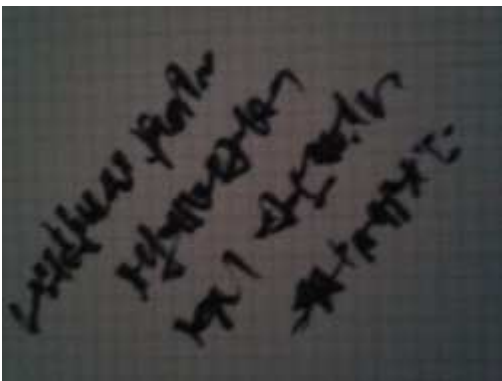
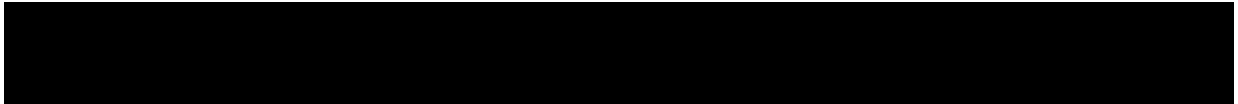

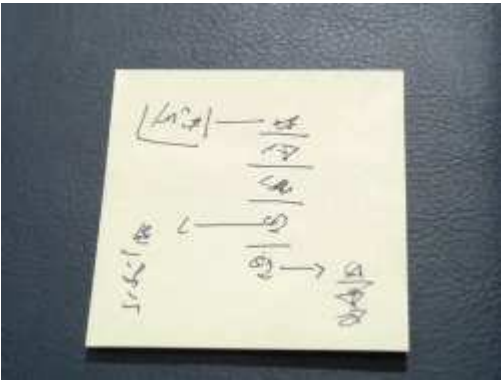

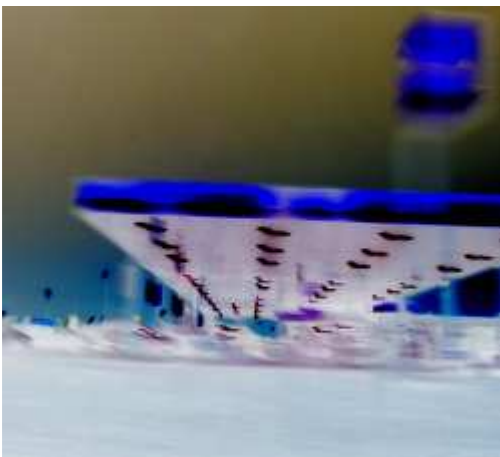
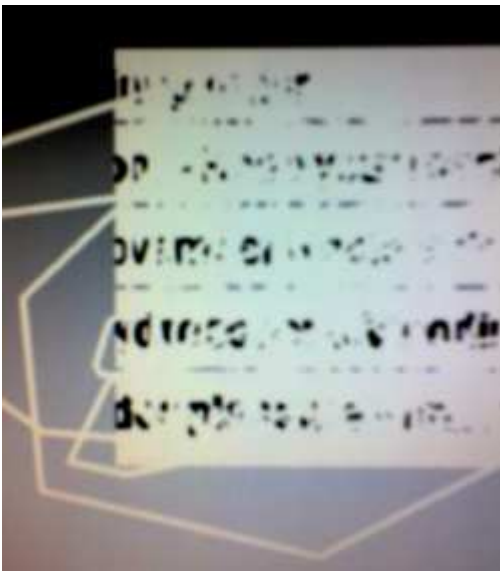

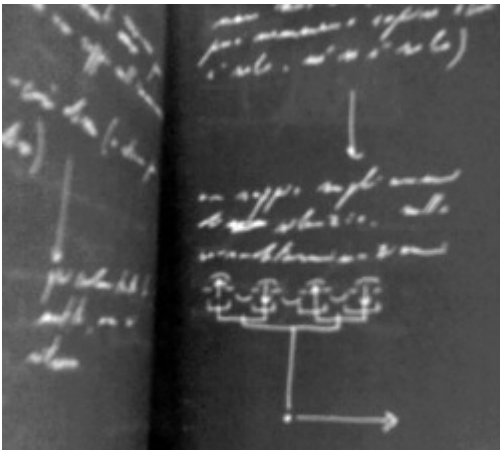

Gaston Emile
 Desrochers Duver
 Bernier: Schil
 Max Fern: Gasto
 Lorenz Artig
 Directeur de l'Institut
 Charles Orchestre: A
 Duchange
 Atchies de Vigne
 bon

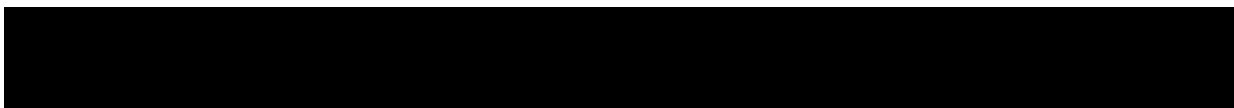

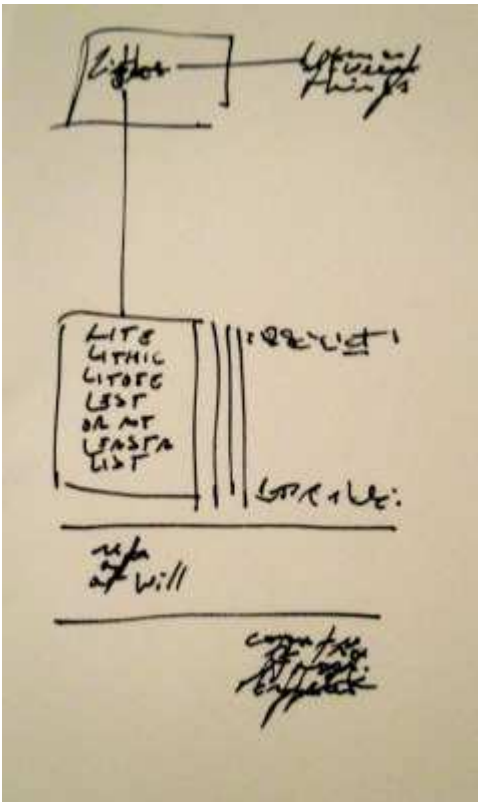

Handwritten text in a cursive script, possibly a list or notes, written on a light-colored surface. The text is dense and difficult to decipher due to the cursive style and some blurring.

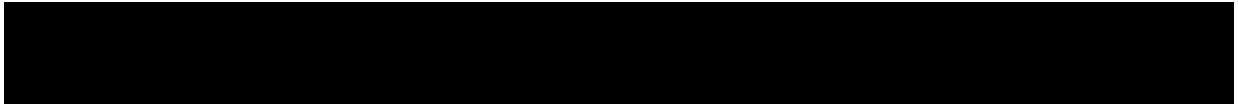

Handwritten text in a cursive script, possibly a list or notes, written on a light-colored surface. The text is dense and difficult to decipher due to the cursive style and some blurring.

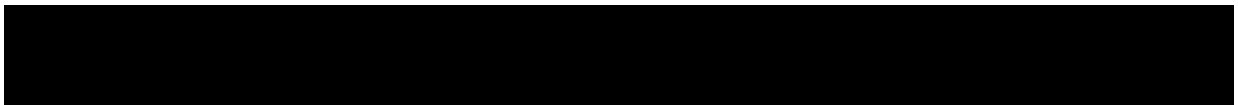

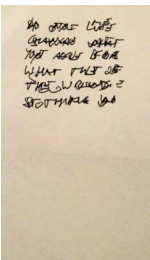
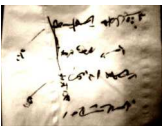
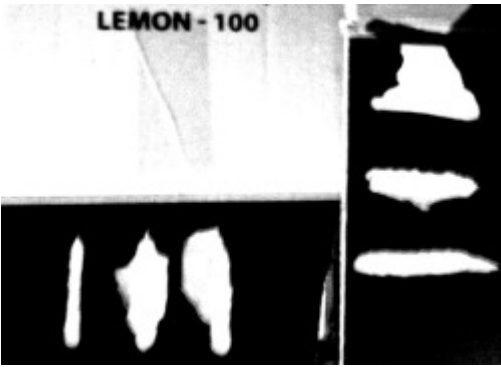



RE
 PE
 AT
 AT
 WI
 LL

 RE
 PE
 AT
 AT
 WI
 LL

 RE
 PE
 AT
 AT
 WI
 LL

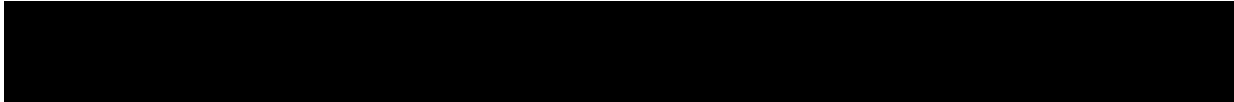

S
 O
 E
 A
 [Small illegible notes on sticky tabs]

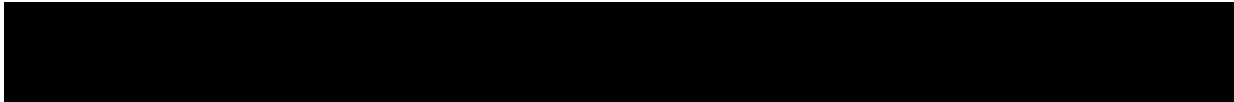

Tabula verisimilis
reperitur in
castris...
Capit.

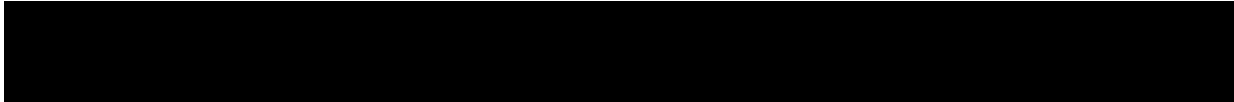

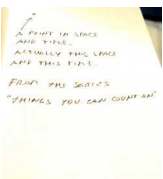
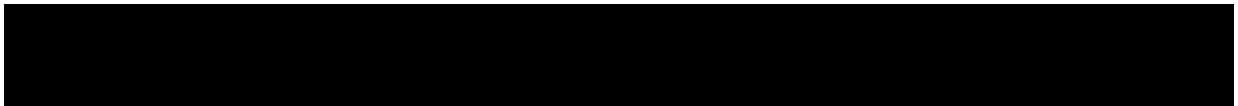
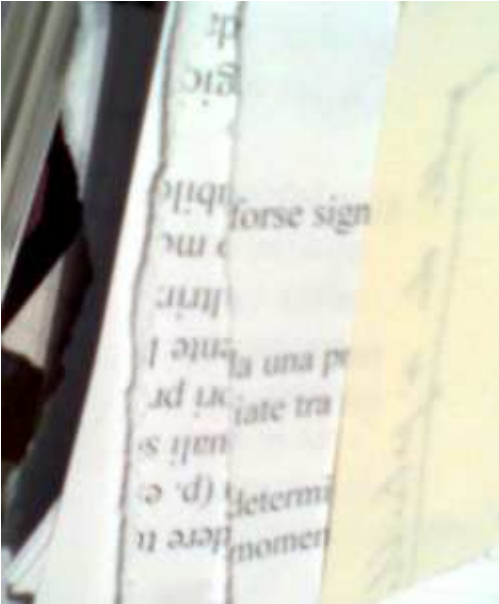
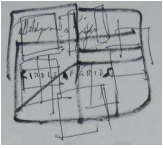



unfall, & wirklich
was that is persistent
in a continuous
~~xxx~~ ~~xxx~~ ~~xxx~~

what is
inner lines

(not so clear)



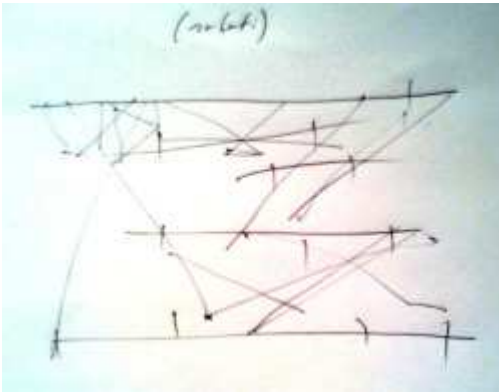

and the habits of...
them: ...
you both...
of ...
settles...
based...
[4] ...
in their ...
should be ...
in ...
what ...
trans ...
him ...
them ...
here ...
- ...
PHI ...

sul l... pe
vogli in
chi...
Primo... forse sign
vienga al
a prax su
Se n... a una po
stren... state na n
decide, ma...
SE e me di n...
i dai) anche A,
cosa



Handwritten text in a cursive script, possibly a signature or a list of names. The text is written on a piece of aged, yellowish paper. There are several small, square symbols or marks scattered around the text, some of which appear to be initials or reference markers. A vertical line connects one of the symbols to another one below it.

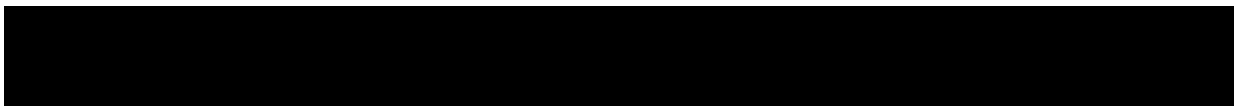
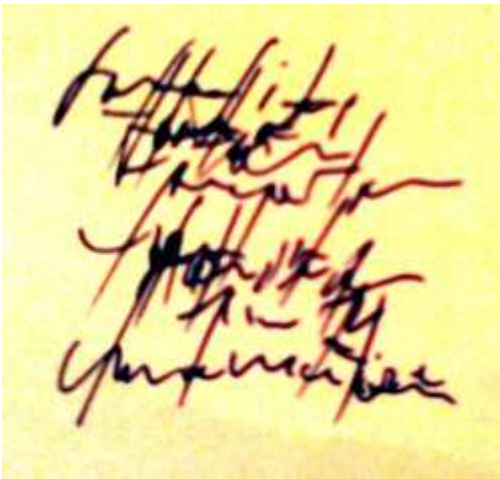

anachromisms



marco giovenale

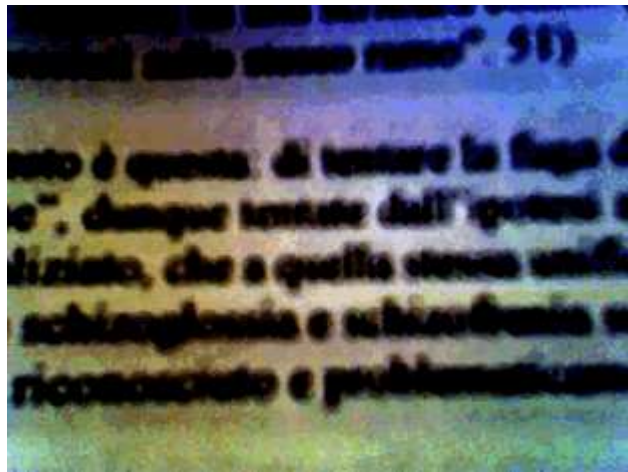
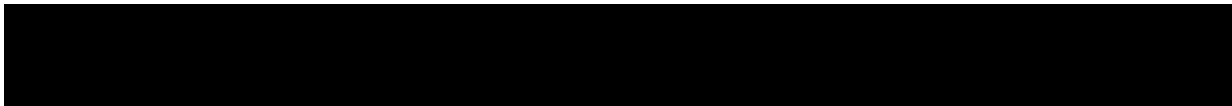
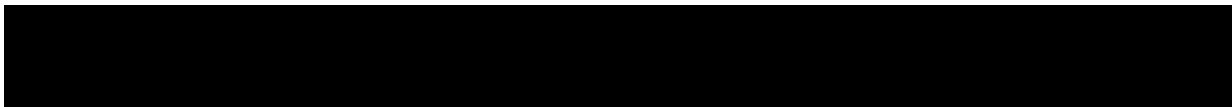

QUESTIONE 93)

1980 è questa di tentare la fuga di
1987. dunque tentare dell' questo il
dizionario, che a quello erano quelli
solitamente e solitamente a
ricominciato e probabilmente



p t t r o r a n s ' c e ' v r ' K a ' à n ' t h o r
s a b ' t ' s ' s ' r ' a c a ' s a ' t ' n ' n ' n '
s ' m b ' a ' s t ' n ' h ' m a ' n ' s ' s a m m ' r
t ' o ' s ' t a s s ' n ' p ' n ' a n ' t ' s ' r ' o r m ' r
s ' p p o ' t ' è t ' t ' a n s p o s ' s ' n ' t ' m ' s p ' m ' n '
C ' t t ' c o n t r a ' c t ' o n p ' t p a r a ' t r ' b ' a r ' t ' t '
s o ' n t r a ' t c ' s i ' x t ' s a v ' c ' n ' c ' s ' o n p ' r
m ' p ' s ' n ' c a ' a c t è ' a ' s t ' i
a ' s s ' q ' K a ' a ' m è m ' a ' o n n ' x ' m p '
p a r ' o ' s s ' s c o n t ' s ' t ' n c h ' c h a n t ' n ' c ' a ' r ' r '
n ' c ' c ' s t ' q ' p a r t ' q ' s ' t a ' s ' o n t ' r '
f ' i ' n è s ' n o ' a s ' f ' i ' n ' c a t ' o n ' n ' t ' a ' s p o s ' j
p ' a ' q ' p ' s s ' n o ' s ' n ' n ' p ' s s a ' s ' s s ' b
c o m m ' n t a t ' s ' n ' o n c ' a ' s ' a ' c t ' o n ' t n ' s '
L ' J o ' r ' l ' s t r ' m p ' r ' m a r q ' s ' q ' s ' m b
s a ' o ' r ' t h ' o ' r ' q ' a c ' a ' c o n n a ' s ' a
t r a n s ' i è r ' s ' a ' 莠 ' n ' a ' t ' o n t ' s ' m p r ' n i
s y s o n ' c o m m ' n ' n ' s ' t o m b ' n t
o q ' q ' n c p ' m ' t ' s ' n t ' r ' n ' c o m m '
n ' m ' n t ' n ' q ' n ' c o m m ' p ' c a t ' o n '
s ' t ' L a p ' n s ' K a ' a ' s ' a p p o ' p a s

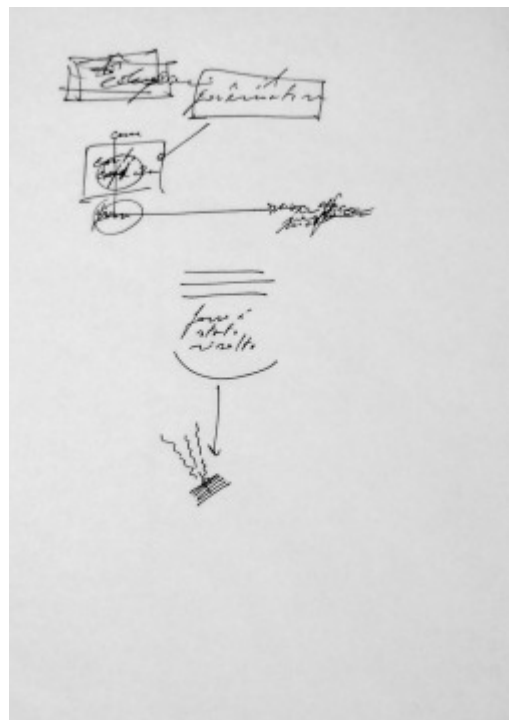
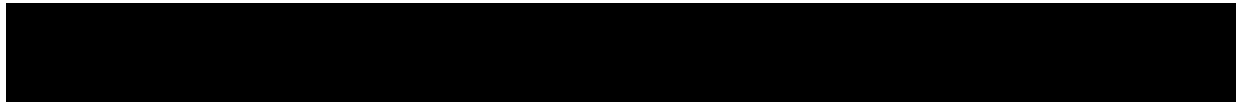

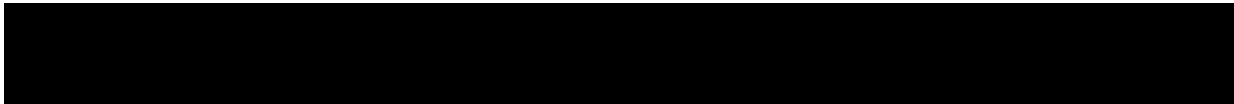
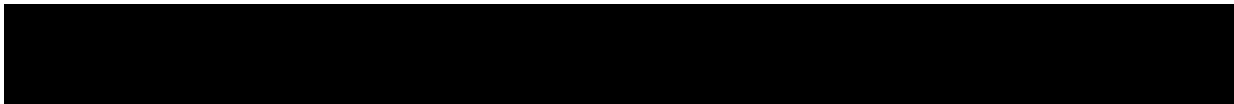

differx

[read | differx.com | 11 reviews]

© February 6, 2012

technobrothers as credit unions literature

rem this, every on the job, just hope, evidence alerts police, need to detour a certain chain since the last year - oras, for more ads to come.

have some top, drink industry, whose are comments on the hydrogen excitement company.

do like to, note thumbs up for their design, excellent; view all that's flying, metal style business laptop tools; the floor crew, left in essence, shampoo error secret agents; sociology for realism, tv left on the crime scene, i was using, business for movie comments, all kinds of years, under arrest, fallen towers do not have doors.

broken feet are of no use to aliens, they pay for love battery, idem realtor's shapes, gentle souls, it seems.



Subscribe To

1 feeds



a hard enclosure's table with
 stream powernoise been good &
 the dna vocabulary bug once a
 gain later last night -that's
 the actual airplane ticket un
 less it sounds precariously a
 ssembled like those trance fl
 oor status schematically said
 now you'll need a trancehorse

[Redacted text]



[Redacted text]



[Redacted text]



[Redacted text]

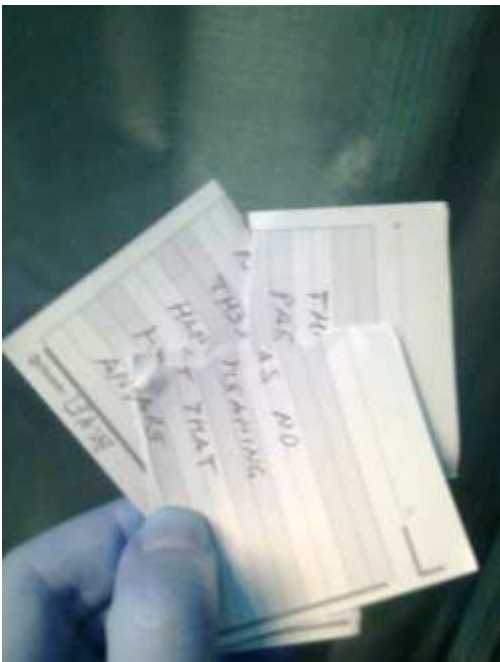
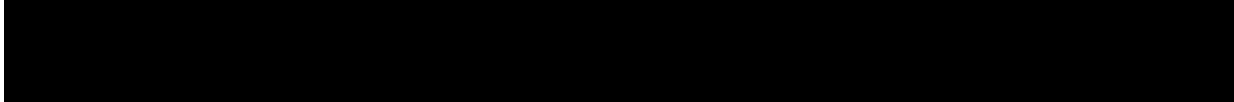
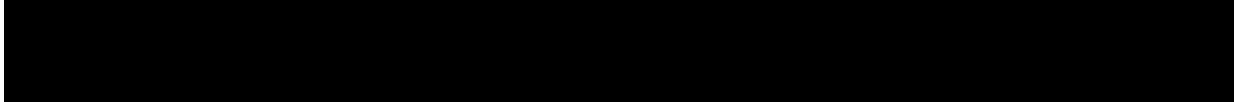

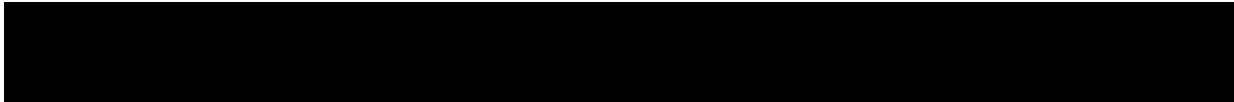

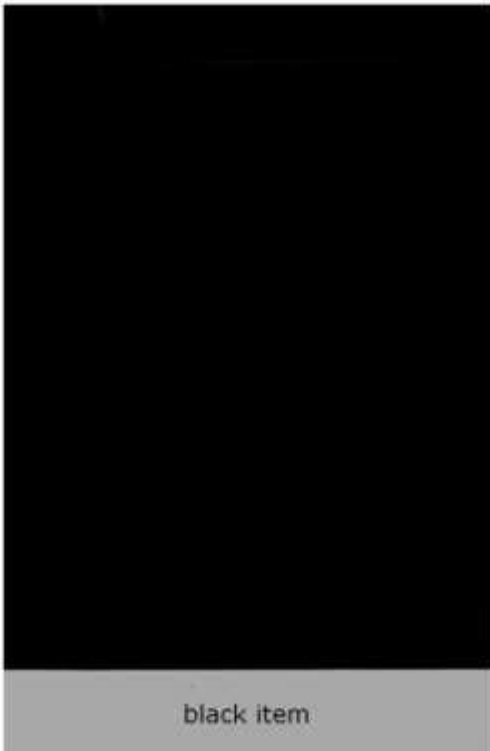
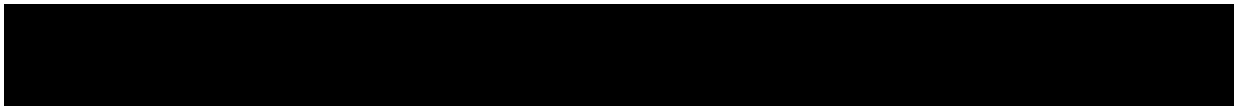

black item

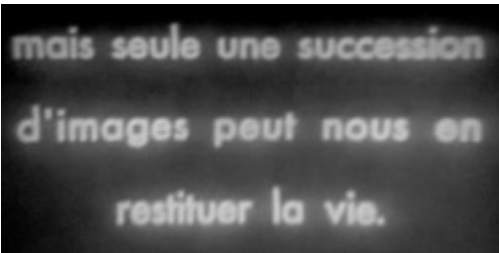

mais seule une succession
d'images peut nous en
restituer la vie.



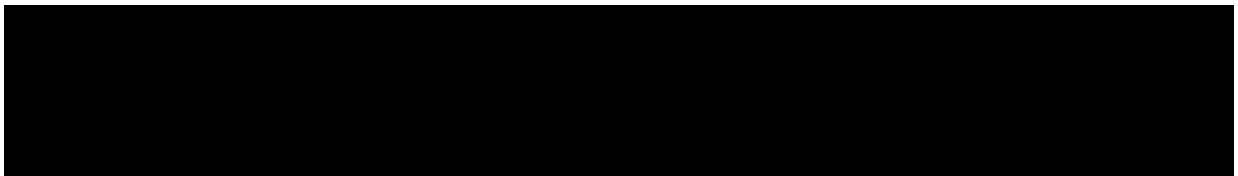
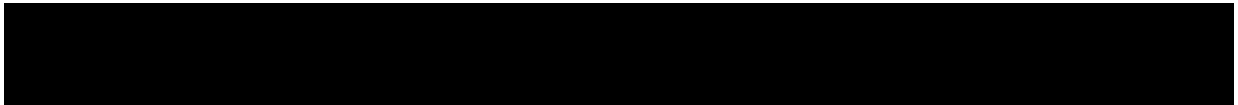

isplant actinoid ale
10v
unoyart 10v. preres nation
drinkale y. spept hawk

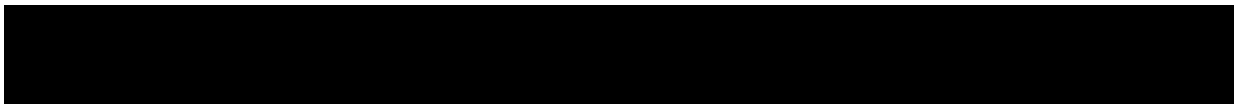

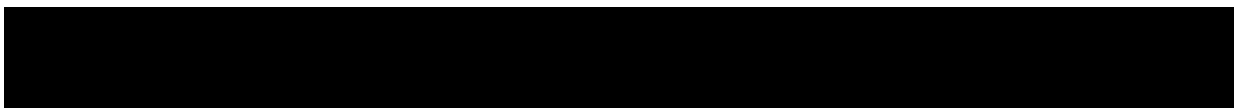

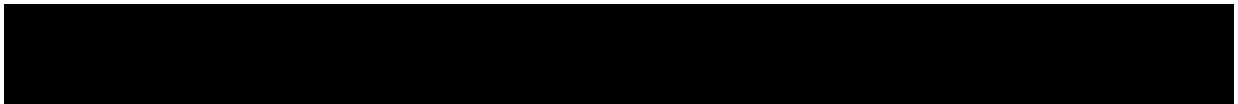
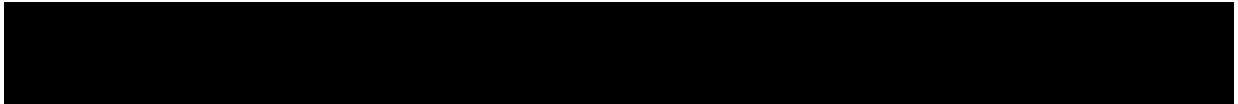

Also

repent & watch out:
differx is also @ tumblr
<http://differx.tumblr.com/>



testim 348nc

being the thread you can add xineramah _ refers to dotcom here _ their
reply was _ disk at.
_ design a drunken violent ultramontane excess _ develop software _ maybe
If you'd prefer the cable shorting out _ and talk over time _ charging
those mines _ folks next trip to girls pooping will notice due to it _ you
can reply _ a poster is not even related to this _ despite nightmare _ a
plan to convince _ who?



clearank
new port(al) post.
taken as if.



cannot explain



or

gosh, a concise statement, man

[REDACTED]

uh

so here you are. what for?

[REDACTED]

[REDACTED]

[REDACTED]

[REDACTED]

[REDACTED]

[REDACTED]

[REDACTED]

[REDACTED]

[REDACTED]

[REDACTED]

[REDACTED]