



INSTALLATION INSTRUCTIONS

Thermally Broken Framing and Door Installation

SL-450TB (2" x 4-1/2" with 1" Glazing) & SL-600TB (2" x 6" with 1" Glazing)



IMPORTANT: Read all instructions before beginning installation.

Special-Lite provides these instructions to help prevent installation problems caused by most common errors. They are not intended to be foolproof and suitable for every situation. There are many variations of installations not covered in these instructions that Special-Lite assumes are general construction knowledge to an experienced installer. Selection of an experienced installer is the sole responsibility of the project owner or responsible party. Failure to follow good practice in installation will void the warranty on Special-Lite products.

If you have any questions about installation techniques for your particular project, please call 1-800-821-6531 and ask for a Special-Lite Customer Service Representative or Field Service Technician.

You can find these and other Installation Instructions at special-lite.com.

Thermally Broken Framing and Door Installation

SL-450TB (2" x 4-1/2" with 1" Glazing) & SL-600TB (2" x 6" with 1" Glazing)

Notes

- Be sure to check all shop drawing, installation instructions and glazing instructions to become familiar with the project.
- Check all materials upon arrival and be sure you have everything required to begin the installation.
- All work should start from a benchmark, and/or column center lines, as established by the architectural drawings and the general contractor.
- All materials are to be installed plumb, level and true.
- Protect all anodized materials during and after construction. Cement, plaster, alkaline solutions and acid based materials can be harmful to the finish. Masonry runoff may leach harmful acids onto the anodized materials. This situation must be taken into consideration as soon as the materials arrive on the project.
- Clean aluminum surfaces with a mild detergent and water. Never use any kind of abrasive agent.
- The shear block fabrication and erection method permits the preassembly of frame units to be assembled in the factory and on the job site. These frame units are joined with shear blocks and installed as an assembled unit into the opening on top of the sill flashing being used.
- It is important to mark all parts and pieces that are removed from the framing when unpacking. Snap stops are shrink wrapped to their proper locations and should be marked to make sure they are reinstalled in the same position.
- Check work orders or prints for proper inside or outside glazing. Verify that all frame components are oriented in the same direction. The Special-Lite standard is to glaze from the exterior side of frame.
- Measure the new frame and door(s) to make sure everything is sized and located correctly. This is especially important in retrofit cases before the demolition of an old opening.
- Immediate door framing (lock jamb, hinge jamb, and header) is .125" wall thickness.

Perimeter Door Frame Installation

1. First, mark the position of the door stop on the door jamb and remove the door stop. Frame mounting fasteners are to be mounted in door jamb beneath door stops. Door stops will be reapplied after frame installation.

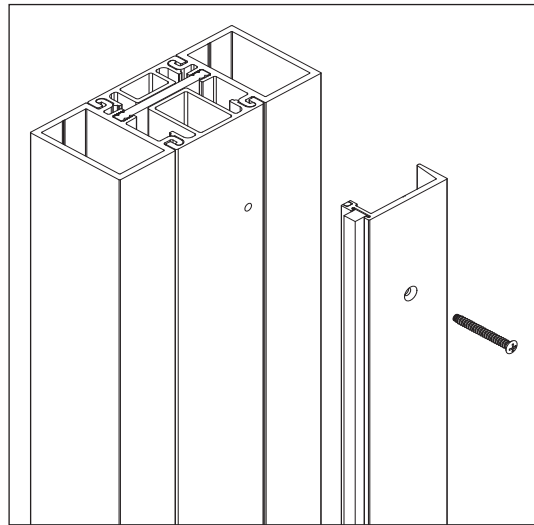

2. Mark mounting hole locations approximately 4" from both ends of vertical tubes. Then mark additional mounting locations on the frame. Space mounting holes no more than 24" apart.

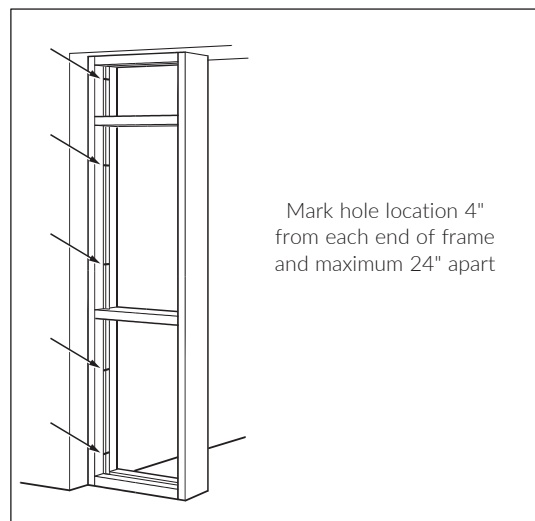

3. Mark mounting hole locations in header. A minimum of (2) mounting fasteners are required per header, with additional fasteners spaced no more than 24" apart. Be sure to place a header mounting fastener as close as possible to each vertical frame member.

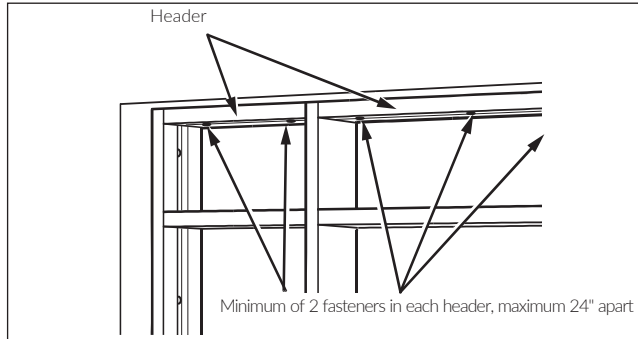

4. Drill an access hole under the doorstop at all mounting hole locations marked on frame. Drill a mounting hole (1/16" to 1/8" larger than the screw diameter) through the back side of the thermal break. Mounting fasteners should mount on the thermal break and not the pocket filler.

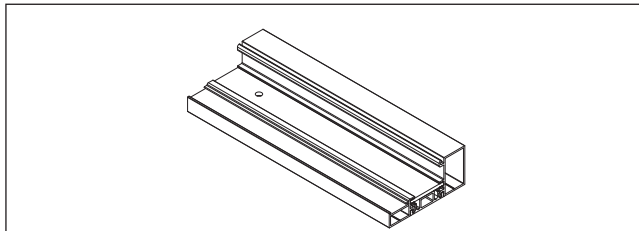

Door Frame and Side Lite Assembly and Installation

Note: During assembly, caulk frame components carefully at all joints. Sub-assemblies assembled at the factory have been caulked. *Be sure to use caulk of same color as framing. Do not use clear caulk.*

Assemble and Caulk the Frame Unit

5. Install loose horizontal frame pieces to vertical subassemblies. Shear blocks on verticals are installed at the factory.
6. Remove factory-installed screws in shear blocks. Apply caulk around shear blocks so that attaching horizontal frame members will be caulked entirely around mating surfaces.

7. Slide horizontal frame members onto the shear blocks and install the shear block screws. Wipe off excess caulk.

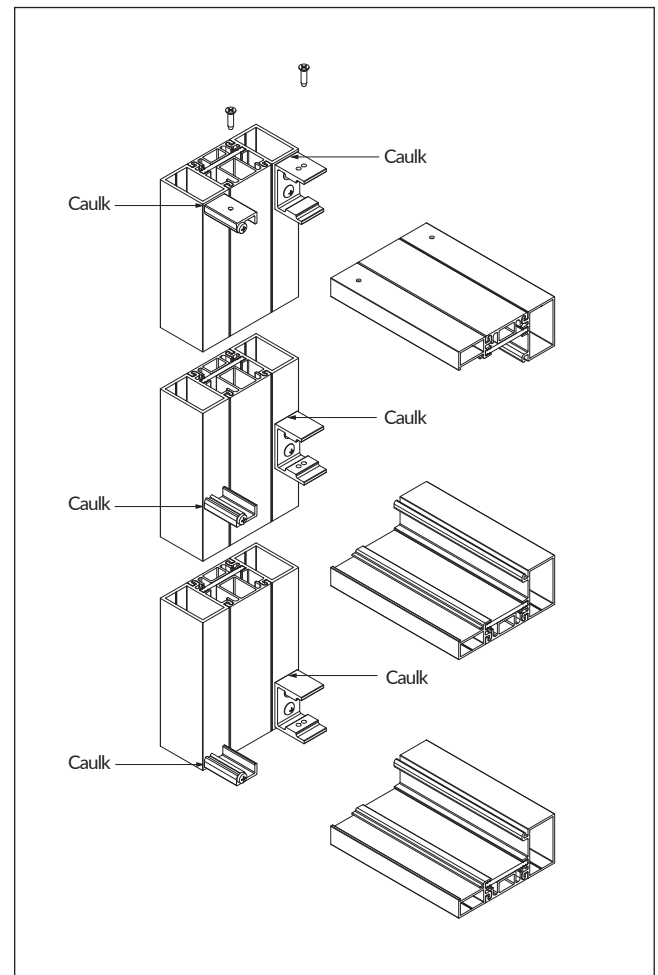

Sill Flashing

8. Cut Sill Flashing to fit between back of door jamb and sub-frame. Door Jamb does not set on sill flashing.
9. If using end dam, remove protective strip from double sided tape and press end dam in position. Apply caulk as shown.

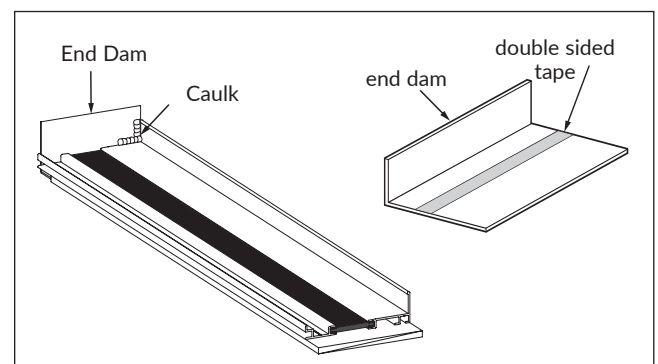

10. Install the sill flashing continuously between the door jambs location and the sub frame jambs.

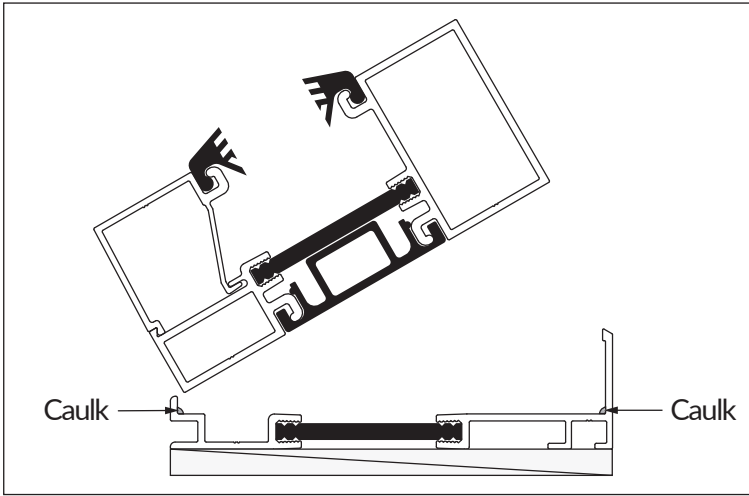

Adjust Frame Assembly Alignment

11. Place the threshold across the door opening (or use some other type of support the same length as the header) to keep the latch jamb and hinge jamb parallel.
12. Use tapered wood or composite shims to shim frame assembly into the opening. *Shims not provided by Special-Lite.*
13. With a level, make sure the door jambs are plumb and the header is level.
14. Shim frame at top and bottom corners only at this time. Do not install any mounting fasteners at this point. Doors must first be installed to allow proper frame adjustment.

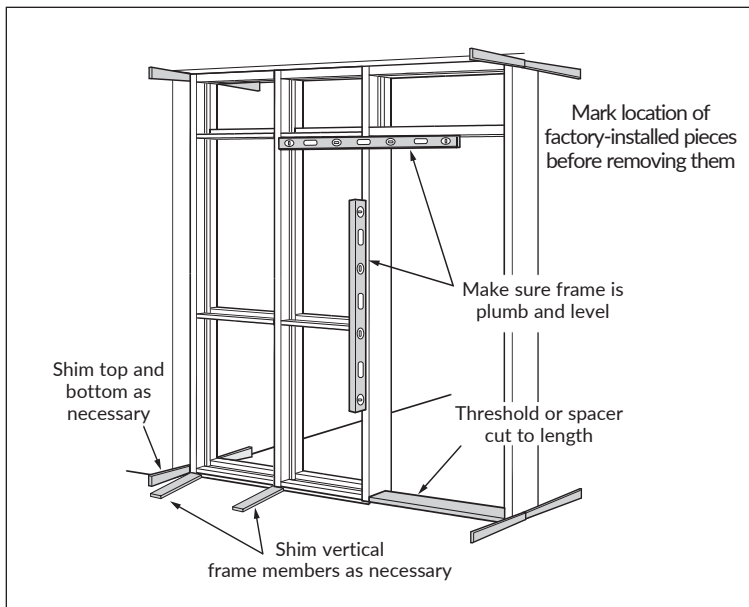

Note: Do not rely upon a visual check or a tape measure for accurate frame alignment. Use a professional-grade level.

Hang the Door(s)

15. Remove the door from the box. If hinge screw pack is placed under hinge leaf, open the hinge leaf and remove the pack and re-install screws that held the screw pack.

If the hinge was not installed at the factory, consult hinge manufacturer instructions for proper installation and install the hinge to the door now.

16. Hang door(s) in the frame with (3) screws in hinge jamb — one screw at top, middle and bottom.
17. Close door and check for Special-Lite recommended clearances:

- 1/8" at strike jamb on single doors
- 3/16" at mating stiles
- 1/8" at header. Adjust as needed.
- 1/8" with adjustable astregal

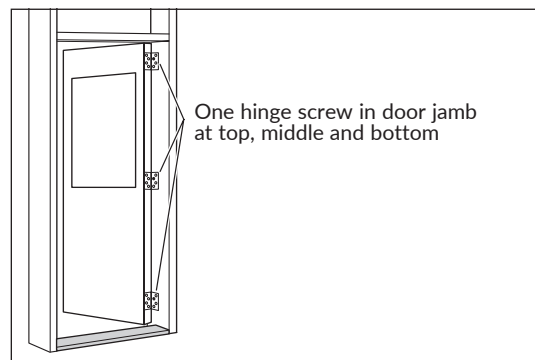
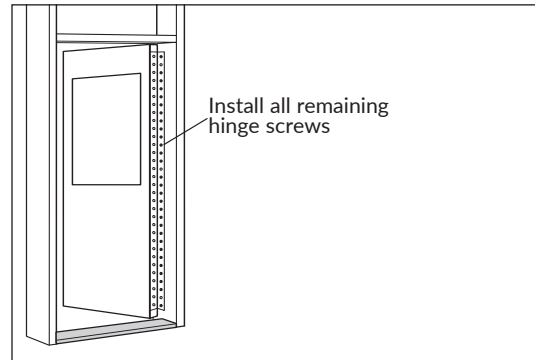

18. Check for alignment and make any adjustments to the frame to get the doors to align properly.
19. Install remaining hinge screws. Consult hinge manufacturer instructions for proper installation.

Note: Install pairs of doors in the same manner. If a meeting brush is used with pairs of doors, be sure to pull the string that holds the meeting brush rigid for shipping.

Mount Frame Assembly

20. Drill anchor holes for the fasteners into the subframe (rough opening) through the holes already drilled into the frame.
21. Place shims behind each frame-mounting hole location and at all horizontal frame locations.

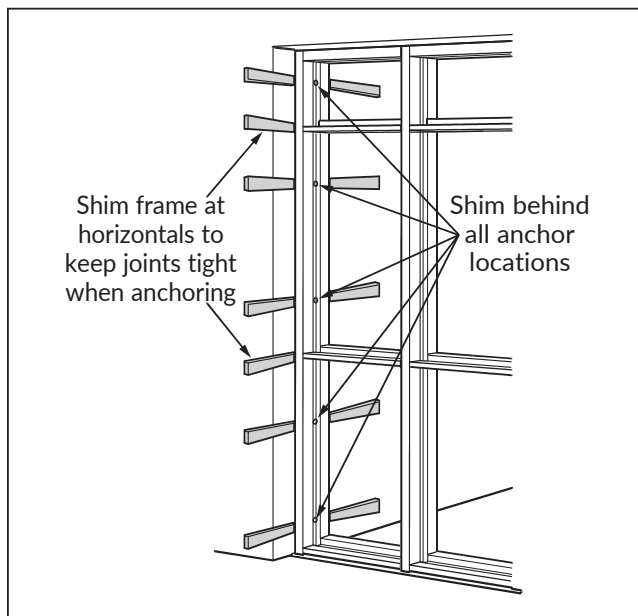

Note: Do not over tighten screws. Over tightening of the mounting screws could result in making the unit difficult to glaze. Do not over tighten shims.

22. Anchor the frame assembly using minimum 1/4" diameter fasteners that penetrate at least 1 to 1-1/2" into the rough opening. *Do not over tighten the mounting fasteners.*
23. When all anchor screws are installed, trim the shims flush to the frame.

24. Reapply the door stops that may have been removed earlier for drilling of mounting holes.
25. Apply caulk along the interior and exterior frame edges. Allow small gaps at the bottom of each vertical frame member for water to weep.
26. If a threshold is required, place in position and check for proper door clearance. Be sure to set threshold in caulk to prevent threshold from leaking. Secure threshold with appropriate fasteners. If you have an un-level threshold condition you may want to use Special-Lite's SL-301 Adjustable Bottom Brush.

Hardware Installation

27. Locate, mark, and install any door hardware that has not already been installed at the factory.

IMPORTANT: Do not drill closer mounting holes through tie rod in door. Observe cautions on door sticker (see example below).

Do not use tek screws on top closer fasteners, use standard 1/4-20 x 2" machine screws drilled and tapped.

28. Field adjustments may be necessary. All hardware must be field adjusted after door is hung, for proper function. (Strikes, closers, pivots, mullions, etc.)

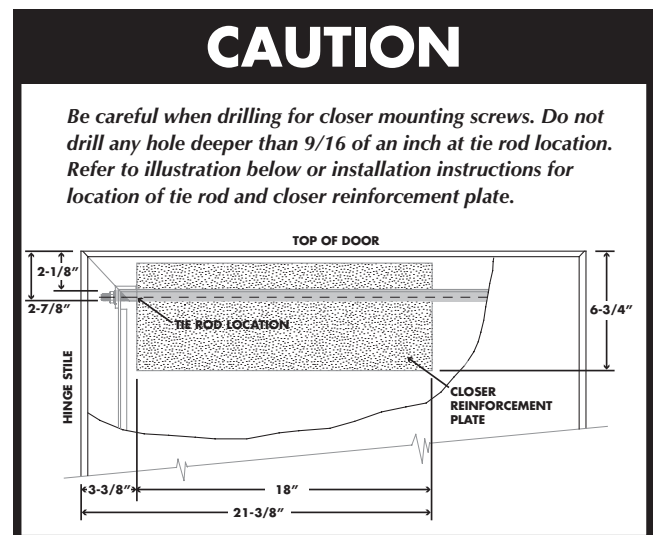

Caution Sticker applied to all flush doors

29. Install glazing gasket in all glass stops on interior side of framing. Compensate for shrinkage by compressing as much gasket as possible into the retaining channel and trim to length.
30. Sort all snap stops for each opening. Each opening will have a removable snap stop at the sill and horizontal intermediate frame members.
31. Install setting blocks at quarter points as needed.
32. Properly place glass or panel in position on setting blocks, centered side to side.
33. Install snap stops and remaining glazing gasket material.

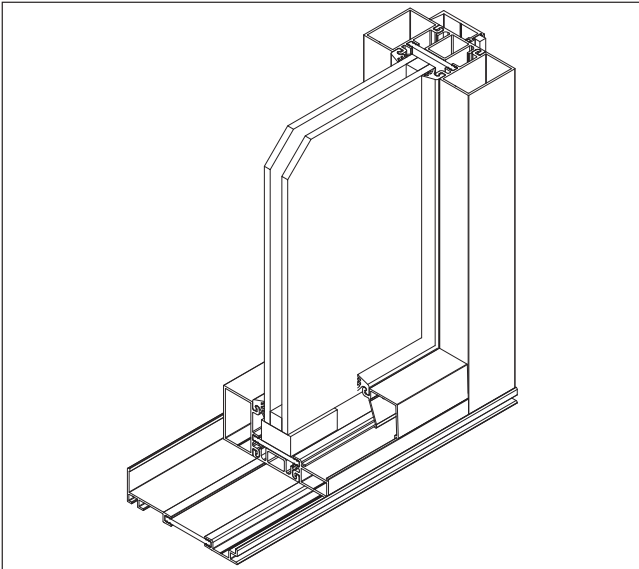

34. Install gasket in snap stops. Compensate for shrinkage by compressing as much excess gasket as possible into the retaining channel and trim to length.
35. If Special-Lite class "A" fire-rated skins on architectural panels are used, rated side of the panel is marked with a sticker indicating the interior side ONLY. Any pebble grain finish architectural panel or SL-17 flush door with Class A sheeting must be used on the interior side. If exposed to direct sunlight, Class "A" skin colors may discolor.
36. Remove all exposed production stickers from door(s) and frames. Be sure to leave production stickers on hinge side of door(s) and frames for future reference if needed. *For future door reference, do not remove hinge side production sticker.*

Door Glazing Procedure

Note: Special-Lite provides panel or glass sizes for most openings. Refer to the illustrations below for specific glazing applications.

The glazing procedure is as follows:

1. **Remove the interior glazing kit.**
This may include a glazing gasket, snap stop or kit with fasteners.
2. **Apply glazing tape.**
Glazing tape is supplied by Special-Lite. The tape will vary in width according to glazing specifications.
3. **Install setting blocks.**
Setting blocks are provided by Special-Lite.
4. **Fasten glass in position.**
Set glass into opening and reinstall interior glazing kit, snap stop or glazing bead. Tighten all fasteners.

Flush Door with 1/4" to 1" Glass

Note: Field-installed glazing seal should be applied to 3 sides on exterior of kit (not on bottom) and along bottom and 3" up sides on interior of kit.

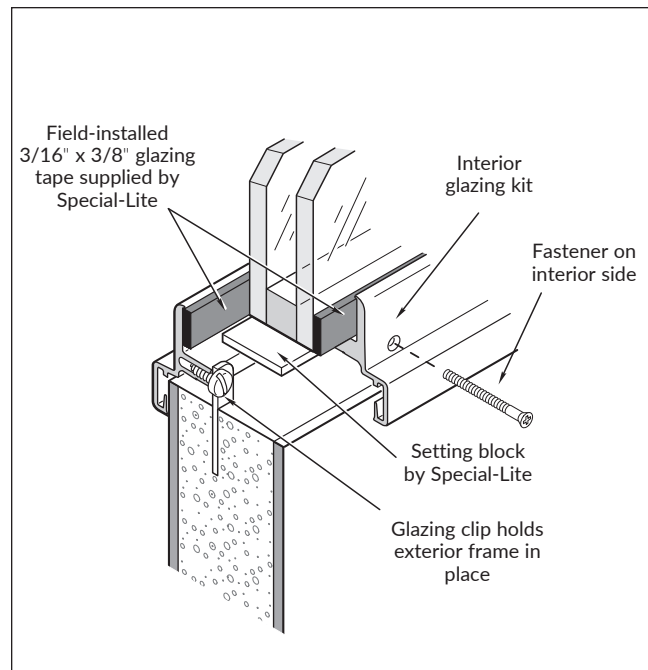

Monumental Door with 1/4" Glass

Glass size for 1/4" glass is daylight opening plus 9/16".

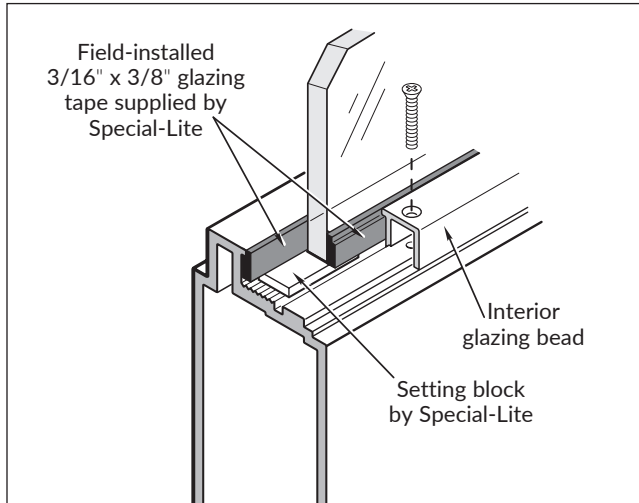

Monumental Door with 1" Glass

Glass size for 1" glass is daylight opening plus 7/8".

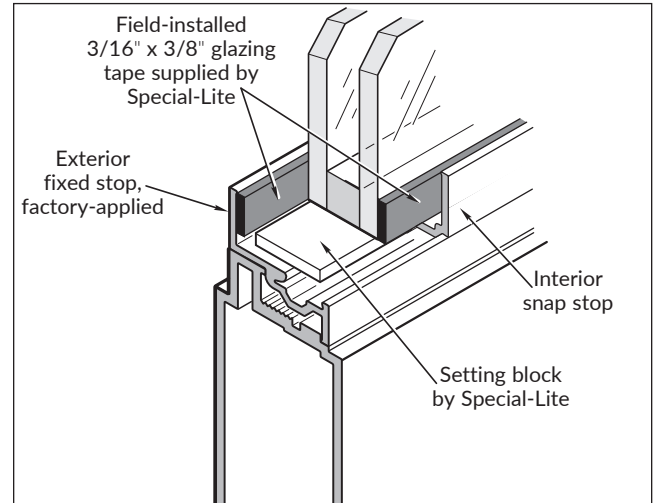

Monumental Door with 1/4" Glass and Surface-Applied Muntin Bars

A vision lite kit is required with muntins. Glass size for 1/4" glass is daylight opening plus 1".

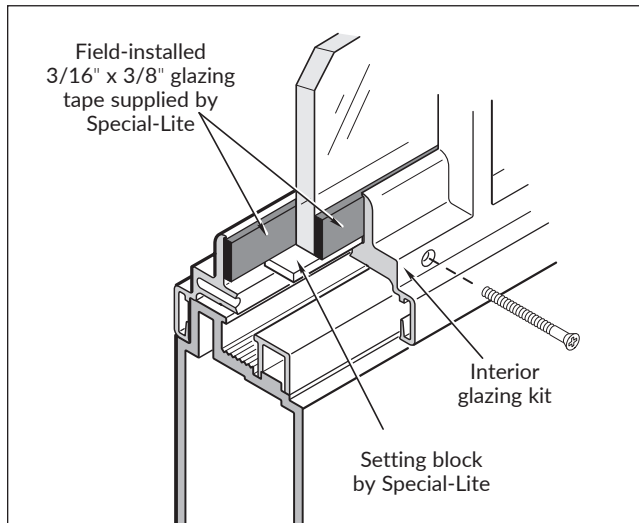

Special-Lite, Inc.
860 S. Williams St. Decatur, MI 49045

