

Thermostatic Control Valves

Model H

Typical applications

- Lubricating oil temperature control
- Jacket water high temperature (HT)
- Secondary water low temperature (LT)
- Heat recovery
- Water saving applications
- Boiler inlet temperature control
- Co-generation, cooling towers
- Temperature mixing or diverting
- Engine and compressor cooling system



H Valve

Key benefits

- No external power source required - simple, low cost installation
- No user setting needed - 'fit and forget' solution
- Small number of parts - simple maintenance and low cost of ownership
- Robust design capable of high vibration and shock applications
- Easy installation, operates in any mounting position
- Automatic self-sensing control with positive proportional valve action

Key features

- Flow rates of 56 - 280m³/hr (245 - 1232 US gpm)
- Combinations available: Housings in steel, stainless steel
- DN100 - DN150 (4 - 6") pipe size
- Flanged connections
- Tamper-proof temperature settings from 13°C to 116°C (55°F to 240°F)
- Pressure ratings:
 - 45 bar (655 psi) 4" only
 - 16 bar (230 psi)

Accreditations available

- PED* Suitable for Group 1 & 2 liquids (Ensure materials are compatible)
- ATEX*  11 2 G X
- CE* Complies with all relevant EU directives

* Contact AMOT



www.amot.com

Thermostatic Control Valves - Model H

Contents

Overview	3
Applications	4
Valve Characteristics	4
Pressure drop	5
Flow coefficient	6
Temperature & element characteristics	6
Available versions	6
How to order	7
Recommended spares	8
Specification	9
Dimensions	10
Weights	10

Thermostatic Control Valves - Model H

Overview

AMOT model H thermostatic valves are available in a wide selection of sizes and settings to fill a multitude of fluid temperature control requirements. These valves may be mounted in any position and use the proven expanding wax principle to actuate the 3-way temperature element assemblies. The model H valves may be used for diverting or mixing service. They make

very economical temperature limiting valves to prevent scalding in home, motel or hotel hot water supply systems. Radiant heating systems can use these valves in limiting water temperature to prevent surface cracking and over-heating of plastic piping. Other applications include electronic and battery cooling circuits, pump temperature relief valves etc.

Available housing materials

- Steel
- Stainless steel

Element materials

- Bronze, brass and stainless steel
- Nickel plated/Stainless steel

Seal materials

- Buna-N/Nitrile
- Viton

Leakholes

In some applications, it is necessary to have leak holes drilled in the element to ensure a small flow between ports A and C. Leak holes are available in sizes ranging from 6.3mm to 19mm (1/4 to 3/4"). Please refer to the Temperature Control Valve

Selection Guide (Datasheet_Temp_Control_Valve_Guide) to determine the hole size required for specific applications.

Temperature settings

A wide selection of element materials, seals, and temperatures are available. Follow the equipment manufacturers' guidelines for heating/cooling systems.

Temperature settings are available from 13°C to 116°C (55°F to 240°F). Refer to the Temperature & Element Characteristics table on page 6 for specific temperature settings. In general the temperature quoted is the nominal operating temperature in diverting mode on water systems.

For mixing and oil circuits the temperature may be one to two degrees higher due to flow, viscosity and other system parameters.

Elements and seals are available in a variety of materials. These materials are suitable for most applications. Please refer to the Temperature Control Valve Selection Guide (Datasheet_Temp_Control_Valve_Guide) for material compatibility information.

For long life, AMOT valves should not be operated continuously at temperatures in excess of 14°C (25°F) of their maximum continuous rating. If this condition is anticipated then consult AMOT for suitable alternatives.

Thermostatic Control Valves - Model H

Applications

Diverting Applications

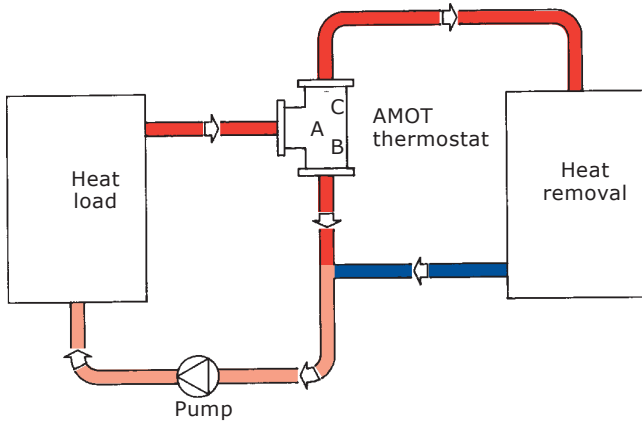

When valves are used for diverting service, the inlet is Port A (temperature sensing port), with Port C being connected to the cooler, and Port B connected to the cooler by-pass line.

Mixing Applications

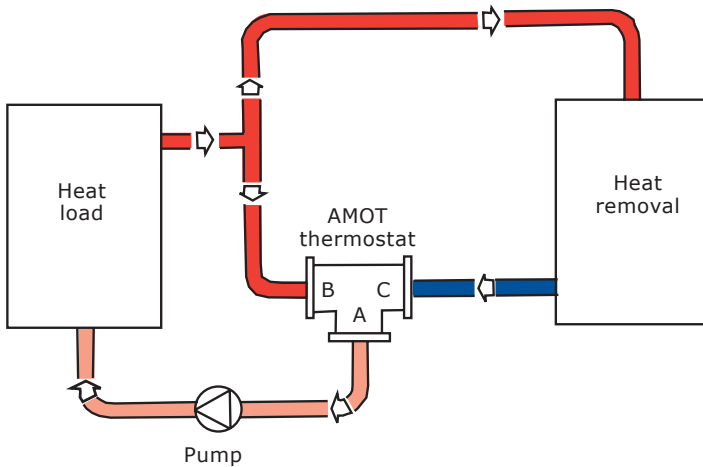

When valves are used for mixing service, Port C is the cold fluid inlet port from the cooler, Port B is the hot by-pass fluid inlet, and Port A the common outlet. Port A is the temperature sensing port and will mix the hot and cold fluids in the correct proportion so as to produce the desired outlet temperature leaving Port A.

2-way Water Saving Applications

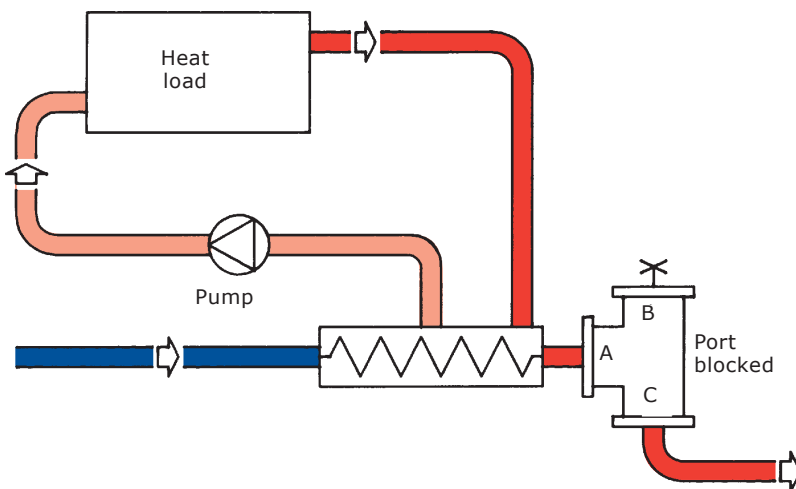

Valve as shown maintains minimum flow through cooler to conserve water. Requires internal leak hole to permit small flow for sensing.

Thermostatic Control Valves - Model H

Valve characteristics

Pressure drop - Metric Units

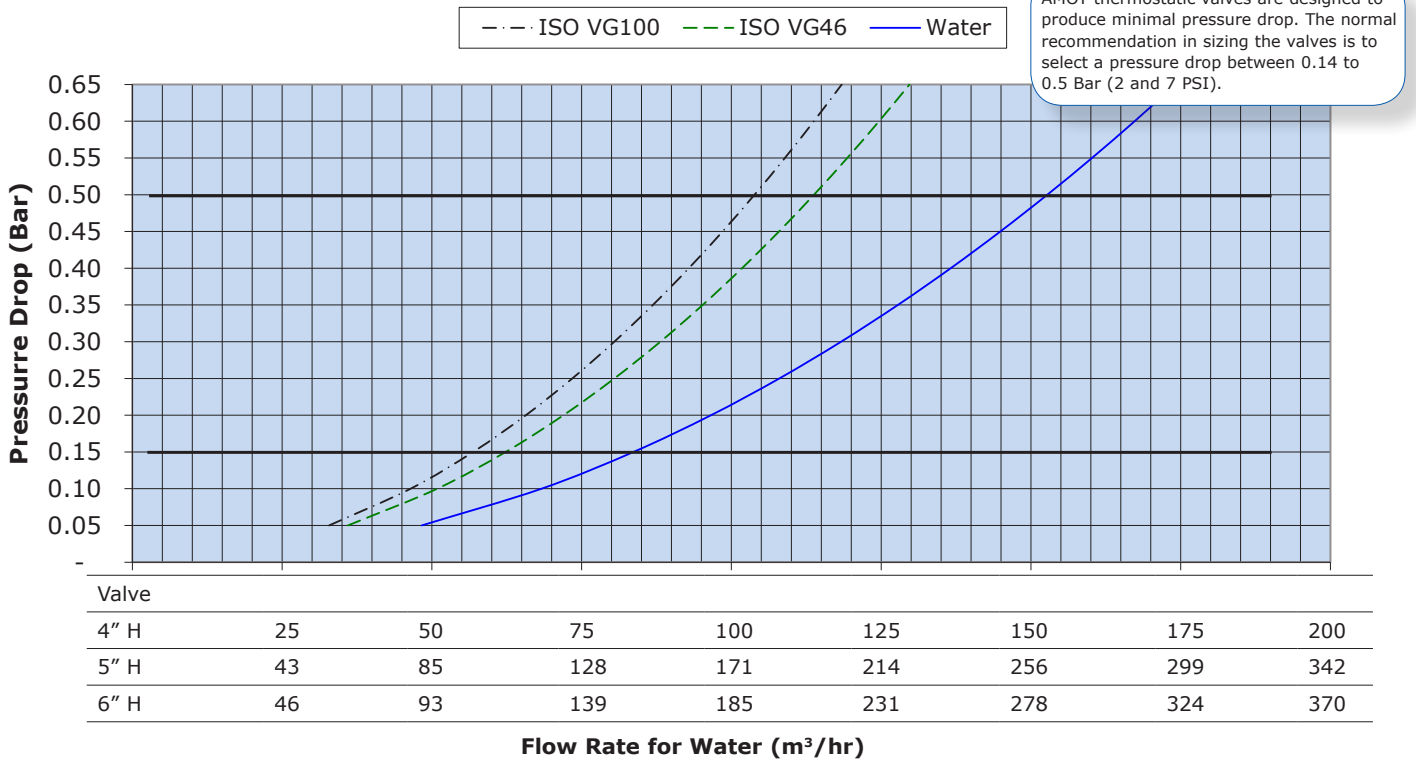

Pressure drop - English units

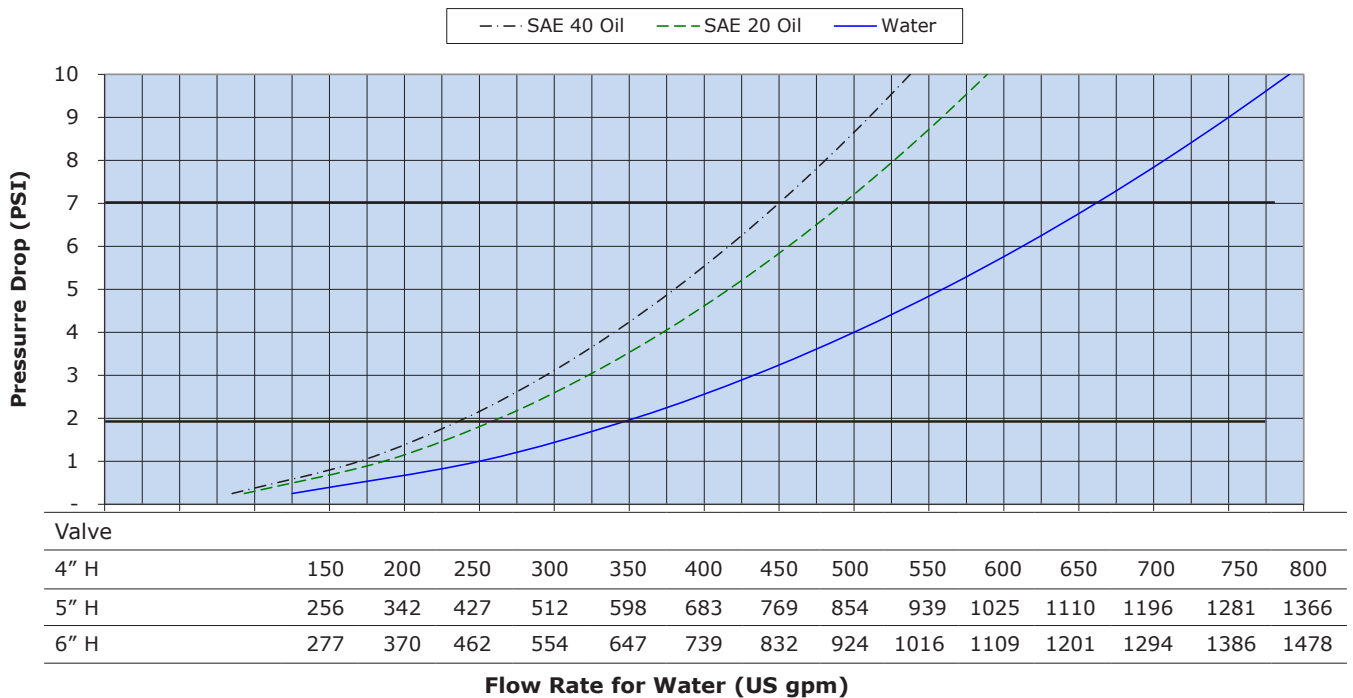

Thermostatic Control Valves - Model H

Valve characteristics

Flow coefficient

Flow coefficients (calculated)		
Size	Kv	Cv
4H	200	232
5H	400	464
6H	400	464

Kv is the flow coefficient in metric units. It is defined as the flow rate in cubic meters per hour (m³/h) of water at a temperature of 16° Celsius with a pressure drop across the valve of 1 bar. The basic formula to find a valve's Kv is shown below:

$$DP = \left(\frac{Q}{Kv}\right)^2 SG \quad Q = Kv \sqrt{\frac{DP}{SG}}$$

Q = Flow in m³/hr
 DP = Pressure drop (Bar)
 SG = Specific gravity of fluid (Water = 1.0)
 Kv = Valve flow coefficient

Cv is the flow coefficient in English units. It is defined as the flow rate in US Gallons per minute (gpm) of water at a temperature of 60° Fahrenheit with a pressure drop across the valve of 1 psi. The basic formula to find a valve's Cv is shown below:

$$DP = \left(\frac{Q}{Cv}\right)^2 SG \quad Q = Cv \sqrt{\frac{DP}{SG}}$$

Q = Flow in US gallons
 DP = Pressure drop (Psi)
 SG = Specific gravity of fluid (Water = 1.0)
 Cv = Valve flow coefficient

Temperature & element characteristics

Code	Control temp.		Rated range				Max temp. cont.	
	°C	°F	Crack open		Full open		°C	°F
			°C	°F	°C	°F		
055	13	55	8	47	20	68	35	95
075	24	75	20	68	30	86	38	100
090	32	90	27	81	35	95	43	110
095	35	95	29	85	41	105	49	120
100	38	100	34	94	42	108	50	122
105	41	105	35	95	45	113	55	131
110	43	110	38	100	47	117	56	133
115	46	115	40	104	50	122	61	142
120	49	120	43	110	54	130	66	150
130	54	130	51	124	60	140	68	155
135	57	135	54	129	63	145	71	160
140	60	140	57	135	66	151	74	165
150	66	150	63	145	72	161	82	180
155	68	155	66	150	74	165	85	185
160	71	160	68	155	78	173	88	190
165	74	165	71	160	79	175	88	190
170	77	170	74	165	83	181	93	200
175	79	175	77	170	85	185	102	215
180	82	180	79	175	88	191	104	220
195	91	195	86	188	98	209	107	225
205	96	205	93	200	102	215	108	226
215	102	215	98	209	107	225	115	239
230	110	230	104	219	116	239	118	244
240	116	240	108	227	122	252	123	254

Available versions

Steel and stainless steel ANSI 150 lb flanges	Steel and stainless steel ANSI 300 lb flanges
4HOSJ	4HOSH
4HMSJ	4HMSH
5HOSJ	
5HMSJ	
6HOSJ	
6HMSJ	

Thermostatic Control Valves - Model H

How to order

Use the tables below to select the unique specification of your H Valve.

Example Code	4	HO	S	H	120	03	-0	-AA	
Valve Size									
Valve Size	4							100 mm 4"	
	5							125 mm 5"	
	6							150 mm 6"	
Valve Model									
Valve Model	HO							Standard	
	HM							Manual override	
Valve Body Material									
Housing Material	S							Steel	
	R							Stainless steel	
Port Connection									
Port Connection	J							Flanged ANSI 150 lb	
	H							Flanged ANSI 300 lb (4" only)	
	B							Flanged PN10	
	C							Flanged PN16	
Control Temperature									
Control Temperature	055							13°C (55°F)	
	075							24°C (75°F)	
	090							32°C (90°F)	
	095							35°C (95°F)	
	100							38°C (100°F)	
	110							41°C (110°F)	
	115							43°C (115°F)	
	120							46°C (120°F)	
	130							54°C (130°F)	
	135							57°C (135°F)	
	140							60°C (140°F)	
	150							66°C (150°F)	
	155							68°C (155°F)	
	160							71°C (160°F)	
	165							74°C (165°F)	
	170							77°C (170°F)	
	175							79°C (175°F)	
180							82°C (180°F)		
195							91°C (195°F)		
205							96°C (205°F)		
215							102°C (215°F)		
230							110°C (230°F)		
240							116°C (240°F)		
Element & Seal Material									
Element & Seal Material	01							9760X Standard element, Buna N O-rings	
	02							9760P Nickel plated element and cage, Viton O-rings	
	03							9760X Standard element and cage, Viton O-rings	
	05							9760P Nickel plated element, Buna N O-Rings	
	07							9844X Standard manual override element, Buna N O-Rings	
	08							9844P Nickel plated manual override element and cage, Viton O-rings	
	09							9844X Standard manual override element, Viton O-rings	
	Leakhole Size								
	Leakhole Size	-0							None
-B								6.4 mm 1/4"	
-C								12.7 mm 1/2"	
-D								19 mm 3/4"	
Customer Special Code									
Customer Special Requirements	-AA							Standard Product	
	-***							Customer Special Code	

Thermostatic Control Valves - Model H

Recommended spares

Model HO

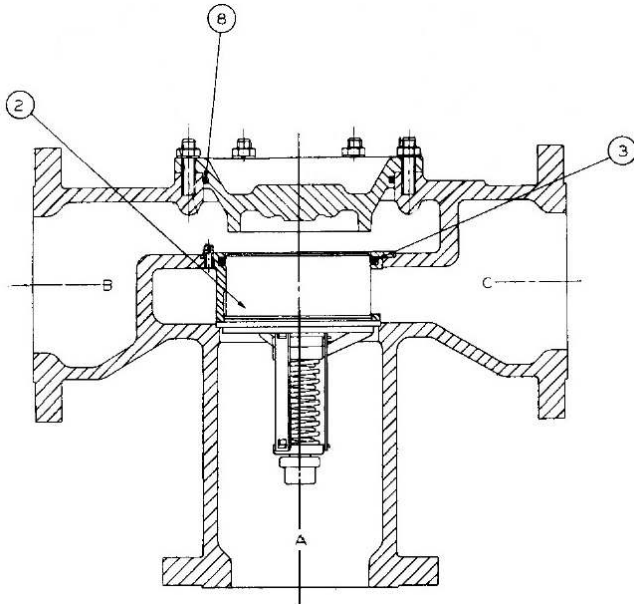

Replacement parts include:

- ② Element
- ③ O-ring
- ⑧ Housing O-ring seal

Model HM

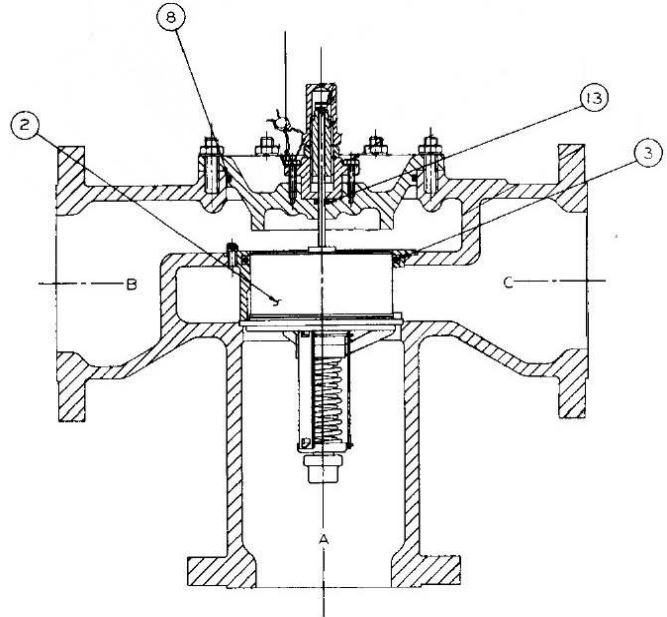

Replacement parts include:

- ② Element
- ③ O-ring
- ⑧ Housing O-ring seal, Buna N, Viton
- ⑬ O-ring, stem seal, Buna N, Viton

Ref no.	Part no.	Qty	Description
2	9760X (temp)	1 or 2	Element assembly
2	9760P (temp)	1 or 2	Element assembly, plated
2	9844 (temp)	1 or 2	Element assembly, manual override
3	11009L001	1 or 2	O-ring, element, Buna N (Std)
3	11009L002	1 or 2	O-ring, element Viton
8	11007L001	1 or 2	O-ring, housing, Buna N
8	11007L002	1 or 2	O-ring, housing, Viton
13	11148	1 or 2	O-ring, stem seal, Buna N
13	11148L001	1 or 2	O-ring, stem seal, Viton

When properly applied and installed, AMOT thermostatic valves should operate for years with minimal maintenance. An inspection at two or three year intervals is adequate to detect and make provision for normal wear. The frequency of element replacement will depend on the operating conditions and the type of fluid being controlled. Because of the diaphragm and plug construction of the wax actuated element, calibration will be maintained over thousands of cycles. Whenever elements are replaced, the O-ring seals should also be replaced. For convenience, elements and O-ring seals may be ordered together in the service kits listed below. The parts may also be ordered individually by their part number.

Thermostatic Control Valves - Model H

Specification

Flow rate	56 to 280m ³ /hr	(245 to 1232 US gpm)
Recommended pressure drop	0.14 to 0.5 bar	(2 to 7 PSI)
Body materials	Steel (BS: 3100 A1, WCB) Stainless steel	For high strength/pressure ratings
Seal materials	Nitrile Viton	
Mounting position	Any orientation	
Ports	Below nominal temperature Above nominal temperature	Ports A and B connected Ports A and C connected
Port connections	ANSI flanges	
Maximum working pressures	ANSI 150 lb ANSI 300 lb	16 bar (230 psi) 45 bar (655 psi) 4" valve only
Valve size (nominal bore)	100mm, 125mm and 150mm	(4", 5" and 6")
Control temperatures	13°C to 116°C See element characteristics table	55°F to 240°F
Accreditations*	PED ATEX 	Suitable for Group 1 & 2 liquids. (Ensure materials are compatible.) 11 2 G X Complies with all relevant EU directives

* Contact AMOT

Thermostatic Control Valves - Model H

Valve dimensions

Model HO and HM

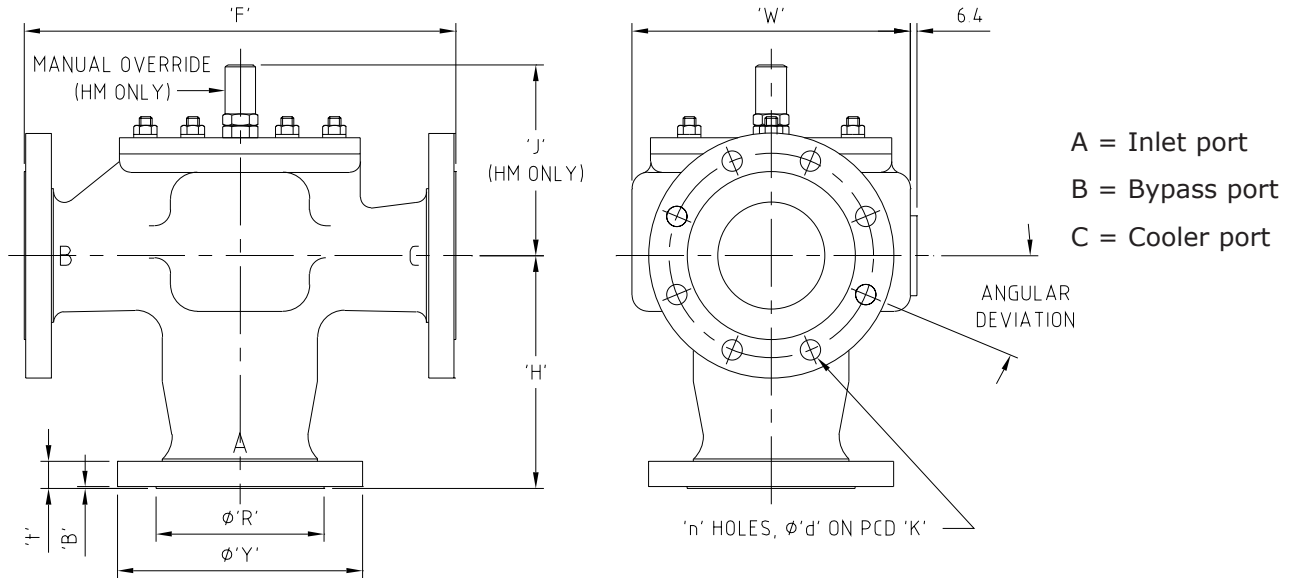

Dimensions (mm)

Dimension (mm)	4HOSJ/ HMSJ	4HOSH/ 4HMSH	5HOSJ/ 5HMSJ	6HOSJ/ HMSJ
Nominal bore	100	100	125	150
Y	229	254	254	279
R	157	157	186	216
B	1.5	1.5	1.5	1.5
F	403	414	489	489
t	24	32	24	26
H	218	224	279	279
W	260	260	463	463
J (HM only)	178	178	184	194

Flange drilling (mm)

Flange	4HOSJ/ HMSJ	4HOSH/ 4HMSH	5HOSJ/ 5HMSJ	6HOSJ/ HMSJ
d	19	22	22	22
K	191	198	216	241
n	8	8	8	8
Angular deviation	22.5°	22.5°	22.5°	22.5°

Weight Weights in kg (lbs)

Material	4HOSJ/ 4HMSJ	4HOSH/ 4HMSH	5HOSJ/ 5HMSJ	6HOSJ/ 6HMSJ
Weight	68 (150)	68 (150)	91 (200)	120 (265)

Americas

AMOT USA
8824 Fallbrook Dr
Houston, TX 77064
USA

Tel +1 (281) 940 1800
Fax +1 (713) 559 9419
Email general: sales@amotusa.com
orders: orders@amotusa.com
customer service: cs@amotusa.com

Asia and Australasia

AMOT Shanghai
Rm 4102 - 4104 United Plaza
1468 Nanjing Road West
Shanghai 200040
China

Tel +86 (0) 21 6279 7700
Fax +86 (0) 21 5237 8560
Email shanghai@amot.com

AMOT Singapore
10 Eunos Road 8 #12-06
Singapore Post Centre
Singapore 408600

Tel +65 6408 6265
Fax +65 6293 3307
Email singapore@amot.com

Europe, Middle East and Africa

AMOT
Western Way
Bury St Edmunds
Suffolk, IP33 3SZ
England

Tel +44 (0) 1284 762222
Fax +44 (0) 1284 760256
Email info@amot.com

AMOT Controls GmbH
Rondenbarg 25
22525 Hamburg
Germany

Tel +49 (0) 40 8537 1298
Fax +49 (0) 40 8537 1331
Email germany@amot.com

AMOT Russia
#34 Shabolovka Street
Building 2
Moscow 115419
Russia

Tel +7 495 617 12 93
Fax +7 495 913 97 65
Email russia@amot.com