

NEW AGE

# ENGINEERING MATHEMATICS-II



**A. GANESH • G. BALASUBRAMANIAN**



**NEW AGE INTERNATIONAL PUBLISHERS**

# **ENGINEERING MATHEMATICS-II**

**This page  
intentionally left  
blank**

# ENGINEERING MATHEMATICS-II

**A. GANESH**

Assistant Professor  
Department of Mathematics  
The Oxford College of Engineering  
Hosur Road, Bommanahally  
Bangalore

**G. BALASUBRAMANIAN**

Reader Department of Mathematics  
Govt. Arts College (Men)  
Krishangiri, Tamil Nadu



PUBLISHING FOR ONE WORLD

**NEW AGE INTERNATIONAL (P) LIMITED, PUBLISHERS**

New Delhi • Bangalore • Chennai • Cochin • Guwahati • Hyderabad  
Jalandhar • Kolkata • Lucknow • Mumbai • Ranchi

Visit us at [www.newagepublishers.com](http://www.newagepublishers.com)

Copyright © 2009, New Age International (P) Ltd., Publishers  
Published by New Age International (P) Ltd., Publishers

---

All rights reserved.

No part of this ebook may be reproduced in any form, by photostat, microfilm, xerography, or any other means, or incorporated into any information retrieval system, electronic or mechanical, without the written permission of the publisher.  
*All inquiries should be emailed to [rights@newagepublishers.com](mailto:rights@newagepublishers.com)*

**ISBN (13) : 978-81-224-2882-7**

**PUBLISHING FOR ONE WORLD**

**NEW AGE INTERNATIONAL (P) LIMITED, PUBLISHERS**

4835/24, Ansari Road, Daryaganj, New Delhi - 110002

Visit us at [www.newagepublishers.com](http://www.newagepublishers.com)

# ***Preface***

---

This Textbook has been prepared as per the syllabus for the Engineering Mathematics Second semester B.E classes of Visveswaraiah Technological University. The book contains eight chapters, and each chapter corresponds to one unit of the syllabus. The topics covered are: Unit I and II—Differential Calculus, Unit III and IV—Integral Calculus and Vector Integration, Unit V and VI—Differential Equations and Unit VII and VIII—Laplace Transforms.

It gives us a great pleasure in presenting this book. In this edition, the modifications have been dictated by the changes in the VTU syllabus. The main consideration in writing the book was to present the considerable requirements of the syllabus in as simple manner as possible. This will help students gain confidence in problem-solving.

Each unit treated in a systematic and logical presentation of solved examples is followed by an exercise section and includes latest model question papers with answers from an integral part of the text in which students will get enough questions for practice.

The book is designed as self-contained, comprehensive and friendly from students' point of view. Both theory and problems have been explained by using elegant diagrams wherever necessary.

We are grateful to New Age International (P) Limited, Publishers and the editorial department for their commitment and encouragement in bringing out this book within a short span of period.

**AUTHORS**

# ***Acknowledgement***

---

It gives us a great pleasure to present this book **ENGINEERING MATHEMATICS-II** as per the latest syllabus and question pattern of VTU effective from 2008-2009.

Let us take this opportunity to thank one and all who have actually given me all kinds of support directly and indirectly for bringing up my textbook.

We whole heartedly thank our Chairman Mr. S. Narasaraju Garu, Executive Director, Mr. S. Ramesh Raju Garu, Director Prof. Basavaraju, Principal Dr. T. Krishnan, HOD Dr. K. Mallikarjun, Dr. P.V.K. Perumal, Dr. M. Surekha, The Oxford College of Engineering, Bangalore. We would like to thank the other members of our Department, Prof. K. Bharathi, Prof. G. Padhmasudha, Mr. Ravikumar, Mr. Sivashankar and other staffs of The Oxford College of Engineering, Bangalore for the assistance they provided at all levels for bringing out this textbook successfully.

We must acknowledge Prof. M. Govindaiah, Principal, Prof. K.V. Narayana, Reader, Department of Mathematics, Vivekananda First Grade Degree College, Bangalore are the ones who truly made a difference in our life and inspired us a lot.

We must acknowledge HOD Prof. K. Rangasamy, Mr. C. Rangaraju, Dr. S. Murthy, Department of Mathematics, Govt. Arts College (Men), Krishnagiri.

We are also grateful to Dr. A.V. Satyanarayana, Vice-Principal of R.L. Jalappa Institute of Technology, Doddaballapur, Prof. A.S. Hariprasad, Sai Vidya Institute of Technology, Prof. V.K. Ravi, Mr. T. Saravanan, Bangalore college of Engineering and Technology, Prof. L. Satish, Raja Rajeshwari College of Engineering, Prof. M.R. Ramesh, S.S.E.T., Bangalore.

A very special thanks goes out to Mr. K.R. Venkataraj and Bros., our well wisher friend Mr. N. Aswathanarayana Setty, Mr. D. Srinivas Murthy without whose motivation and encouragement this could not have been completed.

We express our sincere gratitude to Managing Director, New Age International (P) Limited, and Bangalore Division Marketing Manager Mr. Sudharshan for their suggestions and provisions of the font materials evaluated in this study.

We would also like to thank our friends and students for exchanges of knowledge, skills during our course of time writing this book.

**AUTHORS**

*Dedicated to*

*my dear parents,*

*Shiridi Sai Baba,*

*my dear loving son Monish Sri Sai G  
and my wife and best friend S. Mamatha*

— *A. Ganesh*

*I*

*my dear parents,*

*and my wife S. Geetha*

— *G. Balasubramanian*



**This page  
intentionally left  
blank**

## QUESTION PAPER LAYOUT

### Engineering Mathematics-II

O6MAT21

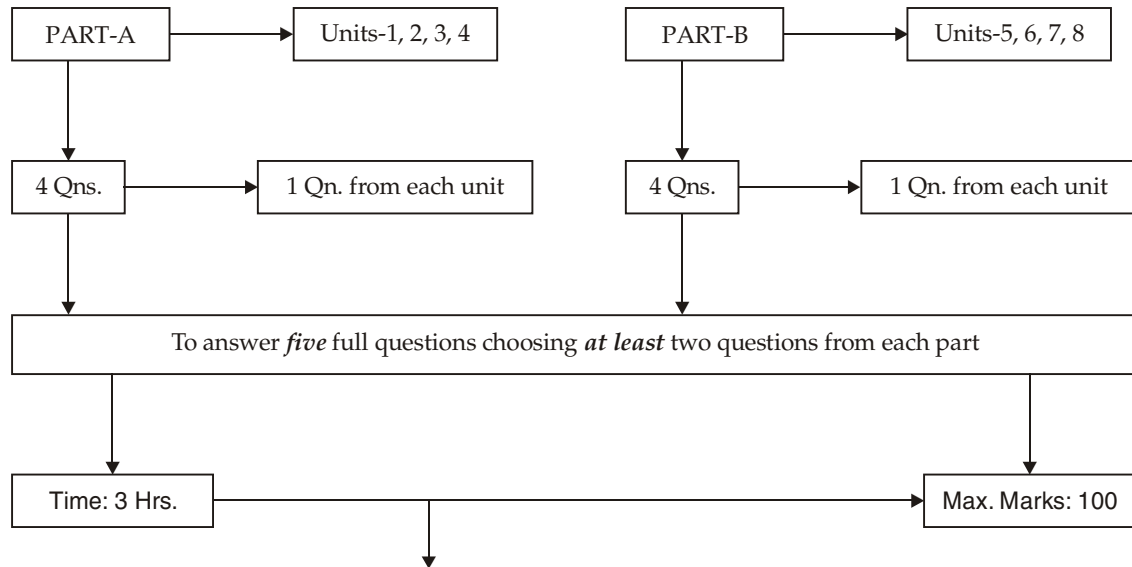

<i>Unit/Qn. No.</i>	<i>Topics</i>	<i>Unit/Qn. No.</i>	<i>Topics</i>
1.	DIFFERENTIAL CALCULUS-I Radius of Curvature: Cartesian curve Parametric curve, Pedal curve, Polar curve and some fundamental theorems.	5.	DIFFERENTIAL EQUATIONS-I Linear differential equation with constant coefficients, Solution of homogeneous and non homogeneous linear D.E., Inverse differential operator and the Particular Integral (P.I.) Method of undetermined coefficients.
2.	DIFFERENTIAL CALCULUS-II Taylor's, Maclaurin's Maxima and Minima for a function of two variables.	6.	DIFFERENTIAL EQUATIONS-II Method of variation of parameters, Solutions of Cauchy's homogeneous linear equation and Legendre's linear equation, Solution of initial and Boundary value problems.
3.	INTEGRAL CALCULUS-II Double and triple integral, Beta and Gamma functions.	7.	LAPLACE TRANSFORMS Periodic function, Unit step function (Heaviside function), Unit impulses function.
4.	VECTOR INTEGRATION AND ORTHOGONAL CURVILINEAR COORDINATES	8.	INVERSE LAPLACE TRANSFORMS Applications of Laplace transforms.

**This page  
intentionally left  
blank**

# Contents

---

PREFACE	(v)
ACKNOWLEDGEMENT	(vi)
<b>UNIT I Differential Calculus-I</b>	<b>1-60</b>
1.1 Introduction	1
1.2 Radius of Curvature	1
1.2.1 Radius of Curvature in Cartesian Form	2
1.2.2 Radius of Curvature in Parametric Form	3
<i>Worked Out Examples</i>	4
<i>Exercise 1.1</i>	18
1.2.3 Radius of Curvature in Pedal Form	19
1.2.4 Radius of Curvature in Polar Form	19
<i>Worked Out Examples</i>	21
<i>Exercise 1.2</i>	26
1.3 Some Fundamental Theorem	27
1.3.1 Rolle's Theorem	27
1.3.2 Lagrange's Mean Value Theorem	27
1.3.3 Cauchy's Mean Value Theorem	28
1.3.4 Taylor's Theorem	29
<i>Worked Out Examples</i>	30
<i>Exercise 1.3</i>	50
<i>Additional Problems (from Previous Years VTU Exams.)</i>	52
<i>Objective Questions</i>	57
<b>UNIT II Differential Calculus-II</b>	<b>61-104</b>
2.1 Indeterminate Forms	61
2.1.1 Indeterminate Form $\frac{0}{0}$	61
<i>Worked Out Examples</i>	62
<i>Exercise 2.1</i>	68
2.1.2 Indeterminate Forms $\infty - \infty$ and $0 \times \infty$	69
<i>Worked Out Examples</i>	69
<i>Exercises 2.2</i>	74
2.1.3 Indeterminate Forms $0^0, 1^\infty, \infty^0, 0^\infty$	74
<i>Worked Out Examples</i>	74
<i>Exercise 2.3</i>	77
2.2 Taylor's Theorem for Functions of Two Variables	78

<i>Worked Out Examples</i>	78
<i>Exercise 2.4</i>	82
2.3 Maxima and Minima of Functions of Two Variables	83
2.3.1 Necessary and Sufficient Conditions for Maxima and Minima	83
<i>Worked Out Examples</i>	84
<i>Exercise 2.5</i>	89
2.4 Lagrange's Method of Undetermined Multipliers	89
<i>Working Rules</i>	90
<i>Worked Out Examples</i>	91
<i>Exercise 2.6</i>	94
<i>Additional Problems (from Previous Years VTU Exams.)</i>	94
<i>Objective Questions</i>	101
<b>UNIT III Integral Calculus</b>	<b>105–165</b>
3.1 Introduction	105
3.2 Multiple Integrals	105
3.3 Double Integrals	105
<i>Worked Out Examples</i>	106
<i>Exercise 3.1</i>	112
3.3.1 Evaluation of a Double Integral by Changing the Order of Integration	113
3.3.2 Evaluation of a Double Integral by Change of Variables	113
3.3.3 Applications to Area and Volume	113
<i>Worked Out Examples</i>	114
Type 1. Evaluation over a given region	114
Type 2. Evaluation of a double integral by changing the order of integration	119
Type 3. Evaluation by changing into polars	122
Type 4. Applications of double and triple integrals	124
<i>Exercise 3.2</i>	128
3.4 Beta and Gamma Functions	129
3.4.1 Definitions	129
3.4.2 Properties of Beta and Gamma Functions	129
3.4.3 Relationship between Beta and Gamma functions	133
<i>Worked Out Examples</i>	135
<i>Exercise 3.3</i>	156
<i>Additional Problems (From Previous Years VTU Exams.)</i>	159
<i>Objective Questions</i>	162
<b>UNIT IV Vector Integration and Orthogonal Curvilinear Coordinates</b>	<b>166–213</b>
4.1 Introduction	166
4.2 Vector Integration	166
4.2.1 Vector Line Integral	166
<i>Worked Out Examples</i>	166
<i>Exercise 4.1</i>	172

4.3	Integral Theorem	173
4.3.1.	Green's Theorem in a Plane	173
4.3.2.	Surface Integral and Volume Integral	173
4.3.3.	Stoke's Theorem	174
4.3.4.	Gauss Divergence Theorem	174
	<i>Worked Out Examples</i>	174
	<i>Exercise 4.2</i>	188
4.4	Orthogonal Curvilinear Coordinates	189
4.4.1	Definition	189
4.4.2	Unit Tangent and Unit Normal Vectors	189
4.4.3.	The Differential Operators	191
	<i>Worked Out Examples</i>	192
	<i>Exercise 4.3</i>	194
4.4.4.	Divergence of a Vector	194
	<i>Worked out Examples</i>	195
	<i>Exercise 4.4</i>	196
4.4.5.	Curl of a Vector	196
	<i>Worked Out Examples</i>	197
	<i>Exercise 4.5</i>	198
4.4.6.	Expression for Laplacian $\nabla^2\psi$	199
4.4.7.	Particular Coordinate System	199
	<i>Worked Out Examples</i>	203
	<i>Exercise 4.6</i>	208
	<i>Additional Problems (From Previous Years VTU Exams.)</i>	208
	<i>Objective Questions</i>	210
<b>UNIT V</b>	<b>Differential Equations–I</b>	<b>214–279</b>
5.1	Introduction	214
5.2	Linear Differential Equations of Second and Higher Order with Constant Coefficients	214
5.3	Solution of a Homogeneous Second Order Linear Differential Equation	215
	<i>Worked Out Examples</i>	215
	<i>Exercise 5.1</i>	219
5.4	Inverse Differential Operator and Particular Integral	220
5.5	Special Forms of $x$	221
	<i>Worked Out Examples</i>	224
	<i>Exercise 5.2</i>	236
	<i>Exercise 5.3</i>	241
	<i>Exercise 5.4</i>	251
5.6	Method of Undetermined Coefficients	251
	<i>Worked Out Examples</i>	252
	<i>Exercise 5.5</i>	262

5.7 Solution of Simultaneous Differential equations	264
<i>Worked Out Examples</i>	265
<i>Exercise 5.6</i>	267
<i>Additional Problems (From Previous Years VTU Exams.)</i>	268
<i>Objective Questions</i>	277
<b>UNIT VI Differential Equations–I</b>	<b>280—320</b>
6.1 Method of Variation of Parameters	280
<i>Worked Out Examples</i>	281
<i>Exercise 6.1</i>	291
6.2 Solution of Cauchy’s Homogeneous Linear Equation and Lendgrendre’s Linear Equation	292
<i>Worked Out Examples</i>	294
<i>Exercise 6.2</i>	306
6.3 Solution of Initial and Boundary Value Problems	308
<i>Worked Out Examples</i>	308
<i>Exercise 6.3</i>	310
<i>Additional Problems (From Previous Years VTU Exams.)</i>	310
<i>Objective Questions</i>	318
<b>UNIT VII Laplace Transforms</b>	<b>321—368</b>
7.1 Introduction	321
7.2 Definition	321
7.3 Properties of Laplace Transforms	321
7.3.1 Laplace Transforms of Some Standard Functions	322
<i>Worked out Examples</i>	325
<i>Exercise 7.1</i>	330
7.3.2 Laplace Transforms of the form $e^{at} f(t)$	331
<i>Worked Out Examples</i>	332
<i>Exercise 7.2</i>	335
7.3.3 Laplace Transforms of the form $t^n f(t)$ where $n$ is a positive integer	336
7.3.4 Laplace Transforms of $\frac{f(t)}{t}$	337
<i>Worked out Examples</i>	337
<i>Exercise 7.3</i>	345
7.4 Laplace Transforms of Periodic Functions	346
<i>Worked Out Examples</i>	347
<i>Exercise 7.3</i>	351
7.5 Laplace Transforms of Unit Step Function and Unit Impulse Function	352
Unit Step Function (Heaviside Function)	352
7.5.1 Properties Associated with the Unit Step Function	352

7.5.2 Laplace Transform of the Unit Impulse Function	354
<i>Exercise 7.4</i>	359
<i>Additional Problems (From Previous Years VTU Exams.)</i>	360
<i>Objective Questions</i>	365
<b>UNIT VIII Inverse Laplace Transforms</b>	<b>369–426</b>
8.1 Introduction	369
8.2 Inverse Laplace Transforms of Some Standard Functions	369
<i>Worked Out Examples</i>	372
8.3 Inverse Laplace Transforms using Partial Fractions	376
<i>Exercise 8.1</i>	382
8.4 Inverse Laplace Transforms of the Functions of the Form $\frac{F(s)}{s}$	384
<i>Worked Out Example</i>	384
<i>Exercise 8.2</i>	387
8.5 Convolution Theorem	388
<i>Worked Out Examples</i>	389
<i>Exercise 8.3</i>	396
8.6 Laplace Transforms of the Derivatives	397
8.7 Solution of Linear Differential Equations	398
<i>Worked Out Examples</i>	398
Solution of Simultaneous Differential Equations	406
<i>Exercise 8.4</i>	410
8.8 Applications of Laplace Transforms	411
<i>Worked Out Examples</i>	412
<i>Exercise 8.5</i>	416
<i>Additional Problems (From Previous Years VTU Exams.)</i>	417
<i>Objective Questions</i>	422
<b>Model Question Paper–I</b>	<b>427–440</b>
<b>Model Question Paper–II</b>	<b>441–447</b>



**This page  
intentionally left  
blank**

# Differential Calculus—I

## 1.1 INTRODUCTION

In many practical situations engineers and scientists come across problems which involve quantities of varying nature. Calculus in general, and differential calculus in particular, provide the analyst with several mathematical tools and techniques in studying how the functions involved in the problem behave. The student may recall at this stage that the derivative, obtained through the basic operation of calculus, called differentiation, measures the rate of change of the functions (dependent variable) with respect to the independent variable. In this chapter we examine how the concept of the derivative can be adopted in the study of curvedness or bending of curves.

## 1.2 RADIUS OF CURVATURE

Let  $P$  be any point on the curve  $C$ . Draw the tangent at  $P$  to the circle. The circle having the same curvature as the curve at  $P$  touching the curve at  $P$ , is called the circle of curvature. It is also called the osculating circle. The centre of the circle of the curvature is called the centre of curvature. The radius of the circle of curvature is called the radius of curvature and is denoted by ' $\rho$ '.

**Note : 1.** If  $k (> 0)$  is the curvature of a curve at  $P$ , then the radius of curvature of the curve of  $\rho$  is  $\frac{1}{k}$ . This follows from the definition of radius of curvature and the result that the curvature of a circle is the reciprocal of its radius.

**Note : 2.** If for an arc of a curve,  $\psi$  decreases as  $s$  increases, then  $\frac{d\psi}{ds}$  is negative, i.e.,  $k$  is negative.

But the radius of a circle is non-negative. So to take  $\rho = \frac{1}{|k|} = \left| \frac{ds}{d\psi} \right|$  some authors regard  $k$  also as non-negative

i.e.,  $k = \left| \frac{d\psi}{ds} \right|$ .

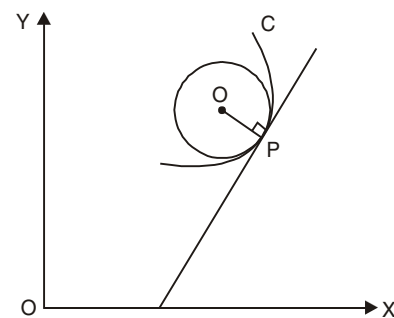

Fig. 1.1

The sign of  $\frac{d\psi}{ds}$  indicates the convexity and concavity of the curve in the neighbourhood of the point. Many authors take  $\rho = \frac{ds}{d\psi}$  and discard negative sign if computed value is negative.

$$\therefore \text{Radius of curvature } \rho = \frac{1}{|k|}.$$

### 1.2.1 Radius of Curvature in Cartesian Form

Suppose the Cartesian equation of the curve  $C$  is given by  $y = f(x)$  and  $A$  be a fixed point on it. Let  $P(x, y)$  be a given point on  $C$  such that arc  $AP = s$ .

Then we know that

$$\frac{dy}{dx} = \tan \psi \quad \dots(1)$$

where  $\psi$  is the angle made by the tangent to the curve  $C$  at  $P$  with the  $x$ -axis and

$$\frac{ds}{dx} = \left\{ 1 + \left( \frac{dy}{dx} \right)^2 \right\}^{\frac{1}{2}} \quad \dots(2)$$

Differentiating (1) w.r.t  $x$ , we get

$$\begin{aligned} \frac{d^2y}{dx^2} &= \sec^2 \psi \cdot \frac{d\psi}{dx} \\ &= (1 + \tan^2 \psi) \frac{d\psi}{ds} \cdot \frac{ds}{dx} \\ &= \left[ 1 + \left( \frac{dy}{dx} \right)^2 \right] \frac{1}{\rho} \left[ 1 + \left( \frac{dy}{dx} \right)^2 \right]^{\frac{1}{2}} \quad \text{[By using the (1) and (2)]} \\ &= \frac{1}{\rho} \left\{ 1 + \left( \frac{dy}{dx} \right)^2 \right\}^{\frac{3}{2}} \end{aligned}$$

Therefore,

$$\rho = \frac{\left\{ 1 + \left( \frac{dy}{dx} \right)^2 \right\}^{\frac{3}{2}}}{\frac{d^2y}{dx^2}} \quad \dots(3)$$

where  $y_1 = \frac{dy}{dx}$  and  $y_2 = \frac{d^2y}{dx^2}$ .

Equation (3) becomes,

$$\rho = \frac{\{1 + y_1^2\}^{\frac{3}{2}}}{y_2}$$

This is the Cartesian form of the radius of curvature of the curve  $y = f(x)$  at  $P(x, y)$  on it.

### 1.2.2 Radius of Curvature in Parametric Form

Let  $x = f(t)$  and  $y = g(t)$  be the Parametric equations of a curve  $C$  and  $P(x, y)$  be a given point on it.

Then 
$$\frac{dy}{dx} = \frac{dy/dt}{dx/dt} \quad \dots(4)$$

and 
$$\begin{aligned} \frac{d^2y}{dx^2} &= \frac{d}{dt} \left\{ \frac{dy/dt}{dx/dt} \right\} \cdot \frac{dt}{dx} \\ &= \frac{\frac{dx}{dt} \cdot \frac{d^2y}{dt^2} - \frac{dy}{dt} \cdot \frac{d^2x}{dt^2}}{\left(\frac{dx}{dt}\right)^2} \cdot \frac{1}{\frac{dx}{dt}} \\ \frac{d^2y}{dx^2} &= \frac{\frac{dx}{dt} \cdot \frac{d^2y}{dt^2} - \frac{dy}{dt} \cdot \frac{d^2x}{dt^2}}{\left(\frac{dx}{dt}\right)^3} \quad \dots(5) \end{aligned}$$

Substituting the values of  $\frac{dy}{dx}$  and  $\frac{d^2y}{dx^2}$  in the Cartesian form of the radius of curvature of the curve  $y = f(x)$  [Eqn. (3)]

$$\begin{aligned} \therefore \rho &= \frac{\{1 + y_1^2\}^{\frac{3}{2}}}{y_2} = \frac{\left\{1 + \left(\frac{dy}{dx}\right)^2\right\}^{\frac{3}{2}}}{\frac{d^2y}{dx^2}} \\ &= \frac{\left\{1 + \left(\frac{dy/dt}{dx/dt}\right)^2\right\}^{\frac{3}{2}}}{\frac{\left\{\frac{dx}{dt} \cdot \frac{d^2y}{dt^2} - \frac{dy}{dt} \cdot \frac{d^2x}{dt^2}\right\}}{\left(\frac{dx}{dt}\right)^3}} \\ \therefore \rho &= \frac{\left\{\left(\frac{dx}{dt}\right)^2 + \left(\frac{dy}{dt}\right)^2\right\}^{\frac{3}{2}}}{\frac{dx}{dt} \cdot \frac{d^2y}{dt^2} - \frac{dy}{dt} \cdot \frac{d^2x}{dt^2}} \quad \dots(6) \end{aligned}$$

where  $x' = \frac{dx}{dt}$ ,  $y' = \frac{dy}{dt}$ ,  $x'' = \frac{d^2x}{dt^2}$ ,  $y'' = \frac{d^2y}{dt^2}$

$$\rho = \frac{\{x'^2 + y'^2\}^{\frac{3}{2}}}{x'y'' - y'x''}$$

This is the cartesian form of the radius of curvature in parametric form.

### WORKED OUT EXAMPLES

1. Find the radius of curvature at any point on the curve  $y = a \log \sec \left( \frac{x}{a} \right)$ .

**Solution**

$$\text{Radius of curvature } \rho = \frac{\{1 + y_1^2\}^{\frac{3}{2}}}{y_2}$$

Here,  $y = a \log \sec \left( \frac{x}{a} \right)$

$$y_1 = a \times \frac{1}{\sec \left( \frac{x}{a} \right)} \cdot \sec \left( \frac{x}{a} \right) \tan \left( \frac{x}{a} \right) \cdot \frac{1}{a}$$

$$y_1 = \tan \left( \frac{x}{a} \right)$$

$$y_2 = \sec^2 \left( \frac{x}{a} \right) \cdot \frac{1}{a}$$

Hence 
$$\rho = \frac{\left\{ 1 + \tan^2 \left( \frac{x}{a} \right) \right\}^{\frac{3}{2}}}{\frac{1}{a} \sec^2 \left( \frac{x}{a} \right)}$$

$$\begin{aligned} &= \frac{\left\{ \sec^2 \left( \frac{x}{a} \right) \right\}^{3/2}}{\frac{1}{a} \sec^2 \left( \frac{x}{a} \right)} = \frac{a \sec^3 \left( \frac{x}{a} \right)}{\sec^2 \left( \frac{x}{a} \right)} \\ &= a \sec \left( \frac{x}{a} \right) \end{aligned}$$

$\therefore$  Radius of curvature =  $a \sec \left( \frac{x}{a} \right)$

2. For the curve  $y = c \operatorname{cosh} \left( \frac{x}{c} \right)$ , show that  $\rho = \frac{y^2}{c}$ .

**Solution** 
$$\rho = \frac{(1 + y_1^2)^{\frac{3}{2}}}{y_2}$$

Here, 
$$y = c \operatorname{cosh} \left( \frac{x}{c} \right)$$

$$y_1 = c \sinh \left( \frac{x}{c} \right) \times \frac{1}{c} = \sinh \left( \frac{x}{c} \right)$$

and 
$$y_2 = \operatorname{cosh} \left( \frac{x}{c} \right) \times \frac{1}{c}$$

$$\rho = \frac{\left\{ 1 + \sinh^2 \left( \frac{x}{c} \right) \right\}^{\frac{3}{2}}}{\frac{1}{c} \operatorname{cosh} \left( \frac{x}{c} \right)} = \frac{c \left( \operatorname{cosh}^2 \frac{x}{c} \right)^{\frac{3}{2}}}{\operatorname{cosh} \frac{x}{c}}$$

$$= c \operatorname{cosh}^2 \left( \frac{x}{c} \right) = \frac{1}{c} \left( c \operatorname{cosh} \left( \frac{x}{c} \right) \right)^2$$

$$= \frac{1}{c} \cdot y^2$$

$\therefore \rho = \frac{y^2}{c}$ . **Hence proved.**

3. Find the radius of curvature at  $(1, -1)$  on the curve  $y = x^2 - 3x + 1$ .

**Solution.** Where 
$$\rho = \frac{(1 + y_1^2)^{\frac{3}{2}}}{y_2} \text{ at } (1, -1)$$

Here, 
$$y = x^2 - 3x + 1$$

$$y_1 = 2x - 3, y_2 = 2$$

Now, 
$$(y_1)_{(1, -1)} = -1$$

$$(y_2)_{(1, -1)} = 2$$

$\therefore \rho_{(1, -1)} = \frac{(1 + 1)^{\frac{3}{2}}}{2} = \frac{2\sqrt{2}}{2}$   

$$= \sqrt{2}$$

4. Find the radius of curvature at  $(a, 0)$  on  $y = x^3 (x - a)$ .

**Solution.** We have 
$$\rho = \frac{(1 + y_1^2)^{\frac{3}{2}}}{y_2} \text{ at } (a, 0)$$

Here,  $y = x^3(x - a) = x^4 - x^3a$

$$y_1 = 4x^3 - 3ax^2$$

and

$$y_2 = 12x^2 - 6ax$$

Now

$$(y_1)_{(a, 0)} = 4a^3 - 3a^3 = a^3$$

$$(y_2)_{(a, 0)} = 12a^2 - 6a^2 = 6a^2$$

$$\begin{aligned} \therefore \rho_{(a, 0)} &= \frac{\left\{1 + (a^3)^2\right\}^{\frac{3}{2}}}{6a^2} \\ &= \frac{\left\{1 + a^6\right\}^{\frac{3}{2}}}{6a^2}. \end{aligned}$$

5. Find the radius of curvature at  $x = \frac{\pi a}{4}$  on  $y = a \sec\left(\frac{x}{a}\right)$ .

**Solution.** We have  $\rho = \frac{(1 + y_1^2)^{\frac{3}{2}}}{y_2}$  at  $x = \frac{\pi a}{4}$

Here  $y = a \sec\left(\frac{x}{a}\right)$

$$\therefore y_1 = a \sec\left(\frac{x}{a}\right) \cdot \tan\left(\frac{x}{a}\right) \times \frac{1}{a}$$

$$y_1 = \sec\left(\frac{x}{a}\right) \tan\left(\frac{x}{a}\right)$$

and  $y_2 = \sec^3 \frac{x}{a} \times \frac{1}{a} + \sec\left(\frac{x}{a}\right) \cdot \tan^2\left(\frac{x}{a}\right) \cdot \frac{1}{a}$

$$= \frac{1}{a} \left[ \sec^3\left(\frac{x}{a}\right) + \sec\left(\frac{x}{a}\right) \tan^2\left(\frac{x}{a}\right) \right]$$

$$\text{At } x = \frac{\pi a}{4}, y_1 = \sec \frac{\pi}{4} \cdot \tan \frac{\pi}{4} = \sqrt{2}$$

$$\text{and } y_2 = \frac{1}{a} (2\sqrt{2} + \sqrt{2}) = \frac{3\sqrt{2}}{a}$$

$$\begin{aligned} \therefore \rho_{x=\frac{\pi a}{4}} &= \frac{\left\{1 + (\sqrt{2})^2\right\}^{\frac{3}{2}}}{\frac{3\sqrt{2}}{a}} = \frac{3\sqrt{3}}{3\sqrt{2}} \cdot a \\ &= \sqrt{\frac{3}{2}} a. \end{aligned}$$

6. Find  $\rho$  at  $x = \frac{\pi}{3}$  on  $y = 2 \log \sin \left( \frac{x}{2} \right)$ .

**Solution.** We have  $\rho = \frac{(1 + y_1^2)^{\frac{3}{2}}}{y_2}$  at  $x = \frac{\pi}{3}$

The curve is  $y = 2 \log \sin \left( \frac{x}{2} \right)$

$$\begin{aligned} y_1 &= 2 \cdot \frac{1}{\sin \left( \frac{x}{2} \right)} \times \cos \left( \frac{x}{2} \right) \times \frac{1}{2} \\ &= \cot \left( \frac{x}{2} \right) \end{aligned}$$

and  $y_2 = -\operatorname{cosec}^2 \left( \frac{x}{2} \right) \times \frac{1}{2}$

At  $x = \frac{\pi}{3}$ ,  $y_1 = \cot \left( \frac{\pi}{6} \right) = \sqrt{3}$

and  $y_2 = \frac{-1}{2} \operatorname{cosec}^2 \frac{\pi}{6} = -2$

$$\begin{aligned} \therefore \rho_{x=\frac{\pi}{3}} &= \frac{\left\{ 1 + (\sqrt{3})^2 \right\}^{\frac{3}{2}}}{-2} \\ &= \frac{(1+3)^{\frac{3}{2}}}{-2} = \frac{4 \times 2}{-2} = -4. \end{aligned}$$

7. Find the radius of curvature at  $\left( \frac{3a}{2}, \frac{3a}{2} \right)$  on  $x^3 + y^3 = 3axy$ .

**Solution.** We have  $\rho = \frac{\{1 + y_1^2\}^{\frac{3}{2}}}{y_2}$  at  $\left( \frac{3a}{2}, \frac{3a}{2} \right)$ .

Here,  $x^3 + y^3 = 3axy$

Differentiating with respect to  $x$

$$3x^2 + 3y^2 y_1 = 3a (xy_1 + y)$$

$$3 (y^2 - ax) y_1 = 3 (ay - x^2)$$

$$\Rightarrow y_1 = \frac{ay - x^2}{y^2 - ax} \quad \dots(1)$$



Again differentiating w.r.t  $x$ .

$$\Rightarrow y_2 = \frac{(y^2 - ax) \cdot (ay_1 - 2x) - (ay - x^2)(2yy_1 - a)}{(y^2 - ax)^2} \quad \dots(2)$$

Now, from (1), at  $\left(\frac{3a}{2}, \frac{3a}{2}\right)$

$$\begin{aligned} y_1 &= \frac{a\left(\frac{3a}{2}\right) - \left(\frac{3a}{2}\right)^2}{\left(\frac{3a}{2}\right)^2 - a\left(\frac{3a}{2}\right)} \\ &= \frac{6a^2 - 9a^2}{9a^2 - 6a^2} \\ &= \frac{-(9a^2 - 6a^2)}{(9a^2 - 6a^2)} = -1 \end{aligned}$$

From (2), at  $\left(\frac{3a}{2}, \frac{3a}{2}\right)$

$$\begin{aligned} y_2 &= \frac{\left(\frac{9a^2}{2} - \frac{3a^2}{2}\right)(-a - 3a) - \left(\frac{3a^2}{2} - \frac{9a^2}{4}\right)(-3a - a)}{\left(\frac{9a^2}{4} - \frac{3a^2}{2}\right)^2} \\ &= \frac{-\frac{3}{4}a^2 \times 4a - \frac{3a^2}{4} \times 4a}{\left(\frac{3a^2}{4}\right)^2} \\ &= \frac{-6a^3}{9a^4} = \frac{-32}{16} \end{aligned}$$

Using these

$$\begin{aligned} \rho\left(\frac{3a}{2}, \frac{3a}{2}\right) &= \frac{\{1 + (-1)^2\}^{\frac{3}{2}}}{\left(-\frac{32}{3a}\right)} \\ &= -\frac{2\sqrt{2} \times 3a}{32} = \frac{-3a}{8\sqrt{2}} \end{aligned}$$

$\therefore$  Radius of curvature at  $\left(\frac{3a}{2}, \frac{3a}{2}\right)$  is  $\frac{3a}{8\sqrt{2}}$ .

8. Find the radius of curvature of  $b^2x^2 + a^2y^2 = a^2b^2$  at its point of intersection with the y-axis.

**Solution.** We have  $\rho = \frac{\{1 + y_1^2\}^{\frac{3}{2}}}{y_2}$  at  $x = 0$

$$\text{Here, } b^2x^2 + a^2y^2 = a^2b^2$$

$$\text{When } x = 0, \quad a^2y^2 = a^2b^2$$

$$y^2 = b^2$$

$$\Rightarrow y = \pm b$$

i.e., the point is  $(0, b)$  or  $(0, -b)$

$$\text{The curve is } b^2x^2 + a^2y^2 = a^2b^2.$$

Differentiating w.r. to  $x$

$$2b^2x + 2a^2yy_1 = 0$$

$$y_1 = -\frac{b^2x}{a^2y}$$

Differentiating again w.r. to  $x$

$$y_2 = \frac{-b^2}{a^2} \left( \frac{y - xy_1}{y^2} \right)$$

$$\text{Now at } (0, b), \quad y_1 = \frac{-b^2(0)}{a^2(b)} = 0$$

$$\begin{aligned} \text{and } y_2 &= \frac{-b^2}{a^2} \left( \frac{b - 0}{b^2} \right) \\ &= \frac{-b}{a^2} \end{aligned}$$

i.e., Radius of curvature at  $(0, b)$  is

$$\therefore \rho_{(0, b)} = \frac{(1+0)^{\frac{3}{2}}}{\left(\frac{-b}{a^2}\right)} = \frac{-a^2}{b}$$

$$\therefore \text{Radius of curvature is } \frac{a^2}{b}$$

Next consider  $(0, -b)$ ,

$$y_1 = \frac{-b^2}{a^2} \times \frac{0}{-b} = 0$$

$$y_2 = \frac{-b^2}{a^2} \left( \frac{-b - 0}{b^2} \right) = \frac{a^2}{b}$$

$$\rho_{(0, -b)} = \frac{(1+0)^{\frac{3}{2}}}{\left(\frac{b}{a^2}\right)} = \frac{a^2}{b}$$

$\therefore$  Radius of curvature of  $(0, -b)$  is  $\frac{a^2}{b}$ .

9. Show that at any point  $P$  on the rectangular hyperbola  $xy = c^2$ ,  $\rho = \frac{r^3}{2c^2}$  where  $r$  is the distance of the point from the origin.

**Solution.** The curve is  $xy = c^2$

Differentiating w.r. to  $x$

$$xy_1 + y = 0$$

$$y_1 = -\frac{y}{x}$$

Again differentiating w.r.t.  $x$

$$\begin{aligned} y_2 &= -\left\{\frac{xy_1 - y}{x^2}\right\} \\ &= -\left\{\frac{-\frac{xy}{x} - y}{x^2}\right\} = \frac{2y}{x^2} \end{aligned}$$

$$\begin{aligned} \rho &= \frac{(1+y_1^2)^{\frac{3}{2}}}{y_2} = \frac{\left\{1+\left(\frac{y}{x}\right)^2\right\}^{\frac{3}{2}}}{\frac{2y}{x^2}} \\ &= \frac{(x^2+y^2)^{\frac{3}{2}}}{x^3 \times \frac{2y}{x^2}} \\ &= \frac{(x^2+y^2)^{\frac{3}{2}}}{2xy} \end{aligned}$$

where  $x^2 + y^2 = r^2$  and  $xy = c^2$ .

$$\therefore \rho = \frac{r^3}{2c^2}.$$

10. Show that, for the ellipse  $\frac{x^2}{a^2} + \frac{y^2}{b^2} = 1$ ,  $\rho = \frac{a^2b^2}{p^3}$  where  $p$  is the length of the perpendicular from the centre upon the tangent at  $(x, y)$  to the ellipse.

**Solution.** The ellipse is  $\frac{x^2}{a^2} + \frac{y^2}{b^2} = 1$

Differentiating w.r.t.  $x$

$$\frac{2x}{a^2} + \frac{2yy_1}{b^2} = 0$$

$$\Rightarrow y_1 = -\frac{b^2}{a^2} \frac{x}{y}$$

Again Differentiating w.r. to  $x$

$$y_2 = \frac{-b^2}{a^2} \left[ \frac{y - xy_1}{y^2} \right]$$

$$= \frac{-b^2}{a^2} \left[ \frac{y + \frac{b^2}{a^2} \cdot \frac{x^2}{y}}{y^2} \right]$$

$$= -\frac{b^4}{a^2 y^3} \left[ \frac{y^2}{b^2} + \frac{x^2}{a^2} \right]$$

$$y_2 = \frac{-b^4}{a^2 y^3} \left[ \because \frac{x^2}{a^2} + \frac{y^2}{b^2} = 1 \right]$$

Now,

$$\rho = \frac{\{1 + y_1^2\}^{\frac{3}{2}}}{y_2} = \frac{\left(1 + \frac{b^4 x^2}{a^4 x^2}\right)^{\frac{3}{2}}}{\left(-\frac{b^4}{a^2 y^3}\right)}$$

$$= -\frac{(a^4 y^2 + b^4 x^2)^{\frac{3}{2}}}{a^6 y^3} \times \frac{a^2 y^3}{b^4}$$

$$\rho = -\frac{(a^4 y^2 + b^4 x^2)^{\frac{3}{2}}}{a^4 b^4}$$

Taking magnitude  $|\rho| = \frac{(a^4 y^2 + b^4 x^2)^{\frac{3}{2}}}{a^4 b^4} \dots(1)$

The tangent at  $(x_0, y_0)$  to the ellipse  $\frac{x^2}{a^2} + \frac{y^2}{b^2} = 1$  is

$$\frac{x x_0}{a^2} + \frac{y y_0}{b^2} = 1$$

Length of perpendicular from (0, 0) upon this tangent

$$= \frac{1}{\sqrt{\left(\frac{x_0}{a^2}\right)^2 + \left(\frac{y_0}{b^2}\right)^2}}$$

$$= \frac{a^2 b^2}{\sqrt{a^4 y_0^2 + b^4 x_0^2}}$$

So, the length of perpendicular from the origin upon the tangent at (x, y) is

$$p = \frac{a^2 b^2}{\sqrt{a^4 y_0^2 + b^4 x_0^2}}$$

By replacing  $x_0$  by  $x$  and  $y_0$  by  $y$

$$p = \frac{a^2 b^2}{\sqrt{a^4 y^2 + b^4 x^2}}$$

Reciprocal and cube on both sides, we get,

$$\Rightarrow \frac{1}{p^3} = \frac{(a^4 y^2 + b^4 x^2)^{\frac{3}{2}}}{a^6 b^6}$$

$$= \frac{(a^4 y^2 + b^4 x^2)^{\frac{3}{2}}}{a^4 b^4} \times \frac{1}{a^2 b^2}$$

By using eq. (1), we get

$$\frac{1}{p^3} = \frac{\rho}{a^2 b^2}$$

$$\Rightarrow \rho = \frac{a^2 b^2}{p^3}.$$

**11.** Show that, for the curve  $y = \frac{ax}{a+x}$ ,  $\left(\frac{2\rho}{a}\right)^{\frac{2}{3}} = \left(\frac{x}{y}\right)^2 + \left(\frac{y}{x}\right)^2$ .

**Solution.** Here,  $y = \frac{ax}{a+x}$

Differentiating w.r.t.  $x$

$$y_1 = a \left[ \frac{(a+x)(1) - x}{(a+x)^2} \right] = \frac{a^2}{(a+x)^2}$$

Again Differentiating w.r.t.  $x$

$$y_2 = a^2 \frac{-2}{(a+x)^3} = \frac{-2a^2}{(a+x)^3}$$

Now, 
$$\rho = \frac{(1 + y_1^2)^{\frac{3}{2}}}{y_2}$$

Substituting  $y_1$  and  $y_2$ , we get

$$\begin{aligned} &= \frac{\left\{1 + \frac{a^4}{(a+x)^4}\right\}^{\frac{3}{2}}}{\left\{-\frac{2a^2}{(a+x)^3}\right\}} \\ \rho &= -\frac{\left\{(a+x)^4 + a^4\right\}^{\frac{3}{2}}}{2a^2(a+x)^3} \end{aligned} \quad \dots(1)$$

To show that 
$$\left(\frac{2\rho}{a}\right)^{\frac{2}{3}} = \left(\frac{x}{y}\right)^2 + \left(\frac{y}{x}\right)^2$$

L.H.S. 
$$\begin{aligned} \left(\frac{2\rho}{a}\right)^{\frac{2}{3}} &= \left\{\frac{2\left\{(a+x)^4 + a^4\right\}^{\frac{3}{2}}}{2a^3(a+x)^3}\right\}^{\frac{2}{3}} \text{ using (1)} \\ &= \frac{(a+x)^4 + a^4}{a^2(a+x)^2} \\ &= \frac{(a+x)^2}{a^2} + \frac{a^2}{(a+x)^2} \end{aligned} \quad \dots(2)$$

R.H.S. 
$$\begin{aligned} &= \left(\frac{x}{y}\right)^2 + \left(\frac{y}{x}\right)^2 \\ &= \left\{\frac{x}{\left(\frac{ax}{a+x}\right)}\right\}^2 + \left\{\frac{\left(\frac{ax}{a+x}\right)}{x}\right\}^2 \\ &= \frac{(a+x)^2}{a^2} + \frac{a^2}{(a+x)^2} \end{aligned} \quad \dots(3)$$

$\therefore$  L.H.S. = R.H.S. using (2) and (3).

12. Find  $\rho$  at any point on  $x = a(\theta + \sin\theta)$  and  $y = a(1 - \cos\theta)$ .

**Solution.** Here  $x = a(\theta + \sin\theta)$ ,  $y = a(1 - \cos\theta)$

Differentiating w.r.t.  $\theta$

$$\frac{dx}{d\theta} = a(1 + \cos\theta), \quad \frac{dy}{d\theta} = a \sin\theta$$

$$y_1 = \frac{dy}{dx} = \frac{\frac{dy}{d\theta}}{\frac{dx}{d\theta}} = \frac{a \sin\theta}{a(1 + \cos\theta)}$$

$$= \frac{2 \sin \frac{\theta}{2} \cos \frac{\theta}{2}}{2 \cos^2 \frac{\theta}{2}}$$

$$y_1 = \tan \frac{\theta}{2}$$

Again differentiating w.r.t.  $\theta$

$$\begin{aligned} y_2 &= \frac{d}{dx} \left( \tan \frac{\theta}{2} \right) \\ &= \frac{d}{d\theta} \left( \tan \frac{\theta}{2} \right) \times \frac{d\theta}{dx} \\ &= \sec^2 \left( \frac{\theta}{2} \right) \times \frac{1}{2} \times \frac{1}{a(1 + \cos\theta)} \end{aligned}$$

$$= \frac{\sec^2 \frac{\theta}{2}}{2a \times 2 \cos^2 \frac{\theta}{2}}$$

$$y_2 = \frac{1}{4a \cos^4 \frac{\theta}{2}}$$

$$\rho = \frac{\{1 + y_1^2\}^{\frac{3}{2}}}{y_2}$$

$$= \frac{\left\{ 1 + \tan^2 \frac{\theta}{2} \right\}^{\frac{3}{2}}}{\left\{ \frac{1}{4a \cos^4 \frac{\theta}{2}} \right\}}$$

$$\begin{aligned}
&= \left\{ \sec^2 \left( \frac{\theta}{2} \right) \right\}^{\frac{3}{2}} \times 4a \cos^4 \left( \frac{\theta}{2} \right) \\
&= \frac{1}{\cos^3 \left( \frac{\theta}{2} \right)} \times 4a \cos^4 \left( \frac{\theta}{2} \right) \\
\rho &= 4a \cos \left( \frac{\theta}{2} \right).
\end{aligned}$$

**13.** Find the radius of curvature at the point ' $\theta$ ' on the curve  $x = a \log \sec \theta$ ,  $y = a (\tan \theta - \theta)$ .

**Solution**

$$x = a \log \sec \theta, \quad y = a (\tan \theta - \theta)$$

Differentiating w.r.t.  $\theta$

$$\begin{aligned}
\frac{dx}{d\theta} &= a \frac{1}{\sec \theta} \cdot \sec \theta \cdot \tan \theta, & \frac{dy}{d\theta} &= a (\sec^2 \theta - 1) \\
&= a \tan \theta & &= a \tan^2 \theta
\end{aligned}$$

$$\begin{aligned}
\therefore y_1 &= \frac{dy}{dx} = \frac{\frac{dy}{d\theta}}{\frac{dx}{d\theta}} \\
&= \frac{a \tan^2 \theta}{a \tan \theta} \\
y_1 &= \tan \theta \\
y_2 &= \frac{d^2 y}{dx^2} = \frac{d}{dx} (\tan \theta) \\
&= \frac{d}{d\theta} (\tan \theta) \cdot \frac{d\theta}{dx} \\
&= \sec^2 \theta \times \frac{1}{a \tan \theta} \\
&= \frac{\sec^2 \theta}{a \tan \theta}
\end{aligned}$$

Now,

$$\begin{aligned}
\rho &= \frac{\{1 + y_1^2\}^{\frac{3}{2}}}{y_2} \\
&= \frac{(1 + \tan^2 \theta)^{\frac{3}{2}}}{\left( \frac{\sec^2 \theta}{\tan \theta} \right)}
\end{aligned}$$



$$= \frac{\sec^3 \theta}{\sec^2 \theta} \times a \tan \theta$$

$$\rho = a \sec \theta \tan \theta.$$

**14.** For the curve  $x = a (\cos \theta + \theta \sin \theta)$ ,  $y = a (\sin \theta - \theta \cos \theta)$ , show that the radius of curvature at ' $\theta$ ' varies as  $\theta$ .

**Solution**

$$x = a (\cos \theta + \theta \sin \theta)$$

$$\Rightarrow \frac{dx}{d\theta} = a (-\sin \theta + \theta \cos \theta + \sin \theta) = a \theta \cos \theta$$

$$y = a (\sin \theta - \theta \cos \theta)$$

$$\Rightarrow \frac{dy}{d\theta} = a (\cos \theta + \theta \sin \theta - \cos \theta) = a \theta \sin \theta$$

$$y_1 = \frac{dy}{dx} = \frac{a \theta \sin \theta}{a \theta \cos \theta} = \tan \theta$$

$$y_2 = \frac{d}{dx} \left( \frac{dy}{dx} \right) = \frac{d}{dx} (\tan \theta)$$

$$= \frac{d}{d\theta} (\tan \theta) \cdot \frac{d\theta}{dx}$$

$$= \sec^2 \theta \times \frac{1}{a \theta \cos \theta}$$

$$= \frac{1}{a \theta \cos^3 \theta}$$

Now,

$$\rho = \frac{(1 + y_1^2)^{\frac{3}{2}}}{y_2}$$

$$= \frac{(1 + \tan^2 \theta)^{\frac{3}{2}}}{\left( \frac{1}{a \theta \cos^3 \theta} \right)}$$

$$= \sec^3 \theta \times a \theta \cos^3 \theta$$

$$= a \theta$$

i.e.,  $\rho \propto \theta$ .

**15.** If  $\rho_1$  and  $\rho_2$  are the radii of curvatures at the extremities of a focal chord of the parabola

$$y^2 = 4ax, \text{ then show that } \rho_1^{-\frac{2}{3}} + \rho_2^{-\frac{2}{3}} = (2a)^{-\frac{2}{3}}.$$

**Solution.** If  $(at_1^2, 2at_1)$  and  $(at_2^2, 2at_2)$  are the extremities of a focal chord of the parabola  $y^2 = 4ax$ .

Then  $t_1 \cdot t_2 = -1$

The parametric equations to the parabola are

$$\begin{aligned}x &= at^2, & y &= 2at \\x' &= 2at & y' &= 2a \\x'' &= 2a & y'' &= 0\end{aligned}$$

$$\begin{aligned}\therefore \rho &= \frac{\{x'^2 + y'^2\}^{\frac{3}{2}}}{x'y'' - x''y'} \\&= \frac{\{(2at)^2 + (2a)^2\}^{\frac{3}{2}}}{(-4a^2)} \\&= -\frac{8a^3(1+t^2)^{\frac{3}{2}}}{4a^2} \\ \rho &= -2a(1+t^2)^{\frac{3}{2}} \\ \rho^{\frac{-2}{3}} &= (2a)^{\frac{-2}{3}}(1+t^2)^{-1} \\ \rho^{\frac{-2}{3}} &= \frac{1}{(2a)^{\frac{2}{3}}} \times \frac{1}{(1+t^2)}\end{aligned}$$

Let  $t_1$  and  $t_2$  be extremities of a focal chord. Then  $t_2 = -\frac{1}{t_1}$ .

$$\text{Now, } \rho_1^{\frac{-2}{3}} = \rho_{t=t_1}^{\frac{-2}{3}} = \frac{1}{(2a)^{\frac{2}{3}}} \times \frac{1}{(1+t_1^2)}$$

$$\begin{aligned}\rho_2^{\frac{-2}{3}} &= \rho_{t=-\frac{1}{t_1}}^{\frac{-2}{3}} = \frac{1}{(2a)^{\frac{2}{3}}} \times \frac{1}{(1+t_1^2)} \\&= \frac{1}{(2a)^{\frac{2}{3}}} \times \frac{t_1^2}{(1+t_1^2)}\end{aligned}$$

$$\begin{aligned}\text{Adding } \rho_1^{\frac{-2}{3}} + \rho_2^{\frac{-2}{3}} &= \frac{1}{(2a)^{\frac{2}{3}}} \left\{ \frac{1}{1+t_1^2} + \frac{t_1^2}{1+t_1^2} \right\} \\&= (2a)^{\frac{-2}{3}} \times \frac{(1+t_1^2)}{(1+t_1^2)}\end{aligned}$$

$$\text{i.e., } \rho_1^{\frac{-2}{3}} + \rho_2^{\frac{-2}{3}} = (2a)^{\frac{-2}{3}}. \quad \text{Hence proved.}$$

### EXERCISE 1.1

1. Find  $\rho$  at any point on  $y = \log \sin x$ . [Ans. cosec  $x$ ]
2. Find  $\rho$  at  $x = 1$  on  $y = \frac{\log x}{x}$ . [Ans.  $\frac{3}{2\sqrt{2}}$ ]
3. Find the radius of curvature at  $x = \frac{\pi}{4}$  on  $y = \log \tan \left(\frac{x}{2}\right)$ . [Ans.  $2 \times \left(\frac{3}{2}\right)^{\frac{3}{2}}$ ]
4. Find the radius of curvature of  $(3, 4)$  on  $\frac{x^2}{9} + \frac{y^2}{16} = 2$ . [Ans.  $\frac{125}{12}$ ]
5. Find the radius of curvature at  $(x_1, y_1)$  on  $b^2x^2 - a^2y^2 = a^2b^2$ . [Ans.  $\frac{(b^2x_1^2 + a^4y_1^2)^{\frac{3}{2}}}{a^4b^4}$ ]
6. Find  $\rho$  at  $(4, 2)$  on  $y^2 = 4(x - 3)$ . [Ans.  $4\sqrt{2}$ ]
7. Show that  $\rho$  at any point on  $2xy = a^2$  is  $\frac{(4x^4 + a^4)^{\frac{3}{2}}}{8a^2x^3}$ .
8. Show that  $\rho$  at  $(0, 0)$  on  $y^2 = 12x$  is 6.
9. Find radius of curvature at  $x = 2$  on  $y^2 = \frac{x(x-2)}{x-5}$ . [Ans.  $\frac{1}{3}$ ]
10. Find  $\rho$  at  $(a, a)$  on  $x^3 + y^3 = 2a^3$ . [Ans.  $\frac{a}{\sqrt{2}}$ ]
11. Find the radius of curvature at  $(a, 2a)$  on  $x^2y = a(x^2 + a^2)$ . [Ans.  $\frac{5\sqrt{5}a}{6}$ ]
12. Find the radius of curvature at  $(-2a, 2a)$  on  $x^2y = a(x^2 + y^2)$ . [Ans.  $2a$ ]
13. Show that  $\rho$  at  $(a \cos^3\theta, a \sin^3\theta)$  on  $x^{\frac{2}{3}} + y^{\frac{2}{3}} = a^{\frac{2}{3}}$  is  $3a \sin \theta \cos \theta$ .
14. Find radius of curvature at  $\theta = \frac{\pi}{3}$  on  $x = a \sin \theta, y = b \cos 2\theta$ . [Ans.  $\frac{(a^2 + 12b^2)^{\frac{3}{2}}}{4ab}$ ]
15. Find  $\rho$  for  $x = t - \sin ht \cos ht, y = 2 \cos ht$ . [Ans.  $2 \cos h^2t \sin ht$ ]

### 1.2.3 Radius of Curvature in Pedal Form

Let polar form of the equation of a curve be  $r = f(\theta)$  and  $P(r, \theta)$  be a given point on it. Let the tangent to the curve at  $P$  subtend an angle  $\psi$  with the initial side. If the angle between the radius vector  $OP$  and the tangent at  $P$  is  $\phi$  then we have  $\psi = \theta + \phi$  (see figure).

Let  $p$  denote the length of the perpendicular from the pole  $O$  to the tangent at  $P$ . Then from the figure,

$$\sin \phi = \frac{OM}{OP} = \frac{p}{r}$$

Hence,  $p = r \sin \phi$  ... (1)

$$\therefore \frac{1}{\rho} = \frac{d\psi}{ds} = \frac{d\theta}{ds} + \frac{d\phi}{ds} = \frac{d\theta}{ds} + \frac{d\phi}{dr} \cdot \frac{dr}{ds} \quad \dots (2)$$

We know that  $\tan \phi = r \cdot \frac{d\theta}{dr}$

i.e.,  $\frac{\sin \phi}{\cos \phi} = \frac{r \cdot \frac{d\theta}{ds}}{\frac{dr}{ds}}$

Hence,  $\sin \phi = r \cdot \frac{d\theta}{ds}$

and  $\cos \phi = \frac{dr}{ds}$

From (2), 
$$\begin{aligned} \frac{1}{\rho} &= \frac{\sin \phi}{r} + \cos \phi \cdot \frac{d\phi}{dr} \\ &= \frac{1}{r} \left[ \sin \phi + r \cos \phi \cdot \frac{d\phi}{dr} \right] \\ &= \frac{1}{r} \cdot \frac{d}{dr} (r \sin \phi) \end{aligned}$$

Since,  $r \sin \phi = p$

Therefore,  $\rho = r \cdot \frac{dr}{dp}$  ... (3)

This is the Pedal form of the radius of curvature.

### 1.2.4 Radius of Curvature in Polar Form

Let  $r = f(\theta)$  be the equation of a curve in the polar form and  $p(r, \theta)$  be a point on it. Then we know that

Differentiating w.r.t.  $r$ , we get  $\frac{1}{p^2} = \frac{1}{r^2} + \frac{1}{r^4} \left( \frac{dr}{d\theta} \right)^2$  ... (4)

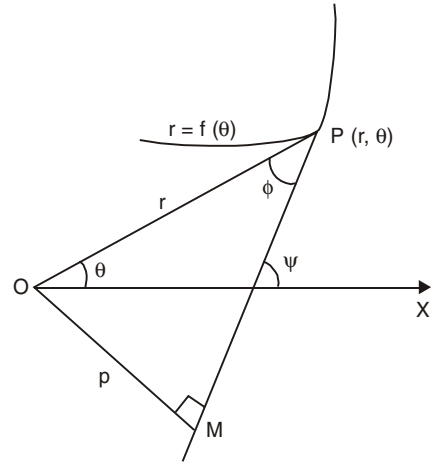

Fig. 1.2

$$\begin{aligned}
\frac{-2}{p^3} \cdot \frac{dp}{dr} &= \frac{-2}{r^3} + \left(\frac{dr}{d\theta}\right)^2 (-4r^{-5}) + \frac{1}{r^4} \cdot 2 \cdot \frac{dr}{d\theta} \cdot \frac{d}{dr} \left(\frac{dr}{d\theta}\right) \\
&= \frac{-2}{r^3} - \frac{4}{r^5} \cdot \left(\frac{dr}{d\theta}\right)^2 + \frac{2}{r^4} \cdot \frac{dr}{d\theta} \cdot \frac{d^2r}{d\theta^2} \cdot \frac{d\theta}{dr} \\
&= \frac{-2}{r^3} - \frac{4}{r^5} \left(\frac{dr}{d\theta}\right)^2 + \frac{2}{r^4} \cdot \frac{d^2r}{d\theta^2}
\end{aligned}$$

Hence,

$$\frac{dp}{dr} = p^3 \left[ \frac{1}{r^3} + \frac{2}{r^5} \left(\frac{dr}{d\theta}\right)^2 - \frac{1}{r^4} \frac{d^2r}{d\theta^2} \right]$$

Now,

$$\begin{aligned}
\rho &= r \cdot \frac{dr}{dp} = \frac{r}{p^3 \left\{ \frac{1}{r^3} + \frac{2}{r^5} \left(\frac{dr}{d\theta}\right)^2 - \frac{1}{r^4} \frac{d^2r}{d\theta^2} \right\}} \\
&= \frac{r^6 \cdot \frac{1}{p^3}}{r^2 + 2 \left(\frac{dr}{d\theta}\right)^2 - r \cdot \frac{d^2r}{d\theta^2}}
\end{aligned}$$

By using equation (4),

$$\begin{aligned}
&\frac{r^6 \cdot \left\{ \frac{1}{r^2} + \frac{1}{r^4} \left(\frac{dr}{d\theta}\right)^2 \right\}^{\frac{3}{2}}}{r^2 + 2 \left(\frac{dr}{d\theta}\right)^2 - r \cdot \frac{d^2r}{d\theta^2}} \\
\rho &= \frac{\left\{ r^2 + \left(\frac{dr}{d\theta}\right)^2 \right\}^{\frac{3}{2}}}{r^2 + 2 \left(\frac{dr}{d\theta}\right)^2 - r \cdot \frac{d^2r}{d\theta^2}} \quad \dots(5)
\end{aligned}$$

where

$$r_1 = \frac{dr}{d\theta}, \quad r_2 = \frac{d^2r}{d\theta^2}.$$

$\therefore$

$$\rho = \frac{\left\{ r^2 + r_1^2 \right\}^{\frac{3}{2}}}{r^2 + 2r_1^2 - r r_2}$$

This is the formula for the radius of curvature in the polar form.

### WORKED OUT EXAMPLES

1. Find the radius of the curvature of each of the following curves:

(i)  $r^3 = 2ap^2$  (Cardioid)

(ii)  $p^2 = ar$

(iii)  $\frac{1}{p^2} = \frac{1}{a^2} + \frac{1}{b^2} - \frac{r^2}{a^2b^2}$  (Ellipse).

**Solution.** (i) Here  $r^3 = 2ap^2$

Differentiating w.r.t.  $p$ , we get

$$3r^2 \cdot \frac{dr}{dp} = 4ap$$

$$\Rightarrow \frac{dr}{dp} = \frac{4ap}{3r^2}$$

Hence, 
$$\rho = r \cdot \frac{dr}{dp} = r \cdot \frac{4ap}{3r^2} = \frac{4ap}{3r}$$

where  $p = \left(\frac{r^3}{2a}\right)^{\frac{1}{2}}$

$$\begin{aligned} \rho &= \frac{4a \cdot \left(\frac{r^3}{2a}\right)^{\frac{1}{2}}}{3r} \\ &= \frac{4a r^{\frac{3}{2}}}{3r\sqrt{2a}} = \frac{2\sqrt{2ar}}{3} \end{aligned}$$

(ii) Here  $p^2 = ar$

Differentiating w.r.t.  $p$ , we get

Then 
$$2p = a \cdot \frac{dr}{dp}$$

$$\Rightarrow \frac{dr}{dp} = \frac{2p}{a}$$

where  $p = \sqrt{ar}$

$$\rho = r \frac{dr}{dp} = r \cdot \frac{2 \cdot \sqrt{ar}}{a} = \frac{2r^{\frac{3}{2}}}{\sqrt{a}}$$

(iii) Given 
$$\frac{1}{p^2} = \frac{1}{a^2} + \frac{1}{b^2} - \frac{r^2}{a^2b^2}$$

Differentiating w.r.t.  $p$ , we get

$$\frac{-2}{p^3} = \frac{-1}{a^2b^2} 2r \cdot \frac{dr}{dp}$$

Hence 
$$\frac{dr}{dp} = \frac{a^2 b^2}{p^3 r}$$

Therefore, 
$$\rho = r \cdot \frac{dr}{dp} = r \cdot \frac{a^2 b^2}{p^3 r} = \frac{a^2 b^2}{p^3}$$

2. Find the radius of curvature of the cardioid  $r = a(1 + \cos \theta)$  at any point  $(r, \theta)$  on it. Also prove that  $\frac{\rho^2}{r}$  is a constant.

**Solution.** Given  $r = a(1 + \cos \theta)$

Differentiating w.r.t.  $\theta$

$$r_1 = \frac{dr}{d\theta} = -a \sin \theta$$

and 
$$r_2 = \frac{d^2 r}{d\theta^2} = -a \cos \theta$$

$\therefore$  The radius of curvature in the polar form

$$\begin{aligned} \rho &= \frac{\{r^2 + r_1^2\}^{\frac{3}{2}}}{r^2 + 2r_1^2 - r r_2} \\ &= \frac{\{a^2(1 + \cos \theta)^2 + a^2 \sin^2 \theta\}^{\frac{3}{2}}}{a^2(1 + \cos \theta)^2 + 2a^2 \sin^2 \theta - a(1 + \cos \theta)(-a \cos \theta)} \\ &= \frac{a^3 \{1 + 2 \cos \theta + \cos^2 \theta + \sin^2 \theta\}^{\frac{3}{2}}}{a^2 \{1 + 2 \cos \theta + \cos^2 \theta + 2 \sin^2 \theta + \cos \theta + \cos^2 \theta\}} \\ &= \frac{a \{2(1 + \cos \theta)\}^{\frac{3}{2}}}{3(1 + \cos \theta)} \\ &= \frac{2\sqrt{2} a (1 + \cos \theta)^{\frac{1}{2}}}{3} \\ &= \frac{2\sqrt{2} a \left(2 \cos^2 \frac{\theta}{2}\right)^{\frac{1}{2}}}{3} \\ \rho &= \frac{4}{3} a \cos \frac{\theta}{2} \end{aligned}$$

Squaring on both sides, we get

$$\begin{aligned} \rho^2 &= \frac{16}{9} a^2 \cos^2 \frac{\theta}{2} && \left[ \text{where } \cos^2 \frac{\theta}{2} = \frac{1}{2}(1 + \cos \theta) \right] \\ &= \frac{8a^2}{9} (1 + \cos \theta) && \left[ \text{where } 1 + \cos \theta = \frac{r}{a} \right] \end{aligned}$$

$$\rho^2 = \frac{8a^2}{9} \cdot \frac{r}{a} = \frac{8ar}{9}$$

Hence,  $\frac{\rho^2}{r} = \frac{8a}{9}$  which is constant.

3. Show that for the curve  $r^n = a^n \cos n\theta$  the radius of curvature is  $\frac{a^n}{(n+1)r^{n-1}}$ .

**Solution.** Here  $r^n = a^n \cos n\theta$

Taking logarithms on both sides, we get

$$n \log r = n \log a + \log \cos n\theta$$

Differentiating w.r.t.  $\theta$ , we have

$$\frac{n}{r} \frac{dr}{d\theta} = 0 - \frac{n \sin n\theta}{\cos n\theta}$$

$$r_1 = \frac{dr}{d\theta} = -r \tan n\theta$$

Differentiating w.r.t.  $\theta$  again, we obtain

$$\begin{aligned} r_2 = \frac{d^2r}{d\theta^2} &= - \left\{ rn \sec^2 n\theta + \tan n\theta \cdot \frac{dr}{d\theta} \right\} \\ &= - \left\{ nr \sec^2 n\theta - r \tan^2 n\theta \right\} \\ &= r \tan^2 n\theta - nr \sec^2 n\theta \end{aligned}$$

Using the polar form of  $\rho$ , we get

$$\begin{aligned} \rho &= \frac{\{r^2 + r_1^2\}^{\frac{3}{2}}}{r^2 + 2r_1^2 - rr_2} \\ &= \frac{\{r^2 + r^2 \tan^2 n\theta\}^{\frac{3}{2}}}{r^2 + 2(-r \tan n\theta)^2 - r(r \tan^2 n\theta - nr \sec^2 n\theta)} \\ &= \frac{r^3 \sec^3 n\theta}{r^2 [1 + 2 \tan^2 n\theta - \tan^2 n\theta + n \sec^2 n\theta]} \\ &= \frac{r \sec^3 n\theta}{(n+1) \sec^2 n\theta} \\ &= \frac{r}{(n+1) \cos n\theta} \\ &= \frac{r}{(n+1) \left(\frac{r^n}{a^n}\right)} \quad \left[ \text{where } \cos n\theta = \frac{r^n}{a^n} \right] \\ &= \frac{a^n}{(n+1) r^{n-1}}. \end{aligned}$$



4. Find the radii of curvature of the following curves:

$$(i) r = ae^{\theta \cot \alpha}$$

$$(ii) r(1 + \cos \theta) = a$$

$$(iii) \theta = \frac{\sqrt{r^2 - a^2}}{a} - \cos^{-1} \left( \frac{a}{r} \right).$$

**Solution.** (i) Here  $r = ae^{\theta \cot \alpha}$

Differentiating w.r.t  $\theta$

$$\begin{aligned} \frac{dr}{d\theta} &= ae^{\theta \cot \alpha} \cdot \cot \alpha \\ &= r \cdot \cot \alpha \end{aligned}$$

So that,  $\tan \phi = \frac{r}{\frac{dr}{d\theta}}$

$$= \frac{r}{r \cot \alpha} = \tan \alpha$$

Hence,  $\phi = \alpha$ , since  $p = r \sin \phi$

We get,  $p = r \sin \alpha$ .

This is the Pedal equation of the given curve. From which, we get

$$\frac{dr}{dp} = \frac{1}{\sin \alpha}$$

Hence,  $p = r \cdot \frac{dr}{dp} = r \operatorname{cosec} \alpha$ .

(ii) Given equation of the curve is

$$r(1 + \cos \theta) = a$$

Differentiating w.r.t.  $\theta$ , we get

$$r(-\sin \theta) + (1 + \cos \theta) \cdot \frac{dr}{d\theta} = 0$$

or  $\frac{dr}{d\theta} = \frac{r \sin \theta}{1 + \cos \theta}$

We have,  $\frac{1}{p^2} = \frac{1}{r^2} + \frac{1}{r^4} \left( \frac{dr}{d\theta} \right)^2$

$$= \frac{1}{r^2} + \frac{1}{r^4} \cdot \frac{r^2 \sin^2 \theta}{(1 + \cos \theta)^2}$$

$$= \frac{1}{r^2} \left[ 1 + \frac{\sin^2 \theta}{(1 + \cos \theta)^2} \right]$$

$$= \frac{1}{r^2} \left[ \frac{(1 + \cos \theta)^2 + \sin^2 \theta}{(1 + \cos \theta)^2} \right]$$

$$= \frac{1}{r^2} \left[ \frac{2(1 + \cos \theta)}{(1 + \cos \theta)^2} \right]$$

$$= \frac{2}{r^2 (1 + \cos \theta)}$$

where  $1 + \cos \theta = \frac{a}{r}$

$$\frac{1}{p^2} = \frac{2}{r^2 \cdot \frac{a}{r}} = \frac{2}{ar}$$

Hence,  $p^2 = \frac{ar}{2}$  which is the pedal equation of the curve.

Differentiating w.r.t.  $p$ , we get

$$2p = \frac{a}{2} \cdot \frac{dr}{dp}$$

$$\Rightarrow \frac{dr}{dp} = \frac{4p}{a}$$

$$\therefore \rho = r \cdot \frac{dr}{dp}$$

$$= r \cdot \frac{4p}{a} \text{ where } p = \sqrt{\frac{ar}{2}}$$

$$= r \cdot \frac{4}{a} \frac{\sqrt{ar}}{\sqrt{2}}$$

$$= 2\sqrt{2} \sqrt{a} r^{\frac{3}{2}}.$$

(iii) Here,  $\theta = \frac{\sqrt{r^2 - a^2}}{a} - \cos^{-1} \left( \frac{a}{r} \right)$

Then,  $\frac{d\theta}{dr} = \frac{2r}{a \cdot 2 \cdot \sqrt{r^2 - a^2}} + \frac{1}{\left(1 - \frac{a^2}{r^2}\right)^{\frac{1}{2}}} \left( \frac{-a}{r} \right)$

$$= \frac{r}{a\sqrt{r^2 - a^2}} - \frac{a}{r\sqrt{r^2 - a^2}}$$

$$= \frac{r^2 - a^2}{ar\sqrt{r^2 - a^2}}$$

$$\frac{d\theta}{dr} = \sqrt{\frac{r^2 - a^2}{ar}}$$

so that

$$\frac{dr}{d\theta} = \frac{ar}{\sqrt{r^2 - a^2}}$$

We have the Pedal equation, we get

$$\begin{aligned} \frac{1}{p^2} &= \frac{1}{r^2} + \frac{1}{r^4} \left( \frac{dr}{d\theta} \right)^2 \\ &= \frac{1}{r^2} + \frac{1}{r^4} \cdot \frac{a^2 r^2}{(r^2 - a^2)} \\ &= \frac{1}{r^2} \left\{ 1 + \frac{a^2}{r^2 - a^2} \right\} \end{aligned}$$

$$\frac{1}{p^2} = \frac{1}{r^2 - a^2}$$

Hence

$$p^2 = r^2 - a^2$$

From this we get

$$\frac{dr}{dp} = \frac{p}{r}$$

$$\therefore \rho = r \cdot \frac{p}{r} = p = \sqrt{r^2 - a^2}.$$

## EXERCISE 1.2

1. Find the radius curvature at the point  $(p, r)$  on each of the following curves:

(i)  $pr = a^2$  (Hyperbola)  $\left[ \text{Ans. } \frac{r^3}{a^2} \right]$

(ii)  $r^3 = a^2 p$  (Lemniscate)  $\left[ \text{Ans. } \frac{a^2}{3r} \right]$

(iii)  $pa^n = r^{n+1}$  (Sine spiral)  $\left[ \text{Ans. } \frac{a^n}{(n+1)r^{n-1}} \right]$

(iv)  $p = \frac{r^4}{r^2 + a^2}$  (Archimedian spiral)  $\left[ \text{Ans. } \frac{(a^2 + r^2)^{\frac{3}{2}}}{r^2 + 2a^2} \right]$

2. Find the radius of curvature at  $(r, \theta)$  on each of the following curves:

$$(i) r = \frac{a}{\theta} \quad \left[ \text{Ans. } \frac{r(a^2 + r^2)^{\frac{3}{2}}}{a^3} \right] \quad (ii) r = a \cos \theta \quad \left[ \text{Ans. } \frac{a}{2} \right]$$

$$(iii) r^2 = a^2 \cos 2\theta \quad \left[ \text{Ans. } \frac{a^2}{3r} \right] \quad (iv) r^n = a^n \sin n\theta \quad \left[ \text{Ans. } \frac{a^n}{(n+1)r^{n-1}} \right]$$

$$(v) r^2 \cos 2\theta = a^2 \quad \left[ \text{Ans. } \frac{r^3}{a^2} \right] \quad (vi) r = \frac{a}{2}(1 - \cos \theta) \quad \left[ \text{Ans. } \frac{2\sqrt{ar}}{3} \right]$$

$$(vii) r = a \sec 2\theta \quad \left[ \text{Ans. } \frac{r^4}{3p^2} \right] \quad (viii) r = a \sin n\theta \quad \left[ \text{Ans. } \frac{na}{2} \right]$$

3. If  $\rho_1$  and  $\rho_2$  are the radii of curvature at the extremities of any chord of the cardioid

$$r = a(1 + \cos \theta) \text{ which passes through the pole. Prove that } \rho_1^2 + \rho_2^2 = \frac{16a^2}{9}.$$

## 1.3 SOME FUNDAMENTAL THEOREM

### 1.3.1 Rolle's Theorem

If a function  $f(x)$  is

1. continuous in a closed interval  $[a, b]$ ,
2. differentiable in the open interval  $(a, b)$  and
3.  $f(a) = f(b)$ .

Then there exists at least one value  $c$  of  $x$  in  $(a, b)$  such that  $f'(c) = 0$

(No proof).

### 1.3.2 Lagrange's Mean Value Theorem

Suppose a function  $f(x)$  satisfies the following two conditions.

1.  $f(x)$  is continuous in the closed interval  $[a, b]$ .
2.  $f(x)$  is differentiable in the open interval  $(a, b)$ .

Then there exists at least one value  $c$  of  $x$  in the open interval  $(a, b)$ , such that

$$\frac{f(b) - f(a)}{b - a} = f'(c)$$

**Proof.** Let us define a new function

$$\phi(x) = f(x) - kx \quad \dots(1)$$

where  $k$  is a constant. Since  $f(x)$ ,  $kx$  and  $\phi(x)$  is continuous in  $[a, b]$ , differentiable in  $(a, b)$ .

From (1) we have,  $\phi(a) = f(a) - k \cdot a$

$$\phi(b) = f(b) - k \cdot b$$

$\therefore \phi(a) = \phi(b)$  holds good if

$$f(a) - k \cdot a = f(b) - k \cdot b$$

*i.e.*,  $k(b - a) = f(b) - f(a)$

or 
$$k = \frac{f(b) - f(a)}{b - a} \quad \dots(2)$$

Hence, if  $k$  is chosen as given by (2), then  $\phi(x)$  satisfy all the conditions of Rolle's theorem. Therefore, by Rolle's theorem there exists at least one point  $c$  in  $(a, b)$  such that  $\phi'(c) = 0$ .

Differentiating (1) w.r.t.  $x$  we have,

$$\phi'(x) = f'(x) - k$$

and  $\phi'(c) = 0$  gives  $f'(c) - k = 0$

*i.e.*,  $k = f'(c) \quad \dots(3)$

Equating the R.H.S. of (2) and (3) we have

$$\frac{f(b) - f(a)}{b - a} = f'(c) \quad \dots(4)$$

This proves Lagrange's mean value theorem.

### 1.3.3 Cauchy's Mean Value Theorem

If two functions  $f(x)$  and  $g(x)$  are such that

1.  $f(x)$  and  $g(x)$  are continuous in the closed interval  $[a, b]$ .
2.  $f(x)$  and  $g(x)$  are differentiable in the open interval  $(a, b)$ .
3.  $g'(x) \neq 0$  for all  $x \in (a, b)$ .

Then there exists at least one value  $c \in (a, b)$  such that

$$\frac{f(b) - f(a)}{g(b) - g(a)} = \frac{f'(c)}{g'(c)}$$

**Proof:** Let us define a new function

$$\phi(x) = f(x) - kg(x) \quad \dots(1)$$

where  $k$  is a constant. From the given conditions it is evident that  $\phi(x)$  is also continuous in  $[a, b]$ , differentiable in  $(a, b)$ .

Further (1), we have

$$\phi(a) = f(a) - k g(a); \quad \phi(b) = f(b) - k g(b)$$

$\therefore \phi(a) = \phi(b)$  holds good if

$$f(a) - k g(a) = f(b) - k g(b)$$

*i.e.*,  $k[g(b) - g(a)] = f(b) - f(a)$

or 
$$k = \frac{f(b) - f(a)}{g(b) - g(a)} \quad \dots(2)$$

Here,  $g(b) \neq g(a)$ . Because if  $g(b) = g(a)$  then  $g(x)$  would satisfy all the conditions Rolle's theorem at least one point  $c$  in  $(a, b)$  such that  $g'(c) = 0$ . This contradicts the data that  $g'(x) \neq 0$  for all  $x$  in  $(a, b)$ . Hence if  $k$  is chosen as given by (2) then  $\phi(x)$  satisfy all the conditions of Rolle's theorem.

Therefore by Rolle's theorem there exists at least one value  $c$  in  $(a, b)$  such that  $\phi'(c) = 0$ .

Differentiating (1) w.r.t.  $x$  we have,

$$\phi'(x) = f'(x) - kg'(x) \quad \text{and} \quad \phi'(c) = 0$$

gives  $f'(c) - kg'(c) = 0$

*i.e.*,  $f'(c) = kg'(c)$

Thus, 
$$k = \frac{f'(c)}{g'(c)} \quad \dots(3)$$

Equating the R.H.S. of (2) and (3) we have

$$\frac{f(b) - f(a)}{g(b) - g(a)} = \frac{f'(c)}{g'(c)}$$

This proves mean value theorem.

### 1.3.4 Taylor's Theorem

Taylor's Theorem for a function of a single variable and Maclaurin's series function:

Suppose a function  $f(x)$  satisfies the following conditions:

(1)  $f(x), f'(x), f''(x), \dots, f^{(n-1)}(x)$  are continuous in the closed interval  $[a, b]$ .

(2)  $f^{(n-1)}(x)$  is differentiable *i.e.*,  $f^{(n)}(x)$  exists in the open interval  $(a, b)$ .

Then there exists a point  $c \in (a, b)$  such that

$$f(b) = f(a) + (b-a)f'(a) + \frac{(b-a)^2}{2!} f''(a) + \dots + \frac{(b-a)^{n-1}}{(n-1)!} f^{(n-1)}(a) + R_n$$

where  $R_n = \frac{(b-a)^n}{n!} f^n(c) \quad \dots(1)$

Taylor's theorem is more usually written in the following forms. Substitute  $b = x$  in (1)

$$f(x) = f(a) + (x-a)f'(a) + \frac{(x-a)^2}{2!} f''(a) + \frac{(x-a)^3}{3!} + \dots + \frac{x^{n-1}}{(n-1)!} f^{(n-1)}(a) + R_n(x) + \dots \quad \dots(2)$$

where  $R_n(x) = \frac{(x-a)^n}{n!} f^{(n)}(x)$ .

Thus  $f(x)$  can be expressed as the sum of an infinite series. This series is called the Taylor's series for the function  $f(x)$  about the point  $a$ .

If we substitute  $a = 0$ , in Eqn. (2), we get

$$f(x) = f(0) + x f'(0) + \frac{x^2}{2!} f''(0) + \frac{x^3}{3!} f'''(0) + \dots + \frac{x^n}{n!} f^{(n)}(0) + \dots \quad \dots(3)$$

This is called the Maclaurin's series for the function  $f(x)$ .

If  $f(x) = y$  and  $f'(x), f''(x), \dots$

are denoted by  $y_1, y_2, \dots$  the Maclaurin's series can also be written in the form:

$$y = y(0) + x y_1(0) + \frac{x^2}{2!} y_2(0) + \dots + \frac{x^n}{n!} y_n(0) + \dots \quad \dots(4)$$

## WORKED OUT EXAMPLES

**1.** Verify Rolle's theorem for the function  $f(x) = x^2 - 4x + 8$  in the interval  $[1, 3]$ .

**Solution**

$f(x) = x^2 - 4x + 8$  is continuous in  $[1, 3]$  and

$f'(x) = 2x - 4$  exist for all values in  $(1, 3)$

$$\therefore f(1) = 1 - 4 + 8 = 5; f(3) = 3^2 - 4(3) + 8 = 5$$

$$\therefore f(1) = f(3)$$

Hence all the three conditions of the theorem are satisfied.

Now consider  $f'(c) = 0$

$$\text{i.e.,} \quad 2c - 4 = 0 \Rightarrow 2c = 4$$

$$c = \frac{4}{2} = 2 \in (1, 3)$$

and hence Rolle's theorem is verified.

**2.** Verify Rolle's theorem for the function

$$f(x) = x(x+3)e^{-x/2} \text{ in the interval } [-3, 0].$$

**Solution**

$$f(x) = x(x+3)e^{-x/2} \text{ is continuous in } [-3, 0]$$

and

$$\begin{aligned} f'(x) &= (x^2 + 3x) \left(-\frac{1}{2}\right) e^{-x/2} + (2x + 3)e^{-x/2} \\ &= -\frac{1}{2} (x^2 - x - 6)e^{-x/2} \end{aligned}$$

Therefore  $f'(x)$  exists (i.e., finite) for all  $x$

$$\text{Also} \quad f(-3) = 0, f(0) = 0$$

So that  $f(-3) = f(0)$

Hence all the three conditions of the theorem are satisfied.

Now consider  $f'(c) = 0$

$$\text{i.e., } \frac{-1}{2} (c^2 - c - 6)e^{-c/2} = 0$$

$$c^2 - c - 6 = 0$$

$$(c + 2)(c - 3) = 0$$

$$c = 3 \text{ or } -2$$

Hence there exists  $-2 \in (-3, 0)$  such that

$$f'(-2) = 0$$

and hence Rolle's theorem is verified.

**3. Verify Rolle's theorem for the function**

$f(x) = (x - a)^m (x - b)^n$  in  $[a, b]$  where  $m > 1$  and  $n > 1$ .

**Solution**  $f(x) = (x - a)^m (x - b)^n$  is continuous in  $[a, b]$

$$f'(x) = (x - a)^m \cdot n (x - b)^{n-1} + m (x - a)^{m-1} (x - b)^n$$

$$= (x - a)^{m-1} (x - b)^{n-1} [n(x - a) + m(x - b)]$$

$$f'(x) = (x - a)^{m-1} (x - b)^{n-1} [nx - na + mx - mb]$$

$$= (x - a)^{m-1} (x - b)^{n-1} [(m + n)x - (na + mb)] \quad \dots(1)$$

$f'(x)$  exists in  $(a, b)$

Also  $f(a) = 0 = f(b)$

Hence all the conditions of the theorem are satisfied.

Now consider  $f'(c) = 0$

From (1)  $(c - a)^{m-1} (c - b)^{n-1} [(m + n)c - (na + mb)] = 0$

$$\Rightarrow c - a = 0, c - b = 0, (m + n)c - (na + mb) = 0$$

$$\text{i.e., } c = a, c = b, c = \frac{na + mb}{m + n}$$

$a, b$  are the end points.

$c = \frac{na + mb}{m + n}$  is the  $x$ -coordinate of the point which divides the line joining  $[a, f(a)], [b, f(b)]$

internally in the ratio  $m : n$ .

$$\therefore c = \frac{na + mb}{m + n} \in (a, b)$$

Thus the Rolle's theorem is verified.



4. Verify Rolle's theorem for the following functions:

(i)  $\sin x$  in  $[-\pi, \pi]$

(ii)  $e^x \sin x$  in  $[0, \pi]$

(iii)  $\frac{\sin x}{e^x}$  in  $[0, \pi]$

(iv)  $e^x (\sin x - \cos x)$  in  $\left[\frac{\pi}{4}, \frac{5\pi}{4}\right]$

**Solution**

(i)  $f(x) = \sin x$  is continuous in  $[-\pi, \pi]$

$f'(x) = \cos x$  exists in  $[-\pi, \pi]$

and also

$f(-\pi) = \sin(-\pi) = 0$

$f(\pi) = \sin \pi = 0$

so that

$f(-\pi) = f(\pi)$

Thus  $f(x)$  satisfies all the conditions of the Rolle's theorem satisfied.

Now consider  $f'(c) = 0$

$\therefore \cos c = 0$  so that

$$c = \pm \frac{\pi}{2} \text{ Both these values}$$

lie in  $(-\pi, \pi)$ .

$\therefore c = \pm \frac{\pi}{2} \in (-\pi, \pi)$

Hence Rolle's theorem is verified.

(ii)  $f(x) = e^x \sin x$  is continuous in  $[0, \pi]$

$f'(x) = e^x \cos x + \sin x \cdot e^x$

$= e^x (\cos x + \sin x)$

$f'(x)$  exists in  $(0, \pi)$

And also  $f(0) = e^0 \sin(0) = 0$

$f(\pi) = e^\pi \sin(\pi) = 0$

$\therefore f(0) = f(\pi) = 0$

Therefore  $f(x)$  satisfies all the conditions of Rolle's theorem.

Now consider  $f'(c) = 0$

$e^c (\cos c + \sin c) = 0$

$\cos c + \sin c = 0$

$\sin c = -\cos c$  as  $e^c \neq 0$

or

$\tan c = -1$

$$c = \frac{-\pi}{4} \text{ or } c = \frac{3\pi}{4}$$

Hence there exists  $c = \frac{3\pi}{4} \in (0, \pi)$

Hence Rolle's theorem is verified.

$$\begin{aligned}
 \text{(iii)} \quad f(x) &= \frac{\sin x}{e^x} \text{ is continuous in } (0, \pi) \\
 f'(x) &= \frac{e^x (\cos x) - \sin x e^x}{e^{2x}} \\
 f'(x) &= \frac{\cos x - \sin x}{e^x} \quad \dots(1)
 \end{aligned}$$

$f'(x)$  exists in  $(0, \pi)$

$$\text{Also} \quad f(0) = \frac{\sin 0}{e^0} = 0$$

$$f(\pi) = \frac{\sin \pi}{e^\pi} = 0$$

$$f(0) \neq f(\pi) = 0$$

Hence all the conditions of the theorem are satisfied.

$$\text{Consider} \quad f'(c) = 0$$

$$\text{From (1),} \quad \frac{\cos c - \sin c}{e^c} = 0$$

$$\cos c - \sin c = 0$$

$$\sin c = \cos c$$

$$\tan c = 1$$

$$c = \frac{\pi}{4}$$

$$\text{Hence this exists} \quad c = \frac{\pi}{4} \in (0, \pi)$$

$\therefore$  Rolle's theorem is verified.

$$\text{(iv) Let } f(x) = e^x (\sin x - \cos x) \text{ is continuous in } \left[ \frac{\pi}{4}, \frac{5\pi}{4} \right]$$

$$f'(x) = e^x (\cos x + \sin x) + e^x (\sin x - \cos x)$$

$$f'(x) = 2e^x \sin x \quad \dots(1)$$

$$f(x) \text{ is differentiable in } \left( \frac{\pi}{4}, \frac{5\pi}{4} \right)$$

$$f\left(\frac{\pi}{4}\right) = e^{\pi/4} \left( \sin \frac{\pi}{4} - \cos \frac{\pi}{4} \right)$$

$$= e^{\pi/4} \left( \frac{1}{\sqrt{2}} - \frac{1}{\sqrt{2}} \right) = 0$$

$$f\left(\frac{5\pi}{4}\right) = e^{5\pi/4} \left( \sin \frac{5\pi}{4} - \cos \frac{5\pi}{4} \right)$$

$$= e^{5\pi/4} \left( -\frac{1}{\sqrt{2}} + \frac{1}{\sqrt{2}} \right) = 0$$

$$\therefore f\left(\frac{\pi}{4}\right) = f\left(\frac{5\pi}{4}\right) = 0$$

Hence all the conditions of the theorem are satisfied.

Now consider  $f'(c) = 0$

From (1), we have,  $2 e^c \sin c = 0$  ( $\because e^c \neq 0$ )

$$\begin{aligned} \therefore \sin c &= 0 = \sin n\pi \\ c &= n\pi \text{ where } n = 0, 1, 2, \dots \end{aligned}$$

$$\text{But } c = \pi \in \left( \frac{\pi}{4}, \frac{5\pi}{4} \right)$$

Thus Rolle's theorem is satisfied.

**5.** Show that the constant  $c$  of Rolle's theorem for the function  $f(x) = \log \left[ \frac{x^2 + ab}{(a+b)x} \right]$  in  $a \leq x \leq b$  where  $0 < a < b$  is the geometric mean of  $a$  and  $b$ .

**Solution.** The given  $f(x)$  is continuous in  $[a, b]$  since  $0 < a < b$

$$f(x) = \log \left[ \frac{x^2 + ab}{(a+b)x} \right]$$

The given function can be written in the form

$$\begin{aligned} f(x) &= \log(x^2 + ab) - \log(a+b) - \log x \\ f'(x) &= \frac{2x}{x^2 + ab} - 0 - \frac{1}{x} \\ &= \frac{2x^2 - (x^2 + ab)}{(x^2 + ab)x} = \frac{x^2 - ab}{(x^2 + ab)x} \quad \dots(1) \end{aligned}$$

$f'(x)$  exists in  $(a, b)$

$$\text{Also } f(a) = \log \left[ \frac{a^2 + ab}{(a+b)a} \right] = \log 1 = 0$$

$$f(b) = \log \left[ \frac{b^2 + ab}{(a+b)b} \right] = \log 1 = 0$$

$$\therefore f(a) = f(b) = 0$$

Hence all the conditions of the theorem are satisfied.

Now consider  $f'(c) = 0$

From (1), we have  $\frac{c^2 - ab}{(c^2 + ab)c} = 0$

$$c^2 - ab = 0$$

*i.e.*,  $c = \pm \sqrt{ab}$

$\therefore c = + \sqrt{ab} \in (a, b)$  and we know

that  $\sqrt{ab}$  is the geometric mean of  $a$  and  $b$ .

6. Verify Lagrange's mean value theorem for the following functions:

(i)  $f(x) = (x - 1)(x - 2)(x - 3)$  in  $[0, 4]$       (ii)  $f(x) = \sin^2 x$  in  $\left[0, \frac{\pi}{2}\right]$

(iii)  $f(x) = \log x$  in  $[1, e]$       (iv)  $f(x) = \sin^{-1} x$  in  $[0, 1]$ .

**Solution**

(i) We have the theorem  $\frac{f(b) - f(a)}{b - a} = f'(c)$

$f(x) = (x - 1)(x - 2)(x - 3)$  is continuous in  $[0, 4]$

$$a = 0, b = 4 \text{ by data}$$

$\therefore f(b) = f(4) = 3 \cdot 2 \cdot 1 = 6$  and

$$f(a) = f(0) = (-1)(-2)(-3) = -6$$

We have  $f(x) = x^3 - 6x^2 + 11x - 6$  in the simplified form.

$\therefore f'(x) = 3x^2 - 12x + 11$  exists in  $(0, 4)$

The theorem becomes,

$$\frac{f(4) - f(0)}{4 - 0} = 3c^2 - 11c + 11$$

$$\frac{6 - (-6)}{4} = 3c^2 - 11c + 11$$

or  $3c^2 - 11c + 8 = 0$

$\therefore c = \frac{11 \pm \sqrt{121 - 96}}{6}$

$$c = \frac{11 \pm \sqrt{25}}{6}$$

*i.e.*,  $c = \frac{11 + \sqrt{25}}{6}, \frac{11 - \sqrt{25}}{6}$

$$c = 3.15 \text{ and } 0.85 \text{ both belongs to } (0, 4)$$

$\therefore c = 3.15 \text{ and } 0.85 \in (0, 4)$

Thus the theorem is verified.

(ii) We have the theorem  $\frac{f(b) - f(a)}{b - a} = f'(c)$

Here,  $f(x) = \sin^2 x$  is continuous in  $\left[0, \frac{\pi}{2}\right]$

$$f'(x) = 2 \sin x \cos x \\ = \sin 2x$$

$\therefore f(x)$  is differentiable in  $\left(0, \frac{\pi}{2}\right)$

with

$$a = 0, b = \frac{\pi}{2}$$

$$f(a) = f(0) = \sin^2(0) = 0$$

$$f(b) = f\left(\frac{\pi}{2}\right) = \sin^2\left(\frac{\pi}{2}\right) = 1$$

The theorem becomes

$$\frac{f\left(\frac{\pi}{2}\right) - f(0)}{\frac{\pi}{2} - 0} = \sin 2c$$

$$\frac{1 - 0}{\frac{\pi}{2}} = \sin 2c$$

*i.e.*,

$$\frac{2}{\pi} = \sin 2c$$

$$2c = \sin^{-1}\left(\frac{2}{\pi}\right)$$

$$c = \frac{1}{2} \sin^{-1}\left(\frac{2}{\pi}\right)$$

$$= 0.36 \text{ which lies between } 0 \text{ and } \frac{\pi}{2}$$

Here,  $c = 0.36 \in \left(0, \frac{\pi}{2}\right)$

Thus the theorem is verified.

(iii) We have the theorem  $\frac{f(b) - f(a)}{b - a} = f'(c)$

$$f(x) = \log x \text{ is continuous in } [1, e]$$

$$f'(x) = \frac{1}{x} \text{ } f(x) \text{ is differentiable in } (1, e)$$

with

$$\begin{aligned} a &= 1, b = e \\ f(a) &= f(1) = \log 1 = 0 \\ f(b) &= f(e) = \log e = 1 \end{aligned}$$

The theorem becomes,

$$\frac{f(e) - f(1)}{e - 1} = \frac{1}{c}$$

$$\frac{1 - 0}{e - 1} = \frac{1}{c}$$

$$\frac{1}{e - 1} = \frac{1}{c}$$

$$c = e - 1$$

$2 < e < 3$  since  $1 < e - 1 < 2 < e$

So that  $c = e - 1 \in (1, e)$

Thus the theorem is verified.

(iv) we have the theorem  $\frac{f(b) - f(a)}{b - a} = f'(c)$

$f(x) = \sin^{-1} x$  is continuous in  $[0, 1]$

$$f'(x) = \frac{1}{\sqrt{1 - x^2}} \text{ which exists for all } x \neq 1$$

Therefore  $f(x)$  is differentiable in  $(0, 1)$

By Lagrange's theorem

$$\frac{f(1) - f(0)}{1 - 0} = f'(c)$$

$$\sin^{-1} 1 - \sin^{-1} 0 = \frac{1}{\sqrt{1 - c^2}}$$

$$\text{i.e.,} \quad \frac{\pi}{2} - 0 = \frac{1}{\sqrt{1 - c^2}}$$

$$\frac{\pi}{2} = \frac{1}{\sqrt{1 - c^2}} \Rightarrow \frac{4}{\pi^2} = 1 - c^2$$

$$\text{i.e.,} \quad c^2 = 1 - \frac{4}{\pi^2}$$

$$c^2 = \frac{\pi^2 - 4}{\pi^2}$$

or 
$$c = \pm \frac{\sqrt{\pi^2 - 4}}{\pi} = \pm 0.7712$$

Hence  $c = 0.7712$  lies between 0 and 1.

Therefore Lagrange's theorem is verified for  $f(x) = \sin^{-1} x$  in  $[0, 1]$ .

7. Prove that  $\frac{b-a}{\sqrt{1-a^2}} < \sin^{-1} b - \sin^{-1} a < \frac{b-a}{\sqrt{1-b^2}}$  where  $a < b < 1$ .

**Solution**

Let 
$$f(x) = \sin^{-1} x$$

$$\therefore f'(x) = \frac{1}{\sqrt{1-x^2}}$$

$f(x)$  is continuous in  $[a, b]$  and

$f(x)$  is differentiable in  $(a, b)$

Applying Lagrange's mean value theorem for  $f(x)$  in  $[a, b]$ , we get  $a < c < b$

$$\frac{\sin^{-1} b - \sin^{-1} a}{b - a} = \frac{1}{\sqrt{1-c^2}} \quad \dots(1)$$

Now  $a < c \Rightarrow a^2 < c^2 \Rightarrow -a^2 > -c^2 \Rightarrow 1 - a^2 > 1 - c^2$

Hence 
$$\frac{1}{\sqrt{1-a^2}} < \frac{1}{\sqrt{1-c^2}} \quad \dots(2)$$

Also,  $c < b$  on similar lines,

$$\frac{1}{\sqrt{1-c^2}} < \frac{1}{\sqrt{1-b^2}} \quad \dots(3)$$

Combining (2) and (3), we get

$$\frac{1}{\sqrt{1-a^2}} < \frac{1}{\sqrt{1-c^2}} < \frac{1}{\sqrt{1-b^2}}$$

or 
$$\frac{1}{\sqrt{1-a^2}} < \frac{\sin^{-1} b - \sin^{-1} a}{b - a} < \frac{1}{\sqrt{1-b^2}} \text{ by using (1)}$$

On multiplying by  $(b - a)$  which is positive, we have

$$\frac{b-a}{\sqrt{1-a^2}} < \sin^{-1} b - \sin^{-1} a < \frac{b-a}{\sqrt{1-b^2}}$$

8. Show that

$$\frac{b-a}{1-b^2} < \tan^{-1} b - \tan^{-1} a < \frac{b-a}{1+a^2}, \text{ if } 0 < a < b \text{ and deduce that } \frac{\pi}{4} + \frac{3}{25} < \tan^{-1} \frac{4}{3} < \frac{\pi}{4} + \frac{1}{6}.$$

**Solution**

Let  $f(x) = \tan^{-1} x$  is continuous in  $[a, b]$ ,  $a > 0$ .

Hence  $f'(x) = \frac{1}{1+x^2}$ ,  $f(x)$  is differentiable in  $(a, b)$ .

Applying Lagrange's theorem, we get

$$\frac{f(b) - f(a)}{b-a} = f'(c) \text{ for some } c : a < c < b$$

$$\frac{\tan^{-1} b - \tan^{-1} a}{b-a} = \frac{1}{1+c^2} \quad \dots(1)$$

$$\text{Now } c > a \Rightarrow c^2 > a^2 \Rightarrow 1 + c^2 > 1 + a^2$$

$$\therefore \frac{1}{1+c^2} < \frac{1}{1+a^2} \quad \dots(2)$$

$$\text{and } c < b \Rightarrow c^2 < b^2 \Rightarrow 1 + c^2 < 1 + b^2$$

$$\therefore \frac{1}{1+c^2} > \frac{1}{1+b^2} \quad \dots(3)$$

From (2) and (3), we obtain

$$\frac{1}{1+b^2} < \frac{1}{1+c^2} < \frac{1}{1+a^2}$$

$$\text{i.e., } \frac{1}{1+b^2} < \frac{\tan^{-1} b - \tan^{-1} a}{b-a} < \frac{1}{1+a^2} \text{ using (1)}$$

On multiplying  $(b-a)$ , we get

$$\frac{b-a}{1+b^2} < \tan^{-1} b - \tan^{-1} a < \frac{b-a}{1+a^2}$$

In particular if  $a = 1$ ,  $b = \frac{4}{3}$  then

$$\frac{\frac{4}{3}-1}{1+\frac{16}{9}} < \tan^{-1} \frac{4}{3} - \tan^{-1} 1 < \frac{\frac{4}{3}-1}{1+1}$$

$$\frac{\pi}{4} + \frac{3}{35} < \tan^{-1} \frac{4}{3} < \frac{\pi}{4} + \frac{1}{6} \quad \text{Hence proved.}$$



9. Verify Cauchy's mean value theorem for the following pairs of functions.

(i)  $f(x) = x^2 + 3$ ,  $g(x) = x^3 + 1$  in  $[1, 3]$ .

(ii)  $f(x) = \sin x$ ,  $g(x) = \cos x$  in  $\left[0, \frac{\pi}{2}\right]$ .

(iii)  $f(x) = e^x$ ,  $g(x) = e^{-x}$  in  $[a, b]$ ,

**Solution**

(i) We have Cauchy's mean value theorem

$$\frac{f(b) - f(a)}{g(b) - g(a)} = \frac{f'(c)}{g'(c)}$$

Here,  $a = 1$ ,  $b = 3$

$$f(x) = x^2 + 3$$

$$g(x) = x^3 + 1$$

$$\therefore f'(x) = 2x$$

$$g'(x) = 3x^2$$

$f(x)$  and  $g(x)$  are continuous in  $[1, 3]$ , differentiable in  $(1, 3)$

$$g'(x) \neq 0 \quad \forall x \in (1, 3)$$

Hence the theorems becomes

$$\frac{f(3) - f(1)}{g(3) - g(1)} = \frac{2c}{3c^2}$$

$$\frac{12 - 4}{28 - 2} = \frac{2}{3c} \Rightarrow \frac{8}{26} = \frac{2}{3c}$$

$$\frac{2}{13} = \frac{1}{3c}$$

or 
$$c = \frac{13}{6} = 2\frac{1}{6} \in (1, 3)$$

Thus the theorem is verified.

(ii) We have Cauchy's mean value theorem

$$\frac{f(b) - f(a)}{g(b) - g(a)} = \frac{f'(c)}{g'(c)}$$

Here,  $f(x) = \sin x$

$$g(x) = \cos x$$

$$f'(x) = \cos x$$

$$g'(x) = -\sin x$$

$$\therefore g'(x) \neq 0$$

Clearly both  $f(x)$  and  $g(x)$  are continuous in  $\left[0, \frac{\pi}{2}\right]$  and differentiable in  $\left(0, \frac{\pi}{2}\right)$ . Therefore from Cauchy's mean value theorem

$$\frac{f\left(\frac{\pi}{2}\right) - f(0)}{g\left(\frac{\pi}{2}\right) - g(0)} = \frac{f'(c)}{g'(c)} \text{ for some } c : 0 < c < \frac{\pi}{2}$$

$$\begin{aligned} \text{i.e.,} \quad \frac{1-0}{0-1} &= \frac{\cos c}{-\sin c} \\ -1 &= -\cot c \text{ or } \cot c = 1 \end{aligned}$$

$$\therefore c = \frac{\pi}{4}$$

$$\text{Clearly } c = \frac{\pi}{4} \in \left(0, \frac{\pi}{2}\right)$$

Thus Cauchy's theorem is verified.

(iii) We have Cauchy's mean value theorem

$$\frac{f(b) - f(a)}{g(b) - g(a)} = \frac{f'(c)}{g'(c)}$$

$$\begin{aligned} \text{Here } f(x) &= e^x \\ \text{and } g(x) &= e^{-x} \\ f'(x) &= e^x \\ g'(x) &= -e^{-x} \end{aligned}$$

$\therefore f(x)$  and  $g(x)$  are continuous in  $[a, b]$  and differentiable in  $(a, b)$  and also  $g'(x) \neq 0$

$\therefore$  From Cauchy's mean value theorem

$$\frac{f(b) - f(a)}{g(b) - g(a)} = \frac{f'(c)}{g'(c)}$$

$$\text{i.e., } \frac{e^b - e^a}{e^{-b} - e^{-a}} = \frac{e^c}{-e^{-c}}$$

$$\text{i.e., } \frac{e^b - e^a}{\frac{1}{e^b} - \frac{1}{e^a}} = -e^{2c}$$

$$\begin{aligned} \text{i.e., } \frac{e^a e^b (e^b - e^a)}{(e^a - e^b)} &= -e^{2c} \\ e^{a+b} &= e^{2c} \end{aligned}$$

i.e.,

$$a + b = 2c$$

or

$$c = \frac{a+b}{2}$$

∴

$$c = \frac{a+b}{2} \in (a, b)$$

Hence Cauchy's theorem holds good for the given functions.

**10.** Expand  $e^x$  in ascending powers of  $x - 1$  by using Taylor's theorem.

**Solution**

The Taylor's theorem for the function  $f(x)$  in ascending powers of  $x - a$  is

$$f(x) = f(a) + (x-a)f'(a) + \frac{(x-a)^2}{2!} f''(a) + \dots$$

Here

$$f(x) = e^x \text{ and } a = 1$$

$$f'(x) = e^x$$

$$f''(x) = e^x$$

$$f'(1) = e$$

$$f''(1) = e^1$$

and so on.

$$\begin{aligned} \therefore e^x &= e + (x-1)e + \frac{(x-1)^2}{2!} e + \dots \\ &= e \left\{ 1 + (x-1) + \frac{(x-1)^2}{2} + \dots \right\} \end{aligned}$$

**11.** Obtain the Taylor's expansion of  $\log_e x$  about  $x = 1$  up to the term containing fourth degree and hence obtain  $\log_e (1.1)$ .

**Solution**

We have Taylor's expansion about  $x = a$  given by

$$y(x) = y(a) + (x-a)y_1(a) + \frac{(x-a)^2}{2!} y_2(a) + \frac{(x-a)^3}{3!} y_3(a) + \frac{(x-a)^4}{4!} y_4(a) + \dots$$

$$y(x) = \log_e x \text{ at } a = 1$$

$$y(1) = \log_e 1 = 0$$

Differentiating  $y(x)$  successively, we get

$$y_1(x) = \frac{1}{x} \Rightarrow y_1(1) = 1$$

$$y_2(x) = \frac{-1}{x^2} \Rightarrow y_2(1) = -1$$

$$y_3(x) = \frac{2}{x^3} \Rightarrow y_3(1) = 2$$

$$y_4(x) = \frac{-6}{x^4} \Rightarrow y_4(1) = -6$$

Taylor's series up to fourth degree term with  $a = 1$  is given by

$$y(x) = y(1) + (x-1)y_1(1) + \frac{(x-1)^2}{2!}y_2(1) + \frac{(x-1)^3}{3!}y_3(1) + \frac{(x-1)^4}{4!}y_4(1)$$

Hence, 
$$\log_e x = 0 + (x-1)(1) + \frac{(x-1)^2}{2}(-1) + \frac{(x-1)^3}{6}(2) + \frac{(x-1)^4}{24}(-6)$$

$$\log_e x = (x-1) - \frac{(x-1)^2}{2} + \frac{(x-1)^3}{3} - \frac{(x-1)^4}{4}$$

Now putting  $x = 1.1$ , we have

$$\begin{aligned} \log_e(1.1) &= (0.1) - \frac{(0.1)^2}{2} + \frac{(0.1)^3}{3} - \frac{(0.1)^4}{4} \\ &= 0.0953 \end{aligned}$$

**12.** Expand  $\tan^{-1} x$  in powers of  $(x-1)$  up to the term containing fourth degree.

**Solution**

Taylor's expansion in powers of  $(x-1)$  is given by

$$y(x) = y(1) + (x-1)y_1(1) + \frac{(x-1)^2}{2!}y_2(1) + \frac{(x-1)^3}{3!}y_3(1) + \frac{(x-1)^4}{4!}y_4(1) + \dots$$

$$y(x) = \tan^{-1} x$$

$$\Rightarrow y(1) = \tan^{-1}(1) = \frac{\pi}{4}$$

$$y_1(x) = \frac{1}{1+x^2}$$

$$\Rightarrow y(1) = \frac{1}{2}$$

We have 
$$y_1 = \frac{1}{1+x^2}$$

$$(1+x^2)y_1 = 1 \tag{1}$$

Differentiate successively to obtain expressions

Hence we have to differentiate (1)

$$(1+x^2)y_2 + 2xy_1 = 0 \tag{2}$$

Putting  $x = 1$

$$2y_2(1) + (2)(1)\frac{1}{2} = 0$$

$$\therefore y_2(1) = \frac{-1}{2}$$

Differentiating (2) w.r.t.  $x$ , we get

$$(1 + x^2) y_3 + 4x y_2 + 2y_1 = 0 \quad \dots(3)$$

Putting  $x = 1$ ,  $2y_3(1) - 2 + 1 = 0$ ,

$$y_3(1) = \frac{1}{2}$$

Differentiating (3) w.r.t.  $x$ , we get

$$(1 + x^2) y_4 + 6xy_3 + 6y_2 = 0 \quad \dots(4)$$

Putting  $x = 1$

$$2y_4(1) + 3 - 3 = 0$$

$$y_4(1) = 0$$

Substituting these values in the expansion, we get

$$\tan^{-1} x = \frac{\pi}{4} + \frac{1}{2} \left\{ (x-1) - \frac{(x-1)^2}{2} + \frac{(x-1)^3}{6} \right\}$$

**13.** By using Maclaurin's theorem expand  $\log \sec x$  up to the term containing  $x^6$ .

**Solution**

Let  $y(x) = \log \sec x$ ,

$$y(0) = \log \sec 0 = 0$$

We have  $y_1 = \frac{\sec x \tan x}{\sec x} = \tan x$

$$y_1(0) = 0$$

$$y_2 = \sec^2 x$$

$$y_2(0) = 1$$

To find the higher order derivatives

Consider  $y_2 = 1 + \tan^2 x$

$$y_2 = 1 + y_1^2$$

This gives,  $y_3 = 2y_1 y_2$

Hence,  $y_3(0) = 2y_1(0) y_2(0) = 0$

and  $y_4 = 2[y_1 y_3 + y_2^2]$  so that

$$y_4(0) = 2[y_1(0) y_3(0) + y_2^2(0)] = 2[0 \cdot 1 + 1^2] = 2$$

This yields  $y_5 = 2[y_1 y_4 + y_2 y_3 + 2y_2 y_3]$

$$= 2[y_1 y_4 + 3y_2 y_3]$$

$$y_5(0) = 2[y_1(0) y_4(0) + 3y_2(0) y_3(0)]$$

$$= 2[0 \cdot 2 + 3 \cdot 1 \cdot 0] = 0$$

$$y_6 = 2[y_1 y_5 + y_2 y_4 + 3\{y_2 y_4 + y_3^2\}]$$

$$\begin{aligned}
 &= 2 [y_1 y_5 + 4y_2 y_4 + 3y_3^2] \\
 \text{This yields } y_6(0) &= 2 [y_1(0) y_5(0) + 4y_2(0) y_4(0) + 3y_3^2(0)] \\
 &= 2 [0 \cdot 0 + 4 \cdot 1 \cdot 2 + 3 \cdot 0] = 16
 \end{aligned}$$

Therefore by Maclaurin's expansion, we have

$$\begin{aligned}
 y &= y(0) + xy_1(0) + \frac{x^2}{2!} y_2(0) + \dots \\
 \log \sec x &= 0 + x \cdot 0 + \frac{x^2}{2!} (1) + \frac{x^3}{3!} (0) + \frac{x^4}{4!} \cdot 2 + \frac{x^5}{5!} (0) + \frac{x^6}{6!} \cdot 16 + \dots \\
 &= \frac{x^2}{2} + \frac{x^4}{12} + \frac{x^6}{45} + \dots
 \end{aligned}$$

**14.** Expand  $\log(1 + \sin x)$  up to the term containing  $x^4$  by using Maclaurin's theorem.

**Solution**

Let  $y = \log(1 + \sin x)$   
 $y(0) = 0$

We have,  $y_1 = \frac{\cos x}{1 + \sin x}$   
 $y_1(0) = 1$

Now,  $y_1 = \frac{\sin\left(\frac{\pi}{2} - x\right)}{1 + \cos\left(\frac{\pi}{2} - x\right)}$   
 $= \frac{2 \sin \frac{1}{2}\left(\frac{\pi}{2} - x\right) \cos \frac{1}{2}\left(\frac{\pi}{2} - x\right)}{2 \cos^2 \frac{1}{2}\left(\frac{\pi}{2} - x\right)}$

$\therefore y_1 = \tan\left(\frac{\pi}{4} - \frac{x}{2}\right)$

$\therefore y_2 = -\frac{1}{2} \sec^2\left(\frac{\pi}{4} - \frac{x}{2}\right)$   
 $= -\frac{1}{2} \left[1 + \tan^2\left(\frac{\pi}{4} - \frac{x}{2}\right)\right]$

$y_2 = \frac{-1}{2} (1 + y_1^2)$

$y_2(0) = \frac{-1}{2} (1 + 1) = -1$

$$y_3 = -\frac{1}{2} 2y_1 y_2 = -y_1 y_2$$

This gives,  $y_3(0) = -1(-1) = 1$

$$y_4 = -[y_1 y_3 + y_2^2]$$

$$y_4(0) = -[1 \times 1 + (-1)^2] = -2$$

$$y_5 = -[y_1 y_4 + y_2 y_3 + 2y_2 y_3] = -(y_1 y_4 + 3y_2 y_3)$$

which gives,  $y_5(0) = -[1(-2) + 3(-1)] = 5$

Therefore by Maclaurin's theorem, we have

$$y = y(0) + xy_1(0) + \frac{x^2}{2!} y_2(0) + \dots$$

$$\begin{aligned} \log(1 + \sin x) &= 0 + x \cdot 1 + \frac{x^2}{2!}(-1) + \frac{x^3}{3!} + \frac{x^4}{4!}(-2) + \frac{x^5}{5!}(5) + \dots \\ &= x - \frac{x^2}{2!} + \frac{x^3}{3!} - \frac{2x^4}{4!} + \frac{5x^5}{5!} + \dots \end{aligned}$$

**15.** Expand  $\log(1 + e^x)$  in ascending powers of  $x$  up to the term containing  $x^4$ .

**Solution**

Let  $y = \log(1 + e^x)$ ,

$$y(0) = \log 2$$

Now  $y_1 = \frac{e^x}{1 + e^x}$

$$y_1(0) = \frac{1}{2}$$

$$y_2 = \frac{e^x}{(1 + e^x)^2} = \frac{e^x}{1 + e^x} \cdot \frac{1}{1 + e^x} = y_1(1 - y_1)$$

$$y_2(0) = \frac{1}{2} \left(1 - \frac{1}{2}\right) = \frac{1}{4}$$

$\therefore y_3 = y_1(-y_2) + (1 - y_1)y_2 = y_2 - 2y_1 y_2$

$\therefore y_3(0) = \frac{1}{4} - 2 \cdot \frac{1}{2} \cdot \frac{1}{4} = 0$

$$y_4 = y_3 - 2(y_1 y_3 + y_2^2)$$

$$y_4(0) = 0 - 2 \left( \frac{1}{2} \cdot 0 + \frac{1}{16} \right) = -\frac{1}{8}$$

Therefore from Maclaurin's theorem, we get

$$y = y(0) + xy_1(0) + \frac{x^2}{2!} y_2(0) + \dots$$

$$\log(1 + e^x) = \log 2 + x \cdot \frac{1}{2} + \frac{x^2}{2!} \cdot \frac{1}{4} + \frac{x^3}{3!} (0) + \frac{x^4}{4!} \left(-\frac{1}{8}\right) + \dots$$

$$\log(1 + e^x) = \log 2 + \frac{x}{2} + \frac{x^2}{8} - \frac{x^4}{192} + \dots$$

16. Expand by Maclaurin's theorem  $\frac{e^x}{1+e^x}$  up to the term containing  $x^3$ .

**Solution**

Let  $y = \frac{e^x}{1+e^x}$

$$y(0) = 1$$

Now  $y = 1 - \frac{1}{1+e^x}$

$$y_1 = \frac{e^x}{(1+e^x)^2} = \frac{e^x}{1+e^x} \cdot \frac{1}{1+e^x} = y(1-y) = y - y^2$$

$$\therefore y_1(0) = \frac{1}{2} - \frac{1}{4} = \frac{1}{4}$$

$$y_2 = y_1 - 2y y_1$$

$$\therefore y_2(0) = \frac{1}{4} - 2 \cdot \frac{1}{2} \cdot \frac{1}{4} = 0$$

$$y_3 = y_2 - 2(y y_2 + y_1^2)$$

$$\therefore y_3(0) = 0 - 2 \left( \frac{1}{2} \cdot 0 + \frac{1}{16} \right) = -\frac{1}{8}$$

Therefore from Maclaurin's theorem,

$$y = y(0) + xy_1(0) + \frac{x^2}{2!} y_2(0) + \frac{x^3}{3!} y_3(0) + \dots$$

$$\frac{e^x}{1+e^x} = \frac{1}{2} + x \cdot \frac{1}{4} + \frac{x^2}{2!} (0) + \frac{x^3}{3!} \left(-\frac{1}{8}\right) + \dots$$

$$= \frac{1}{2} + \frac{x}{4} - \frac{x^3}{48} + \dots$$



17. Expand  $\tan^{-1} (1 + x)$  as far as the term containing  $x^3$  using Maclaurin's series.

**Solution**

Let  $y = \tan^{-1} (1 + x)$

$$\therefore y(0) = \tan^{-1} (1) = \frac{\pi}{4}$$

$$y_1 = \frac{1}{1 + (1 + x)^2} = \frac{1}{2 + 2x + x^2}$$

$$\therefore y_1(0) = \frac{1}{2}$$

Now  $(x^2 + 2x + 2) y_1 = 0$

$$\therefore (x^2 + 2x + 2) y_2 + (2x + 2) y_1 = 0$$

$$2y_2(0) + 2y_1(0) = 0$$

$$\therefore y_2(0) = -\frac{1}{2}$$

$$(x^2 + 2x + 2) y_3 + (2x + 2) y_2 + (2x + 2) y_2 + 2y_1 = 0$$

i.e.,  $(x^2 + 2x + 2) y_3 + 4(x + 1) y_2 + 2y_1 = 0$

$$2y_3(0) + 4\left(-\frac{1}{2}\right) + 2\left(\frac{1}{2}\right) = 0$$

$$\therefore y_3(0) = \frac{1}{2}$$

Hence by Maclaurin's theorem, we get

$$y = y(0) + xy_1(0) + \frac{x^2}{2!} y_2(0) + \frac{x^3}{3!} y_3(0) + \dots$$

$$\tan^{-1} (1 + x) = \frac{\pi}{4} + \frac{1}{2}x - \frac{1}{2} \frac{x^2}{2!} + \frac{1}{3} \frac{x^3}{3!} + \dots$$

$$= \frac{\pi}{4} + \frac{x}{2} - \frac{x^2}{4} + \frac{x^3}{18} - \dots$$

18. Expand  $e^{\sin x}$  up to the term containing  $x^4$  by Maclaurin's theorem.

**Solution**

Let  $y = e^{\sin x}$

$$y(0) = 1$$

$$y_1 = e^{\sin x} \cdot \cos x$$

$$y_1(0) = 1$$

i.e.,  $y_1 = \cos x \cdot y$

$$\begin{aligned}
 y_2 &= \cos x \cdot y_1 - \sin x \cdot y \\
 \therefore y_2(0) &= 1 - 0 = 1 \\
 y_3 &= \cos x \cdot y_2 - (2 \sin x + \cos x) y_1 \\
 \therefore y_3(0) &= 1 - (0 + 1) \cdot 1 = 0 \\
 y_4 &= \cos x \cdot y_3 - \sin x \cdot y_2 - (2 \sin x + \cos x) y_2 - (2 \cos x - \sin x) y_1 \\
 \therefore y_4(0) &= 0 - (3 \cdot 0 + 1) \cdot 1 - (2 - 0) \cdot 1 = -3
 \end{aligned}$$

Therefore from Maclaurin's expansion, we obtain

$$\begin{aligned}
 e^{\sin x} &= 1 + x \cdot 1 + \frac{x^2}{2!} \cdot 1 + \frac{x^3}{3!} (0) + \frac{x^4}{4!} (-3) + \dots \\
 &= 1 + x + \frac{x^2}{2!} - 3 \frac{x^4}{4!} + \dots
 \end{aligned}$$

**19.** Expand  $\log(x + \sqrt{x^2 + 1})$  by using Maclaurin's theorem up to the term containing  $x^3$ .

**Solution**

$$\text{Let } y = \log(x + \sqrt{x^2 + 1})$$

$$\therefore y(0) = 0$$

$$y_1 = \frac{1}{x + \sqrt{x^2 + 1}} \left[ 1 + \frac{2x}{2(\sqrt{x^2 + 1})} \right]$$

$$= \frac{1}{x + \sqrt{x^2 + 1}} \left[ \frac{\sqrt{x^2 + 1} + x}{\sqrt{x^2 + 1}} \right]$$

$$y_1 = \frac{1}{\sqrt{x^2 + 1}}$$

$$\therefore y_1(0) = 1$$

$$y_1 \sqrt{x^2 + 1} = 1$$

or  $y_1^2 (x^2 + 1) = 1$

Differentiating, we get

$$y_1^2 \cdot 2x + (x^2 + 1) \cdot 2y_1 y_2 = 0$$

i.e.,  $(x^2 + 1) y_2 + x y_1 = 0$

$$\therefore y_2(0) = 0$$

$$(x^2 + 1) y_3 + 2x y_2 + x y_2 + y_1 = 0$$

$$\text{i.e., } (x^2 + 1) y_3 + 3xy_2 + y_1 = 0$$

$$\therefore y_3(0) = -1$$

Therefore by Maclaurin's theorem, we get

$$\log \left( x + \sqrt{x^2 + 1} \right) = x - \frac{x^3}{3!} + \dots$$

### EXERCISE 1.3

1. Verify Rolle's theorem for the following functions in the given intervals:

$$(i) \quad x^2 - 6x + 8 \text{ in } [2, 4] \quad \left[ \text{Ans. } c = 3 \right]$$

$$(ii) \quad 2x^2 + 2x - 5 \text{ in } [-3, 2] \quad \left[ \text{Ans. } c = -1/2 \right]$$

$$(iii) \quad x^3 - 3x^2 - 9x + 4 \text{ in } [-3, 3] \quad \left[ \text{Ans. } c = -1 \right]$$

$$(iv) \quad 2x^3 - 2x + 5 \text{ in } [-1, 1] \quad \left[ \text{Ans. } c = \pm \frac{1}{\sqrt{3}} \right]$$

$$(v) \quad x^3 - 3x^2 - 4x + 5 \text{ in } [-2, 2] \quad \left[ \text{Ans. } c = \frac{3 - \sqrt{21}}{3} \right]$$

$$(vi) \quad x^3 + 2x^2 - 4x + 5 \text{ in } [-2, 2] \quad \left[ \text{Ans. } c = \frac{2}{3} \right]$$

$$(vii) \quad (x - a)^3 (x - b)^4 \text{ in } [a, b] \quad \left[ \text{Ans. } c = \frac{4a + 3b}{7} \right]$$

2. Find whether Rolle's theorem is applicable to the following functions. Justify your answer.

$$(i) \quad f(x) = 2 + (x - 1)^{2/3} \text{ in } [0, 2] \quad \left[ \text{Ans. } f(x) \text{ is not differentiable at } x = 0 \right]$$

$$(ii) \quad f(x) = x - 1 \text{ in } [0, 2] \quad \left[ \text{Ans. } f(x) \text{ is not differentiable at } x = 1 \right]$$

$$(iii) \quad f(x) = \tan x \text{ in } [0, \pi] \quad \left[ \text{Ans. } \tan x \text{ is discontinuous at } x = \pi/2 \in (0, \pi) \right]$$

$$(iv) \quad f(x) = \sec x \text{ in } [0, 2\pi] \quad \left[ \text{Ans. } \sec x \text{ is discontinuous at } x = \pi/2 \text{ and } x = 3\pi/2 \text{ both lie in } (0, 2\pi) \right]$$

$$(v) \quad f(x) = x^{2/3} \text{ in } [-8, 8] \quad \left[ \text{Ans. } f(x) \text{ is not differentiable at } x = 0 \right]$$

3. Verify Lagrange's mean value theorem for the following functions:

$$(i) \quad f(x) = 2x^2 - 7x + 10 \text{ in } [2, 5] \quad \left[ \text{Ans. } c = 3.5 \right]$$

$$(ii) \quad f(x) = x(x - 1)(x - 2) \text{ in } [0, 1/2] \quad \left[ \text{Ans. } c = \frac{6 - \sqrt{21}}{6} \right]$$

- (iii)  $f(x) = \tan^{-1} x$  in  $[0, 1]$   $\left[ \text{Ans. } c = \left( \frac{4}{\pi} - 1 \right)^{1/2} \right]$
- (iv)  $f(x) = e^x$  in  $[0, 1]$   $[\text{Ans. } \log(e-1)]$
- (v)  $f(x) = (x^2 - 4)(x - 3)$  in  $[1, 4]$   $[\text{Ans. } c = 1 + \sqrt{3}]$
- (vi)  $f(x) = \cos^2 x$  in  $[0, \pi/2]$   $\left[ \text{Ans. } c = \frac{1}{2} \sin^{-1} \frac{2}{\pi} = 0.345 \right]$
- (vii)  $f(x) = \sqrt{x^2 - 4}$  in  $[2, 4]$   $[\text{Ans. } c = \sqrt{6}]$

4. Verify Cauchy's mean value theorem for the following pairs of functions:

- (i)  $f(x) = \sqrt{x}$ ,  $g(x) = \frac{1}{\sqrt{x}}$  in  $[a, b]$   $[\text{Ans. } c = \sqrt{ab}]$
- (ii)  $f(x) = x^2$ ,  $g(x) = \sqrt{x}$  in  $[1, 4]$   $\left[ \text{Ans. } c = \left( \frac{15}{4} \right)^{2/3} \right]$
- (iii)  $f(x) = \tan^{-1} x$ ,  $g(x) = x$  in  $\left[ \frac{1}{\sqrt{3}}, 1 \right]$   $\left[ \text{Ans. } c = \frac{\{\sqrt{3}(12 - \pi) - 12\}^{1/2}}{\pi \sqrt{3}} \right]$
- (iv)  $f(x) = \sin x$ ,  $g(x) = \cos x$  in  $[a, b]$   $\left[ \text{Ans. } c = \frac{a+b}{2} \right]$
- (v)  $f(x) = \log x$ ,  $g(x) = \frac{1}{x}$  in  $[1, e]$   $\left[ \text{Ans. } c = \frac{e}{e-1} \right]$

5. Expand  $\sin x$  in ascending powers of  $x - \pi/2$  using Taylor's series.

$$\left[ \text{Ans. } \sin x = 1 - \frac{1}{2!} \left( x - \frac{\pi}{2} \right)^2 + \frac{1}{4!} \left( x - \frac{\pi}{2} \right)^4 - \dots \right]$$

6. Using Taylor's Theorem expand  $\log x$  in powers of  $x - 1$  up to the term containing  $(x - 1)^4$ .

$$\left[ \text{Ans. } \log x = (x-1) - \frac{1}{2}(x-1)^2 + \frac{1}{3}(x-1)^3 - \frac{1}{4}(x-1)^4 + \dots \right]$$

7. Using Maclaurin's theorem prove the following:

- (i)  $\sec x = 1 + \frac{x^2}{2!} + \frac{5x^4}{4!} + \dots$
- (ii)  $a^x = 1 + (\log a)x + (\log a)^2 \frac{x^2}{2!} + (\log a)^3 \frac{x^3}{3!} + \dots$
- (iii)  $\sin^{-1} x = x + \frac{x^3}{6} + \frac{3x^5}{40} + \dots$

$$(iv) \log(1 + \cos x) = \log 2 - \frac{x^2}{4} - \frac{x^4}{96} + \dots$$

$$(v) \log(1 + \tan x) = x - \frac{x^2}{2!} + \frac{4x^3}{3!} + \dots$$

$$(vi) \log(\sec x + \tan x) = x + \frac{x^3}{6} + \frac{x^5}{24} + \dots$$

$$(vii) \log(1 + \sin^2 x) = x^5 - \frac{5}{6}x^4 + \dots$$

$$(viii) e^x \cos x = 1 + x - \frac{x^3}{3} + \dots$$

(ix) Obtain the Maclaurin's expansion for the function  $e^{a \sin^{-1} x}$ .

$$\left[ \text{Ans. } e^{a \sin^{-1} x} = 1 + ax + \frac{a^2}{2!}x^2 + \frac{a(1^2 + a^2)}{3!}x^3 + \frac{a^2(2^2 + a^2)}{4!}x^4 + \dots \right]$$

(x) Expand  $\sin(m \sin^{-1} x)$  by Maclaurin's theorem up to the term containing  $x^5$ .

$$\left[ \text{Ans. } \sin(m \sin^{-1} x) = mx + \frac{m(1^2 - m^2)}{3!}x^3 + \frac{m(1^2 - m^2)(3^2 - m^2)}{5!}x^5 + \dots \right]$$

### ADDITIONAL PROBLEMS (from Previous Years VTU Exams.)

1. Find the radius of curvature of the curve  $x^3 + y^3 = 3axy$  at the point  $\left(\frac{3a}{2}, \frac{3a}{2}\right)$ .

**Solution.** Refer page no. 7. Example 7.

2. State and prove Lagrange's mean value theorem.

**Solution.** Refer page no. 27.

3. State Taylor's theorem for a function of single variable. Using Maclaurin's series, obtain the series of  $e^{\sin x}$  as far as the term containing  $x^4$ .

**Solution.** Refer page no. 29 for first part and page no. 48 for second part. Example 18.

4. State Rolle's theorem. Verify Rolle's theorem for  $f(x) = (x - a)^m (x - b)^n$  in  $[a, b]$  given  $m$  and  $n$  are positive integers.

**Solution.** Refer page no. 27 for first part and page no. 29 for second part. Example 3.

5. Expand  $\log(1 + \cos x)$  by Maclaurin's series up to the term containing  $x^4$ .

**Solution.** Let  $y = \log(1 + \cos x)$ , then  $y(0) = \log 2$

We find that

$$y_1 = -\frac{\sin x}{1 + \cos x} \Rightarrow y_1(0) = 0$$

$$y_2 = - \left\{ \frac{(\cos x)(1 + \cos x) + \sin^2 x}{(1 + \cos x)^2} \right\} = - \left\{ \frac{\cos x}{1 + \cos x} + y_1^2 \right\}$$

$$\Rightarrow y_2(0) = -\frac{1}{2}$$

$$y_3 = - \left\{ \frac{(-\sin x)(1 + \cos x) + \cos x \sin x}{(1 + \cos x)^2} + 2y_1 y_2 \right\}$$

$$= \frac{\sin x}{1 + \cos x} - \frac{\cos x \sin x}{(1 + \cos x)^2} - 2y_1 y_2$$

$$= y_1 \left\{ -1 + \frac{\cos x}{1 + \cos x} - 2y_2 \right\} \Rightarrow y_3(0) = 0$$

$$y_4 = y_2 \left\{ -1 + \frac{\cos x}{1 + \cos x} - 2y_2 \right\} + y_1 \left\{ \frac{-\sin x(1 + \cos x) + \cos x \sin x}{(1 + \cos x)^2} - 2y_3 \right\}$$

$$= y_2 \left\{ -1 + \frac{\cos x}{1 + \cos x} - 2y_2 \right\} + y_1 \left\{ y_1 - \frac{\cos x}{1 + \cos x} - 2y_3 \right\}$$

$$\Rightarrow y_4(0) = -\frac{1}{4}$$

Thus, for  $y = \log(1 + \cos x)$ , we have

$$y(0) = \log 2, y_1(0) = 0, y_2(0) = -\frac{1}{2}, y_3(0) = 0$$

$$y_4(0) = -\frac{1}{4}, \dots$$

According, the Maclaurin's series expansion gives

$$\log(1 + \cos x) = \log 2 - \frac{1}{2} \left( \frac{x^2}{2!} \right) - \frac{1}{4} \left( \frac{x^4}{4!} \right) + \dots$$

$$= \log 2 - \frac{x^2}{4} - \frac{x^4}{96} + \dots$$

6. Obtain the formula for the radius of curvature in polar form.

**Solution.** Refer page no. 19.

7. If  $\rho_1, \rho_2$  be the radii of curvature at the extremities of any focal chord of the cardioid

$$r = a(1 + \cos \theta) \text{ show that } \rho_1^2 + \rho_2^2 = \frac{16a^2}{9}.$$

**Solution.** Let  $\rho_1$  be the radius of curvature at  $(r, \theta)$  then  $\rho_2$  is the radius of curvature at  $(r, \theta + \pi)$  on the curve  $r = a(1 + \cos \theta)$ .

Here,  $r = a(1 + \cos \theta)$

⇒

$$r_1 = -a \sin \theta \quad \text{and}$$

$$r_2 = -a \cos \theta$$

$$\begin{aligned} \rho_1 &= \frac{(r^2 + r_1^2)^{\frac{3}{2}}}{r^2 + 2r_1^2 - rr_2} \\ &= \frac{\{a^2(1 + \cos\theta)^2 + a^2 \sin^2 \theta\}^{\frac{3}{2}}}{a^2(1 + \cos\theta)^2 + 2a^2 \sin^2 \theta + a^2(1 + \cos\theta)\cos\theta} \\ &= \frac{\{a^2(1 + 2\cos\theta + \cos^2 \theta + \sin^2 \theta)\}^{\frac{3}{2}}}{a^2\{1 + 2\cos\theta + \cos^2 \theta + 2\sin^2 \theta + \cos\theta + \cos^2 \theta\}} \\ &= \frac{\{a^2 \times 2(1 + \cos\theta)\}^{\frac{3}{2}}}{a^2\{3(1 + \cos\theta)\}} \\ &= \frac{\left\{a^2 \times 2 \times 2 \cos^2 \frac{\theta}{2}\right\}^{\frac{3}{2}}}{a^2 \times 3 \times 2 \cos^2 \frac{\theta}{2}} \quad \left(\text{where } 1 + \cos \theta = 2\cos^2 \frac{\theta}{2}\right) \\ &= \frac{8a^3 \cos^3 \frac{\theta}{2}}{6a^2 \cos^2 \frac{\theta}{2}} = \frac{4}{3} a \cos \frac{\theta}{2} \end{aligned}$$

$\rho_2$  is obtained from  $\rho_1$  by replacing  $\theta$  by  $\theta + \pi$ .

$$\therefore \rho_2 = \frac{4}{3} a \cos \left( \frac{\theta + \pi}{2} \right)$$

$$= \frac{4}{3} a \cos \left( \frac{\theta}{2} + \frac{\pi}{2} \right)$$

$$\rho_2 = -\frac{4}{3} a \sin \frac{\theta}{2}$$

$$\text{Now, } \rho_1^2 + \rho_2^2 = \left( \frac{4}{3} a \cos \frac{\theta}{2} \right)^2 + \left( -\frac{4}{3} a \sin \frac{\theta}{2} \right)^2$$

$$= \frac{16}{9} a^2 \left( \cos^2 \frac{\theta}{2} + \sin^2 \frac{\theta}{2} \right)$$

$$= \frac{16}{9} a^2$$

$$\therefore \rho_1^2 + \rho_2^2 = \frac{16}{9} a^2.$$

8. State and prove Cauchy's mean value theorem.

**Solution.** Refer page no. 28, Section 1.3.3.

9. Show that for the curve  $r^2 \sec 2\theta = a^2$ ,  $\rho = \frac{a^2}{3r}$ .

**Solution.** For the given curve, we have

$$r^2 = a^2 \cos 2\theta$$

Differentiating this w.r.t.  $\theta$ , we get

$$2r \cdot \frac{dr}{d\theta} = -2a^2 \sin 2\theta$$

or 
$$\frac{d\theta}{dr} = -\frac{r}{a^2 \sin 2\theta}$$

Therefore,

$$\begin{aligned} \tan \phi = r \cdot \frac{d\theta}{dr} &= -\frac{r^2}{a^2 \sin 2\theta} \\ &= -\frac{\cos 2\theta}{\sin 2\theta} \\ &= -\cot 2\theta \\ &= \tan \left( \frac{\pi}{2} + 2\theta \right) \end{aligned}$$

Using the given equation

So that, 
$$\phi = \frac{\pi}{2} + 2\theta$$

Hence 
$$\begin{aligned} p &= r \sin \phi \\ &= r \sin \left( \frac{\pi}{2} + 2\theta \right) \\ &= r \cos 2\theta \\ &= r \cdot \frac{r^2}{a^2} \\ &= \frac{r^3}{a^2} \end{aligned}$$

$$\left( \text{where } \cos 2\theta = \frac{r^2}{a^2} \right)$$

This is the pedal equation of the given curve. From this, we get

$$\frac{dp}{dr} = \frac{3r^2}{a^2} \quad \text{or} \quad \frac{dr}{dp} = \frac{a^2}{3r^2}$$

Therefore, 
$$\rho = r \cdot \frac{dr}{dp} = \frac{a^2}{3r}$$

*i.e.*,  $\rho$  is inversely proportional to  $r$ .



10. Obtain Taylor's series expansion of  $\log_e x$  about the point  $x = 1$  up to the fourth degree term and hence obtain  $\log_e 1.1$ .

**Solution.** Refer page no. 42. Example 11.

11. For the curve  $\theta = \cos^{-1} \left( \frac{r}{k} \right) - \frac{\sqrt{k^2 - r^2}}{r}$  prove that  $r \frac{ds}{dr} = \text{constant}$ .

**Solution.** Refer page no. 24. Example 4, point (iii).

12. State Rolle's theorem and verify the same for  $f(x) = \log \left[ \frac{x^2 + ab}{x(a+b)} \right]$  in  $[a, b]$ .

**Solution.** Refer page no. 27 and page no. 34. Example 5.

13. Find the first-four non-zero terms in the expansion of  $f(x) = \frac{x}{e^{x-1}}$  using Maclaurin's series.

**Solution.** We have Maclaurin's series

$$y(x) = y(0) + xy_1(0) + \frac{x^2}{2!} y_2(0) + \frac{x^3}{3!} y_3(0) + \dots$$

By data  $f(x) = y(x) = \frac{x}{e^{x-1}} \Rightarrow y(0) = 0$

i.e.,  $y = \frac{x}{e^x \cdot e^{-1}} = e \cdot \frac{x}{e^x}$

or  $e^x y = ex$

We differentiate this equation successively four times and evaluate at  $x = 0$  as follows.

$$e^x y_1 + e^x y = e \Rightarrow y_1(0) = e$$

$$e^x y_2 + 2e^x y_1 + e^x y = 0 \Rightarrow y_2(0) = -2e$$

$$e^x y_3 + 3e^x y_2 + 3e^x y_1 + e^x y = 0 \Rightarrow y_3(0) = 3e$$

Thus by substituting these values in the expansion, we get

$$\frac{x}{e^{x-1}} = e \left( x - x^2 + \frac{x^3}{2} \dots \right)$$

14. State Lagrange's mean value theorem. Prove that  $0 < a < b \frac{b-a}{1+b^2} < \tan^{-1} b - \tan^{-1} a < \frac{b-a}{1+a^2}$ .

**Solution.** Refer page no. 27 and page no. 39. Example 8.

15. Show that

$$\sqrt{1 + \sin 2x} = 1 + x - \frac{x^2}{2} - \frac{x^3}{6} + \frac{x^4}{24} \dots$$

**Solution.** We have  $y(x) = y(0) + xy_1(0) + \frac{x^2}{2!} y_2(0) + \dots$

Let  $y = \sqrt{1 + \sin 2x}$

$$= \sqrt{\cos^2 x + \sin^2 x + 2 \sin x \cos x}$$

$$= \sqrt{(\cos x + \sin x)^2} = \cos x + \sin x$$

Thus,

$$y = \cos x + \sin x \quad \Rightarrow \quad y(0) = 1$$

$$y_1 = -\sin x + \cos x \quad \Rightarrow \quad y_1(0) = 1$$

$$y_2 = -\cos x - \sin x = -y \quad \Rightarrow \quad y_2(0) = -1$$

$$y_3 = -y_1 \quad \Rightarrow \quad y_3(0) = -1$$

$$y_4 = -y_2 \quad \Rightarrow \quad y_4(0) = 1$$

Substituting these values in the expansion of  $y(x)$ , we get

$$\sqrt{1 + \sin 2x} = 1 + x - \frac{x^2}{2} - \frac{x^3}{6} + \frac{x^4}{24} \dots \dots \dots$$

16. For the curve  $r = a(1 - \cos \theta)$ , prove that  $\frac{e^2}{r} = \text{constant}$ .

**Solution.** Refer page no. 22. Example 2.

17. State and prove Cauchy's mean value theorem.

**Solution.** Refer page no. 28.

## OBJECTIVE QUESTIONS

1. The rate at which the curve is called
 

(a) Radius of curvature	(b) Curvature	
(c) Circle of curvature	(d) Evolute.	[Ans. b]
  
2. The radius of curvature of  $r = a \cos \theta$  at  $(r, \theta)$  is
 

(a) $a$	(b) $2a$	
(c) $\frac{1}{2}a$	(d) $a^2$ .	[Ans. d]
  
3. The radius of curvature of  $y = e^{-x^2}$  at  $(0, 1)$  is
 

(a) 1	(b) 2	
(c) $\frac{1}{2}$	(d) $\frac{1}{3}$ .	[Ans. c]
  
4. The radius of the circle of curvature is
 

(a) 1	(b) $\rho$	
(c) $\frac{1}{\rho}$	(d) $\rho^2$ .	[Ans. b]

5. The radius of curvature of the curve  $Pa^2 = r^3$  is

(a)  $\frac{a^2}{3r}$

(b)  $\frac{a^2b^2}{p^3}$

(c)  $\frac{a^3}{3}$

(d) None of these.

[Ans. a]

6. The ellipse in the pedal form  $\frac{1}{p^2} = \frac{1}{a^2} + \frac{1}{b^2} - \frac{r^2}{a^2b^2}$  the radius of curvature at the point  $(p, r)$  is

(a)  $\frac{a^2b}{p}$

(b)  $\frac{a^2b^2}{b^2}$

(c)  $\frac{a^2b^2}{p^3}$

(d) None of these.

[Ans. c]

7. Lagrange's mean value theorem is a special case of

(a) Rolle's theorem

(b) Cauchy's mean value theorem

(c) Taylor's theorem

(d) Taylor's series.

[Ans. b]

8. The result "If  $f'(x) = 0 \forall x$  in  $[a, b]$  then  $f(x)$  is a constant in  $[a, b]$ " can be obtained from

(a) Rolle's theorem

(b) Lagrange's mean value theorem

(c) Cauchy's mean value theorem

(d) Taylor's theorem.

[Ans. b]

9. The first-three non-zero terms in the expansion of  $e^x \tan x$  is

(a)  $x + x^2 + \frac{1}{3}x^3$

(b)  $x + \frac{x^3}{3} + \frac{2}{5}x^5$

(c)  $x + x^2 + \frac{5}{6}x^3$

(d)  $x + \frac{x^3}{3} + \frac{1}{6}x^5$ .

[Ans. c]

10. In the expansion of  $\tan x$  and  $\tan^{-1} x$ , considering first-three non-zero terms

(a) The first-three non-zero terms are same

(b) The first-two non-zero terms are same

(c) All coefficients are same

(d) First-two coefficients are same.

[Ans. c]

11. The derivative  $f'(x)$  of a function  $f(x)$  is positive or zero in  $(a, b)$  without being zero always. Then in  $(a, b)$

(a)  $f(b) < f(a)$

(b)  $f(b) > f(a)$

(c)  $f(b) - f(a) = f'(c), c \in (a, b)$

(d)  $f(b) = f(a)$ .

[Ans. b]

12. The Lagrange's mean value theorem for the function  $f(x) = e^x$  in the interval  $[0, 1]$  is

(a)  $C = 0.5413$

(b)  $C = 2.3$

(c)  $C = 0.3$

(d) None of these.

[Ans. a]

13. The Maclaurin's series expansion of  $e^x$  is

- (a)  $1 + x + \frac{x^2}{2!} + \frac{x^3}{3!} + \dots$  (b)  $1 + x - \frac{x^2}{2!} + \frac{x^3}{3!} + \dots$   
 (c)  $x - \frac{x^2}{2!} + \frac{x^3}{3!} + \dots$  (d) None of these.

[Ans. a]

14. The Maclaurin's series expansion of  $\log(1+x)$  is

- (a)  $x - \frac{x^3}{3} + \frac{x^5}{5} + \dots$  (b)  $x + \frac{x^2}{2!} + \frac{x^3}{3!} + \frac{x^4}{4!} + \dots$   
 (c)  $x - \frac{x^2}{2!} + \frac{x^3}{3!} - \frac{x^4}{4!} + \dots$  (d)  $1 + x - \frac{x^2}{2!} + \frac{x^3}{3!} + \dots$

[Ans. c]

15. The Maclaurin's series expansion of  $\cos x$  is

- (a)  $1 - \frac{x^2}{2!} + \frac{x^4}{4!} - \frac{x^6}{6!} + \dots$  (b)  $x - \frac{x^3}{3!} + \frac{x^5}{5!} + \dots$   
 (c)  $1 + \frac{x^2}{2!} + \frac{x^3}{3!} + \frac{x^4}{4!} + \dots$  (d) None of these.

[Ans. a]

16. The radius of curvature at a point  $(x, 4)$  of  $y = a \cosh\left(\frac{x}{a}\right)$  is

- (a)  $\frac{y^2}{a}$  (b)  $\frac{x^2}{a}$   
 (c)  $\frac{a^2}{y}$  (d) None of these.

[Ans. a]

17. The radius of curvature of the curve  $y = 4 \sin x - \sin 2x$  at  $x = \frac{\pi}{2}$  is

- (a)  $\frac{5}{4}$  (b)  $\frac{\sqrt{5}}{4}$   
 (c)  $\frac{5\sqrt{5}}{4}$  (d) None of these.

[Ans. c]

18. The radius of curvature at a point  $t$  on the curve  $x = at^2$  and  $y = 2at$  is

- (a)  $2a(1+t^2)^{\frac{3}{2}}$  (b)  $a(1+t^2)^3$   
 (c)  $2a(1+t^5)^{\frac{3}{2}}$  (d)  $2a^2(1+t^2)^{\frac{3}{2}}$ .

[Ans. a]

19. The length of the perpendicular from the origin on to the line  $ax + by = c$  is

- (a)  $p = \left| \frac{c}{(a^2 + b^2)^{\frac{1}{2}}} \right|$  (b)  $p = \left| \frac{a}{(a^2 + b^2)^2} \right|$   
 (c)  $p = \left| \frac{b}{(a^2 + b^2)^{\frac{1}{2}}} \right|$  (d) None of these.

[Ans. a]

20. The radii of curvature of the curve  $2ap^2 = r^3$  is

(a)  $\frac{2}{5}\sqrt{2ar}$

(b)  $\frac{2}{3}\sqrt{2ar}$

(c)  $\frac{4}{5}\sqrt{2ar}$

(d) None of these.

[Ans. b]

21. The radii of curvature of the curve  $r = ae^{\theta \cot \alpha}$  is

(a)  $r \operatorname{cosec} \alpha$

(b)  $r \cot \alpha$

(c)  $\theta \cot \alpha$

(d) None of these.

[Ans. a]

22. The radii of curvature of the curve  $\frac{2a}{r} = 1 - \cos \theta$  is

(a)  $\frac{2r^{3/2}}{\sqrt{a}}$

(b)  $\frac{4r^{3/2}}{\sqrt{a}}$

(c)  $\frac{ar^{3/2}}{2}$

(d) None of these.

[Ans. a]

□□□

## Differential Calculus-II

---

### 2.1 INDETERMINATE FORMS

If  $f(x)$  and  $g(x)$  are two functions, then we know that

$$\lim_{x \rightarrow a} \frac{f(x)}{g(x)} = \frac{\lim_{x \rightarrow a} f(x)}{\lim_{x \rightarrow a} g(x)}$$

If  $\lim_{x \rightarrow a} f(x) = 0$  and  $\lim_{x \rightarrow a} g(x) = 0$ , then the expression  $\frac{f(x)}{g(x)}$  is said to have the indeterminate form  $\frac{0}{0}$ , at  $x = 0$ .

If  $\lim_{x \rightarrow a} f(x) = \infty$ ,  $\lim_{x \rightarrow a} g(x) = \infty$ , then  $\frac{f(x)}{g(x)}$  is said to have the indeterminate form  $\frac{\infty}{\infty}$ .

The other indeterminate forms are  $\infty - \infty$ ,  $0 \times \infty$ ,  $0^0$ ,  $1^\infty$ ,  $\infty^0$ .

#### 2.1.1 Indeterminate Form $\frac{0}{0}$

Here, we shall give a method called L' Hospital's rule to evaluate the limits of the expressions which take the indeterminate forms  $\frac{0}{0}$  and  $\frac{\infty}{\infty}$ .

#### L' Hospital's Theorem

Let  $f(x)$  and  $g(x)$  be two functions such that

(1)  $\lim_{x \rightarrow a} f(x) = 0$  and  $\lim_{x \rightarrow a} g(x) = 0$

(2)  $f'(a)$  and  $g'(a)$  exist and  $g'(a) \neq 0$

then, 
$$\lim_{x \rightarrow a} \frac{f(x)}{g(x)} = \lim_{x \rightarrow a} \frac{f'(x)}{g'(x)}$$

**Proof.** Suppose  $f(x)$  and  $g(x)$  satisfy the conditions of Cauchy's mean value theorem in the interval  $[a, x]$ . Then, we have

$$\frac{f(x) - f(a)}{g(x) - g(a)} = \frac{f'(c)}{g'(c)} \text{ where } c \text{ lies between } a \text{ and } x \text{ i.e., } a < c < x$$

Since,  $f(a) = 0$ ,  $g(a) = 0$  and as  $x \rightarrow a$ ,  $c \rightarrow a$ , we get

$$\frac{f(x)}{g(x)} = \frac{f'(c)}{g'(c)}$$

Hence, 
$$\lim_{x \rightarrow a} \frac{f(x)}{g(x)} = \lim_{c \rightarrow a} \frac{f'(c)}{g'(c)} = \lim_{x \rightarrow a} \frac{f'(x)}{g'(x)} \text{ (replacing } c \text{ by } x)$$

If  $f'(a) = 0 = g'(a)$ , then this theorem can be extended as follows:

$$\begin{aligned} \lim_{c \rightarrow a} \frac{f(x)}{g(x)} &= \lim_{x \rightarrow a} \frac{f''(x)}{g''(x)} \\ &= \lim_{x \rightarrow a} \frac{f'''(x)}{g'''(x)}, \text{ if } f''(a) = 0 = g''(a) \end{aligned}$$

and so on.

### WORKED OUT EXAMPLES

1. Evaluate:  $\lim_{x \rightarrow 0} \frac{x - \sin x}{x^3}$ .

**Solution** 
$$L = \lim_{x \rightarrow 0} \frac{x - \sin x}{x^3} \quad \left[ \frac{0}{0} \right] \text{ form}$$

By L' Hospital rule

$$L = \lim_{x \rightarrow 0} \frac{1 - \cos x}{3x^2} \quad \left[ \frac{0}{0} \right] \text{ form}$$

$$= \lim_{x \rightarrow 0} \frac{\sin x}{6x} \quad \left[ \frac{0}{0} \right] \text{ form}$$

$$= \lim_{x \rightarrow 0} \frac{\cos x}{6} = \frac{1}{6}.$$

2. Evaluate:  $\lim_{x \rightarrow 0} \frac{\tan x - \sin x}{\sin^3 x}$ .

**Solution** 
$$L = \lim_{x \rightarrow 0} \frac{\tan x - \sin x}{\sin^3 x} \quad \left[ \frac{0}{0} \right] \text{ form}$$

$$= \lim_{x \rightarrow 0} \frac{\frac{\sin x}{\cos x} - \sin x}{\sin^3 x}$$

$$= \lim_{x \rightarrow 0} \frac{1 - \cos x}{\sin^2 x \cos x} \quad \left[ \frac{0}{0} \right] \text{ form}$$

By L' Hospital rule

$$= \lim_{x \rightarrow 0} \frac{\sin x}{-\sin^3 x + 2 \sin x \cos^2 x}$$

and

$$= \lim_{x \rightarrow 0} \frac{1}{-\sin^2 x + 2 \cos^2 x} = \frac{1}{-0 + 2} = \frac{1}{2}.$$

3. Evaluate:  $\lim_{x \rightarrow 0} \frac{a^x - b^x}{\sin x}$ .

**Solution**  $L = \lim_{x \rightarrow 0} \frac{a^x - b^x}{\sin x} \quad \left[ \frac{0}{0} \right] \text{ form}$

By L' Hospital rule

$$= \lim_{x \rightarrow 0} \frac{a^x \log a - b^x \log b}{\cos x} \quad \left[ \frac{0}{0} \right] \text{ form}$$

$$= \frac{\log a - \log b}{1}$$

$$= \log \left( \frac{a}{b} \right).$$

4. Evaluate:  $\lim_{x \rightarrow 0} \frac{x \sin x}{(e^x - 1)^2}$ .

**Solution**  $L = \lim_{x \rightarrow 0} \frac{x \sin x}{(e^x - 1)^2} \quad \left[ \frac{0}{0} \right] \text{ form}$

By L' Hospital rule

$$L = \lim_{x \rightarrow 0} \frac{x \cos x + \sin x}{2(e^x - 1) \cdot e^x} \quad \left[ \frac{0}{0} \right] \text{ form}$$

$$= \lim_{x \rightarrow 0} \frac{-x \sin x + \cos x + \cos x}{2[2e^{2x} - e^x]}$$

$$= \frac{2}{2(2-1)} = 1.$$

5. Evaluate:  $\lim_{x \rightarrow 0} \frac{x \cos x - \log(1+x)}{x^2}$ .

**Solution**  $L = \lim_{x \rightarrow 0} \left[ \frac{x \cos x - \log(1+x)}{x^2} \right] \quad \left[ \frac{0}{0} \right] \text{ form}$



By L' Hospital rule

$$\begin{aligned}
 &= \lim_{x \rightarrow 0} \left[ \frac{\cos x - x \sin x - \frac{1}{1+x}}{2x} \right] && \left[ \frac{0}{0} \right] \text{ form} \\
 &= \lim_{x \rightarrow 0} \left[ \frac{-\sin x - x \cos x - \sin x + \frac{1}{(1+x)^2}}{2} \right] \\
 &= \frac{1}{2}.
 \end{aligned}$$

6. Evaluate:  $\lim_{x \rightarrow 0} \frac{\cos hx - \cos x}{x \sin x}$ .

**Solution**  $L = \lim_{x \rightarrow 0} \frac{\cos hx - \cos x}{x \sin x}$   $\left[ \frac{0}{0} \right]$  form

By L' Hospital rule

$$\begin{aligned}
 &= \lim_{x \rightarrow 0} \frac{\sin hx + \sin x}{x \cos x + \sin x} && \left[ \frac{0}{0} \right] \text{ form} \\
 &= \lim_{x \rightarrow 0} \frac{\cos hx + \cos x}{-x \sin x + \cos x + \cos x} \\
 &= \frac{2}{2} = 1.
 \end{aligned}$$

7. Evaluate:  $\lim_{x \rightarrow 0} \frac{a^x - b^x}{x}$ .

**Solution**  $L = \lim_{x \rightarrow 0} \frac{a^x - b^x}{x}$   $\left[ \frac{0}{0} \right]$  form

By L' Hospital rule

$$\begin{aligned}
 &= \lim_{x \rightarrow 0} \frac{a^x \log a - b^x \log b}{1} \\
 &= \log a - \log b = \log \left( \frac{a}{b} \right).
 \end{aligned}$$

8. Evaluate:  $\lim_{x \rightarrow \frac{\pi}{4}} \frac{\sec^2 x - 2 \tan x}{1 + \cos 4x}$ .

**Solution**  $L = \lim_{x \rightarrow \frac{\pi}{4}} \frac{\sec^2 x - 2 \tan x}{1 + \cos 4x}$   $\left[ \frac{0}{0} \right]$  form

By L' Hospital rule

$$\begin{aligned}
 &= \lim_{x \rightarrow \frac{\pi}{4}} \frac{2 \sec^2 x \tan x - 2 \sec^2 x}{-4 \sin 4x} \\
 &= \lim_{x \rightarrow \frac{\pi}{4}} \frac{-\sec^2 x (\tan x - 1)}{2 \sin 4x} \quad \left[ \frac{0}{0} \right] \text{ form} \\
 &= \lim_{x \rightarrow \frac{\pi}{4}} - \left\{ \frac{\sec^2 x \cdot \sec^2 x + (\tan x - 1) \cdot 2 \sec^2 x \tan x}{8 \cos 4x} \right\} \\
 &= \frac{-\sec^4 \frac{\pi}{4} + 0}{8 \cos \pi} \\
 &= \frac{-4}{-8} = \frac{1}{2}.
 \end{aligned}$$

9. Evaluate:  $\lim_{x \rightarrow 0} \frac{\sin hx - \sin x}{x \sin^2 x}$ .

**Solution**  $L = \lim_{x \rightarrow 0} \frac{\sin hx - \sin x}{x \sin^2 x} \quad \left[ \frac{0}{0} \right] \text{ form}$

By L' Hospital rule

$$\begin{aligned}
 &= \lim_{x \rightarrow 0} \frac{\cos hx - \cos x}{\sin^2 x + 2x \sin x \cos x} \quad \left[ \frac{0}{0} \right] \text{ form} \\
 &= \lim_{x \rightarrow 0} \frac{\sin hx + \sin x}{2 \sin x \cos x + x \cdot 2 \cos 2x + \sin 2x} \\
 &= \lim_{x \rightarrow 0} \frac{\sin hx + \sin x}{2 \sin 2x + 2x \cos 2x} \quad \left[ \frac{0}{0} \right] \text{ form} \\
 &= \lim_{x \rightarrow 0} \frac{\cos hx + \cos x}{4 \cos 2x + 2x (-2 \sin 2x) + 2 \cos 2x} \\
 &= \frac{1+1}{4+0+2} = \frac{2}{6} = \frac{1}{3}.
 \end{aligned}$$

10. Evaluate:  $\lim_{x \rightarrow 0} \frac{e^{2x} - (1+x)^2}{x \log(1+x)}$ .

**Solution**  $L = \lim_{x \rightarrow 0} \frac{e^{2x} - (1+x)^2}{x \log(1+x)} \quad \left[ \frac{0}{0} \right] \text{ form}$

By L' Hospital rule

$$\begin{aligned}
 &= \lim_{x \rightarrow 0} \frac{2e^{2x} - 2(1+x)}{\frac{x}{1+x} + \log(1+x)} \quad \left[ \frac{0}{0} \right] \text{ form} \\
 &= \lim_{x \rightarrow 0} \frac{4e^{2x} - 2}{\frac{1}{(1+x)^2} + \frac{1}{1+x}} = \frac{4-2}{1+1} = 1.
 \end{aligned}$$

11. Evaluate: If  $\lim_{x \rightarrow 0} \frac{x(1 - a \cos x) + b \sin x}{x^3} = \frac{1}{3}$ , find  $a$  and  $b$ .

**Solution**

Given 
$$\frac{1}{3} = \lim_{x \rightarrow 0} \frac{x(1 - a \cos x) + b \sin x}{x^3} \quad \left[ \frac{0}{0} \right] \text{ form}$$

By L' Hospital rule

$$= \lim_{x \rightarrow 0} \frac{1 - a \cos x + x a \sin x + b \cos x}{3x^2}$$

At  $x = 0$ , the numerator =  $1 - a + b$ .

In order that the limit should exist, we must have

$$1 - a + b = 0 \quad \dots(1)$$

Applying L' Hospital rule with this assumption, we get

$$\begin{aligned}
 \frac{1}{3} &= \lim_{x \rightarrow 0} \frac{a \sin x + a(x \cos x + \sin x) - b \sin x}{6x} \quad \left[ \frac{0}{0} \right] \text{ form} \\
 &= \lim_{x \rightarrow 0} \frac{a \cos x + a(-x \sin x + \cos x + \cos x) - b \cos x}{6} \\
 &= \frac{a + 2a - b}{6}
 \end{aligned}$$

$$\frac{1}{3} = \frac{3a - b}{6}$$

Hence,  $3a - b = 2 \quad \dots(2)$

Solving (1) and (2), we get  $a = \frac{1}{2}$ ,  $b = \frac{-1}{2}$ .

12. Evaluate:  $\lim_{x \rightarrow 0} \frac{\log \sin x}{\cot x}$ .

**Solution** 
$$L = \lim_{x \rightarrow 0} \frac{\log \sin x}{\cot x} \quad - \left[ \frac{\infty}{\infty} \right] \text{ form}$$

Since,  $\log 0 = -\infty$ ,  $\cot 0 = \infty$

By L' Hospital rule

$$L = \lim_{x \rightarrow 0} \frac{\cot x}{-\operatorname{cosec}^2 x} \quad \left[ \frac{\infty}{\infty} \right] \text{ form}$$

$$= \lim_{x \rightarrow 0} -\sin x \cdot \cos x = 0.$$

13. Evaluate:  $\lim_{x \rightarrow 0} \frac{\log x}{\operatorname{cosec} x}$ .

**Solution**  $L = \lim_{x \rightarrow 0} \frac{\log x}{\operatorname{cosec} x} \quad \left[ -\frac{\infty}{\infty} \right] \text{ form}$

By L' Hospital rule

$$L = \lim_{x \rightarrow 0} \frac{\frac{1}{x}}{-\operatorname{cosec} x \cot x}$$

$$= \lim_{x \rightarrow 0} \frac{-\sin^2 x}{x \cos x} \quad \left[ \frac{0}{0} \right] \text{ form}$$

$$= \lim_{x \rightarrow 0} \frac{-2 \sin x \cos x}{\cos x - x \sin x} = \frac{0}{1-0} = 0.$$

14. Evaluate:  $\lim_{x \rightarrow \frac{\pi}{2}} \frac{\log \cos x}{\tan x}$ .

**Solution**  $L = \lim_{x \rightarrow \frac{\pi}{2}} \frac{\log \cos x}{\tan x} \quad \left[ -\frac{\infty}{\infty} \right] \text{ form}$

By L' Hospital rule

$$= \lim_{x \rightarrow \frac{\pi}{2}} \frac{-\tan x}{\sec^2 x}$$

$$= \lim_{x \rightarrow \frac{\pi}{2}} -\sin x \cdot \cos x = 0.$$

15. Evaluate:  $\lim_{x \rightarrow 0} \frac{\log \sin ax}{\log \sin bx}$ .

**Solution**  $L = \lim_{x \rightarrow 0} \frac{\log \sin ax}{\log \sin bx} \quad \left[ \frac{-\infty}{-\infty} \right] \text{ form}$

By L' Hospital rule

$$= \lim_{x \rightarrow 0} \frac{a \cos ax / \sin ax}{b \cos bx / \sin bx}$$

$$\begin{aligned}
 &= \lim_{x \rightarrow 0} \frac{a \cot ax}{b \cot bx} && \left[ \frac{\infty}{\infty} \right] \text{ form} \\
 &= \lim_{x \rightarrow 0} \frac{a \tan bx}{b \tan ax} && \left[ \frac{0}{0} \right] \text{ form} \\
 &= \lim_{x \rightarrow 0} \frac{ab \sec^2 bx}{ba \sec^2 ax} = \frac{1}{1} = 1.
 \end{aligned}$$

16. Evaluate:  $\lim_{x \rightarrow a} \frac{\log(x-a)}{\log(e^x - e^a)}$ .

**Solution**  $L = \lim_{x \rightarrow a} \frac{\log(x-a)}{\log(e^x - e^a)}$   $\left[ \frac{\infty}{\infty} \right]$  form

By L' Hospital rule

$$\begin{aligned}
 &= \lim_{x \rightarrow a} \frac{1/(x-a)}{e^x / (e^x - e^a)} \\
 &= \lim_{x \rightarrow a} \frac{e^x - e^a}{(x-a)e^x} && \left[ \frac{0}{0} \right] \text{ form} \\
 &= \lim_{x \rightarrow a} \frac{e^x}{(x-a)e^x + e^x} \\
 &= \lim_{x \rightarrow a} \frac{1}{(x-a) + 1} \\
 &= 1.
 \end{aligned}$$

## EXERCISE 2.1

1. Evaluate:

(i) $\lim_{x \rightarrow 0} \frac{x - \sin x}{\tan^3 x}$	$\left[ \text{Ans. } \frac{1}{6} \right]$	(ii) $\lim_{x \rightarrow 0} \frac{\tan x - x}{x^2 \tan x}$	$\left[ \text{Ans. } \frac{1}{3} \right]$
(iii) $\lim_{x \rightarrow 0} \frac{1 - \cos x}{x \log(1+x)}$	$\left[ \text{Ans. } \frac{1}{2} \right]$	(iv) $\lim_{x \rightarrow 0} \frac{e^x - e^{\sin x}}{x - \sin x}$	$[\text{Ans. } 1]$
(v) $\lim_{x \rightarrow 1} \frac{1 + \log x - x}{(1-x)^2}$	$[\text{Ans. } 1]$	(vi) $\lim_{x \rightarrow 0} \frac{\cos hx - \cos x}{x \sin x}$	$[\text{Ans. } 1]$
(vii) $\lim_{x \rightarrow 0} \frac{e^x - e^{-x} - 2x}{x^2 \sin x}$	$\left[ \text{Ans. } \frac{1}{3} \right]$	(viii) $\lim_{x \rightarrow 0} \frac{x - \log(1+x)}{1 - \cos x}$	$[\text{Ans. } 1]$
(ix) $\lim_{x \rightarrow 1} \frac{x^x - x}{x - 1 - \log x}$	$[\text{Ans. } 2]$	(x) $\lim_{x \rightarrow 0} \frac{\sin x \cdot \sin^{-1} x}{x^2}$	$[\text{Ans. } 1]$

$$(xi) \lim_{x \rightarrow 0} \frac{x^2 + 2 \cos x - 2}{x \sin^3 x} \quad \left[ \text{Ans. } \frac{1}{12} \right] \quad (xii) \lim_{x \rightarrow 0} \frac{\tan^2 x - x^2}{x^2 \tan^2 x} \quad \left[ \text{Ans. } \frac{2}{3} \right]$$

$$(xiii) \lim_{x \rightarrow 0} \frac{e^x + \sin x - 1}{\log(1+x)} \quad \left[ \text{Ans. } 2 \right] \quad (xiv) \lim_{x \rightarrow 0} \frac{e^{3x} + e^{-3x} - 2}{5x^2} \quad \left[ \text{Ans. } \frac{9}{5} \right]$$

2. If  $\lim_{x \rightarrow 0} \frac{\sin 2x + a \sin x}{x^3}$  is finite, find  $a$ . [Ans.  $a = -2$ ]

3. If  $\lim_{x \rightarrow 0} \frac{x(1 + a \cos x) - b \sin x}{x^3} = 1$ , find  $a$  and  $b$ . [Ans.  $a = -\frac{5}{2}$ ,  $b = -\frac{3}{2}$ ]

4. Evaluate:

$$(i) \lim_{x \rightarrow 0} \frac{\log x}{\operatorname{cosec} x} \quad \left[ \text{Ans. } 0 \right] \quad (ii) \lim_{x \rightarrow 0} \frac{\log \sin 2x}{\log \sin x} \quad \left[ \text{Ans. } 1 \right]$$

$$(iii) \lim_{x \rightarrow 0} \frac{\log \tan 2x}{\log \tan x} \quad \left[ \text{Ans. } 1 \right] \quad (iv) \lim_{x \rightarrow \pi/2} \frac{\log \left( x - \frac{\pi}{2} \right)}{\tan x} \quad \left[ \text{Ans. } 0 \right]$$

$$(v) \lim_{x \rightarrow 1} \frac{\log(1-x)}{\cot \pi x} \quad \left[ \text{Ans. } 0 \right] \quad (vi) \lim_{x \rightarrow \infty} \frac{x^2}{e^{x^2}} \quad \left[ \text{Ans. } 0 \right]$$

### 2.1.2 Indeterminate Forms $\infty - \infty$ and $0 \times \infty$

L' Hospital rule can be applied to limits which take the indeterminate forms  $\infty - \infty$  and  $0 \times \infty$ . First we transform the given limit in the form  $\frac{0}{0}$  or  $\frac{\infty}{\infty}$  and then by use L'Hospital rule to evaluate the limit.

#### WORKED OUT EXAMPLES

1. Evaluate:  $\lim_{x \rightarrow 0} \left[ \frac{1}{x} - \frac{\log(1+x)}{x^2} \right]$ .

**Solution**  $L = \lim_{x \rightarrow 0} \left[ \frac{1}{x} - \frac{\log(1+x)}{x^2} \right] \quad \left[ \infty - \infty \right] \text{ form}$

Hence, required limit  $L = \lim_{x \rightarrow 0} \frac{x - \log(1+x)}{x^2} \quad \left[ \frac{0}{0} \right] \text{ form}$

By L' Hospital rule  $= \lim_{x \rightarrow 0} \frac{1 - \frac{1}{1+x}}{2x}$

$$= \lim_{x \rightarrow 0} \frac{x}{1+x} \cdot \frac{1}{2x} = \lim_{x \rightarrow 0} \frac{1}{2(1+x)}$$

$$= \lim_{x \rightarrow 0} \frac{1}{2(1+x)}$$

$$= \frac{1}{2}.$$

2. Evaluate:  $\lim_{x \rightarrow 0} \left\{ \frac{1}{x} - \cot x \right\}$ .

**Solution**

Hence, we have  $L = \lim_{x \rightarrow 0} \left\{ \frac{1}{x} - \cot x \right\}$   $[\infty - \infty]$  form

$$L = \lim_{x \rightarrow 0} \left\{ \frac{1}{x} - \frac{\cos x}{\sin x} \right\}$$

$$= \lim_{x \rightarrow 0} \frac{\sin x - x \cos x}{x \sin x}$$
  $\left[ \frac{0}{0} \right]$  form

By L' Hospital rule  $= \lim_{x \rightarrow 0} \frac{\cos x - \cos x + x \sin x}{x \cos x + \sin x}$

$$= \lim_{x \rightarrow 0} \frac{x \sin x}{x \cos x + \sin x}$$
  $\left[ \frac{0}{0} \right]$  form

$$= \lim_{x \rightarrow 0} \frac{x \cos x + \sin x}{\cos x - x \sin x + \cos x}$$

$$= \frac{0}{2-0} = \frac{0}{2} = 0.$$

3. Evaluate:  $\lim_{x \rightarrow 0} x \log \tan x$ .

**Solution**

$$L = \lim_{x \rightarrow 0} x \log \tan x$$
  $[0 \times (-\infty)]$  form

Hence, we have  $= \lim_{x \rightarrow 0} \frac{\log \tan x}{\frac{1}{x}}$   $\left[ -\frac{\infty}{\infty} \right]$  form

Applying L' Hospital rule  $= \lim_{x \rightarrow 0} \frac{\frac{\sec^2 x}{\tan x}}{\frac{-1}{x^2}}$

$$= \lim_{x \rightarrow 0} - \frac{x^2 \sec^2 x}{\tan x}$$
  $\left[ \frac{0}{0} \right]$  form

$$= \lim_{x \rightarrow 0} - \left[ \frac{2x \sec^2 x + x^2 \cdot 2 \sec^2 x \tan x}{\sec^2 x} \right]$$

$$= \lim_{x \rightarrow 0} - [2x + 2x^2 \tan x] = 0.$$

4. Evaluate:  $\lim_{x \rightarrow 0} \tan x \log x$ .

**Solution**

$$L = \lim_{x \rightarrow 0} \tan x \log x \quad [0 \times (-\infty)] \text{ form}$$

$$= \lim_{x \rightarrow 0} \frac{\log x}{\cot x} \quad \left[-\frac{\infty}{\infty}\right] \text{ form}$$

By L' Hospital rule

$$= \lim_{x \rightarrow 0} \frac{\frac{1}{x}}{-\operatorname{cosec}^2 x}$$

$$= \lim_{x \rightarrow 0} \frac{-\sin^2 x}{x} \quad \left[\frac{0}{0}\right] \text{ form}$$

$$= \lim_{x \rightarrow 0} \frac{-2 \sin x \cos x}{1} = 0.$$

5. Evaluate:  $\lim_{x \rightarrow 0} \left[ \frac{1}{x^2} - \frac{1}{\sin^2 x} \right]$ .

**Solution**

$$L = \lim_{x \rightarrow 0} \left[ \frac{1}{x^2} - \frac{1}{\sin^2 x} \right] \quad [\infty - \infty] \text{ form}$$

$$= \lim_{x \rightarrow 0} \frac{\sin^2 x - x^2}{x^2 \sin^2 x} \quad \left[\frac{0}{0}\right] \text{ form}$$

$$= \lim_{x \rightarrow 0} \frac{\sin^2 x - x^2}{x^4} \times \frac{x^2}{\sin^2 x}$$

$$= \lim_{x \rightarrow 0} \frac{\sin^2 x - x^2}{x^4} \times \lim_{x \rightarrow 0} \frac{x^2}{\sin^2 x}$$

$$\left( \lim_{x \rightarrow 0} \frac{\sin x}{x} = 1 \therefore \lim_{x \rightarrow 0} \frac{x}{\sin x} = 1 \right)$$

$$= \lim_{x \rightarrow 0} \frac{\sin^2 x - x^2}{x^4} \quad \left[\frac{0}{0}\right] \text{ form}$$

By applying L' Hospital rule

$$= \lim_{x \rightarrow 0} \frac{2 \sin x \cos x - 2x}{4x^3}$$

$$= \lim_{x \rightarrow 0} \frac{\sin 2x - 2x}{4x^3} \quad \left[\frac{0}{0}\right] \text{ form}$$

$$= \lim_{x \rightarrow 0} \frac{2 \cos 2x - 2}{12x^2}$$

$$= \lim_{x \rightarrow 0} \frac{\cos 2x - 1}{6x^2} \quad (\because 1 - \cos 2x = 2 \sin^2 x)$$

$$= \lim_{x \rightarrow 0} \frac{-2 \sin^2 x}{6x^2}$$



$$\begin{aligned}
&= \lim_{x \rightarrow 0} -\frac{1}{3} \left( \frac{\sin x}{x} \right)^2 \\
&= -\frac{1}{3} \lim_{x \rightarrow 0} \left( \frac{\sin x}{x} \right)^2 \\
&= -\frac{1}{3} \times 1 \\
&= -\frac{1}{3}.
\end{aligned}$$

6. Evaluate:  $\lim_{x \rightarrow 0} \left[ \frac{1}{x^2} - \cot^2 x \right]$ .

**Solution**  $L = \lim_{x \rightarrow 0} \left( \frac{1}{x^2} - \cot^2 x \right)$  [ $\infty - \infty$ ] form

$$= \lim_{x \rightarrow 0} \left( \frac{1}{x^2} - \frac{\cos^2 x}{\sin^2 x} \right)$$

$$= \lim_{x \rightarrow 0} \frac{\sin^2 x - x^2 \cos^2 x}{x^2 \sin^2 x}$$
 [ $\frac{0}{0}$ ] form

$$= \lim_{x \rightarrow 0} \frac{\sin^2 x - x^2 \cos^2 x}{x^4} \times \frac{x^2}{\sin^2 x}$$

$$= \lim_{x \rightarrow 0} \frac{\sin^2 x - x^2 \cos^2 x}{x^4} \times \lim_{x \rightarrow 0} \frac{x^2}{\sin^2 x}$$
 ( $\lim_{x \rightarrow 0} \frac{\sin x}{x} = 1$ )

$$= \lim_{x \rightarrow 0} \frac{\sin^2 x - x^2 \cos^2 x}{x^4}$$

$$\therefore \sin^2 x - x^2 \cos^2 x = \sin^2 x - x^2 (1 - \sin^2 x)$$

$$= (1 + x^2) \sin^2 x - x^2$$

$$= \lim_{x \rightarrow 0} \frac{(1 + x^2) \sin^2 x - x^2}{x^4}$$
 [ $\frac{0}{0}$ ] form

By L' Hospital rule

$$= \lim_{x \rightarrow 0} \frac{(1 + x^2) \cdot 2 \sin x \cos x + 2x \sin^2 x - 2x}{4x^3}$$

$$= \lim_{x \rightarrow 0} \frac{(1 + x^2) \sin 2x + 2x \sin^2 x - 2x}{4x^3}$$
 [ $\frac{0}{0}$ ] form

Again by L' Hospital rule

$$= \lim_{x \rightarrow 0} \frac{(1 + x^2) \cdot 2 \cos 2x + 2x \sin 2x + 4x \sin x \cos x + 2 \sin^2 x - 2}{12x^2}$$

$$\begin{aligned}
&= \lim_{x \rightarrow 0} \frac{2(1+x^2)(1-2\sin^2 x) + 4x \sin 2x + 2\sin^2 x - 2}{12x^2} \\
&= \lim_{x \rightarrow 0} \frac{2x^2 - 2\sin^2 x - 4x^2 \sin^2 x + 4x \sin 2x}{12x^2} \\
&= \lim_{x \rightarrow 0} \frac{2 - 2 \times \left(\frac{\sin x}{x}\right)^2 - 4\sin^2 x + 4 \times \left(\frac{\sin 2x}{x}\right)}{12} \\
&= \lim_{x \rightarrow 0} \frac{2 - 2 \times \left(\frac{\sin x}{x}\right)^2 - 4\sin^2 x + 4 \times 2 \times \left(\frac{\sin 2x}{2x}\right)}{12} \\
&= \frac{2 - 2 - 0 + 8}{12} = \frac{8}{12} = \frac{2}{3}.
\end{aligned}$$

7. Evaluate:  $\lim_{x \rightarrow \frac{\pi}{4}} (1 - \tan x) \sec 2x$ .

**Solution**  $L = \lim_{x \rightarrow \frac{\pi}{4}} (1 - \tan x) \sec 2x$  [0 × ∞] form

$$= \lim_{x \rightarrow \frac{\pi}{4}} \frac{1 - \tan x}{\cos 2x} \quad \left[ \frac{0}{0} \right] \text{ form}$$

By L' Hospital rule

$$= \lim_{x \rightarrow \frac{\pi}{4}} \frac{-\sec^2 x}{-2 \sin 2x} = \frac{-2}{-2} = 1.$$

8. Evaluate:  $\lim_{x \rightarrow a} \log \left( 2 - \frac{x}{a} \right) \cot(x - a)$ .

**Solution**  $L = \lim_{x \rightarrow a} \log \left( 2 - \frac{x}{a} \right) \cot(x - a)$  [0 × ∞] form

$$= \lim_{x \rightarrow a} \frac{\log \left( 2 - \frac{x}{a} \right)}{\tan(x - a)} \quad \left[ \frac{0}{0} \right] \text{ form}$$

By L' Hospital rule

$$= \lim_{x \rightarrow a} \frac{\frac{1}{\left( 2 - \frac{x}{a} \right)} \times \left( -\frac{1}{a} \right)}{\sec^2(x - a)}$$

$$= \frac{\left( -\frac{1}{a} \right)}{1} = \frac{-1}{a}.$$

## EXERCISES 2.2

Evaluate the following:

- |  |                          |  |           |
|--|--------------------------|--|-----------|
| 1. $\lim_{x \rightarrow 1} \left( \frac{x}{x-1} - \frac{1}{\log x} \right)$ .    | [Ans. $\frac{1}{2}$ ]    | 2. $\lim_{x \rightarrow 0} \left( \frac{1}{\sin x} - \frac{1}{x} \right)$ .      | [Ans. 0]  |
| 3. $\lim_{x \rightarrow 0} \left( \frac{a}{x} - \cos \frac{x}{a} \right)$ .      | [Ans. 0]                 | 4. $\lim_{x \rightarrow 0} (\operatorname{cosec} x - \cot x)$ .                  | [Ans. 0]  |
| 5. $\lim_{x \rightarrow \pi/2} (\sec x - \tan x)$ .                              | [Ans. 0]                 | 6. $\lim_{x \rightarrow 1} \left( \frac{1}{\log x} - \frac{x}{\log x} \right)$ . | [Ans. -1] |
| 7. $\lim_{x \rightarrow \pi/2} \left( x \tan x - \frac{\pi}{2} \sec x \right)$ . | [Ans. -1]                | 8. $\lim_{x \rightarrow 0} x^3 \log x$ .   | [Ans. 0]  |
| 9. $\lim_{x \rightarrow 1} \sec \left( \frac{\pi}{2} x \right) \times \log x$ .  | [Ans. $-\frac{2}{\pi}$ ] |  |           |

### 2.1.3 Indeterminate Forms $0^0$ , $1^\infty$ , $\infty^0$ , $0^\infty$

Let  $L = \lim_{x \rightarrow a} \{f(x)\}^{g(x)}$ . If  $L$  takes one of the indeterminate forms  $0^0$ ,  $1^\infty$ ,  $\infty^0$ ,  $0^\infty$  then taking logarithm on both sides, we get

$$\log L = \lim_{x \rightarrow a} g(x) \log f(x)$$

Then,  $\log L$  will take the indeterminate form  $0 \times \infty$  and which can be evaluated by using the method employed in preceding section.

## WORKED OUT EXAMPLES

1. Evaluate:  $\lim_{x \rightarrow 0} (1 + \sin x)^{\cot x}$ .

**Solution**  $L = \lim_{x \rightarrow 0} (1 + \sin x)^{\cot x}$  [ $1^\infty$ ] form

Taking logarithm on both sides

$$\begin{aligned} \log L &= \lim_{x \rightarrow 0} \cot x \log (1 + \sin x) && [\infty \times 0] \text{ form} \\ &= \lim_{x \rightarrow 0} \frac{\log (1 + \sin x)}{\tan x} && \left[ \frac{0}{0} \right] \text{ form} \end{aligned}$$

By L' Hospital rule

$$\begin{aligned} &= \lim_{x \rightarrow 0} \frac{\cos x / 1 + \sin x}{\sec^2 x} \\ \log L &= \lim_{x \rightarrow 0} \frac{\cos x}{\sec^2 x (1 + \sin x)} = \frac{1}{1(1+0)} = 1 \end{aligned}$$

$$\therefore L = e^1 = e.$$

2. Evaluate:  $\lim_{x \rightarrow \frac{\pi}{4}} (\tan x)^{\tan 2x}$ .

**Solution**  $L = \lim_{x \rightarrow \frac{\pi}{4}} (\tan x)^{\tan 2x}$  ( $1^\infty$ ) form

Taking logarithm on both sides

$$\log L = \lim_{x \rightarrow \frac{\pi}{4}} \tan 2x \log (\tan x) \quad [\infty \times 0] \text{ form}$$

$$= \lim_{x \rightarrow \frac{\pi}{4}} \frac{\log \tan x}{\cot 2x} \quad \left[ \frac{0}{0} \right] \text{ form}$$

By L' Hospital rule

$$= \lim_{x \rightarrow \frac{\pi}{4}} \frac{\sec^2 x / \tan x}{-2 \operatorname{cosec}^2 2x}$$

$$= \lim_{x \rightarrow \frac{\pi}{4}} \frac{-\sec^2 x}{2 \tan x \operatorname{cosec}^2 2x}$$

$$= \frac{-(\sqrt{2})^2}{2 \cdot 1 \cdot 1^2}$$

$$\log L = -1$$

$$L = e^{-1}$$

$$= \frac{1}{e}$$

3. Evaluate:  $\lim_{x \rightarrow 0} \left( \frac{\tan x}{x} \right)^{\frac{1}{x^2}}$ .

**Solution**  $L = \lim_{x \rightarrow 0} \left( \frac{\tan x}{x} \right)^{\frac{1}{x^2}}$  ( $1^\infty$ ) form

(Since,  $\lim_{x \rightarrow 0} \frac{\tan x}{x} = 1$  as  $x \rightarrow 0$ )

Taking logarithm on both sides

$$\log L = \lim_{x \rightarrow 0} \frac{1}{x^2} \log \frac{\tan x}{x} \quad [\infty \times 0] \text{ form}$$

$$= \lim_{x \rightarrow 0} \frac{\log \frac{\tan x}{x}}{x^2} \quad \left[ \frac{0}{0} \right] \text{ form}$$

By L' Hospital rule

$$= \lim_{x \rightarrow 0} \frac{\frac{1}{\tan x} \cdot \left[ \frac{x \sec^2 x - \tan x}{x^2} \right]}{2x}$$

$$\begin{aligned}
&= \lim_{x \rightarrow 0} \frac{x \sec^2 x - \tan x}{2x^2 \tan x} && \left[ \frac{0}{0} \right] \text{ form} \\
&= \lim_{x \rightarrow 0} \frac{\sec^2 x + 2x \sec^2 x \tan x - \sec^2 x}{2[x^2 \sec^2 x + 2x \tan x]} \\
&= \lim_{x \rightarrow 0} \frac{\sec^2 x \tan x}{x \sec^2 x + 2 \tan x} && \left[ \frac{0}{0} \right] \text{ form}
\end{aligned}$$

Again By L' Hospital Rule

$$\log L = \lim_{x \rightarrow 0} \frac{\sec^2 x \sec^2 x + \tan x \cdot 2 \sec^2 x \tan x}{\sec^2 x + x(2 \sec^2 x \tan x) + 2 \sec^2 x} = \frac{1}{3}$$

$$\therefore L = e^{1/3}.$$

4. Evaluate:  $\lim_{x \rightarrow \infty} (1 + x^2)^{e^{-x}}$ .

**Solution** 
$$L = \lim_{x \rightarrow \infty} (1 + x^2)^{e^{-x}} \quad \left( \begin{array}{l} \because e^{-\infty} = 0, \\ 1 + \infty = \infty \end{array} \right) [\infty^0] \text{ form}$$

Taking log on both sides

$$\begin{aligned}
\log L &= \lim_{x \rightarrow \infty} e^{-x} \log (1 + x^2) && [0 \times \infty] \text{ form} \\
&= \lim_{x \rightarrow \infty} \frac{\log (1 + x^2)}{e^x} && \left[ \frac{\infty}{\infty} \right] \text{ form}
\end{aligned}$$

By L' Hospital rule

$$\begin{aligned}
&= \lim_{x \rightarrow \infty} \frac{2x/(1+x^2)}{e^x} \\
&= \lim_{x \rightarrow \infty} \frac{2x}{(1+x^2)e^x} && \left[ \frac{\infty}{\infty} \right] \text{ form} \\
&= \lim_{x \rightarrow \infty} \frac{2}{(1+x^2)e^x + 2xe^x}
\end{aligned}$$

$$\begin{aligned}
\log L &= 0 \\
L &= e^0 = 1.
\end{aligned}$$

5. Evaluate:  $\lim_{x \rightarrow \frac{\pi}{2}} (\sec x)^{\cot x}$ .

**Solution** 
$$L = \lim_{x \rightarrow \frac{\pi}{2}} (\sec x)^{\cot x} \quad [\infty^0] \text{ form}$$

$$\log L = \lim_{x \rightarrow \frac{\pi}{2}} \cot x \log \sec x \quad [0 \times \infty] \text{ form}$$

$$= \lim_{x \rightarrow \frac{\pi}{2}} \frac{\log \sec x}{\tan x} \quad \left[ \frac{\infty}{\infty} \right] \text{ form}$$

By L' Hospital rule

$$= \lim_{x \rightarrow \frac{\pi}{2}} \frac{\sec x \cdot \tan x}{\sec^2 x}$$

$$= \lim_{x \rightarrow \frac{\pi}{2}} \frac{\tan x}{\sec^2 x}$$

$$\log L = \lim_{x \rightarrow \frac{\pi}{2}} \sin x \cos x = 0$$

$$\therefore L = e^0 = 1$$

### EXERCISE 2.3

Evaluate:

- |   |                       |  |                        |
|---|-----------------------|--|------------------------|
| 1. $\lim_{x \rightarrow 0} (\cos x)^{\frac{1}{x^2}}$                        | [Ans. $e^{-1/2}$ ]    | 2. $\lim_{x \rightarrow \frac{\pi}{2}} (\sin x)^{\tan x}$                                | [Ans. 1]               |
| 3. $\lim_{x \rightarrow 0} \left(\frac{1}{x}\right)^{\tan x}$               | [Ans. 1]              | 4. $\lim_{x \rightarrow 0} x^x$  | [Ans. 1]               |
| 5. $\lim_{x \rightarrow 0} \left(\frac{\sin x}{x}\right)^{\frac{1}{x}}$     | [Ans. 1]              | 6. $\lim_{x \rightarrow 0} (\cos ax)^{\frac{b}{x^2}}$                                    | [Ans. $e^{-a^2 b/2}$ ] |
| 7. $\lim_{x \rightarrow 1} x^{\frac{1}{(1-x)}}$                             | [Ans. $\frac{1}{e}$ ] | 8. $\lim_{x \rightarrow 0} x^{\sin x}$   | [Ans. 1]               |
| 9. $\lim_{x \rightarrow 1} (1-x^2)^{\frac{1}{\log(1-x)}}$                   | [Ans. $e$ ]           | 10. $\lim_{x \rightarrow 1} (2-x)^{\tan \frac{\pi x}{2}}$                                | [Ans. $e^{2/\pi}$ ]    |
| 11. $\lim_{x \rightarrow 0} (\cos^2 x)^{\frac{1}{x^2}}$                     | [Ans. $\frac{1}{e}$ ] | 12. $\lim_{x \rightarrow 0} \left(\frac{\sin hx}{x}\right)^{\frac{1}{x^2}}$              | [Ans. $\frac{1}{6}$ ]  |
| 13. $\lim_{x \rightarrow 0} x^{\log x}$                                     | [Ans. $e$ ]           | 14. $\lim_{x \rightarrow 0} \left(\frac{1}{x}\right)^{2 \sin x}$                         | [Ans. 1]               |
| 15. $\lim_{x \rightarrow 0} \left[\frac{a^x + b^x}{2}\right]^{\frac{1}{x}}$ | [Ans. $\sqrt{ab}$ ]   | 16. $\lim_{x \rightarrow \infty} \left[\frac{\pi}{2} - \tan^{-1} x\right]^{\frac{1}{x}}$ | [Ans. 1]               |

## 2.2 TAYLOR'S THEOREM FOR FUNCTIONS OF TWO VARIABLES

**Statement:** If  $f(x, y)$  has continuous partial derivatives up to  $n$ th order in a neighbourhood of a point  $(a, b)$ , then

$$f(a+h, b+k) = f(a, b) + \left[ h \frac{\partial}{\partial x} + k \frac{\partial}{\partial y} \right] f(a, b) + \frac{1}{2!} \left[ h \frac{\partial}{\partial x} + k \frac{\partial}{\partial y} \right]^2 f(a, b) \\ + \frac{1}{3!} \left[ h \frac{\partial}{\partial x} + k \frac{\partial}{\partial y} \right]^3 f(a, b) + \dots + \frac{1}{(n-1)!} \left[ h \frac{\partial}{\partial x} + k \frac{\partial}{\partial y} \right]^{n-1} f(a, b) + R_n \quad \dots(1)$$

where  $R_n = \frac{1}{n!} \left[ h \frac{\partial}{\partial x} + k \frac{\partial}{\partial y} \right]^n f(a + \theta h, b + \theta k)$  for some  $\theta : 0 < \theta < 1$ .

Here,  $R_n$  is called the remainder after  $n$  times.

By the Taylor's theorem given in

$$f(x, y) = f(a, b) + \frac{1}{1!} [(x-a)f_x(a, b) + (y-b)f_y(a, b)] \\ + \frac{1}{2!} [(x-a)^2 f_{xx}(a, b) + 2(x-a)(y-b)f_{xy}(a, b) + (y-b)^2 f_{yy}(a, b)] + \dots \quad \dots(2)$$

This is called the Taylor's expansion of  $f(x, y)$  about the point  $(a, b)$ . If  $a = 0$  and  $b = 0$ , we get the Maclaurin's form of Taylor's theorem.

$$\text{i.e., } f(x, y) = f(0, 0) + \frac{1}{1!} [x f_x(0, 0) + y f_y(0, 0)] \\ + \frac{1}{2!} [x^2 f_{xx}(0, 0) + 2xy f_{xy}(0, 0) + y^2 f_{yy}(0, 0)] + \dots \quad \dots(3)$$

Further, if the Taylor's series of  $f(x, y)$  is approximated to some terms up to a particular degree the resulting expression of  $f(x, y)$  is called as the Taylor's polynomial.

### WORKED OUT EXAMPLES

1. Expand  $e^x \sin y$  by using Maclaurin's theorem up to the third degree terms.

**Solution**

Let  $f(x, y) = e^x \sin y$

Now

$$\begin{array}{ll} f_x = e^x \sin y & f_y = e^x \cos y \\ f_{xx} = e^x \sin y & f_{yy} = -e^x \sin y \\ f_{xy} = e^x \cos y & f_{xyy} = -e^x \sin y \\ f_{xxx} = e^x \sin y & f_{yyy} = -e^x \cos y \\ f_{xxy} = e^x \cos y & \end{array}$$

At (0, 0)

$$\begin{aligned} f(0, 0) &= 0 & f_x(0, 0) &= 0 & f_y(0, 0) &= 1 \\ f_{xx}(0, 0) &= 0 & f_{xy}(0, 0) &= 1 & f_{yy}(0, 0) &= 0 \\ f_{xxx}(0, 0) &= 0 & f_{xxy}(0, 0) &= 1 & f_{xyy}(0, 0) &= 0 \\ f_{yyy}(0, 0) &= -1 \end{aligned}$$

Hence, by Maclaurin's theorem

$$\begin{aligned} f(x, y) &= f(0, 0) + [x f_x(0, 0) + y f_y(0, 0)] \\ &+ \frac{1}{2!} [x^2 f_{xx}(0, 0) + 2xy f_{xy}(0, 0) + y^2 f_{yy}(0, 0)] \\ &+ \frac{1}{3!} [x^3 f_{xxx}(0, 0) + 3x^2 y f_{xxy}(0, 0) + 3xy^2 f_{xyy}(0, 0) + y^3 f_{yyy}(0, 0)] + \dots \end{aligned}$$

Substituting all the values in the expansion of  $f(x, y)$ , we get

$$\begin{aligned} e^x \sin y &= 0 + [x \cdot 0 + y \cdot 1] + \frac{1}{2!} [x^2 \cdot 0 + 2xy \cdot 1 + y^2 \cdot 0] \\ &+ \frac{1}{3!} [x^3 \cdot 0 + 3x^2 y + 3xy^2 \cdot 0 + y^3(-1)] + \dots \\ e^x \sin y &= y + xy + \frac{x^2 y}{2} - \frac{y^3}{6} + \dots \end{aligned}$$

2. Expand  $e^x \log(1 + y)$  by Maclaurin's theorem up to the third degree term.

**Solution**

Let  $f(x, y) = e^x \log(1 + y)$

The function and its partial derivatives evaluated at (0, 0) is as follows:

$$\begin{aligned} f(x, y) &= e^x \log(1 + y) & \rightarrow & 0 \\ f_x &= e^x \log(1 + y) & \rightarrow & 0 \\ f_y &= e^x \cdot 1/(1 + y) & \rightarrow & 1 \\ f_{xx} &= e^x \log(1 + y) & \rightarrow & 0 \\ f_{xy} &= e^x/1 + y & \rightarrow & 1 \\ f_{yy} &= -e^x/(1 + y)^2 & \rightarrow & -1 \\ f_{xxx} &= e^x \log(1 + y) & \rightarrow & 0 \\ f_{xxy} &= e^x/(1 + y) & \rightarrow & 1 \\ f_{xyy} &= -e^x/(1 + y)^2 & \rightarrow & -1 \\ f_{yyy} &= 2e^x/(1 + y)^3 & \rightarrow & 2 \end{aligned}$$

∴ By Maclaurin's theorem

$$\begin{aligned} f(x, y) &= f(0, 0) + [x f_x(0, 0) + y f_y(0, 0)] + \frac{1}{2!} [x^2 f_{xx}(0, 0) + 2xy f_{xy}(0, 0) + y^2 f_{yy}(0, 0)] \\ &+ \frac{1}{3!} [x^3 f_{xxx}(0, 0) + 3x^2 y f_{xxy}(0, 0) + 3xy^2 f_{xyy}(0, 0) + y^3 f_{yyy}(0, 0)] + \dots \end{aligned}$$



Substituting all the values in the expansion of  $f(x, y)$ , we get

$$e^x \log(1 + y) = y + \frac{1}{2}(2xy - y^2) + \frac{1}{6}(3x^2y - 3xy^2 + 2y^3).$$

3. Expand  $e^{ax + by}$  by using Maclaurin's theorem up to the third term.

**Solution.** Since the expansions required in powers of  $x, y$  the point  $(a, b)$  associated is  $(0, 0)$  and the expansion of  $f(x, y)$  about  $(0, 0)$  is given by

$$\begin{aligned} f(x, y) = & f(0, 0) + [x f_{xx}(0, 0) + y f_{yy}(0, 0)] + \frac{1}{2!} [x^2 f_{xx}(0, 0) \\ & + 2xy f_{xy}(0, 0) + y^2 f_{yy}(0, 0)] + \frac{1}{3!} [x^3 f_{xxx}(0, 0) \\ & + 3x^2 y f_{xxy}(0, 0) + 3xy^2 f_{xyy}(0, 0) + y^3 f_{yyy}(0, 0)] + \dots \end{aligned}$$

The functions and its partial derivatives evaluated at  $(0, 0)$  is as follows:

$$\begin{aligned} f(x, y) = e^{ax + by} & \rightarrow 1 \\ f_x = ae^{ax + by} & \rightarrow a \\ f_y = be^{ax + by} & \rightarrow b \\ f_{xx} = a^2 e^{ax + by} & \rightarrow a^2 \\ f_{xy} = abe^{ax + by} & \rightarrow ab \\ f_{yy} = b^2 e^{ax + by} & \rightarrow b^2 \\ f_{yyy} = b^3 e^{ax + by} & \rightarrow b^3 \\ f_{xxx} = a^3 e^{ax + by} & \rightarrow a^3 \\ f_{xyy} = ab^2 e^{ax + by} & \rightarrow ab^2 \\ f_{xxy} = a^2 b e^{ax + by} & \rightarrow a^2 b \end{aligned}$$

Substituting these values in the expansion of  $f(x, y)$ , we get

$$f(x, y) = 1 + (ax + by) + \frac{(ax + by)^2}{2!} + \frac{(ax + by)^3}{3!} + \dots$$

4. Expand  $\tan^{-1} y/x$  about the point  $(1, 1)$  using Taylor's theorem up to the second degree terms.

**Solution.** The expansion of  $f(x, y)$  about  $(1, 1)$  is given by

$$\begin{aligned} f(x, y) = & f(1, 1) + [(x - 1) f_x(1, 1) + (y - 1) f_y(1, 1)] \\ & + \frac{1}{2!} [(x - 1)^2 f_{xx}(1, 1) + 2(x - 1)(y - 1) f_{xy}(1, 1) + (y - 1)^2 f_{yy}(1, 1)] \\ & + \frac{1}{3!} [(x - 1)^3 f_{xxx}(1, 1) + 3(x - 1)^2 (y - 1) f_{xxy}(1, 1) + 3(x - 1)(y - 1)^2 f_{xyy}(1, 1) \\ & + (y - 1)^3 f_{yyy}(1, 1)] + \dots \end{aligned}$$

$$\begin{aligned}
 \text{Let } f(x, y) &= \tan^{-1} \frac{y}{x} & ; & \quad f(1, 1) = \tan^{-1}(1) = \frac{\pi}{4} \\
 f_x &= \frac{1}{1 + \frac{y^2}{x^2}} \cdot \frac{-y}{x^2} = \frac{-y}{x^2 + y^2} & ; & \quad f_x(1, 1) = \frac{-1}{2} \\
 f_y &= \frac{1}{1 + \frac{y^2}{x^2}} \cdot \frac{1}{x} = \frac{x}{x^2 + y^2} & ; & \quad f_y(1, 1) = \frac{1}{2} \\
 f_{xx} &= \frac{2xy}{(x^2 + y^2)^2} & ; & \quad f_{xx}(1, 1) = \frac{1}{2} \\
 f_{yy} &= \frac{-2xy}{(x^2 + y^2)^2} & ; & \quad f_{yy}(1, 1) = \frac{-1}{2} \\
 f_{xy} &= \frac{(x^2 + y^2) \cdot 1 - x \cdot 2x}{(x^2 + y^2)^2} = \frac{y^2 - x^2}{(x^2 + y^2)^2} & ; & \quad f_{xy}(1, 1) = 0
 \end{aligned}$$

Substituting these values in the expansion of  $f(x, y)$ , we get

$$\tan^{-1} \frac{y}{x} = \frac{\pi}{4} + \frac{1}{2} [-(x-1) + (y-1)] + \frac{1}{2!} \left[ \frac{1}{2}(x-1)^2 - \frac{1}{2}(y-1)^2 \right] + \dots$$

5. Expand  $e^x \cos y$  by Taylor's theorem about the point  $\left(1, \frac{\pi}{4}\right)$  up to the second degree terms.

**Solution.** The expansion of  $f(x, y)$  about  $\left(1, \frac{\pi}{4}\right)$  is given by

$$\begin{aligned}
 f(x, y) &= f\left(1, \frac{\pi}{4}\right) + \left[ (x-1)f_x\left(1, \frac{\pi}{4}\right) + \left(y - \frac{\pi}{4}\right)f_y\left(1, \frac{\pi}{4}\right) \right] \\
 &+ \frac{1}{2!} \left[ (x-1)^2 f_{xx}\left(1, \frac{\pi}{4}\right) + 2(x-1)\left(y - \frac{\pi}{4}\right)f_{xy}\left(1, \frac{\pi}{4}\right) \right. \\
 &\left. + \left(y - \frac{\pi}{4}\right)^2 f_{yy}\left(1, \frac{\pi}{4}\right) + \dots \right]
 \end{aligned}$$

The function and its partial derivatives are evaluated at  $\left(1, \frac{\pi}{4}\right)$ .

$$\begin{aligned}
 f(x, y) &= e^x \cos y & \rightarrow & \quad \frac{e}{\sqrt{2}} \\
 f_x &= e^x \cos y & \rightarrow & \quad \frac{e}{\sqrt{2}} \\
 f_y &= -e^x \sin y & \rightarrow & \quad \frac{-e}{\sqrt{2}}
 \end{aligned}$$

$$f_{xx} = e^x \cos y \rightarrow \frac{e}{\sqrt{2}}$$

$$f_{xy} = -e^x \sin y \rightarrow \frac{-e}{\sqrt{2}}$$

$$f_{yy} = -e^x \cos y \rightarrow \frac{-e}{\sqrt{2}}$$

Substituting these values in the expansions of  $f(x, y)$ , we get

$$e^x \cos y = \frac{e}{\sqrt{2}} \left\{ 1 + \left[ (x-1) - \left( y - \frac{\pi}{4} \right) \right] + \frac{1}{2} \left[ (x-1)^2 - 2(x-1) \left( y - \frac{\pi}{4} \right) - \left( y - \frac{\pi}{4} \right)^2 \right] \right\}.$$

### EXERCISE 2.4

1. Expand  $x^2y$  about the point  $(1, -2)$  by Taylor's theorem.

$$\left[ \text{Ans. } -2 - 4(x-1) + (y+2) + \frac{1}{2!} \left[ -4(x-1)^2 + 4(x-1)(y+2) \right] \right]$$

2. Expand  $x^2y + 3y - 4$  about the point  $(1, -2)$  by Taylor's theorem.

$$\left[ \text{Ans. } -12 - 4(x-1) + 4(y+2) - 2(x-1)^2 + 2(x-1)(y+2) + (x-1)^2(y+2) \right]$$

3. Expand  $e^{xy}$  about the point  $(1, 1)$  by using Taylor's theorem up to second degree terms.

$$\left[ \text{Ans. } e \left\{ 1 + (x-1) + (y-1) + \frac{1}{2!} \left[ (x-1)^2 + 4(x-1)(y-1) + (y-1)^2 \right] + \dots \right\} \right]$$

4. Obtain the Taylor's expansion of  $e^x \sin y$  about the point  $\left(0, \frac{\pi}{2}\right)$  up to second degree terms.

$$\left[ \text{Ans. } 1 + x + \frac{1}{2!} \left[ x^2 - \left( y - \frac{\pi}{2} \right)^2 \right] + \dots \right]$$

5. Expand  $\tan^{-1} \frac{y}{x}$  about the point  $(1, 2)$  using Taylor's theorem up to second degree terms:

$$\left[ \text{Ans. } \tan^{-1} 2 + \frac{1}{5} \left[ -2(x-1) + (y-2) \right] + \frac{1}{50} \left[ 4(x-1)^2 - 6(x-1)(y-2) - 4(y-2)^2 \right] \right]$$

6. Obtain the Maclaurin's expansion of the following functions:

(i)  $e^{xy}$  up to second degree terms.  $\left[ \text{Ans. } 1 + xy + \frac{1}{2} x^2 y^2 + \dots \right]$

(ii)  $\log(1-x-y)$  up to 3rd degree terms.  $\left[ \text{Ans. } (x-y) - \frac{1}{2}(x-y)^2 + \frac{1}{3}(x-y)^3 + \dots \right]$

(iii)  $e^{ax} \sin by$  up to 3rd degree terms.  $\left[ \text{Ans. } by + abxy + \frac{1}{6}(3a^2bx^2y - b^3y^3) + \dots \right]$

(iv) $\sin(x + y)$ up to 3rd degree terms.	$\left[ \text{Ans. } (x + y) - \frac{(x + y)^3}{3!} + \dots \right]$
(v) $\cos(ax + by)$ up to 2nd degree terms.	$\left[ \text{Ans. } 1 - \frac{(ax + by)^2}{2!} + \dots \right]$

## 2.3 MAXIMA AND MINIMA OF FUNCTIONS OF TWO VARIABLES

### Maximum Value of a Function

A function  $f(x, y)$  is said to have a maximum at a point  $(a, b)$ , if there exists a neighbourhood  $N$  of  $(a, b)$  such that

$$f(x, y) < f(a, b) \text{ for all } (x, y) \in N.$$

### Minimum Value of a Function

A function  $f(x, y)$  is said to have a minimum at  $(a, b)$ , if there exists a neighbourhood  $N$  of  $(a, b)$  such that

$$f(x, y) > f(a, b) \text{ for all } (x, y) \in N.$$

#### 2.3.1 Necessary and Sufficient Conditions for Maxima and Minima

The necessary conditions for a function  $f(x, y)$  to have either a maximum or a minimum at a point  $(a, b)$  are  $f_x(a, b) = 0$  and  $f_y(a, b) = 0$ .

The points  $(x, y)$  where  $x$  and  $y$  satisfy  $f_x(x, y) = 0$  and  $f_y(x, y) = 0$  are called the stationary or the critical values of the function.

Suppose  $(a, b)$  is a critical value of the function  $f(x, y)$ . Then  $f_x(a, b) = 0, f_y(a, b) = 0$ .

Now denote

$$f_{xx}(a, b) = A, \quad f_{xy}(a, b) = B, \quad f_{yy}(a, b) = C$$

1. Then, the function  $f(x, y)$  has a maximum at  $(a, b)$  if  $AC - B^2 > 0$  and  $A < 0$ .

2. The function  $f(x, y)$  has a minimum at  $(a, b)$  if  $AC - B^2 > 0$  and  $A > 0$ .

Maximum and minimum values of a function are called the “**extreme values of the function**”.

#### Working rule to find the maximum and minimum value of a function $f(x, y)$

1. Find  $f_x(x, y)$  and  $f_y(x, y)$ .

2. Solve the equations  $f_x(x, y) = 0$  and  $f_y(x, y) = 0$ .

Let  $(a, b)$  be a root of the above equations. Here  $(a, b)$  is called the critical point.

3. Then find  $f_{xx}(x, y), f_{xy}(x, y), f_{yy}(x, y)$ .

4. Then  $A = f_{xx}(a, b), B = f_{xy}(a, b), C = f_{yy}(a, b)$ .

5. If  $AC - B^2 > 0$  and  $A < 0$ , then  $f$  has a maximum at  $(a, b)$ .

6. If  $AC - B^2 > 0$  and  $A > 0$ , then  $f$  has a minimum at  $(a, b)$ .

7. If  $AC - B^2 < 0$ , then  $f$  has neither a maximum nor a minimum at  $(a, b)$ . The point  $(a, b)$  is called the **'Saddle point'**.
8. If  $AC - B^2 = 0$ , further investigation is necessary.

### WORKED OUT EXAMPLES

1. Find the extreme values of the function  $2xy - 5x^2 - 2y^2 + 4x + 4y - 6$ .

**Solution**

Let  $f(x, y) = 2xy - 5x^2 - 2y^2 + 4x + 4y - 6$

Now  $f_x = 2y - 10x + 4$

$$f_y = 2x - 4y + 4$$

Now  $f_x = 0$  and  $f_y = 0$  implies

$$2y - 10x + 4 = 0 \quad \text{and} \quad 2x - 4y + 4 = 0$$

i.e.,  $5x - y - 2 = 0$  and  $x - 2y + 2 = 0$

Solving, we get  $x = \frac{2}{3}$ ,  $y = \frac{4}{3}$

$\therefore$  The critical point of  $f$  is  $\left(\frac{2}{3}, \frac{4}{3}\right)$

Now  $A = f_{xx} = -10$ ,  $B = f_{xy} = 2$

$$C = f_{yy} = -4$$

and  $AC - B^2 = (-10)(-4) - (+2)^2 = 36 > 0$

and  $A = -10 < 0$

$\therefore f$  attains its maximum at  $\left(\frac{2}{3}, \frac{4}{3}\right)$

$$\begin{aligned} \text{Also maximum } f(x, y) &= f\left(\frac{2}{3}, \frac{4}{3}\right) = 2 \cdot \frac{2}{3} \cdot \frac{4}{3} - 5 \cdot \frac{4}{9} - 2 \cdot \frac{16}{9} + 4 \cdot \frac{2}{3} + 4 \cdot \frac{4}{3} - 6, \\ &= -2. \end{aligned}$$

2. Find the extreme values of the function  $x^3y^2(1 - x - y)$ .

**Solution**

Let  $f(x, y) = x^3y^2(1 - x - y)$

i.e.,  $f(x, y) = x^3y^2 - x^4y^2 - x^3y^3$

Now  $f_x = 3x^2y^2 - 4x^3y^2 - 3x^2y^3$

$$f_y = 2x^3y - 2x^4y - 3x^3y^2$$

Then  $f_x = 0$  and  $f_y = 0$

$$3x^2y^2 - 4x^3y^2 - 3x^2y^3 = 0 \quad \text{and} \quad 2x^3y - 2x^4y - 3x^3y^2 = 0$$

$$\begin{aligned}
 \text{i.e., } x^2y^2(3 - 4x - 3y) &= 0 & \text{and} & & x^3y(2 - 2x - 3y) &= 0 \\
 \therefore x = 0 \text{ or } y = 0 & \text{or} & & & 4x + 3y = 3 & \text{and} \\
 x = 0 \text{ or } y = 0 & \text{or} & & & 2x + 3y = 2 & \\
 \text{Solving } 4x + 3y = 3 & \text{and} & & & 2x + 3y = 2 &
 \end{aligned}$$

we get 
$$x = \frac{1}{2}, \quad y = \frac{1}{3}$$

Hence, the critical points are  $(0, 0)$  and  $\left(\frac{1}{2}, \frac{1}{3}\right)$

$$\begin{aligned}
 \text{Further, } A = f_{xx} &= 6xy^2 - 12x^2y^2 - 6xy^3 \\
 &= 6xy^2(1 - 2x - y) \\
 B = f_{xy} &= 6x^2y - 8x^3y - 9x^2y^2 \\
 &= x^2y(6 - 8x - 9y) \\
 C = f_{yy} &= 2x^3 - 2x^4 - 4x^3y \\
 &= 2x^3(1 - x - 3y)
 \end{aligned}$$

(i) At the point  $(0, 0)$ ,  $A = 0$ ,  $B = 0$ ,  $C = 0$ ,  $AC - B^2 = 0$  and further investigation is required.

(ii) At the point  $\left(\frac{1}{2}, \frac{1}{3}\right)$   $A = -\frac{1}{9}$ ,  $B = \frac{-1}{12}$ ,  $C = \frac{-1}{8}$

$$\text{Now } AC - B^2 = \left(\frac{-1}{9}\right)\left(\frac{-1}{8}\right) - \left(\frac{-1}{12}\right)^2 = \frac{1}{144} > 0$$

and 
$$A = \frac{-1}{9} < 0$$

$\therefore f(x, y)$  attains its maximum at  $\left(\frac{1}{2}, \frac{1}{3}\right)$

$$\begin{aligned}
 \text{Maximum } f(x, y) &= f\left(\frac{1}{2}, \frac{1}{3}\right) = \frac{1}{8} \cdot \frac{1}{9} \left(1 - \frac{1}{2} - \frac{1}{3}\right) \\
 &= \frac{1}{432}.
 \end{aligned}$$

**3. Find the extreme values of the function  $x^3 + y^3 - 3xy$ .**

**Solution**

Let 
$$f(x, y) = x^3 + y^3 - 3xy$$

We have 
$$f_x = 3x^2 - 3y$$

$$f_y = 3y^2 - 3x$$

Now 
$$f_x = 0 \quad \text{and} \quad f_y = 0 \text{ implies}$$

$$\Rightarrow x^2 - y = 0 \quad \text{and} \quad y^2 - x = 0$$

i.e., 
$$x^2 = y \quad \text{and} \quad x = y^2$$

Eliminating  $y$ , we get

$$\begin{aligned}
 & x = (x^2)^2 \quad \text{or} \quad x = x^4 \\
 \text{or} & \quad \quad \quad x - x^4 = 0 \\
 & \quad \quad \quad x(1 - x^3) = 0 \\
 \Rightarrow & \quad \quad \quad x = 0, x = 1 \\
 & \quad \quad \quad \text{if } x = 0, \quad \text{then} \quad y = 0 \\
 \text{and} & \quad \quad \quad \text{if } x = 1 \quad \text{then} \quad y = 1
 \end{aligned}$$

$\therefore$  The critical points are  $(0, 0)$  and  $(1, 1)$

Further,

$$\begin{aligned}
 A &= f_{xx} = 6x, \\
 B &= f_{xy} = -3 \\
 C &= f_{yy} = 6y
 \end{aligned}$$

At  $(0, 0)$ ,  $A = 0, B = -3, C = 0$

So that  $AC - B^2 = 0 - 9 < 0$

Hence, there is neither a maximum nor minimum at  $(0, 0)$

*i.e.*,  $(0, 0)$  is a saddle point.

At  $(1, 1)$ ,  $A = 6, B = -3, C = 6$

and  $AC - B^2 = 6 \cdot 6 - (-3)^2 = 36 - 9 = 27 > 0$

and  $A = 6 > 0$

Hence,  $f(x, y)$  attains its minimum value at  $(1, 1)$

Also, minimum,  $f(x, y) = f(1, 1) = 1^3 + 1^3 - 3 \cdot 1 \cdot 1 = -1$ .

**4. Find the extreme values of the function  $x^4 + 2x^2y - x^2 + 3y^2$ .**

**Solution**

Let  $f(x, y) = x^4 + 2x^2y - x^2 + 3y^2$

We have  $f_x = 4x^3 + 4xy - 2x$

and  $f_y = 2x^2 + 6y$

Then  $f_x = 0$  and  $f_y = 0$  implies

$$2x(2x^2 + 2y - 1) = 0 \text{ and } 2(x^2 + 3y) = 0$$

*i.e.*,  $x = 0$  or  $2x^2 + 2y - 1 = 0$  and  $x^2 + 3y = 0$

which is same as

$$\{x = 0 \text{ and } x^2 + 3y = 0\} \text{ or } \{2x^2 + 2y - 1 = 0 \text{ and } x^2 + 3y = 0\}$$

*i.e.*,  $x = 0$  and  $y = 0$ .

where  $x^2 = -3y$

$$\therefore 2x^2 + 2y - 1 = 0$$

$$2(-3y) + 2y - 1 = 0$$

which implies  $y = \frac{-1}{4}$

Hence,  $x^2 = \frac{3}{4}$  or  $x = \pm \frac{\sqrt{3}}{2}$

Hence, the critical values are  $(0, 0)$ ,  $\left(\frac{\sqrt{3}}{2}, \frac{-1}{4}\right)$  and  $\left(\frac{-\sqrt{3}}{2}, \frac{-1}{4}\right)$

Further

$$A = f_{xx} = 12x^2 + 4y - 2, B = f_{xy} = 4x, C = f_{yy} = 6$$

(i) At  $(0, 0)$ ,  $A = -2$ ,  $B = 0$ ,  $C = 6$  and  $AC - B^2 = -12 < 0$

Hence, there is neither a maximum nor a minimum at  $(0, 0)$

(ii) At  $\left(\frac{\sqrt{3}}{2}, \frac{-1}{4}\right)$ ,  $A = 12 \cdot \frac{3}{4} + 4 \left(\frac{-1}{4}\right) - 2 = 6$

$$B = 4 \cdot \frac{\sqrt{3}}{2} = 2\sqrt{3}, C = 6$$

Then,  $AC - B^2 = 6(6) - (2\sqrt{3})^2 = 24 > 0$  and

$$A = 6 > 0$$

$\therefore f(x, y)$  has a minimum at  $\left(\frac{\sqrt{3}}{2}, \frac{-1}{4}\right)$

Hence,  $f(x, y)$  attains its minimum value at  $\left(\frac{\sqrt{3}}{2}, \frac{-1}{4}\right)$

Also, minimum  $f(x, y) = \left(\frac{-3}{8}\right)$

(iii) Similarly, at  $\left(\frac{-\sqrt{3}}{2}, \frac{-1}{4}\right)$

$f(x, y)$  attains its minimum.

Thus,  $f(x, y)$  attains minimum  $\frac{-3}{8}$  at  $\left(\pm \frac{\sqrt{3}}{2}, \frac{-1}{4}\right)$ .

**5. Determine the maxima/minima of the function**

$$\sin x + \sin y + \sin(x + y).$$

**Solution**

Let  $f(x, y) = \sin x + \sin y + \sin(x + y)$

We have  $f_x = \cos x + \cos(x + y)$

$$f_y = \cos y + \cos(x + y)$$

Now  $f_x = 0$  and  $f_y = 0$  implies

$$\cos(x + y) = -\cos x \text{ and } \cos(x + y) = -\cos y$$

i.e.,  $-\cos x = -\cos y$  or  $\cos x = \cos y$

or  $x = y$

Then,  $\cos 2x = -\cos x = \cos(\pi - x)$



or 
$$2x = \pi - x \text{ or } x = \frac{\pi}{3}$$

So that 
$$y = \frac{\pi}{3}$$

The critical point is  $\left(\frac{\pi}{3}, \frac{\pi}{3}\right)$

Further, 
$$A = f_{xx} = -\sin x - \sin(x + y)$$

$$B = f_{xy} = -\sin(x + y)$$

$$C = f_{yy} = -\sin y - \sin(x + y)$$

At  $\left(\frac{\pi}{3}, \frac{\pi}{3}\right)$ , 
$$A = -\sin \frac{\pi}{3} - \sin \frac{2\pi}{3} = -\frac{\sqrt{3}}{2} - \frac{\sqrt{3}}{2} = -\sqrt{3}$$

$$B = -\sin \frac{2\pi}{3} = -\frac{\sqrt{3}}{2}$$

$$C = -\sin \frac{\pi}{3} - \sin \frac{2\pi}{3} = -\frac{\sqrt{3}}{2} - \frac{\sqrt{3}}{2} = -\sqrt{3}$$

and 
$$AC - B^2 = (-\sqrt{3})(-\sqrt{3}) - \left(-\frac{\sqrt{3}}{2}\right)^2 = \frac{9}{4} > 0$$

Also 
$$A = -\sqrt{3} < 0$$

$\therefore f(x, y)$  attains its maximum at  $\left(\frac{\pi}{3}, \frac{\pi}{3}\right)$

and maximum  $f(x, y) = f\left(\frac{\pi}{3}, \frac{\pi}{3}\right) = \sin \frac{\pi}{3} + \sin \frac{\pi}{3} + \sin\left(\frac{2\pi}{3}\right)$   

$$= \frac{\sqrt{3}}{2} + \frac{\sqrt{3}}{2} + \frac{\sqrt{3}}{2} = \frac{3\sqrt{3}}{2}.$$

**6. Examine the function  $f(x, y) = 1 + \sin(x^2 + y^2)$  for extreme.**

**Solution** 
$$f(x, y) = 1 + \sin(x^2 + y^2)$$

$$f_x = 2x \cos(x^2 + y^2)$$

$$f_y = 2y \cos(x^2 + y^2)$$

Now 
$$f_x = 0 \text{ and } f_y = 0 \text{ implies}$$

i.e., 
$$2x \cos(x^2 + y^2) = 0 \text{ and } 2y \cos(x^2 + y^2) = 0$$

$\therefore$  
$$x = 0, y = 0 \text{ and } (0, 0) \text{ is the stationary point.}$$

$$A = f_{xx} = -4x^2 \sin(x^2 + y^2) + 2 \cos(x^2 + y^2)$$

$$B = f_{xy} = -4xy \sin(x^2 + y^2)$$

$$C = f_{yy} = -4y^2 \sin(x^2 + y^2) + 2 \cos(x^2 + y^2)$$

At  $(0, 0)$ ; 
$$A = 2, B = 0, C = 2$$

$$\therefore AC - B^2 = 4 > 0$$

Since,  $AC - B^2 > 0$ ,  $A = 2 > 0$ ,  $(0, 0)$  is minimum point and the minimum value of  $f(x, y) = f(0, 0) = 1$ .

## EXERCISE 2.5

Find the extreme values of the following functions:

1.  $x^2 - xy + y^2 + 3x - 2y + 1$

$$\left[ \text{Ans. Min.} = \frac{-4}{3} \text{ at } \left( \frac{-4}{3}, \frac{1}{3} \right) \right]$$

2.  $x^2 + xy + y^2 + 3x - 3y + 4$

$$\left[ \text{Ans. Min.} = -5 \text{ at } (-3, 3) \right]$$

3.  $x^2 + 2y^2 - 4x + 4y + 6$

$$\left[ \text{Ans. Min.} = 0 \text{ at } (2, -1) \right]$$

4.  $x^3 + 3xy^2 - 15x^2 - 15y^2 + 72x$

$$\left[ \text{Ans. Max.} = 112 \text{ at } (4, 0) \right]$$

5.  $x^3 + y^3 - 63(x + y) + 12xy$

$$\left[ \begin{array}{l} \text{Ans. Max.} = 784 \text{ at } (-7, -7) \\ \text{Min.} = -216 \text{ at } (3, 3) \end{array} \right]$$

6.  $x^2y^2(12 - 3x - 4y)$

$$\left[ \text{Ans. Max.} = 8 \text{ at } (2, 1) \right]$$

7.  $x^3 - y^3 - 3y^2$

$$\left[ \text{Ans. Max.} = 0 \text{ at } (3\sqrt{4}, -2) \right]$$

8.  $xy(a - x - y)$ , where  $a > 0$

$$\left[ \text{Ans. Max.} = \frac{a^3}{27} \text{ at } \left( \frac{a}{3}, \frac{a}{3} \right) \right]$$

9.  $x^2y(x + 2y - 4)$

$$\left[ \text{Ans. Min.} = -2 \text{ at } \left( 2, \frac{1}{2} \right) \right]$$

10.  $2x^3 + xy^2 + 5x^2 + y^2$

$$\left[ \begin{array}{l} \text{Ans. Min.} = 0 \text{ at } (0, 0) \\ \text{Max.} = \frac{125}{7} \text{ at } \left( -\frac{5}{3}, 0 \right) \\ \text{and } (-1, 2), (-1, -2) \text{ are saddle points} \end{array} \right]$$

11.  $x^4 + y^4 - (x + y)^4$

$$\left[ \text{Ans. Min.} = -14 \text{ and } 2 \text{ at } (1, 1) \text{ and } (-1, 1) \right]$$

12.  $x^2 + xy + y^2 + x + y$

$$\left[ \text{Ans. Min.} = -\frac{1}{3} \text{ at } \left( -\frac{1}{3}, -\frac{1}{3} \right) \right]$$

## 2.4 LAGRANGE'S METHOD OF UNDETERMINED MULTIPLIERS

So far, we have considered the method of finding the extreme values of a function  $f(x, y, z)$ , where these variables  $x, y, z$  are independent. Sometimes we may have to find the maximum or minimum

values of a function  $f(x, y, z)$ , when  $x, y, z$  are connected by some relations say  $\phi(x, y, z) = 0$ . In such cases we may eliminate  $z$  from the given conditions and express the function  $f(x, y, z)$  as a function of two variables  $x$  and  $y$  and obtain the extreme values of  $f$  as before. In such cases we have an alternative method for finding the critical points called “Lagrange’s method of undetermined multipliers”.

Suppose we want to find the maximum or minimum values of the function

$$\mu = f(x, y, z) \quad \dots(1)$$

Subject to the condition

$$\phi(x, y, z) = 0 \quad \dots(2)$$

Then,

$$d\mu = f_x dx + f_y dy + f_z dz$$

and

$$d\phi = \phi_x dx + \phi_y dy + \phi_z dz = 0$$

But the necessary conditions for the function  $f(x, y, z)$  to have a maximum or a minimum values are  $f_x = 0, f_y = 0, f_z = 0$ .

$$\text{Hence, } f_x dx + f_y dy + f_z dz = 0 \quad \dots(3)$$

and

$$\phi_x dx + \phi_y dy + \phi_z dz = 0 \quad \dots(4)$$

Multiplying (4) by  $\lambda$  and adding it to (3), we get

$$(f_x + \lambda \phi_x) dx + (f_y + \lambda \phi_y) dy + (f_z + \lambda \phi_z) dz = 0$$

This is possible only if

$$f_x + \lambda \phi_x = 0 \quad \dots(5)$$

$$f_y + \lambda \phi_y = 0 \quad \dots(6)$$

$$f_z + \lambda \phi_z = 0 \quad \dots(7)$$

Solving the equations (2), (5), (6) and (7), we get the values of  $x, y, z$  and the undetermined multipliers  $\lambda$ . Thus, we obtain the critical points of the function  $f(x, y, z)$ .

But this method does not help us in identifying whether the critical points of the function gives the maximum or minimum.

### Working Rules

To find the extreme values of the function  $f(x, y, z)$  subject to the conditions  $\phi(x, y, z) = 0$

1. Form the auxiliary equation

$$F(x, y, z, \lambda) = f(x, y, z) + \lambda \phi(x, y, z)$$

2. Find the critical points of  $F$  as a function of four variables  $x, y, z, \lambda$ . i.e., solving the equations  $F_x = 0, F_y = 0, F_z = 0$  and  $F_\lambda = \phi = 0$ , we get

$$\lambda = -\frac{f_x}{\phi_x} = -\frac{f_y}{\phi_y} = -\frac{f_z}{\phi_z}$$

The values of  $x, y, z$  thus obtained will give us the critical point  $(x, y, z)$ .

### WORKED OUT EXAMPLES

1. Find the minimum value of  $x^2 + y^2 + z^2$  subject to the condition  $ax + by + cz = p$ .

**Solution**

Let  $F = (x^2 + y^2 + z^2) + \lambda (ax + by + cz)$

We form the equations  $F_x = 0, F_y = 0, F_z = 0$

i.e.,  $2x + \lambda a = 0, 2y + \lambda b = 0, 2z + \lambda c = 0$

or  $\lambda = \frac{-2x}{a}, \lambda = \frac{-2y}{b}, \lambda = \frac{-2z}{c}$

$\Rightarrow \frac{-2x}{a} = \frac{-2y}{b} = \frac{-2z}{c}$

or  $\frac{x}{a} = \frac{y}{b} = \frac{z}{c} = k$  (say)

$\therefore x = ak, y = bk, z = ck$

But  $ax + by + cz = p$  and hence, we have

$$a^2k + b^2k + c^2k = p$$

$\therefore k = \frac{p}{a^2 + b^2 + c^2}$

Hence, the required minimum value of  $x^2 + y^2 + z^2$  is

$$a^2k^2 + b^2k^2 + c^2k^2 = k^2 (a^2 + b^2 + c^2)$$

i.e.,  $\frac{p^2 (a^2 + b^2 + c^2)}{(a^2 + b^2 + c^2)^2} = \frac{p^2}{a^2 + b^2 + c^2}$

thus, the required minimum value is  $\frac{p^2}{a^2 + b^2 + c^2}$ .

2. The temperature  $T$  at any point  $(x, y, z)$  in space is  $T = 400xyz^2$ . Find the highest temperature at the surface of the unit sphere  $x^2 + y^2 + z^2 = 1$ .

**Solution**

Let  $F = 400xyz^2 + \lambda (x^2 + y^2 + z^2)$

We form the equations  $F_x = 0, F_y = 0, F_z = 0$

i.e.,  $400yz^2 + \lambda \cdot 2x = 0$  or  $\lambda = \frac{-200yz^2}{x}$

$400xz^2 + \lambda \cdot 2y = 0$  or  $\lambda = \frac{-200xz^2}{y}$

$800xyz + \lambda \cdot 2z = 0$  or  $\lambda = -400xy$

Now,  $\frac{-200yz^2}{x} = \frac{-200xz^2}{y} = -400xy$

Taking the equality pairs, we get

$$\frac{y}{x} = \frac{x}{y}, z^2 = 2y^2, z^2 = 2x^2$$

*i.e.*,  $y^2 = x^2$  or  $y = x$  also  $z = \sqrt{2}x$   
But  $x^2 + y^2 + z^2 = 1$  and hence, we have

$$x^2 + x^2 + 2x^2 = 1 \text{ i.e., } 4x^2 = 1 \text{ or } x = \frac{1}{2}$$

$\therefore$   $x = \frac{1}{2}, y = \frac{1}{2}, z = \frac{1}{\sqrt{2}}$  is a stationary point.

The maximum (height) temperature

$$\begin{aligned} T &= 400 xyz^2 \text{ is} \\ &= 400 \left(\frac{1}{2}\right) \left(\frac{1}{2}\right) \left(\frac{1}{\sqrt{2}}\right) = 50. \end{aligned}$$

**3.** If  $\frac{1}{x} + \frac{1}{y} + \frac{1}{z} = 1$ , show that the minimum value of the function  $a^3x^2 + b^3y^2 + c^3z^2$  is  $(a + b + c)^3$ .

**Solution**

$$\text{Let } F = (a^3x^2 + b^3y^2 + c^3z^2) + \lambda \left(\frac{1}{x} + \frac{1}{y} + \frac{1}{z}\right)$$

we form the equations  $F_x = 0, F_y = 0, F_z = 0$

$$\text{i.e., } 2a^3x + \lambda \left(\frac{-1}{x^2}\right) = 0 \text{ or } \lambda = 2a^3x^3$$

$$2b^3y + \lambda \left(\frac{-1}{y^2}\right) = 0 \text{ or } \lambda = 2b^3y^3$$

$$2c^3z + \lambda \left(\frac{-1}{z^2}\right) = 0 \text{ or } \lambda = 2c^3z^3$$

$$\text{Now } 2a^3x^3 = 2b^3y^3 = 2c^3z^3$$

$$\Rightarrow a^3x^3 = b^3y^3 = c^3z^3$$

$$\Rightarrow ax = by = cz$$

$$\therefore y = \frac{ax}{b}, z = \frac{ax}{c}$$

$$\text{But } \frac{1}{x} + \frac{1}{y} + \frac{1}{z} = 1 \text{ i.e., } \frac{1}{x} + \frac{b}{ax} + \frac{c}{ax} = 1$$

$$\frac{a+b+c}{ax} = 1$$

$$\therefore x = \frac{a+b+c}{a}$$

Also 
$$y = \frac{a+b+c}{b}, \quad z = \frac{a+b+c}{c}$$

Required minimum value of the function  $a^3x^2 + b^3y^2 + c^3z^2$  is given by

$$\begin{aligned} &= a^3 \cdot \left(\frac{a+b+c}{a}\right)^2 + b^3 \left(\frac{a+b+c}{b}\right)^2 + c^3 \left(\frac{a+b+c}{c}\right)^2 \\ &= (a+b+c)^2 (a+b+c) = (a+b+c)^3 \end{aligned}$$

Thus, the required minimum value is  $(a+b+c)^3$ .

**4.** Find the minimum value of  $x^2 + y^2 + z^2$ , when  $x + y + z = 3a$ .

**Solution**

Let 
$$F = (x^2 + y^2 + z^2) + \lambda (x + y + z)$$

We form the equations  $F_x = 0, F_y = 0, F_z = 0$

i.e., 
$$2x + \lambda = 0, 2y + \lambda = 0, 2z + \lambda = 0$$

or 
$$\lambda = -2x, \lambda = -2y, \lambda = -2z$$

$\Rightarrow -2x = -2y = -2z$  or  $x = y = z$

But 
$$x + y + z = 3a$$

Substituting  $y = z = x$ , we get  $3x = 3a$

$$x = a$$

$\therefore x = a, y = a, z = a$

The required minimum value of  $x^2 + y^2 + z^2$  is  $a^2 + a^2 + a^2 = 3a^2$ .

**5.** Find the minimum value of  $x^2 + y^2 + z^2$  subject to the conditions  $xy + yz + zx = 3a^2$ .

[July 2003]

**Solution**

Let 
$$F = (x^2 + y^2 + z^2) + \lambda (xy + yz + zx) = 0$$

We form the equations  $F_x = 0, F_y = 0, F_z = 0$

i.e., 
$$2x + \lambda (y + z) = 0, 2y + \lambda (x + z) = 0, 2z + \lambda (x + y) = 0$$

$\Rightarrow \lambda = \frac{-2x}{y+z}, \lambda = \frac{-2y}{x+z}, \lambda = \frac{-2z}{x+y}$ .

Equating the R.H.S. of these, we have

$$\frac{2x}{y+z} = \frac{2y}{x+z} = \frac{2z}{x+y} \quad \dots(1)$$

Consider,

$$\frac{x}{y+z} = \frac{y}{x+z}$$

i.e., 
$$x^2 + xz = y^2 + yz$$
 or  $(x^2 - y^2) + z(x - y) = 0$

or 
$$(x - y)(x + y + z) = 0$$

$\Rightarrow x = y$  or  $x + y + z = 0$

we must have  $x = y$ , since  $x + y + z$  cannot be zero.

Suppose  $x + y + z = 0$ , then by squaring, we get

$$(x^2 + y^2 + z^2) + 2(xy + yz + zx) = 0$$

$$\Rightarrow x^2 + y^2 + z^2 + 2(3a^2) = 0$$

or  $x^2 + y^2 + z^2 = -6a^2 < 0$

which is not possible. Similarly by equating the other two pairs in (1), we get

$$y = z, z = x \text{ thus } x = y = z$$

But  $xy + yz + zx = 3a^2$ , putting  $y = z = x$ , we get

$$3x^2 = 3a^2 \Rightarrow x = a$$

Thus,  $x = a = y = z$  and the minimum value of  $x^2 + y^2 + z^2$  is

$$a^2 + a^2 + a^2 = 3a^2.$$

### EXERCISE 2.6

1. Find the minimum value of  $x^2 + y^2 + z^2$  subject to the condition  $xyz = a^3$ . [Ans.  $3a^2$ ]

2. Find the maximum and minimum values of  $x^2 + y^2$  subject to the conditions

$$5x^2 + 6xy + 5y^2 = 8.$$

[Ans. 4 and 1]

3. Find the maximum value of  $x^2 y^2 z^2$  subject to the condition  $x^2 + y^2 + z^2 = a^2$ .

$$\left[ \text{Ans.} \left( \frac{a^2}{3} \right)^3 \right]$$

4. Find the minimum value of  $x^2 + y^2 + z^2$  subject to the conditions

(i)  $xy + yz + zx = 3a^2$

[Ans.  $3a^2$ ]

(ii)  $xyz = a^3$

[Ans.  $3a^2$ ]

(iii)  $ax + by + cz = P$ .

$$\left[ \text{Ans.} \frac{P^2}{a^2 + b^2 + c^2} \right]$$

### ADDITIONAL PROBLEMS (From Previous Years VTU Exams.)

1. Evaluate:

(i)  $\lim_{x \rightarrow 0} \left( \frac{a^x + b^x + c^x}{3} \right)^{\frac{1}{x}}$

(ii)  $\lim_{x \rightarrow \frac{\pi}{2}} (2x \tan x - \pi \sec x)$ .

**Solution**

$$(i) \lim_{x \rightarrow 0} \left( \frac{a^x + b^x + c^x}{3} \right)^{\frac{1}{x}}$$

[1<sup>∞</sup>] form

$$\text{Let } K = \lim_{x \rightarrow 0} \left( \frac{a^x + b^x + c^x}{3} \right)^{\frac{1}{x}}$$

Taking logarithm on both sides

$$\log K = \lim_{x \rightarrow 0} \frac{1}{x} \log \left( \frac{a^x + b^x + c^x}{3} \right)$$

Apply L' Hospital rule

$$= \lim_{x \rightarrow 0} \left\{ \frac{\left( \frac{3}{a^x + b^x + c^x} \right) \left( \frac{a^x \log a + b^x \log b + c^x \log c}{3} \right)}{1} \right\}$$

$$= \frac{3}{3} \times \left( \frac{\log a + \log b + \log c}{3} \right)$$

$$\log K = \frac{1}{3} \log (abc)$$

$$\log K = \log (abc)^{\frac{1}{3}}$$

$$K = (abc)^{\frac{1}{3}}$$

$$\text{i.e., } \lim_{x \rightarrow 0} \left( \frac{a^x + b^x + c^x}{3} \right)^{\frac{1}{x}} = (abc)^{\frac{1}{3}}.$$

(ii) Let

$$K = \lim_{x \rightarrow \frac{\pi}{2}} (2x \tan x - \pi \sec x) \quad [\infty - \infty] \text{ form}$$

$$= \lim_{x \rightarrow \frac{\pi}{2}} \left[ 2x \cdot \frac{\sin x}{\cos x} - \pi \cdot \frac{1}{\cos x} \right]$$

$$= \lim_{x \rightarrow \frac{\pi}{2}} \left[ \frac{2x \sin x - \pi}{\cos x} \right] \quad \left[ \frac{0}{0} \right] \text{ form}$$

Applying L' Hospital rule

$$K = \lim_{x \rightarrow \frac{\pi}{2}} \left[ \frac{2x \cos x + 2 \cos x}{-\sin x} \right] = -2.$$



2. Evaluate:  $\lim_{x \rightarrow \frac{\pi}{4}} (\tan x)^{\tan 2x}$ .

**Solution.** Refer page no. 75. Example 2.

3. Evaluate:

(i)  $\lim_{x \rightarrow 0} \left[ \frac{1}{x^2} - \frac{1}{\sin^2 x} \right]$

(ii)  $\lim_{x \rightarrow \frac{\pi}{2}} (\sin x)^{\tan x}$ .

**Solution.** (i) Refer page 61. Example 5.

(ii)  $\lim_{x \rightarrow \frac{\pi}{2}} (\sin x)^{\tan x}$

$[1^\infty]$  form

Let  $K = \lim_{x \rightarrow \frac{\pi}{2}} (\sin x)^{\tan x}$

$$\log K = \lim_{x \rightarrow \frac{\pi}{2}} \{ \tan x \log \sin x \}$$

$$= \lim_{x \rightarrow \frac{\pi}{2}} \left[ \frac{\log \sin x}{\cot x} \right]$$

$\left[ \frac{0}{0} \right]$  form

Apply L' Hospital rule

$$= \lim_{x \rightarrow \frac{\pi}{2}} \left[ \frac{\frac{1}{\sin x} \cdot \cos x}{-\operatorname{cosec}^2 x} \right]$$

$$= \lim_{x \rightarrow \frac{\pi}{2}} \left[ \frac{-\cos x \times \sin^2 x}{\sin x} \right]$$

$$\log K = 0$$

$$K = e^0 = 1$$

i.e.,  $\lim_{x \rightarrow \frac{\pi}{2}} (\sin x)^{\tan x} = 1$ .

4. Find the value of  $a$  and  $b$  such that  $\lim_{x \rightarrow 0} \left[ \frac{x(1 + a \cos x) - b \sin x}{x^3} \right] = 1$ .

**Solution.** Consider  $\lim_{x \rightarrow 0} \left[ \frac{x(1 + a \cos x) - b \sin x}{x^3} \right]$

$\left[ \frac{0}{0} \right]$  form

Applying L' Hospital rule, we have

$$= \lim_{x \rightarrow 0} \frac{x(-a \sin x) + (1 + a \cos x) - b \cos x}{3x^2}$$

This is equal to  $\frac{1+a-b}{0}$  and we must have

$$1 + a - b = 0 \quad \dots(1)$$

To apply the L' Hospital rule again. Hence, we have

$$= \lim_{x \rightarrow 0} \left[ \frac{x(-a \cos x) - 2a \sin x + b \sin x}{6x} \right] \quad \left[ \frac{0}{0} \right] \text{ form}$$

Applying the L' Hospital rule again, we have

$$= \lim_{x \rightarrow 0} \frac{x(a \sin x) - 3a \cos x + b \cos x}{6}$$

This is equal to  $\frac{-3a+b}{6}$  which must be equal to 1

$$\therefore -3a + b = 6 \quad \dots(2)$$

Solving (1) and (2), we get

$$a = \frac{-5}{2} \quad \text{and} \quad b = \frac{-3}{2}.$$

5. Evaluate:  $\lim_{x \rightarrow \frac{\pi}{2}} \frac{\log(\cos x)}{\tan x}$ .

**Solution.** Refer page no. 67, Example 14.

6. Find the maximum and minimum distances of the function  $x^4 + 2x^2y - x^2 + 3y^2$ .

**Solution.** Refer page no. 86, Example 4.

7. Expand  $e^{ax+by}$  in the neighbourhood of the origin up to the third degree term.

**Solution.** Refer page no. 80, Example 3.

8. Expand  $\log(1+x-y)$  up to third degree terms about the origin.

**Solution.** By Maclaurin's series

$$f(x, y) = f(0, 0) + [x f_x(0, 0) + y f_y(0, 0)] + \frac{1}{2!} \{x^2 f_{xx}(0, 0) + 2xy f_{xy}(0, 0) + y^2 f_{yy}(0, 0)\} + \dots$$

Here,  $f(x, y) = \log(1+x-y) \Rightarrow f(0, 0) = \log 1 = 0$

$$f_x = \frac{1}{1+x-y} \Rightarrow f_x(0, 0) = 1$$

$$f_y = \frac{-1}{1+x-y} \Rightarrow f_y(0, 0) = -1$$

$$f_{xx} = \frac{-1}{(1+x-y)^2} \Rightarrow f_{xx}(0, 0) = -1$$

$$\begin{aligned}
 f_{xy} &= \frac{1}{(1+x-y)^2} & \Rightarrow f_{xy}(0, 0) &= 1 \\
 f_{yy} &= \frac{-1}{(1+x-y)^2} & \Rightarrow f_{yy}(0, 0) &= -1 \\
 f_{xxx} &= \frac{2}{(1+x-y)^3} & \Rightarrow f_{xxx}(0, 0) &= 2 \\
 f_{xxy} &= \frac{-2}{(1+x-y)^3} & \Rightarrow f_{xxy}(0, 0) &= -2 \\
 f_{xyy} &= \frac{2}{(1+x-y)^3} & \Rightarrow f_{xyy}(0, 0) &= 2 \\
 f_{yyy} &= \frac{-2}{(1+x-y)^3} & \Rightarrow f_{yyy}(0, 0) &= -2
 \end{aligned}$$

and so on.

Substituting these in (1)

$$\begin{aligned}
 \log(1+x-y) &= 0 + (x-y) + \frac{1}{2!} \{-x^2 + 2xy - y^2\} \\
 &\quad + \frac{1}{3!} \{2x^3 - 6x^2y + 6xy^2 - 2y^3\} + \dots \\
 &= (x-y) - \frac{1}{2}(x-y)^2 + \frac{1}{3}(x-y)^3 + \dots
 \end{aligned}$$

9. Divide the number 48 into three parts such that its product is maximum.

**Solution.** Let  $x, y, z$  be the three parts of the number 48

$$\therefore x + y + z = 48$$

Also, let  $u = xyz$  and

$$F = xyz + \lambda(x + y + z)$$

We form the equations  $F_x = 0, F_y = 0, F_z = 0$

$$\text{i.e., } yz + \lambda = 0; \quad xz + \lambda = 0; \quad xy + \lambda = 0$$

$$\text{or } \lambda = -yz; \quad \lambda = -xz \quad \text{and} \quad \lambda = -xy$$

$$\Rightarrow -yz = -xz = -xy$$

and hence  $x = y = z$

Since  $x + y + z = 48$ , we get

$$x = y = z = 16$$

Thus, 16, 16, 16 are the three parts of 48 such that the product is maximum.

10. Find the minimum value of  $x^2 + y^2 + z^2$  when  $x + y + z = 3a$ .

**Solution.** Refer page no. 93. Example 4.

11. Find the stationary value of  $x^2 + y^2 + z^2$  subject to the condition  $xy + yz + zx = 3a^2$ .

**Solution.** Refer page no. 93. Example 5.

12. If  $x, y, z$  are the angles of a triangle, show that the maximum value of  $\cos x \cos y \cos z$  is  $\frac{1}{8}$ .

**Solution.** We need to find the maximum value of  $u = \cos x \cos y \cos z$  subject to the condition  $x + y + z = \pi$

$$\text{Let } F = \cos x \cos y \cos z + \lambda (x + y + z)$$

$$\text{We form the equations } F_x = 0, \quad F_y = 0, \quad F_z = 0$$

$$\text{i.e., } -\sin x \cos y \cos z + \lambda = 0$$

$$-\cos x \sin y \cos z + \lambda = 0$$

$$-\cos x \cos y \sin z + \lambda = 0$$

$$\text{or } \lambda = \sin x \cos y \cos z$$

$$\lambda = \cos x \sin y \cos z$$

$$\lambda = \cos x \cos y \sin z$$

$$\text{Now, } \sin x \cos y \cos z = \cos x \sin y \cos z = \cos x \cos y \sin z$$

From the first pair, we have

$$\sin x \cos y = \cos x \sin y$$

$$\text{i.e., } \sin x \cos y - \cos x \sin y = 0$$

$$\text{i.e., } \sin(x - y) = 0 \quad \Rightarrow \quad x - y = 0$$

$$\text{or } x = y$$

similarly from the other pairs, we get

$$y = z \text{ and } z = x$$

Combining these we have  $x = y = z$

$$\text{But } x + y + z = \lambda$$

$$\therefore x + x + x = \pi$$

$$\text{or } x = \frac{\pi}{3}$$

$$\text{Hence } x = y = z = \frac{\pi}{3}$$

$\therefore$  The maximum value of

$$\cos x \cos y \cos z = \cos^3 x, \text{ where } x = \frac{\pi}{3}$$

$$\text{Thus, we have } \cos^3\left(\frac{\pi}{3}\right) = \left(\frac{1}{2}\right)^3 = \frac{1}{8}.$$

13. Find the point on the paraboloid  $z = x^2 + y^2$  which is closest to the point  $(3, -6, 4)$ .

**Solution.** Let  $A(3, -6, 4)$  and let  $P(x, y, z)$  be any point on the paraboloid  $x^2 + y^2 - z = 0$

$$\therefore AP^2 = (x - 3)^2 + (y + 6)^2 + (z - 4)^2 \text{ by distance formula}$$

Let  $u(x, y, z) = (x - 3)^2 + (y + 6)^2 + (z - 4)^2$  and we need to find the point  $P_1 = (x_1, y_1, z_1)$

Satisfying  $z = x^2 + y^2$  such that  $AP_1^2$  is minimum.

Now, let  $F = [(x - 3)^2 + (y + 6)^2 + (z - 4)^2] + \lambda (x^2 + y^2 - z)$

We form the equation  $F_x = 0, F_y = 0, F_z = 0$

$$\text{i.e., } 2(x - 3) + 2\lambda x = 0 \quad \text{or} \quad \lambda = \frac{-(x-3)}{x} = -1 + \frac{3}{x}$$

$$2(y + 6) + 2\lambda y = 0 \quad \text{or} \quad \lambda = \frac{-(y+6)}{y} = -1 - \frac{6}{y}$$

$$2(z - 4) - \lambda = 0 \quad \text{or} \quad \lambda = 2z - 8$$

$$\therefore \quad -1 + \frac{3}{x} = -1 - \frac{6}{y} \Rightarrow \frac{3}{x} = \frac{-6}{y} \quad \text{or} \quad y = -2x$$

$$\text{Also} \quad -1 + \frac{3}{x} = 2z - 8 \Rightarrow 7 + \frac{3}{x} = 2z \quad \text{or} \quad z = \frac{1}{2} \left( 7 + \frac{3}{x} \right)$$

But we have  $x^2 + y^2 = z$

$$\therefore \quad x^2 + 4x^2 = \frac{7x+3}{2x} \quad \text{or} \quad 5x^2 = \frac{7x+3}{2x}$$

$$\text{or} \quad 10x^3 - 7x - 3 = 0$$

$x = 1$  is a root by inspection and is the only real root.

$$\text{Also} \quad y = -2x \quad \text{and} \quad z = \frac{1}{2} \left( 7 + \frac{3}{x} \right) \text{ gives}$$

$$y = -2, \quad z = 5$$

Thus the required point is  $(1, -2, 5)$ .

14. Find the dimensions of the rectangular box, open at the top, of the maximum capacity whose surface area is 432 sq. cm.

**Solution.** Let  $x, y, z$  respectively be the length, breadth and height of the rectangular box. Since it is open at the top, the surface area ( $S$ ) is given by

$$S = xy + 2xz + 2yz = 432 \text{ (using the data)}$$

$$\text{Volume} \quad (V) = xyz$$

We need to find  $x, y, z$  such that  $V$  is maximum subject to the condition that

$$xy + 2xz + 2yz = 432$$

$$\text{Let} \quad F = xyz + \lambda (xy + 2xz + 2yz)$$

We form the equation  $F_x = 0, F_y = 0, F_z = 0$

$$\text{i.e., } yz + \lambda (y + 2z) = 0 \quad \text{or} \quad \lambda = -yz/(y + 2z)$$

$$xz + \lambda (x + 2z) = 0 \quad \text{or} \quad \lambda = -xz/(x + 2z)$$

$$xy + \lambda (2x + 2y) = 0 \quad \text{or} \quad \lambda = -xy/2(x + y)$$

$$\text{Now} \quad \frac{-yz}{y + 2z} = \frac{-xz}{x + 2z} = \frac{-xy}{2(x + y)}$$

or  $\frac{y}{y+2z} = \frac{x}{x+2z}$  gives  $x = y$

Also  $\frac{z}{x+2z} = \frac{y}{2x+2y}$  gives  $y = 2z$

Hence,  $x = y = 2z$

But  $xy + 2xz + 2yz = 432$

$$x^2 + x^2 + x^2 = 432$$

or  $3x^2 = 432$  or  $x^2 = 144$

we have  $x = 12$  and hence  $y = 12, z = 6$

Thus the required dimensions are 12, 12, 6.

### OBJECTIVE QUESTIONS

- The necessary conditions for  $f(x, y) = 0$  to have extremum are
 

(a) $f_{xy} = 0, f_{yx} = 0$	(b) $f_{xx} = 0, f_{yy} = 0$
(c) $f_x = 0, f_y = 0$	(d) $f_x = 0, f_y = 0$ and $f_{xx} > 0, f_{yy} > 0$ .

[Ans. c]
- The stationary points of  $f(x, y) = x^2 + xy^2 + y^4$  is
 

(a) (1, 0)	(b) (0, 1)
(c) (0, 0)	(d) (1, 1).

[Ans. d]
- Minimum value of  $x^2 + y^2 + 6x + 14$  is
 

(a) 5	(b) 2
(c) 3	(d) -2.

[Ans. a]
- If  $p = q = 0, rt - s^2 > 0, r < 0$  then  $f(x, y)$  is
 

(a) Minimum	(b) Saddle point
(c) Maximum	(d) None of these.

[Ans. c]
- The conditions for  $f(x, y)$  to be minimum or maximum is  $p = \dots, q = \dots, rt - s^2 = \dots$  is
 

(a) 0, 0, +ve	(b) 1, -1, +ve
(c) 0, 0, -ve	(d) None of these.

[Ans. a]
- $\lim_{x \rightarrow -5} \frac{x^2 + 3x - 10}{x^3 + 125}$  is equal to
 

(a) $\frac{7}{25}$	(b) $\frac{7}{125}$
(c) $-\frac{7}{75}$	(d) None of these.

[Ans. c]

7.  $\lim_{x \rightarrow 3} \left[ \frac{x}{x-3} - \frac{9}{x^2-3x} \right]$  is equal to  
 (a) 0 (b) 3  
 (c) 9 (d) 2. [Ans. d]
8.  $\lim_{x \rightarrow 3} \left[ \frac{x}{x-3} - \frac{9}{x^2-3x} \right]$  is equal to  
 (a)  $\frac{1}{2}$  (b) 0  
 (c) 1 (d) None of these. [Ans. a]
9.  $\lim_{x \rightarrow 0} \frac{x}{\sqrt{1-\cos x}}$  is equal to  
 (a)  $\frac{1}{2}$  (b) 1  
 (c)  $\sqrt{2}$  (d) None of these. [Ans. c]
10.  $\lim_{x \rightarrow 0} \frac{x^2+x}{x+\sin x}$  is equal to  
 (a)  $\frac{1}{2}$  (b) 1  
 (c) 2 (d) None of these. [Ans. a]
11.  $\lim_{x \rightarrow \infty} \left( \frac{x}{x+1} \right)^x$  is equal to  
 (a) 2 (b)  $e$   
 (c) 1 (d) None of these. [Ans. c]
12.  $\lim_{x \rightarrow \frac{\pi}{4}} \frac{1-\tan x}{\frac{\pi}{4}-x}$  is equal to  
 (a) 2 (b) -2  
 (c) 1 (d) -1. [Ans. a]
13.  $\lim_{x \rightarrow 0} x \cot x$  is equal to  
 (a) 0 (b) 1  
 (c) doesn't exist (d) None of these. [Ans. b]

14.  $\lim_{x \rightarrow 0} \frac{\sec x - 1}{\tan^2 x}$  is equal to  
 (a) 2 (b) 1  
 (c) 0 (d)  $\frac{1}{2}$ . [Ans. d]
15.  $\lim_{x \rightarrow 0} \tan 5x \cot 3x$  is equal to  
 (a) 15 (b)  $\frac{1}{15}$   
 (c)  $\frac{5}{3}$  (d)  $\frac{3}{5}$ . [Ans. c]
16.  $\lim_{h \rightarrow 0} \frac{(x+h)^2 - x^2}{h}$  is equal to  
 (a) 1 (b)  $x$   
 (c) 0 (d)  $2x$ . [Ans. d]
17. The function  $(x)$  is continuous for  
 (a) all  $x$  (b)  $x \neq 0$   
 (c)  $x > 0$  (d)  $x < 0$ . [Ans. a]
18.  $\lim_{x \rightarrow \infty} \left(1 - \frac{1}{x}\right)^{-x}$  is equal to  
 (a)  $e^{-1}$  (b)  $e$   
 (c)  $e^{-x}$  (d)  $e^x$ . [Ans. b]
19. If  $rt - s^2 > 0$ ,  $r < 0$  then  $f(a, b)$  is  
 (a) Maximum value of  $f(x, y)$  (b) Minimum value of  $f(x, y)$   
 (c) Saddle point (d) None of these. [Ans. a]
20. If  $rt - s^2 > 0$ ,  $r > 0$  then  $f(a, b)$  is  
 (a) Maximum value of  $f(x, y)$  (b) Minimum value of  $f(x, y)$   
 (c) Saddle point (d) None of these. [Ans. b]
21. If  $rt - s^2 < 0$  then  $(a, b)$  is  
 (a) Maximum value of  $f(x, y)$  (b) Minimum value of  $f(x, y)$   
 (c) Saddle point  $f(x, y)$  (d) None of these. [Ans. c]
22. If  $L(x, y, z, \lambda) = f(x, y, z) + \lambda \phi(x, y, z)$  is called  
 (a) Particular function (b) Auxillary function  
 (c) General function (d) None of these. [Ans. b]



23. To find maxima or minima of  $f(x, y, z)$  subject to

(a)  $\phi(x, y, z) = 0$

(b)  $f(x, y, z) = 0$

(c)  $\phi(x, y, z) \neq 0$

(d)  $f(x, y, z) \neq 0$ .

[Ans. a]

24. A set of necessary conditions for  $f(x, y)$  to have a maximum or minimum is that

(a)  $\frac{\partial f}{\partial x} = 0$  and  $\frac{\partial f}{\partial y} \neq 0$

(b)  $\frac{\partial f}{\partial x} \neq 0$  and  $\frac{\partial f}{\partial y} = 0$

(c)  $\frac{\partial f}{\partial x} = 0$  and  $\frac{\partial f}{\partial y} = 0$

(d) None of these.

[Ans. c]

25. The stationary points of  $f(x, y) = y^2 + 4xy + 3x^2 + x^3$  is

(a)  $(0, 1)$  and  $\left(\frac{2}{3}, 1\right)$

(b)  $(0, 0)$  and  $\left(\frac{2}{3}, \frac{-4}{3}\right)$

(c)  $(0, 2)$  and  $\left(\frac{2}{3}, \frac{4}{3}\right)$

(d) None of these.

[Ans. b]

□□□

## ***Integral Calculus***

---

### **3.1 INTRODUCTION**

In this section we study the double and triple integrals (multiple integrals) are defined in the same way as the definite integral of a function of a single variable along with the applications. We also discuss two special functions, ‘Beta function’ and ‘Gamma function’ defined in the form of definite integrals.

### **3.2 MULTIPLE INTEGRALS**

In this topic we discuss a repeated process of integration of a function of two and three variables referred to as

double integrals:  $\iint f(x, y) dx dy$  and

triple integrals:  $\iiint f(x, y, z) dx dy dz$ .

### **3.3 DOUBLE INTEGRALS**

The double integral of a function  $f(x, y)$  over a region  $D$  in  $R^2$  is denoted by  $\iint_D f(x, y) dx dy$

Let  $f(x, y)$  be a continuous function in  $R^2$  defined on a closed rectangle

$$R = \{(x, y) / a \leq x \leq b \text{ and } c \leq y \leq d\}$$

For any fixed  $x \in [a, b]$  consider the integral  $\int_c^d f(x, y) dy$ .

The value of this integral depends on  $x$  and we get a new function of  $x$ . This can be integrated depends on  $x$  and, we get  $\int_a^b \left[ \int_c^d f(x, y) dy \right] dx$ . This is called an “**iterated integral**”.

Similarly, we can define another

$$\int_c^d \left[ \int_a^b f(x, y) dx \right] dy$$

For continuous function  $f(x, y)$ , we have

$$\iint_R f(x, y) dx dy = \int_a^b \left[ \int_c^d f(x, y) dy \right] dx = \int_c^d \left[ \int_a^b f(x, y) dx \right] dy$$

If  $f(x, y)$  is continuous on a bounded region  $S$  and  $S$  is given by

$S = \{(x, y) / a \leq x \leq b \text{ and } \phi_1(x) \leq y \leq \phi_2(x)\}$ , where  $\phi_1$  and  $\phi_2$  are two continuous functions on  $[a, b]$  then

$$\iint_S f(x, y) dx dy = \int_a^b \left[ \int_{\phi_1(x)}^{\phi_2(x)} f(x, y) dy \right] dx$$

The iterated integral in the R.H.S. is also written in the form

$$\int_a^b dx \int_{\phi_1(x)}^{\phi_2(x)} f(x, y) dy$$

Similarly, if

$$S = \{(x, y) / c \leq y \leq d \text{ and } \phi_1(y) \leq x \leq \phi_2(y)\}$$

then 
$$\iint_S f(x, y) dx dy = \int_c^d \left[ \int_{\phi_1(y)}^{\phi_2(y)} f(x, y) dx \right] dy$$

If  $S$  cannot be written in neither of the above two forms we divide  $S$  into finite number of subregions such that each of the subregions can be represented in one of the above forms and we get the double integral over  $S$  by adding the integrals over these subregions.

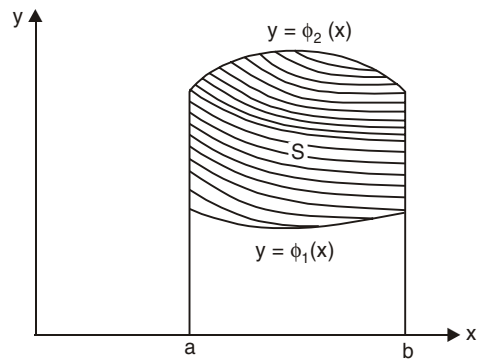

Fig. 3.1

## WORKED OUT EXAMPLES

1. Evaluate:  $I = \int_0^1 \int_0^2 xy^2 dy dx$ .

**Solution**

$$\begin{aligned} I &= \int_0^1 \left[ \int_0^2 xy^2 dy \right] dx \\ &= \int_0^1 \left[ \frac{xy^3}{3} \right]_0^2 dx && \text{(Integrating w.r.t. } y \text{ keeping } x \text{ constant)} \\ &= \frac{1}{3} \int_0^1 8x dx \\ &= \frac{1}{3} \left[ \frac{8x^2}{2} \right]_0^1 = \frac{4}{3}. \end{aligned}$$

2. Evaluate:  $\int_0^1 \int_1^2 xy \, dy \, dx$ .

**Solution.** Let  $I$  be the given integral

$$\begin{aligned} \text{Then,} \quad I &= \int_0^1 x \left\{ \int_1^2 y \, dy \right\} dx \\ &= \int_0^1 x \cdot \left[ \frac{y^2}{2} \right]_1^2 dx = \frac{3}{2} \int_0^1 x \, dx = \frac{3}{4}. \end{aligned}$$

3. Evaluate the following:

(i)  $\int_1^2 \int_2^3 e^{x+y} \, dy \, dx$

(ii)  $\int_0^1 \int_{x^2}^x dy \, dx$

(iii)  $\int_1^2 \int_y^{3y} (x+y) \, dx \, dy$

(iv)  $\int_0^\pi \int_0^{\cos \theta} r \sin \theta \, dr \, d\theta$

**Solution.** Let  $I$  be the given integral. Then

$$\begin{aligned} \text{(i)} \quad I &= \int_1^2 e^x \left( \int_2^3 e^y \, dy \right) dx \\ &= \int_1^2 e^x [e^y]_2^3 dx \\ &= \int_1^2 e^x (e^3 - e^2) dx \\ &= (e^3 - e^2) \int_1^2 e^x dx \\ &= (e^3 - e^2) [e^x]_1^2 \\ I &= (e^3 - e^2)(e^2 - e^1). \end{aligned}$$

$$\begin{aligned} \text{(ii)} \quad I &= \int_0^1 \left\{ \int_{x^2}^x dy \right\} dx \\ &= \int_0^1 [y]_{x^2}^x dx = \int_0^1 (x - x^2) dx \\ &= \left[ \frac{x^2}{2} - \frac{x^3}{3} \right]_0^1 \\ &= \frac{1}{2} - \frac{1}{3} = \frac{1}{6} \end{aligned}$$

$$\begin{aligned} \text{(iii)} \quad I &= \int_1^2 \left\{ \int_y^{3y} (x+y) \, dx \right\} dy \\ &= \int_1^2 \left[ \frac{x^2}{2} + xy \right]_{x=y}^{x=3y} dy \\ &= \int_1^2 6y^2 \, dy = [2y^3]_1^2 = 14 \end{aligned}$$

$$\begin{aligned}
 (iv) \quad I &= \int_0^\pi \sin \theta \left\{ \int_0^{\cos \theta} r \, dr \right\} d\theta \\
 &= \int_0^\pi \sin \theta \left[ \frac{r^2}{2} \right]_0^{\cos \theta} d\theta \\
 &= \frac{1}{2} \int_0^\pi \sin \theta \cdot \cos^2 \theta \, d\theta
 \end{aligned}$$

where

$$\begin{aligned}
 \cos \theta &= t \\
 -\sin \theta \, d\theta &= dt \\
 \therefore \sin \theta \, d\theta &= -dt \\
 &= \frac{1}{2} \int_0^\pi t^2 \cdot (-dt) \\
 &= \frac{-1}{2} \left[ \frac{t^3}{3} \right]_0^\pi \\
 &= \frac{-1}{6} [\cos \theta]_0^\pi \\
 &= \frac{-1}{6} (-1 - 1) = \frac{1}{3}.
 \end{aligned}$$

4. Evaluate:  $\int_0^1 \int_0^{\sqrt{1+x^2}} \frac{dy \, dx}{1+x^2+y^2}$ .

**Solution**

$$I = \int_0^1 \left\{ \int_0^{\sqrt{1+x^2}} \frac{dy}{1+x^2+y^2} \right\} dx$$

where

$$\begin{aligned}
 a^2 &= 1+x^2 \text{ or } a = \sqrt{1+x^2} \\
 &= \int_0^1 \left\{ \int_0^a \frac{dy}{a^2+y^2} \right\} dx \\
 &= \int_0^1 \left[ \frac{1}{a} \tan^{-1} \frac{y}{a} \right]_0^a dx \\
 &= \int_0^1 \frac{1}{a} \cdot \frac{\pi}{4} dx = \frac{\pi}{4} \int_0^1 \frac{dx}{\sqrt{x^2+1}} \\
 &= \frac{\pi}{4} \left[ \log \left\{ x + \sqrt{x^2+1} \right\} \right]_0^1 \\
 &= \frac{\pi}{4} \log(\sqrt{2}+1)
 \end{aligned}$$

**Note :**  $\frac{\pi}{4} \left[ \log \left\{ x + \sqrt{x^2+1} \right\} \right]_0^1 = \frac{\pi}{4} \left[ \sin^{-1} x \right]_0^1 = \frac{\pi}{4} \sin^{-1}(1)$

5. Evaluate:  $\int_{-c}^c \int_{-b}^b \int_{-a}^a (x^2 + y^2 + z^2) dz dy dx$ .

**Solution** 
$$I = \int_{x=-c}^c \int_{y=-b}^b \int_{z=-a}^a (x^2 + y^2 + z^2) dz dy dx$$

Integrating w.r.t.  $z$ ,  $x$  and  $y$  – constant.

$$\begin{aligned} &= \int_{x=-c}^c \int_{y=-b}^b \left[ x^2 z + y^2 z + \frac{z^3}{3} \right]_{z=-a}^a dy dx \\ &= \int_{x=-c}^c \int_{y=-b}^b \left[ x^2(a+a) + y^2(a+a) + \left( \frac{a^3}{3} + \frac{a^3}{3} \right) \right] dy dx \\ &= \int_{x=-c}^c \int_{y=-b}^b \left( 2ax^2 + 2ay^2 + \frac{2a^3}{3} \right) dy dx \end{aligned}$$

Integrating w.r.t.  $y$ ,  $x$  – constant.

$$\begin{aligned} &= \int_{x=-c}^c \left[ 2ax^2 y + \frac{2ay^3}{3} + \frac{2a^3}{3} y \right]_{y=-b}^b dx \\ &= \int_{x=-c}^c \left[ 2ax^2(b+b) + \frac{2a}{3}(b^3+b^3) + \frac{2a^3}{3}(b+b) \right] dx \\ &= \int_{x=-c}^c \left[ 4ax^2 b + \frac{4ab^3}{3} + \frac{4a^3 b}{3} \right] dx \\ &= \left[ 4ab \left( \frac{x^3}{3} \right) + \frac{4ab^3}{3}(x) + \frac{4a^3 b}{3}(x) \right]_{-c}^c \\ &= 4ab \left( \frac{2c^3}{3} \right) + \frac{4ab^3}{3} \cdot (2c) + \frac{4a^3 b}{3} (2c) \\ &= \frac{8abc^3}{3} + \frac{8ab^3 c}{3} + \frac{8a^3 bc}{3} \\ I &= \frac{8abc}{3} (a^2 + b^2 + c^2). \end{aligned}$$

6. Evaluate:  $\int_0^a \int_0^x \int_0^{x+y} e^{x+y+z} dz dy dx$ .

**Solution** 
$$I = \int_{x=0}^a \int_{y=0}^x \int_{z=0}^{x+y} e^{x+y} \cdot e^z dz dy dx$$

$$\begin{aligned}
&= \int_{x=0}^a \int_{y=0}^x e^{x+y} \cdot [e^z]_0^{x+y} dy dx \\
&= \int_{x=0}^a \int_{y=0}^x e^{x+y} (e^{x+y} - 1) dy dx \\
&= \int_{x=0}^a \int_{y=0}^x (e^{2x} \cdot e^{2y} - e^x \cdot e^y) dy dx \\
&= \int_{x=0}^a \left\{ e^{2x} \left[ \frac{e^{2y}}{2} \right]_0^x - e^x [e^y]_0^x \right\} dx \\
&= \int_{x=0}^a \left\{ \frac{e^{2x}}{2} (e^{2x} - 1) - e^x (e^x - 1) \right\} dx \\
&= \int_{x=0}^a \left( \frac{e^{4x}}{2} - \frac{3}{2} e^{2x} + e^x \right) dx \\
&= \left[ \frac{e^{4x}}{8} - \frac{3e^{2x}}{4} + e^x \right]_0^a \\
&= \left( \frac{e^{4a}}{8} - \frac{3e^{2a}}{4} + e^a \right) - \left( \frac{1}{8} - \frac{3}{4} + 1 \right) \\
&= \frac{e^{4a}}{8} - \frac{3e^{2a}}{4} + e^a - \frac{3}{8} \\
I &= \frac{1}{8} (e^{4a} - 6e^{2a} + 8e^a - 3).
\end{aligned}$$

7. Evaluate:  $\int_0^{\log 2} \int_0^x \int_0^{x+\log y} e^{x+y+z} dz dy dx$ .

**Solution**

$$\begin{aligned}
I &= \int_{x=0}^{\log 2} \int_{y=0}^x \int_{z=0}^{x+\log y} e^{x+y} \cdot e^z dz dy dx \\
&= \int_{x=0}^{\log 2} \int_{y=0}^x e^{x+y} [e^z]_0^{x+\log y} dy dx \\
&= \int_{x=0}^{\log 2} \int_{y=0}^x e^{x+y} [e^{x+\log y} - 1] dy dx \\
&= \int_{x=0}^{\log 2} \int_{y=0}^x e^{x+y} [e^x \cdot e^{\log y} - 1] dy dx
\end{aligned}$$

But  $e^{\log y} = y$

$\therefore$

$$I = \int_{x=0}^{\log 2} \int_{y=0}^x (e^{2x} \cdot y \cdot e^y - e^x e^y) dy dx$$

$$\begin{aligned}
 &= \int_{x=0}^{\log 2} \left[ e^{2x} (y e^y - e^y) - e^x e^y \right]_{y=0}^x dx \\
 &= \int_{x=0}^{\log 2} \left[ e^{2x} \{ (x e^x - e^x) - (0-1) \} - e^x (e^x - 1) \right] dx \\
 &= \int_{x=0}^{\log 2} (x e^{3x} - e^{3x} + e^{2x} - e^{2x} + e^x) dx \\
 &= \int_{x=0}^{\log 2} (x e^{3x} - e^{3x} + e^x) dx \\
 &= \left[ x \cdot \frac{e^{3x}}{3} - \frac{e^{3x}}{9} - \frac{e^{3x}}{3} + e^x \right]_0^{\log 2} \\
 &= \left[ \frac{x e^{3x}}{3} - \frac{4 e^{3x}}{9} + e^x \right]_0^{\log 2} \\
 &= \left[ \frac{\log 2 \cdot e^{3 \log 2}}{3} - 0 \right] - \frac{4}{9} (e^{3 \log 2} - 1) + (e^{\log 2} - 1) \\
 &= \frac{8 \log 2}{3} - \frac{4}{9} (8-1) + (2-1) \\
 &= \frac{8 \log 2}{3} - \frac{28}{9} + 1
 \end{aligned}$$

Thus,

$$I = \frac{8 \log 2}{3} - \frac{19}{9}.$$

8. Evaluate:  $\int_0^a \int_0^{\sqrt{a^2 - y^2}} \sqrt{a^2 - x^2 - y^2} dx dy.$

**Solution**

$$\begin{aligned}
 I &= \int_0^a \left\{ \int_0^{\sqrt{a^2 - y^2}} \sqrt{(a^2 - y^2) - x^2} dx \right\} dy \\
 &= \int_0^a \left\{ \int_0^b \sqrt{b^2 - x^2} \right\} dy
 \end{aligned}$$

where

$$\begin{aligned}
 b^2 &= a^2 - y^2 \\
 &= \int_0^a \left[ \frac{x}{2} \sqrt{b^2 - x^2} + \frac{b^2}{2} \sin^{-1} \frac{x}{b} \right]_0^b dy \\
 &= \int_0^a \frac{b^2}{2} \cdot \frac{\pi}{2} dy = \frac{\pi}{4} \int_0^a (a^2 - y^2) dy \\
 &= \frac{\pi}{4} \left[ a^2 y - \frac{y^3}{3} \right]_0^a = \frac{\pi a^3}{6}
 \end{aligned}$$



### EXERCISE 3.1

#### I. Evaluate the following double integrals:

1.  $\int_0^3 \int_1^2 xy(x+y) dy dx$  [Ans. 24]
2.  $\int_0^{\pi/2} \int_0^{\pi/2} \sin(x+y) dy dx$  [Ans. 2]
3.  $\int_0^1 \int_0^{x^2} ce^y dy dx$  [Ans.  $\frac{1}{2}e - 1$ ]
4.  $\int_0^1 \int_0^{1-x} xy dy dx$  [Ans.  $\frac{1}{24}$ ]
5.  $\int_0^1 \int_0^{1-x} (x+y)^2 dy dx$  [Ans.  $\frac{1}{4}$ ]
6.  $\int_0^1 \int_0^{y^2} e^{x/y} dx dy$  [Ans.  $\frac{1}{2}$ ]
7.  $\int_0^a \int_0^{\sqrt{a^2-x^2}} x^2 y dy dx$  [Ans.  $\frac{a^5}{15}$ ]
8.  $\int_0^\infty \int_y^\infty x e^{-x^2/y} dx dy$  [Ans.  $\frac{1}{2}$ ]
9.  $\int_0^{4a} \int_{y^2/4a}^{2\sqrt{ay}} dx dy$  [Ans.  $\frac{16}{3}a^2$ ]
10.  $\int_{\theta=0}^{\pi/2} \int_{r=0}^{a \cos \theta} \frac{a r}{\sqrt{a^2 - r^2}} dr d\theta$  [Ans.  $a^2 \left( \frac{\pi}{2} - 1 \right)$ ]

#### II. Evaluate the triple integrals:

1.  $\int_0^2 \int_1^3 \int_1^2 xy^2 z dz dy dx$  [Ans. 26]
2.  $\int_{-3}^3 \int_0^1 \int_1^2 (x+y+z) dx dy dz$  [Ans. 12]
3.  $\int_0^1 \int_0^1 \int_0^y xyz dx dy dz$  [Ans.  $\frac{1}{16}$ ]
4.  $\int_0^1 \int_{y^2}^1 \int_0^{1-x} x dz dx dy$  [Ans.  $\frac{4}{35}$ ]
5.  $\int_0^1 \int_0^1 \int_{\sqrt{x^2+y^2}}^2 xyz dz dy dx$  [Ans.  $\frac{3}{8}$ ]
6.  $\int_0^4 \int_0^{2\sqrt{z}} \int_0^{\sqrt{4z-x^2}} dy dx dz$  [Ans.  $8\pi$ ]
7.  $\int_{-1}^1 \int_0^z \int_{x-z}^{x+z} (x+y+z) dy dx dz$  [Ans. 0]
8.  $\int_0^{\pi/2} \int_0^{a \sin \theta} \int_0^{(a^2-r^2)/a} r dr d\theta$  [Ans.  $\frac{5\pi a^3}{64}$ ]
9.  $\int_0^1 \int_0^{1-x} \int_0^{1-x-y} \frac{dz dy dx}{(1+x+y+z)^3}$  [Ans.  $\frac{1}{2} \left( \log 2 - \frac{5}{8} \right)$ ]
10.  $\int_0^a \int_0^{\sqrt{a^2-x^2}} \int_0^{\sqrt{a^2-x^2-y^2}} xyz dz dy dx$  [Ans.  $\frac{a^6}{48}$ ]

### 3.3.1 Evaluation of a Double Integral by Changing the Order of Integration

In the evaluation of the double integrals sometimes we may have to change the order of integration so that evaluation is more convenient. If the limits of integration are variables then change in the order of integration changes the limits of integration. In such cases a rough idea of the region of integration is necessary.

### 3.3.2 Evaluation of a Double Integral by Change of Variables

Sometimes the double integral can be evaluated easily by changing the variables.

Suppose  $x$  and  $y$  are functions of two variables  $u$  and  $v$ .

*i.e.*,  $x = x(u, v)$  and  $y = y(u, v)$  and the Jacobian

$$J = \frac{\partial(x, y)}{\partial(u, v)} = \begin{vmatrix} \frac{\partial x}{\partial u} & \frac{\partial x}{\partial v} \\ \frac{\partial y}{\partial u} & \frac{\partial y}{\partial v} \end{vmatrix} \neq 0$$

Then the region  $A$  changes into the region  $R$  under the transformations

$$x = x(u, v) \text{ and } y = y(u, v)$$

$$\text{Then} \quad \iint_A f(x, y) dx dy = \iint_R f(u, v) J du dv$$

$$\text{If} \quad x = r \cos \theta, y = r \sin \theta$$

$$J = \frac{\partial(x, y)}{\partial(r, \theta)} = \begin{vmatrix} \frac{\partial x}{\partial r} & \frac{\partial x}{\partial \theta} \\ \frac{\partial y}{\partial r} & \frac{\partial y}{\partial \theta} \end{vmatrix} = \begin{vmatrix} \cos \theta & -r \sin \theta \\ \sin \theta & r \cos \theta \end{vmatrix} = r$$

$$\therefore \iint_A f(x, y) dx dy = \iint_R F(r, \theta) r dr d\theta. \quad \dots(1)$$

### 3.3.3 Applications to Area and Volume

1.  $\iint_R dx dy = \text{Area of the region } R \text{ in the Cartesian form.}$

2.  $\iint_R r \cdot dr d\theta = \text{Area of the region } R \text{ in the polar form.}$

3.  $\iiint_V dx dy dz = \text{Volume of a solid.}$

4. Volume of a solid (in polars) obtained by the revolution of a curve enclosing an area  $A$  about the initial line is given by

$$V = \iint_A 2\pi r^2 \sin \theta \cdot dr d\theta.$$

5. If  $z = f(x, y)$  be the equation of a surface  $S$  then the surface area is given by

$$\iint_A \sqrt{1 + \left(\frac{\partial z}{\partial x}\right)^2 + \left(\frac{\partial z}{\partial y}\right)^2} dx dy$$

Where  $A$  is the region representing the projection of  $S$  on the  $xy$ -plane.

### WORKED OUT EXAMPLES

#### Type 1. Evaluation over a given region

1. Evaluate  $\iint_R xy dx dy$  where  $R$  is the triangular region bounded by the axes of coordinates and the line  $\frac{x}{a} + \frac{y}{b} = 1$ .

**Solution.**  $R$  is the region bounded by  $x = 0$ ,  $y = 0$  being the coordinates axes and  $\frac{x}{a} + \frac{y}{b} = 1$  being the straight line through  $(0, a)$  and  $\left(0, b\left(1 - \frac{x}{a}\right)\right)$

when  $x$  is held fixed and  $y$  varies from 0 to  $b\left(1 - \frac{x}{a}\right)$

$$\therefore \frac{x}{a} + \frac{y}{b} = 1$$

$$\Rightarrow \frac{y}{b} = 1 - \frac{x}{a}$$

$$\Rightarrow y = b\left(1 - \frac{x}{a}\right)$$

$$\begin{aligned} \therefore \iint_R xy dx dy &= \int_{x=0}^a \left\{ \int_{y=0}^{b\left(1-\frac{x}{a}\right)} xy dy \right\} dx \\ &= \int_0^a x \cdot \left[ \frac{y^2}{2} \right]_0^{b\left(1-\frac{x}{a}\right)} dx \\ &= \int_0^a \left\{ x \cdot \frac{b^2}{2} \left(1 - \frac{x}{a}\right)^2 \right\} dx \\ &= \frac{b^2}{2} \int_0^a \left( x - 2\frac{x^2}{a} + \frac{x^3}{a^2} \right) dx \\ &= \frac{b^2}{2} \left[ \frac{x^2}{2} - \frac{2x^3}{3a} + \frac{x^4}{4a^2} \right]_0^a \end{aligned}$$

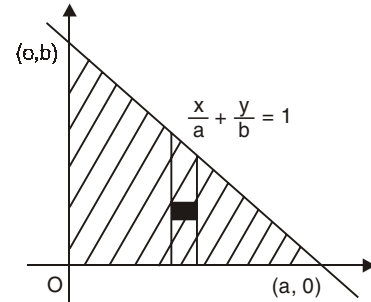

Fig. 3.2

$$= \frac{b^2}{2} \left[ \frac{a^2}{2} - \frac{2}{3} a^2 + \frac{1}{4} a^2 \right]$$

$$= \frac{a^2 b^2}{24}$$

2. Evaluate  $\iint xy \, dx \, dy$  over the area in the first quadrant bounded by the circle  $x^2 + y^2 = a^2$ .

**Solution** 
$$\iint xy \, dx \, dy = \int_{x=0}^a \left[ \int_{y=0}^{\sqrt{a^2-x^2}} xy \, dy \right] dx$$

$$\begin{cases} \because x^2 + y^2 = a^2 \\ \Rightarrow y^2 = a^2 - x^2 \\ y = \sqrt{a^2 - x^2} \end{cases}$$

$$= \int_0^a x \cdot \left[ \frac{y^2}{2} \right]_0^{\sqrt{a^2-x^2}} dx$$

$$= \int_0^a x \left( \frac{a^2 - x^2}{2} \right) dx$$

$$= \frac{1}{2} \int_0^a (a^2 x - x^3) dx$$

$$= \frac{1}{2} \left[ a^2 \frac{x^2}{2} - \frac{x^4}{4} \right]_0^a$$

$$= \frac{1}{2} \left[ \frac{a^4}{2} - \frac{a^4}{4} \right] = \frac{a^4}{8}$$

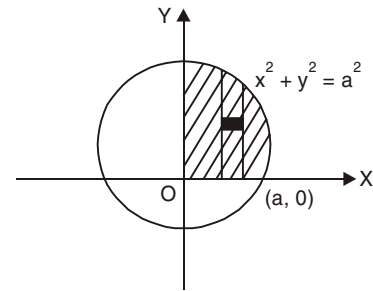

Fig. 3.3

3. Evaluate  $\iint_R x \, dx \, dy$  where  $R$  is the region bounded by  $\frac{x^2}{a^2} + \frac{y^2}{b^2} = 1$  and lying in the first quadrant.

**Solution.** From the ellipse

$$\frac{x^2}{a^2} + \frac{y^2}{b^2} = 1$$

$$\frac{y^2}{b^2} = 1 - \frac{x^2}{a^2}$$

$$y = \frac{b}{a} \sqrt{a^2 - x^2}$$

$x$  changes from 0 to  $a$  and  $y$  changes from 0 to  $\frac{b}{a} \sqrt{a^2 - x^2}$

$$\iint_R x \, dx \, dy = \int_{x=0}^a \left\{ \int_{y=0}^{\frac{b}{a} \sqrt{a^2-x^2}} x \, dy \right\} dx$$

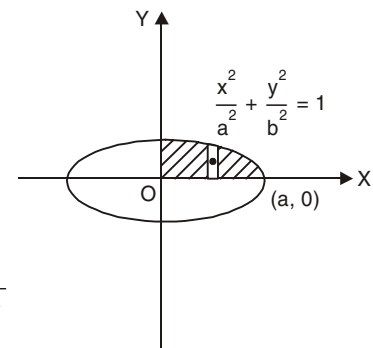

Fig. 3.4

$$\begin{aligned}
 &= \int_0^a x \left[ y \right]_0^{\frac{b}{a} \sqrt{a^2 - x^2}} dx \\
 &= \int_0^a \left( x \frac{b}{a} \sqrt{a^2 - x^2} \right) dx
 \end{aligned}$$

Putting  $x = a \sin \theta$ ,  $dx = a \cos \theta d\theta$

$$\sqrt{a^2 - x^2} = a \cos \theta$$

$\therefore \theta$  varies from 0 to  $\pi/2$

$$\begin{aligned}
 &= \frac{b}{a} \int_0^{\pi/2} a \sin \theta \cdot a \cos \theta \cdot a \cos \theta d\theta \\
 &= a^2 b \int_0^{\pi/2} \sin \theta \cos^2 \theta d\theta \\
 &= a^2 b \times \frac{1}{3} = \frac{a^2 b}{3}.
 \end{aligned}$$

4. Evaluate  $\iint_R xy \, dx \, dy$  where  $R$  is the region in the first quadrant included between

$$\frac{x^2}{a^2} + \frac{y^2}{b^2} = 1 \text{ and } \frac{x}{a} + \frac{y}{b} = 1.$$

**Solution**

$$\frac{x}{a} + \frac{y}{b} = 1$$

$$\begin{aligned}
 \Rightarrow y &= b \left( 1 - \frac{x}{a} \right) \\
 &= \frac{b}{a} (a - x)
 \end{aligned}$$

$$\frac{x^2}{a^2} + \frac{y^2}{b^2} = 1$$

$$\Rightarrow \frac{y^2}{b^2} = 1 - \frac{x^2}{a^2}$$

$$y = \frac{b}{a} \sqrt{a^2 - x^2}$$

$$\therefore \iint_R xy \, dx \, dy = \int_0^a \left\{ \int_{y=\frac{b}{a}(a-x)}^{\frac{b}{a} \sqrt{a^2 - x^2}} xy \, dy \right\} dx$$

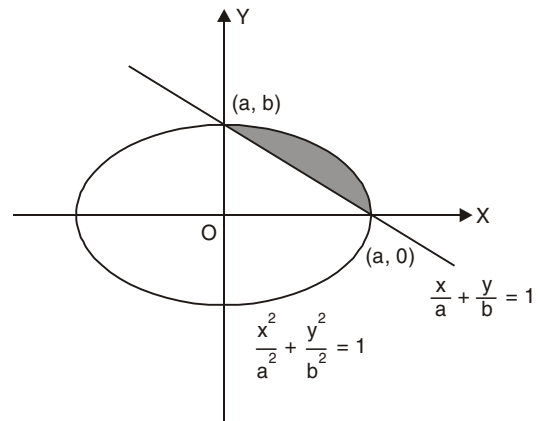

**Fig. 3.5**

( $\because y \geq 0$ )

$$\begin{aligned}
 &= \int_0^a x \left[ \frac{y^2}{2} \right]_{\frac{b}{a}(a-x)}^{\frac{b}{a}\sqrt{a^2-x^2}} dx \\
 &= \frac{1}{2} \int_0^a x \left[ \frac{b^2}{a^2} (a^2 - x^2) - \frac{b^2}{a^2} (a-x)^2 \right] dx \\
 &= \frac{b^2}{2a^2} \int_0^a (2ax^2 - 2x^3) dx \\
 &= \frac{b^2}{2a^2} \left[ 2a \frac{x^3}{3} - \frac{x^4}{2} \right]_0^a \\
 &= \frac{b^2}{2a^2} \left[ \frac{2a^4}{3} - \frac{a^4}{2} \right] = \frac{a^2 b^2}{12}.
 \end{aligned}$$

5. Evaluate  $\iint_R xy^2 dx dy$  where  $R$  is the Triangular region bounded by  $y = 0$ ,  $x = y$  and  $x + y = 2$ .

**Solution.** Given

$$y = 0, x = y, x + y = 2$$

where  $y = 0, y + y = 2$

$$\Rightarrow 2y = 2$$

$$\Rightarrow y = 1$$

where  $x = y, x = 2 - y$

$\therefore y$  varies from 0 to 1

$x$  varies from  $y$  to  $2 - y$

$$\begin{aligned}
 \iint_R xy^2 dx dy &= \int_{y=0}^1 \int_{x=y}^{2-y} xy^2 dx dy \\
 &= \int_{y=0}^1 y^2 \left[ \frac{x^2}{2} \right]_{x=y}^{2-y} dy \\
 &= \frac{1}{2} \int_0^1 y^2 \{ (2-y)^2 - y^2 \} dy \\
 &= \frac{1}{2} \int_0^1 y^2 (4 - 4y) dy \\
 &= \frac{1}{2} \left[ \frac{4}{3} y^3 - y^4 \right]_0^1 = \frac{1}{6}.
 \end{aligned}$$

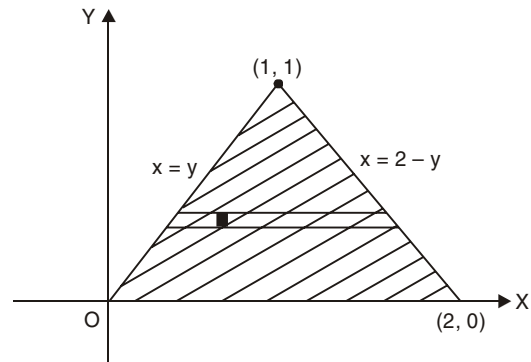

Fig. 3.6

6. Evaluate  $\iint_R xy(x+y) dx dy$  over the region between  $y = x^2$  and  $y = x$ .

**Solution.** The bounded curves are  $y = x^2$  and  $y = x$ . The common points are given by solving the two equations.

So, we have

$$x^2 = x \Rightarrow x(x-1) = 0$$

$$\Rightarrow x = 0 \text{ or } 1$$

when  $x = 0$ , we have  $y = 0$  and

when  $x = 1$ ,  $y = 1$  (from  $y = x$ )

$$\begin{aligned} \therefore \iint_R xy(x+y) dx dy &= \int_{x=0}^1 \int_{y=x^2}^x xy(x+y) dy dx \\ &= \int_0^1 x \left[ \frac{xy^2}{2} + \frac{y^3}{3} \right]_{x^2}^x dx \\ &= \int_0^1 x \left\{ x \left( \frac{x^2}{2} - \frac{x^4}{2} \right) + \left( \frac{x^3}{3} - \frac{x^6}{3} \right) \right\} dx \\ &= \int_0^1 \left( \frac{5}{6} x^4 - \frac{x^6}{2} - \frac{x^7}{3} \right) dx \\ &= \left[ \frac{5}{6} \frac{x^5}{5} - \frac{x^7}{14} - \frac{x^8}{24} \right]_0^1 \\ &= \frac{1}{6} - \frac{1}{14} - \frac{1}{24} = \frac{3}{56}. \end{aligned}$$

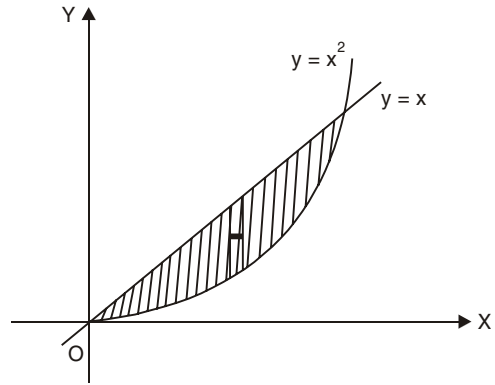

Fig. 3.7

7. Evaluate  $\iint_R xy dx dy$  where  $R$  is the region bounded by the  $x$ -axis, ordinate at  $x = 2a$  and  $x^2 = 4ay$ .

**Solution**

When  $x = 2a$  and  $x^2 = 4ay$

$$\therefore 4a^2 = 4ay$$

$$\Rightarrow y = a$$

$\therefore$  The point of intersection of

$$x = 2a \text{ and } x^2 = 4ay \text{ is } (2a, a)$$

$$\text{Now } \iint_R xy dx dy = \int_{x=0}^{2a} \int_{y=0}^{\frac{x^2}{4a}} xy dy dx$$

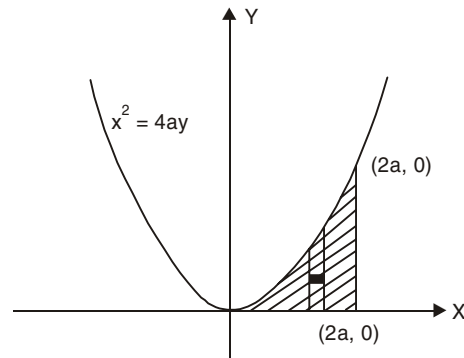

Fig. 3.8

$$\begin{aligned}
 &= \int_0^{2a} x \left[ \frac{y^2}{2} \right]_0^{\frac{x^2}{2}} dx \\
 &= \int_0^{2a} \frac{x^5}{32a^2} dx = \left[ \frac{x^6}{32a^2 \times 6} \right]_0^{2a} = \frac{a^4}{3}
 \end{aligned}$$

**Type 2. Evaluation of a double integral by changing the order of integration**

1. Change the order of integration and hence evaluate  $\int_0^a \int_0^{2\sqrt{ax}} x^2 dy dx$ .

**Solution**  $y = 2\sqrt{ax}$   
 $\Rightarrow y^2 = 4ax$   
 when  $x = a$  on  $y^2 = 4ax$ ,  $y^2 = 4a^2$   
 $\Rightarrow y = \pm 2a$   
 So, on  $y = 2\sqrt{ax}$ ,  $y = 2a$  when  $x = a$   
 The integral is over the shaded region.

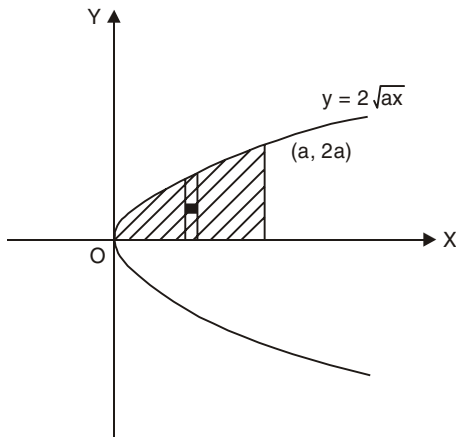

Fig. 3.9

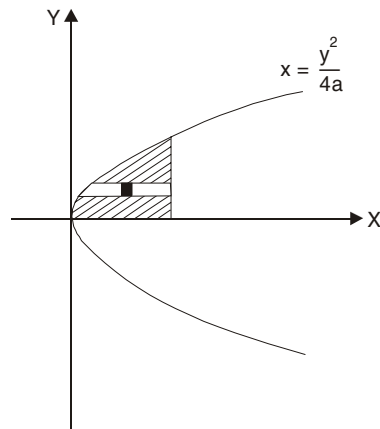

Fig. 3.10

$$\begin{aligned}
 \int_0^a \int_0^{2\sqrt{ax}} x^2 dy dx &= \int_{y=0}^{2a} \int_{x=\frac{y^2}{4a}}^a x^2 dx dy \\
 &= \int_0^{2a} \left[ \frac{x^3}{3} \right]_{\frac{y^2}{4a}}^a dy
 \end{aligned}$$

(By changing the order)



$$\begin{aligned}
 &= \int_0^{2a} \left( \frac{a^3}{3} - \frac{y^6}{192a^3} \right) dy \\
 &= \left[ \frac{a^3}{3} y - \frac{y^7}{192a^3 \times 7} \right]_0^{2a} \\
 &= \frac{2a^4}{3} - \frac{2^7 a^4}{192 \times 7} \\
 &= a^4 \left( \frac{2}{3} - \frac{2}{21} \right) = \frac{4}{7} a^4.
 \end{aligned}$$

2. Change the order of integration and hence evaluate  $\int_0^1 \int_x^{\sqrt{2-x^2}} \frac{x}{\sqrt{x^2+y^2}} dy dx$ .

**Solution**  $y = \sqrt{2-x^2}$

$$\Rightarrow y^2 = 2 - x^2$$

$$\Rightarrow x^2 + y^2 = 2$$

This circle and  $y = x$  meet if  $x^2 + x^2 = 2$

$$\therefore 2x^2 = 2 \Rightarrow x = 1$$

So, (1, 1) is the meeting point.

Now

$$\begin{aligned}
 I &= \int_0^1 \int_x^{\sqrt{2-x^2}} \frac{x}{\sqrt{x^2+y^2}} dy dx \\
 &= \int_{y=0}^{\sqrt{2}} \int_{x=0}^{\phi(y)} \frac{x}{\sqrt{x^2+y^2}} dx dy
 \end{aligned}$$

where  $\phi(y) = \begin{cases} y & \text{for } 0 \leq y \leq 1 \\ \sqrt{2-y^2} & \text{for } 1 \leq y \leq \sqrt{2} \end{cases}$

(Note that  $x = \phi(y)$  is the R.H.S. boundary of the shaded region)

So, the required integral is

$$\begin{aligned}
 I &= \int_{y=0}^1 \int_{x=0}^y \frac{x}{\sqrt{x^2+y^2}} dx dy + \int_{y=1}^{\sqrt{2}} \int_{x=0}^{\sqrt{2-y^2}} \frac{x}{\sqrt{x^2+y^2}} dx dy \\
 &= \int_0^1 [x^2 + y^2]_0^y dy + \int_1^{\sqrt{2}} [\sqrt{x^2+y^2}]_0^{\sqrt{2-y^2}} dy \\
 &= \int_0^1 (\sqrt{2} y - y) dy + \int_1^{\sqrt{2}} (\sqrt{2} - y) dy
 \end{aligned}$$

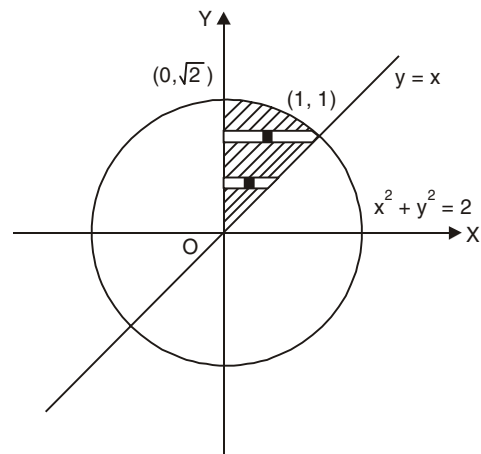

Fig. 3.11

$$\begin{aligned}
 &= \left[ (\sqrt{2}-1) \frac{y^2}{2} \right]_0^1 + \left[ \sqrt{2}y - \frac{y^2}{2} \right]_1^{\sqrt{2}} \\
 &= \frac{\sqrt{2}-1}{2} + \sqrt{2}(\sqrt{2}-1) - \left( \frac{2}{2} - \frac{1}{2} \right) \\
 &= 1 - \frac{1}{\sqrt{2}}.
 \end{aligned}$$

3. Change the order of integration and hence evaluate  $\int_0^{\infty} \int_x^{\infty} \frac{e^{-y}}{y} dy dx$ .

**Solution.** The region of integration is the portion of the first quadrant between  $y = x$  and the  $y$ -axis. So, by changing the order of integration.

$$\begin{aligned}
 \int_{x=0}^{\infty} \int_{y=x}^{\infty} \frac{e^{-y}}{y} dy dx &= \int_{y=0}^{\infty} \int_{x=0}^y \frac{e^{-y}}{y} dx dy \\
 &= \int_0^{\infty} \frac{e^{-y}}{y} [x]_0^y dy \\
 &= \int_0^{\infty} e^{-y} dy \\
 &= [-e^{-y}]_0^{\infty} = 1.
 \end{aligned}$$

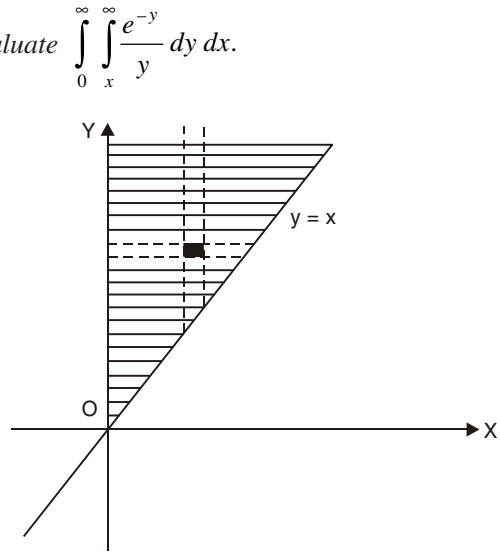

Fig. 3.12

4. Change the order of integration and hence evaluate  $\int_{y=0}^3 \int_{x=1}^{4-y} (x+y) dx dy$ .

**Solution**  $x = 4 - y \Rightarrow x + y = 4$

Limits for  $x$  are from 1 to  $4 - y$

when  $x = 1$  on  $x + y = 4$

we have  $1 + y = 4 \Rightarrow y = 3$

$$\text{So, } \int_0^3 \int_1^{4-y} (x+y) dx dy = \int_{x=1}^4 \int_0^{4-x} (x+y) dy dx$$

by changing the order of integration.

$$\begin{aligned}
 &= \int_1^4 \left[ xy + \frac{y^2}{2} \right]_0^{4-x} dx \\
 &= \int_1^4 \left[ x(4-x) + \frac{(4-x)^2}{2} \right] dx
 \end{aligned}$$

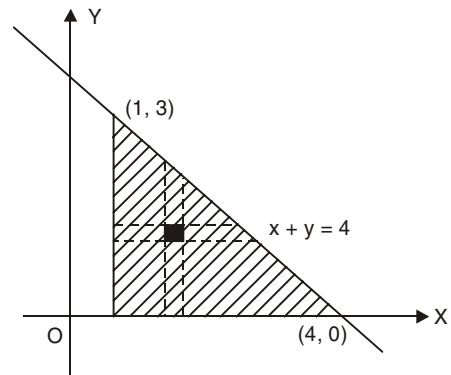

Fig. 3.13

$$= \int_1^4 \left( 8 - \frac{1}{2} x^2 \right) dx$$

$$= \left[ 8x - \frac{x^3}{6} \right]_1^4 = \frac{27}{2}.$$

5. Change the order of integration and hence evaluate  $\int_0^3 \int_1^{\sqrt{4-y}} (x+y) dx dy$ .

**Solution**

$$\Rightarrow \begin{aligned} x &= \sqrt{4-y} \\ x^2 &= 4-y \\ y &= 4-x^2, \text{ a parabola.} \end{aligned}$$

Here, the limits 1 and  $\sqrt{4-y}$  are for  $x$ , 0 and 3 are for  $y$ .

When  $x = 1$ , on  $y = 4 - x^2$ ,  $y = 3$

$$\text{Now, } \int_{y=0}^3 \int_{x=1}^{\sqrt{4-y}} (x+y) dx dy = \int_{x=1}^2 \int_{y=0}^{4-x^2} (x+y) dy dx$$

(By changing the order of integration)

$$= \int_1^2 \left[ xy + \frac{y^2}{2} \right]_0^{4-x^2} dx$$

$$= \int_1^2 \left( 4x - x^3 + 8 - 4x^2 + \frac{x^4}{2} \right) dx$$

$$= \left[ 2x^2 - \frac{x^4}{4} + 8x - \frac{4}{3}x^3 + \frac{x^5}{10} \right]_1^2$$

$$= 6 - \frac{15}{4} + 8 - \frac{28}{3} + \frac{31}{10} = \frac{241}{60}.$$

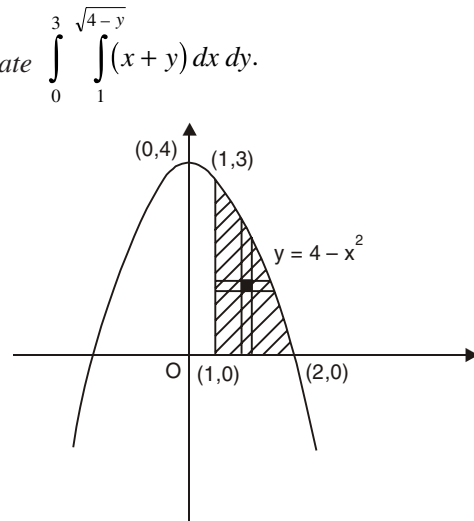

Fig. 3.14

### Type 3. Evaluation by changing into polars

1. Evaluate  $\int_0^{\infty} \int_0^{\infty} e^{-(x^2+y^2)} dx dy$  by changing to polar coordinates.

**Solution.** In polars we have  $x = r \cos \theta$ ,  $y = r \sin \theta$   
 $\therefore x^2 + y^2 = r^2$  and  $dx dy = r dr d\theta$

Since  $x, y$  varies from  $0$  to  $\infty$   
 $r$  also varies from  $0$  to  $\infty$   
 In the first quadrant ' $\theta$ '  
 varies from  $0$  to  $\pi/2$

Thus

$$I = \int_{\theta=0}^{\pi/2} \int_{r=0}^{\infty} e^{-r^2} r \, dr \, d\theta$$

Put

$$r^2 = t \quad \therefore r \, dr = \frac{dt}{2}$$

$t$  also varies from  $0$  to  $\infty$

$$\begin{aligned} I &= \int_{\theta=0}^{\pi/2} \int_{t=0}^{\infty} e^{-t} \frac{dt}{2} \, d\theta \\ &= \frac{1}{2} \int_{\theta=0}^{\pi/2} [-e^{-t}]_0^{\infty} \, d\theta \\ &= \frac{-1}{2} \int_0^{\pi/2} (0 - 1) \, d\theta \\ &= +\frac{1}{2} \int_0^{\pi/2} 1 \cdot d\theta \\ &= \frac{+1}{2} [\theta]_0^{\pi/2} = \frac{+1}{2} \cdot \frac{\pi}{2} = \frac{\pi}{4} \end{aligned}$$

2. Evaluate  $\int_0^a \int_0^{\sqrt{a^2-y^2}} y \sqrt{x^2+y^2} \, dx \, dy$  by changing into polars.

**Solution**

$$I = \int_{y=0}^a \int_{x=0}^{\sqrt{a^2-y^2}} y \sqrt{x^2+y^2} \, dx \, dy$$

$x = \sqrt{a^2 - y^2}$  or  $x^2 + y^2 = a^2$  is a circle with centre origin and radius  $a$ . Since,  $y$  varies from  $0$  to  $a$  the region of integration is the first quadrant of the circle.

In polars, we have  $x = r \cos \theta$ ,  $y = r \sin \theta$

$$\therefore x^2 + y^2 = r^2$$

$$\text{i.e., } r^2 = a^2$$

$$\Rightarrow r = a$$

Also  $x = 0, y = 0$  will give  $r = 0$  and hence we can say that  $r$  varies from  $0$  to  $a$ . In the first quadrant  $\theta$  varies from  $0$  to  $\pi/2$ , we know that  $dx \, dy = r \, dr \, d\theta$

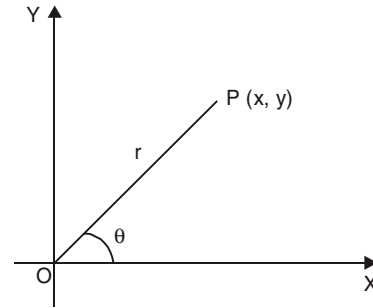

Fig. 3.15

$$\begin{aligned}
 \therefore I &= \int_{r=0}^a \int_{\theta=0}^{\pi/2} r \sin \theta \, r \, dr \, d\theta \\
 &= \int_{r=0}^a \int_{\theta=0}^{\pi/2} r^3 \sin \theta \, dr \, d\theta \\
 &= \int_{r=0}^a r^3 (-\cos \theta)_0^{\pi/2} \, dr \\
 &= \int_0^a -r^3 (0 - 1) \, dr = \left[ \frac{r^4}{4} \right]_0^a = \frac{a^4}{4} \\
 I &= \frac{a^4}{4}.
 \end{aligned}$$

#### Type 4. Applications of double and triple integrals

1. Find the area of the circle  $x^2 + y^2 = a^2$  by using double integral.

##### Solution

Since, the circle is symmetric about the coordinates axes, area of the circle is 4 times the area  $OAB$  as shown in Figure.

For the region  $OAB$ ,  $y$  varies from 0 to  $\sqrt{a^2 - x^2}$  and  $x$  varies from 0 to  $a$ .

$$\begin{aligned}
 \therefore \text{Area of the circle} &= 4 \int_0^a \int_{y=0}^{\sqrt{a^2 - x^2}} dy \, dx \\
 &= 4 \int_0^a [y]_{y=0}^{\sqrt{a^2 - x^2}} \, dx \\
 &= 4 \int_0^a \sqrt{a^2 - x^2} \, dx \\
 &= 4 \left[ \frac{x}{2} \sqrt{a^2 - x^2} + \frac{a^2}{2} \sin^{-1} \frac{x}{a} \right]_0^a = \pi a^2 \text{ sq. units}
 \end{aligned}$$

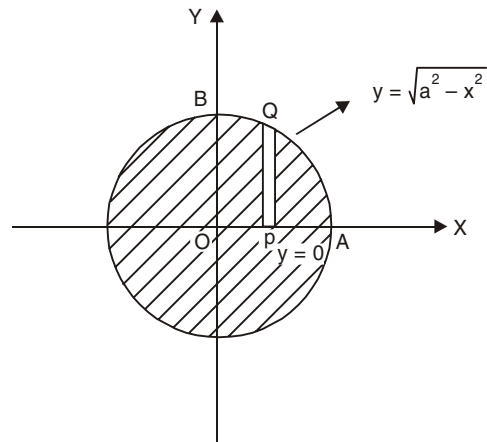

Fig. 3.16

2. Find by double integration the area enclosed by the curve  $r = a(1 + \cos \theta)$  between  $\theta = 0$  and  $\theta = \pi$ .

$$\text{Solution} \quad \text{Area} = \iint r \, dr \, d\theta$$

where  $r$  varies from 0 to  $a(1 + \cos \theta)$  and  $\theta$  varies from 0 to  $\pi$

$$\int \sqrt{a^2 - x^2} = \frac{x}{2} \sqrt{a^2 - x^2} + \frac{a^2}{2} \sin^{-1} \frac{x}{a}$$

*i.e.,*

$$\begin{aligned}
 A &= \int_{\theta=0}^{\pi} \int_{r=0}^{a(1+\cos\theta)} r \, dr \, d\theta \\
 &= \int_{\theta=0}^{\pi} \left[ \frac{r^2}{2} \right]_{r=0}^{a(1+\cos\theta)} d\theta \\
 &= \frac{1}{2} \int_0^{\pi} a^2 (1+\cos\theta)^2 d\theta \\
 &= \frac{a^2}{2} \int_0^{\pi} \left\{ 2 \cos^2 \left( \frac{\theta}{2} \right) \right\}^2 d\theta \\
 &= 2a^2 \int_0^{\pi} \cos^4 \left( \frac{\theta}{2} \right) d\theta
 \end{aligned}$$

Put  $\theta/2 = \phi, d\theta = 2d\phi$   
 and  $\phi$  varies from 0 to  $\pi/2$

$\therefore$

$$\begin{aligned}
 A &= 2a^2 \int_0^{\pi/2} \cos^4 \phi \cdot 2d\phi \\
 &= 4a^2 \int_0^{\pi/2} \cos^4 \phi \cdot d\phi \\
 &= 4a^2 \cdot \frac{3}{4} \cdot \frac{1}{2} \cdot \frac{\pi}{2} \quad (\text{by the reduction formula})
 \end{aligned}$$

Area,  $A = 3\pi a^2/4$  sq. units.

3. Find the value of  $\iiint_V z \, dx \, dy \, dz$  where  $V$  is the hemisphere  $x^2 + y^2 + z^2 = a^2, z \geq 0$ .

**Solution**

Let

$$\begin{aligned}
 I &= \iiint_V z \, dx \, dy \, dz \\
 &= \int_{x=-a}^a \int_{y=-\sqrt{a^2-x^2}}^{\sqrt{a^2-x^2}} \int_{z=0}^{\sqrt{a^2-x^2-y^2}} z \, dz \, dy \, dx \\
 &= \int_{x=-a}^a \int_{y=-\sqrt{a^2-x^2}}^{\sqrt{a^2-x^2}} \left[ \frac{z^2}{2} \right]_0^{\sqrt{a^2-x^2-y^2}} dy \, dx
 \end{aligned}$$

---

$$1 + \cos \theta = 2 \cos^2 \frac{\theta}{2}$$

$$\begin{aligned}
&= \frac{1}{2} \int_{x=-a}^a \int_{y=-\sqrt{a^2-x^2}}^{\sqrt{a^2-x^2}} (a^2 - x^2 - y^2) dy dx \\
&= \frac{1}{2} \int_{x=-a}^a \left[ (a^2 - x^2)y - \frac{y^3}{3} \right]_{y=-\sqrt{a^2-x^2}}^{\sqrt{a^2-x^2}} dx \\
&= \frac{1}{2} \cdot \frac{4}{3} \int_{-a}^a (a^2 - x^2)^{3/2} dx \\
&= \frac{2}{3} \cdot 2 \int_0^a (a^2 - x^2)^{3/2} dx
\end{aligned}$$

Put  $x = a \sin \theta$   
 $dx = a \cos \theta d\theta$

$\theta$  varies from 0 to  $\pi/2$

$$\begin{aligned}
&= \frac{4}{3} \int_{\theta=0}^{\pi/2} (a^2 \cos^2 \theta)^{3/2} a \cos \theta d\theta \\
&= \frac{4a^4}{3} \int_0^{\pi/2} \cos^4 \theta d\theta \\
&= \frac{4a^4}{3} \cdot \frac{3}{4} \cdot \frac{1}{2} \cdot \frac{\pi}{2} \quad \text{(By applying reduction formula)} \\
&= \frac{\pi a^4}{4}
\end{aligned}$$

Thus,  $I = \frac{\pi a^4}{4}$ .

4. Using multiple integrals find the volume of the ellipsoid  $\frac{x^2}{a^2} + \frac{y^2}{b^2} + \frac{z^2}{c^2} = 1$ .

**Solution**

The volume ( $V$ ) is 8 times in the first octant ( $V_1$ )

i.e.,  $V = 8V_1 = 8 \iiint dz dy dx$

$z$  varies from 0 to  $c \sqrt{1 - \frac{x^2}{a^2} - \frac{y^2}{b^2}}$

$y$  varies from 0 to  $(b/a) \sqrt{a^2 - x^2}$

$x$  varies from 0 to  $a$

$$\begin{aligned}
 V &= 8V_1 = 8 \int_{x=0}^a \int_{y=0}^{\sqrt{a^2-x^2}} \int_{z=0}^{c\sqrt{1-\frac{x^2}{a^2}-\frac{y^2}{b^2}}} dz dy dx \\
 &= 8 \int_{x=0}^a \int_{y=0}^{(b/a)\sqrt{a^2-x^2}} c\sqrt{1-\frac{x^2}{a^2}-\frac{y^2}{b^2}} dy dx \\
 &= 8c \int_{x=0}^a \int_{y=0}^{(b/a)\sqrt{a^2-x^2}} \frac{1}{b} \sqrt{b^2 \left\{ 1 - \left( \frac{x^2}{a^2} \right) \right\} - y^2} dy dx
 \end{aligned}$$

We shall use  $\int \sqrt{\alpha^2 - y^2} dy = \frac{y\sqrt{\alpha^2 - y^2}}{2} + \frac{\alpha^2}{2} \sin^{-1} \left( \frac{y}{\alpha} \right)$

where  $\alpha^2 = b^2 \{ 1 - x^2/a^2 \} = b^2 (a^2 - x^2)/a^2$

$$\begin{aligned}
 \therefore V &= \frac{8c}{b} \int_{x=0}^a \int_{y=0}^{\alpha} \sqrt{\alpha^2 - y^2} dy dx \\
 &= \frac{8c}{b} \int_{x=0}^a \left[ \frac{y\sqrt{\alpha^2 - y^2}}{2} + \frac{\alpha^2}{2} \sin^{-1} \left( \frac{y}{\alpha} \right) \right]_0^{\alpha} dx \\
 &= \frac{8c}{b} \int_{x=0}^a 0 + \frac{\alpha^2}{2} [\sin^{-1}(1) - \sin^{-1}(0)] dx \\
 &= \frac{8c}{b} \int_{x=0}^a \frac{\pi}{2} \cdot \frac{1}{2} \frac{b^2}{a^2} (a^2 - x^2) dx \\
 &= \frac{2bc\pi}{a^2} \left[ a^2x - \frac{x^3}{3} \right]_0^a \\
 &= \frac{2bc\pi}{a^2} \cdot \frac{2a^3}{3} = \frac{4\pi abc}{3}
 \end{aligned}$$

Thus the required volume ( $V$ ) =  $\frac{4\pi abc}{3}$  cubic units.



### EXERCISE 3.2

1. Evaluate  $\iint_R xy^2 dx dy$  over the region bounded by  $y = x^2$ ,  $y = 0$  and  $x = 1$ . [Ans.  $\frac{1}{24}$ ]
2. Evaluate  $\iint_R xy(x+y) dx dy$  taken over the region bounded by the parabolas  $y^2 = x$  and  $y = x^2$ . [Ans.  $\frac{3}{28}$ ]
3. Evaluate  $\iint_R x^2y dx dy$  over the region bounded by the curves  $y = x^2$  and  $y = x$ . [Ans.  $\frac{1}{35}$ ]
4. Evaluate  $\iint_R xy dx dy$  where  $R$  is the region in the first quadrant bounded by the line  $x + y = 1$ . [Ans.  $\frac{1}{6}$ ]

**Evaluate the following by changing the order of integration (5 to 9)**

5.  $\int_0^a \int_{\frac{x}{a}}^{\sqrt{\frac{x}{a}}} (x^2 + y^2) dy dx$ . [Ans.  $\frac{a^3}{28} + \frac{a}{20}$ ]
6.  $\int_0^a \int_0^{2\sqrt{ax}} x^2 dx dy$ . [Ans.  $\frac{4a^4}{7}$ ]
7.  $\int_{-a}^a \int_0^{\sqrt{a^2-x^2}} (a-x) dy dx$ . [Ans.  $\frac{\pi a^3}{2}$ ]
8.  $\int_0^a \int_{\sqrt{ax}}^a \frac{y^2 dy dx}{\sqrt{y^4 - a^2x^2}}$ . [Ans.  $\frac{\pi a^2}{6}$ ]
9.  $\int_0^a \int_{\frac{x^2}{a}}^{2a-x} xy dy dx$ . [Ans.  $\frac{3a^4}{8}$ ]
10. Evaluate  $\int_0^{2a} \int_0^{\sqrt{2ax-x^2}} x^2 dy dx$  by transforming into polar coordinates. [Ans.  $\frac{5\pi a^4}{8}$ ]
11. Find the area of the cardioid  $r = a(1 + \cos \theta)$  by double integration. [Ans.  $\frac{3\pi a^2}{2}$ ]
12. Find the volume of the region bounded by the cylinder  $x^2 + y^2 = 16$  and the planes  $z = 0$  and  $z = 3$ . [Ans.  $48\pi$ ]

### 3.4 BETA AND GAMMA FUNCTIONS

In this topic we define two special functions of improper integrals known as Beta function and Gamma function. These functions play important role in applied mathematics.

#### 3.4.1 Definitions

1. The Beta function denoted by  $B(m, n)$  or  $\beta(m, n)$  is defined by

$$\beta(m, n) = \int_0^1 x^{m-1} (1-x)^{n-1} dx, (m, n > 0) \quad \dots(1)$$

2. The Gamma function denoted by  $\Gamma(n)$  is defined by

$$\Gamma(n) = \int_0^{\infty} x^{n-1} \cdot e^{-x} dx \quad \dots(2)$$

#### 3.4.2 Properties of Beta and Gamma Functions

1.  $\beta(m, n) = \beta(n, m)$

$$2. \quad \beta(m, n) = \int_0^{\infty} \frac{x^{m-1}}{(1+x)^{m+n}} dx = \int_0^{\infty} \frac{x^{n-1}}{(1+x)^{m+n}} dx \quad \dots(3)$$

$$3. \quad \beta(m, n) = 2 \int_0^{\pi/2} \sin^{2m-1} \theta \cos^{2n-1} \theta d\theta \quad \dots(4)$$

$$= 2 \int_0^{\pi/2} \sin^{2n-1} \theta \cos^{2m-1} \theta d\theta$$

$$4. \quad \beta\left[\frac{p+1}{2}, \frac{q+1}{2}\right] = 2 \int_0^{\pi/2} \sin^p \theta \cos^q \theta d\theta$$

$$= 2 \int_0^{\pi/2} \sin^q \theta \cos^p \theta d\theta \quad \dots(5)$$

$$5. \quad \Gamma(n+1) = n \Gamma(n) \quad \dots(6)$$

6.  $\Gamma(n+1) = n!$ , if  $n$  is a +ve real number.

**Proof 1.** We have

$$\beta(m, n) = \int_0^1 x^{m-1} (1-x)^{n-1} dx$$

$$= \int_0^1 (1-x)^{m-1} [1-(1-x)]^{n-1} dx$$

$$\begin{aligned}
 \text{Since } \int_0^a f(x) dx &= \int_0^a f(a-x) dx \\
 &= \int_0^1 (1-x)^{m-1} (1-1+x)^{n-1} dx \\
 &= \int_0^1 x^{n-1} (1-x)^{m-1} dx \\
 &= \beta(n, m)
 \end{aligned}$$

$$\text{Thus, } \beta(m, n) = \beta(n, m)$$

Hence (1) is proved.

(2) By definition of Beta function,

$$\beta(m, n) = \int_0^1 x^{m-1} (1-x)^{n-1} dx$$

Substituting  $x = \frac{1}{1+t}$  then  $dx = \frac{-1}{(1+t)^2} dt$  when  $x = 0$ ,  $t = \infty$  and when  $x = 1$ ,  $t = 0$ .

Therefore,

$$\begin{aligned}
 \beta(m, n) &= \int_{\infty}^0 \left[ \frac{1}{1+t} \right]^{m-1} \left[ 1 - \frac{1}{1+t} \right]^{n-1} \left\{ \frac{-1}{(1+t)^2} dt \right\} \\
 &= \int_{\infty}^0 \left( \frac{1}{1+t} \right)^{m-1} \left( \frac{t}{1+t} \right)^{n-1} \left\{ \frac{-1}{(1+t)^2} dt \right\} \\
 &= \int_0^{\infty} \frac{t^{n-1}}{(1+t)^{m-1+n-1+2}} dt \\
 \beta(m, n) &= \int_0^{\infty} \frac{t^{n-1}}{(1+t)^{m+n}} dt = \int_0^{\infty} \frac{x^{n-1}}{(1+x)^{m+n}} dx
 \end{aligned}$$

$$\text{Similarly, } \beta(n, m) = \int_0^{\infty} \frac{x^{m-1}}{(1+x)^{m+n}} dx$$

Since,  $\beta(m, n) = \beta(n, m)$ , we get

$$\beta(m, n) = \int_0^{\infty} \frac{x^{n-1}}{(1+x)^{m+1}} dx = \int_0^{\infty} \frac{x^{m-1}}{(1+x)^{m+n}} dx$$

(3) By definition of Beta functions

$$\beta(m, n) = \int_0^1 x^{m-1} (1-x)^{n-1} dx$$

Substitute  $x = \sin^2 \theta$  then  $dx = 2 \sin \theta \cos \theta d\theta$

Also when  $x = 0, \theta = 0$

when  $x = 1, \theta = \frac{\pi}{2}$

$$\begin{aligned} \therefore \beta(m, n) &= \int_0^{\pi/2} (\sin^2 \theta)^{m-1} \cdot (1 - \sin^2 \theta)^{n-1} \cdot 2 \sin \theta \cos \theta d\theta \\ &= 2 \int_0^{\pi/2} \sin^{2m-2} \theta (\cos^2 \theta)^{n-1} \cdot \sin \theta \cos \theta d\theta \\ &= 2 \int_0^{\pi/2} \sin^{2m-2} \theta \cos^{2n-2} \theta \sin \theta \cos \theta d\theta \\ &= 2 \int_0^{\pi/2} \sin^{2m-1} \theta \cos^{2n-1} \theta d\theta \end{aligned}$$

Since,  $\beta(m, n) = \beta(n, m)$ , we have

$$\begin{aligned} \beta(m, n) &= 2 \int_0^{\pi/2} \sin^{2m-1} \theta \cos^{2n-1} \theta d\theta \\ &= 2 \int_0^{\pi/2} \sin^{2n-1} \theta \cos^{2m-1} \theta d\theta \end{aligned}$$

(4) Substituting  $2m - 1 = p$  and  $2n - 1 = q$

So that  $m = \frac{p+1}{2}, n = \frac{q+1}{2}$  in the above result, we have

$$\begin{aligned} \beta\left(\frac{p+1}{2}, \frac{q+1}{2}\right) &= 2 \int_0^{\pi/2} \sin^p \theta \cos^q \theta d\theta \\ &= 2 \int_0^{\pi/2} \sin^q \theta \cos^p \theta d\theta \end{aligned}$$

(1) Substituting  $q = 0$  in the above result, we get

$$\beta\left[\frac{p+1}{2}, \frac{1}{2}\right] = 2 \int_0^{\pi/2} \sin^p \theta d\theta = 2 \int_0^{\pi/2} \cos^p \theta d\theta.$$

(2) Substituting  $p = 0$  and  $q = 0$  in the above result

$$\beta\left(\frac{1}{2}, \frac{1}{2}\right) = 2 \int_0^{\pi/2} d\theta = \pi$$

(5) Replacing  $n$  by  $(n + 1)$  in the definition of gamma function.

$$\Gamma(n) = \int_0^{\infty} x^{n-1} \cdot e^{-x} dx$$

where  $n = (n + 1)$

$$\Gamma(n + 1) = \int_0^{\infty} x^n \cdot e^{-x} dx$$

On integrating by parts, we get

$$\begin{aligned} \Gamma(n + 1) &= \left[ x^n \cdot (-e^{-x}) \right]_0^{\infty} - \int_0^{\infty} (-e^{-x}) \cdot n x^{n-1} dx \\ &= 0 + n \int_0^{\infty} e^{-x} x^{n-1} dx = n \Gamma(n). \end{aligned}$$

$$\left[ \text{since } \lim_{x \rightarrow \infty} \frac{x^n}{e^x} = 0, \text{ if } n > 0 \right]$$

Thus,  $\Gamma(n + 1) = n \Gamma(n)$ , for  $n > 0$

This is called the recurrence formula, for the gamma function.

(6) If  $n$  is a positive integer then by repeated application of the above formula, we get

$$\begin{aligned} \Gamma(n + 1) &= n \Gamma(n) \\ &= n \Gamma(n - 1 + 1) \\ &= n(n - 1) \Gamma(n - 1) \text{ (using above result)} \\ &= n(n - 1)(n - 2) \Gamma(n - 2) \\ &\dots\dots\dots \\ &= n(n - 1)(n - 2)\dots\dots\dots 1\Gamma(1) \\ &= n! \Gamma(1) \end{aligned}$$

But 
$$\begin{aligned} \Gamma(1) &= \int_0^{\infty} x^0 e^{-x} dx \\ &= -\left[ e^{-x} \right]_0^{\infty} = -(0 - 1) = 1 \end{aligned}$$

Hence  $\Gamma(n + 1) = n!$ , if  $n$  is a positive integer.

For example

$$\Gamma(2) = 1! = 1, \Gamma(3) = 2! = 2, \Gamma(4) = 3! = 6$$

If  $n$  is a positive fraction then using the recurrence formula  $\Gamma(n + 1) = n \Gamma(n)$  can be evaluated as follows.

$$(1) \Gamma\left(\frac{3}{2}\right) = \Gamma\left(1 + \frac{1}{2}\right) = \frac{1}{2} \Gamma\left(\frac{1}{2}\right)$$

$$(2) \Gamma\left(\frac{5}{2}\right) = \Gamma\left(\frac{3}{2} + 1\right) = \frac{3}{2} \Gamma\left(\frac{3}{2}\right)$$

$$(3) \Gamma\left(\frac{7}{2}\right) = \Gamma\left(\frac{5}{2} + 1\right) = \frac{5}{2} \Gamma\left(\frac{5}{2}\right) \\ = \frac{5}{2} \cdot \frac{3}{2} \cdot \frac{1}{2} \cdot \Gamma\left(\frac{1}{2}\right) \\ = \frac{15}{8} \Gamma\left(\frac{1}{2}\right).$$

### 3.4.3 Relationship between Beta and Gamma functions

The Beta and Gamma functions are related by

$$\beta(m, n) = \frac{\Gamma(m)\Gamma(n)}{\Gamma(m+n)} \quad \dots(7)$$

**Proof.** We have  $\Gamma(n) = \int_0^{\infty} x^{n-1} \cdot e^{-x} dx$

Substituting  $x = t^2$ ,  $dx = 2t dt$ , we get

$$\Gamma(n) = \int_0^{\infty} (t^2)^{n-1} e^{-t^2} \cdot 2t dt \\ = 2 \int_0^{\infty} t^{2n-1} \cdot e^{-t^2} dt$$

$$\Gamma(n) = 2 \int_0^{\infty} x^{2n-1} e^{-x^2} dx \quad \dots(i)$$

Replacing  $n$  by  $m$ , and 'x' by 'y', we have

$$\Gamma(m) = 2 \int_0^{\infty} y^{2m-1} e^{-y^2} dy \quad \dots(ii)$$

Hence

$$\Gamma(m) \cdot \Gamma(n) = \left\{ 2 \int_0^{\infty} x^{2n-1} e^{-x^2} dx \right\} \left\{ 2 \int_0^{\infty} y^{2m-1} e^{-y^2} dy \right\} \\ = 4 \int_0^{\infty} \int_0^{\infty} x^{2n-1} e^{-x^2} y^{2m-1} \cdot e^{-y^2} dx dy$$

$$= 4 \int_0^{\infty} \int_0^{\infty} e^{-(x^2+y^2)} x^{2n-1} y^{2m-1} dx dy \quad \dots(iii)$$

We shall transform the double integral into polar coordinates.

Substitute  $x = r \cos \theta$ ,  $y = r \sin \theta$  then we have  $dx dy = r dr d\theta$

As  $x$  and  $y$  varies from 0 to  $\infty$ , the region of integration entire first quadrant. Hence,  $\theta$  varies from 0 to  $\frac{\pi}{2}$  and  $r$  varies from 0 to  $\infty$  and also  $x^2 + y^2 = r^2$

Hence (iii) becomes,

$$\begin{aligned} \Gamma(m) \Gamma(n) &= 4 \int_{r=0}^{\infty} \int_{\theta=0}^{\pi/2} e^{-r^2} (r \cos \theta)^{2n-1} (r \sin \theta)^{2m-1} \cdot r d\theta dr \\ &= 4 \int_{r=0}^{\infty} r^{2(m+n)-1} e^{-r^2} dr \times \int_0^{\pi/2} \sin^{2n-1} \theta \cos^{2m-1} \theta d\theta \quad \dots(iv) \end{aligned}$$

Substituting  $r^2 = t$ , in the first integral. We get,

$$\begin{aligned} \int_{r=0}^{\infty} r^{2(m+n)-1} e^{-r^2} dr &= \frac{1}{2} \int_0^{\infty} t^{m+n-1} e^{-t} dt \\ &= \frac{1}{2} \Gamma(m+n) \end{aligned}$$

and from (iv),  $\int_0^{\pi/2} \sin^{2m-1} \theta \cos^{2n-1} \theta d\theta = \frac{1}{2} \beta(m, n)$

Therefore (iv) reduces to  $\Gamma(m) \Gamma(n) = \Gamma(m+n) \beta(m, n)$

Thus,  $\beta(m, n) = \frac{\Gamma(m) \Gamma(n)}{\Gamma(m+n)}$ . **Hence proved.**

**Corollary.** To show that  $\Gamma\left(\frac{1}{2}\right) = \sqrt{\pi}$

Putting  $m = n = \frac{1}{2}$  in this result, we get

$$\beta\left[\frac{1}{2}, \frac{1}{2}\right] = \frac{\Gamma\left[\frac{1}{2}\right] \cdot \Gamma\left[\frac{1}{2}\right]}{\Gamma[1]}$$

But  $\Gamma(1) = 1$

$\therefore \beta\left[\frac{1}{2}, \frac{1}{2}\right] = \left\{\Gamma\left(\frac{1}{2}\right)\right\}^2 \quad \dots(8)$

Now consider  $\beta(m, n) = 2 \int_0^{\frac{\pi}{2}} \sin^{2m-1} \theta \cos^{2n-1} \theta d\theta$

Now we have from (8), L.H.S.

$$\beta\left[\frac{1}{2}, \frac{1}{2}\right] = 2 \int_0^{\frac{\pi}{2}} \sin^0 \theta \cos^0 \theta d\theta = 2 [\theta]_0^{\frac{\pi}{2}} = \pi$$

$$\pi = \Gamma\left\{\frac{1}{2}\right\}^2 \therefore \Gamma\left[\frac{1}{2}\right] = \sqrt{\pi}.$$

**WORKED OUT EXAMPLES**

1. Evaluate the following:

(i)  $\frac{\Gamma(7)}{\Gamma(5)}$

(ii)  $\frac{\Gamma(5/2)}{\Gamma(3/2)}$

(iii)  $\frac{\Gamma(8/3)}{\Gamma(2/3)}$

**Solution**

(i)  $\frac{\Gamma(7)}{\Gamma(5)} = \frac{6!}{4!} = 30$

(ii)  $\frac{\Gamma\left(\frac{5}{2}\right)}{\Gamma\left(\frac{3}{2}\right)} = \frac{\Gamma\left(\frac{3}{2}+1\right)}{\Gamma\left(\frac{3}{2}\right)} = \frac{\frac{3}{2}\Gamma\left(\frac{3}{2}\right)}{\Gamma\left(\frac{3}{2}\right)} = \frac{3}{2}$

(iii)  $\frac{\Gamma\left(\frac{8}{3}\right)}{\Gamma\left(\frac{2}{3}\right)} = \frac{\Gamma\left(\frac{5}{3}+1\right)}{\Gamma\left(\frac{2}{3}\right)} = \frac{\frac{5}{3}\Gamma\left(\frac{5}{3}\right)}{\Gamma\left(\frac{2}{3}\right)}$   
 $= \frac{\frac{5}{3}\Gamma\left(\frac{2}{3}+1\right)}{\Gamma\left(\frac{2}{3}\right)} = \frac{\frac{5}{3} \times \frac{2}{3}\Gamma\left(\frac{2}{3}\right)}{\Gamma\left(\frac{2}{3}\right)}$   
 $= \frac{10}{9}.$

2. Evaluate:

(i)  $\int_0^{\infty} x^4 e^{-x} dx$

(ii)  $\int_0^{\infty} x^6 e^{-3x} dx$

(iii)  $\int_0^{\infty} x^2 e^{-2x^2} dx.$



**Solution**

$$(i) \quad \int_0^{\infty} x^4 e^{-x} dx = \int_0^{\infty} x^{5-1} e^{-x} dx = \Gamma(5) = 4! \\ = 24$$

$$(ii) \quad \int_0^{\infty} x^6 e^{-3x} dx$$

Substituting  $3x = t \Rightarrow x = \frac{t}{3}$  then  $dx = \frac{dt}{3}$

$$\int_0^{\infty} x^6 e^{-3x} dx = \int_0^{\infty} \left(\frac{t}{3}\right)^6 \cdot e^{-t} \cdot \frac{dt}{3} \\ = \frac{1}{3^7} \int_0^{\infty} t^6 e^{-t} dt = \frac{1}{3^7} \int_0^{\infty} t^{7-1} e^{-t} dt \\ = \frac{1}{3^7} \Gamma(7) \\ = \frac{1}{3^7} 6! = \frac{80}{243}$$

(iii) Substitute  $2x^2 = t \Rightarrow x^2 = \frac{t}{2} \Rightarrow x = \sqrt{\frac{t}{2}}$

Then  $2x dx = \frac{dt}{2}$

$$dx = \frac{dt}{4x} = \frac{\sqrt{2} dt}{4\sqrt{t}}$$

$$\int_0^{\infty} x^2 e^{-2x^2} dx = \int_0^{\infty} \frac{t}{2} \cdot e^{-t} \cdot \frac{\sqrt{2}}{4\sqrt{t}} dt$$

$$= \frac{\sqrt{2}}{8} \int_0^{\infty} t^{\frac{1}{2}} e^{-t} dt$$

$$= \frac{\sqrt{2}}{8} \int_0^{\infty} t^{\frac{3}{2}-1} e^{-t} dt$$

$$= \frac{\sqrt{2}}{8} \Gamma\left(\frac{3}{2}\right)$$

$$= \frac{\sqrt{2}}{8} \Gamma\left(\frac{1}{2} + 1\right) = \frac{\sqrt{2}}{8} \cdot \frac{1}{2} \Gamma\left(\frac{1}{2}\right)$$

$$= \frac{\sqrt{2}}{8} \cdot \frac{1}{2} \sqrt{\pi} = \frac{\sqrt{2\pi}}{16}$$

$$\left[ \because \Gamma\left(\frac{1}{2}\right) = \sqrt{\pi} \right]$$

3. Evaluate the following:

$$(i) \int_0^{\infty} \sqrt{x} e^{-x^3} dx$$

$$(ii) \int_0^{\infty} x^4 e^{-x^2} dx$$

$$(iii) \int_0^{\infty} x^{\frac{1}{4}} e^{-\sqrt{x}} dx$$

$$(iv) \int_0^{\infty} x^{\frac{-3}{2}} (1 - e^{-x}) dx$$

$$(v) \int_0^{\infty} 3^{-4x^2} dx.$$

**Solution**

(i) Substitute  $x^3 = t$  so that  $3x^2 dx = dt$

where  $x = t^{\frac{1}{3}}, dx = \frac{dt}{3t^{\frac{2}{3}}}$

when  $x = 0, t = 0$  and when  $x = \infty, t = \infty$

Hence, 
$$\begin{aligned} \int_0^{\infty} \sqrt{x} e^{-x^3} dx &= \int_0^{\infty} t^{\frac{1}{6}} e^{-t} \frac{dt}{3t^{\frac{2}{3}}} \\ &= \frac{1}{3} \int_0^{\infty} t^{\frac{-1}{2}} e^{-t} dt \\ &= \frac{1}{3} \int_0^{\infty} t^{\frac{1}{2}-1} e^{-t} dt \\ &= \frac{1}{3} \Gamma\left(\frac{1}{2}\right) = \frac{1}{3} \sqrt{\pi}. \end{aligned}$$

(ii) Substitute,  $x^2 = t \Rightarrow x = t^{\frac{1}{2}} = \sqrt{t}$

So that  $2x dx = dt \Rightarrow dx = \frac{dt}{2\sqrt{t}}$

Hence, 
$$\begin{aligned} \int_0^{\infty} x^4 e^{-x^2} dx &= \int_0^{\infty} t^2 e^{-t} \frac{dt}{2\sqrt{t}} \\ &= \frac{1}{2} \int_0^{\infty} t^{\frac{3}{2}} e^{-t} dt \\ &= \frac{1}{2} \int_0^{\infty} t^{\frac{5}{2}-1} e^{-t} dt \\ &= \frac{1}{2} \Gamma\left(\frac{5}{2}\right) \\ &= \frac{1}{2} \cdot \frac{3}{2} \cdot \frac{1}{2} \Gamma\left(\frac{1}{2}\right) = \frac{3}{8} \sqrt{\pi}. \end{aligned}$$

(iii) Substitute,  $\sqrt{x} = t \Rightarrow x = t^2, dx = 2t dt$

$$\begin{aligned} \text{Hence, } \int_0^{\infty} x^{\frac{1}{4}} e^{-\sqrt{x}} dx &= \int_0^{\infty} t^{1/2} e^{-t} 2t dt \\ &= 2 \int_0^{\infty} t^{\frac{3}{2}} e^{-t} dt \\ &= 2 \int_0^{\infty} t^{\frac{5}{2}-1} e^{-t} dt \\ &= 2 \Gamma\left(\frac{5}{2}\right) \\ &= 2 \cdot \frac{3}{2} \cdot \frac{1}{2} \Gamma\left(\frac{1}{2}\right) = \frac{3}{2} \sqrt{\pi}. \end{aligned}$$

(iv) On integrating by parts, we get

$$\begin{aligned} \int_0^{\infty} x^{\frac{-3}{2}} (1 - e^{-x}) dx &= \left[ (1 - e^{-x}) \left( -2x^{\frac{-1}{2}} \right) \right]_0^{\infty} - \int_0^{\infty} \left( -2x^{\frac{-1}{2}} \right) e^{-x} dx \\ &= 0 + 2 \int_0^{\infty} x^{\frac{-1}{2}} e^{-x} dx \\ &= 2 \int_0^{\infty} x^{\frac{1}{2}-1} e^{-x} dx \\ &= 2 \Gamma\left(\frac{1}{2}\right) \\ &= 2 \sqrt{\pi}. \end{aligned}$$

(v) Since  $a = e^{\log a}, a > 0$ , we have

$$3^{-4x^2} = [e^{\log 3}]^{-4x^2} = e^{-(4 \log 3)x^2}$$

$$\int_0^{\infty} e^{-4x^2} dx = \int_0^{\infty} e^{-(4 \log 3)x^2} dx$$

Setting  $(4 \log 3) x^2 = t$  we get,

$$x^2 = \frac{t}{4 \log 3} \Rightarrow x = \frac{\sqrt{t}}{2\sqrt{\log 3}}$$

$$(4 \log 3) 2x dx = dt$$

$$(4 \log 3) 2 \cdot \frac{\sqrt{t}}{2\sqrt{\log 3}} dx = dt$$

$$\sqrt{t} \cdot 4\sqrt{\log 3} \, dx = dt \quad \Rightarrow \quad dx = \frac{1}{\sqrt{t} \cdot 4\sqrt{\log 3}} \, dt$$

$$\begin{aligned} \int_0^{\infty} 3^{-4x^2} \, dx &= \int_0^{\infty} e^{-t} \cdot \frac{1}{\sqrt{t} \cdot 4\sqrt{\log 3}} \, dt \\ &= \frac{1}{4\sqrt{\log 3}} \int_0^{\infty} t^{-\frac{1}{2}} e^{-t} \, dt \\ &= \frac{1}{4\sqrt{\log 3}} \int_0^{\infty} t^{\frac{1}{2}-1} e^{-t} \, dt \\ &= \frac{1}{4\sqrt{\log 3}} \Gamma\left(\frac{1}{2}\right) \end{aligned}$$

$$\int_0^{\infty} 3^{-4x^2} \, dx = \frac{\sqrt{\pi}}{4\sqrt{\log 3}}$$

4. Evaluate:

(i)  $\int_0^1 (\log x)^4 \, dx$

(ii)  $\int_0^1 (x \log x)^3 \, dx$

(iii)  $\int_0^1 \frac{dx}{\sqrt{\log\left(\frac{1}{x}\right)}}$

**Solution**

Substitute  $\log x = -t$  so that  $x = e^{-t}$

Also  $\frac{1}{x} dx = -dt$  or  $dx = -x \, dt = -e^{-t} \, dt$

when  $x = 0$ ,  $t = -\log 0 = \infty$  and

when  $x = 1$ ,  $t = -\log 1 = 0$  (note that  $\log 0 = -\infty$ )

(i) Hence 
$$\begin{aligned} \int_0^1 (\log x)^4 \, dx &= \int_{\infty}^0 (-t)^4 \cdot -e^{-t} \, dt \\ &= \int_0^{\infty} t^4 e^{-t} \, dt \\ &= \int_0^{\infty} t^{5-1} e^{-t} \, dt \\ &= \Gamma(5) = 4! = 24. \end{aligned}$$

(ii) 
$$\begin{aligned} \int_0^1 (x \log x)^3 \, dx &= \int_{\infty}^0 [e^{-1} (-t)]^3 (-e^{-t} \, dt) \\ &= -\int_0^{\infty} t^3 e^{-4t} \, dt \end{aligned}$$

$$\begin{aligned} \text{Put} \quad 4t = u & \Rightarrow 4dt = du \\ & dt = \frac{1}{4} du \end{aligned}$$

$$\begin{aligned} \therefore \int_0^1 (x \log x)^3 dx &= - \int \left(\frac{u}{4}\right)^3 \cdot e^{-u} \cdot \frac{1}{4} du \\ &= \frac{-1}{(4)^4} \int_0^\infty u^3 \cdot e^{-u} du \\ &= \frac{-1}{256} \int_0^\infty u^{4-1} e^{-u} du \\ &= \frac{-1}{256} \Gamma(4) = -\frac{3!}{256} = \frac{-3}{128}. \end{aligned}$$

$$\begin{aligned} \text{(iii)} \quad \int_0^1 \frac{1}{\sqrt{\log\left(\frac{1}{x}\right)}} dx &= \int_\infty^0 \frac{-e^{-t} dt}{\sqrt{t}} \\ &= \int_0^\infty t^{-\frac{1}{2}} e^{-t} dt \\ &= \int_0^\infty t^{\frac{1}{2}-1} e^{-t} dt \\ &= \Gamma\left(\frac{1}{2}\right) = \sqrt{\pi}. \end{aligned}$$

5. Prove that  $\int_0^\infty a^{-bx^2} dx = \frac{\sqrt{\pi}}{2\sqrt{b \log a}}$  where  $a$  and  $b$  are positive constants.

**Solution**

$$\begin{aligned} \text{Now,} \quad \int_0^\infty a^{-bx^2} dx &= \int_0^\infty \{e^{\log a}\}^{-bx^2} \text{ since } a = e^{\log a} \\ &= \int_0^\infty e^{-(b \log a)x^2} dx \end{aligned}$$

$$\text{Substitute} \quad (b \log a) x^2 = t, \quad dx = \frac{dt}{(b \log a) \cdot 2x}$$

$$\text{So that,} \quad x = \frac{\sqrt{t}}{\sqrt{b \log a}}$$

$$\therefore dx = \frac{dt}{2\sqrt{t} \sqrt{b \log a}}$$

$$\int_0^\infty e^{-bx^2} dx = \int_0^\infty e^{-t} \cdot \frac{dt}{2\sqrt{t} \sqrt{b \log a}}$$

$$\begin{aligned}
 &= \frac{1}{2\sqrt{b \log a}} \int_0^\infty t^{\frac{-1}{2}} e^{-t} dt \\
 &= \frac{1}{2\sqrt{b \log a}} \int_0^\infty t^{\frac{1}{2}-1} e^{-t} dt \\
 &= \frac{1}{2\sqrt{b \log a}} \Gamma\left(\frac{1}{2}\right) \\
 &= \frac{\sqrt{\pi}}{2\sqrt{b \log a}}.
 \end{aligned}$$

6. Prove that  $\int_0^\infty x^m e^{-ax^n} dx = \frac{1}{na^{\frac{m+1}{n}}} \Gamma\left(\frac{m+1}{n}\right)$ , where  $m$  and  $n$  are positive constants.

**Solution**

Substitute  $ax^n = t$  so that  $x = \left(\frac{t}{a}\right)^{\frac{1}{n}}$

Then  $dx = \frac{1}{na^{\frac{1}{n}}} \cdot t^{\frac{1}{n}-1} dt$

Therefore,

$$\begin{aligned}
 \int_0^\infty x^m e^{-ax^n} dx &= \int_0^\infty \left[\left(\frac{t}{a}\right)^{\frac{1}{n}}\right]^m e^{-t} \cdot \frac{t^{\frac{1}{n}-1}}{na^{\frac{1}{n}}} dt \\
 &= \frac{1}{na^{\frac{(m+1)}{n}}} \int_0^\infty t^{\frac{(m+1)}{n}-1} e^{-t} dt \\
 &= \frac{1}{na^{\frac{(m+1)}{n}}} \Gamma\left[\frac{m+1}{n}\right].
 \end{aligned}$$

7. Prove that  $\int_0^1 x^m (\log x)^n dx = \frac{(-1)^n \cdot n!}{(m+1)^{n+1}}$ , where  $n$  is a positive integer and  $m > -1$ .

**Solution**

Substitute  $\log x = -t$  or  $x = e^{-t}$

Then  $dx = -e^{-t} dt$

when  $x = 0$ ,  $t = \infty$  and when  $x = 1$ ,  $t = 0$ .

Therefore,

$$\int_0^1 x^m (\log x)^n dx = \int_\infty^0 (e^{-t})^m (-t)^n \cdot (-e^{-t}) dt$$

$$\begin{aligned}
 &= (-1)^n \int_0^{\infty} t^n e^{-(m+1)t} dt \\
 &= (-1)^n \int_0^{\infty} \left\{ \frac{u}{m+1} \right\}^n e^{-u} \cdot \frac{du}{m+1}
 \end{aligned}$$

since setting

$$(m+1)t = u$$

$$\begin{aligned}
 &= \frac{(-1)^n}{(m+1)^{n+1}} \int_0^{\infty} u^n e^{-u} du \\
 &= \frac{(-1)^n}{(m+1)^{n+1}} \int_0^{\infty} u^{(n+1-1)} e^{-u} du \\
 &= \frac{(-1)^n}{(m+1)^{n+1}} \Gamma(n+1) \\
 &= \frac{(-1)^n n!}{(m+1)^{n+1}} \text{ where } \Gamma(n+1) = n!.
 \end{aligned}$$

8. Prove that

$$(i) \int_0^{\infty} x^{n-1} e^{-ax} \cos bx dx = \frac{\Gamma(n)}{(a^2 + b^2)^{\frac{n}{2}}} \cos \left\{ n \tan^{-1} \frac{b}{a} \right\}$$

$$(ii) \int_0^{\infty} x^{n-1} e^{-ax} \sin bx dx = \frac{\Gamma(n)}{(a^2 + b^2)^{\frac{n}{2}}} \sin \left\{ n \tan^{-1} \frac{b}{a} \right\}.$$

**Solution**

Consider

$$\begin{aligned}
 I &= \int_0^{\infty} x^{n-1} e^{-ax} e^{ibx} dx \\
 &= \int_0^{\infty} x^{n-1} e^{-(a-ib)x} dx
 \end{aligned}$$

Substitute  $(a-ib)x = t$ , so that  $dx = \frac{dt}{a-ib}$

$$x = \frac{t}{a-ib}$$

Hence,

$$\begin{aligned}
 I &= \int_0^{\infty} \left\{ \frac{t}{a-ib} \right\}^{n-1} e^{-t} \cdot \frac{dt}{a-ib} \\
 &= \frac{1}{(a-ib)^n} \int_0^{\infty} t^{n-1} e^{-t} dt \\
 &= \frac{1}{(a-ib)^n} \Gamma(n)
 \end{aligned}$$

$$I = \frac{(a + ib)^n \cdot \Gamma(n)}{(a^2 + b^2)^n} \quad \dots(1)$$

Since  $a + ib = r (\cos \theta + i \sin \theta)$

where  $r = \sqrt{a^2 + b^2}$  and  $\theta = \tan^{-1} \left( \frac{b}{a} \right)$

Hence (1) reduces to,

$$I = \frac{\Gamma(n) [r (\cos \theta + i \sin \theta)]^n}{(a^2 + b^2)^n}$$

Apply De Moivre's theorem

$$\begin{aligned} &= \frac{\Gamma(n) r^n (\cos n \theta + i \sin n \theta)}{(a^2 + b^2)^n} \\ &= \frac{\Gamma(n) \cdot (a^2 + b^2)^{n/2} (\cos n \theta + i \sin n \theta)}{(a^2 + b^2)^n} \\ &= \frac{\Gamma(n)}{(a^2 + b^2)^{n/2}} (\cos n \theta + i \sin n \theta) \end{aligned}$$

On equating the real and imaginary parts, we get

$$\begin{aligned} (i) \quad \int_0^{\infty} x^{n-1} e^{-ax} \cos bx \, dx &= \frac{\Gamma(n)}{(a^2 + b^2)^{n/2}} \cos n \theta \\ (ii) \quad \int_0^{\infty} x^{n-1} e^{-ax} \sin bx \, dx &= \frac{\Gamma(n)}{(a^2 + b^2)^{n/2}} \sin n \theta \end{aligned}$$

where  $\theta = \tan^{-1} \frac{b}{a}$ .

**9. Evaluate**

- (i)  $\beta (3, 5)$       (ii)  $\beta (3/2, 2)$       (iii)  $\beta (1/3, 2/3)$ .

**Solution**

Using the relation  $\beta (m, n) = \frac{\Gamma(m) \Gamma(n)}{\Gamma(m+n)}$

$$(i) \quad \beta (3, 5) = \frac{\Gamma(3) \Gamma(5)}{\Gamma(3+5)} = \frac{2! 4!}{7!} = \frac{1}{105}$$



$$(ii) \quad \beta\left[\frac{3}{2}, 2\right] = \frac{\Gamma\left(\frac{3}{2}\right)\Gamma(2)}{\Gamma\left(\frac{3}{2}+2\right)} = \frac{\Gamma\left(\frac{3}{2}\right)\Gamma(2)}{\Gamma\left(\frac{7}{2}\right)}$$

$$= \frac{\frac{1}{2}\Gamma\left(\frac{1}{2}\right) \cdot 1!}{\frac{5}{2} \cdot \frac{3}{2} \cdot \frac{1}{2}\Gamma\left(\frac{1}{2}\right)} = \frac{4}{15}$$

$$(iii) \quad \beta\left(\frac{1}{3}, \frac{2}{3}\right) = \frac{\Gamma\left(\frac{1}{3}\right) \cdot \Gamma\left(\frac{2}{3}\right)}{\Gamma\left(\frac{1}{3} + \frac{2}{3}\right)}$$

$$= \Gamma\left(\frac{1}{3}\right) \Gamma\left(1 - \frac{1}{3}\right)$$

where  $\Gamma(n) \Gamma(1 - n) = \frac{\pi}{\sin n \pi}$

$$= \frac{\pi}{\sin \frac{\pi}{3}}$$

$$= \frac{2\pi}{\sqrt{3}}$$

10. Evaluate each of the following integrals

$$(i) \int_0^1 x^4 (1 - x^3) dx$$

$$(ii) \int_0^2 \frac{x^2}{\sqrt{2-x}} dx$$

$$(iii) \int_0^a y^4 \sqrt{a^2 - y^2} dy$$

$$(iv) \int_0^1 \sqrt{\frac{1-x}{x}} dx$$

$$(v) \int_0^2 (4 - x^2)^{3/2} dx$$

**Solution**

$$(i) \int_0^1 x^4 (1 - x^3) dx = \beta(5, 4) = \frac{\Gamma(5)\Gamma(4)}{\Gamma(5+4)} = \frac{4!3!}{8!} = \frac{1}{280}$$

(ii) Substitute  $x = 2t$

Then  $dx = 2dt$

$$\therefore \int_0^2 \frac{x^2}{\sqrt{2-x}} dx = \int_0^1 \frac{4t^2}{\sqrt{2-2t}} 2 dt$$

$$= 4\sqrt{2} \int_0^1 t^2 (1-t)^{-1/2} dt$$

$$= 4\sqrt{2} \beta\left[3, \frac{1}{2}\right]$$

$$= 4\sqrt{2} \frac{\Gamma(3) \Gamma\left(\frac{1}{2}\right)}{\Gamma\left[3 + \frac{1}{2}\right]}$$

$$\equiv \frac{64\sqrt{2}}{15} \frac{\Gamma(3) \Gamma\left(\frac{1}{2}\right)}{\Gamma\left(\frac{7}{2}\right)}$$

(iii) Substitute

$$y^2 = a^2 t$$

or

$$y = a \sqrt{t}$$

$$dy = \frac{a}{2\sqrt{t}} dt$$

Given integral becomes,

$$\int_0^1 (a \sqrt{t})^4 \sqrt{a^2 - a^2 t} \frac{a}{2\sqrt{t}} dt = \frac{a^6}{2} \int_0^1 t^{3/2} (1-t)^{1/2} dt$$

$$= \frac{a^6}{2} \beta\left[\frac{5}{2}, \frac{3}{2}\right]$$

$$= \frac{a^6}{2} \frac{\Gamma\left(\frac{5}{2}\right) \cdot \Gamma\left(\frac{3}{2}\right)}{\Gamma\left(\frac{5}{2} + \frac{3}{2}\right)} = \frac{\pi a^6}{32}$$

$$(iv) \int_0^1 \sqrt{\frac{1-x}{x}} dx = \int_0^1 x^{-1/2} (1-x)^{1/2} dx$$

$$= \beta\left(\frac{1}{2}, \frac{3}{2}\right) = \frac{\Gamma\left(\frac{1}{2}\right) \cdot \Gamma\left(\frac{3}{2}\right)}{\Gamma\left(\frac{1}{2} + \frac{3}{2}\right)} = \frac{\pi}{2}$$

(v) Substitute

$$x^2 = 4t$$

or

$$x = 2\sqrt{t}$$

then 
$$dx = \frac{dt}{\sqrt{t}}$$

Given integral reduces to,

$$\begin{aligned} \int_0^1 (4-4t)^{3/2} \frac{dt}{\sqrt{t}} &= 8 \int_0^1 t^{-1/2} (1-t)^{3/2} dt \\ &= 8 \beta \left[ \frac{1}{2}, \frac{5}{2} \right] \\ &= 8 \frac{\Gamma\left(\frac{1}{2}\right) \Gamma\left(\frac{5}{2}\right)}{\Gamma(3)} \\ &= \frac{8 \sqrt{\pi} \cdot \frac{3}{2} \cdot \frac{1}{2} \Gamma\left(\frac{1}{2}\right)}{2} \\ &= 3 \pi. \end{aligned}$$

11. Evaluate each of the following integrals:

(i)  $\int_0^{\pi/2} \sin^6 \theta d\theta$

(ii)  $\int_0^{\pi} \cos^4 \theta d\theta$

(iii)  $\int_0^{\pi/2} \sin^4 \theta \cos^5 \theta d\theta$

(iv)  $\int_0^{\pi/2} \sin^{1/2} \theta \cos^{3/2} \theta d\theta$

(v)  $\int_0^{\pi/2} \sqrt{\tan \theta} d\theta.$

**Solution**

From the relation

$$\beta \left( \frac{p+1}{2}, \frac{q+1}{2} \right) = 2 \int_0^{\pi/2} \sin^p \theta \cos^q \theta d\theta$$

$$\therefore \int_0^{\pi/2} \sin^p \theta \cos^q \theta d\theta = \frac{1}{2} \beta \left[ \frac{p+1}{2}, \frac{q+1}{2} \right]$$

(i) Taking  $p = 6$   
 $q = 0$

we get 
$$\begin{aligned} \int_0^{\pi/2} \sin^6 \theta d\theta &= \frac{1}{2} \beta \left[ \frac{6+1}{2}, \frac{0+1}{2} \right] \\ &= \frac{1}{2} \beta \left[ \frac{7}{2}, \frac{1}{2} \right] \end{aligned}$$

$$\begin{aligned}
 &= \frac{1}{2} \frac{\Gamma\left(\frac{7}{2}\right) \cdot \Gamma\left(\frac{1}{2}\right)}{\Gamma(4)} = \frac{5\pi}{32}. \\
 (ii) \quad \int_0^{\pi} \cos^4 \theta \, d\theta &= 2 \int_0^{\pi/2} \cos^4 \theta \, d\theta = 2 \cdot \frac{1}{2} \beta\left[\frac{0+1}{2}, \frac{4+1}{2}\right] \\
 &= \beta\left[\frac{1}{2}, \frac{5}{2}\right] = \frac{\Gamma\left(\frac{1}{2}\right) \Gamma\left(\frac{5}{2}\right)}{\Gamma(3)} = \frac{3\pi}{8}.
 \end{aligned}$$

(iii) Here  $p = 4$   
 $q = 3$  from the above relation

$$\begin{aligned}
 \int_0^{\pi/2} \sin^4 \theta \cos^5 \theta \, d\theta &= \frac{1}{2} \beta\left[\frac{4+1}{2}, \frac{5+1}{2}\right] \\
 &= \frac{1}{2} \beta\left[\frac{5}{2}, 3\right] \\
 &= \frac{1}{2} \frac{\Gamma\left(\frac{5}{2}\right) \Gamma(3)}{\Gamma\left(\frac{11}{2}\right)} = \frac{8}{315}
 \end{aligned}$$

(iv) Here  $p = \frac{1}{2}$ ,  $q = \frac{3}{2}$

$$\begin{aligned}
 \int_0^{\pi/2} \sin^{1/2} \theta \cos^{3/2} \theta \, d\theta &= \frac{1}{2} \beta\left[\frac{\frac{1}{2}+1}{2}, \frac{\frac{3}{2}+1}{2}\right] \\
 &= \frac{1}{2} \beta\left[\frac{3}{4}, \frac{5}{4}\right] \\
 &= \frac{1}{2} \frac{\Gamma\left(\frac{3}{4}\right) \Gamma\left(\frac{1}{4}\right)}{1} \\
 &= \frac{1}{8} \Gamma\left(1 - \frac{1}{4}\right) \Gamma\left(\frac{1}{4}\right) \\
 &= \frac{1}{8} \frac{\pi}{\sin \frac{\pi}{4}} \quad \left(\text{where } \Gamma(n) \Gamma(1-n) = \frac{\pi}{\sin n\pi}\right) \\
 &= \frac{\sqrt{2} \pi}{8}.
 \end{aligned}$$

$$\begin{aligned}
 (v) \quad \int_0^{\pi/2} \sqrt{\tan \theta} \, d\theta &= \int_0^{\pi/2} \frac{\sqrt{\sin \theta}}{\sqrt{\cos \theta}} \, d\theta = \int_0^{\pi/2} \sin^{1/2} \theta \cos^{-1/2} \theta \, d\theta \\
 &= \frac{1}{2} \beta \left[ \frac{\frac{1}{2} + 1}{2}, \frac{\frac{-1}{2} + 1}{2} \right] = \frac{1}{2} \beta \left[ \frac{3}{4}, \frac{1}{4} \right] \\
 &= \frac{1}{2} \frac{\Gamma\left(\frac{3}{4}\right) \Gamma\left(\frac{1}{4}\right)}{\Gamma(1)} \\
 &= \frac{1}{2} \Gamma\left(1 - \frac{1}{4}\right) \Gamma\left(\frac{1}{4}\right) \\
 &= \frac{1}{2} \cdot \frac{\pi}{\sin \frac{\pi}{4}} = \frac{\pi}{\sqrt{2}}.
 \end{aligned}$$

12. Evaluate: (i)  $\int_0^{\infty} \frac{x \, dx}{1+x^6}$       (ii)  $\int_0^{\infty} \frac{y^2 \, dy}{1+y^4}$ .

**Solution**

(i) Let  $x^6 = t$  or  $x = t^{1/6}$

$$dx = \frac{1}{6} t^{-5/6} dt$$

The given integral becomes,

$$\begin{aligned}
 \int_0^{\infty} \frac{t^{\frac{1}{6}} \left(\frac{1}{6}\right) t^{-\frac{5}{6}} dt}{1+t} &= \frac{1}{6} \int_0^{\infty} \frac{t^{-\frac{2}{3}}}{1+t} dt \\
 &= \frac{1}{6} \int_0^{\infty} \frac{t^{\frac{1}{3}-1}}{(1+t)^{2/3+1/3}} dt \\
 &= \frac{1}{6} \beta \left[ \frac{1}{3}, \frac{2}{3} \right]
 \end{aligned}$$

$$\left[ \text{Using the relation, } \beta(m, n) = \int_0^{\infty} \frac{x^{m-1}}{(1+x)^{m+n}} dx = \int_0^{\infty} \frac{x^{n-1}}{(1+x)^{m+n}} dx \right]$$

$$\begin{aligned}
&= \frac{1}{6} \frac{\Gamma\left(\frac{1}{3}\right) \Gamma\left(\frac{2}{3}\right)}{\Gamma(1)} \\
&= \frac{1}{6} \Gamma\left(\frac{1}{3}\right) \cdot \Gamma\left(1 - \frac{1}{3}\right) \\
&= \frac{1}{6} \cdot \frac{\pi}{\sin\left(\frac{\pi}{3}\right)} = \frac{\pi}{3\sqrt{3}}.
\end{aligned}$$

(ii) Substituting

$$y^4 = t, \text{ or } y = t^{1/4}$$

then

$$dy = \frac{1}{4} t^{-3/4} dt$$

so that,

$$\begin{aligned}
\int_0^{\infty} \frac{y^2 dy}{1+y^4} &= \int_0^{\infty} \frac{\left(\frac{1}{t^4}\right)^2 \left(\frac{1}{4}\right) t^{-3/4} dt}{1+t} \\
&= \frac{1}{4} \int_0^{\infty} \frac{t^{-1/4}}{1+t} dt \\
&= \frac{1}{4} \int_0^{\infty} \frac{t^{3/4-1}}{(1+t)^{3/4+1/4}} dt \\
&= \frac{1}{4} \beta\left[\frac{3}{4}, \frac{1}{4}\right] \\
&= \frac{1}{4} \frac{\Gamma\left(\frac{3}{4}\right) \Gamma\left(\frac{1}{4}\right)}{\Gamma(1)} \\
&= \frac{1}{4} \Gamma\left(1 - \frac{1}{4}\right) \Gamma\left(\frac{1}{4}\right) \\
&= \frac{1}{4} \frac{\pi}{\sin \frac{\pi}{4}} \\
&= \frac{\pi}{2\sqrt{2}}.
\end{aligned}$$

13. Prove that  $\int_0^{\pi/2} \frac{d\theta}{\sqrt{\sin \theta}} \times \int_0^{\pi/2} \sqrt{\sin \theta} d\theta = \pi$ .

**Solution**

$$\begin{aligned} \text{L.H.S. } & \int_0^{\pi/2} \sin^{-\frac{1}{2}} \theta d\theta \times \int_0^{\pi/2} \sin^{\frac{1}{2}} \theta d\theta \\ &= \frac{1}{2} \beta \left[ \frac{-\frac{1}{2}+1}{2}, \frac{0+1}{2} \right] \times \frac{1}{2} \beta \left[ \frac{\frac{1}{2}+1}{2}, \frac{0+1}{2} \right] \\ &= \frac{1}{4} \beta \left[ \frac{1}{4}, \frac{1}{2} \right] \times \beta \left[ \frac{3}{4}, \frac{1}{2} \right] \\ &= \frac{1}{4} \left[ \frac{\Gamma\left(\frac{1}{4}\right) \Gamma\left(\frac{1}{2}\right)}{\Gamma\left(\frac{3}{4}\right)} \right] \left[ \frac{\Gamma\left(\frac{3}{4}\right) \Gamma\left(\frac{1}{2}\right)}{\Gamma\left(\frac{5}{4}\right)} \right] \\ &= \frac{1}{4} \frac{\left\{ \Gamma\left(\frac{1}{2}\right) \right\}^2 \Gamma\left(\frac{1}{4}\right)}{\frac{1}{4} \Gamma\left(\frac{1}{4}\right)} = \pi. \quad \left( \text{since } \Gamma\left(\frac{1}{2}\right) = \sqrt{\pi} \right) \end{aligned}$$

14. Prove that  $\int_0^{\infty} \frac{e^{-x^2}}{\sqrt{x}} dx \times \int_0^{\infty} x^2 e^{-x^4} dx = \frac{\pi}{4\sqrt{2}}$ .

**Solution**

Substituting  $x^2 = t$  or  $x = \sqrt{t}$  in the first integral,

we get

$$\begin{aligned} dx &= \frac{dt}{2\sqrt{t}} \\ I_1 &= \int_0^{\infty} \frac{e^{-t}}{(t^{1/2})^{\frac{1}{2}}} \cdot \frac{1}{2\sqrt{t}} dt \\ &= \frac{1}{2} \int_0^{\infty} t^{-\frac{3}{4}} e^{-t} dt \\ &= \frac{1}{2} \int_0^{\infty} t^{\frac{1}{4}-1} e^{-t} dt \\ &= \frac{1}{2} \Gamma\left(\frac{1}{4}\right) \end{aligned}$$

Taking  $x^4 = u$  or  $x = u^{1/4}$  in the second integral, we obtain,  $dx = \frac{1}{4} u^{-3/4} du$

$$\begin{aligned} I_2 &= \int_0^{\infty} x^2 e^{-x^4} dx \\ &= \int_0^{\infty} (x^{1/4})^2 \cdot e^{-u} \cdot \frac{1}{4} u^{-3/4} du \\ &= \frac{1}{4} \int_0^{\infty} u^{-1/4} e^{-u} du \\ &= \frac{1}{4} \int_0^{\infty} u^{3/4-1} e^{-u} du \\ &= \frac{1}{4} \Gamma\left(\frac{3}{4}\right) \end{aligned}$$

$\therefore$  The given integral  $= I_1 \times I_2$

$$\begin{aligned} &= \frac{1}{8} \Gamma\left(\frac{1}{4}\right) \Gamma\left(\frac{3}{4}\right) \\ &= \frac{1}{8} \Gamma\left(\frac{1}{4}\right) \Gamma\left(1 - \frac{1}{4}\right) \\ &= \frac{1}{8} \cdot \frac{\pi}{\sin \frac{\pi}{4}} = \frac{\pi}{4\sqrt{2}}. \end{aligned}$$

15. Prove that  $\int_0^1 \frac{x^2}{\sqrt{1-x^4}} dx \times \int_0^1 \frac{dx}{\sqrt{1+x^4}} = \frac{\pi}{4\sqrt{2}}$ .

**Solution.** In the first integral setting  $x^2 = \sin \theta$  or  $x = \sqrt{\sin \theta}$  we get  $dx = \frac{\cos \theta}{2\sqrt{\sin \theta}} d\theta$  when

$x = 1, \theta = \frac{\pi}{2}$ , when  $x = 0, \theta = 0$ .

Therefore,

$$\begin{aligned} I_1 &= \int_0^1 \frac{x^2}{\sqrt{1-x^4}} dx = \int_0^{\pi/2} \frac{\sin \theta}{\sqrt{1-\sin^2 \theta}} \cdot \frac{\cos \theta}{2\sqrt{\sin \theta}} d\theta \\ &= \frac{1}{2} \int_0^{\pi/2} \frac{\sin \theta}{\cos \theta} \cdot \frac{\cos \theta}{\sqrt{\sin \theta}} d\theta \\ &= \frac{1}{2} \int_0^{\pi/2} \sin^{1/2} \theta d\theta \end{aligned}$$



$$\begin{aligned}
 &= \frac{1}{2} \cdot \frac{1}{2} \beta \left[ \frac{\frac{1}{2} + 1}{2}, \frac{0 + 1}{2} \right] \\
 &= \frac{1}{4} \beta \left( \frac{3}{4}, \frac{1}{2} \right)
 \end{aligned}$$

In the second integral substitute  $x^2 = \tan \theta$  or  $x = \sqrt{\tan \theta}$  then  $dx = \frac{\sec^2 \theta d\theta}{2\sqrt{\tan \theta}}$ .

when  $x = 0$ ,  $\theta = 0$

when  $x = 1$ ,  $\theta = \pi/4$

Hence,

$$\begin{aligned}
 I_2 &= \int_0^{\pi/4} \frac{1}{\sqrt{1 + \tan^2 \theta}} \cdot \frac{\sec^2 \theta}{2\sqrt{\tan \theta}} \cdot d\theta \\
 &= \frac{1}{2} \int_0^{\pi/4} \frac{\sec \theta}{\sqrt{\tan \theta}} d\theta \\
 &= \frac{1}{2} \int_0^{\pi/4} \frac{d\theta}{\sqrt{\sin \theta \cdot \cos \theta}} \\
 &= \frac{1}{2} \int_0^{\pi/4} \frac{d\theta}{\sqrt{\left(\frac{1}{2}\right) \sin 2\theta}} \\
 &= \frac{1}{\sqrt{2}} \int_0^{\pi/4} \frac{d\theta}{\sqrt{\sin 2\theta}}
 \end{aligned}$$

where

$$t = 2\theta, dt = 2 \cdot d\theta, \Rightarrow d\theta = \frac{1}{2} dt$$

$$\theta = 0, t = 0, \text{ when } \theta = \frac{\pi}{4}, t = \frac{\pi}{2}$$

$$\begin{aligned}
 &= \frac{1}{\sqrt{2}} \int_0^{\pi/2} \frac{1}{2} \cdot \frac{dt}{\sqrt{\sin t}} \\
 &= \frac{1}{2\sqrt{2}} \int_0^{\pi/2} \frac{1}{\sqrt{\sin t}} dt \\
 &= \frac{1}{2\sqrt{2}} \int_0^{\pi/2} (\sin t)^{-1/2} dt
 \end{aligned}$$

$$\begin{aligned}
 &= \frac{1}{2\sqrt{2}} \cdot \frac{1}{2} \beta \left[ \frac{-1}{2} + 1, \frac{0+1}{2} \right] \\
 &= \frac{1}{4\sqrt{2}} \beta \left[ \frac{1}{4}, \frac{1}{2} \right]
 \end{aligned}$$

∴ The given integral is

$$\begin{aligned}
 I_1 \times I_2 &= \frac{1}{16\sqrt{2}} \beta \left[ \frac{3}{4}, \frac{1}{2} \right] \cdot \beta \left[ \frac{1}{4}, \frac{1}{2} \right] \\
 &= \frac{1}{16\sqrt{2}} \frac{\Gamma\left(\frac{3}{4}\right) \cdot \Gamma\left(\frac{1}{2}\right)}{\Gamma\left(\frac{5}{4}\right)} \cdot \frac{\Gamma\left(\frac{1}{4}\right) \cdot \Gamma\left(\frac{1}{2}\right)}{\Gamma\left(\frac{3}{4}\right)} = \frac{\pi}{4\sqrt{2}}.
 \end{aligned}$$

**16. Show that**  $\int_{-1}^1 (1+x)^{p-1} (1-x)^{q-1} dx = 2^{p+q-1} \beta(p, q).$

**Solution**

Substitute:

$$1 + x = 2t, \quad dx = 2dt$$

when

$$x = -1, \quad t = 0, \quad \text{when } x = 1, \quad t = 1$$

Given Integral,

$$\begin{aligned}
 &= \int_0^1 (1+x)^{p-1} (1-x)^{q-1} dx && \text{(where } x = 2t - 1) \\
 &= \int_0^1 (2t)^{p-1} [1 - (2t - 1)]^{q-1} 2 dt \\
 &= 2^{p+q-1} \int_0^1 t^{p-1} (1-t)^{q-1} dt \\
 &= 2^{p+q-1} \beta(p, q).
 \end{aligned}$$

**17. Show that**  $\int_a^b (x-a)^{m-1} (b-x)^{n-1} dx = (b-a)^{m+n-1} \beta(m, n).$

**Solution**

Substitute

$$x - a = (b - a) t$$

so that

$$dx = (b - a) dt$$

when

$$x = a, \quad t = 0 \quad \text{and}$$

when

$$x = b, \quad t = 1$$

$$\therefore \int_a^b (x-a)^{m-1} (b-x)^{n-1} dx = \int_0^1 [(b-a)t]^{m-1} [b-a - (b-a)t]^{n-1} (b-a) dt$$

$$\begin{aligned}
&= (b-a)^{m+n-1} \int_0^1 t^{m-1} (1-t)^{n-1} dt \\
&= (b-a)^{m+n-1} \beta(m, n). \quad \text{Hence proved.}
\end{aligned}$$

18. Prove that  $\int_0^1 \frac{x^{m-1} + x^{n-1}}{(1+x)^{m+n}} dx = \beta(m, n)$ .

**Solution**

From the relation,

$$\begin{aligned}
\beta(m, n) &= \int_0^{\infty} \frac{x^{m-1}}{(1+x)^{m+n}} dx \\
&= \int_0^1 \frac{x^{m-1}}{(1+x)^{m+n}} dx + \int_1^{\infty} \frac{x^{m-1}}{(1+x)^{m+n}} dx \quad \dots(1)
\end{aligned}$$

In the second integral on R.H.S. of (1)

Substitute  $x = 1/t$  so that  $dx = -dt/t^2$

when  $x = 1, t = 1$ , and

when  $x = \infty, t = 0$

$$\begin{aligned}
\text{Hence, } \int_1^{\infty} \frac{x^{m-1}}{(1+x)^{m+n}} dx &= \int_1^0 \frac{\left(\frac{1}{t}\right)^{m-1}}{\left(1+\frac{1}{t}\right)^{m+n}} \left(\frac{-dt}{t^2}\right) \\
&= - \int_1^0 \frac{1}{t^{m-1}} \cdot \frac{t^{m+n}}{(1+t)^{m+n}} \cdot \frac{dt}{t^2} \\
&= \int_0^1 \frac{t^{n-1}}{(1+t)^{m+n}} dt \\
&= \int_0^1 \frac{x^{n-1}}{(1+x)^{m+n}} dx
\end{aligned}$$

Therefore from (1), we get

$$\begin{aligned}
\beta(m, n) &= \int_0^1 \frac{x^{m-1}}{(1+x)^{m+n}} dx + \int_0^1 \frac{x^{n-1}}{(1+x)^{m+n}} dx \\
&= \int_0^1 \frac{x^{m-1} + x^{n-1}}{(1+x)^{m+n}} dx \quad \text{Hence proved.}
\end{aligned}$$

19. Prove that 
$$\int_0^{\pi/2} \frac{\cos^{2m-1}\theta \sin^{2n-1}\theta}{(a \cos^2\theta + b \sin^2\theta)^{m+n}} d\theta = \frac{I}{2a^m b^n} \beta(m, n).$$

**Solution.** Let  $I$  be the given integral,

then 
$$I = \int_0^{\pi/2} \frac{\cos^{2m-1}\theta \sin^{2n-1}\theta}{(\cos^2\theta)^{m+n} (a + b \tan^2\theta)} d\theta$$

$$= \int_0^{\pi/2} \frac{\tan^{2n-1}\theta \sec^2\theta d\theta}{(a + b \tan^2\theta)^{m+n}}$$

Substituting  $\tan \theta = t$ , we get  $\sec^2 \theta d\theta = dt$

when  $\theta = 0, t = 0$  and

when  $\theta = \pi/2, t = \infty$

Then 
$$I = \int_0^{\infty} \frac{t^{2n+1}}{(a + bt^2)^{m+n}} dt$$

Now substitute  $bt^2 = ay$  or  $t = \frac{\sqrt{a}}{\sqrt{b}} \sqrt{y}$

so that 
$$dt = \frac{\sqrt{a}}{\sqrt{b}} \frac{dy}{2\sqrt{y}}$$

Limits remain the same.

Hence, 
$$I = \int_0^{\infty} \frac{(\sqrt{a}\sqrt{y}/\sqrt{b})^{2n+1}}{(a + by)^{m+n}} \cdot \frac{\sqrt{a}}{\sqrt{b}} \frac{dy}{2\sqrt{y}}$$

$$= \frac{1}{2a^m b^m} \int_0^{\infty} \frac{y^{n-1}}{(1+y)^{m+n}} dy$$

$$= \frac{1}{2a^m b^m} \beta(m, n)$$

where  $\beta(m, n) = \int_0^{\infty} \frac{y^{n-1}}{(1+y)^{m+n}} dy$  **Hence proved.**

### EXERCISE 3.3

#### 1. Evaluate

$$(1) \frac{\Gamma(7)}{2\Gamma(4)\Gamma(3)} \quad [\text{Ans. } 30] \qquad (2) \frac{\Gamma(3)\Gamma\left(\frac{3}{2}\right)}{\Gamma\left(\frac{9}{2}\right)} \quad \left[ \text{Ans. } \frac{16}{105} \right]$$

$$(3) \Gamma\left(\frac{1}{2}\right)\Gamma\left(\frac{3}{2}\right)\Gamma\left(\frac{5}{2}\right) \quad \left[ \text{Ans. } \frac{3\pi\sqrt{\pi}}{8} \right] \qquad (4) \frac{\Gamma\left(\frac{7}{3}\right)}{\Gamma\left(\frac{4}{3}\right)} \quad \left[ \text{Ans. } \frac{4}{3} \right]$$

$$(5) \frac{\Gamma(3)\Gamma\left(\frac{5}{2}\right)}{\Gamma\left(\frac{11}{2}\right)} \quad \left[ \text{Ans. } \frac{16}{315} \right]$$

#### 2. Evaluate

$$(1) \Gamma\left(\frac{-5}{2}\right) \quad \left[ \text{Ans. } \frac{-8\sqrt{\pi}}{15} \right] \qquad (2) \Gamma\left(\frac{-7}{2}\right) \quad \left[ \text{Ans. } \frac{16\sqrt{\pi}}{105} \right]$$

$$(3) \Gamma\left(\frac{-9}{2}\right) \quad \left[ \text{Ans. } \frac{-32\sqrt{\pi}}{945} \right] \qquad (4) \Gamma\left(\frac{-1}{3}\right) \cdot \left[ \text{Ans. } -3\Gamma\left(\frac{2}{3}\right) \right]$$

#### 3. Evaluate

$$(1) \int_0^{\infty} x^5 e^{-x} dx \quad [\text{Ans. } 120] \qquad (2) \int_0^{\infty} \sqrt{x} e^{-x} dx \quad \left[ \text{Ans. } \frac{\sqrt{\pi}}{2} \right]$$

$$(3) \int_0^{\infty} x^{3/2} e^{-x} dx \quad \left[ \text{Ans. } \frac{3\sqrt{\pi}}{4} \right] \qquad (4) \int_0^{\infty} x^3 e^{-2x} dx \quad \left[ \text{Ans. } \frac{3}{8} \right]$$

$$(5) \int_0^{\infty} x^6 e^{-2x} dx \quad \left[ \text{Ans. } \frac{45}{8} \right] \qquad (6) \int_0^{\infty} x^5 e^{-x^2} dx \quad \left[ \text{Ans. } \frac{105\sqrt{\pi}}{8} \right]$$

$$(7) \int_0^{\infty} e^{-x^3} dx \quad \left[ \text{Ans. } \frac{1}{3}\Gamma\left(\frac{1}{3}\right) \right] \qquad (8) \int_0^1 (\log x)^3 dx \quad [\text{Ans. } -6]$$

$$(9) \int_0^1 (x \log x)^4 dx \quad \left[ \text{Ans. } \frac{94}{625} \right] \qquad (10) \int_0^1 \left(\log \frac{1}{x}\right)^{3/2} dx \quad \left[ \text{Ans. } -2\sqrt{\pi} \right]$$

$$(11) \int_0^{\infty} 2^{-3x^2} dx \quad \left[ \text{Ans. } \frac{\sqrt{\pi}}{2\sqrt{3 \log 2}} \right] \qquad (12) \int_0^1 x^2 \left(\log \frac{1}{x}\right)^3 dx \quad \left[ \text{Ans. } \frac{2}{27} \right]$$

4. Show that  $\int_0^{\infty} \frac{e^{-st}}{\sqrt{t}} dt = \sqrt{\frac{\pi}{s}}, s > 0.$

5. Prove that  $\Gamma(n) = \int_0^1 \left(\log \frac{1}{x}\right)^{n-1} dx, n > 0.$

6. Prove that  $\Gamma(n) = a^n \int_0^{\infty} e^{-ax} x^{n-1} dx.$

7. Prove that  $\Gamma(n) = 2a^n \int_0^{\infty} x^{2n-1} e^{-ax^2} dx.$

8. Prove that

(1)  $\int_0^{\infty} x^{n-1} \cos ax dx = \frac{1}{a^n} \Gamma(n) \cos\left(\frac{n\pi}{2}\right)$

(2)  $\int_0^{\infty} x^{n-1} \sin ax dx = \frac{1}{a^n} \Gamma(n) \sin\left(\frac{n\pi}{2}\right).$

[Hint. choose  $a = 0, b = a,$  in solved example 8.]

9. Evaluate:

(1)  $\beta(4, 3)$   $\left[ \text{Ans. } \frac{1}{60} \right]$  (2)  $\beta\left(\frac{3}{2}, \frac{5}{2}\right)$   $\left[ \text{Ans. } \frac{\pi}{6} \right]$

(3)  $\beta\left(\frac{7}{2}, \frac{1}{2}\right)$   $\left[ \text{Ans. } \frac{5\pi}{16} \right]$  (4)  $\beta\left(\frac{1}{4}, \frac{1}{2}\right)$   $\left[ \text{Ans. } \left\{ \Gamma\left(\frac{1}{4}\right) \right\}^2 / \sqrt{2} \pi \right]$

(5)  $\beta\left(\frac{5}{6}, \frac{1}{6}\right).$   $[ \text{Ans. } 2\pi ]$

10. Evaluate the following integrals:

(1)  $\int_0^1 x^{3/2} (1-x)^{1/2} dx$   $\left[ \text{Ans. } \frac{\pi}{16} \right]$  (2)  $\int_0^1 \sqrt{\frac{x}{1-x}} dx$   $\left[ \text{Ans. } \frac{\pi}{2} \right]$

(3)  $\int_0^2 \frac{x^2}{\sqrt{2-x}} dx$   $\left[ \text{Ans. } \frac{64\sqrt{2}}{15} \right]$  (4)  $\int_0^4 u^{3/2} (4-u)^{5/2} du$   $[ \text{Ans. } 12\pi ]$

(5)  $\int_0^3 \frac{dx}{\sqrt{3x-x^2}}$   $[ \text{Ans. } \pi ]$  (6)  $\int_0^1 \frac{dx}{\sqrt{1-x^3}}$   $\left[ \text{Ans. } \frac{\sqrt{\pi} \Gamma\left(\frac{1}{3}\right)}{\Gamma\left(\frac{5}{6}\right)} \right]$

$$(7) \int_0^1 x^3 (1 - \sqrt{x}) dx \quad \left[ \text{Ans. } \frac{1}{21} \right] \quad (8) \int_0^a x^4 \sqrt{a^2 - x^2} dx \quad \left[ \text{Ans. } \frac{\pi a^6}{32} \right]$$

$$(9) \int_0^2 x (8 - x^3)^{1/3} dx \quad \left[ \text{Ans. } \frac{16\pi}{9\sqrt{3}} \right] \quad (10) \int_0^1 \sqrt{1 - x^4} dx \quad \left[ \text{Ans. } \frac{\sqrt{\pi} \Gamma\left(\frac{1}{4}\right)}{\Gamma\left(\frac{3}{4}\right)} \right]$$

11. Evaluate each of the following integrals:

$$(1) \int_0^{\pi/2} \sin^5 \theta d\theta \quad \left[ \text{Ans. } \frac{8}{15} \right] \quad (2) \int_0^{\pi/2} \cos^7 \theta d\theta \quad \left[ \text{Ans. } \frac{16}{35} \right]$$

$$(3) \int_0^{\pi/2} \sin^3 \theta \cos^4 \theta d\theta \quad \left[ \text{Ans. } \frac{2}{105} \right] \quad (4) \int_0^{\pi/2} \sin^{1/2} \theta \cos^{7/2} \theta d\theta \quad \left[ \text{Ans. } \frac{5\sqrt{2} \pi}{64} \right]$$

$$(5) \int_0^{\pi/2} \sin^{1/3} \theta \cos^{-1/3} \theta d\theta \quad \left[ \text{Ans. } \frac{\pi}{\sqrt{3}} \right] \quad (6) \int_0^{\pi/2} \frac{d\theta}{\sqrt{\cos \theta}} \quad \left[ \text{Ans. } \frac{1}{2} \frac{\Gamma\left(\frac{1}{4}\right)}{\Gamma\left(\frac{3}{4}\right)} \right]$$

$$(7) \int_0^{\pi/2} \sqrt{\cot \theta} d\theta \quad \left[ \text{Ans. } \frac{\pi}{\sqrt{2}} \right] \quad (8) \int_0^{\pi/2} \frac{\sqrt[3]{\sin^8 \theta}}{\sqrt{\cos \theta}} d\theta \quad \left[ \text{Ans. } \frac{60}{13} \frac{\Gamma\left(\frac{5}{6}\right) \Gamma\left(\frac{1}{4}\right)}{\sqrt{\pi}} \right]$$

$$(9) \int_0^{\pi/2} \tan^p \theta d\theta, \quad 0 < p < 1. \quad \left[ \text{Ans. } \frac{\pi}{2} \sec\left(\frac{p\pi}{2}\right) \right]$$

12. Evaluate each of the following integrals:

$$(1) \int_0^{\infty} \frac{dx}{1 + x^4} \quad \left[ \text{Ans. } \frac{\pi\sqrt{2}}{4} \right] \quad (2) \int_0^{\infty} \frac{dx}{\sqrt{x}(1+x)} \quad \left[ \text{Ans. } \pi \right]$$

$$(3) \int_0^{\infty} \frac{x^2 dx}{(1+x^4)^3} \quad \left[ \text{Ans. } \frac{5\sqrt{2} \pi}{128} \right]$$

13. Evaluate:

$$(1) \int_1^3 \frac{dx}{\sqrt{(x-1)(3-x)}} \quad \left[ \text{Ans. } \pi \right]$$

$$(2) \int_0^7 \sqrt[4]{(7-x)(x-3)} dx \quad \left[ \text{Ans. } \frac{2 \left\{ \Gamma\left(\frac{1}{4}\right) \right\}^2}{3\sqrt{\pi}} \right]$$

**14. Show that**

$$(1) \int_0^{\infty} x e^{-x^2} dx \times \int_0^{\infty} x^2 e^{-x^4} dx = \frac{\pi}{16\sqrt{2}}$$

$$(2) \int_0^{\infty} \sqrt{x} e^{-x^2} dx \times \int_0^{\infty} \frac{e^{-x^2}}{\sqrt{x}} dx = \pi$$

$$(3) \int_0^{\infty} x^2 e^{-x^4} dx \times \int_0^{\infty} e^{-x^4} dx = \frac{\pi}{8\sqrt{2}}$$

$$(4) \int_0^{\infty} \sin^p \theta d\theta \times \int_0^{\infty} \sin^{p+1} \theta d\theta = \frac{\pi}{2(P+1)}.$$

**15. Prove that**  $\int_0^{\infty} \frac{x^{n-1}}{(x+a)^{m+n}} dx = \frac{1}{a^n} \beta(m, n).$

**ADDITIONAL PROBLEMS (From Previous Years VTU Exams.)**

**1. Evaluate**  $\int_0^1 \int_0^{\sqrt{1-y^2}} x^3 y dx dy.$

**Solution.** We have

$$I = \int_{y=0}^1 \int_{x=0}^{\sqrt{1-y^2}} x^3 y dx dy$$

*i.e.,*

$$\begin{aligned} I &= \int_{y=0}^1 y \left[ \frac{x^4}{4} \right]_{x=0}^{\sqrt{1-y^2}} dy \\ &= \frac{1}{4} \int_{y=0}^1 y (1-y^2)^2 dy \\ &= \frac{1}{4} \int_{y=0}^1 y (1-2y^2+y^4) dy \\ &= \frac{1}{4} \int_{y=0}^1 (y-2y^3+y^5) dy \\ &= \frac{1}{4} \left[ \frac{y^2}{2} - \frac{2y^4}{4} + \frac{y^6}{6} \right]_{y=0}^1 \end{aligned}$$



$$= \frac{1}{4} \left[ \frac{1}{2} - \frac{1}{2} + \frac{1}{6} \right]$$

$$I = \frac{1}{24}.$$

2. Change the order of integration and hence evaluate  $\int_0^1 \int_{\sqrt{y}}^1 dx dy$ .

**Solution**

$$\text{Let } I = \int_{y=0}^1 \int_{x=\sqrt{y}}^1 dx dy$$

On changing the order of integration,

$$x = \sqrt{y} \Rightarrow x^2 = y$$

$$I = \int_{x=0}^1 \int_{y=0}^{x^2} dy dx$$

$$= \int_{x=0}^1 [y]_0^{x^2} dx = \int_{x=0}^1 x^2 dx = \left[ \frac{x^3}{3} \right]_0^1 = \frac{1}{3}$$

$$I = \frac{1}{3}.$$

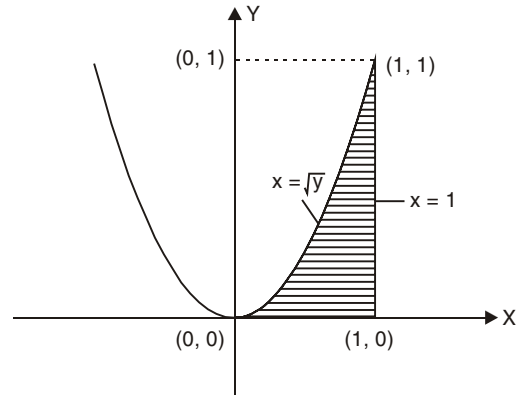

Fig. 3.1

3. Change the order of integration and evaluate  $\int_0^3 \int_0^{\sqrt{4-y}} (x+y) dx dy$ .

**Solution.** Refer page no. 122. Example 5.

4. Change the order of integration and hence evaluate

$$\int_0^{4a} \int_{\frac{x^2}{4a}}^{2\sqrt{ax}} xy dy dx.$$

**Solution.** We have

$$I = \int_{x=0}^{4a} \int_{y=\frac{x^2}{4a}}^{2\sqrt{ax}} xy dy dx$$

$$\text{We have } \frac{x^2}{4a} = 2\sqrt{ax} \quad \text{or} \quad x^4 = 64a^3x$$

$$\text{i.e., } x(x^3 - 64a^3) = 0 \quad \Rightarrow \quad x = 0 \text{ and } x = 4a$$

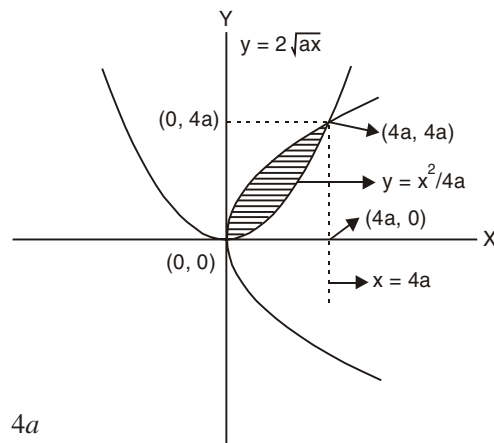

Fig. 3.2

From  $y = \frac{x^2}{4a}$ , we get  $y = 0$  and  $y = 4a$ .

Thus the points of intersection of the parabola  $y = \frac{x^2}{4a}$  and  $y = 2\sqrt{ax}$  are  $(0, 0)$  and  $(4a, 4a)$  on changing the order of integration we have  $y$  varying from 0 to  $4a$  and  $x$  varying from  $\frac{y^2}{4a}$  to  $2\sqrt{ay}$ .

Thus

$$\begin{aligned}
 I &= \int_{y=0}^{4a} \int_{x=\frac{y^2}{4a}}^{2\sqrt{ay}} xy \, dx \, dy \\
 &= \int_{y=0}^{4a} y \cdot \left[ \frac{x^2}{2} \right]_{x=\frac{y^2}{4a}}^{2\sqrt{ay}} dy \\
 &= \frac{1}{2} \int_{y=0}^{4a} y \left[ 4ay - \frac{y^4}{16a^2} \right] dy \\
 &= \frac{1}{2} \int_{y=0}^{4a} \left( 4ay^2 - \frac{y^5}{16a^2} \right) dy \\
 &= \frac{1}{2} \left[ \frac{4ay^3}{3} - \frac{1}{16a^2} \cdot \frac{y^6}{6} \right]_{y=0}^{4a} \\
 &= \frac{1}{2} \left[ 4a \left( \frac{64a^3}{3} \right) - \frac{1}{96a^2} (4096 a^6) \right] \\
 &= \frac{1}{2} \left[ \frac{256a^3}{3} - \frac{128a^4}{3} \right] \\
 &= \frac{64a^4}{3} \\
 I &= \frac{64a^4}{3}.
 \end{aligned}$$

5. Find the value of  $\iint xy(x+y) \, dx \, dy$  taken over the region enclosed by the curves  $y = x$  and  $y = x^2$ .

**Solution.** Refer page no. 118. Example 6.

6. Change the order of integration and hence evaluate  $\int_0^1 \int_x^{\sqrt{2-x^2}} \frac{x}{\sqrt{x^2+y^2}} \, dy \, dx$ .

**Solution.** Refer page no. 120. Example 2.

7. Change the order of integration and hence evaluate  $\int_{y=0}^3 \int_{x=1}^{4-y} (x+y) dx dy$ .

**Solution.** Refer page no. 121. Example 4.

8. With usual notation show that  $\beta(m, n) = \frac{\Gamma(m) \cdot \Gamma(n)}{\Gamma(m+n)}$ .

**Solution.** Refer page no. 133.

9. Show that  $\int_{-1}^1 (1+x)^{p-1} (1-x)^{q-1} dx = 2^{p+q-1} \beta(p, q)$ .

**Solution.** Refer page no. 153. Example 16.

10. Using Beta and Gamma functions evaluate  $\int_0^{\pi/2} \sqrt{\sin \theta} d\theta \times \int_0^{\pi/2} \frac{d\theta}{\sqrt{\sin \theta}}$ .

**Solution.** Refer page no. 150. Example 13.

### OBJECTIVE QUESTIONS

1. The area bounded by the curves  $y^2 = x - 1$  and  $y = x - 3$  is

- (a) 3  
(b)  $\frac{7}{2}$   
(c)  $\frac{9}{2}$   
(d)  $\frac{7}{3}$

[Ans. c]

2. The volume of the tetrahedron bounded by the coordinate planes and the plane

$$\frac{x}{a} + \frac{y}{b} + \frac{z}{c} = 1 \text{ is}$$

- (a)  $\frac{abc}{2}$   
(b)  $\frac{abc}{3}$   
(c)  $\frac{abc}{6}$   
(d)  $\frac{24}{abc}$

[Ans. c]

3. For  $\int_0^{\infty} \int_x^{\infty} f(x, y) dx dy$ , the change of order is

- (a)  $\int_x^{\infty} \int_0^{\infty} f(x, y) dx dy$   
(b)  $\int_0^{\infty} \int_y^{\infty} f(x, y) dx dy$

- (c)  $\int_0^{\infty} \int_0^y f(x, y) dx dy$   
(d)  $\int_0^{\infty} \int_0^x f(x, y) dx dy$

[Ans. c]

4. The value of the integral  $\int_{-2}^2 \frac{dx}{x^2}$  is

(a) 0

(b) 0.25

(c) 1

(d)  $\infty$ .

[Ans. d]

5.  $\int_0^1 \int_{x^2}^{2-x} xy \, dx \, dy$  is equal to

(a)  $\frac{3}{4}$

(b)  $\frac{3}{8}$

(c)  $\frac{3}{5}$

(d)  $\frac{3}{7}$ .

[Ans. b]

6.  $\int_0^2 \int_0^x (x+y) \, dx \, dy = \dots\dots\dots$

(a) 4

(b) 3

(c) 5

(d) None of these.

[Ans. a]

7.  $\int_0^1 \int_0^{1-x} dx \, dy$  represents.....

[Ans. Area of the triangle having vertices (0, 0), (0, 1), (1, 0)]

8.  $\int_0^{\infty} e^{-x^2} dx = \dots\dots\dots$

(a)  $\frac{\sqrt{\pi}}{2}$

(b)  $\frac{\pi}{2}$

(c)  $\frac{\pi}{4}$

(d) None of these.

[Ans. a]

9.  $\beta\left(\frac{1}{2}, \frac{1}{2}\right) = \dots\dots\dots$

(a) 3.1416

(b) 5.678

(c) 2

(d) None of these.

[Ans. a]

10.  $\Gamma(3.5) = \dots\dots\dots$

(a)  $\frac{15}{8}$

(b)  $\frac{15}{8}\sqrt{\pi}$

(c)  $\frac{10}{7}$

(d) None of these.

[Ans. b]

11. The surface area of the sphere  $x^2 + y^2 + z^2 + 2x - 4y + 8z - 2 = 0$  is  
 (a)  $59\pi$  (b)  $60\pi$   
 (c)  $92\pi$  (d) None of these. [Ans. c]
12.  $\int_0^2 \int_1^3 \int_1^2 xy^2z \, dz \, dy \, dx = \dots$   
 (a) 26 (b) 28  
 (c) 30 (d) 50. [Ans. a]
13.  $\iint_R dx \, dy$  is  
 (a) Area of the region  $R$  in the Cartesian form  
 (b) Area of the region  $R$  in the Polar form  
 (c) Volume of a solid  
 (d) None of these. [Ans. a]
14.  $\Gamma\left(\frac{1}{2}\right)$  is  
 (a)  $\sqrt{\pi}$  (b)  $\frac{\sqrt{\pi}}{2}$   
 (c) 2 (d) None of these. [Ans. a]
15.  $\Gamma\left(\frac{-7}{2}\right)$  is  
 (a)  $\frac{16}{15}$  (b)  $\frac{16}{315}$   
 (c)  $\frac{16}{18}$  (d) None of these. [Ans. b]
16.  $\Gamma(n+1)$  is  
 (a)  $n$  (b)  $n+1$   
 (c)  $(n+1)!$  (d)  $n!$ . [Ans. d]
17.  $\beta\left(\frac{7}{2}, \frac{-1}{2}\right)$  is  
 (a)  $\frac{-15\pi}{8}$  (b)  $\frac{15}{8}$   
 (c)  $\frac{\pi}{8}$  (d)  $\frac{15\pi}{8}$ . [Ans. a]

18.  $\int_0^{\infty} x^{\frac{3}{2}} e^{-x} dx$  is

(a)  $\frac{3}{4}$

(c)  $\frac{\sqrt{\pi}}{4}$

(b)  $\frac{3\sqrt{\pi}}{4}$

(d) None of these.

[Ans. b]

19.  $\int_0^{\pi/2} \sin^6 \theta d\theta$  is

(a)  $\frac{5\pi}{32}$

(c)  $\frac{\pi}{32}$

(b)  $\frac{5}{32}$

(d) None of these.

[Ans. a]

20.  $\int_0^{\pi/2} \sin^4 \theta \cos^3 \theta d\theta$  is

(a)  $\frac{5\pi}{32}$

(c)  $\frac{2}{35}$

(b)  $\frac{16}{35}$

(d)  $\frac{6}{35}$ .

[Ans. c]

□□□

## Vector Integration and Orthogonal Curvilinear Coordinates

### 4.1 INTRODUCTION

In the chapter we shall define line integrals, surface integrals and volume integrals which play very important role in Physical and Engineering problems. We shall show that a line integral is a natural generalization of a definite integral and surface integral is a generalization of a double integral.

Line integrals can be transformed into double integrals or into surface integrals and conversely. Triple integrals can be transformed into surface integrals. The corresponding integral theorems of Gauss, Green and Stokes are discussed.

The concept of Gradient, Divergence, Curl and Laplacian already discussed in the known Cartesian system. These will be discussed in a general prospective in the topic orthogonal curvilinear coordinates.

### 4.2 VECTOR INTEGRATION

#### 4.2.1 Vector Line Integral

If  $\vec{F}$  is a force acting on a particle at a point  $P$  whose position vector is  $r$  on a curve  $C$  then  $\int_C \vec{F} \cdot d\vec{r}$  represents physically the total work done in moving the particle along  $C$ .

Thus, total work done is  $\int_C \vec{F} \cdot d\vec{r} = 0$

#### WORKED OUT EXAMPLES

1. If  $\vec{F} = (5xy - 6x^2)\vec{i} + (2y - 4x)\vec{j}$ . Evaluate  $\int_C \vec{F} \cdot d\vec{r}$  along the curve  $y = x^3$  in the  $x$ - $y$  plane from  $(1, 1)$  to  $(2, 8)$ .

**Solution.** We have  $\vec{F} = (5xy - 6x^2)\vec{i} + (2y - 4x)\vec{j}$  and  $\vec{r} = xi + yj$  will give  
 $\frac{d\vec{r}}{dr} = dxi + dyj$

$$\therefore \vec{F} \cdot \vec{dr} = (5xy - 6x^2) dx + (2y - 4x) dy$$

Since  $y = x^3$  we have  $dy = 3x^2 dx$  and varies from 1 to 2

$$\begin{aligned} \int_C \vec{F} \cdot \vec{dr} &= (5x \cdot x^3 - 6x^2) dx + (2 \cdot x^3 - 4x) \cdot 3x^2 dx \\ &= \int_1^2 (5x^4 - 6x^2 + 6x^5 - 12x^3) dx \\ &= [x^5 - 2x^3 + x^6 - 3x^4]_1^2 = 35 \end{aligned}$$

2. If  $\vec{F} = (3x^2 + 6y) \vec{i} - 14yz \vec{j} + 20xz^2 \vec{k}$ . Evaluate  $\int_C \vec{F} \cdot \vec{dr}$  from  $(0, 0, 0)$  to  $(1, 1, 1)$  along

the path  $x = t, y = t^2, z = t^3$ .

**Solution** 
$$\vec{F} = (3x^2 + 6y) \vec{i} - 14yz \vec{j} + 20xz^2 \vec{k}.$$

$$\vec{dr} = dx \vec{i} + dy \vec{j} + dz \vec{k}$$

$$\therefore \vec{F} \cdot \vec{dr} = (3x^2 + 6y) dx - 14yz dy + 20xz^2 dz$$

Since  $x = t, y = t^2, z = t^3$

we obtain

$$dx = dt, dy = 2t dt, dz = 3t^2 dt$$

$$\therefore \vec{F} \cdot \vec{dr} = (3t^2 + 6t^2) dt - (14t^5) 2t dt + (20t^7) 3t^2 dt$$

i.e.,  $\vec{F} \cdot \vec{dr} = (9t^2 - 28t^6 + 60t^9) dt ; 0 \leq t \leq 1$

$\therefore t$  varies from 0 to 1

$$\begin{aligned} \int_C \vec{F} \cdot \vec{dr} &= \int_{t=0}^1 (9t^2 - 28t^6 + 60t^9) dt \\ &= \left[ \frac{9t^3}{3} - \frac{28t^7}{7} + \frac{60t^{10}}{10} \right]_0^1 \\ &= 3 - 4 + 6 \\ &= 5. \end{aligned}$$

3. Evaluate:  $\int_C \vec{F} \cdot \vec{dr}$  where  $\vec{F} = yz \vec{i} + zx \vec{j} + xy \vec{k}$  and  $C$  is given by  $\vec{r} = t \vec{i} + t^2 \vec{j} + t^3 \vec{k}; 0 \leq t \leq 1$ .

**Solution** 
$$\vec{F} = yz \vec{i} + zx \vec{j} + xy \vec{k}$$

$$\vec{r} = t \vec{i} + t^2 \vec{j} + t^3 \vec{k}$$

$$\therefore \vec{dr} = dt \vec{i} + 2t dt \vec{j} + 3t^2 dt \vec{k}$$

$$\therefore \vec{F} \cdot \vec{dr} = yz dt + zx \times 2t dt + xy 3t^2 dt$$

where  $\vec{r} = t \vec{i} + t^2 \vec{j} + t^3 \vec{k} = x \vec{i} + y \vec{j} + z \vec{k}$

$$\therefore x = t, y = t^2, z = t^3$$



$$\begin{aligned}\therefore \vec{F} \cdot \vec{dr} &= t^5 dt + 2t^5 dt + 3t^5 dt \\ &= (t^5 + 2t^5 + 3t^5) dt\end{aligned}$$

$$\therefore \vec{F} \cdot \vec{dr} = 6t^5 dt$$

$\therefore t$  varies from 0 to 1

$$\begin{aligned}\int_C \vec{F} \cdot \vec{dr} &= \int_0^1 6t^5 dt \\ &= \left[ 6 \frac{t^6}{6} \right]_0^1 \\ &= [t^6]_0^1 = 1 - 0 \\ &= 1.\end{aligned}$$

4. Evaluate  $\int_C \vec{F} \cdot \vec{dr}$  where  $\vec{F} = x^2\vec{i} + y^2\vec{j} + z^2\vec{k}$  and  $C$  is given by  $x = \cos t$ ,  $y = \sin t$ ,  $z = t$ ,  $0 \leq t \leq \pi$ .

**Solution**

Here,

$$\vec{F} = x^2\vec{i} + y^2\vec{j} + z^2\vec{k}$$

$$x = \cos t \quad \Rightarrow \quad dx = -\sin t dt$$

$$y = \sin t \quad \Rightarrow \quad dy = \cos t dt$$

$$z = t \quad \Rightarrow \quad dz = dt$$

$$\vec{dr} = dx\vec{i} + dy\vec{j} + dz\vec{k}, \quad 0 \leq t \leq \pi$$

$$\begin{aligned}\int_C \vec{F} \cdot \vec{dr} &= \int_{t=0}^{\pi} (x^2 dx + y^2 dy + z^2 dz) \\ &= \int_0^{\pi} \{-\cos^2 t \sin t dt + \sin^2 t \cos t dt + t^2 dt\} \\ &= \left[ \frac{\cos^3 t}{3} + \frac{\sin^3 t}{3} + \frac{t^3}{3} \right]_0^{\pi} \\ &= -\frac{1}{3} - \frac{1}{3} + 0 + \frac{\pi^2}{3} = \frac{\pi^2 - 2}{3}\end{aligned}$$

5. If  $\vec{F} = x^2\vec{i} + xy\vec{j}$ . Evaluate  $\int_C \vec{F} \cdot \vec{dr}$  from  $(0, 0)$  to  $(1, 1)$  along (i) the line  $y = x$  (ii) the parabola  $y = \sqrt{x}$ .

**Solution**

$$\vec{F} = x^2\vec{i} + xy\vec{j}$$

$$\vec{dr} = dx\vec{i} + dy\vec{j}$$

$$\vec{F} \cdot \vec{dr} = x^2 dx + xy dy$$

(i) Along  $y = x$ ; we have  $0 \leq x \leq 1$  and  $dy = dx$ .

$$\begin{aligned} \therefore \int_C \vec{F} \cdot \vec{dr} &= \int_{x=0}^1 (x^2 + x^2) dx \\ &= \int_{x=0}^1 2x^2 dx = \left[ \frac{2x^3}{3} \right]_0^1 = \frac{2}{3} \end{aligned}$$

(ii) Along  $y = \sqrt{x}$ ,  $y^2 = x \Rightarrow 2y dy = dx$ ,  $0 \leq y \leq 1$

$$\begin{aligned} \int_C \vec{F} \cdot \vec{dr} &= \int_{y=0}^1 (2y^5 + y^3) dy \\ &= \left[ \frac{y^6}{3} + \frac{y^4}{4} \right]_0^1 \\ &= \frac{1}{3} + \frac{1}{4} = \frac{7}{12}. \end{aligned}$$

**6.** Use the line integral, compute work done by a force  $\vec{F} = (2y + 3)\vec{i} + xz\vec{j} + (yz - x)\vec{k}$  when it moves a particle from the point  $(0, 0, 0)$  to the point  $(2, 1, 1)$  along the curve  $x = 2t^2$ ,  $y = t$ ,  $z = t^3$ .

**Solution** Work done =  $\int_C \vec{F} \cdot \vec{dr}$

where,  $\vec{F} = (2y + 3)\vec{i} + xz\vec{j} + (yz - x)\vec{k}$   
 Here,  $x = 2t^2 \Rightarrow dx = 4t dt$   
 $y = t \Rightarrow dy = dt$   
 $z = t^3 \Rightarrow dz = 3t^2 dt$

$t$  varies from 0 to 1 ( $\because y = t$ )

$$\begin{aligned} \vec{dr} &= dx\vec{i} + dy\vec{j} + dz\vec{k} \\ &= 4t dt \vec{i} + dt \vec{j} + 3t^2 dt \vec{k} \\ \int_C \vec{F} \cdot \vec{dr} &= \int_{t=0}^1 \left\{ (2t + 3)4t dt + 2t^5 dt + (t^4 - 2t^2)3t^2 dt \right\} \\ &= \int_0^1 (12t + 8t^2 - 6t^4 + 2t^5 + 3t^6) dt \\ &= \left[ 6t^2 + \frac{8}{3}t^3 - \frac{6}{5}t^5 + \frac{1}{3}t^6 + \frac{3}{7}t^7 \right]_0^1 \\ &= \frac{288}{35}. \end{aligned}$$

7. Find the work done in moving a particle once around an ellipse  $C$  in the  $xy$ -plane, if the ellipse has centre at the origin with semi-major axis 4 and semi-minor axis 3 and if the force field is given by

$$\vec{F} = (3x - 4y + 2z)\vec{i} + (4x + 2y - 3z^2)\vec{j} + (2xz - 4y^2 + z^3)\vec{k}.$$

**Solution.** Here path of integration  $C$  is the ellipse whose equation is  $\frac{x^2}{4^2} + \frac{y^2}{3^2} = 1$  and its parametric equations are  $x = 4 \cos t$ ,  $y = 3 \sin t$ . Also  $t$  varies from 0 to  $2\pi$  since  $C$  is a curve in the  $xy$ -plane, we have  $z = 0$

$$\therefore \vec{F} = (3x - 4y)\vec{i} + (4x + 2y)\vec{j}$$

and

$$\vec{dr} = dx\vec{i} + dy\vec{j}$$

$$\vec{F} \cdot \vec{dr} = [(3x - 4y)\vec{i} + (4x + 2y)\vec{j}] \cdot [dx\vec{i} + dy\vec{j}]$$

$$\vec{F} \cdot \vec{dr} = (3x - 4y) dx + (4x + 2y) dy$$

$$x = 4 \cos t \quad \Rightarrow \quad dx = -4 \sin t dt$$

$$y = 3 \sin t \quad \Rightarrow \quad dy = 3 \cos t dt$$

$\therefore t$  varies from 0 to  $2\pi$

$$\begin{aligned} \int_C \vec{F} \cdot \vec{dr} &= \int_0^{2\pi} \{(12 \cos t - 12 \sin t)(-4 \sin t) dt + (16 \cos t + 6 \sin t) \cdot 3 \cos t dt\} \\ &= \int_0^{2\pi} (48 - 30 \sin t \cos t) dt && \left( \because \sin t \cos t = \frac{\sin 2t}{2} \right) \\ &= \int_0^{2\pi} (48 - 15 \sin 2t) dt \\ &= \left[ 48t + \frac{15}{2} \cos 2t \right]_0^{2\pi} \\ &= 96 \pi. \end{aligned}$$

8. If  $\vec{F} = xy\vec{i} - z\vec{j} + x^2\vec{k}$ . Evaluate  $\int_C \vec{F} \times \vec{dr}$  where  $C$  is the curve  $x = t^2$ ,  $y = 2t$ ,  $z = t^3$  from

$t = 0$  to 1.

**Solution**  $\vec{F} = xy\vec{i} - z\vec{j} + x^2\vec{k}$  and

$$\vec{dr} = dx\vec{i} + dy\vec{j} + dz\vec{k}$$

Hence 
$$\vec{F} \times \vec{dr} = \begin{vmatrix} \vec{i} & \vec{j} & \vec{k} \\ xy & -z & x^2 \\ dx & dy & dz \end{vmatrix}$$

$$\vec{F} \cdot \vec{dr} = -(zdz + x^2dy) \vec{i} - (xy dz - x^2dx) \vec{j} + (xydy + zdx) \vec{k}$$

where

$$\begin{aligned} x = t^2 &\Rightarrow dx = 2tdt \\ y = 2t &\Rightarrow dy = 2dt \\ z = t^3 &\Rightarrow dz = 3t^2dt \end{aligned}$$

$t$  varies from 0 to 1

$$\begin{aligned} &= \left\{ -(3t^5 + 2t^4) \vec{i} - 4t^5 \vec{j} + (4t^3 + 2t^4) \vec{k} \right\} dt \\ \therefore \int_C \vec{F} \cdot \vec{dr} &= -\vec{i} \int_0^1 (3t^5 + 2t^4) dt - 4\vec{j} \int_0^1 t^5 dt + \vec{k} \int_0^1 (4t^3 + 2t^4) dt \\ &= -\vec{i} \left[ \frac{3t^6}{6} + \frac{2t^5}{5} \right]_0^1 - 4\vec{j} \left[ \frac{t^6}{6} \right]_0^1 + \vec{k} \left[ \frac{4t^4}{4} + \frac{2t^5}{5} \right]_0^1 \\ &= \frac{-9}{10} \vec{i} - \frac{2}{3} \vec{j} + \frac{7}{5} \vec{k}. \end{aligned}$$

9. If  $\phi = 2xyz^2$ ,  $\vec{F} = xy\vec{i} - z\vec{j} + x^2\vec{k}$  and  $C$  is the curve:  $x = t^2$ ,  $y = 2t$ ,  $z = t^3$  from  $t = 0$  to

$t = 1$  evaluate the following line integrals. (i)  $\int_C \phi \cdot \vec{dr}$  (ii)  $\int_C \vec{F} \times \vec{dr}$ .

**Solution**

$$\begin{aligned} \vec{dr} &= dx\vec{i} + dy\vec{j} + dz\vec{k} \\ x = t^2 &\Rightarrow dx = 2tdt \\ y = 2t &\Rightarrow dy = 2dt \\ z = t^3 &\Rightarrow dz = 3t^2dt \end{aligned}$$

$$\therefore \vec{dr} = (2t\vec{i} + 2\vec{j} + 3t^2\vec{k}) dt$$

$$\begin{aligned} \phi &= 2xyz^2 \\ \phi &= 2 \cdot t^2 \cdot 2t \cdot t^6 = 4t^9 \end{aligned}$$

$$\therefore \phi \cdot \vec{dr} = (8t^{10} \vec{i} + 8t^9 \vec{j} + 12t^{11} \vec{k}) dt$$

$$\begin{aligned} \text{(i)} \int_C \phi \cdot \vec{dr} &= \int_{t=0}^1 (8t^{10} \vec{i} + 8t^9 \vec{j} + 12t^{11} \vec{k}) dt \\ &= \left[ \frac{8t^{11}}{11} \right]_0^1 \vec{i} + \left[ \frac{8t^{10}}{10} \right]_0^1 \vec{j} + \left[ \frac{12t^{12}}{12} \right]_0^1 \vec{k} \end{aligned}$$

Thus, 
$$\int_C \phi \cdot \vec{dr} = \frac{8}{11} \vec{i} + \frac{4}{5} \vec{j} + \vec{k}$$

$$\text{(ii)} \quad \vec{F} = 2t^3\vec{i} - t^3\vec{j} + t^4\vec{k}$$

$$\vec{F} \times \vec{dr} = \begin{vmatrix} \vec{i} & \vec{j} & \vec{k} \\ 2t^3 & -t^3 & t^4 \\ 2t & 2 & 3t^2 \end{vmatrix}$$

$$\begin{aligned}
&= -(3t^5 + 2t^4) \vec{i} - (6t^5 - 2t^5) \vec{j} + (4t^3 + 2t^4) \vec{k} \\
&= -(3t^5 + 2t^4) \vec{i} - 4t^5 \vec{j} + (4t^3 + 2t^4) \vec{k} \\
\int_C \vec{F} \times \vec{dr} &= \int_0^1 \left\{ (3t^5 + 2t^4) \vec{i} - 4t^5 \vec{j} + (4t^3 + 2t^4) \vec{k} \right\} dt \\
&= - \left[ \frac{t^6}{2} + \frac{2t^5}{5} \right]_0^1 \vec{i} - 4 \left[ \frac{t^6}{6} \right]_0^1 \vec{j} + \left[ t^4 + \frac{2t^5}{5} \right]_0^1 \vec{k} \\
\int_C \vec{F} \times \vec{dr} &= -\frac{9}{10} \vec{i} - \frac{2}{3} \vec{j} + \frac{7}{5} \vec{k}.
\end{aligned}$$

### EXERCISE 4.1

- If  $\vec{F} = 3xy\vec{i} - 5z\vec{j} + 10x\vec{k}$ . Evaluate  $\int_C \vec{F} \cdot \vec{dr}$  along the curve  $C$  given by  $x = t^2 + 1$ ,  $y = 2t^2$ ,  $z = t^3$  from  $t = 1$  to  $t = 2$ . [Ans. 303]
- Evaluate  $\int_C \vec{F} \cdot \vec{dr}$  where  $\vec{F} = (2x + y)\vec{i} + (3y - x)\vec{j} + yz\vec{k}$  and  $C$  is the curve  $x = 2t^2$ ,  $y = t$ ,  $z = t^3$  from  $t = 0$  to  $t = 2$ . [Ans.  $\frac{227}{42}$ ]
- Evaluate  $\int_C \vec{F} \cdot \vec{dr}$  where  $\vec{F} = yz\vec{i} + zx\vec{j} + xy\vec{k}$  and  $C$  is the portion of the curve  $r = acost\vec{i} + bsint\vec{j} + ct\vec{k}$  from  $t = 0$  to  $t = \frac{\pi}{2}$ . [Ans. 0]
- Evaluate  $\int_C \vec{F} \cdot \vec{dr}$  where  $\vec{F} = x^2\vec{i} + y^2\vec{j} + z^2\vec{k}$  and  $C$  is the arc of the curve  $r = ti + t^2j + t^3k$  from  $t = 0$  to  $t = 1$ . [Ans. 1]
- Find the total work done in moving a particle once round a circle  $C$  in the  $xy$ -plane if the curve has centre at the origin and radius 3 and the force field is given by  $\vec{F} = (2x - y + z)\vec{i} + (x + y - z^2)\vec{j} + (3x - 2y + 4z)\vec{k}$ . [Ans.  $8\pi$ ]
- If  $\vec{F} = 2y\vec{i} - z\vec{j} + x\vec{k}$  and  $C$  is the circle  $x = \cos t$ ,  $y = \sin t$ ,  $z = 2 \cos t$  from  $t = 0$  to  $t = \frac{\pi}{2}$  evaluate  $\int_C \vec{F} \times d\vec{k}$ . [Ans.  $\left(2 - \frac{\pi}{4}\right)\vec{i} + \left(\pi - \frac{1}{2}\right)\vec{j}$ ]

### 4.3 INTEGRAL THEOREM

#### 4.3.1 Green's Theorem in a Plane

This theorem gives the relation between the plane, surface and the line integrals.

**Statement.** If  $R$  is a closed region in the  $xy$ -plane bounded by a simple closed curve  $C$  and  $M(x, y)$  and  $N(x, y)$  are continuous functions having the partial derivatives in  $R$  then

$$\int_C M dx + N dy = \iint_R \left( \frac{\partial N}{\partial x} - \frac{\partial M}{\partial y} \right) dx dy.$$

#### 4.3.2 Surface integral and Volume integral

##### Surface Integral

An integral evaluated over a surface is called a surface integral. Consider a surface  $S$  and a point  $P$  on it. Let  $\vec{A}$  be a vector function of  $x, y, z$  defined and continuous over  $S$ .

In  $\hat{n}$  is the unit outward normal to the surface  $S$  and  $P$  then the integral of the normal component of  $\vec{A}$  at  $P$  (i.e.,  $\vec{A} \cdot \hat{n}$ ) over the surface  $S$  is called the surface integral written as

$$\iint_S \vec{A} \cdot \hat{n} ds$$

where  $ds$  is the small element area. To evaluate integral we have to find the double integral over the orthogonal projection of the surface on one of the coordinate planes.

Suppose  $R$  is the orthogonal projection of  $S$  on the  $XOY$  plane and  $\hat{n}$  is the unit outward normal to  $S$  then it should be noted that  $\hat{n} \cdot \hat{k} ds$  ( $\hat{k}$  being the unit vector along  $z$ -axis) is the projection of the vectorial area element  $\hat{n} ds$  on the  $XOY$  plane and this projection is equal to  $dx dy$  which being the area element in the  $XOY$  plane. That is to say that  $\hat{n} \cdot \hat{k} ds = dx dy$ . Similarly, we can argue to state that  $\hat{n} \cdot \hat{j} ds = dz dx$  and  $\hat{n} \cdot \hat{i} ds = dy dz$ . All these three results hold good if we write  $\hat{n} ds = dy dz \hat{i} + dz dx \hat{j} + dx dy \hat{k}$ .

Sometimes we also write

$$d\vec{s} = \hat{n} ds = \sum dy dz \hat{i}$$

##### Volume Integral

If  $V$  is the volume bounded by a surface and if  $F(x, y, z)$  is a single valued function defined over  $V$  then the volume integral of  $F(x, y, z)$  over  $V$  is given by  $\iiint_V F dv$ . If the volume is divided into sub-elements having sides  $dx, dy, dz$  then the volume integral is given by the triple integral  $\iiint F(x, y, z) dx dy dz$  which can be evaluated by choosing appropriate limits for  $x, y, z$ .

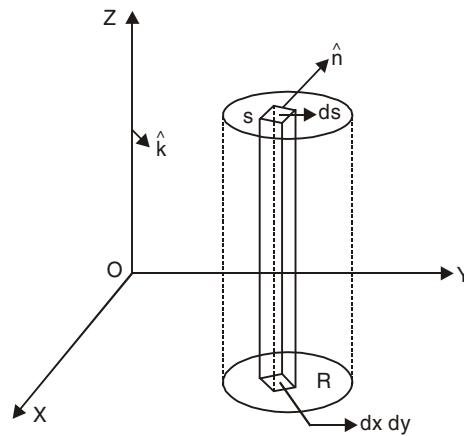

Fig. 4.1

### 4.3.3 Stoke's Theorem

**Statement.** If  $S$  is a surface bounded by a simple closed curve  $C$  and if  $\vec{F}$  is any continuously differentiable vector function then

$$\oint_C \vec{F} \cdot d\vec{r} = \iint_S \text{Curl } \vec{F} \cdot \hat{n} \, ds = \iint_S (\nabla \times \vec{F}) \cdot \hat{n} \, ds$$

### 4.3.4 Gauss Divergence Theorem

**Statement.** If  $V$  is the volume bounded by a surface  $S$  and  $\vec{F}$  is a continuously differentiable vector function then

$$\iiint_V \text{div } \vec{F} \, dV = \iint_S \vec{F} \cdot \hat{n} \, dS$$

where  $\hat{n}$  is the positive unit vector outward drawn normal to  $S$ .

## WORKED OUT EXAMPLES

1. Verify Green's theorem in the plane for  $\int_C [(3x^2 - 8y^2) dx + (4y - 6xy) dy]$  where  $C$  is the

boundary for the region enclosed by the parabola  $y^2 = x$  and  $x^2 = y$ .

**Solution.** We shall find the points of intersection of the parabolas

$$y^2 = x \text{ and } x^2 = y$$

i.e.,  $y = \sqrt{x}$  and  $y = x^2$

Equating both, we get

$$\sqrt{x} = x^2 \Rightarrow x = x^4$$

or  $x - x^4 = 0$

$$x(1 - x^3) = 0$$

$\therefore x = 0, 1$

and hence  $y = 0, 1$  the points of intersection are  $(0, 0)$  and  $(1, 1)$ .

Let  $M = 3x^2 - 8y^2, N = 4y - 6xy$

$$\frac{\partial M}{\partial y} = -16y, \quad \frac{\partial N}{\partial x} = -6y$$

By Green's theorem,

$$\int_C M dx + N dy = \iint_R \left( \frac{\partial N}{\partial x} - \frac{\partial M}{\partial y} \right) dx dy$$

$$\text{L.H.S} = \int_C M dx + N dy$$

$$= \int_{OA} (M dx + N dy) + \int_{AO} (M dx + N dy) = I_1 + I_2$$

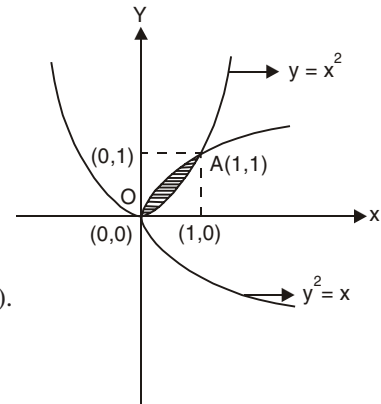

Fig. 4.2

**Along OA:**

$$y = x^2 \quad dy = 2x dx,$$

$x$  varies from 0 to 1

$$\begin{aligned} I_1 &= \int_{x=0}^1 (3x^2 - 8x^4) dx + (4x^2 - 6x^3) 2x dx \\ &= \int_{x=0}^1 (3x^2 + 8x^3 - 20x^4) dx \\ &= \left[ x^3 + 2x^4 - 4x^5 \right]_0^1 = -1 \end{aligned}$$

**Along AO:**

$$y^2 = x \Rightarrow dx = 2y dy,$$

$y$  varies from 1 to 0

$$\begin{aligned} I_2 &= \int_{y=1}^0 (3y^4 - 8y^2) 2y dy + (4y - 6y^3) dy \\ &= \int_1^0 (4y - 22y^3 + 6y^5) dy \\ &= \left[ 2y^2 - \frac{11}{2} y^4 + y^6 \right]_1^0 = \frac{5}{2} \end{aligned}$$

Hence,

$$\text{L.H.S.} = I_1 + I_2 = -1 + \frac{5}{2} = \frac{3}{2}$$

Also

$$\begin{aligned} \text{R.H.S.} &= \iint_R \left( \frac{\partial N}{\partial x} - \frac{\partial M}{\partial y} \right) dx dy \\ &= \int_{x=0}^1 \int_{y=x^2}^{\sqrt{x}} (-6y + 16y) dy dx \\ &= \int_{x=0}^1 \int_{y=x^2}^{\sqrt{x}} 10y dy dx \\ &= \int_{x=0}^1 \left[ \frac{10y^2}{2} \right]_{y=x^2}^{\sqrt{x}} dx \\ &= 5 \int_{x=0}^1 (x - x^4) dx \\ &= 5 \left[ \frac{x^2}{2} - \frac{x^5}{5} \right]_{x=0}^1 \\ &= 5 \left[ \frac{1}{2} - \frac{1}{5} \right] = \frac{3}{2} \end{aligned}$$

$$\therefore \text{L.H.S.} = \text{R.H.S.} = \frac{3}{2}. \quad \text{Hence verified.}$$



2. Verify Green's theorem in the plane for  $\int_C \{(xy + y^2) dx + x^2 dy\}$  where  $C$  is the closed curve of the region bounded by  $y = x$  and  $y = x^2$ .

**Solution.** We shall find the points of intersection of  $y = x$  and  $y = x^2$ .

Equating the R.H.S.

$$\begin{aligned} \therefore x = x^2 &\Rightarrow x - x^2 = 0 \\ &x(1 - x) = 0 \\ &x = 0, 1 \end{aligned}$$

$\therefore y = 0, 1$  and hence  $(0, 0)$ ,  $(1, 1)$  are the points of intersection.

We have Green's theorem in a plane,

$$\int_C M dx + N dy = \iint_R \left( \frac{\partial N}{\partial x} - \frac{\partial M}{\partial y} \right) dx dy$$

The line integral,

$$\begin{aligned} \int_C (xy + y^2) dx + x^2 dy &= \int_{OA} \{(xy + y^2) dx + x^2 dy\} + \int_{AO} \{(xy + y^2) dx + x^2 dy\} \\ &= I_1 + I_2 \end{aligned}$$

Along  $OA$ , we have  $y = x^2$ ,  $\therefore dy = 2x dx$  and  $x$  varies from 0 to 1.

$$\begin{aligned} I_1 &= \int_{x=0}^1 (x \cdot x^2 + x^4) dx + x^2 \cdot 2x dx \\ &= \int_{x=0}^1 (3x^3 + x^4) dx \\ &= \left[ \frac{3x^4}{4} + \frac{x^5}{5} \right]_0^1 = \frac{3}{4} + \frac{1}{5} = \frac{19}{20} \end{aligned}$$

Along  $AO$ , we have  $y = x$   $\therefore dy = dx$

$x$  varies from 1 to 0

$$\begin{aligned} I_2 &= \int_1^0 (x \cdot x + x^2) dx + x^2 dx \\ &= \int_1^0 3x^2 dx = [x^3]_1^0 = -1 \end{aligned}$$

Hence, L.H.S. =  $I_1 + I_2 = \frac{19}{20} - 1 = \frac{-1}{20}$

Also R.H.S. =  $\iint_R \left( \frac{\partial N}{\partial x} - \frac{\partial M}{\partial y} \right) dx dy$

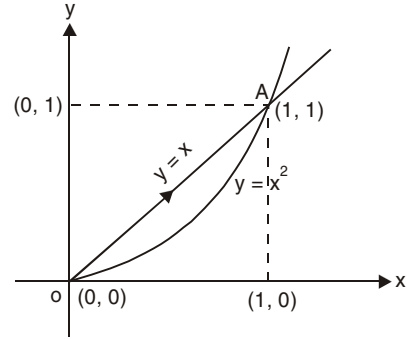

Fig. 4.3

where

$$N = x^2 \qquad M = xy + y^2$$

$$\frac{\partial N}{\partial x} = 2x \qquad \frac{\partial M}{\partial y} = x + 2y$$

$R$  is the region bounded by  $y = x^2$  and  $y = x$

$$\begin{aligned} \iint_R \left( \frac{\partial N}{\partial x} - \frac{\partial M}{\partial y} \right) dx dy &= \int_{x=0}^1 \int_{y=x^2}^x (2x - x - 2y) dy dx \\ &= \int_{x=0}^1 \int_{y=x^2}^x (x - 2y) dy dx \\ &= \int_{x=0}^1 [xy - y^2]_{y=x^2}^x dx \\ &= \int_{x=0}^1 [(x^2 - x^2) - (x^3 - x^4)] dx \\ &= \int_{x=0}^1 (x^4 - x^3) dx \\ &= \left[ \frac{x^5}{5} - \frac{x^4}{4} \right]_0^1 = \frac{1}{5} - \frac{1}{4} = \frac{-1}{20} \end{aligned}$$

$\therefore$  L.H.S. = R.H.S. =  $\frac{-1}{20}$ . Hence verified.

3. Apply Green's theorem in the plane to evaluate  $\int_C [(2x^2 - y^2) dx + (x^2 + y^2) dy]$  where  $C$  is the curve enclosed by the  $x$ -axis and the semicircle  $x^2 + y^2 = 1$ .

**Solution.** The region of integration is bounded by  $AB$  and the semicircle as shown in the figure.

By Green's theorem,

$$\int_C [Mdx + Ndy] = \iint_R \left( \frac{\partial N}{\partial x} - \frac{\partial M}{\partial y} \right) dx dy \quad \dots(1)$$

Given  $\int_C [(2x^2 - y^2) dx + (x^2 + y^2) dy]$

where  $M = 2x^2 - y^2$ ,  $N = x^2 + y^2$

$$\frac{\partial M}{\partial y} = -2y \qquad \frac{\partial N}{\partial x} = 2x$$

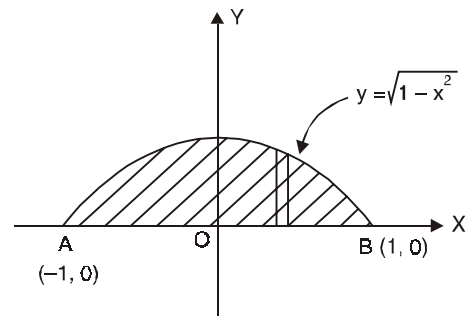

Fig. 4.4

From the equation (1),

$$\int_C [(2x^2 - y^2) dx + (x^2 + y^2) dy] = \iint_R (2x + 2y) dx dy$$

In the region,  $x$  varies from  $-1$  to  $1$  and  $y$  varies from  $0$  to  $\sqrt{1-x^2}$

$$\begin{aligned} &= 2 \int_{x=-1}^1 \int_{y=0}^{\sqrt{1-x^2}} (x+y) dy dx \\ &= 2 \int_{x=-1}^1 \left[ xy + \frac{y^2}{2} \right]_{y=0}^{\sqrt{1-x^2}} dx \\ &= 2 \int_{x=-1}^1 \left[ x\sqrt{1-x^2} + \frac{1}{2}(1-x^2) \right] dx \end{aligned}$$

Since,  $x\sqrt{1-x^2}$  is odd and  $(1-x^2)$  is even function

$$\begin{aligned} &= 0 + 2 \int_0^1 (1-x^2) dx \\ &= 2 \left[ x - \frac{x^3}{3} \right]_0^1 \\ &= \frac{4}{3}. \end{aligned}$$

4. Evaluate  $\int_C (xy - x^2) dx + x^2 y dy$  where  $C$  is the closed curve formed by  $y = 0$ ,  $x = 1$  and  $y = x$  (i) directly as a line integral (ii) by employing Green's theorem.

**Solution**

(i) Let  $M = xy - x^2$ ,  $N = x^2 y$

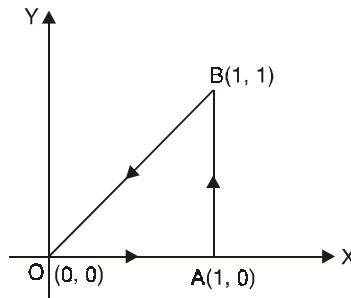

Fig. 4.5

$$\int_C M dx + N dy = \int_{OA} (M dx + N dy) + \int_{AB} (M dx + N dy) + \int_{BO} (M dx + N dy)$$

- (a) Along  $OA$ :  $y = 0 \Rightarrow dy = 0$  and  $x$  varies from 0 to 1.  
 (b) Along  $AB$ :  $x = 1 \Rightarrow dx = 0$  and  $y$  varies from 0 to 1.  
 (c) Along  $BO$ :  $y = x \Rightarrow dy = dx$  and  $x$  varies from 1 to 0.

$$\begin{aligned} \therefore \int_C (M dx + N dy) &= \int_{x=0}^1 -x^2 dx + \int_{y=0}^1 y dy + \int_{x=1}^0 x^3 dx \\ &= -\left[\frac{x^3}{3}\right]_0^1 + \left[\frac{y^2}{2}\right]_0^1 + \left[\frac{x^4}{4}\right]_1^0 \\ &= -\frac{1}{3} + \frac{1}{2} - \frac{1}{4} = \frac{-1}{12} \end{aligned}$$

Thus 
$$\int_C (xy - x^2) dx + x^2 y dy = \frac{-1}{12}$$

(ii) We have Green's theorem,

$$\begin{aligned} \int_C (M dx + N dy) &= \iint_R \left( \frac{\partial N}{\partial x} - \frac{\partial M}{\partial y} \right) dx dy \\ \text{R.H.S.} &= \iint_R (2xy - x) dx dy \\ &= \int_{x=0}^1 \int_{y=0}^x (2xy - x) dy dx \quad (\text{from the figure}) \\ &= \int_{x=0}^1 [xy^2 - xy]_{y=0}^x dx \\ &= \int_{x=0}^1 [x^3 - x^2] dx \\ &= \left[ \frac{x^4}{4} - \frac{x^3}{3} \right]_0^1 \\ &= \frac{1}{4} - \frac{1}{3} = \frac{-1}{12} \end{aligned}$$

$$\therefore \text{R.H.S.} = \frac{-1}{12}.$$

5. Verify Stoke's theorem for the vector  $\vec{F} = (x^2 + y^2) i - 2xyj$  taken round the rectangle bounded by  $x = 0$ ,  $x = a$ ,  $y = 0$ ,  $y = b$ .

**Solution**

By Stoke's theorem : 
$$\int_C \vec{F} \cdot \vec{dr} = \iint_S (\nabla \times \vec{F}) \cdot \vec{n} dS$$



6. Verify Stoke's theorem for the vector field  $\vec{F} = (2x - y)\vec{i} - yz^2\vec{j} - y^2z\vec{k}$  over the upper half surface of  $x^2 + y^2 + z^2 = 1$  bounded by its projection on the  $xy$ -plane.

**Solution** 
$$\int_C \vec{F} \cdot \vec{dr} = \iint_S \text{curl } \vec{F} \cdot \hat{n} dS \quad (\text{Stoke's theorem})$$

$C$  is the circle:  $x^2 + y^2 = 1, z = 0$  ( $xy$ -plane)

i.e.,  $x = \cos t, y = \sin t, z = 0$

$$r = x\vec{i} + y\vec{j} \text{ where } 0 \leq \theta \leq 2\pi$$

$$\vec{dr} = dx\vec{i} + dy\vec{j}$$

where,

$$\vec{F} = (2x - y)\vec{i} - yz^2\vec{j} - y^2z\vec{k}$$

$$\therefore \vec{F} \cdot \vec{dr} = (2x - y) dx \quad (\because z = 0)$$

$$\begin{aligned} \text{L.H.S.} &= \int_C \vec{F} \cdot \vec{dr} = \int_C (2x - y) dx \\ &= \int_0^{2\pi} (2 \cos t - \sin t)(-\sin t) dt \\ &= \int_0^{2\pi} (\sin^2 t - 2 \cos t \sin t) dt \\ &= \int_0^{2\pi} (\sin^2 t - \sin 2t) dt \\ &= \int_0^{2\pi} \left\{ \frac{1}{2}(1 - \cos 2t) - \sin 2t \right\} dt \\ &= \left[ \frac{t}{2} - \frac{\sin 2t}{4} + \frac{\cos 2t}{2} \right]_0^{2\pi} \\ &= \left( \frac{1}{2} - \frac{1}{2} \right) + (\pi - 0) = \pi \end{aligned}$$

Hence, 
$$\vec{F} \cdot \vec{dr} = \pi \quad \dots(1)$$

Also, 
$$\begin{aligned} \text{curl } \vec{F} &= \nabla \times \vec{F} = \begin{vmatrix} \vec{i} & \vec{j} & \vec{k} \\ \frac{\partial}{\partial x} & \frac{\partial}{\partial y} & \frac{\partial}{\partial z} \\ 2x - y & -yz^2 & -y^2z \end{vmatrix} \\ &= \vec{i}(-2yz + 2yz) - \vec{j}(0) + \vec{k}(0 + 1) \end{aligned}$$

$$\begin{aligned}
 &= \vec{k} \\
 \therefore \quad \vec{dS} &= \hat{n}dS \\
 &= dydz \, i + dzdx \, j + dxdy \, k \\
 \text{Hence,} \quad \text{R.H.S.} &= \iint_S \text{curl } \vec{F} \cdot \hat{n}dS = \iint dx \, dy \\
 &= \pi \qquad \dots(2)
 \end{aligned}$$

$\therefore \iint dx \, dy$  represents the area of the circle  $x^2 + y^2 = 1$  which is  $\pi$ .

Thus, from (1) and (2) we conclude that the theorem is verified.

7. If  $\vec{F} = 3y\vec{i} - xz\vec{j} + yz^2\vec{k}$  and  $S$  is the surface of the paraboloid  $2z = x^2 + y^2$  bounded by  $z = 2$ , show by using Stoke's theorem that  $\iint_S \text{curl } \vec{F} \cdot \hat{n} \, ds = 20\pi$ .

**Solution.** If  $z = 0$  then the given surface becomes  $x^2 + y^2 = 4$ .

Hence,  $C$  is the circle  $x^2 + y^2 = 4$  in the plane  $z = 2$

i.e.,  $x = 2 \cos t, y = 2 \sin t, 0 \leq t \leq 2\pi$

Hence by Stoke's theorem, we have

$$\int_C \vec{F} \cdot d\vec{r} = \iint_S \text{curl } \vec{F} \cdot \hat{n} \, dS$$

L.H.S. put  $\vec{F} = 3y\vec{i} - xz\vec{j} + yz^2\vec{k}, d\vec{r} = dx\vec{i} + dy\vec{j} + dz\vec{k}$

$$\therefore \int_C \vec{F} \cdot d\vec{r} = \int_C (3y \, dx - xz \, dy + yz^2 \, dz)$$

where  $z = 2, dz = 0$

$$\therefore \int_C \vec{F} \cdot d\vec{r} = \int_C (3y \, dx - 2x \, dy)$$

$$x = 2 \cos t \quad \Rightarrow \quad dx = -2 \sin t \, dt$$

$$y = 2 \sin t \quad \Rightarrow \quad dy = 2 \cos t \, dt$$

$$\therefore \int_C \vec{F} \cdot d\vec{r} = \int_{2\pi}^0 6 \sin t (-2 \sin t) \, dt - 4 \cos t (2 \cos t) \, dt$$

Since, the surface  $S$  lies below the curve  $C$

$$\begin{aligned}
 &= -\int_{2\pi}^0 (12 \sin^2 t + 8 \cos^2 t) \, dt \\
 &= \int_0^{2\pi} (12 \sin^2 t + 8 \cos^2 t) \, dt
 \end{aligned}$$

$$\begin{aligned}
&= 48 \int_0^{\frac{\pi}{2}} \sin^2 t \, dt + 32 \int_0^{\frac{\pi}{2}} \cos^2 t \, dt \\
&= 48 \cdot \frac{\pi}{4} + 32 \cdot \frac{\pi}{4} = 20\pi \\
\therefore &= \iint_S \operatorname{curl} \vec{F} \cdot \hat{n} \, dS = 20\pi
\end{aligned}$$

Hence proved.

8. Using divergence theorem, evaluate  $\iint_S \vec{F} \cdot \hat{n} \, dS$  where  $\vec{F} = 4xz\vec{i} - y^2\vec{j} + yz\vec{k}$  and  $S$  is the surface of the cube bounded by  $x = 0$ ,  $x = 1$ ,  $y = 0$ ,  $y = 1$ ,  $z = 0$ ,  $z = 1$ .

**Solution.** We have divergence theorem:

$$\iiint_V \operatorname{div} \vec{F} \, dV = \iint_S \vec{F} \cdot \hat{n} \, dS$$

Now

$$\begin{aligned}
\operatorname{div} \vec{F} &= \nabla \cdot \vec{F} \\
&= \left( i \frac{\partial}{\partial x} + j \frac{\partial}{\partial y} + k \frac{\partial}{\partial z} \right) (4xz\vec{i} - y^2\vec{j} + yz\vec{k}) \\
&= \frac{\partial}{\partial x} (4xz) + \frac{\partial}{\partial y} (-y^2) + \frac{\partial}{\partial z} (yz) \\
&= 4z - 2y + y \\
&= 4z - y
\end{aligned}$$

Hence, by divergence theorem, we have

$$\begin{aligned}
\iint_S \vec{F} \cdot \hat{n} \, dS &= \iiint_V \operatorname{div} \vec{F} \cdot dV \\
&= \int_{x=0}^1 \int_{y=0}^1 \int_{z=0}^1 (4z - y) \, dz \, dy \, dx \\
&= \int_{x=0}^1 \int_{y=0}^1 [2z^2 - yz]_{z=0}^1 \, dy \, dx \\
&= \int_{x=0}^1 \int_{y=0}^1 (2 - y) \, dy \, dx \\
&= \int_{x=0}^1 \left[ 2y - \frac{y^2}{2} \right]_0^1 \, dx
\end{aligned}$$



$$\begin{aligned}
&= \int_{x=0}^1 \left[ 2 - \frac{1}{2} \right] dx \\
&= \int_{x=0}^1 \frac{3}{2} dx \\
&= \frac{3}{2} [x]_0^1 = \frac{3}{2}.
\end{aligned}$$

9. Using divergence theorem, evaluate  $\iint_S \vec{F} \cdot \hat{n} dS$  where  $\vec{F} = x^2\vec{i} + y^2\vec{j} + z^2\vec{k}$  and  $S$  is the surface of the solid cut off by the plane  $x + y + z = a$  from the first octant.

**Solution.** Now 
$$\begin{aligned}
\text{div } \vec{F} &= \nabla \cdot \vec{F} = \frac{\partial}{\partial x}(x^2) + \frac{\partial}{\partial y}(y^2) + \frac{\partial}{\partial z}(z^2) \\
&= 2x + 2y + 2z \\
&= 2(x + y + z)
\end{aligned}$$

Hence, by divergence theorem, we have

$$\begin{aligned}
\iint_S \vec{F} \cdot \hat{n} dS &= \iiint_V \text{div } \vec{F} \cdot dV \\
&= \iiint_V 2(x + y + z) dV \\
&= 2 \int_{x=0}^a \int_{y=0}^{a-x} \int_{z=0}^{a-x-y} (x + y + z) dz dy dx \\
&= 2 \int_{x=0}^a \int_{y=0}^{a-x} \left[ (x + y)z + \frac{1}{2}z^2 \right]_{z=0}^{a-x-y} dy dx \\
&= 2 \int_{x=0}^a \int_{y=0}^{a-x} \frac{1}{2} [a^2 - (x + y)^2] dy dx \\
&= \int_{x=0}^a \left[ a^2 y - \frac{(x + y)^3}{3} \right]_{y=0}^{a-x} dx \\
&= \frac{1}{3} \int_{x=0}^a (2a^3 - 3a^2 x + x^3) dx \\
&= \frac{1}{3} \left[ 2a^3 x - 3a^2 \frac{x^2}{2} + \frac{x^4}{4} \right]_0^a \\
\iint_S \vec{F} \cdot \hat{n} \cdot dS &= \frac{1}{4} a^4.
\end{aligned}$$

10. Using divergence theorem, evaluate  $\iint_S \vec{F} \cdot \hat{n} dS$  where  $\vec{F} = x^3i + y^3j + z^3k$  and  $S$  is the surface of the sphere  $x^2 + y^2 + z^2 = a^2$ .

**Solution.**

$$\begin{aligned} \operatorname{div} \vec{F} &= \frac{\partial}{\partial x}(x^3) + \frac{\partial}{\partial y}(y^3) + \frac{\partial}{\partial z}(z^3) \\ &= 3x^2 + 3y^2 + 3z^2 \\ &= 3(x^2 + y^2 + z^2) \end{aligned}$$

∴ by divergence theorem, we get

$$\begin{aligned} \iint_S \vec{F} \cdot \hat{n} dS &= \iiint_V \operatorname{div} \vec{F} dV \\ &= \iiint_V 3(x^2 + y^2 + z^2) dx dy dz \end{aligned} \quad \dots(1)$$

Since,  $V$  is the volume of the sphere we transform the above triple integral into spherical polar coordinates  $(r, \theta, \phi)$ .

For the spherical polar coordinates  $(r, \theta, \phi)$ , we have

$$x^2 + y^2 + z^2 = r^2 \text{ and } dx dy dz = dV$$

$$\therefore dV = r^2 \sin \theta dr d\theta d\phi$$

Also,  $0 \leq r \leq a$ ,  $0 \leq \theta \leq \pi$  and  $0 \leq \phi \leq 2\pi$

Therefore (1) reduces to,

$$\begin{aligned} \iint_S \vec{F} \cdot \hat{n} dS &= 3 \int_{r=0}^a \int_{\theta=0}^{\pi} \int_{\phi=0}^{2\pi} (r^2) r^2 \sin \theta dr d\theta d\phi \\ &= 3 \int_{r=0}^a r^4 dr \times \int_{\theta=0}^{\pi} \sin \theta d\theta \times \int_{\phi=0}^{2\pi} d\phi \\ &= 3 \times \left[ \frac{r^5}{5} \right]_{r=0}^a \times [-\cos \theta]_{\theta=0}^{\pi} \times [\phi]_{\phi=0}^{2\pi} \\ &= \frac{3a^5}{5} \times (-\cos \pi + 1) \times 2\pi \\ &= \frac{12}{5} \pi a^5. \end{aligned}$$

11. Evaluate  $\iint_S (yzi + zxj + xyk) \cdot \hat{n} dS$  where  $S$  is the surface of the sphere  $x^2 + y^2 + z^2 = a^2$  in the first octant.

**Solution.** The given surface is  $x^2 + y^2 + z^2 = a^2$ , we know that  $\nabla\phi$  is a vector normal to the surface  $\phi(x, y, z) = c$ .

Taking  $\phi(x, y, z) = x^2 + y^2 + z^2$

$$\begin{aligned}\nabla\phi &= \frac{\partial\phi}{\partial x}i + \frac{\partial\phi}{\partial y}j + \frac{\partial\phi}{\partial z}k \\ &= 2xi + 2yj + 2zk\end{aligned}$$

$\therefore$  unit vector normal

$$\hat{n} = \frac{\nabla\phi}{|\nabla\phi|}$$

$$\hat{n} = \frac{2(xi + yj + zk)}{\sqrt{2^2(x^2 + y^2 + z^2)}}$$

$$= \frac{xi + yj + zk}{\sqrt{x^2 + y^2 + z^2}}$$

$$= \frac{xi + yj + zk}{a} \quad (\because x^2 + y^2 + z^2 = a^2)$$

Also, if

$$\vec{F} = yzi + zyj + xyk$$

$$\vec{F} \cdot \hat{n} = \frac{1}{a}(xyz + yzx + zxy)$$

$$= \frac{3xyz}{a} \quad \dots(1)$$

Projection the given surface on the  $xy$ -plane, we get  $dx dy = \hat{n} \cdot \hat{k} dS$

$$\therefore dS = \frac{dx dy}{\hat{n} \cdot \hat{k}} = \frac{dx dy}{\frac{z}{a}} = \frac{a dx dy}{z} \quad \dots(2)$$

From (1) and (2)

$$\begin{aligned}\iint_S \vec{F} \cdot \hat{n} \cdot dS &= \iint_R \frac{3xyz}{a} \cdot \frac{a dx dy}{z} \\ &= \iint_R 3xy dx dy\end{aligned}$$

The region  $R$  of integration is the quadrant of the circle  $x^2 + y^2 = a^2$

$$\begin{aligned}\iint_S \vec{F} \cdot \hat{n} \cdot dS &= 3 \int_{x=0}^a \int_{y=0}^{\sqrt{a^2-x^2}} xy dy dx \\ &= 3 \int_{x=0}^a x \left[ \frac{y^2}{2} \right]_{y=0}^{\sqrt{a^2-x^2}} dx\end{aligned}$$

$$\begin{aligned}
&= \frac{3}{2} \int_0^a x(a^2 - x^2) dx \\
&= \frac{3}{2} \left[ \frac{a^2 x^2}{2} - \frac{x^4}{4} \right]_0^a \\
&= \frac{3}{2} \left[ \frac{a^4}{2} - \frac{a^4}{4} \right] \\
&= \frac{3a^4}{8}
\end{aligned}$$

Thus  $\iint_S (yzi + zyj + xyk) \cdot \hat{n} dS = \frac{3a^4}{8}$ .

12. Evaluate  $\iint_S (axi + byj + czk) \cdot \hat{n} dS$  where  $S$  is the surface of the sphere  $x^2 + y^2 + z^2 = 1$ .

**Solution.** Let  $\vec{F} = axi + byj + czk$

we have  $\iint_S \vec{F} \cdot \hat{n} dS = \iiint_V \text{div } \vec{F} \cdot dV$

$$\begin{aligned}
\text{div } \vec{F} = \nabla \cdot \vec{F} &= \left( i \frac{\partial}{\partial x} + j \frac{\partial}{\partial y} + k \frac{\partial}{\partial z} \right) (axi + byj + czk) \\
&= \frac{\partial}{\partial x}(ax) + \frac{\partial}{\partial y}(by) + \frac{\partial}{\partial z}(cz) \\
&= (a + b + c)
\end{aligned}$$

$$\begin{aligned}
\therefore \iint_S \vec{F} \cdot \hat{n} dS &= \iiint_V (a + b + c) dV \\
&= (a + b + c) V \qquad \dots(1)
\end{aligned}$$

where  $V$  is the volume of the sphere with unit radius and  $V = \frac{4}{3}\pi r^3$  for a sphere of radius  $r$ .

Here, since we have  $r = 1$ ,  $V = \frac{4}{3}\pi$

Thus,  $\iint_S \vec{F} \cdot \hat{n} dS = \frac{4\pi}{3}(a + b + c)$ .

### EXERCISE 4.2

1. If  $\vec{F} = axi + byj + czk$  and  $S$  is the surface of the sphere  $x^2 + y^2 + z^2 = 1$  by using divergence theorem. Evaluate  $\iint_S \vec{F} \cdot \hat{n} dS$ . [Ans.  $\frac{4}{3}\pi$ ]
  
2. Evaluate  $\iint_S \vec{F} \cdot \hat{n} dS$  where  $\vec{F} = 4xy\vec{i} + yz\vec{j} - xz\vec{k}$  and  $S$  is the surface of the cube bounded by the planes  $x = 0, x = 2, y = 0, y = 2, z = 0, z = 2$ . [Ans. 32]
  
3. If  $\vec{F} = y^2z^2\vec{i} + z^2x^2\vec{j} + x^2y^2\vec{k}$ , evaluate  $\iint_S \vec{F} \cdot \hat{n} dS$  where  $S$  is the part of the sphere  $x^2 + y^2 + z^2 = 1$  above the  $xy$ -plane and bounded by this plane. [Ans.  $\frac{\pi}{12}$ ]
  
4. Use Gauss divergence theorem to evaluate  $\iint_S \vec{F} \cdot \hat{n} dS$  where  $\vec{F} = (x^2 - z^2)\vec{i} + 2xy\vec{j} + (y^2 + z^2)\vec{k}$  where  $S$  is the surface of the cube bounded by  $x = 0, x = 1, y = 0, y = 1, z = 0, z = 1$ . [Ans. 3]
  
5. Verify Green's theorem in plane for  $\int_C (3x^2 - 8y^2) dx + (4y - 6xy) dy$ , where  $C$  is the boundary of the triangle formed by the lines  $x = 0, y = 0$  and  $x + y = 1$ . [Ans.  $\frac{5}{3}$ ]
  
6. Verify Green's Theorem in the plane for  $\int_C (x^2 + y^2) dx - 2xy dy$ , where  $C$  is the rectangle bounded by the lines  $x = 0, y = 0, x = a, y = b$ . [Ans.  $-2ab^2$ ]
  
7. Using Green's theorem, evaluate  $\int_C (\cos x \sin y - xy) dx + \sin x \cos y dy$ , where  $C$  is the circle  $x^2 + y^2 = 1$ . [Ans. 0]
  
8. Evaluate by Stoke's theorem  $\int_C (yzdx + xzdy + xydz)$ , where  $C$  is the curve  $x^2 + y^2 = 1, z = y^2$ . [Ans. 0]
  
9. Verify Stoke's theorem for the function  $\vec{F} = zi + xj + yk$ , where  $C$  is the unit circle in the  $xy$ -plane bounding the hemisphere  $Z = \sqrt{1 - x^2 - y^2}$ . [Ans.  $\pi$ ]

10. If  $\vec{F} = yi + z^3xj - y^3zk$  and  $C$  is the circle  $x^2 + y^2 = 4$  in the plane  $z = \frac{3}{2}$ . Evaluate  $\int_C \vec{F} \cdot d\vec{r}$  by Stoke's theorem. [Ans.  $\frac{19\pi}{2}$ ]

11. Evaluate  $\int_C \vec{F} \cdot d\vec{r}$  by Stoke's theorem  $\vec{F} = y^2i + x^2j - (x + 2)k$  and  $C$  is the boundary of the triangle with vertices  $(0, 0, 0)$   $(1, 0, 0)$  and  $(1, 1, 0)$ . [Ans.  $\frac{1}{3}$ ]

### 4.4 ORTHOGONAL CURVILINEAR COORDINATES

#### 4.4.1 Definition

Let the coordinates  $(x, y, z)$  of any point be expressed as functions of  $(u_1, u_2, u_3)$ , so that  $x = x(u_1, u_2, u_3)$ ,  $y = y(u_1, u_2, u_3)$ ,  $z = z(u_1, u_2, u_3)$  then  $u, v, w$  can be expressed in terms of  $x, y, z$ , as  $u_1 = u(x, y, z)$ ,  $u_2 = v(x, y, z)$  and  $u_3 = w(x, y, z)$ . And also if  $\frac{\partial(x, y, z)}{\partial(u_1, u_2, u_3)} \neq 0$  then the

system of coordinates  $(u_1, u_2, u_3)$  will be an alternative specification of the Cartesian system  $(x, y, z)$  and  $(u_1, u_2, u_3)$  are called the curvilinear coordinates of the point.

If one of the coordinates is kept constant say  $u_1 = c$ , then

and the locus of  $(x, y, z)$  is a surface which is called a coordinate surface. Thus, we have three families of coordinate system corresponding to  $u_1 = c, u_2 = c, u_3 = c$ .

Suppose  $u_1 = c, u_2 = c$  and  $u_3 \neq c$  in that case locus obtained is called a coordinate curve and also there are such families.

The tangent to the coordinate curves at the point  $p$  and the three coordinate axes of the curvilinear systems.

The direction of these axes vary from point to point and hence the unit associated with them are not constant.

When the coordinate surfaces are mutually perpendicular to each other, the three curves define an orthogonal system and  $(u, v, w) = (u_1, u_2, u_3)$  are called orthogonal curvilinear coordinates.

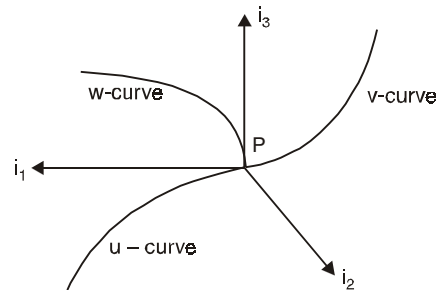

Fig. 4.7

#### 4.4.2 Unit Tangent and Unit Normal Vectors

The position vector of point  $p(x, y, z)$  is  $\vec{r} = xi_1 + yi_2 + zi_3$  where  $i_1, i_2, i_3$  are unit vectors along the tangent to the three coordinate curves.

$$\therefore i_1 \cdot i_2 = i_3 \cdot i_2 = i_3 \cdot i_1 = 0$$

and  $i_1 \times i_2 = i_3, i_2 \times i_3 = i_1, i_3 \times i_1 = i_2$

$$\therefore \vec{r}(u_1, u_2, u_3) = x(u_1, u_2, u_3) i_1 + y(u_1, u_2, u_3) i_2 + z(u_1, u_2, u_3) i_3$$

$$\therefore \quad \vec{dr} = \frac{\vec{\partial r}}{\partial u_1} du_1 + \frac{\vec{\partial r}}{\partial u_2} du_2 + \frac{\vec{\partial r}}{\partial u_3} du_3$$

Then  $\vec{r}(u_1, u_2, u_3)$  is a vector point, function of variables  $u, v, w$ .

The unit tangent vector  $i_1$  along the tangent to  $u$ -curve at  $P$  is

$$i_1 = \frac{\frac{\vec{\partial r}}{\partial u_1}}{\left| \frac{\vec{\partial r}}{\partial u_1} \right|}$$

If  $\left| \frac{\vec{\partial r}}{\partial u_1} \right| = h_1$  which is called scalar factor, then  $\frac{\partial r}{\partial u_1} = h_1 i_1$ .

Similarly, unit tangent vectors along  $v$ -curve and  $w$ -curves are

$$i_2 = \frac{\frac{\vec{\partial r}}{\partial u_2}}{\left| \frac{\vec{\partial r}}{\partial u_2} \right|} = \frac{\vec{\partial r}}{h_2}$$

$$\therefore \quad \frac{\vec{\partial r}}{\partial u_2} = h_2 i_2$$

$$i_3 = \frac{\frac{\vec{\partial r}}{\partial u_3}}{\left| \frac{\vec{\partial r}}{\partial u_3} \right|} = \frac{\vec{\partial r}}{h_3}$$

$$\therefore \quad \frac{\vec{\partial r}}{\partial u_3} = h_3 i_3$$

$$\begin{aligned} \therefore \quad \vec{dr} &= \frac{\vec{\partial r}}{\partial u_1} du_1 + \frac{\vec{\partial r}}{\partial u_2} du_2 + \frac{\vec{\partial r}}{\partial u_3} du_3 \\ &= h_1 du_1 i_1 + h_2 du_2 i_2 + h_3 du_3 i_3 \end{aligned}$$

Then length of the arc  $dS$  is given by

$$dS^2 = \vec{dr} \cdot \vec{dr} = h_1^2 du_1^2 + h_2^2 du_2^2 + h_3^2 du_3^2$$

**Example 1.** Find the square of the element of arc length in cylindrical coordinates and determine the corresponding Lommel constants.

**Solution.** The position vector,  $\vec{r}$  in cylindrical coordinates is

$$\vec{r} = r \cos \theta \vec{i} + r \sin \theta \vec{j} + z \vec{k}$$

Then

$$\begin{aligned} dr &= \frac{\partial \vec{r}}{\partial r} dr + \frac{\partial \vec{r}}{\partial \theta} d\theta + \frac{\partial \vec{r}}{\partial z} dz \\ &= \left( \cos\theta \vec{i} + \sin\theta \vec{j} \right) dr + \left( -r \sin\theta \vec{i} + r \cos\theta \vec{j} \right) d\theta + \vec{k} dz \\ &= (\cos\theta dr - r \sin\theta d\theta) \vec{i} + (\sin\theta dr + r \cos\theta d\theta) \vec{j} + \vec{k} dz \end{aligned}$$

From the relation,

$$dS^2 = \vec{dr} \cdot \vec{dr} = h_1^2 du_1^2 + h_2^2 du_2^2 + h_3^2 du_3^2$$

we have,

$$\begin{aligned} dS^2 &= \vec{dr} \cdot \vec{dr} = (\cos\theta dr - r \sin\theta d\theta)^2 + (\sin\theta dr + r \cos\theta d\theta)^2 + dz^2 \\ &= (dr)^2 + r^2(d\theta)^2 + dz^2 \end{aligned}$$

The Lommel's constant, also called scale factors are  $h_1 = 1$ ,  $h_2 = r$ ,  $h_3 = 1$ .

**Example 2.** Find the volume element  $dv$  in cylindrical coordinates.

**Solution.** The volume element in orthogonal curvilinear coordinates  $u_1, u_2, u_3$  is given by

$$u_1 = r, \quad u_2 = \theta, \quad u_3 = z,$$

In cylindrical coordinates  $h_1 = 1, \quad h_2 = r, \quad h_3 = 1.$

Then  $dv = h_1 h_2 h_3 du_1 du_2 du_3$

$$u_1 = r \quad \Rightarrow \quad du_1 = dr,$$

$$u_2 = \theta \quad \Rightarrow \quad du_2 = d\theta,$$

$$u_3 = z \quad \Rightarrow \quad du_3 = dz,$$

$$\therefore \quad dv = (1) \cdot (r) \cdot (1) \cdot dr d\theta dz$$

Then,  $dv = r dr d\theta dz.$

#### 4.4.3 The Differential Operators

In this section, we shall express the gradient, divergence and curl in terms of orthogonal curvilinear coordinates  $u_1, u_2, u_3$ . Then, the Laplacian can be expressed as the divergence of a gradient by the chain rule, we have

$$\frac{\partial f}{\partial x} = \frac{\partial f}{\partial u_1} \frac{\partial u_1}{\partial x} + \frac{\partial f}{\partial u_2} \frac{\partial u_2}{\partial x} + \frac{\partial f}{\partial u_3} \frac{\partial u_3}{\partial x}$$

$$\frac{\partial f}{\partial y} = \frac{\partial f}{\partial u_1} \frac{\partial u_1}{\partial y} + \frac{\partial f}{\partial u_2} \frac{\partial u_2}{\partial y} + \frac{\partial f}{\partial u_3} \frac{\partial u_3}{\partial y}$$

$$\frac{\partial f}{\partial z} = \frac{\partial f}{\partial u_1} \frac{\partial u_1}{\partial z} + \frac{\partial f}{\partial u_2} \frac{\partial u_2}{\partial z} + \frac{\partial f}{\partial u_3} \frac{\partial u_3}{\partial z}$$

In rectangular Cartesian coordinate system

$$\nabla f = \frac{\partial f}{\partial x} \vec{i} + \frac{\partial f}{\partial y} \vec{j} + \frac{\partial f}{\partial z} \vec{k}$$

where  $f$  is a scalar function. In engineering problems this  $f$  is usually a potential link



Velocity potential or electric potential or gravitational potential.

Using chain rule this becomes,

$$\begin{aligned}\nabla f &= \frac{\partial f}{\partial u_1} \left[ \frac{\partial u_1}{\partial x} i + \frac{\partial u_1}{\partial y} j + \frac{\partial u_1}{\partial z} k \right] \\ &+ \frac{\partial f}{\partial u_2} \left[ \frac{\partial u_2}{\partial x} i + \frac{\partial u_2}{\partial y} j + \frac{\partial u_2}{\partial z} k \right] \\ &+ \frac{\partial f}{\partial u_3} \left[ \frac{\partial u_3}{\partial x} i + \frac{\partial u_3}{\partial y} j + \frac{\partial u_3}{\partial z} k \right] \\ &= \frac{\partial f}{\partial u_1} \nabla u_1 + \frac{\partial f}{\partial u_2} \nabla u_2 + \frac{\partial f}{\partial u_3} \nabla u_3\end{aligned}$$

But  $\nabla u_1 = \frac{1}{h_1} \hat{e}_1, \nabla u_2 = \frac{1}{h_2} \hat{e}_2, \nabla u_3 = \frac{1}{h_3} \hat{e}_3.$

Then the gradient of  $f$ , in orthogonal curvilinear coordinates, is

$$\nabla f = \frac{1}{h_1} \frac{\partial f}{\partial u_1} e_1 + \frac{1}{h_2} \frac{\partial f}{\partial u_2} e_2 + \frac{1}{h_3} \frac{\partial f}{\partial u_3} e_3.$$

### WORKED OUT EXAMPLES

1. Show that  $\left[ \frac{\vec{\partial r}}{\partial u_1}, \frac{\vec{\partial r}}{\partial u_2}, \frac{\vec{\partial r}}{\partial u_3} \right] = h_1 h_2 h_3 = \frac{1}{[\nabla u_1, \nabla u_2, \nabla u_3]}.$

**Solution.** By definition of unit vectors,

$$\hat{e}_1 = \frac{1}{h_1} \frac{\partial r}{\partial u_1}, \hat{e}_2 = \frac{1}{h_2} \frac{\partial r}{\partial u_2}, \hat{e}_3 = \frac{1}{h_3} \frac{\partial r}{\partial u_3} \quad \dots(1)$$

we also know that

$$\nabla u_1 = \frac{1}{h_1} \hat{e}_1, \nabla u_2 = \frac{1}{h_2} \hat{e}_2, \nabla u_3 = \frac{1}{h_3} \hat{e}_3 \quad \dots(2)$$

Then using (1), we have

$$\begin{aligned}\left[ \frac{\vec{\partial r}}{\partial u_1}, \frac{\vec{\partial r}}{\partial u_2}, \frac{\vec{\partial r}}{\partial u_3} \right] &= [h_1 \hat{e}_1, h_2 \hat{e}_2, h_3 \hat{e}_3] \\ &= [h_1 h_2 h_3] [\hat{e}_1 \hat{e}_2 \hat{e}_3] \\ &= h_1 h_2 h_3 \quad \dots(3)\end{aligned}$$

Similarly from (2), we have

$$\begin{aligned} [\nabla u_1, \nabla u_2, \nabla u_3] &= \left[ \frac{1}{h_1} \hat{e}_1, \frac{1}{h_2} \hat{e}_2, \frac{1}{h_3} \hat{e}_3 \right] \\ &= \frac{1}{h_1 h_2 h_3} [\hat{e}_1, \hat{e}_2, \hat{e}_3] = \frac{1}{h_1 h_2 h_3} \end{aligned} \quad \dots(4)$$

From (3) and (4), we obtain

$$\left[ \frac{\partial r}{\partial u_1}, \frac{\partial r}{\partial u_2}, \frac{\partial r}{\partial u_3} \right] = h_1 h_2 h_3 = \frac{1}{[\nabla u_1, \nabla u_2, \nabla u_3]}$$

as the required solution.

2. Find the  $\nabla r^m$ .

**Solution.** The position vector of a point  $(x, y, z)$  from  $\frac{m}{2}$ , the origin is

$$\begin{aligned} \vec{r} &= xi + yj + zk \\ r &= \sqrt{x^2 + y^2 + z^2} \end{aligned}$$

Then

$$\nabla r^m = mr^m \cdot \left( \frac{\vec{r}}{r^2} \right) = mr^{m-2}$$

$$\vec{r} = mr^{m-2} (xi + yj + zk).$$

3. Find the gradient of  $f = x^2y + zy^2 + xz^2$  in curvilinear coordinates.

**Solution.** In curvilinear coordinates  $(u_1, u_2, u_3)$  the given function  $f$  takes the form

$$\begin{aligned} f &= u_1^2 u_2 + u_3 u_2^2 + u_1 u_3^2 \\ \frac{\partial f}{\partial u_1} &= 2u_1 u_2 + u_3^2, \quad \frac{\partial f}{\partial u_2} = 2u_3 u_2 + u_1^2 \\ \frac{\partial f}{\partial u_3} &= u_2^2 + 2u_1 u_3 \end{aligned}$$

The gradient formula is

$$\nabla f = \frac{1}{h_1} \frac{\partial f}{\partial u_1} \hat{e}_1 + \frac{1}{h_2} \frac{\partial f}{\partial u_2} \hat{e}_2 + \frac{1}{h_3} \frac{\partial f}{\partial u_3} \hat{e}_3$$

Sub.  $\frac{\partial f}{\partial u_1}$ ,  $\frac{\partial f}{\partial u_2}$  and  $\frac{\partial f}{\partial u_3}$ , we get

$$\nabla f = \frac{1}{h_1} (2u_1 u_2 + u_3^2) \hat{e}_1 + \frac{1}{h_2} (u_1^2 + 2u_3 u_2) \hat{e}_2 + \frac{1}{h_3} (u_2^2 + 2u_1 u_3) \hat{e}_3$$

which is the required gradient.



Using (1) and  $\vec{A} \cdot (\vec{A} \times \vec{B}) = 0$  for any pair of vectors, we have

$$\begin{aligned} \nabla \cdot \vec{F} &= \frac{\partial}{\partial u_1} (h_2 h_3 F_1) \nabla u_1 \cdot (\nabla u_2 \times \nabla u_3) \\ &\quad + \frac{\partial}{\partial u_2} (h_3 h_1 F_2) \nabla u_2 \cdot (\nabla u_3 \times \nabla u_1) \\ &\quad + \frac{\partial}{\partial u_3} (h_1 h_2 F_3) \nabla u_3 \cdot (\nabla u_1 \times \nabla u_2). \end{aligned}$$

But  $\hat{e}_1 \cdot (\hat{e}_2 \times \hat{e}_3) = \hat{e}_2 \cdot (\hat{e}_3 \times \hat{e}_1) = \hat{e}_3 \cdot (\hat{e}_1 \times \hat{e}_2)$   
 $= h_1 h_2 h_3 \nabla u_1 \cdot (\nabla u_2 \times \nabla u_3) = h_1 h_2 h_3 \nabla u_2 \cdot (\nabla u_3 \times \nabla u_1)$   
 $= h_1 h_2 h_3 \nabla u_3 \cdot (\nabla u_1 \times \nabla u_2) = 1$

$\therefore \nabla \cdot \vec{F} = \frac{1}{h_1 h_2 h_3} \left[ \frac{\partial}{\partial u_1} (h_2 h_3 F_1) + \frac{\partial}{\partial u_2} (h_3 h_1 F_2) + \frac{\partial}{\partial u_3} (h_1 h_2 F_3) \right]$

**WORKED OUT EXAMPLES**

1. If  $f$  and  $g$  are continuously differentiable show that  $\nabla f \times \nabla g$  is a solenoidal.

**Solution.** A vector  $\vec{F}$  is solenoidal if  $\nabla \cdot \vec{F} = 0$ . To show that  $\nabla f \times \nabla g$  is solenoidal. First we show that  $\nabla f \times \nabla g$  can be expressed as a curl of a vector. We can show this using the identity.

$$\begin{aligned} \nabla \times (f \nabla g) &= \nabla f \times \nabla g + f \nabla \times \nabla g \\ &= \nabla f \times \nabla g \end{aligned} \quad (\because \text{curl grad is zero})$$

Operating divergence on this and using the identity

$$\nabla \times \nabla (f \nabla g) = 0 \quad (\because \text{div curl of any vector is zero})$$

This gives  $\nabla \cdot (\nabla f \times \nabla g) = 0$

Hence,  $\nabla f \times \nabla g$  is solenoidal and hence proved.

2. Find  $\nabla \cdot (\nabla r^m)$

**Solution.** Let  $\vec{r} = xi + yj + zk$  be the position vector so that  $r = (x^2 + y^2 + z^2)^{\frac{1}{2}}$

This gives  $\nabla r^m = m r^{m-2} \vec{r}$

$\therefore \nabla \cdot \nabla r^m = \frac{\partial}{\partial x} (m r^{m-2} x) + \frac{\partial}{\partial y} (m r^{m-2} y) + \frac{\partial}{\partial z} (m r^{m-2} z)$  ... (1)

Differentiating by part, we get

$$\frac{\partial}{\partial x} (m r^{m-2} x) = m(m-2) r^{m-2} \cdot \frac{\partial r}{\partial x} x + m r^{m-2}$$

But  $\frac{\partial r}{\partial x} = \frac{1}{2} (x^2 + y^2 + z^2)^{-\frac{1}{2}} 2x$

$$= x(x^2 + y^2 + z^2)^{-\frac{1}{2}}$$

$$= \frac{x}{r}$$

Similarly,  $\frac{\partial}{\partial x}(mr^{m-2} \cdot x) = m(m-2)r^{m-4}x^2 + mr^{m-2}$

$$\frac{\partial}{\partial y}(mr^{m-2}y) = m(m-2)r^{m-4}y^2 + mr^{m-2}$$

$$\frac{\partial}{\partial z}(mr^{m-2}z) = m(m-2)r^{m-4}z^2 + mr^{m-2}$$

Equation (1) becomes, then

$$\nabla \cdot (\nabla r^m) = m(m-2)r^{m-4}r^2 + 3mr^{m-2}$$

$$= m(m+1)r^{m-2}.$$

### EXERCISE 4.4

1. Show that

$$(i) \nabla \cdot \vec{r} = 3$$

$$(ii) \nabla \cdot (\vec{r} \times \vec{a}) = 0$$

$$(iii) \nabla \cdot (\vec{a} \times \vec{r}) = 0$$

$$(iv) \nabla \cdot (\vec{x} \times \vec{y}) = \vec{y} \cdot \nabla \vec{x} - \vec{x} \cdot \nabla \times \vec{y}$$

2. Prove that

$$(i) \nabla \cdot \nabla f = \frac{\partial^2 f}{\partial x^2} + \frac{\partial^2 f}{\partial y^2} + \frac{\partial^2 f}{\partial z^2}$$

$$(ii) \nabla \cdot \nabla \times \vec{F} = 0$$

#### 4.4.5 Curl of a Vector

Let 
$$\vec{F} = F_1\hat{e}_1 + F_2\hat{e}_2 + F_3\hat{e}_3$$

$$= h_1F_1\nabla u_1 + h_2F_2\nabla u_2 + h_3F_3\nabla u_3$$

Then, 
$$\nabla \times \vec{F} = \nabla \times (h_1F_1\nabla u_1) + \nabla \times (h_2F_2\nabla u_2) + \nabla \times (h_3F_3\nabla u_3)$$

$$= \nabla(h_1F_1) \times \nabla u_1 + h_1F_1\nabla \times \nabla u_1 + \nabla(h_2F_2) \times \nabla u_2 + h_2F_2\nabla \times \nabla u_2 + \nabla(h_3F_3) \times \nabla u_3 + h_3F_3\nabla \times \nabla u_3$$

But curl of a gradient is zero

$$\nabla \times \vec{F} = \nabla(h_1F_1) \times \nabla u_1 + \nabla(h_2F_2) \times \nabla u_2 + \nabla(h_3F_3) \times \nabla u_3 \quad \dots(1)$$

But 
$$\nabla(h_1F_1) \times \nabla u_1 = \left[ \frac{\partial}{\partial u_1}(h_1F_1) \cdot \frac{\hat{e}_1}{h_1} + \frac{\partial}{\partial u_2}(h_2F_2) \frac{\hat{e}_2}{h_2} + \frac{\partial}{\partial u_3}(h_3F_3) \frac{\hat{e}_3}{h_3} \right] \cdot \frac{\hat{e}_1}{h_1}$$

Using the fact that  $\hat{e}_1, \hat{e}_2$  and  $\hat{e}_3$  are the orthogonal unit vectors, we have

$$\nabla(h_1 F_1) \times \nabla u_1 = \frac{1}{h_1 h_3} \frac{\partial}{\partial u_3} (h_1 F_1) \hat{e}_2 - \frac{1}{h_1 h_2} \frac{\partial}{\partial u_2} (h_1 F_1) \hat{e}_3$$

Similarly, we can show that

$$\nabla(h_2 F_2) \times \nabla u_2 = \frac{1}{h_1 h_2} \frac{\partial}{\partial u_1} (h_2 F_2) \cdot \hat{e}_3 - \frac{1}{h_2 h_3} \frac{\partial}{\partial u_1} (h_2 F_2) \cdot \hat{e}_1$$

and 
$$\nabla(h_3 F_3) \times \nabla u_3 = \frac{1}{h_2 h_3} \frac{\partial}{\partial u_2} (h_3 F_3) \cdot \hat{e}_3 - \frac{1}{h_1 h_3} \frac{\partial}{\partial u_2} (h_3 F_3) \cdot \hat{e}_2$$

Then the equation (1) becomes

$$\begin{aligned} \nabla \times \vec{F} &= \frac{1}{h_1 h_3} \left[ \frac{\partial}{\partial u_2} (h_3 F_3) - \frac{\partial}{\partial u_3} (h_2 F_2) \right] \hat{e}_1 + \frac{1}{h_1 h_3} \left[ \frac{\partial}{\partial u_3} (h_1 F_1) - \frac{\partial}{\partial u_1} (h_1 F_1) \right] \\ &\quad + \frac{1}{h_1 h_2} \left[ \frac{\partial}{\partial u_1} (h_2 F_2) - \frac{\partial}{\partial u_2} (h_1 F_1) \right] \hat{e}_3 \\ &= \frac{1}{h_1 h_2 h_3} \begin{vmatrix} h_1 \hat{e}_1 & h_2 \hat{e}_2 & h_3 \hat{e}_3 \\ \frac{\partial}{\partial u_1} & \frac{\partial}{\partial u_2} & \frac{\partial}{\partial u_3} \\ h_1 F_1 & h_2 F_2 & h_3 F_3 \end{vmatrix} \end{aligned}$$

### WORKED OUT EXAMPLES

1. Show that  $\nabla \times (f \vec{F}) = \nabla Q \times \vec{F} + f \nabla \times \vec{F}$ .

**Solution.** By definition

$$\begin{aligned} \nabla \times (f \vec{F}) &= \sum \hat{i} \times \frac{\partial}{\partial x} (f \vec{F}) \\ &= \sum \hat{i} \times \left[ \frac{\partial}{\partial x} (f \vec{F}) + f \frac{\partial \vec{F}}{\partial x} \right] \\ &= \sum \hat{i} \times \frac{\partial f \vec{F}}{\partial x} + \sum \hat{i} \times f \frac{\partial \vec{F}}{\partial x} \\ &= \sum \hat{i} \frac{\partial f}{\partial x} \times \vec{F} + \left[ \sum \hat{i} \times \frac{\partial \vec{F}}{\partial x} \right] f \\ &= \nabla f \times \vec{F} + f \nabla \times \vec{F}. \end{aligned}$$

2. Show that  $\nabla \times (\vec{A} \times \vec{B}) = \vec{A} \nabla \cdot \vec{B} - \vec{B} \nabla \cdot \vec{A} + \vec{B} \cdot \nabla \vec{A} - \vec{A} \cdot \nabla \vec{B}$ .

**Solution.** By definition

$$\begin{aligned} \nabla \times (\vec{A} \times \vec{B}) &= \sum \hat{i} \times A \times \frac{\partial \vec{B}}{\partial x} + \frac{\partial \vec{A}}{\partial x} \times \vec{B} \\ &= \sum \left[ \hat{i} \cdot \frac{\partial \vec{B}}{\partial x} \right] \vec{A} - \sum (\hat{i} \cdot \vec{A}) \cdot \frac{\partial \vec{B}}{\partial x} + \sum (\hat{i} \cdot \vec{B}) \frac{\partial \vec{A}}{\partial x} \\ &\quad - \left( \sum \hat{i} \frac{\partial \vec{A}}{\partial x} \right) \cdot \vec{B} - \sum \hat{i} \cdot \left( \frac{\partial \vec{B}}{\partial x} \right) \\ &\quad - \sum \hat{i} \cdot \left( \frac{\partial \vec{A}}{\partial x} \right) \vec{B} + \sum (\hat{i} \cdot \vec{B}) \frac{\partial \vec{A}}{\partial x} - \sum (\hat{i} \cdot \vec{A}) \frac{\partial \vec{B}}{\partial x} \\ &= \vec{A} \nabla \cdot \vec{B} - \vec{B} \nabla \cdot \vec{A} + \vec{B} \cdot \nabla \vec{A} - \vec{A} \cdot \nabla \vec{B} \end{aligned}$$

3. Show that  $\nabla \times \nabla r^m = 0$ .

**Solution.** We know that

$$\nabla r^m = m r^{m-2} (x \hat{i} + y \hat{j} + z \hat{k}). \text{ Then}$$

$$\nabla \times \nabla r^m = \begin{vmatrix} \hat{i} & \hat{j} & \hat{k} \\ \frac{\partial}{\partial x} & \frac{\partial}{\partial y} & \frac{\partial}{\partial z} \\ m r^{m-2} x & m r^{m-2} y & m r^{m-2} z \end{vmatrix}$$

The coefficient of  $\hat{i}$  in this determinant

$$\begin{aligned} &= \frac{\partial}{\partial y} (m r^{m-2} z) - \frac{\partial}{\partial z} (m r^{m-2} y) \\ &= m(m-2) r^{m-3} \frac{yz}{r} - m(m-2) r^{m-3} \frac{zy}{r} = 0 \end{aligned}$$

Hence,  $\nabla \times \nabla r^m = 0$ .

## EXERCISE 4.5

1. If  $\vec{F} = (x + y + 1)\hat{i} + \hat{j} - (x + y)\hat{k}$  then show that  $\vec{F} \cdot \nabla \times \vec{F} = 0$ .
2. If  $\vec{F} = \nabla (x^3 + y^3 + z^3 - 3xyz)$ , then find  $\nabla \times \vec{F}$ .
3. Show that  $\nabla \times \vec{r} = 0$  and  $\nabla \times (\vec{r} \times \vec{a}) = -2\vec{a}$  when  $\vec{r}$  is the position vector and  $\vec{a}$  is constant vector.
4. Show that  $\nabla \times (\vec{r} \times \vec{a}) \times \vec{b} = 2\vec{b} \times \vec{a}$ .

#### 4.4.6. Expression for Laplacian $\nabla^2 \psi$

We now consider the expression for the Laplacian  $\nabla^2 \psi$ . We know that

$$\nabla^2 \psi = \nabla \cdot (\nabla \psi)$$

This, using the expression for gradient and divergence, becomes,

$$\nabla^2 \psi = \frac{1}{h_1 h_2 h_3} \left[ \frac{\partial}{\partial u_1} \left( \frac{h_2 h_3}{h_1} \frac{\partial \psi}{\partial u_1} \right) + \frac{\partial}{\partial u_2} \left( \frac{h_3 h_1}{h_2} \frac{\partial \psi}{\partial u_2} \right) + \frac{\partial}{\partial u_3} \left( \frac{h_1 h_2}{h_3} \frac{\partial \psi}{\partial u_3} \right) \right] \quad \dots(1)$$

#### 4.4.7. Particular Coordinate System

In many practical applications we need differential operator in a particular coordinate system. Some of them will be discussed in this section.

##### (1) Cartesian Coordinates

The Cartesian coordinate system form a particular case of the orthogonal curvilinear coordinates  $(u_1, u_2, u_3)$  in which  $u_1 = x, u_2 = y, u_3 = z$  such that

$$\frac{\partial \vec{r}}{\partial u_1} = \frac{\partial}{\partial x} (x\hat{i} + y\hat{j} + z\hat{k}) = \hat{i}$$

Similarly,  $\frac{\partial \vec{r}}{\partial u_2} = \frac{\partial r}{\partial y} = \hat{j}$  and

$$\frac{\partial \vec{r}}{\partial u_3} = \frac{\partial r}{\partial z} = \hat{k}$$

Then, for Cartesian coordinates system

$$h_1 = \left| \frac{\partial \vec{r}}{\partial u_1} \right| = |\hat{i}| = 1,$$

$$h_2 = \left| \frac{\partial \vec{r}}{\partial u_2} \right| = |\hat{j}| = 1,$$

and  $h_3 = \left| \frac{\partial \vec{r}}{\partial u_3} \right| = 1$

So that, the unit tangent (or base) vectors, becomes

$$\hat{e}_1 = \hat{i}$$

$$\hat{e}_2 = \hat{j}$$

and  $\hat{e}_3 = \hat{k}$

Note that  $\hat{e}_1 \cdot \hat{e}_2 = \hat{i} \cdot \hat{j} = 0$  and so on

and  $\hat{e}_1 \times \hat{e}_2 = \hat{i} \times \hat{j} = \hat{k} = \hat{e}_3$  and so on.

Hence the Cartesian coordinate system is a right hand orthogonal coordinate system.

Then the arc length in this system is

$$dr^2 = dx^2 + dy^2 + dz^2$$



and the volume element is

$$dr = dx dy dz$$

The area element in the  $yz$ -plane perpendicular to the  $x$ -axis is  $dy dz$ , in the  $zx$  perpendicular to the  $y$ -axis is  $dz dx$  and in the  $xy$ -plane perpendicular to  $z$ -axis is  $dx dy$ .

## (2) Cylindrical Polar Coordinates

Let  $(r, \theta, z)$  be the cylindrical coordinates of the point  $p$ . The three surfaces through  $p$  :  $r = u_1 = \text{constant} = c_1$ ;  $\theta = u_2 = \text{constant} = c_2$  and  $z = u_3 = \text{constant} = c_3$  are respectively, the cylinder through  $p$  coaxial with  $oz$ , half plane through  $oz$  making an angle  $\theta$  with the coordinate plane  $xoz$ ; and the planes perpendicular to  $oz$  and distance  $z$  from it.

The coordinates  $(r, \theta, z)$  are related to the Cartesian coordinates  $(x, y, z)$  through the relation  $x = r \cos \theta$ ,  $y = r \sin \theta$ ,  $z = z$ .

The coordinate surface for any set of constants  $C_1$ ,  $C_2$  and  $C_3$  are orthogonal. Therefore, the cylindrical system is orthogonal.

Here,

$$\begin{aligned} u_1 &= r \\ u_2 &= \theta \\ u_3 &= z \text{ and} \end{aligned}$$

position vector  $\vec{r}$  in this is

$$\vec{r} = r \cos \theta \hat{i} + r \sin \theta \hat{j} + z \hat{k}$$

Hence,

$$\begin{aligned} \frac{\partial \vec{r}}{\partial u_1} &= \frac{\partial \vec{r}}{\partial r} = \frac{\partial}{\partial r} (r \cos \theta \hat{i} + r \sin \theta \hat{j} + z \hat{k}) \\ &= \cos \theta \hat{i} + \sin \theta \hat{j} \end{aligned}$$

$$\frac{\partial \vec{r}}{\partial u_2} = \frac{\partial \vec{r}}{\partial \theta} = -r \sin \theta \hat{i} + r \cos \theta \hat{j}$$

$$\frac{\partial \vec{r}}{\partial u_3} = \frac{\partial \vec{r}}{\partial z} = \hat{k}$$

Then the Lommel constants in this case

$$h_1 = \left| \frac{\partial \vec{r}}{\partial u_1} \right| = \left| \frac{\partial \vec{r}}{\partial r} \right| = (\cos^2 \theta + \sin^2 \theta)^{1/2} = 1$$

$$h_2 = \left| \frac{\partial \vec{r}}{\partial u_2} \right| = \left| \frac{\partial \vec{r}}{\partial \theta} \right| = (r^2 \sin^2 \theta + r^2 \cos^2 \theta)^{1/2} = r$$

$$h_3 = \left| \frac{\partial \vec{r}}{\partial u_3} \right| = \left| \frac{\partial \vec{r}}{\partial z} \right| = 1$$

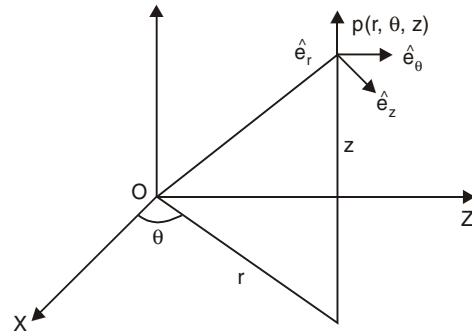

Fig. 4.8

In this case the unit vector  $\hat{e}_r$ ,  $\hat{e}_\theta$  and  $\hat{e}_z$  in the increasing direction of  $(r, \theta, z)$  are respectively take the form:

$$\hat{e}_r = \frac{1}{h_1} \frac{\partial \vec{r}}{\partial u_1} = \frac{\partial \vec{r}}{\partial r} = \cos \theta \hat{i} + \sin \theta \hat{j}$$

$$\hat{e}_\theta = \frac{1}{h_2} \frac{\partial \vec{r}}{\partial u_2} = \frac{1}{r} \frac{\partial \vec{r}}{\partial \theta} = -\sin \theta \hat{i} + \cos \theta \hat{j}$$

$$\hat{e}_z = \frac{1}{h_3} \frac{\partial \vec{r}}{\partial u_3} = \frac{\partial \vec{r}}{\partial z} = \hat{k}$$

From these, it follows that

$$\begin{aligned} \hat{e}_r \cdot \hat{e}_\theta &= \hat{e}_\theta \cdot \hat{e}_z = \hat{e}_z \cdot \hat{e}_r = 0 \\ \hat{e}_r \times \hat{e}_\theta &= (\cos \theta \hat{i} + \sin \theta \hat{j}) \times (-\sin \theta \hat{i} + \cos \theta \hat{j}) \\ &= (\cos^2 \theta + \sin^2 \theta) \hat{k} = \hat{k} = \hat{e}_z \\ \hat{e}_r \times \hat{e}_z &= (\sin \theta \hat{j} + \cos \theta \hat{i}) = \hat{e}_\theta \\ \hat{e}_z \times \hat{e}_r &= (\cos \theta \hat{j} - \sin \theta \hat{i}) = \hat{e}_\theta \end{aligned}$$

The element of arc  $dl$  in cylindrical coordinates will be

$$dl^2 = dr^2 + r^2 d\theta^2 + dz^2.$$

The conditions for  $\hat{e}_r$ ,  $\hat{e}_\theta$ , and  $\hat{e}_z$  show that the cylindrical polar coordinates system is a right handed orthogonal coordinate system.

The differential operators in this coordinate system take the form

$$\begin{aligned} \nabla Q &= \frac{\partial Q}{\partial r} \hat{e}_r + \frac{1}{r} \frac{\partial Q}{\partial \theta} \hat{e}_\theta + \frac{\partial Q}{\partial z} \hat{e}_z \\ \nabla \cdot \vec{F} &= \frac{1}{r} \frac{\partial}{\partial r} (rF_r) + \frac{1}{r} \frac{\partial F_\theta}{\partial \theta} + \frac{\partial F_z}{\partial z} \\ \nabla \times \vec{F} &= \left( \frac{1}{r} \frac{\partial F_z}{\partial \theta} - \frac{\partial F_\theta}{\partial z} \right) \hat{e}_r + \left( \frac{\partial F_r}{\partial z} - \frac{\partial F_r}{\partial \theta} \right) \hat{e}_\theta + \\ &\quad \left( \frac{1}{r} \frac{\partial}{\partial r} (rF_\theta) - \frac{1}{r} \frac{\partial F_r}{\partial \theta} \right) \hat{e}_\theta \end{aligned}$$

Area elements on the coordinate surfaces and the volume elements in this coordinate systems are

$$\begin{aligned} dS_r &= r d\theta dz, \quad dS_\theta = dz dr \\ dS_z &= r dr d\theta, \quad dr = r dr d\theta dz. \end{aligned}$$

### (iii) Spherical Polar Coordinates

If  $(r, \theta, \phi)$  are the spherical polar coordinates, then in this system

$$\begin{aligned} x &= r \sin \theta \cos \phi \\ y &= r \sin \theta \sin \phi \\ z &= r \cos \theta \end{aligned}$$

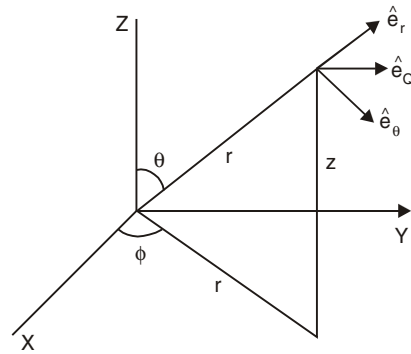

Fig. 4.9

with  $0 \leq r$ ,  $0 \leq \theta \leq \pi$  and  $0 \leq \phi \leq 2\pi$ .

$$\begin{aligned} \text{Here,} \quad u_1 &= r \\ u_2 &= \theta \\ u_3 &= \phi \text{ and} \end{aligned}$$

$$\vec{r} = r \sin \theta \cos \phi \hat{i} + r \sin \theta \sin \phi \hat{j} + r \cos \theta \hat{k}$$

$$\begin{aligned} \text{Then} \quad \frac{\partial r}{\partial u_1} &= \frac{\partial \vec{r}}{\partial r} = \sin \theta \cos \phi \hat{i} + \sin \theta \sin \phi \hat{j} + \cos \theta \hat{k} \\ \frac{\partial r}{\partial u_2} &= \frac{\partial \vec{r}}{\partial \theta} = r \sin \theta \cos \phi \hat{i} + r \cos \theta \sin \phi \hat{j} - \sin \theta \hat{k} \\ \frac{\partial r}{\partial u_3} &= \frac{\partial \vec{r}}{\partial \phi} = -r \sin \theta \sin \phi \hat{i} + r \sin \theta \cos \phi \hat{j} \end{aligned}$$

In this case the formed constants are

$$\begin{aligned} h_1 &= \left| \frac{\partial \vec{r}}{\partial u_1} \right| = \left| \frac{\partial \vec{r}}{\partial r} \right| = [\sin^2 \theta (\cos^2 \phi + \sin^2 \phi) + \cos^2 \theta]^{1/2} = 1 \\ h_2 &= \left| \frac{\partial \vec{r}}{\partial u_2} \right| = \left| \frac{\partial \vec{r}}{\partial \theta} \right| = r [\cos^2 \theta (\cos^2 \phi + \sin^2 \phi) + \sin^2 \theta]^{1/2} = r \\ h_3 &= \left| \frac{\partial \vec{r}}{\partial u_3} \right| = \left| \frac{\partial \vec{r}}{\partial \phi} \right| = r \sin \theta (\cos^2 \phi + \sin^2 \phi)^{1/2} = r \sin \theta \end{aligned}$$

Then the unit vectors are

$$\begin{aligned} \hat{e}_r &= \frac{1}{h_1} \frac{\partial \vec{r}}{\partial u_1} = \frac{\partial \vec{r}}{\partial r} = \sin \theta \cos \phi \hat{i} + \sin \theta \sin \phi \hat{j} + \cos \theta \hat{k} \\ \hat{e}_\theta &= \frac{1}{h_2} \frac{\partial \vec{r}}{\partial u_2} = \frac{1}{r} \frac{\partial \vec{r}}{\partial \theta} = \cos \theta \cos \phi \hat{i} + \cos \theta \sin \phi \hat{j} - \sin \theta \hat{k} \\ \hat{e}_\phi &= \frac{1}{h_3} \frac{\partial \vec{r}}{\partial u_3} = \frac{1}{r \sin \theta} \frac{\partial \vec{r}}{\partial \phi} = -\sin \phi \hat{i} + \cos \phi \hat{j} \end{aligned}$$

From these, we have

$$\begin{aligned} \hat{e}_r \cdot \hat{e}_\theta &= \sin \theta \cos \theta (\cos^2 \phi + \sin^2 \phi) - \cos \theta \sin \theta = 0 \\ \hat{e}_\theta \cdot \hat{e}_\phi &= \cos \theta (-\sin \phi \cos \phi + \sin \phi \cos \phi) = 0 \\ \hat{e}_\phi \cdot \hat{e}_r &= \sin \theta (-\sin \phi \cos \phi + \cos \phi \sin \phi) = 0. \end{aligned}$$

Also

$$\begin{aligned} \hat{e}_r \times \hat{e}_\theta &= \cos \theta (\sin^2 \theta + \cos^2 \theta) \hat{j} - \sin \phi (\sin^2 \theta + \cos^2 \theta) \hat{i} \\ &= \hat{e}_\phi \\ \hat{e}_\theta \times \hat{e}_\phi &= \cos \theta (\cos^2 \phi + \sin^2 \phi) \hat{k} + \sin \theta \sin \phi \hat{j} + \sin \theta \cos \phi \hat{i} = \hat{e}_r \\ \hat{e}_\phi \times \hat{e}_r &= -\sin \theta (\sin^2 \phi + \cos^2 \phi) \hat{k} + \sin \phi \cos \theta \hat{j} + \cos \theta \cos \phi \hat{i} = \hat{e}_\theta. \end{aligned}$$

These conditions show that the spherical polar coordinates system is a right handed orthogonal system.

The element of arc length  $dl$  is

$$dl^2 = dr^2 + r^2 d\theta^2 + r^2 \sin^2 \theta d\phi^2$$

The differential operators are given by

$$\nabla \psi = \frac{\partial \psi}{\partial r} \hat{e}_r + \frac{1}{r} \frac{\partial \psi}{\partial \theta} \hat{e}_\theta + \frac{1}{r \sin \theta} \frac{\partial \psi}{\partial \phi} \hat{e}_\phi$$

$$\nabla \cdot \vec{F} = \frac{1}{r^2} \frac{\partial}{\partial r} (r^2 F_r) + \frac{1}{r \sin \theta} \frac{\partial}{\partial \theta} (\sin \theta F_\theta) + \frac{1}{r \sin \theta} \frac{\partial F_\phi}{\partial \phi}$$

$$\nabla^2 \psi = \frac{\partial^2 \psi}{\partial r^2} + \frac{2}{r} \frac{\partial \psi}{\partial r} + \frac{1}{r^2 \sin \theta} \frac{\partial}{\partial \theta} (\sin \theta \frac{\partial \psi}{\partial \theta}) + \frac{1}{r^2 \sin^2 \theta} \frac{\partial^2 \psi}{\partial \phi^2}$$

$$\nabla \times \vec{F} = \frac{1}{r \sin \theta} \left[ \frac{\partial}{\partial \theta} (\sin \theta F_\phi) - \frac{\partial F_\theta}{\partial \phi} \right] \hat{e}_r +$$

$$\frac{1}{r} \left[ \frac{1}{\sin \theta} \frac{\partial F_r}{\partial \phi} - \frac{\partial}{\partial r} (r F_\phi) \right] \hat{e}_\theta +$$

$$\frac{1}{r} \left[ \frac{\partial}{\partial r} (r F_\theta) - \frac{\partial F_\theta}{\partial \theta} \right] \hat{e}_\phi$$

## WORKED OUT EXAMPLES

1. Verify the equations

(i)  $\nabla \theta + \nabla \times (R \log r) = 0$

(ii)  $\nabla \log r + \nabla \times R\theta = 0$

for cylindrical coordinates.

**Solution.** (i) In cylindrical coordinates

$$\nabla r = \hat{e}_1$$

$$\nabla \theta = \frac{1}{r} \hat{e}_r$$

Then  $\nabla \times (R \log r) = (\nabla \log r) \times R$

$$= \frac{1}{r} \nabla r \times R$$

$$= \frac{1}{r} \hat{e}_1 \times k$$

$$= \frac{-1}{r} \hat{e}_2 = -\nabla\theta$$

$$\therefore \nabla \times R \log r + \nabla\theta = 0$$

Hence the result.

(ii) By definition,

$$\nabla \log r = \frac{1}{r} \nabla r = \left(\frac{1}{r}\right) \hat{e}_1$$

$$\text{Similarly, } \nabla \times (R \theta) = \nabla \theta \times R$$

$$= \frac{1}{r} \hat{e}_2 \times R$$

$$= \frac{-1}{r} \hat{e}_1 = -\nabla \log r$$

$$\therefore \nabla \log r + \nabla \times k\theta = 0$$

Hence proved.

**Example 2.** Determine the scale factors for spherical coordinates. Also find the arc and volume elements.

**Solution.** For spherical coordinates

$$x = r \sin \theta \cos \phi$$

$$y = r \sin \theta \sin \phi$$

$$z = r \cos \theta$$

$$\text{Hence, } dx = dr \sin \theta \cos \phi + d\theta r \cos \theta \cos \phi - d\phi r \sin \theta \sin \phi \quad \dots(1)$$

$$dy = dr \sin \theta \sin \phi + d\theta r \cos \theta \sin \phi + d\phi r \sin \theta \cos \phi \quad \dots(2)$$

$$\text{and } dz = dr \cos \theta - d\theta r \sin \theta \quad \dots(3)$$

Squaring and adding (1), (2) and (3), we have

$$dx^2 + dy^2 + dz^2 = ds^2 = dr^2 + r^2 d\theta^2 + r^2 \sin^2 \theta d\phi^2$$

$$\text{Hence, } h_1^2 = 1, \Rightarrow h_1 = 1, h_2 = r, h_3 = r \sin \theta$$

$$\text{or } h_r = 1, h_\theta = r, h_\phi = r \sin \theta$$

The arc element

$$ds = \sqrt{dr^2 + r^2 d\theta^2 + r^2 \sin^2 \theta d\phi^2}$$

Similarly the volume element

$$\begin{aligned} dV &= h_1 h_2 h_3 du_1 du_2 du_3 \\ &= r^2 \sin \theta dr d\theta dz. \end{aligned}$$

**Example 3.** Prove that the spherical coordinate system is orthogonal.

**Solution.** If  $\bar{R}$  be the position vector of a point  $P(x, y, z)$ , then

$$\bar{R} = x\bar{i} + y\bar{j} + z\bar{k}$$

Substituting the values of  $x, y, z$  we have

$$\begin{aligned}\bar{R} &= r \sin \theta \cos \phi \bar{i} + r \sin \theta \sin \phi \bar{j} + r \cos \theta \bar{k} \\ \therefore \frac{\partial \bar{R}}{\partial r} &= \sin \theta \cos \phi \bar{i} + \sin \theta \sin \phi \bar{j} + \cos \theta \bar{k} \\ \therefore \bar{e}_1 &= \bar{e}_r \\ &= \frac{\frac{\partial \bar{R}}{\partial r}}{\left| \frac{\partial \bar{R}}{\partial r} \right|} = \sin \theta \cos \phi \bar{i} + \sin \theta \sin \phi \bar{j} + \cos \theta \bar{k} \quad \dots(1)\end{aligned}$$

Similarly,

$$\begin{aligned}\bar{e}_2 &= \bar{e}_\theta \\ &= \frac{\frac{\partial \bar{R}}{\partial \theta}}{\left| \frac{\partial \bar{R}}{\partial \theta} \right|} = \cos \theta \cos \phi \bar{i} + \cos \theta \sin \phi \bar{j} - \sin \theta \bar{k} \quad \dots(2)\end{aligned}$$

$$\bar{e}_3 = \bar{e}_\phi = \frac{\frac{\partial \bar{R}}{\partial \phi}}{\left| \frac{\partial \bar{R}}{\partial \phi} \right|} = -\sin \phi \bar{i} + \cos \phi \bar{j} \quad \dots(3)$$

From (1), (2) and (3)

$$\bar{e}_1 \cdot \bar{e}_2 = \bar{e}_2 \cdot \bar{e}_3 = \bar{e}_3 \cdot \bar{e}_1 = 0$$

Hence the spherical system is orthogonal in which case

$$\bar{e}_r = \bar{E}_r, \bar{e}_\theta = \bar{E}_\theta \text{ and } \bar{e}_\phi = \bar{E}_\phi.$$

**Example 4.** Obtain expression for  $\text{grad } \alpha$ ,  $\text{Div } \bar{A}$  and  $\text{curl } \bar{A}$  in spherical coordinates.

**Solution.** For spherical coordinates

$$u_1 = r, \quad u_2 = \theta, \quad u_3 = \phi, \quad h_1 = 1, \quad h_2 = r, \quad h_3 = r \sin \theta$$

Let  $\bar{A} = A_1 \bar{e}_1 + A_2 \bar{e}_2 + A_3 \bar{e}_3$

(i) Expression for  $\text{grad } \alpha$ ,

$$\text{grad } \alpha = \frac{\bar{e}_1}{h_1} \frac{\partial \alpha}{\partial u_1} + \frac{\bar{e}_2}{h_2} \frac{\partial \alpha}{\partial u_2} + \frac{\bar{e}_3}{h_3} \frac{\partial \alpha}{\partial u_3}$$

Substituting for  $h_1, h_2, h_3$  and  $u_1, u_2, u_3$  we have

$$\text{grad } \alpha = \bar{e}_r \frac{\partial \alpha}{\partial r} + \frac{\bar{e}_\theta}{r} \frac{\partial \alpha}{\partial \theta} + \frac{\bar{e}_\phi}{r \sin \theta} \frac{\partial \alpha}{\partial \phi}$$

(ii) Expression for Div  $\bar{A}$ 

$$\begin{aligned}\text{Div } \bar{A} &= \Delta \cdot \bar{A} \\ &= \frac{1}{h_1 h_2 h_3} \left[ \frac{\partial}{\partial u_1} (A_1 h_2 h_3) + \frac{\partial}{\partial u_2} (A_2 h_3 h_1) + \frac{\partial}{\partial u_3} (A_3 h_1 h_2) \right] \\ &= \frac{1}{r^2 \sin \theta} \left[ \frac{\partial}{\partial r} (A_1 r^2 \sin \theta) + \frac{\partial}{\partial \theta} (A_2 r \sin \theta) + \frac{\partial}{\partial \phi} (A_3 r) \right] \\ &= \frac{1}{r^2 \sin \theta} \left[ \sin \theta \frac{\partial}{\partial r} (A_1 r^2) + r \frac{\partial}{\partial \theta} (A_2 \sin \theta) + r \frac{\partial A_3}{\partial \phi} \right]\end{aligned}$$

(iii) Expression for curl  $\bar{A}$ 

$$\text{curl } \bar{A} = \frac{1}{h_1 h_2 h_3} \begin{vmatrix} h_1 \bar{e}_1 & h_2 \bar{e}_2 & h_3 \bar{e}_3 \\ \frac{\partial}{\partial u_1} & \frac{\partial}{\partial u_2} & \frac{\partial}{\partial u_3} \\ A_1 h_1 & A_2 h_2 & A_3 h_3 \end{vmatrix} = \frac{1}{r^2 \sin \theta} \begin{vmatrix} \bar{e}_r & r \bar{e}_\theta & r \sin \theta \bar{e}_\phi \\ \frac{\partial}{\partial r} & \frac{\partial}{\partial \theta} & \frac{\partial}{\partial \phi} \\ A_1 & A_2 r & A_3 r \sin \theta \end{vmatrix}$$

**Example 5.** Show that for spherical polar coordinates  $(r, \theta, \phi)$   $\text{curl} (\cos \theta \text{grad } \phi) = \text{grad} \left( \frac{1}{r} \right)$ .**Solution.** We know  $\text{curl} (\phi \bar{A}) = \phi \text{curl } \bar{A} + \text{grad } \phi \times \bar{A}$ . Hence  $\text{curl} \{(\cos \theta) (\text{grad } \phi)\} = \cos \theta \text{curl grad } \phi + \text{grad} (\cos \theta) \times \text{grad } \phi$ .But  $\text{curl grad } \phi = 0$  $\therefore$  L.H.S. =  $\text{grad} (\cos \theta) \times \text{grad } \phi$ 

$$\text{We know } \text{grad } \alpha = \frac{\bar{e}_1}{h_1} \frac{\partial \alpha}{\partial u_1} + \frac{\bar{e}_2}{h_2} \frac{\partial \alpha}{\partial u_2} + \frac{\bar{e}_3}{h_3} \frac{\partial \alpha}{\partial u_3}$$

For spherical coordinates

$$u_1 = r, u_2 = \theta, u_3 = \phi, h_1 = 1, h_2 = r, h_3 = \sin \theta$$

$$\begin{aligned}\therefore \text{grad} (\cos \theta) &= \frac{\bar{e}_1}{1} \frac{\partial}{\partial r} (\cos \theta) + \frac{\bar{e}_2}{r} \frac{\partial}{\partial \theta} (\cos \theta) + \frac{\bar{e}_3}{r \sin \theta} \frac{\partial}{\partial \phi} (\cos \theta) \\ &= -\frac{\bar{e}_2}{r} \sin \theta \quad \dots(1)\end{aligned}$$

$$\text{Since } \frac{\partial}{\partial r} (\cos \theta) = \frac{\partial}{\partial \phi} (\cos \theta) = 0$$

$$\begin{aligned} \text{Similarly, } \text{grad } \phi &= \bar{e}_1 \frac{\partial}{\partial r} (\phi) + \frac{\bar{e}_2}{r} \frac{\partial}{\partial \theta} (\phi) + \frac{\bar{e}_3}{r \sin \theta} \left( \frac{\partial}{\partial \phi} \phi \right) \\ &= \frac{\bar{e}_3}{r \sin \theta} \end{aligned} \quad \dots(2)$$

Hence L.H.S. on using (1) and (2) gives

$$-\frac{\bar{e}_2}{r} \sin \theta \times \frac{\bar{e}_3}{r \sin \theta} = -\frac{\bar{e}_1}{r^2}$$

$$\text{Since } \bar{e}_2 \times \bar{e}_3 = \bar{e}_1$$

$$\text{Similarly R.H.S.} = \text{grad} \left( \frac{1}{r} \right)$$

$$\bar{e}_1 \frac{\partial}{\partial r} \left( \frac{1}{r} \right) + \bar{e}_2 \frac{\partial}{\partial \theta} \frac{1}{r} + \frac{\bar{e}_3}{r \sin \theta} \frac{\partial}{\partial \phi} \left( \frac{1}{r} \right) = \frac{-\bar{e}_1}{r^2}$$

$$\therefore \text{L.H.S.} = \text{R.H.S.}$$

**Example 6.** Find  $J \left( \frac{x, y, z}{u_1, u_2, u_3} \right)$  in spherical coordinates.

**Solution.** For spherical coordinates  $u_1 = r$ ,  $u_2 = \theta$ ,  $u_3 = \phi$  and  $x = r \sin \theta \cos \phi$ ,  $y = r \sin \theta \sin \phi$ ,

$$z = r \cos \theta$$

Hence,

$$J \left( \frac{x, y, z}{u_1, u_2, u_3} \right) = J \left( \frac{x, y, z}{r, \theta, \phi} \right)$$

$$= \begin{vmatrix} \frac{\partial x}{\partial r} & \frac{\partial y}{\partial r} & \frac{\partial z}{\partial r} \\ \frac{\partial x}{\partial \theta} & \frac{\partial y}{\partial \theta} & \frac{\partial z}{\partial \theta} \\ \frac{\partial x}{\partial \phi} & \frac{\partial y}{\partial \phi} & \frac{\partial z}{\partial \phi} \end{vmatrix} = \begin{vmatrix} \sin \theta \cos \phi & \sin \theta \sin \phi & \cos \theta \\ r \cos \theta \cos \phi & r \cos \theta \sin \phi & -r \sin \theta \\ -r \sin \theta \sin \phi & r \sin \theta \cos \phi & 0 \end{vmatrix}$$

$$\begin{aligned} &= \sin \theta \cos \phi (r^2 \sin^2 \theta \cos \phi) - \sin \theta \sin \phi (-r^2 \sin^2 \theta \sin \phi) \\ &\quad + \cos \theta (r^2 \sin \theta \cos \theta \cos^2 \phi + r^2 \cos \theta \sin \theta \sin^2 \phi) \\ &= r^2 \sin^3 \theta \cos^2 \phi + r^2 \sin^3 \theta \sin^2 \phi + \cos^2 \theta \sin \theta r^2 \\ &= r^2 \sin^3 \theta + r^2 \sin \theta \cos^2 \theta \\ &= r^2 \sin \theta. \end{aligned}$$



### EXERCISE 4.6

1. Represent  $\bar{A} = z\bar{i} - 2x\bar{j} + y\bar{k}$  in cylindrical coordinates. Hence obtain its components in that system. [Ans.  $A_r = z \cos \theta - r \sin 2\theta$ ,  $A_\theta = -z \sin \theta - 2r \cos^2 \theta$ ,  $A_z = r \sin \theta$ ]

2. Prove that for cylindrical system  $\frac{d}{dt} \bar{e}_\theta = \frac{d\theta}{dt} \bar{e}_r$ .

3. Obtain expression for velocity  $\bar{v}$  and acceleration  $\bar{a}$  in cylindrical coordinates.

[Hint :  $\bar{r} = x\bar{i} + y\bar{j} + z\bar{k}$ . Substitute for  $x, y, z$  and  $\bar{i}, \bar{j}, \bar{k}$ .

$$\bar{V} = \frac{dr}{dt} \bar{e}_r + r \frac{d\theta}{dt} \bar{e}_\theta + \dot{z} \bar{e}_z \quad \text{and} \quad \bar{a} = \frac{d\bar{v}}{dt}$$

$$\bar{a} = (\dot{r} - r\dot{\theta}^2) \bar{e}_r + (2\dot{r}\dot{\theta} + r\ddot{\theta}) \bar{e}_\theta + \ddot{z} \bar{e}_z \quad \left[ \text{Ans. } \bar{V} = \dot{r} \bar{e}_r + r \dot{\theta} \bar{e}_\theta + \dot{z} \bar{e}_z \right]$$

Where dots denote differentiation with respect to time  $t$ .

4. Obtain an expression for  $\Delta^2 \chi$  in (i) cylindrical (ii) spherical systems.

$$\left[ \text{Ans. (i) } \frac{1}{r} \frac{\partial}{\partial r} \left( r \frac{\partial \chi}{\partial r} \right) + \frac{1}{r^2} \frac{\partial^2 \chi}{\partial \theta^2} + \frac{\partial^2 \chi}{\partial z^2} \right]$$

$$\text{(ii) } \frac{1}{r^2} \frac{\partial}{\partial r} \left( r^2 \frac{\partial \chi}{\partial r} \right) + \frac{1}{r^2} \sin \theta \frac{\partial}{\partial \theta} \left( \sin \theta \frac{\partial \chi}{\partial \theta} \right) + \frac{1}{r^2 \sin^2 \theta} \frac{\partial^2 \chi}{\partial \phi^2}$$

5. For spherical coordinates prove that

$$(i) \quad \bar{e}'_r = \dot{\theta} \bar{e}_\theta + \sin \theta \dot{\phi} \bar{e}_\phi$$

$$(ii) \quad \bar{e}'_\theta = -\dot{\theta} \bar{e}_r + \cos \theta \dot{\phi} \bar{e}_\phi$$

$$(iii) \quad \bar{e}'_\phi = -\sin \theta \dot{\phi} \bar{e}_r - \cos \theta \dot{\phi} \bar{e}_\theta$$

### ADDITIONAL PROBLEMS

1. Verify Green's theorem for  $\int_C (xy + y^2) dx + x^2 dy$  where  $C$  is the closed curve of the region bounded by the line  $y = x$  and the parabola  $y = x^2$ .

**Solution.** Refer page no. 176, Example 2.

2. Using the divergence theorem evaluate  $\iint_S \vec{F} \cdot \hat{n} ds$  where  $\vec{F} = x^3 \bar{i} + y^3 \bar{j} + z^3 \bar{k}$  and  $S$  is the surface of the sphere  $x^2 + y^2 + z^2 = a^2$ .

**Solution.** Refer page no. 185, Example 10.

3. Prove that Cylindrical coordinate system is orthogonal.

**Solution.** Refer page no. 200.

4. Evaluate  $\int_C xy \, dx + xy^2 \, dy$  by Stoke's theorem where  $C$  is the square in the  $x - y$  plane with vertices  $(1, 0)$ ,  $(-1, 0)$ ,  $(0, 1)$ ,  $(0, -1)$ .

**Solution.** We have Stoke's theorem

$$\int_C \vec{F} \cdot d\vec{r} = \iint_S \text{curl } \vec{F} \cdot d\vec{s}$$

From the given integral it is evident that

$$\vec{F} = xy \hat{i} + xy^2 \hat{j}$$

since,

$$d\vec{r} = dx \hat{i} + dy \hat{j} + dz \hat{k}$$

$$\text{Hence, } \int_C xy \, dx + xy^2 \, dy = \int_C \vec{F} \cdot d\vec{r}$$

Which is to be evaluated by applying Stoke's theorem.

$$\text{Now, } \text{curl } \vec{F} = \Delta \times \vec{F} = \begin{vmatrix} \hat{i} & \hat{j} & \hat{k} \\ \frac{\partial}{\partial x} & \frac{\partial}{\partial y} & \frac{\partial}{\partial z} \\ xy & xy^2 & 0 \end{vmatrix}$$

i.e.,  $\text{Curl } \vec{F} = (y^2 - x) \hat{k}$ , on expanding the determinant

$$\text{Further } d\vec{s} = dy \, dz \hat{i} + dz \, dx \hat{j} + dx \, dy \hat{k}$$

$$\therefore \iint_S \text{curl } \vec{F} \cdot d\vec{s} = \iint (y^2 - x) \, dx \, dy$$

It can be clearly seen from the figure that  $-1 \leq x \leq 1$  and  $-1 \leq y \leq 1$

$$\begin{aligned} \text{Now, } \iint_S \text{curl } \vec{F} \cdot d\vec{s} &= \int_{x=-1}^1 \int_{y=-1}^1 (y^2 - x) \, dy \, dx \\ &= \int_{x=-1}^1 \left[ \frac{y^3}{3} - xy \right]_{y=-1}^1 \, dx \\ &= \int_{x=-1}^1 \left[ \left( \frac{1}{3} + \frac{1}{3} \right) - x(1+1) \right] \, dx = \int_{x=-1}^1 \left( \frac{2}{3} - 2x \right) \, dx \\ &= \left[ \frac{2}{3}x - x^2 \right]_{x=-1}^1 \\ &= \frac{2}{3}(1+1) - (1-1) = \frac{4}{3} \end{aligned}$$

$$\text{Thus, } \int_C xy \, dx + x^2 \, dy = \frac{4}{3}$$

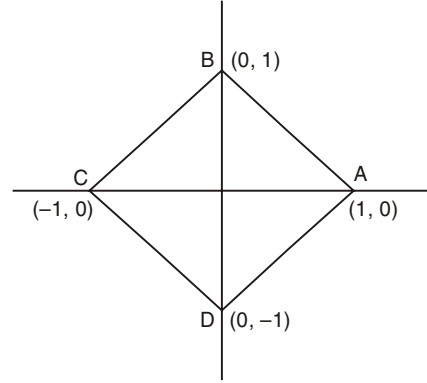

Fig. 4.10

### OBJECTIVE QUESTIONS

1. If  $\vec{F}(t)$  has a constant magnitude then

(a)  $\frac{d}{dt} \vec{F}(t) = 0$

(b)  $\vec{F}(t) \cdot \frac{d\vec{F}(t)}{dt} = 0$

(c)  $\vec{F}(t) \times \frac{d\vec{F}(t)}{dt} = 0$

(d)  $\vec{F}(t) - \frac{d\vec{F}(t)}{dt} = 0$

[Ans. b]

2. A unit vector normal to the surface  $xy^3z^2 = 4$  at the point  $(-1, -1, 2)$  is

(a)  $-\frac{1}{\sqrt{11}}(\vec{i} + 3\vec{j} - \vec{k})$

(b)  $\frac{1}{\sqrt{11}}(\vec{i} + 3\vec{j} - \vec{k})$

(c)  $-\frac{1}{\sqrt{11}}(\vec{i} + 3\vec{j} + \vec{k})$

(d)  $\frac{1}{\sqrt{11}}(\vec{i} - 3\vec{j} + \vec{k})$

[Ans. a]

3. The greatest rate of increase of  $u = x^2 + yz^2$  at the point  $(1, -1, 3)$  is

(a)  $\sqrt{79}$

(b)  $2\sqrt{79}$

(c)  $\sqrt{89}$

(d)  $4\sqrt{7}$

[Ans. c]

4. The vector grad  $\phi$  at the point  $(1, 1, 2)$  where  $\phi$  is the level surface  $xy^2z^2 = 4$  is along

(a) normal to the surface at  $(1, 1, 2)$

(b) tangent to the surface at  $(1, 1, 2)$

(c) Z-axis

(d)  $\vec{i} + \vec{j} + 2\vec{k}$

[Ans. a]

5. Directional derivative is maximum along

(a) tangent to the surface

(b) normal to the surface

(c) any unit vector

(d) coordinate ones

[Ans. b]

6. If for a vector function  $\vec{F}$ ,  $\text{div } \vec{F} = 0$  then  $\vec{F}$  is called

(a) irrotational

(b) conservative

(c) solenoidal

(d) rotational

[Ans. c]

7. For a vector function  $\vec{F}$ , there exists a scalar potential only when

(a)  $\text{div } \vec{F} = 0$

(b)  $\text{grad}(\text{div } \vec{F}) = 0$

(c)  $\text{curl } \vec{F} = 0$

(d)  $\vec{F} \text{ curl } \vec{F} = 0$

[Ans. c]

8. If  $\vec{a}$  is a constant vector and  $\vec{r} = x\vec{i} + y\vec{j} + z\vec{k}$ , then  $\Delta \times (\vec{a} \times \vec{r})$  is equal to

(a) 0

(b)  $\vec{a}$

(c)  $2\vec{a}$

(d)  $-2\vec{a}$

[Ans. c]

9. Which of the following is true

$$(a) \operatorname{curl}(\vec{A} \cdot \vec{B}) = \operatorname{curl} \vec{A} + \operatorname{curl} \vec{B} \quad (b) \operatorname{div} \operatorname{curl} \vec{A} = \nabla \cdot \vec{A}$$

$$(c) \operatorname{div}(\vec{A} \cdot \vec{B}) = \operatorname{div} \vec{A} \cdot \operatorname{div} \vec{B} \quad (d) \operatorname{div} \operatorname{curl} \vec{A} = 0$$

[Ans. d]

10. Using the following integral, work done by a force  $\vec{F}$  can be calculated:

(a) Line integral (b) Surface integral

(c) Volume integral (d) None of these

[Ans. a]

11. If  $\vec{F}$  is the velocity of a fluid particle then  $\int_C \vec{F} \cdot d\vec{r}$  represents

(a) work done (b) circulation

(c) flux (d) conservative field

[Ans. b]

12. The well-known equations of poisson and Laplace hold good for every

(a) rotational field (b) solenoidal field

(c) irrotational field (d) compressible field

[Ans. c]

13. If the vector functions  $\vec{F}$  and  $\vec{G}$  are irrotational, then  $\vec{F} \times \vec{G}$  is

(a) irrotational (b) solenoidal

(c) both irrotational and solenoidal (d) none of these

[Ans. b]

14. The gradient of a differentiable scalar field is

(a) irrotational (b) solenoidal

(c) both irrotational and solenoidal (d) none of these

[Ans. a]

15. Gauss Divergence theorem is a relation between

(a) a line integral and a surface integral

(b) a surface integral and a volume integral

(c) a line integral and a volume integral

(d) two volume integrals

[Ans. b]

16. Green's theorem in the plane is applicable to

(a)  $xy$ -plane (b)  $yz$ -plane

(c)  $zx$ -plane (d) all of these

[Ans. d]

17. If all the surfaces are closed in a region containing volume  $V$  then the following theorem is applicable

(a) Stoke's theorem (b) Green's theorem

(c) Gauss divergence theorem (d) only (a) and (b)

[Ans. c]

18. The value of  $\int_C [(2x - y) dx + (x + 3y) dy]$  where  $C : x^2 + 4y^2 = 4$  is
- (a) 0 (b) 4  
(c)  $2\pi$  (d)  $4\pi$  [Ans. d]
19. The magnitude of the vector drawn in a direction perpendicular to the surface  $x^2 + 2y^2 + z^2 = 7$  at the point  $(1, -1, 2)$  is
- (a)  $\frac{2}{3}$  (b)  $\frac{3}{2}$   
(c) 3 (d) 6 [Ans. d]
20. A unit normal to the surface  $z = 2xy$  at the point  $(2, 1, 4)$  is
- (a)  $2i + 4j - k$  (b)  $2j + 4j + k$   
(c)  $\frac{1}{\sqrt{21}}(2i + 4j - k)$  (d)  $\frac{1}{\sqrt{21}}(4i + 2j - k)$  [Ans. c]
21. The maximum value of the directional derivative  $\phi = x^2 - 2y^2 + 4z^2$  at the point  $(1, 1, -1)$  is
- (a)  $\sqrt{\frac{7}{3}}$  (b) 84  
(c)  $6\sqrt{\frac{7}{3}}$  (d)  $3\sqrt{\frac{3}{7}}$  [Ans. c]
22. The unit normal to the surface  $x^2 + y^2 + z^2 = 1$  at the point  $\left(\frac{1}{\sqrt{2}}, \frac{1}{\sqrt{2}}, 0\right)$  is
- (a)  $\frac{1}{\sqrt{2}}(\vec{i} - \vec{j})$  (b)  $\frac{1}{\sqrt{2}}(-\vec{i} + \vec{j})$   
(c)  $\frac{1}{\sqrt{2}}(\vec{i} + \vec{j})$  (d) None of these [Ans. c]
23. The unit vector tangent to the curve  $x = t, y = t^2, z = t^3$  at the point  $(-1, 1, -1)$  is
- (a)  $\frac{1}{\sqrt{14}}(i + 2j + 3k)$  (b)  $\frac{1}{\sqrt{14}}(i - 2j + 3k)$   
(c)  $\frac{1}{\sqrt{3}}(i + j + k)$  (d)  $\frac{1}{\sqrt{3}}(i - j + k)$  [Ans. a]
24. The value of  $\text{curl}(\text{grad } f)$ , where  $f = 2x^2 - 3y^2 + 4z^2$  is
- (a)  $4x - 6y + 8z$  (b)  $4xi - 6yj + 8zk$   
(c) 0 (d) 3 [Ans. c]
25. The curl of the gradient of a scalar function  $\cup$  is
- (a) 1 (b)  $\Delta^2 \cup$   
(c)  $\nabla \cup$  (d) 0 [Ans. d]

26. A force field  $\vec{F}$  is said to be conservative if
- (a)  $\text{curl } \vec{F} = 0$  (b)  $\text{grad } \vec{F} = 0$
- (c)  $\text{div } \vec{F} = 0$  (d)  $\text{curl}(\text{grad } \vec{F}) = 0$  [Ans. d]
27. The value of the line integral  $\int \text{grad}(x + y - z) dr$  from  $(0, 1, -1)$  to  $(1, 2, 0)$  is
- (a)  $-1$  (b)  $3$
- (c)  $0$  (d) No obtainable [Ans. b]
28. A necessary and sufficient condition that line integral  $\int_C A \cdot dr = 0$  for every closed curve  $C$  is that
- (a)  $\text{div } A = 0$  (b)  $\text{curl } A = 0$
- (c)  $\text{div } A \neq 0$  (d)  $\text{curl } A \neq 0$  [Ans. b]
29. The value of the line integral  $\int_C (y^2 dx + x^2 dy)$  where  $C$  is the boundary of the square  $-1 \leq x \leq 1, -1 \leq y \leq 1$  is
- (a)  $0$  (b)  $2(x + y)$
- (c)  $4$  (d)  $\frac{4}{3}$  [Ans. a]
30. The value of the surface integral  $\iint_S (yz dy dz + zx dz dx + xy dx dy)$  where  $S$  is the surface of the sphere  $x^2 + y^2 + z^2 = 1$  is
- (a)  $\frac{4\pi}{3}$  (b)  $0$
- (c)  $4\pi$  (d)  $12\pi$  [Ans. b]
31. Let  $S$  be a closed orientable surface enclosing a unit volume. Then the magnitude of the surface integral  $\int_S \vec{r} \cdot \hat{n} ds$ , where  $r = x\hat{i} + y\hat{j} + z\hat{k}$  and  $\hat{n}$  is the unit normal to the surface  $S$ , equals.
- (a)  $1$  (b)  $2$
- (c)  $3$  (d)  $4$  [Ans. c]
32. If  $\vec{f} = ax\vec{i} + by\vec{j} + cz\vec{k}$ ,  $a, b, c$  constants then  $\iint_S f \cdot dS$  where  $S$  is the surface of a unit sphere, is
- (a)  $0$  (b)  $\frac{4}{3}\pi(a + b + c)$
- (c)  $\frac{4}{3}\pi(a + b + c)^2$  (d) None of these [Ans. b]

## **Differential Equations-I**

### **5.1 INTRODUCTION**

We have studied methods of solving ordinary differential equations of first order and first degree, in chapter-7 (Ist semester). In this chapter, we study differential equations of second and higher orders. Differential equations of second order arise very often in physical problems, especially in connection with mechanical vibrations and electric circuits.

### **5.2 LINEAR DIFFERENTIAL EQUATIONS OF SECOND AND HIGHER ORDER WITH CONSTANT COEFFICIENTS**

A differential equation of the form

$$\frac{d^n y}{dx^n} + a_1 \frac{d^{n-1} y}{dx^{n-1}} + a_2 \frac{d^{n-2} y}{dx^{n-2}} + \dots + a_n y = X \quad \dots(1)$$

where  $X$  is a function of  $x$  and  $a_1, a_2, \dots, a_n$  are constants is called a linear differential equation of  $n^{\text{th}}$  order with constant coefficients. Since the highest order of the derivative appearing in (1) is  $n$ , it is called a differential equation of  $n^{\text{th}}$  order and it is called linear.

Using the familiar notation of differential operators:

$$D = \frac{d}{dx}, \quad D^2 = \frac{d^2}{dx^2}, \quad D^3 = \frac{d^3}{dx^3}, \dots, \quad D^n = \frac{d^n}{dx^n}$$

Then (1) can be written in the form

$$\{D^n + a_1 D^{n-1} + a_2 D^{n-2} + \dots + a_n\} y = X$$

*i.e.,*  $f(D) y = X \quad \dots(2)$

where  $f(D) = D^n + a_1 D^{n-1} + a_2 D^{n-2} + \dots + a_n$ .

Here  $f(D)$  is a polynomial of degree  $n$  in  $D$

If  $x = 0$ , the equation

$$f(D) y = 0$$

is called a homogeneous equation.

If  $x \neq 0$  then the Eqn. (2) is called a non-homogeneous equation.

## 5.3

## SOLUTION OF A HOMOGENEOUS SECOND ORDER LINEAR DIFFERENTIAL EQUATION

We consider the homogeneous equation

$$\frac{d^2y}{dx^2} + p \frac{dy}{dx} + qy = 0 \quad \dots(1)$$

where  $p$  and  $q$  are constants

$$(D^2 + pD + q) y = 0 \quad \dots(2)$$

The Auxiliary equations (A.E.) put  $D = m$

$$m^2 + pm + q = 0 \quad \dots(3)$$

Eqn. (3) is called auxiliary equation (A.E.) or characteristic equation of the D.E. eqn. (3) being quadratic in  $m$ , will have two roots in general. There are three cases.

**Case (i):** Roots are real and distinct

The roots are real and distinct, say  $m_1$  and  $m_2$  i.e.,  $m_1 \neq m_2$

Hence, the general solution of eqn. (1) is

$$y = C_1 e^{m_1 x} + C_2 e^{m_2 x}$$

where  $C_1$  and  $C_2$  are arbitrary constant.

**Case (ii):** Roots are equal

The roots are equal i.e.,  $m_1 = m_2 = m$ .

Hence, the general solution of eqn. (1) is

$$y = (C_1 + C_2 x) e^{mx}$$

where  $C_1$  and  $C_2$  are arbitrary constant.

**Case (iii):** Roots are complex

The Roots are complex, say  $\alpha \pm i\beta$

Hence, the general solution is

$$y = e^{\alpha x} (C_1 \cos \beta x + C_2 \sin \beta x)$$

where  $C_1$  and  $C_2$  are arbitrary constants.

**Note.** Complementary Function (C.F.) which itself is the general solution of the D.E.

## WORKED OUT EXAMPLES

1. Solve  $\frac{d^2y}{dx^2} - 5 \frac{dy}{dx} + 6y = 0$ .

**Solution.** Given equation is  $(D^2 - 5D + 6) y = 0$

A.E. is  $m^2 - 5m + 6 = 0$

i.e.,  $(m - 2)(m - 3) = 0$

i.e.,  $m = 2, 3$

$\therefore m_1 = 2, m_2 = 3$

$\therefore$  The roots are real and distinct.



∴ The general solution of the equation is

$$y = C_1 e^{2x} + C_2 e^{3x}.$$

2. Solve  $\frac{d^3 y}{dx^3} - \frac{d^2 y}{dx^2} - 4 \frac{dy}{dx} + 4y = 0$ .

**Solution.** Given equation is  $(D^3 - D^2 - 4D + 4)y = 0$

A.E. is  $m^3 - m^2 - 4m + 4 = 0$

$$m^2(m - 1) - 4(m - 1) = 0$$

$$(m - 1)(m^2 - 4) = 0$$

$$m = 1, m = \pm 2$$

$$m_1 = 1, m_2 = 2, m_3 = -2$$

∴ The general solution of the given equation is

$$y = C_1 e^x + C_2 e^{2x} + C_3 e^{-2x}.$$

3. Solve  $\frac{d^2 y}{dx^2} - \frac{dy}{dx} - 6y = 0$ .

**Solution.** The D.E. can be written as

$$(D^2 - D - 6)y = 0$$

A.E. is  $m^2 - m - 6 = 0$

$$\therefore (m - 3)(m + 2) = 0$$

$$\therefore m = 3, -2$$

∴ The general solution is

$$y = C_1 e^{3x} + C_2 e^{-2x}.$$

4. Solve  $\frac{d^2 y}{dx^2} + 8 \frac{dy}{dx} + 16y = 0$ .

**Solution.** The D.E. can be written as

$$(D^2 + 8D + 16)y = 0$$

A.E. is  $m^2 + 8m + 16 = 0$

$$\therefore (m + 4)^2 = 0$$

$$(m + 4)(m + 4) = 0$$

$$m = -4, -4$$

∴ The general solution is

$$y = (C_1 + C_2 x) e^{-4x}.$$

5. Solve  $\frac{d^2 y}{dx^2} + w^2 y = 0$ .

**Solution.** Equation can be written as

$$(D^2 + w^2)y = 0$$

A.E. is  $m^2 + w^2 = 0$

$$m^2 = -w^2 = w^2 i^2 \quad (i^2 = -1)$$

$$m = \pm w i$$

This is the form  $\alpha \pm i\beta$  where  $\alpha = 0$ ,  $\beta = w$ .

$\therefore$  The general solution is

$$y = e^{0t} (C_1 \cos wt + C_2 \sin wt)$$

$$\therefore y = C_1 \cos wt + C_2 \sin wt.$$

6. Solve  $\frac{d^2 y}{dx^2} + 4 \frac{dy}{dx} + 13y = 0$ .

**Solution.** The equation can be written as

$$(D^2 + 4D + 13)y = 0$$

A.E. is  $m^2 + 4m + 13 = 0$

$$m = \frac{-4 \pm \sqrt{16 - 52}}{2}$$

$$= -2 \pm 3i \text{ (of the form } \alpha \pm i\beta)$$

$\therefore$  The general solution is

$$y = e^{-2x} (C_1 \cos 3x + C_2 \sin 3x).$$

7. Solve  $\frac{d^2 y}{dx^2} - \frac{dy}{dx} = 0$  given  $y'(0) = 0$ ,  $y(0) = 1$ .

**Solution.** Equation is  $(D^2 - D)y = 0$

A.E. is  $m^2 - m = 0$

$$m(m - 1) = 0$$

$$\Rightarrow m = 0, 1$$

$\therefore$  The general solution is

$$y = C_1 e^{0x} + C_2 e^x$$

i.e.,  $y = C_1 + C_2 e^x$

when

$$x = 0, y = 0 \text{ (Given)}$$

$$y(0) = 0$$

$$\Rightarrow 0 = C_1 + C_2 \quad \dots(1)$$

$$y'(x) = C_2 e^x$$

Given, when  $x = 0$ ,  $y' = 1$

$$y(0) = 1$$

$$\Rightarrow 1 = C_2 e^0$$

$$\Rightarrow C_2 = 1 \quad \dots(2)$$

From (1) and (2)  $\Rightarrow C_1 = -1$ .

$\therefore$  The general solution is  $y = e^x - 1$ .

8. Solve  $(4D^4 - 4D^3 - 23D^2 + 12D + 36) y = 0$ .

**Solution.** A.E. is  $4m^4 - 4m^3 - 23m^2 + 12m + 36 = 0$

If  $m = 2, 64 - 32 - 92 + 24 + 36 = 0$

$\Rightarrow m = 2$  is a root of inspection.

By synthetic division,

$$\begin{array}{r|rrrrr} & 4 & -4 & -23 & 12 & 36 \\ 2 & & 8 & 8 & -30 & -36 \\ \hline & 4 & 4 & -15 & -18 & 0 \end{array}$$

i.e.,  $4m^3 + 4m^2 - 15m - 18 = 0$

If  $m = 2$

$$32 + 16 - 30 - 18 = 0$$

Again  $m = 2$  is a root.

By synthetic division

$$\begin{array}{r|rrrr} & 4 & 4 & -15 & -18 \\ 2 & & 8 & 24 & 18 \\ \hline & 4 & 12 & 9 & 0 \end{array}$$

$$4m^2 + 12m + 9 = 0$$

$$(2m + 3)^2 = 0$$

$$m = \frac{-3}{2}, \frac{-3}{2}$$

$\therefore$  The roots of the A.E. are  $2, 2, \frac{-3}{2}, \frac{-3}{2}$ .

Thus,  $y = (C_1 + C_2 x) e^{2x} + (C_3 + C_4 x) e^{-3x/2}$ .

9. Solve  $(D^5 - D^4 - D + 1) y = 0$ .

**Solution.** A.E. is  $m^5 - m^4 - m + 1 = 0$

i.e.,  $m^4(m - 1) - 1(m - 1) = 0$

$$(m - 1)(m^4 - 1) = 0$$

$$(m - 1)(m^2 - 1)(m^2 + 1) = 0$$

$$(m - 1)(m - 1)(m + 1)(m^2 + 1) = 0$$

$\therefore$  The roots of the A.E. are  $1, 1, -1, \pm i$ .

Thus  $y = (C_1 + C_2 x) e^x + C_3 e^{-x} + (C_4 \cos x + C_5 \sin x)$ .

10. Solve  $y'' + 4y' + 4y = 0$  given that  $y = 0, y' = -1$  at  $x = 1$ .

**Solution.** We have  $(D^2 + 4D + 4) y = 0$

A.E. is  $m^2 + 4m + 4 = 0$

$$\therefore (m + 2)^2 = 0$$

$$\Rightarrow m = -2, -2$$

$$\text{Hence, } y = (C_1 + C_2 x) e^{-2x} \quad \dots(1)$$

$$y' = (C_1 + C_2 x) (-2 e^{-2x}) + C_2 e^{-2x} \quad \dots(2)$$

$$\text{Consider } y = 0 \text{ at } x = 1$$

Hence, Eqn. (1) becomes

$$0 = (C_1 + C_2) e^{-2}$$

$$\text{i.e., } 0 = (C_1 + C_2) \left( \frac{1}{e^2} \right)$$

$$\Rightarrow C_1 + C_2 = 0$$

$$\text{Also } y' = 1 \text{ at } x = 1$$

Hence, Eqn. (2) becomes

$$-1 = (C_1 + C_2) (-2 e^{-2}) + C_2 e^{-2}$$

$$\text{But } C_1 + C_2 = 0$$

$$\text{i.e., } -1 = C_2 e^{-2}$$

$$\text{or } C_2 = -e^{+2}$$

$$\therefore C_1 = -C_2 = e^2$$

Substituting these values in Eqn. (1), we get

$$y = e^2 (1 - x) e^{-2x} = (1 - x) e^{2(1-x)}.$$

## EXERCISE 5.1

Solve the following differential equations:

$$1. \frac{d^2 y}{dx^2} - 2 \frac{dy}{dx} + 3y = 0.$$

$$[\text{Ans. } y = C_1 e^{3x} + C_2 e^{-x}]$$

$$2. 6y'' - y' - y = 0.$$

$$[\text{Ans. } y = C_1 e^{\frac{1}{2}x} + C_2 e^{-\frac{1}{3}x}]$$

$$3. (2D^2 - D - 6) y = 0.$$

$$[\text{Ans. } y = C_1 e^{2x} + C_2 e^{-\frac{3}{2}x}]$$

$$4. (D^2 + 4D + 4) y = 0.$$

$$[\text{Ans. } y = (C_1 + C_2 x) e^{-2x}]$$

$$5. 9y'' - 6y' + y = 0.$$

$$[\text{Ans. } y = (C_1 + C_2 x) e^{\frac{1}{3}x}]$$

$$6. y'' + 9y = 0.$$

$$[\text{Ans. } y = C_1 \cos 3x + C_2 \sin 3x]$$

$$7. (D^2 - 2D + 2) y = 0.$$

$$[\text{Ans. } y = e^x (C_1 \cos x + C_2 \sin x)]$$

8.  $(D^2 + D + 1) y = 0$ .  $\left[ \text{Ans. } y = e^{-\frac{1}{2}x} \left( C_1 \cos \frac{\sqrt{3}}{2} x + C_2 \sin \frac{\sqrt{3}}{2} x \right) \right]$
9.  $y'' + 4y' + 5y = 0$ .  $\left[ \text{Ans. } y = e^{-2x} (C_1 \cos x + C_2 \sin x) \right]$
10.  $(D^3 - 8) y = 0$ .  $\left[ \text{Ans. } y = C_1 e^{2x} + e^{-x} (C_2 \cos \sqrt{3} x + C_3 \sin \sqrt{3} x) \right]$
11.  $(D^3 + 6D^2 + 11D + 6) y = 0$ .  $\left[ \text{Ans. } y = C_1 e^{-x} + C_2 e^{-2x} + C_3 e^{-3x} \right]$
12.  $(D^3 - 4D^2 + 5D - 2) y = 0$ .  $\left[ \text{Ans. } y = (C_1 + C_2 x) e^x + C_3 e^{2x} \right]$
13.  $(D^3 + 6D^2 + 12D + 8) y = 0$ .  $\left[ \text{Ans. } y = (C_1 + C_2 x + C_3 x^2) e^{-2x} \right]$
14.  $(D^4 - 2D^3 + 5D^2 - 8D + 4) y = 0$ .  $\left[ \text{Ans. } y = (C_1 + C_2 x) e^x + C_3 \cos 2x + C_4 \sin 2x \right]$
15.  $(D^4 - 4D^3 + 8D^2 - 8D + 4) y = 0$ .  $\left[ \text{Ans. } y = e^x [(C_1 + C_2 x) \cos x + (C_3 + C_4 x) \sin x] \right]$
16.  $(D^4 - D^3 - 9D^2 - 11D - 4) y = 0$ .  $\left[ \text{Ans. } y = (C_1 + C_2 x + C_3 x^2) e^{-x} + C_4 e^{4x} \right]$

## 5.4 INVERSE DIFFERENTIAL OPERATOR AND PARTICULAR INTEGRAL

Consider a differential equation

$$f(D) y = x \quad \dots(1)$$

Define  $\frac{1}{f(D)}$  such that

$$f(D) \left\{ \frac{1}{f(D)} \right\} x = x \quad \dots(2)$$

Here  $f(D)$  is called the inverse differential operator. Hence from Eqn. (1), we obtain

$$y = \frac{1}{f(D)} x \quad \dots(3)$$

Since this satisfies the Eqn. (1) hence the particular integral of Eqn. (1) is given by Eqn. (3)

$$\text{Thus, particular Integral (P.I.)} = \frac{1}{f(D)} x$$

The inverse differential operator  $\frac{1}{f(D)}$  is linear.

$$\text{i.e., } \frac{1}{f(D)} \{ax_1 + bx_2\} = a \frac{1}{f(D)} x_1 + b \frac{1}{f(D)} x_2$$

where  $a, b$  are constants and  $x_1$  and  $x_2$  are some functions of  $x$ .

## 5.5 SPECIAL FORMS OF X

**Type 1:** P.I. of the form  $\frac{e^{ax}}{f(D)}$

We have the equation  $f(D) y = e^{ax}$

Let  $f(D) = D^2 + a_1 D + a_2$

We have  $D(e^{ax}) = a e^{ax}$ ,  $D^2(e^{ax}) = a^2 e^{ax}$  and so on.

$$\begin{aligned} \therefore f(D) e^{ax} &= (D^2 + a_1 D + a_2) e^{ax} \\ &= a^2 e^{ax} + a_1 \cdot a e^{ax} + a_2 e^{ax} \\ &= (a^2 + a_1 \cdot a + a_2) e^{ax} = f(a) e^{ax} \end{aligned}$$

Thus  $f(b) e^{ax} = f(a) e^{ax}$

Operating with  $\frac{1}{f(D)}$  on both sides

We get, 
$$e^{ax} = f(a) \cdot \frac{1}{f(D)} \cdot e^{ax}$$

or 
$$\text{P.I.} = \frac{1}{f(D)} e^{ax} = \frac{e^{ax}}{f(D)}$$

In particular if  $f(D) = D - a$ , then using the general formula.

We get, 
$$\frac{1}{D-a} e^{ax} = \frac{e^{ax}}{(D-a)\phi(D)} = \frac{1}{D-a} \cdot \frac{e^{ax}}{\phi(a)}$$

i.e., 
$$\frac{e^{ax}}{f(D)} = \frac{1}{\phi(a)} e^{ax} \int 1 \cdot dx = \frac{1}{\phi(a)} \cdot x e^{ax} \quad \dots(1)$$

$\therefore f(a) = 0 + \phi(a)$

or 
$$f(a) = \phi(a)$$

Thus, Eqn. (1) becomes

$$\frac{e^{ax}}{f(D)} = x \cdot \frac{e^{ax}}{f'(D)}$$

where  $f(a) = 0$

and  $f'(a) \neq 0$

This result can be extended further also if

$$f(a) = 0, \frac{e^{ax}}{f(D)} = x^2 \cdot \frac{e^{ax}}{f''(a)} \text{ and so on.}$$

**Type 2:** P.I. of the form  $\frac{\sin ax}{f(D)}, \frac{\cos ax}{f(D)}$

We have  $D(\sin ax) = a \cos ax$

$$\begin{aligned}
 D^2 (\sin ax) &= -a^2 \sin ax \\
 D^3 (\sin ax) &= -a^3 \cos ax \\
 D^4 (\sin ax) &= a^4 \sin ax \\
 &= (-a^2)^2 \sin ax \text{ and so on.}
 \end{aligned}$$

Therefore, if  $f(D^2)$  is a rational integral function of  $D^2$  then  $f(D^2) \sin ax = f(-a^2) \sin ax$ .

$$\text{Hence } \frac{1}{f(D^2)} \{f(D^2) \sin ax\} = \frac{1}{f(D^2)} f(-a^2) \sin ax$$

$$\text{i.e., } \sin ax = f(-a^2) \frac{1}{f(D^2)} \sin ax$$

$$\text{i.e., } \frac{1}{f(D^2)} \sin ax = \frac{\sin ax}{f(-a^2)}$$

$$\text{Provided } f(-a^2) \neq 0 \quad \dots(1)$$

Similarly, we can prove that

$$\frac{1}{f(D^2)} \cos ax = \frac{\cos ax}{f(-a^2)}$$

$$\text{if } f(-a^2) \neq 0$$

$$\text{In general, } \frac{1}{f(D^2)} \cos ax = \frac{\cos ax}{f(-a^2)}$$

$$\text{if } f(-a^2) \neq 0 \quad \dots(2)$$

$$\frac{1}{f(D^2)} \sin(ax+b) = \frac{1}{f(-a^2)} \sin(ax+b)$$

$$\text{and } \frac{1}{f(D^2)} \cos(ax+b) = \frac{1}{f(-a^2)} \cos(ax+b)$$

These formula can be easily remembered as follows.

$$\frac{1}{D^2 + a^2} \sin ax = \frac{x}{2} \int \sin ax \, dx = \frac{-x}{2a} \cos ax$$

$$\frac{1}{D^2 + a^2} \cos ax = \frac{x}{2} \int \cos ax \, dx = \frac{x}{2a} \sin ax.$$

**Type 3:** P.I. of the form  $\frac{\phi(x)}{f(D)}$  where  $\phi(x)$  is a polynomial in  $x$ , we seeking the polynomial Eqn. as the particular solution of

$$f(D)y = \phi(x)$$

$$\text{where } \phi(x) = a_0 x^n + a_1 x^{n-1} + \dots + a_{n-1} x + a_n$$

Hence P.I. is found by divisor. By writing  $\phi(x)$  in descending powers of  $x$  and  $f(D)$  in ascending powers of  $D$ . The division get completed without any remainder. The quotient so obtained in the process of division will be particular integral.

**Type 4:** P.I. of the form  $\frac{e^{ax} V}{f(D)}$  where  $V$  is a function of  $x$ .

We shall prove that  $\frac{1}{f(D)} e^{ax} V = e^{ax} \frac{1}{f(D+a)} V$ .

Consider 
$$\begin{aligned} D(e^{ax} V) &= e^{ax} DV + Va e^{ax} \\ &= e^{ax} (D+a) V \end{aligned}$$

and 
$$\begin{aligned} D^2(e^{ax} V) &= e^{ax} D^2 V + a e^{ax} DV + a^2 e^{ax} V + a e^{ax} DV \\ &= e^{ax} (D^2 V + 2a DV + a^2 V) \\ &= e^{ax} (D+a)^2 V \end{aligned}$$

Similarly,  $D^3(e^{ax} V) = e^{ax} (D+a)^3 V$  and so on.

$\therefore f(D) e^{ax} V = e^{ax} f(D+a) V \quad \dots(1)$

Let  $f(D+a) V = U$ , so that  $V = \frac{1}{f(D+a)} U$

Hence (1) reduces to

$$f(D) e^{ax} \frac{1}{f(D+a)} U = e^{ax} U$$

Operating both sides by  $\frac{1}{f(D)}$  we get,

$$e^{ax} \frac{1}{f(D+a)} U = \frac{1}{f(D)} e^{ax} U$$

i.e., 
$$\frac{1}{f(D)} e^{ax} U = e^{ax} \frac{1}{f(D+a)} U$$

Replacing  $U$  by  $V$ , we get the required result.

**Type 5:** P.I. of the form  $\frac{xV}{f(D)}, \frac{x^n V}{f(D)}$  where  $V$  is a function of  $x$ .

By Leibniz's theorem, we have

$$\begin{aligned} D^n(xV) &= x D^n V + n \cdot 1 D^{n-1} V \\ &= x D^n V + \left\{ \frac{d}{dD} D^n \right\} V \end{aligned}$$

$\therefore f(D) xV = x f(D) V + f'(D) V \quad \dots(1)$

Eqn. (1) reduces to

$$\frac{xV}{f(D)} = \left[ x - \frac{f'(D)}{f(D)} \right] \frac{V}{f(D)} \quad \dots(2)$$

This is formula for finding the particular integral of the functions of the  $xV$ . By repeated application of this formula, we can find P.I. as  $x^2 V, x^3 V \dots$  .



### WORKED OUT EXAMPLES

#### Type 1

1. Solve  $\frac{d^2y}{dx^2} - 5\frac{dy}{dx} + 6y = e^{5x}$ .

**Solution.** We have

$$(D^2 - 5D + 6)y = e^{5x}$$

A.E. is  $m^2 - 5m + 6 = 0$

i.e.,  $(m - 2)(m - 3) = 0$

$\Rightarrow m = 2, 3$

Hence the complementary function is

$\therefore$  C.F. =  $C_1 e^{2x} + C_2 e^{3x}$

Particular Integral (P.I.) is

$$\begin{aligned} \text{P.I.} &= \frac{1}{D^2 - 5D + 6} e^{5x} && (D \rightarrow 5) \\ &= \frac{1}{5^2 - 5 \times 5 + 6} e^{5x} = \frac{e^{5x}}{6}. \end{aligned}$$

$\therefore$  The general solution is given by

$$\begin{aligned} y &= \text{C.F.} + \text{P.I.} \\ &= C_1 e^{2x} + C_2 e^{3x} + \frac{e^{5x}}{6}. \end{aligned}$$

2. Solve  $\frac{d^2y}{dx^2} - 3\frac{dy}{dx} + 2y = 10e^{3x}$ .

**Solution.** We have

$$(D^2 - 3D + 2)y = 10e^{3x}$$

A.E. is  $m^2 - 3m + 2 = 0$

i.e.,  $(m - 2)(m - 1) = 0$

$m = 2, 1$

C.F. =  $C_1 e^{2x} + C_2 e^x$

$$\begin{aligned} \text{P.I.} &= \frac{1}{D^2 - 3D + 2} 10e^{3x} && (D \rightarrow 3) \\ &= \frac{1}{3^2 - 3 \times 3 + 2} 10e^{3x} \end{aligned}$$

$$\text{P.I.} = \frac{10e^{3x}}{2}$$

$\therefore$  The general solution is

$$\begin{aligned} y &= \text{C.F.} + \text{P.I.} \\ &= C_1 e^{2x} + C_2 e^x + \frac{10e^{3x}}{2}. \end{aligned}$$

3. Solve  $\frac{d^2 y}{dx^2} - 4 \frac{dy}{dx} + 4y = e^{2x}$ .

**Solution.** Given equation is

$$(D^2 - 4D + 4)y = e^{2x}$$

A.E. is  $m^2 - 4m + 4 = 0$

i.e.,  $(m - 2)(m - 2) = 0$

$$m = 2, 2$$

$$\text{C.F.} = (C_1 + C_2) e^{2x}$$

$$\text{P.I.} = \frac{1}{D^2 - 4D + 4} e^{2x} \quad (D = 2)$$

$$= \frac{1}{2^2 - 4(2) + 4} e^{2x} \quad (Dr = 0)$$

Differentiate the denominator and multiply 'x'

$$= x \cdot \frac{1}{2D - 4} e^{2x} \quad (D \rightarrow 2)$$

$$= x \cdot \frac{1}{2(2) - 4} e^{2x} \quad (Dr = 0)$$

Again differentiate denominator and multiply 'x'

$$= x^2 \frac{1}{2} e^{2x}$$

$$\text{P.I.} = \frac{x^2 e^{2x}}{2}$$

$$y = \text{C.F.} + \text{P.I.} = (C_1 + C_2 x) e^{2x} + \frac{x^2 e^{2x}}{2}.$$

4. Solve  $\frac{d^4 x}{dt^4} + 4x = \cosh t$ .

**Solution.** We have

$$(D^4 + 4)x = \cosh t$$

A.E. is  $m^4 + 4 = 0$

i.e.,  $(m^2 + 2)^2 - 4m^2 = 0$

or  $[(m^2 + 2) - 2m][m^2 + 2 + 2m] = 0$

$$m^2 - 2m + 2 = 0; m^2 + 2m + 2 = 0$$

$$\therefore m = \frac{2 \pm \sqrt{4 - 8}}{2}; m = \frac{-2 \pm \sqrt{4 - 8}}{2}$$

$$m = \frac{2 \pm 2i}{2}; m = \frac{-2 \pm 2i}{2}$$

$$m = 1 \pm i, m = -1 \pm i$$

$$\text{C.F.} = e^t (C_1 \cos t + C_2 \sin t) + e^{-t} (C_3 \cos t + C_4 \sin t)$$

$$\text{P.I.} = \frac{\cosh t}{D^4 + 4}$$

$$\text{where } \cos ht = \frac{e^t + e^{-t}}{2}$$

$$= \frac{1}{2} \left[ \frac{e^t + e^{-t}}{D^4 + 4} \right]$$

$$= \frac{1}{2} \left[ \frac{e^t}{D^4 + 4} \right] + \frac{1}{2} \left[ \frac{e^{-t}}{D^4 + 4} \right]$$

$D \rightarrow 1 \qquad D \rightarrow -1$

$$= \frac{1}{2} \left[ \frac{e^t}{5} + \frac{e^{-t}}{5} \right] = \frac{1}{5} \cdot \frac{1}{2} (e^t + e^{-t}) = \frac{1}{5} \cosh t$$

$$y = \text{C.F.} + \text{P.I.}$$

$$= e^t (C_1 \cos t + C_2 \sin t) + e^{-t} (C_3 \cos t + C_4 \sin t) + \frac{1}{5} \cos ht.$$

5. Solve  $\frac{d^3 y}{dx^3} - y = (e^x + 1)^2$ .

**Solution.** Given equation can be written as

$$(D^3 - 1) y = e^{2x} + 2e^x + 1$$

A.E. is  $m^3 - 1 = 0$

i.e.,  $(m - 1)(m^2 + m + 1) = 0$

Hence,  $m = 1$

$$D = \frac{-1 \pm \sqrt{3}i}{2}$$

$$\text{C.F.} = C_1 e^x + e^{-\frac{1}{2}x} \left( C_2 \cos \frac{\sqrt{3}}{2}x + C_3 \sin \frac{\sqrt{3}}{2}x \right)$$

$$\text{P.I.} = \frac{1}{D^3 - 1} (e^{2x} + 2e^x + 1)$$

$$= \frac{1}{D^3 - 1} e^{2x} + \frac{1}{D^3 - 1} 2e^x + \frac{1}{D^3 - 1} e^0$$

$$= \text{P.I.}_1 + \text{P.I.}_2 + \text{P.I.}_3$$

$$\text{P.I.}_1 = \frac{e^{2x}}{D^3 - 1} \qquad D \rightarrow 2$$

$$= \frac{e^{2x}}{2^3 - 1} = \frac{e^{2x}}{7}$$

$$\text{P.I.}_2 = \frac{1}{D^3 - 1} 2e^x \quad (D \rightarrow 1)$$

$$= \frac{1}{1^3 - 1} 2e^x \quad (Dr = 0)$$

Differentiate the  $Dr$  and multiply  $x$

$$= \frac{2xe^x}{3D^2} \quad (D \rightarrow 1)$$

$$\text{P.I.}_2 = x \cdot \frac{2e^x}{3}$$

$$\text{P.I.}_3 = \frac{1}{D^3 - 1} e^0 \quad (D \rightarrow 1)$$

$$= -1$$

$$\text{P.I.} = \frac{e^{2x}}{7} + \frac{2xe^x}{3} - 1$$

$\therefore$  The general solution is

$$y = \text{C.F.} + \text{P.I.}$$

$$= C_1 e^x + e^{-\frac{1}{2}x} \left[ C_2 \cos \frac{\sqrt{3}}{2} x + C_3 \sin \frac{\sqrt{3}}{2} x \right] + \frac{e^{2x}}{7} + \frac{2}{3} x e^x - 1$$

6. Solve  $(D^3 + 2D^2 - D - 2)y = 2 \cos h x$ .

**Solution.** Given equation is

$$(D^3 + 2D^2 - D - 2)y = 2 \cosh x$$

$$\text{A.E. is } m^3 + 2m^2 - m - 2 = 0$$

$$m^2(m+2) - 1(m+2) = 0$$

$$(m+2)(m^2 - 1) = 0$$

$$(m+2)(m+1)(m-1) = 0$$

$$m = -2, -1, 1$$

$$\text{C.F.} = C_1 e^{-2x} + C_2 e^{-x} + C_3 e^x$$

$$\text{P.I.} = \frac{1}{D^3 + 2D^2 - D - 2} 2 \cos h x \quad \left( \text{where } \cos h x = \frac{e^x + e^{-x}}{2} \right)$$

$$= \frac{2}{D^3 + 2D^2 - D - 2} \left( \frac{e^x + e^{-x}}{2} \right)$$

$$= \frac{e^x}{D^3 + 2D^2 - D - 2} + \frac{e^{-x}}{D^3 + 2D^2 - D - 2}$$

$$= \text{P.I.}_1 + \text{P.I.}_2$$

$$\text{P.I.}_1 = \frac{e^x}{D^3 + 2D^2 - D - 2} \quad (D \rightarrow 1)$$

$$= \frac{1}{1^3 + 2(1)^2 - 1 - 2} e^x \quad (Dr = 0)$$

$$= \frac{x e^x}{3D^2 + 4D - 1} \quad (D \rightarrow 1)$$

$$= \frac{x e^x}{6}$$

$$\text{P.I.}_2 = \frac{1}{D^3 + 2D^2 - D - 2} e^{-x} \quad (D \rightarrow -1)$$

$$= \frac{1}{(-1)^3 + 2(-1)^2 - (-1) - 2} e^{-x} \quad (Dr = 0)$$

$$= \frac{x}{3D^2 + 4D - 1} e^{-x} \quad (D \rightarrow -1)$$

$$= \frac{-x e^{-x}}{2}$$

$$\text{P.I.} = \frac{x e^x}{6} - \frac{x e^{-x}}{2}$$

∴

$$y = \text{C.F.} + \text{P.I.}$$

$$= C_1 e^{-2x} + C_2 e^{-x} + C_3 e^x + \frac{x e^x}{6} - \frac{x e^{-x}}{2}$$

## Type 2

1. Solve  $(D^2 + 9) y = \cos 4x$ .

**Solution.** Given equation is  $(D^2 + 9) y = \cos 4x$

A.E. is  $m^2 + 9 = 0$

i.e.,  $m = \pm 3i$

$$\text{C.F.} = C_1 \cos 3x + C_2 \sin 3x$$

$$\text{P.I.} = \frac{1}{D^2 + 9} \cos 4x \quad (D^2 \rightarrow -4^2 = -16)$$

$$= \frac{1}{-16 + 9} \cos 4x = -\frac{1}{7} \cos 4x$$

∴ The general solution is

$$y = \text{C.F.} + \text{P.I.}$$

$$= C_1 \cos 3x + C_2 \sin 3x - \frac{1}{7} \cos 4x.$$

2. Solve  $(D^2 + D + 1) y = \sin 2x$ .

**Solution.** The A.E. is

$$m^2 + m + 1 = 0$$

$$\text{i.e., } m = \frac{-1 \pm \sqrt{1-4}}{2} = \frac{-1 \pm \sqrt{3}i}{2}$$

Hence the C.F. is

$$\text{C.F.} = e^{-\frac{x}{2}} \left[ C_1 \cos \frac{\sqrt{3}}{2} x + C_2 \sin \frac{\sqrt{3}}{2} x \right]$$

$$\begin{aligned} \text{P.I.} &= \frac{1}{D^2 + D + 1} \sin 2x && (D^2 \rightarrow -2^2) \\ &= \frac{1}{-2^2 + D + 1} \sin 2x \\ &= \frac{1}{D - 3} \sin 2x \end{aligned}$$

Multiplying and dividing by  $(D + 3)$

$$\begin{aligned} &= \frac{(D + 3) \sin 2x}{D^2 - 9} \\ &= \frac{(D + 3) \sin 2x}{-2^2 - 9} = \frac{-1}{13} (2 \cos 2x + 3 \sin 2x) \end{aligned}$$

$$\therefore y = \text{C.F.} + \text{P.I.} = e^{-\frac{x}{2}} \left[ C_1 \cos \frac{\sqrt{3}}{2} x + C_2 \sin \frac{\sqrt{3}}{2} x \right] - \frac{1}{3} (2 \cos 2x + 3 \sin 2x).$$

3. Solve  $(D^2 + 5D + 6) y = \cos x + e^{-2x}$ .

**Solution.** The A.E. is

$$m^2 + 5m + 6 = 0$$

$$\text{i.e., } (m + 2)(m + 3) = 0$$

$$m = -2, -3$$

$$\text{C.F.} = C_1 e^{-2x} + C_2 e^{-3x}$$

$$\begin{aligned} \text{P.I.} &= \frac{1}{D^2 + 5D + 6} \cdot [\cos x + e^{-2x}] \\ &= \frac{\cos x}{D^2 + 5D + 6} + \frac{e^{-2x}}{D^2 + 5D + 6} \\ &= \text{P.I.}_1 + \text{P.I.}_2 \end{aligned}$$

$$\begin{aligned} \text{P.I.}_1 &= \frac{\cos x}{D^2 + 5D + 6} && (D^2 = -1^2) \\ &= \frac{\cos x}{-1^2 + 5D + 6} = \frac{\cos x}{5D + 5} \end{aligned}$$

$$= \frac{1}{5} \frac{\cos x (D-1)}{(D+1)(D-1)}$$

$$= \frac{1}{5} \frac{(D-1) \cos x}{D^2 - 1}$$

$$= \frac{1}{5} \frac{-\sin x - \cos x}{-1^2 - 1}$$

$$= \frac{-1}{5} \frac{\sin x + \cos x}{-2}$$

$$= \frac{1}{10} (\sin x + \cos x)$$

$$\text{P.I.}_2 = \frac{e^{-2x}}{D^2 + 5D + 6} \quad (D \rightarrow -2)$$

$$= \frac{e^{-2x}}{(-2)^2 + 5 \times -2 + 6} \quad (Dr = 0)$$

Differential and multiply 'x'

$$= \frac{x e^{-2x}}{2D + 5} \quad (D \rightarrow -2)$$

$$= \frac{x e^{-2x}}{2(-2) + 5} = \frac{x e^{-2x}}{1} = x e^{-2x}$$

$$\text{P.I.} = \frac{1}{10} (\sin x + \cos x) + x e^{-2x}$$

∴ The general solution is

$$y = \text{C.F.} + \text{P.I.}$$

$$y = C_1 e^{-2x} + C_2 e^{-3x} + \frac{1}{10} (\sin x + \cos x) + x e^{-2x}.$$

4. Solve  $(D^2 + 3D + 2) y = \cos^2 x$ .

**Solution.** The A.E. is

$$m^2 + 3m + 2 = 0$$

$$\text{i.e.,} \quad (m + 1)(m + 2) = 0$$

$$\therefore \quad m = -1, -2$$

$$\text{C.F.} = C_1 e^{-x} + C_2 e^{-2x}$$

$$\text{P.I.} = \frac{1}{D^2 + 3D + 2} \cdot \cos^2 x$$

where

$$\cos^2 x = \frac{1 + \cos 2x}{2}$$

$$\begin{aligned}
&= \frac{1}{D^2 + 3D + 2} \left[ \frac{1 + \cos 2x}{2} \right] \\
&= \frac{1}{2} \left[ \frac{1}{D^2 + 3D + 2} e^{0x} + \frac{1}{D^2 + 3D + 2} \cos 2x \right] \\
&= \frac{1}{2} [\text{P.I.}_1 + \text{P.I.}_2]
\end{aligned}$$

$$\text{P.I.}_1 = \frac{e^{0x}}{D^2 + 3D + 2} \quad (D \rightarrow 0)$$

$$= \frac{e^{0x}}{2} = \frac{1}{2}$$

$$\text{P.I.}_2 = \frac{\cos 2x}{D^2 + 3D + 2} \quad (D^2 \rightarrow -2^2)$$

$$= \frac{\cos 2x}{-2^2 + 3D + 2}$$

$$= \frac{\cos 2x}{3D - 2} \times \frac{3D + 2}{3D + 2}$$

$$= \frac{(3D + 2) \cos 2x}{9D^2 - 4} \quad (D^2 \rightarrow -2^2)$$

$$= \frac{-3 \sin 2x \cdot (2) + 2 \cos 2x}{9(-2)^2 - 4}$$

$$= \frac{-6 \sin 2x + 2 \cos 2x}{-40}$$

$$= \frac{6 \sin 2x - 2 \cos 2x}{40} = \frac{3 \sin 2x - \cos 2x}{20}$$

$$\text{P.I.} = \frac{1}{2} \left[ \frac{1}{2} + \frac{3 \sin 2x - \cos 2x}{20} \right]$$

$$= \frac{1}{4} + \frac{3 \sin 2x - \cos 2x}{40}$$

$$y = \text{C.F.} + \text{P.I.}$$

$$= C_1 e^{-x} + C_2 e^{-2x} + \frac{1}{4} + \frac{1}{40} (3 \sin 2x - \cos 2x).$$



5. Solve  $(D^3 + D^2 - D - 1) y = \cos 2x$ .

**Solution.** The A.E. is

$$m^3 + m^2 - m - 1 = 0$$

$$\text{i.e., } m^2(m + 1) - 1(m + 1) = 0$$

$$(m + 1)(m^2 - 1) = 0$$

$$m = -1, m^2 = 1$$

$$m = -1, m = \pm 1$$

$$\therefore m = -1, -1, 1$$

$$\text{C.F.} = C_1 e^x + (C_2 + C_3 x) e^{-x}$$

$$\text{P.I.} = \frac{1}{D^3 + D^2 - D - 1} \cos 2x \quad (D^2 \rightarrow -2^2)$$

$$= \frac{1}{(D+1)(D^2-1)} \cos 2x$$

$$= \frac{1}{(D+1)(-2^2-1)} \cos 2x$$

$$= \frac{-1}{5} \frac{1}{D+1} \cos 2x$$

$$= \frac{-1}{5} \frac{\cos 2x}{D+1} \times \frac{D-1}{D-1}$$

$$= \frac{-1}{5} \frac{(D-1) \cos 2x}{D^2-1} \quad (D^2 \rightarrow -2^2)$$

$$= \frac{-1}{5} \left[ \frac{-2 \sin 2x - \cos 2x}{-2^2-1} \right]$$

$$= \frac{-1}{25} (2 \sin 2x + \cos 2x)$$

$\therefore$  The general solution is

$$y = \text{C.F.} + \text{P.I.}$$

$$= C_1 e^x + (C_2 + C_3 x) e^{-x} - \frac{1}{25} (2 \sin 2x + \cos 2x).$$

6. Solve  $(D^3 + 1) y = \sin 3x - \cos^2 (1/2) x$ .

**Solution.** The A.E. is

$$m^3 + 1 = 0$$

$$\text{i.e., } (m + 1)(m^2 - m + 1) = 0$$

$$m + 1 = 0, m^2 - m + 1 = 0$$

$$m = -1$$

$$m = \frac{1 \pm \sqrt{1-4}}{2}$$

$$m = \frac{1 \pm \sqrt{3}i}{2}$$

$$\text{C.F.} = C_1 e^{-x} + e^{x/2} \left[ C_2 \cos \frac{\sqrt{3}}{2} x + C_3 \sin \frac{\sqrt{3}}{2} x \right]$$

$$\begin{aligned} \text{P.I.} &= \frac{1}{D^3+1} \left( \sin 3x - \cos^2 \frac{1}{2} x \right) \\ &= \frac{1}{D^3+1} \left( \sin 3x - \frac{1+\cos x}{2} \right) \\ &= \frac{1}{D^3+1} \sin 3x - \frac{1}{2} \frac{1}{D^3+1} \cdot e^{0x} - \frac{1}{2} \frac{1}{D^3+1} \cos x \\ &= \text{P.I.}_1 - \text{P.I.}_2 - \text{P.I.}_3 \end{aligned}$$

$$\begin{aligned} \text{P.I.}_1 &= \frac{1}{D^3+1} \sin 3x \\ &= \frac{1}{D^2 \cdot D+1} \sin 3x && (D^2 \rightarrow -3^2) \\ &= \frac{1}{-9D+1} \sin 3x \\ &= \frac{1}{1-9D} \sin 3x \times \frac{1+9D}{1+9D} \\ &= \frac{(1+9D) \sin 3x}{1-81D^2} && (D^2 \rightarrow -3^2) \\ &= \frac{\sin 3x + 27 \cos 3x}{1-81(-3^2)} \end{aligned}$$

$$\text{P.I.}_1 = \frac{1}{730} (\sin 3x + 27 \cos 3x)$$

$$\begin{aligned} \text{P.I.}_2 &= \frac{1}{2} \frac{e^{0x}}{D^3+1} && (D \rightarrow 0) \\ &= \frac{1}{2} \end{aligned}$$

$$\begin{aligned} \text{P.I.}_3 &= \frac{1}{2} \frac{1}{D^3+1} \cdot \cos x \\ &= \frac{1}{2} \frac{1}{D^2 \cdot D+1} \cos x && (D^2 \rightarrow -1^2) \end{aligned}$$

$$\begin{aligned}
&= \frac{1}{2} \frac{1}{-D+1} \cos x \\
&= \frac{1}{2} \frac{1}{1-D} \cos x \times \frac{1+D}{1+D} \\
&= \frac{1}{2} \left[ \frac{\cos x - \sin x}{1-D^2} \right] \quad (D^2 \rightarrow -1^2) \\
&= \frac{1}{2} \frac{\cos x - \sin x}{2} \\
\text{P.I.}_3 &= \frac{1}{4} (\cos x - \sin x) \\
\text{P.I.} &= \frac{1}{730} (\sin 3x + 27 \cos 3x) - \frac{1}{2} - \frac{1}{4} (\cos x - \sin x).
\end{aligned}$$

7. Solve:  $(D^2 + 4)y = \sin^2 x$ .

**Solution.** The A.E. is

$$\begin{aligned}
m^2 + 4 &= 0 \\
\text{i.e., } m^2 &= -4 \\
m &= \pm 2i \\
\text{C.F.} &= C_1 \cos 2x + C_2 \sin 2x \\
\text{P.I.} &= \frac{1}{D^2 + 4} \sin^2 x
\end{aligned}$$

$$\text{where } \sin^2 x = \frac{1 - \cos 2x}{2}$$

$$\begin{aligned}
&= \frac{1}{D^2 + 4} \left[ \frac{1 - \cos 2x}{2} \right] \\
&= \frac{1}{2} \frac{1}{D^2 + 4} (1 - \cos 2x) \\
&= \frac{1}{2} \left[ \frac{e^{0x}}{D^2 + 4} - \frac{\cos 2x}{D^2 + 4} \right] \\
&= \frac{1}{2} [\text{P.I.}_1 - \text{P.I.}_2] \\
\text{P.I.}_1 &= \frac{e^{0x}}{D^2 + 4} \quad (D \rightarrow 0) \\
&= \frac{1}{4} \\
\text{P.I.}_2 &= \frac{1}{D^2 + 4} \cos 2x \quad (D^2 \rightarrow -2^2) \\
&= \frac{1}{-2^2 + 4} \cos 2x \quad (Dr = 0)
\end{aligned}$$

Differentiate the  $Dx$  and multiplying by 'x'

$$= \frac{1}{2D} x \cos 2x \times \frac{D}{D}$$

$$= \frac{-x \sin 2x \cdot 2}{2 D^2} \quad (D^2 \rightarrow -2^2)$$

$$= \frac{-2x \sin 2x}{2(-2^2)}$$

$$= \frac{2x \sin 2x}{8} = \frac{x \sin 2x}{4}$$

$$\text{P.I.} = \frac{1}{2} \left[ \frac{1}{4} - \frac{x \sin 2x}{4} \right]$$

$$= \frac{1}{8} - \frac{x \sin 2x}{8}$$

$\therefore$  The general solution is

$$y = \text{C.F.} + \text{P.I.}$$

$$y = C_1 \cos 2x + C_2 \sin 2x + \frac{1}{8} - \frac{x}{8} \sin 2x.$$

**8.** Solve  $y'' + 9y = \cos 2x \cdot \cos x$ .

**Solution.** We have

$$(D^2 + 9)y = \cos 2x \cos x$$

A.E. is  $m^2 + 9 = 0$

$$m^2 = -3^2$$

$$m = \pm 3i$$

$$\text{C.F.} = C_1 \cos 3x + C_2 \sin 3x$$

$$\text{P.I.} = \frac{\cos 2x \cdot \cos x}{D^2 + 9}$$

where  $\cos 2x \cdot \cos x = 1/2 (\cos x + \cos 3x)$

$$= \frac{1}{2} \left[ \frac{\cos x + \cos 3x}{D^2 + 9} \right]$$

$$= \frac{1}{2} \frac{\cos x}{D^2 + 9} + \frac{1}{2} \frac{\cos 3x}{D^2 + 9}$$

$$= \text{P.I.}_1 + \text{P.I.}_2$$

$$\text{P.I.}_1 = \frac{1}{2} \frac{\cos x}{D^2 + 9} \quad (D^2 \rightarrow -1^2)$$

$$= \frac{1}{2} \frac{\cos x}{8} = \frac{1}{16} \cos x$$

$$\text{P.I.}_2 = \frac{1}{2} \frac{\cos 3x}{D^2 + 9} \quad (D^2 \rightarrow -3^2)$$

$$= \frac{1}{2} \frac{\cos 3x}{-3^2 + 9} \quad (Dr = 0)$$

Differentiate the  $Dr$  and multiplying by 'x'

$$= \frac{1}{2} \frac{x \cos 3x}{2D} \times \frac{D}{D}$$

$$= \frac{1}{2} \frac{x(-\sin 3x) \cdot 3}{2D^2} \quad (D^2 \rightarrow -3^2)$$

$$= \frac{-3x \sin 3x}{4(-3^2)}$$

$$= \frac{-3x \sin 3x}{-36}$$

$$\text{P.I.}_2 = \frac{x \sin 3x}{12}$$

$$\therefore \text{P.I.} = \frac{1}{16} \cos x + \frac{1}{12} x \sin 3x$$

\(\therefore\) The general solution is

$$y = \text{C.F.} + \text{P.I.}$$

$$= C_1 \cos 3x + C_2 \sin 3x + \frac{1}{16} \cos x + \frac{1}{12} x \sin 3x.$$

## EXERCISE 5.2

Solve the following equations:

1.  $(D^2 + 1)y = \sin 2x.$  [Ans.  $y = C_1 \cos x + C_2 \sin x - \frac{1}{3} \sin 2x$ ]

2.  $(D^2 - 4)y = \sin 2x + \cos 3x.$  [Ans.  $y = C_1 e^{2x} + C_2 e^{-2x} - \frac{1}{8} \sin 2x - \frac{1}{13} \cos 3x$ ]

3.  $(D^2 + 9)y = \sin 3x.$  [Ans.  $y = C_1 \cos 3x + C_2 \sin 3x - \frac{x}{6} \cos 3x$ ]

4.  $(D^2 + 16)y = \cos 4x.$  [Ans.  $y = C_1 \cos 4x + C_2 \sin 4x + \frac{x}{8} \sin 4x$ ]

5.  $(D^2 + 1)y = \sin x \sin 2x.$  [Ans.  $y = C_1 \cos x + C_2 \sin x + \frac{1}{16} (4x \sin x + \cos 3x)$ ]

6.  $(D^2 - 2D - 8)y = 4 \cos 2x$ .  $\left[ \text{Ans. } y = C_1 e^{4x} + C_2 e^{-2x} - \frac{1}{10} (3 \cos 2x + \sin 2x) \right]$
7.  $(D^2 + 5D + 6)y = \sin x + e^{-2x}$ .  $\left[ \text{Ans. } y = C_1 e^{-3x} + C_2 e^{-2x} + x e^{-2x} - \frac{1}{10} (\cos x - \sin x) \right]$
8.  $(D^2 + 3D + 2)y = 4 \cos^2 x$ .  $\left[ \text{Ans. } y = C_1 e^{-x} + C_2 e^{-2x} + 1 + \frac{1}{10} (3 \sin 2x - \cos 2x) \right]$
9.  $(D^2 - 4)y = \cos x \cos 2x$ .  $\left[ \text{Ans. } y = C_1 e^{2x} + C_2 e^{-2x} - \frac{1}{2} \left( \frac{1}{13} \cos 3x + \frac{1}{5} \cos x \right) \right]$
10.  $(D^2 - 4D + 4)y = \sin 2x + \cos 2x$ .  $\left[ \text{Ans. } y = (C_1 + C_2 x)e^{2x} + \frac{1}{8} (\cos 2x - \sin 2x) \right]$
11.  $(D^2 + 8D + 25)y = 48 \cos x - 16 \sin x$ .  $\left[ \text{Ans. } y = e^{-4x} (C_1 \cos 3x + C_2 \sin 3x) + 2 \cos x \right]$
12.  $(D^3 + D^2 + D + 1)y = \sin 3x$ .  $\left[ \text{Ans. } y = C_1 e^{-x} + C_2 \cos x + C_3 \sin x + \frac{1}{80} (3 \cos 3x - \sin 3x) \right]$
13.  $(D^4 - 2D^2 + 1)y = \cos x$ .  $\left[ \text{Ans. } y = (C_1 + C_2 x)e^x + (C_3 + C_4 x)e^{-x} + \frac{1}{4} \cos x \right]$
14.  $(D^3 + 8)y = \sin 2x$ .  $\left[ \text{Ans. } y = C_1 e^{-2x} + e^x (C_2 \cos \sqrt{3}x + C_3 \sin \sqrt{3}x) + \frac{1}{16} (\cos 2x + \sin 2x) \right]$
15.  $(D^4 - 16)y = \sin x \cos x$ .  $\left[ \text{Ans. } y = C_1 e^{2x} + C_2 e^{-2x} + C_3 \cos 2x + C_4 \sin 2x + \frac{1}{64} x \cos 2x \right]$
16.  $(D - 1)^3 y = \cos^2 x$ .  $\left[ \text{Ans. } y = (C_1 + C_2 x + C_3 x^2)e^x - \frac{1}{2} - \frac{1}{250} (2 \sin 2x - 11 \cos 2x) \right]$
17.  $(D^3 - 3D + 2)y = \sin 2x$ .  $\left[ \text{Ans. } y = (C_1 + C_2 x)e^x + C_3 e^{-2x} + \frac{1}{100} (7 \cos 2x + \sin 2x) \right]$
18.  $(D^2 + 1)(D^2 + 4)y = \cos 2x + \sin x$ .  $\left[ \text{Ans. } y = C_1 \cos x + C_2 \sin x + C_3 \cos 2x + C_4 \sin 2x - \frac{1}{12} x \sin 2x - \frac{1}{6} x \cos x \right]$
19.  $\frac{d^3 y}{dx^3} + y = 65 \cos (2x + 1) + e^{-x}$ .  $\left[ \text{Ans. } y = C_1 e^{-x} + e^{\frac{x}{2}} \left\{ C_2 \cos \frac{\sqrt{3}}{2} x + C_3 \sin \frac{\sqrt{3}}{2} x \right\} + \cos (2x + 1) - 8 \sin (2x + 1) + \frac{1}{3} x e^{-x} \right]$

**Type 3**

1. Solve  $y'' + 3y' + 2y = 12x^2$ .

**Solution.** We have  $(D^2 + 3D + 2)y = 12x^2$

A.E. is  $m^2 + 3m + 2 = 0$

i.e.,  $(m + 1)(m + 2) = 0$

$\Rightarrow m = -1, -2$

C.F. =  $C_1e^{-x} + C_2e^{-2x}$

P.I. =  $\frac{12x^2}{D^2 + 3D + 2}$

We need to divide for obtaining the P.I.

$$\begin{array}{r}
 6x^2 - 18x + 21 \\
 \hline
 2 + 3D + D^2 \left| \begin{array}{l} 12x^2 \\ 12x^2 + 36x + 12 \\ \hline -36x - 12 \\ -36x - 54 \\ \hline 42 \\ 42 \\ \hline 0 \end{array} \right.
 \end{array}$$

**Note:**

$$3D(6x^2) = 36x$$

$$D^2(6x^2) = 12$$

Hence, P.I. =  $6x^2 - 18x + 21$

$\therefore$  The general solution is

$$y = \text{C.F.} + \text{P.I.}$$

$$y = C_1e^{-x} + C_2e^{-2x} + 6x^2 - 18x + 21.$$

2. Solve  $\frac{d^2y}{dx^2} + 2\frac{dy}{dx} + y = 2x + x^2$ .

**Solution.** We have  $(D^2 + 2D + 1)y = 2x + x^2$

A.E. is  $m^2 + 2m + 1 = 0$

i.e.,  $(m + 1)^2 = 0$

i.e.,  $(m + 1)(m + 1) = 0$

$\Rightarrow m = -1, -1$

C.F. =  $(C_1 + C_2x)e^{-x}$

P.I. =  $\frac{2x + x^2}{D^2 + 2D + 1} = \frac{x^2 + 2x}{1 + 2D + D^2}$

$$\begin{array}{r}
 1 + 2D + D^2 \quad \begin{array}{l} x^2 - 2x + 2 \\ \hline x^2 + 2x \\ x^2 + 4x + 2 \\ \hline -2x - 2 \\ -2x - 4 \\ \hline 2 \\ 2 \\ \hline 0 \end{array}
 \end{array}$$

$$\begin{aligned}
 \therefore \quad \text{P.I.} &= x^2 - 2x + 2 \\
 \therefore \quad y &= \text{C.F.} + \text{P.I.} \\
 &= (C_1 + C_2 x) e^{-x} + (x^2 - 2x + 2).
 \end{aligned}$$

3. Solve  $\frac{d^2 y}{dx^2} + 5 \frac{dy}{dx} + 6y = x^2$ .

**Solution.** We have

$$(D^2 + 5D + 6)y = x^2$$

A.E. is  $m^2 + 5m + 6 = 0$

$$(m + 2)(m + 3) = 0$$

i.e.,  $m = -2, -3$

$$\text{C.F.} = C_1 e^{-2x} + C_2 e^{-3x}$$

$$\text{P.I.} = \frac{x^2}{D^2 + 5D + 6} = \frac{x^2}{6 + 5D + D^2}$$

P.I. is found by division method

$$\begin{array}{r}
 \frac{x^2}{6} - \frac{5x}{18} + \frac{19}{108} \\
 6 + 5D + D^2 \quad \begin{array}{l} x^2 \\ \hline x^2 + \frac{5x}{3} + \frac{1}{3} \\ \hline -\frac{5x}{3} - \frac{1}{3} \\ -\frac{5x}{3} - \frac{25}{18} \\ \hline \frac{19}{18} \\ \frac{19}{18} \\ \hline 0 \end{array}
 \end{array}$$

$$5D \left( \frac{x^2}{6} \right) = \frac{5x}{3}$$

$$D^2 \left( \frac{x^2}{6} \right) = \frac{1}{3}$$

$$5D \left( \frac{-5x}{18} \right) = \frac{-25}{18}$$



$$\begin{aligned} \therefore \text{P.I.} &= \frac{x^2}{6} - \frac{5x}{18} + \frac{19}{108} \\ &= \frac{1}{108} (18x^2 - 30x + 19) \end{aligned}$$

$$\begin{aligned} \therefore y &= \text{C.F.} + \text{P.I.} \\ &= C_1 e^{-2x} + C_2 e^{-3x} + \frac{1}{108} (18x^2 - 30x + 19). \end{aligned}$$

4. Solve  $(D^3 + 2D^2 + D) y = x^3$ .

**Solution.** A.E. is

$$m^3 + 2m^2 + m = 0$$

$$\text{i.e., } m(m^2 + 2m + 1) = 0$$

$$\text{i.e., } m(m+1)^2 = 0$$

$$\Rightarrow m = 0, -1, -1$$

$$\text{C.F.} = C_1 + (C_2 + C_3 x) e^{-x}$$

$$\text{P.I.} = \frac{x^3}{D^3 + 2D^2 + D} = \frac{x^3}{D + 2D^2 + D^3}$$

$D + 2D^2 + D^3$	$x^3$	$x^4/4 - 2x^3 + 9x^2 - 24x$	<b>Note:</b> $\frac{x^3}{D} = \int x^3 dx = \frac{x^4}{4}$
	$x^3 + 6x^2 + 6x$	$x^3 + 6x^2 + 6x$	$2D^2 \left( \frac{x^4}{4} \right) = 6x^2$
	$-6x^2 - 6x$	$-6x^2 - 6x$	$D^3 \left( \frac{x^4}{4} \right) = 6x$
	$-6x^2 - 24x - 12$	$-6x^2 - 24x - 12$	$\frac{-6x^2}{D} = \int -6x^2 dx = -2x^3$
	$18x + 12$	$18x + 12$	$\frac{18x}{D} = \int 18x dx = 9x^2$
	$18x + 36$	$18x + 36$	$\frac{-24}{D} = \int (-24) dx = -24x$
	$-24$	$-24$	
	$-24$	$-24$	
	$0$	$0$	

$$\therefore \text{P.I.} = \frac{x^4}{4} - 2x^3 + 9x^2 - 24x$$

$$\therefore y = \text{C.F.} + \text{P.I.}$$

$$= C_1 + (C_2 + C_3 x) e^{-x} + \frac{x^4}{4} - 2x^3 + 9x^2 - 24x.$$

### EXERCISE 5.3

Solve the following equations:

1.  $(D^2 - 9)y = 2x - 1$ .  $\left[ \text{Ans. } y = C_1 e^{3x} + C_2 e^{-3x} - \frac{1}{9}(2x - 1) \right]$

2.  $(D^2 + 4)y = x^2 - x$ .  $\left[ \text{Ans. } y = C_1 \cos 2x + C_2 \sin 2x + \frac{1}{8}(2x^2 - 2x - 1) \right]$

3.  $(D^2 - 4D + 4)y = x^2$ .  $\left[ \text{Ans. } y = (C_1 + C_2 x)e^{2x} + \frac{1}{8}(2x^2 + 4x + 3) \right]$

4.  $(D^2 + D - 6)y = x$ .  $\left[ \text{Ans. } y = C_1 e^{2x} + C_2 e^{-3x} - \frac{1}{36}(6x + 1) \right]$

5.  $(D^2 + 2D + 1)y = x^2 + 2x$ .  $\left[ \text{Ans. } y = (C_1 + C_2 x)e^{-x} + x^2 - 2x + 2 \right]$

6.  $(D^2 - 2D + 3)y = x^2$ .  $\left[ \text{Ans. } y = e^x \left( C_1 \cos \sqrt{2}x + C_2 \sin \sqrt{2}x \right) + \frac{1}{27}(9x^2 + 12x + 2) \right]$

7.  $(D^2 - 5D + 6)y = x^2 + x - 2$ .  $\left[ \text{Ans. } y = C_1 e^{2x} + C_2 e^{3x} + \frac{1}{54}(9x^2 + 24x - 1) \right]$

8.  $(D^3 + 1)y = x^3$ .  $\left[ \text{Ans. } y = C_1 e^{-x} + e^{x/2} \left( C_2 \cos \frac{\sqrt{3}}{2}x + C_3 \sin \frac{\sqrt{3}}{2}x \right) + x^3 - 6 \right]$

9.  $(D^3 - D^2)y = x^2 - 3x + 1$ .  $\left[ \text{Ans. } y = C_1 + C_2 x + C_3 e^x - \frac{x^3}{12}(x - 2) \right]$

10.  $(D^3 + 8)y = x^4 + 2x + 1$ .  $\left[ \text{Ans. } y = C_1 e^{-2x} + e^x \left( C_2 \cos \sqrt{3}x + C_3 \sin \sqrt{3}x \right) + \frac{1}{8}(x^4 - x + 1) \right]$

#### Type 4

1. Solve  $\frac{d^2 y}{dx^2} + 2 \frac{dy}{dx} - 3y = e^x \cos x$ .

**Solution.** We have

$$(D^2 + 2D - 3)y = e^x \cos x$$

A.E. is  $m^2 + 2m - 3 = 0$

i.e.,  $(m + 3)(m - 1) = 0$

i.e.,  $m = -3, 1$

$$\text{C.F.} = C_1 e^{-3x} + C_2 e^x$$

$$\text{P.I.} = \frac{1}{D^2 + 2D - 3} e^x \cos x$$

Taking  $e^x$  outside the operator and changing  $D$  to  $D + 1$

$$\begin{aligned}
&= e^x \frac{1}{(D+1)^2 + 2(D+1) - 3} \cos x \\
&= e^x \frac{1}{D^2 + 4D} \cos x && (D^2 \rightarrow -1^2) \\
&= e^x \frac{1}{-1 + 4D} \cos x \\
&= e^x \left[ \frac{\cos x}{4D-1} \times \frac{4D+1}{4D+1} \right] \\
&= e^x \left[ \frac{-4 \sin x + \cos x}{16D^2 - 1} \right] && (D^2 \rightarrow -1^2) \\
&= e^x \left[ \frac{-4 \sin x + \cos x}{-17} \right] \\
&= \frac{e^x}{17} (4 \sin x - \cos x)
\end{aligned}$$

$$\therefore y = \text{C.F.} + \text{P.I.}$$

$$y = C_1 e^{-3x} + C_2 e^x + \frac{e^x}{17} (4 \sin x - \cos x).$$

2. Solve  $(D^3 + 1)y = 5e^x x^2$ .

**Solution.** A.E. is

$$m^3 + 1 = 0$$

$$\text{i.e., } (m + 1)(m^2 - m + 1) = 0$$

$$(m + 1) = 0, m^2 - m + 1 = 0$$

$$m = -1$$

$$m = \frac{1 \pm \sqrt{3}i}{2}$$

$$\text{C.F.} = C_1 e^{-x} + e^{\frac{x}{2}} \left( C_2 \cos \frac{\sqrt{3}}{2}x + C_3 \sin \frac{\sqrt{3}}{2}x \right)$$

$$\text{P.I.} = \frac{1}{D^3 + 1} 5e^x x^2$$

Taking  $e^x$  outside the operator and changing  $D$  to  $D + 1$

$$\begin{aligned}
&= e^x \frac{1}{(D+1)^3 + 1} \cdot 5x^2 \\
&= e^x \frac{5x^2}{D^3 + 3D^2 + 3D + 2}
\end{aligned}$$

$$= \frac{5e^x}{2} \left[ \frac{2x^2}{2 + 3D + 3D^2 + D^3} \right]$$

(For a convenient division we have multiplied and divided by 2)

$$\begin{array}{r|l}
 & x^2 - 3x + \frac{3}{2} \\
 2 + 3D + 3D^2 + D^3 & \begin{array}{l} 2x^2 \\ 2x^2 + 6x + 6 \\ \hline -6x - 6 \\ -6x - 9 \\ \hline 3 \\ 3 \\ \hline 0 \end{array}
 \end{array}$$

$$\begin{aligned}
 \therefore \text{P.I.} &= \left( x^2 - 3x + \frac{3}{2} \right) \cdot \frac{5e^x}{2} \\
 &= \frac{5e^x}{4} (2x^2 - 6x + 3) \\
 y &= \text{C.F.} + \text{P.I.} \\
 &= C_1 e^{-x} + e^{\frac{x}{2}} \left\{ C_2 \cos \frac{\sqrt{3}}{2} x + C_3 \sin \frac{\sqrt{3}}{2} x \right\} + \frac{5e^x}{4} (2x^2 - 6x + 3).
 \end{aligned}$$

3. Solve  $(D^2 - 4D + 3)y = e^{2x} \sin 3x$ .

**Solution.** A.E. is

$$m^2 - 4m + 3 = 0$$

$$\text{i.e., } (m - 1)(m - 3) = 0$$

$$m = 1, 3$$

$$\text{C.F.} = C_1 e^x + C_2 e^{3x}$$

$$\text{P.I.} = \frac{1}{D^2 - 4D + 3} e^{2x} \sin 3x$$

Taking  $e^{2x}$  outside the operator and changing  $D$  to  $D + 2$

$$\begin{aligned}
 &= e^{2x} \frac{1}{(D + 2)^2 - 4(D + 2) + 3} \cdot \sin 3x \\
 &= e^{2x} \left[ \frac{1}{D^2 - 1} \right] \sin 3x \quad (D^2 \rightarrow -3^2) \\
 &= -\frac{1}{10} e^{2x} \sin 3x
 \end{aligned}$$

$$y = \text{C.F.} + \text{P.I.}$$

$$= C_1 e^x + C_2 e^{3x} - \frac{1}{10} e^{2x} \sin 3x.$$

4. Solve  $\frac{d^2y}{dx^2} + 4y = 2e^x \sin^2 x$ .

**Solution.** We have

$$(D^2 + 4)y = 2e^x \sin^2 x$$

A.E. is  $m^2 + 4 = 0$

i.e.,  $m^2 = -4$

$$m = \pm 2i$$

$$\text{C.F.} = C_1 \cos 2x + C_2 \sin 2x$$

$$\text{P.I.} = \frac{1}{D^2 + 4} 2e^x \sin^2 x$$

where  $\sin^2 x = \frac{1 - \cos 2x}{2}$

$$= \frac{1}{D^2 + 4} e^x (1 - \cos 2x)$$

$$= \frac{1}{D^2 + 4} (e^x - e^x \cos 2x)$$

$$= \frac{e^x}{D^2 + 4} - \frac{e^x \cos 2x}{D^2 + 4}$$

$$= \text{P.I.}_1 - \text{P.I.}_2$$

$$\text{P.I.}_1 = \frac{1}{D^2 + 4} e^x \quad (D \rightarrow 1)$$

$$= \frac{e^x}{5}$$

$$\text{P.I.}_2 = \frac{e^x \cos 2x}{D^2 + 4}$$

Taking  $e^x$  outside the operator and changing  $D$  to  $D + 1$

$$= e^x \frac{1}{(D+1)^2 + 4} \cos 2x$$

$$= e^x \left[ \frac{1}{D^2 + 2D + 1 + 4} \right] \cos 2x$$

$$= e^x \left[ \frac{1}{D^2 + 2D + 5} \right] \cos 2x \quad (D^2 \rightarrow -2^2)$$

$$= e^x \frac{1}{-2^2 + 2D + 5} \cos 2x$$

$$= e^x \cdot \frac{1}{2D + 1} \cos 2x \times \frac{2D - 1}{2D - 1}$$

$$= e^x \left[ \frac{-4 \sin 2x - \cos 2x}{4D^2 - 1} \right] \quad (D^2 \rightarrow -2^2)$$

$$= e^x \left[ \frac{-4 \sin 2x - \cos 2x}{-17} \right]$$

$$= \frac{e^x}{17} (4 \sin 2x + \cos 2x)$$

$$\therefore y = \text{C.F.} + \text{P.I.}$$

$$y = C_1 \cos 2x + C_2 \sin 2x + \frac{e^x}{17} (4 \sin 2x + \cos 2x).$$

5. Solve  $(D^2 - 4D + 3)y = 2x e^{3x}$ .

**Solution.** A.E. is

$$m^2 - 4m + 3 = 0$$

$$\text{i.e.,} \quad (m - 1)(m - 3) = 0$$

$$\text{i.e.,} \quad m = 1, 3$$

$$\text{C.F.} = C_1 e^x + C_2 e^{3x}$$

$$\text{P.I.} = \frac{1}{D^2 - 4D + 3} 2x e^{3x}$$

Taking  $e^{3x}$  outside the operator and changing  $D \rightarrow D + 3$

$$= e^{3x} \cdot \frac{2x}{(D+3)^2 - 4(D+3) + 3}$$

$$= e^{3x} \left[ \frac{2x}{D^2 + 2D} \right]$$

By division method

$$2D + D^2 \overline{\begin{array}{r} x^2/2 - x/2 \\ 2x \\ 2x + 1 \\ \hline -1 \\ -1 \\ \hline 0 \end{array}}$$

$$\text{Note:} \quad \frac{2x}{2D} = \int x dx = \frac{x^2}{2}$$

$$\frac{-1}{2D} = \int \frac{-1}{2} dx = -\frac{x}{2}$$

$$\text{P.I.} = e^{3x} \left( \frac{x^2}{2} - \frac{x}{2} \right)$$

$$y = \text{C.F.} + \text{P.I.}$$

$$= C_1 e^x + C_2 e^{3x} + e^{3x} \left( \frac{x^2}{2} - \frac{x}{2} \right).$$

**Type 5**

1. Solve  $\frac{d^2y}{dx^2} + 4y = x \sin x$ .

**Solution.** We have

$$(D^2 + 4)y = x \sin x$$

A.E. is

$$m^2 + 4 = 0$$

$$m^2 = -4$$

$$m = \pm 2i$$

$$\text{C.F.} = C_1 \cos 2x + C_2 \sin 2x$$

$$\text{P.I.} = \frac{1}{D^2 + 4} x \sin x$$

Let us use

$$\frac{xV}{f(D)} = \left[ x - \frac{f'(D)}{f(D)} \right] \frac{V}{f(D)}$$

$$\frac{x \sin x}{D^2 + 4} = \left[ x - \frac{2D}{D^2 + 4} \right] \frac{\sin x}{D^2 + 4} \quad (D^2 \rightarrow -1^2)$$

$$= \frac{x \sin x}{D^2 + 4} - \frac{2D(\sin x)}{(D^2 + 4)^2} \quad (D^2 \rightarrow -1^2)$$

$$= \frac{x \sin x}{3} - \frac{2 \cos x}{3^2}$$

$$= \frac{x \sin x}{3} - \frac{2 \cos x}{9}$$

$$\text{P.I.} = \frac{1}{9} (3x \sin x - 2 \cos x)$$

$$y = \text{C.F.} + \text{P.I.}$$

$$= C_1 \cos 2x + C_2 \sin 2x + \frac{1}{9} (3x \sin x - 2 \cos x).$$

2. Solve  $(D^2 + 2D + 1)y = x \cos x$ .

**Solution.** A.E. is

$$m^2 + 2m + 1 = 0$$

i.e.,

$$(m + 1)^2 = 0$$

$$m = -1, -1$$

$$\text{C.F.} = (C_1 + C_2 x) e^{-x}$$

$$\text{P.I.} = \frac{x \cos x}{D^2 + 2D + 1}.$$

Let us we have

$$\begin{aligned} \frac{xV}{f(D)} &= \left[ x - \frac{f'(D)}{f(D)} \right] \cdot \frac{V}{f(D)} \\ &= \left[ x - \frac{2D+2}{D^2+2D+1} \right] \cdot \frac{\cos x}{D^2+2D+1} \\ &= \frac{x \cos x}{D^2+2D+1} - \frac{(2D+2) \cos x}{(D^2+2D+1)^2} \\ &= \text{P.I.}_1 - \text{P.I.}_2 \\ \text{P.I.}_1 &= \frac{x \cos x}{D^2+2D+1} \quad (D^2 \rightarrow -1^2) \\ &= \frac{x \cos x \times D}{2D \times D} \\ &= \frac{-x \sin x}{2D^2} \quad (D^2 \rightarrow -1^2) \\ \text{P.I.}_1 &= \frac{x}{2} \sin x \\ \text{P.I.}_2 &= \frac{(2D+2) \cos x}{(D^2+2D+1)^2} \quad (D^2 \rightarrow -1^2) \\ &= \frac{-2 \sin x + 2 \cos x}{(2D)^2} \\ &= \frac{-2 \sin x + 2 \cos x}{4D^2} \quad (D^2 = -1^2) \\ &= \frac{2 \sin x - 2 \cos x}{4} \\ &= \frac{1}{2} (\sin x - \cos x) \\ \text{P.I.} &= \frac{1}{2} x \sin x - \frac{1}{2} (\sin x - \cos x) \\ &= \frac{1}{2} (x \sin x - \sin x + \cos x) \\ y &= \text{C.F.} + \text{P.I.} \\ y &= (C_1 + C_2 x) e^{-x} + \frac{1}{2} (x \sin x - \sin x + \cos x). \end{aligned}$$



3. Solve  $\frac{d^2y}{dx^2} - y = x e^x \sin x$ .

**Solution.** We have the equation  $(D^2 - 1)y = x e^x \sin x$

A.E. is  $m^2 - 1 = 0$

$$m^2 = 1$$

$$m = +1, -1$$

$$\text{C.F.} = C_1 e^x + C_2 e^{-x}$$

$$\text{P.I.} = \frac{1}{D^2 - 1} x e^x \sin x$$

Taking  $e^x$  outside the operator and changing  $D \rightarrow D + 1$

$$= e^x \frac{1}{(D+1)^2 - 1} x \sin x$$

$$= e^x \left[ \frac{x \sin x}{D^2 + 2D} \right]$$

Let us use  $\frac{xV}{f(D)} = \left[ x - \frac{f'(D)}{f(D)} \right] \frac{V}{f(D)}$

$$= e^x \left[ x - \frac{2D+2}{D^2+2D} \right] \cdot \frac{\sin x}{D^2+2D} \quad (D^2 \rightarrow -1^2)$$

$$= e^x \left\{ \frac{x \sin x}{2D-1} - \frac{2(D+1)}{D^2(D+2)^2} \sin x \right\}$$

$$= e^x \left\{ \frac{x(2D+1) \sin x}{4D^2-1} - \frac{2(D+1)}{-1(D^2+4D+4)} \sin x \right\}$$

$$= e^x \left\{ \frac{2x \cos x + x \sin x}{-5} + \frac{2(D+1)(4D-3)}{16D^2-9} \sin x \right\}$$

$$= e^x \left\{ \frac{-1}{5} x (2 \cos x + \sin x) - \frac{2}{25} (4D^2 + D - 3) \sin x \right\}$$

$$= e^x \left\{ \frac{-1}{5} x \left( 2 \cos x + \sin x - \frac{2}{25} (-4 \sin x + \cos x - 3 \sin x) \right) \right\}$$

$$\text{P.I.} = \frac{-1}{25} e^x \{ (5x - 14) \sin x + 2(5x + 1) \cos x \}$$

$\therefore$  The general solution is

$$y = \text{C.F.} + \text{P.I.}$$

$$= C_1 e^x + C_2 e^{-x} - \frac{1}{25} e^x \{ (5x - 14) \sin x + 2(5x + 1) \cos x \}.$$

4. Solve  $\frac{d^2y}{dx^2} - 4\frac{dy}{dx} + 4y = 3x^2 e^{2x} \sin 2x$ .

**Solution.** We have

$$(D^2 - 4D + 4)y = 3x^2 e^{2x} \sin 2x$$

A.E. is  $m^2 - 4m + 4 = 0$

i.e.,  $(m - 2)^2 = 0$

$$m = 2, 2$$

$$\text{C.F.} = (C_1 + C_2 x) e^{2x}$$

$$\text{P.I.} = \frac{1}{(D-2)^2} \cdot 3x^2 e^{2x} \sin 2x$$

Taking  $e^{2x}$  outside the operator and changing  $D$  to  $D + 2$

$$= 3e^{2x} \frac{1}{D^2} x^2 \sin 2x$$

We shall find  $\frac{1}{D^2} x^2 \sin 2x$  Integrating twice

$$\frac{1}{D} (x^2 \sin 2x) = \int x^2 \sin 2x dx$$

Applying Integration by parts

$$\begin{aligned} &= x^2 \left( \frac{-\cos 2x}{2} \right) - 2x \left( \frac{-\sin 2x}{4} \right) + 2 \left( \frac{\cos 2x}{8} \right) \\ &= \frac{-x^2 \cos 2x}{2} + \frac{x \sin 2x}{2} + \frac{\cos 2x}{4} \end{aligned}$$

Hence,  $\frac{1}{D^2} (x^2 \sin 2x) = \frac{-1}{2} \int x^2 \cos 2x dx + \frac{1}{2} \int x \sin 2x dx + \frac{1}{4} \int \cos 2x dx$

$$= \frac{-1}{2} \left[ x^2 \frac{\sin 2x}{2} - 2x \left( \frac{-\cos 2x}{4} \right) + 2 \left( \frac{-\sin 2x}{8} \right) \right]$$

$$+ \frac{1}{2} \left[ x \left( \frac{-\cos 2x}{2} \right) - 1 \left( \frac{-\sin 2x}{4} \right) \right] + \frac{1}{4} \cdot \frac{\sin 2x}{2}$$

$$= \frac{-1}{8} (2x^2 \sin 2x + 4x \cos 2x - 3 \sin 2x)$$

$\therefore$  P.I. =  $\frac{-3}{8} e^{2x} (2x^2 \sin 2x + 4x \cos 2x - 3 \sin 2x)$

$\therefore$  The general solution is

$$y = \text{C.F.} + \text{P.I.}$$

$$= (C_1 + C_2 x) e^{2x} - \frac{3}{8} e^{2x} (2x^2 \sin 2x + 4x \cos 2x - 3 \sin 2x).$$

5. Solve  $\frac{d^2 y}{dx^2} - 2 \frac{dy}{dx} + y = x e^x \sin x$ .

**Solution.** We have

$$(D^2 - 2D + 1)y = x e^x \sin x$$

A.E. is  $m^2 - 2m + 1 = 0$

i.e.,  $(m - 1)^2 = 0$

$$m = 1, 1$$

$$\text{C.F.} = (C_1 + C_2 x) e^x$$

$$\text{P.I.} = \frac{1}{D^2 - 2D + 1} x e^x \sin x$$

$$= \frac{1}{(D-1)^2} x e^x \sin x \quad (D \rightarrow D+1)$$

$$= e^x \frac{1}{D^2} x \sin x$$

Now  $\frac{1}{D^2} (x \sin x) = \frac{1}{D} \cdot \int x \sin x \, dx$

Since  $\frac{1}{D}$  is the Integration

$$= \frac{1}{D} [x(-\cos x) - 1(-\sin x)]$$

On integration by parts

$$= \frac{1}{D} (-x \cos x + \sin x)$$

$$= -\int x \cos x \, dx + \int \sin x \, dx$$

$$= -\{x \sin x - 1(-\cos x)\} - \cos x$$

$$= -x \sin x - 2 \cos x$$

$$= -(x \sin x + 2 \cos x)$$

Hence  $\text{P.I.} = -e^x (x \sin x + 2 \cos x)$ .

$\therefore$  The complete solution is

$$y = \text{C.F.} + \text{P.I.}$$

$$= (C_1 + C_2 x) e^x - e^x (x \sin x + 2 \cos x).$$

**EXERCISE 5.4**

Solve the following equations:

$$1. (D^2 + 9)y = x \cos x. \quad \left[ \text{Ans. } y = C_1 \cos 3x + C_2 \sin 3x + \frac{1}{32} (4x \cos x + \sin x) \right]$$

$$2. (D^2 - 2D + 1)y = x \sin x. \quad \left[ \text{Ans. } y = (C_1 + C_2 x) e^{-x} + \frac{1}{2} (\sin x + \cos x - 1) \right]$$

$$3. (D^2 - 1)y = x \sin 3x. \quad \left[ \text{Ans. } y = C_1 e^x + C_2 e^{-x} - \frac{1}{50} (5x \sin 3x + 3 \cos 3x) \right]$$

$$4. (D^2 - 3D + 2)y = x \cos 2x. \quad \left[ \text{Ans. } y = C_1 e^x + C_2 e^{2x} - \frac{1}{20} x (3 \sin 2x + \cos 2x) - \frac{1}{200} (7 \sin 2x + 24 \cos 2x) \right]$$

$$5. \frac{d^2 y}{dx^2} + a^2 y = x \cos ax. \quad \left[ \text{Ans. } y = C_1 \cos ax + C_2 \sin ax + \frac{1}{4a^2} (ax^2 \sin ax + x \cos ax) \right]$$

$$6. \frac{d^2 y}{dx^2} - y = x^2 \cos x. \quad \left[ \text{Ans. } y = C_1 e^x + C_2 e^{-x} - \frac{1}{2} [(x^2 - 1) \cos x - 2x \sin x] \right]$$

$$7. (D^2 - 4D + 4)y = 4x^2 e^{2x} \cos 2x. \quad \left[ \text{Ans. } y = (C_1 + C_2 x) e^{2x} - \frac{1}{2} e^{2x} [(2x^2 - 3) \cos 2x - 4x \sin 2x] \right]$$

$$8. \frac{d^4 y}{dx^4} - y = x \sin x. \quad \left[ \text{Ans. } y = C_1 \cos x + C_2 \sin x + C_3 e^x + C_4 e^{-x} + \frac{1}{8} [(x^2 + 2) \cos 5x - 3x \sin x] \right]$$

**5.6 METHOD OF UNDETERMINED COEFFICIENTS**

Here we consider a method of finding the particular integral of the equation  $f(D)y = \phi(x)$ . When  $\phi(x)$  is of some special forms. In this method first we assume that the particular integral is of certain form with some coefficients. Then substituting the value of this particular integral in the given equation and comparing the coefficients, we get the value of these “undetermined” coefficients. Therefore, the particular integral can be obtained. This method is applicable only when the equation is with constant coefficients.

In the following cases we give the forms of the particular integral corresponding to a special form of  $\phi(x)$ .

**Case (i):** If  $\phi(x)$  is polynomial of degree  $n$

$$\text{i.e.,} \quad \phi(x) = a_0 + a_1 x + \dots + a_n x^n$$

Then particular integral is of the form

$$y_p = a_0 + a_1 x + a_2 x^2 + \dots + a_n x^n$$

**Example:**  $\phi(x) = 3x^2$   
 $y_p = a + bx + cx^2$

**Case (ii):** If  $\phi(x) = e^{mx}$  then the particular integral is  $y_p = a e^{mx}$

**Example:**  $5e^x$  is the  $\phi(x)$

$\therefore \phi(x) = 5e^x$

$\therefore$  Particular Integral  $y_p = a e^x$ .

**Case (iii):** If  $\phi(x) = \sin ax$  or  $\cos ax$  or  $p \sin ax + q \cos ax$  then P.I. is of the form  $y_p = A \cos ax + B \sin ax$

**Example 1:**  $\phi(x) = 2 \sin 5x$

$\therefore y_p = a \cos 5x + b \sin 5x$

**Example 2:**  $\phi(x) = 3 \cos 2x$

$\therefore y_p = a \cos 2x + b \sin 2x$

**Case (iv):** If  $\phi(x) = e^{mx} \sin bx$

or

$\phi(x) = e^{mx} \cos bx$

or

$\phi(x) = e^{mx} (a \sin bx + b \cos bx)$  then

Particular Integral of the form

$y_p = e^{mx} (a \sin bx + b \cos bx)$

**Example:**  $\phi(x) = 2e^{2x} \cos 3x$

$y_p = e^{2x} (a \cos 3x + b \sin 3x)$ .

## WORKED OUT EXAMPLES

1. Solve by the method of undetermined coefficients,

$$y'' - 3y' + 2y = x^2 + x + 1.$$

**Solution.** For the given equation is  $(D^2 - 3D + 2)y = x^2 + x + 1$

A.E. is  $m^2 - 3m + 2 = 0$

i.e.,  $(m - 1)(m - 2) = 0$

$m = 1, 2$

C.F. =  $C_1 e^x + C_2 e^{2x}$

Here  $\phi(x) = x^2 + x + 1$  and 0 is not a root of the A.E.

We assume for P.I. in the form

$$y_p = a + bx + cx^2 \quad \dots(1)$$

We have to find  $a, b$  and  $c$  such that

$$y''_p - 3y'_p + 2y_p = x^2 + x + 1 \quad \dots(2)$$

$$\begin{aligned} \text{From Eqn. (1)} \quad y'_p &= b + 2cx \\ y''_p &= 2c \end{aligned}$$

Now Eqn. (2) becomes

$$\begin{aligned} 2c - 3(b + 2cx) + 2(a + bx + cx^2) &= x^2 + x + 1 \\ (2c - 3b + 2a) + (-6c + 2b)x + (2c)x^2 &= x^2 + x + 1 \end{aligned}$$

Equating the coefficients

$$2c - 3b + 2a = 1 \quad \dots(3)$$

$$-6c + 2b = 1 \quad \dots(4)$$

$$2c = 1 \quad \dots(5)$$

$$\text{Eqn. (5)} \Rightarrow c = \frac{1}{2}$$

$$\begin{aligned} \text{Eqn. (4)} \Rightarrow \frac{-6}{2} + 2b &= 1 \\ 2b &= 1 + 3 \\ b &= 2 \end{aligned}$$

$$\begin{aligned} \text{Eqn. (3)} \Rightarrow \frac{2}{2} - 3 \times 2 + 2a &= 1 \\ 2a &= 1 - 1 + 6 \\ a &= 3 \end{aligned}$$

Eqn. (1) becomes

$$\text{P.I.} = y_p = 3 + 2x + \frac{1}{2}x^2$$

$\therefore$  The general solution is

$$y = \text{C.F.} + \text{P.I.}$$

$$y = C_1 e^x + C_2 e^{2x} + \left(3 + 2x + \frac{1}{2}x^2\right).$$

**2. Solve by the method of undetermined coefficients**

$$y'' - 2y' + 5y = e^{2x}.$$

**Solution.** We have

$$(D^2 - 2D + 5)y = e^{2x}$$

$$\text{A.E. is } m^2 - 2m + 5 = 0$$

$$m = 1 \pm 2i$$

$$\text{C.F.} = e^x (C_1 \cos 2x + C_2 \sin 2x)$$

Here  $\phi(x) = e^{2x}$  and 2 is not a root of the A.E.

$$\text{We assume for P.I. in the form } y_p = ae^{2x} \quad \dots(1)$$

We have to find 'a' such that

$$y''_p - 2y'_p + 5y_p = e^{2x} \quad \dots(2)$$

$$\begin{aligned} \text{From Eqn. (1)} \quad y'_p &= 2a e^{2x} \\ y''_p &= 4a e^{2x} \\ \text{Eqn. (2)} \Rightarrow 4a e^{2x} - 4a e^{2x} + 5a e^{2x} &= e^{2x} \\ 5a e^{2x} &= e^{2x} \end{aligned}$$

Equating the coefficients

$$5a = 1$$

$$a = \frac{1}{5}$$

$$\text{Eqn. (1),} \quad y_p = \frac{1}{5} e^{2x}$$

$$\therefore y = \text{C.F.} + \text{P.I.}$$

$$y = e^x (C_1 \cos 2x + C_2 \sin 2x) + \frac{1}{5} e^{2x}.$$

3. Solve using the method of undetermined coefficients

$$y'' - 5y' + 6y = \sin 2x.$$

**Solution.** We have

$$(D^2 - 5D + 6)y = \sin 2x$$

$$\text{A.E. is} \quad m^2 - 5m + 6 = 0$$

$$\text{i.e.,} \quad (m - 2)(m - 3) = 0$$

$$m = 2, 3$$

$$\therefore \text{C.F.} = C_1 e^{2x} + C_2 e^{3x}$$

$$\phi(x) = \sin 2x \text{ and } 0 \text{ is not a root of the A.E.}$$

We assume for P.I. in the form

$$y_p = a \cos 2x + b \sin 2x \quad \dots(1)$$

We have to find 'a' and 'b' such that

$$y''_p - 5y'_p + 6y_p = \sin 2x \quad \dots(2)$$

$$\text{From Eqn. (1),} \quad y'_p = -2a \sin 2x + 2b \cos 2x$$

$$y''_p = -4a \cos 2x - 4b \sin 2x$$

Eqn. (2) becomes

$$-4a \cos 2x - 4b \sin 2x - 5(-2a \sin 2x + 2b \cos 2x) + 6(a \cos 2x + b \sin 2x) = \sin 2x$$

$$(10a + 2b) \sin 2x + (2a - 10b) \cos 2x = \sin 2x$$

Comparing the coefficients, we get

$$10a + 2b = 1$$

$$\text{and} \quad 2a - 10b = 0$$

$$\text{Solving we get,} \quad a = \frac{5}{52}$$

$$b = \frac{1}{52}$$

Eqn. (1) becomes

$$\text{P.I.} = y_p = \frac{5}{52} \cos 2x + \frac{1}{52} \sin 2x$$

$$y = \text{C.F.} + \text{P.I.} = C_1 e^{2x} + C_2 e^{3x} + \frac{1}{52} (\cos 2x + \sin 2x).$$

4. Solve by the method of undetermined coefficients

$$y'' + y' - 2y = x + \sin x.$$

**Solution.** We have

$$(D^2 + D - 2) y = x + \sin x$$

A.E. is  $m^2 + m - 2 = 0$

i.e.,  $(m - 1)(m + 2) = 0, m = 1, -2$

$$\text{C.F.} = C_1 e^x + C_2 e^{-2x}$$

$$\phi(x) = x + \sin x \text{ and } 0 \text{ is not root of the A.E.}$$

We assume for P.I. in the form

$$y_p = a + bx + c \cos x + d \sin x. \quad \dots(1)$$

We have to find  $a, b, c,$  and  $d$  such that

$$y_p'' + y_p' - 2y_p = x + \sin x \quad \dots(2)$$

From (1),

$$\begin{aligned} y_p' &= b - c \sin x + d \cos x \\ y_p'' &= -c \cos x - d \sin x \end{aligned}$$

Eqn. (2), becomes

$$-c \cos x - d \sin x + b - c \sin x + d \cos x - 2(a + bx + c \cos x + d \sin x) = x + \sin x$$

$$(-2a + b) - 2bx + (-3c - d) \sin x + (c - 3d) \cos x = x + \sin x$$

Comparing the coefficients, we get

$$-2a + b = 0, -2b = 1, -3c - d = 1, c - 3d = 0$$

Solving, we get

$$a = \frac{-1}{4}, b = \frac{-1}{2}, c = \frac{-3}{10}, d = \frac{-1}{10}$$

Eqn. (1), becomes

$$\begin{aligned} y_p &= \frac{-1}{4} - \frac{1}{2}x - \frac{3}{10} \sin x - \frac{1}{10} \cos x \\ &= -\frac{1}{4}(2x + 1) - \frac{1}{10}(3 \sin x + \cos x) \end{aligned}$$

∴ The general solution is

$$\begin{aligned} y &= \text{C.F.} + \text{P.I.} \\ &= C_1 e^x + C_2 e^{-2x} - \frac{1}{4}(2x + 1) - \frac{1}{10}(3 \sin x + \cos x). \end{aligned}$$



5. Solve by the method of undetermined coefficients

$$y'' + 4y = x^2 + e^{-x}.$$

**Solution.** We have  $(D^2 + 4)y = x^2 + e^{-x}$

A.E. is  $m^2 + 4 = 0$

i.e.,  $m^2 = -4$

i.e.,  $m = \pm 2i$

$$\text{C.F.} = C_1 \cos 2x + C_2 \sin 2x$$

$$\phi(x) = x^2 + e^{-x}$$

where 0 and  $-1$  is not a root of the A.E.

We assume for P.I. in the form

$$y_p = a + bx + cx^2 + de^{-x} \quad \dots(1)$$

We have to find  $a$ ,  $b$ ,  $c$ , and  $d$  such that

$$y_p'' + 4y_p = x^2 + e^{-x} \quad \dots(2)$$

From (1),

$$y_p' = b + 2cx - de^{-x}$$

$$y_p'' = 2c + de^{-x}$$

Eqn. (2)  $\Rightarrow 2c + de^{-x} + 4(a + bx + cx^2 + de^{-x}) = x^2 + e^{-x}$

$$(2c + 4a) + 4bx + 4cx^2 + 5de^{-x} = x^2 + e^{-x}$$

Equating the coefficients

$$2c + 4a = 0, 4b = 0, 4c = 1, 5d = 1$$

Solving we get

$$a = -\frac{1}{8}, b = 0, c = \frac{1}{4}, d = \frac{1}{5}$$

Equation (1) becomes

$$\text{P.I.} = y_p = -\frac{1}{8} + \frac{1}{4}x^2 + \frac{1}{5}e^{-x} = \frac{1}{8}(2x^2 - 1) + \frac{1}{5}e^{-x}$$

$\therefore$  The general solution is

$$y = \text{C.F.} + \text{P.I.}$$

$$= c_1 \cos 2x + c_2 \sin 2x + \frac{1}{8}(2x^2 - 1) + \frac{1}{5}e^{-x}.$$

6. Solve by the method of undetermined coefficients

$$y'' + y' - 4y = x + \cos 2x.$$

**Solution.** We have

$$(D^2 + D - 4)y = x + \cos 2x$$

A.E. is  $m^2 - m - 4 = 0$

$$\therefore m = \frac{+1 \pm \sqrt{1+4}}{2} = \frac{1 \pm \sqrt{5}}{2}$$

$$\therefore \text{C.F.} = \frac{1 + \sqrt{5}}{2}, \frac{1 - \sqrt{5}}{2}$$

$$\text{C.F.} = C_1 e^{\left(\frac{1+\sqrt{5}}{2}\right)x} + C_2 e^{\left(\frac{1-\sqrt{5}}{2}\right)x}$$

We assume for P.I. in the form

$$y_p = a + bx + c \cos 2x + d \sin 2x \quad \dots(1)$$

Since  $0, \pm i$  are not roots of the A.E.

We have to find  $a, b, c$  and  $d$  such that

$$y''_p - y'_p - 4y_p = x + \cos 2x \quad \dots(2)$$

From Eqn. (1)

$$y'_p = b - 2c \sin 2x + 2d \cos 2x$$

$$y''_p = -4c \cos 2x - 4d \sin 2x$$

Now Eqn. (2) becomes,

$$\begin{aligned} -4c \cos 2x - 4d \sin 2x - (b - 2c \sin 2x + 2d \cos 2x) - [4(a + bx + c \cos 2x + d \sin 2x)] \\ = x + \cos 2x \end{aligned}$$

Comparing the coefficients, we have

$$-4a - b = 0, -4b = 1 \text{ and}$$

$$-8c - 2d = 1, 2c - 8d = 0$$

Solving these we get,

$$a = \frac{1}{16}, b = \frac{-1}{4}, c = \frac{-2}{17}, d = \frac{-1}{34}$$

Therefore

$$\begin{aligned} \text{P.I.} &= \frac{1}{16} - \frac{1}{4}x - \frac{2}{17} \cos 2x - \frac{1}{34} \sin 2x \\ &= \frac{1}{16} (1 - 4x) - \frac{1}{34} (4 \cos 2x + \sin 2x) \end{aligned}$$

Hence the complete solution is

$$\begin{aligned} y &= \text{C.F.} + \text{P.I.} \\ &= C_1 e^{\left(\frac{1+\sqrt{5}}{2}\right)x} + C_2 e^{\left(\frac{1-\sqrt{5}}{2}\right)x} + \frac{1}{16} (1 - 4x) - \frac{1}{34} (4 \cos x + \sin 2x). \end{aligned}$$

7. Solve by the method of undetermined coefficients

$$(D^2 + 1) y = \sin x.$$

**Solution.** Here A.E. is

$$m^2 + 1 = 0 \text{ and its roots are } m = \pm i$$

Hence  $\text{C.F.} = C_1 \cos x + C_2 \sin x$

Note that  $\sin x$  is common in the C.F. and the R.H.S. of the given equation.

( $\pm i$  is the root of the A.E.)

Therefore P.I. is  $y$  the form

$$y_p = x (a \cos x + b \sin x) \quad \dots(1)$$

Since  $\pm i$  is root of the A.E.

We have to find  $a$  and  $b$  such that

$$y''_p + y_p = \sin x \quad \dots(2)$$

From Eqn. (1)

$$y'_p = x(-a \sin x + b \cos x) + (a \cos x + b \sin x)$$

$$\begin{aligned} y''_p &= x(-a \cos x - b \sin x) + (-a \sin x + b \cos x) - a \sin x \\ &\quad + b \cos x \\ &= x(-a \cos x - b \sin x) - 2a \sin x + 2b \cos x \end{aligned}$$

Then the given equation reduces to using the Eqn. (1)

$$x(-a \cos x - b \sin x) - 2a \sin x + 2b \cos x + x(a \cos x + b \sin x) = \sin x$$

Equating the coefficients, we get

$$\text{i.e., } -2a \sin x + 2b \cos x = \sin x$$

$$-2a = 1, \quad 2b = 0$$

$$a = \frac{-1}{2}, \quad b = 0$$

Thus P.I. is

$$y_p = \frac{-1}{2} x \cos x$$

$\therefore$

$$y = \text{C.F.} + \text{P.I.}$$

$$= C_1 \cos x + C_2 \sin x - \frac{1}{2} x \sin x.$$

**8. Solve by the method of undetermined coefficients**

$$(D^2 + 1) y = 4x - 2 \sin x.$$

**Solution.** A.E. is

$$m^2 + 1 = 0 \Rightarrow m = \pm i$$

$\therefore$

$$\text{C.F.} = C_1 \cos x + C_2 \sin x$$

$\phi(x) = 4x - 2 \sin x$ . We assume for P.I. in the form

$$y_p = a + bx + x(c \cos x + d \sin x) \quad \dots(1)$$

Since 0 is not the root of the A.E. and  $\pm i$  is the root of A.E.

We have to find  $a$  and  $b$  such that

$$y''_p + y_p = 4x - 2 \sin x \quad \dots(2)$$

From Eqn. (1)

$$y'_p = b + x(-c \sin x + d \cos x) + (c \cos x + d \sin x)$$

$$\begin{aligned} y''_p &= x(-c \cos x - d \sin x) + (-c \sin x + d \cos x) \\ &\quad + (-c \sin x + d \cos x) \end{aligned}$$

Eqn. (2), becomes

$$\begin{aligned} x(-c \cos x - d \sin x) + (-c \sin x + d \cos x) + (-c \sin x + d \cos x) a + bx \\ + x(\cos x + d \sin x) = 4x - 2 \sin x \end{aligned}$$

$$\text{i.e., } a + bx + (-2c \sin x + 2d \cos x) = 4x - 2 \sin x$$

Comparing the coefficients, we get,

$$a = 0, \quad b = 4, \quad -2c = -2, \quad 2d = 0$$

$$\text{i.e., } a = 0, \quad b = 4, \quad c = 1, \quad d = 0$$

Therefore the required P.I. (using Eqn. (1))

From Eqn. (1)  $\Rightarrow$  P.I. =  $4x + x \cos x$

$$\begin{aligned} \therefore y &= \text{C.F.} + \text{P.I.} \\ &= C_1 \cos x + C_2 \sin x + 4x + x \cos x. \end{aligned}$$

**9. Solve by the method of undetermined coefficients**

$$y'' + 3y' + 2y = x^2 + e^x.$$

**Solution.** A.E. is

$$m^2 - 3m + 2 = 0$$

$$\text{i.e., } (m - 1)(m - 2) = 0 \Rightarrow m = 1, 2$$

$$\therefore \text{C.F.} = C_1 e^x + C_2 e^{2x}$$

$$\phi(x) = x^2 + e^x$$

with reference to the form  $x^2$  we assume the P.I. in the form  $a + bx + cx^2$ . Since 0 is not a root of the A.E. and with reference to  $e^x$ . We assume the P.I. to be  $dxe^x$ , since Eqn. (1) is a root of the A.E.

We assume for P.I. in the form

$$y_p = a + bx + cx^2 + dxe^x \quad \dots(1)$$

We have to find  $a, b, c$  and  $d$  such that

$$y_p'' - 3y_p' + 2y_p = x^2 + e^x \quad \dots(2)$$

$$\text{From Eqn. (1)} \quad y_p' = b + 2cx + d(xe^x + e^x)$$

$$y_p'' = 2c + d(xe^x + 2e^x)$$

Now Eqn. (2) becomes,

$$\begin{aligned} (2c + dxe^x + 2de^x) - 3(b + 2cx + dxe^x + de^x) + 2(a + bx + cx^2 + dxe^x) &= x^2 + e^x \\ \text{i.e., } (2a - 3b + 2c) + (2b - 6c)x + 2cx^2 - de^x &= x^2 + e^x \end{aligned}$$

Comparing the coefficients, we get,

$$2a - 3b + 2c = 0, \quad 2b - 6c = 0, \quad 2c = 1, \quad -d = 1$$

$$\therefore d = -1, \quad c = \frac{1}{2}, \quad b = \frac{3}{2}, \quad a = \frac{7}{4}$$

$$\text{Hence from Eqn. (1)} \quad y_p = \frac{7}{4} + \frac{3}{2}x + \frac{1}{2}x^2 - xe^x$$

$$\therefore \text{P.I.} = y_p = \frac{1}{4}(7 + 6x + 2x^2 - 4xe^x)$$

$$\therefore y = \text{C.F.} + \text{P.I.}$$

$$y = C_1 e^x + C_2 e^{2x} + \frac{1}{4}(7 + 6x + 2x^2 - 4xe^x).$$

**10. Solve by the method of undetermined coefficients**

$$(D^2 + 1)y = 4x \cos x - 2 \sin x.$$

**Solution.** A.E. is

$$m^2 + 1 = 0$$

$$m = \pm i$$

$$\text{C.F.} = C_1 \cos x + C_2 \sin x$$

Note that both  $\cos x$  and  $\sin x$  are common in the C.F. and the R.H.S. of the given equation. Now P.I. corresponding to  $4x \cos x$  is of the form

$$y_1 = x \{(a + bx) \cos x + (c + dx) \sin x\}$$

and P.I. corresponding to  $2 \sin x$  is

$$y_2 = x \{e \cos x + f \sin x\}$$

Hence, we take P.I. in the form

$$\begin{aligned} y_p &= y_1 + y_2 \\ &= (ax + xe + bx^2) \cos x + (cx + fx + dx^2) \sin x \\ &= \{(a + e)x + bx^2\} \cos x + \{(c + f)x + dx^2\} \sin x \end{aligned}$$

P.I. must be of the form  $a + e = c_1$ ,  $b = c_2$

$$c + f = c_3, \quad d = c_4$$

$$y_p = (c_1x + c_2x^2) \cos x + (c_3x + c_4x^2) \sin x \quad \dots(1)$$

Differentiating, we get

$$y'_p = (c_1x + c_2x^2)(-\sin x) + \cos x (c_1 + 2xc_2) + (c_3x + c_4x^2) \cos x + \sin x (c_3 + 2xc_4)$$

$$\begin{aligned} y''_p &= (c_1x + c_2x^2)(-\cos x) + (-\sin x)(c_1 + 2xc_2) + \cos x (2c_2) \\ &\quad + (c_1 + 2xc_2)(-\sin x) + (c_3x + c_4x^2)(-\sin x) \\ &\quad + (\cos x)(c_3 + 2xc_4) + \sin x (2c_4) + (c_3 + 2xc_4) \cos x \end{aligned}$$

$$y''_p = [(-2c_1 + 2c_4) + (-4c_2 - c_3)x - c_4x^2] \sin x + [(2c_2 + 2c_3) + (4c_4 - c_1)x - c_2x^2] \cos x$$

Substituting these values in the given equation and simplifying, we get

$$\begin{aligned} \{(2c_2 + 2c_3) + 4c_4x\} \cos x + \{(-2c_1 + 2c_4) - 4c_2x\} \sin x \\ = 4x \cos x - 2 \sin x \end{aligned}$$

Comparing the coefficients, we obtain,

$$2c_2 + 2c_3 = 0, \quad 4c_4 = 4, \quad 2c_1 + 2c_4 = -2, \quad 4c_2 = 0$$

Solving we get  $c_2 = 0$ ,  $c_4 = 1$  and hence

$$c_3 = 0, \quad c_1 = 2$$

From Eqn. (1), the required P.I. is

$$\begin{aligned} y_p &= (2x + 0) \cos x + (0x + x^2) \sin x = 2x \cos x + x^2 \sin x \\ &= 2x \cos x + x^2 \sin x \end{aligned}$$

$\therefore$  The general solution is

$$\begin{aligned} y &= \text{C.F.} + \text{P.I.} \\ &= C_1 \cos x + C_2 \sin x + 2x \cos x + x^2 \sin x. \end{aligned}$$

**11. Solve by the method of undetermined coefficients**

$$(D^3 + 3D^2 + 2D)y = x^2 + 4x + 8.$$

**Solution.** A.E. is

$$m^3 + 3m^2 + 2m = 0$$

$$\text{i.e., } m(m^2 + 3m + 2) = 0$$

$$m(m+1)(m+2) = 0$$

Hence the roots are  $m = 0, -1, -2$

$$\therefore \text{C.F.} = C_1 + C_2e^{-x} + C_3e^{-2x}$$

Since the constant term appears in both C.F. and the R.H.S. of the given equation we take P.I. in the form,

$$\begin{aligned} y_p &= x(a_0 + a_1x + a_2x^2) \\ &= a_0x + a_1x^2 + a_2x^3 \end{aligned} \quad \dots(1)$$

We have to find  $a_0, a_1,$  and  $a_2$  such that

$$y_p''' + 3y_p'' + 2y_p' = x^2 + 4x + 8 \quad \dots(2)$$

$$\text{From Eqn. (1)} \Rightarrow y_p' = a_0 + a_1(2x) + 3x^2a_2$$

$$y_p'' = 2a_1 + 6a_2x$$

$$y_p''' = 6a_2$$

Eqn. (2) becomes,

$$6a_2 + 3(2a_1 + 6a_2x) + 2(a_0 + 2a_1x + 3a_2x^2) = x^2 + 4x + 8$$

$$\text{i.e., } 6a_2x^2 + (4a_1 + 18a_2)x + 2a_0 + 6a_1 + 6a_2 = x^2 + 4x + 8$$

Comparing the coefficients, we get

$$6a_2 = 1, 4a_1 + 18a_2 = 4, 2a_0 + 6a_1 + 6a_2 = 8$$

Solving these equations, we get

$$a_0 = \frac{11}{4}, a_1 = \frac{1}{4}, a_2 = \frac{1}{6}$$

Eqn. (1) becomes

$$y_p = x \left( \frac{11}{4} + \frac{1}{4}x + \frac{1}{6}x^2 \right)$$

$\therefore$  The general solution is

$$\begin{aligned} y &= \text{C.F.} + \text{P.I.} \\ &= C_1 + C_2e^{-x} + C_3e^{-2x} + \frac{11}{4}x + \frac{x^2}{4} + \frac{x^3}{6}. \end{aligned}$$

**12.** Solve by the method of undetermined coefficients;

$$(D^3 + 2D^2 - D - 2)y = x^2 + e^x.$$

**Solution.** A.E. is

$$m^3 + 2m^2 - m - 2 = 0$$

$$\text{i.e., } (m+2)(m-1)(m+1) = 0$$

$$\text{So that } m = \pm 1, -2$$

Hence C.F. is

$$\text{C.F.} = C_1e^x + C_2e^{-x} + C_3e^{-2x}$$

Note that  $e^x$  is common in C.F. and the R.H.S. of the given equation.

Therefore P.I. is of the form

$$y_p = a + bx + cx^2 + dx e^x \quad \dots(1)$$

We have to find  $a, b, c$  and  $d$  such that

$$y_p''' + 2y_p'' - y_p' - 2y_p = x^2 + e^x \quad \dots(2)$$

Eqn. (1), we get

$$\begin{aligned}y'_p &= b + 2cx + dx e^x + de^x \\y''_p &= 2c + dx e^x + de^x + de^x \\&= 2c + dx e^x + 2de^x \\y'''_p &= dx e^x + de^x + 2de^x \\&= dx e^x + 3de^x\end{aligned}$$

Substituting these values in the eqn. (2) we get

$$(-2a - b + 4c) - 2(b + c)x - 2cx^2 + 6de^x = x^2 + e^x$$

Comparing the coefficients, we get

$$\begin{aligned}-2a - b + 4c &= 0, \quad -2(b + c) = 0, \\-2c &= 1, \quad 6d = 1\end{aligned}$$

Solving these equations, we get,

$$a = \frac{-5}{4}, \quad b = \frac{1}{2}, \quad c = \frac{-1}{2}, \quad d = \frac{1}{6}$$

Using these values in Eqn. (1), we get required P.I. is

$$y_p = -\frac{5}{4} + \frac{1}{2}x - \frac{1}{2}x^2 + \frac{1}{6}x e^x$$

Therefore,

$$\begin{aligned}y &= \text{C.F.} + \text{P.I.} \\&= C_1 x + C_2 e^{-x} + C_3 e^{-2x} - \frac{1}{4}(2x^2 - 2x + 5) + \frac{1}{6}x e^x.\end{aligned}$$

## EXERCISE 5.5

Solve the following equations by the method of undetermined coefficients:

1.  $y'' + 9y = x^2.$  [Ans.  $y = C_1 \cos 3x + C_2 \sin 3x + \frac{1}{81}(9x^2 - 2)$ ]

2.  $y'' + 4y' = x^2 + x.$  [Ans.  $y = C_1 e^{2x} + C_2 e^{-2x} - \frac{1}{8}(2x^2 + 2x + 1)$ ]

3.  $y'' - 6y' + 10y = x^2.$  [Ans.  $y = e^{3x}(C_1 \cos x + C_2 \sin x) + \frac{1}{50}(5x^2 + 6x + 35)$ ]

4.  $y'' - 2y' + y = x^2 - 1.$  [Ans.  $y = (C_1 + C_2 x)e^x + x^2 + 4x + 5$ ]

5.  $y'' + 4y = e^{-2x}.$  [Ans.  $y = C_1 \cos 2x + C_2 \sin 2x + \frac{1}{8}e^{-2x}$ ]

6.  $y'' + y' - 12y = e^{2x}.$  [Ans.  $y = C_1 e^{3x} + C_2 e^{-4x} - \frac{1}{6}e^{2x}$ ]

$$7. y'' + y' - 6y = e^{-3x}. \quad \left[ \text{Ans. } y = C_1 e^{-3x} + C_2 e^{-2x} - \frac{1}{5} x e^{-3x} \right]$$

$$8. y'' + 3y' + 2y = e^{-2x}. \quad \left[ \text{Ans. } y = C_1 e^{-x} + C_2 e^{-2x} - x e^{-2x} \right]$$

$$9. y'' + 4y' + 4y = x^2 + e^x. \quad \left[ \text{Ans. } y = (C_1 + C_2 x) e^{-2x} + \frac{1}{8} (2x^2 - 4x + 3) + \frac{1}{9} e^x \right]$$

$$10. y'' - 5y' + 6y = x + e^{2x}. \quad \left[ \text{Ans. } y = C_1 e^{2x} + C_2 e^{3x} + \frac{1}{36} (6x + 5) - x e^{2x} \right]$$

$$11. y'' + y = x^2 + e^{2x}. \quad \left[ \text{Ans. } y = C_1 \cos x + C_2 \sin x + (x^2 - 2x) + \frac{1}{5} e^{2x} \right]$$

$$12. y'' + 25y = \cos 2x. \quad \left[ \text{Ans. } y = C_1 \cos 5x + C_2 \sin 5x + \frac{1}{21} \cos 2x \right]$$

$$13. y'' + 4y' + 4y = \sin x. \quad \left[ \text{Ans. } y = (C_1 + C_2 x) e^{-2x} - \frac{1}{25} (4 \cos x - 3 \sin x) \right]$$

$$14. y'' + 4y' - 3y = \sin 3x. \quad \left[ \text{Ans. } y = C_1 e^x + C_2 e^{-3x} - \frac{1}{30} (\cos 3x + 2 \sin 3x) \right]$$

$$15. y'' + 9y = \sin 3x. \quad \left[ \text{Ans. } y = C_1 \cos 3x + C_2 \sin 3x - \frac{1}{6} x \cos 3x \right]$$

$$16. y'' - y = 10 \sin^2 x. \quad \left[ \text{Ans. } y = C_1 e^x + C_2 e^{-x} - 5 + \cos 2x \right]$$

$$17. y'' + y' - 2y = x + \cos x. \quad \left[ \text{Ans. } y = C_1 e^x + C_2 e^{-2x} - \frac{1}{4} (2x + 1) - \frac{1}{10} (\sin x - 3 \cos x) \right]$$

$$18. y'' - 2y' - 3y = e^{-x} + 5 \cos 2x. \quad \left[ \text{Ans. } y = C_1 e^{-x} + C_2 e^{3x} - \frac{1}{4} x e^{-x} - \frac{1}{5} (4 \sin 2x + 7 \cos 2x) \right]$$

$$19. y'' + 4y = x^2 + \sin 2x. \quad \left[ \text{Ans. } y = C_1 \cos 2x + C_2 \sin 2x + \frac{1}{8} (2x^2 - 1) - \frac{1}{4} x \cos 2x \right]$$

$$20. y'' + 3y' + 2y = x^2 + \cos x. \quad \left[ \text{Ans. } y = C_1 e^{-x} + C_2 e^{-2x} + \frac{1}{4} (2x^2 - 6x + 7) + \frac{1}{10} (3 \sin x + \cos x) \right]$$

$$21. y'' + y' - 6y = \cos 2x + e^{2x}. \quad \left[ \text{Ans. } y = C_1 e^{2x} + C_2 e^{-3x} + \frac{1}{52} (\sin 2x - 5 \cos 2x) + \frac{1}{5} x e^{2x} \right]$$



$$22. \quad y'' + 2y' + y = e^x \cos 2x. \quad \left[ \text{Ans. } y = (C_1 + C_2 x)e^{-x} - \frac{1}{8} e^x \cos 2x \right]$$

$$23. \quad y'' + y = xe^{2x}. \quad \left[ \text{Ans. } y = C_1 \cos x + C_2 \sin x + \frac{1}{2} (x-1) e^{2x} \right]$$

$$24. \quad y'' - 2y' = e^x \sin x. \quad \left[ \text{Ans. } y = C_1 + C_2 e^{2x} - \frac{1}{2} e^x \sin x \right]$$

$$25. \quad y'' - 2y' + 3y = x^3 + \sin x.$$

$$\left[ \text{Ans. } y = e^x (C_1 \cos \sqrt{3}x + C_2 \sin \sqrt{3}x) + \frac{1}{27} (9x^3 + 18x^2 + 6x - 8) + \frac{1}{4} (\sin x + \cos x) \right]$$

$$26. \quad (D^3 - 3D + 2) y = x^2 + e^{-2x}. \quad \left[ \text{Ans. } y = C_1 e^{-2x} + (C_2 + C_3 x)e^x - \frac{1}{2} e^{-x} + \frac{1}{4} (2x^2 + 6x + 9) \right]$$

$$27. \quad (D^3 + 2D^2 - D - 2) y = e^x + x^2.$$

$$\left[ \text{Ans. } y = C_1 e^x + C_2 e^{-x} + C_3 e^{-2x} + \frac{1}{6} e^{-x} - \frac{1}{4} (2x^2 - 2x + 9) \right]$$

$$28. \quad (D^3 + 2D^2 + 1) y = e^{2x} + \sin 2x.$$

$$\left[ \text{Ans. } y = C_1 + (C_2 + C_3 x)e^{-x} + \frac{e^{x2x}}{18} + \frac{1}{50} (3\cos 2x - 4\sin 2x) \right]$$

$$29. \quad (D^3 - D^2 - D + 1) y = x^2 + 1. \quad \left[ \text{Ans. } y = (C_1 + C_2 x)e^x + C_3 e^{-x} + (x^2 + 2x + 5) \right]$$

$$30. \quad (D^3 - D^2 + 3D + 5) y = e^x \cos 2x.$$

$$\left[ \text{Ans. } y = C_1 e^{-x} + e^x (C_2 \cos 2x + C_3 \sin 2x) + \frac{1}{16} x e^x (\sin 2x - \cos 2x) \right]$$

$$31. \quad (D^3 - 6D^2 + 11D - 6) y = 2xe^{-x}. \quad \left[ \text{Ans. } y = C_1 e^x + C_2 e^{2x} + C_3 e^{3x} - \frac{1}{144} (12x + 13)e^{-x} \right]$$

$$32. \quad (D^3 - D^2 - 2D) y = x^2 + x + 1. \quad \left[ \text{Ans. } y = C_1 + C_2 e^{-x} + C_3 e^{2x} - \frac{1}{6} x (x^2 + 6) \right]$$

## 5.7 SOLUTION OF SIMULTANEOUS DIFFERENTIAL EQUATIONS

Let us suppose that  $x$  and  $y$  are functions of an independent variable ' $t$ ' connected by a system of first order equation with  $D = \frac{d}{dt}$

$$f_1(D) x + f_2(D) y = \phi_1(t) \quad \dots(1)$$

$$g_1(D) x + g_2(D) y = \phi_2(t) \quad \dots(2)$$

By solving a system of linear algebraic equations in cancelling either of the dependent variables ( $x$  or  $y$ ) operating (1) with  $g_1(D)$  and (2) with  $f_1(D)$ ,  $x$  cancels out by subtraction. We obtain a second order differential equation in  $y$ . Which can be solved  $x$  can be obtained independently by cancelling  $y$  or by substituting the obtained  $y(t)$  in a suitable equation.

### WORKED OUT EXAMPLES

1. Solve  $\frac{dx}{dt} - 7x + y = 0$ ,  $\frac{dx}{dt} - 2x - 5y = 0$ .

**Solution.** Taking  $D = \frac{d}{dt}$ , we have the system of equations

$$(D - 7) x + y = 0 \quad \dots(1)$$

$$- 2x + (D - 5) y = 0 \quad \dots(2)$$

Multiply (1) by 2 and operate (2) by  $(D - 7)$

i.e.,  $2(D - 7) x + 2y = 0$

$$- 2(D - 7) x + (D - 5)(D - 7) y = 0$$

---

Adding  $[(D - 5)(D - 7) + 2] y = 0$  or

$$(D^2 - 12D + 37) y = 0$$

A.E. is  $m^2 - 12m + 37 = 0$

or  $(m - 6)^2 + 1 = 0$

$$\Rightarrow m - 6 = \pm i$$

$$m = 6 \pm i$$

Thus  $y = e^{6t} (C_1 \cos t + C_2 \sin t) \quad \dots(3)$

By considering  $\frac{dy}{dt} - 2x - 5y = 0$ , we get

$$x = \frac{1}{2} \left( \frac{dy}{dt} - 5y \right)$$

$$\begin{aligned} \therefore x &= \frac{1}{2} \left\{ \frac{d}{dt} [e^{6t} (C_1 \cos t + C_2 \sin t)] - 5e^{6t} (C_1 \cos t + C_2 \sin t) \right\} \\ &= \frac{1}{2} \left\{ e^{6t} (-C_1 \sin t + C_2 \cos t) + 6e^{6t} (C_1 \cos t + C_2 \sin t) \right. \\ &\quad \left. - 5e^{6t} (C_1 \cos t + C_2 \sin t) \right\} \end{aligned}$$

$$x = \frac{1}{2} \left\{ e^{6t} (-C_1 \sin t + C_2 \cos t) + e^{6t} (C_1 \cos t + C_2 \sin t) \right\}$$

Thus  $x = \frac{1}{2} \left\{ (C_1 + C_2) e^{6t} \cos t + (C_2 - C_1) e^{6t} \sin t \right\} \quad \dots(4)$

(3) and (4) represents the complete solution of the given system of equations.

2. Solve:  $\frac{dx}{dt} = 2x - 3y$ ,  $\frac{dy}{dt} = y - 2x$  given  $x(0) = 8$  and  $y(0) = 3$ .

**Solution.** Taking  $D = \frac{d}{dt}$  we have the system of equations.

$$Dx = 2x - 3y; \quad Dy = y - 2x$$

$$\text{i.e.,} \quad (D - 2)x + 3y = 0 \quad \dots(1)$$

$$2x + (D - 1)y = 0 \quad \dots(2)$$

Multiplying (1) by 2 and (2) by  $(D - 2)$ , we get

$$2(D - 2)x + 6y = 0$$

$$2(D - 2)x + (D - 1)(D - 2)y = 0$$

Subtracting, we get  $(D^2 - 3D - 4)y = 0$

$$\text{A.E. is} \quad m^2 - 3m - 4 = 0$$

$$\text{or} \quad (m - 4)(m + 1) = 0 \quad \Rightarrow \quad m = 4, -1$$

$$\therefore \quad y = C_1 e^{4t} + C_2 e^{-t} \quad \dots(3)$$

By considering  $\frac{dy}{dt} = y - 2x$ , we get

$$x = \frac{1}{2} \left\{ y - \frac{dy}{dt} \right\}$$

$$\begin{aligned} \text{i.e.,} \quad x &= \frac{1}{2} \left\{ C_1 e^{4t} + C_2 e^{-t} - (4C_1 e^{4t} - C_2 e^{-t}) \right\} \\ &= \frac{1}{2} (-3C_1 e^{4t} + 2C_2 e^{-t}) \end{aligned} \quad \dots(4)$$

We have conditions  $x = 8$ ,  $y = 3$  at  $t = 0$

Hence (3) and (4) become  $C_1 + C_2 = 3$  and  $-\frac{3C_1}{2} + C_2 = 8$ .

Solving these equations, we get  $C_2 = 5$ ,  $C_1 = -2$

Thus

$$x = 3e^{4t} + 5e^{-t}$$

$$y = -2e^{4t} + 5e^{-t} \text{ is the required solution.}$$

3. Solve:  $\frac{dx}{dt} - 2y = \cos 2t$ ,  $\frac{dy}{dt} + 2x = \sin 2t$  given that  $x = 1$ ,  $y = 0$  at  $t = 0$ .

**Solution.** Taking  $D = \frac{d}{dt}$  we have the system of equations

$$Dx - 2y = \cos 2t \quad \dots(1)$$

$$2x + Dy = \sin 2t \quad \dots(2)$$

Multiplying (1) by  $D$  and (2) by 2, we have

$$\begin{aligned} D^2x - 2Dy &= D(\cos 2t) = -2 \sin 2t \\ 4x + 2Dy &= 2 \sin 2t \end{aligned}$$

Adding, we get  $(D^2 + 4)x = 0$

A.E. is  $m^2 + 4 = 0 \Rightarrow m = \pm 2i$

$\therefore x = C_1 \cos 2t + C_2 \sin 2t$  ... (3)

By considering  $\frac{dx}{dt} - 2y = \cos 2t$ , we get

$$y = \frac{1}{2} \left[ \frac{dx}{dt} - \cos 2t \right]$$

i.e.,  $y = \frac{1}{2} \left[ \frac{d}{dt} (C_1 \cos 2t + C_2 \sin 2t) - \cos 2t \right]$

$$= \frac{1}{2} [-2C_1 \sin 2t + 2C_2 \cos 2t - \cos 2t]$$

$$y = -C_1 \sin 2t + \left( C_2 - \frac{1}{2} \right) \cos 2t$$
 ... (4)

Equation (3) and (4) represents the general solution

Applying the given conditions  $x = 1$  at  $t = 0$

Hence (3) becomes,  $1 = C_1 + 0 \Rightarrow C_1 = 1$   
 $y = 0$  at  $t = 0$

Hence (4) becomes,  $0 = 0 + \left( C_2 - \frac{1}{2} \right) \Rightarrow C_2 = \frac{1}{2}$

Substituting these values in (3) and (4), we get

$$x = \cos 2t + \frac{1}{2} \sin 2t$$

$$y = -\sin 2t$$

Which is the required solution.

### EXERCISE 5.6

1. Solve  $\frac{dx}{dt} + 2y = -\sin t$ ,  $\frac{dy}{dt} - 2x = \cos t$ .

$$\left[ \begin{aligned} \text{Ans. } x &= -C_1 \sin 2t + C_2 \cos 2t - \cos t \\ y &= C_1 \cos 2t + C_2 \sin 2t - \sin t \end{aligned} \right]$$

2. Solve  $\frac{dx}{dt} + y = e^t$ ,  $\frac{dy}{dt} - x = e^{-t}$ .

$$\left[ \begin{aligned} \text{Ans. } x &= -C_1 \sin t + C_2 \cos t + \sin h t \\ y &= C_1 \cos t + C_2 \sin t + \sin h t \end{aligned} \right]$$

3. Solve  $\frac{dx}{dt} + x - y = e^t$ ,  $\frac{dy}{dt} + y - x = 0$ .

$$\left[ \begin{aligned} \text{Ans. } x &= C_1 + C_2 e^{-2t} + 2e^{t/3} \\ y &= C_1 - C_2 e^{-2t} + e^{t/3} \end{aligned} \right]$$

### ADDITIONAL PROBLEMS (From Previous Years VTU Exams.)

1. Solve  $(D^3 - 1)y = (e^x + 1)^2$ .

**Solution.** Refer page no. 226. Example 5.

2.  $\frac{d^2y}{dx^2} + 4\frac{dy}{dx} - 12y = e^{2x} - 3 \sin 2x$ .

**Solution.** We have

$$(D^2 + 4D - 12)y = e^{2x} - 3 \sin 2x$$

A.E. is  $m^2 + 4m - 12 = 0$

$$(m + 6)(m - 2) = 0 \Rightarrow m = -6 \text{ and } 2$$

$\therefore$  C.F. =  $C_1 e^{-6x} + C_2 e^{2x}$

$$\begin{aligned} \text{P.I.} &= \frac{e^{2x}}{D^2 + 4D - 12} - \frac{3 \sin 2x}{D^2 + 4D - 12} \\ &= \text{P.I.}_1 - \text{P.I.}_2 \end{aligned}$$

Now,  $\text{P.I.}_1 = \frac{e^{2x}}{D^2 + 4D - 12} = \frac{e^{2x}}{2^2 + 4 \cdot 2 - 12} \quad (D \rightarrow 2) \quad Dr = 0$

Differential denominator and multiply 'x'

$$= \frac{x e^{2x}}{2D + 4} = \frac{x e^{2x}}{2 \cdot 2 + 4} = \frac{x e^{2x}}{8} \quad (D \rightarrow 2)$$

$$\text{P.I.}_2 = \frac{3 \sin 2x}{D^2 + 4D - 12} \quad (D^2 \rightarrow -2^2 = -4)$$

$$\begin{aligned} \text{P.I.}_2 &= \frac{3 \sin 2x}{-4 + 4D - 12} = \frac{3 \sin 2x}{4(D - 4)} \times \frac{D + 4}{D + 4} \\ &= \frac{3(D + 4) \sin 2x}{4(D^2 - 16)} \end{aligned}$$

$$= \frac{3(2 \cos 2x + 4 \sin 2x)}{4(-20)} \quad (D^2 \rightarrow -4)$$

$\therefore$   $\text{P.I.}_2 = \frac{3(\cos 2x + 2 \sin 2x)}{-40}$

$\therefore$  The general solution:  $y = \text{C.F.} + \text{P.I.}$

$$y = C_1 e^{-6x} + C_2 e^{2x} + \frac{x e^{2x}}{8} + \frac{3(\cos 2x + 2 \sin 2x)}{40}$$

3. Solve  $(D^2 + 5D + 6)y = \cos x + e^{-2x}$ .

**Solution.** Refer page no. 229. Example 3.

4. Solve  $\frac{d^3 y}{dx^3} - 7 \frac{dy}{dx} + 6y = 1 - x + x^2$ .

**Solution.** We have

$$(D^3 - 7D + 6)y = 1 - x + x^2$$

A.E. is  $m^3 - 7m + 6 = 0$

$m = 1$  is a root by inspection.

We now apply the method of synthetic division.

$$\begin{array}{r|rrrr} 1 & 1 & 0 & -7 & 6 \\ & & 0 & 1 & -6 \\ \hline & 1 & 1 & -6 & 0 \end{array}$$

$$m^2 + m - 6 = 0 \quad \text{or} \quad (m + 3)(m - 2) = 0$$

$$\Rightarrow m = -3, 2$$

$m = 1, 2, -3$  are the roots of A.E.

$\therefore$

$$\text{C.F.} = C_1 e^x + C_2 e^{2x} + C_3 e^{-3x}$$

$$\text{P.I.} = \frac{1 - x + x^2}{D^3 - 7D + 6} = \frac{x^2 - x + 1}{6 - 7D + D^3}$$

P.I. is found by division

$$\begin{array}{r} \frac{x^2}{6} + \frac{2x}{9} + \frac{23}{54} \\ \hline 6 - 7D + D^3 \left| \begin{array}{l} x^2 - x + 1 \\ x^2 - \frac{7x}{3} + 0 \\ \hline \frac{4x}{3} + 1 \\ \frac{4x}{3} - \frac{14}{9} \\ \hline \frac{23}{9} \\ \frac{23}{9} \\ \hline 0 \end{array} \right. \end{array}$$

$\therefore$

$$\text{P.I.} = \frac{x^2}{6} + \frac{2x}{9} + \frac{23}{54} = \frac{1}{54} (9x^2 + 12x + 23)$$

$\therefore$  The general solution is  $y = \text{C.F.} + \text{P.I.}$

$$y = C_1 e^x + C_2 e^{2x} + C_3 e^{-3x} + \frac{1}{54} (9x^2 + 12x + 23)$$

5. Solve  $\frac{d^2 y}{dx^2} + 4y = x^2 + \cos 2x + 2^{-x}$ .

**Solution.** We have

$$(D^2 + 4)y = x^2 + \cos 2x + 2^{-x}$$

A.E. is  $m^2 + 4 = 0 \Rightarrow m = \pm 2i$

$\therefore$  C.F. =  $C_1 \cos 2x + C_2 \sin 2x$

$$\text{P.I.} = \frac{x^2}{D^2 + 4} + \frac{\cos 2x}{D^2 + 4} + \frac{2^{-x}}{D^2 + 4}$$

$$\text{P.I.} = \text{P.I.}_1 + \text{P.I.}_2 + \text{P.I.}_3$$

$\therefore$   $\text{P.I.}_1 = \frac{x^2}{D^2 + 4}$

P.I.<sub>1</sub> is found by division

$$\begin{array}{r}
 \frac{x^2}{4} - \frac{1}{8} \\
 \hline
 4 + D^2 \overline{) \begin{array}{l} x^2 \\ x^2 + \frac{1}{2} \\ \hline -\frac{1}{2} \\ -\frac{1}{2} \\ \hline 0 \end{array}}
 \end{array}
 \qquad
 \begin{aligned}
 \text{P.I.}_1 &= \frac{x^2}{4} - \frac{1}{8} \\
 &= \frac{1}{8}(2x^2 - 1)
 \end{aligned}$$

$\therefore$   $\text{P.I.}_1 = \frac{1}{8}(2x^2 - 1)$

$$\text{P.I.}_2 = \frac{\cos 2x}{D^2 + 4} \qquad (D^2 \rightarrow -2^2 = -4) \quad (Dr = 0)$$

Differentiate the denominator and multiply 'x'

$$\begin{aligned}
 &= x \frac{\cos 2x}{2D} \times \frac{D}{D} \\
 &= \frac{x(-\sin 2x) \cdot 2}{2D^2} \qquad (D^2 \rightarrow -4)
 \end{aligned}$$

$$\text{P.I.}_2 = \frac{x \sin 2x}{4}$$

$$\text{P.I.}_3 = \frac{2^{-x}}{D^2 + 4} = \frac{(e^{\log 2})^{-x}}{(D^2 + 4)} = \frac{e^{-\log 2 \cdot x}}{D^2 + 4} = \frac{e^{-\log 2 \cdot x}}{(-\log 2)^2 + 4}$$

$$\text{P.I.}_3 = \frac{2^{-x}}{(-\log 2)^2 + 4}$$

∴ The general solution is  $y = \text{C.F.} + \text{P.I.}$

$$y = C_1 \cos 2x + C_2 \sin 2x + \frac{1}{8}(2x^2 - 1) + \frac{x \sin x}{4} + \frac{2^{-x}}{(\log 2)^3 - 4}$$

6. Solve  $\frac{d^2 y}{dx^2} - 4 \frac{dy}{dx} + 4y = e^{2x} + \cos 2x + 4$ .

**Solution.** We have

$$(D^2 + 4D + 4)y = e^{2x} + \cos 2x + 4$$

A.E. is  $m^2 - 4m + 4 = 0$

i.e.,  $(m - 2)^2 = 0 \Rightarrow m = 2, 2$

∴ C.F. =  $(C_1 + C_2 x) e^{2x}$

$$\text{P.I.} = \frac{e^{2x}}{D^2 - 4D + 4} + \frac{\cos 2x}{D^2 - 4D + 4} + \frac{4}{D^2 - 4D + 4}$$

∴  $\text{P.I.} = \text{P.I.}_1 + \text{P.I.}_2 + \text{P.I.}_3$

Now,  $\text{P.I.}_1 = \frac{e^{2x}}{D^2 - 4D + 4} \quad (D \rightarrow 2)$

$$= \frac{e^{2x}}{4 - 8 + 4} \quad (Dr = 0)$$

$$= \frac{x e^{2x}}{2D - 4} \quad (Dr = 0 \text{ as } D \rightarrow 0)$$

$$\text{P.I.}_1 = \frac{x^2 e^{2x}}{2}$$

$$\text{P.I.}_2 = \frac{\cos 2x}{D^2 - 4D + 4} \quad (D^2 \rightarrow -2^2 = -4)$$

$$= \frac{\cos 2x}{-4D} \times \frac{D}{D}$$

$$= \frac{-\sin 2x \cdot 2}{4D^2} \quad (D^2 \rightarrow -4)$$

∴  $\text{P.I.}_2 = \frac{-\sin 2x}{8}$

$$\text{P.I.}_3 = \frac{4 \cdot e^{0x}}{D^2 - 4D + 4} \quad (D \rightarrow 0)$$



$$= \frac{4e^{0x}}{0-0+4} = \frac{4}{4} = 1$$

∴ The general solution is  $y = \text{C.F.} + \text{P.I.}$

$$\therefore y = (C_1 + C_2x)e^{2x} + \frac{x^2e^{2x}}{2} - \frac{\sin 2x}{8} + 1.$$

7. Solve  $\frac{d^3y}{dx^3} + \frac{d^2y}{dx^2} + 4\frac{dy}{dx} + 4y = x^2 - 4x - 6.$

**Solution.** We have

$$(D^3 + D^2 + 4D + 4)y = x^2 - 4x - 6$$

A.E. is  $m^3 + m^2 + 4m + 4 = 0$

$$m^2(m+1) + 4(m+1) = 0$$

$$(m+1)(m^2+4) = 0$$

$$m = -1, m = \pm 2i$$

∴ C.F. =  $C_1 e^{-x} + C_2 \cos 2x + C_3 \sin 2x$

$$\text{P.I.} = \frac{x^2 - 4x - 6}{D^3 + D^2 + 4D + 4}$$

P.I. is found by division

$$\begin{array}{r}
 \frac{x^2}{4} - \frac{3x}{2} - \frac{1}{8} \\
 \hline
 4 + 4D + D^2 + D^3 \quad \left| \begin{array}{l} x^2 - 4x - 6 \\ x^2 + 2x + \frac{1}{2} \\ \hline -6x - \frac{13}{2} \\ -6x - 6 \\ \hline -\frac{1}{2} \\ -\frac{1}{2} \\ \hline 0 \end{array} \right.
 \end{array}$$

Hence,  $\text{P.I.} = \frac{x^2}{4} - \frac{3x}{2} - \frac{1}{8}$

$$= \frac{1}{8}(2x^2 - 12x - 1)$$

∴ The general solution is  $y = \text{C.F.} + \text{P.I.}$

$$y = C_1 e^{-x} + C_2 \cos 2x + C_3 \sin 2x + \frac{1}{8}(2x^2 - 12x - 1).$$

8. Solve  $\frac{d^2 y}{dx^2} - 6 \frac{dy}{dx} + 25y = e^{2x} + \sin x + x$ .

**Solution.** We have

$$(D^2 - 6D + 25)y = e^{2x} + \sin x + x$$

A.E. is  $m^2 - 6m + 25 = 0$

$$m = \frac{6 \pm \sqrt{36 - 100}}{2} = \frac{6 \pm 8i}{2} = 3 \pm 4i$$

C.F. =  $e^{3x} (C_1 \cos 4x + C_2 \sin 4x)$

$$\text{P.I.} = \frac{e^{2x}}{D^2 - 6D + 25} + \frac{\sin x}{D^2 - 6D + 25} + \frac{x}{D^2 - 6D + 25}$$

P.I. = P.I.<sub>1</sub> + P.I.<sub>2</sub> + P.I.<sub>3</sub>

$$\begin{aligned} \text{P.I.}_1 &= \frac{e^{2x}}{D^2 - 6D + 25} && (D \rightarrow 2) \\ &= \frac{e^{2x}}{2^2 - 6(2) + 25} = \frac{e^{2x}}{17} \end{aligned}$$

$$\begin{aligned} \text{P.I.}_2 &= \frac{\sin x}{D^2 - 6D + 25} && (D \rightarrow -1^2 = -1) \\ &= \frac{\sin x}{-1 - 6D + 25} = \frac{\sin x}{24 - 6D} = \frac{\sin x}{6(4 - D)} \times \frac{4 + D}{4 + D} \\ &= \frac{(4 + D) \sin x}{6(4^2 - D^2)} && (D^2 = -1) \\ &= \frac{4 \sin x + \cos x}{6(17)} \end{aligned}$$

$\therefore$  P.I.<sub>2</sub> =  $\frac{4 \sin x + \cos x}{102}$

$\therefore$  P.I.<sub>3</sub> =  $\frac{x}{25 - 6D + D^2}$

P.I.<sub>3</sub> is found by division.

$$\begin{array}{r|l} & \frac{x}{25} + \frac{6}{625} \\ 25 - 6D + D^2 & \begin{array}{l} x \\ x - \frac{6}{25} \\ \hline \frac{6}{25} \\ \frac{6}{25} \\ \hline 0 \end{array} \end{array}$$

$$\begin{aligned} \text{P.I.}_3 &= \frac{x}{25} + \frac{6}{625} \\ &= 625(25x + 6) \end{aligned}$$

∴ The general solution is  $y = \text{C.F.} + \text{P.I.}$

$$y = e^{3x}(C_1 \cos 4x + C_2 \sin 4x) + \frac{e^{2x}}{17} + \frac{4 \sin x + \cos x}{102} + \frac{1}{625}(25x + 6).$$

9. Solve  $\frac{d^4 x}{dt^4} + 4x = \cos ht$ .

**Solution.** Refer page no. 225. Example 4.

10. Solve the differential equation  $\frac{d^2 y}{dx^2} - 5 \frac{dy}{dx} + 6y = e^{2x} + \sin x$  by the method of undetermined coefficients.

**Solution.** We have

$$(D^2 - 5D + 6)y = e^{2x} + \sin x$$

A.E. is  $m^2 - 5m + 6 = 0$

$$(m - 2)(m - 3) = 0$$

$$\Rightarrow m = 2 \text{ and } 3$$

$$\therefore \text{C.F.} = C_1 e^{2x} + C_2 e^{3x}$$

Let  $\phi(x) = e^{2x} + \sin x$  and we assume the P.I. in the form

$$y_p = ax e^{2x} + b \cos x + c \sin x \quad \dots(1)$$

Since 2 is root of the A.E.

We have to find  $a, b, c$  such that

$$y_p''' - 5y_p'' + 6y_p' = e^{2x} + \sin x \quad \dots(2)$$

From (1), we obtain

$$y_p' = a(2xe^{2x} + e^{2x}) - b \sin x + c \cos x$$

$$y_p'' = a(4xe^{2x} + 4e^{2x}) - b \cos x - c \sin x$$

Now (2) becomes

$$\begin{aligned} (4ax e^{2x} + 4ae^{2x} - b \cos x - c \sin x) - (10ax e^{2x} + 5a e^{2x} - 5b \sin x + 5c \cos x) \\ + (6axe^{2x} + 6b \cos x + 6c \sin x) = e^{2x} + \sin x \end{aligned}$$

$$\text{i.e., } -ae^{2x} + (5b - 5c) \cos x + (5c + 5b) \sin x = e^{2x} + \sin x$$

$$\Rightarrow -a = 1, 5b - 5c = 0, 5c + 5b = 1$$

$$\therefore a = -1, b = c, 5c + 5b = 1$$

$$\therefore a = -1, b = \frac{1}{10}, c = \frac{1}{10} \text{ by solving using these values in (1)}$$

we have 
$$y_p = -xe^{2x} + \frac{1}{10}(\cos x + \sin x)$$

Complete solution is  $y = \text{C.F.} + y_p$

$$y = C_1 e^{2x} + C_2 e^{3x} - xe^{2x} + \frac{1}{10}(\cos x + \sin x).$$

11. Using the method of undetermined coefficients solve  $\frac{d^2 y}{dx^2} + 2\frac{dy}{dx} + 4y = 2x^2 + 3e^{-x}$ .

**Solution.** We have  $(D^2 + 2D + 4)y = 2x^2 + 3e^{-x}$

A.E. is  $m^2 + 2m + 4 = 0$

$$\therefore m = \frac{-2 \pm \sqrt{4-16}}{2} = \frac{-2 \pm \sqrt{-12}}{2} = \frac{-2 \pm 2i\sqrt{3}}{2}$$

$$\therefore m = -1 \pm i\sqrt{3}$$

$$\therefore \text{C.F.} = e^{-x} \left\{ C_1 \cos(\sqrt{3}x) + \sin(\sqrt{3}x) \right\}$$

Let  $\phi(x) = 2x^2 + 3e^{-x}$  and we assume for P.I. of the form

$$y_p = a + bx + cx^2 + de^{-x}$$

Now,  $y_p' = b + 2cx - de^{-x}$

$$y_p'' = 2c + de^{-2x}$$

We find  $a, b, c, d$  such that

$$y_p'' + 2y_p' + 4y_p = 2x^2 + 3e^{-x}$$

i.e.,  $(2c + de^{-x}) + (2b + 4cx - 2de^{-x}) + (4a + 4bx + 4cx^2 + 4de^{-x}) = 2x^2 + 3e^{-x}$

$$\int (2c + 2b + 4a) + (4c + 4b)x + 4cx^2 + 3de^{-x} = 2x^2 + 3e^{-x}$$

Comparing both sides, we have

$$2c + 2b + 4a = 0 \quad \text{or} \quad 2a + b + c = 0$$

$$4c + 4b = 0 \quad \text{or} \quad b + c = 0$$

$$4c = 2 \quad \therefore \quad c = \frac{1}{2}$$

$$3d = 3 \quad \therefore \quad d = 1$$

Hence, we also obtain  $a = 0, b = \frac{-1}{2}$  using the values of  $a, b, c, d$  in (1), we have

$$y_p = \frac{-1}{2}x + \frac{1}{2}x^2 + e^{-x}$$

$\therefore$  The complete solution is

$$y = \text{C.F.} + y_p$$

$$= e^{-x} \left\{ C_1 \cos(\sqrt{3}x) + C_2 \sin(\sqrt{3}x) \right\} + \frac{x}{2}(x-1) + e^{-x}.$$

12. Using the method of undetermined coefficients solve  $\frac{d^2y}{dx^2} - 2\frac{dy}{dx} + 3y = x^2 + \cos x$ .

**Solution.** We have

$$(D^2 - 2D + 3)y = x^2 + \cos x$$

A.E. is  $m^2 - 2m + 3 = 0$

$$\therefore m = \frac{2 \pm \sqrt{4 - 12}}{2} = \frac{2 \pm \sqrt{-8}}{2} = 1 \pm i\sqrt{2}$$

$$\therefore \text{C.F.} = e^{-x}(C_1 \cos \sqrt{2}x + C_2 \sin \sqrt{2}x)$$

$\phi(x) = x^2 + \cos x$  and we assume for P.I. in the form

$$y_p = a + bx + cx^2 + d \cos x + e \sin x \quad \dots(1)$$

We have to find  $a, b, c, d, e$  such that

$$y_p'' - 2y_p' + 3y_p = x^2 \cos x \quad \dots(2)$$

From (1), we obtain

$$y_p' = b + 2cx - d \sin x + e \cos x$$

$$y_p'' = 2c - d \cos x - e \sin x$$

Hence (2) becomes,

$$(2c - d \cos x - e \sin x) - (2b + 4cx - 2d \sin x + 2e \cos x) + (3a + 3bx + 3cx^2 + 3d \cos x + 3e \sin x) = x^2 + \cos x$$

Comparing both sides, we obtain

$$2c - 2b + 3a = 0 \quad \dots(3)$$

$$-4c + 3b = 0 \quad \dots(4)$$

$$3c = 1 \quad \dots(5)$$

$$2d - 2e = 1 \quad \dots(6)$$

$$2d + 2e = 0 \quad \dots(7)$$

Solving these equations, we get

$$c = \frac{1}{3}, \quad d = \frac{1}{4}, \quad e = \frac{-1}{4}, \quad a = \frac{2}{27}, \quad b = \frac{4}{9}.$$

Substituting these values in (1), we get

$$y_p = \frac{2}{27} + \frac{4}{9}x + \frac{1}{3}x^2 + \frac{1}{4}\cos x - \frac{1}{4}\sin x$$

$\therefore$  The complete solution is

$$y = \text{C.F.} + \text{P.I.}$$

$$y = e^{-x}(C_1 \cos \sqrt{2}x + C_2 \sin \sqrt{2}x) + \frac{1}{27}(2 + 12x + 9x^2) + \frac{1}{4}(\cos x - \sin x).$$

### OBJECTIVE QUESTIONS

1. The solution of a differential equation which is not obtained from the general solution is known as
- (a) Particular solution (b) Singular solution  
(c) Complete solution (d) Auxiliary solution [Ans. b]
2. The differential equation formed by  $y = a \cos x + b \sin x + 4$  where  $a$  and  $b$  are arbitrary constants is
- (a)  $\frac{d^2y}{dx^2} + y = 0$  (b)  $\frac{d^2y}{dx^2} - y = 0$   
(c)  $\frac{d^2y}{dx^2} + y = 4$  (d)  $\frac{d^2y}{dx^2} = y + 4$  [Ans. c]
3. The differential equation representing the family given by  $r = a + b \cos \theta$  is
- (a)  $r_3 + r_1 = 0$  (b)  $r_1 = r_2 \cot \theta$   
(c)  $r_2 = r_1 \cot \theta$  (d)  $r_2^2 = r_1^2 \tan^2 \theta$  [Ans. c]
4. The differential equation  $\frac{dy}{dx} = y^2$  is
- (a) Linear (b) Non-linear  
(c) Quasilinear (d) None of these [Ans. b]
5.  $xdx + ydy + zdz = 0$  is the first order differential equation of a
- (a) Sphere (b) Right circular cone  
(c) Cylinder (d) Ellipsoid [Ans. a]
6.  $y = ce^{-\frac{1}{x}} + d$  is a solution of  $\frac{dy}{dx} = \frac{y}{x^2}$ , when
- (a)  $c = 1, d = 0$  (b)  $c = 2, d = 0$   
(c)  $c = 1, d = 1$  (d)  $c = 2, d = 2$  [Ans. b]
7. For the differential equation  $(y + 3x) dx + xdy = 0$ , the particular solution when  $x = 1, y = 3$  is
- (a)  $3y^2 + 2xy = 9$  (b)  $3x^2 + 2y^2 = 21$   
(c)  $3x^2 + 2y = 9$  (d)  $3x^2 + 2xy = 9$  [Ans. d]
8. The expression  $(xdy - ydx)/(x^2 + y^2)$  is equal to
- (a)  $d \tan^{-1} \left( \frac{x}{y} \right)$  (b)  $d \tan^{-1} \left( \frac{y}{x} \right)$   
(c)  $d \left[ \frac{1}{(x^2 + y^2)} \right]$  (d)  $d \cot^{-1} \left( \frac{y}{x} \right)$  [Ans. b]

9. The general solution of an  $n^{\text{th}}$  order differential equation contains  
 (a) At least  $n$  independent constants (b) At most  $n$  independent constants  
 (c) Exactly  $n$  independent constants (d) Exactly  $n$  dependent constants [Ans. c]
10. The particular integral of  $\frac{d^2y}{dx^2} + y = \cos x$  is  
 (a)  $\frac{1}{2} \sin x$  (b)  $\frac{1}{2} \cos x$   
 (c)  $\frac{1}{2} x \cos x$  (d)  $\frac{1}{2} x \sin x$  [Ans. d]
11. The general differential equation  $(D^2 + 1)^2 y = 0$  is  
 (a)  $C_1 \cos x + C_2 \sin x$   
 (b)  $(C_1 + C_2 x) \cos x + (C_3 + C_4 x) \sin x$   
 (c)  $C_1 \cos x + C_2 \sin x + C_3 \cos x + C_4 \sin x$   
 (d)  $(C_1 \cos x + C_2 \sin x) (C_3 \cos x + C_4 \sin x)$  [Ans. b]
12. The particular integral of the differential equation  $(D^2 + D + 1) y = \sin 2x$  is  
 (a)  $\frac{2 \sin 2x + 3 \cos 2x}{13}$  (b)  $\frac{2 \cos 2x + 3 \sin 2x}{-13}$   
 (c)  $\frac{2 \cos 2x + 3 \sin 2x}{-13}$  (d)  $\frac{2 \cos 2x - 3 \sin 2x}{13}$  [Ans. b]
13. The roots of  $\frac{d^4y}{dx^4} + 10 \frac{d^2y}{dx^2} + 25y = 0$  is  
 (a)  $\pm i\sqrt{5}$  (b)  $\sqrt{5}$   
 (c)  $\pm \sqrt{10}$  (d)  $+\sqrt{5}, -\sqrt{5}$  [Ans. d]
14. The particular integral of  $(D^2 - 4) y = \sin 2x$  is  
 (a)  $\frac{x}{2} \sin 2x$  (b)  $\frac{-x}{4} \cos 2x$   
 (c)  $\frac{x}{2} \cos 2x$  (d) None of these [Ans. d]
15. The particular integral of  $(D^3 + 2D^2 + D) y = e^{2x}$  is  
 (a)  $\frac{1}{18} e^x$  (b)  $\frac{1}{9} e^{2x}$   
 (c)  $\frac{1}{18} e^{2x}$  (d)  $\frac{e^{2x}}{3}$  [Ans. c]
16. The particular integral of  $(D^2 - 2D + 1) y = x^2$  is  
 (a)  $x^2 + 4x + 6$  (b)  $x^3 + 4x^2 + 6$   
 (c)  $x^2 - 4x - 6$  (d) None of these [Ans. a]

17. The complementary function of  $\frac{d^2y}{dx^2} + 4y = 5$  is

(a)  $C_1 \sin 2x + C_2 \sin 3x$

(b)  $C_1 \cos 2x + C_2 \sin 2x$

(c)  $C_1 \cos 2x - C_2 \sin 2x$

(d) None of these

[Ans. b]

18. By the method of undetermined coefficients  $y'' + 3y' + 2y = 12x^2$ , the  $y_p$  is

(a)  $a + bx + cx^2$

(b)  $a + bx$

(c)  $ax + bx^2 + cx^3$

(d) None of these

[Ans. a]

19. The particular integral of  $x'''(t) - 8x(t) = 1$  is

(a)  $\frac{1}{8}$

(b)  $\frac{1}{4}$

(c)  $\frac{-1}{8}$

(d)  $\frac{1}{10}$

[Ans. c]

20. The particular integral of  $\frac{d^2y}{dx^2} + 9y = \cos 3x$  is

(a)  $\frac{\cos x}{8}$

(b)  $\frac{\cos x}{16}$

(c)  $\frac{\cos 3x}{9}$

(d) None of these

[Ans. b]

□□□



## ***Differential Equations-II***

---

### **6.1 METHOD OF VARIATION OF PARAMETERS**

Consider a linear differential equation of second order

$$\frac{d^2y}{dx^2} + a_1 \frac{dy}{dx} + a_2 y = \phi(x) \quad \dots(1)$$

where  $a_1, a_2$  are functions of 'x'. If the complimentary function of this equation is known then we can find the particular integral by using the method known as the method of variation of parameters.

Suppose the complimentary function of the Eqn. (1) is

C.F. =  $C_1 y_1 + C_2 y_2$  where  $C_1$  and  $C_2$  are constants and  $y_1$  and  $y_2$  are the complementary solutions of Eqn. (1)

The Eqn. (1) implies that

$$y_1'' + a_1 y_1' + a_2 y_1 = 0 \quad \dots(2)$$

$$y_2'' + a_1 y_2' + a_2 y_2 = 0 \quad \dots(3)$$

We replace the arbitrary constants  $C_1, C_2$  present in C.F. by functions of  $x$ , say  $A, B$  respectively,

$$\therefore y = Ay_1 + By_2 \quad \dots(4)$$

is the complete solution of the given equation.

The procedure to determine  $A$  and  $B$  is as follows.

From Eqn. (4)  $y' = (Ay_1' + By_2') + (A'y_1 + B'y_2) \quad \dots(5)$

We shall choose  $A$  and  $B$  such that

$$A'y_1 + B'y_2 = 0 \quad \dots(6)$$

Thus Eqn. (5) becomes  $y_1' = Ay_1' + By_2' \quad \dots(7)$

Differentiating Eqn. (7) w.r.t. 'x' again, we have

$$y'' = (Ay_1'' + Ay_2'') + (A'y_1' + B'y_2') \quad \dots(8)$$

Thus, Eqn. (1) as a consequence of (4), (7) and (8) becomes

$$A'y_1' + B'y_2' = \phi(x) \quad \dots(9)$$

Let us consider equations (6) and (9) for solving

$$A'y_1 + B'y_2 = 0 \quad \dots(6)$$

$$A'y_1' + B'y_2' = \phi(x) \quad \dots(9)$$

Solving  $A'$  and  $B'$  by cross multiplication, we get

$$A' = \frac{-y_2 \phi(x)}{W}, B' = \frac{y_1 \phi(x)}{W} \quad \dots(10)$$

Find  $A$  and  $B$

Integrating, 
$$A = -\int \frac{y_2 \phi(x)}{W} dx + k_1$$

$$B = \int \frac{y_1 \phi(x)}{W} dx + k_2$$

where  $W = \begin{vmatrix} y_1 & y_2 \\ y_1' & y_2' \end{vmatrix} = y_1 y_2' - y_2 y_1'$

Substituting the expressions of  $A$  and  $B$

$$y = Ay_1 + By_2 \text{ is the complete solution.}$$

## WORKED OUT EXAMPLES

1. Solve by the method of variation of parameters

$$\frac{d^2 y}{dx^2} + y = \operatorname{cosec} x.$$

**Solution.** We have

$$(D^2 + 1) y = \operatorname{cosec} x$$

A.E. is  $m^2 + 1 = 0 \Rightarrow m^2 = -1 \Rightarrow m = \pm i$

Hence the C.F. is given by

$$\therefore y_c = C_1 \cos x + C_2 \sin x \quad \dots(1)$$

$$y = A \cos x + B \sin x \quad \dots(2)$$

be the complete solution of the given equation where  $A$  and  $B$  are to be found.

The general solution is  $y = Ay_1 + By_2$

We have  $y_1 = \cos x$  and  $y_2 = \sin x$

$$y_1' = -\sin x \text{ and } y_2' = \cos x$$

$$\begin{aligned} W &= y_1 y_2' - y_2 y_1' \\ &= \cos x \cdot \cos x + \sin x \cdot \sin x = \cos^2 x + \sin^2 x = 1 \end{aligned}$$

$$\begin{aligned}
 A' &= \frac{-y_2 \phi(x)}{W}, & B' &= \frac{y_1 \phi(x)}{W} \\
 &= \frac{-\sin x \cdot \operatorname{cosec} x}{1}, & B' &= \frac{\cos x \cdot \operatorname{cosec} x}{1} \\
 &= -\sin x \cdot \frac{1}{\sin x}, & B' &= \cos x \cdot \frac{1}{\sin x} \\
 A' &= -1, & B' &= \cot x
 \end{aligned}$$

On integrating, we get

$$\begin{aligned}
 A &= \int (-1) dx + C_1, \text{ i.e., } A = -x + C_1 \\
 B &= \int \cot x dx + C_2, \text{ i.e., } B = \log \sin x + C_2
 \end{aligned}$$

Hence the general solution of the given Eqn. (2) is

$$\begin{aligned}
 y &= (-x + C_1) \cos x + (\log \sin x + C_2) \sin x \\
 \text{i.e.,} & \quad y = C_1 \cos x + C_2 \sin x - x \cos x + \sin x \log \sin x.
 \end{aligned}$$

2. Solve by the method of variation of parameters

$$\frac{d^2 y}{dx^2} + 4y = 4 \tan 2x.$$

**Solution.** We have

$$(D^2 + 4)y = 4 \tan 2x$$

$$\text{A.E. is} \quad m^2 + 4 = 0$$

where  $\phi(x) = 4 \tan 2x$ .

$$\text{i.e.,} \quad m^2 = -4$$

$$\text{i.e.,} \quad m = \pm 2i$$

Hence the complementary function is given by

$$\begin{aligned}
 y_c &= C_1 \cos 2x + C_2 \sin 2x \\
 y &= A \cos 2x + B \sin 2x \quad \dots(1)
 \end{aligned}$$

be the complete solution of the given equation where  $A$  and  $B$  are to be found

$$\text{We have} \quad y_1 = \cos 2x \quad \text{and} \quad y_2 = \sin 2x$$

$$y_1' = -2 \sin 2x \quad \text{and} \quad y_2' = 2 \cos 2x$$

$$\begin{aligned}
 \text{Then} \quad W &= y_1 y_2' - y_2 y_1' \\
 &= \cos 2x \cdot 2 \cos 2x + 2 \sin 2x \cdot \sin 2x \\
 &= 2 (\cos^2 2x + \sin^2 2x) \\
 &= 2
 \end{aligned}$$

$$\text{Also,} \quad \phi(x) = 4 \tan 2x$$

$$A' = \frac{-y_2 \phi(x)}{W} \quad \text{and} \quad B' = \frac{y_1 \phi(x)}{W}$$

$$A' = \frac{-\sin 2x \cdot 4 \tan 2x}{2}, \quad B' = \frac{-\cos 2x \cdot 4 \tan 2x}{2}$$

$$A' = \frac{-2 \sin^2 2x}{\cos 2x}, \quad B' = 2 \sin 2x$$

On integrating, we get

$$\begin{aligned} A &= -2 \int \frac{\sin^2 2x}{\cos 2x} dx, \quad B = 2 \int \sin 2x dx \\ &= -2 \int \frac{1 - \cos^2 2x}{\cos 2x} dx \\ &= -2 \int \{\sec 2x - \cos 2x\} dx \\ &= -2 \left\{ \frac{1}{2} \log (\sec 2x + \tan 2x) - \frac{1}{2} \sin 2x \right\} \end{aligned}$$

$$A = -\log (\sec 2x + \tan 2x) + \sin 2x + C_1$$

$$\begin{aligned} B &= 2 \int \sin 2x dx \\ &= \frac{2(-\cos 2x)}{2} + C_2 \end{aligned}$$

$$B = -\cos 2x + C_2$$

Substituting these values of  $A$  and  $B$  in Eqn. (1), we get

$$y = C_1 \cos 2x + C_2 \sin 2x - \cos 2x \log (\sec 2x + \tan 2x)$$

which is the required general solution.

3. Solve by the method of variation of parameters

$$\frac{d^2 y}{dx^2} + a^2 y = \sec ax.$$

**Solution.** We have

$$(D^2 + a^2) y = \sec ax$$

$$\text{A.E. is } m^2 + a^2 = 0 \quad \Rightarrow m = \pm ai$$

$$\text{C.F.} = y_c = C_1 \cos ax + C_2 \sin ax$$

$$y = A \cos ax + B \sin ax \quad \dots(1)$$

be the complete solution of the given equation where  $A$  and  $B$  are to be found.

We have,

$$y_1 = \cos ax, \quad y_2 = \sin ax$$

$$y_1' = -a \sin ax, \quad y_2' = a \cos ax$$

$$W = y_1 y_2' - y_2 y_1' = a. \text{ Also, } \phi(x) = \sec ax$$

$$A' = \frac{-y_2 \phi(x)}{W}, \quad \text{and} \quad B' = \frac{y_1 \phi(x)}{W}$$

$$A' = \frac{-\sin ax \cdot \sec ax}{a}, \quad B' = \frac{\cos ax \cdot \sec ax}{a}$$

$$A' = \frac{-\tan ax}{a}, \quad B' = \frac{1}{a}$$

$$B = \frac{1}{a} \int dx + c_2$$

$$A = -\frac{1}{a} \int \tan ax \, dx + C_1, \quad B = \frac{x}{a} + C_2$$

$$A = \frac{-\log(\sec ax)}{a^2} + C_1$$

Substituting these values of  $A$  and  $B$  in Eqn. (1), we get

Thus, 
$$y = C_1 \cos ax + C_2 \sin ax - \frac{\cos ax \log(\sec ax)}{a^2} + \frac{x \sin ax}{a}.$$

4. Solve by the method of variation of parameters

$$\frac{d^2 y}{dx^2} + 2 \frac{dy}{dx} + 2y = e^{-x} \sec^3 x.$$

**Solution.** We have

$$(D^2 + 2D + 2) y = e^{-x} \sec^3 x$$

A.E. is 
$$m^2 + 2m + 2 = 0$$

i.e., 
$$m = \frac{-2 \pm \sqrt{4-8}}{2}$$

$$m = -1 \pm i$$

∴ The complementary function (C.F.) is

$$\text{C.F.} = y_c = e^{-x}(C_1 \cos x + C_2 \sin x)$$

∴ 
$$y = C_1 e^{-x} \cos x + C_2 e^{-x} \sin x$$

⇒ 
$$y = A e^{-x} \cos x + B e^{-x} \sin x \quad \dots(1)$$

Thus 
$$y_1 = e^{-x} \cos x \text{ and } y_2 = e^{-x} \sin x$$

$$y_1' = -e^{-x}(\sin x + \cos x) \quad y_2' = e^{-x}(\cos x - \sin x)$$

$$W = y_1 y_2' - y_2 y_1' = e^{-2x}$$

Also, 
$$\phi(x) = e^{-x} \sec^3 x$$

$$A' = \frac{-y_2 \phi(x)}{W}, \quad B' = \frac{-y_1 \phi(x)}{W}$$

$$= \frac{-e^{-x} \sin x \cdot e^{-x} \sec^3 x}{e^{-2x}} = -\tan x \sec^2 x$$

$$A = -\int \tan x \sec^2 x \, dx$$

$$A = -\frac{1}{2} \tan^2 x + C_1$$

and

$$B' = \frac{y_1 \phi(x)}{W}$$

$$= \frac{e^{-x} \cos x \cdot e^{-x} \sec^3 x}{e^{-2x}}$$

$$B' = \sec^2 x$$

$$B = \int \sec^2 x dx$$

$$B = \tan x + C_2$$

Substituting these values of  $A$  and  $B$  in Eqn. (1), we get

$$\begin{aligned} y &= \left\{ \frac{-1}{2} \tan^2 x + C_1 \right\} e^{-x} \cos x + \{ \tan x + C_2 \} e^{-x} \sin x \\ &= e^{-x} (C_1 \cos x + C_2 \sin x) + \frac{1}{2} e^{-x} \sin^2 x \sec x \end{aligned}$$

This is general solution of the given solution.

5. Solve by the method of variation of parameters

$$\frac{d^2 y}{dx^2} - y = \frac{2}{1+e^x}.$$

**Solution.** We have

$$(D^2 - 1) y = \frac{2}{1+e^x}$$

A.E. is

$$m^2 - 1 = 0$$

i.e.,

$$m^2 = 1 \quad \Rightarrow m = \pm 1$$

Hence C.F. is

$$y_c = C_1 e^x + C_2 e^{-x}$$

$$y = Ae^x + Be^{-x}$$

...(1)

be the complete solution of the given equation where  $A$  and  $B$  are to be found

We have

$$y_1 = e^x$$

and

$$y_2 = e^{-x}$$

$$y_1' = e^x$$

$$y_2' = -e^{-x}$$

$$W = y_1 y_2' - y_2 y_1' \quad \text{also} \quad \phi(x) = \frac{2}{1+e^x}$$

$$= e^x (-e^{-x}) - e^{-x} - e^{-x}$$

$$= -1 - 1 = -2$$

$$\left[ \begin{array}{l} e^{x-x} = e^0 = 1 \\ e^{-x+x} = e^0 = 1 \end{array} \right]$$

$$A' = \frac{-y_2 \phi(x)}{W}$$

$$= \frac{-e^{-x} \cdot \frac{2}{1+e^x}}{-2} = + \frac{e^{-x}}{1+e^x} = \frac{1}{e^x (1+e^x)}$$

$$A' = \frac{1}{e^x (1+e^x)}$$

$$A = \int \frac{1}{e^x (1+e^x)} dx + C_1$$

Substitute  $e^x = t$ , then  $e^x dx = dt$

$$dx = \frac{dt}{t}$$

Hence,

$$A = \int \frac{1}{t^2(1+t)} dt + C_1$$

$$= \int \left[ \frac{1}{t^2} - \frac{1}{t} + \frac{1}{1+t} \right] dt + C_1, \text{ using partial fractions.}$$

$$= -\frac{1}{t} - \log t + \log(1+t) + C_1$$

$$A = -e^{-x} - x + \log(1 + e^x) + C_1$$

$$B' = \frac{y_1 \phi(x)}{W}$$

$$= \frac{e^x \cdot \frac{2}{1+e^x}}{-2} = -\frac{e^x}{1+e^x}$$

$$B = -\int \frac{e^x}{1+e^x} dx + C_2$$

$$B = -\log(1 + e^x) + C_2$$

Substituting these values of  $A$  and  $B$  in eqn. (1), we get

$$y = \left[ -e^{-x} - x + \log(1 + e^x) + C_1 \right] e^x + \left[ -\log(1 + e^x) + C_2 \right] e^{-x}$$

$$= C_1 e^x + C_2 e^{-x} - 1 - x e^x + e^x \log(1 + e^x) - e^{-x} \log(1 + e^x)$$

$$= C_1 e^x + C_2 e^{-x} - 1 - x e^x + (e^x - e^{-x}) \log(1 + e^x)$$

This is the complete solution of the given equation.

### 6. Solve by the method of variation of parameters

$$y'' + y = \tan x.$$

**Solution.** We have  $(D^2 + 1)y = \tan x$

A.E. is  $m^2 + 1 = 0$

i.e.,  $m^2 = -1$

i.e.,  $m = \pm i$

C.F. is C.F. =  $y_c = C_1 \cos x + C_2 \sin x$

$\therefore y = A \cos x + B \sin x$  ...(1)

be the complete solution of the given equation where  $A$  and  $B$  are to be found

We have  $y_1 = \cos x$  and  $y_2 = \sin x$

$$y_1' = -\sin x \quad y_2' = \cos x$$

$$W = y_1 y_2' - y_2 y_1'$$

$$= \cos x \cdot \cos x + \sin x \cdot \sin x = \cos^2 x + \sin^2 x = 1$$

Also,

$$\phi(x) = \tan x$$

$$A' = \frac{-y_2 \phi(x)}{W}$$

$$= \frac{-\sin x \cdot \tan x}{1}$$

$$A' = \frac{-\sin^2 x}{\cos x}$$

$$A = -\int \frac{\sin^2 x}{\cos x} dx + C_1$$

$$= -\int \frac{1 - \cos^2 x}{\cos x} dx + C_1$$

$$= -\int (\sec x - \cos x) dx + C_1$$

$$A = -[\log(\sec x + \tan x) - \sin x] + C_1$$

$$B' = \frac{y_1 \phi(x)}{W}$$

$$= \frac{\cos x \cdot \tan x}{1}$$

$$B' = \sin x$$

$$B = \int \sin x dx + C_2$$

$$B = -\cos x + C_2$$

Substitute these values of  $A$  and  $B$  in Eqn. (1), we get

$$y = \{-\log(\sec x + \tan x) + \sin x + C_1\} \cos x + \{-\cos x + C_2\} \sin x$$

$$y = C_1 \cos x + C_2 \sin x - \cos x \log(\sec x + \tan x)$$

This is the complete solution.

7. Solve by the method of variation of parameters

$$\frac{d^2 y}{dx^2} - 2 \frac{dy}{dx} + 2y = e^x \tan x.$$

**Solution.** We have  $(D^2 - 2D + 2)y = e^x \tan x$

A.E. is  $m^2 - 2m + 2 = 0$

i.e.,  $m = \frac{2 \pm \sqrt{4 - 8}}{2}$

$$m = 1 \pm i$$

Therefore C.F. is

$$y_c = e^x (C_1 \cos x + C_2 \sin x)$$

$$\therefore y = e^x (A \cos x + B \sin x) \quad \dots(1)$$

be the complete solution of the given equation



where  $A$  and  $B$  are to be found

We have  $y_1 = e^x \cos x$  and  $y_2 = e^x \sin x$

$$y_1' = e^x (\cos x - \sin x), \quad y_2' = e^x (\sin x + \cos x)$$

$$W = y_1 y_2' - y_2 y_1' = e^{2x} \quad \text{Also, } \phi(x) = e^x \tan x$$

$$A' = \frac{-y_2 \phi(x)}{W} \\ = \frac{-e^x \sin x \cdot e^x \tan x}{e^{2x}}$$

$$A' = \frac{-\sin^2 x}{\cos x}$$

$$A = -\int \frac{\sin^2 x}{\cos x} dx = -\int \frac{1 - \cos^2 x}{\cos x} dx$$

$$= -\int (\sec x - \cos x) dx$$

$$A = -\log (\sec x + \tan x) + \sin x + C_1$$

$$B' = \frac{y_1 \cdot \phi(x)}{W} \\ = \frac{e^x \cos x \cdot e^x \tan x}{e^{2x}}$$

$$B' = \sin x$$

$$B = \int \sin x dx + C_2$$

$$B = -\cos x + C_2$$

Substituting these values of  $A$  and  $B$  in Eqn. (1), we get

$$y = \{-\log (\sec x + \tan x) + \sin x + C_1\} e^x \cos x + \{-\cos x + C_2\} e^x \sin x$$

$$y = e^x (C_1 \cos x + C_2 \sin x) - e^x \cos x \log (\sec x + \tan x)$$

This is the complete solution of the given equation.

**8. Solve by the method of variation of parameters**

$$\frac{d^2 y}{dx^2} - 2 \frac{dy}{dx} + y = e^x \log x.$$

**Solution.** We have  $(D^2 - 2D + 1) y = e^x \log x$

A.E. is  $m^2 - 2m + 1 = 0$

i.e.,  $(m - 1)^2 = 0$

i.e.,  $m = 1, 1$

Hence C.F. is

$$y_c = (C_1 + C_2 x) e^x = C_1 e^x + C_2 x e^x$$

$$\therefore y = Ae^x + Bxe^x \quad \dots(1)$$

We have

$$y_1 = e^x \text{ and } y_2 = xe^x$$

$$y_1' = e^x, \quad y_2' = xe^x + e^x$$

$$W = y_1 y_2' - y_2 y_1' = xe^{2x} + e^{2x} - xe^{2x} = e^{2x}$$

Also

$$\phi(x) = e^x \log x$$

$$A' = \frac{-y_2 \phi(x)}{W}, \quad B' = \frac{-y_1 \phi(x)}{W}$$

$$= \frac{-xe^x \cdot e^x \log x}{e^{2x}} = \frac{e^x \cdot e^x \log x}{e^{2x}}$$

$$A' = -x \cdot \log x,$$

$$B' = \log x$$

$$A = -\int \log x \cdot x \, dx$$

Integrating both these terms by parts, we get

$$A = -\left[ \log x \cdot \frac{x^2}{2} - \int \frac{x^2}{2} \cdot \frac{1}{x} \, dx \right] + C_1 \quad B = \log x \cdot x - \int x \cdot \frac{1}{x} \, dx + C_2$$

$$A = \frac{-x^2 \log x}{2} + \frac{x^2}{4} + C_1, \quad B = x \log x - x + C_2$$

Substituting these values of  $A$  and  $B$  in Eqn. (1), we get

$$y = \left\{ \frac{-x^2 \log x}{2} + \frac{x^2}{4} + C_1 \right\} e^x + (x \log x - x + C_2) x e^x$$

$$y = (C_1 + C_2 x) e^x - \frac{x^2 e^x \log x}{2} + \frac{x^2 e^x}{4} + x^2 \log x e^x - x^2 e^x$$

$$= (C_1 + C_2 x) e^x + \frac{x^2 \log x \cdot e^x}{2} - \frac{3}{4} x^2 e^x$$

Thus,

$$y = (C_1 + C_2 x) e^x + \frac{x^2 e^x}{4} (2 \log x - 3).$$

**9. Solve by the method of variation of parameters**

$$y'' + 4y' + 4y = 4 + \frac{e^{-2x}}{x}.$$

**Solution.** We have  $(D^2 + 4D + 4)y = 4 + \frac{e^{-2x}}{x}$

A.E. is  $m^2 + 4m + 4 = 0$

i.e.,  $(m + 2)^2 = 0$

$$m = -2, -2$$

C.F. is  $y_c = e^{-2x} (C_1 + C_2 x)$

$$y = C_1 e^{-2x} + C_2 x e^{-2x}$$

$$\therefore y = A e^{-2x} + B x e^{-2x} \quad \dots(1)$$

be the complete solution of the given equation where  $A$  and  $B$  are to be found

$$\begin{aligned} \text{We have } y_1 &= e^{-2x} & \text{and } y_2 &= x e^{-2x} \\ y_1' &= -2e^{-2x} & y_2' &= e^{-2x} (1 - 2x) \end{aligned}$$

$$\begin{aligned} W &= y_1 y_2' - y_2 y_1' \\ &= e^{-2x} \cdot e^{-2x} (1 - 2x) + x e^{-2x} \cdot 2 \cdot e^{-2x} \end{aligned}$$

$$W = e^{-4x} \quad \text{Also, } \phi(x) = 4 + \frac{e^{-2x}}{x}$$

$$\begin{aligned} A' &= \frac{-y_2 \phi(x)}{W} & B' &= \frac{-y_1 \phi(x)}{W} \\ &= \frac{-x e^{-2x} \cdot \left(4 + \frac{e^{-2x}}{x}\right)}{e^{-4x}} & &= \frac{e^{-2x} \cdot \left(4 + \frac{e^{-2x}}{x}\right)}{e^{-4x}} \end{aligned}$$

$$A' = -(4x e^{2x} + 1), \quad B' = e^{2x} \left(4 + \frac{e^{-2x}}{x}\right)$$

On integrating, we get

$$A = -\int (4x e^{2x} + 1) dx + C_1, \quad B = \int e^{2x} \left(4 + \frac{e^{-2x}}{x}\right) dx + C_2$$

$$A = -\left[4x \cdot \frac{e^{2x}}{2} - 4 \cdot \frac{e^{2x}}{4}\right] - x + C_1, \quad = \int \left(4e^{2x} + \frac{1}{x}\right) dx + C_2$$

$$A = -2x e^{2x} + e^{2x} - x + C_1 \quad B = 2e^{2x} + \log x + C_2$$

Substituting these values of  $A$  and  $B$  in Eqn. (1), we get

$$\begin{aligned} y &= (-2x e^{2x} + e^{2x} - x + C_1) e^{-2x} + (2e^{2x} + \log x + C_2) x e^{-2x} \\ &= (C_1 + C_2 x) e^{-2x} - 2x + 1 - x e^{-2x} + 2x + x e^{-2x} \log x \\ y &= (C_1 + C_2 x) e^{-2x} + 1 + x e^{-2x} (\log x - 1). \end{aligned}$$

**10. Solve by the method of variation of parameters**

$$y'' + 2y' + 2y = e^{-x} \sec^3 x.$$

**Solution.** We have  $(D^2 + 2D + 2)y = e^{-x} \sec^3 x$

$$\text{A.E. is } m^2 + 2m + 2 = 0$$

$$\text{i.e., } m = \frac{-2 \pm \sqrt{4 - 8}}{2} = -1 \pm i$$

$$\therefore \text{C.F. is } y_c = e^{-x} (C_1 \cos x + C_2 \sin x)$$

$$\therefore y = A e^{-x} \cos x + B e^{-x} \sin x \quad \dots(1)$$

be the complete solution of the given equation where  $A$  and  $B$  are functions of  $x$  to be found

We have  $y_1 = e^{-x} \cos x$  and  $y_2 = e^{-x} \sin x$   
 $y_1' = -e^{-x} (\sin x + \cos x)$   $y_2' = e^{-x} (\cos x - \sin x)$   
 $W = y_1 y_2' - y_2 y_1'$   
 $= e^{-2x}$

Also,  $\phi(x) = e^{-x} \sec^3 x$   
 $A' = \frac{-y_2 \phi(x)}{W}$   $B' = \frac{-y_1 \phi(x)}{W}$   
 $A' = \frac{-e^{-x} \sin x \cdot e^{-x} \sec^3 x}{e^{-2x}}$   $B' = \frac{e^{-x} \cos x \cdot e^{-x} \sec^3 x}{e^{-2x}}$   
 $A' = -\tan x \sec^2 x$   $B' = \sec^2 x$   
 $A = -\int \tan x \sec^2 x dx + C_1$ ,  
 $A = -\frac{\tan^2 x}{2} + C_1$ ,  $B = \int \sec^2 x dx + C_2$   
 $B = \tan x + C_2$

Substituting these values of  $A$  and  $B$  in Eqn. (1), we get

$$y = \left( -\frac{\tan^2 x}{2} + C_1 \right) e^{-x} \cos x + (\tan x + C_2) e^{-x} \sin x$$

$$= e^{-x} (C_1 \cos x + C_2 \sin x) - \frac{e^{-x} \tan x \sin x}{2} + e^{-x} \tan x \sin x$$

Thus,

$$y = e^{-x} (C_1 \cos x + C_2 \sin x) + \frac{e^{-x} \tan x \sin x}{2}$$

This is complete solution of the given equation.

## EXERCISE 6.1

Solve the following equations by the method of variation of parameters:

1.  $\frac{d^2 y}{dx^2} + y = \tan^2 x$ . [Ans.  $y = C_1 \cos x + C_2 \sin x + \sin x \log (\sec x + \tan x) - 2$ ]

2.  $\frac{d^2 y}{dx^2} + y = x \sin x$ . [Ans.  $y = C_1 \cos x + C_2 \sin x + \frac{1}{2} x \sin x - \frac{1}{4} x^2 \cos x$ ]

3.  $\frac{d^2 y}{dx^2} - 5 \frac{dy}{dx} + 6y = e^{4x}$ . [Ans.  $y = C_1 e^{2x} + C_2 e^{3x} + \frac{1}{2} e^{4x}$ ]

4.  $\frac{d^2 y}{dx^2} + 4y = 4 \sec^2 2x$ . [Ans.  $y = C_1 \cos 2x + C_2 \sin 2x + \sin 2x \log (\sec 2x + \tan 2x) - 1$ ]

5.  $(D^2 + D)y = x \cos x$ . [Ans.  $y = C_1 + C_2 e^{-x} + \frac{1}{2} x (\sin x - \cos x) + \cos x + 2 \sin x$ ]

$$6. (D^2 + a^2) y = \operatorname{cosec} ax. \quad \left[ \text{Ans. } y = C_1 \cos ax + C_2 \sin ax - \frac{1}{a} x \cos ax + \frac{1}{a^2} \sin ax \log \sin ax \right]$$

$$7. (D^2 + 1) y = \sec x \tan x. \quad \left[ \text{Ans. } y = C_1 \cos x + C_2 \sin x + x \cos x - \sin x + \sin x \log \sec x \right]$$

$$8. (D^2 + 2D + 1) y = e^{-x} \log x. \quad \left[ \text{Ans. } y = (C_1 + C_2 x) e^{-x} + \frac{1}{4} x^2 e^{-x} (2 \log x - 3) \right]$$

$$9. (D^2 - 3D + 2) y = \frac{1}{1 + e^{-x}}. \quad \left[ \text{Ans. } y = C_1 e^x + C_2 e^{2x} - x e^x + e^x \log(1 + e^x) + e^{2x} \log(1 + e^{-x}) \right]$$

$$10. (D^2 - 6D + 9) y = \frac{e^{3x}}{x^2}. \quad \left[ \text{Ans. } y = (C_1 + C_2 x) e^{3x} - e^{3x} \log x \right]$$

$$11. (D^2 - 2D + 1) y = x^2 e^{3x}. \quad \left[ \text{Ans. } y = (C_1 + C_2 x) e^{3x} + \frac{1}{8} (2x^2 - 4x + 3) e^{3x} \right]$$

$$12. (D^2 + 1) y = \log \cos x. \quad \left[ \text{Ans. } y = C_1 \cos x + C_2 \sin x + \sin x \log(\sec x + \tan x) + \log \cos x - 1 \right]$$

$$13. (D^2 + 1) y = \frac{1}{1 + \sin x}. \quad \left[ \text{Ans. } y = C_1 \cos x + C_2 \sin x - x \cos x + \sin x \log(1 + \sin x) - 1 \right]$$

$$14. (D^2 - 2D + 1) y = \frac{e^x}{x}. \quad \left[ \text{Ans. } y = (C_1 + C_2 x) e^x + x e^x \log x \right]$$

$$15. (D^2 + 6D + 9) y = \frac{e^{-3x}}{x^5}. \quad \left[ \text{Ans. } y = (C_1 + C_2 x) e^{-3x} + \frac{1}{12} x^{-3} e^{-3x} \right]$$

## 6.2 SOLUTION OF CAUCHY'S HOMOGENEOUS LINEAR EQUATION AND LEGENDRE'S LINEAR EQUATION

A linear differential equation of the form

$$x^n \frac{d^n y}{dx^n} + a_1 x^{n-1} \frac{d^{n-1} y}{dx^{n-1}} + a_2 x^{n-2} \frac{d^{n-2} y}{dx^{n-2}} + \dots + a_{n-1} x \frac{dy}{dx} + a_n y = \phi(x) \quad \dots(1)$$

Where  $a_1, a_2, a_3 \dots a_n$  are constants and  $\phi(x)$  is a function of  $x$  is called a homogeneous linear differential equation of order  $n$ .

The equation can be transformed into an equation with constant coefficients by changing the independent variable  $x$  to  $z$  by using the substitution  $x = e^z$  or  $z = \log x$

$$\text{Now} \quad z = \log x \Rightarrow \frac{dz}{dx} = \frac{1}{x}$$

Consider  $\frac{dy}{dx} = \frac{dy}{dz} \cdot \frac{dz}{dx} = \frac{1}{x} \cdot \frac{dy}{dz}$

$\therefore x \frac{dy}{dx} = \frac{dy}{dz} = Dy$

where  $D = \frac{d}{dz}$ .

Differentiating w.r.t. 'x' we get,

$$x \frac{d^2y}{dx^2} + \frac{dy}{dx} \cdot 1 = \frac{d^2y}{dz^2} \cdot \frac{dz}{dx}$$

i.e.,  $x \frac{d^2y}{dx^2} = \frac{d^2y}{dz^2} \cdot \frac{1}{x} - \frac{dy}{dx}$

$$= \frac{1}{x} \cdot \frac{d^2y}{dz^2} - \frac{1}{x} \cdot \frac{dy}{dz}$$

i.e.,  $x^2 \frac{d^2y}{dx^2} = \frac{d^2y}{dz^2} - \frac{dy}{dz}$

i.e.,  $x^2 \frac{d^2y}{dx^2} = (D^2 - D) y = D (D - 1) y$

Similarly,  $x^3 \frac{d^3y}{dx^3} = D (D - 1) (D - 2) y$

.....  
 .....

$$x^n \frac{d^n y}{dx^n} = D (D - 1) \dots (D - n + 1) y$$

Substituting these values of  $x \frac{dy}{dx}, x^2 \frac{d^2y}{dx^2}, \dots, x^n \frac{d^n y}{dx^n}$  in Eqn. (1), it reduces to a linear differential equation with constant coefficient can be solved by the method used earlier.

Also, an equation of the form,

$$(ax + b)^n \cdot \frac{d^n y}{dx^n} + a_1 (ax + b)^{n-1} \cdot \frac{d^{n-1} y}{dx^{n-1}} + \dots any = (x) \tag{2}$$

where  $a_1, a_2, \dots, a_n$  are constants and  $\phi(x)$  is a function of  $x$  is called a homogeneous linear differential equation of order  $n$ . It is also called "Legendre's linear differential equation".

This equation can be reduced to a linear differential equation with constant coefficients by using the substitution.

$$ax + b = e^z \text{ or } z = \log (ax + b)$$

As above we can prove that

$$(ax + b) \cdot \frac{dy}{dx} = a Dy$$

$$(ax + b)^2 \cdot \frac{d^2 y}{dx^2} = a^2 D (D - 1) y$$

.....  
 .....

$$(ax + b)^n \cdot \frac{d^n y}{dx^n} = a^n D (D - 1)(D - 2) \dots (D - n + 1) y$$

The reduced equation can be solved by using the methods of the previous section.

### WORKED OUT EXAMPLES

1. Solve  $x^2 \frac{d^2 y}{dx^2} - 2x \frac{dy}{dx} - 4y = x^4$ .

**Solution.** The given equation is

$$x^2 \frac{d^2 y}{dx^2} - 2x \frac{dy}{dx} - 4y = x^4 \quad \dots(1)$$

Substitute  $x = e^z$  or  $z = \log x$

So that  $x \frac{dy}{dx} = Dy$ ,  $x^2 \frac{d^2 y}{dx^2} = D(D - 1) y$

The given equation reduces to

$$\begin{aligned} D(D - 1) y - 2Dy - 4y &= (e^z)^4 \\ [D(D - 1) - 2D - 4] y &= e^{4z} \\ \text{i.e., } (D^2 - 3D - 4) y &= e^{4z} \quad \dots(2) \end{aligned}$$

which is an equation with constant coefficients

A.E. is  $m^2 - 3m - 4 = 0$

i.e.,  $(m - 4)(m + 1) = 0$

$\therefore m = 4, -1$

C.F. is  $C_1 e^{4z} + C_2 e^{-z}$

P.I. =  $\frac{1}{D^2 - 3D - 4} e^{4z} \quad D \rightarrow 4$

=  $\frac{1}{(4)^2 - 3(4) - 4} e^{4z} \quad Dr = 0$

=  $\frac{1}{2D - 3} z e^{4z} \quad D \rightarrow 4$

=  $\frac{1}{(2)(4) - 3} z e^{4z}$

=  $\frac{1}{5} z e^{4z}$

∴ The general solution of (2) is

$$y = \text{C.F.} + \text{P.I.}$$

$$y = C_1 e^{4z} + C_2 e^{-z} + \frac{1}{5} z e^{4z}$$

Substituting  $e^z = x$  or  $z = \log x$ , we get

$$y = C_1 x^4 + C_2 x^{-1} + \frac{1}{5} \log x (x^4)$$

$$y = C_1 x^4 + \frac{C_2}{x} + \frac{x^4}{5} \log x$$

is the general solution of the Eqn. (1).

2. Solve  $x^2 \frac{d^2 y}{dx^2} - 3x \frac{dy}{dx} + 4y = (x + 1)^2$ .

**Solution.** The given equation is

$$x^2 \frac{d^2 y}{dx^2} - 3x \frac{dy}{dx} + 4y = (x + 1)^2 \quad \dots(1)$$

Substituting  $x = e^z$  or  $z = \log x$

Then  $x \frac{dy}{dx} = Dy, \quad x^2 \frac{d^2 y}{dx^2} = D(D-1)y$

∴ Eqn. (1) reduces to

$$D(D-1)y - 3Dy + 4y = (e^z + 1)^2$$

$$\text{i.e.,} \quad (D^2 - 4D + 4)y = e^{2z} + 2e^z + 1$$

which is a linear equation with constant coefficients.

A.E. is  $m^2 - 4m + 4 = 0$

i.e.,  $(m - 2)^2 = 0$

∴  $m = 2, 2$

C.F. =  $(C_1 + C_2 z) e^{2z}$

$$\text{P.I.} = \frac{1}{(D-2)^2} (e^{2z} + 2e^z + 1) \quad \dots(2)$$

$$= \frac{e^{2z}}{(D-2)^2} + \frac{2e^z}{(D-2)^2} + \frac{e^{0z}}{(D-2)^2}$$

$$= \text{P.I.}_1 + \text{P.I.}_2 + \text{P.I.}_3$$

$$\text{P.I.}_1 = \frac{e^{2z}}{(D-2)^2} \quad (D \rightarrow 2)$$

$$= \frac{e^{2z}}{(2-2)^2} \quad (Dr = 0)$$

$$= \frac{ze^{2z}}{2(D-2)} \quad (D \rightarrow 2)$$



$$= \frac{ze^{2z}}{2(2-2)} \quad (Dr = 0)$$

$$\text{P.I.}_1 = \frac{z^2 e^{2z}}{2}$$

$$\text{P.I.}_2 = \frac{2e^z}{(D-2)^2} \quad (D \rightarrow 1)$$

$$= \frac{2e^z}{(-1)^2}$$

$$\text{P.I.}_2 = 2e^z$$

$$\text{P.I.}_3 = \frac{e^{0z}}{(D-2)^2} \quad (D \rightarrow 0)$$

$$= \frac{e^{0z}}{4} = \frac{1}{4}$$

$$\text{P.I.} = \frac{z^2}{2} e^{2z} + 2e^z + \frac{1}{4}$$

The general solution of Eqn. (2) is

$$y = \text{C.F.} + \text{P.I.}$$

$$y = (C_1 + C_2 z) e^{2z} + \frac{z^2 e^{2z}}{2} + 2e^z + \frac{1}{4}$$

Substituting

$$e^z = x \text{ or } z = \log x, \text{ we get}$$

$$y = (C_1 + C_2 \log x) x^2 + \frac{x^2 (\log x)^2}{2} + 2x + \frac{1}{4}$$

is the general solution of the equation (1).

3. Solve  $x^2 \frac{d^2 y}{dx^2} + 2x \frac{dy}{dx} - 12y = x^2 \log x$ .

**Solution.** The given Eqn. is

$$x^2 \frac{d^2 y}{dx^2} + 2x \frac{dy}{dx} - 12y = x^2 \log x \quad \dots(1)$$

Substituting  $x = e^z$  or  $z = \log x$ , so that

$$x \frac{dy}{dx} = Dy, \quad \text{and} \quad x^2 \frac{d^2 y}{dx^2} = D(D-1)y$$

Then Eqn. (1) reduces to

$$D(D-1)y + 2Dy - 12y = e^{2z}z$$

$$\text{i.e.,} \quad (D^2 + D - 12)y = ze^{2z} \quad \dots(2)$$

which is the Linear differential equation with constant coefficients.

A.E. is  $m^2 + m - 12 = 0$

$$\text{i.e., } (m + 4)(m - 3) = 0$$

$$\therefore m = -4, 3$$

$$\text{C.F.} = C_1 e^{-4z} + C_2 e^{3z}$$

$$\text{P.I.} = \frac{1}{D^2 + D - 12} z e^{2z}$$

$$= e^{2z} \frac{z}{(D+2)^2 + (D+2) - 12} \quad (D \rightarrow D+2)$$

$$= e^{2z} \left[ \frac{z}{D^2 + 5D - 6} \right]$$

$$-\frac{1}{6}z - \frac{5}{36}$$

$$-6 + 5D + D^2 \left| \begin{array}{c} z \\ z - \frac{5}{6} \\ \hline \frac{5}{6} \\ \frac{5}{6} \\ \hline 0 \end{array} \right.$$

$$\text{P.I.} = e^{2z} \left[ -\frac{z}{6} - \frac{5}{36} \right] = \frac{-e^{2z}}{6} \left[ z + \frac{5}{6} \right]$$

$\therefore$  General solution of Eqn. (2) is

$$y = \text{C.F.} + \text{P.I.}$$

$$y = C_1 e^{-4z} + C_2 e^{3z} - \frac{e^{2z}}{6} \left( z + \frac{5}{6} \right)$$

Substituting

$$e^z = x \text{ or } z = \log x, \text{ we get}$$

$$y = C_1 x^{-4} + C_2 x^3 - \frac{x^2}{6} \left( \log x + \frac{5}{6} \right)$$

$$y = \frac{C_1}{x^4} + C_2 x^3 - \frac{x^2}{6} \left( \log x + \frac{5}{6} \right)$$

which is the general solution of Eqn. (1).

4. Solve  $x^2 \frac{d^2 y}{dx^2} - x \frac{dy}{dx} + y = 2 \log x$ .

**Solution.** The given equation is

$$x^2 \frac{d^2 y}{dx^2} - x \frac{dy}{dx} + y = 2 \log x \quad \dots(1)$$

Substitute  $x = e^z$  or  $z = \log x$ , in Eqn. (1)

Then  $x \frac{dy}{dx} = Dy$ , and  $x^2 \frac{d^2y}{dx^2} = D(D-1)y$

Eqn. (1) reduces to,

$$D(D-1)y - Dy + y = 2z$$

$$\text{i.e., } (D^2 - 2D + 1)y = 2z \quad \dots(2)$$

which is an equation with constant coefficients

$$\text{A.E. is } m^2 - 2m + 1 = 0$$

$$\text{i.e., } (m-1)^2 = 0$$

$$\therefore m = 1, 1$$

$$\text{C.F.} = (C_1 + C_2z) e^z$$

$$\text{P.I.} = \frac{1}{D^2 - 2D + 1} \cdot 2z$$

$$1 - 2D + D^2 \begin{array}{|l} 2z + 4 \\ \hline 2z \\ 2z - 4 \\ \hline 4 \\ 4 \\ \hline 0 \end{array}$$

$$\text{P.I.} = 2z + 4$$

$\therefore$  The general solution of Eqn. (2) is

$$y = (C_1 + C_2z) e^z + 2z + 4$$

Hence the general solution of Eqn. (1) is

$$y = (C_1 + C_2 \log x) \cdot x + 2 \log x + 4.$$

5. Solve  $x^2 \frac{d^2y}{dx^2} - 4x \frac{dy}{dx} + 6y = \cos(2 \log x)$ .

**Solution.** The given equation is

$$x^2 \frac{d^2y}{dx^2} - 4x \frac{dy}{dx} + 6y = \cos(2 \log x) \quad \dots(1)$$

Substituting  $x = e^z$  or  $z = \log x$ , we have

$$x \frac{dy}{dx} = Dy, \text{ and } x^2 \frac{d^2y}{dx^2} = D(D-1)y$$

$\therefore$  Eqn. (1) reduces to

$$D(D-1)y - 4Dy + 6y = \cos 2z$$

$$\text{i.e., } (D^2 - 5D + 6)y = \cos 2z \quad \dots(2)$$

$$\text{A.E. is } m^2 - 5m + 6 = 0$$

$$\text{i.e.,} \quad (m - 2)(m - 3) = 0$$

$$\therefore \quad m = 2, 3$$

$$\text{C.F.} = C_1 e^{2z} + C_2 e^{3z}$$

$$\text{P.I.} = \frac{1}{D^2 - 5D + 6} \cos 2z \quad D^2 \rightarrow -2^2$$

$$= \frac{1}{-2^2 - 5D + 6} \cos 2z$$

$$= \frac{1}{-5D + 2} \cos 2z$$

$$= \frac{1}{2 - 5D} \cos 2z \times \frac{2 + 5D}{2 + 5D}$$

$$= \frac{2 \cos 2z - 10 \sin 2z}{4 - 25D^2} \quad D^2 \rightarrow -2^2$$

$$= \frac{2 \cos 2z - 10 \sin 2z}{104}$$

$$\text{P.I.} = \frac{1}{52} (\cos 2z - 5 \sin 2z)$$

The general solution of Eqn. (2) is

$$y = \text{C.F.} + \text{P.I.}$$

$$= C_1 e^{2z} + C_2 e^{3z} + \frac{1}{52} (\cos 2z - 5 \sin 2z)$$

Hence the general solution is

$$y = C_1 x^2 + C_2 x^3 + \frac{1}{52} [\cos(2 \log x) - 5 \sin(2 \log x)].$$

6. Solve  $x^2 \frac{d^2 y}{dx^2} + x \frac{dy}{dx} + 2y = x \cos(\log x)$ .

**Solution.** The given equation is

$$x^2 \frac{d^2 y}{dx^2} + x \frac{dy}{dx} + 2y = x \cos(\log x) \quad \dots(1)$$

Substitute  $x = e^z$  or  $z = \log x$ ,

Then we have  $x \frac{dy}{dx} = Dy$  and  $x^2 \frac{d^2 y}{dx^2} = D(D-1)y$

$\therefore$  Eqn. (1) reduces to

$$D(D-1)y + Dy + 2y = e^z \cos z$$

$$\text{i.e.,} \quad (D^2 + 2)y = e^z \cos z \quad \dots(2)$$

A.E. is  $m^2 + 2 = 0$

*i.e.*,  $m^2 = -2$ ;

i.e.,

$$m^2 = 2i^2 \Rightarrow m = \pm\sqrt{2}i$$

$$\text{C.F.} = C_1 \cos\sqrt{2}z + C_2 \sin\sqrt{2}z$$

$$\text{P.I.} = \frac{1}{D^2 + 2} e^z \cos z \quad (D \rightarrow D + 1)$$

$$= e^z \frac{1}{(D+1)^2 + 2} \cos z$$

$$= e^z \frac{1}{D^2 + 2D + 3} \cos z \quad (D^2 \rightarrow -1^2)$$

$$= e^z \left[ \frac{\cos z}{-1^2 + 2D + 3} \right]$$

$$= e^z \left[ \frac{\cos z}{2D + 2} \right]$$

$$= \frac{e^z}{2} \left[ \frac{\cos z}{D+1} \times \frac{D-1}{D-1} \right]$$

$$= \frac{e^z}{2} \left[ \frac{-\sin z - \cos z}{D^2 - 1} \right] \quad (D^2 \rightarrow -1^2)$$

$$= \frac{e^z}{2} \left[ \frac{-\sin z - \cos z}{-2} \right]$$

$$= \frac{e^z}{4} (\sin z + \cos z)$$

\(\therefore\) General solution of Eqn. (2) is

$$y = \text{C.F.} + \text{P.I.}$$

$$= C_1 \cos\sqrt{2}z + C_2 \sin\sqrt{2}z + \frac{e^z}{4} (\sin z + \cos z)$$

\(\therefore\) The general solution of Eqn. (1), as

$$y = C_1 \cos\sqrt{2} \log x + C_2 \sin\sqrt{2} \log x + \frac{x}{4} [\sin(\log x) + \cos(\log x)].$$

7. Solve  $2x \frac{d^2y}{dx^2} + 3 \frac{dy}{dx} - \frac{y}{x} = 5 - \frac{\sin(\log x)}{x^2}$ .

**Solution.** Multiplying throughout the equation by  $x$ , we get

$$2x^2 \frac{d^2y}{dx^2} + 3x \frac{dy}{dx} - y = 5x - \frac{\sin(\log x)}{x} \quad \dots(1)$$

Substitute

$$x = e^z \text{ or } z = \log x, \text{ in Eqn. (1)}$$

Then we obtain,

$$\{2D(D-1) + 3D - 1\} y = 5e^z - e^{-z} \sin z$$

i.e.,  $(2D^2 + D - 1) y = 5e^z - e^{-z} \sin z$  ... (2)

A.E. is  $2m^2 + m - 1 = 0$

i.e.,  $(m+1)(2m-1) = 0$

$\therefore m = -1, \frac{1}{2}$

$$\text{C.F.} = C_1 e^{-z} + C_2 e^{\left(\frac{1}{2}\right)z}$$

$$\begin{aligned} \text{P.I.} &= \frac{1}{2D^2 + D - 1} (5e^z - e^{-z} \sin z) \\ &= \frac{1}{2D^2 + D - 1} 5e^z - \frac{1}{2D^2 + D - 1} e^{-z} \sin z \\ &= \text{P.I.}_1 - \text{P.I.}_2 \end{aligned}$$

$$\begin{aligned} \text{P.I.}_1 &= \frac{5e^z}{2D^2 + D - 1} && (D \rightarrow 1) \\ &= \frac{5e^z}{2} \end{aligned}$$

$$\text{P.I.}_2 = \frac{1}{2D^2 + D - 1} e^{-z} \sin z \quad (D \rightarrow D - 1)$$

$$\begin{aligned} &= e^{-z} \frac{1}{2(D-1)^2 + (D-1) - 1} \sin z \\ &= e^{-z} \left[ \frac{\sin z}{2D^2 - 3D} \right] && (D^2 \rightarrow -1^2) \end{aligned}$$

$$= e^{-z} \left[ \frac{\sin z}{2(-1^2) - 3D} \right]$$

$$= e^{-z} \frac{\sin z}{-2 - 3D}$$

$$= -e^{-z} \left[ \frac{\sin z}{3D + 2} \right]$$

$$= -e^{-z} \left[ \frac{\sin z}{3D + 2} \times \frac{3D - 2}{3D - 2} \right]$$

$$= -e^{-z} \left[ \frac{3\cos z - 2\sin z}{9D^2 - 4^2} \right] \quad (D^2 \rightarrow -1^2)$$

$$= -e^{-z} \left[ \frac{3\cos z - 2\sin z}{-13} \right]$$

$$= \frac{e^{-z}}{13} (3\cos z - 2\sin z)$$

$$\text{P.I.} = \frac{5}{2} e^z + \frac{1}{13} e^{-z} (3\cos z - 2\sin z)$$

Complete solution of Eqn. (2) is

$$y = \text{C.F.} + \text{P.I.}$$

$$y = C_1 e^{-z} + C_2 e^{\left(\frac{1}{2}\right)z} + \frac{5}{2} e^z + \frac{1}{13} e^{-z} (3\cos z - 2\sin z)$$

∴ The general solution of Eqn. (1) is

$$y = \frac{C_1}{x} + C_2 \sqrt{x} + \frac{5}{2} x + \frac{1}{13x} [3\cos(\log x) - 2\sin(\log x)].$$

8. Solve  $x^3 \frac{d^3 y}{dx^3} + 2x^2 \frac{d^2 y}{dx^2} + 2y = 10 \left( x + \frac{1}{x} \right)$ .

**Solution.** The given equation

$$x^3 \frac{d^3 y}{dx^3} + 2x^2 \frac{d^2 y}{dx^2} + 2y = 10 \left( x + \frac{1}{x} \right) \quad \dots(1)$$

Substitute  $x = e^z$  or  $z = \log x$

Hence,  $x \frac{dy}{dx} = Dy$ ,  $x^2 \frac{d^2 y}{dx^2} = D(D-1)y$

$$x^3 \frac{d^3 y}{dx^3} = D(D-1)(D-2)y$$

Eqn. (1) reduces to linear differential equation as

$$[D(D-1)(D-2) + 2D(D-1) + 2]y = 10 \left( e^z + \frac{1}{e^z} \right)$$

$$\text{i.e.,} \quad (D^3 - D^2 + 2)y = 10(e^z + e^{-z})$$

which is linear differential equation with constant coefficients

A.E. is  $m^3 - m^2 + 2 = 0$

i.e.,  $(m+1)(m^2 - 2m + 2) = 0$

Hence  $m = -1, 1 \pm i$

Therefore, C.F. =  $C_1 e^{-z} + e^z (C_2 \cos z + C_3 \sin z)$

$$\text{P.I.} = \frac{1}{D^3 - D^2 + 2} 10(e^z + e^{-z})$$

$$\begin{aligned}
&= 10 \left\{ \frac{1}{D^3 - D^2 + 2} e^z + \frac{1}{D^3 - D^2 + 2} \cdot e^{-z} \right\} \\
&= 10 [\text{P.I.}_1 + \text{P.I.}_2] \\
\text{P.I.}_1 &= \frac{1}{D^3 - D^2 + 2} e^z \quad D \rightarrow 1 \\
&= \frac{e^z}{2} \\
\text{P.I.}_2 &= \frac{1}{D^3 - D^2 + 2} e^{-z} \quad D \rightarrow -1 \\
&= \frac{1}{(-1)^3 - (-1)^2 + 2} e^{-z} \quad Dr = 0 \\
&= \frac{1}{3D^2 - 2D} z e^{-z} \quad D \rightarrow -1 \\
&= \frac{z e^{-z}}{3(-1)^2 - 2(-1)} \\
\text{P.I.}_2 &= \frac{z e^{-z}}{5} \\
\text{P.I.} &= 10 \left\{ \frac{e^z}{2} + \frac{z e^{-z}}{5} \right\}
\end{aligned}$$

Hence the complete solution is

$$\begin{aligned}
y &= \text{C.F.} + \text{P.I.} \\
&= C_1 e^{-z} + e^z (C_2 \cos z + C_3 \sin z) + 10 \left[ \frac{e^z}{2} + \frac{z e^{-z}}{5} \right]
\end{aligned}$$

Substituting  $e^z = x$  or  $z = \log x$

$$\text{We get } y = \frac{C_1}{x} + x \{ C_2 \cos(\log x) + C_3 \sin(\log x) \} + 5x + \frac{2 \log x}{x} .$$

9. Solve  $x^4 \frac{d^3 y}{dx^3} + 2x^3 \frac{d^2 y}{dx^2} - x^2 \frac{dy}{dx} + xy = \sin(\log x)$ .

**Solution.** Dividing throughout the equation by 'x', we get

$$x^3 \frac{d^3 y}{dx^3} + 2x^2 \frac{d^2 y}{dx^2} - x \frac{dy}{dx} + y = \frac{\sin(\log x)}{x} \quad \dots(1)$$

Now substitute  $x = e^z$  and  $z = \log x$

$$x \frac{dy}{dx} = Dy, \quad x^2 \frac{d^2 y}{dx^2} = D(D-1)y,$$



$$x^3 \frac{d^3 y}{dx^3} = D(D-1)(D-2)y$$

Eqn. (1) reduces to

$$[D(D-1)(D-2) + 2D(D-1) - D + 1]y = \frac{\sin z}{e^z}$$

$$\text{i.e., } (D^3 - D^2 - D + 1)y = e^{-z} \sin z$$

$$\text{A.E. is } m^3 - m^2 - m + 1 = 0$$

$$\Rightarrow m^2(m-1) - 1(m-1) = 0$$

$$\Rightarrow (m^2 - 1)(m-1) = 0$$

$$\Rightarrow m^2 - 1 = 0, \quad m - 1 = 0$$

$$\Rightarrow m = \pm 1, 1 \Rightarrow m = -1, +1, +1$$

$$\text{C.F.} = (C_1 + C_2 z) e^z + C_3 e^{-z} \text{ and}$$

$$\text{P.I.} = \frac{1}{(D-1)^2(D+1)} e^{-z} \sin z$$

Taking  $e^{-z}$  outside and replacing

$$(D \rightarrow D-1)$$

$$= e^{-z} \frac{1}{(D-2)^2 D} \sin z$$

$$= e^{-z} \frac{1}{(D^2 + 4 - 4D) D} \sin z$$

$$= e^{-z} \frac{\sin z}{D^3 + 4D - 4D^2} \quad (D^2 \rightarrow -1^2)$$

$$= e^{-z} \frac{\sin z}{-D + 4D + 4}$$

$$= e^{-z} \frac{\sin z}{4D + 3} \times \frac{4D - 3}{4D - 3}$$

$$= e^{-z} \left[ \frac{4 \cos z - 3 \sin z}{16D^2 - 9} \right] \quad (D^2 \rightarrow -1^2)$$

$$= e^{-z} \frac{4 \cos z - 3 \sin z}{-25}$$

$$= \frac{-1}{25} e^{-z} (4 \cos z - 3 \sin z)$$

$\therefore$  The complete solution is

$$y = \text{C.F.} + \text{P.I.}$$

$$= (C_1 + C_2 z) e^z + C_3 e^{-z} + \frac{1}{25} [e^{-z} (4 \sin z - 3 \cos z)]$$

$$z = \log x \quad x = e^z$$

$$= (C_1 + C_2 \log x) \cdot x + \frac{C_3}{x} + \frac{1}{25x} [4 \sin(\log x) - 3 \cos(\log x)].$$

10. Solve  $(3x+2)^2 \cdot \frac{d^2y}{dx^2} + 3(3x+2) \frac{dy}{dx} - 36y = 3x^2 + 4x + 1$ .

**Solution.** The given equation is

$$(3x+2)^2 \cdot \frac{d^2y}{dx^2} + 3(3x+2) \frac{dy}{dx} - 36y = 3x^2 + 4x + 1 \quad \dots(1)$$

Substitute  $3x+2 = e^z$  or  $z = \log(3x+2)$

So that  $(3x+2) \frac{dy}{dx} = 3Dy$

$$(3x+2)^2 \frac{d^2y}{dx^2} = 3^2 D(D-1)y$$

Also,  $x = \frac{e^z - 2}{3}$

Substituting these values in Eqn. (1), we get

$$3^2 D(D-1)y + 3 \cdot 3 Dy - 36y = 3 \left( \frac{e^z - 2}{3} \right)^2 + 4 \left( \frac{e^z - 2}{3} \right) + 1$$

$$9(D^2 - 4)y = \frac{e^{2z} - 1}{3}$$

i.e.,  $(D^2 - 4)y = \frac{1}{27}(e^{2z} - 1) \quad \dots(2)$

Which is a linear differential equation with constant coefficients

Now the A.E.  $m^2 - 4 = 0$

Whose roots are  $m^2 = 4$

$$m = \pm 2$$

$$\text{C.F.} = C_1 e^{2z} + C_2 e^{-2z} \text{ and}$$

$$\text{P.I.} = \frac{1}{D^2 - 4} \frac{1}{27} (e^{2z} - 1)$$

$$= \frac{1}{27} \left[ \frac{e^{2z}}{(D-2)(D+2)} - \frac{1}{D^2 - 4} e^{0z} \right]$$

$$= \frac{1}{27} [\text{P.I.}_1 - \text{P.I.}_2]$$

$$\text{P.I.}_1 = \frac{e^{2z}}{(D-2)(D+2)} \quad (D \rightarrow 2)$$

$$(D \rightarrow 0)$$

$$\begin{aligned}
 &= \frac{ze^{2z}}{2D} && (D \rightarrow 2) \\
 &= \frac{ze^{2z}}{4} \\
 \text{P.I.}_2 &= \frac{ze^{oz}}{D^2 - 4} && (D \rightarrow 0) \\
 &= \frac{1}{-4} \\
 \text{P.I.} &= \frac{1}{27} \left[ \frac{1}{4} ze^{2z} + \frac{1}{4} \right] \\
 \text{P.I.} &= \frac{1}{108} (ze^{2z} + 1)
 \end{aligned}$$

General solution is

$$\begin{aligned}
 y &= \text{C.F.} + \text{P.I.} \\
 &= C_1 e^{2z} + C_2 e^{-2z} + \frac{1}{108} (ze^{2z} + 1) \\
 y &= C_1 (3x+2)^2 + C_2 (3x+2)^{-2} + \frac{1}{108} [(3x+2)^2 \log(3x+2) + 1].
 \end{aligned}$$

## EXERCISE 6.2

Solve the following equations:

$$1. \quad x^2 \frac{d^2 y}{dx^2} + y = 3x^2. \quad \left[ \text{Ans. } y = \sqrt{x} \left[ C_1 \cos \left( \frac{\sqrt{3}}{2} \log x \right) + C_2 \sin \left( \frac{\sqrt{3}}{2} \log x \right) \right] + x^2 \right]$$

$$2. \quad x^2 \frac{d^2 y}{dx^2} + 5x \frac{dy}{dx} + 4y = x^4. \quad \left[ \text{Ans. } y = x^{-2} (C_1 + C_2 \log x) + \frac{x^4}{36} \right]$$

$$3. \quad x^2 \frac{d^2 y}{dx^2} + 2x \frac{dy}{dx} - 20y = (x+1)^2. \quad \left[ \text{Ans. } y = C_1 x^{-5} + C_2 x^4 - \left[ \frac{x^2}{14} + \frac{x}{9} + \frac{1}{20} \right] \right]$$

$$4. \quad x^2 \frac{d^2 y}{dx^2} - x \frac{dy}{dx} + 2y = x \sin(\log x). \\
 \left[ \text{Ans. } y = x \left[ C_1 \cos(\log x) + C_2 \sin(\log x) \right] - \frac{x}{2} \log x \cos(\log x) \right]$$

$$5. \quad x^2 \frac{d^2 y}{dx^2} + 3x \frac{dy}{dx} + y = x + \frac{1}{x}. \quad \left[ \text{Ans. } y = x^{-1} [C_1 + C_2 \log x] + \frac{x}{4} + \frac{x^{-1}(\log x)^2}{2} \right]$$

$$6. \quad x^2 \frac{d^2y}{dx^2} + 4x \frac{dy}{dx} + 2y = e^x. \quad \left[ \text{Ans. } y = C_1 x^{-1} + C_2 x^{-2} e^x \right]$$

$$7. \quad x^2 \frac{d^2y}{dx^2} - x \frac{dy}{dx} + 4y = \cos(\log x) + x \sin(\log x). \\ \left[ \text{Ans. } y = x \left[ C_1 \cos(\sqrt{3} \log x) + C_2 \sin(\sqrt{3} \log x) \right] + \frac{1}{13} \left[ 3 \cos(\log x) - 2 \sin(\log x) \right] + \frac{x}{2} \sin(\log x) \right]$$

$$8. \quad x^2 \frac{d^2y}{dx^2} - 3x \frac{dy}{dx} + 5y = x^2 \sin(\log x). \\ \left[ \text{Ans. } y = x^2 \left[ C_1 \cos(\log x) + C_2 \sin(\log x) \right] - \frac{x^2}{2} \log x \cos(\log x) \right]$$

$$9. \quad x^2 y'' - xy' + y = \log x. \quad \left[ \text{Ans. } y = (C_1 + C_2 \log x)x + \log x + 2 \right]$$

$$10. \quad x^4 \frac{d^3y}{dx^3} + 2x^3 \frac{d^2y}{dx^2} - x^2 \frac{dy}{dx} + xy = 1. \quad \left[ \text{Ans. } y = x(C_1 + C_2 \log x) + C_3 x^{-1} + \frac{1}{4} x^{-1} \log x \right]$$

$$11. \quad x^2 \frac{d^2y}{dx^2} + 5x \frac{dy}{dx} + 4y = x \log x. \quad \left[ \text{Ans. } y = x^{-2} (C_1 + C_2 \log x) + \frac{x}{9} \left( \log x - \frac{2}{3} \right) \right]$$

$$12. \quad x^3 \frac{d^3y}{dx^3} + 3x^2 \frac{d^2y}{dx^2} + x \frac{dy}{dx} + 8y = 65 \cos(\log x). \\ \left[ \text{Ans. } y = C_1 x^{-2} + x \left[ C_2 \cos(3 \log x) + C_3 \sin(\sqrt{3} \log x) \right] + 8 \cos(\log x) - \sin(\log x) \right]$$

$$13. \quad x^2 \frac{d^2y}{dx^2} - 3x \frac{dy}{dx} + 5y = x^2 \sin(\log x). \\ \left[ \text{Ans. } y = x^2 \left[ C_1 \cos(\log x) + C_2 \sin(\log x) \right] - \frac{x^2}{2} \log x \cos(\log x) \right]$$

$$14. \quad (1+x)^2 \frac{d^2y}{dx^2} + (1+x) \frac{dy}{dx} + y = 4 \cos \log(1+x). \\ \left[ \text{Ans. } y = C_1 \cos[\log(1+x)] + C_2 \sin[\log(1+x)] + 2 \log(1+x) \sin[\log(1+x)] \right]$$

$$15. \quad (2x+1)^2 \cdot \frac{d^2y}{dx^2} - 2(2x+1) \frac{dy}{dx} - 12y = 16x. \\ \left[ \text{Ans. } y = C_1 (2x+1)^3 + C_2 (2x-1)^{-1} - \frac{3}{16} (2x+1) + \frac{1}{4} \right]$$

$$16. \quad (2x-1)^3 \frac{d^3y}{dx^3} + (2x-1) \frac{dy}{dx} + 2y = 0. \\ \left[ \text{Ans. } y = (2x-1) \left[ C_1 + C_2 (2x-1)^{\frac{\sqrt{3}}{2}} + C_3 (2x-1)^{\frac{-\sqrt{3}}{2}} \right] \right]$$

### 6.3 SOLUTION OF INITIAL AND BOUNDARY VALUE PROBLEMS

The differential equation in which the conditions are specified at a single value of the independent variable say  $x = x_0$  is called an Initial Value Problem (IVP).

If  $y = y(x)$ , the initial conditions usually will be of the form.

$$y(x_0) = y_0, \quad y'(x_0) = y_1, \quad \dots \quad y^{(n-1)}(x_0) = y_{n-1}$$

The differential equation in which the conditions are specified for a given set of  $n$  values of the independent variables is called a Boundary Value Problem (BVP).

If  $y = y(x)$  the  $n$  boundary conditions will be

$$y(x_1) = y_1, \quad y(x_2) = y_2, \quad y(x_3) = y_3 \dots \\ y(x_n) = y_n.$$

We can also have problems involving a system of *d.e.* (simultaneous *de.s*) with these type of conditions.

#### WORKED OUT EXAMPLES

1. Solve the initial value problem  $\frac{d^2x}{dt^2} + 5\frac{dx}{dt} + 6x = 0$ , given that

$$x(0) = 0, \quad \frac{dx}{dt}(0) = 15.$$

**Solution.** We have  $(D^2 + 5D + 6)y = 0$

A.E.,  $m^2 + 5m + 6 = 0$

$$(m + 2)(m + 3) = 0$$

$$\Rightarrow m = -2, -3$$

Therefore general solution is

$$x = x(t) = C_1e^{-2t} + C_2e^{-3t} \quad \dots(1)$$

This is the general solution of the given equation

Now, consider,  $x(0) = 0$

Eqn. (1), becomes  $x(0) = C_1(1) + C_2(1)$

*i.e.*,  $C_1 + C_2 = 0 \quad \dots(2)$

Also we have from Eqn. (1),

$$\frac{dx}{dt} = -2C_1e^{-2t} - 3C_2e^{-3t}$$

Applying the conditions,  $\frac{dx}{dt}(0) = 15$

We obtain

$$-2C_1 - 3C_2 = 15 \quad \dots(3)$$

Solving equations (2) and (3), we get  $C_1 = 15$ ,  $C_2 = -15$

thus  $x(t) = 15(e^{-2t} - e^{-3t})$ .

2. Solve  $\frac{d^2y}{dx^2} + 4\frac{dy}{dx} + 3y = e^{-x}$  subject to the conditions  $y(0) = y'(0)$ .

**Solution.** We have  $(D^2 + 4D + 3)y = e^{-x}$

A.E.  $m^2 + 4m + 3 = 0$

or  $(m + 1)(m + 3) = 0$

$$m = -1, -3$$

$$\text{C.F.} = C_1 e^{-x} + C_2 e^{-3x}$$

$$\text{P.I.} = \frac{e^{-x}}{D^2 + 4D + 3} \quad D \rightarrow -1$$

$$= \frac{e^{-x}}{(-1)^2 + 4(-1) + 3} \quad Dr = 0$$

$$= \frac{x e^{-x}}{2D + 4} \quad D \rightarrow -1$$

$$= \frac{x e^{-x}}{2}$$

$$y = \text{C.F.} + \text{P.I.}$$

$$y = C_1 e^{-x} + C_2 e^{-3x} + \frac{x e^{-x}}{2} \quad \dots(1)$$

$$y' = \frac{dy}{dx} = -C_1 e^{-x} - 3C_2 e^{-3x} + \frac{1}{2}(-x e^{-x} + e^{-x}) \quad \dots(2)$$

Consider the conditions  $y(0) = 1$  and  $y'(0) = 1$

Eqn. (1) and (2) become,

$$1 = C_1 + C_2 \text{ and } 1 = -C_1 - 3C_2 + \frac{1}{2}.$$

By solving these equations we get,

$$C_1 = \frac{7}{4} \text{ and } C_2 = \frac{-3}{4}$$

Thus  $y = \frac{7}{4}e^{-x} - \frac{3}{4}e^{-3x} + \frac{x e^{-x}}{2}$  is the particular solution.

3. A particle moves along the  $x$ -axis according to the law  $\frac{d^2x}{dt^2} + 6\frac{dx}{dt} + 25x = 0$ . If the particle is started at  $x = 0$  with an initial velocity of 12 ft/sec to the left, determine  $x$  in terms of  $t$ .

**Solution.** We have  $(D^2 + 6D + 25)x = 0$

From the given data, the initial conditions  $x = 0$  when  $t = 0$  and  $\frac{dx}{dt} = -12$  when  $t = 0$

$$\text{A.E.} \quad m^2 + 6m + 25 = 0$$

$$m = -3 \pm 4i$$

$$\therefore x = x(t) = e^{-3t} (C_1 \cos 4t + C_2 \sin 4t) \quad \dots(1)$$

$$\begin{aligned} \text{Now} \quad x'(t) &= + 3e^{-3t} (-C_1 \sin 4t \cdot 4 + 4 C_2 \cos 4t) \\ &= - 12 e^{-3t} (C_1 \cos 4t - C_2 \sin 4t) \quad \dots(2) \end{aligned}$$

$$\text{Consider} \quad x(0) = 0 \text{ and } x'(0) = -12$$

Eqns. (1) and (2) become,

$$0 = C_1 \text{ and } -12 = 4C_2 - 3C_1$$

$$\therefore C = 0 \text{ and } C_2 = -3$$

$$x(t) = -3e^{-3t} \sin 4t.$$

### EXERCISE 6.3

Solve the following initial value problems:

$$1. \quad \frac{d^2 y}{dx^2} + 6 \frac{dy}{dx} + 9y = 12e^{-3x^2} = y(0) = 0, = y'(0) \quad \left[ \text{Ans. } y = e^{-3x} \cdot x^4 \right]$$

$$2. \quad \frac{d^4 y}{dx^4} - y = 0; y(0) = 1 \text{ and } y'(0) = 0 = y''(0) = y'''(0). \quad \left[ \text{Ans. } y = \frac{1}{2} (\cosh x + \cos x) \right]$$

$$3. \quad y'''(t) + y'(t) = e^{2t}, y(0) = 0 = y'(0) = y'''(0). \quad \left[ \text{Ans. } y = \frac{1}{10} (-5 + e^{2t} + 4 \cos t - 2 \sin t) \right]$$

### ADDITIONAL PROBLEMS (From Previous Years VTU Exams.)

$$1. \quad \text{Using the method of variation of parameters solve: } \frac{d^2 y}{dx^2} + y = \frac{1}{1 + \sin x}$$

$$\text{Solution. We have } (D^2 + 1)y = \frac{1}{1 + \sin x}$$

$$\text{A.E. is } m^2 + 1 = 0 \text{ and hence } m = \pm i$$

$$\therefore \text{C.F.} = C_1 \cos x + C_2 \sin x$$

$$y = A(x) \cos x + B(x) \sin x \quad \dots(1)$$

be the complete solution of the given *d.e.* where  $A(x)$  and  $B(x)$  are to be found.

$$\text{We have} \quad y_1 = \cos x \quad y_2 = \sin x$$

$$y_1' = -\sin x \quad y_2' = \cos x$$

$$W = y_1 y_2' - y_2 y_1' = 1 \quad \text{Also} \quad \phi(x) = \frac{1}{1 + \sin x}$$

Now,  $A' = \frac{-y_2 \phi(x)}{W}$  and  $B' = \frac{y_1 \phi(x)}{W}$

*i.e.*,  $A' = \frac{-\sin x}{1 + \sin x}$  and  $B' = \frac{\cos x}{1 + \sin x}$

consider  $A' = \frac{-(1 + \sin x - 1)}{1 + \sin x} = -1 + \frac{1}{\sin x}$

$$A = \int \left[ -1 + \frac{1}{1 + \sin x} \right] dx + k_1$$

$$= -x + \int \frac{1 - \sin x}{\cos^2 x} dx + k_1$$

$$= -x + \int (\sec^2 x - \sec x \tan x) dx + k_1$$

$$A = -x + \tan x - \sec x + k_1 \quad \dots(2)$$

Also,  $B' = \frac{\cos x}{1 + \sin x} = \frac{\cos x (1 + \sin x)}{\cos^2 x} = \frac{1 - \sin x}{\cos x}$

$$B = \int \frac{1 - \sin x}{\cos x} dx + k_2$$

$$= \int (\sec x - \tan x) dx + k_2$$

$$= \log (\sec x + \tan x) + \log (\cos x) + k_2$$

$$= \log \left( \frac{1 + \sin x}{\cos x} \right) + \log (\cos x) + k_2$$

$$= \log (1 + \sin x) - \log (\cos x) + \log (\cos x) + k_2$$

$$B = \log (1 + \sin x) + k_2 \quad \dots(3)$$

Using Equations (2) and (3) in (1), we have

$$y = [-x + \tan x - \sec x + k_1] \cos x + [\log (1 + \sin x) + k_2] \sin x$$

*i.e.*,  $y = k_1 \cos x + k_2 \sin x - x \cos x + \sin x - 1 + \sin x \log (1 + \sin x)$

The term  $\sin x$  can be neglected in view of them  $k_2 \sin x$  present in the solution

Thus,  $y = k_1 \cos x + k_2 \sin x - (x \cos x + 1) + \sin x \log (1 + \sin x).$

2. Solve by the method of variation of parameters  $\frac{d^2 y}{dx^2} + 4y = 4 \tan 2x.$

**Solution.** Refer page no. 282. Example 2.

3. Solve  $\frac{d^2 y}{dx^2} - 2 \frac{dy}{dx} + 2y = e^x \tan x$  using the method of variation of parameters

**Solution.** Refer page no. 287, Example 7.



4. Solve  $\frac{d^2 y}{dx^2} + a^2 y = \tan ax$ .

**Solution.** We have  $(D^2 + a^2) y = \tan ax$

A.E. is  $m^2 + a^2 = 0 \Rightarrow m = \pm ia$

C.F. :  $= C_1 \cos ax + C_2 \sin ax$

be the complete solution of the *d.e.* where  $A$  and  $B$  are functions of  $x$  to be found.

We have  $y_1 = \cos ax$   $y_2 = \sin ax$   
 $y_1' = -a \sin ax$   $y_2' = a \cos ax$

$W = y_1 y_2' - y_2 y_1' = a$  Also  $\phi(x) = \tan ax$

$A' = \frac{-y_2 \phi(x)}{W}$   $B' = \frac{y_1 \phi(x)}{W}$

$A' = \frac{-1 \sin^2 ax}{a \cos ax}$   $B' = \frac{\cos ax \tan ax}{a}$

$A' = \frac{-1 (1 - \cos^2 ax)}{a \cos ax}$   $B' = \frac{\sin ax}{a}$

$\Rightarrow A = \frac{1}{a} \int (\cos ax - \sec ax) dx + k_1, \quad B = \int \frac{\sin ax}{a} dx + k_2$

$\Rightarrow A = \frac{1}{a^2} [\sin ax - \log \sec ax + \tan ax] + k_1$

$B = -\frac{\cos ax}{a^2} + k_2$

Substituting these values in Eqn. (1), we get

$$y = \left\{ \frac{1}{a^2} [\sin ax - \log (\sec ax + \tan ax)] + k_1 \right\} \cos ax + \left\{ -\frac{\cos ax}{a^2} + k_2 \right\} \sin ax$$

Thus  $y = k_1 \cos ax + k_2 \sin ax - \frac{1}{a^2} \log (\sec ax + \tan ax) \cos ax$ .

5. Using the method of variation of parameters find the solution of  $\frac{d^2 y}{dx^2} - 2 \frac{dy}{dx} + y = \frac{e^x}{x}$ .

**Solution.** We have  $(D^2 + 2D + 1) y = \frac{e^x}{x}$

A.E. is  $m^2 - 2m + 1 = 0 \Rightarrow (m - 1)^2 = 0$

$m = 1, 1$  are the roots of A.E.

$\therefore$  C.F. =  $(C_1 + C_2 x) e^x$

$y = (A + Bx) e^x$  ...(1)

where  $A = A(x), B = B(x)$

be the complete solution of the *d.e.* and we shall find  $A, B$ , we have

$y_1 = e^x, \quad y_2 = x e^x$

$$\therefore \quad y_1' = e^x \qquad y_2' = (x+1)e^x$$

$$W = y_1 y_2' - y_2 y_1' = e^{2x} \quad \text{Also} \quad \phi(x) = \frac{e^x}{x}$$

Further, we have

$$A' = \frac{-y_2 \phi(x)}{W} \quad \text{and} \quad B' = \frac{y_1 \phi(x)}{W}$$

$$A' = \frac{-xe^x \cdot \frac{e^x}{x}}{e^{2x}} \qquad B' = \frac{e^x \cdot \frac{e^x}{x}}{e^{2x}}$$

$$\text{i.e.,} \quad A' = -1 \qquad B' = \frac{1}{x}$$

$$\Rightarrow \quad A = \int -1 \cdot dx + k_1 \qquad B = \int \frac{1}{x} dx + k_2$$

$$\text{i.e.,} \quad A = -x + k_1 \qquad B = \log x + k_2.$$

Using these values in Eqn. (1), we have

$$y = (-x + k_1)e^x + (\log x + k_2)xe^x$$

$$\text{i.e.,} \quad y = (k_1 + k_2x)e^x + (\log x - 1)xe^x$$

The term  $-xe^x$  can be neglected in view of the term  $k_2xe^x$  present in the solution.

$$\text{Thus} \quad y = (k_1 + k_2x)e^x + x \log x e^x.$$

6. Solve  $x^3 \frac{d^3y}{dx^3} + 3x^2 \frac{d^2y}{dx^2} + x \frac{dy}{dx} + 8y = 65 \cos(\log x)$ .

**Solution.** Put  $t = \log x$  or  $x = e^t$

$$\text{Thus, we have} \quad xy' = Dy, \quad n^2y'' = D(D-1)y$$

$$x^3y''' = D(D-1)(D-2)y \qquad \text{where } D = \frac{d}{dt}$$

Hence, the given d.e. becomes

$$[D(D-1)(D-2) + 3D(D-1) + D + 8]y = 65 \cos t$$

$$\text{i.e.,} \quad = (D^3 - 3D^2 + 2D + 3D^2 - 3D + D + 8)y = 65 \cos t$$

$$\text{or} \quad (D^3 + 8)y = 65 \cos t$$

$$\text{A.E. :} \quad m^3 + 8 = 0 \quad \Rightarrow \quad m^3 - 2^3 = 0$$

$$(m+2)(m^2 - 2m + 4) = 0$$

$$m = -2 \quad \text{and} \quad m^2 - 2m + 4 = 0$$

By solving  $m^2 - 2m + 4 = 0$ , we have

$$m = \frac{2 \pm \sqrt{4-16}}{2} = \frac{2 \pm 2i\sqrt{3}}{2} = 1 \pm i\sqrt{3}$$

$$\text{C.F.} = C_1e^{-2t} + e^t \{C_2 \cos \sqrt{3}t + C_3 \sin \sqrt{3}t\}$$

Also  $P.I. = \frac{65 \cos t}{D^3 + 8} \quad D^2 \rightarrow -1^2 = -1$

$$P.I. = \frac{65 \cos t}{-D + 8} = \frac{65(8 + D) \cos t}{64 - D^2}, \quad D^2 \rightarrow -1$$

$$= \frac{65(8 \cos t - \sin t)}{65}$$

$$P.I. = 8 \cos t - \sin t$$

Complete solution :  $y = C.F. + P.I.$  with  $t = \log x,$   
 $e^t = x$

$$= \frac{C_1}{x} + x \left\{ C_2 \cos(\sqrt{3} \log x) + C_3 \sin(\sqrt{3} \log x) \right\}$$

$$+ 8 \cos(\log x) - \sin(\log x).$$

7. Solve  $x^2 \frac{d^3 y}{dx^3} + 3x \frac{d^2 y}{dx^2} + \frac{dy}{dx} = x^2 \log x.$

**Solution.** Multiplying the equation by  $x$ , we have

$$x^3 \frac{d^3 y}{dx^3} + 3x^2 \frac{d^2 y}{dx^2} + x \frac{dy}{dx} = x^3 \log x \quad \dots(1)$$

put  $t = \log x$  or  $x = e^t$

then  $xy' = Dy,$   $x^2 y'' = D(D-1)y$

$$x^3 y''' = D(D-1)(D-2)y$$

Hence Eqn. (1) becomes

$$[D(D-1)(D-2) + 3D(D-1) + D] e^{3t} \cdot t$$

i.e.,  $D^3 y = 0$

A.E. :  $m^3 = 0$  and hence  $m = 0, 0, 0$

$\therefore$  C.F. =  $(C_1 + C_2 t + C_3 t^2) e^{0t}$

$$C.F. = C_1 + C_2 t + C_3 t^2$$

$$P.I. = \frac{e^{3t} t}{D^3} = e^{3t} \frac{t}{(D-3)^2}, \quad D \rightarrow D+3$$

$$= e^{3t} \frac{t}{D^3 + 9D^2 + 27D + 27}$$

P.I.<sub>3</sub> is found by division

$$27 + 27D + 9D^2 + D^3 \overline{\begin{array}{r} \frac{t}{27} - \frac{1}{27} \\ \hline t \\ t + 1 \\ \hline -1 \\ -1 \\ \hline 0 \end{array}}$$

$$\text{P.I.} = e^{3t} \cdot \frac{(t-1)}{27}$$

The complete solution :  $y = \text{C.F.} + \text{P.I.}$

with  $t = \log x$  and  $x = e^t$

$$\text{Thus } y = \left\{ C_1 + C_2 \log x + C_3 (\log x)^2 \right\} + \frac{x^3}{27} (\log x - 1).$$

8. Solve  $(2x+3)^2 \frac{d^2y}{dx^2} - (2x+3) \frac{dy}{dx} - 12y = 6x.$

**Solution.** Put  $t = \log(2x+3)$  or  $e^t = 2x+3$

Hence  $x = \frac{1}{2}(e^t - 3)$

Also, we have  $(2x+3)y' = 2Dy$

and  $(2x+3)^2 y'' = 2^2 D(D-1)y$

Hence, the given *d.e.* becomes

$$[4D(D-1) - 2D - 12]y = 6 \cdot \frac{1}{2}(e^t - 3)$$

*i.e.*,  $2(2D^2 - 2D - D - 6)y = 3(e^t - 3)$

*i.e.*,  $(2D^2 - 3D - 6)y = \frac{3}{2}(e^t - 3)$

A.E. is  $2m^2 - 3m - 6 = 0$

$$m = \frac{3 \pm \sqrt{9+48}}{4} = \frac{3 \pm \sqrt{57}}{4}$$

$\therefore$  C.F. =  $C_1 e^{\frac{(3+\sqrt{57})}{4}t} + C_2 e^{\frac{(3+\sqrt{57})}{4}t}$

$\therefore$  C.F. =  $e^{\frac{3t}{4}} \left[ C_1 e^{\frac{\sqrt{57}}{4}t} + C_2 e^{-\frac{\sqrt{57}}{4}t} \right]$

Also P.I. =  $\frac{3e^t}{2(2D^2 - 3D - 6)} - \frac{9e^{0t}}{2(2D^2 - 3D - 6)}$

$$= \frac{3e^t}{2(2-3-6)} - \frac{9e^{0t}}{2(0-0-6)}$$

$$\text{P.I.} = -\frac{3e^t}{14} + \frac{3}{4}$$

Complete solution  $y = \text{C.F.} + \text{P.I.}$

with  $t = \log(2x+3)$ ,  $e^t = 2x+3$

Thus, 
$$y = e^{\frac{3t}{4}} \left\{ C_1 e^{\frac{\sqrt{57}t}{4}} + C_2 e^{-\frac{\sqrt{57}t}{4}} \right\} - \frac{3}{14} e^t + \frac{3}{4}$$

where  $t = \log(2x + 3)$  and  $e^t = 2x + 3$ .

9. Solve the initial value problem:  $\frac{d^2y}{dx^2} + 4\frac{dy}{dx} + 5y + 2\cos hx = 0$ , given  $y = 0$ ,  $\frac{dy}{dx} = 1$  at  $x = 0$ .

**Solution.** We have  $(D^2 + 4D + 5)y = -2\cos hx$

i.e.,  $(D^2 + 4D + 5)y = -(e^x + e^{-x})$

A.E. is  $m^2 + 4m + 5 = 0$

$$m = \frac{-4 \pm \sqrt{16 - 20}}{2} = -2 \pm i$$

$\therefore$  C.F. =  $e^{-2x} (C_1 \cos x + C_2 \sin x)$

$$\begin{aligned} \text{P.I.} &= \frac{-e^x}{D^2 + 4D + 5} - \frac{e^{-x}}{D^2 + 4D + 5} \\ &= \frac{-e^x}{1 + 4 + 5} - \frac{e^{-x}}{1 + 4 + 5} \\ &= \frac{-e^x}{10} - \frac{e^{-x}}{2} \end{aligned}$$

$$\text{P.I.} = -\left[ \frac{e^x}{10} + \frac{e^{-x}}{2} \right]$$

Complete solution:  $y = \text{C.F.} + \text{P.I.}$

$$y = e^{-2x} (C_1 \cos x + C_2 \sin x) - \left( \frac{e^x}{10} + \frac{e^{-x}}{2} \right) \quad \dots(i)$$

Now, we apply the given initial conditions,  $y = 0$ ,  $\frac{dy}{dx} = 1$  at  $x = 0$

From Eqn. (i), we get

$$\frac{dy}{dx} = e^{-2x} (-C_1 \sin x + C_2 \cos x) - 2e^{-2x} (C_1 \cos x + C_2 \sin x) - \frac{e^x}{10} + \frac{e^{-x}}{2} \quad \dots(ii)$$

Using  $y = 0$  at  $x = 0$ , Eqn. (i) becomes

$$0 = C_1 - \left( \frac{1}{10} + \frac{1}{2} \right) \quad \text{or} \quad C_1 = \frac{3}{5}$$

Using  $\frac{dy}{dx} = 1$  at  $x = 0$ , Eqn. (ii) becomes

$$1 = C_2 - 2C_1 - \frac{1}{10} + \frac{1}{2} \quad \text{or} \quad C_2 - 2C_1 = \frac{3}{5}$$

Using  $C_1 = \frac{3}{5}$ , we get  $C_2 = \frac{9}{5}$

Thus, the required particular solution from Eqn. (i) is given by

$$y = \frac{3}{5} e^{-2x} (\cos x + 3 \sin x) - \left( \frac{e^x}{10} + \frac{e^{-x}}{2} \right).$$

10. Solve  $\frac{d^2 y}{dx^2} - 4 \frac{dy}{dx} + 5y = 0$ . Subject to the conditions  $\frac{dy}{dx} = 2$ ,  $y = 1$  at  $x = 0$ .

**Solution.** We have  $(D^2 - 4D + 5)y = 0$

A.E. :  $m^2 - 4m + 5 = 0$

$$m = \frac{4 \pm \sqrt{16 - 20}}{2} = \frac{4 \pm 2i}{2} = 2 \pm i$$

$\therefore$  C.F. =  $e^{2x} (C_1 \cos x + C_2 \sin x)$

$\therefore$   $y = e^{2x} (C_1 \cos x + C_2 \sin x)$  ... (1)

Also  $\frac{dy}{dx} = e^{2x} (-C_1 \sin x + C_2 \cos x) + 2e^{2x} (C_1 \cos x + C_2 \sin x)$  ... (2)

Consider  $y = 1$  at  $x = 0$ , Eqn. (1) becomes

$$1 = 1 (C_1 + 0) \quad \therefore C_1 = 0$$

Also by the condition  $\frac{dy}{dx} = 2$  at  $x = 0$ , Eqn. (2) becomes

$$2 = C_2 + 2C_1$$

Using  $C_1 = 0$ , we get  $C_2 = 2$

Thus  $y = e^{2x} (\cos x)$  is the particular solution.

11. Solve the initial value problem  $\frac{d^2 y}{dx^2} + y = \sin(x + a)$  satisfying the condition  $y(0) = 0$ ,  $y'(0) = 0$ .

**Solution.** We have  $(D^2 + 1)y = \sin(x + a)$

A.E. :  $m^2 + 1 = 0$  and hence  $m = \pm i$

$\therefore$  C.F. =  $C_1 \cos x + C_2 \sin x$

$$\text{P.I.} = \frac{\sin(x+a)}{D^2 + 1} \quad D^2 \rightarrow -1^2 = -1$$

The denominator becomes zero

$$\begin{aligned} \text{P.I.} &= x \frac{\sin(x+a)}{2D} \times \frac{D}{D} \\ &= \frac{x \cos(x+a)}{2} \quad D^2 \rightarrow -1^2 = -1 \end{aligned}$$

$$\text{P.I.} = \frac{-x \cos(x+a)}{2}$$

∴ The complete solution is  $y = \text{C.F.} + \text{P.I.}$

$$y = C_1 \cos x + C_2 \sin x - \frac{x \cos(x+a)}{2} \quad \dots(1)$$

Now, 
$$y' = -C_1 \sin x + C_2 \cos x - \frac{x \sin(x+a)}{2} - \frac{\cos(x+a)}{2} \quad \dots(2)$$

Using  $y(0) = 0$ ,  $y'(0) = 0$  in Eqns. (1) and (2) respectively, we have

$$C_1 = 0 \quad \text{and} \quad C_2 = \frac{\cos a}{2}$$

Thus by using these values in Eqn. (1), we get the particular solution,

$$\begin{aligned} y &= \frac{\cos a}{2} \sin x - \frac{x \cos(x+a)}{2} \\ &= \frac{1}{2} [\cos a \sin x - x \cos(x+a)] \end{aligned}$$

**12.** Solve the initial value problem

$$\frac{d^2x}{dt^2} + 4 \frac{dx}{dt} + 29x = 0, \text{ given } x(0) = 0, \frac{dx}{dt}(0) = 15.$$

**Solution.** We have  $(D^2 + 4D + 29)y = 0$

A.E. :  $m^2 + 4m + 29 = 0$

$$m = \frac{-4 \pm \sqrt{16 - 116}}{2} = \frac{-4 \pm 10i}{2} = -2 \pm 5i$$

∴ 
$$x(t) = e^{-2t} (C_1 \cos 5t + C_2 \sin 5t) \quad \dots(1)$$

Now, 
$$\frac{dx}{dt} = x'(t) = e^{-2t} (-5C_1 \sin 5t + 5C_2 \cos 5t) - 2e^{-2t} (C_1 \cos 5t + C_2 \sin 5t) \quad \dots(2)$$

Let us consider  $x(0) = 0$  and  $x'(0) = 15$

Equations (1) and (2) respectively becomes

$$0 = C_1 \quad \text{and} \quad 15 = 5C_2 - 2C_1$$

∴ 
$$C_1 = 0 \quad \text{and} \quad C_2 = 3$$

Thus,  $x(t) = 3e^{-2t} \sin 5t$  is the required particular solution.

## OBJECTIVE QUESTIONS

**1.** Match the following and find the correct alternative

I. Cauchy's equation (i)  $(x+2)^2 \frac{d^2y}{dx^2} + (x+2) \frac{dy}{dx} + y = 5$

II. Bernoulli's equation (ii)  $x^2 \cdot \frac{d^3y}{dx^3} - x \frac{d^2y}{dx^2} = e^x$

- III. Method of variation of parameters
- (iii)  $\frac{dy}{dx} + xy = x^2$
- (iv)  $\frac{dy}{dx} + xy = x^2 y^2$
- (v)  $y dx^2 - x dy^2 = 0$
- (vi)  $(D^2 + a) y = \tan x$
- (vii)  $\frac{dy}{dx} = \frac{y-x}{y+x}$

(a) I (i), II (iii), III (vii)

(b) I (ii), II (iii), III (v)

(c) I (i), II (iv), III (vi)

(d) I (ii), II (iv), III (vi)

[Ans. d]

2. The homogeneous linear differential equation whose auxiliary equation has roots 1, 1 and -2 is

(a)  $(D^3 + D^2 + 2D + 2) y = 0$

(b)  $(D^3 + 3D - 2) y = 0$

(c)  $(D^3 + 3D + 2) y = 0$

(d)  $(D + 1)^2 (D - 2) y = 0.$

[Ans. c]

3. The general solution of  $(x^2 D^2 - xD) y = 0$  is

(a)  $y = C_1 + C_2 e^x$

(b)  $y = C_1 + C_2 x$

(c)  $y = C_1 + C_2 x^2$

(d)  $y = C_1 x + C_2 x^2.$

[Ans. c]

4. Every solution of  $y'' + ay' + by = 0$ , where  $a$  and  $b$  are constants approaches to zero as  $x \rightarrow \alpha$  provided.

(a)  $a > 0, b > 0$

(b)  $a > 0, b < 0$

(c)  $c < 0, b < 0$

(d)  $a < 0, b > 0.$

[Ans. a]

5. By the method of variation of parameters  $y'' + a^2 y = \sec ax$ , the value of  $A$  is

(a)  $\frac{-\log(\sec ax)}{a^2} + k_1$

(b)  $\frac{-\log \sec ax}{a} + k_1$

(c)  $\frac{\log \sec ax}{a^3} + k_1$

(d) None.

[Ans. a]

6. By the method of variation of parameters, the value of  $W$  is called

(a) The Demorgan's function

(b) Euler's function

(c) Wronskian of the function

(d) Robert's function.

[Ans. c]

7. The method of variation of parameters, the formular for  $A'$  is

(a)  $\frac{y_1 \phi(x)}{W}$

(b)  $\frac{y_2 \phi(x)}{W}$

(c)  $\frac{-y_2 \phi(x)}{W}$

(d) None.

[Ans. c]



8. The equation  $a_0 (ax + b)^2 y'' + a_1(ax + b) y' + a_2y = \phi(x)$  is called  
 (a) Legendre's linear equation (b) Method of undetermined coefficients  
 (c) Cauchy's linear equation (d) Simultaneous equation [Ans. a]
9. The D.E.  $(ax + b)^2 y''$  is  
 (a)  $a^3 D (D - 1) (D - 2) y$  (b)  $a^2 D (D - 1) y$   
 (c)  $D \cdot Dy$  (d) None. [Ans. b]
10. The equation  $a_0 x^2 y'' + a_1 xy' + a_2y = \phi(x)$  is called  
 (a) Legendre's linear equation (b) Cauchy's linear equation  
 (c) Simultaneous equation (d) Method of undetermined coefficients.  
 [Ans. b]
11. If  $t = \log x$ , the value of  $x$  is  
 (a)  $e^t$  (b)  $e^x$   
 (c)  $xe^t$  (d)  $e^{xt}$ . [Ans. a]
12. The initial value problem,  $\frac{d^2x}{dt^2} + 5\frac{dx}{dt} + 6x = 0$   $x(0) = 0$  is  
 (a)  $C_1 - C_2 = 0$  (b)  $C_1 + C_2 = 0$   
 (c)  $C_1 = 0$  (d)  $C_2 = 0$  [Ans. b]
13.  $\frac{d^2y}{dx^2} + 4\frac{dy}{dx} + 3y = e^{-x}$ . Subject to the condition  $y(0) = 1$  is  
 (a)  $C_1 + C_2 = 1$  (b)  $C_1 + C_2 = 0$   
 (c)  $C_1 = 0$  (d)  $C_2 = -1$  [Ans. a]

□□□

## Laplace Transforms

### 7.1 INTRODUCTION

The Laplace transform method is used for solving the differential equations with initial and boundary conditions. The advantage of this method is that it solves the differential equations with initial conditions directly without the necessity of first finding the general solution and then evaluating the arbitrary constants using the initial conditions. In particular, this method is used in problems where the driving force (mechanical or electrical) has discontinuities for a short time or is periodic.

In this unit we study the basic concepts of Laplace transforms and its applications to solve the differential equations arising in mechanics, electrical circuits and bending of beams.

### 7.2 DEFINITION

Let  $f(t)$  be a real valued function defined for all  $t \geq 0$ . Then the Laplace transform of  $f(t)$  denoted by  $L\{f(t)\}$  is defined by

$$L\{f(t)\} = \int_0^{\infty} e^{-st} f(t) dt \quad \dots(1)$$

where  $s$  is a real or a complex number.

In the integral on the right hand side (1) exists, it is a function of  $s$  and is usually denoted by  $F(s)$ . Here  $s$  is called the parameter.

Thus,

$$F(s) = L\{f(t)\} = \int_0^{\infty} e^{-st} f(t) dt$$

### 7.3 PROPERTIES OF LAPLACE TRANSFORMS

If  $f(t)$  and  $g(t)$  are two functions defined for all positive values of  $t$  and  $k$  is a constant then

$$(1) L\{kf(t)\} = k L\{f(t)\}$$

$$(2) L\{f(t) + g(t)\} = L\{f(t)\} + L\{g(t)\}$$

**Proof:** (1) we have  $L\{f(t)\} = \int_0^{\infty} e^{-st} f(t) dt$

Therefore,

$$\begin{aligned} L\{kf(t)\} &= \int_0^{\infty} e^{-st} kf(t) dt \\ &= k \int_0^{\infty} e^{-st} f(t) dt \\ &= k L\{f(t)\} \end{aligned}$$

(2) Consider

$$\begin{aligned} L\{f(t) + g(t)\} &= \int_0^{\infty} e^{-st} \{f(t) + g(t)\} dt \\ &= \int_0^{\infty} e^{-st} f(t) dt + \int_0^{\infty} e^{-st} g(t) dt \\ &= L\{f(t)\} + L\{g(t)\}. \end{aligned}$$

### 7.3.1 Laplace Transforms of Some Standard Functions

#### 1. Laplace transform of a constant

Let  $f(t) = a$ , where  $a$  is constant. Then from the definition of Laplace transform, we get

$$\begin{aligned} L(a) &= \int_0^{\infty} e^{-st} a dt \\ &= a \int_0^{\infty} e^{-st} dt \\ &= a \left[ \frac{e^{-st}}{-s} \right]_0^{\infty} \\ &= \frac{-a}{s} [e^{-\infty} - e^0], \quad \text{since } e^{-\infty} = 0 \\ &\qquad\qquad\qquad e^0 = 1 \\ &= \frac{a}{s} \end{aligned}$$

Hence  $L(a) = \frac{a}{s}$  ... (2)

In particular cases,  $L(1) = \frac{1}{s}$ .

**2. Laplace transform of  $e^{at}$** 

Substituting  $f(t) = e^{at}$  in the definition of Laplace transform, we get

$$\begin{aligned} L(e^{at}) &= \int_0^{\infty} e^{-st} e^{at} dt \\ &= \int_0^{\infty} e^{(-s+a)t} dt \\ &= \left[ \frac{e^{-(s-a)t}}{-(s-a)} \right]_0^{\infty} \\ &= \frac{-1}{s-a} [e^{-\infty} - e^0] \\ &= \frac{1}{s-a} \text{ if } s > a > 0 \end{aligned}$$

$$\therefore L(e^{at}) = \frac{1}{s-a}, s > a > 0 \quad \dots(3)$$

Replacing  $a$  by  $-a$ , we get

$$L(e^{-at}) = \frac{1}{s+a}, s > -a. \quad \dots(4)$$

**3. Laplace transform of  $\sin h at$** 

We have  $\sin h at = \frac{e^{at} - e^{-at}}{2}$

Substituting  $f(t) = \sin h at = \frac{e^{at} - e^{-at}}{2}$

$$\begin{aligned} L(\sin h at) &= L\left\{ \frac{e^{at} - e^{-at}}{2} \right\} = \frac{1}{2} [L(e^{at}) - L(e^{-at})] \\ &= \frac{1}{2} \left\{ \frac{1}{s-a} - \frac{1}{s+a} \right\} \text{ By using, Eqns. (3) and (4)} \\ &= \frac{a}{s^2 - a^2}, \text{ if } s > a \end{aligned}$$

$$\text{Hence } L(\sin h at) = \frac{1}{s^2 - a^2}, s > a \quad \dots(5)$$

#### 4. Laplace transform of $\cos h at$

We have 
$$\cos h at = \frac{e^{at} + e^{-at}}{2}$$

Then 
$$\begin{aligned} L(\cos h at) &= L\left\{\frac{e^{at} + e^{-at}}{2}\right\} \\ &= \frac{1}{2}\{L(e^{at}) + L(e^{-at})\} \\ &= \frac{1}{2}\left\{\frac{1}{s-a} + \frac{1}{s+a}\right\} \\ &= \frac{s}{s^2 - a^2} \end{aligned}$$

using eqns. (3) and (4)

if  $s > a$

Thus, 
$$L(\cos h at) = \frac{s}{s^2 - a^2}, \quad s > a. \quad \dots(6)$$

#### 5. Laplace transform of $\sin at$ and $\cos at$

We know by Euler's formula that,

$$e^{iat} = \cos at + i \sin at$$

$$\therefore L(\cos at + i \sin at) = L\{e^{iat}\}$$

i.e., 
$$L(\cos at) + i L(\sin at) = \frac{1}{s - ia},$$
 Replacing  $a$  by  $ia$  in (3)

$$\begin{aligned} &= \frac{s + ia}{(s - ia)(s + ia)} \\ &= \frac{s + ia}{s^2 + a^2} \\ &= \frac{s}{s^2 + a^2} + i \frac{a}{s^2 + a^2} \end{aligned}$$

On equating the real and imaginary parts, we obtain

$$L(\cos at) = \frac{s}{s^2 + a^2} \quad \dots(7)$$

$$L(\sin at) = \frac{a}{s^2 + a^2}.$$

#### 6. Laplace transform of $t^n$

Let  $f(t) = t^n$ , where  $n$  is a non-negative real number or  $n$  is a negative non-integers. Then from the definition,

$$L(t^n) = \int_0^{\infty} e^{-st} t^n dt$$

Substitute  $st = x$ , so that  $dt = \frac{dx}{s}$  and

$$t = \frac{x}{s}$$

When  $t = 0, \quad x = 0$  and  
 $t = \infty, \quad x = \infty$

$$\begin{aligned} \therefore L(t^n) &= \int_0^{\infty} e^{-x} \left(\frac{x}{s}\right)^n \frac{dx}{s}, \\ &= \frac{1}{s^{n+1}} \int_0^{\infty} e^{-x} \cdot x^n dx \\ &= \frac{1}{s^{n+1}} \Gamma(n+1) \end{aligned}$$

Thus,  $L(t^n) = \frac{\Gamma(n+1)}{s^{n+1}} \quad \dots(8)$

In particular if  $n$  is a non-negative integer, we have

$$\Gamma(n+1) = n!$$

Hence,  $L(t^n) = \frac{n!}{s^{n+1}} \quad \dots(9)$

where  $n$  is a non-negative integer.

### Laplace transforms of some Standard Functions

	$f(t)$	$L\{f(t)\} = F(s)$		$f(t)$	$L\{f(t)\} = F(s)$
1.	$a$	$\frac{a}{s}, s > 0$	5.	$\cos h at$	$\frac{s}{s^2 - a^2}, s > a$
2.	$e^{at}$	$\frac{1}{s-a}, s > 0$	6.	$\sin at$	$\frac{a}{s^2 + a^2}, s > 0$
3.	$e^{-at}$	$\frac{1}{s+a}, s > -a$	7.	$\cos at$	$\frac{s}{s^2 + a^2}, s > 0$
4.	$\sin h at$	$\frac{a}{s^2 - a^2}, s > a$	8.	$t^n$ $n = 1, 2, 3, \dots$	$\frac{n!}{s^{n+1}}, s > 0$

### WORKED OUT EXAMPLES

1. Find the Laplace transform of the following functions:

- (1)  $2t^2 + 3t + 4$       (2)  $2e^{-3t} - 4e^{5t}$       (3)  $\sin^2 at$   
 (4)  $\cos^3 at$       (5)  $\sin 5t \cos 3t$       (6)  $\cos h^2 at$   
 (7)  $a^t$       (8)  $\cos t \cos 2t \cos 3t$ .

**Solution**

$$\begin{aligned}
 \text{(1) Now } L(2t^2 + 3t - 4) &= 2L(t^2) + 3L(t) + 4L(1) \\
 &= 2 \cdot \frac{2!}{s^3} + 3 \frac{1}{s^2} + 4 \frac{1}{s} \\
 &= \frac{4 + 3s + 4s^2}{s^3}
 \end{aligned}$$

$$\begin{aligned}
 \text{(2) } L(2e^{-3t} - 4e^{5t}) &= 2L(e^{-3t}) - 4L(e^{+5t}) \\
 &= 2 \frac{1}{s+3} - 4 \frac{1}{s-5} \\
 &= \frac{-2(s+11)}{(s+3)(s-5)}
 \end{aligned}$$

$$\begin{aligned}
 \text{(3) } L(\sin^2 at) &= L\left(\frac{1 - \cos 2at}{2}\right) \\
 &= \frac{1}{2} L(1 - \cos 2at) \\
 &= \frac{1}{2} [L(1) - L(\cos 2at)] \\
 &= \frac{1}{2} \left[ \frac{1}{s} - \frac{s}{s^2 + (2a)^2} \right] \\
 &= \frac{1}{2} \left[ \frac{s^2 + 4a^2 - s^2}{s(s^2 + 4a^2)} \right] \\
 &= \frac{2a^2}{s(s^2 + 4a^2)}
 \end{aligned}$$

$$\text{(4) we know that } \cos 3at = 4 \cos^3 at - 3 \cos at$$

$$\therefore \cos^3 at = \frac{1}{4} (\cos 3at + 3 \cos at)$$

$$\begin{aligned}
 \text{Thus, } L(\cos^3 at) &= L\left[\frac{1}{4} (\cos 3at + 3 \cos at)\right] \\
 &= \frac{1}{4} [L(\cos 3at) + 3 L(\cos at)] \\
 &= \frac{1}{4} \left[ \frac{s}{s^2 + (3a)^2} + \frac{3s}{s^2 + a^2} \right] \\
 &= \frac{s(s^2 + 7a^2)}{(s^2 + 9a^2)(s^2 + a^2)}.
 \end{aligned}$$

$$\begin{aligned} \text{(5) Since, } \sin 5t \cos 3t &= \frac{1}{2} [\sin(5t + 3t) + \sin(5t - 3t)] \\ &= \frac{1}{2} [\sin 8t + \sin 2t] \end{aligned}$$

$$\begin{aligned} \text{Therefore, } L(\sin 5t \cos 3t) &= L\left\{\frac{1}{2}[\sin 8t + \sin 2t]\right\} \\ &= \frac{1}{2}\{L(\sin 8t) + L(\sin 2t)\} \\ &= \frac{1}{2}\left[\frac{8}{s^2 + 8^2} + \frac{2}{s^2 + 2^2}\right] \\ &= \frac{5(s^2 + 16)}{(s^2 + 64)(s^2 + 4)} \end{aligned}$$

$$\text{(6) We have, } \cos h 2at = 2 \cos h^2 at - 1$$

$$\text{So that, } \cos h^2 at = \frac{1}{2}(1 + \cosh 2at)$$

$$\begin{aligned} \text{Hence, } L[\cos h^2 at] &= \frac{1}{2}\{L(1) + L[\cosh 2at]\} \\ &= \frac{1}{2}\left\{\frac{1}{s} + \frac{s}{s^2 - (2a)^2}\right\} \\ &= \frac{s^2 - 2a^2}{s(s^2 - 4a^2)}. \end{aligned}$$

$$\text{(7) we have } a^t = e^{t \log a}, \quad a > 0$$

$$\text{Hence, } L(a^t) = L\{e^{t \log a}\} = \frac{1}{s - \log a}.$$

$$\begin{aligned} \text{(8) We have } \cos t \cos 2t \cos 3t &= \frac{1}{2} \cos t (\cos 5t + \cos t) \\ &= \frac{1}{2} [\cos 5t \cos t + \cos^2 t] \\ &= \frac{1}{2} \left[ \frac{1}{2} (\cos 6t + \cos 4t) + \frac{1}{2} (1 + \cos 2t) \right] \\ &= \frac{1}{4} (\cos 6t + \cos 4t) + \frac{1}{4} (1 + \cos 2t) \\ &= \frac{1}{4} [1 + \cos 2t + \cos 4t + \cos 6t] \end{aligned}$$



Therefore,

$$\begin{aligned} L(\cos t \cos 2t \cos 3t) &= \frac{1}{4} [L(1) + L(\cos 2t) + L(\cos 4t) + L(\cos 6t)] \\ &= \frac{1}{4} \left[ \frac{1}{s} + \frac{s}{s^2 + 2^2} + \frac{s}{s^2 + 4^2} + \frac{s}{s^2 + 6^2} \right]. \end{aligned}$$

2. Find the Laplace transforms of the functions,

$$(1) \sqrt{t} \qquad (2) \frac{1}{\sqrt{t}} \qquad (3) t\sqrt{t}.$$

**Solution**

$$(1) \text{ We have } L(t^n) = \frac{\Gamma(n+1)}{s^{n+1}}$$

$$\begin{aligned} \therefore L(\sqrt{t}) &= L\left(t^{\frac{1}{2}}\right) = \frac{\Gamma\left(\frac{1}{2} + 1\right)}{s^{\frac{1}{2} + 1}} \\ &= \frac{\frac{1}{2} \Gamma\left(\frac{1}{2}\right)}{s^{\frac{3}{2}}} = \frac{\sqrt{\pi}}{2s^{\frac{3}{2}}} \end{aligned}$$

$$\text{Since } \Gamma(n+1) = n \Gamma(n) \text{ and } \Gamma\left(\frac{1}{2}\right) = \sqrt{\pi}.$$

$$\begin{aligned} (2) \text{ Now } L\left(\frac{1}{\sqrt{t}}\right) &= L\left(t^{-\frac{1}{2}}\right) = \frac{\Gamma\left(-\frac{1}{2} + 1\right)}{s^{-\frac{1}{2} + 1}} \\ &= \frac{\Gamma\left(\frac{1}{2}\right)}{s^{\frac{1}{2}}} = \frac{\sqrt{\pi}}{\sqrt{s}} \end{aligned}$$

$$\begin{aligned} (3) \quad L(t\sqrt{t}) &= L\left(t^{\frac{3}{2}}\right) = \frac{\Gamma\left(\frac{3}{2} + 1\right)}{s^{\frac{3}{2} + 1}} \\ &= \frac{\frac{3}{2} \cdot \frac{1}{2} \Gamma\left(\frac{1}{2}\right)}{s^{\frac{5}{2}}} \\ &= \frac{3\sqrt{\pi}}{4 \cdot s^{\frac{5}{2}}}. \end{aligned}$$

3. If  $f(t) = \begin{cases} 2, & 0 < t < 3 \\ t, & t > 3 \end{cases}$ , find  $L\{f(t)\}$ .

**Solution.** Now, 
$$\begin{aligned} L\{f(t)\} &= \int_0^{\infty} e^{-st} f(t) dt \\ &= \int_0^3 e^{-st} \cdot 2 dt + \int_3^{\infty} e^{-st} \cdot t dt \\ &= 2 \left[ \frac{e^{-st}}{-s} \right]_0^3 + \left[ t \frac{e^{-st}}{-s} - 1 \cdot \frac{e^{-st}}{(-s)^2} \right]_3^{\infty} \\ &= \frac{-2}{s} [e^{-3s} - 1] + 0 - \left[ -\frac{3e^{-2s}}{s} - \frac{e^{-3s}}{s^2} \right] \\ &= \frac{2}{s} + \frac{s+1}{s^2} \cdot e^{-3s}. \end{aligned}$$

4. If  $f(t) = \begin{cases} 1, & 0 < t < 2 \\ t, & 2 < t < 4 \\ t^2, & t > 4 \end{cases}$ , find  $L\{f(t)\}$ .

**Solution.** We have,

$$\begin{aligned} L\{f(t)\} &= \int_0^{\infty} e^{-st} f(t) dt \\ &= \int_0^2 e^{-st} \cdot 1 \cdot dt + \int_2^4 e^{-st} \cdot t dt + \int_4^{\infty} e^{-st} \cdot t^2 \cdot dt \\ &= \left[ \frac{e^{-st}}{-s} \right]_0^2 + \left[ t \frac{e^{-st}}{-s} - \frac{e^{-st}}{(-s)^2} \right]_2^4 + \left[ t^2 \frac{e^{-st}}{-s} - 2t \frac{e^{-st}}{(-s)^2} + 2 \frac{e^{-st}}{(-s)^3} \right]_4^{\infty} \\ &= \frac{-1}{s} (e^{-2s} - 1) - e^{-4s} \left( \frac{4}{s} + \frac{1}{s^2} \right) + e^{-2s} \left( \frac{2}{s} + \frac{1}{s^2} \right) + e^{-4s} \left( \frac{16}{s} + \frac{8}{s^2} + \frac{2}{s^3} \right) \\ &= \frac{1}{s} + \left( \frac{1}{s} + \frac{1}{s^2} \right) e^{-2s} + \left( \frac{12}{s} + \frac{7}{s^2} + \frac{2}{s^3} \right) e^{-4s}. \end{aligned}$$

5. If  $L\{f(t)\} = F(s)$ . Prove that  $L\{f(at)\} = \frac{1}{a} F\left(\frac{s}{a}\right)$ .

**Solution.** Now, 
$$L\{f(at)\} = \int_0^{\infty} e^{-st} f(at) dt$$

Substitute 
$$at = u \text{ or } t = \frac{u}{a}$$

Hence,

$$dt = \frac{du}{a}$$

When,

$$t = 0, u = 0 \text{ and } t = \infty, u = \infty$$

$\therefore$

$$\begin{aligned} L\{f(at)\} &= \int_0^{\infty} e^{\frac{-su}{a}} \cdot f(u) \cdot \frac{du}{a} \\ &= \frac{1}{a} \int_0^{\infty} e^{\frac{-su}{a}} \cdot f(u) du \\ &= \frac{1}{a} \int_0^{\infty} e^{\left(\frac{-s}{a}\right)u} \cdot f(u) du \\ &= \frac{1}{a} F\left(\frac{s}{a}\right). \end{aligned}$$

### EXERCISE 7.1

Find the Laplace transforms of the following functions:

- |                        |  |                        |   |
|------------------------|--|------------------------|---|
| 1. $2t^2 + 3$          | $\left[ \text{Ans. } \frac{3s^2 + 4}{s^3} \right]$             | 2. $4t^2 - 5t + 6.$    | $\left[ \text{Ans. } \frac{8 - 5s + 6s^2}{s^3} \right]$               |
| 3. $(2t - 3)^2$        | $\left[ \text{Ans. } \frac{8 - 12s + 9s^2}{s^3} \right]$       | 4. $(2t - 1)^3.$       | $\left[ \text{Ans. } \frac{1}{s^4} [48 - 24s + 6s^2 - s^3] \right]$   |
| 5. $5^t.$              | $\left[ \text{Ans. } \frac{1}{s - \log 5} \right]$             | 6. $(1 + e^t)^2.$      | $\left[ \text{Ans. } \frac{2(2s^2 - 4s + 1)}{s(s-1)(s-2)} \right]$    |
| 7. $\cos^2 at.$        | $\left[ \text{Ans. } \frac{s^2 + 2a^2}{s(s^2 + 4a^2)} \right]$ | 8. $\sin^3 at.$        | $\left[ \text{Ans. } \frac{6a^3}{(s^2 + a^2)(s^2 + 9a^2)} \right]$    |
| 9. $\sin h^2 at.$      | $\left[ \text{Ans. } \frac{2a^2}{s(s^2 - 4a^2)} \right]$       | 10. $\sin 3t \cos 2t.$ | $\left[ \text{Ans. } \frac{s^2 + 15}{(s^2 + 25)(s^2 + 1)} \right]$    |
| 11. $\cos 5t \cos 2t.$ |  |                        | $\left[ \text{Ans. } \frac{s(s^2 + 29)}{(s^2 + 49)(s^2 + 9)} \right]$ |
| 12. $\sin 6t \sin 4t.$ |  |                        | $\left[ \text{Ans. } \frac{48s}{(s^2 + 4)(s^2 + 100)} \right]$        |

$$13. \cos 8t \sin 2t. \quad \left[ \text{Ans. } \frac{2(s^2 - 60)}{(s^2 + 100)(s^2 + 36)} \right]$$

$$14. \cos(at + b). \quad \left[ \text{Ans. } \frac{s \cos b - a \sin b}{s^2 + a^2} \right]$$

$$15. \sin t \sin 2t \sin 3t. \quad \left[ \text{Ans. } \frac{1}{2} \left[ \frac{1}{s^2 + 4} - \frac{3}{s^2 + 36} + \frac{2}{s^2 + 16} \right] \right]$$

Find  $L\{f(t)\}$ , in each of the following functions:

$$1. f(t) = \begin{cases} 5, & 0 < t < 3 \\ 0, & t > 3 \end{cases} \quad \left[ \text{Ans. } \frac{2(1 - e^{-3s})}{s} \right]$$

$$2. f(t) = \begin{cases} 1, & 0 < t < 2 \\ t, & t > 2 \end{cases} \quad \left[ \text{Ans. } \frac{1}{s} + \frac{1}{s^2} (1 + s) e^{-2s} \right]$$

$$3. f(t) = \begin{cases} 1, & 0 < t < 2 \\ 2, & 2 < t < 4 \\ 3, & t > 4 \end{cases} \quad \left[ \text{Ans. } \frac{1}{s} (1 + e^{-2s} + e^{-4s}) \right]$$

$$4. f(t) = \begin{cases} e^t, & 0 < t < 1 \\ 0, & t > 1 \end{cases} \quad \left[ \text{Ans. } \frac{e^{1-s} - 1}{1 - s} \right]$$

$$5. f(t) = \begin{cases} 0, & 0 < t < 1 \\ t, & 1 < t < 2 \\ 0, & t > 2 \end{cases} \quad \left[ \text{Ans. } \frac{1}{s^2} \{ (s+1)e^{-s} - (2s+1)e^{-2s} \} \right]$$

$$6. f(t) = \begin{cases} \cos at, & 0 \leq t \leq \pi \\ 0, & t > \pi \end{cases} \quad \left[ \text{Ans. } \frac{s + (-s \cos a \pi + a \sin a \pi) e^{-\pi s}}{s^2 + a^2} \right]$$

$$7. f(t) = \begin{cases} \cos\left(t - \frac{2\pi}{3}\right), & t > \frac{2\pi}{3} \\ 0, & 0 < t < \frac{2\pi}{3} \end{cases} \quad \left[ \text{Ans. } \frac{s e^{\frac{-2\pi s}{3}}}{s^2 + 1} \right]$$

### 7.3.2 Laplace Transforms of the form $e^{at} f(t)$

If the Laplace transform of  $f(t)$  is known, then the Laplace transform of  $e^{at} f(t)$  where  $a$  is a constant can be determined by using the shifting property.

**Shifting property:**

If  $L\{f(t)\} = F(s)$  then

$$L\{e^{at} f(t)\} = F(s-a)$$

**Proof:** We have  $L\{f(t)\} = \int_0^{\infty} e^{-st} f(t) dt = F(s)$

$$\begin{aligned} \text{Therefore, } L\{e^{at} f(t)\} &= \int_0^{\infty} e^{-st} e^{at} f(t) dt \\ &= \int_0^{\infty} e^{-(s-a)t} f(t) dt = F(s-a). \end{aligned}$$

Replacing  $a$  by  $-a$ ,

$$\text{We get, } L\{e^{-at} f(t)\} = F(s+a)$$

In view of the shifting property we can find the Laplace transform of the standard functions discussed in the preceding section multiplied by  $e^{at}$  or  $e^{-at}$

1.  $L(\sin bt) = \frac{b}{s^2 + b^2}, \quad L(e^{at} \sin bt) = \frac{b}{(s-a)^2 + b^2}$
2.  $L(\cos bt) = \frac{s}{s^2 + b^2}, \quad L(e^{at} \cos bt) = \frac{s-a}{(s-a)^2 + b^2}$
3.  $L(\sin h bt) = \frac{b}{s^2 - b^2}, \quad L(e^{at} \sin h bt) = \frac{b}{(s-a)^2 - b^2}$
4.  $L(\cos h bt) = \frac{s}{s^2 - b^2}, \quad L(e^{at} \cos h bt) = \frac{s-a}{(s-a)^2 - b^2}$
5.  $L(t^n) = \frac{\Gamma(n+1)}{s^{n+1}}, \quad L(e^{at} t^n) = \frac{\Gamma(n+1)}{(s-a)^{n+1}}, \text{ for } n = 0.$

**WORKED OUT EXAMPLES**

$$1. \text{ If } f(t) = \begin{cases} \cos\left(t - \frac{2\pi}{3}\right), & t > \frac{2\pi}{3} \\ 0, & 0 < t < \frac{2\pi}{3} \end{cases}, \text{ find } L\{f(t)\}.$$

**Solution**

$$\Rightarrow \text{We have, } L(\cos t) = \frac{s}{s^2 + 1}$$

By using shifting Rule  $a = \frac{2\pi}{3}$

$$L\{f(t)\} = e^{\frac{-2\pi s}{3}} \cdot \frac{s}{s^2 + 1} = \frac{s e^{\frac{-2\pi s}{3}}}{s^2 + 1}.$$

2. Find the Laplace transform of the following functions

(1)  $t^2 e^{2t}$                       (2)  $e^{-3t} \sin 2t$                       (3)  $e^{4t} \cos h 3t$

(4)  $e^{-t} \cos^2 3t$                       (5)  $e^{3t} \sin^3 2t$                       (6)  $\sqrt{t} e^t$ .

**Solution**

(1) We have  $L(t^2) = \frac{2}{s^3}$

By using the shifting property, we get

$$L(t^2 e^{2t}) = \frac{2}{(s-2)^3} \quad (s \rightarrow s-2)$$

(2) Since,  $L(\sin 2t) = \frac{2}{s^2 + 2^2}$

$$\begin{aligned} L(e^{-3t} \sin 2t) &= \frac{2}{(s+3)^2 + 4} && (s \rightarrow s+3) \\ &= \frac{2}{s^2 + 6s + 13} \end{aligned}$$

(3)  $L(\cos h 3t) = \frac{s}{s^2 - 3^2}$

$$\begin{aligned} L(e^{4t} \cos h 3t) &= \frac{s-4}{(s-4)^2 - 9} && (s \rightarrow s-4) \\ &= \frac{s-4}{s^2 - 8s + 7}. \end{aligned}$$

(4) Consider  $L(\cos^2 3t) = L\left(\frac{1 + \cos 6t}{2}\right)$

$$= \frac{1}{2} [L(1) + L(\cos 6t)]$$

$$= \frac{1}{2} \left[ \frac{1}{s} + \frac{s}{s^2 + 6^2} \right]$$

$$= \frac{s^2 + 18}{s(s^2 + 36)}$$

$$\begin{aligned} \therefore L(e^{-t} \cos^2 3t) &= \frac{(s+1)^2 + 18}{(s+1)[(s+1)^2 + 36]} && (s \rightarrow s+1) \\ &= \frac{s^2 + 2s + 19}{(s+1)(s^2 + 2s + 37)}. \end{aligned}$$

(5) We have  $\sin^3 A = \frac{1}{4}(3 \sin A - \sin 3A)$

Hence  $\sin^3 2t = \frac{1}{4}(3 \sin 2t - \sin 6t)$

$$\begin{aligned} L(\sin^3 2t) &= \frac{1}{4}[3L(\sin 2t) - L(\sin 6t)] \\ &= \frac{1}{4}\left[3 \cdot \frac{2}{s^2 + 2^2} - \frac{6}{s^2 + 6^2}\right] \\ &= \frac{48}{(s^2 + 4)(s^2 + 36)} \end{aligned}$$

By using shifting Rule, we get,  $s \rightarrow s - 3$

$$\begin{aligned} L\{e^{3t} \sin^3 2t\} &= \frac{48}{[(s-3)^2 + 4][(s-3)^2 + 36]} \\ &= \frac{48}{(s^2 - 6s + 13)(s^2 - 6s + 45)} \end{aligned}$$

(6) Now  $L(\sqrt{t}) = \frac{\Gamma\left(\frac{1}{2} + 1\right)}{s^{\frac{1}{2} + 1}} = \frac{\frac{1}{2} \Gamma \frac{1}{2}}{s^{\frac{3}{2}}} = \frac{\sqrt{\pi}}{2s^{\frac{3}{2}}}$

Hence  $L(\sqrt{t} e^t) = \frac{\sqrt{\pi}}{2(s-1)^{\frac{3}{2}}}$ . ( $s \rightarrow s+1$ )

3. If  $L\{f(t)\} = F(s)$ ,

Prove that (1)  $L\{\cosh at f(t)\} = \frac{1}{2}[F(s-a) + F(s+a)]$

(2)  $L\{\sinh at f(t)\} = \frac{1}{2}[F(s-a) - F(s+a)]$

**Solution**

(1) Consider  $L\{\cosh at f(t)\} = L\left\{\left[\frac{e^{at} + e^{-at}}{2}\right]f(t)\right\}$

$$= \frac{1}{2} \left[ L \{ e^{at} f(t) \} + L \{ e^{-at} f(t) \} \right]$$

By using shifting property

$$= \frac{1}{2} [F(s-a) + F(s+a)].$$

$$\begin{aligned} \text{(2) Consider, } L \{ \sin h at f(t) \} &= L \left\{ \left[ \frac{e^{at} - e^{-at}}{2} \right] f(t) \right\} \\ &= \frac{1}{2} [L \{ e^{at} f(t) \} - L \{ e^{-at} f(t) \}] \\ &= \frac{1}{2} [F(s-a) - F(s+a)]. \end{aligned}$$

## EXERCISE 7.2

Find the Laplace transforms of the following functions:

- |                                |  |                          |   |
|--------------------------------|--|--------------------------|---|
| 1. $te^{-2t}$ .                | $\left[ \text{Ans. } \frac{1}{(s+2)^2} \right]$                      | 2. $(t^2 + 4)e^{3t}$ .   | $\left[ \text{Ans. } \frac{2(2s^2 - 12s + 19)}{(s-3)^2} \right]$                      |
| 3. $e^{2t} \sin 3t$ .          | $\left[ \text{Ans. } \frac{3}{s^2 - 4s + 13} \right]$                | 4. $e^{4t} \cos 4t$ .    | $\left[ \text{Ans. } \frac{s-4}{s^2 - 8s + 32} \right]$                               |
| 5. $e^{-2t} \sin h 3t$ .       | $\left[ \text{Ans. } \frac{3}{s^2 + 4s - 5} \right]$                 | 6. $e^{5t} \cos h 2t$ .  | $\left[ \text{Ans. } \frac{s-5}{s^2 - 10s + 21} \right]$                              |
| 7. $e^t \sin^2 t$ .            | $\left[ \text{Ans. } \frac{2}{(s-1)(s^2 - 2s + 5)} \right]$          | 8. $e^{-4t} \cos^2 t$ .  | $\left[ \text{Ans. } \frac{s^2 + 8s + 18}{(s+4)(s^2 + 8s + 20)} \right]$              |
| 9. $e^{2t} \sin^3 t$ .         |  |                          | $\left[ \text{Ans. } \frac{6}{(s^2 - 4s + 5)(s^2 - 4s + 13)} \right]$                 |
| 10. $e^{2t} \cos 5t \sin 2t$ . |  |                          | $\left[ \text{Ans. } \frac{2(s^2 - 4s - 17)}{(s^2 - 4s + 53)(s^2 - 4s + 13)} \right]$ |
| 11. $\frac{e^t}{\sqrt{t}}$ .   | $\left[ \text{Ans. } \frac{\sqrt{\pi}}{(s-1)^{\frac{1}{2}}} \right]$ | 12. $e^{at} \cos^2 bt$ . | $\left[ \text{Ans. } \frac{(s-a)^2 + 2b^2}{(s-a)[(s-a)^2 + b^2]} \right]$             |



### 7.3.3 Laplace Transforms of the form $t^n f(t)$ where $n$ is a positive integer

In this section we shall find the Laplace transforms of the functions of the form  $t^n f(t)$  where  $n$  is a positive integer if the Laplace transform of  $f(t)$  is known.

**Theorem:** If  $L\{f(t)\} = F(s)$  then

$$L\{t^n f(t)\} = (-1)^n \frac{d^n}{ds^n} \{F(s)\}$$

**Proof:** We shall prove the theorem for  $n = 1$

$$\text{i.e.,} \quad L\{t f(t)\} = -\frac{d}{ds} \{F(s)\}$$

$$\text{We have,} \quad F(s) = L\{f(t)\} = \int_0^{\infty} e^{-st} f(t) dt$$

Differentiating w.r.t. 's', we get

$$\frac{d}{ds} \{F(s)\} = \int_0^{\infty} \frac{d}{ds} \{e^{-st} f(t)\} dt$$

In the R.H.S., we shall apply Leibnitz rule for differentiation under the integral sign,

$$\begin{aligned} &= \int_0^{\infty} e^{-st} (-t) f(t) dt \\ &= -\int_0^{\infty} e^{-st} \{t f(t)\} dt. \\ &= -L\{t f(t)\} \end{aligned}$$

$$\therefore L\{t f(t)\} = \frac{-d}{ds} \{F(s)\} = \frac{-d}{ds} [L\{f(t)\}]$$

$$\text{Further,} \quad L\{t^2 f(t)\} = L\{t[t f(t)]\} = \frac{-d}{ds} L\{t f(t)\}$$

$$\begin{aligned} &= \frac{-d}{ds} \left[ \frac{-d}{ds} L\{f(t)\} \right] \\ &= (-1)^2 \frac{d^2}{ds^2} L\{f(t)\} \\ &= (-1)^2 \frac{d^2}{ds^2} \{F(s)\} \end{aligned}$$

By repeated this process of the above theorem, we get

$$L\{t^n f(t)\} = (-1)^n \cdot \frac{d^n}{ds^n} \{F(s)\}.$$

### 7.3.4 Laplace Transforms of $\frac{f(t)}{t}$

If  $L f(t)$  is known then we can find the Laplace transform of  $\frac{f(t)}{t}$  by using the following.

**Theorem:** If  $L \{f(t)\} = F(s)$  and  $\lim_{t \rightarrow 0} \frac{f(t)}{t}$  exists then

$$L \left\{ \frac{f(t)}{t} \right\} = \int_s^{\infty} F(s) ds \quad \dots(1)$$

**Proof:** We have,  $F(s) = L \{f(t)\} = \int_0^{\infty} e^{-st} f(t) dt$

On integrating both sides w.r.t.  $s$  from  $s$  to  $\infty$ , we get

$$\int_s^{\infty} F(s) ds = \int_s^{\infty} \left[ \int_0^{\infty} e^{-st} f(t) dt \right] ds \quad \dots(2)$$

$$= \int_0^{\infty} \left[ \int_s^{\infty} e^{-st} ds \right] f(t) dt, \quad \dots(3)$$

(By changing the order of integration.)

$$\text{Now } \int_s^{\infty} e^{-st} ds = \left[ \frac{-e^{-st}}{-t} \right]_s^{\infty} = \frac{-1}{t} [e^{-\infty} - e^{-st}] = \frac{+e^{-st}}{t} \quad (e^{-\infty} = 0)$$

$\therefore$  Eqn. (3) gives,

$$\int_s^{\infty} F(s) ds = \int_0^{\infty} \frac{e^{-st}}{t} f(t) dt = L \left\{ \frac{f(t)}{t} \right\}$$

$$\therefore \int_s^{\infty} F(s) ds = L \left\{ \frac{f(t)}{t} \right\}$$

This completes the proof.

## WORKED OUT EXAMPLES

1. Find the Laplace transforms of the following functions:

(1)  $t \sin at$

(2)  $t \cos at$

(3)  $t \sin h at$

(4)  $t \cos h at$

(5)  $t^2 \cos at$

(6)  $t e^t \sin h t$

(7)  $t e^{-2t} \cos 2t$

(8)  $t^3 \sin t$ .

**Solution**

(1)  $L \{t \sin at\} = \frac{-d}{ds} L(\sin at)$

$$= \frac{-d}{ds} \left\{ \frac{a}{s^2 + a^2} \right\}$$

$$= \frac{2as}{(s^2 + a^2)^2}.$$

$$(2) \quad L \{t \cos at\} = \frac{-d}{ds} L(\cos at)$$

$$= \frac{-d}{ds} \left\{ \frac{s}{s^2 + a^2} \right\}$$

$$= \frac{s^2 - a^2}{(s^2 + a^2)^2}.$$

$$(3) \quad L \{t \sin h at\} = \frac{-d}{ds} L(\sin h at)$$

$$= \frac{-d}{ds} \left\{ \frac{a}{s^2 - a^2} \right\}$$

$$= \frac{2as}{(s^2 - a^2)^2}.$$

$$(4) \quad L \{t \cos h at\} = \frac{-d}{ds} L(\cos h at)$$

$$= \frac{-d}{ds} \left\{ \frac{s}{s^2 - a^2} \right\}$$

$$= \frac{(s^2 + a^2)}{(s^2 - a^2)^2}.$$

$$(5) \quad L(t^2 \cos at) = (-1)^2 \cdot \frac{d^2}{ds^2} \{L(\cos at)\}$$

$$= +1 \frac{d^2}{ds^2} \left\{ \frac{s}{s^2 + a^2} \right\}$$

$$= \frac{-2s(3a^2 - s^2)}{(s^2 + a^2)^3}$$

$$L \{t^2 \cos at\} = \frac{-2s(3a^2 - s^2)}{(s^2 + a^2)^3}.$$

$$\begin{aligned}
 (6) \quad L \{t \sin h t\} &= \frac{-d}{ds} \{L(\sin h t)\} \\
 &= \frac{-d}{ds} \left\{ \frac{1}{s^2 - 1} \right\} \\
 &= \frac{2s}{(s^2 - 1)^2} \\
 L(e^t t \sin h t) &= \frac{2(s-1)}{[(s-1)^2 - 1]^2} && s \rightarrow s - 1 \\
 &= \frac{2(s-1)}{s^2 (s-2)^2}.
 \end{aligned}$$

(7) From Eqn. (2) above with  $a = 2$ , we have

$$L(t \cos 2t) = \frac{s^2 - 4}{(s^2 + 4)^2}$$

Hence by using shifting Rule, we get  $s \rightarrow s + 2$

$$\begin{aligned}
 L\{e^{-2t} t \cos 2t\} &= \frac{(s+2)^2 - 4}{[(s+2)^2 + 4]^2} \\
 &= \frac{s(s+4)}{(s^2 + 4s + 8)^2}.
 \end{aligned}$$

(8) we have  $L(\sin t) = \frac{1}{s^2 + 1}$

$$\begin{aligned}
 \therefore L(t^3 \sin t) &= (-1)^3 \cdot \frac{d^3}{ds^3} \left\{ \frac{1}{s^2 + 1} \right\} \\
 &= \frac{24s(s^2 - 1)}{(s^2 + 1)^4}.
 \end{aligned}$$

2. Prove that  $\int_0^{\infty} e^{-3t} t \sin t dt = \frac{3}{50}$ .

**Solution**

$$\Rightarrow \text{We have } \int_0^{\infty} e^{-st} t \sin t dt = L(t \sin t) = F(s)$$

Now,  $F(s) = L(t \sin t) = \frac{-d}{ds} \{L(\sin t)\}$

$$= \frac{-d}{ds} \left\{ \frac{1}{s^2 + 1} \right\}$$

$$= \frac{2s}{(s^2 + 1)^2}$$

$$\therefore \int_0^{\infty} e^{-3t} t \sin t dt = F(3) = \frac{2 \cdot 3}{(3^2 + 1)^2} = \frac{6}{100} = \frac{3}{50}.$$

3. Prove that  $\int_0^{\infty} t e^{-2t} \sin 3t dt = \frac{12}{169}$ .

**Solution:**

$$\Rightarrow \text{We have } \int_0^{\infty} e^{-st} t \sin 3t dt = L(t \sin 3t) = F(s)$$

$$\text{Now, } F(s) = L(t \sin 3t) = \frac{-d}{ds} \{L(\sin 3t)\}$$

$$= \frac{-d}{ds} \left\{ \frac{3}{s^2 + 9} \right\}$$

$$= \frac{6s}{(s^2 + 9)^2}$$

Given the integral,

$$F(2) = \frac{6 \cdot 2}{(2^2 + 9)^2} = \frac{12}{169}.$$

4. Find the Laplace transforms of the following functions:

(1)  $\frac{\sin at}{t}$

(2)  $\frac{1 - e^{at}}{t}$

(3)  $\frac{1 - \cos at}{t}$

(4)  $\frac{\cos at - \cos bt}{t}$

(5)  $\frac{e^{-at} - e^{-bt}}{t}$

(6)  $\frac{\sin h at}{t}$ .

**Solution**

(1) Now  $\lim_{t \rightarrow 0} \frac{\sin at}{t} = a \left[ \because \lim_{t \rightarrow 0} \left( \frac{\sin at}{at} \right) \cdot a = a \right]$  and

$$L(\sin at) = \frac{a}{s^2 + a^2}$$

$$L\left\{ \frac{\sin at}{t} \right\} = \int_s^{\infty} \frac{a}{s^2 + a^2} ds$$

$$= \left[ \tan^{-1} \left( \frac{s}{a} \right) \right]_s^{\infty}$$

$$\begin{aligned}
 &= \tan^{-1} \infty - \tan^{-1} \left( \frac{s}{a} \right) \\
 &= \frac{\pi}{2} - \tan^{-1} \left( \frac{s}{a} \right) \\
 &= \cot^{-1} \left( \frac{s}{a} \right).
 \end{aligned}$$

(2) Now  $\lim_{t \rightarrow 0} \frac{1 - e^{at}}{t} = \lim_{t \rightarrow 0} \frac{-ae^{at}}{1} = -a$  (By using L' Hospital Rule)

Also,  $L(1 - e^{at}) = L(1) - L(e^{at})$

$$= \frac{1}{s} - \frac{1}{s-a}$$

$$\begin{aligned}
 L \left\{ \frac{1 - e^{at}}{t} \right\} &= \int_s^\infty \left( \frac{1}{s} - \frac{1}{s-a} \right) ds \\
 &= \left[ \log s - \log(s-a) \right]_s^\infty \\
 &= \left[ \log \left( \frac{s}{s-a} \right) \right]_s^\infty \\
 &= \left[ \log \left( \frac{1}{1 - \left( \frac{a}{s} \right)} \right) \right]_s^\infty \\
 &= \log 1 - \log \left[ \frac{1}{1 - \left( \frac{a}{s} \right)} \right] \\
 &= -\log \frac{s}{s-a} \\
 &= \log \left( \frac{s-a}{s} \right).
 \end{aligned}$$

(3) Consider  $\lim_{t \rightarrow 0} \frac{1 - \cos at}{t} = \lim_{t \rightarrow 0} \frac{a \sin at}{1} = 0$  (By using L' Hospital Rule)

We have  $L(1 - \cos at) = L(1) - L(\cos at)$

$$= \frac{1}{s} - \frac{s}{s^2 + a^2}$$

$$L \left\{ \frac{1 - \cos at}{t} \right\} = \int_s^\infty \left( \frac{1}{s} - \frac{s}{s^2 + a^2} \right) ds$$

$$\begin{aligned}
&= \left[ \log s - \frac{1}{2} \log (s^2 + a^2) \right]_s^\infty \\
&= \frac{1}{2} \log \frac{s^2}{s^2 + a^2} \Bigg|_s^\infty \\
&= \frac{1}{2} \log \frac{1}{1 + \frac{a^2}{s^2}} \Bigg|_s^\infty \\
&= \frac{1}{2} \left\{ \log 1 - \log \frac{1}{1 + \frac{a^2}{s^2}} \right\} \\
&= \frac{-1}{2} \log \frac{s^2}{s^2 + a^2} = \frac{1}{2} \log \frac{s^2 + a^2}{s^2}.
\end{aligned}$$

(4) Let  $f(t) = \cos at - \cos bt$

Now, 
$$\begin{aligned}
\lim_{t \rightarrow 0} \frac{f(t)}{t} &= \lim_{t \rightarrow 0} \frac{\cos at - \cos bt}{t} \\
&= \lim_{t \rightarrow 0} \frac{-a \sin at + b \sin bt}{1} \\
&= 0
\end{aligned}$$

(Using L' Hospital Rule)

Now  $L \{ \cos at - \cos bt \} = \frac{s}{s^2 + a^2} - \frac{s}{s^2 + b^2}$

$$\begin{aligned}
L \left\{ \frac{\cos at - \cos bt}{t} \right\} &= \int_s^\infty \left[ \frac{s}{s^2 + a^2} - \frac{s}{s^2 + b^2} \right] ds \\
&= \left[ \frac{1}{2} \log (s^2 + a^2) - \frac{1}{2} \log (s^2 + b^2) \right]_s^\infty \\
&= \frac{1}{2} \log \frac{s^2 + a^2}{s^2 + b^2} \Bigg|_s^\infty \\
&= \frac{1}{2} \log \frac{1 + \frac{a^2}{s^2}}{1 + \frac{b^2}{s^2}} \Bigg|_s^\infty
\end{aligned}$$

$$\begin{aligned}
&= \frac{1}{2} \log 1 - \frac{1}{2} \log \frac{1 + \frac{a^2}{s^2}}{1 + \frac{b^2}{s^2}} \\
&= -\frac{1}{2} \log \frac{s^2 + a^2}{s^2 + b^2} \\
&= \frac{1}{2} \log \frac{s^2 + b^2}{s^2 + a^2}.
\end{aligned}$$

(5) Let

$$f(t) = e^{-at} - e^{-bt}$$

Now, 
$$\lim_{t \rightarrow 0} \frac{f(t)}{t} = \lim_{t \rightarrow 0} \frac{e^{-at} - e^{-bt}}{t} = \lim_{t \rightarrow 0} \frac{-ae^{-at} + be^{-bt}}{1} \quad (\text{Using L' Hospital Rule})$$

$= b - a$ , which is finite.

Now

$$\begin{aligned}
L\{f(t)\} &= L\{e^{-at} - e^{-bt}\} \\
&= \frac{1}{s+a} - \frac{1}{s+b}
\end{aligned}$$

$$\begin{aligned}
L\{f(t)\} &= L\left\{\frac{e^{-at} - e^{-bt}}{t}\right\} = \int_s^\infty \left(\frac{1}{s+a} - \frac{1}{s+b}\right) ds \\
&= \left[\log(s+a) - \log(s+b)\right]_s^\infty \\
&= \log \frac{s+a}{s+b} \Big|_s^\infty \\
&= \log \frac{1 + \frac{a}{s}}{1 + \frac{b}{s}} \Big|_s^\infty \\
&= \log 1 - \log \frac{1 + \frac{a}{s}}{1 + \frac{b}{s}} \\
&= -\log \frac{s+a}{s+b} \\
&= \log \frac{s+b}{s+a}.
\end{aligned}$$



(6) Let  $f(t) = \sin h at$

$$\begin{aligned} \text{Now, } \lim_{t \rightarrow 0} \frac{f(t)}{t} &= \lim_{t \rightarrow 0} \frac{\sin h at}{t} \\ &= \lim_{t \rightarrow 0} \frac{e^{at} - e^{-at}}{2t} \\ &= \lim_{t \rightarrow 0} \frac{ae^{at} + ae^{-at}}{2} \quad \text{(Using L' Hospital Rule)} \\ &= a, \text{ which is finite.} \end{aligned}$$

$$\text{We have, } L(\sin h at) = \frac{a}{s^2 - a^2}$$

$$\begin{aligned} L\left\{\frac{\sin h at}{t}\right\} &= \int_s^\infty \frac{a}{s^2 - a^2} ds \\ &= \frac{a}{2} \log \left. \frac{s-a}{s+a} \right|_s^\infty \\ &= \frac{a}{2} \left[ \log 1 - \log \left( \frac{s-a}{s+a} \right) \right] \\ &= \frac{a}{2} \left[ -\log \left( \frac{s-a}{s+a} \right) \right] \\ &= \frac{a}{2} \log \frac{s+a}{s-a}. \end{aligned}$$

5. If  $L\{f(t)\} = F(s)$  then prove that  $\int_0^\infty \frac{f(t)}{t} dt = \int_s^\infty F(s) ds$  provided both the integrals exist.

Hence prove that  $\int_0^\infty \frac{\sin t}{t} dt = \frac{\pi}{2}$ .

**Solution.** We have,

$$L\left\{\frac{f(t)}{t}\right\} = \int_s^\infty F(s) ds$$

$$\text{i.e., } \int_0^\infty e^{-st} \left\{\frac{f(t)}{t}\right\} dt = \int_s^\infty F(s) ds$$

Taking the limits on both sides as  $s \rightarrow 0^+$ , we get

$$\int_0^\infty \frac{f(t)}{t} dt = \int_s^\infty F(s) ds$$

This completes the proof of the example.

Let  $f(t) = \sin t$ , then  $F(s) = L(\sin t) = \frac{1}{s^2 + 1}$

$$\begin{aligned} \therefore \int_0^{\infty} \frac{\sin t}{t} dt &= \int_0^{\infty} \frac{1}{s^2 + 1} ds = \tan^{-1} s \Big|_0^{\infty} \\ &= \tan^{-1} \infty - \tan^{-1} 0 \\ &= \frac{\pi}{2}. \end{aligned}$$

### EXERCISE 7.3

Find the Laplace transform of the following functions:

1.  $t \cos^2 t$ .  $\left[ \text{Ans. } \frac{s^4 + 2s^2 + 8}{s^2 (s^2 + 4)^2} \right]$       2.  $t \sin^2 t$ .  $\left[ \text{Ans. } \frac{2(3s^2 + 4)}{s^2 (s^2 + 4)^2} \right]$

3.  $t \sin^3 t$ .  $\left[ \text{Ans. } \frac{24s(s^2 + 5)}{(s^2 + 1)^2 (s^2 + 9)^2} \right]$       4.  $t \cos^3 t$ .  $\left[ \text{Ans. } \frac{1}{4} \left[ \frac{s^2 - 9}{(s^2 + 9)^2} + \frac{3(s^2 - 1)}{(s^2 + 1)^2} \right] \right]$

5.  $t \sin 3t \cos t$ .  $\left[ \text{Ans. } \frac{2s(3s^4 + 48s^2 + 288)}{(s^2 + 16)^2 (s^2 + 4)^2} \right]$

6.  $t^2 \sin at$ .  $\left[ \text{Ans. } \frac{2a(s^2 - a^2)}{(s^2 + a^2)^2} \right]$       7.  $t^2 \cos h at$ .  $\left[ \text{Ans. } \frac{2s(s^2 + 3a^2)}{(s^2 - a^2)^3} \right]$

8.  $te^{-2t} \sin 3t$ .  $\left[ \text{Ans. } \frac{6(s + 2)}{(s^2 + 4s + 13)^2} \right]$       9.  $t e^t \cos 2t$ .  $\left[ \text{Ans. } \frac{s^2 - 2s - 3}{(s^2 - 2s + 5)^2} \right]$

Evaluate the following:

1.  $\int_0^{\infty} e^{-2t} \cdot t \sin 4t dt$ .  $\left[ \text{Ans. } \frac{1}{25} \right]$       2.  $\int_0^{\infty} te^{-3t} \cos 2t dt$ .  $\left[ \text{Ans. } \frac{5}{169} \right]$

3.  $\int_0^{\infty} t^2 e^t \cos t dt$ .  $\left[ \text{Ans. } 1 \right]$       4.  $\int_0^{\infty} t^2 e^{-t} \sin 2t dt$ .  $\left[ \text{Ans. } \frac{-12}{25} \right]$

5.  $\int_0^{\infty} t^3 e^{-t} \cos t dt$ .  $\left[ \text{Ans. } \frac{-3}{2} \right]$       6.  $\int_0^{\infty} t^3 e^{2t} \sin t dt$ .  $\left[ \text{Ans. } \frac{-24}{625} \right]$

Find the Laplace transforms of the following functions:

$$\begin{array}{ll}
 1. \frac{1-e^t}{t} & \left[ \text{Ans. } \log \frac{s-1}{s} \right] \\
 2. \frac{\sin 2t}{t} & \left[ \text{Ans. } \cos^{-1} \frac{s}{2} \right] \\
 3. \frac{e^t \sin t}{t} & \left[ \text{Ans. } \cos^{-1} (s-1) \right] \\
 4. \frac{\sin^2 t}{t} & \left[ \text{Ans. } \frac{1}{4} \log \frac{s^2+4}{s^2} \right] \\
 5. \frac{2 \sin 3t \cos 5t}{t} & \left[ \text{Ans. } \tan^{-1} \frac{s}{2} - \tan^{-1} \frac{s}{8} \right] \\
 6. \frac{\cosh at - \cos ht}{t} & \left[ \text{Ans. } \frac{1}{2} \log \frac{s^2-b^2}{s^2-a^2} \right]
 \end{array}$$

Prove the following:

$$\begin{array}{l}
 1. \int_0^{\infty} \frac{\cos 6t - \cos 4t}{t} dt = \log \frac{3}{2}. \\
 2. \int_0^{\infty} \frac{e^{-t} - e^{-3t}}{t} dt = \log 3. \\
 3. \int_0^{\infty} \frac{e^{-t} \sin t}{t} dt = \frac{\pi}{4}.
 \end{array}$$

## 7.4 LAPLACE TRANSFORMS OF PERIODIC FUNCTIONS

A function  $f(t)$  is said to be periodic function with period  $\alpha > 0$ , if  $f(t + \alpha) = f(t)$ .

**Theorem:** If  $f(t)$  is a periodic function of period  $\alpha > 0$ , then

$$L\{f(t)\} = \frac{1}{1-e^{-s\alpha}} \int_0^{\alpha} e^{-st} f(t) dt \quad \dots(1)$$

**Proof:** We have, 
$$L\{f(t)\} = \int_0^{\infty} e^{-st} f(t) dt$$

$$= \int_0^{\alpha} e^{-st} f(t) dt + \int_{\alpha}^{2\alpha} e^{-st} f(t) dt + \int_{2\alpha}^{3\alpha} e^{-st} f(t) dt + \dots \quad \dots(2)$$

Substitute,  $t = u + \alpha$  in the second integral

Then

$$dt = du$$

When

$$t = \alpha, u = 0, \text{ and } t = 2\alpha, u = \alpha.$$

Hence 
$$\int_{\alpha}^{2\alpha} e^{-st} f(t) dt = \int_0^{\alpha} e^{-s(u+\alpha)} f(u+\alpha) du$$

Since

$$f(u+\alpha) = f(u)$$

$$\begin{aligned}
 &= e^{-s\alpha} \int_0^{\alpha} e^{-su} f(u) du \\
 &= e^{-s\alpha} \int_0^{\alpha} e^{-st} f(t) dt \quad \text{(replacing } u \text{ by } t)
 \end{aligned}$$

Similarly by substituting  $t = u + 2\alpha$  in the 3<sup>rd</sup> integral, we get,

$$\int_{2\alpha}^{3\alpha} e^{-st} f(t) dt = e^{-2s\alpha} \int_0^{\alpha} e^{-st} f(t) dt$$

and so on.

$\therefore$  Equation (2) reduces to

$$\begin{aligned}
 L\{f(t)\} &= \int_0^{\alpha} e^{-st} f(t) dt + e^{-s\alpha} \int_0^{\alpha} e^{-st} f(t) dt + e^{-2s\alpha} \int_0^{\alpha} e^{-st} f(t) dt + \dots \\
 &= \left[ 1 + e^{-s\alpha} + (e^{-s\alpha})^2 + \dots \right] \int_0^{\alpha} e^{-st} f(t) dt \\
 &= \frac{1}{1 - e^{-s\alpha}} \int_0^{\alpha} e^{-st} f(t) dt
 \end{aligned}$$

Since,  $1 + r + r^2 + \dots$  to  $\infty = \frac{1}{1-r}$  and

$$|r| = |e^{-s\alpha}| < 1.$$

Thus, 
$$L\{f(t)\} = \frac{1}{1 - e^{-s\alpha}} \int_0^{\alpha} e^{-st} f(t) dt$$

This completes the proof of the theorem.

### WORKED OUT EXAMPLES

1. If  $f(x) = \begin{cases} 3t, & 0 < t < 2 \\ 6, & 2 < t < 4 \end{cases}$  and  $f(t) = f(t + 4)$ , find  $L\{f(t)\}$ .

**Solution.** Since  $f(t)$  is a periodic function with period  $\alpha = 4$  from (1), we get

$$L\{f(t)\} = \frac{1}{1 - e^{-4s}} \int_0^4 e^{-st} f(t) dt \quad \dots(1)$$

Now, 
$$\begin{aligned}
 \int_0^4 e^{-st} f(t) dt &= \int_0^2 e^{-st} \cdot 3t dt + \int_2^4 e^{-st} \cdot 6 dt \\
 &= 3 \left[ t \cdot \frac{e^{-st}}{-s} - 1 \cdot \frac{e^{-st}}{(-s)^2} \right]_0^2 + \left[ 6 \frac{e^{-st}}{-s} \right]_2^4
 \end{aligned}$$

$$\begin{aligned}
&= 3 \left[ -2 \frac{e^{-2s}}{s} - \frac{e^{-2s}}{s^2} \right] - 3 \left[ 0 - \frac{1}{s^2} \right] - \frac{6}{s} (e^{-4s} - e^{-2s}) \\
&= \frac{3}{s^2} - \frac{3e^{-2s}}{s^2} - \frac{6e^{-4s}}{s} \\
&= \frac{3}{s^2} (1 - e^{-2s} - 2s e^{-4s})
\end{aligned}$$

Therefore from (1), we get

$$L \{ f(t) \} = \frac{3(1 - e^{-2s} - 2s e^{-4s})}{s^2 (1 - e^{-4s})}.$$

2. If A periodic function  $f(t)$  of period  $2a$  is defined by

$$f(t) = \begin{cases} a & \text{for } 0 \leq t < a \\ -a & \text{for } a \leq t \leq 2a \end{cases}$$

Show that  $L \{ f(t) \} = \frac{a}{s} \tan h \left( \frac{as}{2} \right)$ .

**Solution.** Since  $f(t)$  is a periodic function with period  $2a$ , we have from Eqn. (1),

$$L \{ f(t) \} = \frac{1}{1 - e^{-2as}} \int_0^{2a} e^{-st} f(t) dt \quad \dots(1)$$

$$\begin{aligned}
\text{Now} \quad \int_0^{2a} e^{-st} f(t) dt &= \int_0^a e^{-st} \cdot a dt + \int_a^{2a} e^{-st} (-a) dt \\
&= \left[ \frac{ae^{-st}}{-s} \right]_0^a + \left[ \frac{-ae^{-st}}{-s} \right]_a^{2a} \\
&= \frac{-a}{s} \{ e^{-as} - 1 \} + \frac{a}{s} [e^{-2as} - e^{-as}] \\
&= \frac{a}{s} \{ 1 - 2e^{-as} + e^{-2as} \} \\
&= \frac{a}{s} (1 - e^{-as})^2
\end{aligned}$$

Therefore from (i), we obtain,

$$\begin{aligned}
L \{ f(t) \} &= \frac{a}{s} \cdot \frac{(1 - e^{-as})^2}{(1 - e^{-2as})} \\
&= \frac{a}{s} \frac{(1 - e^{-as})^2}{(1 - e^{-as})(1 + e^{-as})}
\end{aligned}$$

$$\begin{aligned}
&= \frac{a}{s} \cdot \frac{1 - e^{-as}}{1 + e^{-as}} \\
&= \frac{a}{s} \left\{ \begin{array}{l} \frac{as}{e^{\frac{as}{2}} - e^{-\frac{as}{2}}} \\ \frac{as}{e^{\frac{as}{2}} + e^{-\frac{as}{2}}} \end{array} \right\}
\end{aligned}$$

Multiplying numerator and denominator by  $e^{\frac{as}{2}}$

$$= \frac{a}{s} \tanh \left( \frac{as}{2} \right).$$

3. If  $f(t) = t^2$ ,  $0 < t < 2$  and  $f(t+2) = f(t)$  for  $t > 2$ , find  $L\{f(t)\}$ .

**Solution.** Here  $f(t)$  is a periodic function with period 2. Therefore from eqn. (1), we have

$$L\{f(t)\} = \frac{1}{1 - e^{-2s}} \int_0^2 e^{-st} \cdot t^2 dt \quad \dots(1)$$

Consider, 
$$\int_0^2 e^{-st} t^2 dt = \left[ t^2 \frac{e^{-st}}{-s} - 2t \frac{e^{-st}}{(-s)^2} + 2 \frac{e^{-st}}{(-s)^3} \right]_0^2$$

On Integrating by parts,

$$\begin{aligned}
&= \left\{ \frac{-4}{s} e^{-2s} - \frac{4e^{-2s}}{s^2} - \frac{2}{s^3} e^{-2s} \right\} - \left\{ -\frac{2}{s^3} \right\} \\
&= \frac{2}{s^3} - \frac{e^{-2s}}{s^3} (4s^2 + 4s + 2) \\
&= \frac{2}{s^3} [1 - (2s^2 + 2s + 1)e^{-2s}]
\end{aligned}$$

Therefore from (i), we get

$$L\{f(t)\} = \frac{2}{s^3(1 - e^{-2s})} [1 - (2s^2 + 2s + 1)e^{-2s}]$$

4. A periodic function of period  $\frac{2\pi}{\omega}$  is defined by

$$f(t) = \begin{cases} E \sin \omega t, & 0 \leq t < \frac{\pi}{\omega} \\ 0, & \frac{\pi}{\omega} \leq t < \frac{2\pi}{\omega} \end{cases}$$

where  $E$  and  $\omega$  are constants.

Show that, 
$$L\{f(t)\} = \frac{E\omega}{(s^2 + \omega^2) \left( 1 - e^{-\frac{\pi s}{\omega}} \right)}$$

**Solution.** We have a periodic function  $f(t)$

$$L\{f(t)\} = \frac{1}{1 - e^{-s\alpha}} \int_0^{\alpha} e^{-st} f(t) dt$$

Hence

$$\begin{aligned} \alpha &= \frac{2\pi}{\omega} \\ &= \frac{1}{1 - e^{-\frac{2\pi s}{\omega}}} \int_0^{\frac{2\pi}{\omega}} e^{-st} f(t) dt \\ &= \frac{1}{1 - e^{-\frac{2\pi s}{\omega}}} \left[ \int_0^{\frac{2\pi}{\omega}} e^{-st} E \sin \omega t dt + \int_{\frac{\pi}{\omega}}^{\frac{2\pi}{\omega}} e^{-st} \cdot 0 dt \right] \\ &= \frac{1}{1 - e^{-\frac{2\pi s}{\omega}}} \int_0^{\frac{\pi}{\omega}} e^{-st} E \sin \omega t dt \quad \dots(1) \end{aligned}$$

Consider

$$\begin{aligned} &= \int_0^{\frac{\pi}{\omega}} e^{-st} E \sin \omega t dt \\ &= E \int_0^{\frac{\pi}{\omega}} e^{-st} \sin \omega t dt \\ &= E \left[ \frac{e^{-st}}{(-s)^2 + \omega^2} (-s \sin \omega t - \omega \cos \omega t) \right]_0^{\frac{\pi}{\omega}} \\ &= \frac{-E}{s^2 + \omega^2} \left[ e^{-s\pi/\omega} (+s \sin \pi + \omega \cos \pi) - e^0 (s \sin 0 + \omega \cos 0) \right] \\ &= \frac{-E}{s^2 + \omega^2} \left[ e^{-\frac{s\pi}{\omega}} (s \sin \pi + \omega \cos \pi) - e^0 (s \sin 0 + \omega \cos 0) \right] \\ &= \frac{-E}{s^2 + \omega^2} \left[ e^{-\frac{s\pi}{\omega}} (0 + \omega(-1)) - \omega \right] \\ &= \frac{-E}{s^2 + \omega^2} \left[ -\omega e^{-\frac{s\pi}{\omega}} - \omega \right] \\ &= \frac{E\omega}{s^2 + \omega^2} \left( 1 + e^{-\frac{s\pi}{\omega}} \right) \end{aligned}$$

Hence from Eqn. (1), we get

$$= \frac{1}{1 - e^{-\frac{2\pi s}{\omega}}} \cdot \frac{E\omega}{s^2 + \omega^2} \left( 1 + e^{-\frac{s\pi}{\omega}} \right)$$

$$L\{f(t)\} = \frac{E\omega \left( 1 + e^{-\frac{s\pi}{\omega}} \right)}{(s^2 + \omega^2) \left( 1 - e^{-\frac{s\pi}{\omega}} \right) \left( 1 + e^{-\frac{s\pi}{\omega}} \right)}$$

$$L\{f(t)\} = \frac{E\omega}{(s^2 + \omega^2) \left( 1 - e^{-\frac{s\pi}{\omega}} \right)} \quad \text{Hence proved.}$$

### EXERCISE 7.3

Find the Laplace transforms of the following periodic functions:

1.  $f(t) = t, 0 < t < 2$  and  $f(t+2) = f(t)$ . [ Ans.  $\frac{1}{s^2} - \frac{2e^{-2s}}{s(1-e^{-2s})}$  ]
2.  $f(t) = t^2, 0 < t < 3$  and  $f(t+3) = f(t)$ . [ Ans.  $\frac{1}{s^3(1-e^{-3s})} [2 - (9s^2 + 6s + 2)e^{-3s}]$  ]
3.  $f(t) = a - t, 0 < t < a$  and  $f(t+a) = f(t)$ . [ Ans.  $\frac{as - 1 + e^{-as}}{s^2(1-e^{-as})}$  ]
4.  $f(t) = e^{-t}, 0 < t < 1$  and  $f(t+1) = f(t)$ . [ Ans.  $\frac{1 - e^{-(s+1)}}{(s+1)(1-e^{-s})}$  ]
5.  $f(t) = \begin{cases} 1, & 0 < t \leq 1 \\ -1, & 1 < t \leq 2 \end{cases}$  and  $f(t+2) = f(t)$ . [ Ans.  $\frac{1}{s} \tanh h\left(\frac{s}{2}\right)$  ]
6.  $f(t) = \begin{cases} 1, & 0 < t \leq 1 \\ 0, & 1 \leq t < 2 \end{cases}$  and  $f(t+2a) = f(t)$ . [ Ans.  $\frac{1}{s(1+e^{-s})}$  ]
7.  $f(t) = \begin{cases} t, & 0 \leq t < a \\ 2a - t, & a < t \leq 2a \end{cases}$  and  $f(t+2) = f(t)$ . [ Ans.  $\frac{1}{s^2} \tanh h\left(\frac{as}{2}\right)$  ]



$$8. f(t) = \begin{cases} t, & 0 < t < 1 \\ 1, & 1 \leq t < 2 \end{cases} \text{ and } f(t+2) = f(t).$$

$$\left[ \text{Ans. } \frac{1 - e^{-s} - s e^{-2s}}{s^2 (1 - e^{-2s})} \right]$$

$$9. f(t) = \begin{cases} t, & 0 < t < 1 \\ 0, & 1 < t < 2 \end{cases} \text{ and } f(t+2) = f(t).$$

$$\left[ \text{Ans. } \frac{1 - (s+1)e^{-s}}{s^2 (1 - e^{-2s})} \right]$$

## 7.5

## LAPLACE TRANSFORMS OF UNIT STEP FUNCTION AND UNIT IMPULSE FUNCTION

## Unit Step Function (Heaviside function)

The unit step function or Heaviside function  $u(t-a)$  is defined as follows

$$u(t-a) = \begin{cases} 0, & \text{when } t \leq a \\ 1, & \text{when } t > a \end{cases} \quad \dots(1)$$

where  $a \geq 0$

The graph of this function is as shown in the below.

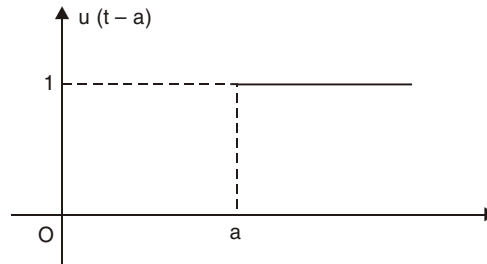

Fig. 7.1

where  $a$  is the +ve constant.

## 7.5.1 Properties Associated with the Unit Step Function

$$(i) L u(t-a) = \frac{e^{-as}}{s}$$

$$(ii) L \{ f(t-a) u(t-a) \} = e^{-as} F(s) = e^{-as} L \{ f(t) \}.$$

**Proof:** (i) Using the definition of Laplace transform, we have

$$\begin{aligned} L \{ u(t-a) \} &= \int_0^{\infty} e^{-st} u(t-a) dt \\ &= \int_0^a e^{-st} u(t-a) dt + \int_a^{\infty} e^{-st} u(t-a) dt \\ &= \int_0^a e^{-st} \cdot 0 dt + \int_a^{\infty} e^{-st} \cdot 1 dt \end{aligned}$$

$$\begin{aligned}
&= 0 + \frac{e^{-st}}{-s} \Big|_a^\infty \\
&= \frac{-1}{s} [e^{-\infty} - e^{-as}] = \frac{e^{-as}}{s}
\end{aligned}$$

Thus,  $L\{u(t-a)\} = \frac{e^{-as}}{s}$

**(ii) Heaviside Shifting Theorem:**

If  $L\{f(t)\} = F(s)$  then

$$L\{f(t-a)u(t-a)\} = e^{-as}F(s) = e^{-as}L\{f(t)\}$$

where  $u(t-a)$  is the unit step function.

**Proof:** By definition, we have

$$\begin{aligned}
L\{f(t-a)u(t-a)\} &= \int_0^\infty e^{-st} f(t-a)u(t-a) dt \\
&= \int_0^a e^{-st} f(t-a)u(t-a) dt + \int_a^\infty e^{-st} f(t-a)u(t-a) dt \\
&= \int_0^a e^{-st} f(t-a)(0) dt + \int_a^\infty e^{-st} f(t-a) \cdot 1 dt \\
&= \int_a^\infty e^{-st} f(t-a) dt
\end{aligned}$$

Substitute  $t-a = x$  so that  $dt = dx$ ,

When  $t = a, \quad x = 0$  and  
 $t = \infty, \quad x = \infty, \quad t = a + x$

Hence,

$$\begin{aligned}
L\{f(t-a)u(t-a)\} &= \int_0^\infty e^{-s(a+x)} f(x) dx \\
&= e^{-sa} \int_0^\infty e^{-sx} f(x) dx \\
&= e^{-as} \int_0^\infty e^{-st} f(t) dt \quad \text{change } x \text{ to } t \\
&= e^{-as} L\{f(t)\} \\
&= e^{-as} F(s). \quad \text{Hence proved.}
\end{aligned}$$

## 7.5.2 Laplace Transform of the Unit Impulse Function

### Unit Impulse Function

**Definition:** The unit impulse function denoted by  $\delta(t-a)$  is defined as follows

$$\delta(t-a) = \lim_{\epsilon \rightarrow 0} \delta_{\epsilon}(t-a), \quad a \geq 0 \quad \dots(1)$$

Where

$$\delta_{\epsilon}(t-a) = \begin{cases} 0, & \text{if } t < a \\ \frac{1}{\epsilon}, & \text{if } a < t < a + \epsilon \\ 0, & \text{if } t > a + \epsilon \end{cases} \quad \dots(2)$$

The graph of the function  $\delta_{\epsilon}(t-a)$  is as shown below:

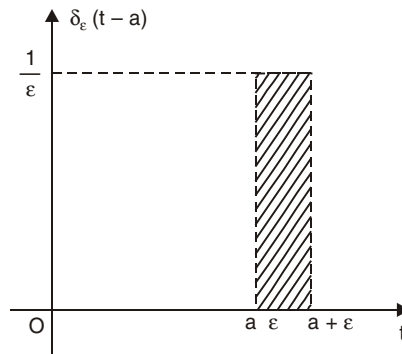

Fig. 7.2

Laplace transform of the unit impulse function

Consider

$$\begin{aligned} L\{\delta_{\epsilon}(t-a)\} &= \int_0^{\infty} e^{-st} \delta_{\epsilon}(t-a) dt \\ &= \int_0^a e^{-st} (0) dt + \int_a^{a+\epsilon} e^{-st} \frac{1}{\epsilon} dt + \int_{a+\epsilon}^{\infty} e^{-st} (0) dt \\ &= \frac{1}{\epsilon} \int_a^{a+\epsilon} e^{-st} dt = \frac{1}{\epsilon} \left[ \frac{e^{-st}}{-s} \right]_a^{a+\epsilon} \\ &= -\frac{1}{\epsilon s} \left[ e^{-s(a+\epsilon)} - e^{-as} \right] \\ &= e^{-as} \left[ \frac{1 - e^{-\epsilon s}}{\epsilon s} \right] \end{aligned}$$

Taking the limits on both sides as  $\epsilon \rightarrow 0$ , we get,

$$\lim_{\epsilon \rightarrow 0} L\{\delta_{\epsilon}(t-a)\} = e^{-as} \lim_{\epsilon \rightarrow 0} \left[ \frac{1 - e^{-\epsilon s}}{\epsilon s} \right]$$

*i.e.*,  $L\{\delta(t-a)\} = e^{-as}$  (Using L' Hospital Rule)

If  $a = 0$  then  $L\{\delta(t)\} = 1$



$$\begin{aligned} \text{(5) Now} \quad \sin t + \cos t &= \cos\left(\frac{\pi}{2} - t\right) + \sin\left(\frac{\pi}{2} - t\right) \\ &= \cos\left(t - \frac{\pi}{2}\right) - \sin\left(t - \frac{\pi}{2}\right) \end{aligned}$$

$$\therefore L\left\{(\sin t + \cos t)u\left(t - \frac{\pi}{2}\right)\right\} = L\left\{\left[\cos\left(t - \frac{\pi}{2}\right) - \sin\left(t - \frac{\pi}{2}\right)\right]u\left(t - \frac{\pi}{2}\right)\right\}$$

Replacing  $t - \frac{\pi}{2}$  by  $t$ .

$$e^{-\left(\frac{\pi}{2}\right)s} L\{\cos t - \sin t\}$$

Using Heaviside function

$$\begin{aligned} &= e^{\left(\frac{-\pi}{2}\right)s} \{L(\cos t) - L(\sin t)\} \\ &= e^{\left(\frac{-\pi}{2}\right)s} \cdot \left\{\frac{s}{s^2 + 1} - \frac{1}{s^2 + 1}\right\} \\ &= \frac{e^{-\left(\frac{\pi}{2}\right)s} \cdot (s - 1)}{s^2 + 1}. \end{aligned}$$

2. Express the following functions in terms of the Heaviside's unit step function and hence find their Laplace transforms.

$$(1) f(t) = \begin{cases} t^2, & 0 < t < 2 \\ 4t, & t > 2 \end{cases} \qquad (2) f(t) = \begin{cases} 3t, & 0 < t < 4 \\ 5, & t > 4 \end{cases}$$

$$(3) f(t) = \begin{cases} e^{-t}, & 0 < t < 3 \\ 0, & t > 3 \end{cases}.$$

**Solution.** (1) Given function  $f(t)$  can be expressed in terms of the Heaviside's unit step function as

$$f(t) = t^2 + (4t - t^2)u(t - 2)$$

Taking Laplace transform on both sides, we get,

$$\begin{aligned} L\{f(t)\} &= L(t^2) + L\{(4t - t^2)u(t - 2)\} \\ &= \frac{2}{s^3} - L\{(t^2 - 4t)u(t - 2)\} \\ &= \frac{2}{s^3} - L\{[(t - 2)^2 - 4]u(t - 2)\} \\ &= \frac{2}{s^3} - e^{-2s} - L\{t^2 - 4\} \end{aligned}$$

(Using Heaviside shifting theorem.)

$$\begin{aligned}
 &= \frac{2}{s^3} - e^{-2s} - L\{(t^2) - 4L(1)\} \\
 &= \frac{2}{s^3} - e^{-2s} \left\{ \frac{2}{s^3} - \frac{4}{s} \right\}.
 \end{aligned}$$

(2) In terms of the Heaviside step function

We have

$$f(t) = 3t + (5 - 3t)u(t - 4)$$

$$\begin{aligned}
 \therefore L[f(t)] &= 3L(t) + L\{(5 - 3t)u(t - 4)\} \\
 &= \frac{3}{s^2} + L\{[-3(t - 4) - 7]u(t - 4)\} \\
 &= \frac{3}{s^2} + e^{-4s} L\{(-3t - 7)\} \\
 &= \frac{3}{s^2} + e^{-4s} \left\{ \frac{-3}{s^2} - \frac{7}{s} \right\} \\
 &= \frac{3}{s^2} - \left\{ \frac{3}{s^2} + \frac{7}{s} \right\} e^{-4s}.
 \end{aligned}$$

(3) Now,

$$f(t) = e^{-t} + [0 - e^{-t}]u(t - 3)$$

$$\begin{aligned}
 \therefore &= e^{-t} - e^{-t}u(t - 3) \\
 &= e^{-t} - e^{-(t-3)}u(t - 3)e^{-3} \\
 L\{f(t)\} &= L(e^{-t}) - e^{-3}L\{e^{-(t-3)}u(t - 3)\} \\
 &= \frac{1}{s+1} - e^{-3}e^{-3s}L(e^{-t}) \\
 &= \frac{1}{s+1} - e^{-3(s+1)} \cdot \frac{1}{s+1} \\
 &= \frac{1 - e^{-3(s+1)}}{s+1}.
 \end{aligned}$$

3. Express  $f(t)$  in terms of the Heavisides unit step function and find its Laplace transform:

$$f(t) = \begin{cases} t^2, & 0 < t < 2 \\ 4t, & 2 < t < 4 \\ 8, & t > 4 \end{cases}$$

**Solution.** We get

$$f(t) = t^2 + (4t - t^2)u(t - 2) + (8 - 4t)u(t - 4)$$

$$f(t) = t^2 + [4 - (t - 2)^2]u(t - 2) + [-4(t - 4) - 8]u(t - 4)$$

Taking Laplace transform on both sides, we get,

$$\begin{aligned} L\{f(t)\} &= L(t^2) + L\{[4-(t-2)^2]u(t-2)\} + L\{[-4(t-4)-8]u(t-4)\} \\ &= \frac{2}{s^3} + e^{-2s} L(4-t^2) + e^{-4s} L(-4t-8) \end{aligned}$$

Using Heaviside shift theorem.

$$\begin{aligned} &= \frac{2}{s^3} + e^{-2s} \left( \frac{4}{s} - \frac{2}{s^3} \right) + e^{-4s} \left( \frac{-4}{s^2} - \frac{8}{s} \right) \\ &= \frac{2}{s^3} + 2e^{-2s} \left( \frac{2}{s} - \frac{1}{s^3} \right) - 4e^{-4s} \left( \frac{1}{s^2} + \frac{2}{s} \right). \end{aligned}$$

4. Find  $L[2\delta(t-1) + 3\delta(t-2) + 4\delta(t+3)]$ .

**Solution.** We have

$$\begin{aligned} &= 2L\delta(t-1) + 3L\delta(t-2) + 4L\delta(t+3) \\ &= 2e^{-s} + 3e^{-2s} + 4e^{3s}. \end{aligned} \quad \text{Since } L\delta(t-a) = e^{-as}$$

5. Find  $L[\cosh 3t \delta(t-2)]$ .

**Solution**

$$\begin{aligned} \cosh 3t \delta(t-2) &= \frac{1}{2} \{e^{3t} + e^{-3t}\} \delta(t-2) \\ L[\cosh 3t \delta(t-2)] &= \frac{1}{2} \{L[e^{3t} \delta(t-2)] + L[e^{-3t} \delta(t-2)]\} \\ &= \text{shifting} \quad \begin{array}{l} s-3 \rightarrow s \\ s+3 \rightarrow s \end{array} \\ &= \frac{1}{2} \{L[\delta(t-2)]_{s \rightarrow s-3} + L[\delta(t-2)]_{s \rightarrow s+3}\} \\ &= \frac{1}{2} \left\{ (e^{-2s})_{s \rightarrow s-3} + (e^{-2s})_{s \rightarrow s+3} \right\} \\ &= \frac{1}{2} \{e^{-2(s-3)} + e^{-2(s+3)}\} \\ &= \frac{e^{-2s}}{2} \{e^6 + e^{-6}\} \\ L[\cosh 3t \delta(t-2)] &= \cosh 6 e^{-2s} \end{aligned}$$

## EXERCISE 7.4

Find the Laplace transforms of the following functions:

$$1. (2t + 3)u(t-1). \quad \left[ \text{Ans. } e^{-s} \left( \frac{2}{s^2} + \frac{5}{s} \right) \right]$$

$$2. t^2 u(t-2). \quad \left[ \text{Ans. } e^{-2s} \left( \frac{2}{s^3} + \frac{4}{s^2} + \frac{4}{s} \right) \right]$$

$$3. (t^2 + 2t - 1)u(t-3). \quad \left[ \text{Ans. } e^{-2s} \left( \frac{2}{s^3} + \frac{8}{s^2} + \frac{14}{s} \right) \right]$$

$$4. e^{3t} u(t-1). \quad \left[ \text{Ans. } \frac{e^{-(s-3)}}{s-3} \right]$$

$$5. (1 - e^{2t})u(t-2). \quad \left[ \text{Ans. } \frac{e^{-2s}}{s(s+1)} \right]$$

Express the following functions in terms of the Heaviside's unit step function and hence find their Laplace transformation.

$$1. f(t) = \begin{cases} 2, & 0 < t < 1 \\ 3, & t > 1 \end{cases}. \quad \left[ \text{Ans. } \frac{2 + e^{-s}}{s} \right]$$

$$2. f(t) = \begin{cases} 3, & 0 < t < 2 \\ t, & t > 2 \end{cases}. \quad \left[ \text{Ans. } \frac{3}{s} + e^{-2s} \left( \frac{1}{s^2} - \frac{1}{s} \right) \right]$$

$$3. f(t) = \begin{cases} 4, & 0 < t < 3 \\ t^2, & t > 3 \end{cases}. \quad \left[ \text{Ans. } \frac{4}{s} + e^{-3s} \left( \frac{2}{s^3} + \frac{6}{s^2} + \frac{5}{s} \right) \right]$$

$$4. f(t) = \begin{cases} 4t, & 0 < t < 2 \\ t^2, & t > 2 \end{cases}. \quad \left[ \text{Ans. } \frac{4}{s^2} + e^{-2s} \left( \frac{2}{s^3} - \frac{4}{s} \right) \right]$$

$$5. f(t) = \begin{cases} e^{2t}, & 0 < t < 1 \\ 2, & t > 1 \end{cases}. \quad \left[ \text{Ans. } \frac{1}{s-2} + e^{-s} \left( \frac{2}{s} - \frac{e^2}{s-1} \right) \right]$$

$$6. f(t) = \begin{cases} \sin t, & 0 < t < \frac{\pi}{2} \\ \cos t, & t > \frac{\pi}{2} \end{cases}. \quad \left[ \text{Ans. } \frac{1}{s^2+1} - e^{\left(\frac{-\pi}{2}\right)s} \left\{ \frac{1+s}{s^2+1} \right\} \right]$$

$$7. f(t) = \begin{cases} 1, & 0 < t < 1 \\ t, & 1 < t < 3 \\ t^2, & t > 3 \end{cases}. \quad \left[ \text{Ans. } \frac{1}{s} + \frac{e^{-s}}{s^2} + e^{-3s} \left( \frac{2}{s^3} + \frac{5}{s^2} + \frac{6}{s} \right) \right]$$



$$8. f(t) = \begin{cases} \cos t, & 0 < t < \pi \\ \cos 2t, & \pi < t < 2\pi. \\ \cos 3t, & t > 2\pi \end{cases} \quad \left[ \text{Ans. } \frac{s}{s^2 + 1} + e^{-\pi s} \left\{ \frac{s}{s^2 + 4} + \frac{s}{s^2 + 1} \right\} + \frac{5se^{-2\pi s}}{(s^2 + 4)(s^2 + 9)} \right]$$

$$9. f(t) = \begin{cases} \cos t, & 0 < t \leq \pi \\ 1, & \pi < t \leq 2\pi. \\ \sin t, & t > 2\pi \end{cases} \quad \left[ \text{Ans. } \frac{s}{s^2 + 1} + \left\{ \frac{1}{s} + \frac{s}{s^2 + 1} \right\} e^{-\pi s} - \left\{ \frac{1}{s} - \frac{1}{s^2 + 1} \right\} e^{-2\pi s} \right]$$

$$10. f(t) = \begin{cases} t^2, & 0 < t < 2 \\ 4, & 2 < t < 4. \\ 0, & t > 4 \end{cases} \quad \left[ \text{Ans. } \frac{2}{s^3} - \left\{ \frac{2}{s^3} + \frac{4}{s^2} \right\} e^{-2s} - \frac{4}{s} e^{-4s} \right]$$

### ADDITIONAL PROBLEMS (From Previous Years VTU Exams.)

1. Find the Laplace transforms of:

$$2^t + \frac{\cos 2t - \cos 3t}{t} + t \sin t$$

**Solution.** The given function be denoted by  $f(t)$  and let

$$f(t) = F(t) + G(t) + H(t)$$

where  $F(t) = 2^t$ ,  $G(t) = \frac{\cos 2t - \cos 3t}{t}$ ,

$$H(t) = t \sin t$$

$$\therefore L[f(t)] = L[F(t)] + L[G(t)] + L[H(t)] \quad \dots(1)$$

Now  $L[F(t)] = L[2^t] = L[e^{\log 2 \cdot t}] = \frac{1}{s - \log 2}$

$$\begin{aligned} L[G(t)] &= L\left[\frac{\cos 2t - \cos 3t}{t}\right] \\ &= \int_s^\infty L(\cos 2t - \cos 3t) ds \\ &= \int_s^\infty \left(\frac{s}{s^2 + 4} - \frac{s}{s^2 + 9}\right) ds \\ &= \left[\frac{1}{2} \log(s^2 + 4) - \frac{1}{2} \log(s^2 + 9)\right]_s^\infty \\ &= \left[\log \sqrt{\frac{s^2 + 4}{s^2 + 9}}\right]_s^\infty \end{aligned}$$

$$= \left[ \log \sqrt{\frac{1+4/s^2}{1+9/s^2}} \right]_{s=\infty} - \log \sqrt{\frac{s^2+4}{s^2+9}}$$

$$= \log 1 - \log \sqrt{\frac{s^2+9}{s^2+4}}$$

$$L[G(t)] = \log \sqrt{\frac{s^2+9}{s^2+4}}$$

Further  $H(t) = t \sin t$

$$L[H(t)] = \frac{-d}{dt} L(\sin t) = \frac{-d}{ds} \left[ \frac{1}{s^2+1} \right]$$

Hence  $L[H(t)] = \frac{2s}{(s^2+1)^2}$

Thus the required  $L f(t)$  is given by

$$= \frac{1}{s - \log 2} + \log \sqrt{\frac{s^2+9}{s^2+4}} + \frac{2s}{(s^2+1)^2}$$

2. Find the Laplace transforms of  $t^2 e^{-3t} \sin 2t$ .

**Solution.** We shall first find  $L(t^2 \sin 2t)$

we have  $L[t^2 (\sin 2t)] = (-1)^2 \frac{d^2}{ds^2} L(\sin 2t)$

$$L(t^2 \sin 2t) = \frac{d}{ds} \frac{d}{ds} \left[ \frac{2}{s^2+4} \right]$$

$$= \frac{d}{ds} \left[ \frac{-4s}{(s^2+4)^2} \right]$$

$$= \frac{(s^2+4)^2(-4) + 4s \cdot 2(s^2+4) \cdot 2s}{(s^2+4)^4}$$

$$L(t^2 \sin 2t) = \frac{4(3s^2-4)}{(s^2+4)^3}$$

Thus  $L(e^{-3t} t^2 \sin 2t) = \frac{4[3(s+3)^2-4]}{[(s+3)^2+4]^3}$

3. (i) Evaluate:  $L\{t(\sin^3 t - \cos^3 t)\}$

**Solution**

$$\sin^3 t - \cos^3 t = \frac{1}{4} (3 \sin t - \sin 3t) - \frac{1}{4} (3 \cos t + \cos 3t)$$

$$L(\sin^3 t - \cos^3 t) = \frac{1}{4} \left\{ \frac{3}{s^2+1} - \frac{3}{s^2+9} \right\} - \frac{1}{4} \left\{ \frac{3s}{s^2+1} + \frac{s}{s^2+9} \right\}$$

Using the property:  $L[tf(t)] = \frac{-d}{ds}[f(s)]$ , we have

$$\begin{aligned} L[t(\sin^3 t - \cos^3 t)] &= \frac{-3}{4} \left[ \frac{-2s}{(s^2+1)^2} + \frac{2s}{(s^2+9)^2} \right] + \frac{1}{4} \left[ \frac{3(s^2+1) - 2s^2}{(s^2+1)^2} + \frac{s^2+9-2s^2}{(s^2+9)^2} \right] \\ &= \frac{3s}{2} \left[ \frac{1}{(s^2+1)^2} - \frac{1}{(s^2+9)^2} \right] + \frac{1}{4} \left[ 3 \cdot \frac{1-s^2}{(s^2+1)^2} + \frac{9-s^2}{(s^2+9)^2} \right] \end{aligned}$$

(ii) Using Laplace transforms:

Evaluate  $\int_0^{\infty} e^{-t} t \sin^2 3t dt$ .

**Solution.** We shall first find  $L(t \sin^2 3t)$

$$\sin^2 3t = \frac{1}{2} (1 - \cos 6t)$$

$$L(\sin^2 3t) = \frac{1}{2} \left[ \frac{1}{s} - \frac{s}{s^2+36} \right]$$

$$\begin{aligned} L(t \sin^2 3t) &= \frac{1}{2} \cdot \frac{-d}{ds} \left[ \frac{1}{s} - \frac{s}{s^2+36} \right] \\ &= \frac{-1}{2} \left[ \frac{-1}{s^2} - \frac{(s^2+36) - 2s^2}{(s^2+36)^2} \right] \end{aligned}$$

$$\therefore L(t \sin^2 3t) = \frac{1}{2} \left[ \frac{1}{s^2} + \frac{36-s^2}{(s^2+36)^2} \right]$$

Using the basic definition in LHS, we have

$$\int_0^{\infty} e^{-st} t \sin^2 3t dt = \frac{1}{2} \left[ \frac{1}{s^2} + \frac{36-s^2}{(s^2+36)^2} \right]$$

Thus by putting  $s = 1$ , we get

$$\int_0^{\infty} e^{-t} t \sin^2 3t \, dt = \frac{1}{2} \left[ 1 + \frac{35}{37^2} \right] = \frac{702}{1369}$$

4. Find the Laplace transform of:

(i)  $e^{2t} \cos^2 t$       (ii)  $\frac{1 - \cos 3t}{t}$

**Solution.** (i) Let  $f(t) = e^{2t} \cos^2 t = e^{2t} \cdot \frac{1}{2} (1 + \cos 2t)$

$$\begin{aligned} L[f(t)] &= \frac{1}{2} [L(e^{2t}) + L(e^{2t} \cos 2t)] \\ &= \frac{1}{2} \left[ \frac{1}{s-2} + \{L(\cos 2t)\}_{s \rightarrow s-2} \right] \\ &= \frac{1}{2} \left[ \frac{1}{s-2} + \left\{ \frac{s}{s^2+4} \right\}_{s \rightarrow s-2} \right] \\ &= \frac{1}{2} \left[ \frac{1}{s-2} + \frac{s-2}{s^2-4s+8} \right] \end{aligned}$$

Thus  $L(e^{2t} \cos^2 t) = \frac{1}{2} \left[ \frac{1}{s-2} + \frac{s-2}{s^2-4s+8} \right]$

(ii) Let  $f(t) = 1 - \cos 3t$

$\therefore \bar{f}(s) = L[f(t)] = \frac{1}{s} - \frac{s}{s^2+9}$

We have the property:  $L \frac{f(t)}{t} = \int_s^{\infty} \bar{f}(s) \, ds$

$$\begin{aligned} \text{i.e., } L \left[ \frac{1 - \cos 3t}{t} \right] &= \int_s^{\infty} \left[ \frac{1}{s} - \frac{s}{s^2+9} \right] ds \\ &= \left[ \log s - \frac{1}{2} \log (s^2+9) \right]_s^{\infty} \\ &= \left[ \log \frac{s}{\sqrt{s^2+9}} \right]_s^{\infty} \\ &= \left[ \log \frac{s}{s\sqrt{1+9/s^2}} \right]_{s=\infty}^0 - \log \frac{s}{\sqrt{s^2+9}} \\ &= \log 1 - \log \frac{s}{\sqrt{s^2+9}} = \log \frac{\sqrt{s^2+9}}{s} \\ L \left[ \frac{1 - \cos 3t}{t} \right] &= \log \left[ \frac{\sqrt{s^2+9}}{s} \right] \end{aligned}$$

5. Find the Laplace transform of the full wave rectifier  $f(t) = E \sin wt$ ,  $0 < t < \pi/w$  having period  $\pi/w$ .

**Solution.** Refer page No. 349. Example 3.

6. Express the following functions in terms of Heaviside's unit step function and hence find its Laplace transform where

$$f(t) = \begin{cases} t^2, & 0 < t \leq 2 \\ 4t, & t > 2 \end{cases}$$

**Solution.** (1) Refer page No. 356. Example 2.

7. Express the function.

$$f(t) = \begin{cases} \pi - t, & 0 < t \leq \pi \\ \sin t, & t > \pi \end{cases}$$

in terms of unit step function and hence find its Laplace transform.

**Solution.**  $f(t) = (\pi - t) + [\sin t - (\pi - t)] u(t - \pi)$

by standard property.

$$\text{i.e.,} \quad f(t) = (\pi - t) + [\sin t - \pi + t] u(t - \pi) \quad \dots(1)$$

$$L[f(t)] = L(\pi - t) + L\{[\sin t - \pi + t] u(t - \pi)\}$$

Taking  $F(t - \pi) = \sin t - \pi + t$ , we have

$$F(t) = \sin(t + \pi) - \pi + (t + \pi)$$

$$\text{i.e.,} \quad F(t) = -\sin t + t$$

$$\therefore \quad \bar{F}(s) = L[F(t)] = \frac{-1}{s^2 + 1} + \frac{1}{s^2}$$

$$\text{Also } L[F(t - \pi) u(t - \pi)] = e^{-\pi s} \bar{F}(s)$$

$$\therefore L[(\sin t - \pi + t) u(t - \pi)] = e^{-\pi s} \left( \frac{1}{s^2} - \frac{1}{s^2 + 1} \right) \quad \dots(2)$$

Thus by using (2) in (1) with

$$L(\pi - t) = \frac{\pi}{s} - \frac{1}{s^2}$$

we get

$$L[f(t)] = \left( \frac{\pi}{s} - \frac{1}{s^2} \right) + e^{-\pi s} \left( \frac{1}{s^2} - \frac{1}{s^2 + 1} \right)$$

8. Find (i)  $L[t^2 u(t - 3)]$ , (ii)  $L[e^{3t} u(t - 2)]$ .

**Solution.** (2) & (4) Refer page No. 355. Example 1.

9. Define Heaviside unit step function. Using unit step function find the Laplace transform of:

$$f(t) = \begin{cases} \sin t, & 0 \leq t < \pi \\ \sin 2t, & \pi \leq t < 2\pi \\ \sin 3t, & t > 2\pi \end{cases}$$

**Solution.** The given  $f(t)$  can be written in the following form by a standard property.

$$f(t) = \sin t + [\sin 2t - \sin t] u(t - \pi) + [\sin 3t - \sin 2t] u(t - 2\pi)$$

$$\begin{aligned} \text{Now } L[f(t)] &= L(\sin t) + L\{[\sin 2t - \sin t] u(t - \pi)\} \\ &\quad + L\{[\sin 3t - \sin 2t] u(t - 2\pi)\} \dots(1) \end{aligned}$$

Consider  $L[\sin 2t - \sin t] u(t - \pi)$

$$\text{Let } F(t - \pi) = \sin 2t - \sin t$$

$$\Rightarrow F(t) = \sin 2(t + \pi) - \sin(t + \pi)$$

$$F(t) = \sin(2\pi + 2t) - \sin(\pi + t)$$

$$\text{or } F(t) = \sin 2t + \sin t$$

$$\therefore \bar{F}(s) = L[F(t)] = \frac{2}{s^2 + 4} + \frac{1}{s^2 + 1}$$

$$\text{But } L[F(t - \pi) u(t - \pi)] = e^{-\pi s} \bar{F}(s)$$

$$\text{i.e., } L\{[\sin 2t - \sin t] u(t - \pi)\} = e^{-\pi s} \left[ \frac{2}{s^2 + 4} + \frac{1}{s^2 + 1} \right] \dots(2)$$

$$\text{Also } G(t - 2\pi) = \sin 3t - \sin 2t$$

$$\text{i.e., } G(t) = \sin 3(t + 2\pi) - \sin 2(t + 2\pi)$$

$$\text{i.e., } G(t) = \sin 3t - \sin 2t$$

$$\therefore L[G(t)] = \bar{G}(s) = \frac{3}{s^2 + 9} - \frac{2}{s^2 + 4}$$

$$\text{But } L[G(t - 2\pi) u(t - 2\pi)] = e^{-2\pi s} \bar{G}(s)$$

$$\text{i.e., } L\{(\sin 3t - \sin 2t) u(t - 2\pi)\} = e^{-2\pi s} \left[ \frac{3}{s^2 + 9} - \frac{2}{s^2 + 4} \right] \dots(3)$$

Thus (1) as a result of (2) and (3) becomes

$$L[f(t)] = \frac{1}{s^2 + 1} + e^{-\pi s} \left[ \frac{2}{s^2 + 4} + \frac{1}{s^2 + 1} \right] + e^{-2\pi s} \left[ \frac{3}{s^2 + 9} - \frac{2}{s^2 + 4} \right].$$

## OBJECTIVE QUESTIONS

1. Laplace transform of  $t^n e^{+at}$  is:

$$(a) \frac{n!}{(s+a)^n}$$

$$(b) \frac{(n+1)!}{(s+a)^{n+1}}$$

$$(c) \frac{n!}{(s-a)^{n+1}}$$

$$(d) \frac{(n+1)!}{(s+a)^{n+1}}$$

[Ans. c]

2. Laplace transform of  $f(t) = te^{at} \sin(at)$ ,  $t > 0$ .

$$(a) \frac{2a(s-a)}{\left[(s-a)^2 + a^2\right]^2}$$

$$(b) \frac{a(s-a)}{(s-a)^2 + a^2}$$

$$(c) \frac{s-a}{(s-a)^2 - a^2}$$

$$(d) \frac{(s-a)^2}{(s-a)^2 + a^2}$$

[Ans. a]

3.

The Laplace transform of  $te^{-t} \cos h 2t$  is:

$$(a) \frac{s^2 + 2s + 5}{(s^2 + 2s - 3)^2}$$

$$(b) \frac{s^2 - 2s + 5}{(s^2 + 2s - 3)^2}$$

$$(c) \frac{4s + 4}{(s^2 + 2s - 3)^2}$$

$$(d) \frac{4s - 4}{(s^2 + 2s - 3)^2}$$

[Ans. a]

$$4. L \left[ \frac{\sin t}{t} \right] =$$

$$(a) \frac{1}{s^2 + 1}$$

$$(b) \cot^{-1} s$$

$$(c) \cot^{-1} (s - 1)$$

$$(d) \tan^{-1} s$$

[Ans. b]

5. The relation between unit step function and unit impulse function is:

$$(a) L[u(t-a)] = L[\delta(t)]$$

$$(b) L[u'(t-a)] = L[\delta(t-a)]$$

$$(c) L[u(t)] = L[\delta'(t-a)]$$

$$(d) \text{None of these}$$

[Ans. b]

6. The laplace transform of  $\sin^2 3t$  is:

$$(a) \frac{3}{s^2 + 36}$$

$$(b) \frac{6}{s(s^2 + 36)}$$

$$(c) \frac{18}{s(s^2 + 36)}$$

$$(d) \frac{18}{s^2 + 36}$$

[Ans. c]

7.  $L[t^2 e^t] =$

$$(a) \frac{2}{(s-2)^2}$$

$$(b) \frac{2}{(s-2)^3}$$

$$(c) \frac{1}{(s-2)^3}$$

$$(d) \frac{1}{(s-1)^3}$$

[Ans. b]

8.  $L[e^{-t} \sin h t] =$

$$(a) \frac{1}{(s+1)^2 + 1}$$

$$(b) \frac{1}{(s-1)^2 + 1}$$

$$(c) \frac{1}{s(s+2)}$$

$$(d) \frac{s-1}{(s-1)^2 + 1}$$

[Ans. c]

9.  $L(e^{-3t} \cos 3t) =$

(a)  $\frac{s-3}{s^2-6s-18}$

(b)  $\frac{s+3}{s^2+6s+18}$

(c)  $\frac{s+3}{s^2-6s+18}$

(d)  $\frac{s-3}{s^2+6s-18}$

[Ans. b]

10.  $L[(t^2 + 1) u(t - 1)] =$

(a)  $2e^{-s} (1 + s + s^2)/s^3$

(b)  $e^{-s} (1 + s + s^2)/s^3$

(c)  $2e^s (1 + s + s^2)/s^3$

(d) None of these

[Ans. a]

11. Laplace transform of  $(t \sin t)$  is:

(a)  $\frac{2s}{(s^2+1)^2}$

(b)  $\frac{s}{s+1}$

(c)  $\frac{2s}{s^2+1}$

(d)  $\frac{2s}{(s^2-1)^2}$

[Ans. a]

12. Laplace transform of  $f(t)$ :  $t \geq 0$  is defined as:

(a)  $\int_0^1 e^{-st} f(t) dt$

(b)  $\int_0^\infty e^{-st} f(t) dt$

(c)  $\int_0^2 f(t) dt$

(d) None of these

[Ans. b]

13. A unit step function is defined as:

(a)  $u(t-a) = \begin{cases} 0, & t < a \\ 1, & t \geq a \end{cases} \quad a \geq 0$

(b)  $t - a = 0$

(c)  $u(t-a) = \begin{cases} 0, & t > a \\ 1, & t \geq a \end{cases}$

(d) None of these

[Ans. a]

14.  $L(e^{2t} \sin t)$  is:

(a)  $\frac{1}{s^2+5}$

(b)  $\frac{1}{s^2-4s}$

(c)  $\frac{1}{s^2-4s+5}$

(d) None of these

[Ans. c]

15.  $L(e^t) =$

(a)  $\frac{1}{s-\log 2}$

(b)  $\frac{1}{s+\log 2}$

(c)  $\frac{1}{s+2}$

(d) None of these

[Ans. a]

16.  $L(e^{-t} t^k)$  is:

(a)  $\frac{k!}{(s+1)^{k+1}}$

(b)  $\frac{s!}{(s+1)^{k+1}}$

(c)  $\frac{k!}{(s-1)^{k+1}}$

(d) None of these

[Ans. a]



17.  $L(\cos^3 4t) =$

(a)  $\frac{1}{3} \left( \frac{1}{s} + \frac{s}{s^2 - 16} \right)$

(b)  $\frac{1}{2} \left( \frac{1}{s} + \frac{s}{s^2 - 16} \right)$

(c)  $\frac{1}{2} \left( \frac{1}{s} - \frac{s}{s^2 + 16} \right)$

(d) None of these

[Ans. b]

18. Laplace transform of the unit impulse function  $\delta(t - a)$  is:

(a)  $e^{-as}$

(b)  $e^{as}$

(c)  $e^{-t}$

(d) None of these

[Ans. a]

19.  $L[\cos(2t + 3)] =$

(a)  $\frac{s \cos 3 - 2 \sin 3}{s^2 + 4}$

(b)  $\frac{s^2 \cos 3 - 2 \sin 3}{s^2 - 4}$

(c)  $\frac{s \cos 3 + 2 \sin 3}{s^2 - 4}$

(d) None of these

[Ans. a]

20.  $L[e^{at}]$  is:

(a)  $\frac{1}{s + a}$

(b)  $\frac{1}{s}$

(c)  $\frac{1}{s - a}$

(d) None of these

[Ans. c]

21.  $L[f'(t)]$  is:

(a)  $S L[f(t)] - f(0)$

(b)  $F(s)$

(c)  $S L[f(t)]$

(d) None of these

[Ans. a]

22.  $L\{f(t) u(t - a)\}$  is:

(a)  $e^{as} Lf(t)$

(b)  $e^{-as} L[f(t + a)]$

(c)  $f(t + a)$

(d) None of these

[Ans. b]

23. The Laplace transform of  $t^3 \delta(t - 4)$  is:

(a)  $4^3 e^{-4s}$

(b)  $3^4 e^{3s}$

(c)  $e^{4s} 3^2$

(d) None of these

[Ans. a]

24.  $L[e^{iat}]$  is:

(a)  $\frac{1}{s + ia}$

(b)  $\frac{1}{s - ia}$

(c)  $\frac{1}{s}$

(d) None of these

[Ans. b]

25. The Laplace transform of  $(1 + \cos 2t)$  is:

(a)  $\frac{1}{s} + \frac{s}{s^2 + 4}$

(b)  $\frac{1}{s} - \frac{s}{s^2 - 4}$

(c)  $\frac{1}{s^2} + \frac{1}{s}$

(d) None of these

[Ans. a]

□□□

## Inverse Laplace Transforms

---

### 8.1 INTRODUCTION

If  $L\{f(t)\} = F(s)$ , then  $f(t)$  is called the Inverse Laplace Transform of  $F(s)$  and symbolically, we write  $f(t) = L^{-1}\{F(s)\}$ . Here  $L^{-1}$  is called the inverse Laplace transform operator.

For example,

$$(i) \quad L(e^{at}) = \frac{1}{s-a}, \quad s > a, \quad L^{-1}\left\{\frac{1}{s-a}\right\} = e^{at}$$

$$(ii) \quad L(t) = \frac{1}{s^2}, \quad L^{-1}\left\{\frac{1}{s^2}\right\} = t$$

### 8.2 INVERSE LAPLACE TRANSFORMS OF SOME STANDARD FUNCTIONS

1. Since  $L(1) = \frac{1}{s}, \quad L^{-1}\left\{\frac{1}{s}\right\} = 1.$

2.  $L(e^{at}) = \frac{1}{s-a}, \quad s > a, \quad L^{-1}\left\{\frac{1}{s-a}\right\} = e^{at}.$

Replacing  $a$  by  $-a$ , we get  $L^{-1}\left\{\frac{1}{s+a}\right\} = e^{-at}.$

3.  $L(\sin at) = \frac{a}{s^2+a^2}, \quad L^{-1}\left\{\frac{a}{s^2+a^2}\right\} = \sin at.$

$$L^{-1}\left\{\frac{1}{s^2+a^2}\right\} = \frac{\sin at}{a}.$$

4.  $L(\cos at) = \frac{s}{s^2+a^2}, \quad L^{-1}\left\{\frac{s}{s^2+a^2}\right\} = \cos at.$

$$5. \quad L(\sin h at) = \frac{a}{s^2 - a^2}, \quad L^{-1}\left\{\frac{a}{s^2 - a^2}\right\} = \sin h at.$$

$$L^{-1}\left\{\frac{1}{s^2 - a^2}\right\} = \frac{\sin h at}{a}.$$

$$6. \quad L(\cos h at) = \frac{s}{s^2 - a^2}, \quad L^{-1}\left\{\frac{s}{s^2 - a^2}\right\} = \cos h at.$$

$$7. \quad L(t^n) = \frac{n!}{s^{n+1}} \text{ where } n \text{ is a positive integer, we get}$$

$$L^{-1}\left\{\frac{n!}{s^{n+1}}\right\} = t^n$$

$$L^{-1}\left\{\frac{1}{s^{n+1}}\right\} = \frac{t^n}{n!}.$$

$$\text{Replacing } n \text{ by } n - 1, \text{ we get } L^{-1}\left\{\frac{1}{s^n}\right\} = \frac{t^{n-1}}{(n-1)!}$$

$$\text{In particular, } L^{-1}\left\{\frac{1}{s}\right\} = 1$$

$$L^{-1}\left\{\frac{1}{s^2}\right\} = \frac{t^{2-1}}{(2-1)!} = t$$

$$L^{-1}\frac{1}{s^3} = \frac{t^{3-1}}{(3-1)!} = \frac{t^2}{2}$$

$$\text{Since, } L(t^n) = \frac{\Gamma(n+1)}{s^{n+1}}, \quad L^{-1}\left\{\frac{1}{s^{n+1}}\right\} = \frac{t^n}{\Gamma(n+1)}, n > -1.$$

The following table gives list of the Inverse Laplace Transform of some standard functions.

S.No.	$F(s)$	$f(t) = L^{-1}\{F(s)\}$	S.No.	$F(s)$	$f(t) = L^{-1}\{F(s)\}$
1.	$\frac{1}{s-a}$	$e^{at}$	6.	$\frac{s}{s^2 - a^2}$	$\cos h at$
2.	$\frac{1}{s+a}$	$e^{-at}$	7.	$\frac{1}{s}$	1
3.	$\frac{1}{s^2 + a^2}$	$\frac{\sin at}{a}$	8.	$\frac{1}{s^2}$	$t$
4.	$\frac{s}{s^2 + a^2}$	$\cos at$	9.	$\frac{1}{s^n}, n = 1, 2, \dots$	$\frac{t^{n-1}}{(n-1)!}$
5.	$\frac{1}{s^2 - a^2}$	$\frac{\sin h at}{a}$	10.	$\frac{1}{s^{n+1}}, n > -1$	$\frac{t^n}{\Gamma(n+1)}$

Following properties immediately follow from the corresponding properties of the Laplace transform.

### Properties of inverse Laplace transform

#### 1. Linearity Property

If  $a$  and  $b$  are two constants then

$$L^{-1} \{a F(s) + b G(s)\} = a L^{-1}\{F(s)\} + b L^{-1}\{G(s)\}$$

This result can be extended to more than two functions. This shows that like  $L$ ,  $L^{-1}$  is also a linear operator.

**Example:** 
$$L^{-1} \left\{ \frac{2}{s-3} - \frac{3s}{s^2+16} + \frac{4}{s^2-9} \right\}$$

$$= 2 L^{-1} \left\{ \frac{1}{s-3} \right\} - 3 L^{-1} \left\{ \frac{s}{s^2+4^2} \right\} + 4 L^{-1} \left\{ \frac{1}{s^2-3^2} \right\}$$

$$= 2 e^{3t} - 3 \cos 4t + 4 \frac{\sinh 3t}{3}.$$

#### 2. Shifting Property

If  $L^{-1}\{F(s)\} = f(t)$ , then

$$L^{-1}\{F(s-a)\} = e^{at} f(t) = e^{at} L^{-1}\{F(s)\}$$

This follows immediately from the result.

If  $L\{f(t)\} = F(s)$ , then  $L\{e^{at} f(t)\} = F(s-a)$

Replacing  $a$  by  $-a$ , we get

$$L^{-1}\{F(s+a)\} = e^{-at} f(t) = e^{-at} L^{-1}\{F(s)\}.$$

**Examples:**

(i) 
$$L^{-1} \left\{ \frac{1}{s^2-2s+5} \right\} = L^{-1} \left\{ \frac{1}{(s-1)^2+2^2} \right\}$$

$$= e^t L^{-1} \left\{ \frac{1}{s^2+2^2} \right\}$$

$$= e^t \frac{\sin 2t}{2}$$

$$= \frac{1}{2} e^t \sin 2t.$$

(ii) 
$$L^{-1} \left\{ \frac{s-3}{s^2-6s+13} \right\} = L^{-1} \left\{ \frac{s-3}{(s-3)^2+2^2} \right\}$$

$$= e^{3t} L^{-1} \left\{ \frac{s}{s^2+2^2} \right\}$$

$$= e^{3t} \cos 2t.$$

### WORKED OUT EXAMPLES

1. Find the inverse Laplace transforms of the following functions:

$$(i) \frac{1}{2s-3} \quad (ii) \frac{1}{4s+5} \quad (iii) \frac{1}{s^2+9} \quad (iv) \frac{s}{s^2-16}$$

$$(v) \frac{s}{9s^2+4} \quad (vi) \frac{1}{16s^2-9} \quad (vii) \frac{(s+2)^3}{s^6} \quad (viii) \frac{2s+18}{s^2+25}$$

$$(ix) \frac{8-6s}{16s^2+9} \quad (x) \frac{1}{s^{3/2}}$$

**Solution**

$$(i) \quad L^{-1} \left\{ \frac{1}{2s-3} \right\} = L^{-1} \left\{ \frac{1}{2 \left( s - \frac{3}{2} \right)} \right\} = \frac{1}{2} L^{-1} \left\{ \frac{1}{s - \frac{3}{2}} \right\} = \frac{1}{2} e^{\frac{3}{2}t}$$

$$(ii) \quad L^{-1} \left\{ \frac{1}{4s+5} \right\} = L^{-1} \left\{ \frac{1}{4 \left( s + \frac{5}{4} \right)} \right\} \\ = \frac{1}{4} L^{-1} \left\{ \frac{1}{s + \frac{5}{4}} \right\} = \frac{1}{4} e^{-\left(\frac{5}{4}\right)t}$$

$$(iii) \quad L^{-1} \left\{ \frac{1}{s^2+9} \right\} = L^{-1} \left\{ \frac{1}{s^2+3^2} \right\} \\ = \frac{1}{3} \sin 3t.$$

$$(iv) \quad L^{-1} \left\{ \frac{s}{s^2-16} \right\} = L^{-1} \left\{ \frac{s}{s^2-4^2} \right\} \\ = \cos h 4t.$$

$$(v) \quad L^{-1} \left\{ \frac{s}{9s^2+4} \right\} = \frac{1}{9} L^{-1} \left\{ \frac{s}{s^2 + \left(\frac{2}{3}\right)^2} \right\} \\ = \frac{1}{9} \cos \left( \frac{2}{3} t \right).$$

$$(vi) \quad L^{-1} \left\{ \frac{1}{16s^2-9} \right\} = L^{-1} \left\{ \frac{1}{16 \left( s^2 - \frac{9}{16} \right)} \right\} \\ = \frac{1}{16} L^{-1} \left\{ \frac{1}{s^2 - \left(\frac{3}{4}\right)^2} \right\}$$

$$= \frac{1}{16} \frac{1}{\left(\frac{3}{4}\right)} \cdot \sin h\left(\frac{3}{4}t\right)$$

$$= \frac{1}{12} \sin h\left(\frac{3}{4}t\right).$$

(vii)

$$L^{-1}\left\{\frac{(s+2)^3}{s^6}\right\} = L^{-1}\left\{\frac{s^3 + 6s^2 + 12s + 8}{s^6}\right\}$$

$$= L^{-1}\left\{\frac{1}{s^3} + \frac{6}{s^4} + \frac{12}{s^5} + \frac{8}{s^6}\right\}$$

$$= L^{-1}\left\{\frac{1}{s^3}\right\} + 6 L^{-1}\left\{\frac{1}{s^4}\right\} + 12 L^{-1}\left\{\frac{1}{s^5}\right\} + 8 L^{-1}\left\{\frac{1}{s^6}\right\}$$

$$= \frac{t^2}{2!} + 6 \frac{t^3}{3!} + 12 \frac{t^4}{4!} + 8 \frac{t^5}{5!}$$

$$= \frac{t^2}{2} + t^3 + \frac{t^4}{2} + \frac{t^5}{15}.$$

(viii)

$$L^{-1}\left\{\frac{2s+18}{s^2+25}\right\} = 2 L^{-1}\left\{\frac{s}{s^2+25}\right\} + 18 L^{-1}\left\{\frac{1}{s^2+25}\right\}$$

$$= 2 L^{-1}\left\{\frac{s}{s^2+5^2}\right\} + 18 L^{-1}\left\{\frac{1}{s^2+5^2}\right\}$$

$$= 2 \cos 5t + \frac{18}{5} \sin 5t.$$

(ix)

$$L^{-1}\left\{\frac{8-6s}{16s^2+9}\right\} = 8 L^{-1}\left\{\frac{1}{16s^2+9}\right\} - 6 L^{-1}\left\{\frac{s}{16s^2+9}\right\}$$

$$= 8 L^{-1}\left\{\frac{1}{16\left(s^2 + \frac{9}{16}\right)}\right\} - 6 L^{-1}\left\{\frac{s}{16\left(s^2 + \frac{9}{16}\right)}\right\}$$

$$= \frac{8}{16} L^{-1}\left\{\frac{1}{s^2 + \left(\frac{3}{4}\right)^2}\right\} - \frac{6}{16} L^{-1}\left\{\frac{s}{s^2 + \left(\frac{3}{4}\right)^2}\right\}$$

$$= \frac{2}{3} \frac{1}{\left(\frac{3}{4}\right)} \sin\left(\frac{3}{4}t\right) - \frac{3}{8} \cos\left(\frac{3}{4}t\right)$$

$$= \frac{8}{9} \sin\left(\frac{3}{4}t\right) - \frac{3}{8} \cos\left(\frac{3}{4}t\right).$$

$$(x) \quad L^{-1} \frac{1}{s^{n+1}} = \frac{t^n}{\Gamma(n+1)}$$

or 
$$L^{-1} \left\{ \frac{1}{s^n} \right\} = \frac{t^{n-1}}{\Gamma(n)}$$

we have, 
$$L^{-1} \left\{ \frac{1}{s^{3/2}} \right\} = \frac{t^{3/2-1}}{\Gamma\left(\frac{3}{2}\right)} = \frac{t^{1/2}}{\Gamma\left(\frac{1}{2}+1\right)} = \frac{t^{1/2}}{\frac{1}{2}\Gamma\left(\frac{1}{2}\right)}$$

$$= \frac{2\sqrt{t}}{\sqrt{\pi}} \quad \left( \text{where } \Gamma\left(\frac{1}{2}\right) = \sqrt{\pi} \right)$$

2. Find the inverse Laplace transforms of the following functions:

$$(i) \quad \frac{3}{(s-2)^4}$$

$$(ii) \quad \frac{1}{s^2 + 4s + 20}$$

$$(iii) \quad \frac{s+2}{s^2 + 8s + 25}$$

$$(iv) \quad \frac{2s-3}{s^2 - 2s + 5}$$

$$(v) \quad \frac{s}{4s^2 + 12s + 5}$$

$$(vi) \quad \frac{s+3}{4s^2 + 4s + 9}$$

**Solutions.** Using the shifting rule, we have

$$(i) \quad L^{-1} \left\{ \frac{3}{(s-2)^4} \right\} = 3e^{2t} L^{-1} \left\{ \frac{1}{s^4} \right\} \quad s \rightarrow s-2$$

$$= 3e^{2t} \cdot \frac{t^3}{3!} = \frac{t^3 e^{2t}}{2}$$

$$(ii) \quad L^{-1} \left\{ \frac{1}{s^2 + 4s + 20} \right\} = L^{-1} \left\{ \frac{1}{(s+2)^2 + 4^2} \right\}$$

$$= e^{-2t} L^{-1} \left\{ \frac{1}{s^2 + 4^2} \right\}$$

$$= e^{-2t} \frac{1}{4} \sin 4t$$

$$= \frac{1}{4} e^{-2t} \sin 4t$$

$$(iii) \quad L^{-1} \left\{ \frac{s+2}{s^2 + 8s + 25} \right\} = L^{-1} \left\{ \frac{(s+4)-2}{(s+4)^2 + 3^2} \right\} \quad s \rightarrow s+4$$

$$= e^{-4t} L^{-1} \left\{ \frac{s-2}{s^2 + 3^2} \right\}$$

$$= e^{-4t} \left[ L^{-1} \left\{ \frac{s}{s^2 + 3^2} \right\} - 2 L^{-1} \left\{ \frac{1}{s^2 + 3^2} \right\} \right]$$

$$= e^{-4t} \left[ \cos 3t - \frac{2}{3} \sin 3t \right]$$

$$\begin{aligned}
 (iv) \quad L^{-1} \left\{ \frac{2s-3}{s^2-2s+5} \right\} &= L^{-1} \left\{ \frac{2(s-1)-1}{(s-1)^2+2^2} \right\} && (s-1 \rightarrow s) \\
 &= e^t L^{-1} \left\{ \frac{2s-1}{s^2+2^2} \right\} \\
 &= e^t \left[ 2 L^{-1} \left\{ \frac{s}{s^2+2^2} \right\} - L^{-1} \left\{ \frac{1}{s^2+2^2} \right\} \right] \\
 &= e^t \left[ 2 \cos 2t - \frac{1}{2} \sin 2t \right].
 \end{aligned}$$

$$\begin{aligned}
 (v) \quad L^{-1} \left\{ \frac{s}{4s^2+12s+5} \right\} &= L^{-1} \left\{ \frac{s}{4 \left( s^2+3s+\frac{5}{4} \right)} \right\} \\
 &= \frac{1}{4} L^{-1} \left\{ \frac{s}{s^2+3s+\frac{5}{4}} \right\}
 \end{aligned}$$

$$\begin{aligned}
 \text{Now,} \quad s^2+3s+\frac{5}{4} &= \left( s^2+2 \cdot \frac{3}{2} \cdot s + \frac{9}{4} \right) + \frac{5}{4} - \frac{9}{4} \\
 &= \left( s + \frac{3}{2} \right)^2 - 1
 \end{aligned}$$

$$\begin{aligned}
 \therefore L^{-1} \left\{ \frac{s}{4s^2+12s+5} \right\} &= \frac{1}{4} L^{-1} \left\{ \frac{\left( s + \frac{3}{2} \right) - \frac{3}{2}}{\left( s + \frac{3}{2} \right)^2 - 1} \right\} \\
 &= \frac{1}{4} e^{-(3/2)t} L^{-1} \left\{ \frac{s - \frac{3}{2}}{s^2 - 1} \right\} \\
 &= \frac{1}{4} e^{-(3/2)t} \left[ L^{-1} \left\{ \frac{s}{s^2-1} \right\} - \frac{3}{2} L^{-1} \left\{ \frac{1}{s^2-1} \right\} \right] \\
 &= \frac{1}{4} e^{-(3/2)t} \left[ \cos ht - \frac{3}{2} \sin ht \right].
 \end{aligned}$$

$$\begin{aligned}
 (vi) \quad L^{-1} \left\{ \frac{s+3}{4s^2+4s+9} \right\} &= L^{-1} \left\{ \frac{s+3}{4 \left( s^2+s+\frac{9}{4} \right)} \right\} \\
 &= \frac{1}{4} L^{-1} \left\{ \frac{s+3}{s^2+s+\frac{9}{4}} \right\}
 \end{aligned}$$



$$\begin{aligned}
\text{Now, } s^2 + s + \frac{9}{4} &= \left[ s^2 + 2 \cdot s \cdot \frac{1}{2} + \left( \frac{1}{2} \right)^2 \right] + \frac{9}{4} - \frac{1}{4} \\
&= \left( s + \frac{1}{2} \right)^2 + 2 \\
\therefore \frac{1}{4} L^{-1} \left\{ \frac{s+3}{\left( s + \frac{1}{2} \right)^2 + 2} \right\} &= \frac{1}{4} L^{-1} \left\{ \frac{\left( s + \frac{1}{2} \right) + \frac{5}{2}}{\left( s + \frac{1}{2} \right)^2 + (\sqrt{2})^2} \right\} \\
&= \frac{1}{4} e^{-(1/2)t} L^{-1} \left\{ \frac{s + \frac{5}{2}}{s^2 + (\sqrt{2})^2} \right\} \\
&= \frac{1}{4} e^{-(1/2)t} \left[ L^{-1} \left\{ \frac{s}{s^2 + (\sqrt{2})^2} \right\} + \frac{5}{2} L^{-1} \left\{ \frac{1}{s^2 + (\sqrt{2})^2} \right\} \right] \\
&= \frac{1}{4} e^{-(1/2)t} \left[ \cos \sqrt{2} t + \frac{5}{2\sqrt{2}} \sin \sqrt{2} t \right].
\end{aligned}$$

### 8.3 INVERSE LAPLACE TRANSFORMS USING PARTIAL FRACTIONS

In this method we first resolve the given rational function of  $s$  into partial fractions and then find the inverse Laplace transform of each fraction.

3. Find the inverse Laplace transforms of the following functions:

$$\begin{array}{ll}
(i) \frac{2s-1}{s^2-5s+6} & (ii) \frac{s}{(2s-1)(3s-1)} \\
(iii) \frac{2s-3}{(s-1)(s-2)(s-3)} & (iv) \frac{4s+5}{(s-1)^2(s+2)} \\
(v) \frac{3s-1}{(s-3)(s^2+4)} & (vi) \frac{s^2}{(s^2+4)(s^2+9)}.
\end{array}$$

**Solution**

$$\begin{aligned}
(i) \text{ Let } \frac{2s-1}{s^2-5s+6} &= \frac{2s-1}{(s-2)(s-3)} = \frac{A}{s-2} + \frac{B}{s-3} \\
2s-1 &= A(s-3) + B(s-2) \\
\text{Put } s &= 3, \quad B = 5 \\
\text{Put } s &= 2, \quad A = -3 \\
\therefore \frac{2s-1}{s^2-5s+6} &= -\frac{3}{s-2} + \frac{5}{s-3}
\end{aligned}$$

Then 
$$L^{-1} \left\{ \frac{2s-1}{s^2-5s+6} \right\} = -3 L^{-1} \left\{ \frac{1}{s-2} \right\} + 5 L^{-1} \left\{ \frac{1}{s-3} \right\}$$

$$= -3e^{2t} + 5e^{3t}.$$

(ii) Let 
$$\frac{s}{(2s-1)(3s-1)} = \frac{A}{2s-1} + \frac{B}{3s-1}$$

$$s = A(3s-1) + B(2s-1)$$

Put 
$$s = \frac{1}{2}, \quad A = 1, \quad \text{and} \quad s = \frac{1}{3}, \quad B = -1$$

$$\frac{s}{(2s-1)(3s-1)} = \frac{1}{2s-1} - \frac{1}{3s-1}$$

$$\begin{aligned} \therefore L^{-1} \left\{ \frac{s}{(2s-1)(3s-1)} \right\} &= L^{-1} \left\{ \frac{1}{2s-1} \right\} - L^{-1} \left\{ \frac{1}{3s-1} \right\} \\ &= L^{-1} \left\{ \frac{1}{2 \left( s - \frac{1}{2} \right)} \right\} - L^{-1} \left\{ \frac{1}{3 \left( s - \frac{1}{3} \right)} \right\} \\ &= \frac{1}{2} L^{-1} \left\{ \frac{1}{s - \frac{1}{2}} \right\} - \frac{1}{3} L^{-1} \left\{ \frac{1}{s - \frac{1}{3}} \right\} \\ &= \frac{1}{2} e^{\frac{1}{2}t} - \frac{1}{3} e^{\frac{1}{3}t}. \end{aligned}$$

(iii) Let 
$$\frac{2s-3}{(s-1)(s-2)(s-3)} = \frac{A}{s-1} + \frac{B}{s-2} + \frac{C}{s-3}$$

$$2s-3 = A(s-2)(s-3) + B(s-1)(s-3) + C(s-1)(s-2)$$

Put 
$$s = 1, \quad \Rightarrow A = \frac{-1}{2}$$

$$s = 3, \quad \Rightarrow C = \frac{3}{2}$$

$$s = 2, \quad \Rightarrow B = -1$$

Thus, 
$$\frac{2s-3}{(s-1)(s-2)(s-3)} = \frac{-\frac{1}{2}}{s-1} - \frac{1}{s-2} + \frac{\frac{3}{2}}{s-3}$$

$$\begin{aligned} L^{-1} \left\{ \frac{2s-3}{(s-1)(s-2)(s-3)} \right\} &= \frac{-1}{2} L^{-1} \left\{ \frac{1}{s-1} \right\} - L^{-1} \left\{ \frac{1}{s-2} \right\} + \frac{3}{2} L^{-1} \left\{ \frac{1}{s-3} \right\} \\ &= \frac{-1}{2} e^t - e^{2t} + \frac{3}{2} e^{3t}. \end{aligned}$$

$$(iv) \text{ Let } \frac{4s+5}{(s-1)^2(s+2)} = \frac{A}{s-1} + \frac{B}{(s-1)^2} + \frac{C}{s+2}$$

$$4s+5 = A(s-1)(s+2) + B(s+2) + C(s-1)^2$$

$$\text{Put } s=1, \Rightarrow B=3$$

$$s=-2, \Rightarrow C = \frac{-1}{3}$$

To find A, put  $s=0$ ,

$$\text{Then } 5 = -2A + 2B + C$$

$$\text{This gives } A = \frac{1}{3}$$

Thus the partial fraction is

$$\frac{4s+5}{(s-1)^2(s+2)} = \frac{\frac{1}{3}}{s-1} + \frac{3}{(s-1)^2} - \frac{\frac{1}{3}}{s+2}$$

$$\begin{aligned} \therefore L^{-1} \left\{ \frac{4s+5}{(s-1)^2(s+2)} \right\} &= \frac{1}{3} L^{-1} \left\{ \frac{1}{s-1} \right\} + 3 L^{-1} \left\{ \frac{1}{(s-1)^2} \right\} - \frac{1}{3} L^{-1} \left\{ \frac{1}{s+2} \right\} \\ &= \frac{1}{3} e^t + 3e^t \left[ L^{-1} \left\{ \frac{1}{s^2} \right\} \right] - \frac{1}{3} e^{-2t} \\ &= \frac{1}{3} e^t + 3e^t \cdot t - \frac{1}{3} e^{-2t} \\ &= \frac{1}{3} e^t + 3t e^t - \frac{1}{3} e^{-2t}. \end{aligned}$$

$$(v) \text{ Let } \frac{3s-1}{(s-3)(s^2+4)} = \frac{A}{s-3} + \frac{Bs+C}{s^2+4}$$

$$\text{Then } 3s-1 = A(s^2+4) + (Bs+C)(s-3)$$

$$\text{Put } s=3 \quad A = \frac{8}{13}$$

$$\text{Now, } 3s-1 = (A+B)s^2 + (-3B+C)s + (4A-3C)$$

Comparing the coefficients, we get

$$A+B=0, \quad -3B+C=3, \quad 4A-3C=-1$$

$$A = \frac{8}{13}, \quad B = \frac{-8}{13}, \quad C = \frac{15}{13}$$

$$\begin{aligned} \therefore \frac{3s-1}{(s-3)(s^2+4)} &= \frac{\frac{8}{13}}{s-3} + \frac{\frac{-8}{13}s + \frac{15}{13}}{s^2+4} \\ &= \frac{8}{13} \cdot \frac{1}{s-3} - \frac{1}{13} \frac{8s-15}{s^2+4} \end{aligned}$$

$$\begin{aligned}
 \therefore L^{-1} \left\{ \frac{3s-1}{(s-3)(s^2+4)} \right\} &= \frac{8}{13} L^{-1} \left\{ \frac{1}{s-3} \right\} - \frac{1}{13} L^{-1} \left\{ \frac{8s-15}{s^2+4} \right\} \\
 &= \frac{8}{13} e^{3t} - \frac{1}{13} \left[ 8 L^{-1} \left\{ \frac{s}{s^2+4} \right\} - 15 L^{-1} \left\{ \frac{1}{s^2+4} \right\} \right] \\
 &= \frac{8}{13} e^{3t} - \frac{1}{13} \left[ 8 L^{-1} \left\{ \frac{s}{s^2+2^2} \right\} - 15 L^{-1} \left\{ \frac{1}{s^2+2^2} \right\} \right] \\
 &= \frac{8}{13} e^{3t} - \frac{1}{13} \left[ 8 \cos 2t - \frac{15}{2} \sin 2t \right].
 \end{aligned}$$

(vi) Let  $s^2 = x$ , then

$$\begin{aligned}
 \frac{x}{(x+4)(x+9)} &= \frac{A}{x+4} + \frac{B}{x+9} \\
 x &= A(x+9) + B(x+4)
 \end{aligned}$$

Put  $x = -4$ ,  $A = \frac{-4}{5}$

$x = -9$ ,  $B = \frac{9}{5}$

$$\therefore \frac{x}{(x+4)(x+9)} = \frac{\frac{-4}{5}}{x+4} + \frac{\frac{9}{5}}{x+9}$$

*i.e.*, 
$$\frac{s^2}{(s^2+4)(s^2+9)} = \frac{\frac{-4}{5}}{s^2+4} + \frac{\frac{9}{5}}{s^2+9}$$

$$\begin{aligned}
 L^{-1} \left\{ \frac{s^2}{(s^2+4)(s^2+9)} \right\} &= \frac{-4}{5} L^{-1} \left\{ \frac{1}{s^2+4} \right\} + \frac{9}{5} L^{-1} \left\{ \frac{1}{s^2+9} \right\} \\
 &= \frac{-4}{5} L^{-1} \left\{ \frac{1}{s^2+2^2} \right\} + \frac{9}{5} L^{-1} \left\{ \frac{1}{s^2+3^2} \right\} \\
 &= \frac{-4}{5} \cdot \frac{1}{2} \sin 2t + \frac{9}{5} \cdot \frac{1}{3} \sin 3t \\
 &= \frac{-2}{5} \sin 2t + \frac{3}{5} \sin 3t.
 \end{aligned}$$

4. Find the inverse Laplace transforms of the following functions:

(i)  $\frac{s^2 + 2s - 4}{s^4 + 2s^3 + s^2}$

(ii)  $\frac{s}{s^4 + s^2 + 1}$

**Solution**

$$(i) \text{ Now } \frac{s^2 + 2s - 4}{s^4 + 2s^3 + s^2} = \frac{s^2 + 2s - 4}{s^2 (s^2 + 2s + 1)} = \frac{s^2 + 2s - 4}{s^2 (s + 1)^2}$$

$$\frac{s^2 + 2s - 4}{s^2 (s + 1)^2} = \frac{A}{s} + \frac{B}{s^2} + \frac{C}{s + 1} + \frac{D}{(s + 1)^2}$$

$$\text{Hence, } s^2 + 2s - 4 = A (s) (s + 1)^2 + B (s + 1)^2 + C s^2 (s + 1) + D s^2$$

$$\text{Put } s = 0, \quad B = -4$$

$$s = -1, \quad D = -5$$

$$\text{Now, } s^2 + 2s - 4 = (A + C) s^3 + (2A + B + C + D) s^2 + (A + 2B) s + B$$

Comparing the coefficient, we get

$$A + C = 0, \quad 2A + B + C + D = 1, \quad A + 2B = 2, \quad B = -4$$

$$\text{Hence } A = 10, \quad C = -10$$

$$\therefore \frac{s^2 + 2s - 4}{s^4 + 2s^3 + s^2} = \frac{10}{s} - \frac{4}{s^2} - \frac{10}{s + 1} - \frac{5}{(s + 1)^2}$$

$$\begin{aligned} L^{-1} \left[ \frac{s^2 + 2s - 4}{s^4 + 2s^3 + s^2} \right] &= 10 L^{-1} \left\{ \frac{1}{s} \right\} - 4 L^{-1} \left\{ \frac{1}{s^2} \right\} - 10 L^{-1} \left\{ \frac{1}{s + 1} \right\} - 5 L^{-1} \left\{ \frac{1}{(s + 1)^2} \right\} \\ &= 10 \cdot 1 - 4 \cdot t - 10e^{-t} - 5e^{-t} L^{-1} \left\{ \frac{1}{s^2} \right\} \\ &= 10 - 4t - 10e^{-t} - 5t e^{-t}. \end{aligned}$$

$$(ii) \text{ Since, } s^4 + s^2 + 1 = (s^2 + 1)^2 - s^2 \\ = (s^2 + 1 - s) (s^2 + 1 + s)$$

$$\text{We have, } \frac{s}{s^4 + s^2 + 1} = \frac{s}{(s^2 + 1 - s)(s^2 + 1 + s)}$$

$$= \frac{1}{2} \frac{(s^2 + s + 1) - (s^2 - s + 1)}{(s^2 + s + 1)(s^2 - s + 1)}$$

$$= \frac{1}{2} \left[ \frac{1}{s^2 - s + 1} - \frac{1}{s^2 + s + 1} \right]$$

$$= \frac{1}{2} \left[ \frac{1}{\left( s - \frac{1}{2} \right)^2 + \frac{3}{4}} - \frac{1}{\left( s + \frac{1}{2} \right)^2 + \frac{3}{4}} \right]$$

$$\text{Hence, } L^{-1} \left\{ \frac{s}{s^4 + s^2 + 1} \right\} = \frac{1}{2} \left[ L^{-1} \left\{ \frac{1}{\left( s - \frac{1}{2} \right)^2 + \frac{3}{4}} \right\} - L^{-1} \left\{ \frac{1}{\left( s + \frac{1}{2} \right)^2 + \frac{3}{4}} \right\} \right]$$

$$\begin{aligned}
 &= \frac{1}{2} \left[ e^{(1/2)t} L^{-1} \left\{ \frac{1}{s^2 + \left(\frac{\sqrt{3}}{2}\right)^2} \right\} - e^{(-1/2)t} L^{-1} \left\{ \frac{1}{s^2 + \left(\frac{\sqrt{3}}{2}\right)^2} \right\} \right] \\
 &= \frac{1}{2} \left[ e^{(1/2)t} \frac{2}{\sqrt{3}} \sin \frac{\sqrt{3}}{2} t - e^{(-1/2)t} \frac{2}{\sqrt{3}} \sin \frac{\sqrt{3}}{2} t \right] \\
 &= \frac{1}{\sqrt{3}} \left[ e^{(1/2)t} - e^{(-1/2)t} \right] \sin \frac{\sqrt{3}}{2} t.
 \end{aligned}$$

5. Show that  $\int_0^\infty e^{-x^2} dx = \frac{\sqrt{\pi}}{2}$ .

**Solution**

Let  $f(t) = \int_0^\infty e^{-tx^2} dx$

$$\begin{aligned}
 \therefore L\{f(t)\} &= \int_0^\infty e^{-st} \left[ \int_0^\infty e^{-tx^2} dx \right] dt \\
 &= \int_0^\infty \left[ \int_0^\infty e^{-st} \cdot e^{-tx^2} dt \right] dx
 \end{aligned}$$

Since,  $L\{e^{-tx^2}\} = \frac{1}{1+x^2}$

$$\begin{aligned}
 &= \int_0^\infty \frac{1}{s+x^2} dx = \int_0^\infty \frac{1}{(\sqrt{s})^2 + x^2} dx \\
 &= \left[ \frac{1}{\sqrt{s}} \tan^{-1} \frac{x}{\sqrt{s}} \right]_0^\infty \\
 &= \frac{\pi}{2\sqrt{s}}
 \end{aligned}$$

Hence,  $f(t) = \frac{\pi}{2} L^{-1} \left\{ \frac{1}{\sqrt{s}} \right\}$

$$= \frac{\pi}{2} \frac{t^{\frac{1}{2}-1}}{\Gamma\left(\frac{1}{2}\right)}$$

Since,  $L^{-1} \left\{ \frac{1}{s^n} \right\} = \frac{t^{n-1}}{\Gamma(n)}$

$$\int_0^\infty e^{-tx^2} dx = \frac{\pi}{2} \frac{t^{-\frac{1}{2}}}{\sqrt{\pi}}$$

$$= \frac{\sqrt{\pi}}{2} \cdot \frac{1}{\sqrt{t}}$$

Taking

 $t = 1$ , We get

$$\int_0^{\infty} e^{-x^2} dx = \frac{\sqrt{\pi}}{2}.$$

### EXERCISE 8.1

Find the inverse Laplace transforms of the following functions:

- |                                |   |                                     |   |
|--------------------------------|---|-------------------------------------|---|
| 1. $\frac{2}{s^3}$ .           | [Ans. $t^2$ ]                             | 2. $\frac{1}{s^2 + 16}$ .           | [Ans. $\frac{1}{4} \sin 4t$ ]   |
| 3. $\frac{s}{s^2 + 9}$ .       | [Ans. $\cos 3t$ ]                         | 4. $\frac{1}{s^2 - 4}$ .            | [Ans. $\frac{1}{2} \sin h 2t$ ]   |
| 5. $\frac{s}{s^2 - 3}$ .       | [Ans. $\cos h \sqrt{3} t$ ]               | 6. $\frac{1}{s+6}$ .                | [Ans. $e^{-6t}$ ]   |
| 7. $\frac{1}{2s-1}$ .          | [Ans. $\frac{1}{2} e^{(1/2)t}$ ]          | 8. $\frac{1}{4s^2 + 9}$ .           | [Ans. $\frac{1}{6} \sin \frac{3}{2} t$ ]                                    |
| 9. $\frac{2s-1}{s^2 + 25}$ .   | [Ans. $2 \cos 5t - \frac{1}{5} \sin 5t$ ] | 10. $\frac{24 - 30\sqrt{s}}{s^4}$ . | [Ans. $4t^3 - \frac{16}{\sqrt{\pi}} t^{5/2}$ ]                              |
| 11. $\frac{5s+4}{s^3}$ .       | [Ans. $5t + 2t^2$ ]                       | 12. $\frac{8-6s}{16s^2 + 9}$ .      | [Ans. $\frac{2}{3} \sin \frac{3t}{4} - \frac{3}{8} \cos \frac{3t}{4}$ ]     |
| 13. $\frac{2s+3}{4s^2 + 20}$ . |   |                                     | [Ans. $\frac{1}{2} \cos \sqrt{5} t + \frac{3}{4\sqrt{5}} \sin \sqrt{5} t$ ] |
| 14. $\frac{3s-4}{4s^2 - 1}$ .  |   |                                     | [Ans. $\frac{3}{4} \cos h \frac{t}{2} - 2 \sin h \frac{t}{2}$ ]             |
| 15. $\frac{1-3s}{4s^2 + 9}$ .  |   |                                     | [Ans. $\frac{1}{6} \sin \frac{3t}{2} - \frac{3}{4} \cos \frac{3t}{2}$ ]     |

Find the inverse Laplace transforms of the following functions:

- |                                   |  |  |  |
|-----------------------------------|--|--|--|
| 1. $\frac{1}{(s-3)^3}$ .          |  |  | [Ans. $\frac{1}{2} t^2 e^{3t}$ ]                                   |
| 2. $\frac{s}{s^2 + 6s - 7}$ .     |  |  | [Ans. $e^{-3t} \left( \cos h 4t - \frac{3}{4} \sin h 4t \right)$ ] |
| 3. $\frac{2s+3}{s^2 - 4s + 40}$ . |  |  | [Ans. $e^{2t} \left( 2 \cos 6t + \frac{7}{6} \sin 6t \right)$ ]    |
| 4. $\frac{1}{(2s-1)^2}$ .         |  |  | [Ans. $\frac{1}{4} t e^{(1/2)t}$ ]                                 |

5.  $\frac{2s-3}{4s^2+4s+17}$ . [ Ans.  $\frac{1}{2} e^{-(1/2)t} (\cos 2t - \sin 2t)$  ]
6.  $\frac{s}{3s^2-2s-5}$ . [ Ans.  $\frac{1}{3} e^{(1/3)t} \left[ \cos h \frac{4}{3} t - \frac{1}{4} \sin h \frac{4}{3} t \right]$  ]
7.  $\frac{1}{\sqrt{2s+3}}$ . [ Ans.  $\frac{1}{\sqrt{2} \pi} e^{-3t/2} \cdot e^{-1/2}$  ]
8.  $\frac{s+1}{s^2+s+1}$ . [ Ans.  $\frac{e^{-(1/2)t}}{\sqrt{3}} \left[ \sqrt{3} \cos \frac{\sqrt{3}}{2} t + \sin \frac{\sqrt{3}}{2} t \right]$  ]
9.  $\frac{1}{(s+4)^{5/2}}$ . [ Ans.  $\frac{4t^{3/2} e^{-4t}}{3 \sqrt{\pi}}$  ]
10.  $\frac{7s+4}{4s^2+4s+9}$ . [ Ans.  $e^{-t/2} \left[ \frac{7}{4} \cos \sqrt{2} t + \frac{1}{8 \sqrt{2}} \sin \sqrt{2} t \right]$  ]

Find the inverse Laplace transforms of the following functions:

1.  $\frac{2s+1}{(s-1)(s-3)}$ . [ Ans.  $\frac{-3}{2} e^t + \frac{7}{2} e^{3t}$  ]
2.  $\frac{s-1}{s^2+s-6}$ . [ Ans.  $\frac{1}{5} e^{2t} + \frac{4}{5} e^{-3t}$  ]
3.  $\frac{1}{s^2-4s}$ . [ Ans.  $\frac{1}{4} (e^{4t} - 1)$  ]
4.  $\frac{s-4}{(2s+1)(3s-1)}$ . [ Ans.  $\frac{1}{5} [9 e^{-t/2} - 11 e^{t/3}]$  ]
5.  $\frac{5}{(s-1)(s-3)(s-5)}$ . [ Ans.  $\frac{1}{8} e^t - \frac{3}{4} e^{3t} + \frac{5}{8} e^{5t}$  ]
6.  $\frac{2s^2-4}{(s+1)(s-2)(s-3)}$ . [ Ans.  $\frac{-1}{6} e^{-t} - \frac{4}{3} e^{2t} + \frac{7}{2} e^{3t}$  ]
7.  $\frac{3s-2}{(s-2)(s+1)^2}$ . [ Ans.  $\frac{4}{9} e^{2t} - \frac{4}{9} e^{-t} + \frac{5t}{3} e^{-t}$  ]
8.  $\frac{s^2}{(s+2)(s^2-4)}$ . [ Ans.  $\frac{3}{4} e^{-2t} - t e^{-2t} + \frac{1}{4} e^{2t}$  ]
9.  $\frac{2s-1}{s^2(s-4)}$ . [ Ans.  $\frac{7}{16} e^{4t} - \frac{7}{16} + \frac{1}{4} e^t$  ]
10.  $\frac{3s+1}{(s-1)(s^2+1)}$ . [ Ans.  $2e^t - 2 \cos t + \sin t$  ]



11.  $\frac{2s-1}{(s+2)(s^2+4)}$        $\left[ \text{Ans. } \frac{-5}{8} e^{-2t} + \frac{5}{8} \cos 2t + \frac{3}{8} \sin 2t \right]$
12.  $\frac{5s+3}{(s-1)(s^2+2s+5)}$        $\left[ \text{Ans. } e^t - e^{-t} \left[ \cos 2t - \frac{3}{2} \sin 2t \right] \right]$
13.  $\frac{2s^2-1}{(s^2+1)(s^2+4)}$        $\left[ \text{Ans. } -\sin t + \frac{3}{2} \sin 2t \right]$
14.  $\frac{5s^2-15s-11}{(s+1)(s-2)^3}$        $\left[ \text{Ans. } -\frac{1}{3} e^{-t} - e^{2t} \left[ \frac{7}{2} t^2 - 4t - \frac{1}{3} \right] \right]$
15.  $\frac{s^2+2s+3}{(s^2+2s+2)(s^2+2s+5)}$        $\left[ \text{Ans. } \frac{1}{3} e^{-t} (\sin t + \sin 2t) \right]$
16.  $\frac{2s^2+5s-4}{s^3+s^2-2s}$        $\left[ \text{Ans. } 2 + e^t - e^{-2t} \right]$
17.  $\frac{1}{(s^2+1)(s^2+4s+8)}$        $\left[ \text{Ans. } -\frac{4}{65} \cos t + \frac{7}{65} \sin t + \frac{4}{65} e^{-2t} \cos 2t + \frac{1}{130} e^{-2t} \sin 2t \right]$

## 8.4

### INVERSE LAPLACE TRANSFORMS OF THE FUNCTIONS OF THE FORM $\frac{F(s)}{s}$

We have proved that

if  $L\{f(t)\} = F(s)$

then  $L\left\{\int_0^t f(t) dt\right\} = \frac{F(s)}{s}$

Hence,  $L^{-1}\left\{\frac{F(s)}{s}\right\} = \int_0^t f(t) dt \quad \dots(1)$

### WORKED OUT EXAMPLE

1. Evaluate

(i)  $L^{-1}\left\{\frac{1}{s(s+a)}\right\}$

(ii)  $L^{-1}\left\{\frac{1}{s(s^2+a^2)}\right\}$

(iii)  $L^{-1}\left\{\frac{s+2}{s^2(s+3)}\right\}$

(iv)  $L^{-1}\left\{\frac{1}{s^3(s^2+1)}\right\}$

(v)  $L^{-1}\left\{\frac{1}{s} \log\left(1 + \frac{1}{s^2}\right)\right\}$

**Solution**

(i) Consider  $L^{-1} \left\{ \frac{1}{s+a} \right\} = e^{-at}$

Using the equation (1), we get

$$L^{-1} \left\{ \frac{1}{s(s+a)} \right\} = \int_0^t e^{-at} dt = \left[ \frac{e^{-at}}{-a} \right]_0^t = \frac{1}{a} (1 - e^{-at}).$$

(ii) We have  $L^{-1} \left\{ \frac{1}{s^2 + a^2} \right\} = \frac{1}{a} \sin at$

∴ Using the equation (1), we get

$$\begin{aligned} L^{-1} \left\{ \frac{1}{s(s^2 + a^2)} \right\} &= \int_0^t \frac{1}{a} \sin at dt \\ &= \frac{1}{a} \left[ \frac{(-\cos at)}{a} \right]_0^t \\ &= \frac{1}{a^2} (1 - \cos at). \end{aligned}$$

(iii) By partial fractions

$$\begin{aligned} \frac{s+2}{s(s+3)} &= \frac{A}{s} + \frac{B}{s+3} \\ (s+2) &= A(s+3) + B(s) \end{aligned}$$

Put  $s = 0, A = \frac{2}{3}$

$s = -3, B = \frac{1}{3}$

$$\frac{s+2}{s(s+3)} = \frac{2}{3} + \frac{1}{3(s+3)}$$

$$\begin{aligned} L^{-1} \left[ \frac{s+2}{s(s+3)} \right] &= \frac{2}{3} L^{-1} \left\{ \frac{1}{s} \right\} + \frac{1}{3} L^{-1} \left\{ \frac{1}{s+3} \right\} \\ &= \frac{2}{3} \cdot 1 + \frac{1}{3} e^{-3t} \\ &= \frac{2}{3} + \frac{1}{3} e^{-3t} \end{aligned}$$

∴ From (1), we get

$$L^{-1} \left\{ \frac{1}{s} \cdot \frac{s+2}{s(s+3)} \right\} = \int_0^t \left( \frac{2}{3} + \frac{1}{3} e^{-3t} \right) dt$$

$$\begin{aligned}
 &= \left[ \frac{2}{3}t - \frac{1}{9}e^{-3t} \right]_0^t \\
 &= \frac{2}{3}t - \frac{1}{9}e^{-3t} + \frac{1}{9}
 \end{aligned}$$

$$(iv) \quad L^{-1} \left\{ \frac{1}{s^2 + 1} \right\} = \sin t$$

Hence by equation (1), we get

$$L^{-1} \left\{ \frac{1}{s(s^2 + 1)} \right\} = \int_0^t \sin t \, dt = 1 - \cos t$$

$$L^{-1} \left\{ \frac{1}{s^2(s^2 + 1)} \right\} = \int_0^t (1 - \cos t) \, dt = t - \sin t$$

and

$$L^{-1} \left\{ \frac{1}{s^3(s^2 + 1)} \right\} = \int_0^t (t - \sin t) \, dt$$

$$\begin{aligned}
 &= \left[ \frac{t^2}{2} + \cos t \right]_0^t \\
 &= \frac{t^2}{2} + \cos t - 1.
 \end{aligned}$$

$$(v) \quad \text{Let } L^{-1} \left\{ \log \left( 1 + \frac{1}{s^2} \right) \right\} = f(t)$$

$$\log \left( 1 + \frac{1}{s^2} \right) = L \{ f(t) \} = F(s)$$

$$\text{Now } \frac{d}{ds} \{ F(s) \} = \frac{d}{ds} \left[ \log(s^2 + 1) - \log s^2 \right]$$

$$= \frac{2s}{s^2 + 1} - \frac{2}{s}$$

$$= -2 \left[ \frac{1}{s} - \frac{s}{s^2 + 1} \right]$$

$$L^{-1} \left[ \frac{d}{ds} \{ F(s) \} \right] = -2 \left[ L^{-1} \left( \frac{1}{s} \right) - L^{-1} \left( \frac{s}{s^2 + 1} \right) \right]$$

$$= -2(1 - \cos t)$$

*i.e.,*

$$-t f(t) = -2(1 - \cos t)$$

or 
$$f(t) = \frac{2(1 - \cos t)}{t}$$

$$L^{-1} \left\{ \log \left( 1 + \frac{1}{s^2} \right) \right\} = \frac{2(1 - \cos t)}{t}$$

$$\therefore L^{-1} \left\{ \frac{1}{s} \log \left( 1 + \frac{1}{s^2} \right) \right\} = 2 \int_0^t \frac{1 - \cos t}{t} dt.$$

### EXERCISE 8.2

Find the inverse Laplace transforms of the following functions:

- |  |   |  |   |
|--|---|--|---|
| 1. $\log \frac{s-a}{s}$ .                                    | $\left[ \text{Ans. } \frac{1 - e^{at}}{t} \right]$        | 2. $\cot^{-1} \frac{s}{a}$ .                           | $\left[ \text{Ans. } \frac{\sin at}{t} \right]$   |
| 3. $\log \left( \frac{s^2 + a^2}{s^2 + b^2} \right)^{1/2}$ . | $\left[ \text{Ans. } \frac{\cos at - \cos bt}{t} \right]$ | 4. $\frac{a}{2} \log \left( \frac{s+a}{s-a} \right)$ . | $\left[ \text{Ans. } \frac{\sin h at}{t} \right]$ |

Find the inverse Laplace transforms of the following functions:

- |  |   |                                       |  |
|--|---|---------------------------------------|--|
| 1. $\frac{1}{s(s^2 - a^2)}$ .            | $\left[ \text{Ans. } \frac{1}{a^2} (\cosh at - 1) \right]$                        | 2. $\frac{1}{s^2(s-a)}$ .             | $\left[ \text{Ans. } \frac{1}{a^2} (e^{at} - at - 1) \right]$  |
| 3. $\frac{1}{s^2(s^2 + a^2)}$ .          | $\left[ \text{Ans. } \frac{-1}{a^2} \left( \frac{\sin at}{a} - t \right) \right]$ | 4. $\frac{1}{s(s+1)^3}$ .             | $\left[ \text{Ans. } e^{-t} - 1 - t - \frac{t^2}{2} \right]$   |
| 5. $\frac{1}{s^3(s^2 - 1)}$ .            | $\left[ \text{Ans. } \cosh t - \frac{t^2}{2} - 1 \right]$                         | 6. $\frac{1}{s} \log \frac{s-a}{s}$ . | $\left[ \text{Ans. } \int_0^t \frac{1 - e^{at}}{t} dt \right]$ |
| 7. $\frac{1}{s} \cot^{-1} \frac{s}{a}$ . | $\left[ \text{Ans. } \int_0^t \frac{\sin t}{t} dt \right]$                        |                                       |  |

Evaluate:

- |  |  |
|--|--|
| 1. $L^{-1} \left\{ \frac{s^2 - a^2}{(s^2 + a^2)^2} \right\}$ given that $L^{-1} \left\{ \frac{s}{s^2 + a^2} \right\} = \cos at$ .  | $\left[ \text{Ans. } t \cos at \right]$                    |
| 2. $L^{-1} \left\{ \frac{s^2 + a^2}{(s^2 - a^2)^2} \right\}$ given that $L^{-1} \left\{ \frac{s}{s^2 - a^2} \right\} = \cosh at$ . | $\left[ \text{Ans. } t \cosh at \right]$                   |
| 3. $L^{-1} \left\{ \frac{s+2}{(s^2 + 4s + 5)^2} \right\}$ given that $L^{-1} \left\{ \frac{1}{s^2 + 1} \right\} = \sin t$ .        | $\left[ \text{Ans. } \frac{1}{2} t e^{-2t} \sin t \right]$ |

## 8.5 CONVOLUTION THEOREM

If  $L^{-1}\{F(s)\} = f(t)$  and  $L^{-1}\{G(s)\} = g(t)$

then  $L^{-1}\{F(s) G(s)\} = \int_0^t f(u) g(t-u) du$  ... (1)

**Proof.** Since  $L^{-1}\{F(s)\} = f(t)$  and  $L^{-1}\{G(s)\} = g(t)$

we have  $F(s) = L\{f(t)\} = \int_0^\infty e^{-st} f(t) dt$

and  $G(s) = L\{g(t)\} = \int_0^\infty e^{-st} g(t) dt$

To prove (1), it is sufficient to prove that

$$L\left\{\int_0^t f(u) g(t-u) du\right\} = F(s) G(s) \quad \dots(2)$$

Consider

$$\begin{aligned} L\left\{\int_0^t f(u) g(t-u) du\right\} &= \int_0^\infty e^{-st} \left\{\int_0^t f(u) g(t-u) du\right\} dt \\ &= \int_{t=0}^\infty \int_{u=0}^t e^{-st} f(u) g(t-u) du dt \quad \dots(3) \end{aligned}$$

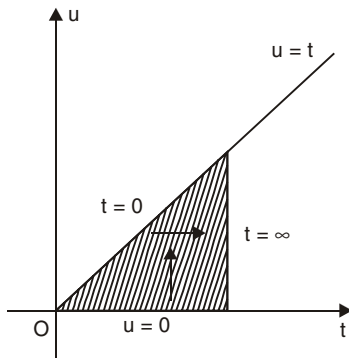

Fig. 8.1

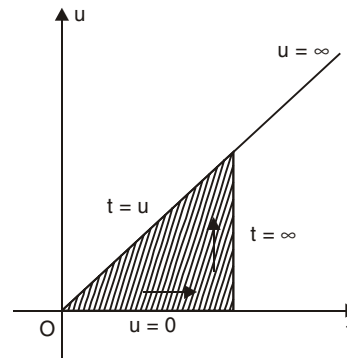

Fig. 8.2

The domain of integration for the above double integral is from  $u = 0$  to  $u = t$  and  $t = 0$  to  $t = \infty$  which is as shown in Fig. 8.1.

The double integral given in the R.H.S. of equation (3) indicates that we integrate first parallel to  $u$ -axis and then parallel to  $t$ -axis.

We shall now change the order of integration parallel to  $t$ -axis the limits being  $t = u$  to  $t = \infty$  and parallel to  $u$ -axis the limits being  $u = 0$  to  $u = \infty$ .

$\therefore$  From equation (3), we get

$$\begin{aligned} L\left\{\int_0^t f(u) g(t-u) du\right\} &= \int_0^\infty f(u) \left\{\int_u^\infty e^{-st} g(t-u) dt\right\} du \\ &= \int_0^\infty f(u) e^{-su} \left\{\int_u^\infty e^{-s(t-u)} g(t-u) dt\right\} du \end{aligned}$$

Substitute  $t - u = v$  so that  $dt = dv$

when  $t = u$ ,  $v = 0$ , and when  $t = \infty$ ,  $v = \infty$

$$\begin{aligned} L \left\{ \int_0^t f(u) g(t-u) du \right\} &= \int_0^\infty f(u) e^{-su} \left\{ \int_0^\infty e^{-sv} g(v) dv \right\} du \\ &= \int_0^\infty f(u) e^{-su} G(s) du \\ &= G(s) \int_0^\infty e^{-su} f(u) du \\ &= G(s) \cdot F(s) \end{aligned}$$

$$\therefore L^{-1} \{F(s) G(s)\} = \int_0^t f(u) g(t-u) du$$

This completes the proof of the theorem.

### WORKED OUT EXAMPLES

1. Using Convolution theorem find the inverse Laplace transforms of the following functions:

(i)  $\frac{1}{s^2 (s+1)^2}$

(ii)  $\frac{1}{(s+1)(s^2+1)}$

(iii)  $\frac{s}{(s+1)^2 (s^2+1)}$

(iv)  $\frac{s}{(s^2+a^2)^2}$

(v)  $\frac{s}{(s^2+4)^2}$

(vi)  $\frac{s^2}{(s^2+a^2)^2}$

(vii)  $\frac{s^2}{(s^2+a^2)(s^2+b^2)}$

**Solution**

(i) Let  $F(s) = \frac{1}{(s+1)^2}$ ,  $G(s) = \frac{1}{s^2}$

Then  $L^{-1} \{F(s)\} = L^{-1} \left\{ \frac{1}{(s+1)^2} \right\} = t e^{-t} = f(t)$  (say)

$$L^{-1} \{G(s)\} = L^{-1} \left\{ \frac{1}{s^2} \right\} = t = g(t) \text{ say}$$

Then by Convolution theorem, we have

$$\begin{aligned} L^{-1} \{F(s) G(s)\} &= \int_0^t f(u) g(t-u) du \\ L^{-1} \left\{ \frac{1}{s^2 (s+1)^2} \right\} &= \int_0^t u e^{-u} (t-u) du \\ &= \int_0^t (ut - u^2) e^{-u} du \end{aligned}$$

By integration by parts

$$\begin{aligned}
 &= \left[ (ut - u^2)(-e^{-u}) - (t - 2u)(e^{-u}) + (-2)(-e^{-u}) \right]_0^t \\
 &= t e^{-t} + 2 e^{-t} + t - 2
 \end{aligned}$$

**Verification:**

$$\begin{aligned}
 L \{t e^{-t} + 2 e^{-t} + t - 2\} &= L \{t e^{-t}\} + 2 L \{e^{-t}\} + L \{t\} - 2 L \{1\} \\
 &= \frac{1}{(s+1)^2} + \frac{2}{s+1} + \frac{1}{s^2} - \frac{2}{s} \\
 &= \frac{s^2 + 2s^2(s+1) + (s+1)^2 - 2s(s+1)^2}{s^2(s+1)^2} \\
 &= \frac{1}{s^2(s+1)^2}.
 \end{aligned}$$

(ii) Here  $F(s) G(s) = \frac{1}{(s+1)(s^2+1)}$

Let  $F(s) = \frac{1}{s^2+1}$ ,  $G(s) = \frac{1}{s+1}$

$$L^{-1} \{F(s)\} = L^{-1} \left\{ \frac{1}{s^2+1} \right\} = \sin t = f(t)$$

$$L^{-1} \{G(s)\} = L^{-1} \left\{ \frac{1}{s+1} \right\} = e^{-t} = g(t)$$

Let

$$t = u,$$

$$f(u) = \sin u \quad \text{and} \quad g(u) = e^{-u}$$

Then by Convolution theorem, we obtain

$$\begin{aligned}
 L^{-1} \left\{ \frac{1}{(s+1)(s^2+1)} \right\} &= L^{-1} \{F(s) G(s)\} = \int_0^t f(u) g(t-u) du \\
 &= \int_0^t \sin u \cdot e^{-(t-u)} du \\
 &= e^{-t} \int_0^t e^u \sin u du \\
 &= e^{-t} \left[ \frac{e^u}{2} (\sin u - \cos u) \right]_0^t
 \end{aligned}$$

Using the formula  $\int e^{ax} \sin bx dx = \frac{e^{ax}}{a^2+b^2} (a \sin bx - b \cos bx) + c$

$$= \frac{1}{2} (\sin t - \cos t) + \frac{1}{2} e^{-t}.$$

(iii) Here  $F(s) G(s) = \frac{s}{(s+1)^2 (s^2+1)} = \frac{s}{s^2+1} \cdot \frac{1}{(s+1)^2}$

Let  $F(s) = \frac{s}{s^2+1}, \quad G(s) = \frac{1}{(s+1)^2}$

$$L^{-1}\{F(s)\} = L^{-1}\left\{\frac{s}{s^2+1}\right\} = \cos t = f(t)$$

$$L^{-1}\{G(s)\} = L^{-1}\left\{\frac{1}{(s+1)^2}\right\} = t e^{-t} = g(t)$$

$$t = u, \quad g(u) = u e^{-u}, \quad f(u) = \cos u$$

Hence by Convolution theorem,

$$\begin{aligned} L^{-1}\left\{\frac{s}{(s^2+1)(s+1)^2}\right\} &= \int_0^t f(u) g(t-u) du = L^{-1}\{F(s) G(s)\} \\ &= \int_0^t \cos u (t-u) e^{-(t-u)} du \\ &= e^{-t} \int_0^t (t-u) \cos u e^u du \end{aligned}$$

Since,  $\int e^u \cos u du = \frac{e^u}{2} (\cos u + \sin u)$

Integrating by parts, we get

$$\begin{aligned} &= e^{-t} \left[ \left\{ (t-u) \frac{e^u}{2} (\sin u + \cos u) \right\}_0^t - \int_0^t \frac{e^u}{2} (\sin u + \cos u) (-1) du \right] \\ &= e^{-t} \left[ 0 - \frac{1}{2} t + \frac{1}{2} \int_0^t e^u (\sin u + \cos u) du \right] \\ &= e^{-t} \left[ -\frac{1}{2} t + \frac{1}{2} e^u \sin u \right]_0^t \\ &= e^{-t} \left[ -\frac{1}{2} t + \frac{1}{2} e^t \sin t \right] \\ &= \frac{1}{2} (t e^{-t} + \sin t). \end{aligned}$$

(iv) Here  $F(s) G(s) = \frac{s}{(s^2+a^2)^2} + \frac{s}{(s^2+a^2)} \cdot \frac{1}{(s^2+a^2)}$

Let  $F(s) = \frac{s}{s^2+a^2}, \quad G(s) = \frac{1}{s^2+a^2}$



Then 
$$L^{-1} \{F(s)\} = L^{-1} \left\{ \frac{s}{s^2 + a^2} \right\} = \cos at = f(t)$$

$$L^{-1} \{G(s)\} = L^{-1} \left\{ \frac{1}{s^2 + a^2} \right\} = \frac{1}{a} \sin at = g(t)$$

$$t = u, \quad f(u) = \cos au, \quad g(u) = \frac{1}{a} \sin au.$$

Using Convolution theorem, we have

$$L^{-1} \{F(s) G(s)\} = \int_0^t f(u) g(t-u) du$$

*i.e.*, 
$$L^{-1} \left\{ \frac{s}{(s^2 + a^2)^2} \right\} = \int_0^t \cos au \frac{1}{a} \sin a(t-u) du$$

$$= \frac{1}{a} \int_0^t \cos au \sin (at - au) du$$

$$= \frac{1}{2a} \int_0^t [\sin at + \sin (at - 2au)] du$$

$$= \frac{1}{2a} \left[ u \sin at - \frac{1}{-2a} \cos (at - 2au) \right]_0^t$$

$$= \frac{1}{2a} t \sin at.$$

(v) Substituting  $a = 2$ , in (iv) we get the required inverse Laplace transform.

(vi) Here, 
$$F(s) \cdot G(s) = \frac{s^2}{(s^2 + a^2)^2} = \frac{s}{s^2 + a^2} \cdot \frac{s}{s^2 + a^2}$$

Let 
$$F(s) = \frac{s}{s^2 + a^2} \quad \text{and} \quad G(s) = \frac{s}{s^2 + a^2}$$

Hence, 
$$L^{-1} \{F(s)\} = L^{-1} \left\{ \frac{s}{s^2 + a^2} \right\} = \cos at = f(t)$$

$$L^{-1} \{G(s)\} = L^{-1} \left\{ \frac{s}{s^2 + a^2} \right\} = \cos at = g(t)$$

*i.e.*, 
$$f(t) = g(t) = \cos at$$

$$f(u) = g(u) = \cos au$$

Using Convolution theorem, we have

$$L^{-1} \{F(s) G(s)\} = \int_0^t \cos au \cdot \cos a(t-u) du$$

*i.e.*, 
$$L^{-1} \frac{s^2}{(s^2 + a^2)^2} = \int_0^t \cos (at - au) \cos au du$$

$$\begin{aligned}
 &= \frac{1}{2} \int_0^t [\cos at + \cos (at - 2au)] du \\
 &= \frac{1}{2} \left[ u \cos at - \frac{1}{2a} \sin (at - 2au) \right]_0^t \\
 &= \frac{1}{2} \left[ t \cos at + \frac{1}{a} \sin at \right].
 \end{aligned}$$

(vii) Let  $F(s) = \frac{s}{s^2 + a^2}$  and  $G(s) = \frac{s}{s^2 + b^2}$

Then  $L^{-1} F(s) = L^{-1} \left\{ \frac{s}{s^2 + a^2} \right\} = \cos at = f(t)$

and  $L^{-1} G(s) = L^{-1} \left\{ \frac{s}{s^2 + b^2} \right\} = \cos bt = g(t)$

Therefore using Convolution theorem, we get

$$L^{-1} \{F(s) G(s)\} = \int_0^t f(u) g(t-u) du$$

i.e., 
$$\begin{aligned}
 L^{-1} \left\{ \frac{s^2}{(s^2 + a^2)(s^2 + b^2)} \right\} &= \int_0^t \cos au \cos b(t-u) du \\
 &= \frac{1}{2} \int_0^t \{ \cos [(a-b)u + bt] + \cos [(a+b)u - bt] \} du \\
 &= \frac{1}{2} \left\{ \frac{\sin (a-b)u + bt}{a-b} + \frac{\sin [(a+b)u - bt]}{a+b} \right\}_0^t \\
 &= \frac{a \sin at - b \sin bt}{a^2 - b^2}, \quad a \neq b.
 \end{aligned}$$

2. Using Convolution theorem, evaluate  $L^{-1} \left\{ \frac{s}{(s^2 + 4)^3} \right\}$ .

**Solution**

Let  $F(s) = \frac{1}{s^2 + 4}$  and  $G(s) = \frac{s}{(s^2 + 4)^2}$

Now,  $L^{-1} \{F(s)\} = L^{-1} \left\{ \frac{1}{s^2 + 4} \right\} = \frac{1}{2} \sin 2t$

Hence  $L^{-1} \left\{ \frac{-2s}{(s^2 + 4)^2} \right\} = -t \cdot \frac{1}{2} \sin 2t$

Since,  $L^{-1} \{F'(s)\} = -t f(t)$

$$\text{i.e., } L^{-1} \left\{ \frac{s}{(s^2 + 4)^2} \right\} = \frac{1}{4} t \sin 2t$$

$$\text{i.e., } \{G(s)\} = \frac{1}{4} t \sin 2t$$

Therefore using Convolution theorem, we have

$$L^{-1} \{F(s) G(s)\} = \int_0^t f(t-u) g(u) du$$

$$\begin{aligned} \text{i.e., } L^{-1} \left\{ \frac{s}{(s^2 + 4)^3} \right\} &= \int_0^t \frac{1}{2} \sin 2(t-u) \cdot \frac{1}{4} u \sin 2u du \\ &= \frac{1}{8} \int_0^t u \sin(2t-2u) \sin 2u du \\ &= \frac{1}{16} \int_0^t u [\cos(2t-4u) - \cos 2t] du \\ &= \frac{1}{16} \left[ \int_0^t u \cos(2t-4u) du - \cos 2t \int_0^t u du \right] \\ &= \frac{1}{64} (t \sin 2t - 2t^2 \cos 2t). \end{aligned}$$

3. Find  $f(t)$  in the following equations:

$$(i) f(t) = t + \int_0^t e^{-u} f(t-u) du \quad (ii) f(t) = t + 2 \int_0^t \cos(t-u) f(u) du$$

$$(iii) f'(t) = \int_0^t f(u) \cos(t-u) du, \text{ if } f(0) = 1.$$

**Solution**

(i) Taking Laplace transforms on both sides of the given equation, we get

$$L\{f(t)\} = L\{t\} + L\left\{ \int_0^t e^{-u} f(t-u) du \right\}$$

Using Convolution theorem, we have

$$L\{f(t)\} = \frac{1}{s^2} + L(e^{-t}) L\{f(t)\}$$

$$\text{i.e., } F(s) = \frac{1}{s^2} + \frac{1}{s+1} F(s)$$

$$\text{i.e., } F(s) \left[ 1 - \frac{1}{s+1} \right] = \frac{1}{s^2}$$

$$F(s) = \frac{s+1}{s^3}$$

$$\text{i.e., } L\{f(t)\} = \frac{1}{s^2} + \frac{1}{s^3}$$

Hence, 
$$f(t) = L^{-1}\left(\frac{1}{s^2}\right) + L^{-1}\left(\frac{1}{s^3}\right)$$

$$f(t) = t + \frac{t^2}{2}.$$

(ii) Taking Laplace transforms on both sides, we get

$$L\{f(t)\} = L(t) + 2L\left\{\int_0^t \cos(t-u)f(u)du\right\}$$

Using Convolution theorem, we have

$$= \frac{1}{s^2} + 2L(\cos t)L\{f(t)\}$$

i.e., 
$$F(s) = \frac{1}{s^2} + \frac{2s}{s^2+1}F(s)$$

i.e., 
$$L\{f(t)\} = F(s) = \frac{s^2+1}{s^2(s-1)^2}$$

$$\frac{s^2+1}{s^2(s-1)^2} = \frac{2}{s} + \frac{1}{s^2} - \frac{2}{s-1} + \frac{2}{(s-1)^2}$$

$\therefore$  
$$f(t) = L^{-1}\left\{\frac{2}{s} + \frac{1}{s^2} - \frac{2}{s-1} + \frac{2}{(s-1)^2}\right\}$$

$$= 2 + t - 2e^t + 2te^t$$

$$f(t) = 2 + t + 2(t-1)e^t.$$

(iii) From the given equation, we have

$$L\{f'(t)\} = L\left\{\int_0^t f(u)\cos(t-u)du\right\}$$

By using Convolution theorem, we get

$$sL\{f(t)\} - f(0) = L\{f(t)\} \cdot L(\cos t)$$

$$sF(s) - 1 = F(s) \cdot \frac{s}{s^2+1}$$

$$F(s)\left[s - \frac{s}{s^2+1}\right] = 1$$

$$F(s) = \frac{s^2+1}{s^3}$$

i.e., 
$$L\{f'(t)\} = F(s) = \frac{s^2+1}{s^3} = \frac{1}{s} + \frac{1}{s^3}$$

$$f(t) = L^{-1}\left[\frac{1}{s} + \frac{1}{s^3}\right]$$

$$f(t) = 1 + \frac{t^2}{2}.$$

### EXERCISE 8.3

Verify Convolution theorem:

$$L\{f(t)\} L\{g(t)\} = L\left\{\int_0^t f(u)g(t-u)du\right\}$$

for the following functions:

1.  $f(t) = 1, g(t) = \cos t.$

2.  $f(t) = t, g(t) = e^t.$

3.  $f(t) = \sin t, g(t) = e^{-t}.$

4.  $f(t) = t, g(t) = te^{-t}.$

5.  $f(t) = \sin 2t, g(t) = \cos 2t.$

Using Convolution theorem find the inverse Laplace transforms of the following functions:

1.  $\frac{1}{(s-4)(s+5)}.$  [Ans.  $\frac{1}{9}(e^{4t} - e^{-5t})$ ]

2.  $\frac{1}{s^2(s-2)}.$  [Ans.  $\frac{1}{4}e^{2t} - \frac{1}{2}t - \frac{1}{4}$ ]

3.  $\frac{1}{s^2(s^2+9)}.$  [Ans.  $\frac{1}{9}\left(t - \frac{1}{3}\cos 3t\right)$ ]

4.  $\frac{1}{s^2(s+2)^2}.$  [Ans.  $\frac{1}{t}(1+t)e^{-2t} + \frac{1}{4}(t-1)$ ]

5.  $\frac{s}{(s^2+4)(s^2+9)}.$  [Ans.  $\frac{1}{5}(\cos 2t - \cos 3t)$ ]

6.  $\frac{1}{(s-2)(s+2)^2}.$  [Ans.  $\frac{1}{16}[e^{2t} - (4t+1)e^{-2t}]$ ]

7.  $\frac{1}{(s^2+4)(s+1)^2}.$  [Ans.  $\frac{e^{-t}}{50}[10e^{-t} - (3\sin 2t + 4\cos 2t)]$ ]

8.  $\frac{1}{s^3(s^2+1)}.$  [Ans.  $\frac{1}{2}t^2 + \cos t - 1$ ]

9.  $\frac{s}{(s^2+a^2)(s^2+b^2)}.$  [Ans.  $\frac{\cos bt - \cos at}{a^2 - b^2}$ ]

10.  $\frac{1}{(s^2+1)^3}.$  [Ans.  $\frac{1}{8}[(3-t^2)\sin t - 3t\cos t]$ ]

11.  $\frac{4s+5}{(s-1)^2(s+2)}.$  [Ans.  $3te^t + \frac{1}{3}e^t - \frac{1}{3}e^{2t}$ ]

**Find  $f(t)$  in the following integral equations:**

$$1. f(t) = t + \frac{1}{6} \int_0^t (t-u)^3 f(u) du. \quad \left[ \text{Ans. } f(t) = \frac{1}{2} (\sin t + \sin ht) \right]$$

$$2. f(t) = \sin t + 5 \int_0^t f(u) \sin(t-u) du. \quad \left[ \text{Ans. } \frac{1}{2} \sin ht \right]$$

$$3. f(t) = t^2 - \int_0^t e^u f(t-u) du. \quad \left[ \text{Ans. } t^2 - \frac{1}{3} t^3 \right]$$

$$4. \int_0^t \frac{f(u)}{(t-u)^{1/3}} du = t(1+t). \quad \left[ \text{Ans. } \frac{3\sqrt{3}}{4\pi} t^{1/3} (3t+2) \right]$$

$$5. f'(t) = t + \int_0^t f(t-u) \cos u du, \text{ if } f(0) = 4. \quad \left[ \text{Ans. } f(t) = 4 + \frac{5}{2} t^2 + \frac{1}{24} t^4 \right]$$

$$6. f'(t) + 5 \int_0^t \cos 2(t-u) f(u) du = 10, \text{ if } f(0) = 2. \quad \left[ \text{Ans. } f(t) = \frac{1}{27} (24 + 120t + 30 \cos t + 50 \sin 3t) \right]$$

### 8.6 LAPLACE TRANSFORMS OF THE DERIVATIVES

If the Laplace transform of  $f(t)$  is known then by using the following results we can find the Laplace transforms of the derivatives  $f'(t)$ ,  $f''(t)$ , ...  $f^n(t)$  and  $\int_0^t f(t) dt$ .

**Laplace transforms of the derivatives:** *Functions of exponential order.*

A continuous function  $f(t)$ ,  $t > 0$  is said to be of exponential order

if 
$$\lim_{t \rightarrow \infty} e^{-st} f(t) = 0$$

**Theorem:** If  $f(t)$  is of exponential order and  $f'(t)$  is continuous then

$$L \{ f'(t) \} = s L \{ f(t) \} - f(0) \quad \dots(1)$$

**Proof:** By the definition of Laplace transform, we have

$$L f'(t) = \int_0^\infty e^{-st} f'(t) dt$$

Apply integration by parts

$$\begin{aligned} &= \left[ e^{-st} f(t) \right]_0^\infty - \int_0^\infty f(t) e^{-st} (-s) dt \\ &= 0 - f(0) + s \int_0^\infty e^{-st} f(t) dt \\ &= -f(0) + s \int_0^\infty e^{-st} f(t) dt \\ &= -f(0) + s L \{ f(t) \} \end{aligned}$$

$$L \{ f' (t) \} = sL \{ f(t) \} - f(0)$$

Laplace transform of  $f'' (t)$

$$L \{ f'' (t) \} = s^2 L \{ f(t) \} - s f(0) - f' (0) \quad \dots(2)$$

Let

$$f' (t) = g (t) \quad \text{so that} \quad f'' (t) = g' (t)$$

Consider

$$\begin{aligned} L f'' (t) &= L \{ g' (t) \} \\ &= sL \{ g (t) \} - g (0), \text{ using (2)} \\ &= sL \{ f' (t) \} - f' (0) \\ &= s [sL \{ f(t) \} - f(0)] - f' (0) \end{aligned}$$

$$L \{ f'' (t) \} = s^2 L \{ f(t) \} - s f(0) - f' (0)$$

Similarly,

$$L \{ f''' (t) \} = s^3 L \{ f(t) \} - s^2 f(0) - s f' (0) - f'' (0) \quad \dots(3)$$

$$L \{ f^n (t) \} = s^n L \{ f(t) \} - s^{n-1} f(0) - s^{n-2} f' (0) \dots f^{n-1} (0) \quad \dots(4)$$

If  $f(t) = y$  then (4) can be written in the form

$$L (y^n) = s^n L (y) - s^{n-1} y (0) - s^{n-2} y' (0) - \dots - y^{n-1} (0)$$

where  $y', y'', \dots, y^{(n)}$  denoted the successive derivatives.

## 8.7 SOLUTION OF LINEAR DIFFERENTIAL EQUATIONS

One of the important applications of Laplace transforms is to solve linear differential equations with constant coefficients with initial conditions. For example, consider a second order linear differential equation

$$\frac{d^2 y}{dx^2} + a_0 \frac{dy}{dx} + a_1 y = f(t)$$

$$\text{i.e.,} \quad y'' + a_0 y' + a_1 y = f(t)$$

where  $a_0, a_1$  are constants with initial conditions  $y(0) = A$  and  $y'(0) = B$ .

Taking Laplace transforms on both sides of the above equation and using the formulae on Laplace transforms of the derivatives  $y'$  and  $y''$ .

We recall the formulae for immediate reference.

$$L (y') = s L (y) - y (0)$$

$$L (y'') = s^2 L (y) - s y (0) - y' (0)$$

$$L (y''') = s^3 L (y) - s^2 y (0) - s y' (0) - y'' (0)$$

and so on.

### WORKED OUT EXAMPLES

1. Solve using Laplace transforms.

$$\frac{d^2 y}{dt^2} - 3 \frac{dy}{dt} + 2y = e^{3t}$$

given that  $y(0) = 0$  and  $y'(0) = 0$ .

**Solution.** Given equation is  $y'' - 3y' + 2y = e^{3t}$

Taking Laplace transforms on both sides, we get

$$L(y'') - 3L(y') + 2L(y) = L(e^{3t})$$

$$\text{i.e., } s^2 L(y) - s y(0) - y'(0) - 3[sL(y) - y(0)] + 2L(y) = \frac{1}{s-3}$$

where  $y(0) = 0$  and  $y'(0) = 0$

$$\text{i.e., } (s^2 - 3s + 2)L(y) = \frac{1}{s-3} \text{ using the initial conditions}$$

$$\text{i.e., } L(y) = \frac{1}{(s^2 - 3s + 2)(s-3)}$$

$$= \frac{1}{(s-1)(s-2)(s-3)}$$

$$\begin{aligned} \therefore y &= L^{-1} \left[ \frac{1}{(s-1)(s-2)(s-3)} \right] \\ &= L^{-1} \left[ \frac{\frac{1}{2}}{s-1} - \frac{1}{s-2} + \frac{\frac{1}{2}}{s-3} \right] \text{ using partial fractions,} \\ &= \frac{1}{2} L^{-1} \left\{ \frac{1}{s-1} \right\} - L^{-1} \left\{ \frac{1}{s-2} \right\} + \frac{1}{2} L^{-1} \left\{ \frac{1}{s-3} \right\} \\ y &= \frac{1}{2} e^t - e^{2t} + \frac{1}{2} e^{3t} \end{aligned}$$

This is the required solution.

**2. Solve using Laplace transforms**

$$\frac{d^2 y}{dt^2} - 3 \frac{dy}{dt} + 2y = 4e^{2t}$$

given that  $y(0) = -3$  and  $y'(0) = 5$ .

**Solution.** Given equation is

$$y'' - 3y' + 2y = 4e^{2t}$$

Taking Laplace transforms on both sides, we get

$$L(y'') - 3L(y') + 2L(y) = 4L(e^{2t})$$

$$s^2 L(y) - s y(0) - y'(0) - 3[sL(y) - y(0)] + 2L(y) = \frac{4}{s-2}$$

where  $y(0) = -3$  and  $y'(0) = 5$

$$\text{i.e., } s^2 L(y) + 3s - 5 - 3[sL(y) - 3] + 2L(y) = \frac{4}{s-2}$$



$$\begin{aligned}
 \text{i.e.,} \quad (s^2 - 3s + 2)L(y) &= \frac{4}{s-2} - 3s + 14 \\
 &= \frac{4 - 3s^2 + 14s + 6s - 28}{s-2} \\
 &= \frac{-3s^2 + 20s - 24}{s-2}
 \end{aligned}$$

$$\therefore L(y) = \frac{-3s^2 + 20s - 24}{(s-2)(s^2 - 3s + 2)}$$

By using partial fraction

$$\begin{aligned}
 &= \frac{-3s^2 + 20s - 24}{(s-1)(s-2)^2} \\
 L(y) &= \frac{-7}{s-1} + \frac{4}{s-2} + \frac{4}{(s-2)^2}
 \end{aligned}$$

Hence,

$$\begin{aligned}
 y &= L^{-1} \left[ \frac{-7}{s-1} + \frac{4}{s-2} + \frac{4}{(s-2)^2} \right] \\
 &= -7 L^{-1} \left( \frac{1}{s-1} \right) + 4 L^{-1} \left[ \frac{1}{s-2} \right] + 4 L^{-1} \left[ \frac{1}{(s-2)^2} \right] \\
 y &= -7e^t + 4e^{2t} + 4e^{2t} \cdot t
 \end{aligned}$$

This is the required solution.

3. Solve using Laplace transforms,  $\frac{d^2 y}{dt^2} + y = t$

Given  $y(0) = 1$  and  $y'(0) = -2$ .

**Solution.** Given equation is  $y'' + y = t$ .

Taking Laplace transforms on both sides

$$L(y'') + L(y) = L(t)$$

$$\text{i.e., } s^2 L(y) - s y(0) - y'(0) + L(y) = \frac{1}{s^2}$$

where  $y(0) = 1$  and  $y'(0) = -2$

$$\text{i.e., } s^2 L(y) - s + 2 + L(y) = \frac{1}{s^2}$$

$$L(y)(s^2 + 1) - s + 2 = \frac{1}{s^2}$$

$$L(y)(s^2 + 1) = \frac{1}{s^2} + s - 2$$

$$L(y) = \frac{1}{s^2(s^2+1)} + \frac{s-2}{s^2+1}$$

*i.e.,*

$$\begin{aligned} L(y) &= \frac{1}{s^2} - \frac{1}{s^2+1} + \frac{s}{s^2+1} - \frac{2}{s^2+1} \\ &= \frac{1}{s^2} + \frac{s}{s^2+1} - \frac{3}{s^2+1} \end{aligned}$$

Hence,

$$\begin{aligned} y &= L^{-1}\left\{\frac{1}{s^2}\right\} + L^{-1}\left\{\frac{s}{s^2+1}\right\} - 3L^{-1}\left\{\frac{1}{s^2+1}\right\} \\ y &= t + \cos t - 3 \sin t \end{aligned}$$

This is the required solution.

4. Solve using Laplace transforms  $\frac{d^2y}{dt^2} - 5\frac{dy}{dt} + 6y = \sin t$ ,

given  $y(0) = \frac{1}{10}$  and  $y'(0) = \frac{21}{10}$ .

**Solution.** Given equation is

$$y'' - 5y' + 6y = \sin t.$$

Taking Laplace transforms on both sides, we get

$$L(y'') - 5L(y') + 6L(y) = L(\sin t)$$

*i.e.,*  $s^2L(y) - sy(0) - y'(0) - 5[sL(y) - y(0)] + 6L(y) = \frac{1}{s^2+1}$

where  $y(0) = \frac{1}{10}$  and  $y'(0) = \frac{21}{10}$

*i.e.,*  $s^2L(y) - \frac{s}{10} - \frac{21}{10} - 5\left[sL(y) - \frac{1}{10}\right] + 6L(y) = \frac{1}{s^2+1}$

$$(s^2 - 5s + 6)L(y) = \frac{1}{s^2+1} + \frac{1}{10}(s+16)$$

$$L(y) = \frac{1}{(s^2+1)(s^2-5s+6)} + \frac{1}{10} \frac{s+16}{(s^2-5s+6)}$$

*i.e.,*

$$L(y) = \frac{1}{(s^2+1)(s-3)(s-2)} + \frac{1}{10} \cdot \frac{s+16}{(s-2)(s-3)}$$

$$= \frac{1}{s^2+1} + \frac{-1}{s-2} + \frac{1}{s-3} + \frac{1}{10} \left[ \frac{-18}{s-2} + \frac{19}{s-3} \right]$$

By using partial fractions

$$= \frac{-2}{s-2} + \frac{2}{s-3} + \frac{1}{10} \left[ \frac{s}{s^2+1} + \frac{1}{s^2+1} \right]$$

$$\begin{aligned} \text{Therefore, } y &= L^{-1} \left\{ \frac{-2}{s-2} + \frac{2}{s-3} + \frac{1}{10} \left[ \frac{s}{s^2+1} + \frac{1}{s^2+1} \right] \right\} \\ y &= -2 L^{-1} \left\{ \frac{1}{s-2} \right\} + 2 L^{-1} \left\{ \frac{1}{s-3} \right\} + \frac{1}{10} \left[ L^{-1} \left\{ \frac{s}{s^2+1} \right\} + L^{-1} \left\{ \frac{1}{s^2+1} \right\} \right] \\ &= -2e^{2t} + 2e^{3t} + \frac{1}{10} (\cos t + \sin t) \end{aligned}$$

which is the required solution.

**5. Solve using Laplace transforms**

$$y'' + 2y' + 5y = 8 \sin t + 4 \cos t$$

given that  $y(0) = 1$  and  $y(\pi) = e^{-\pi}$ .

**Solution.** Given equation is

$$y'' + 2y' + 5y = 8 \sin t + 4 \cos t$$

Taking the Laplace transforms on both sides, we get

$$L(y'') + 2L(y') + 5L(y) = 8L(\sin t) + 4L(\cos t)$$

$$\text{i.e., } s^2 L(y) - s y(0) - y'(0) + 2[sL(y) - y(0)] + 5L(y) = \frac{8}{s^2+1} + \frac{4s}{s^2+1}$$

Since  $y(0) = 1$  and assuming  $y'(0) = A$ , we get

$$(s^2 + 2s + 5)L(y) - s - A - 2 = \frac{4(s+2)}{s^2+1}$$

$$(s^2 + 2s + 5)L(y) = \frac{4(s+2)}{s^2+1} + s + A + 2$$

$$\begin{aligned} \therefore L(y) &= \frac{4(s+2)}{(s^2+1)(s^2+2s+5)} + \frac{s+A+2}{s^2+2s+5} \\ &= 2 \left[ \frac{1}{s^2+1} - \frac{1}{s^2+2s+5} \right] + \frac{(s+1)+A+1}{s^2+2s+5} \\ &= 2 \left[ \frac{1}{s^2+1} - \frac{1}{(s+1)^2+2^2} \right] + \frac{(s+1)+A+1}{(s+1)^2+2^2} \end{aligned}$$

Therefore,

$$\begin{aligned} y &= 2 \left[ L^{-1} \left\{ \frac{1}{s^2+1} \right\} - L^{-1} \left\{ \frac{1}{(s+1)^2+2^2} \right\} \right] \\ &\quad + L^{-1} \left\{ \frac{s+1}{(s+1)^2+2^2} \right\} + L^{-1} \left\{ \frac{A+1}{(s+1)^2+2^2} \right\} \\ &= 2 \left[ \sin t - \frac{1}{2} e^{-t} \sin t \right] + e^{-t} \cos 2t + (A+1) e^{-t} \frac{\sin t}{2} \end{aligned}$$

$$y = e^{-t} \cos 2t + 2 \sin t + \frac{1}{2} (A - 1) e^{-t} \sin 2t$$

Since  $y(\pi) = e^{-\pi}$ , we get

$$e^{-\pi} = e^{-\pi} \cos 2\pi + 2 \sin \pi + \frac{1}{2} (A - 1) e^{-\pi} \sin 2\pi = e^{-\pi}.$$

This shows that for any value of  $A$  the given condition  $y(\pi) = e^{-\pi}$  holds good. Hence this gives the solution of the equation the initial conditions.

6. Solve using Laplace transforms,

$$y'' + 2y' + y = 6t e^{-t}$$

given  $y(0) = 0, y'(0) = 0$ .

**Solution**

$$y'' + 2y' + y = 6t e^{-t}$$

Taking the Laplace transforms on both sides of the given equation, we get

$$L(y'') + 2L(y') + L(y) = 6L(te^{-t})$$

$$s^2 L(y) - sy(0) - y'(0) + 2[sL(y) - y(0)] + L(y) = \frac{6}{(s+1)^2}$$

Since  $y(0) = 0, y'(0) = 0$

i.e.,  $s^2 L(y) + 2sL(y) + L(y) = \frac{6}{(s+1)^2}$

$$(s^2 + 2s + 1)L(y) = \frac{6}{(s+1)^2}$$

$$\begin{aligned} \therefore L(y) &= \frac{6}{(s+1)^2 (s^2 + 2s + 1)} \\ &= \frac{6}{(s+1)^2 (s+1)^2} \end{aligned}$$

$$L(y) = \frac{6}{(s+1)^4}$$

$$\begin{aligned} \therefore y &= 6L^{-1} \left\{ \frac{1}{(s+1)^4} \right\} \\ &= 6e^{-t} L^{-1} \left\{ \frac{1}{s^4} \right\} \\ &= 6e^{-t} \cdot \frac{t^3}{3!} \\ y &= t^3 e^{-t} \end{aligned}$$

This is the required solution.

7. Solve using Laplace transforms,

$$y''' - 3y'' + 3y' - y = t^2 e^t \quad \text{given } y(0) = 1, y'(0) = 0, y'''(0) = -2.$$

**Solution**

$$y''' - 3y'' + 3y' - y = t^2 e^t$$

Taking Laplace transforms on both sides, we get

$$L(y''') - 3L(y'') - 3L(y') - L(y) = L(t^2 e^t)$$

$$\text{i.e., } [s^3 L(y) - s^2 y(0) - sy'(0) - y''(0)] - 3[s^2 L(y) - sy(0) - y'(0)]$$

$$+ 3[sL(y) - y(0)] - L(y) = \frac{2}{(s-1)^3}.$$

$$\text{Since, } y'(0) = 0, \quad y(0) = 1, \quad y''(0) = -2$$

$$s^3 L(y) - s^2 + 2 - 3[s^2 L(y) - s] + 3[sL(y) - 1] - L(y) = \frac{2}{(s-1)^3}$$

$$\text{i.e., } (s^3 - 3s^2 + 3s - 1)L(y) + 3s - s^2 - 1 = \frac{2}{(s-1)^3}$$

$$(s^3 - 3s^2 + 3s - 1)L(y) = \frac{2}{(s-1)^3} + s^2 - 3s + 1$$

$$\text{i.e., } (s-1)^3 L(y) = \frac{2}{(s-1)^3} + s^2 - 3s + 1$$

$$\begin{aligned} \text{i.e., } L(y) &= \frac{2}{(s-1)^3 (s-1)^3} + \frac{s^2 - 3s + 1}{(s-1)^3} \\ &= \frac{2}{(s-1)^6} + \frac{s^2 - 2s + 1 - s}{(s-1)^3} \\ &= \frac{2}{(s-1)^6} + \frac{(s-1)^2 - (s-1) - 1}{(s-1)^3} \\ &= \frac{2}{(s-1)^6} + \frac{(s-1)^2}{(s-1)^3} - \frac{(s-1)}{(s-1)^3} - \frac{1}{(s-1)^3} \end{aligned}$$

$$L(y) = \frac{2}{(s-1)^6} + \frac{1}{s-1} - \frac{1}{(s-1)^2} - \frac{1}{(s-1)^3}$$

$$y = L^{-1} \left\{ \frac{2}{(s-1)^6} \right\} + L^{-1} \left\{ \frac{1}{s-1} \right\} - L^{-1} \left\{ \frac{1}{(s-1)^2} \right\} - L^{-1} \left\{ \frac{1}{(s-1)^3} \right\}$$

$$= \frac{t^5 e^t}{60} + e^t - t e^t - \frac{1}{2} t^2 e^t$$

which is the required solution.

8. Solve the D.E.  $y'' + 4y' + 3y = e^{-t}$  with  $y(0) = 1 = y'(0)$  using Laplace transforms.

**Solution.** Taking Laplace transform on both sides of the given equation, we have

$$L[y''(t)] + 4L[y'(t)] + 3L[y(t)] = L[e^{-t}]$$

$$\text{i.e., } \{s^2 L y(t) - s y(0) - y'(0)\} + 4 \{s L y(t) - y(0)\} + 3 L y(t) = \frac{1}{s+1}$$

Using the given initial condition, we obtain

$$(s^2 + 4s + 3) L y(t) - s - 1 - 4 = \frac{1}{s+1}$$

$$\text{i.e., } (s^2 + 4s + 3) L y(t) = (s + 5) + \frac{1}{(s+1)}$$

$$(s + 1)(s + 3) L y(t) = \frac{s^2 + 6s + 6}{s+1}$$

$$\therefore L[y(t)] = \frac{s^2 + 6s + 6}{(s+1)^2 (s+3)}$$

$$\therefore y(t) = L^{-1} \left[ \frac{s^2 + 6s + 6}{(s+1)^2 (s+3)} \right]$$

$$\text{Let } \frac{s^2 + 6s + 6}{(s+1)^2 (s+3)} = \frac{A}{s+1} + \frac{B}{(s+1)^2} + \frac{C}{s+3}$$

Multiplying by  $(s + 1)(s + 3)$ , we get

$$s^2 + 6s + 6 = A(s + 1)(s + 3) + B(s + 3) + C(s + 1)^2 \quad \dots(1)$$

$$\text{Put } s = -1; \quad 1 = B(2) \quad \Rightarrow \quad B = \frac{1}{2}$$

$$\text{Put } s = -3; \quad -3 = C(4) \quad \Rightarrow \quad C = -\frac{3}{4}$$

Equating the coefficient of  $s^2$  on both sides of (1), we get

$$1 = A + C \quad \left( \because A = \frac{7}{4} \right)$$

$$\text{Hence, } L^{-1} \left[ \frac{s^2 + 6s + 6}{(s+1)^2 (s+3)} \right] = \frac{7}{4} L^{-1} \left( \frac{1}{s+1} \right) + \frac{1}{2} L^{-1} \left[ \frac{1}{(s+1)^2} \right] - \frac{3}{4} L^{-1} \left( \frac{1}{s+3} \right)$$

$$\therefore y(t) = \frac{7}{4} e^{-t} + \frac{1}{2} e^{-t} \cdot t - \frac{3}{4} e^{-3t}.$$

### Solution of Simultaneous Differential Equations

9. Solve the simultaneous equations using Laplace transforms,  $\frac{dx}{dt} = 2x - 3y$ ,  $\frac{dy}{dt} = y - 2x$  subject to  $x(0) = 8$  and  $y(0) = 3$ .

**Solution.** We have,

$$x'(t) - 2x(t) + 3y(t) = 0$$

$$2x(t) + y'(t) - y(t) = 0$$

Taking Laplace transforms on both sides of these, we get

$$L[x'(t)] - 2L[x(t)] + 3L[y(t)] = 0$$

$$2L[x(t)] + L[y'(t)] - L[y(t)] = 0$$

i.e.,  $sLx(t) - x(0) - 2Lx(t) + 3Ly(t) = 0$

$$2Lx(t) + sLy(t) - y(0) - Ly(t) = 0$$

Using initial values,

Since,  $x(0) = 8$ , and  $y(0) = 3$ , we get

$$(s - 2)Lx(t) + 3Ly(t) = 8 \quad \dots(1)$$

$$2Lx(t) + (s - 1)Ly(t) = 3 \quad \dots(2)$$

Solving the Eqns. (1) and (2)

Multiplying  $(s - 1)$  in the Eqn. (1) and Multiplying 3 by (2)

$$(s - 1)(s - 2)Lx(t) + 3(s - 1)Ly(t) = 8(s - 1)$$

$$6Lx(t) + 3(s - 1)Ly(t) = 9$$

---

Subtracting, we get  $(s^2 - 3s - 4)Lx(t) = 8s - 17$

$$\therefore Lx(t) = \frac{8s - 17}{s^2 - 3s - 4}$$

$$\therefore x(t) = L^{-1} \left[ \frac{8s - 17}{(s - 4)(s + 1)} \right]$$

Let,  $\frac{8s - 17}{(s - 4)(s + 1)} = \frac{A}{s - 4} + \frac{B}{s + 1}$

$$8s - 17 = A(s + 1) + B(s - 4)$$

Put  $s = 4$ ,  $A = 3$

$$s = -1, \quad B = 5$$

$$\therefore x(t) = 3L^{-1} \left[ \frac{1}{s - 4} \right] + 5L^{-1} \left[ \frac{1}{s + 1} \right]$$

$$x(t) = 3e^{4t} + 5e^{-t} \quad \dots(3)$$

Consider,  $\frac{dx}{dt} = 2x - 3y$

$$\therefore y = \frac{1}{3} \left[ 2x - \frac{dx}{dt} \right] = \frac{1}{3} \left[ 2x(t) - \frac{dx}{dt} \right]$$

$$\frac{dx}{dt} = 12e^{4t} - 5e^{-t}$$

$$\begin{aligned} \therefore y(t) &= \frac{1}{3} \left[ 2(3e^{4t} + 5e^{-t}) - (12e^{4t} - 5e^{-t}) \right] \\ &= \frac{1}{3} (-6e^{4t} + 15e^{-t}) \\ y(t) &= 5e^{-t} - 2e^{4t} \end{aligned} \quad \dots(4)$$

Equations (3) and (4) represent the solution of the given equations.

**10. Solve by using Laplace transforms**

$$\frac{dx}{dt} - 2y = \cos 2t, \quad \frac{dy}{dt} + 2x = \sin 2t, \quad x = 1, \quad y = 0, \quad \text{at } t = 0.$$

**Solution.** We have a system of equations,

$$x'(t) - 2y(t) = \cos 2t \quad \dots(1)$$

$$2x(t) + y'(t) = \sin 2t \quad \dots(2)$$

where we have  $x(0) = 1$  and  $y(0) = 0$

Taking Laplace transforms on both sides of Eqns. (1) and (2), we have

$$L[x'(t)] + 2L[y(t)] = L(\cos 2t)$$

$$2L[x(t)] + L[y'(t)] = L(\sin 2t)$$

$$\text{i.e.,} \quad \{sLx(t) - x(0)\} - 2Ly(t) = \frac{s}{s^2 + 4}$$

$$2Lx(t) + \{sLy(t) - y(0)\} = \frac{2}{s^2 + 4}$$

Using the given initial values, we have

$$sLx(t) - 2Ly(t) = \frac{s}{s^2 + 4} + 1 \quad \dots(3)$$

$$2Lx(t) + sLy(t) = \frac{2}{s^2 + 4} \quad \dots(4)$$

Let us multiply Eqn. (3) by  $s$  and Eqn. (4) by 2

$$s^2Lx(t) - 2sLy(t) = \frac{s^2}{s^2 + 4} + s$$

$$4Lx(t) + 2sLy(t) = \frac{4}{s^2 + 4}$$

Adding, we get  $(s^2 + 4)Lx(t) = \frac{s^2}{s^2 + 4} + \frac{4}{s^2 + 4} + s$

$$= s + 1$$

i.e.,  $(s^2 + 4)Lx(t) = s + 1$



$$\therefore Lx(t) = \frac{s+1}{s^2+4}$$

$$\therefore x(t) = L^{-1} \left[ \frac{s}{s^2+2^2} \right] + L^{-1} \left[ \frac{1}{s^2+2^2} \right]$$

$$\text{Thus } x(t) = \cos 2t + \frac{1}{2} \sin 2t \quad \dots(5)$$

To find  $y(t)$ , let us consider,

$$\frac{dx}{dt} - 2y = \cos 2t$$

$$\therefore y = \frac{1}{2} \left[ \frac{dx}{dt} - \cos 2t \right]$$

$$\therefore y(t) = \frac{1}{2} \left[ \frac{dx}{dt} - \cos 2t \right]$$

where  $\frac{dx}{dt} = -2 \sin 2t + \cos 2t$ .

$$\therefore y(t) = \frac{1}{2} [-2 \sin 2t + \cos 2t - \cos 2t]$$

$$\therefore y(t) = -\sin 2t \quad \dots(6)$$

$\therefore$  Eqns. (5) and (6) represent the required solution.

**11.** Solve the following system of equations using Laplace transforms,

$$\frac{dx}{dt} - y = e^t, \quad \frac{dy}{dt} + x = \sin t$$

given that  $x = 1, y = 0$  at  $t = 0$ .

**Solution**

$$\text{We have } x'(t) - y(t) = e^t \quad \dots(1)$$

$$x(t) + y'(t) = \sin t \quad \dots(2)$$

where we have  $x(0) = 1, y(0) = 0$

Taking Laplace transforms on both sides of Eqns. (1) and (2)

$$L[x'(t)] - L[y(t)] = L[e^t]$$

$$L[x(t)] + L[y'(t)] = L[\sin t]$$

$$\text{i.e., } sLx(t) - x(0) - Ly(t) = \frac{1}{s-1}$$

$$Lx(t) + sLy(t) - y(0) = \frac{1}{s^2+1}$$

Using the given initial values, we have

$$sLx(t) - 1 - Ly(t) = \frac{1}{s-1}$$

$$\Rightarrow \quad sLx(t) - Ly(t) = \frac{1}{s-1} + 1 \quad \dots(3)$$

$$\Rightarrow \quad Lx(t) + sLy(t) = \frac{1}{s^2 + 1} \quad \dots(4)$$

Let us multiplying 5 by Eqn. (3) and adding Eqn. (4), we get

$$(s^2 + 1)Lx(t) = s + \frac{s}{s-1} + \frac{1}{s^2 + 1}$$

$$\therefore \quad Lx(t) = \frac{s}{s^2 + 1} + \frac{s}{(s-1)(s^2 + 1)} + \frac{1}{(s^2 + 1)^2}$$

$$x(t) = L^{-1}\left[\frac{s}{s^2 + 1}\right] + L^{-1}\left[\frac{s}{(s-1)(s^2 + 1)}\right] + L^{-1}\left[\frac{1}{(s^2 + 1)^2}\right] \quad \dots(5)$$

Let 
$$\frac{s}{(s-1)(s^2 + 1)} = \frac{A}{s-1} + \frac{Bs + C}{s^2 + 1}$$

$$s = A(s^2 + 1) + (Bs + C)(s - 1)$$

Put  $s = 1, \quad \therefore A = \frac{1}{2}$

$$s = 0, \quad C = \frac{1}{2}$$

Equating the coefficient of  $s^2$  on both sides, we get

$$0 = A + B \quad \therefore B = -\frac{1}{2}$$

Now, 
$$L^{-1}\left[\frac{s}{(s-1)(s^2 + 1)}\right] = \frac{1}{2}L^{-1}\left[\frac{1}{s-1}\right] - \frac{1}{2}L^{-1}\left[\frac{s}{s^2 + 1}\right] + \frac{1}{2}L^{-1}\left[\frac{1}{s^2 + 1}\right]$$

$$= \frac{1}{2}(e^t - \cos t + \sin t) \quad \dots(6)$$

Further, we have

$$L^{-1}\frac{1}{(s^2 + a^2)^2} = \frac{1}{2a^3}(\sin at - at \cos at)$$

$$\therefore \quad L^{-1}\left[\frac{1}{(s^2 + 1)^2}\right] = \frac{1}{2}(\sin t - t \cos t) \quad \dots(7)$$

Equation (5) as a consequence of Eqns. (6) and (7) becomes,

$$x(t) = \cos t + \frac{1}{2}(e^t - \cos t + \sin t) + \frac{1}{2}(\sin t - t \cos t)$$

$$x(t) = \frac{1}{2} (e^t + \cos t + 2 \sin t - t \cos t) \quad \dots(8)$$

Also from Eqn. (1),  $y(t) = \frac{dx}{dt} - e^t$

$$\frac{dx}{dt} = \frac{1}{2} (e^t - \sin t + 2 \cos t + t \sin t - \cos t)$$

$$\therefore y(t) = \frac{1}{2} (e^t - \sin t + 2 \cos t + t \sin t - \cos t) - e^t$$

$$y(t) = \frac{1}{2} (t \sin t + \cos t - \sin t - e^t) \quad \dots(9)$$

Eqns. (8) and (9) represent the solution of the given equations.

### EXERCISE 8.4

Using Laplace transforms method solve the following differential equations under the given conditions.

1.  $y' - 5y = e^{5t}$ ,  $y(0) = 2$ . [Ans.  $y = (2+t)e^{5t}$ ]

2.  $y' + 3y = 2$ ,  $y(0) = -1$ . [Ans.  $y = \frac{2}{3} - \frac{5}{3}e^{-3t}$ ]

3.  $y' + y = \sin t$ ,  $y(0) = 1$ . [Ans.  $y = \frac{3}{2}e^{-t} - \frac{1}{2}\cos t + \frac{1}{2}\sin t$ ]

4.  $y' - 2y = t$ ,  $y(0) = \frac{7}{4}$ . [Ans.  $y = 2e^{-2t} + \frac{1}{2}t - \frac{1}{4}$ ]

5.  $y' - y = \cos 2t$ ,  $y(0) = \frac{4}{5}$ . [Ans.  $y = e^t + \frac{1}{5}(-\cos 2t + 2 \sin 2t)$ ]

6.  $y'' + y = 0$ ,  $y(0) = 1$ ,  $y'(0) = -1$ . [Ans.  $y = \cos t - \sin t$ ]

7.  $y'' + 3y' + 12y = 0$ ,  $y(0) = 7$ ,  $y'(0) = -11$ . [Ans.  $y = 3e^{-t} + 4e^{-2t}$ ]

8.  $y'' - 7y' + 12y = 0$ ,  $y'(0) = 9$ ,  $y(0) = 2$ . [Ans.  $y = 4e^{3t} + 5e^{2t}$ ]

9.  $y'' + 3y' - 4y = 12e^{2t}$ ,  $y(0) = 4$ ,  $y'(0) = 1$ . [Ans.  $y = e^t + e^{-4t} + 2e^{2t}$ ]

10.  $y'' - 3y' + 2y = 1 - e^{2t}$ ,  $y(0) = 1$ ,  $y'(0) = 0$ . [Ans.  $y = \frac{1}{2} - \frac{1}{2}e^{2t} - te^{2t}$ ]

11.  $y'' + 5y' + 6y = 5e^{2t}$ ,  $y(0) = 2$ ,  $y'(0) = 1$ . [Ans.  $y = \frac{23}{4}e^{-2t} - 4e^{-3t} + \frac{1}{4}e^{2t}$ ]

12.  $y'' + 9y = \cos 2t$ ,  $y(0) = 1$ ,  $y\left(\frac{\pi}{2}\right) = -1$ . [Ans.  $y = \frac{4}{5}\cos 3t + \frac{4}{5}\sin 3t + \frac{1}{5}\cos 2t$ ]

13.  $y'' - 3y' + 2y = e^{3t}$ ,  $y(0) = 1$ ,  $y'(0) = -1$ . [Ans.  $y = \frac{7}{2}e^t - 3e^{2t} + \frac{1}{2}e^{3t}$ ]

14.  $y'' + 2y' + 5y = e^{-t} \sin t$ ,  $y(0) = 0$ ,  $y'(0) = 1$ . [Ans.  $y = \frac{1}{3}e^{-t}(\sin t + \sin 2t)$ ]

15.  $y'' + 4y = 9t$ ,  $y(0) = 0$ ,  $y'(0) = 7$ . [Ans.  $y = 3t + \sin 2t$ ]

16.  $y'' - 3y' + 2y = 4t + 12e^{-t}$ ,  $y(0) = 6$ ,  $y'(0) = 1$ . [Ans.  $y = 3e^t - 2e^{2t} + 2t + 3 + 2e^{-t}$ ]

17.  $y'' - 4y' + 5y = 12t^2$ ,  $y(0) = 0 = y'(0) = 0$ . [Ans.  $y = 25t^2 + 40t + 22 + 2e^{2t}(2 \sin t - 11 \cos t)$ ]

18.  $y'' + y = 8 \cos t$ ,  $y(0) = 1$ ,  $y'(0) = -1$ . [Ans.  $y = \cos t - 4 \sin t + 4t \cos t$ ]

19.  $y'' + 9y = 18t$ ,  $y(0) = 0$ ,  $y\left(\frac{\pi}{2}\right) = 0$ . [Ans.  $y = 2t + \pi \sin 3t$ ]

20.  $y'' + 2y' + 5y = 10 \sin t$ ,  $y(0) = 0$ ,  $y'(0) = -1$ . [Ans.  $y = \cos t - \cos 2t$ ]

Using Laplace transforms method solve the following simultaneous equations:

1.  $x' = x + y$ ,  $y' = 4x - 2y$  given  $x(0) = 0$ ,  $y(0) = 5$ . [Ans.  $x = -e^{-3t} + e^{2t}$ ;  $y = 4e^{-3t} + e^{2t}$ ]

2.  $x' + 2x + y = 0$ ,  $x + y' + 2y$ , given  $x(0) = 1$ ,  $y(0) = 3$ . [Ans.  $x = -e^{-t} + 2e^{-3t}$ ;  $y = e^{-t} + 2e^{-3t}$ ]

3.  $x' + y' + 2x + y = 0$ ,  $y' + 5x + 3y = 0$  given  $x(0) = 0$ ,  $y(0) = 4$ . [Ans.  $x = 8 \sin t$ ;  $y = -12 \sin t + 4 \cos t$ ]

4.  $x' + 5x - 2y = t$ ,  $y' + 2x + y = 0$  given  $x(0) = y(0) = 0$ . [Ans.  $x = \frac{1}{27}(1 + 3t) - \frac{1}{27}(1 + 6t)e^{-3t}$ ;  $y = \frac{2}{27}(2 - 3t) - \frac{2}{27}(2 + 3t)e^{-3t}$ ]

5.  $x' - y = e^t$ ,  $y' + x = \sin t$ , given  $x(0) = 1$ ,  $y(0) = 0$ . [Ans.  $x = \frac{1}{2}(e^t + \cos t + 2 \sin t - t \cos t)$ ;  $y = \frac{1}{2}(t \sin t - e^t + \cos t - \sin t)$ ]

6.  $x'' + 3x - 2y = 0$ ,  $x'' + y'' - 3x + 5y = 0$  given  $x = 0$ ,  $y = 0$ ,  $x' = 3$ ,  $y' = 2$  when  $t = 0$ . [Ans.  $x = \frac{11}{4} \sin t + \frac{1}{12} \sin 3t$ ;  $y = \frac{11}{4} \sin t - \frac{1}{4} \sin 3t$ ]

## 8.8 APPLICATIONS OF LAPLACE TRANSFORMS

In this section we shall consider some applications of the Laplace transforms to solve the problems on vibrations, LRC circuits and bending beams.

### WORKED OUT EXAMPLES

1. A particle moves along the  $x$ -axis according to the law  $\frac{d^2x}{dt^2} + 6\frac{dx}{dt} + 25x = 0$ . If the particle is started at  $x = 0$ , with an initial velocity of 12 ft/sec to the left, determine  $x$  in terms of  $t$  using Laplace transform method.

**Solution.** The given equation is

$$x''(t) + 6x'(t) + 25x(t) = 0 \quad \dots(1)$$

and  $x = 0$  at  $t = 0$ ,  $\frac{dx}{dt} = -12$  at  $t = 0$ , By data

*i.e.*,  $x(0) = 0$ ,  $x'(0) = -12$  are the initial conditions.

Now taking Laplace transform on both sides of (1) we have

$$L[x''(t)] + 6L[x'(t)] + 25L[x(t)] = L(0)$$

$$*i.e.*, \{s^2 Lx(t) - sx(0) - x'(0)\} + 6\{sLx(t) - x(0)\} + 25Lx(t) = 0$$

Using the initial conditions we obtain,

$$(s^2 + 6s + 25)Lx(t) = -12$$

$$\Rightarrow Lx(t) = \frac{-12}{s^2 + 6s + 25}$$

$$x(t) = -12L^{-1}\left[\frac{1}{s^2 + 6s + 25}\right]$$

$$= -12L^{-1}\left[\frac{1}{(s+3)^2 + 4^2}\right]$$

$$= -12e^{-3t}L^{-1}\left[\frac{1}{s^2 + 4^2}\right]$$

$$= -12e^{-3t}\frac{\sin 4t}{4}$$

Thus,  $x(t) = -3e^{-3t}\sin 4t.$

2. A particle is moving with damped motion according to the law  $\frac{d^2x}{dt^2} + 6\frac{dx}{dt} + 25x = 0$ . If the initial position of the particle is at  $x = 20$  and the initial speed is 10, find the displacement of the particle at any time  $t$  using Laplace transforms.

**Solution.** We have

$$x''(t) + 6x'(t) + 25x(t) = 0$$

Initial conditions  $x(0) = 20, x'(0) = 10$

Taking Laplace transforms on both sides,

we get  $L[x''(t)] + 6L[x'(t)] + 25L[x(t)] = L(0)$

*i.e.*,  $\{s^2 L x(t) - s x(0) - x'(0)\} + 6\{sL x(t) - x(0)\} + 25L x(t) = 0$

*i.e.*,  $(s^2 + 6s + 25) L x(t) - 20s - 10 - 120 = 0$

$$L x(t) = \frac{20s + 130}{s^2 + 6s + 25}$$

$$x(t) = L^{-1} \left[ \frac{20s + 130}{(s + 3)^2 + 16} \right]$$

$$= L^{-1} \left[ \frac{20(s + 3) + 70}{(s + 3)^2 + 4^2} \right]$$

$$= e^{-3t} L^{-1} \left[ \frac{20s + 70}{s^2 + 4^2} \right]$$

$$= e^{-3t} \left[ 20 \cos 4t + \frac{70}{4} \sin 4t \right]$$

$\therefore$  
$$x(t) = 10 e^{-3t} \left( 2 \cos 4t + \frac{7}{4} \sin 4t \right).$$

3. The current  $i$  and charge  $q$  in a series circuit containing an inductance  $L$ , capacitance  $C$  e.m.f

$E$  satisfy the D.E.  $L \frac{di}{dt} + \frac{q}{C} = E$ ,  $i = \frac{dq}{dt}$ . Express  $i$  and  $q$  in terms of  $t$  given that  $L, C, E$  are constants and the value of  $i, q$  are both zero initially.

**Solution**

Since  $i = \frac{dq}{dt}$  the D.E. becomes,

$$L \frac{d^2q}{dt^2} + \frac{q}{C} = E$$

or

$$\Rightarrow \frac{d^2q}{dt^2} + \frac{q}{LC} = \frac{E}{L}$$

*i.e.*,  $q''(t) + \lambda^2 q(t) = \mu$

where  $\lambda^2 = \frac{1}{LC}$  and  $\mu = \frac{E}{L}$ .

Taking Laplace transforms on both sides, we get

$$L [q''(t)] + \lambda^2 L [q(t)] = L [\mu]$$

$$\{s^2 L q(t) - s q(0) - q'(0)\} + \lambda^2 L q(t) = \frac{\mu}{s}$$

But  $i = 0, q = 0$  at  $t = 0$

*i.e.*,  $q(0) = 0, q'(0) = 0$

$\therefore$  
$$(s^2 + \lambda^2) L q(t) = \frac{\mu}{s}$$

$$L q(t) = \frac{\mu}{s(s^2 + \lambda^2)}$$

Hence,

$$q(t) = L^{-1} \left\{ \frac{\mu}{s(s^2 + \lambda^2)} \right\}$$

$$\frac{1}{s^2(s^2 + \lambda^2)} = \frac{1}{\lambda^2} \left[ \frac{1}{s} - \frac{s}{s^2 + \lambda^2} \right] \text{ By partial fractions}$$

$$= L^{-1} \left[ \frac{\mu}{s(s^2 + \lambda^2)} \right] = \frac{\mu}{\lambda^2} L^{-1} \left[ \frac{1}{s} - \frac{s}{s^2 + \lambda^2} \right]$$

$$\therefore q(t) = \frac{\mu}{\lambda^2} (1 - \cos \lambda t)$$

where  $\lambda = \frac{1}{LC}$  and  $\mu = \frac{E}{L}$

$$\therefore q(t) = EC \left\{ 1 - \cos \sqrt{\frac{1}{LC}} t \right\}.$$

4. A resistance  $R$  in series with inductance  $L$  is connected with e.m.f.  $E(t)$ . The current is given by  $L \frac{di}{dt} + Ri = E(t)$ . If the switch is connected at  $t = 0$  and disconnected at  $t = a$ , find the current  $i$  in terms of 't'.

**Solution.** We have

$$i = 0 \quad \text{at} \quad t = 0$$

i.e.,

$$i(0) = 0$$

and

$$E(t) = \begin{cases} E & \text{in } 0 < t < a \\ 0 & \text{if } t \geq a \end{cases}$$

By date

$$Li'(t) + Ri(t) = E(t)$$

Taking Laplace transforms on both sides

$$L L[i'(t)] + R L[i(t)] = L[E(t)]$$

$$L\{sL i(t) - i(0)\} + RL i(t) = L[E(t)]$$

$$L i(t) [Ls + R] = L[E(t)] \quad \dots(1)$$

Now to find  $L[E(t)]$

We have by definition,

$$\begin{aligned} L[E(t)] &= \int_0^{\infty} e^{-st} E(t) dt = \int_0^a e^{-st} \cdot E dt + \int_a^{\infty} e^{-st} dt \\ &= E \left[ \frac{e^{-st}}{-s} \right]_0^a = \frac{-E}{s} (e^{-as} - 1) \\ &= \frac{E}{s} (1 - e^{-as}) \end{aligned}$$

Using R.H.S. of Eqn. (1), we have

$$\begin{aligned}
 L i(t) [Ls + R] &= \frac{E}{s} (1 - e^{-as}) \\
 L i(t) &= \frac{E (1 - e^{-as})}{s(Ls + R)} \\
 &= \frac{E}{s(Ls + R)} - \frac{E e^{-as}}{s(Ls + R)} \\
 i(t) &= L^{-1} \left[ \frac{E}{s(Ls + R)} \right] - L^{-1} \left[ \frac{E e^{-as}}{s(Ls + R)} \right] \quad \dots(2)
 \end{aligned}$$

Now, let  $\frac{E}{s(Ls + R)} = \frac{A}{s} + \frac{B}{Ls + R}$  (Partial fractions)

$$E = A(Ls + R) + Bs$$

Put  $s = 0, A = \frac{E}{R}$

$$s = \frac{-R}{L}, B = \frac{-EL}{R}$$

Thus,  $\frac{E}{s(Ls + R)} = \frac{E}{R} \cdot \frac{1}{s} - \frac{EL}{R} \cdot \frac{1}{Ls + R}$

$$\begin{aligned}
 L^{-1} \left[ \frac{E}{s(Ls + R)} \right] &= \frac{E}{R} L^{-1} \left[ \frac{1}{s} \right] - \frac{EL}{R} L^{-1} \left[ \frac{1}{\left( s + \frac{R}{L} \right)} \right] \\
 &= \frac{E}{R} \left( 1 - e^{-\frac{Rt}{L}} \right) \quad \dots(3)
 \end{aligned}$$

Further we have the property of the unit step function

$$L [f(t - a) u(t - a)] = e^{-as} \bar{f}(s)$$

where  $\bar{f}(s) = L[f(t)]$

Taking  $\bar{f}(s) = \frac{E}{s(Ls + R)}$

Then  $L^{-1} [\bar{f}(s)] = L^{-1} \left[ \frac{E}{s(Ls + R)} \right]$

i.e.,  $f(t) = \frac{E}{R} (1 - e^{-Rt/L})$  By Eqn. (3)

Also  $L^{-1} [e^{-as} \bar{f}(s)] = f(t - a) u(t - a)$



$$i.e., \quad L^{-1} \left[ e^{-as} \frac{E}{s(Ls + R)} \right] = \frac{E}{R} \left[ 1 - e^{-R(t-a)/L} \right] u(t-a)$$

$$\text{But} \quad u(t-a) = \begin{cases} 0 & \text{in } 0 < t < a \\ 1 & \text{if } t \geq a \end{cases}$$

$$\therefore \quad L^{-1} \left[ e^{-as} \frac{E}{s(Ls + R)} \right] = \frac{E}{R} \left[ 1 - e^{-R(t-a)/L} \right] \quad \dots(4)$$

when  $t \geq a = 0$  in  $0 < t < a$

Using the results Eqns. (3) and (4) in Eqn. (2), we have

$$i(t) = \frac{E}{R} \left[ 1 - e^{-Rt/L} \right] \text{ in } 0 < t < a \quad \dots(5)$$

$$\text{Also,} \quad i(t) = \frac{E}{R} \left[ 1 - e^{-Rt/L} \right] - \frac{E}{R} \left[ 1 - e^{-R(t-a)/L} \right]$$

when  $t \geq a$

$$i.e., \quad i(t) = \frac{E}{R} \left[ e^{-R(t-a)/L} - e^{-Rt/L} \right] \quad \dots(6)$$

when  $t \geq a$

Thus Eqns. (5) and (6) represent the required  $i(t)$  in terms of  $t$ .

### EXERCISE 8.5

1. A particle undergoes forced vibrations according to the equation  $\frac{d^2x}{dt^2} + 25 = 21 \cos 2t$ . If the particle starts from rest at  $t = 0$ , find the displacement at any time  $t > 0$ .

$$[\text{Ans. } x = \cos 2t - \cos 5t]$$

2. A particle moves along a line so that its displacement  $x$  from a fixed point  $o$  at any time  $t$  is given by

$$x'' + 2x' + 5x = 52 \sin 3t. \text{ If at } t = 0 \text{ the particle is at rest at } x = 0. \text{ Find the displacement at any}$$

time  $t > 0$ .

$$[\text{Ans. } x = e^{-t} (6 \cos 2t + 9 \sin 2t) - 2 (3 \cos 3t + 2 \sin 3t)]$$

3. A particle of mass  $m$  moves along a line so that its displacement  $x$  at time  $t$  is given by  $mx'' + kx = f(t)$ , where  $x(0) = a$ ,  $x'(0) = 0$ .

Find  $x$  if

(i)  $f(t) = f_0 H(t - T)$  where  $H(t - T)$  is the Heaviside unit step function.

$$\left[ \begin{array}{l} \text{Ans. } x = af_0 \cos \mu t \text{ if } t < T \\ \quad \quad = af_0 \cos \mu t + (f_0/k) \{1 - \cos \mu(t - T)\} \\ \text{if } t > T \\ \text{where } \mu^2 = k/m \end{array} \right]$$

(ii)  $f(t) = f_0 \delta(t - T)$  (Direct delta function).

$$\left[ \begin{aligned} \text{Ans. } x &= af_0 \cos \mu t \text{ if } t < T \\ &= af_0 \cos \mu t + (f_0/\mu) \sin \mu (t - T) \text{ if } t > T \end{aligned} \right]$$

4. A particle is moving with damped motion according to the equation  $\frac{d^2x}{dt^2} + 6\frac{dx}{dt} + 25x = 0$ . If the initial position of the particle is at  $x = 20$  and the initial speed is 10 find the displacement of the particle at any time  $t > 0$ .

$$\left[ \text{Ans. } x = 10e^{-3t} (2 \cos 4t + \sin 4t) \right]$$

**ADDITIONAL PROBLEMS (From Previous Years VTU Exams.)**

1. Find the Inverse Laplace transform of  $\frac{s+1}{(s-1)^2(s+2)}$ .

**Solution.** Let  $\frac{s+1}{(s-1)^2(s+2)} = \frac{A}{s-1} + \frac{B}{(s-1)^2} + \frac{C}{s+2}$

or  $s + 1 = A(s-1)(s+2) + B(s+2) + C(s-1)^2$

Put  $s = 1 \quad \therefore B = \frac{2}{3}$

Put  $s = -2 \quad \therefore C = \frac{-1}{9}$

Equating the coefficient of  $s^2$  on both sides

We have  $0 = A + C \quad \therefore A = \frac{1}{9}$

$$\begin{aligned} \text{Now, } L^{-1} \left[ \frac{s+1}{(s-1)^2(s+2)} \right] &= \frac{1}{9} L^{-1} \left[ \frac{1}{s-1} \right] + \frac{2}{3} L^{-1} \left[ \frac{1}{(s-1)^2} \right] - \frac{1}{9} L^{-1} \left[ \frac{1}{s+2} \right] \\ &= \frac{1}{9} e^t + \frac{2}{3} e^t L^{-1} \left[ \frac{1}{s^2} \right] - \frac{1}{9} e^{-2t} \\ &= \frac{1}{9} e^t + \frac{2}{3} e^t \cdot t - \frac{1}{9} e^{-2t} \end{aligned}$$

Thus  $L^{-1} \left[ \frac{s+1}{(s-1)^2(s+2)} \right] = \frac{1}{9} e^t + \frac{2}{3} e^t \cdot t - \frac{1}{9} e^{-2t}$ .

2. Evaluate  $L^{-1} \left[ \frac{1}{s+3} + \frac{s+3}{s^2+6s+13} - \frac{1}{(s-2)^3} \right]$ .

**Solution**

We have  $L^{-1} \left[ \frac{1}{s+3} \right] + L^{-1} \left[ \frac{s+3}{s^2+6s+13} \right] - L^{-1} \left[ \frac{1}{(s-2)^3} \right]$

$$L^{-1} \left[ \frac{1}{s+3} \right] = e^{-3t}$$

$$L^{-1} \left[ \frac{s+3}{(s+3)^2+4} \right]_{s+3 \rightarrow s} = e^{-3t} L^{-1} \left[ \frac{s}{s^2-2^2} \right]$$

$$= e^{-3t} \cos 2t$$

$$L^{-1} \left[ \frac{1}{(s-2)^3} \right] = e^{2t} L^{-1} \left[ \frac{1}{s^3} \right] = e^{2t} \frac{t^2}{2!}$$

$$= \frac{e^{2t} t^2}{2}$$

Thus the required inverse Laplace transform is given by  $e^{-3t} + e^{-3t} \cos 2t - \frac{e^{2t} t^2}{2}$ .

3. Find the inverse Laplace transform of

(i)  $\frac{2s-1}{s^2+2s+17}$                       (ii)  $\frac{e^{-2s}}{(s-3)^2}$ .

**Solution**

(i)  $\frac{2s-1}{s^2+2s+17} = \frac{2s-1}{(s+1)^2+4^2} = \frac{2(s+1)-3}{(s+1)^2+4^2}$

$$L^{-1} \left[ \frac{2s-1}{s^2+2s+17} \right] = L^{-1} \left[ \frac{2(s+1)-3}{(s+1)^2+4^2} \right]$$

$$= e^{-t} L^{-1} \left[ \frac{2s-3}{s^2+4} \right]$$

$$= e^{-t} \left\{ 2L^{-1} \left[ \frac{s}{s^2+4} \right] - 3L^{-1} \left[ \frac{1}{s^2+4^2} \right] \right\}$$

Thus  $L^{-1} \left[ \frac{2s-1}{s^2+2s+17} \right] = e^{-t} \left( 2 \cos 4t - \frac{3}{4} \sin 4t \right)$ .

$$(ii) \quad L^{-1} \left\{ \frac{1}{(s-3)^2} \right\} = e^{3t} L^{-1} \left( \frac{1}{s^2} \right) = e^{3t} (t) = f(t)$$

Now, 
$$L^{-1} \left( \frac{e^{-2s}}{(s-3)^2} \right) = f(t-2) u(t-2)$$

Thus, 
$$L^{-1} \left( \frac{e^{-2s}}{(s-3)^2} \right) = \left\{ e^{3(t-2)}(t-2) \right\} u(t-2).$$

4. Using Convolution theorem, find the inverse Laplace transform of  $\frac{s}{(s+2)(s^2+9)}$ .

**Solution.** Let 
$$\bar{f}(s) = \frac{1}{s+2}; \quad \bar{g}(s) = \frac{s}{s^2+3^2}$$

$$\therefore L^{-1}[\bar{f}(s)] = f(t) = e^{-2t}$$

$$L^{-1}[\bar{g}(s)] = \bar{g}(t) = \cos 3t$$

We have Convolution theorem

$$L^{-1}[\bar{f}(s) \cdot \bar{g}(s)] = \int_{u=0}^t f(u)g(t-u) du$$

$$L^{-1} \left[ \frac{s}{(s+2)(s^2+3^2)} \right] = \int_{u=0}^t e^{-2u} \cos(3t-3u) du$$

$$\begin{aligned} \text{R.H.S.} &= \left[ \frac{e^{-2u}}{4+9} \{-2 \cos(3t-3u) - 3 \sin(3t-3u)\} \right]_{u=0}^t \\ &= \frac{1}{13} \{e^{-2u}(-2) - (-2 \cos 3t - 3 \sin 3t)\} \end{aligned}$$

Thus 
$$L^{-1} \left[ \frac{s}{(s+2)(s^2+9)} \right] = \frac{1}{13} (2 \cos 3t + 3 \sin 3t - 2e^{-2u})$$

5. Using Laplace transform method, solve  $\frac{d^3y}{dt^3} - 3 \frac{d^2y}{dt^2} + 3 \frac{dy}{dt} - y = t^2 e^t$  given  $y(0) = 1$ ,  $y'(0) = 0$ ,  $y''(0) = -2$ .

**Solution.** The given equation is

$$y'''(t) - 3y''(t) + 3y'(t) - y(t) = t^2 e^t$$

Taking Laplace transform on both sides, we have

$$[y'''(t)] - 3L[y''(t)] + 3L[y'(t)] - L[y(t)] = L[t^2 e^t]$$

$$s^3 \{L y(t) - s^2 y(0) - s y'(0) - y''(0)\} - 3 \{s^2 L y(t) - s y(0) - y'(0)\} + 3 \{s L y(t) - y(0)\} - L y(t) = \frac{2}{(s-1)^3}$$

Using the given initial conditions, we have

$$= (s^3 - 3s^2 + 3s - 1) L y(t) - s^2 + 2 + 3s - 3 = \frac{2}{(s-1)^3}$$

$$\text{i.e.,} \quad (s-1)^3 L y(t) = (s^2 - 3s + 1) + \frac{2}{(s-1)^3}$$

$$L y(t) = \frac{(s^2 - 3s + 1)}{(s-1)^3} + \frac{2}{(s-1)^6} \quad \dots(1)$$

$$\text{Now,} \quad L^{-1} \left[ \frac{s^2 - 3s + 1}{(s-1)^3} \right] = L^{-1} \left[ \frac{\{(s-1)^2 + 2s - 1\} - 3s + 1}{(s-1)^3} \right]$$

$$\begin{aligned} L^{-1} \left[ \frac{(s-1)^2 - s}{(s-1)^3} \right] &= L^{-1} \left[ \frac{(s-1)^2 - (s-1) - 1}{(s-1)^3} \right]_{s-1 \rightarrow s} \\ &= e^{+t} L^{-1} \left[ \frac{s^2 - s - 1}{s^3} \right] \\ &= e^t L^{-1} \left( \frac{1}{s} \right) - L^{-1} \left( \frac{1}{s^2} \right) - L^{-1} \left( \frac{1}{s^3} \right) \end{aligned}$$

$$\therefore L^{-1} \left[ \frac{s^2 - 3s + 1}{(s-1)^3} \right] = e^t \left( 1 - t - \frac{t^2}{2} \right)$$

$$\begin{aligned} \text{Also} \quad L^{-1} \left[ \frac{2}{(s-1)^6} \right] &= 2e^t L^{-1} \left( \frac{2}{s^6} \right) = 2e^t \frac{t^5}{5!} \\ &= \frac{e^t t^5}{60} \end{aligned}$$

Thus by using these results in the R.H.S. of (1), we have

$$y(t) = e^t \left\{ 1 - t - \frac{t^2}{2} + \frac{t^5}{60} \right\}.$$

6. Solve using Laplace transform, the differential equation  $\frac{d^2 y}{dx^2} - 3 \frac{dy}{dx} + 2y = 1 - e^{2x}$  given that

$$y(0) = 1 \text{ and } \frac{dy}{dx} = 1 \text{ at } x = 0.$$

**Solution.** We have to solve

$$y''(x) - 3y'(x) + 2y(x) = 1 - e^{2x}$$

Subject to the conditions  $y(0) = 1$  and  $y'(0) = 1$

Taking Laplace transforms on both sides of the given equations, we have

$$L[y''(x)] - 3L[y'(x)] + 2L[y(x)] = L[1 - e^{2x}]$$

$$\text{i.e., } \{s^2 L y(x) - s y(0) - y'(0)\} - 3 \{s L y(x) - y(0)\} + 2L y(x) = \frac{1}{s} - \frac{1}{s-2}$$

Using the given initial conditions, we have

$$(s^2 - 3s + 2) L y(x) - s - 1 + 3 = -\frac{2}{s(s-2)}$$

$$(s^2 - 3s + 2) L y(x) = (s - 2) - \frac{2}{s(s-2)}$$

$$\text{i.e., } (s - 1)(s - 2) L y(x) = (s - 2) - \frac{2}{s(s-2)}$$

$$L y(x) = \frac{1}{s-1} - \frac{2}{s(s-1)(s-2)}$$

$$\therefore y(x) = L^{-1}\left[\frac{1}{s-1}\right] - L^{-1}\left[\frac{2}{s(s-1)(s-2)^2}\right] \quad \dots(1)$$

$$\text{Let } \frac{2}{s(s-1)(s-2)^2} = \frac{A}{s} + \frac{B}{s-1} + \frac{C}{s-2} + \frac{D}{(s-2)^2}$$

$$\text{or } 2 = A(s-1)(s-2)^2 + B s(s-2)^2 + C s(s-1)(s-2) + D s(s-1)$$

$$\text{Put } s = 0, \quad A = \frac{-1}{2}$$

$$s = 1, \quad B = 2$$

$$s = 2, \quad D = 1$$

Also by equating the coefficients of  $s^3$  on both sides, we get

$$0 = A + B + C \quad \therefore C = \frac{-3}{2}$$

$$\text{Now } L^{-1}\left[\frac{2}{s(s-1)(s-2)^2}\right] = -\frac{1}{2} L^{-1}\left(\frac{1}{s}\right) + 2L^{-1}\left(\frac{1}{s-1}\right) - \frac{3}{2} L^{-1}\left(\frac{1}{s-2}\right) + L^{-1}\left(\frac{1}{(s-2)^2}\right)$$

$$= \frac{-1}{2} \cdot 1 + 2e^x - \frac{3}{2} e^{2x} + e^{2x} \cdot x$$

Hence (1) becomes

$$y(x) = e^x + \frac{1}{2} - 2e^x + \frac{3}{2}e^{2x} - e^{2x} \cdot x$$

Thus,

$$y(x) = \frac{1}{2} - e^x + \frac{3}{2}e^{2x} - xe^{2x} \text{ is the required solution.}$$

### OBJECTIVE QUESTIONS

1.  $L^{-1} \frac{1}{s(s^2 + 1)}$  is

(a)  $1 - \cos t$

(b)  $1 + \cos t$

(c)  $1 - \sin t$

(d)  $1 + \sin t$

[Ans. a]

2. The inverse Laplace transform of  $\frac{(e^{-3s})}{s^3}$  is

(a)  $(t - 3) u_3(t)$

(b)  $(t - 3)^2 u_3(t)$

(c)  $(t - 3)^3 u_3(t)$

(d)  $(t + 3) u_3(t)$

[Ans. d]

3. If Laplace transform of a function  $f(t)$  equals  $\frac{(e^{-2s} - e^{-s})}{s}$ , then

(a)  $f(t) = 1, t > 1$

(b)  $f(t) = 1$ , when  $1 < t < 2$  and 0 otherwise

(c)  $f(t) = -1$ , when  $1 < t < 3$  and 0 otherwise

(d)  $f(t) = -1$ , when  $1 < t < 2$  and 0 otherwise [Ans. d]

4. Inverse Laplace transform of 1 is

(a) 1

(b)  $\delta(t)$

(c)  $\delta(t - 1)$

(d)  $u(t)$

[Ans. d]

5. The inverse Laplace transform of  $\frac{ke^{-as}}{s^2 + k^2}$  is

(a)  $\sin kt$

(b)  $\cos kt$

(c)  $u(t - a) \sin kt$

(d) none of these

[Ans. d]

6. For  $L^{-1} \left[ \frac{1}{s^n} \right]$

(a)  $n > -1$

(b)  $n \geq 1$

(c)  $n = 1, 2, \dots$

(d)  $n < 1$

[Ans. c]

7.  $L\left[\frac{\sin t}{t}\right] =$

(a)  $\frac{1}{s^2 + 1}$  (b)  $\cot^{-1} s$

(c)  $\cot^{-1} (s - 1)$  (d)  $\tan^{-1} s$

[Ans. b]

8. Given  $L^{-1}\left[\frac{1}{(s^2 + a^2)}\right] = \frac{\sin at}{a}$ , then  $L^{-1}\left[\frac{s}{s^2 + a^2}\right] =$

(a)  $\cos at$  (b)  $\frac{\cos at}{a}$

(c)  $\left(\frac{\sin at}{a}\right)^2$  (d)  $\frac{\sin at}{a}$

[Ans. a]

9.  $L^{-1}\left[\frac{s e^{-3\pi}}{s^2 + 9}\right] =$

(a)  $\cos 3t u(t - \pi)$  (b)  $-\cos 3t u(t - \pi)$

(c)  $\cos 3t u\left(\frac{t - \pi}{3}\right)$  (d) none of these

[Ans. b]

10. The Laplace inverse of  $\sqrt{t}$  is

(a)  $\frac{\sqrt{\pi}}{\sqrt{s}}$  (b)  $\frac{1}{2} \frac{\sqrt{\pi}}{\sqrt{s}}$

(c)  $\frac{\sqrt{\pi}}{2s^2}$  (d) none of these

[Ans. c]

11. A function  $f(t)$  is said to be exponential order if

(a)  $f(t) = e^t$  (b)  $f(t) \cdot e^{kt} = 1$

(c)  $|f(t)| \leq be^{at}$  (d)  $|f(t)| > be^{at}$

[Ans. c]

12. The Laplace transform of a function  $f(t)$  exists of

(a) it is uniformly continuous

(b) it is piecewise continuous

(c) it is uniformly continuous and of exponential order

(d) it is piecewise continuous of exponential order

[Ans. d]

13. If  $L[f(t)] = \bar{f}(s)$ , then  $L[e^{-at}\bar{f}(t)]$  is

(a)  $-a\bar{f}(s)$  (b)  $\bar{f}(s - a)$

(c)  $e^{-as}\bar{f}(s)$  (d)  $\bar{f}(s + a)$

[Ans. d]



14. Inverse Laplace transform of  $(s + 2)^{-2}$  is

(a)  $t e^{-2t}$

(b)  $t e^{2t}$

(c)  $e^{2t}$

(d) none of these

[Ans. a]

15. Inverse Laplace transform of  $\frac{1}{(s^2 + 4s + 13)}$  is

(a)  $\frac{1}{2} e^{-3t} \sin 3t$

(b)  $\frac{1}{3} e^{-2t} \sin 3t$

(c)  $\frac{1}{4} e^{-2t} \sin 3t$

(d)  $\frac{1}{2} e^{3t} \sin 3t$

[Ans. b]

16. Laplace transform of  $f'(t)$  is

(a)  $s\bar{f}(s) - f(0)$

(b)  $s\bar{f}(s) + f(0)$

(c)  $s\bar{f}(s) - f(s)$

(d) none of these

[Ans. a]

17.  $L^{-1} \left[ \frac{1}{(s+3)^5} \right]$  is

(a)  $\frac{e^{-3t} t^4}{24}$

(b)  $\frac{e^{2t} t^2}{3}$

(c)  $\frac{e^{3t}}{24}$

(d) none of these

[Ans. a]

18.  $L^{-1} \left( \frac{1}{s^n} \right)$  is possible only when  $n$  is

(a) zero

(b)  $-ve$  integer

(c)  $+ve$  integer

(d) negative rational

[Ans. c]

19.  $L^{-1} \left[ \frac{s^2 + 3s + 7}{s^3} \right]$  is

(a)  $1 + 3t + \frac{7t^2}{2}$

(b)  $13t + \frac{t^2}{2}$

(c)  $1 - 3t + 7t^2$

(d) none of these

[Ans. a]

20. If  $L \{f(t)\} = \bar{f}(s)$ ; then  $L^{-1} \left\{ \frac{\bar{f}(s)}{s} \right\}$  is

(a)  $\int_0^t f(t) dt$

(b)  $\int_0^\infty e^{-st} f(t) dt$

(c)  $\int_0^\infty e^{-t} f(t) dt$

(d) none of these

[Ans. a]

21. If  $L^{-1} [\phi (s)] = f (t)$ , then  $L^{-1} [e^{-as} \phi (s)]$  is  
 (a)  $f (t + a) u (t - a)$  (b)  $f (t - a) u (t - a)$   
 (c)  $f (t - a)$  (d) none of these **[Ans. b]**
22.  $L^{-1} \left[ \frac{1}{s^2 + a^2} \right]$  is  
 (a)  $\frac{\sin at}{a}$  (b)  $\frac{\cos at}{a}$   
 (c)  $\frac{1}{s}$  (d) none of these **[Ans. a]**
23.  $L^{-1} \left[ \frac{\pi}{s^2 + \pi^2} \right]$  is  
 (a)  $\sin t$  (b)  $\sin \pi t$   
 (c)  $\cos \pi t$  (d) none of these **[Ans. b]**
24.  $L^{-1} \left[ \frac{s^2}{(s^2 + a^2)^2} \right]$  is  
 (a)  $\frac{1}{2a} (\sin at + at \cos at)$  (b)  $\frac{1}{2a} (\sin at - at \cos at)$   
 (c)  $\frac{1}{a} (\sin at - a \cos at)$  (d) none of these **[Ans. a]**
25. The inverse Laplace transform of  $\frac{1}{2s-7}$  is  
 (a)  $\frac{1}{2} e^{\frac{7}{2}s}$  (b)  $\frac{1}{2} e^{\frac{3}{2}s}$   
 (c)  $\frac{1}{2} e^{\frac{7}{2}t}$  (d) none of these **[Ans. c]**
26.  $L^{-1} \left[ \frac{s}{s^2 + 9} \right]$  is  
 (a)  $\cos 3t$  (b)  $\sin 3t$   
 (c)  $e^{-3t}$  (d) none of these **[Ans. a]**
27.  $L^{-1} \left[ \frac{s}{s^2 - a^2} \right]$  is  
 (a)  $\cos h at$  (b)  $\sin h at$   
 (c)  $\frac{1}{a} \sin at$  (d)  $e^{at} f (t)$  **[Ans. a]**

28.  $L^{-1} \left[ \frac{s}{s^2 + 1} \right]$  is

(a)  $\cos t$

(b)  $\sin t$

(c)  $\sin ht$

(d) none of these

[Ans. a]

29.  $L^{-1} \left[ \frac{1}{s^2 + 1} \right]$  is

(a)  $\cos t$

(b)  $\sin t$

(c)  $\cos ht$

(d) none of these

[Ans. b]

30.  $L^{-1} [F(s)]$  is

(a)  $\frac{-1}{t} L^{-1} \left[ \frac{d}{ds} F(s) \right]$

(b)  $L^{-1} \left[ \frac{d}{ds} F(s) \right]$

(c)  $-t L^{-1} [F(s)]$

(d) none of these

[Ans. a]

□□□

# MODEL QUESTION PAPER-I

06 MAT 21

## Second Semester B.E. Degree Examination Engineering Mathematics-II

Time : 3 hrs

Max. Marks : 100

- Note:** 1. Answer any five full questions selecting at least two questions from each part.  
2. Answer all objective type questions only in first and second writing pages.  
3. Answer for objective type questions shall not be repeated.

### PART A

1. (a) (i) Lagrange's mean value theorem is a special case of: (a) Rolle's theorem (b) Cauchy's mean value theorem (c) Taylor's theorem (d) Taylor's series. [Ans. b]  
(ii) The result, "If  $f'(x) = 0 \forall x$  in  $[a, b]$  then  $f(x)$  is a constant in  $[a, b]$ " can be obtained from: (a) Rolle's theorem (b) Lagrange's mean value theorem (c) Cauchy's mean value theorem (d) Taylor's theorem [Ans. b]  
(iii) The rate at which the curve is called: (a) Radius of curvature (b) Curvature (c) Circle curvature (d) Evolute [Ans. b]  
(iv) The radius of curvature of  $r = a \cos \theta$  at  $(r, \theta)$  is: (a)  $a$  (b)  $2a$  (c)  $1/2a$  (d)  $a^2$  [Ans. d] (04 marks)

- (b) Find the radius of curvature at the point  $\left(\frac{3a}{2}, \frac{3a}{2}\right)$  of the folium  $x^3 + y^3 = 3axy$ . [VTU, Jan. 2009] (04 marks)

**Solution.** Refer Unit I.

- (c) State and prove Cauchy's mean value theorem. [VTU, Jan. 2009] (06 marks)

**Solution.** Refer Unit I.

- (d) If  $f(x) = \log(1 + e^x)$ , using Maclaurin's theorem, show that

$$\log(1 + e^x) = \log 2 + \frac{x}{2} + \frac{x^2}{8} - \frac{x^4}{192} + \dots \quad \text{[VTU, Jan. 2008] (06 marks)}$$

2. (a) (i) The value of  $\lim_{x \rightarrow 0} \frac{1 - \cos x}{x \log(1+x)}$  is  
(a)  $1/2$  (b)  $1/4$   
(c)  $\infty$  (d) None of these. [Ans. a]  
(ii) The value of  $\lim_{x \rightarrow 0} (\cos x)^{1/x^2}$  is  
(a)  $\frac{-1}{2}$  (b)  $\frac{1}{\sqrt{e}}$   
(c)  $e$  (d)  $\sqrt{e}$ . [Ans. b]

(iii) The necessary conditions for  $f(x, y) = 0$  to have extremum are

(a)  $f_{xy} = 0, f_{yx} = 0$

(b)  $f_{xx} = 0, f_{yy} = 0,$

(c)  $f_x = 0, f_y = 0$

(d)  $f_x = 0, f_y = 0$  and  $f_{xx} > 0, f_{yy} > 0$ . [Ans. c]

(iv) The point  $(a, b)$  is called a stationary point and the value  $f(a, b)$  is called

(a) Stationary point

(b) Stationary value

(c) Maximum value

(d) Minimum value.

[Ans. b] (04 marks)

(b) Evaluate (i)  $\lim_{x \rightarrow 0} (\cos x)^{1/x^2}$ , (ii)  $\lim_{x \rightarrow 0} \left[ \frac{1}{\sin x} - \frac{1}{x} \right]$ . [VTU, Jan. 2009] (04 marks)

### Solution

(i) Let  $k = \lim_{x \rightarrow 0} (\cos x)^{1/x^2}$  [1<sup>∞</sup>] form

Taking logarithm on both sides, we get

$$\Rightarrow \log_e k = \lim_{x \rightarrow 0} \frac{\log(\cos x)}{x^2} \quad \left[ \frac{0}{0} \right] \text{ form}$$

Applying L' Hospital Rule,

$$\begin{aligned} \log_e k &= \lim_{x \rightarrow 0} \frac{-\sin x / \cos x}{2x} \\ &= \frac{-1}{2} \lim_{x \rightarrow 0} \frac{\tan x}{x} = \frac{-1}{2} \cdot 1 \quad \left( \because \lim_{x \rightarrow 0} \frac{\tan x}{x} = 1 \right) \end{aligned}$$

$$\begin{aligned} \log_e k &= \frac{-1}{2} \\ k &= e^{-1/2} \end{aligned}$$

Thus  $k = \frac{1}{\sqrt{e}}$

(ii) Let  $k = \lim_{x \rightarrow 0} \left[ \frac{1}{\sin x} - \frac{1}{x} \right]$  [ $\infty - \infty$ ] form

$$= \lim_{x \rightarrow 0} \left[ \frac{x - \sin x}{x \sin x} \right] \quad \left[ \frac{0}{0} \right] \text{ form}$$

By L' Hospital Rule

$$= \lim_{x \rightarrow 0} \left[ \frac{1 - \cos x}{x \cos x + \sin x} \right] \quad \left[ \frac{0}{0} \right] \text{ form}$$

Again Applying L' Hospital Rule

$$= \lim_{x \rightarrow 0} \left[ \frac{\sin x}{-x \sin x + \cos x + \cos x} \right] = \frac{0}{0+2} = 0$$

Thus  $k = 0$ .

(c) Expand  $f(x, y) = \tan^{-1}(y/x)$  in powers of  $(x - 1)$  and  $(y - 1)$  upto second degree terms.  
 [VTU, Jan. 2009] (06 marks)

**Solution.** Refer Unit II.

(d) Discuss the maxima and minima of  $f(x, y) = x^3 y^2 (1 - x - y)$   
 [VTU, Jan. 2009] (06 marks)

**Solution.** Refer Unit II.

3. a. (i)  $\int_0^1 \int_{x^2}^{2-x} xy \, dx \, dy$  is equal to:

- (a)  $\frac{3}{4}$  (b)  $\frac{3}{8}$
- (c)  $\frac{3}{5}$  (d)  $\frac{3}{7}$ .

[Ans. b]

(ii)  $\int_0^1 \int_0^{1-x} dx \, dy$  represents .....

- (a) Area of the triangle vertices (0, 0), (0, 1), (1, 0)
- (b) Area of the triangle vertices (0, 0), (0, 1)
- (c) Both (a) and (b)
- (d) None of these.

[Ans. a]

(iii)  $\beta\left[\frac{1}{2}, \frac{1}{2}\right] = \dots\dots\dots$

- (a) 3.1416 (b) 2.1416
- (c) 1.1416 (d) 4.236.

[Ans. a]

(iv)  $\int_0^2 \int_1^3 \int_1^2 xy^2 z \, dz \, dy \, dx = \dots\dots\dots$

- (a) 28 (b) 26
- (c) 30 (d) 42.

[Ans. b] (04 marks)

(b) Evaluate the integral by changing the order of integration,  $\int_0^\infty \int_0^x xe^{-x^2/y} dy \, dx$ .

[VTU, Jan. 2009] (04 marks)

**Solution**  $I = \int_{x=0}^\infty \int_{y=0}^x xe^{-x^2/y} dy \, dx$

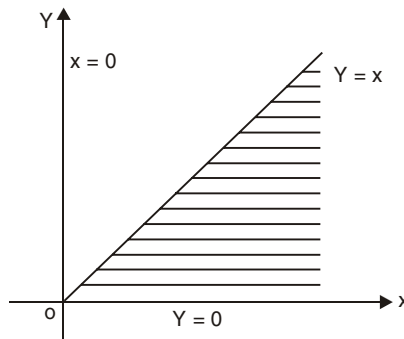

The region is as shown in the figure. On changing the order of integration we must have  $y = 0$  to  $\infty$ ,  $x = y$  to  $\infty$

$$I = \int_{y=0}^{\infty} \int_{x=y}^{\infty} x e^{-x^2/y} dx dy$$

Put  $\frac{x^2}{y} = t \quad \therefore \frac{2x}{y} dx = dt$

$$x dx = y dt/2$$

Also when  $x = y, \quad t = y$  and

When  $x = \infty, \quad t = \infty$

$$\begin{aligned} \therefore I &= \int_{y=0}^{\infty} \int_{t=y}^{\infty} e^{-t} \frac{y}{2} dt dy \\ &= \int_{y=0}^{\infty} \frac{y}{2} [e^{-t}]_{t=y}^{\infty} dy \\ &= \frac{1}{2} \int_{y=0}^{\infty} y e^{-y} dy \end{aligned}$$

Applying Bernoulli's rule,

$$\begin{aligned} &= \frac{1}{2} \left\{ [y(-e^{-y})]_{y=0}^{\infty} - [(1)(e^{-y})]_{y=0}^{\infty} \right\} \\ &= \frac{1}{2} [0 - (0 - 1)] \\ I &= \frac{1}{2} \end{aligned}$$

(c) Find the volume of the sphere  $x^2 + y^2 + z^2 = a^2$  using triple integration

[VTU, Jan. 2009] (06 marks)

**Solution.** Here, it is convenient to employ spherical polar coordinates  $(r, \theta, \phi)$ . In terms of these coordinates, the equation of the given sphere is  $r^2 = a^2$  or  $r = a$ .

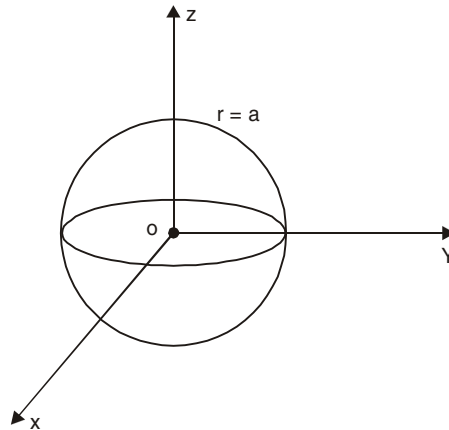

In this sphere,

$r$  varies from 0 to  $a$ ,

$\theta$  varies from 0 to  $\pi$  and

$\phi$  varies from 0 to  $2\pi$ .

Hence, the required volume is

$$\begin{aligned} V &= \iiint_V r^2 \sin \theta \, dr \, d\theta \, d\phi \\ &= \int_{r=0}^a \int_{\theta=0}^{\pi} \int_{\phi=0}^{2\pi} r^2 \sin \theta \, dr \, d\theta \, d\phi \\ &= \int_0^a r^2 \, dr \times \int_0^{\pi} \sin \theta \, d\theta \times \int_0^{2\pi} d\phi \\ &= \frac{1}{3} a^3 \times (-\cos \pi + \cos 0) \times 2\pi \\ &= \frac{4\pi}{3} a^3. \end{aligned}$$

(d) Express the following integrals in terms of Gamma functions.

[VTU, Jan. 2009] (06 marks)

$$(i) \int_0^1 \frac{dx}{\sqrt{1-x^4}}$$

$$(ii) \int_0^{\infty} \frac{x^c}{c^x} dx$$

**Solution**

$$\Rightarrow (i) \quad I = \int_0^1 \frac{dx}{\sqrt{1-x^4}}$$

$$\text{Put} \quad x^2 = \sin \theta, \quad \text{i.e.,} \quad x = \sin^{1/2} \theta$$

$$\text{So that} \quad dx = \frac{1}{2} \sin^{-1/2} \theta \cos \theta \, d\theta$$

$$\text{When} \quad x = 0, \quad \theta = 0$$

$$\text{When} \quad x = 1, \quad \theta = \frac{\pi}{2}$$

$$\therefore \quad I = \int_0^{\pi/2} \frac{1}{2} \cdot \frac{\sin^{-1/2} \theta \cos \theta \, d\theta}{\sqrt{1-\sin^2 \theta}}$$

$$= \frac{1}{2} \int_0^{\pi/2} \sin^{-1/2} \theta \, d\theta$$

$$= \frac{1}{2} \frac{\sqrt{\pi}}{2} \cdot \frac{\Gamma\left[-\frac{1}{2}+1\right]}{\Gamma\left[\frac{-\frac{1}{2}+2}{2}\right]}$$



$$= \frac{\sqrt{\pi}}{4} \cdot \frac{\Gamma\left(\frac{1}{4}\right)}{\Gamma\left(\frac{3}{4}\right)}$$

$$(ii) \quad I = \int_0^{\infty} \frac{x^c}{c^x} dx$$

$$= \int_0^{\infty} \frac{x^c}{e^{x \log c}} dx$$

$$I = \int_0^{\infty} e^{-x \log c} x^c dx$$

Put  $x \log c = t$  so that  $dx = \frac{dt}{\log c}$

$$x = \frac{t}{\log c}$$

$$\therefore I = \int_0^{\infty} e^{-t} \left( \frac{t}{\log c} \right)^c \frac{dt}{\log c}$$

$$= \frac{1}{(\log c)^{c+1}} \int_0^{\infty} t^c e^{-t} dt$$

$$= \frac{\Gamma(c+1)}{(\log c)^{c+1}}$$

4. (a) (i) If  $\vec{F}(t)$  has a constant magnitude then:

$$(a) \frac{d}{dt} \vec{F}(t) = 0$$

$$(b) \vec{F}(t) \cdot \frac{d\vec{F}(t)}{dt} = 0$$

$$(c) \vec{F}(t) \times \frac{d\vec{F}(t)}{dt} = 0$$

$$(d) \vec{F}(t) - \frac{d\vec{F}(t)}{dt} = 0 \quad [\text{Ans. } b]$$

(ii) Use the following integral work done by a force  $\vec{F}$  can be calculated:

(a) Line integral

(b) Surface integral

(c) Volume integral

(d) None of these. [Ans. a]

(iii) Green's theorem in the plane is applicable to:

(a)  $xy$ -plane

(b)  $yz$ -plane

(c)  $zx$ -plane

(d) All of these. [Ans. d]

(iv) If all the surfaces are closed in a region containing volume  $V$  then the following theorem is applicable:

(a) Stoke's theorem

(b) Green's theorem

(c) Gauss Divergence theorem

(d) Only (a) and (b). (04 marks) [Ans. c]

- (b) Use the line integral, compute work done by a force  $\vec{F} = (2y + 3) \vec{i} + xz \vec{j} + (yz - x) \vec{k}$  when it moves a particle from the point (0, 0, 0) to the point (2, 1, 1) along the curve  $x = 2t^2, y = t, z = t^3$ . [VTU, Jan. 2009] (04 marks)

**Solution.** Refer Unit IV.

- (c) Verify Green's theorem for  $\int_c [(xy + y^2) dx + x^2 dy]$  where  $c$  is bounded by  $y = x$  and  $y = x^2$  [VTU, Jan. 2009] (06 marks)

**Solution.** Refer Unit IV.

- (d) Prove that the cylindrical coordinate system is orthogonal. [VTU, Jan. 2009] (06 marks)

**Solution.** Refer Unit IV.

**PART B**

5. (a) (i) The differential equation  $\frac{dy}{dx} = y^2$  is:  
 (a) Linear (b) Non-linear (c) Quasilinear (d) None of these [Ans. b]

- (ii) The particular integral of  $\frac{d^2y}{dx^2} + y = \cos x$  is:  
 (a)  $\frac{1}{2} \sin x$  (b)  $\frac{1}{2} \cos x$  (c)  $\frac{1}{2} x \cos x$  (d)  $\frac{1}{2} x \sin x$  [Ans. d]

- (iii) The general solution of the D.E.  $(D^2 + 1)^2 y = 0$  is:  
 (a)  $c_1 \cos x + c_2 \sin x$   
 (b)  $(c_1 + c_2 x) \cos x + (c_3 + c_4 x) \sin x$   
 (c)  $c_1 \cos x + c_2 \sin x + c_3 \cos x + c_4 \sin x$   
 (d)  $(c_1 \cos x + c_2 \sin x) (c_3 \cos x + c_4 \sin x)$  [Ans. b]

- (iv) The set of linearly independent solution of the D.E.  $\frac{d^4y}{dx^4} - \frac{d^2y}{dx^2} = 0$  is:  
 (a)  $\{1, x, e^x, e^{-x}\}$  (b)  $\{1, x, e^{-x}, xe^{-x}\}$   
 (c)  $\{1, x, e^x, xe^x\}$  (d)  $\{1, x, e^x, xe^{-x}\}$  [Ans. a] (04 marks)

- (b) Solve  $\frac{d^3y}{dx^3} + 2 \frac{d^2y}{dx^2} + \frac{dy}{dx} = e^{-x} + \sin 2x$  [VTU, July, 2008] (04 marks)

**Solution.** Here, the A.E. is  $m^3 + 2m^2 + m = 0$

$\Rightarrow m(m^2 + 2m + 1) = 0$

$\Rightarrow m(m + 1)^2 = 0$

whose roots are 0, -1, -1

$\therefore$  C.F. =  $C_1 e^{0x} + (C_2 + C_3 x) e^{-x}$

$\therefore$  C.F. =  $C_1 + (C_2 + C_3 x) e^{-x}$

$$\begin{aligned} \text{Also} \quad \text{P.I.} &= \frac{1}{D^3 + 2D^2 + D} (e^{-x} + \sin 2x) \\ &= \frac{e^{-x}}{D^3 + 2D^2 + D} + \frac{\sin 2x}{D^3 + 2D^2 + D} \\ \text{P.I.} &= \text{P.I.}_1 + \text{P.I.}_2 \end{aligned}$$

$$\begin{aligned} \therefore \quad \text{P.I.}_1 &= \frac{e^{-x}}{D^3 + 2D^2 + D} && (D \rightarrow -1) \\ &= \frac{e^{-x}}{(-1)^3 + 2(-1)^2 + (-1)} && (Dr = 0) \end{aligned}$$

Diefferentiate the denominator and multiply 'x', we get

$$\begin{aligned} \therefore \quad \text{P.I.}_1 &= \frac{xe^{-x}}{3D^2 + 4D + 1} && (D \rightarrow -1) \\ &= \frac{xe^{-x}}{3(-1)^2 + 4(-1) + 1} && (Dr = 0) \end{aligned}$$

Again differentiate and multiply x.

$$\begin{aligned} \therefore \quad \text{P.I.}_1 &= \frac{x^2 e^{-x}}{6D + 4} && (D \rightarrow -1) \\ \text{P.I.}_1 &= \frac{x^2 e^{-x}}{-2} \end{aligned}$$

$$\begin{aligned} \Rightarrow \quad \text{P.I.}_2 &= \frac{\sin 2x}{D^3 + 2D^2 + D} && (D^2 \rightarrow -2^2 = -4) \\ &= \frac{\sin 2x}{-4D - 8 + D} \\ &= \frac{\sin 2x}{-3D - 8} \\ &= -\frac{\sin 2x}{3D + 8} \times \frac{3D - 8}{3D - 8} \\ &= -\frac{(6 \cos 2x - 8 \sin 2x)}{9D^2 - 64} && (D^2 \rightarrow -2^2) \end{aligned}$$

$$\therefore \quad \text{P.I.}_2 = \frac{1}{100} (6 \cos 2x - 8 \sin 2x)$$

\(\therefore\) The general solution is

$$y = \text{C.F.} + \text{P.I.}$$

$$y = C_1 + (C_2 + C_3 x) e^{-x} - \frac{1}{2} x^2 e^{-x} + \frac{1}{50} (3 \cos 2x - 4 \sin 2x)$$

(c) Solve  $\frac{d^2y}{dx^2} - 4y = \cos h(2x - 1) + 3^x$  [VTU, Jan. 2009] (06 marks)

**Solution.** We have

$$(D^2 - 4)y = \cos h(2x - 1) + 3^x$$

A.E. is  $m^2 - 4 = 0$  or  $(m - 2)(m + 2) = 0$

$\Rightarrow m = 2, -2$

$\therefore$  C.F. =  $C_1 e^{2x} + C_2 e^{-2x}$

$$\text{P.I.} = \frac{\cos h(2x - 1) + 3^x}{D^2 - 4}$$

$$= \frac{1}{2} \left[ \frac{e^{2x-1}}{D^2 - 4} + \frac{e^{-(2x-1)}}{D^2 - 4} \right] + \frac{3^x}{D^2 - 4}$$

$$= \text{P.I.}_1 + \text{P.I.}_2 + \text{P.I.}_3$$

$$\text{P.I.}_1 = \frac{1}{2} \frac{e^{2x-1}}{D^2 - 4} = \frac{1}{2} \frac{e^{2x-1}}{2^2 - 4} \quad (Dr = 0)$$

$$= \frac{1}{2} \frac{x e^{2x-1}}{2D} = \frac{1}{2} \frac{x e^{2x-1}}{4} = \frac{1}{8} x e^{2x-1}$$

$$\text{P.I.}_2 = \frac{1}{2} \frac{e^{-(2x-1)}}{D^2 - 4} \quad (D \rightarrow -2)$$

$$= \frac{1}{2} \frac{e^{-(2x-1)}}{(-2)^2 - 4} \quad (Dr = 0)$$

$$= \frac{1}{2} \frac{x e^{-(2x-1)}}{2D} \quad (D \rightarrow -2)$$

$$\text{P.I.}_2 = \frac{-x}{8} e^{-(2x-1)}$$

$$\text{P.I.}_3 = \frac{3^x}{D^2 - 4} = \frac{e^{(\log 3)^x}}{D^2 - 4} \quad (D \rightarrow \log 3)$$

$$= \frac{e^{(\log 3)^x}}{(\log 3)^2 - 4}$$

$$= \frac{3^x}{(\log 3)^2 - 4}$$

Complete solution:

$$y = \text{C.F.} + \text{P.I.}$$

$$= C_1 e^{2x} + C_2 e^{-2x} + \frac{x}{8} e^{2x-1} - \frac{x}{8} e^{-(2x-1)} + \frac{3^x}{(\log 3)^2 - 4}$$

(d) Solve by the method of undetermined coefficients;  $(D^2 + 1)y = \sin x$ .

[VTU, July 2008] (06 marks)

**Solution.** Refer Unit V.

6. (a) (i) The homogeneous linear differential equation whose auxillary equation has roots 1, 1 and  $-2$  is:

$$(a) (D^3 + D^2 + 2D + 2)y = 0 \quad (b) (D^3 + 3D - 2)y = 0$$

$$(c) (D^3 - 3D + 2)y = 0 \quad (d) (D + 1)^2 (D - 2)y = 0 \quad [\text{Ans. c}]$$

- (ii) The general solution of  $(x^2 D^2 - xD)y = 0$  is :

$$(a) y = C_1 + C_2 e^x \quad (b) y = C_1 + C_2 x$$

$$(c) y = C_1 + C_2 x^2 \quad (d) y = C_1 x + C_2 x^2 \quad [\text{Ans. c}]$$

- (iii) Every solution of  $y'' + ay' + by = 0$  where  $a$  and  $b$  are constants approaches to zero as  $x \rightarrow \infty$  provided.

$$(a) a > 0, b > 0 \quad (b) a > 0, b < 0$$

$$(c) a < 0, b < 0 \quad (d) a < 0, b > 0 \quad [\text{Ans. a}]$$

- (iv) By the method of variation of parameters the  $W$  is called.

$$(a) \text{Work done} \quad (b) \text{Wronskian}$$

$$(c) \text{Euler's} \quad (d) \text{None of these} \quad [\text{Ans. b}] \text{ (04 marks)}$$

(b) Solve  $(1 + x)^2 y'' + (1 + x)y' + y = 2 \sin [\log (1 + x)]$ .

[VTU, Jan. 2009] (04 marks)

**Solution**

Put  $t = \log (1 + x)$  or  $e^t = 1 + x$

Then we have

$$(1 + x) \frac{dy}{dx} = 1 \cdot Dy$$

$$(1 + x)^2 \frac{d^2 y}{dx^2} = 1^2 \cdot D(D - 1)y$$

Hence the given D.E. becomes

$$[D(D - 1)y + D + 1]y = 2 \sin t$$

$$\text{i.e., } (D^2 + 1)y = 2 \sin t$$

$$\text{A.E. is } m^2 + 1 = 0 \Rightarrow m = \pm i$$

$$\therefore \text{C.F.} = C_1 \cos t + C_2 \sin t$$

$$\text{P.I.} = \frac{2 \sin t}{D^2 + 1} \quad (D^2 \rightarrow -1^2 = -1)$$

$$= \frac{2 \sin t}{-1 + 1} \quad (Dr = 0)$$

$$= \frac{2 \sin t}{2D} \times \frac{2D}{2D}$$

$$= \frac{4 \cos t}{4D^2} \quad (D^2 \rightarrow -1^2 = -1)$$

$$= \frac{4 \cos t}{-4}$$

∴ P.I. =  $-\cos t$

∴ The complete solution is  $y = \text{C.F.} + \text{P.I.}$

$$y = C_1 \cos t + C_2 \sin t - \cos t$$

where  $t = \log(1 + x)$

$$y = C_1 \cos [\log(1 + x)] + C_2 \sin [\log(1 + x)] - \cos [\log(1 + x)]$$

(c) Solve  $x^3 \frac{d^3 y}{dx^3} + 2x^2 \frac{d^2 y}{dx^2} + 2y = 10 \left( x + \frac{1}{x} \right)$ . [VTU, Jan. 2009] (06 marks)

**Solution.** Refer Unit VI.

(d) Solve, by the method of variation of parameters  $\frac{d^2 y}{dx^2} + y = \tan x$ .

**Solution.** Refer Unit VI.

7. (a) (i) The Laplace transform of  $t^2 e^t$  is :

(a)  $\frac{2}{(s-2)^2}$

(b)  $\frac{2}{(s-2)^3}$

(c)  $\frac{1}{(s-2)^3}$

(d)  $\frac{1}{(s-1)^3}$

[Ans. b]

(ii)  $L[e^{-t} \sin ht]$  is:

(a)  $\frac{1}{(s+1)^2 + 1}$

(b)  $\frac{1}{(s-1)^2 + 1}$

(c)  $\frac{1}{s(s+2)}$

(d)  $\frac{s-1}{(s-1)^2 + 1}$

[Ans. c]

(iii)  $L[e^{-3t} \cos 3t] =$

(a)  $\frac{s-3}{s^2 - 6s - 18}$

(b)  $\frac{s+3}{s^2 + 6s + 18}$

(c)  $\frac{s+3}{s^2 - 6s + 18}$

(d)  $\frac{s-3}{s^2 + 6s - 18}$

[Ans. b]

(iv)  $L\left[\frac{\sin t}{t}\right] =$

(a)  $\frac{1}{s^2 + 1}$

(b)  $\cot^{-1} s$

(c)  $\cot^{-1}(s - 1)$

(d)  $\tan^{-1} s$

[Ans. b] (04 marks)

(b) Find the Laplace transform of

$$2^t + \frac{\cos 2t - \cos 3t}{t}$$

[VTU, Jan. 2009] (04 marks)

**Solution.** Refer Unit VII.

Put  $a = 2, b = 3$

$$\text{Ans. } \frac{1}{s - \log 2} + \frac{1}{2} \log \frac{s^2 + 3^2}{s^2 + 2^2}$$

(c) Find the Laplace transform of the periodic function with period  $\frac{2\pi}{w}$

$$f(t) = \begin{cases} \sin wt, & 0 < t < \frac{\pi}{w} \\ 0, & \frac{\pi}{w} < t < \frac{2\pi}{w} \end{cases}$$

[VTU, Jan. 2009] (06 marks)

**Solution.** Refer Unit VII.

$$(d) \text{ Express } f(t) = \begin{cases} \cos t, & 0 < t < \pi \\ \cos 2t, & \pi < t < 2\pi \\ \cos 3t, & t > 2\pi \end{cases}$$

[VTU, Jan. 2009] (06 marks)

**Solution.**  $f(t) = \cos t + (\cos 2t - \cos t) u(t - \pi) + (\cos 3t - \cos 2t) u(t - 2\pi)$

$$L[f(t)] = L(\cos t) + L[(\cos 2t - \cos t) u(t - \pi)] +$$

$$L[(\cos 3t - \cos 2t) u(t - 2\pi)] \quad \dots(1)$$

Let  $F(t - \pi) = \cos 2t - \cos t$

$$G(t - 2\pi) = \cos 3t - \cos 2t$$

$$\Rightarrow F(t) = \cos 2(t + \pi) - \cos(t + \pi)$$

$$\text{and } G(t) = \cos 3(t + 2\pi) - \cos 2(t + 2\pi)$$

$$\text{i.e., } F(t) = \cos 2t + \cos t$$

$$G(t) = \cos 3t - \cos 2t$$

$$\therefore \bar{F}(s) = \frac{s}{s^2 + 4} + \frac{s}{s^2 + 1}$$

$$\bar{G}(s) = \frac{s}{s^2 + 9} - \frac{s}{s^2 + 4}$$

$$\text{But } L[F(t - \pi) u(t - \pi)] = e^{-\pi s} \bar{F}(s)$$

$$\text{and } L[G(t - 2\pi) u(t - 2\pi)] = e^{-2\pi s} \bar{G}(s)$$

$$\text{i.e., } L[(\cos 2t - \cos t) u(t - \pi)] = e^{-\pi s} \left[ \frac{s}{s^2 + 4} + \frac{s}{s^2 + 1} \right]$$

$$\text{and } L[(\cos 3t - \cos 2t) u(t - 2\pi)] = e^{-2\pi s} \left[ \frac{s}{s^2 + 9} - \frac{s}{s^2 + 4} \right]$$

Hence (1) becomes

$$L[f(t)] = \frac{s}{s^2+1} + e^{-\pi s} \left[ \frac{s}{s^2+4} + \frac{s}{s^2+1} \right] + e^{-2\pi s} \left[ \frac{s}{s^2+9} - \frac{s}{s^2+4} \right]$$

Thus 
$$L[f(t)] = \frac{s}{s^2+1} + s e^{-\pi s} \left[ \frac{1}{s^2+4} + \frac{1}{s^2+1} \right] - \frac{5s e^{-2\pi s}}{(s^2+4)(s^2+9)}$$

8. (a) (i) Given  $L^{-1} \left[ \frac{1}{s^2+a^2} \right] = \frac{\sin at}{a}$  then  $L^{-1} \left[ \frac{s}{s^2+a^2} \right]$  is:

(a)  $\cos at$

(b)  $\frac{\cos at}{a}$

(c)  $\left( \frac{\sin at}{a} \right)^2$

(d)  $\frac{\sin at}{a}$

[Ans. a]

(ii)  $L^{-1} \left[ \frac{e^{-s}}{s^3} \right]$  is:

(a)  $u(t-1) \frac{(t-1)^2}{2}$

(b)  $u(t-1) \frac{(t-1)^3}{6}$

(c)  $u(t) \frac{t^2}{2}$

(d) None of these

[Ans. a]

(iii)  $L^{-1} \left[ \frac{s e^{-s\pi}}{s^2+9} \right]$  is:

(a)  $\cos 3t u(t-\pi)$

(b)  $-\cos 3t u(t-\pi)$

(c)  $\cos 3t u(t-\pi)/3$

(d)  $e^{-as} L[f(t-a)]$

[Ans. b]

(iv) The Laplace inverse of  $\sqrt{t}$  is:

(a)  $\frac{\sqrt{\pi}}{\sqrt{s}}$

(b)  $\frac{1}{2} \frac{\sqrt{\pi}}{\sqrt{s}}$

(c)  $\frac{\sqrt{\pi}}{2s^{3/2}}$

(d) Does not exist

[Ans. c] (04 marks)

(b) Find  $L^{-1} \left[ \log \left( \frac{s+a}{s+b} \right) \right]$ .

[VTU, Jan. 2009] (04 marks)

**Solution.** Let  $\bar{F}(s) = \log \left( \frac{s+a}{s+b} \right) = \log(s+a) - \log(s+b)$



$$-\bar{F}'(s) = -\left\{ \frac{1}{s+a} - \frac{1}{s+b} \right\}$$

$$\text{Now } L^{-1}[-\bar{F}'(s)] = L^{-1}\left[\frac{1}{s+b}\right] - L^{-1}\left[\frac{1}{s+a}\right]$$

$$\text{i.e., } t f(t) = e^{-bt} - e^{-at}$$

$$\text{Thus, } f(t) = \frac{e^{-bt} - e^{-at}}{t}.$$

$$(c) \text{ Apply Convolution theorem to evaluate } L^{-1}\left[\frac{s}{(s^2 + a^2)^2}\right].$$

[VTU, Jan. 2009] (06 marks)

**Solution.** Refer Unit VIII.

(d) Solve the differential equation by Laplace transform method,  $y'' + 4y' + 3y = e^{-t}$  and the initial conditions  $y(0) = y'(0) = 1$ . [VTU, Jan. 2009] (06 marks)

**Solution.** Refer Unit VIII.

□□□

# MODEL QUESTION PAPER-II

06 MAT 21

## Second Semester B.E. Degree Examination Engineering Mathematics-II

Time : 3 hrs

Max. Marks : 100

- Note:** 1. Answer any five full questions selecting at least two questions from each part.  
2. Answer all objective type questions only in first and second writing pages.  
3. Answer for objective type questions shall not be repeated.

### PART A

1. (a) (i) The radius of curvature of  $y = e^{-x^2}$  at  $(0, 1)$  is  
(a) 1 (b) 2  
(c)  $\frac{1}{2}$  (d)  $\frac{1}{3}$  [Ans. c]
- (ii) The radius of curvature of the circle of curvature is  
(a) 1 (b)  $\rho$   
(c)  $\frac{1}{\rho}$  (d)  $\rho^2$  [Ans. b]
- (iii) The first three non-zero terms in the expansion of  $e^x \tan x$  is  
(a)  $x + x^2 + \frac{1}{3}x^3$  (b)  $x + \frac{x^3}{3} + \frac{2}{5}x^5$   
(c)  $x + x^2 + \frac{5}{6}x^3$  (d)  $x + \frac{x^3}{3} + \frac{1}{6}x^5$  [Ans. c]
- (iv) The radius of curvature  $r = a \sin \theta$  at  $(r, \theta)$  is  
(a) 1 (b) 0  
(c) 2 (d) None of these [Ans. d] (04 marks)
- (b) Find the radius of curvature at  $x = \frac{\pi a}{4}$  on  $y = a \sec\left(\frac{x}{a}\right)$ .

[VTU, July 2008] (04 marks)

**Solution.** Refer Unit I.

- (c) Verify Rolle's theorem for the function  $f(x) = (x - a)^m (x - b)^n$  in  $[a, b]$  where  $m > 1$  and  $n > 1$ . [VTU, Jan. 2008] (06 marks)

**Solution.** Refer Unit I.

- (d) Expand  $e^{\sin x}$  up to the term containing  $x^4$  by Maclaurin's theorem. [VTU, Jan. 2008] (06 marks)

**Solution.** Refer Unit I.

2. (a) (i) The value of  $\lim_{x \rightarrow 0} x \log x$  is
- (a) 1 (b) 0  
(c) 2 (d)  $\infty$  [Ans. b]
- (ii) The value of  $\lim_{x \rightarrow a} \log \left[ 2 - \left( \frac{x}{a} \right) \right] \cot(x - a)$  is
- (a)  $\frac{-1}{a}$  (b) 1  
(c) 2 (d) None of these [Ans. a]
- (iii) If  $f(x, y)$  has derivatives upto any order with in a neighbourhood of a point  $(a, b)$  then  $f(x, y)$  can be extended to the
- (a) Finite series (b) Infinite series  
(c) Some extension limits (d) None of these [Ans. b]
- (iv) If  $AC - B^2 < 0$  then  $f$  has neither a maximum nor a minimum at  $(a, b)$  the point  $(a, b)$  is called :
- (a) Saddle point (b) Maximum at  $(a, b)$   
(c) Minimum at  $(a, b)$  (d) Both (a) and (b) [Ans. a] (04 marks)

(b) Evaluate  $\lim_{x \rightarrow 0} \left( \frac{1}{x^2} - \cot^2 x \right)$ . [VTU, Jan. 2005] (04 marks)

**Solution.** Refer Unit II.

(c) Expand  $e^x \log(1 + y)$  by Maclaurin's theorem up to the third degree term.  
[VTU, Jan. 2008] (06 marks)

**Solution.** Refer Unit II.

(d) Determine the maxima/minima of the function  $\sin x + \sin y + \sin(x + y)$ .  
[VTU, Jan. 2005] (06 marks)

**Solution.** Refer Unit II.

3. (a) (i) For  $\int_0^\infty \int_x^\infty f(x, y) dx dy$ , the change of order is
- (a)  $\int_x^\infty \int_0^\infty f(x, y) dx dy$  (b)  $\int_0^\infty \int_x^\infty f(x, y) dx dy$   
(c)  $\int_0^\infty \int_0^y f(x, y) dx dy$  (d)  $\int_0^\infty \int_0^x f(x, y) dx dy$  [Ans. c]
- (ii) The value of the integral  $\int_{-2}^2 \frac{dx}{x^2}$  is
- (a) 0 (b) 0.25  
(c) 1 (d)  $\infty$  [Ans. d]
- (iii) The volume of the tetrahedron bounded by the coordinate planes and the plane  $\frac{x}{a} + \frac{y}{b} + \frac{z}{c} = 1$  is

(a)  $\frac{abc}{2}$

(b)  $\frac{abc}{3}$

(c)  $\frac{abc}{6}$

(d)  $\frac{24}{abc}$

[Ans. c]

(iv)  $\frac{\Gamma(7)}{\Gamma(5)}$  is

(a) 30

(b) 42

(c) 48

(d) 17

[Ans. a] (04 marks)

(b) Find the value of  $\iint xy(x+y) dx dy$  taken over the region enclosed by the curve  $y = x$  and  $y = x^2$ . [VTU, Jan. 2008, July 2008] (04 marks)

**Solution.** Refer Unit III.

(c) Using the multiple integrals find the volume of the ellipsoid  $\frac{x^2}{a^2} + \frac{y^2}{b^2} + \frac{z^2}{c^2} = 1$ .

[VTU, Jan. 2008] (06 marks)

**Solution.** Refer Unit III.

(d) With usual notation show that  $\beta(m, n) = \frac{\Gamma(m) \cdot \Gamma(n)}{\Gamma(m+n)}$  [VTU, Jan, 2008] (06 marks)

4. (a) (i) If all the surfaces are enclosed in a region containing volume  $V$  then the following theorem is applicable.

(a) Stoke's theorem

(b) Green's theorem

(c) Gauss divergence theorem

(d) Only (a) and (b)

[Ans. c]

(ii) The component of  $\nabla\phi$  in the direction of a unit vector  $\vec{a}$  is  $\nabla\phi \cdot \vec{a}$  and is called

(a) The directional derivative of  $\phi$  in the direction  $\vec{a}$ .

(b) The magnitude of  $\phi$  in the direction  $\vec{a}$ .

(c) The normal of  $\phi$  in the direction  $\vec{a}$ .

(d) None of these

[Ans. a]

(iii) For a vector function  $\vec{F}$ , there exists a scalar potential only when

(a)  $\text{div } \vec{F} = 0$

(b)  $\text{grad}(\text{div } \vec{F}) = 0$

(c)  $\text{curl } \vec{F} = 0$

(d)  $\vec{F} \cdot \text{curl } \vec{F} = 0$

[Ans. c]

(iv) Which of the following is true:

(a)  $\text{curl}(\vec{A} \cdot \vec{B}) = \text{curl } \vec{A} + \text{curl } \vec{B}$

(b)  $\text{div curl } \vec{A} = \nabla \vec{A}$

$$(c) \operatorname{div} (\vec{A} \cdot \vec{B}) = \operatorname{div} \vec{A} \operatorname{div} \vec{B}$$

$$(d) \operatorname{div} \operatorname{cur} \vec{A} = 0$$

[Ans. d] (04 marks)

- (b) Evaluate  $\int_0^c \vec{F} \cdot d\vec{r}$  where  $\vec{F} = x^2 i + y^2 j + z^2 k$  and  $c$  is given by  $x = \cos t$ ,  $y = \sin t$ ,  $z = t$ ,  $0 \leq t \leq \pi$ .

[VTU, Jan. 2006] (04 marks)

**Solution.** Refer Unit IV.

- (c) Evaluate  $\int (xy - x^2) dx + x^2 y dy$  where  $c$  is the closed formed by  $y = 0$ ,  $x = 1$  and  $y = x$  (a) directly as a line integral (b) by employing Green's theorem.

[VTU, Jan. 2007] (06 marks)

**Solution.** Refer Unit IV.

- (d) If  $f$  and  $g$  are continuously differentiable show that  $\nabla f \times \nabla g$  is a solenoidal.

**Solution.** Refer Unit IV.

## PART B

5. (a) (i) The general solution of the differential equation  $(D^4 - 6D^3 + 12D^2 - 8D) y = 0$  is

$$(a) y = c_1 + [c_2 + c_3 x + c_4 x^2] e^{2x}$$

$$(b) y = (c_1 + c_2 x + c_3 x^2) e^{2x}$$

$$(c) y = c_1 + c_2 x + c_3 x^2 + c_4 x^4$$

$$(d) y = c_1 + c_2 x + c_3 x^2 + c_4 e^{2x}$$

[Ans. a]

- (ii) The particular integral of  $\frac{d^2 y}{dx^2} + \frac{dy}{dx} = x^2 + 2x + 4$  is

$$(a) \frac{x^2}{3} + 4x$$

$$(b) \frac{x^3}{3} + 4$$

$$(c) \frac{x^3}{3} + 4x$$

$$(d) \frac{x^3}{3} + 4x^2$$

[Ans. c]

- (iii) The particular integral of  $(D^2 + a^2) y = \sin ax$  is

$$(a) \frac{-x}{2a} \cos ax$$

$$(b) \frac{x}{2a} \cos ax$$

$$(c) \frac{-ax}{2} \cos ax$$

$$(d) \frac{ax}{2} \cos ax$$

[Ans. a]

- (iv) The solution of the differential equation  $(D^2 - 2D + 5)^2 y = 0$  is

$$(a) y = e^{2x} \{(c_1 + c_2 x) \cos x + (c_3 + c_4 x) \sin x\}$$

$$(b) y = e^x \{(c_1 + c_2 x) \cos 2x + (c_3 + c_4 x) \sin 2x\}$$

$$(c) y = (c_1 e^x + c_2 e^{2x}) \cos x + (c_3 e^x + c_4 e^{2x}) \sin x$$

$$(d) y = e^x \{4 \cos x + c_2 \cos 2x + c_3 \sin x + c_4 \sin 2x\}$$

[Ans. b] (04 marks)

(b) Solve:

$$\frac{d^3 y}{dx^3} - y = (e^x + 1)^2 \quad [\text{VTU, July 2007}] \text{ (04 marks)}$$

**Solution.** Refer Unit V.

(c) Solve :

$$\frac{d^2 y}{dx^2} - 4 \frac{dy}{dx} + 4y = 3x^2 e^{2x} \sin 2x \quad [\text{VTU, July 2007}] \text{ (06 marks)}$$

**Solution.** Refer Unit V.

(d) Solve by the method of undetermined coefficients

$$y'' - 3y' + 2y = x^2 + e^x \quad [\text{VTU, Jan. 2008}] \text{ (06 marks)}$$

**Solution.** Refer Unit V.

6. (a) (i) The general solution of  $(x^2 D^2 - xD) y = 0$  is

$$\begin{array}{ll} (a) y = c_1 + c_2 e^x & (b) y = c_1 + c_2 x^2 \\ (c) y = c_1 + c_2 x^2 & (d) y = c_1 x + c_2 x^2 \end{array} \quad [\text{Ans. c}]$$

(ii) For the variation of parameters the value of  $W$  is

$$\begin{array}{ll} (a) y_1 y_2' - y_2 y_1' & (b) y_2 y_2' - y_1 y_2' \\ (c) y_2 y_1' - y_2 y_2' & (d) y_2 y_1' - y_2 y_1 \end{array} \quad [\text{Ans. a}]$$

(iii) The DE in which the conditions are specified at a single value of the independent variable say  $x = x_0$  is called

$$\begin{array}{ll} (a) \text{ Initial value problem} & (b) \text{ Boundary value problem} \\ (c) \text{ Final value} & (d) \text{ Both (a) and (b)} \end{array} \quad [\text{Ans. a}]$$

(iv) The DE in which the conditions are specified for a given set of  $n$  values of the independent variable is called a

$$\begin{array}{ll} (a) \text{ Initial value problem} & (b) \text{ Boundary value problem} \\ (c) \text{ Final value} & (d) \text{ Both (a) and (b)} \end{array} \quad [\text{Ans. b}] \text{ (04 marks)}$$

(b) Solve by the method of variation parameters  $y'' + y = \tan x$ .

[VTU, Jan. 2008] (04 marks)

**Solution.** Refer Unit VI.

(c) Solve:

$$x^2 \frac{d^2 y}{dx^2} + x \frac{dy}{dx} + 2y = x \cos (\log x). \quad [\text{VTU, July 2008}] \text{ (06 marks)}$$

**Solution.** Refer Unit VI.

(d) Solve:

$$\frac{d^2 y}{dx^2} + 4 \frac{dy}{dx} + 3y = e^{-x} \text{ subject to the conditions } y(0) = y'(0).$$

[VTU, Jan. 2008] (06 marks)

**Solution.** Refer Unit VI.

7. (a) (i) The Laplace transform of  $\sin^2 3t$  is:

$$(a) \frac{3}{s^2 + 36}$$

$$(b) \frac{6}{s(s^2 + 36)}$$

$$(c) \frac{18}{s(s^2 + 36)}$$

$$(d) \frac{18}{s^2 + 36}$$

[Ans. c]

(ii)  $L [e^{-3t} \cos 3t]$  is:

$$(a) \frac{s-3}{s^2 - 6s - 18}$$

$$(b) \frac{s+3}{s^2 + 6s + 18}$$

$$(c) \frac{s+3}{s^2 + 6s + 18}$$

$$(d) \frac{s-3}{s^2 + 6s - 18}$$

[Ans. b]

(iii)  $L [(t^2 + 1) u (t - 1)]$

$$(a) 2e^{-s} \frac{(1+x+s^2)}{s^3}$$

$$(b) e^{-s} \frac{(1+s+s^2)}{s^3}$$

$$(c) 2e^s \frac{(1+s+s^2)}{s^3}$$

(d) None of these

[Ans. a]

(iv) The Laplace transform of a function  $f (t)$  exists of

(a) It is uniformly continuous

(b) It is piecewise continuous

(c) It is uniformly continuous and of exponential order

(d) It is piecewise continuous of exponential order

[Ans. d] (04 marks)

(b) Prove that

$$\int_0^{\infty} e^{-3t} t \sin t dt = \frac{3}{50}.$$

[VTU, Jan. 2006] (04 marks)

**Solution.** Refer Unit VII.

(c) A periodic function  $f (t)$  of period  $2a$  is defined by

$$f (t) = \begin{cases} a & \text{for } 0 \leq t < a \\ -a & \text{for } a \leq t \leq 2a \end{cases}$$

$$\text{show that } L \{f (t)\} = \frac{a}{s} \tan b \left( \frac{as}{2} \right).$$

[VTU, July 2008] (06 marks)

**Solution.** Refer Unit VII.

(d) Express  $f (t)$  in terms of the Heavisides unit step function and find its Laplace transforms

$$f (t) = \begin{cases} t^2, & 0 < t < 2 \\ 4t, & 2 < t < 4 \\ 8, & t > 4 \end{cases}$$

[VTU, Jan. 2006] (06 marks)

**Solution.** Refer Unit VII.

8. (a) (i)  $L^{-1} \left[ \frac{1}{s^2 + 3^2} \right]$  is:

(a)  $\frac{1}{3} \sin 3t$

(b)  $\sin h 3t$

(c)  $\frac{1}{3} \sin h 3t$

(d)  $\frac{1}{3} \cos 3t$

[Ans. a]

(ii)  $L^{-1} \left[ \frac{1}{s^{n+1}} \right]$  is:

(a)  $\frac{t^n}{\Gamma(n)}$

(b)  $\frac{t^{n-1}}{\Gamma(n)}$

(c)  $\frac{t^{n+1}}{\Gamma(n+1)}$

(d)  $\frac{t^{n-1}}{\Gamma(n-1)}$

[Ans. b]

(iii) Laplace transform of  $f''(t)$  is

(a)  $s^2 L\{f(t)\} - s f(0) - f'(0)$

(b)  $s^2 L\{f(t)\} - f'(0)$

(c)  $s^2 L\{f(t)\} + s f(0) + f(0)$

(d) None of these

[Ans. a]

(iv) For  $L^{-1} \left[ \frac{1}{s^n} \right]$  is:

(a)  $n > -1$

(b)  $n \geq -1$

(c)  $n = 1, 2, \dots$

(d)  $n < 1$

[Ans. c] (04 marks)

(b) Find the inverse Laplace transform of  $\frac{2s-1}{s^2-5s+6}$ . [VTU, Jan. 2006] (04 marks)

**Solution.** Refer Unit VIII.

(c) By employing convolution theorem; evaluate

$$L^{-1} \left[ \frac{s^2}{(s^2 + a^2)(s^2 + b^2)} \right].$$

[VTU, Jan. 2008] (06 marks)

**Solution.** Refer Unit VIII.

(d) Solve using Laplace transforms

$$\frac{d^2 y}{dt^2} - 3 \frac{dy}{dt} + 2y = 4e^{2t}$$

given that  $y(0) = -3$  and  $y'(0) = 5$ .

[VTU, July 2008] (06 marks)

**Solution.** Refer Unit VIII.

□□□