



RADIANT
HEATING SYSTEMS

**THREE-WAY
MIXING VALVE**

INSTALLATION GUIDE



Three-way Mixing Valve Installation Guide

Table of Contents

- Introduction 1**
- Piping Requirements 1**
- Application 2**
- Installation 3**
- Actuator Installation and Removal 4**
- Powering the Control 5**
 - Intermittent Operation
 - Continuous Operation
- Sensor Wiring 6**
 - Outdoor Sensor
 - General Tips for System Supply and Boiler Return Sensors
 - System Supply Sensor
 - Boiler Return Sensor
- Sequence of Operation 8**
 - Power Up and Heat Request
 - Reset Ratio
 - Maximum/Minimum System Supply Temperature
 - Minimum Boiler Return Temperature
 - Warm Weather Shut Down (WWSD)
 - Outdoor Reset
 - Reset Ratio Configuration
 - Reset Ratio Formula
- Troubleshooting 11**
- Setting Adjustments 12**
 - Sensor Testing
- Product Specifications 13**
- Materials of Construction 14**
 - Dimensions and Weights

**Three-way Mixing
Valve Installation Guide**
Published by Uponor North America
5925 148th Street West
Apple Valley, MN 55124 USA
Phone: 800.321.4739
Fax: 952.891.2008
www.uponorpro.com

© 2014 Uponor North America
All Rights Reserved.
First Edition October 2013
Printed in the United States of America

Introduction

The Uponor Three-way Mixing Valve (A3040075, A3040100) is a microprocessor-controlled valve designed to regulate the supply water temperature to a radiant heating system by modulating the position of the valve. Mixed supply setpoint can be configured to reset from the outdoor air temperature. An optional boiler sensor can be used to provide boiler protection in non-condensing boiler applications.

Note: Do not use the Three-way Mixing Valve for potable-water tempering or in any application where scalding can occur as a result of exposure to the tempered water.

Piping Requirements

Refer to the following piping requirements for installing an Uponor Three-way Mixing Valve.

1. Use primary/secondary piping to hydraulically isolate the boiler loop from the injection or system loop. There can be no more than 4 pipe diameters between the tees in the boiler loop (see **Note 1** in **Figure 1**).
2. There must be at least 6 pipe diameters of straight pipe on either side of the tees (see **Note 2** in **Figure 1**) to prevent the momentum of water in the boiler loop from pushing flow through the injection loop.
3. Ensure a minimum of 1 ft. drop on the return pipe of the injection loop to create a thermal trap and prevent unwanted heat transfer (see **Note 3** in **Figure 1**).

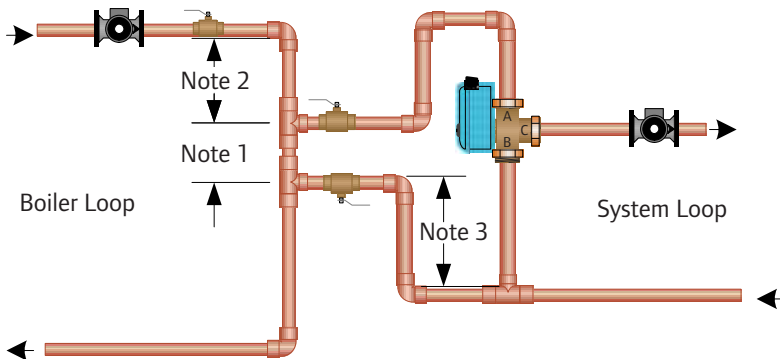

Figure 1: Three-way Mixing Valve Piping Requirements

Application

The Uponor Three-way Mixing Valve can be used to mix the hot boiler water temperature with the cooler return water temperature from the system loop. The position of the valve is modulated to inject different rates of hot water into the cool system return water. This allows the heating system to receive virtually any water temperature. Because most cast-iron boilers cannot operate at low temperatures, the Uponor Three-way Mixing Valve can be modulated back in order to prevent the boiler from operating at cold temperatures (provided a boiler return sensor is installed in the system).

Flow GPM	Cv = 4.5	
	PSI	Ft. Head
½	0.01	0.03
1	0.05	0.11
2	0.20	0.46
4	0.79	1.82
6	1.78	4.10
8	3.16	7.29
10	4.94	11.39
12	7.11	16.41

Table 1: Pressure Drop Chart

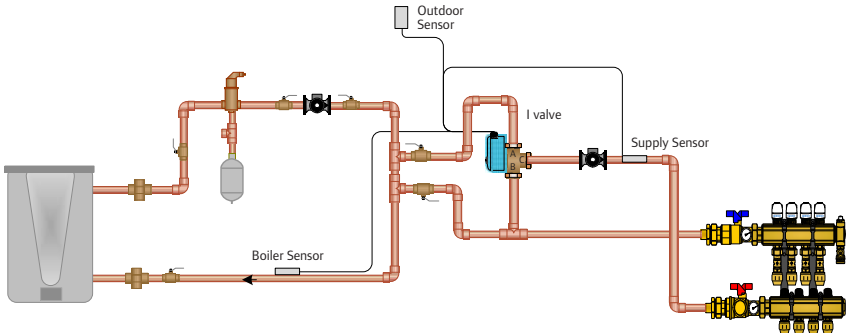

Figure 2: Three-way Mixing Valve Typical Piping Diagram

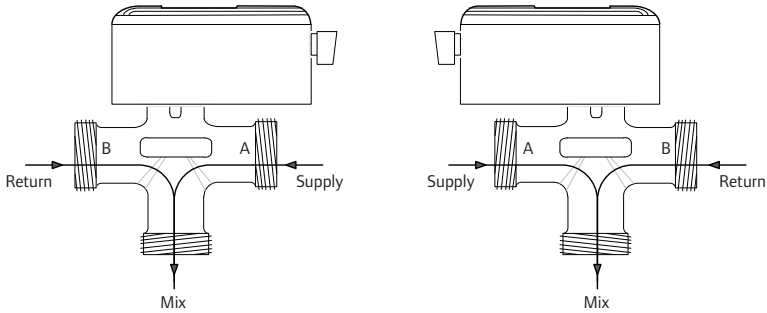

Figure 3: Three-way Mixing Valve Installations

Installation

Refer to the following installation instructions to properly install the Uponor Three-way Mixing Valve.

1. The valve body can install in any position and orientation. Install the power connections over the supply port to ensure proper flow direction (see **Figure 3**).
2. Before installing the valve body, refer to **Figure 4** and the Dimensions section on **page 14** for clearances.
3. Before attaching the actuator, it is acceptable to submerge the valve body in water to test for leaks.

Important! Remove the valve gaskets and the actuator from the valve body before soldering. Ensure the ball valve is in the full open position before soldering. (Note that the valve is shipped in the full closed position.)

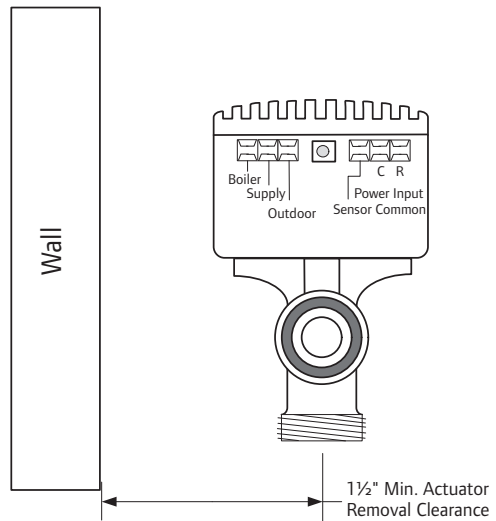

Figure 4: Acceptable Clearance from a Wall

Actuator Installation and Removal

1. The actuator can attach to the valve body in either direction with the power connections over the supply port to ensure proper flow direction.
 2. To remove the actuator prior to soldering, rotate it counterclockwise approximately 30 degrees and lift upward approximately $\frac{3}{4}$ " (see **Figure 5**).
 3. To reassemble the actuator to valve body, position the actuator so the D-shaped valve stem aligns properly with the D-shaped actuator drive cavity.
- Note:** The D-shaped stem design allows for correct insertion every time.
4. Next, slide the valve stem into the actuator cavity and rotate it until the actuator slips over the valve's locking posts.
 5. Once the actuator is flush with valve body, turn the actuator clockwise and lock it into position.

Step 1

Rotate actuator head counter clockwise 30 degrees.

Step 2

Lift actuator from valve $\frac{3}{4}$ " to remove.

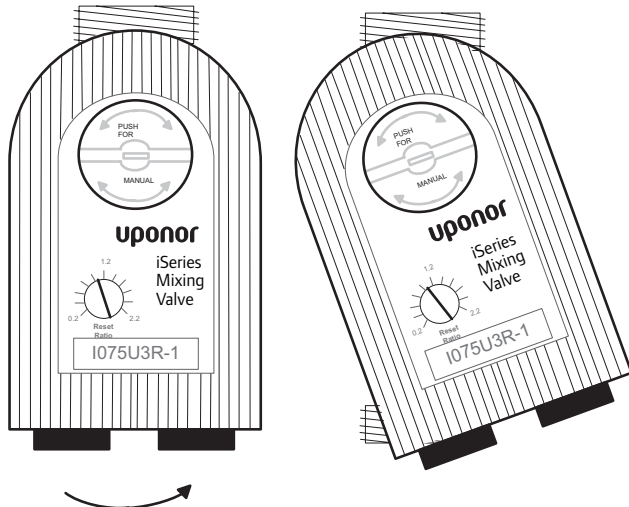

Figure 5: Actuator Removal

Powering the Control

All terminals on the Uponor Three-way Mixing Valve are removable. To prevent damage to the electronics, disconnect all plugs before applying power and check voltages and sensors. After testing the circuits, plug in the terminals.

Warning: Make all wiring connections in accordance with applicable electrical codes.

Caution: To prevent electrical shock, disconnect electric power to the system at the main fuse or circuit breaker box until installation is complete. When installing a service switch, more than one disconnect switch may be required to de-energize this device for servicing.

Intermittent Operation

1. Connect the two wires on the end switch of the Uponor Zone Control Module (ZCM) to the R and W terminals on the Uponor Pump Relay.
2. Connect the R terminal on the Three-way Mixing Valve to the W terminal on the pump relay.
3. Connect the C terminal on the Three-way Mixing Valve to the C terminal on the pump relay.

Continuous Operation

For continuous operation, wire the transformer directly to the R and C terminals on the Three-way Mixing Valve.

Important! Ensure no power is present during this process.

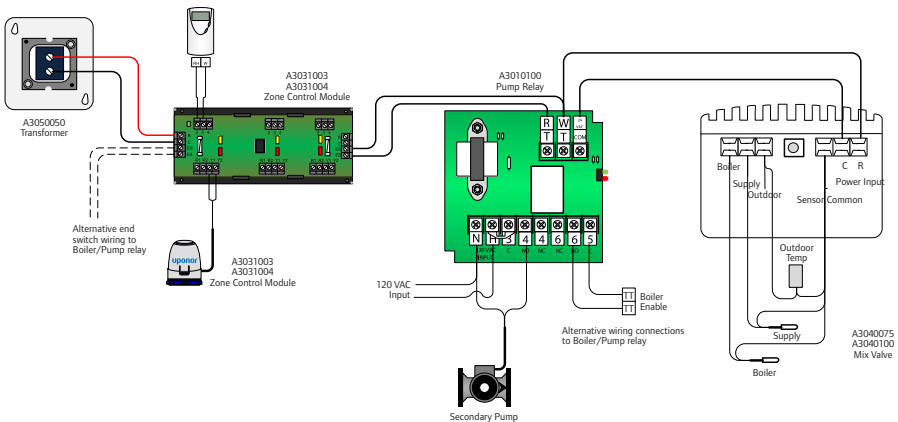

Figure 6: Three-way Mixing Valve Typical Wiring Diagram

Sensor Wiring

Do not apply power to the sensor terminals as this will damage the Three-way Mixing Valve. The wiring terminals for the sensors may be removed for ease of installation.

Outdoor Sensor

1. Remove the screw and pull the front cover off the sensor enclosure.
2. The outdoor sensor can mount either directly onto a wall or in a 2" x 4" electrical box.
3. When mounting the sensor to a wall, ensure the wiring enters through the back or bottom of the enclosure. Do not mount the sensor with the conduit knockout facing upwards as rain could enter the enclosure and damage the sensor.
4. Mount the sensor on a wall which best represents the heat load on the building (e.g., a northern wall for most buildings and a southern-facing wall for buildings with large, south-facing glass areas).
5. Do not expose the sensor to heat sources such as ventilation or window openings.
6. Install the sensor at an elevation above the ground that will prevent tampering.
7. Connect 18 AWG or similar wire from the outdoor sensor directly into the SENSOR COMMON and OUTDOOR terminals on the Three-way Mixing Valve.
8. Replace the front cover of the sensor enclosure.

the building (e.g., a northern wall for most buildings and a southern-facing wall for buildings with large, south-facing glass areas).

Note: To prevent heat transmission through the wall from affecting the sensor reading, it may be necessary to install an insulating barrier behind the enclosure.

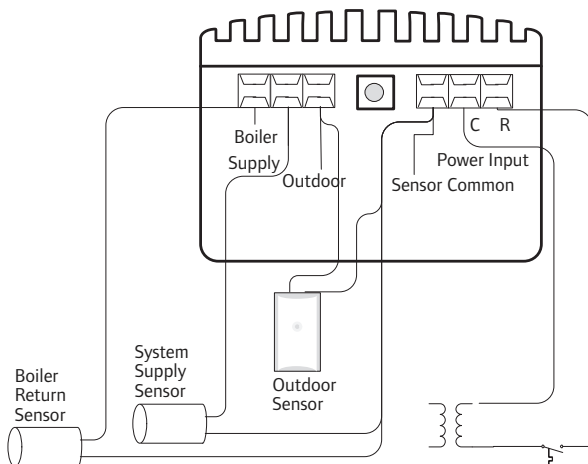

Figure 7: Control Wiring Diagram

General Tips for System Supply and Boiler Return Sensors

- Strap the sensors directly to the pipe using a cable tie.
- Place insulation around the sensor to reduce the effect of air currents on the sensor measurement.
- Place the sensors downstream from a pump or after an elbow or similar fitting.

Note: This is especially important if the system is using large-diameter pipes because the thermal stratification within the pipe can result in erroneous sensor readings. Proper sensor location requires that the fluid is thoroughly mixed within the pipe before it reaches the sensor.

- If the System Supply Sensor is measuring duct temperature, mount the sensor in such a manner so it measures the average duct outlet temperature.

System Supply Sensor

Wire the system supply sensor by connecting the two wires from the supply sensor directly into the SENSOR COMMON and SUPPLY terminals on the Three-way Mixing Valve.

Boiler Return Sensor

Wire the boiler return sensor by connecting the two wires from the boiler return sensor directly into the SENSOR COMMON and BOILER terminals on the Three-way Mixing Valve.

Sequence of Operation

Power Up and Heat Request

Upon power up, the LED turns green and the control starts operation. For intermittent operation, power to the Three-way Mixing Valve can be switched through an end switch (e.g., Uponor ZCM) or a thermostat. For continuous operation, power can be connected directly to the Three-way Mixing Valve.

Reset Ratio

Once the Three-way Mixing Valve is powered up, it provides outdoor reset at the supply sensor location. The Three-way Mixing Valve targets a supply temperature based on the outdoor temperature measured and the Reset Ratio dial setting. The Reset Ratio is set using the formula on **page 10**.

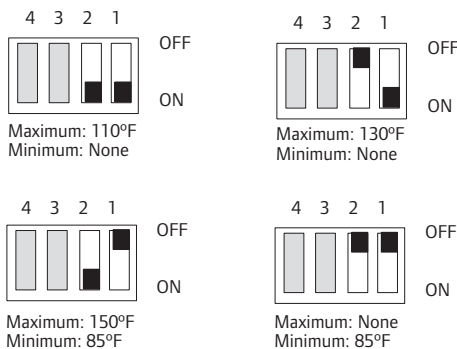

Figure 8: DIP Switches 1 and 2

Maximum/Minimum System Supply Temperature (DIP Switches 1 and 2)

The Three-way Mixing Valve can be configured to set a maximum supply water target temperature to help protect system components, such as floor coverings, by preventing excessive water temperatures.

Select the maximum target temperature using DIP Switches 1 and 2. When selecting a maximum supply target temperature of 150°F (66°C) or “NONE”, the Three-way Mixing Valve also enables a minimum supply target temperature of 85°F (29°C). This function is typically used in staple-up radiant floor heating applications to ensure enough heat delivery during mild outdoor temperatures.

If the actual supply water temperature approaches the maximum or minimum system supply, the Three-way Mixing Valve modulates the valve down and the green LED flashes rapidly (reduced output).

Note: If selecting “NONE” for minimum system supply temperature, the setpoint system supply temperature will equal the Warm Weather Shut Down (WWSD) of 70°F (21.1°C).

Minimum Boiler Return Temperature (DIP Switch 3)

The boiler protection function prevents low temperatures back to the boiler (provided a boiler sensor is installed).

The Three-way Mixing Valve monitors the boiler return temperature and modulates the valve down when the return temperature is near the minimum setting selected via DIP Switch 3.

When DIP Switch 3 is in the on position, the minimum temperature is set to 120°F (49°C). When the switch is turned off, the minimum temperature is 135°F (57°C).

When using low-temperature boilers, such as condensing or electric, it is possible to disable the boiler minimum temperature by powering up the control without a boiler return sensor. When the Three-way Mixing Valve is being modulated towards the closed position to protect the boiler, the green LED flashes rapidly (reduced output).

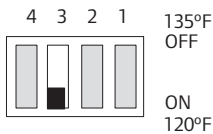

Figure 9: DIP Switch 3

Warm Weather Shut Down (WWSD) (DIP Switch 4)

Warm Weather Shut Down (WWSD) function closes the Three-way Mixing Valve when the outdoor temperature is warmer than 70°F (21°C). WWSD is enabled by turning DIP Switch 4 to the on position. The green LED slowly flashes to signal the WWSD status.

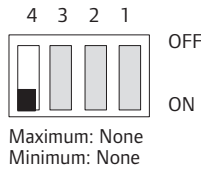

Figure 10: DIP Switch 4

Note: If outdoor air temperature sensor fails or is not installed, the Three-way Mixing Valve will use 32°F (0°C) as the outdoor reference. The LED light will flash 3 times, pause, flash 3 times, pause, etc. See **Table 2 on page 11** for LED indicator information.

Outdoor Reset

To properly control a hot-water heating system, the heat supplied to the building must equal the heat lost by the building.

- The heat supplied to the building is directly proportional to the temperature of the water and the surface area of the

heating element. The higher the temperature of the water flowing through the heating terminal, the higher the heat output.

- The heat lost from a building is dependent on the outdoor temperature. As the outdoor temperature drops, the building heat loss increases.

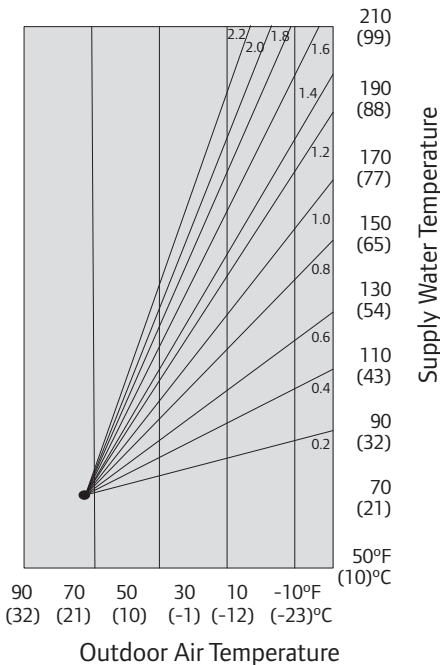

These two facts lead to the concept of outdoor reset which increases the supply water temperature as the outdoor temperature drops. Using this approach, the heat lost from the building is matched by the heat provided by the terminal units, therefore providing more comfort and energy savings.

Reset Ratio Configuration

The Reset Ratio sets the relationship between outdoor temperature and supply water temperature. It determines the amount the supply water temperature is raised for every 1 degree outdoor temperature drop. For example, if a Reset Ratio of 1.2 is selected, the supply water temperature increases 1.2 degrees for every 1 degree of outdoor temperature drop.

Figure 11: Reset Ratio Chart

Reset Ratio Formula

$$\frac{\text{Design Supply Temp.} - \text{WWSD (70°F/21.1°C)}}{\text{WWSD (70°F/21.1°C)} - \text{Design Outdoor Temp.}} = \text{Reset Ratio}$$

Example

Design Supply Temp. = 110°F/43.3°C

WWSD = 70°F/21.1°C (fixed value)

Design Outdoor Temp. = 8°F/-13.3°C

$$\frac{110 - 70}{70 - 8} = 0.6$$

Troubleshooting

As in any troubleshooting procedure, it is important to isolate a problem as much as possible before proceeding. When the control flashes an error message, identify the fault and

follow standard testing procedures to confirm the problem. If you suspect a wiring fault, return to the wiring section in this installation guide and carefully check all external wiring and wiring connections.

LED	Status	Description
Green	Solid	Power is on.
Green	Slow Flash	Warm Weather Shut Down is enabled.
Green	Fast Flash	Reduced Output (Boiler protection is activated.)
Red	Intermittent Single Flash (Flash, Pause, Flash, Pause, etc.)	System Supply Sensor Fault If either of the system supply temperature maximum DIP switches (1 and/or 2) is on, the actuator closes. However, if the switches are off, the valve output will open to 10%.
Red	Intermittent Double Flash (Flash, Flash, Pause, Flash, Flash, Pause, etc.)	Boiler Sensor Fault Boiler protection will be ignored.
Red	Intermittent Triple Flash (Flash, Flash, Flash, Pause, Flash, Flash, Flash, Pause, etc.)	Outdoor Sensor Fault Supply setpoint will be calculated using 32°F (0°C) outdoor air.

Table 2: LED Indicators

Setting Adjustments

If the outdoor temperature is cold and the building is cold, increase the Reset Ratio setting by one notch per day.

Sensor Testing

Refer to the steps below to properly test the sensors. Be sure to use a good-quality test meter capable of measuring up to 5,000 k Ω (1 k Ω = 1000 Ω) to measure the sensor resistance, and measure the actual temperature with a good-quality digital thermometer.

1. Measure the temperature using the thermometer.
2. Measure the resistance of the sensor at the Three-way Mixing Valve.

Important! Ensure the wires from the sensor are not connected to the Three-way Mixing Valve while performing this test. Remove the wiring terminals by gently pulling them from the Three-way Mixing Valve.

3. Using the data in **Table 2**, estimate the temperature measured by the sensor. The sensor and thermometer readings should be close. If the test meter reads a very high resistance, there may be a broken wire, a poor wiring connection or a defective sensor. If the resistance is very low, there may be a short in the wiring, moisture in the sensor or the sensor may be defective. To test for a defective sensor, measure the resistance directly at the sensor location.

Temperature		Resistance	Temperature		Resistance	Temperature		Resistance	Temperature		Resistance
°F	°C	Ohms	°F	°C	Ohms	°F	°C	Ohms	°F	°C	Ohms
-30	-34	234196	30	-1	34558	90	32	7334	150	66	2045
-20	-29	165180	40	4	26099	100	38	5828	160	71	1689
-10	-23	118018	50	10	19900	110	43	4665	170	77	1403
0	-18	85362	60	16	15311	120	49	3760	180	82	1172
10	-12	62465	70	21	11883	130	54	3050	190	88	983
20	-7	46218	80	27	9299	140	60	2490	200	93	829

Table 3: Temperature and Resistance

Product Specifications

Maximum Operating Pressure: 300 psi (2,100 kPa)

Maximum Shutoff Pressure: 125 psi (875 kPa)

Fluid Temperature Range: 20° to 240°F, (-7° to 115°C)
at 135°F (57°C) ambient

Service: Closed-system hot and chilled water, up to 50% glycol

Seat Leakage: Drop-tight close-off

Electrical Rating: 24 VAC ±10%, 60 Hz

Important! Do not exceed number of valves per transformer rating. For example, do not use more than five (5) Three-way Mixing Valves per 40VA transformer.

Power Consumption: 7.2 Watts, 0.3 Amps

Part No.	Valve Size	Cv (Kv) Ft. of Pipe Equivalent
A3040075	¾"	4.5 (3.9)/44.2
A3040100	1"	4.5 (3.9)/44.2

Table 4: Three-way Mixing Valves

Materials of Construction

Actuator

Body: High-performance Engineered Polymer

Gears: High-performance Internally Lubricated Engineered Polymer

Valve

Body: Forged Brass

Stem: Brass

Press Ring: Brass

Ball: Brass (Chrome Plated)

Seat: Modified Teflon®

O-rings: EPDM

Valve Size	A	B	C	D	E	Weight
¾"	3"	2⅜"	5⅞"	2⅞"	4¾"	1.5 lbs.
1"	3"	2⅜"	6⅞"	2⅞"	7¼"	1.5 lbs.

Table 5: Dimensions and Weights

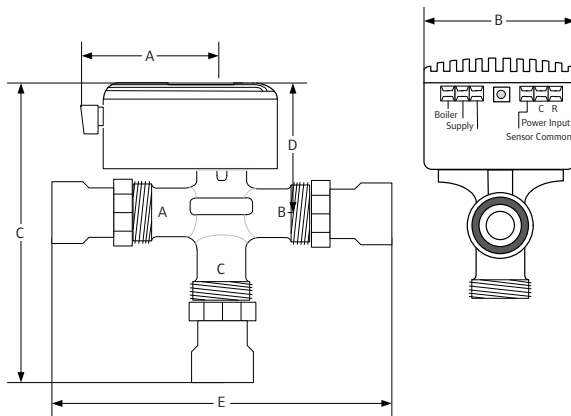

Figure 12: Three-way Mixing Valve Dimensions

Uponor, Inc.
5925 148th Street West
Apple Valley, MN 55124 USA
Tel: 800.321.4739
Fax: 952.891.2008

Uponor Ltd.
2000 Argentia Rd., Plaza 1, Ste. 200
Mississauga, ON L5N 1W1 CANADA
Tel: 888.994.7726
Fax: 800.638.9517



www.uponorpro.com