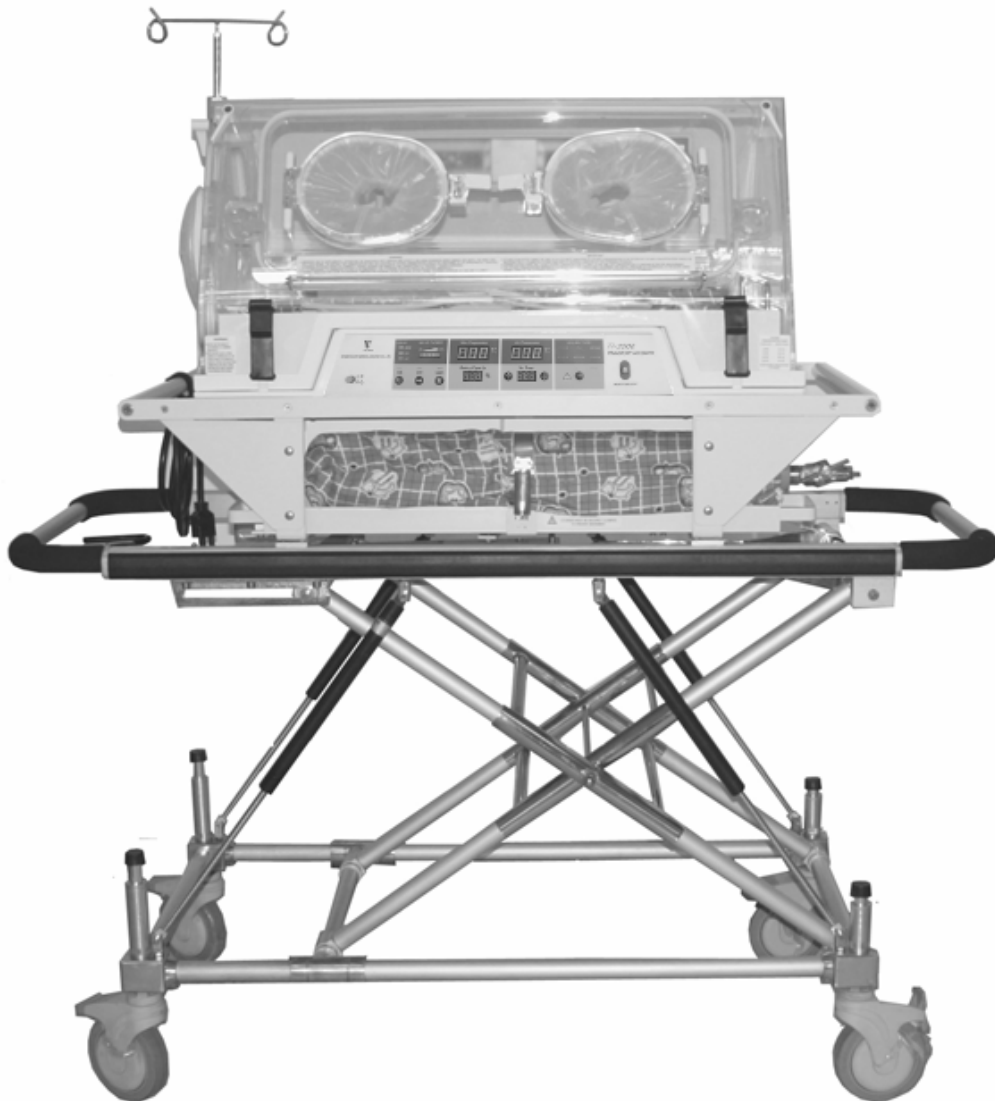




DAVID® NINGBO DAVID

EDITION/REVISION A/0

# SERVICE MANUAL



**TI-2000**  
**TRANSPORT INCUBATOR**

## NINGBO DAVID MEDICAL DEVICE CO., LTD.

ADD: NO.158 DAQING ROAD SHIPU TOWN XIANGSHAN COUNTY ZHEJIANG PROVINCE P.R.CHINA

POST CODE: 315731

FAX: 0086-574-65962111

MARKETING CENTER: NO. 100, JINGHUA ROAD, HI-TECH INDUSTRIAL DEVELOPMENT ZONE,  
NINGBO, CHINA

POST CODE: 315000

TEL: 0086-574-87800008, 87800009

FAX: 0086-574-87801111

E-MAIL: sales@chinadavid.cn      david@mail.nbptt.zj.cn

WEBSITE: <http://www.nbdavid.com>

EUROPEAN REPRESENTATIVE: SHANGHAI INTERNATIONAL HOLDING CORP. GMBH (EUROPE)

ADD: EIFFESTRASSE 80, 20537 HAMBURG, GERMANY

TEL: 0049-40-2513175

FAX: 0049-40-255726

EDITION/REVISION A/O

## WARRANTY

The product described in this manual is warranted against defects in materials or workmanship for one year from the dates of shipment except the following items:

1. All consumable and disposable products are guaranteed to be free for repairing because of defects upon shipment only.
2. Normal drop-in services are not included in the 1-year warranty.
3. Damage caused by improper carrying; for example, drop the device on the ground during transporting or moving.
4. Damage caused by fire, earthquake, flood and other natural calamity.

During the warranty period any defective parts other than those listed above will be replaced at no charge to the customer. This warranty is rendered void and our company cannot be held liable for conditions resultant there from if:

1. Damage to the unit is incurred as a result of mishandling.
2. The customer fails to maintain the unit in a proper manner.
3. The customer uses any spare parts, accessories, or fittings not specified or sold by our company when this product is changed, maintained or repaired.
4. Damage caused by ignoring the attention or instruction of the manual.
5. Damage caused by ignorance of the instructions in this manual.
6. Damage caused by the environment of operation, including the electric condition or installation conditions, which do not accord with the instruction of the manual.
7. Damage caused by unauthorized dealer.
8. Damage caused by reducing the system safety due to stalling the accessories, which do not accord with the safety requirements of this product.
9. Enlarge the application scope of this product at will.

The company is not responsible for the invalid warranty caused by the damages accidentally including the wastage, the belongings damages or individual injury.

Prior to initial use, the capability and mechanized integrity of the product should be tested, afterward, at least once every one year; at the same time, a record is a must. To comply with this standard, we recommend that you participate in our preventive maintenance program during the warranty period. This service can be performed by certified technicians and authorized dealers that have passed through our product service department.

## SERVICE COMMITMENT

For optimal performance, product service should be performed only by qualified service personnel. Technical Services representatives can be reached for fixations and are dispatched for required maintenance by calling 0086-574-87800002, 87801003. Customers outside China should contact their local factory-authorized distributor for service.

The device, accessories and the packaging have to be disposed of waste correctly at the end of the usage. Please follow Local Ordinances or Regulations for disposal.

## COMPLEMENTARY NOTICE

Since our factory, conducts a continuous product improvement program, circuit and component improvements are sometimes incorporated into equipment before they can be incorporated into the printed manuals. Therefore, some parts used in your equipment may be different than those which appear in the parts list of this manual. This sometimes occurs due to difficulty in parts procurement, but does not alter the function of the equipment. When this occurs, changed material is provided on separate sheets of the manual. If it brings about trouble in reading this manual, we beg your pardon.

This manual contains all of the repairs information. Repairs and authorized modifications should be performed only by qualified service personnel to maintain your warranty and to avoid creating safety hazards. We cannot assume responsibility for any conditions affecting the proper operation of this equipment which may result from unauthorized repair or modification.

## TABLE OF DEFINITIONS AND SYMBOLS

### TECHNICAL DEFINITIONS

**INCUBATOR TEMPERATURE.** Air temperature at a point 10cm above and centered over the mattress surface.

**INCUBATOR TEMPERATURE.** Air temperature at a point 10cm above and centered over the mattress surface.

**INCUBATOR TEMPERATURE EQUILIBRIUM.** The condition reached when the average incubator temperature does not vary more than 1.0°C over a period of one hour.

**TEMPERATURE UNIFORMITY.** The amount by which the average temperature at each of four points 10cm above the mattress surface differs from the average incubator temperature at temperature equilibrium.

**TEMPERATURE VARIABILITY.** The variability of the incubator temperature that will be observed over a one-hour period after incubator temperature equilibrium has been reached.

**TEMPERATURE RISING TIME.** The time required for the incubator temperature to rise 11°C, when the air control temperature is at least 12°C above ambient.

**TEMPERATURE ALARM CHECKOUT STATE.** The difference point between the real temperature and control temperature is within  $\pm 0.2^{\circ}\text{C}$  and such status lasts for over 3 minute.(When check out the temperature alarm function, operation should be enter this state.)

**NOTE, IMPORTANT, CAUTION AND WARNING**


**NOTE:** A note is inserted in text to point out procedures or conditions that may otherwise be misinterpreted or overlooked. A note may also be used to clarify apparently contradictory or confusing situations.

**IMPORTANT:** Similar to a **Note** but used where greater emphasis is required.

**CAUTION:** A Caution is insert in a text to call attention to a procedure that if not followed exactly, can lead to damage or destruction of the equipment or improper operation.









**WARNING:** A Warning is insert in a text to call attention to dangerous or hazardous conditions inherent to the operation, cleaning, and maintenance of the equipment that may result in personal injury or death of the operator or patient.

**SYMBOLS**

	Attention! Consult Accompanying Documents.		Skin Mode Key
	Class I Equipment		Air Mode Key
	Type BF Applied Part		Temperature Set Point Up Key
	Caution: Electric Shock Hazard		Temperature Set Point Down Key
	Protective Earth (Ground)		Set Key
	Earth (Ground)		Silence/Reset Key
	Caution, Hot Surface		Battery Active Indicator
	Controller Switch On		Controller Switch Off
	Power Switch On		Power Switch Off

**EXTERNAL DC: DC12V 10A/DC24V 6A** DC12V 10A/24V 6A Power Supply

**INPUT: 220-230 ~ 50Hz** AC 220-230V ,50Hz Power Supply

	Lighting Switch On		Lighting Switch Off
	>37°C function key		>37°C indicator
	3.15AL/250V F Type Fuse		0123 CE MARKING
	Date Of Manufacture		Serial Number

## SEASONAL SAFETY CHECK

1. Please clean the plug of power cord at least once a year. Too much dust on plug may cause the fire.
2. The following safety checks should be performed at least every 12 months by a qualified person who has adequate training, knowledge, and practical experience to perform these tests. The data should be recorded in an equipment log. If the device is not functioning properly or fails any of the above tests, the device has to be repaired.
  - ①. Inspect the equipment and accessories for mechanical and functional damage.
  - ②. Inspect the safety relevant labels for legibility.
  - ③. Inspect the fuse to verify compliance with rated current and breaking characteristics.
  - ④. Verify that the device functions properly as described in the instructions for use.
  - ⑤. Test the protection earth resistance according IEC 60601-1:1988 + A1:1991 + A2:1995: Limit 0.1Ω.
  - ⑥. Test the earth leakage current according IEC 60601-1:1988 + A1:1991 + A2:1995: Limit: NC 500μA, SFC: 1000μA.
  - ⑦. Test the enclosure leakage current according to IEC 60601-1:1988 + A1:1991 + A2:1995: Limit: NC 100μA, SFC: 500μA.
  - ⑧. Test the patient leakage current according IEC 60601-1:1988 + A1:1991 + A2:1995: Limit: for a.c.: 100μA (BF), for d.c.: 10μA (BF).
  - ⑨. Test the patient leakage current under single fault condition with mains voltage on the applied part according IEC 60601-1:1988 + A1:1991 + A2:1995: Limit: for a.c.:500μA (BF), for d.c.: 50μA (BF).
  - ⑩. According to the test methods of IEC 60601-1:1988 + A1:1991 + A2:1995, the patient leakage current (net voltage should be added on the applied part) of the testing device must less than 5000μA.
  - ⑪. Test the patient auxiliary leakage current according IEC 60601-1:1988 + A1:1991+ A2:1995: Limit: NC for a.c.: 100μA (BF), for d.c.: 10μA (BF).SFC 500μA (BF), for d.c.: 50μA (BF).

## TABLE OF CONTENTS

SECTION	PAGE
<b>1. GENERAL INFORMATION</b> .....	<b>1-1</b>
1.1 INTRODUCTION.....	1-1
1.2 ACCESSORIES.....	1-1
<b>2. INSTALLATION</b> .....	<b>2-1</b>
2.1 UNPACKING.....	2-1
2.2 ASSEMBLING THE HOOD ON THE CABINET.....	2-1
2.3 CONNECTION TO EXTERNAL POWER SOURCES.....	2-4
2.4 INSTALLATION OF OXYGEN CYLINDERS.....	2-5
2.5 CONNECTION OF REGULATOR.....	2-5
2.6 OPERATION CHECKOUT PROCEDURE.....	2-6
<b>3. TECHNICAL INFORMATION</b> .....	<b>3-1</b>
3.1 SPECIFICATION.....	3-1
3.2 WORKING PRINCIPLE .....	3-6
3.2.1 GENERAL.....	3-6
3.2.2 TEMPERATURE CONTROL.....	3-9
3.2.3 ALARMS.....	3-9
3.2.4 SILENT HAND PORTS, IRIS PORTS AND IV SOFT PORT.....	3-12
<b>4. PREVENTIVE MAINTENANCE</b> .....	<b>4-1</b>
4.1 GENERAL.....	4-1
4.2 CLEANING.....	4-1
4.2.1 DISASSEMBLY FOR CLEANING.....	4-1
4.2.2 CLEANING AFTER DISASSEMBLY.....	4-3
4.2.3 REASSEMBLY AFTER CLEANING.....	4-4
4.3 GAS STERILIZATION.....	4-6

---

<b>5. MAINTENANCE</b> .....	<b>5-1</b>
5.1 INTRODUCTION.....	5-1
5.2 REPLACEMENT OF INNER BATTERY AND FUSE.....	5-1
5.3 REPLACEMENT OUTER FUSE.....	5-2
5.4 MAINTENANCE AND REPLACEMENT AND THE STORAGE BATTERY.....	5-2
5.5 SYSTEM SET PROCEDURE.....	5-4
5.5.1 INTRODUCTION.....	5-4
5.5.2 BRIEF INTRODUCTION.....	5-4
5.5.3 PROCEDURE.....	5-5
5.6 PROCEDURE OF TROUBLE-SHOOTING.....	5-7
5.6.1 INTRODUCTION.....	5-7
5.6.2 TEST DEVICE.....	5-7
5.6.3 TEMPERATURE SIMULATION DEVICE.....	5-8
5.6.4 ALARM CODE.....	5-9
5.6.5 CHECK FLOW CHART.....	5-11
<b>6. REPLACEMENT SPARE PARTS</b> .....	<b>6-1</b>
6.1 PREFACE.....	6-1
<b>7. DIAGRAMS</b> .....	<b>7-1</b>
7.1 GENERAL.....	7-1



## SECTION 1 GENERAL INFORMATION

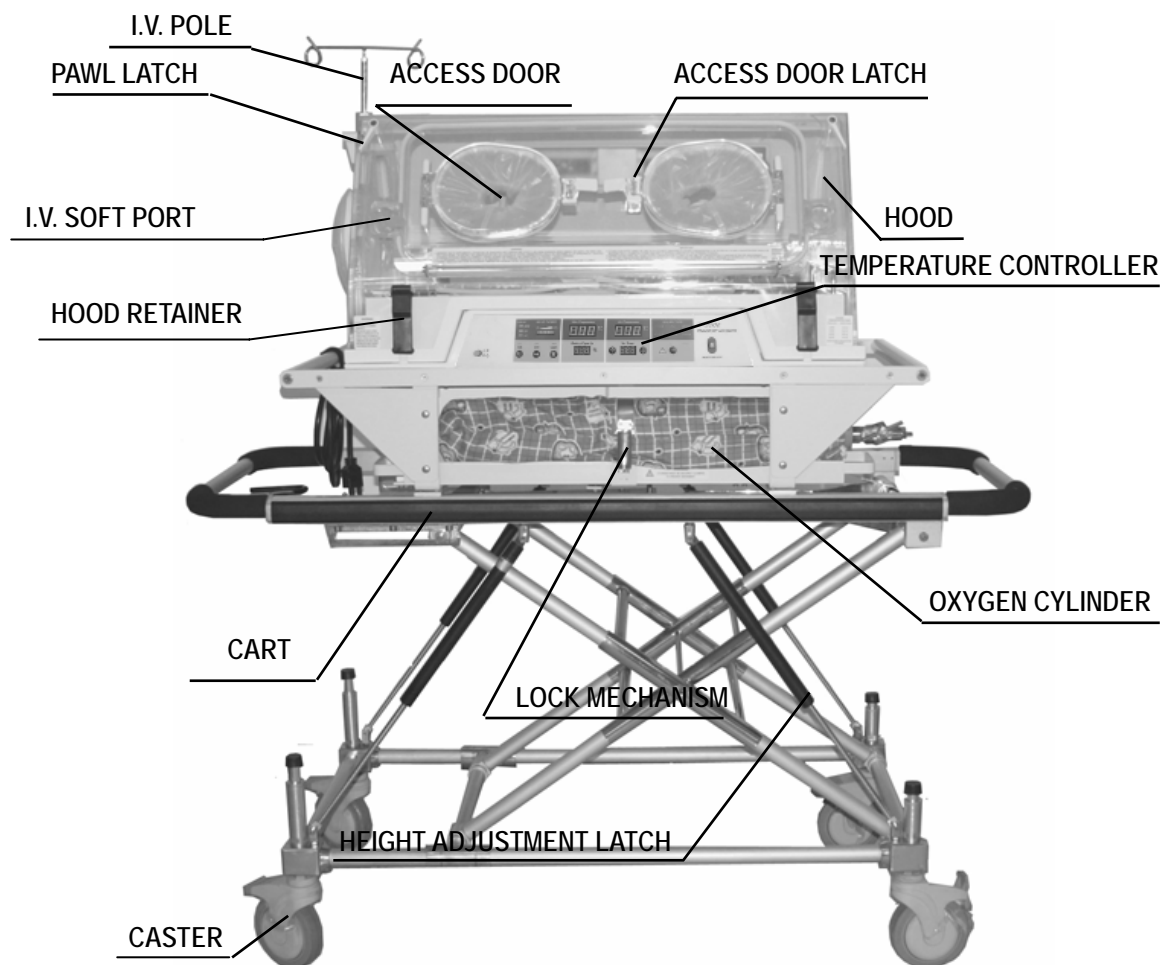
### 1.1 INTRODUCTION

This manual provides instructions for installation, maintenance and repair the David transport Incubators, Model TI-2000.

This manual is intended for use only by trained, qualified service personnel. Instructions for the operator of the equipment are provided in a separate operator's manual.

### 1.2 ACCESSORIES

Accessories available of use with the Incubators are illustrated in Figure 1.1. Refer to Section 6 of this manual for part numbers.



FIGUER 1.1 DESCRIPTION OF PARTS

## SECTION 2

### INSTALLATION

#### 2.1 UNPACKING

Typically, the stand and the hood are shipped in separate cartons. When removing the equipment from the cartons, take care not to scratch or damage unprotected surfaces. Remove all packing materials from the shell assembly and check all the spare parts according to the packing list.

#### 2.2 ASSEMBLING THE HOOD ON THE STAND

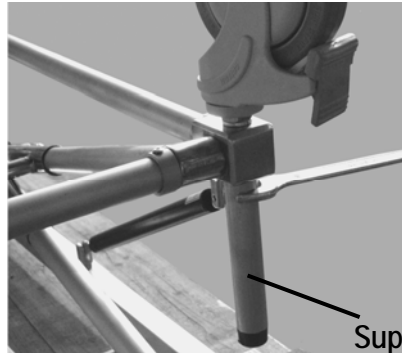
**WARNING: For safety, the Transport Incubator should always be handled by two persons.**

A. See figure 2.1, install the caster and connect the unit stand and the unit box.

1. Install the spring washer on the wheel, and then connect the stand, fasten it with spanner and from the connection of support pole and stand.



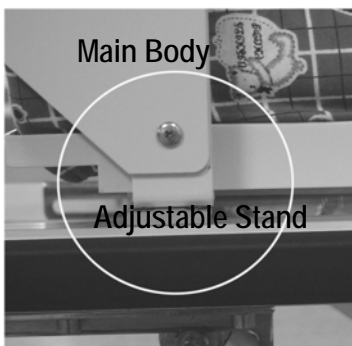
Connect the wheel



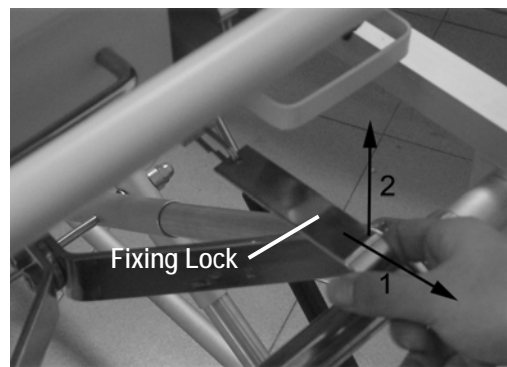
Connect the support pole

**NOTE: Two Long Support Poles must be installed closing with the side of the Height Adjustment Locking Handle when installing the Support Poles.**

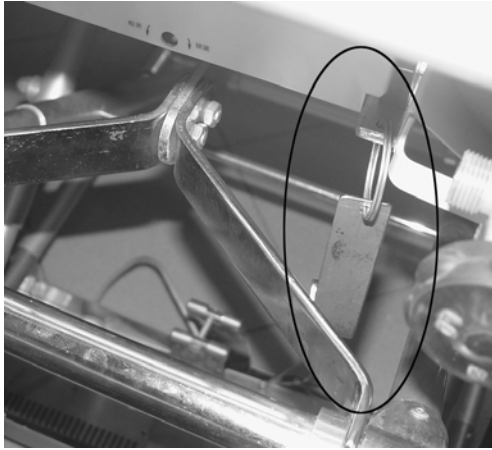
2. Place the unit box on the unit stand correctly, pull out the fixed lock as the arrow 1 indicates, and make it break away the unit stand as the arrow 2 indicates.



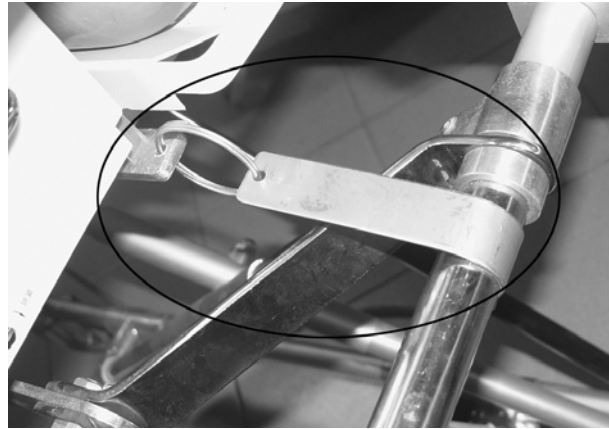
**CORRECT POSITION INSTALL MAIN BODY ONTO THE ADJUSTABLE STAND**



**LOCK THE MAIN BODY AND ADJUSTABLE STAND**



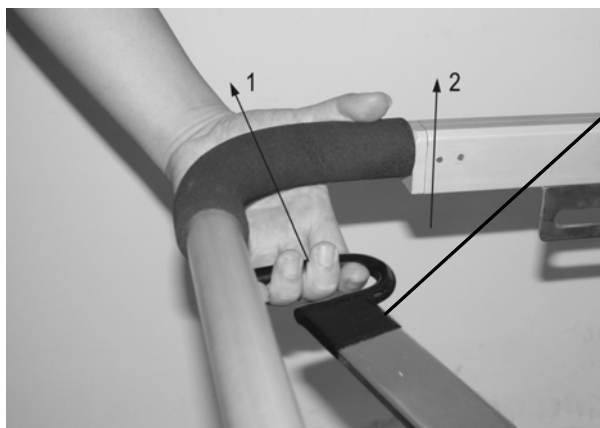
LOCKED STATUS



UNLOCKED STATUS

FIGURE 2.1 ASSEMBLING THE MAIN BODY ONTO THE ADJUSTABLE STAND

B. Refer to figure 2.2, Pull out the Height Adjustment Latch follow arrow 1, and the same time raise the Adjustable Stand toward the arrow 2, lock the Wheel of the Stand when the Unit rise the top place.

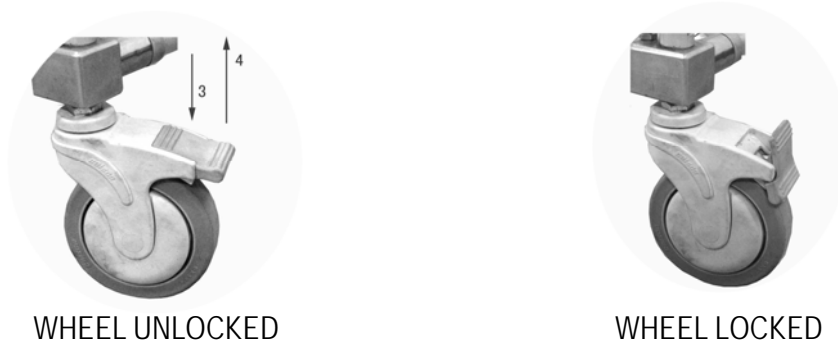


Height Adjustment Latch



Please read section 2.2 carefully when operating the unit stand.

- 1、 When placing the unit body on the stand, you must ensure that it is in the state of the fixing and locking condition (see figure 2.1) to avoid the unit body falling from the stand when moving.
- 2、 Unit stand: three steps adjustable, when adjust its height, see figure 2.2, first, pull the control pole, loosen it after giving the strength for lifting or lowering the unit stand, and then you can adjust its height. When adjust then in the right position, it will sound "ka", or else, the unit stand can not be adjusted to the right position.



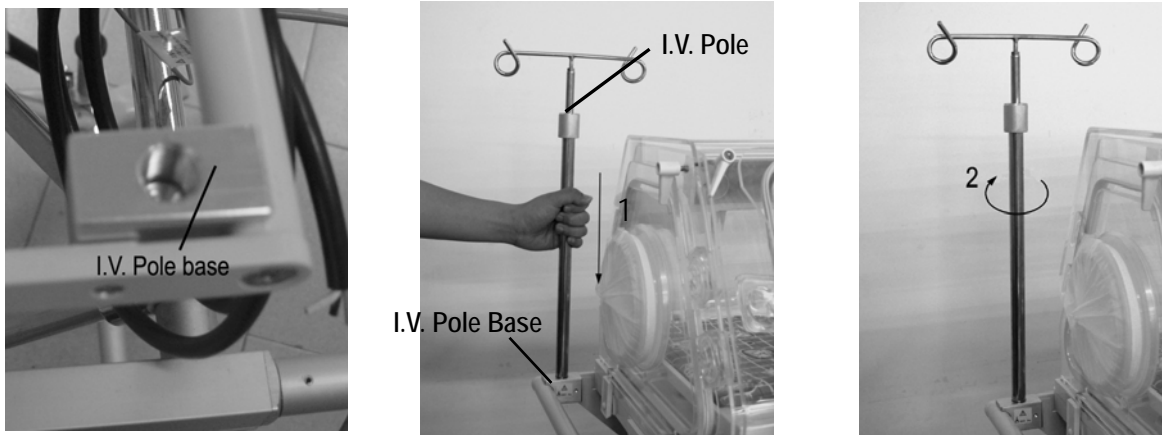
**NOTE:** The Wheels faced down as to be locked indicated by arrow 3. The Wheels faced down as to be unlocked indicated by arrow 4.

**FIGURE 2.2 RAISE THE STAND AND LOCK THE WHEEL**

**WARNING:** To prevent injury, keep fingers clear of Wheels and other moving parts.

**WARNING:** To prevent the Incubator from sliding when parked on an incline, the Stand front locking casters must be facing down the incline and locked.

C. See figure 2.3, Insert the I.V Pole into the base of I.V Pole in the way of arrow 1, and then tighten it in the way of arrow 2.



**FIGURE 2.3 INSTALL THE I.V. POLE**

**WARNING:** The Incubator must be attached to the Stand using the lock mechanism provided. Failure to do so could result in the Incubator separating from the Stand if sufficiently tilted, particularly with the Incubator transport.

**2.3 CONNECTION TO EXTERNAL POWER SOURCES**

- A. The AC Power Cord Receptacle can be connected to standard 3-wire hospital outlet.(See figure 4.1)
- B. The External DC Power Cord Receptacle should be connected with The External DC Power Cord provided, and their voltage should be according with requirement in Table 1.1. (See figure 4.1)

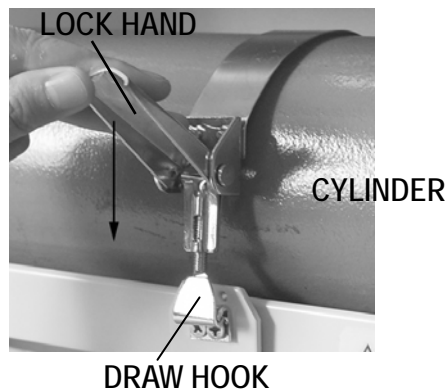
**CAUTION:** Make sure correct continuity of ground between chassis of battery and AC PLUG groundingpin before use.

To ensure grounding reliability, connect AC power cable only to a properly grounded 3-wire hospital-grade or hospital-use outlet of the proper voltage and frequency. **DO NOT USE EXTENSION CORDS.**

## 2.4 INSTALLATION OF OXYGEN CYLINDER

**WARNING:** The oxygen cylinders can become hazardous projectiles if the gas is released rapidly due to damage or other causes. Cylinders must be securely fastened to prevent movement or damage.

- A. Before attempting to install the Oxygen Cylinders, ensure that the Draw Clamp Keeper for the retaining clamp is in the proper position for the size of oxygen cylinders being mounted on the incubator.
- B. Slide the oxygen cylinder into the compartment provided after lock button connection press lock wrench toward arrow direction to fix oxygen bottle. Tighten the yokes on the cylinders; make sure the cylinders are firmly clamped (See Firgure2.4).



Cylinder must be tightening to prevent it movement.

FIGURE 2.4 TIGHTEN CYLINDER

## 2.5 CONNECTION OF REGULATOR

Refer to the figure 2.5; connect regulator with oxygen cylinder in the proper position. After connection, the oxygen pressure gauge must be placed in level.

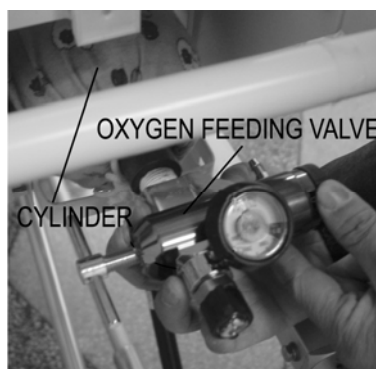


FIGURE 2.5 CONNECT OXYGEN FEEDING VALVE

## 2.6 OPERATIONAL CHECKOUT PROCEDURE

The Operational Checkout should be performed before the Incubator is first placed into service and after any disassembly for cleaning or maintenance.

### WARNING

1. Infant must be taking out from the incubator before general operation and functional checkout procedure.
2. Incubator must be stopped to use if it cannot pass the following operation checkout procedure or find any foreseeable trouble. The troubleshooting must be serviced by qualified person.
3. The checkout procedure related to temperature enable to use, only when set temperature must be high 3°C than ambient temperature.

A Check to tighten the wheels

**CAUTION:** Before mount the main body of the incubator on the stand, checkout wheels must be operated as follow. User to avoid the risk of the wheel should check the wheel regular.

Elevate each end of incubator approximately 2cm and test on each wheel one by one. A loosened wheel can result in incubator instability or tip-over while Incubator is transported. Do not use Incubator before the loosened wheel is replaced.

**IMPORTANT:** Two people are required to implement the test. One elevates Incubator and the other check the wheel. The minimum weight of Incubator to be elevated is approximately 100 kilograms.

B Check different parts of Hood and stand: Follow the procedures illustrated by figures.

Perform this Operational Checkout Procedure along with the Operational Checkout Procedure provided for the Controller before first placing the Incubator into service and after any disassembly or maintenance.

### CHECK STAND



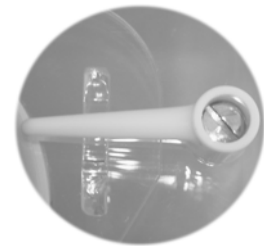
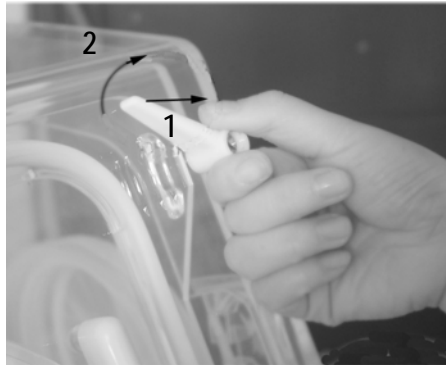
Pull out the Height Adjustment Latch follow arrow 1 and at the same time press the stand, the stand should fall down slowly until the minimum height, release the Height Adjustment Latch, it should be locked automatically. The stand should have two-step adjustable height and can lock automatically.

**NOTE:** The stand of incubator should be dropped down to the lowest height when the Incubator pushed into ambulance.

CHECK FRONT ACCESS PANEL



ACCESS PANEL LATCHE LOCKED



ACCESS PANEL LATCHE UNLOCKED

Pull and rotate access panel latches to unlocked position as same as the arrow 1 and arrow 2, open the access panel to the full open position (hanging straight down). Close the access panel and rotate both latches until they are fully engaged. Both latches must be fully engaged to prevent accidental opening of the access panel.

CHECK THE ACCESS DOOR LATCHES AND GASKETS



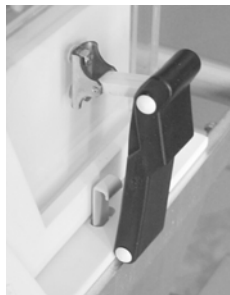
Press the door release of each access door. The access door should spring open. Check that the access door gaskets are airproof.

CHECK THE IRIS ENTRY PORTS



Rotate the outer ring of the Iris Port; the iris should open and close as rotation is continued through 360 degrees.

CHECK THE SHELL LATCHES AND HOOD RETAINERS



UNLOCKED



LOOSEN

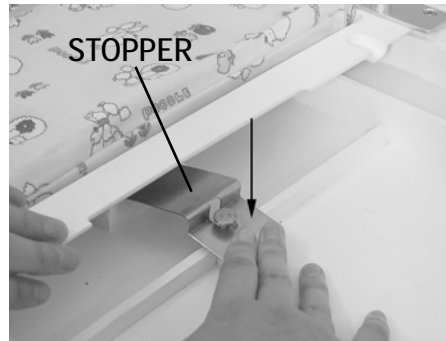
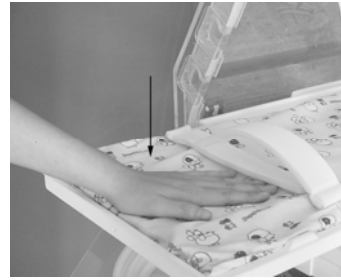


LOCKED

Check the shell latches and hood retainers. All four latches and retainers should be properly secured.



## CHECK MATTRESS TRAY



Open the Head End Access Panel and slide the tray out to the Incubator until it reaches its fully extended position indicated by the arrow. Check that the tray is stable when force is applied to extended portion. The mattress tray should be draw out while pressing the stopper beside the mattress tray as show as the arrow. Return the mattress tray and close the panels. Both latches must be fully engaged to prevent accidental opening of the access panel.

## CHECK THE AIR INTAKE MICROFILTER

**WARNING:** A dirty Air Intake Microfilter may affect oxygen concentration and /or cause Carbon Dioxide build-up. Be sure the filter is checked on a routine basis commensurate with local conditions. It must be changed at least every two months or visibly dirty.



Loosen two thumbscrews on the air filter cover and then remove the cover. Remove the filter and inspect

it; if the microfilter is visibly dirty, replace it.

CHECK THE OXYGEN SYSTEM

Connect the oxygen input valve, Introduce 8L/min oxygen, then monitor level within hood with a calibrated oxygen analyzer to verify that they reach the predicted level as indicated on the Oxygen Concentration Guide located on Incubator.

CHECK THE BOLT OF STORAGE BATTERY TRAY

After loosen the switch bolt of storage battery tray, the storage battery tray should be pulled out. After pushing back storage battery tray, tighten the switch bolt; the storage battery tray should not be pulled out.

C. Check power supply mode and check the power failure alarm

Disconnect AC power supply cord under the temperature controller turned on, the unit should be changed power supply to DC power; Disconnect DC power supply cord, the unit should be changed power supply to storage battery. Turn off the controller, loosen the bolt of storage battery tray and slide the Battery tray out approximately 5cm to disconnect the internal batteries; then turn on temperature controller again, the power fail indicator on the controller should light and a steady audible alarm should sound. The alarm should terminate automatically when the storage battery is restored.

D . Check Temperature Controller

**WARNING: The Incubator should not be used if it fails to function as described. Service should be referred to qualified personnel.**

**NOTE: Please operate the Controller according to the Manual strictly. Do not to press the key freely.**

Perform this Operational Checkout Procedure along with the Operational Checkout Procedure provided for the Hood before first placing the incubator into service and after any disassembly or maintenance.

CHECK DEVIATION ALARM (AIR MODE)

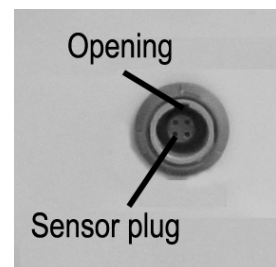
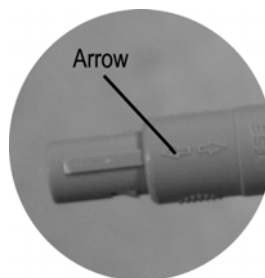
Close all of the doors, windows and set the temperature to 32 °C. Enter Temperature Alarm Checkout Status (refer to TABLE OF DEFINITIONS AND SYMBOLS). Warm up the displayed air temperature(fan warm air within the Hood) to check High Temperature Deviation Alarm (+3°C deviation alarm). Set the temperature to 35°C, Enter Temperature Alarm Checkout Status. Open the Access Panel to check Low Temperature Deviation Alarm. (-3°C deviation alarm). When High Temperature Deviation or Low Temperature Deviation

occurs, the Alarm Indicators should activate, Temperature Deviation Alarm Message **E09** or **E10** should appear on Set Temperature Display and the audible alarm should sound.

**NOTE:** This alarm will not occur until the temperature fails more than 3°C up or below set point. When checking the Low Temperature Deviation Alarm, the ambient temperature must be lower than set point or fan the air within the Hood, then the alarm will occur.

#### CHECK THE DEVIATION ALARM (SKIN MODE)

Insert the Skin Temperature Sensor into Skin Socket.



The arrow of Skin temperature sensor should aim at the gap for right insert.



1. Must handle the Sensor Plug to insert or pull out the sensor, don't pull the Sensor by the cord.
2. Never place the Skin Temperature Sensor under the Infant or use it rectally.
3. Don't bend at the joint of the sensor.

Set the Skin Set Temperature to 35°C, to Enter Temperature Alarm Checkout Status. Place the Skin Temperature Probe into trough with the temperature of over approximately 37°C or below 33°C respectively, check the Deviation Alarm of  $\pm 1^{\circ}\text{C}$ . When the Temperature High or Low Deviation Alarm occurs, the Alarm Indicators should activate, the Temperature Deviation Alarm Message **E09** or **E10** should appear on the Set Temperature Display and the audible alarm should sound.

**NOTE:** The Low Deviation Alarm will not occur until the temperature falls down 1.0°C than set point.

#### CHECK SKIN TEMPERATURE SENSOR ALARM

Select Skin Mode Control, Disconnect the Skin Sensor from the receptacle. The audible and visual alarms should activate. Set Temperature Display indicates **E04**. When the Skin Sensor reconnected, the Incubator should return to normal operation.

Select Skin Mode Control, keep Skin Temperature Sensor 2°C lower than this Set Point. The audible and visual alarms should activate when the Incubator enters temperature alarm checkout state (refer to

descriptions of terms and symbols concerned). Set Temperature Display indicates **E08**.

#### CHECK OVER TEMPERATURE ALARM

Select Air Mode of operation, in turn press UP, Down and Silence/Reset Key simultaneous, the Set Display should go blank, Heating indicators lights illuminate after Temperature Controller is put into Over Temperature Test Mode. After a while, the Over Temperature Alarm Indicator shall be activated with audible and visual. Set Temperature Display shows **E05**. Press the Silence/Reset Key, alarm is over and the Controller return to set status.

Select Skin Mode of operation, in turn press UP, Down and Silence/Reset Key simultaneous, the Set Display should go blank, Heating indicators lights illuminate after Temperature Controller is put into Over Temperature Test Mode. After a while, the Over Temperature Alarm Indicator shall be activated with audible and visual. Set Temperature Display shows **E05**. Press the Silence/Reset Key, alarm is over and the Controller return to set status.

#### CHECK FAN MOTOR FAILED ALARM

Refer to figure 5.2; raise up the Hood and take out the Mattress Tray. Hold the fan carefully and turn on the power switch of the Temperature Controller, an alarm should be occur, the fan alarm indicator flashing, Set Temperature Display will indicate **E07**, loosen the fan, the fan alarm will be canceled automatically after the fan turned. The fan should return to normal operation after pressing the Silence/Reset Key.

#### Air Temperature & Isolate Temperature Probe



**NOTE:** To avoid scalding, it must take at least 45 minutes after the incubator stopped working to perform this operation.

#### CHECK THE ACCURACY OF TEMPERATURE CONTROL

Select the air mode, and set the air temperature at 36°C, after the air temperature enters into the stable state, put the calibrated temperature measuring device on the position above 10cm from the center of mattress to measure the air temperature, compared with the indicated air temperature to check whether the deviation between them is within 1.0°C.

**CHECK DISPLAYING PRECISION OF SKIN TEMPERATURE SENSOR**

Put the mercury thermograph for the accuracy within  $\pm 0.1^{\circ}\text{C}$  into the main baby of incubator and assure the mercury ball which must be loom above center of the mattress. Choose the air mode control, set the temperature as  $36^{\circ}\text{C}$ , enter into incubator temperature equilibrium condition, read the value of the mercury thermograph, compare the value of the mercury thermograph with  $1^{\circ}\text{C}$ .

**CHECK PRECISION OF SKIN TEMPERATURE SENSOR**

Put the skin temperature sensor with the mercury thermograph for the accuracy with  $\pm 0.1^{\circ}\text{C}$  into the water cup with the temperature as  $30^{\circ}\text{C} \pm 5^{\circ}\text{C}$ . Make the probe of the skin temperature sensor and the mercury ball as closely as possible and stir enough, then read the value of mercury thermograph. Compare the value of the skin temperature sensor and the mercury thermograph, and the deviation must be within  $0.5^{\circ}\text{C}$ .

**NOTE: Please check again if the accuracy of the skin temperature sensor exceeds the permissibility deviation. Please let the professional maintenance man service machine if the accuracy the skin temperature sensor exceeds the permissibility of deviation again.**

Operation of temperature controller checkout is complete. Switch all the switches off and remove the power cord to stop using Incubator if it is not necessary to use.

## SECTION 3 TECHNICAL INFORMATION

### 3.1 SPECIFICATION

Specifications for the Incubators are provided in Table 3.1. All specifications maybe subject to change without advance notice. Open Access Doors and Front Panel, which can alter the air flow pattern, may affect temperature uniformity, temperature variability, the correlation of the Incubator temperature reading to center mattress temperature and infant skin temperature.

**TABLE 3.1      SPECIFICATIONS**

AC power.....	AC220V-230V, 50Hz
DC power.....	12V/10A, 24V/6A
Power input.....	400VA
earthed.....	Protectively earthed <math>< 0.1 \Omega</math>
Chassis leakage current.....	NC: <math>< 0.5\text{mA}</math>, SFC: <math>< 1\text{mA}</math>
Patient leakage current.....	Normal Condition <math>< 0.1\text{mA}</math> Single Fault Condition: <math>< 0.5\text{mA}</math>
Patient leakage current (Mains Voltage On The Applied Part ) .....	Single Fault Condition: <math>< 5\text{mA}</math>
<b>With respect to IEC601-1, this equipment is Class I, Type BF. Internally powered equipment.</b>	
<b>INTERNAL BATTERY SPECIFICATIONS</b>	
Type.....	Topin®TP12-26(12V26AH/20HR)Battery
Quantity.....	One
Voltage.....	12V/26AH
Charge Time (full discharge).....	10 Hours
Life Expectancy.....	200times complete charge/discharge cycles
Operating Time at temperature equilibrium .....	90min
(Set Temp 36°C — Ambient 15°C)	(1battery)
Battery length.....	16cm
Battery width.....	17cm
Battery height.....	13cm
Battery weight.....	9Kg
<b>ENVIRONMENTAL TEMPERATURE (Normal)</b>	
Operating Range.....	+10°C ~ +30°C
(NOTE: The Incubator set point must be at least 3°C higher than ambient.)	
Operating Range(Limited).....	+0°C ~ +40°C
Storage Range.....	-40°C ~ +70°C

**TABLE 3.1 SPECIFICATIONS (Continued)**

<b>ENVIRONMENTAL HUMIDITY</b>	
Operating Range	30%~75%RH Non-Condensing
Storage Range	≤93% RH Non-Condensing
<b>ATMOSPHERIC PRESSURE</b>	
Shipment and storage atmospheric pressure range	500hPa~1060hPa
Operating atmosphere pressure range	700hPa~1060hPa
<b>THE AIR FLOW RATE</b>	
Ambient air flow rate	<1.0m/s
<b>TEMPERATURE CONTROL RANGE AND CORRELATIVE SPECIFICATION</b>	
Air Mode Control	25~37°C 37.0 to 38.0°C, Temperature Override Mode
Skin Mode Control	34~37°C 37.0 to 37.5°C, Temperature Override Mode
Temperature Rise Time**(22°C ambient )	≤30minutes
Temperature Variability **	≤1°C
Temperature Uniformity**(level mattress)	≤1.5°C
Correlation of Indicated Air Temperature to Actual Incubator Temperature ** (After Incubator Temperature Equilibrium** is reached)	≤0.7°C
Skin Temperature Sensor Accuracy	≤0.3°C
Deviation between the indicated air temperature and the real temperature (under the steady temperature condition)	≤1.0°C
<b>ALARM (SEE SECTION 3.2)</b>	
<b>General Power alarm</b>	
Air temperature sensor failure	Alarm code E01
The isolated air sensor failure	Alarm code E0.2
Deviation of air and isolated sensor failure	Alarm code E0.3
Skin temperature sensor failure	Alarm code E0.4
Over-temp failure	Alarm code E0.5
Motor stop	Alarm code E0.6
Motor retard	Alarm code E0.7
Wrong position of skin sensor failure	Alarm code E0.8
High deviation alarm	Alarm code E0.9
Low deviation alarm	Alarm code E1.0
Low Voltage Alarm	Alarm code E1.1
Internal system failure	Alarm code H0.1~H1.3

**TABLE 3.1 SPECIFICATIONS (Continued)**

<b>PHYSICAL DIMENSIONS</b>	
Height From Top To Floor(Highest Position In Stand).....	128cm
Height From Top To Floor(Lowest Position In Stand).....	100cm
Length.....	170cm
Width.....	50cm
Incubator Main body Weight (Including Incubator and one Battery).....	65Kg
Adjustable Stand Weight.....	29Kg
IV Pole Max. Load.....	20N
Infant Mattress Max. Load.....	98N
Infant Mattress Width.....	35cm
Infant Mattress Length.....	63cm
<b>OTHER SPECIFICATION</b>	
Noise Level Within Hood Environment.....	<60dBA
	(Base on surrounding environment noise below 50dBA)
Carbon Dioxide (CO <sub>2</sub> ) Level Within The Hood.....	Less than 0.5% when a mixture of 4% CO <sub>2</sub> in air is delivered at 750ml/min at a point 10 cm above the center of the mattress.
Air Velocity Over Mattress.....	Less than 0.35 m/s
<b>SILENCE / RESET KEY</b>	
When the following alarm occurs, press SILENCE/ RESET key to silence the alarm for 5 minutes, the alarm will come back automatically after 5 minutes. If alarm condition no longer exists, the alarm will be canceled (except overheat); or press the SILENCE/ RESET key twice to cancel the alarm, the equipment will come back to set state.	
<ul style="list-style-type: none"> <li>. Sensor failure alarm</li> <li>. Motor failed alarm</li> <li>. Temperature deviation alarm</li> <li>. Overheat alarm</li> <li>. Low voltage alarm</li> </ul>	
The life span of transport incubator is 8 years, here, life span means the period from sell-by date to the date of discarding as useless.	
* Skin control mode.	
** Refer to definitions and symbols.	
<b>NOTE: Open Access Doors or Panel or the use of supplies or other equipment within the incubator, which can alter the air flow pattern, may affect temperature uniformity, temperature variability, the correlation of the incubator temperature reading to center mattress temperature and skin temperature.</b>	



## 3.2 WORKING PRINCIPLE

### 3.2.1 General

This section contains a functional description and detailed theory of operation of the equipment. A system block diagram of the Controller is shown in Figure 3.2 and 3.3.

Temperature control can carry through the air-circulation system as figure 3.1. After the air outside is purified and is filtrated, it can go into the constant temperature hood from the air-intake of the incubator through the fan driving, and then recycle to the fan by place with a draught. All fresh and recycling air are led through nearby the airflow sensor and heater. The air can pass through the sensor equipped with probe of temperature sensor, which includes themistor of air temperature control and themistor of over-air-temp alarm.

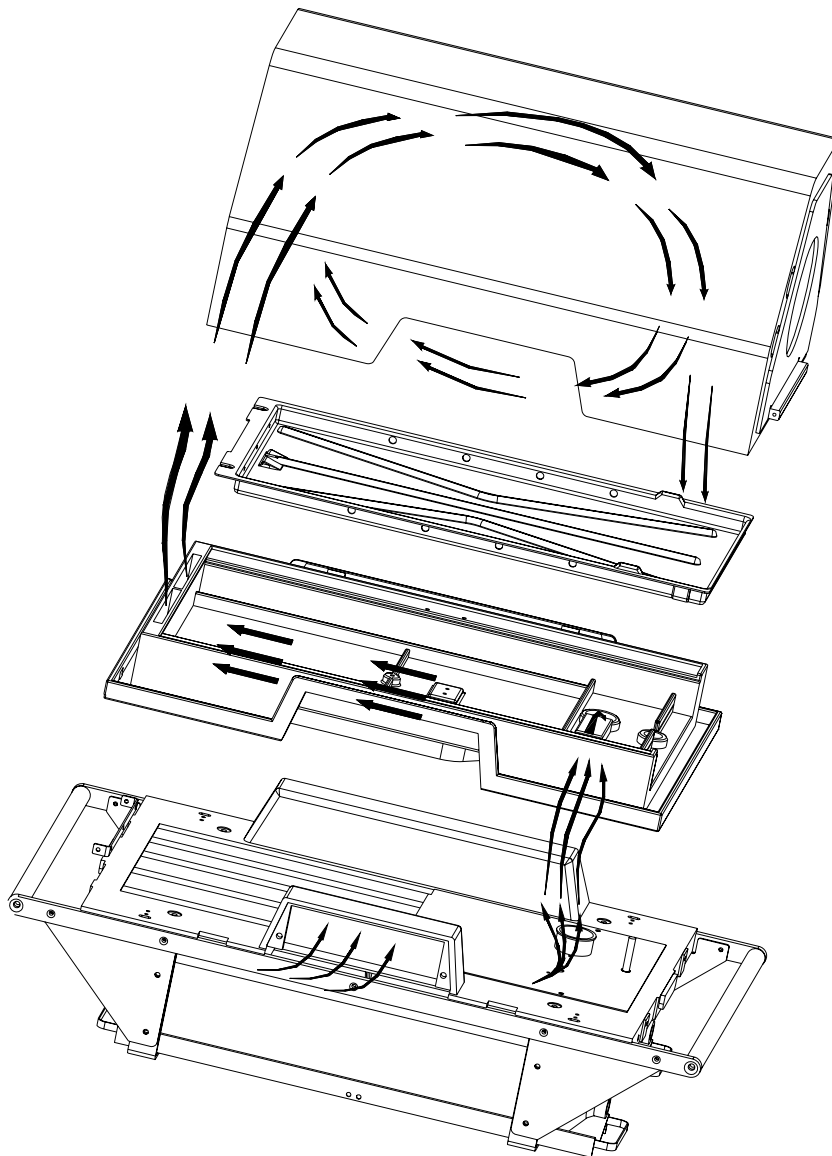


FIGURE 3.1 AIR CIRCULATION SYSTEM

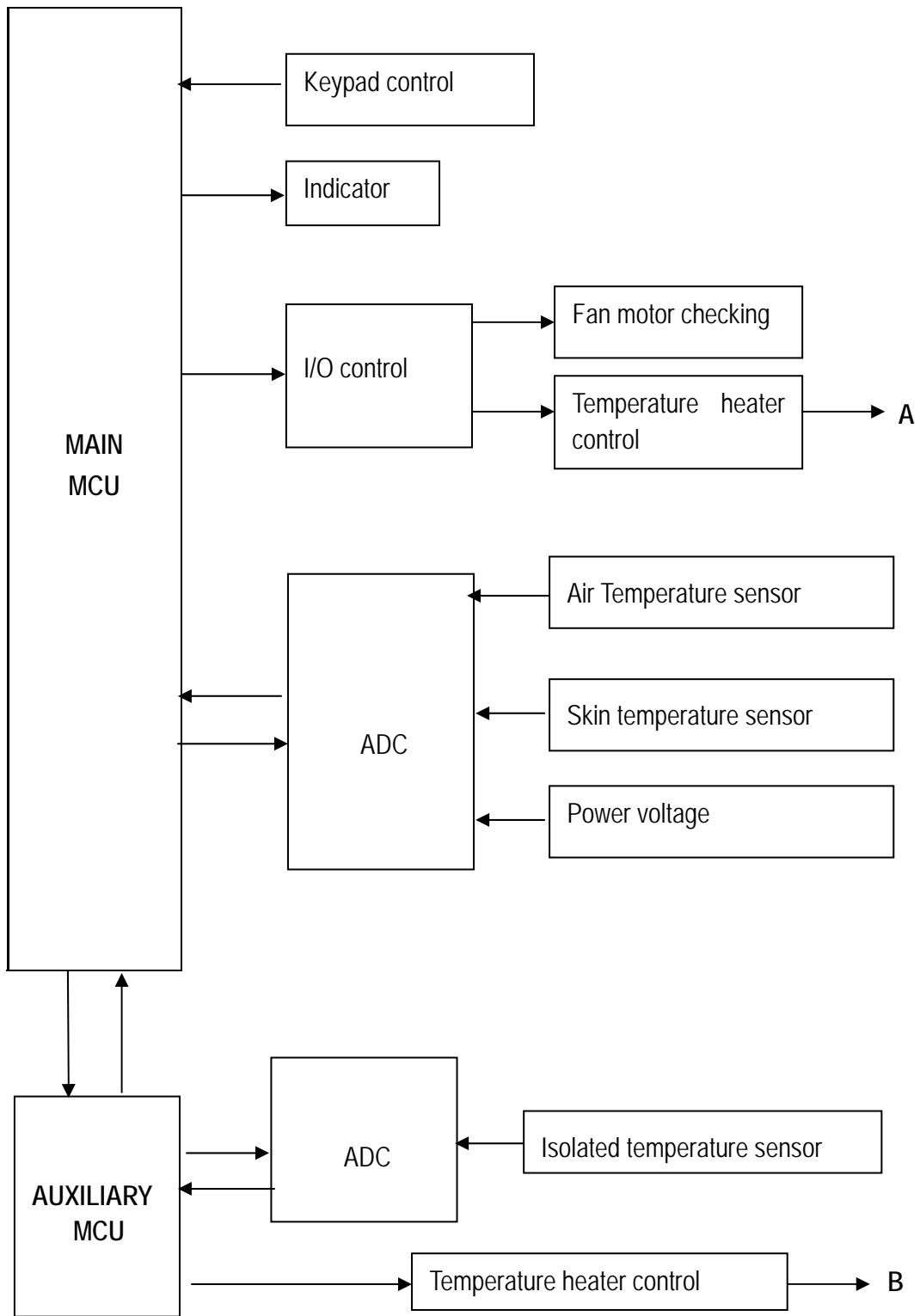


FIGURE 3.2 CONTROL DIAGRAM

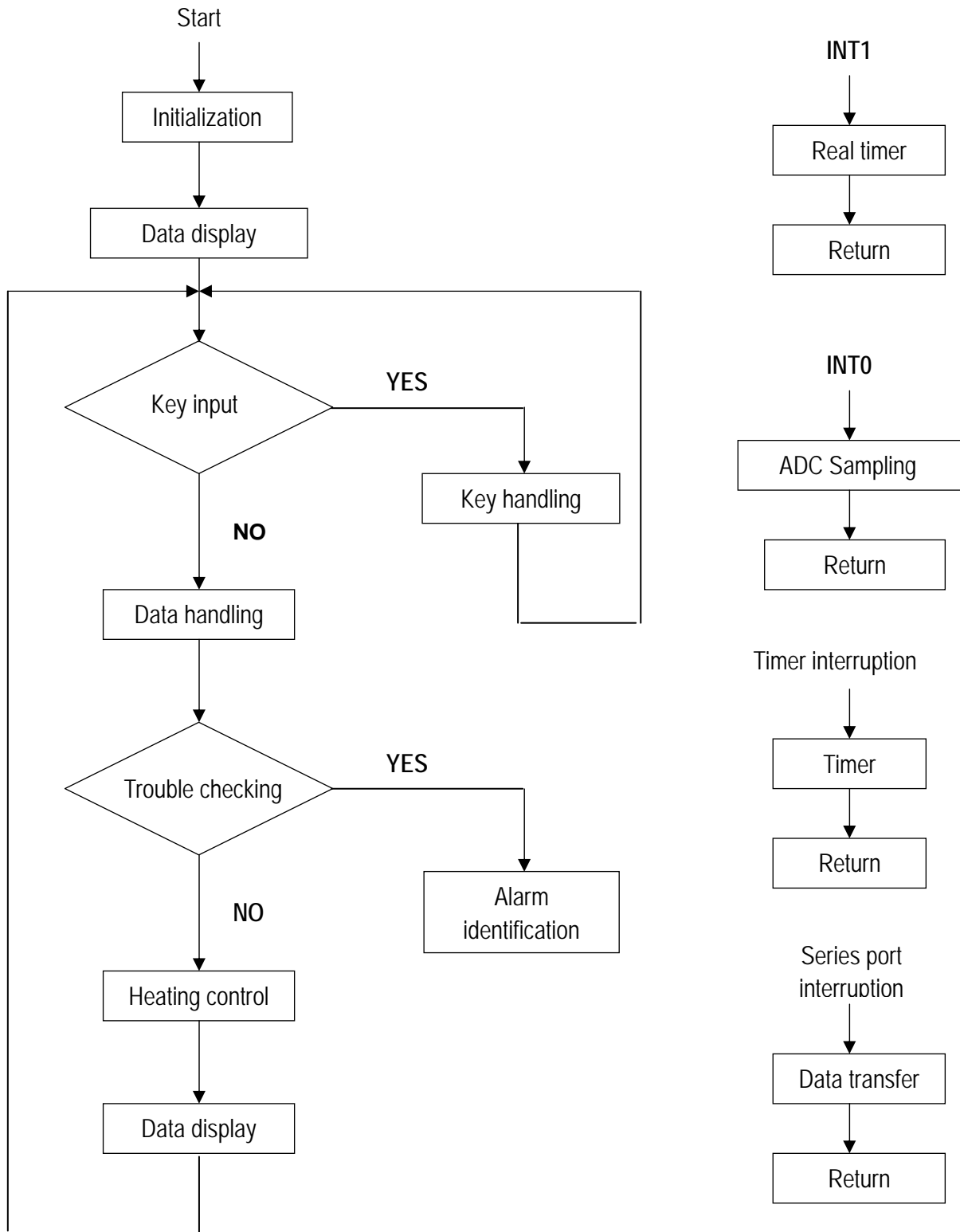


FIGURE 3.3 FLOW CHART OF PROGRAMME

### 3.2.2 Temperature Control

Temperature is regulated using either incubator Air or Skin temperature as the controlling parameter; the desired mode is selected by the front panel keys.

In either mode of operation, the heater output is proportional to the amount of heat required to maintain the desired temperature. In air mode, the air temperature can be maintained from 25 to 37°C (over-ride mode: 37~38°C ). A sensor located in the Sensor Module and compared with Air Set Temperature setting monitors air temperature. The information from this sensor is supplied to heater control circuitry which regulates the heater output to maintain the Air Temperature setting. In the event that over temperature limit is activated, the heater is shut off. Under this control mode, skin display window will display the temperature on the skin temperature sensor; if the skin temperature sensor isn't inserted, the skin display window will display "--. -".

In skin mode, the infant's temperature can be selected from 34.0 to 37.0°C (over-ride mode: 37~37.5°C ). A temperature sensor is attached directly to the infant's skin; the information from the sensor is supplied to the heater control circuitry, which proportions the heater output to maintain the Skin Set Temperature. In Skin Temperature Mode, the Skin Temperature will be displayed on Skin Temperature Display Window; the Air Temperature Display Window will display the Air Temperature for information only. A second sensor within the air temperature sensor serves as a backup to limit the maximum Incubator temperature. In the event that over temperature limit is activated, the heater is shut off.

### 3.2.3 Alarms

Alarm is used for monitoring the temperature control system state. The system will check the state by the alarm checkout procedure. When the checked data is abnormal, it will alarm. Table 3.2 listed alarm condition.

**TABLE 3.2 ALARM**

ALARM MESSAGE		DESCRIPTION
Power Failure indicator is on		If the mains power supply fails or no power supply, the power alarm with audible and visual will active.
Sensor Alarm indicator is on	Code E0.1	In air mode, If short-circuit or open-circuit or bad connection occurs on the air temperature sensor, at the same time, heater stops working, press Silence/Reset Key to clear alarming for 5min, please refer to the service part.
	Code E0.2	If short-circuit or open-circuit or bad connection occurs on the isolated temperature sensor, at the same time, heater stops working, press Silence/Reset Key to clear alarming for 5min, please refer to the service part.
	Code E0.3	If the deviation between the air temperature and isolated temperature sensor is more than 0.8°C, at the same time, heater stops working, press Silence/Reset Key to clear alarming for 5min, please refer to the service part.

TABLE 3.2 ALARM

ALARM MESSAGE		DESCRIPTION
Over-Temp Alarm indicator is on	Code E0.4	In baby mode, If short-circuit or open-circuit or bad connection occurs on the skin temperature sensor, at the same time, heater stops working, press Silence/Reset Key to clear alarming for 5min, please refer to the service part.
	Code E0.5	In the air mode, when the incubator temperature is less than 38°C (set temperature <37°C) or less than 40°C(set temperature >37°C), at the same time, heater stops working, press Silence/Reset Key to clear alarming for 5min, it can not reset after clearing the failure, press Silence/Reset Key to clear alarming
		In the Baby mode, when the incubator temperature is less than 40°C, at the same time, heater stops working, press Silence/Reset Key to clear alarming for 5min, it can not reset after clearing the failure, press Silence/Reset Key to clear alarming
Fan alarm indicator is on	Code E0.6	When the fan motor stops working, at the same time, heater stops working, press Silence/Reset Key to clear alarming for 5min, please refer to the service part.
	Code E0.7	When the wind speed is lower than 1000rpm, at the same time, heater stops working, press Silence/Reset Key to clear alarming for 5min, please refer to the service part.
Sensor Alarm indicator is on	Code E0.8	In baby mode, If the temperature of skin temperature sensor is always lower 2°C than the set temperature or more, heater stops working, press Silence/Reset Key to clear alarming for 5min, it can reset when the failure does not exist.
HIGH Deviation Alarm indicator is on	Code E0.9	In air mode, If the air temperature is higher 3°C than the set temperature, heater stops working, press Silence/Reset Key to clear alarming for 5min, it can reset when the failure does not exist.
		In baby mode, If the skin temperature is higher 1°C than the set temperature, heater stops working, press Silence/Reset Key to clear alarming for 5min, it can reset when the failure does not exist.
LOW Deviation Alarm indicator is on	Code E1.0	In air mode, If the air temperature is lower 3°C than the set temperature. At this time, the heater keeps working, press Silence/Reset Key to clear alarming for 5min, it can reset when the failure does not exist.
		In baby mode, If the skin temperature is lower 1°C than the set temperature, heater stops working, press Silence/Reset Key to clear alarming for 5min, it can reset when the failure does not exist.
Low Voltage Alarm Indicator is on	Code E1.1	The incubator 12V dc power source or the battery supplies below 10.5V and/or 24V DC power source supply below 22.5V, at the same time, heater stops working, press Silence/Reset Key to clear alarming for 5min, please refer to the service part.

TABLE 3.2 ALARM

ALARM MESSAGE		DESCRIPTION
The system indicator is on	Code H0.1	ROM inside of the main MCU failed, at the same time, heater stops working, press Silence/Reset Key to clear alarming for 5min, please refer to the service part.
	CodeH0.2	If the internal system of main MCU is error, at the same time, heater stops working, press Silence/Reset Key to clear alarming for 5min, please refer to the service part.
	Code H0.3	If the communication between the main MCU and the auxiliary MCU A is error, at the same time, heater stops working, press Silence/Reset Key to clear alarming for 5min, please refer to the service part.
	Code H0.4	ROM inside of the auxiliary MCU failed, at the same time, heater stops working, press Silence/Reset Key to clear alarming for 5min, please refer to the service part.
	Code H0.5	If the internal system of auxiliary MCU is error, at the same time, heater stops working, press Silence/Reset Key to clear alarming for 5min, please refer to the service part.
	Code H0.6	E <sup>2</sup> PROM inside of the main controller failed, at the same time, heater stops working, press Silence/Reset Key to clear alarming for 5min, please refer to the service part.
	Code H0.7	ADC failure outside main MCU (e.g., auxiliary system TLV2548, including wrong sample, chip damage, no response and so on).at the same time, heater stops working, press Silence/Reset Key to clear alarming for 5min, please refer to the service part.
	Code H0.8	ADC failure outside auxiliary MCU (e.g., auxiliary system TLV2548, including wrong sample, chip damage, no response and so on).at the same time, heater stops working, press Silence/Reset Key to clear alarming for 5min, please refer to the service part.
	Code H0.9	Heating electric circuit failure (e.g. heating device, solid relay, mechanism relay and their seprate controlling circuit failure). At the same time, heater stops working, press Silence/Reset Key to clear alarming for 5min, please refer to the service part.
	Code H1.0	Power voltage overlarge failure (when the power supply for the battery larger than 15.5V, for DC12V larger than 14.5V or for DC24V is larger than 28.5V, and the output voltage for power switch is larger than 17.0V). At the same time, heater stops working, press Silence/Reset Key to clear alarming for 5min, please refer to the service part.
	Code H1.1	Short circuit happens when pressing keys on keyboard, at the same time, heater stops working, press Silence/Reset Key to clear alarming for 5min, please refer to the service part.
	Code H1.2	Battery failure. The rechargeable battery inside of the controller nconnected, dropped or short-circuit failure. At the same time, heater stops working, press Silence/Reset Key to clear alarming for 5min, please refer to the service part.
	Code H1.3	When there is malfunction in the connecting parts between the storage battery and the power box, at the same time, heater stops working, press Silence/Reset Key to clear alarming for 5min, please refer to the service part.

## SECTION 4

### PREVENTIVE MAINTENANCE

#### 4.1 GENERAL

The Section provides cleaning and maintenance instructions. Where necessary, disassembly Instructions are provided. Only qualified service personnel should perform maintenance other than that provided in this section. Routinely inspect patient compartment for signs of breakage and replace assemblies before placing Incubator into service.

**WARNING:** Make sure that all connections to the Incubator is disconnected, especially with the oxygen supply when performing cleaning and maintenance procedures; a fire and explosion hazard exists when performing cleaning and /or maintenance procedures in an oxygen enriched environment.

#### 4.2 CLEANING

It is recommended that when an infant is discharged, or at least once a week, to thoroughly clean and disinfect the incubator. Clean and disinfect must be performed when used firstly. It did not disinfect when the Incubator was handed over to user. The most effective way to clean is to first disassemble, and then group the parts and assemblies in categories according to the method of cleaning required. The rechargeable battery should be replaced every three years.

**WARNING:** Infant must be taken out of the incubator before cleaning.

##### 4.2.1 DISASSEMBLY FOR CLEANING

**NOTE:** For routine cleaning there is no need to separate the Hood assembly from the stand. If separation is necessary, refer to the Installation Section.

1. Turn off the Main Power Switch and remove the Power Cord. Remove the Access Door Cuffs, Gaskets, Iris Entry Port sleeves and Soft Port for IV.
2. Disconnect the cables from the Sensor Module and remove the I.V pole. Open the Hood Retainers, take out the Hood and Inner Wall as show as Figure 4.1.

**CAUTION:** Before lifting Incubator Hood for cleaning, ensure that all mounted accessories have been removed to prevent possible interference with the raised Hood.

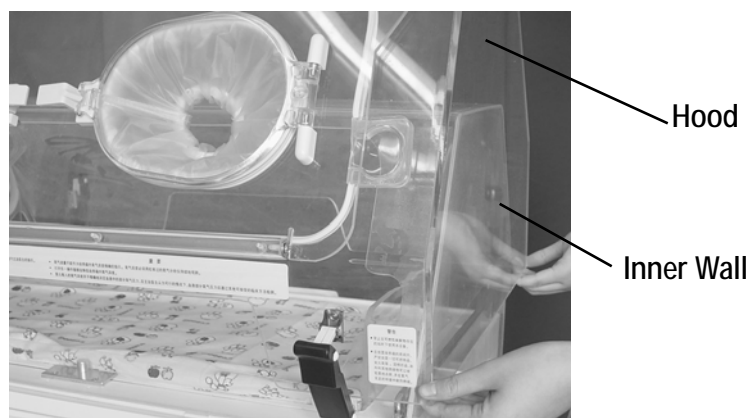
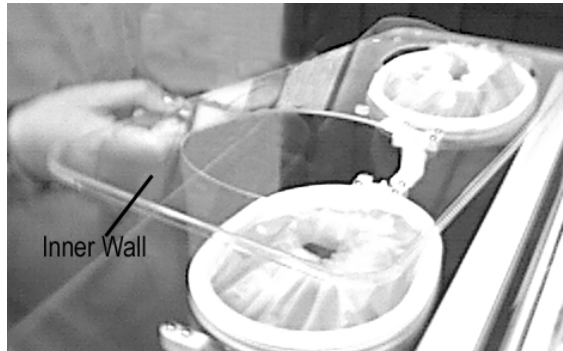


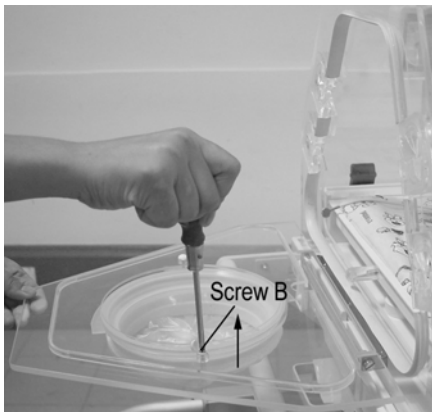
FIGURE 4.1 REMOVING THE HOOD AND INNER WALL



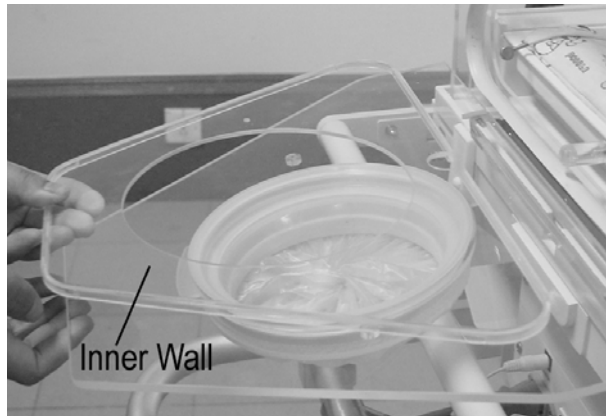
UNSCREW SCREW "A" AS ARROW DIRECTION



TAKE OUT THE INNER WALL OF THE FRONT DOOR



UNSCREW SCREW "B" AS ARROW DIRECTION

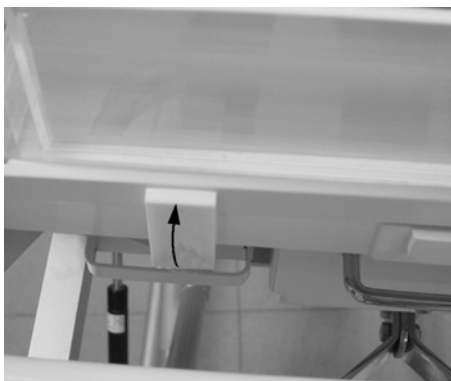


TAKE OUT THE INNER WALL OF THE SIDE DOOR


**FIGURE 4.2 REMOVING THE INNER WALL**

3. Slide the mattress tray and take out the humidity sponge. (Refer to paragraph 2.6 B).

4. See figure 4.3, pull the connecting lock of main deck outwards as the arrow indicates to take out the main deck.



RAISE OUT THE MAIN DECK

 It must be cooling for 30 minutes to touch the heater; operation should be sufficiently care avoiding scald.

**FIGURE 4.3 RELEASE THE MAIN DECK LATCHES AND RAISE OUT THE MAIN DECK**

5. Loosen the two screws off the Air Filter Cover and remove the Air Filter. (Refer to Paragraph 2.6 B)



## 4.2.2 CLEANING AFTER DISASSEMBLY

### A. CLEANING AGENTS

Use an intermediate level detergent /disinfectant registered by country, but only after the Incubator is empty and disassembled as described in Paragraph 4.2.1. When using any cleaning agent, follow the cleaning agents manufacture's direction for use. After removing all solid wastes and contaminants from the disassembled parts, clean them as follows.

### B. SKIN TEMPERATURE PROBE

Use a registered detergent/disinfectant to thoroughly clean all surfaces, and then dry with a clean cloth or paper towel. Do not place the Probe into detergent/disinfectant.

### C. TUBING ACCESS PORTS, ACCESS DOOR CUFF AND GASKETS

Place them into a suitable container filled with detergent/disinfectant. Allow them to soak as recommended by the cleaning solution's manufacture, then remove and wash them with distilled water and dry completely with a clean cloth or paper towel.

### D. CONTROLLER, SHELL AND STAND

**CAUTION:** When cleaning the Incubator Shell, care must be taken to prevent liquids from entering.

Remove any lint build-up on the heater radiator and fan impeller. Use a registered detergent/disinfectant to clean all surfaces thoroughly, and then dry with a clean cloth or paper towel, and then be especially careful when cleaning fan, heater and surface of air temperature sensor. Then dry them with clean cloth.

**CAUTION:** Some chemical cleaning agents may be conductive and/or leave a residue which may permit a build-up of dust or dirty which may be conductive. Do not permit cleaning agents to contact electrical components. Do not spray cleaning solutions onto any of these surfaces.  
Failure to clean the Fan Impeller could result in sufficient lint build-up to reduce airflow, which will affect temperature control and cause high carbon dioxide concentration.

### E. HOOD AND INNER WALLS

Use a registered detergent to clean all surfaces of the hood thoroughly, including the holes, indentations, all access doors and access panel. Make sure to clean all holes and indentations, and then dry with a clean cloth or paper towel.

**CAUTION:** Alcohol can cause crazing of the clear Acrylic Hood. Do not use alcohol for cleaning.

Do not expose the hood assembly to direct radiation from germicidal lamps. Ultraviolet radiation from this source can cause cracking of gaskets, fading of paint, and crazing of the clear Acrylic Hood.

## F. MATTRESS, HUMIDITY SPONGE, MATTRESS TRAY AND MAIN DECK

Use a registered detergent/disinfectant to clean all surfaces thoroughly including the indentations; then dry with a clean cloth or paper towel. Take off humidity sponge and mattress cover to wash with a registered detergent/disinfectant, then washing with clean water and dry under sunlight.

## G. AIR INTAKE MICROFILTER

Do not attempt to clean or reverse the Microfilter. Replace it if visibly dirty or older than 2 months. Before install a new filter, clean the Microfilter Chamber and Cover with the detergent/ disinfectant.

**WARNING: A dirty inlet filter may affect oxygen concentration and/or cause carbon dioxide build-up. Be sure the filter is checked on a routine basis commensurate with local conditions.**

## H. TROLLEY

Use a disinfectant-detergent to clean all surfaces of the trolley and dry with a clean cloth or paper towel.

**CAUTION: Do not lubricate the mattress tray stopper with lubricating oil or other combustibles.**

### 4.2.3 REASSEMBLY AFTER CLEANING

**NOTE: Inspect all cleaned components for any breakage or cracks before reassembling into the Incubator. Harsh cleaning agents may attack some of the plastics used in the Patient Compartment.**

A. Place the Main Deck, the Mattress Tray, the Mattress and the Hood.

B. Visually and physically examine the mattress for any holes or cuts that will permit the entry of fluids onto the inner foam. If the mattress is damaged, it should be replaced.

C. Install the Access Door Gasket and Cuff, and as shown in Figure 4.4.



INSTALLATION OF ACCESS DOOR GASKET



INSTALLATION OF ACCESS DOOR CUFF

**FIGURE 4.4 INSTALL ACCESS DOOR GASKET AND ACCESS DOOR CUFF**

**NOTE: If the Incubator is to be gas sterilized, wait until after sterilization to install new cuffs.**

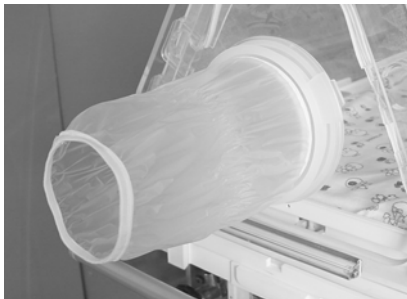
If the Access Door Gasket is too hard and difficult installation, please place them into warm water before installation.

D. Install tubing access ports as shown in Figure 4.5. If damaged, please replace them. **(NOTE: The flat surface of tubing access ports is outside.)**

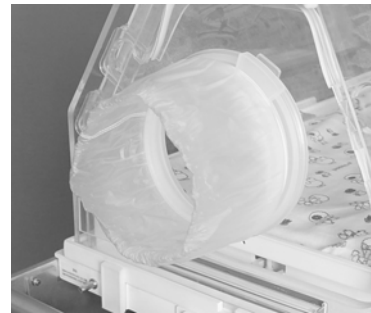


**FIGURE 4.5 INSTALL TUBING ACCESS PORTS**

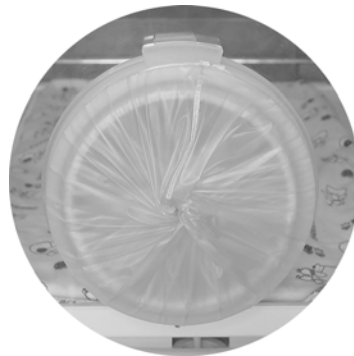
E. Install the Iris Entry Port Plastic sleeves and Gaskets (see Figure 4.6). Replace them if they are already damaged.



Install the smaller diameter elastic band of a new Sleeve over the inner ring of the port housing.



Fold back and slip elastic band over The outer ring of the port housing.



Rotate outer ring to close. If properly installed, the sleeve will open again if rotation is reversed.

**FIGURE 4.6 INSTALLATION OF IRIS ENTRY PORT SLEEVE**

F. Install an Air Intake Micro filter.

Refer to the Paragraph 2.6, Step B, place the Air Intake Micro filter into the Cover and tighten the two thumbscrews. Install the air intake micro filter.

**IMPORTANT: A complete functional checkout procedure should be performed after the incubator finished installation.**

### 4.3 GAS STERILIZATION

Prior to gas sterilization, the entire Incubator should be thoroughly cleaned as described elsewhere in this section. All parts need to be replaced such as iris sleeves, air filter materials, etc. should be removed. New replacement parts should be installed after sterilization.

**ATTENTION:** During gas sterilization, Temperature Controller must be removed to avoid hazards. Clean the Temperature Controller according to section 4.2.

**CAUTION:** Sterilization temperature should not exceed 54.5°C.

Upon completion of gas sterilization, an aeration period of 16 to 24 hours should be allowed. The controller should be properly secured in place and the Incubator should be operated in a dry condition for the entire period of aeration at a temperature of 32 to 35°C. After aeration, if the unit is not to be used immediately, a disposable dust cover should be placed on the Incubator.

**IMPORTANT:** A complete functional checkout procedure should be performed before the incubator use.

## SECTION 5 MAINTENANCE

### 5.1 INTRODUCTION

This section provides the replacement of the inner battery, the set procedure of the control and the procedure of trouble-shooting.

### 5.2 REPLACEMENT OF INNER BATTERY AND FUSE

See figure5.1, unscrew the bolts on the cover of the power board and the bolt for fixing the power board, take out the upper cover, disconnect all the wiring plugs on the control board, take out the temperature control. you can replace the inner battery and inner fuse.

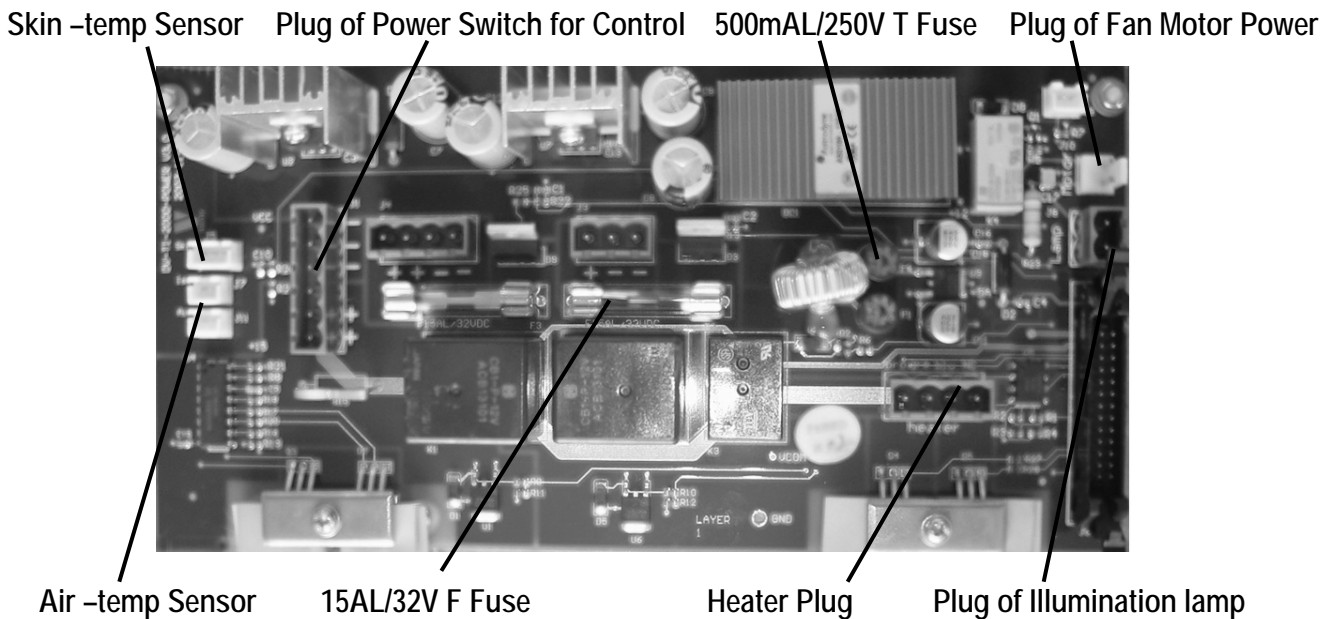


FIGURE 5.1 THE DISTRIBUTION OF INNER FUSE AND ALL CONNECTION PLUG

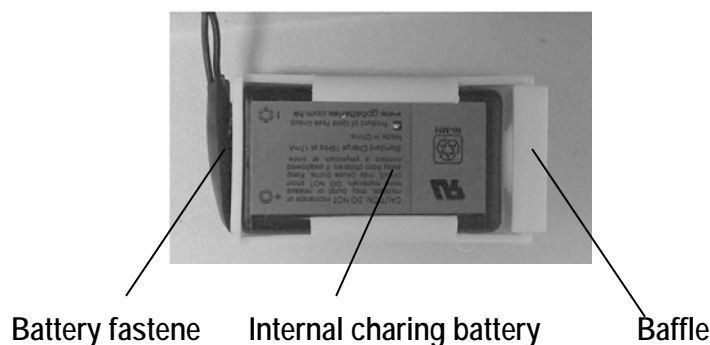


FIGURE 5.2 THE DISTRIBUTION OF RECHARGABLE BATTERY AND BATTERY PROTECTION FUSE

- NOTE: 1. During replacing the internal battery, the plastic washer should be placed the original position, and keep correct connection between the anode/ cathode of battery and its fastener; the faulty connection will cause the damage to the battery and no hont for power failure alarm.
2. Please replace theb internal battery after using it for three years.
3. Battery will be automatically charged when the temperature controller works, charging the battery outside of the incubator is forbidden.

4. The charging battery inside the wartmer is GP17R8H Ni-MH8.4V/170mAh, to ensure safety, do not disassemble battery. Connect the battery correctly, do not use other type battery.
5. It will not influence battery charging and the battery capacity when the battery is full. (Switch on controller)
6. Please do not throw the old battery into fire or water to avoid explosion or leakage.
7. Please dispose the Old battery accoring to local law, and please do not throw them away randomly.

### 5.3 REPLACEMENT OUTER FUSE

A. Figure 5.3, open the cover of fuse to replace the fuse.



FIGURE5.3 REPLACE THE FUSE

**NOTE:** When replacing the fuse, first cut off the power supply and pull off the power cord.

B. Replacement of illumination lamp

If the partial part of LED is not on, you must change the whole LED board; if the whole part of LED is not on, check the voltage of illumination lamp and the power supply offering is DC12V; if the voltage of illumination lamp and the power supply offering is DC12V, check the connecting condition of illumination lamp socket and power output condition.

### 5.4 MAINTENANCE AND REPLACEMENT AND THE STORAGE BATTERY

A. Maintenance of the storage battery.

**NOTE:** Before checking, use AC power to recharge the storage battery for 24 hours, disconnect the connection of AC power until the battery is full.

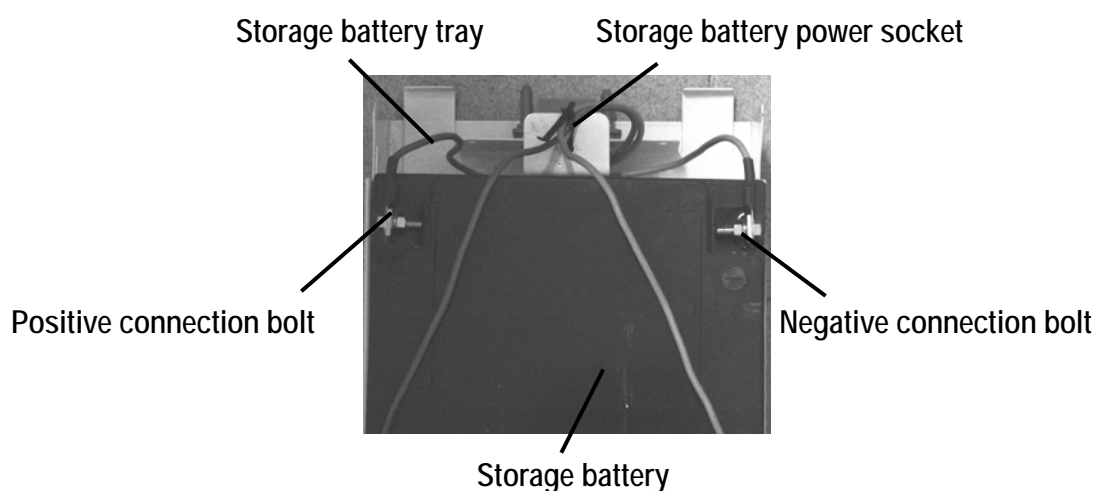
If using the incubator for first time, please check the capacity of the storage battery as the following methods: every three months:

1. place the incubator in the room of about 20°C, open all doors, windows, disconnect the connection of AC power and DC power;
2. the incubator is working in the mode of the air-temp, the maximum of set value of temperature is 37°C;
3. Before the low-voltage alarm, the incubator should work continuously at least 90 min; if can not reach 90 min, please replace the storage battery.
4. After finishing the above checking, the battery should be charged for 24 hours continuously.

B. Recharge the storage battery: Connect AC power cord and turn on the power switch, Incubator will operate at AC power supply mode. The storage battery will be charged automatically when the controller is operating. The Storage Battery Capacity Indicator will display the Storage Battery Capacity, 100% will be display that the Storage Battery Capacity is full.

**NOTICE:** If AC power failed and other AC power is not supply during the Method, the power supply of the Incubator should automatically be changed to the Storage Battery. The Storage Battery should be changed to charging status from supply status.

C. Replacement of the storage battery



Turn out positive and negative connection bolt of the storage battery to replace it.

**FIGURE 5.4 REPLACEMENT OF STORAGE BATTERY**

**NOTE**

1. The replacement of storage battery should be done by the professional personnel.
2. Reconnect positive and negative wire of the storage battery, the brown wire should be connected to positive of the storage battery and the blue wire to negative.
3. The damage of the socket of storage battery electricity-offer is forbidden. We suggest to use type Topin®TP12-26 and storage battery electricity-offer 12V/26AH.
4. The storage battery can only recharge when the temperature control is working, you should take it out to recharge by yourself.
5. Recharge it when the storage battery is full (turn on the switch of the temperature control), it will not affect the capacity of the storage battery.
6. Throwing the useless battery into the fire or water is forbidden to avoid explosion or liquid leaking.
7. The useless battery should not be discarded at will, should be dealt with according to the law of the nation.
8. When the device enters into the battery protection mode, (the power failure light is on, any other light will not give any indication and audible tips), the user must recharge it or turn off the device at once to avoid affecting the life-span of the storage battery.

## 5.5 SYSTEM SET PROCEDURE

### 5.5.1 Introduction

This section offers the set procedure of temperature control, which is used by the qualified personnel.

**NOTE:** Please operate according to the steps in section 5.5.2 do not amend the data of this procedure in avoid the unexpected danger.

### 5.5.2 Brief introduction

System set procedure includes the following contents:

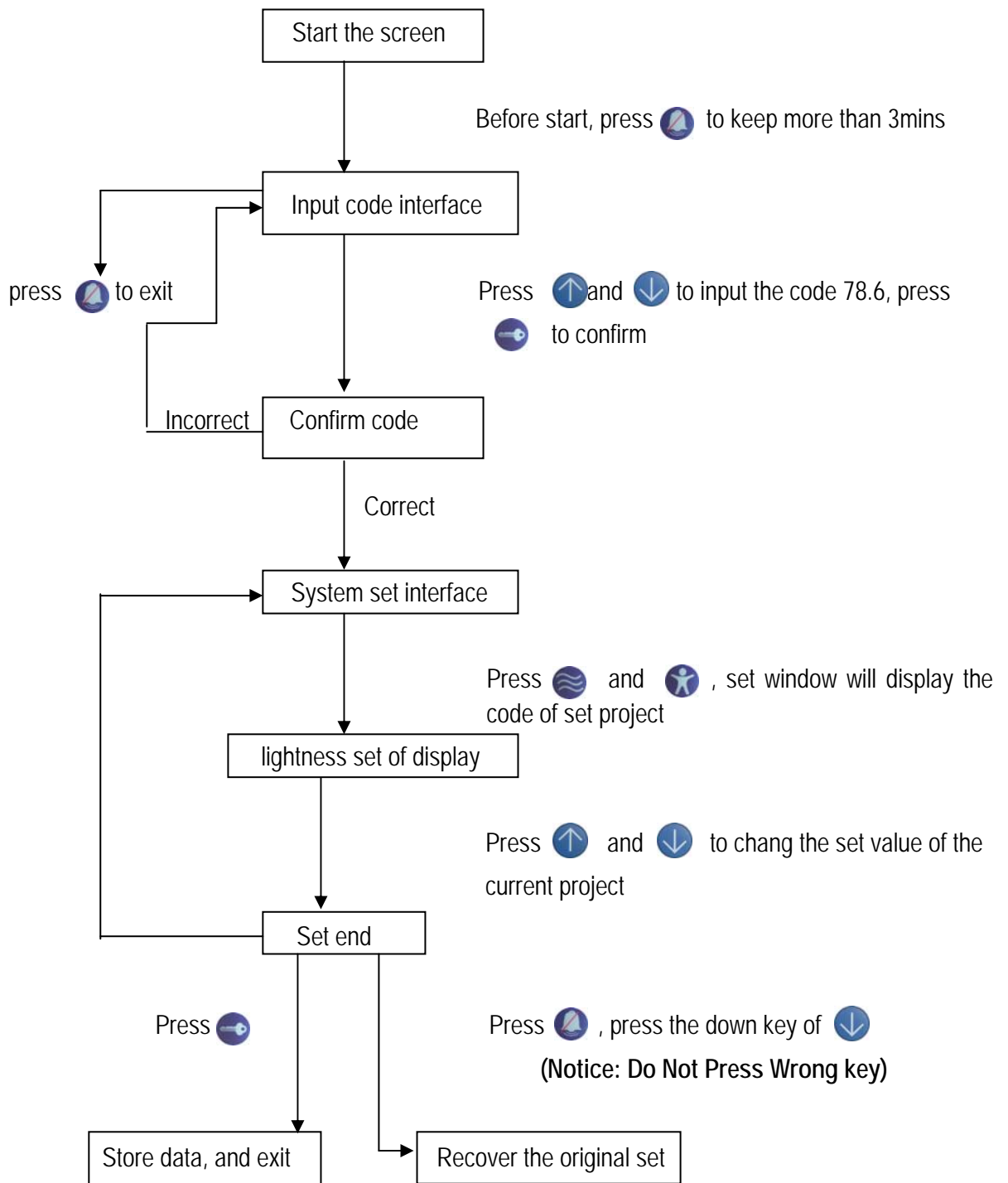
1. Brightness control of the display
2. Air temperature compensation
3. Skin-temp compensation
4. Air temperature upper deviation set
5. Air temperature lower deviation set
6. Skin-temp upper deviation set
7. Skin-temp lower deviation set
8. Fan block alarm set
9. Air temperature minimum set
10. Air temperature maximum set
11. Skin-temp minimum set
12. Skin-temp maximum set
13. Over-temp alarm set A
14. Over-temp alarm set B
15. Over-temp alarm set C



### 5.5.3 Procedure

First, plug the power, press the reset key continuously and turn on the power switch, after 3mins, the air-temp window will display --.--, other window had no indication. Press or until the real temperature window indicates 78.6, press , to enter into the system set interface. Or press to exit the procedure of system set.

After enter into the system set interface, temperature set window can display the code if some function, the real temperature window can display the specific data of the set of this function.



FLOW CHART 5.1 OPERATION FLOW CHART OF SYSTEM SET PROJECT

**CODE00.1 The lightness control of display**

Prescribe the lightness of display, set range 00.1~01.5, the larger the figure, the lighter the display.

**CODE 00.2 Air-temp compensation**

Prescribe the temperature compensation of the air temperature sensor, set range 00.0~ 05.0 and 10.0~15.0 , the first figure of the set value means the increasing or decreasing. For example, 00.2°C means the temperature measured by air-temp sensor adds 0.2°C as the compensation, 11.3°C means the temperature measured by air-temp sensor reduces 1.3°C as the compensation.

**CODE 00.3 Skin-temp compensation**

Prescribe the temperature compensation of the skin-temp, set range 0.0~05.0 and 10.0~15.0, the first figure of the set value means the increasing or decreasing. For example, 00.2°C means the temperature measured by air-temp sensor adds 0.2°C as the compensation, 11.3°C means the temperature measured by air-temp sensor reduces 1.3°C as the compensation.

**CODE 00.4 Air-temp upper deviation set**

Prescribe the method of setting for upper deviation of air-temp mode. For example 00.8 means 0.8°C.

**CODE 00.5 Air-temp lower deviation set**

Prescribe the method of setting for lower deviation of air-temp mode. For example 00.8 means 0.8°C.

**CODE 00.6 Skin-temp upper deviation set**

Prescribe the method of setting for upper deviation of skin-temp mode. For example 00.8 means 0.8°C.

**CODE 00.7 Skin-temp lower deviation set**

Prescribe the method of setting for lower deviation of skin-temp mode. For example 00.8 means 0.8°C.

**CODE 00.8 Fan block alarm set**

Prescribe the method of setting for fan block alarm set, this set value is 19.2. If the fan checking point is lower than this value, the system will alarm.

**CODE 00.9 Air-temp minimum set value**

Prescribe the method of air-temp set minimum value. For example 25.0 means the minimum value is 25.0°C.

**CODE 01.0 Air-temp maximum set value**

Prescribe the method of air-temp set maximum value in the mode of air-temp set value  $> 37^{\circ}\text{C}$ . For example 39.0 means the maximum value is 39.0°C.

### CODE 01.1 Skin-temp minimum set value

Prescribe the method of skin-temp set minimum value. For example, 34.0 means the maximum value is 34.0°C.

### CODE 01.2 Skin-temp maximum set value

Prescribe the method of skin-temp maximum value in the mode of skin-temp set value  $> 37^{\circ}\text{C}$ . For example 38.0 means the maximum value is 38.0°C.

### CODE 01.3 Over-temp alarm set A

Prescribe the method of air-temp set value in the mode of air-temp set value  $< 37.0^{\circ}\text{C}$ . For example 37.8 means the over-temp is 37.8°C.

### CODE 01.4 Over-temp alarm set B

Prescribe the method of air-temp set value in the mode of air-temp set value  $< 37.0^{\circ}\text{C}$ . For example 39.5 means the over-temp is 39.5°C.

### CODE 01.5 Over-temp alarm set C

Prescribe the method of over-temp set value in the mode of skin-temp. For example 39.8 means the over-temp is 39.8°C.

## 5.6 PROCEDURE OF TROUBLE-SHOOTING

### 5.6.1 Introduction

Section 5.6.4 and 5.6.5 will offer the repairing methods of temperature control. In section 5.6.4, it offers the alarm code when the alarm of the temperature control happens; In section 5.6.5, it gives the details of the repairing methods by the way of flow chart.

**NOTE: Before deal with the troubles, you should confirm the correct set of the system set procedure.**

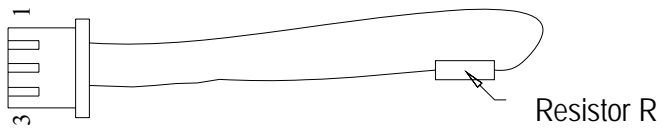
### 5.6.2 Test device

During the trouble-shooting procedure, it needs the following test devices, and you can replace it with the same effect device.

- Figure clock, FLUKE 17B Type
- 31.0°C skin temperature simulation
- 37.0°C air temperature simulation

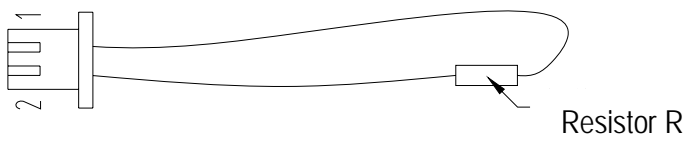
### 5.6.3 Temperature simulation device

- 31.0°C skin temperature simulation



Resistor R=23166Ω/0.25W/0.5%

- 37.0°C air temperature simulation



Resistor R=18030Ω/0.25W/0.5%

- 37.0°C Isolated temperature simulation  
37.0°C air temperature simulation

### 5.6.4 Alarm code

Other alarm have the relative alarm code except for the power failure alarm, see table 5.1

**TABLE 5.1 CLASSIFICATION OF ALARM CODE**

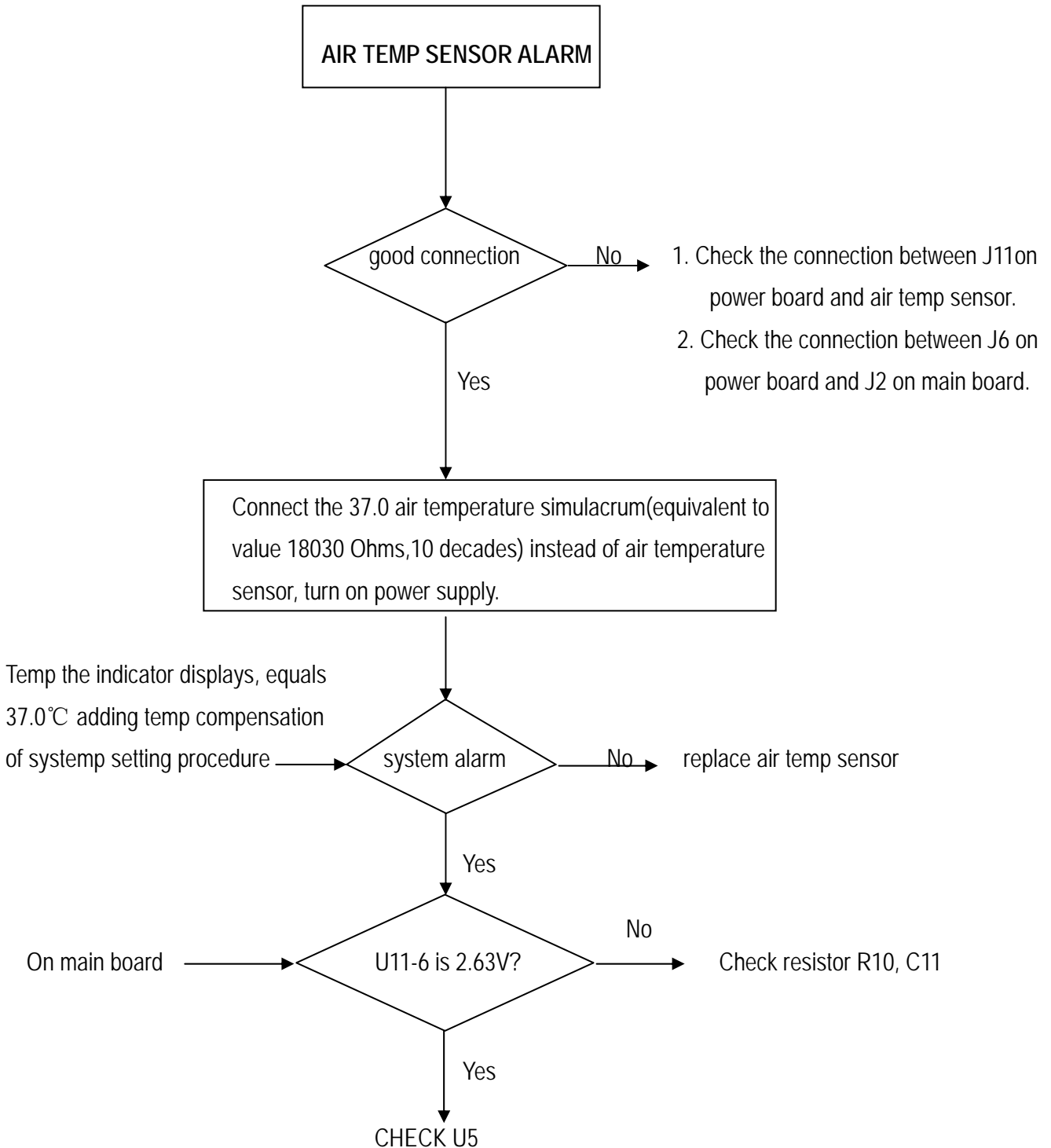
Alarm code	Classification	Cause and method
E0.1	Air temperature sensor failure alarm	See flow chart 5.2
E0.2	Isolated temperature sensor alarm	See flow chart 5.3
E0.3	Air temperature deviation failure alarm	See flow chart 5.4
E0.4	Skin temperature sensor failure alarm	See flow chart 5.5
E0.5	Over temperature failure alarm	Refer to Flow chart 5.6
E0.6	Fan motor stop alarm	Check the connecting wire of the fan
E0.7	Fan motor retard alarm	Check whether the fan stops working or the low speed
E0.8	Wrong position of skin sensor alarm	Check the position of skin sensor
E0.9	High deviation temperature failure alarm	1. Check whether there is heat source nearby, if yes, please leave far away from the heat source. 2. Check the close condition of all doors and panels
E1.0	Low deviation temperature failure alarm	The same as high deviation alarm
E1.1	Low voltage alarm	See flow chart 5.7
	Power failure alarm	See flow chart 5.8
H0.1	ROM failure alarm inside auxiliary MCU	Replace the main MCU U10.
H0.2	Internal system failure alarm inside main MCU	Replace the main MCU U10.
H0.3	Communication Failure	1. Check the connection of circuit between the main MUC and auxiliary MCU 2. Replace main MUC and auxiliary MCU

TABLE 5.1 CLASSIFICATION OF ALARM CODE (CONTINUE)

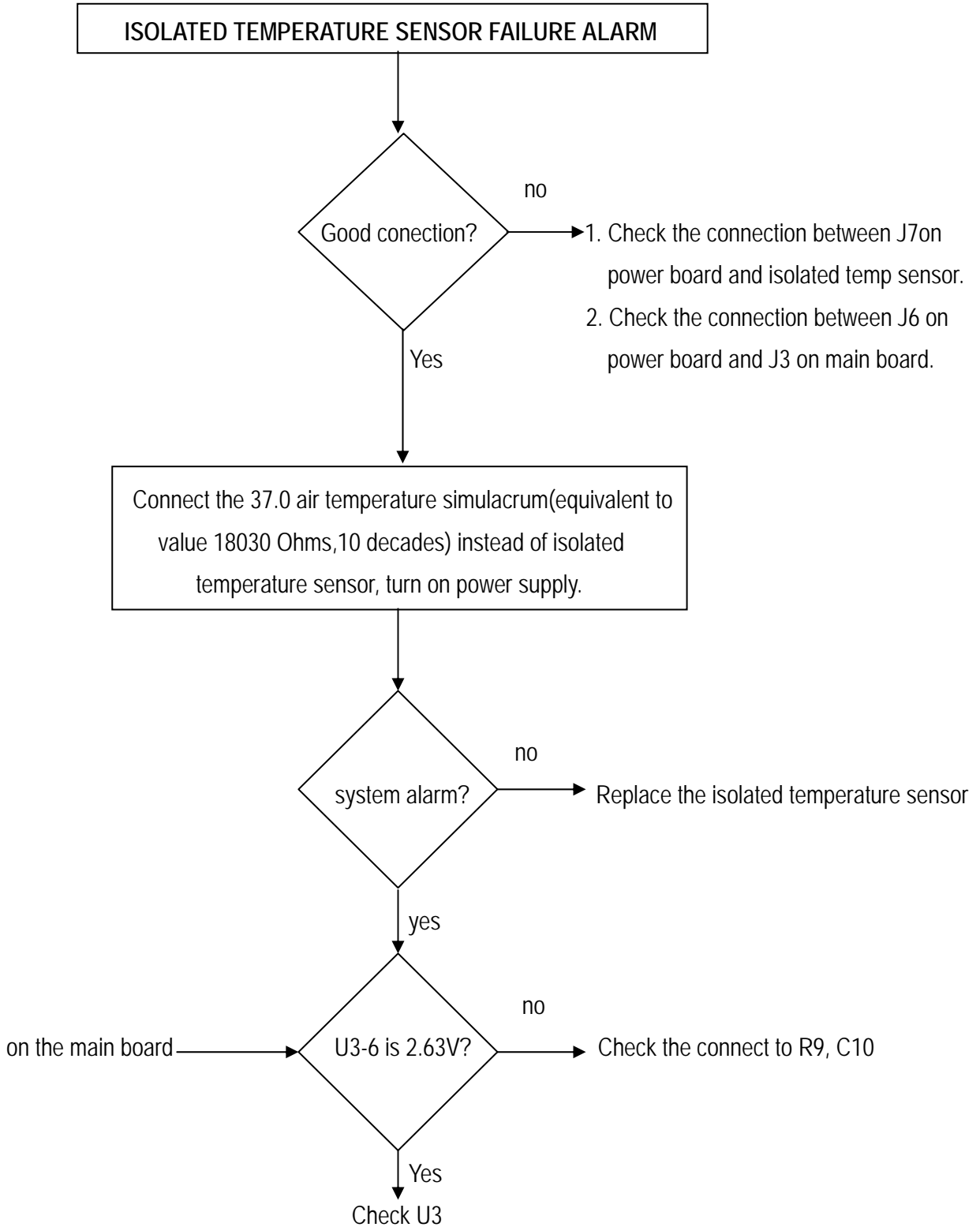
Alarm code	Classification	Cause and method
H0.4	ROM malfunction alarm inside of auxiliary MCU	Replace the auxiliary MCU U13
H0.5	Internal system failure alarm inside auxiliary MCU	Replace the auxiliary MCU U13
H0.6	E <sup>2</sup> PROM failure alarm	Replace Main MCU U10
H0.7	Main ADC failure alarm	Check U5, ADC and other connecting wire.
H0.8	Auxiliary ADC failure alarm	Check U3, ADC and other connecting wire.
H0.9	Heating control relay malfunction alarm	<ol style="list-style-type: none"> <li>1. Check the heating control relay K3 on the power board, triode Q2 and other controlling circuit.</li> <li>2. Check the MOS Q4, Q5 on the power board to see whether they're damaged or not.</li> <li>3. Check the electronic parts U5 and its relative circuit.</li> <li>4. Check the heater to see whether it's broken or bad connected.</li> </ol>
H1.0	Power voltage overlarge failure	See flow chart 5.9
H1.1	Keyboard fault alarm	Replace the control panel
H1.2	Battery failure alarm	Replace the inner storage battery
H1.3	Connecting parts between the storage battery and the power box fault alarm	Check the connecting socket between the battery and the power box, and check the connection of the socket J9 in the power board.

5.6.5 Check flow chart

Before checking, first, open the cover of the power supply box, at the same time, keep the power +5V and +12V of temperature control normal, device and lead's connection normal. In the state of working, press upper key and Air-temp key, the air-temp window, skin-temp window and storage battery capacity window will display isolated over-temp sensor temperature, DC power voltage, storage battery voltage respectively, and then press skin-temp key, the skin-temp window will show the output voltage of power switch so as to be easy to find the reason of faults for repairman.

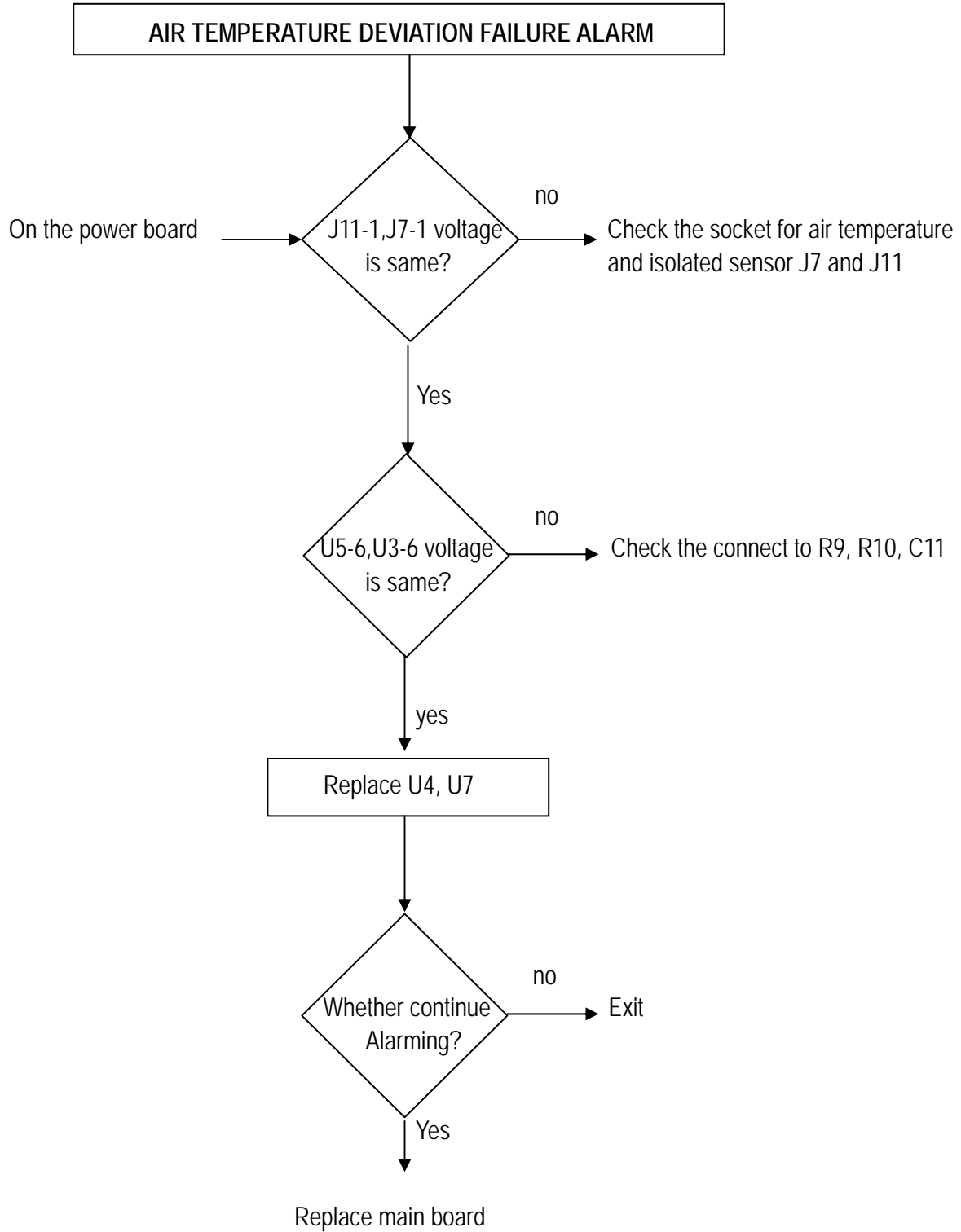


FLOW CHART 5.2 AIR TEMPERATURE SENSOR ALARM

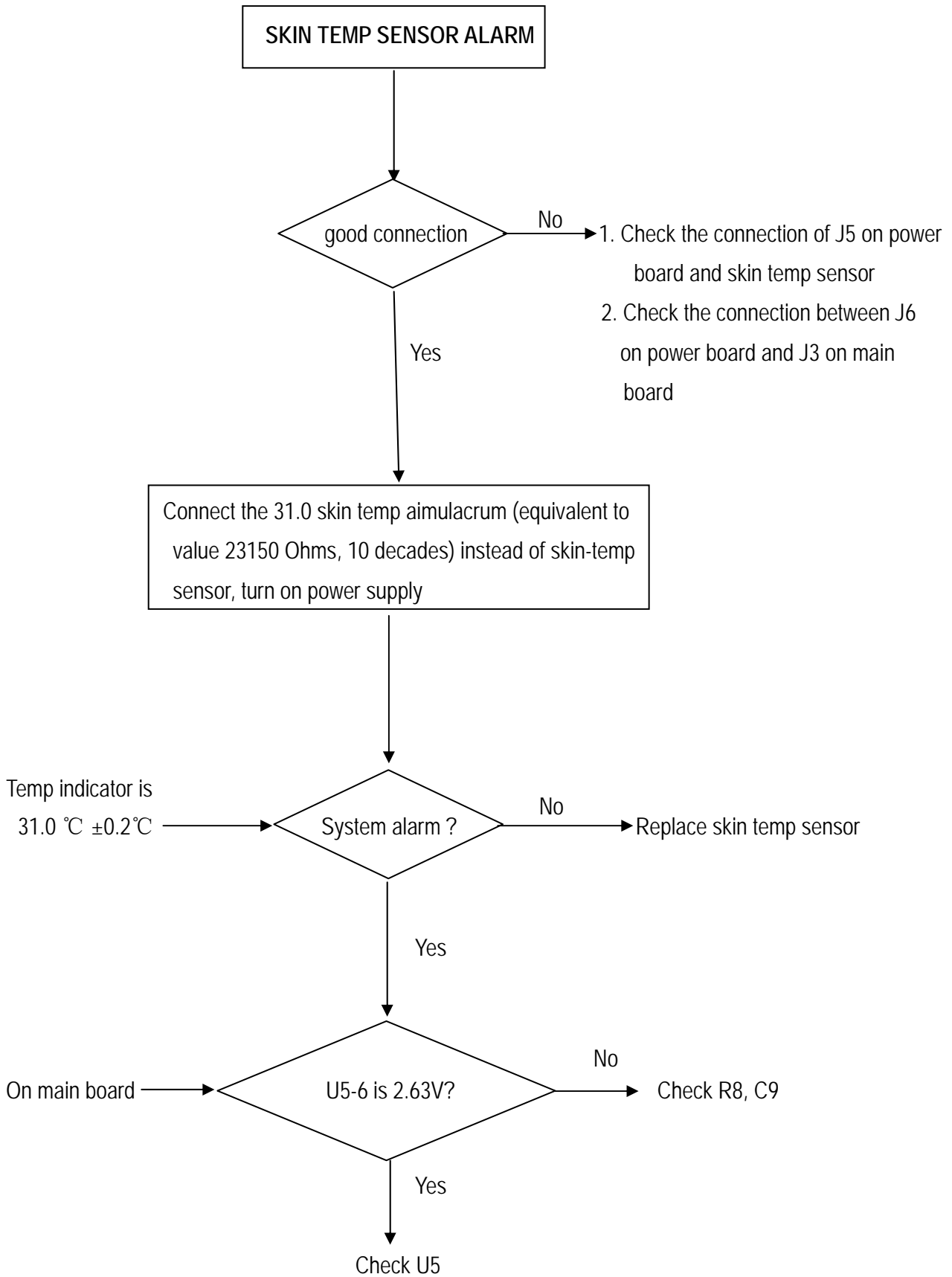


FLOW CHART 5.3 ISOLATED TEMPERATURE SENSOR ALARM

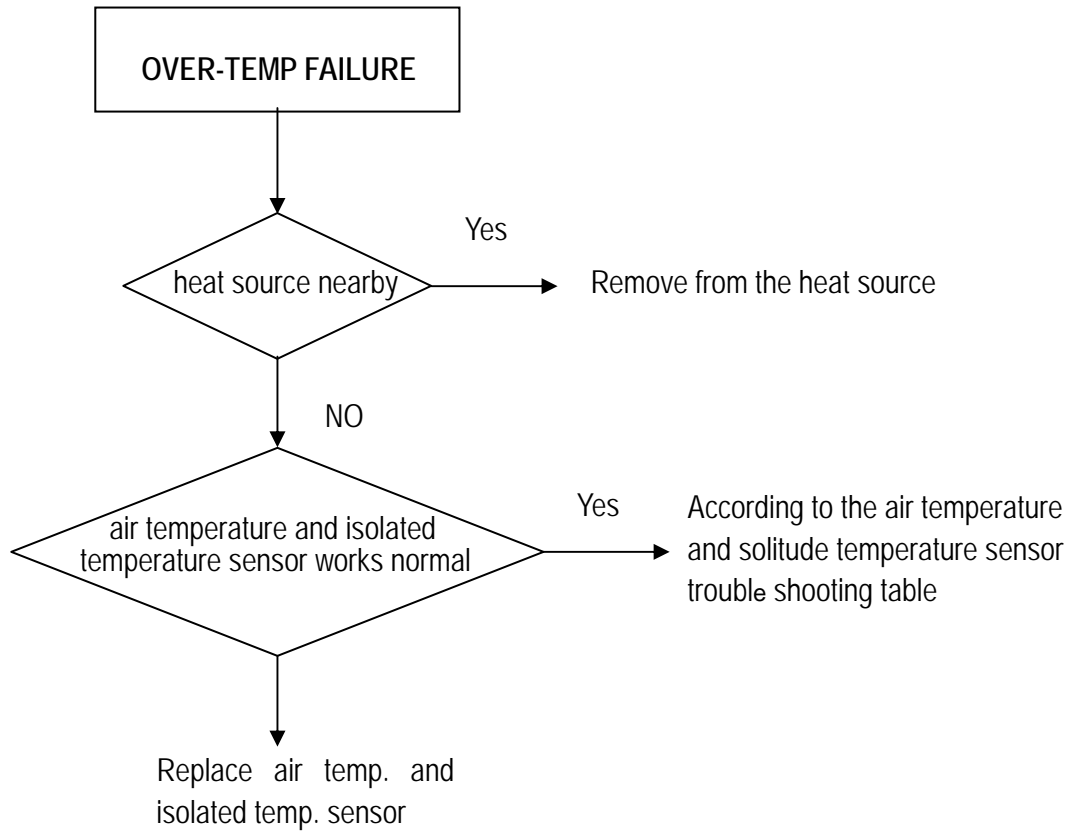




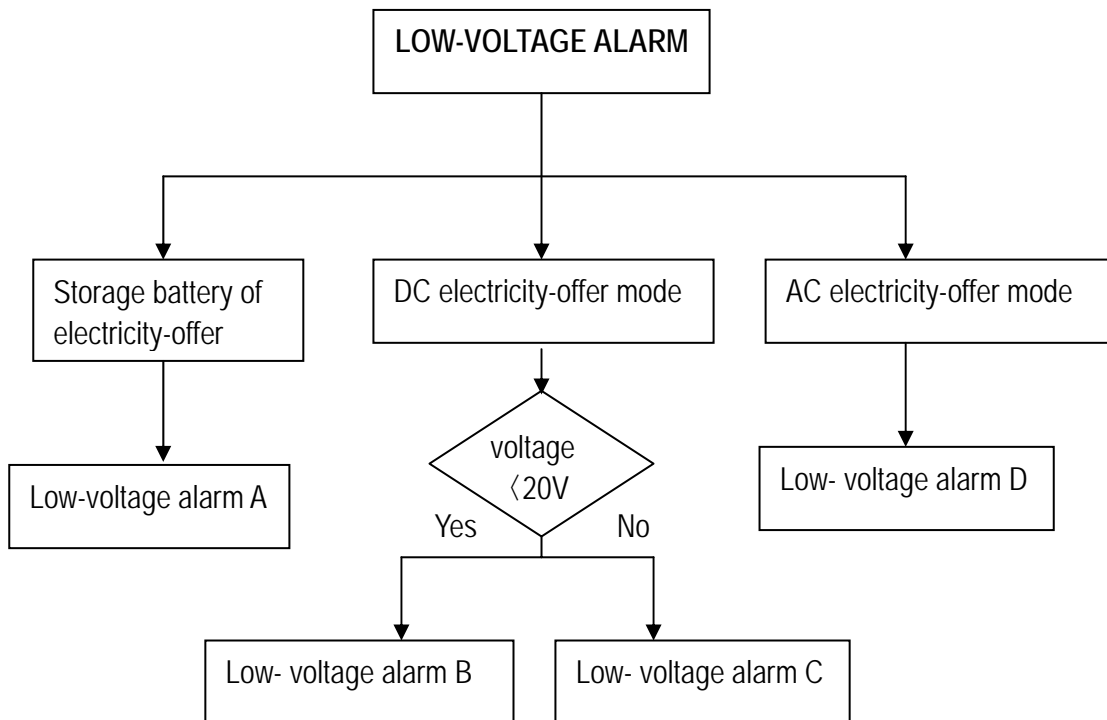
FLOW CHART 5.4 AIR TEMPERATURE DEVIATION FAILURE ALARM



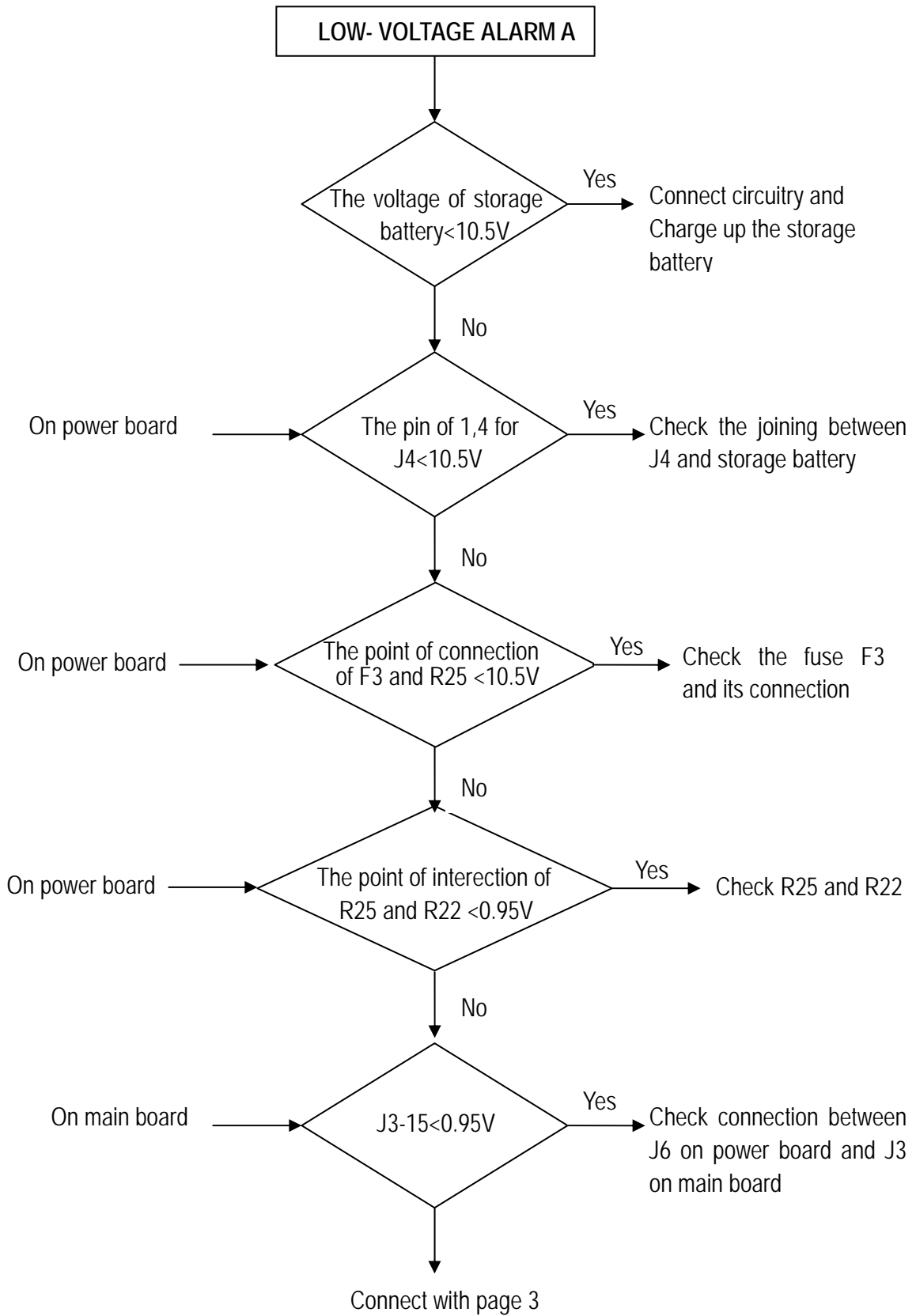
FLOW CHART 5.5 SKIN TEMPERATURE SENSOR ALARM



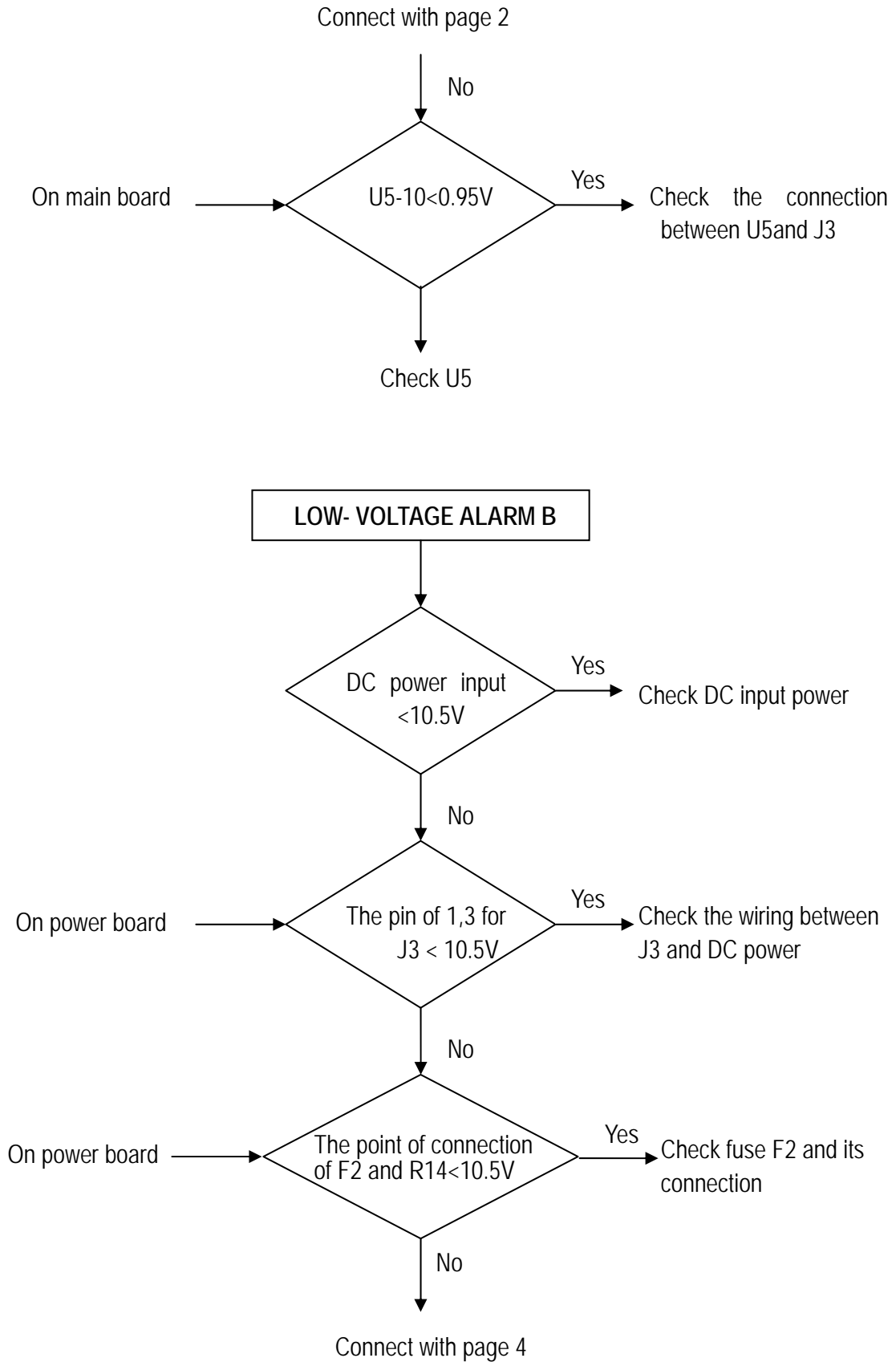
FLOW CHART 5.6 OVER-TEMP FAILURE



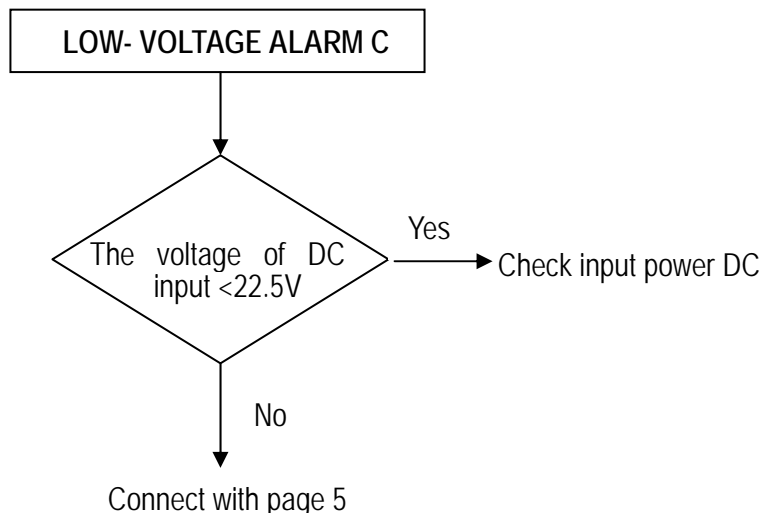
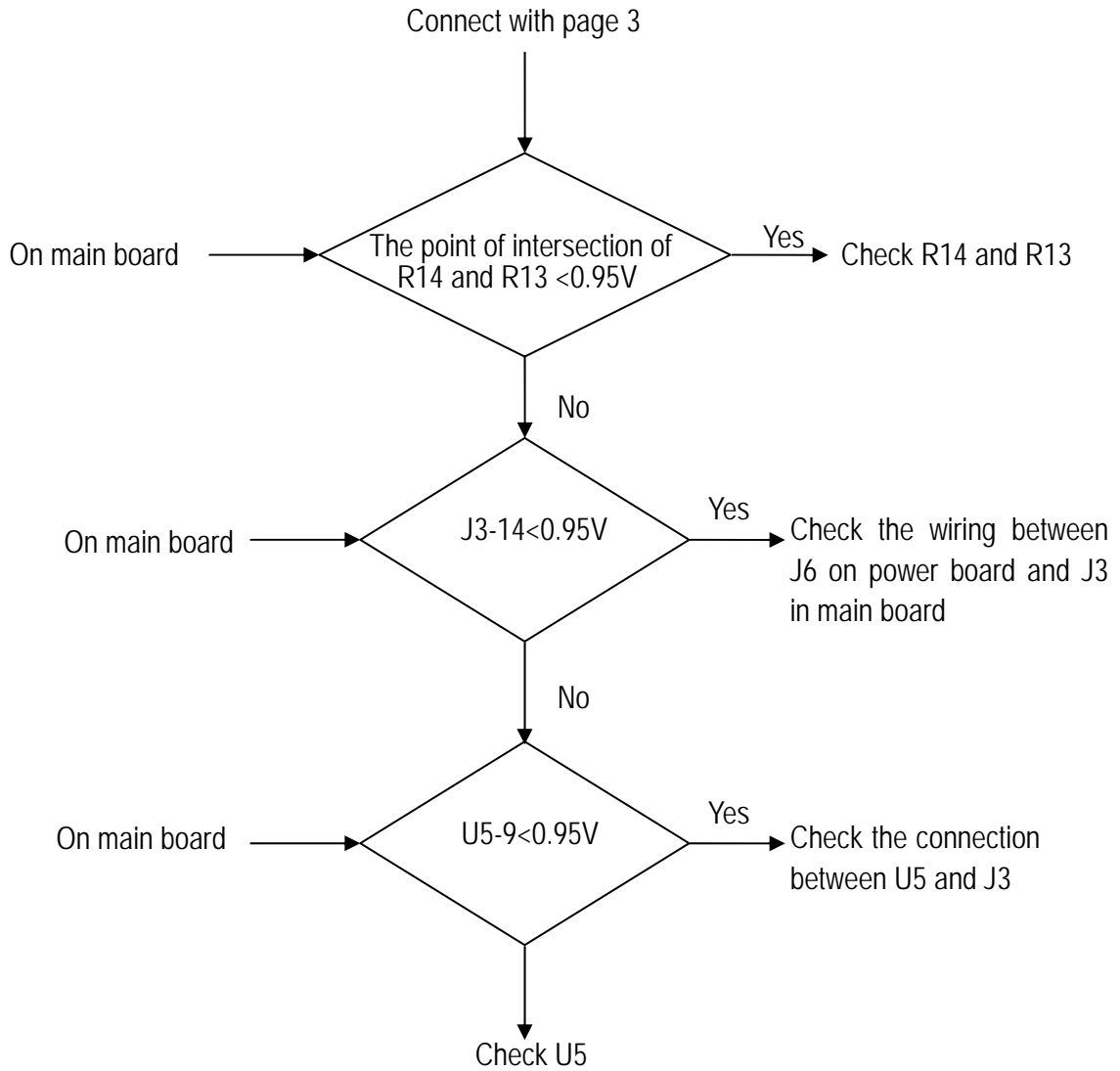
FLOW CHART 5.7 LOW-VOLTAGE ALARM (SHEET 1 OF 7)



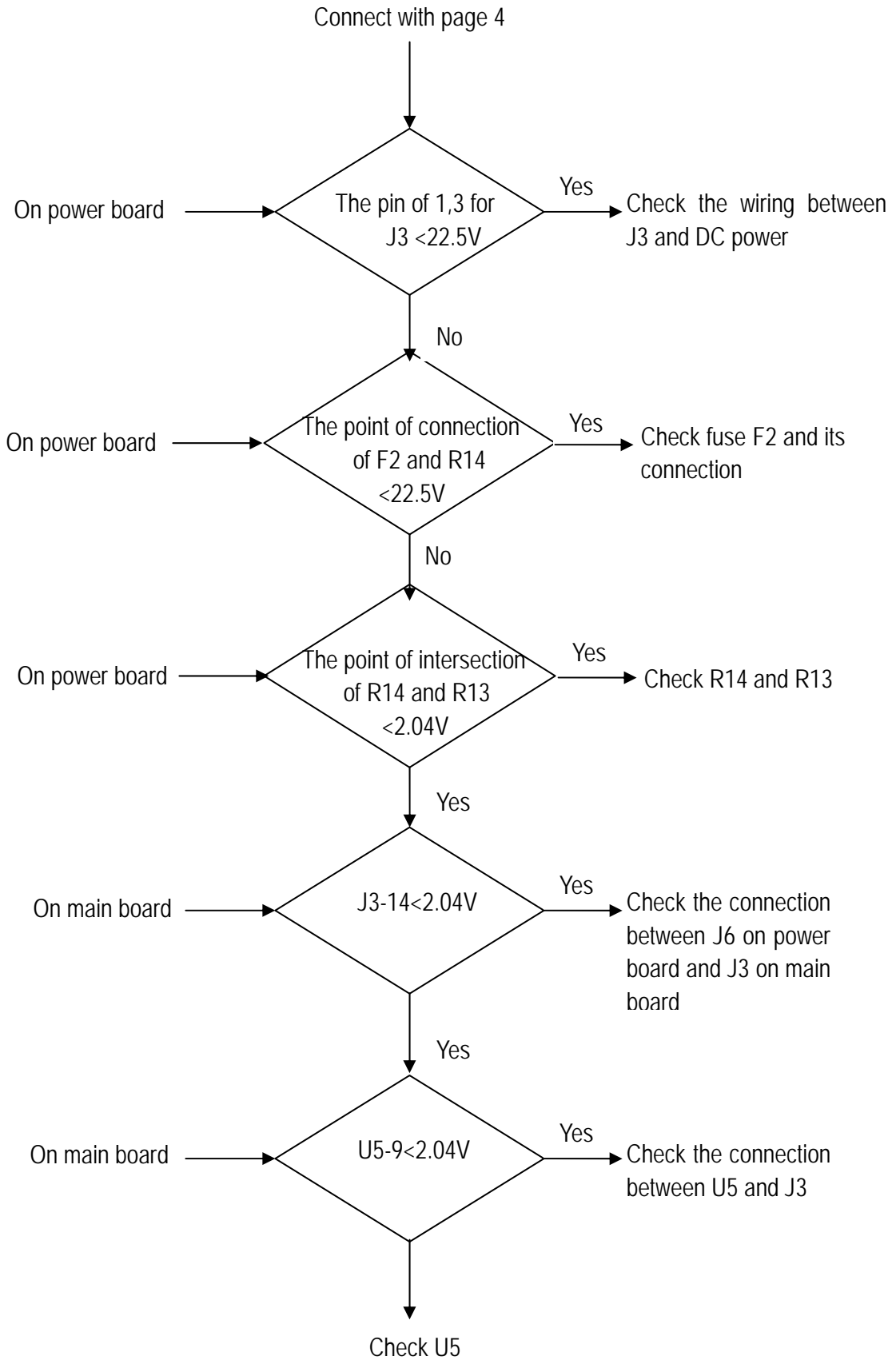
FLOW CHART 5.7 LOW-VOLTAGE ALARM (SHEET 2 OF 7)



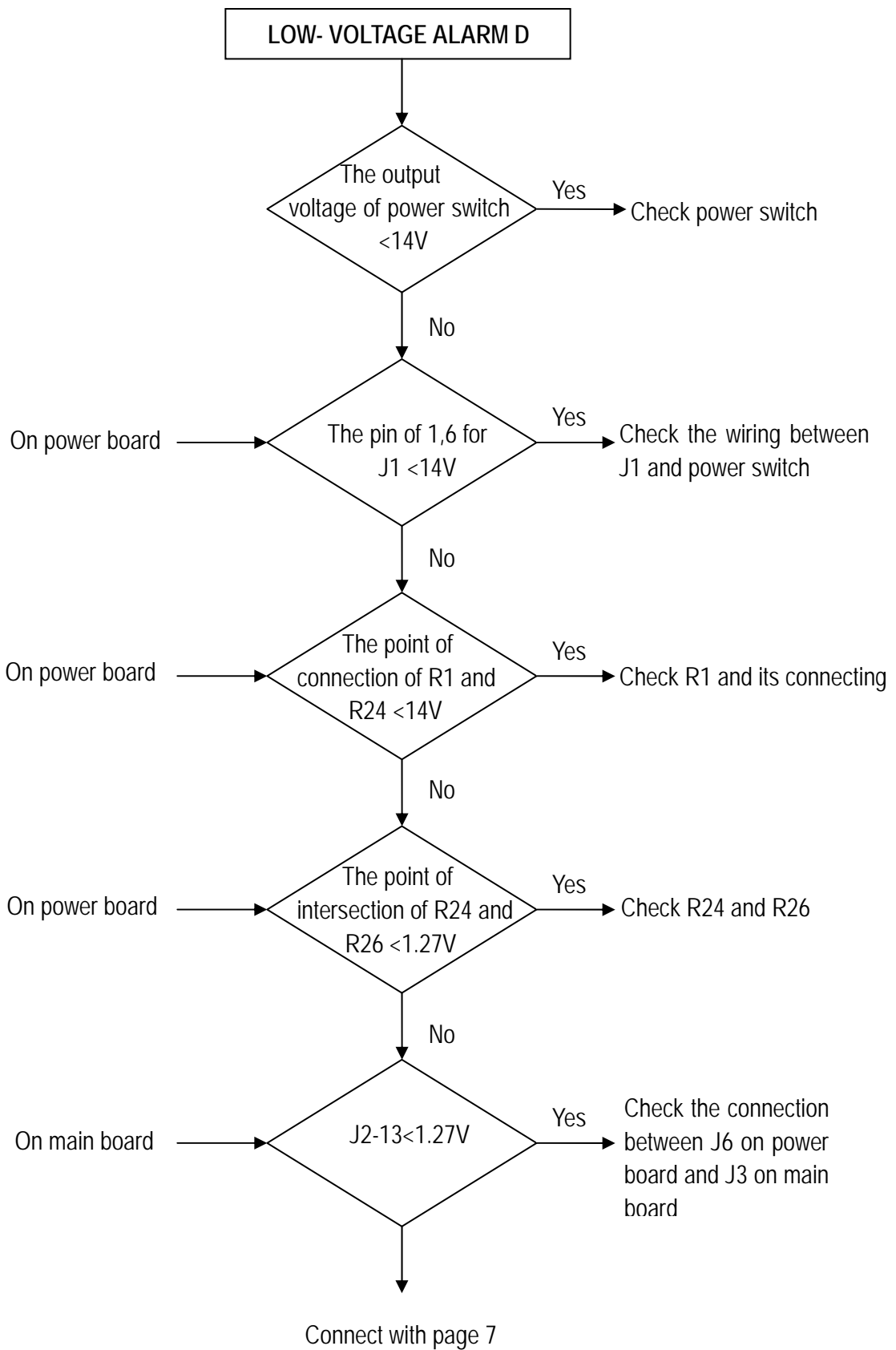
FLOW CHART 5.7 LOW-VOLTAGE ALARM (SHEET 3 OF 7)



FLOW CHART 5.7 LOW-VOLTAGE ALARM (SHEET 4 OF 7)

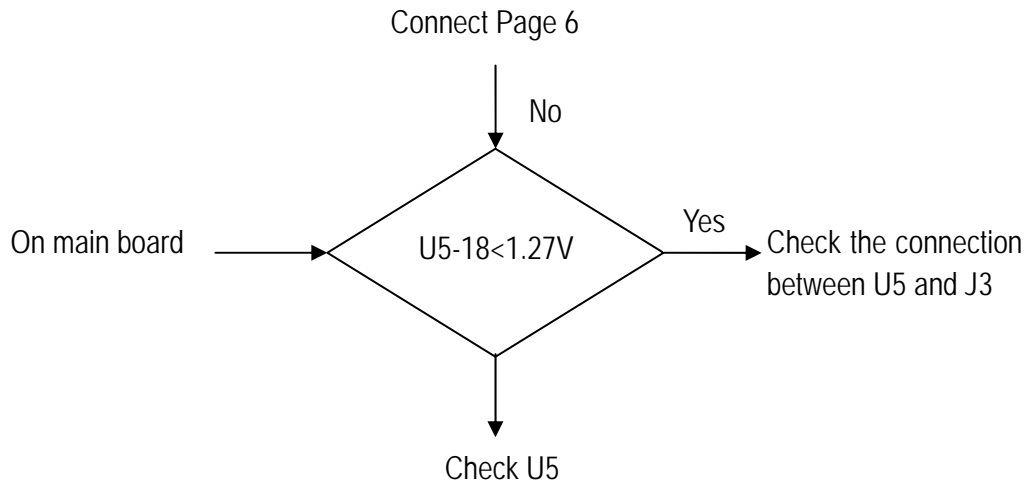


FLOW CHART 5.7 LOW-VOLTAGE ALARM (SHEET 5 OF 7)

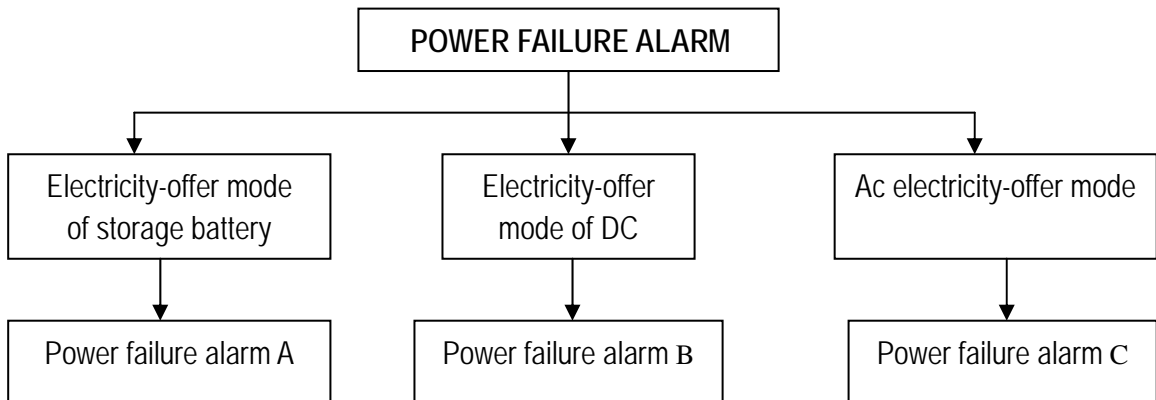


FLOW CHART 5.7 LOW-VOLTAGE ALARM (SHEET 6 OF 7)

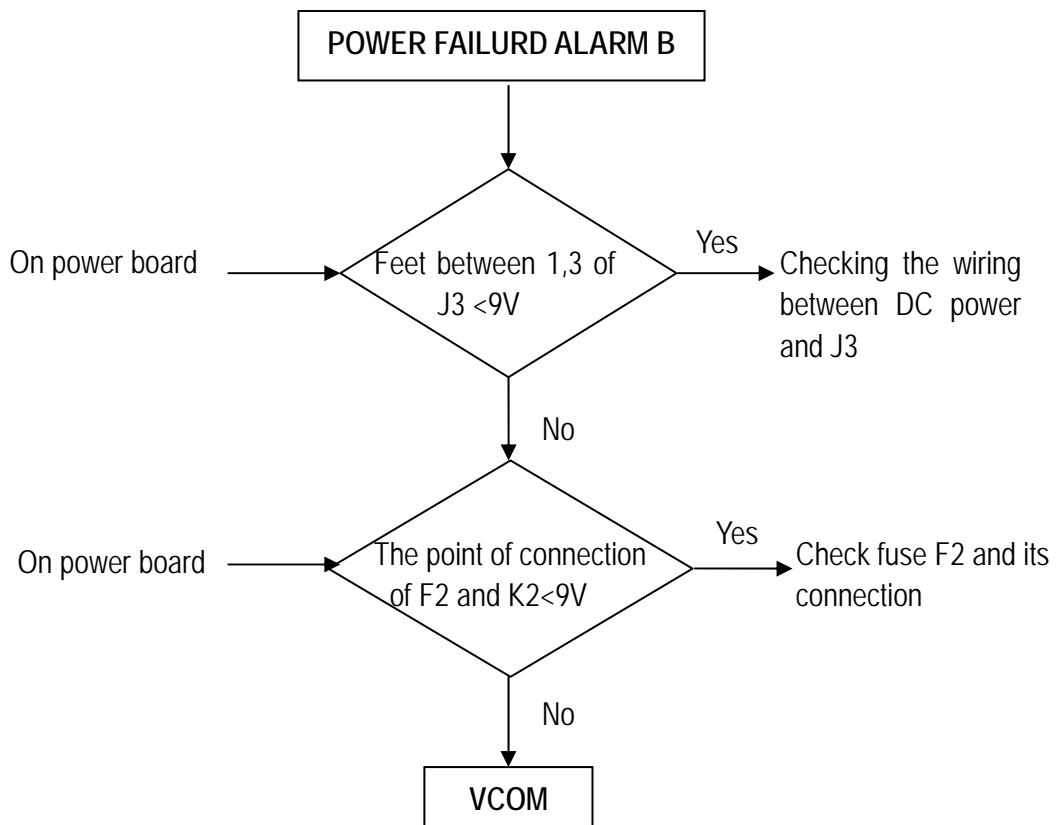
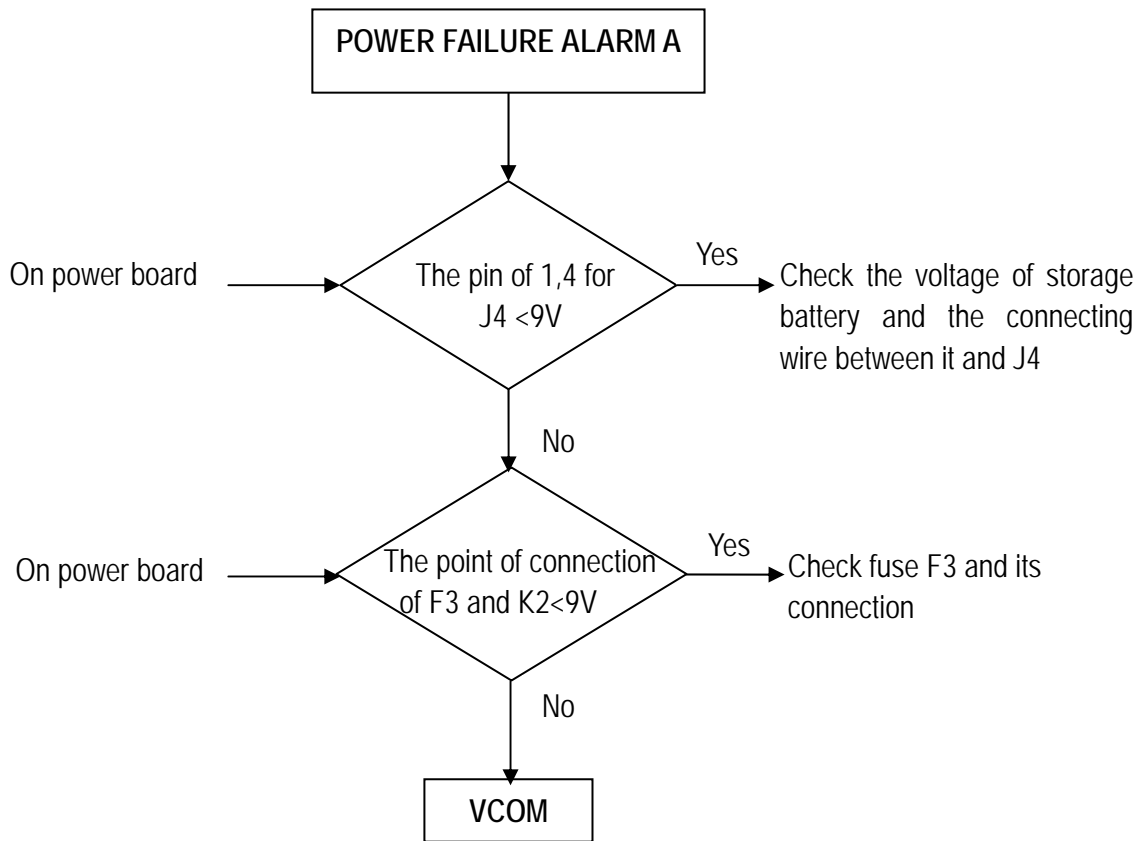




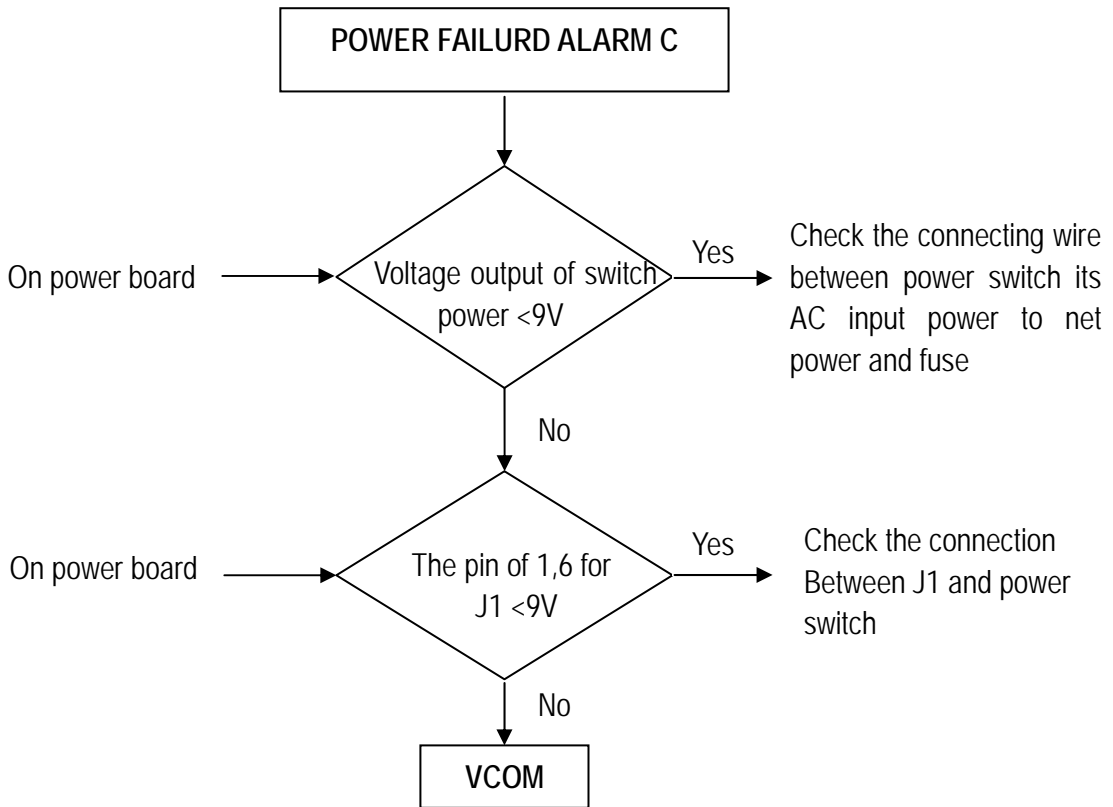
FLOW CHART 5.7 LOW-VOLTAGE ALARM (SHEET 7 OF 7)



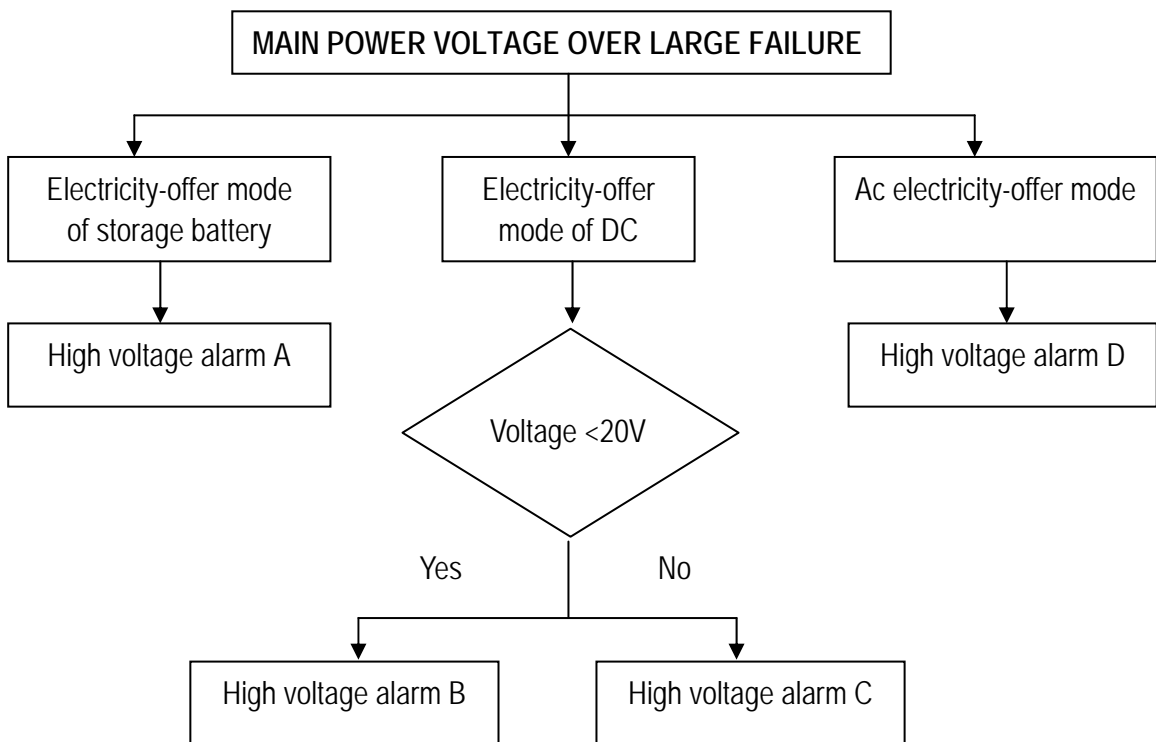
FLOW CHART 5.8 POWER FAILURE ALARM (SHEET 1 OF 3)



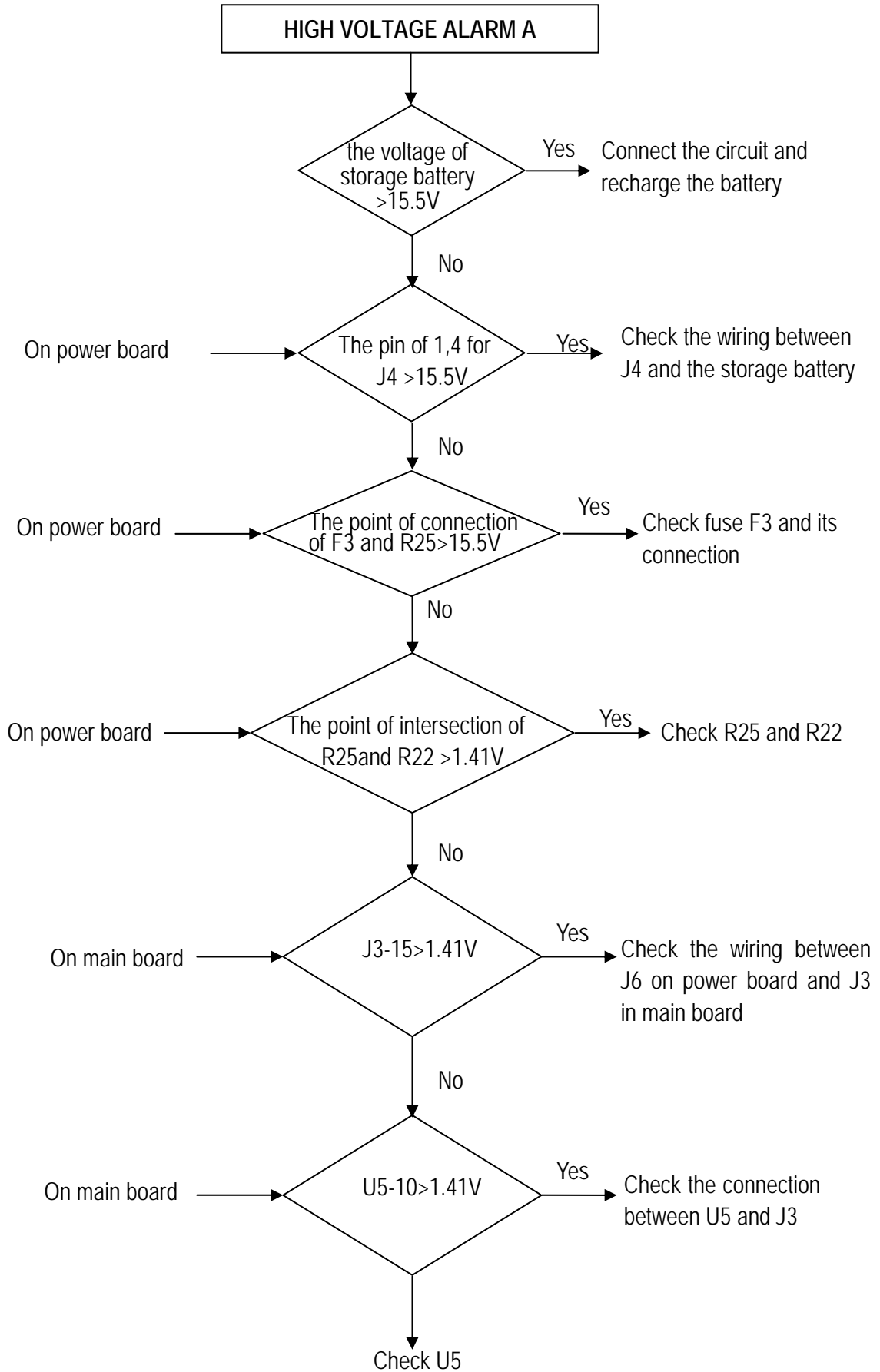
FLOW CHART 5.8 POWER FAILURE ALARM (SHEET 2 OF 3)



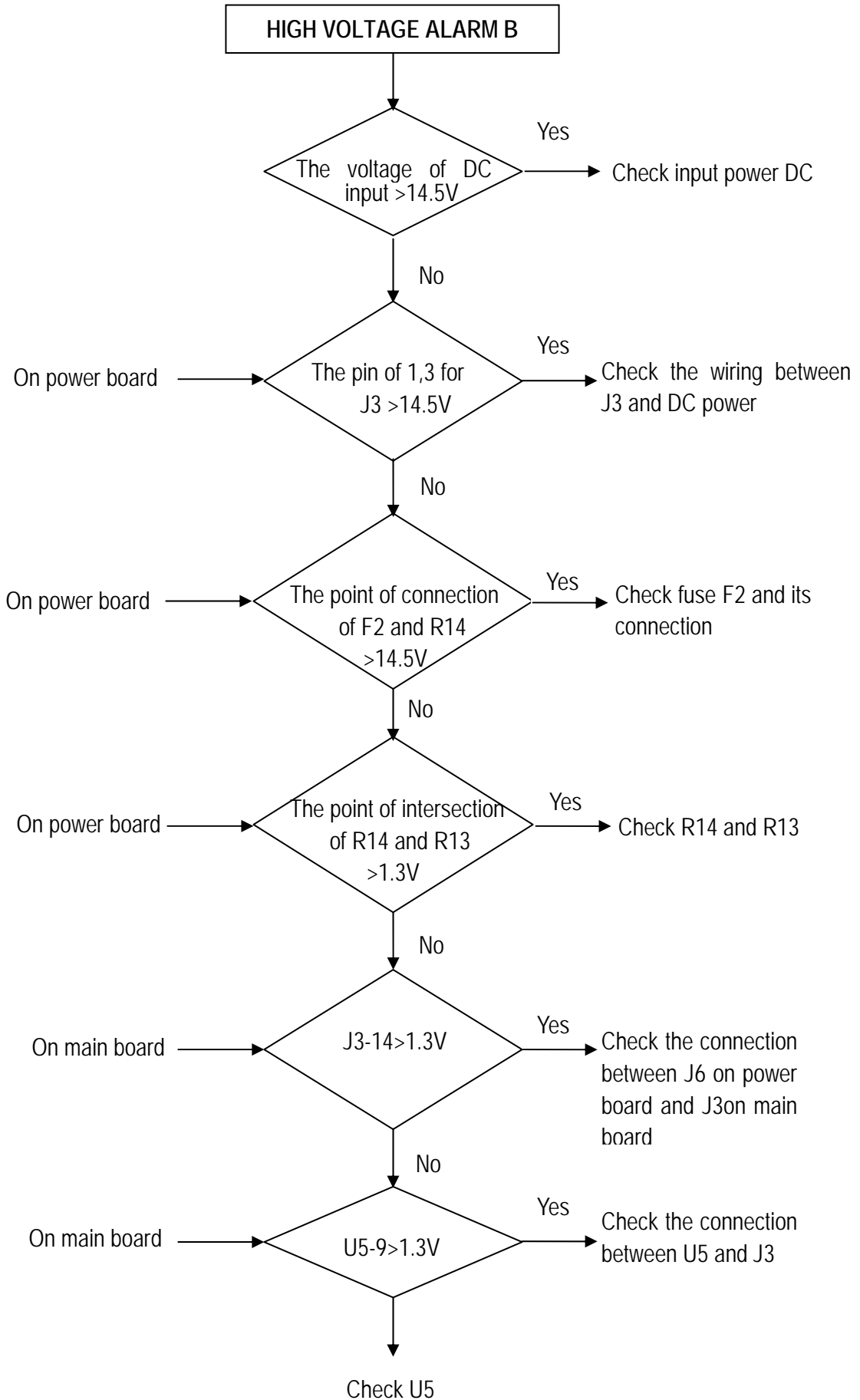
FLOW CHART 5.8 POWER FAILURE ALARM (SHEET 3 OF 3)



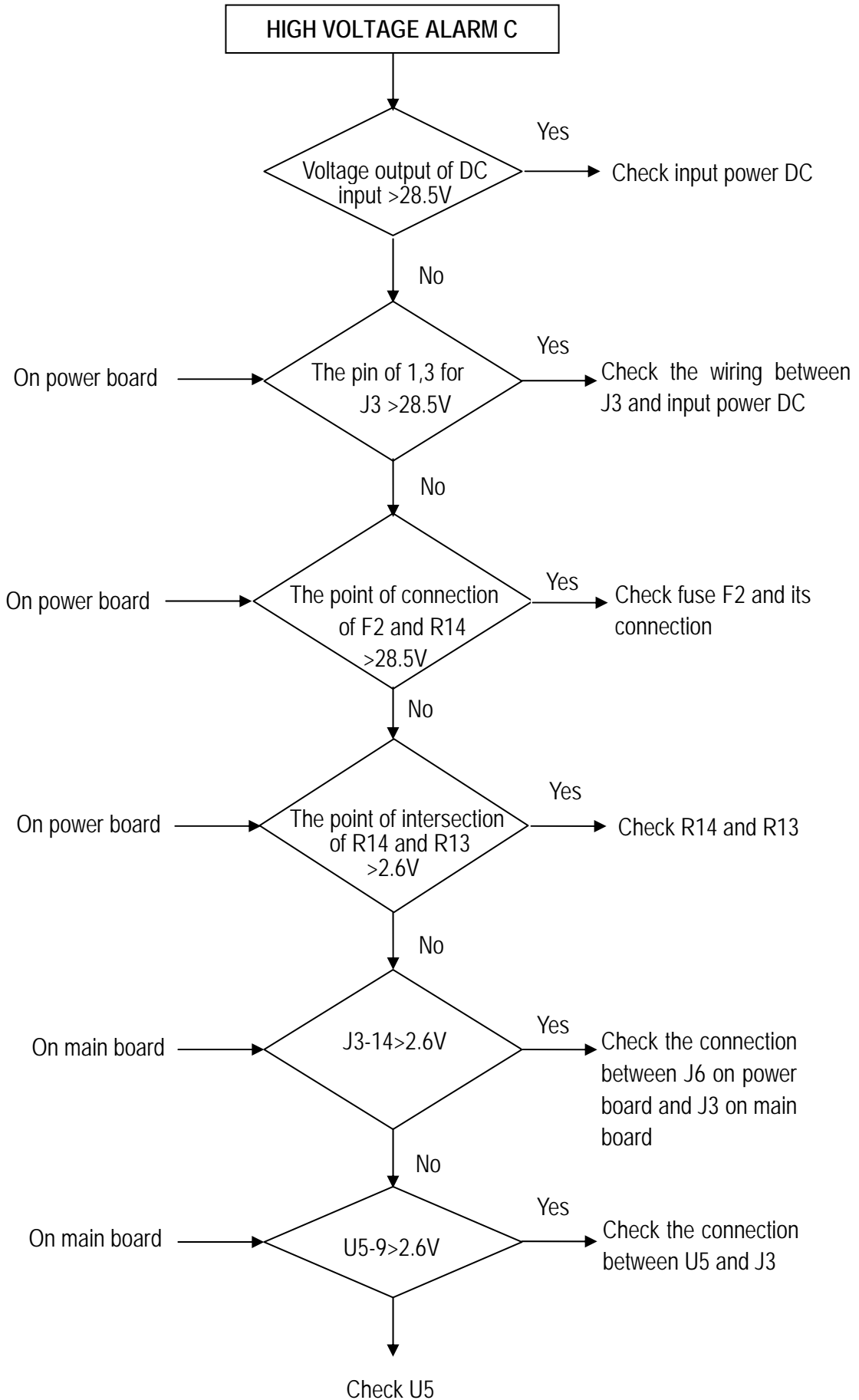
FLOW CHART 5.9 MAIN POWER VOLTAGE OVER LARGE FAILURE (SHEET 1 OF 4)



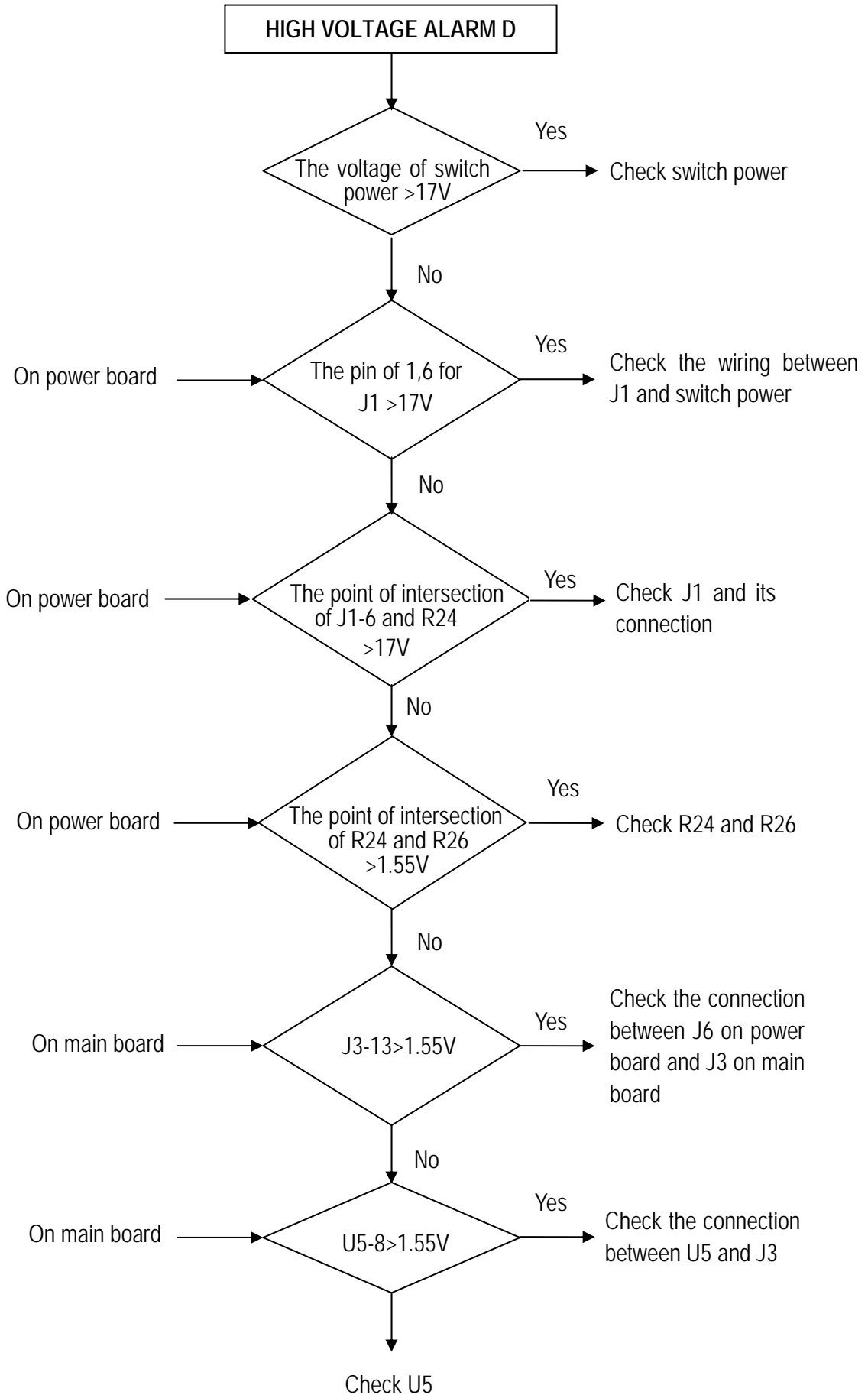
FLOW CHART 5.9 MAIN POWER VOLTAGE OVER LARGE FAILURE (SHEET 2 OF 4)



FLOW CHART 5.9 MAIN POWER VOLTAGE OVER LARGE FAILURE (SHEET 3 OF 4)



FLOW CHART 5.9 MAIN POWER VOLTAGE OVER LARGE FAILURE (SHEET 4 OF 4)



FLOW CHART 5.9 MAIN POWER VOLTAGE OVER LARGE FAILURE (SHEET 4 OF 4)

## SECTION 6 REPLACEMENT PARTS

### 6.1 GENERAL

This section provides parts lists for infant incubator. Part numbers of accessories are provided below:

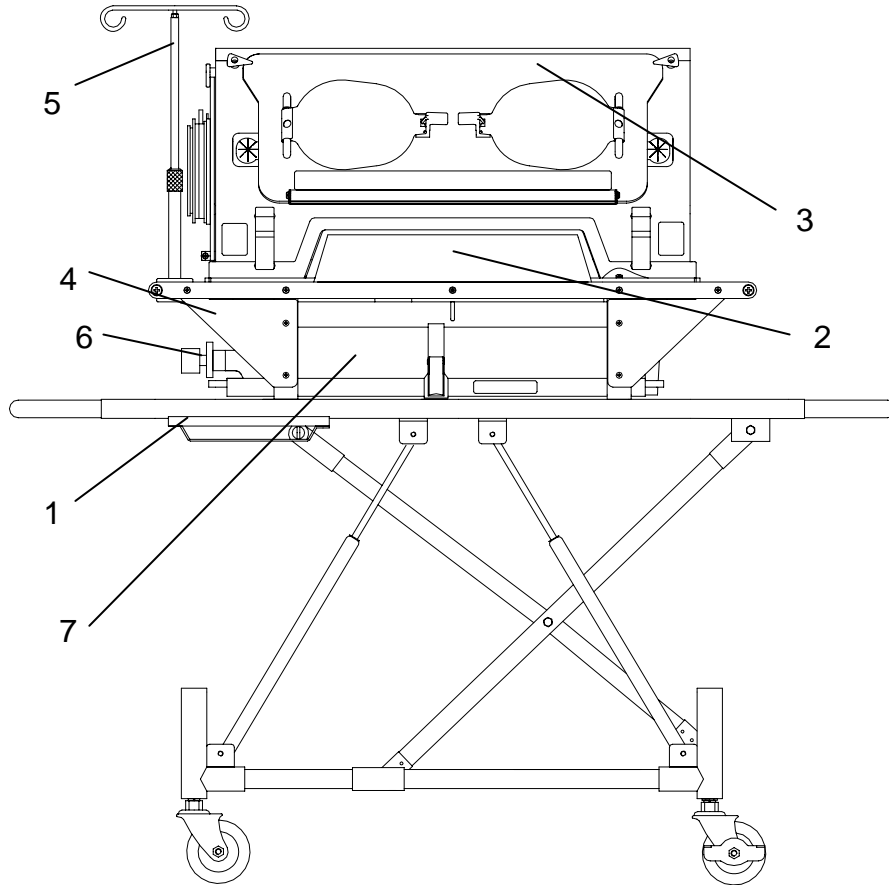
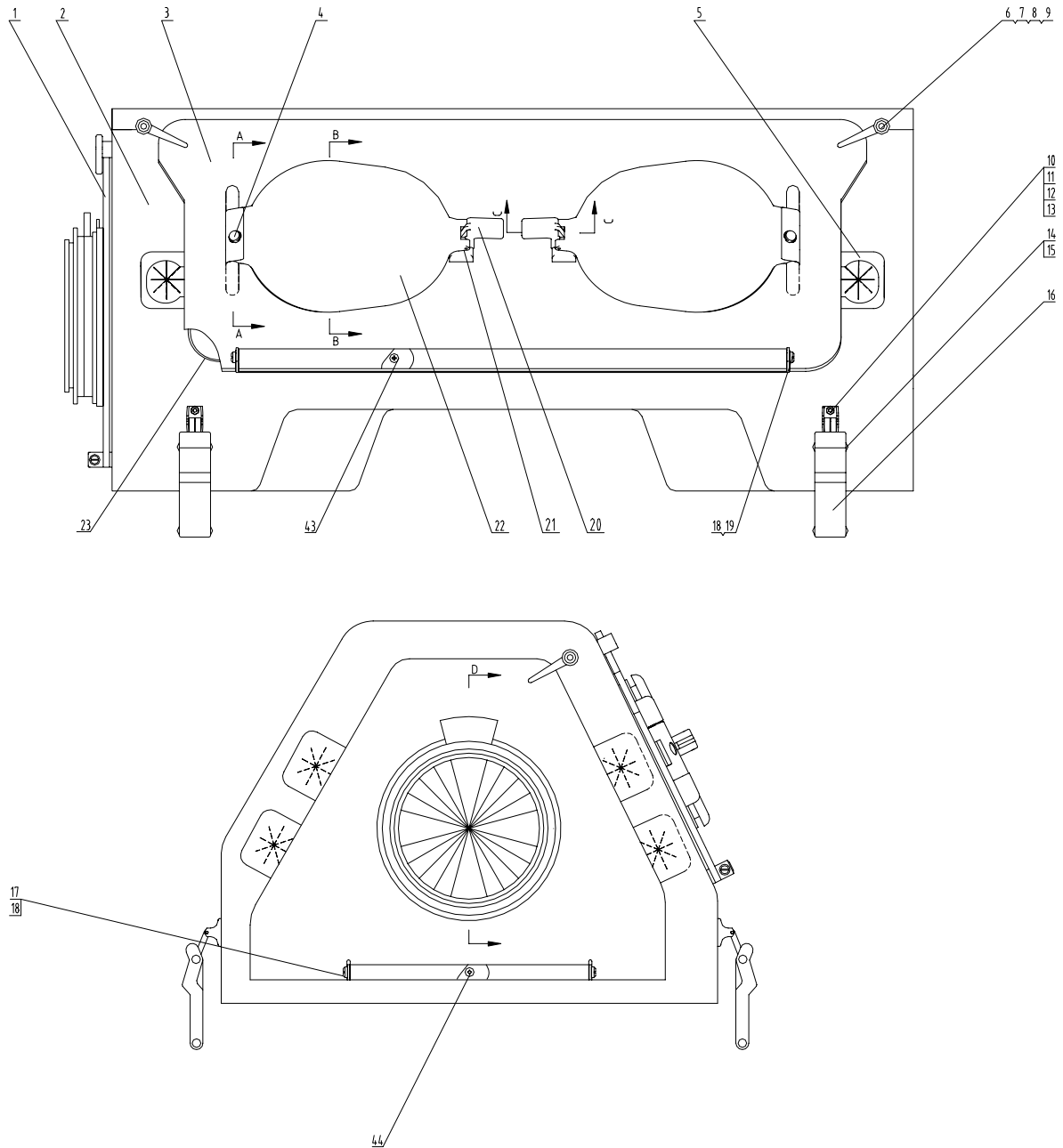


Figure 6.1 Parts Location Diagram, whole unit

Table 6.1 Parts and Accessories List, whole unit

ITEM No.	DESCRIPTION	PART NUMBER
1	Trolley	T01 001 00
2	Controller	T02 000 00
3	Hood	T03 000 00
4	Base	T04 000 00
5	I. V. Pole Groupware	T05 000 00
6	Oxygen feeding valve	T04 005 00
7	Oxygen cylinder	T04 004 00

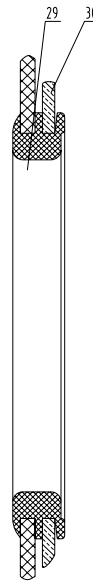
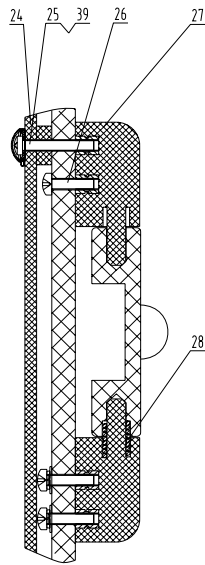




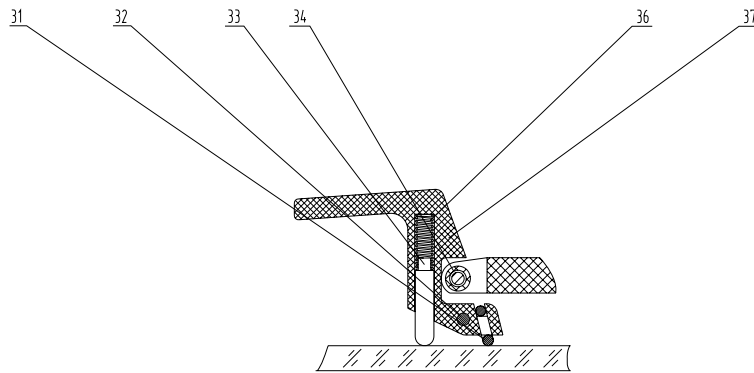
FLOW CHART 6.2 Replacing parts for hood (Sheet 1 of 2)

A-A Circumgyrate 26°

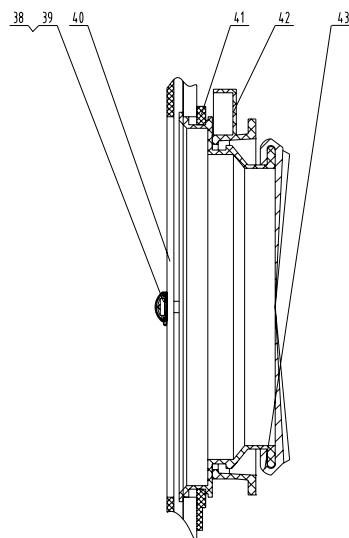
B-B Circumgyrate 26°



C-C



D-D



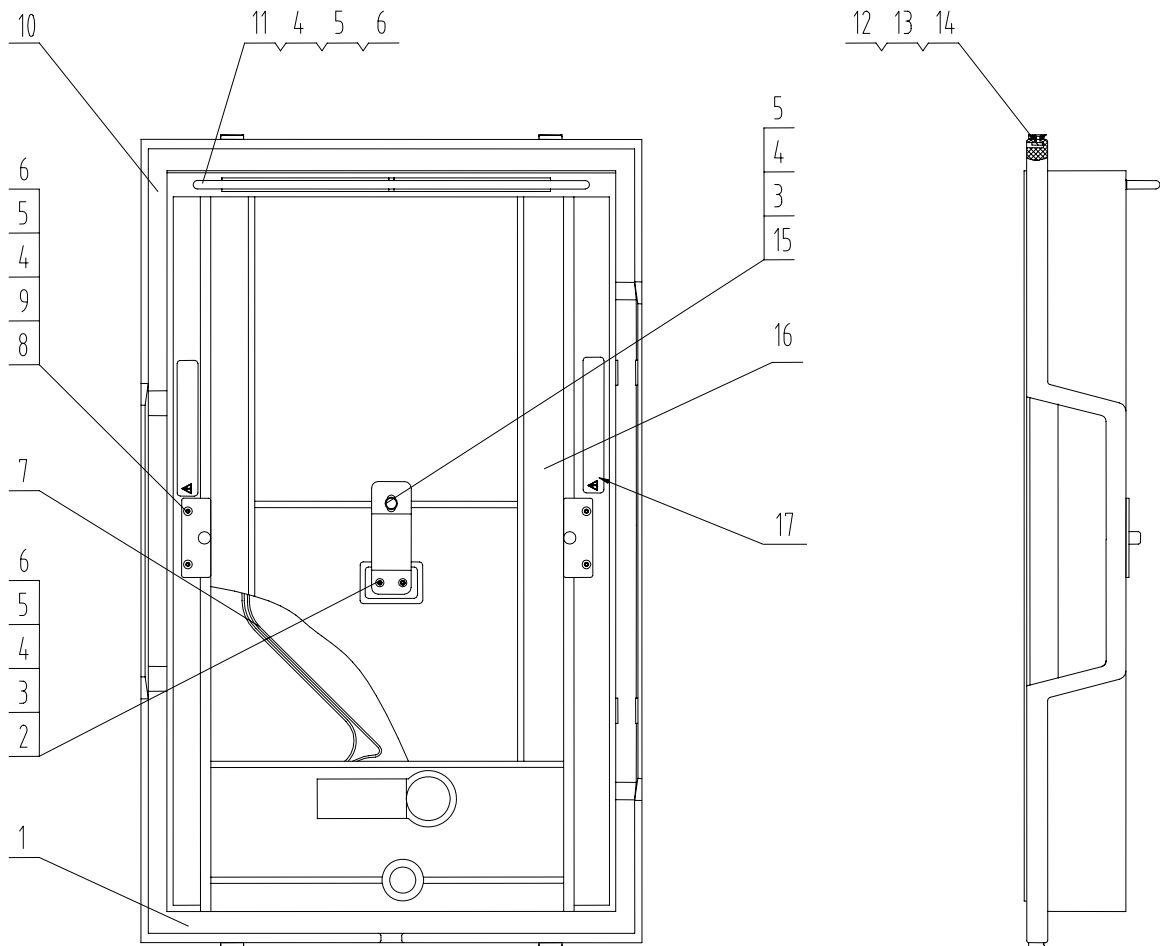
FLOW CHART 6.2 Replacing parts for hood (Sheet 2 of 2)

Table 6.2 list of replacing parts for hood

No	Name	Parts No
1	Side door	T03 002 00
2	Constant temperature hood	T03 003 00
3	Front door	T03 004 00
4	Window touch head	03 013 00
5	I. V. soft port	T03 001 00
6	Spanner	T03 006 00
7	Spanner bolt	T03 007 00
8	Column compressed spring	T03 008 00
9	Hexagon nut M5	See standard No
10	Lock of box gemel seat	T03 009 00
11	Cross groove countersunk head bolt M4×12	See standard No
12	Spring washer 4	See standard No
13	Hexagon nut M4	See standard No
14	Seal nail	T03 010 00
15	Perforative peg	T03 011 00
16	Lock of box	T03 012 00
17	Side door gemel seat	T03 013 00
18	Place-bolt	T03 014 00
19	Front door gemel seat	T03 015 00
20	Latch seat	03 023 00
21	Cross groove head bolt M3×25	See standard No
22	Access door	03 010 00
23	Seal	T03 016 00
24	Front door heat insulation	T03 017 00
25	Cross groove oblate head bolt M3×18	See standard No
26	Cross groove oblate head bolt M3×10	See standard No
27	Window's shaft	03 020 00
28	Door spring	T03 018 00
29	Access door's cuff	03 033 00

Table 6.2 list of replacing parts for hood ( continue)

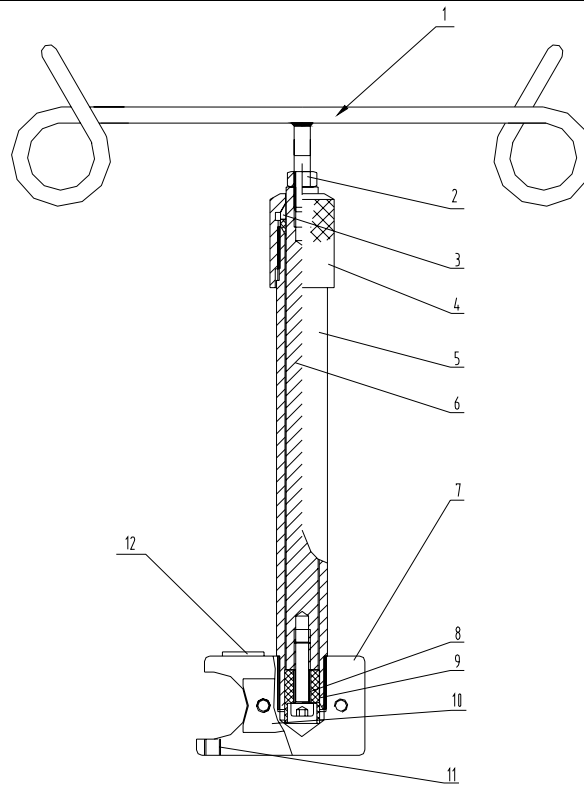
No	Name	Parts No
30	Access door's sleeve	03 032 00
31	O type seal circle 8.5×1.8	See standard No
32	Column 3×30	See standard No
33	Peg agaist hood	03 026 00
34	Rolling lock	03 028 00
35	Spring (1)	03 025 00
36	Latch handle	03 024 00
37	Ring assembly	03 017 00
38	Cross groove head bolt ST2.9×9.5	See standard No
39	M3 bolt cover	03 051 00
40	Terminal door heat insulation	T03 005 00
41	Fixing circle	03 018 00
42	Iris port	03 019 00
43	Plastic sleeve of hand port	03 004 00
44	Cross groove countersunk head bolt M4×8	See standard No



FLOW CHART 6.3 Replacing parts for box body about incubator

Table 6.3 list of replacing parts for incubator

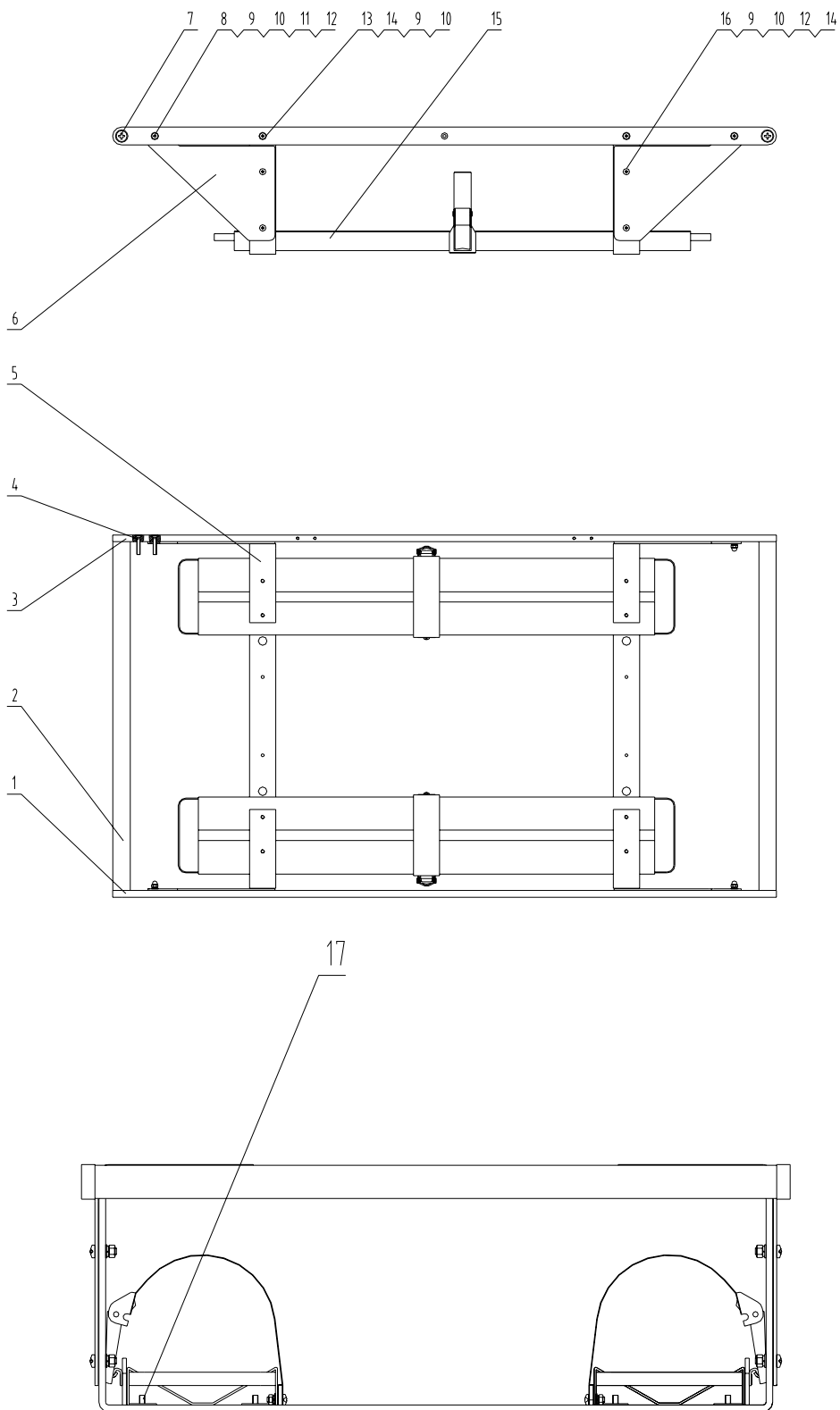
No	Name	Parts No
1	Incubator body	T04 007 00
2	Spring board	T04 008 00
3	Cross groove head bolt M4 × 14	See standard No
4	Flat washer 4	See standard No
5	Spring washer 4	See standard No
6	Hexagon nut M4	See standard No
7	Seal washer	T04 011 00
8	Iron slice for fixing bed	T04 012 00
9	Cross groove countersunk head bolt M4 × 16	See standard No
10	heat preservation board δ 5	T04 013 00
11	Bed puller	T04 014 00
12	Underlying board for clambering base	T04 015 00
13	Clambering base	T04 016 00
14	Cross groove countersunk head bolt M3 × 10	See standard No
15	Spring slice bolt	T04 017 00
16	Reservoir bar	T04 018 00
17	Label for humidity sponge	T04 019 00



FLOW CHART 6.4 Replacing parts for I.V. Pole Groupware

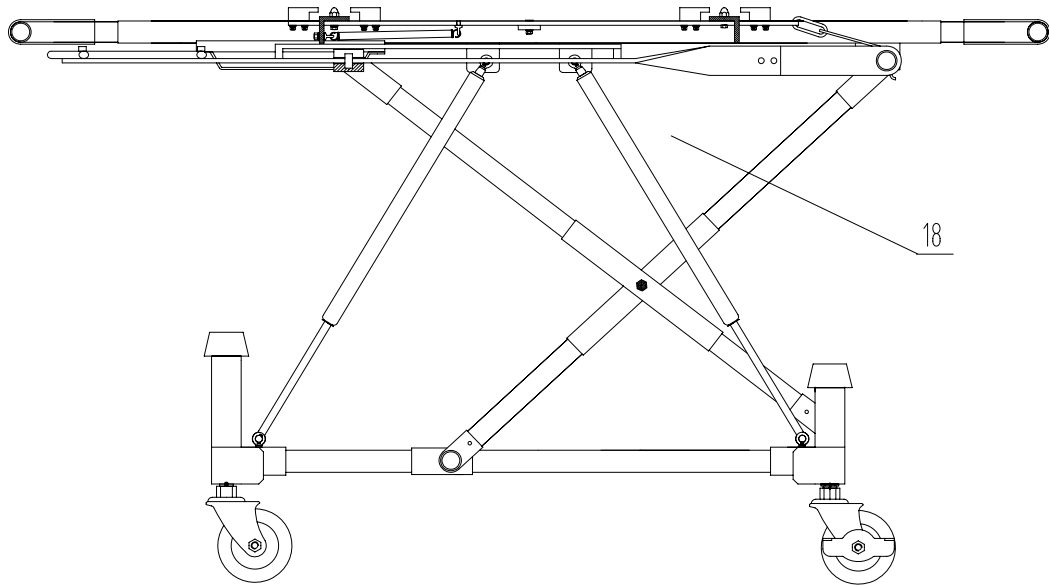
Table 6.4 list of replacing parts for I.V. Pole Groupware

No	Name	Parts No
1	Hook groupware	P05 008 00
2	Hesagon nut M6	See standard No
3	Hoop nut	T05 002 00
4	Hoop circle	T05 003 00
5	I.V. column	T05 004 00
6	I.V. pillar	T05 005 00
7	I.V. seat	T05 006 00
8	Inner hexagon head bolt M6×20	See standard No
9	Place limit head	T05 007 00
10	Pad	T05 008 00
11	Clamp bolt M6×6	See standard No
12	Label for weight of I.V.Pole	T05 009 00



FLOW CHART 6.5 Replacing parts for stand (Sheet 1 of 2)

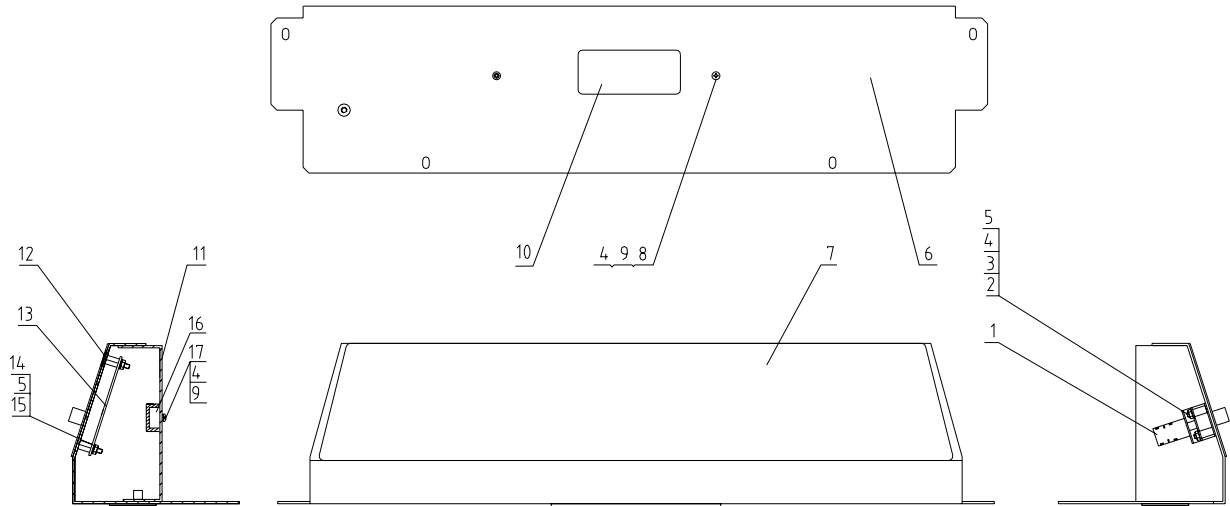




FLOW CHART 6.5 Replacing parts for stand (Sheet 2 of 2)

Table 6.5 list of replacing parts for stand

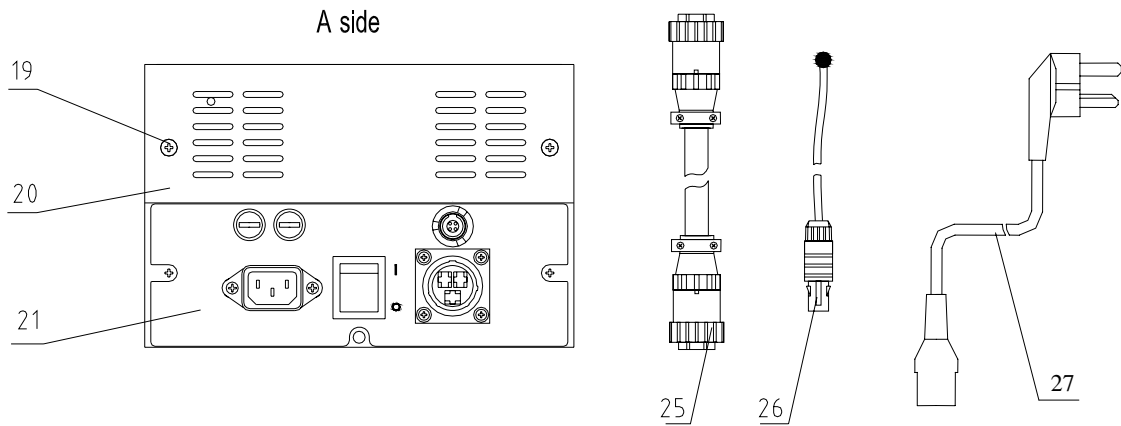
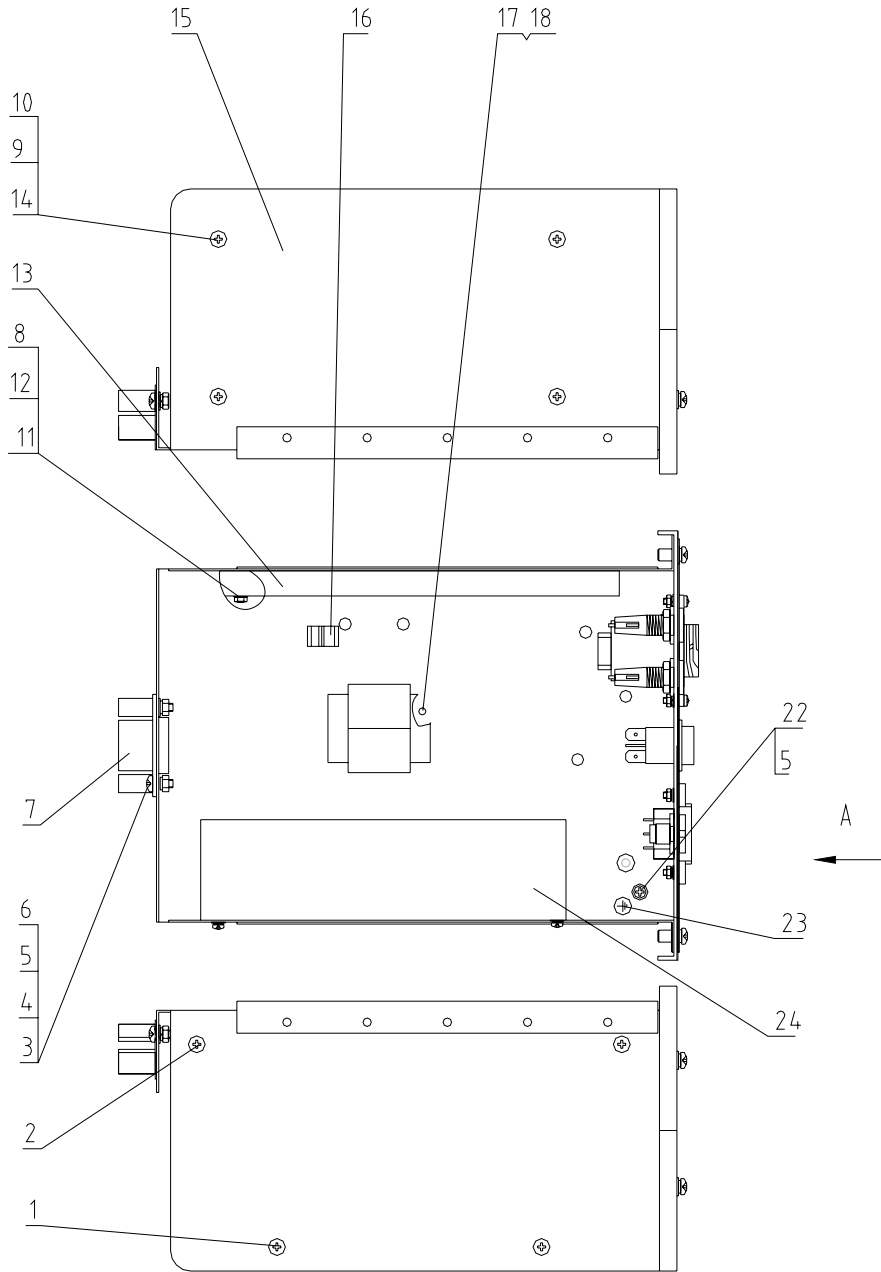
No	Name	Parts No
1	Front bar	T01 002 00
2	crosspiece	T01 003 00
3	Back bar	T01 004 00
4	Cross groove countersunk head bolt M5 × 25	See standard No
5	Main frame	T01 005 00
6	Support board	T01 006 00
7	Cross groove countersunk head bolt M8 × 20	See standard No
8	Cross groove countersunk head bolt M5 × 18	See standard No
9	Spring washer 5	See standard No
10	Flat washer 5	See standard No
11	Cover type nutM5	See standard No
12	Outer sawtooth clamping washer 5	See standard No
13	Cross groove countersunk head bolt M5 × 20	See standard No
14	Hexagon nut M5	See standard No
15	Oxygen cylinder capper	T01 007 00
16	Cross groove oblate head bolt M5 × 16	See standard No
17	Cross groove countersunk head bolt M4 × 10	See standard No
18	trolley	T01 001 00



**FLOW CHART 6.6 Replacing parts for temperature control (Sheet 1 of 3)**

**Table 6.6 list of replacing parts for temperature control**

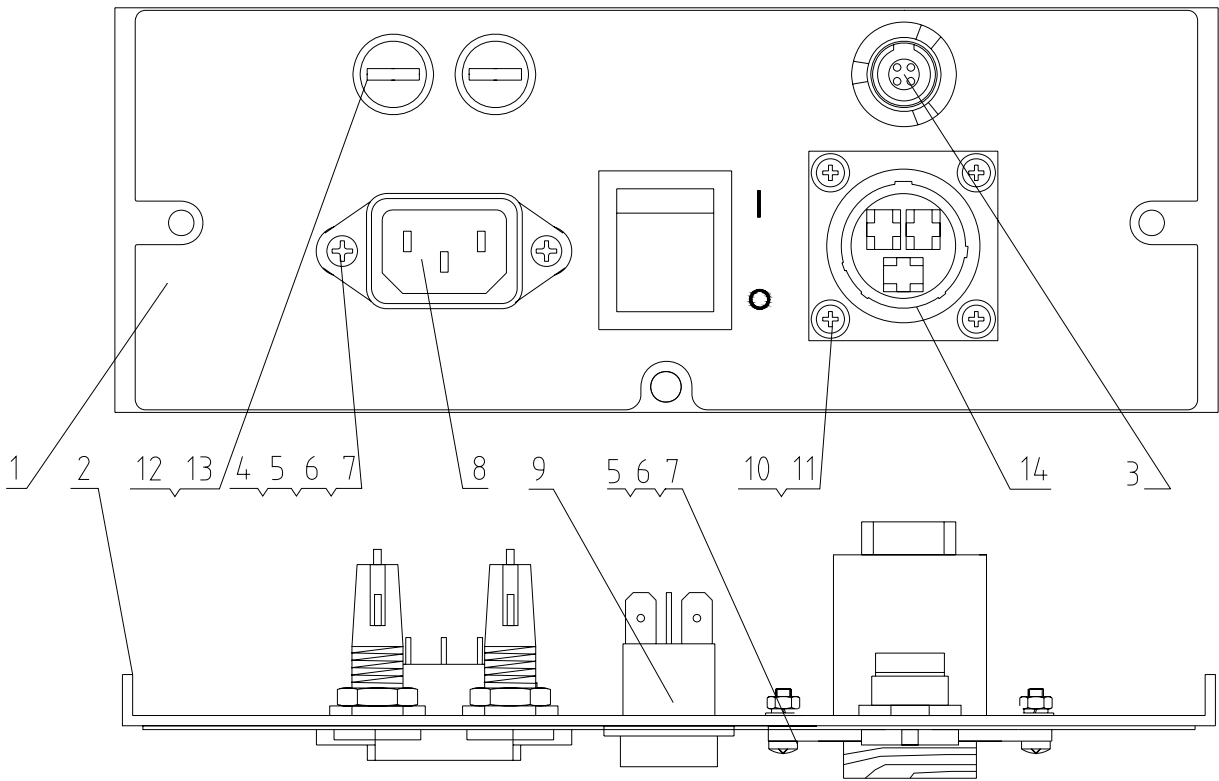
No	Name	Parts No
1	Switch group ware for control	T02 006 00
2	Cross groove countersunk head bolt M3×25	See standard No
3	Hexagonal spacer support HTP-315	T02 007 00
4	Spring washer 3	See standard No
5	Hexagon nut M3	See standard No
6	Frame	T02 004 00
7	Control board	T02 005 00
8	Cross groove head bolt M3×8	See standard No
9	Flat washer 3	See standard No
10	Electrical device name plate	T02 003 00
11	Shield cover groupware	T02 028 00
12	Cross groove countersunk head bolt M3×6	See standard No
13	Main board	T02 008 00
14	Hexagonal spacer support HTS-308	Y01 016 00
15	Plastic washer	P02 030 00
16	Battery box	02 028 00
17	Cross groove head bolt M3×8	See standard No



FLOW CHART 6.7 Replacing parts for temperature control (Sheet 2 of 3)

Table 6.7 list of replacing parts for temperature control(continue)

No	Name	Parts No
1	Cross groove countersunk head bolt M3×8	See standard No
2	Cross groove countersunk head bolt M3×6	See standard No
3	Cross groove head bolt M4×16	See standard No
4	Flat washer 4	See standard No
5	Spring washer 4	See standard No
6	Hexagon nut M4	See standard No
7	Connecting group ware of storage battery A	T02 009 00
8	Hexagon nut M3	See standard No
9	Spring washer 3	See standard No
10	Flat washer 3	See standard No
11	Hexagonal spacer support HTS-306	T02 011 00
12	Plastic washer	P02 030 00
13	Power board	T02 013 00
14	Cross groove head bolt M3×8	See standard No
15	Electrical box	T02 014 00
16	Wiring fastening clip of 2 segments TS-0607	T02 030 00
17	Cross groove countersunk head bolt ST2.9×9.5	See standard No
18	Choke groupware	T 02 026 00
19	Cross groove head bolt M4×8	See standard No
20	Top baffle	T02 017 00
21	Bottom baffle groupware	T02 032 00
22	Cross groove head bolt M4×8	See standard No
23	Grounded poster	02 017 00
24	Power switch MMK320S-15	T02 020 00
25	DC Power Cord	T02 002 00
26	Skin Temperature Sensor	T02 024 00
27	AC Power Cord	02 030 00



FLOW CHART 6.8 Replacing parts for temperature control (Sheet 3 of 3)

Table 6.8 list of replacing parts for temperature control (continue)

No	Name	Parts No
1	Lower poster for elctrical device	T02 021 00
2	Lower cover baffle	T02 022 00
3	Sensor support	T02 023 00
4	Cross groove countersunk head bolt M3×10	See standard No
5	Hexagon nut M3	See standard No
6	Spring washer 3	See standard No
7	Outer sawtoothclamp washer 3	See standard No
8	Power socket 3GTJE1	T02 025 00
9	Green light switch RK1-01C/N 2×2	Y02 022 00
10	Flat washer 3	See standard No
11	Cross groove head bolt M3×10	See standard No
12	Fuse F6.3AL/250V	T02 027 00
13	Fuse seat R3-11	Y02 025 00
14	Group ware power socket	T02 012 00

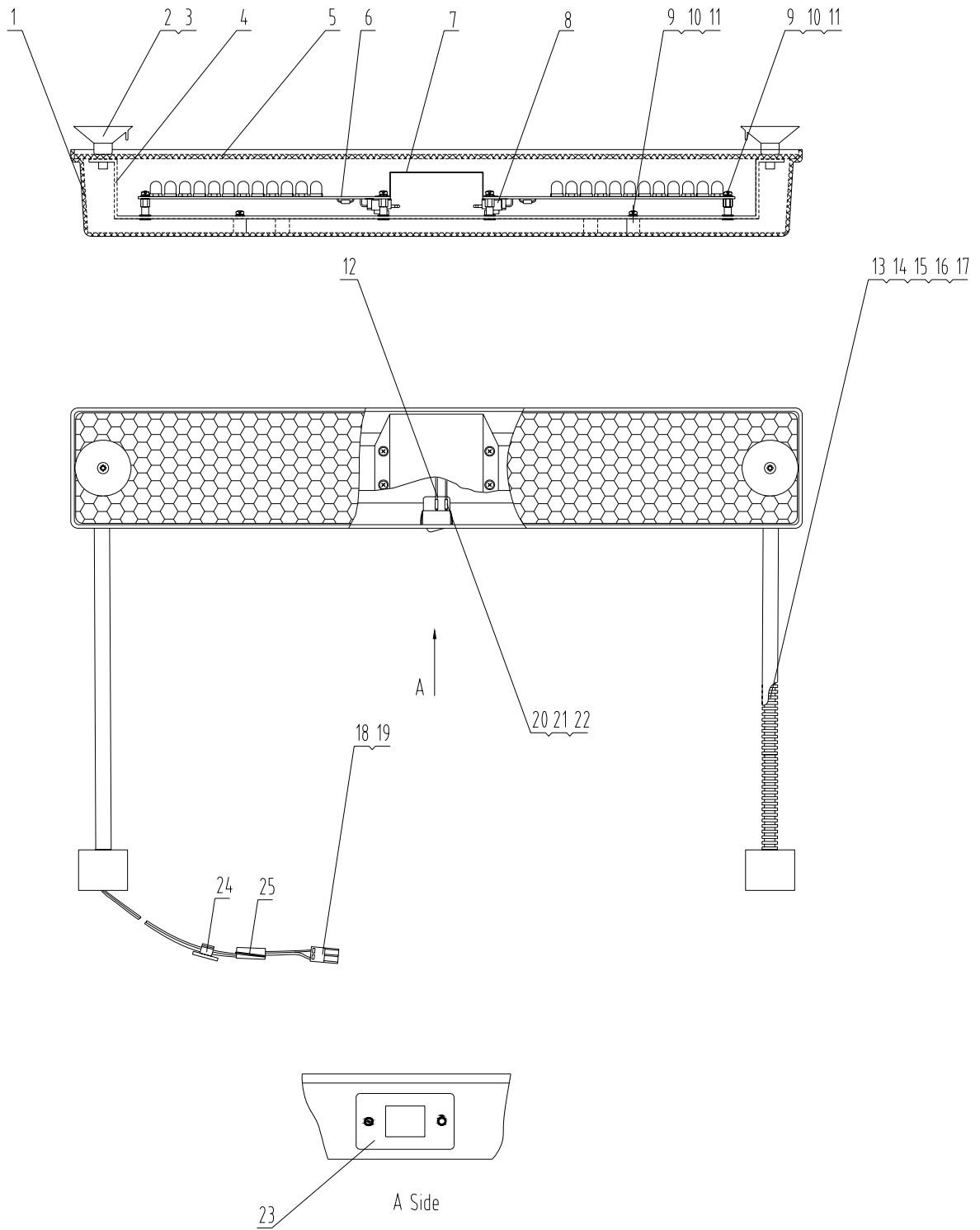


Figure 6.9 Replacement spare parts figure of jacklight

Table 6.9 Replacement spare parts table of jacklight

No	Name	Parts No
1	Blue box shell	T06 001 00
2	Absorbing feet	T06 002 00
3	Cross groove counter head bolt M4×16	See standard No
4	Light frame board	T06 003 00
5	Cover board	T06 004 00
6	Lamp group	T06 005 00
7	Protection slice	T06 006 00
8	Socket XY4-2S	T06 007 00
9	Cross groove counter head bolt M3×8	See standard No.
10	Flat washer 4	See standard No
11	Spring washer 4	See standard No
12	Switch MK321A/77	T06 008 00
13	Flat washer 10	See standard No
14	Hexagon thin nut M10×1	See standard No
15	Snake tube $\phi$ 11×270	T06 010 00
16	Light feet	T06 011 00
17	White heat shrinking cannula 16	T06 012 00
18	Double parelell lines L1	T06 013 00
19	Plug MC100-50802	T06 014 00
20	Double parelell lines L2, L3	T06 015 00
21	Rectangular faucet JXCK-6. 3	T06 016 00
22	Plastic jacket SLHT-6. 3	T06 017 00
23	Switch poster	T06 009 00
24	Fixing clip	P04 047 00
25	Circular ferrite	T06 019 00



Table 6.10 list of replacing parts for standard parts

No	Name	Parts No
1	Cross groove bolt M3×6	BZ 001
2	Cross groove bolt M3×8	BZ 002
3	Cross groove bolt M3×25	BZ 006
4	Cross groove bolt M4×8	BZ 007
5	Cross groove bolt M4×16	BZ 010
6	Cross groove countersunk head bolt M3×5	BZ 016
7	Cross groove countersunk head bolt M3×6	BZ 017
8	Cross groove countersunk head bolt M3×8	BZ 018
9	Cross groove countersunk head bolt M3×10	BZ 019
10	Cross groove countersunk head bolt M4×8	BZ 022
11	Cross groove countersunk head bolt M4×12	BZ 023
12	Cross groove countersunk head bolt M4×16	BZ 024
13	Cross groove countersunk head bolt M5×18	BZ 025
14	Cross groove countersunk head bolt M5×20	BZ 026
15	Cross groove bolt ST2.9×9.5	BZ 031
16	Flat washer 3	BZ 036
17	Flat washer 4	BZ 037
18	Flat washer 5	BZ 038
19	Flat washer 10	BZ 041
20	Spring washer 3	BZ 043
21	Spring washer4	BZ 044
22	Spring washer 5	BZ 045

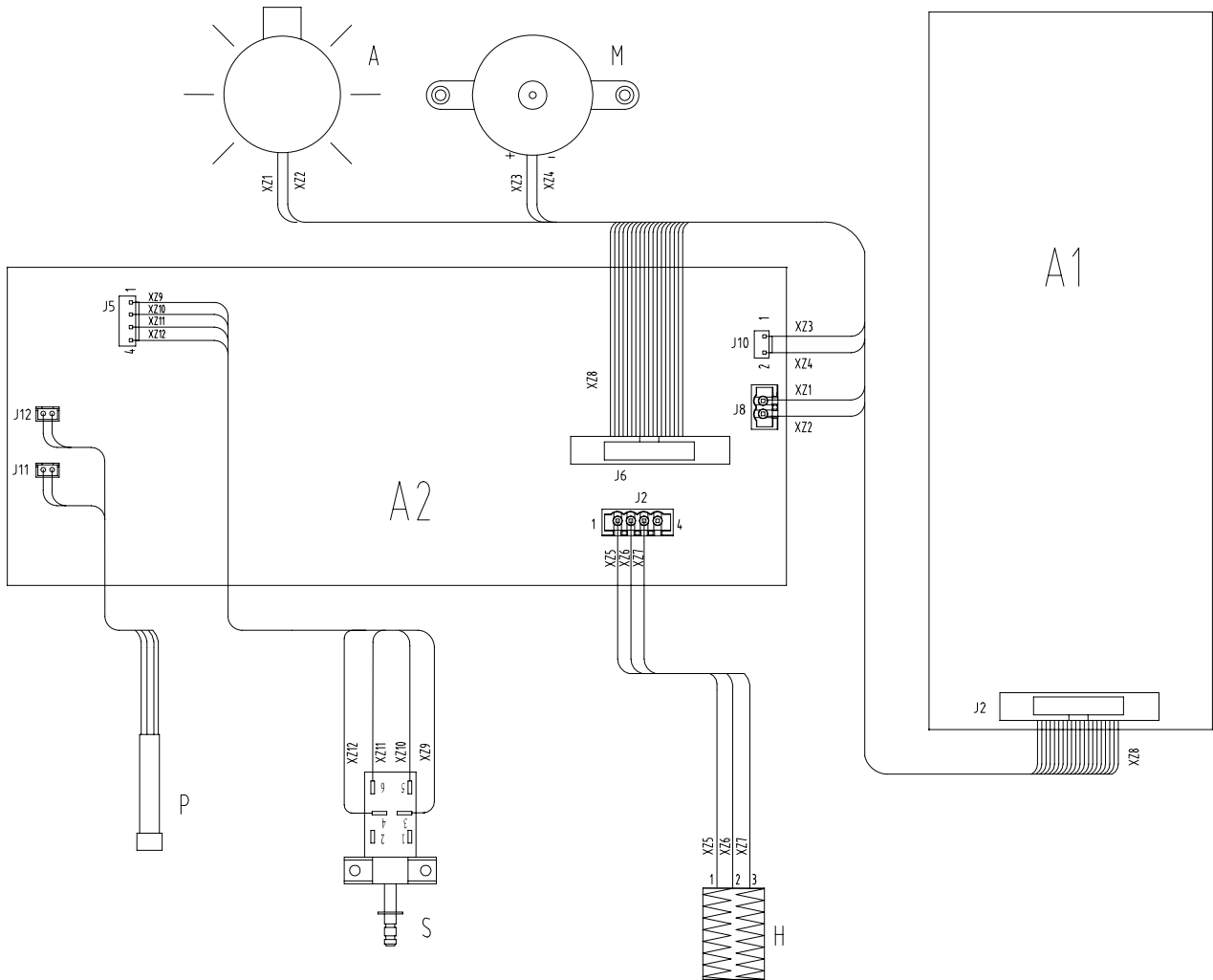
Table 6.10 list of replacing parts for standard parts (continue)

No	Name	Parts No
23	Paper washer 3	BZ 050
24	Outer sawtoothclamp washer 5	BZ 051
25	Hexagon nut M3	BZ 053
26	Hexagon nut M4	BZ 054
27	Hexagon nut M5	BZ 055
28	Hexagon nut M6	BZ 056
29	O type seal circle $\phi 8.5 \times 1.8$	BZ 067
30	Column $3 \times 30$	BZ 072
31	Cover type nutM5	BZ 094
32	Cross groove bolt $M4 \times 14$	BZ 098
33	Outer sawtoothclamp washer 3	BZ 102
34	Cross groove oblate head bolt $M3 \times 10$	BZ 106
35	Cross groove oblate head bolt $M5 \times 16$	BZ 115
36	Cross groove oblate head bolt $M3 \times 18$	BZ 126
37	Cross groove countersunk head bolt $M8 \times 20$	BZ 127
38	Cross groove countersunk head bolt $M3 \times 25$	BZ 128
39	Inner hexagon bolt $M6 \times 20$	BZ 135
40	Hexagon thin nut $M10 \times 1$	BZ 145
41	Inner hexagon bolt $M6 \times 8$	BZ 152
42	Cross groove oblate head bolt $M4 \times 8$	BZ 153
43	Clamp bolt $M6 \times 6$	BZ 156

## SECTION 7 DIAGRAMS

### 7.1 GENERAL

The section provides schematic and wiring diagrams for Incubator and circuit diagrams, connection diagram for temperature controller boards.

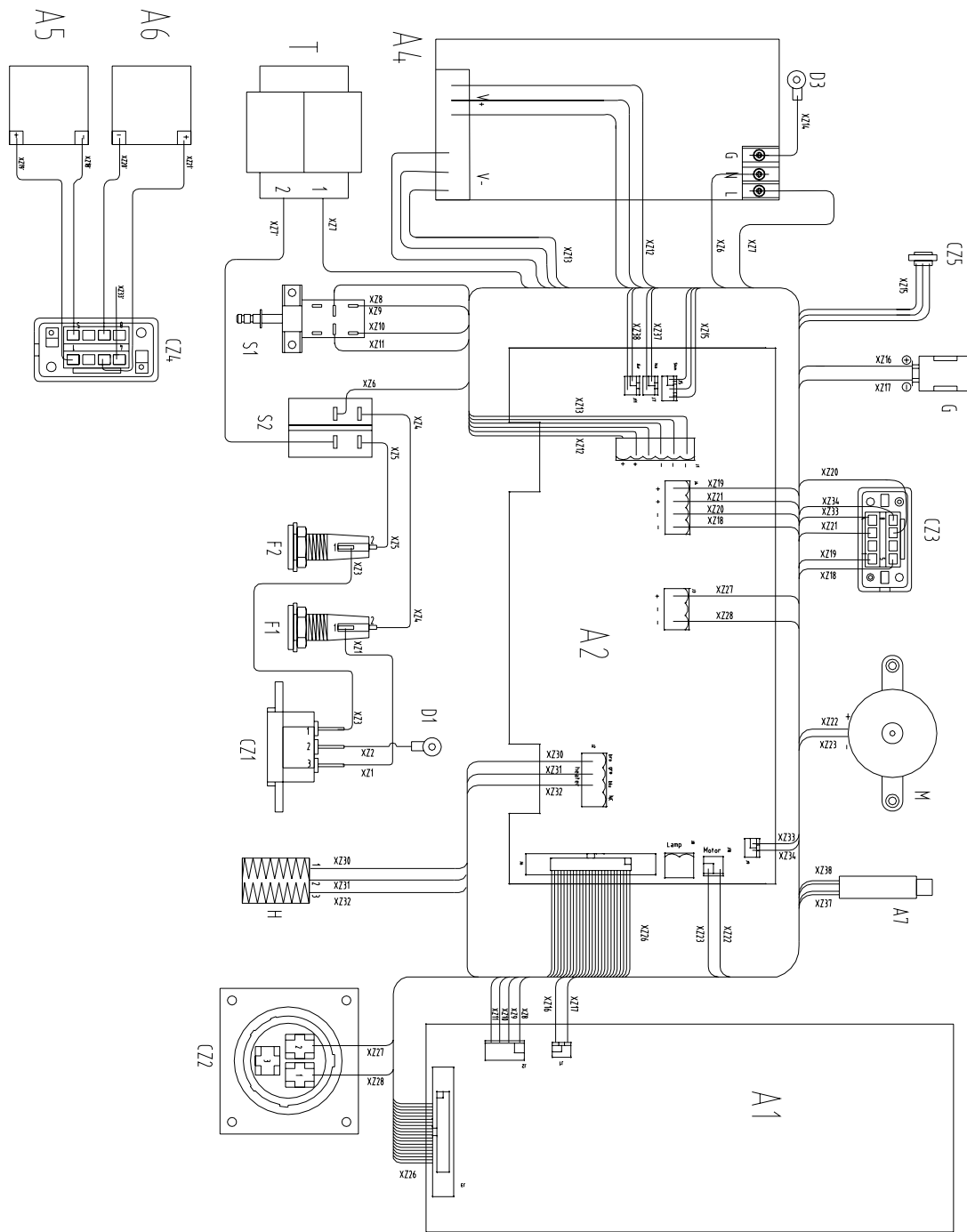


A1: control board  
 A: illumination lamp  
 S: switch for controller

A2: power board  
 H: groupware of heater

M: fan motor  
 P: sensor

DIAGRAM OF WHOLE UNIT



CZ1: AC Power Supply Receptacle

CZ2: DC Power Supply Receptacle

CZ3,CZ4: Storage battery Receptacle

A1: The Main control Board

A2: Power Supply Board

CZ5: socket of sensor

A4: Power switch MMK320S-15

A5, A6: Storage battery TP12-26

D1, D3: Connect Piccc

A7: Air temp or isolated over-temp sensor

F1, F2: 3.15A/250V F type fuses

H: Heater

M: Heater Fan Motor and Impeller D825E-B-05HB-CCW

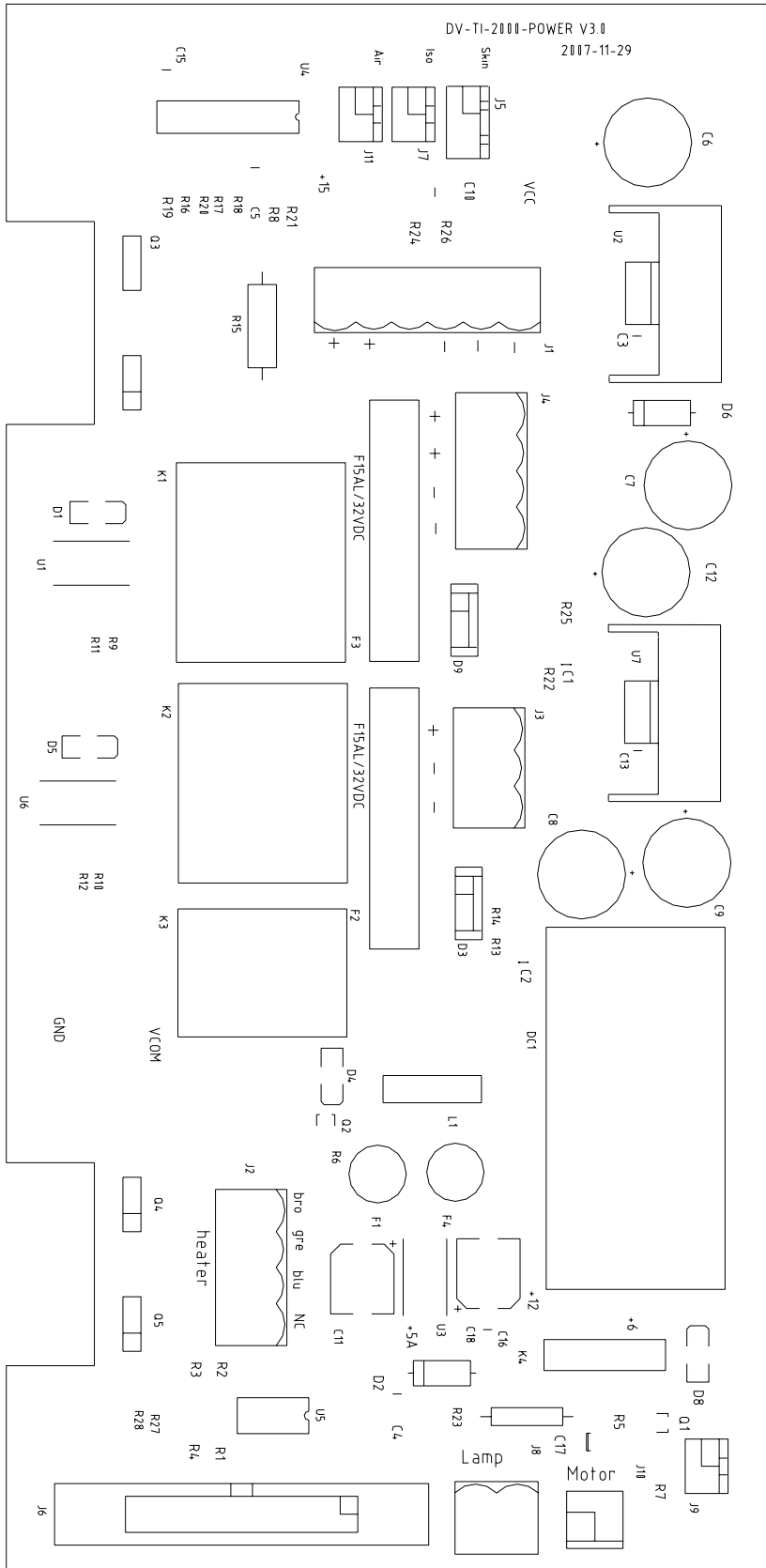
S1: Temperature Controller Switch PWL-2P2T

S2: Main Power Supply switch C1353ALG-H

G: GP17-R8H Ni-MH 8.4V/170mAh Rechargeable battery

T: Choke QQ3220

**INTERCONNECTION DIAGRAM OF TEMPERATURE CONTROLLER**



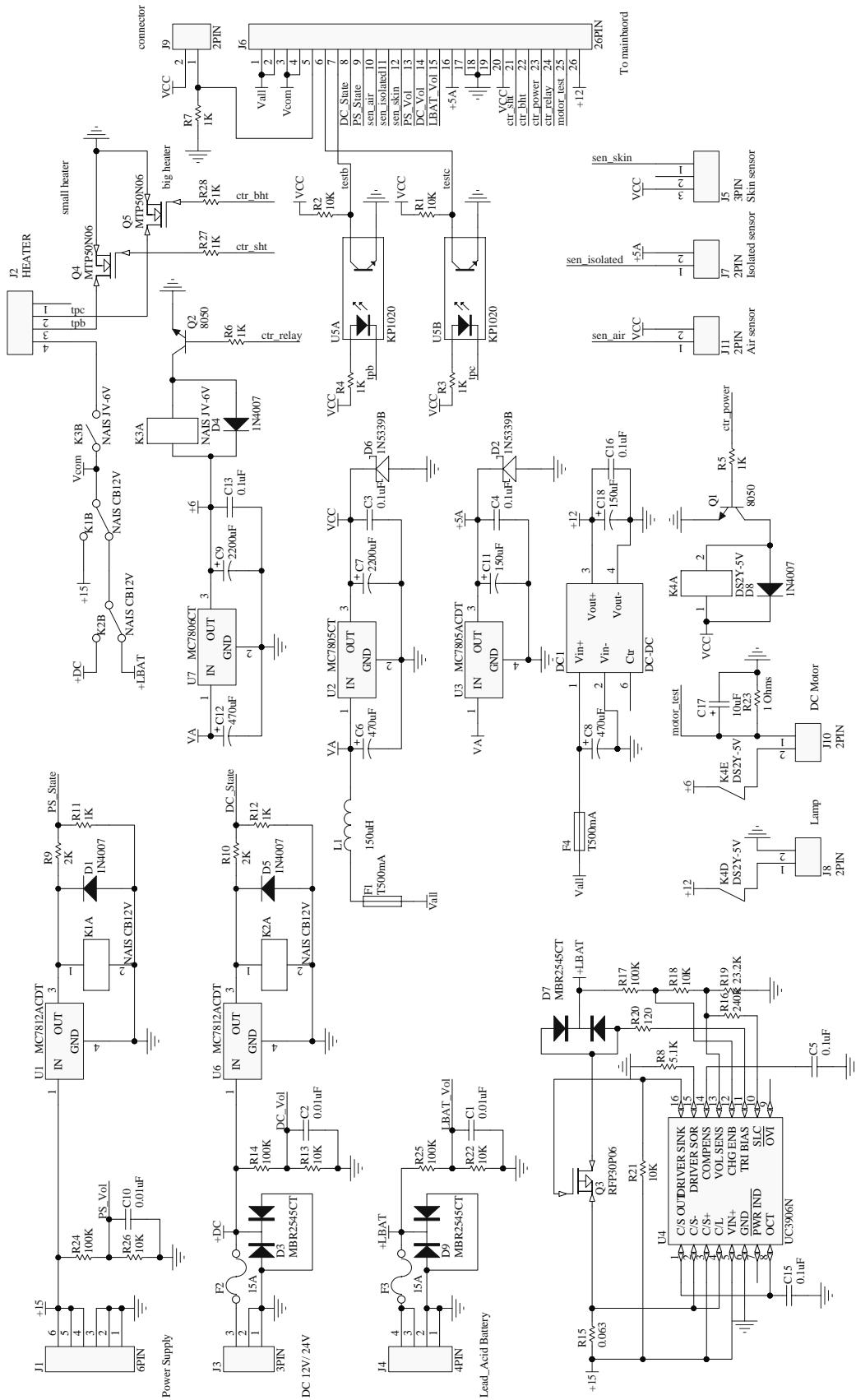
POWER BOARD ASSY DIAGRAM

## POWER BOARD ASSY PARTS LIST

NO.	Model Code	Name and Specification	Quantity
1	R1,R2,R21	Resistor 0805-10K $\Omega$ $\pm$ 5%	3
2	R3~R7,R11,R12,R27,R28	Resistor 0805-1K $\Omega$ $\pm$ 5%	9
3	R8	Resistor 0805-5.1K $\Omega$ $\pm$ 5%	1
4	R9,R10	Resistor 0805-2K $\Omega$ $\pm$ 5%	2
5	R13,R18,R22,R26	Resistor 0805-10K $\Omega$ $\pm$ 1%	4
6	R14,R17,R24,R25	Resistor 0805-100K $\Omega$ $\pm$ 1%	4
7	R15	Resistor RJ-2-0.063 $\Omega$ $\pm$ 1%	1
8	R16	Resistor 0805-240K $\Omega$ $\pm$ 1%	1
9	R19	Resistor 0805-23.2K $\Omega$ $\pm$ 1%	1
10	R20	Resistor 0805-120 $\Omega$ $\pm$ 5%	1
11	R23	Resistor RJ-1-1 $\Omega$ $\pm$ 1%	1
12	C1,C2,C10	Capacitor 0805-0.01 $\mu$ F $\pm$ 20%	3
13	C3,C4,C5,C13,C15,C16	Capacitor 0805-0.1 $\mu$ F $\pm$ 20%	6
14	C6,C8,C12	Capacitor CD11-50V-470 $\mu$ F $\pm$ 20%	3
15	C7,C9	Capacitor CD11-16V-2200 $\mu$ F $\pm$ 20%	2
16	C11,C18	Capacitor SMD-25V-150 $\mu$ F $\pm$ 20%	2
17	C17	Capacitor CA45B-16V-10 $\mu$ F $\pm$ 20%	1
18	D1,D4,D5,D8	Diode SM4007-D0214	4
19	D2,D6	Diode 1N5339B	2
20	D3,D7,D9	Diode MBR2545CT	3
21	Q1,Q2	Triode MMBT3904LT1	2
22	Q3	MOS Pipe RFP30P06	1
23	Q4,Q5	MOS Pipe MTP50N06	2

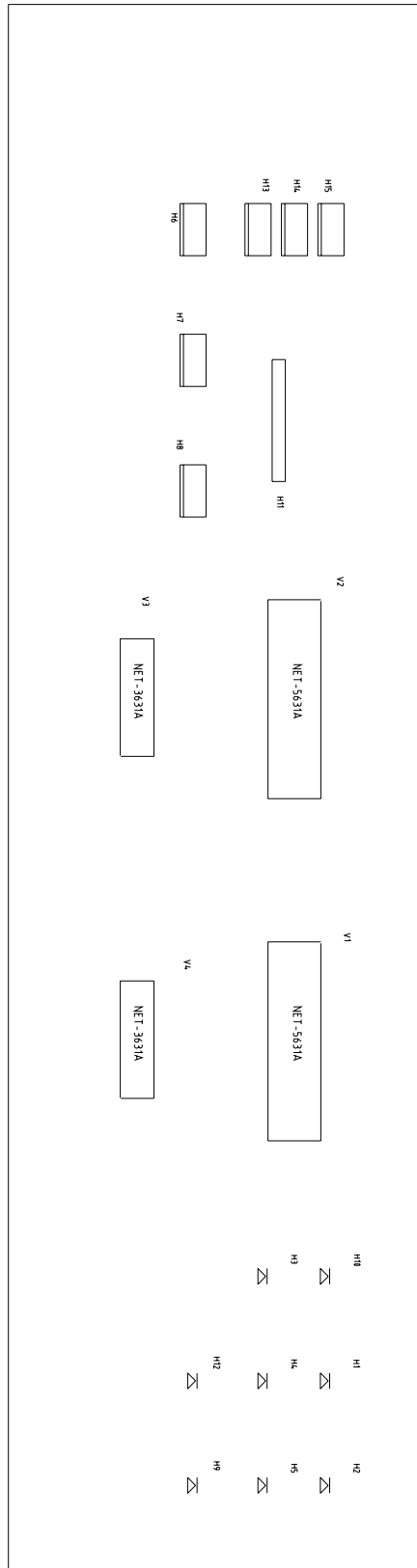
## POWER BOARD ASSY PARTS LIST (CONTINUE)

NO.	Model Code	Name and Specification	Quantity
24	U1,U6	Integrated circuit MC7812BDTG	2
25	U2	Integrated circuit MC7805CT	1
26	U3	Integrated circuit MC7805BDTG	1
27	U4	Integrated circuit UC3906N	1
28	U5	Integrated circuit KP1020	1
29	U7	Integrated circuit MC7806CT	1
30	DC1	DC-DC ASD10H-12S12	1
31	F1,F4	Fuse T 500mAL/250V	2
32	F2,F3	Fuse F 15AL/32V-C	2
33	L1	Inductance 150uH	1
34	K1,K2	Relay CB1-P-12V	2
35	K3	Relay JV1aP-6V	1
36	K4	Relay DS2Y-S-DC5V	1
37	J1	Socket ME040-50806	1
38	J2,J4	Socket ME040-50804	2
39	J3	Socket ME040-50803	1
40	J5	Socket XY2.5-3S	1
41	J6	Socket DC-2-26S	1
42	J7,J9,J11	Socket XY2.5-2S	3
43	J8	Socket ME040-50802	1
44	J10	Socket XY4-2S	1
45		Radiator GHSI-35	2

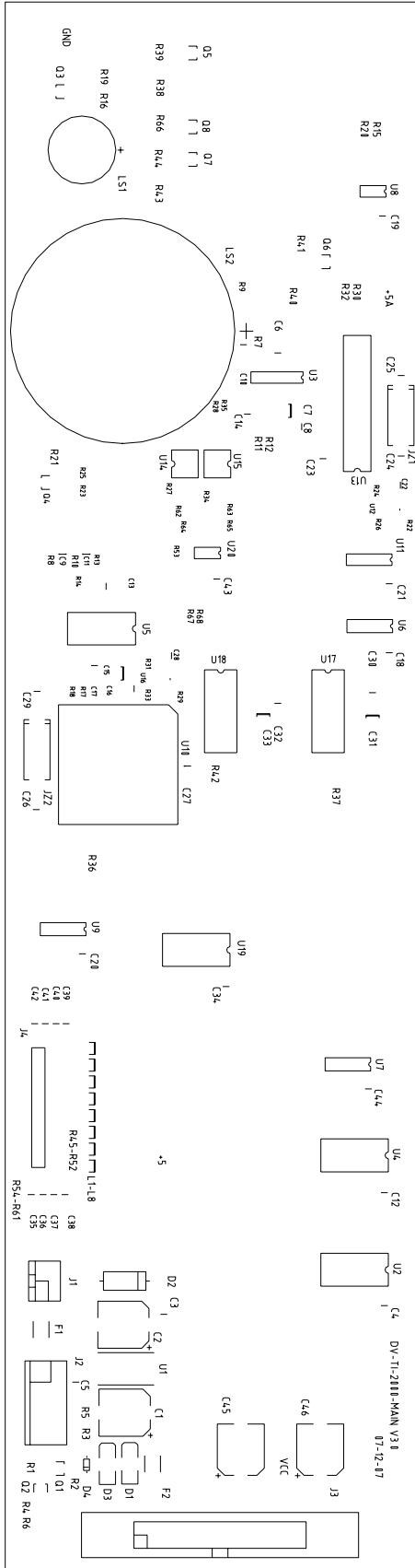


POWER BOARD SCHEMATIC DIAGRAM





THE MAIN BOARD ASSY DIAGRAM 1



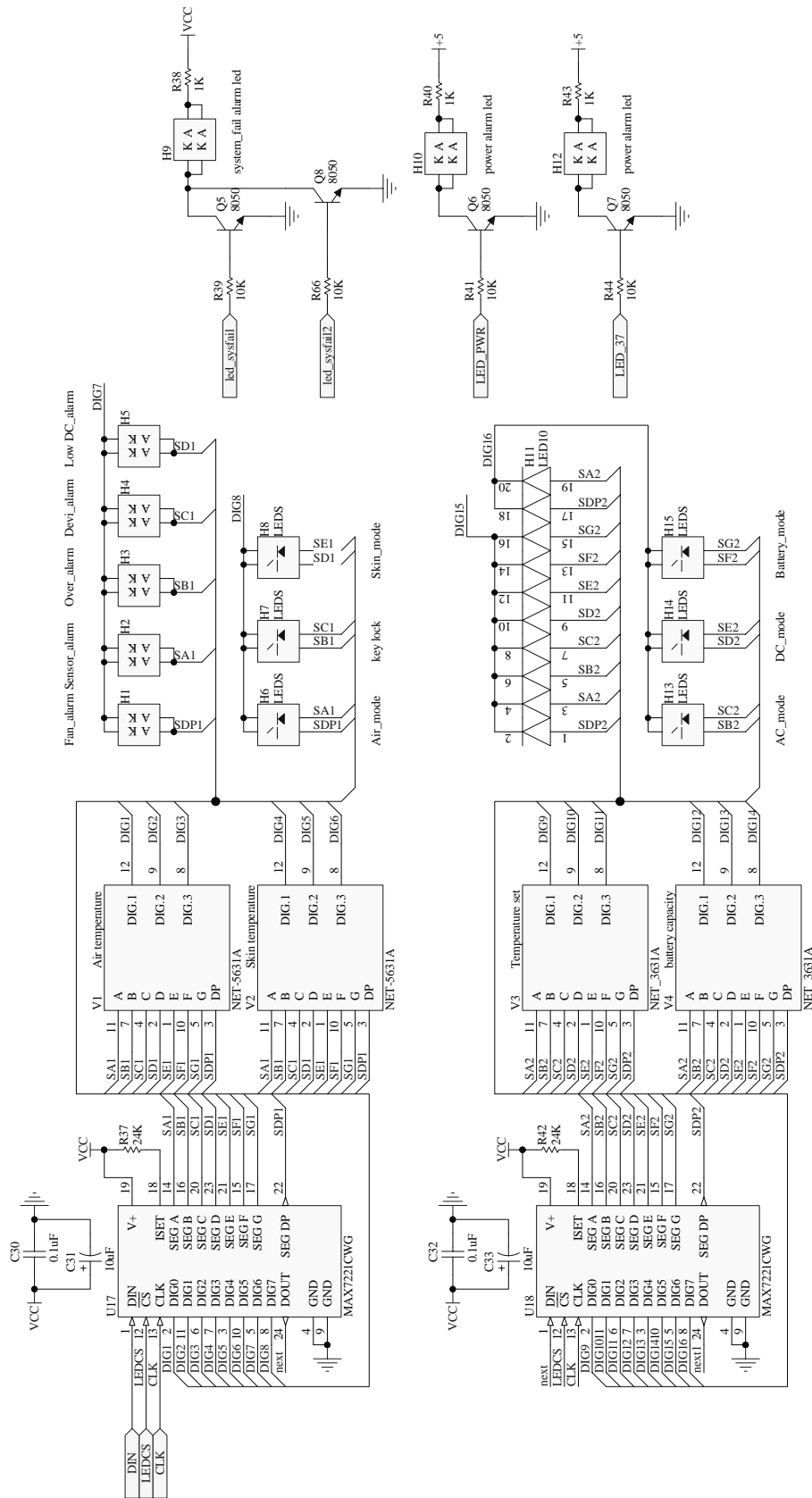
THE MAIN BOARD ASSY DIAGRAM 2

## THE MAIN BOARD ASSY PARTS LIST

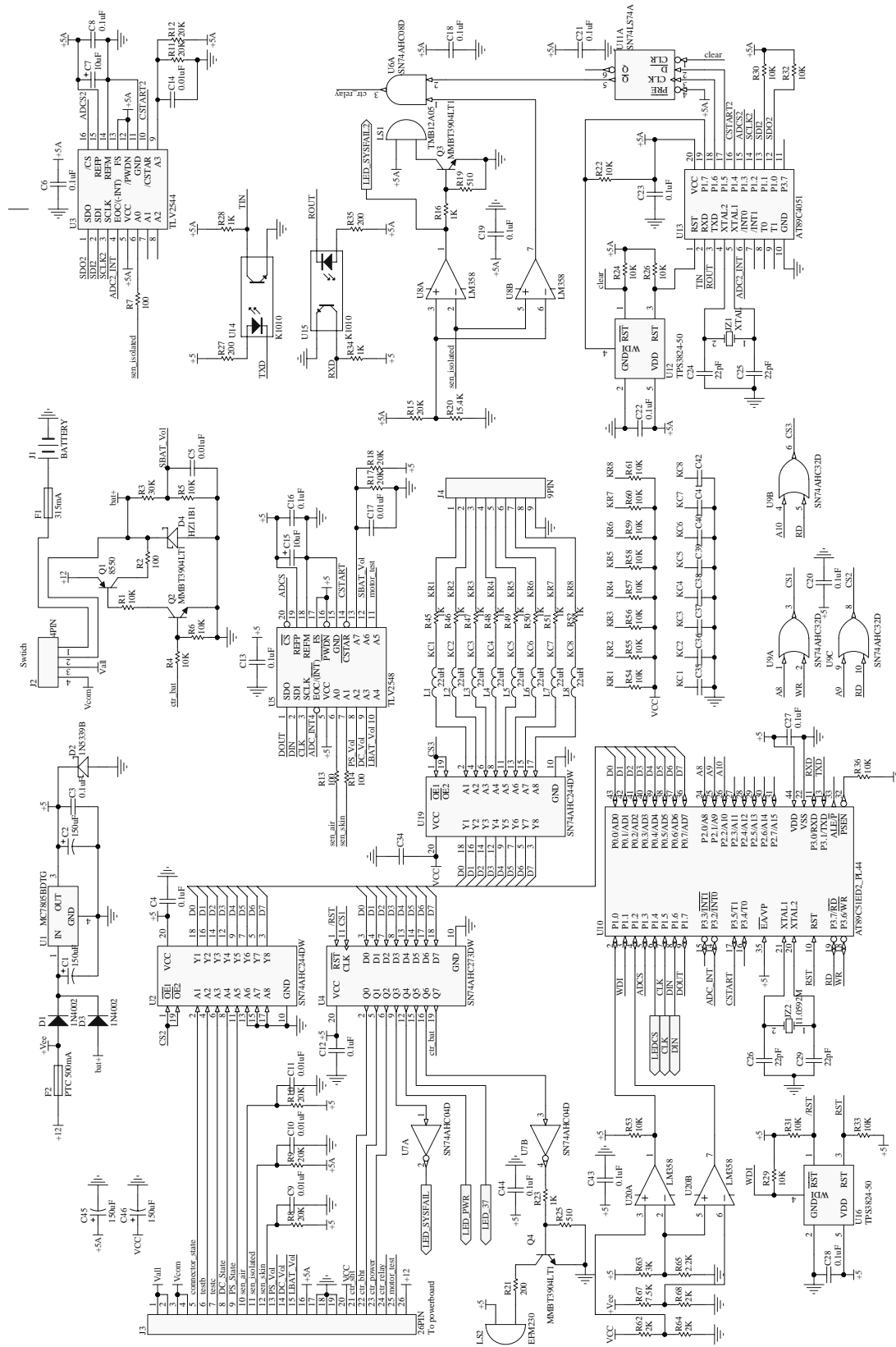
NO.	Model Code	Name and Specification	Quantity
1	R2,R7,R13,R14	Resistor 0805-100K $\Omega$ $\pm$ 5%	4
2	R3	Resistor 0805-30K $\Omega$ $\pm$ 1%	1
3	R21,R27,R35	Resistor 0805-10K $\Omega$ $\pm$ 1%	3
4	R20	Resistor 0805-15.4K $\Omega$ $\pm$ 1%	1
5	R8~R12,R17,R18,R15	Resistor 0805-20K $\Omega$ $\pm$ 1%	8
6	R16,R23,R28,R34,R45~R52	Resistor 0805-1K $\Omega$ $\pm$ 5%	12
7	R19,R25	Resistor 0805-510 $\Omega$ $\pm$ 5%	2
8	R21,R27,R35	Resistor 0805-200 $\Omega$ $\pm$ 5%	3
9	R37,R42	Resistor Resistor 0805-24K $\Omega$ $\pm$ 5%	2
10	R38,R40,R43	Resistor 0805-1K $\Omega$ $\pm$ 5%	3
11	R62,R64,R68	Resistor 0805-2K $\Omega$ $\pm$ 1%	3
12	R63	Resistor 0805-3K $\Omega$ $\pm$ 1%	1
13	R65	Resistor 0805-2.2K $\Omega$ $\pm$ 1%	1
14	R67	Resistor 0805-7.5K $\Omega$ $\pm$ 1%	1
15	R1,R4,R6,R22,R24,R26,R29~R33	Resistor 0805-10K $\Omega$ $\pm$ 5%	11
16	R36,R39,R41,R44,R53~R61,R66	Resistor 0805-10K $\Omega$ $\pm$ 5%	14
17	R5	Resistor 0805-10K $\Omega$ $\pm$ 1%	1
18	C1,C2,C45,C46	Capacitor SND-25V-150 uF $\pm$ 20%	4
19	C3,C4,C6,C8,C12,C13,C16	Capacitor 0805- 0.1uF $\pm$ 20%	7
20	C5,C9~C11,C14,C17,C35~C42	Capacitor 0805- 0.01uF $\pm$ 20%	14
21	C7,C15,C31,C33	Capacitor CS458-16V-10uF $\pm$ 20%	4
22	C18~C23,C27,C28,C30	Capacitor 0805- 0.1uF $\pm$ 20%	9
23	C24,C25,C26,C29	Capacitor 0805- 22PF $\pm$ 20%	4
24	C32,C34,C43,C44	Capacitor 0805- 0.1uF $\pm$ 20%	4
25	U1	Integrated Circuit MC7805BDTG	1
26	U2,U19	Integrated Circuit SN74LS244	2
27	U3	Integrated Circuit TLV2544CD	1
28	U4	Integrated Circuit SN74AHC273DW	1
29	U5	Integrated Circuit TLV2548CDW	1
30	U6	Integrated Circuit SN74AHCT08	1

## THE MAIN BOARD ASSY PARTS LIST (CONTINUE)

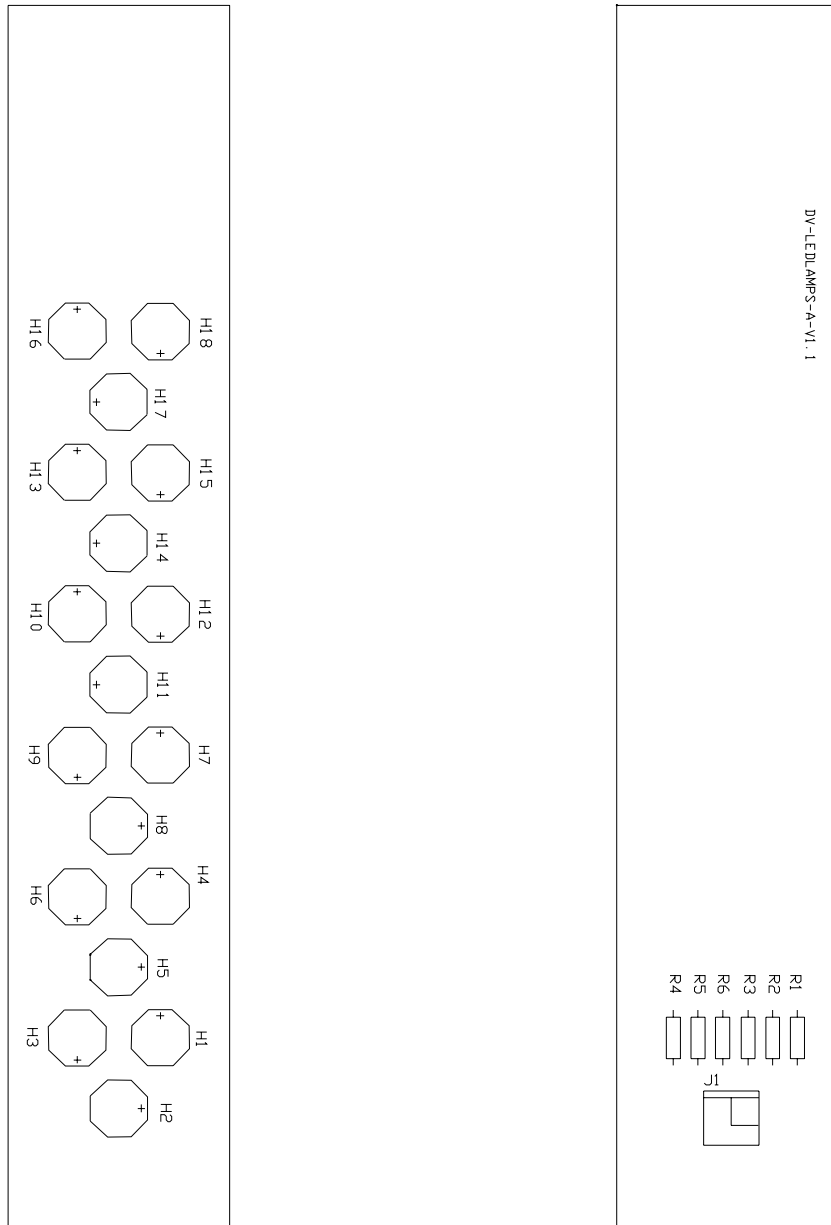
NO.	Model Code	Name and Specification	Quantity
31	U7	Integrated Circuit SN74AHCT04	1
32	U8,U20	Integrated Circuit LM358D	2
33	U9	Integrated Circuit SN74AHCT32D	1
34	U10	Integrated Circuit AT89C51ED2-UM	1
35	U11	Integrated Circuit SN74AHCT74D	1
36	U12,U16	Integrated Circuit TPS3824-50	2
37	U13	Integrated Circuit AT89C4051	1
38	U14,U15	Integrated Circuit K1010	2
39	U17,U18	Integrated Circuit MAX7221CWG	2
40	D1,D3	Diode SM4007-D0214	1
41	D2	Diode 1N5339B	1
42	D4	Diode HZ11B1	1
43	Q1	Triode MMBT3906LT1	1
44	Q2~Q8	Triode MMBT3904LT1	7
45	H1~H5,H9,H10	LED NEA-L10ZAD	7
46	H6~H8,H13~H15	LED HLMP-2500-G	6
47	H11	LED NEA-B10ZAG	1
48	H12	LED NEA-L10ZAU Y	1
49	V1,V2	Digitron NET-5631AG	2
50	V3,V4	Digitron NET-3631AT	2
51	L1~L8	Inductance 1210-22 uH±20%	8
52	JZ1,JZ2	Crystal HC-49/S-SMD-11.0592MHz oscillator	2
53	LS1	Buzzer TMB12A05	1
54	LS2	Buzzer EFM-230/12VDC	1
55	J1	Socket XY2.5-2S	1
56	J2	Socket XY4-4S	1
57	J3	Socket DC-2-26S	1
58	J4	Single line pins DPCZ-60T	9
59	UZ1 (U10)	Socket of integrated circuit PLC-44	1
60	F1,F2	Fuse 1812L050-C	2



THE MAIN BOARD SCHEMATIC DIAGRAM (DISPLAY PART)



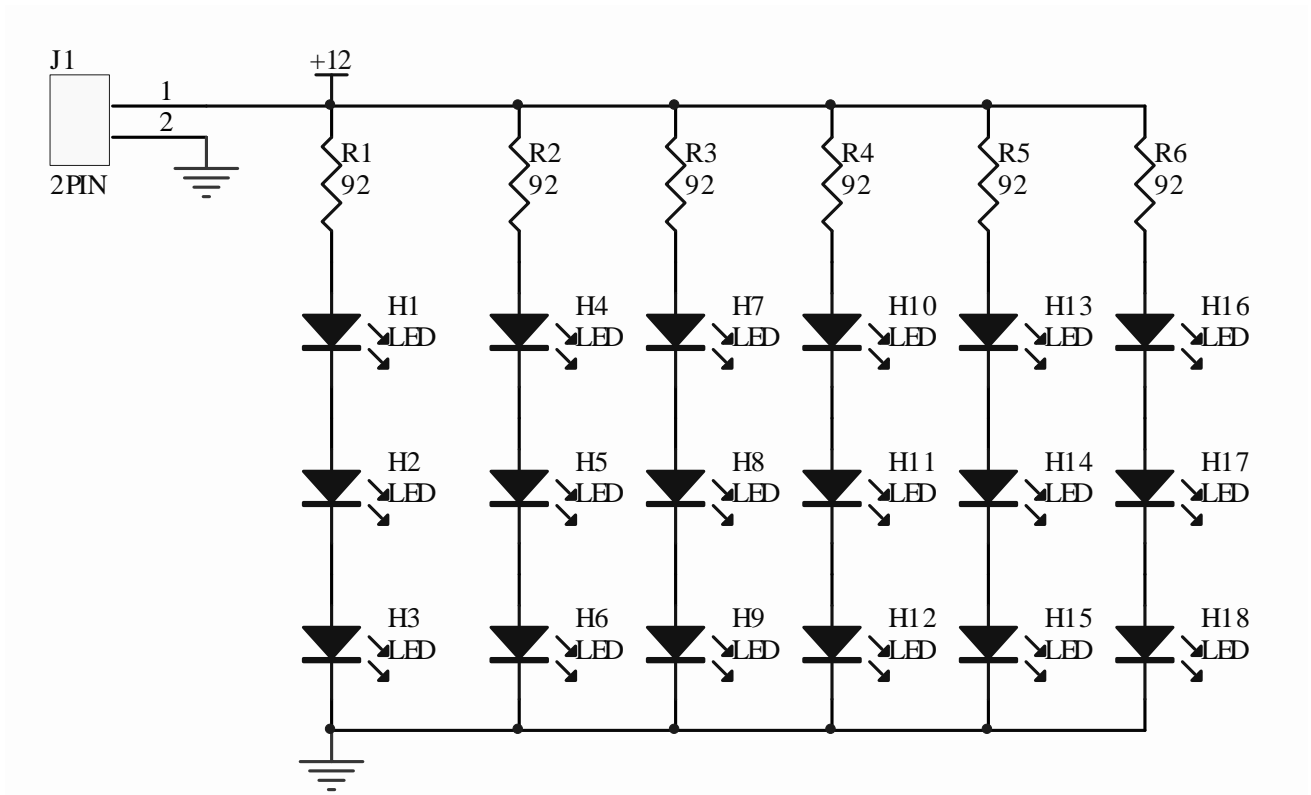
THE MAIN BOARD SCHEMATIC DIAGRAM (CONTROL PART)



LED BOARD ASSY DIAGRAM

LED BOARD ASSY PARTS LIST

NO.	Model Code	Name and Specification	Quantity
1	R1~R6	RJ-0.25W-130kohms±1% Resistor	6
2	J1	XY4-2 Socket (bend)	1
3		φ8 LED RL-804CWC60-0 (High brightness white beam)	18
4		LED bottoem seat	18



LED board principle diagram




## Guidance and declaration-electromagnetic emissions-

Guidance and declaration - electromagnetic immunity		
The model TI-2000 Transport Incubator is tended for use in the electromagnetic environment specified below. The customer or the user of the model TI-2000 Transport Incubator should assure that is used in such an environment.		
Emission test	Compliance level	Electromagnetic environment-guidance
RF emissions CISPR 11	Group 1	The model TI-2000 Transport Incubator uses RF energy only for its internal function. Therefore, its RF emissions are very low and aren't likely to cause any interference in nearby electronic equipment.
RF emissions CISPR 11	Class B	The model TI-2000 Transport Incubator is suitable for use in all establishments, including domestic establishments and those directly connected to the public low-voltage power supply network that supplies buildings used for domestic purposes.
Harmonic emission IEC 61000-3-2	Class A	
Voltage fluctuations/ flicker emissions IEC 61000-3-3	Complies	

### Recommended separation distances between portable and mobile RF communications equipment and the EQUIPMENT or SYSTEM

Recommended separation distances between portable and mobile RF communications equipment and the TI-2000 Transport Incubator			
The TI-2000 Transport Incubator is intended for use in an electromagnetic environment in which radiated RF disturbances are controlled. The customer or the user of the TI-2000 Transport Incubator can help prevent electromagnetic interference by maintaining a minimum distance between portable and mobile RF communications equipment (transmitters) and the TI-2000 Transport Incubator as recommended below, according to the maximum output power of the communications equipment.			
Rated maximum output power of transmitter (W)	Separation distance according to frequency of transmitter (m)		
	150kHz to 80MHz	80MHz to 800MHz	800MHz to 2.5GHz
	$d = \left[ \frac{3.5}{V_1} \right] \sqrt{P}$	$d = \left[ \frac{3.5}{E_1} \right] \sqrt{P}$	$d = \left[ \frac{7}{E_1} \right] \sqrt{P}$
0.01	0.117	0.117	0.233
0.1	0.369	0.369	0.738
1	1.167	1.167	2.333
10	3.689	3.689	7.379
100	11.667	11.667	23.333
For transmitters rated at a maximum output power not listed above, the recommended separation distance d in metres (m) can be estimated using the equation applicable to the frequency of the transmitter, where P is the maximum output power rating of the transmitter in watts (W) according to the transmitter manufacturer.			
NOTE 1 At 80 MHz and 800 MHz, the separation distance for the higher frequency range applies.			
NOTE 2 These guidelines may not apply in all situations. Electromagnetic propagation is affected by absorption and reflection from structures, objects and people.			

## Guidance and declaration-electromagnetic immunity

Guidance and declaration-electromagnetic immunity			
The model TI-2000 Transport Incubator is tended for use in the electromagnetic environment specified below. The customer or the user of the model TI-2000 Transport Incubator should assure that is used in such an environment.			
Immunity test	IEC60601 test level	Compliance level	Electromagnetic environment-guidance
			<p>Portable and mobile RF communications equipment should be used no closer to any part of the model TI-2000 Transport Incubator, including cables, than the recommended separation distance calculated from the equation applicable to the frequency of the transmitter</p> <p><b>Recommended separation distance</b></p>
Conducted RF IEC 61000-4-6	3V rms 150KHz-80MHz	3V rms	$d = \left[ \frac{3.5}{V_1} \right] \sqrt{P}$
Radiated RF IEC 61000-4-3	3V/m 80MHz-2.5GHz	3V/m	$d = \left[ \frac{3.5}{E_1} \right] \sqrt{P} \quad 80\text{MHz to } 800\text{MHz}$ $d = \left[ \frac{7}{E_1} \right] \sqrt{P} \quad 800\text{MHz to } 2.5\text{GHz}$
			<p>Where P is the maximum output power rating of the transmitter in watts (W) according to the transmitter manufacturer and d is the recommended separation distance in meters (m).</p> <p>Field strength from fixed RF transmitters, as determined by an electromagnetic site survey <sup>a</sup>, should be less than the compliance level in each frequency range <sup>b</sup>.</p> <p>Interference may occur in the vicinity of equipment marked with the following symbol:</p> <div style="text-align: center;">  </div>
<p>Note 1 At 80MHz and 800MHz, the higher frequency range applies.</p> <p>Note 2 These guidelines may not apply in all situations. Electromagnetic propagation is affected by absorption and reflection from structures, objects and people.</p>			
<p><sup>a</sup> Field strength from fixed transmitters, such as base stations for radio telephones and land mobile radios, amateur radio, AM and FM radio broadcast and TV broadcast cannot be predicted theoretically with accuracy. To assess the electromagnetic environment due to fixed RF transmitters, and electromagnetic site survey should be considered. If the measured field strength in the location in which the Model TI-2000 Transport Incubator is used exceeds the applicable RF compliance level above, the Model TI-2000 Transport Incubator should be observed to verify normal operation. If abnormal performance is observed, additional measures may be necessary, such as re-orienting or relocating the Model TI-2000 Transport Incubator.</p> <p><sup>b</sup> Over the frequency range 150KHz to 80MHz, field strength should be less than 3V/m.</p>			

## Guidance and declaration-electromagnetic immunity

Guidance and declaration-electromagnetic immunity			
The model TI-2000 Transport Incubator is tended for use in the electromagnetic environment specified below. The customer or the user of the model TI-2000 Transport Incubator should assure that is used in such an environment.			
Immunity test	IEC 60601 test level	Compliance level	Electromagnetic environment-guidance
Electrostatic discharge (ESD) IEC 61000-4-2	±6kV contact ±8kV air	±6kV contact ±8kV air	Floors should be wood, concrete or ceramic tile. If floor are covered with synthetic material, the relative humidity should be at least 30%
Electrical fast transient/burst IEC 61000-4-4	±2kV for power supply lines ±1kV for input/output lines	±2kV for power supply lines ±1kV for input/output lines	Mains supply quality should be that of a typical commercial or hospital environment.
Surge IEC 61000-4-5	±1kV differential mode ±2kV common mode	±1kV differential mode ±2kV common mode	Mains supply quality should be that a typical commercial or hospital environment.
Voltage dips, short interruptions and voltage variations on power supply input lines IEC 61000-4-11	<5%U (>95% dip in U) for 0.5 cycle 40%U (60% dip in U) for 5 cycle 70%U (30% dip in U) for 25 cycle <5% U (>95% dip in U) for 5s	<5%U (>95% dip in U) for 0.5 cycle 40%U (60% dip in U) for 5 cycle 70%U (30% dip in U) for 25 cycle <5% U (>95% dip in U) for 5s	Mains supply quality should be that a typical commercial or hospital environment.
Power frequency magnetic field IEC 61000-4-8	3A/m	3A/m	Power frequency magnetic fields should be at levels characteristic of a typical location in a typical commercial or hospital environment.
Note U is the a.c. mains voltage prior to application of the test level.			