

**Title 51**  
**PUBLIC HEALTH—SANITARY CODE**  
**Part XIV. Plumbing**

**Chapter 1. Administration**

**Subchapter A. General**

**§101. Title and Adoption of Louisiana State Plumbing Code (LSPC)**  
**[formerly paragraph 14:001]**

A. The Department of Health and Hospitals, Office of Public Health hereby adopts Part XIV (Plumbing) of the Sanitary Code, state of Louisiana (LAC 51:XIV). "Part XIV (Plumbing) of the Sanitary Code, State of Louisiana" may be cited as the "Louisiana State Plumbing Code", hereinafter referred to as "this code" or "this Part". Any reference or citation to the "Louisiana State Plumbing Code" shall likewise be synonymous to any reference or citation to "Part XIV (Plumbing) of the Sanitary Code, State of Louisiana."

AUTHORITY NOTE: The first source of authority for promulgation of the sanitary code is in R.S. 36:258(B), with more particular provisions found in Chapters 1 and 4 of Title 40 of the Louisiana Revised Statutes. This Part is promulgated in accordance with R.S. 40:4(A)(7) and R.S. 40:5(2)(3)(7)(9)(16)(17)(20).

HISTORICAL NOTE: Promulgated by the Department of Health and Hospitals, Office of Public Health, LR 28:1383 (June 2002), amended LR 38:2795 (November 2012).

**§103. Availability**  
**[formerly paragraph 14:002]**

A. Information concerning purchasing copies of this Part (LAC 51:XIV) may be obtained by contacting the Office of the State Register, P.O. Box 94095, Baton Rouge, LA 70804-9095, telephone (225) 342-5015 or fax (225) 342-0284. This Part is available to be viewed electronically on the Office of the State Register's website at: <http://www.doa.louisiana.gov/osr/osr.htm>.

AUTHORITY NOTE: Promulgated in accordance with R.S. 40:4(A)(7) and R.S. 40:5(2)(3)(7)(9)(16)(17)(20).

HISTORICAL NOTE: Promulgated by the Department of Health and Hospitals, Office of Public Health, LR 28:1383 (June 2002), amended LR 38:2795 (November 2012), repromulgated LR 38:3233 (December 2012).

**§105. Effective Date and Edition**  
**[formerly paragraph 14:003]**

A. Other than those specific portions of this Part pertaining to the implementation of Act No. 362 of the 2011 Regular Session, the remainder of this Part shall become effective on February 20, 2013. Furthermore, the year in which this code becomes effective shall be used to indicate the edition; therefore, the rule being published in the November 20, 2012 *Louisiana Register* may be referred to as the Louisiana State Plumbing Code, 2013 Edition.

AUTHORITY NOTE: Promulgated in accordance with R.S. 40:4(A)(7) and R.S. 40:5(2)(3)(7)(9)(16)(17)(20).

HISTORICAL NOTE: Promulgated by the Department of Health and Hospitals, Office of Public Health, LR 28:1383 (June 2002), amended LR 38:2795 (November 2012).

**Subchapter B. Purpose and Scope**

**§107. Purpose**  
**[formerly paragraph 14:004]**

A. The purpose of this Chapter is to provide for the administration and enforcement of this code.

AUTHORITY NOTE: Promulgated in accordance with R.S. 40:4(A)(7) and R.S. 40:5(2)(3)(7)(9)(16)(17)(20).

HISTORICAL NOTE: Promulgated by the Department of Health and Hospitals, Office of Public Health, LR 38:2796 (November 2012).

**§109. Code Remedial**

A. General. This code is hereby declared to be remedial, and shall be construed to secure the beneficial interests and purposes thereof-which are public safety, health and general welfare-by regulating the installation and maintenance of all plumbing.

B. Quality Control. Quality control of materials and workmanship is not within the purview of this code except as it relates to the purpose stated herein.

C. Permitting and Inspection. The inspection or permitting of any building or plan by any jurisdiction, under the requirements of this code shall not be construed in any court as a warranty of the physical condition of such building or the adequacy of such plan. No jurisdiction or any employee thereof shall be liable in tort for damages for any defect or hazardous or illegal condition or inadequacy in such building or plan, nor for any failure of any component of such building, which may occur subsequent to such inspection or permitting.

AUTHORITY NOTE: Promulgated in accordance with R.S. 40:4(A)(7) and R.S. 40:5(2)(3)(7)(9)(16)(17)(20).

HISTORICAL NOTE: Promulgated by the Department of Health and Hospitals, Office of Public Health, LR 38:2796 (November 2012).

**§111. Scope**

A. Applicability. The provisions of this code shall apply to every plumbing installation, including alterations, repairs, replacement, equipment, appliances, fixtures, fittings and appurtenances.

B. Federal and State Authority. The provisions of this code shall not be held to deprive any federal or state agency, or any applicable governing authority having jurisdiction, of any power or authority which it had on the effective date of

the adoption of this code or of any remedy then existing for the enforcement of its orders, nor shall it deprive any individual or corporation of its legal rights provided by law.

C. Appendices. The appendices included in this code are not intended for enforcement unless specifically referenced in the code text, stated in the appendix or specifically included in the adopting ordinance or promulgated regulations.

D. Referenced Standards. Standards referenced in this code shall be considered an integral part of this code without separate adoption. If specific portions of a standard are denoted by code text, only those portions of the standard shall be enforced. Where code provisions conflict with a standard, the code provisions shall be enforced. Permissive and advisory provisions in a standard shall not be construed as mandatory.

E. Maintenance. All plumbing systems, both existing and new, and all parts thereof, shall be maintained in a safe and sanitary condition. All devices or safeguards which are required by this code when constructed, altered, or repaired, shall be maintained in good working order. The owner, or his designated agent, shall be responsible for the maintenance of the plumbing system.

AUTHORITY NOTE: Promulgated in accordance with R.S. 40:4(A)(7) and R.S. 40:5(2)(3)(7)(9)(16)(17)(20).

HISTORICAL NOTE: Promulgated by the Department of Health and Hospitals, Office of Public Health, LR 38:2796 (November 2012).

### §113. Existing Buildings

A. General. Alterations, repairs or rehabilitation work may be made to any existing plumbing installations without requiring the installations to comply with all the requirements of this code provided that the alteration, repair or rehabilitation work conforms to the requirements of this code for new construction. The plumbing official shall determine the extent to which the existing plumbing installation shall be made to conform to the requirements of this code for new construction.

B. Change of Occupancy Classification. If the occupancy classification of an existing building is changed, the plumbing installation shall be made to comply with this code.

C. Substantial Renovation. If substantial renovation of an existing building or facility is done, the plumbing installation shall be made to comply with this Part.

D. Exemptions from Code for Buildings or Facilities which had Either been Previously Permitted, Licensed or Specifically Approved by the State Health Officer. In accord with LAC 51:I.123 and unless otherwise specifically provided hereinafter, when the construction of buildings and facilities which had either been previously permitted, licensed or specifically approved by the state health officer pursuant to Public Health—Sanitary Code (LAC 51) requirements then in effect, upgrading of such buildings and facilities shall not be required except where:

1. substantial renovation of such buildings or facilities is undertaken; or

2. the ownership thereof or the business located therein changes subsequent to the effective date of this code; or,

a. The text, or a portion thereof, contained in Paragraph 2 of this Subsection above, does not apply when any particular provision of this code allows an exception to such requirement (e.g., see §411.A.1.a of this code). The non-applicable text, or portion thereof, of Paragraph 2 of this Subsection above is limited to what is allowed under the specific exception thereto.

3. a serious health threat exists as determined by the state health officer.

AUTHORITY NOTE: Promulgated in accordance with R.S. 40:4(A)(7) and R.S. 40:5(2)(3)(7)(9)(16)(17)(20).

HISTORICAL NOTE: Promulgated by the Department of Health and Hospitals, Office of Public Health, LR 38:2796 (November 2012).

### §115. Special Historic Buildings

A. The provisions of this code relating to the installation, alteration, repair, enlargement, restoration, replacement or relocation of plumbing installations shall not be mandatory for existing buildings or structures identified and classified by the federal, state or local jurisdiction as special historic buildings when such installations are judged by the plumbing official to be safe and in the public interest of health, safety and welfare regarding any proposed installation, alteration, repair, enlargement, restoration, relocation or replacement.

AUTHORITY NOTE: Promulgated in accordance with R.S. 40:4(A)(7) and R.S. 40:5(2)(3)(7)(9)(16)(17)(20).

HISTORICAL NOTE: Promulgated by the Department of Health and Hospitals, Office of Public Health, LR 38:2797 (November 2012).

## Subchapter C. Powers and Duties of the Plumbing Official

### §117. Authority

A. Pursuant to R.S. 40:4.A(7) the state health officer is required to promulgate this code and pursuant to R.S. 40:5(3) the state health officer has the authority to enforce this code. Any enforcement action by the state health officer shall be in accordance with Part I of the Sanitary Code, State of Louisiana (LAC 51:I), and/or applicable state laws.

AUTHORITY NOTE: Promulgated in accordance with R.S. 40:4(A)(7) and R.S. 40:5(2)(3)(7)(9)(16)(17)(20).

HISTORICAL NOTE: Promulgated by the Department of Health and Hospitals, Office of Public Health, LR 38:2797 (November 2012).

### §119. Right of Entry

A. Whenever necessary to make an inspection to enforce any of the provisions of this code, or whenever the plumbing official has reasonable cause to believe that there exists in any building or upon any premises any condition or code

violation which makes such building or premises unsafe, dangerous or hazardous, the plumbing official may enter such building or premises at all reasonable times to inspect the same or to perform any duty imposed upon the plumbing official by this code, provided that if such building or premises is occupied, he shall first present proper credentials and request entry. If such building or premises is unoccupied, he shall first make a reasonable effort to locate the owner or other persons having charge or control of the building or premises and request entry. If such entry is refused, the plumbing official shall have recourse to every remedy provided by law to secure entry.

B. When the plumbing official shall have first obtained a proper inspection warrant or other remedy provided by law to secure entry, no owner or occupant or any other persons having charge, care or control of any building of premises shall fail or neglect after proper request is made as herein provided, to promptly permit entry therein by the plumbing official for the purpose of inspection and examination pursuant to this code.

AUTHORITY NOTE: Promulgated in accordance with R.S. 40:4(A)(7) and R.S. 40:5(2)(3)(7)(9)(16)(17)(20).

HISTORICAL NOTE: Promulgated by the Department of Health and Hospitals, Office of Public Health, LR 38:2797.

#### **§121. Enforcement**

A. Upon determination that any plumbing system is in violation of, or not in conformity with, the provisions of this code, the plumbing official may initiate enforcement action in accordance with applicable laws, regulations and/or ordinances.

AUTHORITY NOTE: Promulgated in accordance with R.S. 40:4(A)(7) and R.S. 40:5(2)(3)(7)(9)(16)(17)(20).

HISTORICAL NOTE: Promulgated by the Department of Health and Hospitals, Office of Public Health, LR 38:2797 (November 2012).

#### **§123. Revocation of Permits or Approvals**

A. Misrepresentation of Application. The plumbing official may revoke a permit or approval, issued under the provisions of this code, in case there has been any false statement or misrepresentation as to the material fact in the application or plans on which the permit or approval was based.

B. Violation of Code Provisions. The plumbing official may revoke a permit or approval upon determination by the plumbing official that the installation, erection, alteration or repair of the plumbing installation for which the permit or approval was issued is in violation of or not in conformity with, the provisions of this code.

AUTHORITY NOTE: Promulgated in accordance with R.S. 40:4(A)(7) and R.S. 40:5(2)(3)(7)(9)(16)(17)(20).

HISTORICAL NOTE: Promulgated by the Department of Health and Hospitals, Office of Public Health, LR 38:2797 (November 2012).

#### **§125. Unsafe Installations**

A. All plumbing installations regardless of type, which are unsafe or which constitute a hazard to human life, health

or welfare are hereby declared illegal and shall be abated by repair and rehabilitation or by demolition.

AUTHORITY NOTE: Promulgated in accordance with R.S. 40:4(A)(7) and R.S. 40:5(2)(3)(7)(9)(16)(17)(20).

HISTORICAL NOTE: Promulgated by the Department of Health and Hospitals, Office of Public Health, LR 38:2797 (November 2012).

#### **§127. Requirements Not Covered By Code**

A. Any requirements necessary for the strength or stability of an existing or proposed plumbing installation, or for the public safety, health and general welfare, not specifically covered by this code, shall be determined by the plumbing official.

AUTHORITY NOTE: Promulgated in accordance with R.S. 40:4(A)(7) and R.S. 40:5(2)(3)(7)(9)(16)(17)(20).

HISTORICAL NOTE: Promulgated by the Department of Health and Hospitals, Office of Public Health, LR 38:2797 (November 2012).

#### **§129. Alternate Materials and Methods of Construction**

A. The provisions of this code are not intended to prevent the use of any material or method of construction not specifically prescribed by this code, provided any such alternate has been approved by the plumbing official. The plumbing official shall approve any such alternate provided he finds that the alternate for the purpose intended is at least the equivalent of that prescribed in this code in quality, strength, effectiveness, durability and safety. The plumbing official shall require that sufficient evidence or proof be submitted to substantiate any claim made regarding its use.

AUTHORITY NOTE: Promulgated in accordance with R.S. 40:4(A)(7) and R.S. 40:5(2)(3)(7)(9)(16)(17)(20).

HISTORICAL NOTE: Promulgated by the Department of Health and Hospitals, Office of Public Health, LR 38:2797 (November 2012).

#### **§131. Permits**

A. A person, firm or corporation shall not install, enlarge, alter, repair, improve, remove, convert or replace any plumbing work, or cause the same to be done, without first obtaining a plumbing permit (where such permits are required by state, parish, city or other local laws or ordinances) from the plumbing official. Where such permits are not available, the property owner, contractor and installer shall be jointly responsible for the installation being in compliance with the requirements of this code.

AUTHORITY NOTE: Promulgated in accordance with R.S. 40:4(A)(7) and R.S. 40:5(2)(3)(7)(9)(16)(17)(20).

HISTORICAL NOTE: Promulgated by the Department of Health and Hospitals, Office of Public Health, LR 38:2798 (November 2012).

#### **§133. Tests**

A. The plumbing official may require tests or test reports as proof of compliance. Required tests are to be made at the expense of the owner or his agent, by an approved testing laboratory or other approved agency.

AUTHORITY NOTE: Promulgated in accordance with R.S. 40:4(A)(7) and R.S. 40:5(2)(3)(7)(9)(16)(17)(20).

HISTORICAL NOTE: Promulgated by the Department of Health and Hospitals, Office of Public Health, LR 38:2798 (November 2012).

### §135. Variances

A. The plumbing official has the authority and discretion to issue a written variance concerning the application of any provision of this code in any particular case when, in his/her opinion based upon the extenuating circumstances presented, it is determined that the health and safety of the public will not be jeopardized.

NOTE: Refer to §203 of this code for the definition of "plumbing official" and "state health officer". Per these definitions, variances to the requirements of this code may be legally issued only by the state health officer acting personally or by certain individuals that the state health officer personally designates. Once a variance has been issued by the state health officer acting in his capacity as the co-State plumbing official, the co-local plumbing official is not necessarily obliged to agree with the granting of such variance. In accordance with R.S. 40:14, the co-Local plumbing official may decide to deny the request for variance at the local level since local plumbing regulations are allowed to be stricter than state plumbing regulations.

AUTHORITY NOTE: Promulgated in accordance with R.S. 40:4(A)(7) and R.S. 40:5(2)(3)(7)(9)(16)(17)(20).

HISTORICAL NOTE: Promulgated by the Department of Health and Hospitals, Office of Public Health, LR 38:2798 (November 2012).

### §137. Violations and Penalties

A. Any person, firm, corporation or agent; contractor; and/or installer who violates a provision of this code shall be subject to enforcement action by the plumbing official in accordance with applicable laws, regulations and/or ordinances.

AUTHORITY NOTE: Promulgated in accordance with R.S. 40:4(A)(7) and R.S. 40:5(2)(3)(7)(9)(16)(17)(20).

HISTORICAL NOTE: Promulgated by the Department of Health and Hospitals, Office of Public Health, LR 38:2798 (November 2012).

### §139. Severability

A. If any Section, Subsection, Paragraph, Subparagraph, Clause, Subclause, Division, Sentence, or phrase of this Part is for any reason held to be unconstitutional, such decision shall not affect the validity of the remaining portions of this Part.

AUTHORITY NOTE: Promulgated in accordance with R.S. 40:4(A)(7) and R.S. 40:5(2)(3)(7)(9)(16)(17)(20).

HISTORICAL NOTE: Promulgated by the Department of Health and Hospitals, Office of Public Health, LR 38:2798 (November 2012).

## Chapter 2. Definitions

### Subchapter A. General

#### §201. General

A. Scope. For the purpose of this Part, certain abbreviations, terms, phrases, words and their derivatives

shall be construed as set forth in this Chapter or the Chapter to which they are unique.

B. Tense, Gender, and Number. Words used in the present tense include the future. Words in the masculine gender include the feminine and neuter. Words in the feminine and neuter gender include the masculine. The singular number includes the plural and the plural number includes the singular.

C. Words Not Defined. Words not defined herein shall have the meanings stated in the other Chapters of this Part or in other Parts of the Louisiana State Sanitary Code (LAC 51) which are adopted or may be adopted, the codes adopted under the authority of Act 12 of the 2005 First Extraordinary Session, or the American Society of Sanitary Engineering (ASSE) Plumbing Dictionary, Fourth Edition (1988). When words not defined herein are defined in both the Louisiana State Sanitary Code (LAC 51) and in the codes adopted under the authority of Act 12 of the 2005 First Extraordinary Session or in the ASSE's Plumbing Dictionary, Fourth Edition (1988), the definition contained within the Louisiana State Sanitary Code (LAC 51) shall be given preference as it pertains to health and/or health standards. Words not defined in any of these source documents shall have their common usage and meaning as stated in the Merriam-Webster's Collegiate Dictionary-Eleventh Edition, as revised, and other similarly accepted reference texts.

AUTHORITY NOTE: Promulgated in accordance with R.S. 40:4(A)(7) and R.S. 40:5(2)(3)(7)(9)(16)(17)(20).

HISTORICAL NOTE: Promulgated by the Department of Health and Hospitals, Office of Public Health, LR 38:2798 (November 2012).

## Subchapter B. Definition of Terms

### §203. Definition of Terms

Editor's Note: The text in this Section will be effective on January 1, 2013.

A. Unless otherwise specifically provided herein, the following words and terms used in this Part of the Sanitary Code (LAC 51:XIV) are defined for the purposes thereof as follows.

*Access Cover*—a removable plate, usually secured by bolts or screws, to permit access to a pipe or pipe fitting for the purposes of inspection, repair or cleaning.

*Accessible*—having access to but which first may require the removal of a panel, door or similar covering of the item described. See *readily accessible*.

*Administrative Authority*—see *Plumbing Official*.

*Air Break (Drainage System)*—a piping arrangement in which a *drain* from a fixture, device, appliance or apparatus discharges indirectly into a sink or other receptor with the *indirect waste pipe* terminating at a point below the *flood-level rim* of the receiving sink or other receptor. An unobstructed horizontal distance of free atmosphere between the outside of the *indirect waste pipe* and the inside of the receiving sink or other receptor must exist so as to allow a *back-flow* of sewage to spill over the *flood-level rim* of the

receiving sink or other receptor to prevent such *back-flow* from reaching the fixture, device, appliance or apparatus served by the *indirect waste pipe*.

*Air Gap (Drainage System)*—the unobstructed vertical distance through the free atmosphere between the outlet waste pipe and the *flood-level rim* of the receptacle into which it is discharging.

*Air Gap (Water Distribution)*—in a *water supply or distribution system*, the unobstructed vertical distance through the free atmosphere between the lowest opening from any pipe or faucet supplying water to a tank, *plumbing fixture* or other device and the *flood-level rim* of the receptacle.

*Alternate Designed Plumbing System*—a type of *plumbing system* which is not designed in accord with the prescriptive requirements of this code. See Chapter 12 of this Part for special review and approval requirements prior to construction.

*Anchors*—see *supports*.

*And/Or*—in a choice of two code provisions, signifies that use of both provisions will satisfy the code requirement and use of either provision is acceptable also.

*Anti-Scald Valve*—see *scald preventative valve*.

*Appurtenance*—see *plumbing appurtenance*.

*Approved*—approved by the *plumbing official* or other authority having jurisdiction.

*Area Drain*—a receptacle designed to collect surface or rain water from an open area.

*Assembly or Assembly Use*—in the classification of *plumbing fixtures*, *assembly* applies to *fixtures* used by the *public* attending an event at a theatre, auditorium, stadium, arena, gymnasium or similar facility. See the theaters, auditoriums, stadiums, arenas, and gymnasiums occupancy classification listed in Table 411 of this code.

*Automatic Compensating Type Shower Valve*—One of three types of valves that compensate for changes in incoming pressure, temperature, or pressure and temperature. The three types of valves are:

a. *Pressure Balancing Type Shower Valve*—a pressure balancing valve (Type P) which senses incoming hot and cold water pressures and compensates for fluctuations in either hot or cold water to stabilize the outlet temperature.

b. *Thermostatic Type Shower Valve*—a thermostatic balancing valve (Type T) which senses outlet temperature and compensates for fluctuations in either incoming hot and cold water temperatures and/or pressure to stabilize the outlet temperature.

c. *Combination Thermostatic and Pressure Balancing Type Shower Valve*—a combination thermostatic/pressure balancing valve (Type TP) which senses outlet temperature and incoming hot and cold water

pressure and compensates for fluctuations in incoming hot and cold water temperatures and/or pressures to stabilize the outlet temperature.

*Backflow*—the flow of water or other liquids, mixtures, or substances into the distribution pipes of a potable *water supply system* and/or *water distribution system* from any source or sources other than its intended source.

*Backflow Connection*—any arrangement whereby *backflow* can occur.

*Backflow Preventer*—a mechanical device which prevents *backflow* of contaminants and pollutants into the potable water supply or distribution system by means of positive check members in addition to atmospheric ports.

*Backflow Prevention Assembly*—a testable *backflow preventer* which comes assembled from the manufacturer as a complete unit having approved test cocks with shut off valves installed on both the inlet and outlet sides of the *backflow preventer*.

*Back Vent*—see *individual vent*.

*Back Water Valve*—a device (check valve) installed in a *drain* or pit or in the sewer or *drainage system* to prevent *sewage* or drainage from backing into low levels through fixtures or devices not installed sufficiently above sewer or *drainage systems*.

*Battery of Fixtures*—any group of two or more similar adjacent fixtures which discharge into a common horizontal waste or soil branch.

*Battery Venting*—the horizontal wet venting of a number of individual *fixture drains*, connected horizontally to a *branch soil* or *waste pipe* which is circuit or loop vented.

*Beneficial Use*—the technologically feasible uses of *reclaimed water* for domestic, municipal, industrial, agricultural, recreational or therapeutic purposes.

*Boiler Blow Off*—an outlet on a boiler to permit emptying or discharge of sediment.

*Branch*—any part of the piping system other than a *main*, *riser*, or *stack*.

*Branch, Fixture*—see *fixture branch*.

*Branch, Horizontal*—see *horizontal branch*.

*Branch Interval*—a length of soil or waste stack corresponding in general to a story height, but in no case less than 8 feet (ft) (2438 mm), within which the *horizontal branches* from one floor or story of a building are connected to the *stack*.

*Branch Vent*—a vent connecting one or more individual vents with a vent stack or stack vent.

*Building*—any structure built, erected, and framed of component structural parts designed for the housing, shelter, enclosure, or support of persons, animals, or property of any kind.

**Building Drain**—that part of the lowest piping of a *drainage system* which receives the discharge from *soil pipes* and *waste pipes* inside the walls of the *building* and conveys it to the *building sewer* 3 ft (914 mm) outside the *building wall*.

**Building Sewer**—that part of the horizontal piping of a *drainage system* which extends from the ends of the *building drain* and which receives the discharge of the *building drain* and conveys it to:

- a. the lateral or main of a community sewerage system;
- b. the inlet connection of the primary treatment device of either an individual sewerage system or a commercial treatment facility; or,
- c. any other point of sewage disposal.

**Building Storm Drain**—a *building drain* used for conveying rain water, surface water, ground water, subsurface water, condensate, cooling water or other similar discharge to a *building storm sewer*, extending to a point not less than 3 ft (914 mm) outside the building wall.

**Building (House) Storm Sewer**—the extension from the building storm drain to the public storm sewer or other point of disposal.

**Building (House) Subdrain**—that portion of a drainage system which cannot drain by gravity into the building storm sewer.

**Building (House) Trap**—a device, fitting, or assembly of fittings installed in the *building drain* to prevent circulation of air between the *drainage system* of the *building* and the *building sewer*.

**Circuit Vent**—a *branch vent* that serves two or more *traps* and extends from immediately downstream of the uppermost *fixture connection* of a *horizontal branch* to the *vent stack*.

**Code**—generally, refers to Part XIV (Plumbing) of the Sanitary Code, state of Louisiana which may be cited as the “Louisiana State Plumbing Code”, herein referred to as “this code” or “this Part”. Any reference or citation to the Louisiana State Plumbing Code shall likewise be synonymous to any reference or citation to Part XIV (Plumbing) of the Sanitary Code, State of Louisiana. In certain instances, use of this term (*code*) may refer to the entire Louisiana State Sanitary Code (LAC 51) or to certain other Parts of the State Sanitary Code besides Part XIV.

**Combination Fixture**—a fixture combining one sink and tray or a two or three-compartment sink and/or tray in one unit.

**Combination Waste and Vent System**—an alternate designed plumbing system of waste piping embodying the horizontal wet venting of one or more sinks, dishwashers, floor sinks, indirect waste receptors, floor drains, or similar applications where the fixtures are not adjacent to walls or partitions. It consists of an enlarged diameter horizontal waste pipe which has been adequately sized to provide for

the free movement of air above the flow line of the drain to ensure an adequate vent system. In this non-conventional or non-prescriptive plumbing system [which requires special approval from the state health officer prior to construction (see Chapter 12 of this code)], each trap of each plumbing fixture does not contain an individual vent. This system is different from battery venting in that it is not necessarily constrained by all of the limits prescribed under the battery venting requirements.

**Commercial**—more suitable for a business or industrial use rather than a *domestic* use. Floor drains, floor sinks, curbed cleaning facilities (with floor drain), hub drains, and commercial dishwashing machines (used in restaurants, for example) are considered *commercial*.

**Commercial Treatment Facility**—any sewage treatment facility (designed in accordance with LAC 51:XIII.503) which is required by the state health officer whenever the use of an individual sewerage system is unfeasible or not authorized.

**Common Vent**—a vent connecting at the junction of two *fixture drains* and serving as a vent for both fixtures.

**Community Sewerage System**—any sewerage system which serves multiple connections and consists of a collection and/or pumping/transport system and sewage treatment facility.

**Conductor**—see *leader*.

**Continuous Vent**—a vertical vent that is a continuation of the *drain* to which it connects.

**Continuous Waste**—a *drain* from two or three fixtures connected to a single *trap*.

**Critical Level**—the minimum elevation above the *flood-level rim* of the fixture or receptacle served at which a *backflow preventer* device may be installed. The *critical level* marking on a *backflow preventer* device, including but not limited to a *vacuum breaker*, is normally a horizontal line usually stamped on the device by the manufacturer, the location of which has been established by the manufacturer to conform the device to an accepted standard with the goal of having an approved installation of the device to ensure the proper functioning of the device for cross connection control protection purposes. When a *backflow preventer* device does not bear a *critical level* marking, the bottom of the *vacuum breaker*, combination valve or the bottom of any approved *backflow preventer* device shall constitute the *critical level*.

**Cross Connection**—any physical connection or arrangement between two otherwise separate piping systems, one of which contains *potable water* and the other, water of unknown or questionable safety, whereby water may flow from one system to the other, the direction of flow depending on the pressure differential between the two systems. See *backflow* and *back-siphonage*.

**Crown of Trap**—the topmost point of the inside of a *trap's* outlet.

*Dead End*—a branch leading from a soil, waste, or vent pipe, building drain, or building sewer, which is terminated at a developed length of 2 ft (610 mm) or more by means of a plug or other closed fitting.

*Depth of Water Seal*—the depth of water which would have to be removed from a fully charged trap before air could pass through the trap.

*Developed Length*—the length of a pipe along the center line of the pipe and fittings.

*Diameter*—the nominal diameter as designated commercially, unless otherwise stated.

*Domestic*—associated with service to mankind and the activities of his home or private residence, the household, household affairs, the family, guest rooms of hotels and motels, and patient rooms of hospital and nursing homes and guest rooms of similar institutions. Water for and liquid waste from lavatories, water closets, tubs and showers, kitchens, sinks, and home laundries are considered domestic.

*Double Offset*—two changes of direction installed in succession or series in continuous pipe.

*Downspout*—see Leader.

*Drain*—any waste pipe or soil pipe which carries waste water or waterborne wastes in a building drainage system.

*Drainage Piping*—see Drainage System.

*Drainage System*—all the piping within public or private premises, which conveys sewage, rain water, or other liquid wastes to a legal point of disposal, but not including:

- a. the laterals or mains of a community sewerage system;
- b. any individual sewerage system or commercial treatment facility (beginning at the inlet connection of the primary treatment device and any parts downstream); or,
- c. any sewage treatment or disposal plant for any community sewerage system.

*Durham System*—a term used to describe soil or waste pipe systems where all piping is of threaded pipe, tubing, or other such rigid construction, using recessed drainage fittings to correspond to the types of piping.

*Effective Opening*—

- a. the minimum cross-sectional area of the water outlet at the point of water supply discharge or the minimum cross-sectional area of the liquid waste outlet at the point of indirect waste pipe discharge, measured or expressed in terms of:
  - i. diameter of a circle; or,
  - ii. if the outlet is not circular, the diameter of a circle of equivalent cross-sectional area.
- b. This term is applicable to and mainly used when determining the minimum unobstructed vertical distance through the free atmosphere {air gap (water distribution)} required between the water outlet and the flood rim level of

the fixture or receptacle into which it is discharging. This term may also be applicable when determining the minimum unobstructed vertical distance through the free atmosphere {air gap (drainage system)} required between a liquid waste outlet of an indirect waste pipe and the flood rim level of the indirect waste receptor.

*Existing Work*—a plumbing system or any part thereof which has been installed prior to the effective date of this code.

*Fixture*—see Plumbing Fixtures.

*Fixture Branch*—a water supply pipe between the fixture supply and a main.

*Fixture Drain*—the drain from the trap of a fixture to the junction of that drain with any other drain pipe.

*Fixture Supply*—a water supply pipe or flexible connector that connects a fixture to a fixture branch.

*Fixture Tail Piece or Connection*—a pipe or other connection located between a fixture and its trap.

*Fixture Unit*—a quantity in terms of which the load-producing effects on the plumbing system of different kinds of plumbing fixtures are expressed on some arbitrarily chosen scale. The value assigned for a particular plumbing fixture represents the degree to which it is expected to load a plumbing system when it is used at the maximum assumed frequency.

*Fixture Unit Flow Rate*—the total discharge flow in gallons per minute of a single fixture divided by 7.5 (gal/ft<sup>3</sup>) which provides the flow rate of that particular plumbing fixture as a unit of flow. Fixtures are rated as multiples of this unit of flow. (One gallon per minute equals 0.0631 liters per second.)

*Flood-Level Rim*—the top edge of the receptacle from which water overflows.

*Floor Drain*—a plumbing fixture for recess in the floor having a floor level strainer intended for the purposes of the collection and disposal of waste water used in cleaning the floor and for the collection and disposal of accidental spillage to the floor. This definition does not include floor sinks and indirect waste receptors.

*Floor Sink*—a type of indirect waste receptor installed as a floor level sink and designed with a removable basket strainer or beehive strainer for the purpose of receiving the discharge from indirect waste pipes only. This classification does not include floor drains with floor level strainers only but may include 3-inch (76 mm) drains with floor level strainers which incorporate funnel drains as an integral part thereof.

*Flush Tank*—a tank located above or integral with water closets, urinals, or similar fixtures for the purpose of flushing the usable portion of the fixture. Other than normal atmospheric pressure, the water in the tank is not stored under any other external pressure and the water released from the tank is considered a gravity flush.

*Flush Valves*—a device located at the bottom of the *flush tank* for the purpose of flushing water closets and similar *fixtures*.

*Flushometer Tank*—a device integrated within an air accumulation vessel which is designed to discharge a predetermined quantity of water (which has been stored under pressure) to *fixtures* for flushing purposes.

*Flushometer Valve*—a device which discharges a predetermined quantity of water to *fixtures* for flushing purposes and is actuated by direct water line pressure.

*Frostproof Closet*—a hopper that has no water in the bowl and has the *trap* and the control valve for its water supply installed below the frost line.

*Fueling Points*—the number of fueling hoses which may be activated simultaneously while refueling automobiles or other motor vehicles.

*Gang Shower*—two or more showers in a common area within an institutional building.

*Grade<sub>(G)</sub>*—normally, this references the location of some object in relation to either the floor or ground level elevation.

*Grade<sub>(L)</sub>*—level of achievement attained in school.

*Grade<sub>(Q)</sub>*—a classification or standard of quality of some object or material.

*Grade<sub>(S)</sub>*—the vertical slope (or vertical rise or fall) of a line of pipe in reference to a horizontal plane. In drainage, it is usually expressed as the fall in a fraction of an inch per foot length of pipe or by stating the fall as a percentage of the horizontal distance.

*Grease Interceptor*—an *interceptor* of less than 125 gallon capacity which is designed and installed so as to separate and retain grease and which is generally installed indoors entirely above *grade<sub>(G)</sub>*.

*Grease Trap*—an *interceptor* of at least 125 gallon capacity which is designed and installed so as to separate and retain grease and which is generally installed below *grade<sub>(G)</sub>* outdoors with provisions for above *grade<sub>(G)</sub>* accessibility for cleaning purposes.

*Hangers*—see *supports*.

*Horizontal Branch*—a *drain pipe* extending laterally from a soil or waste stack or *building drain*, with or without vertical sections or branches, which receives the discharge from one or more *fixture drains* and conducts it to the soil or waste stack or to the *building drain*.

*Horizontal Pipe*—any pipe or fitting which makes an angle of more than 45 degrees (0.785 rad) with the vertical.

*House Drain*—see *building drain*.

*House Sewer*—see *building sewer*.

*House Trap*—see *building (house) trap*.

*Human Consumption*—the use of water by humans for drinking, cooking, bathing, showering, hand washing, dishwashing, or maintaining oral hygiene.

*Indirect Waste Receptor*—a *plumbing fixture* designed specifically to collect and dispose of *liquid waste* received from an *indirect waste pipe* which is connected to other *plumbing fixtures*, plumbing equipment or appliances which are required to discharge to the *drainage system* through either an *air gap (drainage system)* or *air break (drainage system)*. The following type fixtures fall within the classification of *indirect waste receptors*: *floor sinks*, curbed cleaning facilities with floor drain, and standpipe drains with integral *air gaps (drainage system)* or *air breaks (drainage system)*, and may include others when approved as such by the *plumbing official*.

*Indirect Waste Pipe*—a pipe that does not connect directly with the *drainage system* but conveys *liquid wastes* and then discharges such liquid wastes into an *indirect waste receptor* which is directly connected to the *drainage system*.

*Individual Sewerage System*—any system of piping (excluding the *building drain* and *building sewer*), and/or collection and/or transport system which serves one or more connections, and/or pumping facility, and treatment facility, all located on the property where the *sewage* originates; and which utilizes the *individual sewerage system* technology which is set forth in LAC 51:XIII.Chapter 7.Subchapter B, or a *commercial treatment facility* which is specifically authorized for use by the *state health officer*.

*Individual Vent*—a pipe installed to vent an individual *fixture trap* and which connects with the *vent system* above the *fixture* served or terminates in the open air.

*Industrial Wastes*—*liquid wastes* resulting from the processes employed in industrial establishments and free of fecal matter.

*Insanitary*—as opposed to *sanitary*; deficient in sanitation; unclean to a degree to be injurious to health; careless or dangerous hygienic conditions; contrary to *sanitary* principles.

*Interceptor*—an automatic or manual device designed and installed to separate and retain deleterious, hazardous, detrimental, damaging, or undesirable matter from normal wastes for proper disposal, rendering or recycling, and also permits normal *sewage* and *liquid wastes* to discharge into the disposal terminal by gravity.

*Journeyman Plumber*—a natural *person* who possesses the necessary qualifications and knowledge to install, alter and/or repair *plumbing systems*; is licensed as such by the State Plumbing Board of Louisiana; is supervised by a *master plumber* and is in the employ of an employing entity. [see R.S. 37:1377(B)]

*LAC*—Louisiana Administrative Code.

*Laundry Tray*—typically, a large and deep 1 or 2 compartment sink used to wash and rinse laundry.



*Leader*—the water conductor (downspout) from the roof to the building storm drain or other means of disposal.

*Lead Free*—

a. in general:

i. not containing more than 0.2 percent lead when used with respect to solder and flux; and,

ii. not more than a weighted average of 0.25 percent lead when used with respect to the wetted surfaces of pipes, pipe fittings, plumbing fittings, and fixtures.

b. calculation:

i. The weighted average lead content of a pipe, pipe fitting, plumbing fitting, or fixture shall be calculated by using the following formula:

(a). For each wetted component, the percentage of lead in the component shall be multiplied by the ratio of the wetted surface area of that component to the total wetted surface area of the entire product to arrive at the weighted percentage of lead of the component. The weighted percentage of lead of each wetted component shall be added together, and the sum of these weighted percentages shall constitute the weighted average lead content of the product. The lead content of the material used to produce wetted components shall be used to determine compliance with Clause a.ii. above. For lead content of materials that are provided as a range, the maximum content of the range shall be used.

*Listed*—equipment or materials included in a list published by an approved nationally recognized testing laboratory, inspection agency or other organization concerned with product evaluation that maintains periodic inspection of production of *listed* equipment or materials, and whose listing states either that the equipment or material meets nationally recognized standards or has been tested and found suitable for use in a specified manner. The means for identifying *listed* equipment may vary for each testing laboratory, inspection agency, or other organization concerned with product evaluation, some of which do not recognize equipment as *listed* unless it is also labeled. The *plumbing official* should utilize the system employed by the listing organization to identify a *listed* product.

a. In respect to any solder, flux, pipes, pipe fittings, plumbing fittings, or fixtures which are claimed to be lead free, this defined term (*listed*) shall additionally include the requirement that all such solder, flux, pipes, pipe fittings, plumbing fittings, or fixtures have been certified to be lead free by an independent American National Standards Institute (ANSI)-accredited third party testing laboratory, inspection agency or other organization concerned with product evaluation.

*Liquid Waste*—the discharge from any *fixture*, appliance, or appurtenance, in connection with a *plumbing system* which does not receive fecal matter.

*Load Factor*—the percentage of the total connected *fixture unit* flow rate which is likely to occur at any point in

the *drainage system*. It varies with the type of occupancy, the total flow unit above this point being considered, and with the probability factor of simultaneous use.

*Local Vent*—a *vent pipe* which is independent of and not connected to the normal *sanitary sewer* vent piping system and which also terminates in the outside atmosphere in accord with the requirements of Section 907 of this code. It is in no way interconnected with any other *vent pipe* except that the same type of apparatus may be served by a given vent [e.g., one local vent (properly sized) may serve either multiple indirect waste pipes, multiple bedpan washers, or multiple sterilizer vents serving sterilizing apparatus]. Only one type of apparatus shall be served by a given vent. Connections between local vents and normal sanitary plumbing systems are prohibited.

*Loop Vent*—same as a *circuit vent* except that it loops back and connects with the *stack vent* instead of the *vent stack*.

*Main*—the principal artery of any system of continuous piping, to which branches or laterals may be connected.

*Main Vent*—the principal artery of the venting system, to which the vent branches may be connected.

*Manifold*—a device wherein multiple individual distribution pipes are commonly connected and supplied with water. Each individual distribution pipe may be provided with a secondary shutoff valve. If provided, such secondary shutoff valve is located between the *manifold* and the individual distribution pipe.

*Manifold Individual Distribution Pipe*—the specific *water distribution pipe* which delivers water directly from the *manifold* and which terminates at the individual *fixture* water shutoff valve located on the *fixture* side of the wall. This term does not include the fixture supply line from the *fixture* valve to the water connection on the *fixture* itself.

*Master Plumber*—a natural *person* who possesses the necessary qualifications and knowledge to plan and lay out *plumbing systems*; who supervises *journeyman plumbers* in the installation, alteration and/or repair of *plumbing systems* and who is licensed as such by the State Plumbing Board of Louisiana. [see R.S. 37:1377(A)]

*May*—the word "may" is a permissive term.

*Mop Sink*—see *service sink*.

*Nonpotable Water*—in addition to its ordinary meaning, includes water of questionable potability on the discharge side of a *backflow preventer* used to isolate a portion of a *water distribution system* from the remainder of the *water distribution system* due to *backflow* connections.

*Nuisance*—public *nuisance* as known at common law or in equity jurisprudence; and whatever is dangerous to human life or detrimental to health; whatever building, structure, or premises is not sufficiently ventilated, sewerred, drained, cleaned, or lighted, in reference to its intended or actual use; and whatever renders the air or human food or drink or water supply unwholesome.

*Offset*—a combination of elbows or bends in a line of piping which brings one section of the pipe out of the line but into a line parallel with the other section.

*Permit Holder*—any person required to obtain a permit to do *plumbing* work in accordance with state, parish, city or other local laws or ordinances. (Where such permits are not available, the property owner, contractor and installer shall be jointly responsible for the installation being in compliance with the requirements of this code and, where applicable, may all be considered *permit holders* as the term is used in this code.)

*Person*—a natural person, his heirs, executors, administrators, or assigns; and includes a firm, partnership or corporation, it's or their successors or assigns, the state of Louisiana or any of its political subdivisions, the United States government or any of its political subdivisions and any officer, employee and agent of one of those entities. Singular includes plural; male includes female.

*Pitch*—see *grade*<sub>(S)</sub>.

*Plumbing*—the practice, materials and *fixtures* used in the installation, maintenance, extension and alteration of all piping, *fixtures*, appliances and appurtenances in connection with any of the following: *Sanitary* drainage or storm drainage facilities, the venting system and the *water distribution system*, within or adjacent to any building, structure or conveyance; also the practice and materials used in the installation, maintenance, extension or alteration of medical gas piping, medical vacuum piping, storm water, *liquid waste* or *sewage*, and the *water distribution system* of any premises to their connection with any point of disposal or other acceptable terminal. *Plumbing* does not include the installation, alteration, repair or maintenance of automatic sprinklers and their related appurtenances including standpipes when connected to automatic sprinklers and including the underground or overhead water supply beginning at the outlet of an approved *backflow* prevention device installed under the *plumbing* provisions of this code where water is to be used or is intended for use exclusively for fire protection purposes.

*Plumbing Appurtenance*—manufactured device, or a prefabricated assembly, or an on-the-job assembly of component parts, which is an adjunct to the basic piping system and *plumbing fixtures*. An appurtenance demands no additional water supply, nor does it add any discharge load to a *fixture* or the *drainage system*. It is presumed that it performs some useful function in the operation, maintenance, servicing, economy, or safety of the *plumbing system*.

*Plumbing Fixtures*—are installed receptacles, devices, or appliances which are supplied with water or which receive or discharge liquids or liquid-borne wastes, with or without discharge into the *drainage system* with which they may be directly or indirectly connected.

*Plumbing Inspector*—see *plumbing official*.

*Plumbing Official*—the *state health officer* and any individual official, board, department or agency established

and authorized by a state, parish, city or other political subdivision created by law to administer and enforce the provisions of this code as adopted or amended. (Note: Since two persons/entities comprise the term *Plumbing Official*, for purposes of this code, the *state health officer* is sometimes referred to as the "co-State Plumbing Official" and the local plumbing jurisdiction is sometimes referred to as the "co-Local Plumbing Official".)

*Plumbing System*—includes the water-supply and distribution pipes; *plumbing fixtures* and *traps*; *soil*, *waste* and *vent pipes*; *building drains* and *building sewers* including their respective connections, devices and *appurtenances* within the property lines of the premises; water treating or water using equipment; and medical gas and medical vacuum piping and equipment.

*Potable Water*—water having bacteriological, physical, radiological and chemical qualities that make it safe and suitable for human consumption.

*Pressure*—the normal force exerted by a homogenous liquid or gas, per unit of area, on the wall of the container.

a. *Pressure, Static*—the pressure existing without any flow.

b. *Pressure, Flowing*—the residual *pressure* in the water supply pipe at the faucet or water outlet while the faucet or water outlet is wide open and flowing.

c. *Pressure, Residual*—the *pressure* available at the fixture or water outlet after allowance is made for *pressure* drop due to friction loss, head, meter and other losses in a system during maximum demand periods.

*Private* or *Private Use*—in the classification of *plumbing fixtures*, *private* applies to *fixtures* in residences or apartments and similar installations where the *fixtures* are intended for the use of a family or an individual.

*Public* or *Public Use*—in the classification of *plumbing fixtures*, *public* applies to fixtures in general, toilet rooms of schools, gymnasiums, hotels and motels, airports, bus and railroad stations, office buildings, *public* buildings, stadiums, department and mercantile stores, *public* comfort stations, bars, restaurants, commercial buildings or places to which the *public* is invited or which are frequented by the *public* without special permission or special invitation, and other installations (whether pay or free) where a number of fixtures are installed so that their use is similarly unrestricted.

*Reclaimed Water*—treated wastewater effluent meeting the requirements of the Louisiana Reclaimed Water Law (R.S. 30:2391 et seq.) that is suitable for a direct *beneficial use* or a controlled use and that is therefore considered a valuable resource.

*Readily Accessible*—having direct access without the need of removing any panel, door or similar covering of the item described and without requiring the use of portable ladders, chairs, etc. See *Accessible*.

*Relief Vent*—a vent whose primary function is to provide circulation of air between the *drainage system* and *vent system*.

*Residential Buildings*—buildings in which families or households live and in which cooking and sleeping accommodations are provided for each family or household unit independently, and in which no area within the building is used or occupied for any other purpose except that such buildings may have central washing facilities, as permitted in Chapter 4.

*Return Offset*—a double *offset* installed so as to return the pipe to its original alignment.

*Revent Pipe*—that part of a vent pipe line which connects directly with an individual waste or group of wastes, underneath or in back of the *fixture* and extends either to the *main vent* or *branch vent*. Sometimes called an *individual vent*.

*Riser*—a water supply pipe which extends vertically one full story or more to convey water to *branches* or *fixtures*.

*Roof Drain*—a drain installed to receive water collecting on the surface of a roof and to discharge it into the *leader* (downspout).

*Roughing-In*—the installation of all parts of the *plumbing system* which can be completed prior to the installation of *fixtures*. This includes drainage, water supply, and vent piping, and the necessary *fixture* supports.

*Sand Interceptor*—an *interceptor* used to remove sand from the *liquid waste* stream.

*Sanitary*—for or relating to the preservation or restoration of health; associated with measures or equipment for improving conditions that influence health; free from or effective in preventing or checking an agent injurious to health; a water closet, urinal, or similar equipment fitted with appropriate *plumbing* for the purpose of conducting wastewater to a point of collection and treatment prior to discharge.

*Sanitary Sewage*—see *sewage*.

*Sanitary Sewer*—a pipe which carries *sewage* and excludes storm, surface and ground water.

*Scald-Preventative Valve*—a type of valve placed in a water distribution system which is designed to prevent *persons* from being scalded with hot water when using certain types of plumbing fixtures. The valve uses one of the following technologies in its design:

- a. a pressure balancing valve which senses incoming hot and cold water pressures and compensates for fluctuations in either to stabilize outlet temperature;
- b. a thermostatic valve which senses outlet temperature and compensates for fluctuations in incoming hot and cold water temperatures and pressures to stabilize outlet temperature; or,
- c. a combination thermostatic/pressure balancing valve which senses outlet temperature and incoming hot and

cold water pressures and compensates for fluctuations in incoming hot and cold water temperatures and pressures to stabilize outlet temperature.

*Scupper*—an opening in a wall or parapet that allows water to drain from a roof.

*Separator*—see *interceptor*.

*Septic Tank*—a watertight receptacle which receives the discharge of a building sewer and is designed and constructed so as to separate solids from the liquid, digest organic matter through a period of detention, and allow the liquid effluent to discharge into soil absorption trenches, an oxidation pond, a deep-type sand filter bed, and/or an effluent reduction option outside of the tank, all as approved and permitted by the state health officer under the requirements of Part XIII (Sewage Disposal) of the Louisiana State Sanitary Code (LAC 51:XIII).

*Service Sink (slop/mop sink)*—a deep bowl fixture intended for the filling and emptying of buckets or pails. Generally used for janitorial services.

*Sewage*—any *liquid waste* and/or other waste containing animal or vegetable matter in suspension or solution (and may include liquids containing chemicals in solution), the disposal of which requires a *sewerage system* approved and authorized by the *state health officer*, and may include its conveying liquid and/or other liquid or solid material which may be present therein.

*Sewerage System*—any system of piping (excluding the *building drain* and *building sewer*) and/or collection and/or transport system and/or pumping facility and/or treatment facility, all for the purpose of collecting, transporting, pumping, treating and/or disposing of *sewage*.

*Shall*—mandatory requirements.

*Should*—recommended or advisory procedures or equipment (i.e., not a mandatory requirement).

*Side Vent*—a *vent pipe* connecting to the drain pipe through a fitting at an angle not greater than 45 degrees (0.785 rad) to the vertical.

*Slip Joint*—a mechanical type joint used primarily on *fixture traps*. The joint tightness is obtained by compressing a friction type washer such as rubber, nylon, neoprene, lead or special packing material against the pipe by the tightening of a (slip) nut.

*Slope*—see *grade<sub>(s)</sub>*.

*Slop Sink*—see *service sink*.

*Soil Pipe*—any pipe which conveys the discharge of water closets or *fixtures* having similar functions, with or without the discharge from other *fixtures*, to the *building drain* or *building sewer*.

*Solvent Cement*—an adhesive (solvent) or mixture of adhesives which when applied to the surface of pipe and fittings will soften and fuse the plastic resin or compound of resins. Pipes and fittings are then joined causing the surfaces to unite forming a liquid tight joint.

*Special Waste Pipe*—see Chapter 8 of this code.

*Spill-Proof Vacuum Breaker*—an assembly consisting of one check valve force-loaded closed and an air inlet valve force-loaded open to atmosphere, positioned downstream of the check valve.

*Stack*—the vertical *main* of a system of soil, waste or vent piping.

*Stack Group*—a term applied to the location of *fixtures* in relation to the *stack* so that by means of proper fittings, vents may be reduced to a minimum.

*Stack Vent*—the extension of a soil or waste *stack* above the highest horizontal *drain* connected to the *stack*. Sometimes called *waste vent* or soil vent.

*Stack Venting*—a method of venting *fixtures* on a single *branch interval* through the soil or waste *stack*.

*State Health Officer*—means the legally appointed and/or acting *state health officer* as defined in R.S. 40:2 and includes his/her duly authorized technical representative; however, in the case of variances allowed under Section 105 of this code, this term shall mean the *state health officer* acting personally or any such *person* that the *state health officer* has personally designated to duly sign such variances in his/her behalf.

*Storm Drain*—see *building storm drain*.

*Storm Sewer*—a sewer used for conveying rain water, surface water, condensate, cooling water or similar *liquid wastes*.

*Subsoil Drain*—a *drain* which receives only subsurface or seepage water and conveys it to a place of collection and/or disposal.

*Substantial Renovation*—

a.i. alterations or repairs made within a 12 month period, costing in excess of 50 percent of the then physical value of the existing building; or

ii. alterations or repairs made within a 12 month period, costing in excess of \$15,000; or

iii. alterations or repairs made involving a change in "occupancy classification" or use of the property.

b. The physical value of the building in Clause a.i of this Paragraph may be established by an appraisal not more than three years old, provided that said appraisal was performed by a certified appraiser or by the tax assessor in the parish where the building is located.

c. The cost of alterations or repairs in Clause a.ii or a.iii of this Paragraph may be established by:

i. an estimate signed by a licensed architect or a licensed general contractor; or

ii. by copies of receipts for the actual costs.

d. The text contained in Subparagraphs a.i - c.ii of this Paragraph continues to apply when any particular

portion of this code calls for an additional requirement to the term substantial renovation (e.g., see §411.A.1 of this code).

*Sump*—a tank or pit which receives *sewage* or *liquid waste*, located below the normal *grade(s)* of the gravity system and which must be emptied by mechanical means.

*Supports*—devices used for supporting and securing pipe and *fixtures* to walls, ceilings, floors or structural members.

*This Code*—LAC 51:XIV and synonymous to *this Part*.

*This Part*—LAC 51:XIV and synonymous to *this code*.

*Toe*—the point where the interstate highway's exit/entrance ramp meets the intersecting highway.

*Trailer Trap*—a device, fitting or assembly of fittings installed in the *building sewer* for a *travel trailer* or *mobile/manufactured home* which is used to prevent the circulation of air between the *building sewer* and the *drainage system* of the individual *travel trailer* or *mobile/manufactured home*.

*Trap*—a fitting or device so designed and constructed as to provide, when properly vented, a liquid seal which will prevent the back passage of air without materially affecting the flow of *sewage* or *waste* water through it.

*Trap Primer (drainage type)*—an approved device complying with ASSE 1044 designed to deliver a sufficient amount of wastewater to a seldom used *trap* in order that the *trap seal* may be properly maintained.

*Trap Primer (potable water supply fed type)*—an approved device designed to deliver a sufficient amount of water obtained directly from a potable water pressure pipe to a seldom used *trap* in order that the *trap seal* may be properly maintained.

*Trap Seal*—the maximum vertical depth of liquid that a *trap* will retain, measured between the *trap's* crown weir and the top of the dip of the *trap*.

*Trap Seal Primer Valve*—see *trap primer* (potable water supply fed type).

*Unstable Ground*—earth that does not provide a uniform bearing for the barrel of the sewer pipe between the joints at the bottom of the pipe trench.

*Vacuum Breaker*—a device which prevents *back-siphonage* of water by admitting atmospheric pressure through ports to the discharge side of the device.

*Vent Pipe*—see *vent system*.

*Vent Stack*—a vertical *vent pipe* installed primarily for the purpose of providing circulation of air to and from any part of the *drainage system*.

*Vent System*—a pipe or pipes installed to provide a flow of air to or from a *drainage system* or to provide a circulation of air within such system to protect *trap seals* from siphonage and back pressure.

*Vertical Pipe*—any pipe or fitting which is installed in a vertical position or which makes an angle of not more than 45 degrees (0.785 rad) with the vertical.

*Wash Rack*—a floor or slab area with *floor drain* used for cleaning containers and equipment exposed to organic wastes of food origin.

*Waste*—see liquid waste and industrial wastes.

*Waste Pipe*—a pipe which conveys only *liquid waste*, free of fecal matter.

*Waste Vent*—see *stack vent*.

*Water Distribution Pipe*—the piping within a building or structure which conveys cold or hot water from the *water service pipe* to the *plumbing fixtures* and other water outlets.

*Water Distribution System*—the system of pipes that is installed and maintained by the owner or owners on the premises or private property from the discharge side of the meter, the *water main*, or other approved sources of water supply. This system includes the necessary connecting pipes, fittings, control valves, all *appurtenances* connected thereto, and includes fire protection piping if not installed as a separate system.

*Water Heater*—an appliance for supplying potable hot water for domestic or commercial purposes.

*Water Main*—the principal artery (or arteries) used for the distribution of *potable water* to consumers by a *water supply system*. For publicly-owned water supply systems (e.g., municipal water supply systems), water mains are normally located on public property, in the street, or in an approved dedicated easement.

*Water Outlet*—as used in connection with the *water distribution system*, the discharge opening for the water to:

- a. a fixture;
- b. atmospheric pressure (except into an open tank which is part of the water distribution system);
- c. a boiler or heating system; or,
- d. any water-operated device or equipment, but not a part of the *plumbing system*.

*Water Riser Pipe*—see riser.

*Water Service Pipe*—the pipe from the *water main*, water meter, *water supply system* or other approved source of water supply, to the building or structure served.

*Water Supply System*—the system of pipes or other constructed conveyances, structures and facilities through which water is obtained, treated (if necessary) to make it *potable* and then distributed (with or without charge) for *human consumption* or other use.

*Wet Bar*—a bar within a food service establishment at which patrons may walk up to, order, and receive an alcoholic beverage directly from a bartender.

*Wet Vent*—a vent which receives the discharge from wastes other than water closets.

*Yoke Vent*—a pipe connecting upward from a soil or waste *stack* to a *vent stack* for the purpose of preventing pressure changes in the *stacks*.

AUTHORITY NOTE: Promulgated in accordance with R.S. 40:4(A)(7), R.S. 40:5(2)(3)(7)(9)(16)(17)(20), and R.S. 40:1299.27.1.

HISTORICAL NOTE: Promulgated by the Department of Health and Hospitals, Office of Public Health, LR 38:2798 (November 2012).

## Chapter 3. General Regulations

### §301. General

A. Scope. The provisions of this Chapter shall govern the general regulations not specific to other Chapters.

B. Basic Principles. The basic principles of this Subsection are enunciated below as basic goals in environmental sanitation worthy of accomplishment through properly designed, acceptably installed and adequately maintained plumbing systems. Some of the details of plumbing construction must vary, but the basic sanitary and safety principles are the same. The principles may serve to define the intent of this Part and other applicable Parts of the Louisiana State Sanitary Code (LAC 51).

1. Principle Number 1. Buildings, structures and premises intended for human habitation, occupancy, use of employment, or the preparation or processing of food, drinks or other materials for human consumption shall be provided with an adequate, safe and potable water supply through a safe system of piping to all fixtures, appliances, appurtenances, etc.

2. Principle Number 2. Every building having plumbing fixtures installed and intended for human habitation, occupancy or use on premises abutting on a street, alley or easement in which there is a community sewerage system shall have a separate connection with the sewer main.

3. Principle Number 3. A dwelling type building provided with a drainage system, a community sewerage system connection or an individual sewerage system shall have at least one water closet, one bathtub or shower, one lavatory, one kitchen-type sink and an adequate source of hot water for each family unit to meet minimum basic requirements for health, sanitation and personal hygiene. Water heating facilities shall be accessible for emergency maintenance without entering any individual apartment or living unit, except that water heaters may be located within an apartment or living unit when supplying hot water to that unit only. All other buildings, structures or premises intended for human occupancy or use shall be provided with adequate sanitary facilities as may be required, but not less than one water closet and one lavatory.

4. Principle Number 4. Plumbing fixtures shall be made of smooth nonabsorbent material, shall be free from concealed fouling surfaces, and shall be located in ventilated enclosures.

5. Principle Number 5. Each fixture directly connected to the sanitary drainage system shall be equipped with a water-seal trap.

6. Principle Number 6. No substance which will clog the pipes, produce explosive mixtures, destroy the pipes or their joints or interfere unduly with the sewage disposal process shall be allowed to enter the building drainage system.

7. Principle Number 7. Proper protection shall be provided to prevent contamination of food, water, sterile goods and similar materials by backflow of sewage. When necessary, the fixture, device or appliance should be connected indirectly with the building drainage system.

8. Principle Number 8. No water closet shall be located in a room or compartment which is not properly lighted and ventilated.

9. Principle Number 9. If water closets or other plumbing fixtures are installed in buildings where there is no sewer within a reasonable distance, suitable provision shall be made for disposing of the building sewage by some accepted method of sewage treatment and disposal.

10. Principle Number 10. Where a plumbing drainage system may be subject to backflow of sewage, suitable provisions shall be made to prevent its overflow in the building.

11. Principle Number 11. Plumbing shall be installed with due regard to preservation of the strength of structural members and prevention of damage to walls and other surfaces through fixture usage.

12. Principle Number 12. Sewage or other waste, from a plumbing system, which may be deleterious to surface or subsurface waters shall not be discharged into the ground or into any waterway unless it has first been rendered innocuous through subjection to some acceptable form of treatment.

13. Principle Number 13. Plumbing fixtures, devices, appliances and appurtenances shall be adequately supplied with water in sufficient volume and pressure to enable them to function properly.

14. Principle Number 14. The pipes conveying water to plumbing fixtures, appliances, devices and appurtenances shall be of sufficient size as to supply water at rates that will prevent undue pressure drops at any one fixture, when any other fixture, appliance, device or appurtenance or group is being flushed, operated or used.

15. Principle Number 15. There shall be no direct or indirect cross connections, either existing or potential, between a safe potable water supply and an unsafe, nonpotable supply.

16. Principle Number 16. Adequate protection shall be provided to prevent possible backflow or back-siphonage of an unsafe or potentially hazardous fluid or material into a safe water supply.

17. Principle Number 17. Piping and connections of the plumbing system shall be of durable materials, free from defects in workmanship and materials, and systems shall be designed and constructed to provide adequate service for a reasonable life under stresses imposed by structural loading, temperature variation, vibration and other conditions.

18. Principle Number 18. Devices for heating and storing water shall be designed and installed to prevent all danger from overheating and explosion and to prevent undue flow of hot water or steam into the cold water supply pipes.

19. Principle Number 19. Refrigerators, coolers, receptacles, sterilizers, vats and similar equipment used for storing or holding foods, beverages, sterile goods and water conditioning equipment, etc., shall discharge into the building drainage system through an indirect waste.

20. Principle Number 20. Water closets, bathtubs, showers, urinals and similar fixtures shall be suitably enclosed and screened for privacy.

21. Principle Number 21. Plumbing systems, including fixtures, shall be maintained in sanitary condition and proper working order.

22. Principle Number 22. Sewage and wastes from plumbing and drainage systems shall be adequately treated and disposed of in accordance with the requirements of the plumbing official.

23. Principle Number 23. No potable water, soil or waste pipe shall be installed or permitted outside of a building, or concealed in outside walls or in any place where they may be subjected to freezing temperatures, unless adequate provision is made to protect them from freezing.

C. Repairs and Alterations. In existing buildings or premises in which plumbing installations are to be altered, repaired, or renovated, necessary deviations from the provisions of this Part may be permitted, provided such deviations conform to the intent of this Part and are approved in writing by the plumbing official.

D. Health or Safety. Wherever compliance with all the provisions of this code fails to eliminate or alleviate a nuisance which may involve health or safety hazards, the owner or his agent shall install such additional plumbing or drainage equipment as may be necessary to abate such nuisance.

E. Workmanship. Workmanship shall conform to generally accepted good practice.

F. Rodent-Proofing. All exterior openings provided for the passage of piping shall be properly sealed with snugly fitting collars of metal or other approved rodent-proof material securely fastened into place. (Also, additional/more specific requirements which may be applicable can be found at LAC 51:V.305.F, LAC 51:V.305.J, and LAC 51:V.307.C.)

1. Interior openings through walls, floors, and ceilings shall be rodent-proofed as found necessary by the plumbing official.

G. Used Equipment. It shall be unlawful to install used equipment or material for plumbing installations unless it complies with the minimum standards set forth in this code and is approved by the plumbing official.

H. Condemned Equipment. Any plumbing equipment condemned by the plumbing official because of wear, damage, defects, or sanitary hazards shall not be reused for plumbing purposes.

I. Drainage Below Sewer Level. Drainage piping located below the level of the sewer shall be installed in accordance with Chapter 7 of this code.

J. Connections to Drainage System. All plumbing fixtures, drains, appurtenances and appliances used to receive or discharge liquid wastes or sewage shall be directly connected properly to the drainage system of the building or premises, in accordance with the requirements of this code. This Subsection shall not be construed to prevent indirect waste systems provided for in Chapter 8 of this code.

K. Connections to Water Supply. Every plumbing fixture or device or appliance requiring or using water for its proper operation shall be directly or indirectly connected to the water supply system in accordance with the provisions of this code.

AUTHORITY NOTE: Promulgated in accordance with R.S. 40:4(A)(7) and R.S.40:5(2)(3)(7)(9)(16)(17)(20).

HISTORICAL NOTE: Promulgated by the Department of Health and Hospitals, Office of Public Health, LR 38:2806 (November 2012).

### §303. Materials

Editor's Note: The text in this Section will be effective on January 1, 2013.

A. Minimum Standards. Materials listed in this Section are applicable to more than one Chapter. Material requirements for specific systems and fixtures are noted in the specific Chapters. Materials listed in this code shall conform at least to the standards cited when used in the construction, installation, alteration, or repair of any part of a plumbing and drainage system, except that the plumbing official shall allow the extension, addition, or relocation of existing soil, waste or vent pipes with materials of like grade<sub>(Q)</sub>, as permitted by this code.

B. Use of Materials. Where more than one standard is listed, the material shall conform to at least one of the standards cited opposite it. Its use shall be further governed by the requirements imposed in other chapters of the code. Materials not included in the table shall be used only as provided for in §303.A of this code. Materials shall be free of manufacturing defects or damage, however occasioned, which would, or would tend to, render such materials defective, unsanitary, or otherwise improper to accomplish the purpose of this code.

C. Specifications for Materials. Standard specifications for general materials for plumbing installations are listed in Table 303 of this code, with specific material specifications listed elsewhere in this Part. Products conforming at least to

any one of the specifications listed for a given material shall be considered acceptable.

1. Abbreviations used in Table 303 of this code, and with the specific materials as listed elsewhere in this Part refer to standards or specifications as identified below. Addresses and more information for these organizations are listed in Section 1405 of this code.

*AGA*—American Gas Association.

*AHRI*—Air-Conditioning, Heating, and Refrigeration Institute.

*ANSI*—American National Standards Institute, Inc.

*ARI*—Air Conditioning and Refrigeration Institute (effective January 1, 2008, now AHRI)

*APSP*—Association of Pool and Spa Professionals [formerly, National Pool and Spa Institute (*NSPI*)]

*ASME*—American Society of Mechanical Engineers.

*ASSE*—American Society of Sanitary Engineering.

*ASTM*—American Society for Testing Materials International.

*AWS*—American Welding Society.

*AWWA*—American Water Works Association.

*CDA*—Copper Development Association, Inc.

*CISPI*—Cast Iron Soil Pipe Institute.

*CAN/CSA*—Canadian Standards Association.

*FHA-MPS*—Federal Housing Administration - Minimum Property Standards.

*FMRC*—Factory Mutual Research Corporation (approval standards obtained from FM Approvals, LLC)

*FS*—Federal Specifications

(obtained from the General Services Administration, Federal Supply Service, Specification Section)

*MSS*—Manufacturers Standardization Society of the Valve and Fittings Industry, Inc.

*NFiPA*—National Fire Prevention Association.

*NSF*—NSF International.

*PDI*—Plumbing and Drainage Institute.

*PPFA*—Plastic Pipe & Fittings Association.

*PPI*—Plastics Pipe Institute.

*PS*—Product Standard

(by the United States Department of Commerce and obtained from the Superintendent of Documents, Government Printing Office)

*UL*—Underwriters Laboratories, Inc.

2. ASTM standards are issued under fixed designations; the final number shown in Chapter 14 of this

code indicates the year of original adoption, or in the case of revision, the year of last revision. "T" indicates Tentative. In the "CS" series of standards, also, the final number indicates the year of issue.

Table 303 General Materials	
Materials	Standards
<b>Plastic Materials</b>	
Acrylics	ASTM D 788
Nylon	ASTM D 789
Polytetrafluoroethylene (PTFE)	ASTM D 4894, ASTM D4895
<b>Plastic Cement And Solvents</b>	
ABS-Solvent Cement	ASTM D 2235, Listed
Joints for IPS PVC Pipe Using Solvent Cement	ASTM D 2672
Making Solvent-Cement Joints with Polyvinyl Chloride (PVC) Pipe and Fittings	ASTM D 2855
Primers for use in Solvent Cemented Joints of Polyvinyl Chloride (PVC) Plastic Pipe and Fittings	ASTM F 656
PVC Solvent Cement	ASTM D 2564, Listed
Solvent Cements for Transition Joints Between Acrylonitrile-Butadiene-Styrene (ABS) and Polyvinyl Chloride (PVC) Non-Pressure Piping Components	ASTM D 3138, see §711.D.4 of this code (Note: This is not an all-purpose solvent cement. Only to be utilized for joining a building drain to a building sewer)
Safe Handling of Solvent Cements used for Joining Thermoplastic Pipe and Fittings	ASTM F 402
Solvent Cements for Chlorinated Polyvinyl Chloride (CPVC) Plastic Pipe and Fittings	ASTM F 493
<b>Plastic Pipe Installation</b>	
Electrofusion Joining Polyolefin Pipe and Fittings	ASTM F 1290, see §621.E of this code
Heat Fusion Joining of Polyethylene Pipe and Fittings	ASTM F 2620, see §621.E of this code
Heat Joining Polyolefin Pipe and Fittings	ASTM D 2657
Underground Installation of Flexible Thermoplastic Sewer pipe	ASTM D 2321
Underground Installation of Thermo-Plastic Pressure Piping	ASTM D 2774
<b>Valves</b>	
Pressurized Fixture Flushing Devices (Flushometers)	ASSE 1037
<b>Metal Sheet</b>	
Brass, sheet	ASTM B 248/B 248M
Copper, sheet	ASTM B 152/B 152M
Lead, sheet	FS QQ-L-201F(2)
Steel Sheet, Zinc-Coated Galvanized by the Hot-Dip Process	ASTM A 653/A 653M
<b>Miscellaneous</b>	
Bare Stainless Steel Welding Electrodes and Rods	AWS A 5.9/A 5.9M
Brazing Filler Metal	AWS A 5.8/A 5.8M
Cement Lining	AWWA C 104, ANSI A 21.4
Cleanouts	ASME A 112.36.2M
Coal-Tar Enamel and Tape (Protective Coating)	AWWA C 203
Compression Gaskets for Cast Iron Soil Pipe and Fittings	ASTM C 564, CISPI HSN
Couplings used in Cast Iron Systems	ASTM C 564 (Gasket Material Only), CISPI 310, FMRC 1680, ASTM C 1277

Table 303 General Materials	
Materials	Standards
Drinking Water Treatment Units Health Effects Aesthetic Effects	NSF 53, NSF 42
Fixed Flow Restrictors	ASSE 1034
Flexible Transition Couplings for Underground Piping Systems	ASTM C 1173
Floor and Trench Drains	ASME A 112.6.3
Grooved and Shouldered Type Joints	AWWA C 606
Handheld Showers (Backflow Prevention Devices)	ASSE 1014
Laboratory Faucet Backflow Preventers	ASSE 1035
Liquid and Paste Fluxes for Soldering of Copper and Copper Alloy Tube	ASTM B 813
Load Bearing, Bonded, Waterproof Membranes for Thin-Set Ceramic Tile and Dimension Stone Installation	ANSI A 118.10
Making Copper Soldered Joints	ASTM B 828
Plastic Toilet (Water Closet) Seats	IAPMO Z 124.5
Reverse Osmosis Drinking Water Treatment Systems	NSF 58
Roof, Deck and Balcony Drains	ASME A 112.6.4
Rubber Gaskets for Concrete Pipe and Manholes	ASTM C 443/C 443M
Rubber Rings for Asbestos Cement Pipe	ASTM D 1869, see §313.E of this code
Rubber and Thermoplastic Elastomers, Test Methods	ASTM D 395, ASTM D 412, 711.D
Solder Metal	ASTM B 32
Supports (Floor-Affixed) for Off-the-Floor Plumbing Fixtures for Public Use	ASME A112.6.1M
Supports(Framing-Affixed) for Off-the-Floor Water Closets with Concealed Tanks	ASME A112.6.2
Wall Hydrants, Frost Resistant, Automatic Draining, Anti-Backflow Type	ASSE 1019

D. Identification of Materials. Each length of pipe and each pipe fitting, trap, fixture and device used in a plumbing system shall be marked in accordance with the approved applicable standard to which it is manufactured.

E. Installation of Materials. All materials used shall be installed in strict accordance with the standards under which the materials are accepted and approved, including the appendices which are related to installation. In the absence of such installation procedures, the manufacturer's published procedures or recommendations shall be followed.

F. Water Piping Quality. All potable water pipes, pipe related products and materials that join or seal pipes and pipe related products shall be evaluated and listed as conforming with a national consensus product (or material) standard, ANSI/NSF Standard 61, and NSF/ANSI 372. Any solder or flux used in the installation or repair of any plumbing in a residential or nonresidential facility providing water for human consumption shall be lead free.

1. Exception. The lead free requirement of §303.F of this code above shall not apply to:



a. leaded joints necessary for the repair of existing cast iron pipes;

b. pipes, pipe fittings, plumbing fittings, or fixtures, including backflow preventers, that are used exclusively for nonpotable services such as manufacturing, industrial processing, irrigation, outdoor watering, or any other uses where the water is not anticipated to be used for human consumption; or,

c. toilets, bidets, urinals, fill valves, flushometer valves, tub fillers, shower valves, service saddles, or water distribution main gate valves that are 2 inches in diameter or larger.

G. Special Materials. The following apply to several special materials.

1. Lead. See Table 303 of this code. Sheet lead shall be not less than the following:

a. For safe pans - not less than 4 pounds per square foot (psf) [19.5 kilograms/meter<sup>2</sup> (kg/m<sup>2</sup>)] coated with an asphalt paint or equivalent.

b. For flashings of vent terminals - not less than 3 psf (14.6 kg/m<sup>2</sup>).

c. Lead bends and lead traps shall be not less than 1/8-inch (3.18 mm) wall thickness.

d. Any solder or flux which is used in the installation or repair of any plumbing in a residential or nonresidential facility providing water for human consumption shall be lead free (i.e., shall not contain more than 0.2 percent lead). Any pipe, pipe fitting, plumbing fitting, and fixture which is used in the installation or repair of any plumbing in a residential or nonresidential facility providing water for human consumption shall be lead free (i.e., shall not contain more than a weighted average of 0.25 percent lead when used with respect to the wetted surfaces of pipes, pipe fittings, plumbing fittings, and fixtures.)

i. Exception. The lead free requirement of Subparagraph d of this Paragraph shall not apply to:

(a). leaded joints necessary for the repair of existing cast iron pipes;

(b). pipes, pipe fittings, plumbing fittings, or fixtures, including backflow preventers, that are used exclusively for nonpotable services such as manufacturing, industrial processing, irrigation, outdoor watering, or any other uses where the water is not anticipated to be used for human consumption; or,

(c). toilets, bidets, urinals, fill valves, flushometer valves, tub fillers, shower valves, service saddles, or water distribution main gate valves that are 2 inches in diameter or larger.

2. Copper. See Table 303 of this code. Sheet copper shall be not less than the following:

a. Safe pans - 12 ounces (oz) per square foot (sq ft) (3.7 kg/m<sup>2</sup>).

b. Vent terminal flashings - 8 oz per sq ft (2.4 kg/m<sup>2</sup>).

3. Caulking Ferrules. Caulking ferrules shall be manufactured from bronze, wrought copper, or brass and shall be in accordance with Table 303.G.3 of this code below.

Pipe Size (in)	Inside Diameter (in)	Length (in)	Minimum Weight Each
2	2 ¼	4 ½	1 lb 0 oz
3	3 ¼	4 ½	1 lb 12 oz
4	4 ¼	4 ½	2 lb 8 oz

4. Soldering Bushings. Soldering bushings where permitted shall be of red brass in accordance with Table 303.G.4 of this code below.

Pipe Size (In)	Minimum Weight Each
1 1/4	6 oz
1 1/2	8 oz
2	14 oz
2 1/2	1 lb 6 oz
3	2 lb 0 oz
4	3 lb 8 oz

5. Floor Flanges. The following applies to floor flanges.

a. Floor flanges for water closets or similar fixtures shall be not less than 1/8-inch (3.18 mm) thick for brass, 1/4-inch (6.35 mm) thick and not less than 2-inch (51 mm) caulking depth for cast iron or galvanized malleable iron. Flanges shall be of the approved type. Offset closet flanges shall be prohibited, except by approval of the plumbing official. Closet screws and bolts shall be of brass.

b. Flanges shall be soldered to lead bends, or shall be caulked, soldered or threaded to other metal. Plastic flanges shall be joined to plastic closet bends with the approved solvent cement.

6. Cleanouts. The following applies to cleanouts.

a. Cleanouts shall have plugs of brass and shall conform to ASTM A 74. Cleanouts may also have plugs of approved nylon plastic. Plugs may have raised square or countersunk heads except countersunk head shall be used where raised heads may cause a hazard.

b. Cleanout plugs with borosilicate glass systems shall be of borosilicate glass.

7. Nonmetallic Shower Pans. The following applies to non-metallic shower pans.

a. Plasticized polyvinyl chloride (PVC) sheet shall be a minimum of 0.040 inch (1.02 mm) thick, and shall meet the requirements of ASTM D 4551. Sheets shall be joined by solvent welding in accordance with the manufacturer's published recommendations.

b. Non-plasticized chlorinated polyethylene (CPE) sheet shall be a minimum 0.040 inch (1.02 mm) thick and shall meet the requirements of ASTM D 4068. Sheets shall be joined by solvent welding in accordance with the manufacturer's published recommendations.

c. Load bearing, bonded, waterproof membranes for thin-set ceramic tile and dimension stone installation shall meet the requirements of ANSI A 118.10 and shall be installed in accordance with the manufacturer's published recommendations.

d. All shower pan material shall be permanently marked by the manufacturer so as to enable the inspecting authority to determine the acceptability of the material and its identification according to the code. This marking is to be conveniently readable to the inspector when the material is in its installed position.

H. Limitations of Use of Materials. The following applies to limitations on the use of certain materials.

1. Pressure-rated Plastic Pipe and Fittings for Water Service Pipe. The following applies to pressure-rated plastic pipe and fittings for water service pipe.

a. In Tables 303 and 603 of this code, the 4-digit numbers listed under "Materials" column represent the ASTM identification numbers assigned to these materials by the joint ASTM-NSF-PPI committee to assist in quick, easy identification of the materials. The numbers appear as a part of the marking on the pipe and tubing. These and no others are approved.

b. All plastic pipe and fittings approved in this code shall be properly marked as specified by their respective standards. All material shall be installed in accordance with the applicable ASTM standards. No materials shall be commingled within the same system except those which are specifically approved in writing in the respective standards.

c. Existing metallic water service piping used for electrical grounding shall not be replaced with nonmetallic pipe or tubing until other grounding means are provided which are satisfactory to the proper administrative authority having jurisdiction.

2. Plastic Pipe and Fittings for Drain, Wastes and Vents. The following applies to plastic pipe and fittings for drain, wastes and vents.

a. Installations for plumbing drainage, waste and vents both above and below ground, indirect waste and storm drains shall conform to applicable standards listed in Tables 303 and 703 of this code and in conformity with the combustible materials regulations of plumbing in fire rated assemblies, in concealed spaces, and in plenums as required by the applicable codes adopted under the authority of Act 12 of the 2005 First Extraordinary Session.

b. There shall be no commingling of different materials except through proper adapters. In all cases, approved solvent cement designated for the particular material shall be used.

c. Coextruded pipe with a cellular core and solid wall ABS DWV and PVC DWV plastic pipe shall be IPS Schedule 40 when used for drain, wastes and vents.

3. Stainless Steel Water Tube. Stainless steel water tube and piping shall conform to the standards listed in Table 603 of this code.

4. Plastic Pipe for Drains and Sewers. The following applies to plastic pipe for drains and sewers.

a. Coextruded PVC plastic pipe shall have a pipe stiffness of 25 (PS 25) when used for storm sewers, storm drains, foundation drains, and subsoil drains.

b. Coextruded PVC plastic pipe shall have a pipe stiffness of 50 (PS 50) when used for outside building sewers, storm drains, and storm sewers in accordance with §§705.A, 1101.E, 1103.C and 1103.D of this code.

5. Plastic Piping Components and Related Materials. All plastic plumbing pipes, plastic plumbing piping components and related materials shall be listed as conforming with NSF Standard 14.

AUTHORITY NOTE: Promulgated in accordance with R.S. 40:4(A)(7), R.S. 40:5(2)(3)(7)(9)(16)(17)(20), and R.S. 40:1299.27.1.

HISTORICAL NOTE: Promulgated by the Department of Health and Hospitals, Office of Public Health, LR 38:2807 (November 2012).

### §305. Protection of Pipes

A. Breakage and Corrosion. Pipes passing under or through walls shall be protected from breakage. Pipes passing through concrete or cinder walls and floors or other corrosive material shall be protected against external corrosion by a protective sheathing or wrapping or other means that will withstand any reaction from lime and acid of concrete, cinder or other corrosive material. Sheathing or wrapping shall allow for expansion and contraction of piping to prevent any rubbing action. Minimum wall thickness of material is to be 0.025 inch (0.635 mm).

B. Sleeves. The following applies to sleeves.

1. Annular spaces between sleeves and pipes shall be filled or tightly caulked as approved by the plumbing official.

2. Annular spaces between sleeves and pipes in fire rated assemblies shall be filled or tightly caulked in accordance with the applicable codes adopted under the authority of Act 12 of the 2005 First Extraordinary Session.

C. Pipes through Footings or Foundation Walls. A soil pipe, waste pipe, or building drain that passes under a footing or through a foundation wall shall be provided with a relieving arch, or a pipe sleeve of Schedule 40 pipe shall be built into the masonry wall. Such sleeve shall be two pipe sizes greater than the pipe passing through or as may be approved in writing by the plumbing official.

D. Minimum Depth of Water Piping Outside of Building. Water piping outside the building line shall be installed not less than 12 inches (305 mm) deep.

E. Trench Location. Trenching installed parallel to footings shall not extend below the 45° (0.785 rad) bearing plane of the footing or wall unless approved by the plumbing official.

F. Waterproofing of Openings. Joints at the roof, around vent pipes, shall be made watertight by the use of lead, copper, galvanized steel, aluminum, plastic or other approved flashings or flashing material. Exterior wall openings shall be made watertight.

G. Pipes in Wood Construction. Where cutting, notching, or boring occurs within 1 1/2 inches (38 mm) of the face of wooden joists, rafters, or studs, a protective steel plate 1/16-inch (1.59 mm) thick shall be used to protect the piping. The steel plate shall be the full width of the member and shall extend at least 2 inches (51 mm) on each side of the cut, bore, or notch.

1. Exception. A protective plate is not required for cast iron, galvanized or black steel, and Grade<sub>(Q)</sub> H stainless steel pipe.

AUTHORITY NOTE: Promulgated in accordance with R.S. 40:4(A)(7) and R.S. 40:5(2)(3)(7)(9)(16)(17)(20).

HISTORICAL NOTE: Promulgated by the Department of Health and Hospitals, Office of Public Health, LR 38:2810 (November 2012).

### §307. Trenching, Excavation, and Backfill

A. Support of Piping. Buried piping shall be supported throughout its entire length.

B. Open Trenches. All excavations required to be made for the installation of a building drainage system, or any part thereof within the walls of a building, shall be open trench work and shall be kept open until the piping has been inspected, tested and accepted.

C. Mechanical Excavation. Trenches shall be properly graded and tamped to support the load of the pipe installation.

D. Backfilling. Adequate precaution shall be taken to insure proper compactness of backfill around piping without damage to such piping. See §705.H of this code.

E. Tunneling. Where necessary, pipe may be installed by tunneling, jacking or a combination of both. In such cases, special care shall be exercised to protect the pipe from damage either during installation or from subsequent uneven loading. Where earth tunnels are used, adequate supporting structures shall be provided to prevent future settling or caving. Pipe may be installed in larger conduit which has been jacked through unexcavated portions of the trench.

F. Single Trench Prohibited. Water service pipes or any underground water pipes shall not be run or laid in the same trench as the building sewer or drainage piping, except as provided for in Chapters 6 and 7 of this code.

AUTHORITY NOTE: Promulgated in accordance with R.S. 40:4(A)(7) and R.S. 40:5(2)(3)(7)(9)(16)(17)(20).

HISTORICAL NOTE: Promulgated by the Department of Health and Hospitals, Office of Public Health, LR 38:2811 (November 2012).

### §309. Structural Safety

A. General. In the process of installing or repairing any part of a plumbing and drainage installation, the finished floors, walls, ceilings, tile work or any other part of the building or premises which must be changed or replaced shall be left in a safe structural condition in accordance with the requirements of the applicable codes adopted under the authority of Act 12 of the 2005 First Extraordinary Session.

B. Cutting, Notching and Boring. The following applies to cutting, notching and boring.

1. Notches on the ends of joists shall not exceed one-fourth the depth. Holes bored for pipes or cable shall not be within 2 inches (51 mm) of the top or bottom of the joist, and the diameter of any such hole shall not exceed one-third of the depth of the joist. Notches for pipes in the top or bottom of joists shall not exceed one-sixth of the depth and shall not be located in the middle one-third of the span.

2. In exterior walls and bearing partitions, any wood stud may be cut or notched to a depth not exceeding 25 percent of its width. Cutting or notching of studs to a depth not greater than 40 percent of the width of the stud is permitted in nonbearing partitions supporting no loads other than the weight of the partition.

3. A hole not greater in diameter than 40 percent of the stud width may be bored in any wood stud. Bored holes not greater than 60 percent of the width of the stud are permitted in nonbearing partitions or in any wall where each bored stud is doubled provided not more than two such successive double studs are so bored.

4. In no case shall the edge of the bored hole be nearer than 5/8-inch (15.9 mm) to the edge of the stud. Bored holes shall not be located at the same section of stud as a cut or notch.

AUTHORITY NOTE: Promulgated in accordance with R.S. 40:4(A)(7) and R.S. 40:5(2)(3)(7)(9)(16)(17)(20).

HISTORICAL NOTE: Promulgated by the Department of Health and Hospitals, Office of Public Health, LR 38:2811 (November 2012).

### §311. Fittings

A. Change in Direction. The following applies to the use of fittings in changes of direction of drainage piping.

1. Changes in direction in drainage piping shall be made by the appropriate use of 45° (0.785 rad) wyes, long-or-short-sweep quarter bends, one-sixth, one-eighth, or one-sixteenth bends, or by a combination of these or equivalent fittings. Single and double sanitary tees and quarter bends may be used in drainage lines only where the direction of flow is from the horizontal to the vertical. A sanitary tee shall not be used on a horizontal drainage line as a takeoff fitting for a vent.

2. Changes in direction in Schedule 40 DWV-PVC and ABS drainage piping shall be made by the appropriate use of 45° (0.785 rad) wyes, quarter bends or long sweep quarter bends, one-sixth, one-eighth, or one-sixteenth bends, or by a combination of these or equivalent fittings. Single

and double sanitary tees and quarter bends may be used in drainage lines only where the direction of flow is from the horizontal to the vertical. A sanitary tee shall not be used on a horizontal drainage line as a takeoff fitting for a vent.

B. Short Sweeps. Short sweeps not less than 3-inch diameter may be used in soil and waste lines where the change in direction of flow is from the horizontal to the vertical and may be used for making necessary offsets between the ceiling and the next floor above.

C. Prohibited Fittings. A straight tee branch shall not be used as a drainage fitting. A saddle type fitting or running threads shall not be used in the drainage or vent system. Drainage or vent piping shall not be drilled or tapped unless approved by the plumbing official. A fitting having a hub in the direction opposite to flow shall not be used in the drainage system, unless the pipe is cut by either a saw or snap cutter, which will assure clean, smooth cuts of the pipe. Double sanitary tee pattern fittings shall not receive the discharge of fixtures or appliances with pumping action discharge.

D. Heel or Side Inlet Bend Prohibited. Heel or side inlet quarter bend fittings shall not be used in the drainage or vent system.

F. Obstruction to Flow. A fitting or connection which offers abnormal obstruction to flow shall not be permitted. See §715 of this code.

G. Increasesers and Reducers. Where different sizes of pipes or pipes and fittings are to be connected, the proper size increasesers or reducers or reducing fittings shall be used between the two sizes.

AUTHORITY NOTE: Promulgated in accordance with R.S. 40:4(A)(7) and R.S. 40:5(2)(3)(7)(9)(16)(17)(20).

HISTORICAL NOTE: Promulgated by the Department of Health and Hospitals, Office of Public Health, LR 38:2811 (November 2012).

### §313. Types of Joints

A. Tightness. Joints and connections in the plumbing system shall be gastight and watertight for the pressure required by test, with the exceptions of those portions of perforated or open-joint piping which are installed for the purpose of collecting and conveying ground or seepage water to the underground storm drains.

B. Threaded Joints. Threaded joints shall conform to ASME B 1.20.1. All burrs shall be removed, pipe ends shall be reamed or filed out to size of bore, and all chips shall be removed. Pipe-joint cement and sealing compound shall be used only on male threads and be insoluble and nontoxic. All pipe-joint sealants for use on potable water piping shall be listed and labeled by an approved testing laboratory.

C. Wiped Joints. Joints in lead pipe or fittings, or between lead pipe or fittings and brass or copper pipe, ferrules, solder nipples, or traps, shall be full-wiped joints. Wiped joints shall have an exposed surface on each side of a joint not less than 3/4-inch (19.1 mm) and at least as thick as the material being jointed. Wall or floor flange lead-wiped

joints shall be made by using a lead ring or flange placed behind the joints at wall or floor. Joints between lead pipe and cast iron or steel shall be formed by means of a caulking ferrule, soldering nipple, or bushing.

D. Flexible Couplings. Flexible couplings may be used to join plain ends of similar or dissimilar pipes and the flexible coupling shall consist of an approved gasket that is attached to the pipe with special adjustable stainless steel clamps and bolts (see §711.D of this code). The flexible couplings and the approved gasket shall be oil resistant.

E. Precast Joints. Precast collars shall be formed on the spigot and in the bell of the pipe in advance of use. Materials shall be resistant to acids, alkalies and oils, and precast joints shall conform to the requirements of ASTM C 425, and upon installation shall be tested as provided in this code.

F. Cement Mortar Joints and Connections. The following applies to cement mortar joints and connections.

1. Except for repairs and connections to existing lines constructed with such joints, cement mortar joints are prohibited.

2. Where permitted, cement mortar joints shall be made in the following manner: A layer of jute or hemp shall be inserted into the base of the annular joint space and packed tightly to prevent mortar from entering the interior of the pipe or fitting. Not more than 25 percent of the annular space shall be used for jute or hemp. The remaining space shall be filled in one continuous operation with a thoroughly mixed mortar composed of one part cement and two parts sand, with only sufficient water to make the mixture workable by hand. Additional mortar of the same composition shall then be applied to form a one to one slope with the barrel of the pipe. The bell or hub of the pipe shall be swabbed to remove any mortar or other material which may have found its way into such pipe.

G. Burned Lead Joints. Burned (welded) lead joints shall be lapped and the lead shall be fused together to form a uniform weld at least as thick as the lead being jointed.

H. Joints for Plastic Pipe and Fittings. The following applies to joints for plastic pipe and fittings.

1. ABS and PVC pipe and fittings shall be solvent cemented using the proper cement recommended for the particular materials. All pipe cuts shall be square and both pipe and fittings shall be cleaned of all soil, dirt, oil and grease before applying primer or cement. Solvent joints made for pressure applications shall use primers and cements that are in compliance with the applicable ASTM standards. All solvent joints shall be made in accordance with the applicable ASTM standards and shall be allowed to dry before testing. Should any leak occur on water test, the defective joint shall be replaced. All solvent cements and primers shall comply with requirements of the NSF 14 and shall be labeled to identify the laboratory certifying compliance for the particular cement and primer being used.

2. Plastic pipe and fittings for sewer and water pressure lines may also be joined by use of elastomeric

joints when the respective standards for the materials so specify. Joints shall conform to the standards listed in either Table 603 or Table 703 of this code, as applicable, for elastomeric joints.

I. Grooved or Plain End Mechanical Couplings and Fittings. Grooved or plain end mechanical couplings and fittings may be used. Pipe is to be prepared in accordance with manufacturer's specifications.

J. Water Supply and Distribution Systems. Additional provisions for water supply and distribution systems are located in §§619 and 621 of this code.

K. Sanitary Drainage Systems. Additional provisions for sanitary drainage systems are located in 709.

AUTHORITY NOTE: Promulgated in accordance with R.S. 40:4(A)(7) and R.S. 40:5(2)(3)(7)(9)(16)(17)(20).

HISTORICAL NOTE: Promulgated by the Department of Health and Hospitals, Office of Public Health, LR 38:2812 (November 2012).

### §315. Use of Joints

A. Threaded Pipe to Cast Iron. Joints between steel, brass, or copper pipe, and cast iron pipe shall be either caulked or threaded, formed as provided in §§313.B and 709.B of this code, or shall be formed with approved adapter fittings.

B. Lead to Cast Iron or Steel. Joints between lead and cast iron or steel pipe shall be formed by means of wiped joints and a caulking ferrule, soldering nipple, or bushing as provided in §313.C of this code.

C. Connection of Dissimilar Metals. There shall be no commingling of materials except through the use of proper dielectric fittings that make different kinds of metal pipe compatible.

D. Welding or Brazing. Brazing or welding shall be performed in accordance with requirements of recognized published standards of practice and by licensed or otherwise qualified mechanics. All brazing on medical gas systems shall be performed by certified installers meeting the requirements of ASME Boiler and Pressure Vessel Code, Section IX, Welding and Brazing Qualifications, or AWS B 2.2/B 2.2M, Brazing Procedure and Performance Qualification, as referenced in Chapter 14 of this code.

E. Slip Joints. In drainage piping, slip joints may be used on both sides of the trap and in the trap seal. Slip joints in water piping may be used on the exposed fixture supply only.

F. Expansion Joints. Expansion joints must be accessible and may be used where necessary to provide for expansion and contraction of the pipes.

G. Mechanically Formed Tee Connections. The following applies to mechanically formed tee connections.

1. Mechanically extracted collars shall be formed in a continuous operation consisting of drilling a pilot hole and drawing out the tube surface to form a collar having a height not less than three times the thickness of the tube wall.

2. The branch shall be notched to conform to the inner curve of the run tube and dimpled to insure that penetration of the branch tube into the collar is of sufficient depth for brazing and that the branch tube does not obstruct the flow in the main line tube.

3. All joints shall be brazed in accordance with 621.D. Soft soldered joints shall not be permitted.

AUTHORITY NOTE: Promulgated in accordance with R.S. 40:4(A)(7) and R.S. 40:5(2)(3)(7)(9)(16)(17)(20).

HISTORICAL NOTE: Promulgated by the Department of Health and Hospitals, Office of Public Health, LR 38:2813 (November 2012).

### §317. Anchors, Hangers and Supports

A. General. The following apply to anchors, hangers and supports.

1. Strains and Stresses. Piping in a plumbing system shall be installed without undue strains or stresses and provision shall be made for expansion, contraction, and structural settlement.

2. Material. Anchors, hangers, and supports for pipe shall be of sufficient strength to maintain their proportionate share of the pipe alignment and to prevent sagging. Anchors, hangers or supports shall be of a material which is compatible with the pipe and will not promote galvanic action. Anchors, hangers or supports installed below grade<sup>(g)</sup> which may come into contact with the soil shall be of a material which is compatible with the type of soil to which it is exposed to prevent the weakening of the device over time due to corrosion, etc.

3. Attachment. Anchors, hangers and supports shall be securely attached to the building construction.

B. Vertical Piping. The following applies to the support of pipes installed vertically.

1. Attachment. Vertical piping shall be secured at sufficiently close intervals to keep the pipe in alignment and carry the weight of the pipe and contents.

2. Cast Iron Soil Pipe. Cast iron soil pipe shall be supported at the base and at each story level at intervals not exceeding 15 ft (4572 mm).

3. Threaded Pipe. Threaded pipe shall be supported at the base and at not less than every other story at intervals not exceeding 30 ft (9144 mm).

4. Copper Tube. Copper tube shall be supported at each story for piping 1 1/2 inches and over and at not more than 4 ft (1219 mm) intervals for piping 1 1/4 inches and smaller.

5. Lead Pipe. Lead pipe shall be supported at intervals not exceeding 4 ft (1219 mm).

6. Plastic Pipe. Plastic piping shall be supported at each story for piping 2 inches or over and not more than 4 foot (1219 mm) intervals for piping 1 1/2 inches or under.

7. Borosilicate Glass Pipe. Borosilicate glass pipe shall be supported at every floor for 3-inch, 4-inch and 6-

inch diameter vertical runs and at every other floor for sizes 2 inches and smaller. Padded riser clamps with 1/4-inch (6.35 mm) thick elastomeric padding shall be used, restricting sideward as well as downward movement.

C. Horizontal Piping. The following applies to the support of pipes installed horizontally.

1. Supports. Horizontal piping shall be supported at sufficiently close intervals to keep it in alignment and prevent sagging.

2. Cast Iron Soil Pipe. Cast iron soil pipe shall be supported at not more than 5 ft (1524 mm) intervals on 5 ft (1524 mm) lengths and 10 ft (3048 mm) intervals on 10 ft (3048 mm) lengths. Hangers shall be located as near hubs as possible.

3. Threaded Pipe. Threaded pipe shall be supported at approximate 12 ft (3658 mm) intervals.

4. Copper Tubing. Copper tube shall be supported at approximate 8 ft (2439 mm) intervals for tubing 1-inch and smaller and 10 ft (3048 mm) intervals for tubing 1 1/4 inches and larger.

5. Lead Pipe. Lead pipe shall be supported by strips or otherwise for its entire length.

6. Plastic Pipe. Plastic piping shall be supported at not more than 4 ft (1219 mm) intervals.

7. Borosilicate Glass Pipe. Borosilicate glass pipe shall be supported in horizontal runs every 8 to 10 ft (2438 to 3048 mm), never closer unless there are more than two joints in the 8 to 10 ft (2438 to 3048 mm) section. Padded hangers shall be used, of either the clevis or trapeze type.

D. Repair or Replacement. Piping in concrete or masonry walls or footings shall be placed or installed in chases or recesses which will permit access to the piping for repairs or replacement.

E. Base of Stacks. The following applies to the support and off-loading of the base of soil, waste and vent stacks.

1. Supports. The base of all soil, waste and vent stacks shall be supported to the satisfaction of the plumbing official.

2. Piping Material. Other piping material shall be so anchored as to take the load off the stack at the base.

AUTHORITY NOTE: Promulgated in accordance with R.S. 40:4(A)(7) and R.S. 40:5(2)(3)(7)(9)(16)(17)(20).

HISTORICAL NOTE: Promulgated by the Department of Health and Hospitals, Office of Public Health, LR 38:2813 (November 2012).

### §319. Tests

A. Required Tests. The permit holder shall make the applicable tests prescribed in §§319.B thru 319.E of this Part to assure compliance with the provisions of this code. The permit holder shall give reasonable advance notice to the plumbing official when the plumbing work is ready for tests. The equipment, material, power, and labor necessary for the inspection and test shall be furnished by the permit holder

and he is responsible for assuring that the work will withstand the test pressure prescribed in the following tests. All the piping of the plumbing system shall be tested with either water or air. After the plumbing fixtures have been set and their traps filled with water, the entire drainage system shall be submitted to final tests. The plumbing official may require the removal of any cleanouts to ascertain if the pressure has reached all parts of the system.

B. Drainage and Vent Tests. The following applies to the testing of drainage and vent systems.

1. A water test shall be applied to the drainage system and vent system either in its entirety or in sections. If applied to the entire system, all openings in the piping shall be tightly closed, except the highest opening, and the system shall be filled with water to point of overflow. If the system is tested in sections, each opening shall be tightly plugged except the highest openings of the section under test, and each section shall be filled with water, but no section shall be tested with less than 10 ft head of water [29.9 kilopascal (kPa)]. In testing successive sections at least the upper 10 ft (3048 mm) of the next preceding section shall be tested, so that no joint or pipe in the building (except the uppermost 10 ft (3048 mm) of the system) shall have been submitted to a test of less than a 10 ft head of water (29.9 kPa). The water shall be kept in the system, or in the portion under test, for at least 15 minutes before inspection starts; the system shall then be tight at all points.

2. An air test shall be made by attaching an air compressor or testing apparatus to any suitable opening and, after closing all other inlets and outlets to the system, forcing air into the system until there is a uniform gage pressure of 5 psi (34.5 kPa) or sufficient to balance a column of mercury 10 inches in height (33.8 kPa). This pressure shall be held without introduction of additional air for a period of at least 15 minutes.

a. Exception. Cast iron soil pipe joined with compression gaskets or mechanical couplings shall be tested with 6 psi (41.4 kPa) of air and allowed a 1 psi (6.9 kPa) reduction in pressure or a 2-inch (50.8 mm) drop in the column of mercury in a 15 minute period.

3. The final test of the completed drainage and vent system shall be visual and in sufficient detail to assure that the provisions of this code have been complied with, provided, however, that, for cause, it may be necessary to subject the plumbing to either a smoke or peppermint test. Where the smoke test is preferred, it shall be made by filling all traps with water and then introducing into the entire system a pungent, thick smoke produced by one or more smoke machines. When the smoke appears at stack openings on the roof, they shall be closed and a pressure equivalent to a 1-inch water column [248.8 Pascal (Pa)] shall be maintained for 15 minutes before inspection starts. Where the peppermint test is preferred, 2 oz (59 mL) of oil of peppermint shall be introduced for each stack.

C. Test of Water Distribution System. Upon the rough-in completion of a section of or the entire water distribution system [e.g., before closing the wall in and, for example,

after capping and crimping a copper piping system, after plugging and sealing approved plastic piping such as CPVC, PEX, etc.], it shall be tested and proved tight under a water pressure not less than 200 psi (1379 kPa) for at least 15 minutes. The water used for tests shall be obtained from a potable source of supply.

D. Test of Building Sewer. The following applies to the testing of the building sewer.

1. Gravity sewer tests shall consist of plugging the end of the building sewer at the point of connection with the sewerage system, filling the building sewer with water, testing with not less than a 10 ft (3048 mm) head of water and maintaining such pressure until backfill is completed.

2. Forced sewer tests shall consist of plugging the end of the building sewer at the point of connection with the sewerage system and applying a pressure of 5 psi (34.5 kPa) greater than the pump rating, and maintaining such pressure until backfill is completed.

E. Test of Interior Leaders or Downspouts. Leaders or downspouts and branches within a building shall be tested by water or air in accordance with §319.B.1 or §319.B.2 of this code.

F. Backflow Prevention Devices. Backflow prevention devices shall be tested in accordance with ASSE Series 5000, USC's FCCC & HR's "*Manual of Cross-Connection Control*", or UFL's TREEO's "*Backflow Prevention - Theory and Practice*".

1. The test gauge used in testing backflow prevention devices shall be calibrated at a frequency of at least every 12 months by a factory authorized laboratory to an accuracy of  $\pm 0.2$  pounds per square inch differential (psid) (1.378 kPa) for increasing and decreasing pressure differential pressure readings over the scale of 1.0 psid to 15 psid (6.9 kPa to 103.4 kPa). The gauge shall be tested for accuracy in the vertical position with water and at different inlet pressures.

a. The reference source(s) used to verify accuracy shall have a maximum permissible error of  $\pm 0.05$  psig (0.344 kPa). Such reference source(s) shall have their calibration traceable to the National Institute of Standards and Technology (NIST).

AUTHORITY NOTE: Promulgated in accordance with R.S. 40:4(A)(7) and R.S. 40:5(2)(3)(7)(9)(16)(17)(20).

HISTORICAL NOTE: Promulgated by the Department of Health and Hospitals, Office of Public Health, LR 38:2814 (November 2012).

### §321. Additional General Provisions

A. Additional general provisions are contained in:

1. LAC 51:XIV.Chapter 13, Medical Facilities Plumbing Systems;

2. LAC 51:XIV.Chapter 15, Travel Trailers and Travel Trailer Parks; and,

3. LAC 51:XIV.Chapter 17, Mobile/Manufactured Homes and Mobile/Manufactured Home Parks.

AUTHORITY NOTE: Promulgated in accordance with R.S. 40:4(A)(7) and R.S. 40:5(2)(3)(7)(9)(16)(17)(20).

HISTORICAL NOTE: Promulgated by the Department of Health and Hospitals, Office of Public Health, LR 38:2815 (November 2012).

## Chapter 4. Plumbing Fixtures

### §401. General

A. Scope. The provisions of this Chapter shall govern the materials, design, installation, and quality of plumbing fixtures.

B. Prohibited Fixtures. Pan, valve, plunger, offset, washout, latrine, frostproof and other water closets having an invisible seal or an unventilated space or having walls which are not thoroughly washed at each discharge, and floor type trough urinals shall be prohibited. Any water closet which might permit siphonage of the contents of the bowl back into the tank shall be prohibited (for example, low down tank type water closets, etc.).

C. Concealed Slip-Joint Connections. Fixtures having concealed slip-joint connections shall be provided with an access panel or utility space so arranged as to make the slip connections accessible for inspection and repair.

D. Limited Access to Waste and Overflow Fittings. When access to waste and overflow fittings cannot be provided as required for slip-joints in §401.C of this code above or when bathtubs are set head-to-head, joints complying with §621.B of this code may be used. In such limited access cases, waste and overflow shall be of the straight- through type with overflow connecting to the tee branch which will allow the fixture, drain, and trap to be cleaned without disturbing concealed joints. Connections shall be inspected prior to concealment.

AUTHORITY NOTE: Promulgated in accordance with R.S. 40:4(A)(7) and R.S. 40:5(2)(3)(7)(9)(16)(17)(20).

HISTORICAL NOTE: Promulgated by the Department of Health and Hospitals, Office of Public Health, LR 38:2815.

### §403. Installation

A. Cleaning. Plumbing fixtures shall be installed in a manner to afford easy access for cleaning. Where practical, all pipes from fixtures shall be run to the nearest wall.

B. Joints. Where a fixture comes in contact with a wall or floor, the joint shall be watertight.

C. Wall-Hung Bowls. Wall-hung water closet bowls shall be rigidly supported by a concealed metal supporting member so that no strain is transmitted to the closet connection.

D. Setting. Fixtures shall be set level and in proper alignment with reference to adjacent walls. No water closet or bidet shall be set closer than 15 inches (381 mm) from its center to any side wall or partition nor closer than 30 inches (762 mm) center-to-center with adjacent fixtures. No urinal shall be set closer than 12 inches (305 mm) from its center to any side wall or partition nor closer than 24 inches (610 mm) center-to-center with adjacent urinal fixtures (see §713 of this code). There shall be a minimum of 21 inches (533mm)

of clearance provided between the front of the water closet, lavatory or bidet to any wall, fixture or door.

E. Sanitation. All public toilet room floor surfaces shall be of non-absorbent, impervious material.

AUTHORITY NOTE: Promulgated in accordance with R.S. 40:4(A)(7) and R.S. 40:5(2)(3)(7)(9)(16)(17)(20).

HISTORICAL NOTE: Promulgated by the Department of Health and Hospitals, Office of Public Health, LR 38:2815 (November 2012).

**§405. Location of Fixtures**

A. Ventilation and Lighting. The following applies to the ventilation and lighting requirements where plumbing fixtures are installed.

1. Means of Ventilation. Every restroom, bathroom or water closet combination shall be provided with ventilation by one or more operable windows opening to the outside of the building, by mechanical exhaust or by other means approved by the administrative authority.

a. Window Opening. When an operable window opening to the outside of the building is used for ventilation, an insect mesh screen shall be installed on such opening.

b. Mechanical Exhaust. Public restrooms, bathrooms or water closet combinations shall be provided with ventilation by mechanical exhaust. When separate facilities for employees or staff of food service establishments, markets and retail food stores are provided, such facilities shall also be provided with ventilation by mechanical exhaust.

i. All restrooms, bathrooms and water closet combinations which are ventilated by mechanical exhaust shall have fixed openings from adjacent room or corridors or from other approved sources, large enough to provide a sufficient inflow of air to make exhaust ventilation effective.

ii. Ventilation ducts from restrooms, bathrooms and water closet combinations shall be exhausted to the outside air or be connected into an independent system that exhausts to the outside air.

2. Combustion Chambers. The combustion chambers of all heaters, heating systems and other fired equipment shall be vented to the atmosphere. Other parts of the heating, cooling and ventilating system shall be so designed, built and maintained as to ensure that the pressure in the space from which combustion air is drawn does not become negative with respect to the atmosphere.

3. Illumination Level. Artificial lighting shall be installed in every restroom, bathroom or water closet combination sufficient to provide an illumination level of at least 10 foot-candles, measured 3 feet off of the floor.

4. Enclosures. Where a water closet is completely enclosed in a room or by walls, such enclosure shall be separately ventilated and lighted.

B. Improper Location. Piping, fixtures or equipment shall not be located in such a manner as to interfere with the normal operation of windows, doors or other exit openings.

Toilet rooms for public use shall not open directly into a room for the preparation of food for service to the public.

C. Toilet Facilities for Construction Workers. Toilet facilities, of the type and in the quantity approved by the administrative authority or, in lieu thereof, in accord with the Minimum Requirements for Sanitation in Places of Employment (ANSI Z 4.1), shall be provided and maintained in a sanitary condition for the use of workmen during construction.

AUTHORITY NOTE: Promulgated in accordance with R.S. 40:4(A)(7) and R.S. 40:5(2)(3)(7)(9)(16)(17)(20).

HISTORICAL NOTE: Promulgated by the Department of Health and Hospitals, Office of Public Health, LR 38:2815 (November 2012).

**§407. Materials and Performance Standards**

A. Plumbing fixtures shall be constructed from approved materials, have smooth impervious surfaces, be free from defects and concealed fouling surfaces. Except as permitted elsewhere in this code, plumbing fixtures and appurtenances shall conform to the standards listed in the following Table (LAC 51:XIV.Table 407).

General Fixtures and Accessories	
Materials	Standards
Fixture Fittings	ASME A112.18.1, CSA B125.1
Fixture Fittings, Backflow Protection Devices and Systems	ASME A112.18.3
Fixture Waste Fittings	ASME A112.18.2, CSA B125.2
Flexible Water Connectors (prohibited for use in instances when the supply temperature will exceed 150°F)	ASME A112.18.6, CSA B125.6
Fixtures, Enameled Cast Iron and Steel Plumbing	ASME A112.19.1, CSA B45.2
Fixtures, Non-Vitreous Ceramic (Fireclay)	ASME A112.19.9M
Fixtures, Ceramic Plumbing	ASME A112.19.2, CSA B45.1
Fixtures, Hydraulic Performance for Water Closets and Urinals	ASME A112.19.6
Fixtures, Stainless Steel Plumbing	ASME A112.19.3, CSA B45.4
Fixtures, Porcelain Enameled Formed Steel Plumbing	ASME A112.19.4M
Fixtures, Plumbing (for) Land Use, including Fixtures for Medical and Dental Facilities	FS WW-P-541 E/GEN(1)
Lead, Caulking	FS QQ-L-156
Macerating Toilet Systems	ASME A 112.3.4
Plastic Bathtub and Shower Units	ANSI Z124.1.2
Plastic Lavatories	ANSI Z124.3
Plastic Sinks	IAPMO Z124.6
Plastic Water Closet Bowls and Tanks	ANSI Z124.4
Trim for Water Closet Bowls, Tanks and Urinals	ASME A112.19.5
Vitreous China Nonwater Urinals	ASME A112.19.19
Water Hammer Arresters	ASSE 1010

AUTHORITY NOTE: Promulgated in accordance with R.S. 40:4(A)(7) and R.S. 40:5(2)(3)(7)(9)(16)(17)(20).

HISTORICAL NOTE: Promulgated by the Department of Health and Hospitals, Office of Public Health, LR 38:2816 (November 2012).



**§409. Water Conservation**

A. Plumbing fixtures and plumbing fixture fittings shall conform to the following requirements.

1. New or replacement water closets, urinals, sink faucets, lavatories or shower heads shall not be installed with a flow rate or flush volume in excess of the maximum specified in Table 409 of this code below, when tested in accordance with the provisions of the applicable ASME Standard listed in Table 407 of this code.

Table 409 Maximum Allowable Water Usage For Plumbing Fixtures <sup>1</sup>	
Fixture	Max Usage
Lavatory, private	2.2 gpm at 60 psi
Lavatory, public (metering)	0.26 gallons per metering cycle
Lavatory, public (other than metering)	0.5 gpm at 60 psi
Shower Head/Handheld Shower	2.5 gpm at 60 psi
Sink Faucet	2.2 gpm at 60 psi
Urinals	1.0 gal/flushing cycle
Water Closet	1.6 gal/flushing cycle

**NOTES:**

1. Maximum allowable water usage for plumbing fixtures and fixture fittings not listed in this table should conform to the applicable ANSI or ASME standard listed in Table 407 of this code. Blowout fixtures, vegetable sprayers, clinical sinks, service sinks, hose bibbs and emergency showers sinks shall be exempted from these limitations.

2. Nonwater Urinals. Nonwater urinals shall be listed and comply with the applicable standard(s) referenced in Table 407. Nonwater urinals shall have a barrier liquid sealant to maintain a trap seal. Nonwater urinals shall permit the uninhibited flow of waste through the urinal to the sanitary drainage system. Nonwater urinals shall be cleaned and maintained in accordance with the manufacturer's instructions after installation. Where nonwater urinals are installed they shall have a water distribution line roughed-in above each urinal location to allow for the installation of approved water-use type urinals in the event of a retrofit.

3. Self-closing metering faucets shall be installed on lavatories intended to serve the transient public, such as those in, but not limited to, service stations, train stations, airports, restaurants, and convention halls. Self-closing metering faucets used on lavatories or other hand-washing fixtures shall provide a flow of water for at least 15 seconds without the need to reactivate the faucet. Self-closing faucets which are designed to close immediately upon the release of the handle are prohibited for use on lavatories or other type of hand-washing fixtures.

**AUTHORITY NOTE:** Promulgated in accordance with R.S. 40:4(A)(7) and R.S. 40:5(2)(3)(7)(9)(16)(17)(20).

**HISTORICAL NOTE:** Promulgated by the Department of Health and Hospitals, Office of Public Health, LR 38:2816 (November 2012).

**§411. Minimum Plumbing Fixtures**

A. General. The following general requirements are to be used when applying Table 411 of this Part.

1. Restroom Plumbing Fixtures. Notwithstanding the provisions of LAC 51:I.123.A.2, in new construction, substantial renovation or building additions and in changes of occupancy classification or real property ownership, at least the minimum type(s) of rest room plumbing fixtures provided for in this Section shall be installed, and the minimum number of each type of restroom plumbing fixture shall be in accordance with Table 411 of this Part. The term "substantial renovation" as used in this Paragraph includes, but is not limited to, a renovation/operational change which would trigger the need, pursuant to the requirements of Table 411 of this Part, for additional restroom plumbing fixtures to be installed, even if the occupancy classification itself may not have changed.

a. Exception

i. When only a real property ownership change occurs, restroom plumbing fixture upgrades to meet the minimum plumbing fixture requirements contained in this Section and Table 411 of this Part are not to be blindly enforced if the state health officer/Office of Public Health has assurances that the prior or existing business held a food permit (e.g., grocery store, restaurant, etc.) under LAC 51:XXIII and the prospective new business owner agrees, in writing to the state health officer/Office of Public Health, to operate the business in exactly the same manner as the prior or existing business owner (e.g., parents sell a business to their children who will operate the business in exactly the same manner) and there have been no documented complaints, within the past five years, about:

(a). a lack of toilet room fixtures;

(b). urination in non-restroom fixtures or floor areas within the building; or

(c). urination on the outside of the building or the premises or adjoining lots or areas, etc.

ii. This exception to the normal enforcement procedures (i.e., §411.A.1 of this Code) shall not be applicable when a serious health threat to the public exists.

2. Non-Restroom Plumbing Fixtures. Where the construction of buildings and facilities was approved by the state health officer pursuant to Sanitary Code (LAC 51) requirements then in effect, upgrading of such buildings and facilities to comply with the non-restroom plumbing fixture requirements of Table 411 of this Part shall not be required except where:

a. substantial renovation or building additions are undertaken; or

b. where the occupant or real property ownership thereof or the occupancy classification located therein changes subsequent to the effective date hereof; or

c. where a serious health threat to the public health exists, unless otherwise specifically provided hereinafter.

3. The term "substantial renovation" as used in §411.A.2 of this code includes, but is not limited to, a renovation/operational change which would trigger the need,

PUBLIC HEALTH—SANITARY CODE

pursuant to the requirements of Table 411 of this Part, for additional non-restroom plumbing fixtures to be installed, even if the occupant or the occupancy classification itself may not have changed.

4. Except as may be otherwise specifically noted within Table 411 of this Part, the number of occupants of a building shall be determined by the square feet (sq ft) of usable floor space. In determining the usable floor space, the square foot area of permanent structural building components, food service establishment kitchens, toilet rooms, corridors, stairways, vertical shafts and equipment rooms, when necessary for the operation of building utilities only, may be deducted from the total aggregate floor area. The occupant content and the number of required facilities for occupancies other than listed in Table 411 of this Part shall be determined by the plumbing official. Plumbing facilities in the occupancies or tenancies of similar use may be determined by the plumbing official from Table 411 of this Part.

5. In commercial buildings of multiple tenants, common toilet facilities (separate for males and females) for each floor are acceptable in lieu of separate facilities required by this Section only when the applicable building occupant content has common access from within the building. Central facilities shall be installed such that the path of travel to such facilities shall not exceed a distance of 500 feet. The maximum travel distance to the central toilet facilities shall be measured from the main entrance of any store or tenant space. When tenancies, rental units, etc., are to be provided with separate facilities of a partial nature, such facilities are not deductible from the total common facilities required. Tenancies, rental units or other usable areas within a building when separated from the required toilet facilities by walls or partitions without common access openings (i.e., openings through interior walls or partitions that allow access to the toilet facilities) shall be considered independently from the remainder of the building and shall be provided with separate facilities in accordance with this Chapter regardless of the type of occupancy.

6. In self-storage (mini-warehouse) complexes, facilities shall not be required in each building, but shall be

located at the office or entrance and such that the plumbing official determines the intent of the code is satisfied (see Paragraphs 7 and 8 in §411.A of this Code below).

7. In applying the schedule of facilities recorded in Table 411 of this Part, consideration must be given to the accessibility of the fixtures. Conformity purely on a numerical basis may not result in an installation suitable to the need of the individual establishment. For example, multi-storied buildings shall be provided with toilet facilities on each floor based upon the population of the floor. If building is a multi-purpose facility (i.e., a retail fuel station and a retail store, or a retail fuel station and a retail store and a restaurant, or a retail store and retail fuel station, etc.), the occupancy which requires the largest number of fixtures shall apply.

8. Every building and each subdivision thereof intended for public use shall be provided with facilities in accordance with this Chapter. Required facilities shall be directly accessible to the public through direct openings or corridors from the area or areas they are intended to serve. Access to the required toilet facilities for customers shall not pass through areas designated as for employee use only such as kitchens, food preparation areas, storage rooms, closets or similar spaces. Toilet facilities accessible only to private offices shall not be counted to determine compliance with this Chapter. Required facilities shall be free and designated by legible signs for each sex. Pay facilities may be installed when in excess of the required minimum facilities.

9. The toilet room entry door shall not be lockable by a user of the facilities when such room contains multiple water closets (or water closet and urinal fixtures) and the fixtures provided therein are required to meet the minimum number of plumbing fixtures required in accordance with Table 411 of this Part.

10. The "Persons (total)" column included in the following Table 411 below is based upon a 50 percent male to 50 percent female ratio.

<b>Table 411</b> <b>Minimum Plumbing Fixtures</b> [The figures shown are based upon one fixture being the minimum required for the number of persons indicated or any fraction thereof, i.e., if the calculation yields any fraction (no matter how small), the next whole number greater than the fractional number is the minimum fixture requirement]					
<b>Building or Occupancy<sup>1</sup></b>	<b>Occupant Content<sup>1</sup></b>	<b>Water Closets</b> (Urinals can be substituted for up to half of the required water closets)		<b>Lavatories<sup>2</sup></b>	<b>Bathtubs, Showers and Miscellaneous fixtures</b>
Dwelling or Apt. House	Not Applicable	1 for each dwelling or dwelling unit		1 for each dwelling or dwelling unit	Washing machine connection per unit <sup>3</sup> . Bathtub or shower – one per dwelling or dwelling unit. Kitchen sink – one per dwelling or dwelling unit
Schools: Licensed Pre-School, Day Care or Nursery <sup>21</sup>	Maximum Daily Attendance	Children (total)	Fixtures	To be provided in the same proportions as the number of water closets required	Kitchen: Children (total) 7-15: 3 compartment sink (or approved domestic or
		Age 0-4 years		Kitchen:	
		1-20	1		

**Table 411**  
**Minimum Plumbing Fixtures**  
 [The figures shown are based upon one fixture being the minimum required for the number of persons indicated or any fraction thereof, i.e., if the calculation yields any fraction (no matter how small), the next whole number greater than the fractional number is the minimum fixture requirement]

Building or Occupancy <sup>1</sup>	Occupant Content <sup>1</sup>	Water Closets (Urinals can be substituted for up to half of the required water closets)			Lavatories <sup>2</sup>			Bathtubs, Showers and Miscellaneous fixtures	
		Persons (total)	Male	Female	Persons (total)	Male	Female	Persons	Fixtures
		21-40		2	1 in each food preparation and utensil washing area located to permit convenient use by all food and utensil handlers.			commercial dishwashing machine and a 2 compartment sink) <sup>12</sup>	
		41-80		3				16 - up:	
		For each additional 40 children over 80, add			Caring for Infants:			3 compartment sink (dishwashing machine, if provided, must be a commercial type) <sup>12</sup>	
		Age 5 years and above		1	1 in or adjacent to each diaper changing area but never to be located in a food preparation/storage or utensil washing area.			One laundry tray, service sink, or curbed cleaning facility with floor drain on premises for cleaning of mops/mop water disposal.	
			Male	Female					
		1-40	1	1					
		41-80	1	2					
		81-120	2	3					
		121-160	2	4					
		For each additional 40 females over 160, add		1				Caring for Infants:	
		For each additional 80 males over 160, add		1				One extra laundry tray, service sink, or similar fixture is required to clean and sanitize toilet training potties immediately after each use. Such fixture shall be dedicate solely for this purpose and shall not be in the food preparation/storage, utensil washing, or dining areas.	
Schools: Elementary and Secondary	Maximum Daily Attendance	Persons (total)	Male	Female	Persons (total)	Male	Female	One drinking fountain for each 3 classrooms, but not less than one each floor	
		1-50	2	2	1-120	1	1		
		51-100	3	3	121-240	2	2		
		101-150	4	4	For each additional 120 persons over 240, add				
		151-200	5	5		1	1		
		For each additional 50 persons over 200, add	1	1					
Office <sup>4</sup> and Public Buildings	100 sq ft per person	Persons (total)	Male	Female	Persons (total)	Male	Female	Drinking Fountains Fixtures	
(Applies to educational occupancies above the 12th grade <sub>(L)</sub> )		1-15	1	1	1-15	1	1	1-100	1
		16-35	1	2	16-35	1	2	101-250	2
		36-55	2	2	36-60	2	2	251-500	3
		56-100	2	3	61-125	2	3	No less than one fixture each floor subject to access.	
		101-150	3	4	For each additional 120 persons over 125, add	1	1.5		
		For each additional 100 persons over 150, add	1	1.5					
Common toilet facilities for areas of commercial buildings of multiple tenants <sup>5,6,20</sup>	Use the sq ft per person ratio applicable to the single type occupancy(s) occupying the greatest aggregate	Persons (total)	Male	Female	Persons (total)	Male	Female	Drinking Fountains Fixtures	
(Not applicable to do-it-yourself)		1-50	2	2	1-15	1	1	1-100	1
		51-100	3	3	16-35	1	2	101-250	2
		101-150	4	4	36-60	2	2	251-500	3
		For each additional 100 persons			61-125	2	3	501-1000	4
					For each additional 120 persons over 125,			Not less than one fixture each floor subject to access.	

PUBLIC HEALTH—SANITARY CODE

<b>Table 411</b> <b>Minimum Plumbing Fixtures</b> [The figures shown are based upon one fixture being the minimum required for the number of persons indicated or any fraction thereof, i.e., if the calculation yields any fraction (no matter how small), the next whole number greater than the fractional number is the minimum fixture requirement]										
Building or Occupancy <sup>1</sup>	Occupant Content <sup>1</sup>	Water Closets (Urinals can be substituted for up to half of the required water closets)					Lavatories <sup>2</sup>		Bathtubs, Showers and Miscellaneous fixtures	
		Persons (total)	Male	Female	Persons (total)	Male	Female	Persons	Fixtures	
laundries, beauty shops and similar occupancies where persons must remain to receive personal services)	floor area (Consider separately each floor area of a divided floor)	over 150, add	1	1.5	add	1	1.5			
Retail Stores <sup>4,14,16, 18</sup>	200 sq ft per person	Persons (total)	Male	Female	Persons (total)	Male	Female	Drinking Fountains <sup>18</sup>		
		1-35	1	1	1-35	1	1	1-100	1	
		36-55	1	2	36-55	1	2	101-250	2	
		56-80	2	3	56-80	2	3	251-500	3	
		81-100	2	4	81-100	2	4	501-1000	4	
		101-150	2	5	101-150	2	5			
		For each additional 200 persons over 150, add	1	1.75	For each additional 200 persons over 150, add	1	1.75	Not less than one fixture each floor subject to access.		
					Retail Food Markets that also processes or packages meat or other food items: 1 lavatory in each food processing, packaging, and utensil washing area located to permit convenient use by all food and utensil handlers.			All Retail Food Markets: One laundry tray, service sink, or curbed cleaning facility with floor drain on premises for cleaning of mops/mop water disposal.		
								Retail Food Markets that also processes or packages meat or other food items: 3 compartment sink <sup>12</sup>		
Restaurants/Food Service Establishments <sup>4,11, 16, 17</sup>	30 sq ft per person	Persons (total)	Male	Female	Persons (total)	Male	Female	Drinking Fountains <sup>17</sup>		
		1-50	1	1	1-150	1	1	1-100	1	
		51-100	2	2	151-200	2	2	101-250	2	
		101-200	3	3	201-400	3	3	251-500	3	
		201-300	4	4	For each additional 200 persons over 400, add			Kitchen: 3 compartment sink (dishwashing machine, if provided, must be a commercial type) <sup>12</sup>		
		For each additional 200 persons over 300, add	1	2	For each additional 200 persons over 400, add	1	1	Other Fixtures:		
					Kitchen: 1 lavatory in each food preparation and utensil washing area located to permit convenient use by all food and utensil handlers.			One laundry tray, service sink, or curbed cleaning facility with floor drain on premises for cleaning of mops/mop water disposal.		

**Table 411  
Minimum Plumbing Fixtures**

[The figures shown are based upon one fixture being the minimum required for the number of persons indicated or any fraction thereof, i.e., if the calculation yields any fraction (no matter how small), the next whole number greater than the fractional number is the minimum fixture requirement]

Building or Occupancy <sup>1</sup>	Occupant Content <sup>1</sup>	Water Closets (Urinals can be substituted for up to half of the required water closets)			Lavatories <sup>2</sup>			Bathtubs, Showers and Miscellaneous fixtures	
		Persons (total)	Male	Female	Persons (total)	Male	Female	Persons	Fixtures
Clubs, Lounges, and Restaurants/ Food Service Establishments with Club, or Lounge <sup>11,16,17</sup>	30 sq ft per person	Persons (total)			Persons (total)			Drinking Fountains <sup>17</sup>	
		1-25	1	1	1-150	1	1	1-100	1
		26-50	2	2	151-200	2	2	101-250	2
		51-100	3	3	201-400	3	3	251-500	3
		101-300	4	4				501-1000	4
	For each additional 200 persons over 300, add	1	2	For each additional 200 persons over 400, add	1	1	Bar: 3 compartment sink (dishwashing machine, if provided, must be a commercial type) <sup>12</sup> Other Fixtures: One laundry tray, service sink, or curbed cleaning facility with floor drain on premises for cleaning of mops/mop water disposal.		
				Bar: 1 lavatory in each drink preparation area and utensil washing area located to permit convenient use by all drink and utensil handlers.					
Do it yourself Laundries <sup>4</sup>	50 sq ft per person	Persons (total)			Persons (total)			One drinking fountain and one service sink.	
		1-50	1	1	1-100	1	1		
		51-100	1	2	101-200	2	2		
Beauty Shops, Barber shops, nail Salons, and Tanning Facilities <sup>4</sup>	50 sq ft per person	Persons (total)			Persons (total)			One drinking fountain and one service sink or other utility sink.	
		1-35	1	1	1-75	1	1		
		36-75	1	2					
Heavy manufacturing <sup>7</sup> , warehouses <sup>8</sup> , foundries, and similar establishments <sup>9,10</sup>	Occupant content per shift, substantiated by owner. Also see §411.B.2 of this code	Persons (total)			Persons (total)			One drinking fountain for each 75 persons. One shower for each 15 persons exposed to excessive heat or to skin contamination with poisonous, infectious, or irritating material.	
		1-10	1	1	1-15	1	1		
		11-25	2	1	16-35	2	1		
		26-50	3	1	36-60	3	1		
		51-75	4	1	61-90	4	1		
		76-100	5	1	91-125	5	1		
		For each additional 60 persons over 100, add	1	0.1	For each additional 100 persons over 125, add	1	0.1		
			Where there is exposure to skin contamination with poisonous, infectious, or irritating materials, provide 1 lavatory for each 15 persons.						
Light manufacturing <sup>7</sup> , Light Warehousing <sup>8</sup> , and workshops, etc. <sup>9,10</sup>	Occupant content per shift, substantiated by owner. Also see §411.B.2 of this code	Persons (total)			Persons (total)			One drinking fountain for each 75 persons. One shower for each 15 persons exposed to excessive heat or to skin contamination with poisonous, infectious, or irritating material.	
		1-25	1	1	1-35	1	1		
		26-75	2	2	36-100	2	2		
		76-100	3	3	101-200	3	3		
		For each additional 60 persons over 100, add	1	1	For each additional 100 persons over 200, add	1	1		
					Where there is exposure to skin contamination with poisonous, infectious, or irritating materials, provide 1 lavatory for each 15 persons				

PUBLIC HEALTH—SANITARY CODE

<b>Table 411</b> <b>Minimum Plumbing Fixtures</b> [The figures shown are based upon one fixture being the minimum required for the number of persons indicated or any fraction thereof, i.e., if the calculation yields any fraction (no matter how small), the next whole number greater than the fractional number is the minimum fixture requirement]										
Building or Occupancy <sup>1</sup>	Occupant Content <sup>1</sup>	Water Closets (Urinals can be substituted for up to half of the required water closets)						Lavatories <sup>2</sup>		Bathtubs, Showers and Miscellaneous fixtures
		Persons (total)	Male	Female	Persons (total)	Male	Female			
Dormitories  (For exclusively male or female dorms, the fixtures provided shall be double the amount required for the particular gender in a co-ed dorm)	50 sq ft per person (calculated on sleeping area only)	Persons (total) 1-10 11-30 31-100 For each additional 50 persons over 100, add	Male 1 1 3 1	Female 1 2 4 1	Persons (total) 1-12 13-20 For each additional 30 persons over 20, add	Male 1 2 1	Female 1 2 1	One drinking fountain for each 75 persons. One shower or bathtub for each 8 persons, over 150 persons add 1 shower or bathtub for each additional 20 persons. One laundry tray or washing machine for each 50 persons. Service sinks, 1 for each 100 persons.		
Places of Public Assembly without seats and Waiting Rooms at Transportation Terminals and Stations	70 sq ft per person (calculated from assembly area.) Other areas considered separately (see Office or Public Buildings).	Persons (total) 1-50 51-100 101-200 201-400 For each additional 250 persons over 400, add	Male 2 3 4 5 1	Female 2 3 4 5 2	Persons (total) 1-200 201-400 401-750 Over 750 persons, lavatories for each sex shall be required at a number equal to not less than 1/2 of total of required male water closets and urinals.	Male 1 2 3	Female 1 2 3	Drinking Fountains Persons Fixtures 1-100 1 101-350 2 Over 350 add one fixture for each 400.		
Theaters, Auditoriums, Stadiums <sup>15</sup> , Arenas <sup>15</sup> , and Gymnasiums	Use the number of seats as basis (For pew or bench type seating, each 18 inches of pew or bench shall equate to one person)	Persons (total) 1-50 51-100 101-200 201-400 For each additional 250 persons over 400, add	Male 2 3 4 5 1	Female 2 3 4 5 2	Persons (total) 1-200 201-400 401-750 Over 750 persons, lavatories for each sex shall be required at a number equal to not less than 1/2 of total of required male water closets and urinals.	Male 1 2 3	Female 1 2 3	Drinking Fountains Persons Fixtures 1-100 1 101-350 2 Over 350 add one fixture for each 400.		
Churches, Mosques, Synagogues, Temples, and other places of Worship	Use the number of seats as basis (For pew or bench type seating, each 18 inches of pew or bench shall equate to one person)	Persons (total) 1-70 71-150 151-500 For each additional 500 persons over 500, add	Male 1 2 3 1	Female 1 2 3 1	Persons (total) 1-200 201-400 401-750 Over 750 persons, lavatories for each sex shall be required at a number equal to not less than 1/2 of total of required male water closets and urinals.	Male 1 2 3	Female 1 2 3	Drinking Fountains Persons Fixtures 1-100 1 101-350 2 Over 350 add one fixture for each 400.		
Retail Fuel Stations (Along an Interstate highway when the station property is located within 1/2 mile of the nearest toe <sup>19</sup> of the exit/entrance ramp) <sup>16</sup>	Use the number of Fueling Points <sup>13</sup> as the basis	Fueling Points 1-8 9-12 13 or more	Male 1 2 2	Female 1 2 3	Fueling Points 1-12 13 or more	Male 1 1	Female 1 2	Drinking Fountains Fueling Points Fixtures 1-12 1 13 or more 2		

Drinking Fountains

**Table 411  
Minimum Plumbing Fixtures**

[The figures shown are based upon one fixture being the minimum required for the number of persons indicated or any fraction thereof, i.e., if the calculation yields any fraction (no matter how small), the next whole number greater than the fractional number is the minimum fixture requirement]

Building or Occupancy <sup>1</sup>	Occupant Content <sup>1</sup>	Water Closets (Urinals can be substituted for up to half of the required water closets)			Lavatories <sup>2</sup>			Bathtubs, Showers and Miscellaneous fixtures	
		Fueling Points	Male	Female	Fueling Points	Male	Female	Fueling Points	Fixtures
Retail Fuel Stations not meeting above criteria <sup>16</sup>	Use the number of Fueling Points <sup>13</sup> as the initial basis	1 or more	1	1	1 or more	1	1	1 or more	1
Other Miscellaneous Buildings or Occupancies <sup>22</sup>									

**NOTES:**

1. The occupant content and the number of required facilities for occupancies other than listed shall be determined by the plumbing official. Plumbing facilities in the occupancies or tenancies of similar use may be determined by the plumbing official from this table. See §411.A.4 of this Code.

2. Twenty-four linear inches (610 mm) of wash sink or 18 inches (457 mm) of a circular basin, when provided with water outlets for such space, shall be considered equivalent to one lavatory (see §415.H of this Code). In accordance with LAC 51:XVII.109.B, the minimum number of required public or public use lavatories/hand-washing fixtures shall be located within the toilet room.

3. When central washing facilities are provided in lieu of washing machine connections in each living unit, central facilities shall be located for the building served at the ratio of not less than one washing machine for each 12 living units, but in no case less than two machines for each building of 15 living units or less. See §§415.E.2.b and 415.M.4 of this code.

4. With the exception of retail stores associated with retail fuel stations and/or restaurant/food service establishments associated with retail fuel stations and retail stores that require two or more different food permits (see note #14 below), a single facility consisting of one water closet and one lavatory may be used by both males and females in the following occupancies subject to the building area limitations (see also LAC 51:XXIII.3119):

Occupancy	Total Building Area (sq ft)
Office	1200
Retail Store (within covered mall)	3500
Laundries (Self-Service)	1400
Beauty Shops, Barber Shops, Tanning Facilities, and Nail Salons	900

Occupancy	Usable Floor Space (sq ft)
Restaurant/Food Service Establishment (excluding retail fuel stations)	500
Retail Store (excluding retail fuel stations)	1500*

\*A single facility [normally allowed under Note #4 for a retail store occupancy (excluding retail fuel stations)] does not apply when the conditions of Note #14(a) below exist.

5. Common toilet facilities (separate for males and females) for each floor are acceptable in lieu of separate facilities required by this Section only when the applicable building occupant content has common access from within the building. When tenancies, rental units, etc., are to be provided

with separate facilities of a partial nature, such facilities are not deductible from the total common facilities required. See §411.A.5 of this Code.

6. Applicable to small stand-up restaurants and similar occupancies.

7.(a). Light manufacturing is applicable to those manufacturers manufacturing finished products which require no special equipment to handle single finished products but may require special equipment to handle the products when packaged in containers containing multiple products,

(b). Heavy manufacturing is applicable to those manufacturing processes requiring overhead cranes or similar equipment for the movement of raw materials and/or the finished products.

8.(a). Light Storage: Light storage is the storage of items which can be handled without the aid of special handling equipment such as cranes, forklifts or similar equipment,

(b). Heavy Storage: Heavy storage is the storage of items which require special equipment for handling such as cranes, forklifts or similar equipment.

9. For other than industrial areas of the occupancy, see other applicable type occupancies (applicable to facilities provided due to inaccessibility of those in main or initial occupancy).

10. As required by the Minimum Requirements for Sanitation in Places of Employment (ANSI Z 4.1). See §405.C of this Code.

11. If alcoholic beverages are to be served, facilities shall be as required for clubs or lounges; however, this requirement shall not be construed to require a restaurant/food service establishment which serves alcoholic beverages and consists of 500 square feet or less of usable floor space to add any more toilet rooms than the minimum required pursuant to Note #4 above (as long as such small restaurant/food service establishment does not have a wet bar and thus would not fall under the "Club, Lounge, and Restaurants/Food Service Establishments with Club, or Lounge" occupancy classification). See LAC 51:XXIII.3119.

12. At the discretion of the plumbing official, one properly sized grease trap for wastewater from the kitchen utensil washing sink(s), dishwashing machine(s), etc., is also required. See §1005.D of this Code.

13. Fueling point means the number of fueling hoses which may be activated simultaneously while refueling automobiles or other motor vehicles. See §203—*Fueling Point* definition of this Code.

14.(a). A retail store which requires two or more different food permits (e.g., grocery permit, restaurant permit, etc.) under LAC 51:XXIII and has a combined usable floor space of more than 500 square feet shall be required to provide no less than a minimum of two facilities consisting of one water closet and one lavatory each. See LAC 51:XXIII.3119.

(b). A retail store which requires two or more different food permits under LAC 51:XXIII and has a

combined usable floor space of 500 square feet or less shall be allowed to operate with a single facility consisting of one water closet and one lavatory used by both males and females. The allowance to operate with a single facility assumes that a wet bar is not located on the premises. See LAC 51:XXIII.3119.

15.(a). Trough urinals may only be used for stadiums, arenas, and jails, prisons, or other institutions of detention or incarceration. Trough urinals, when used, shall conform to the following requirements: They shall not be less than 6 inches deep and shall be furnished with one piece backs and have strainers with outlets at least 1 1/2 inches in diameter. The washdown pipe shall be perforated so as to flush with an even curtain of water against the back of the urinal. This pipe shall be securely clamped as high as practicable to the back of the urinal. Trough urinals, where so equipped, shall have tanks with a flushing capacity of not less than 1 1/2 gallons of water for each 2 feet of urinal length (see §415.L.4 of this Code).

(b). Trough urinals shall be figured on the basis of one urinal for each 18 inches of length, provided that: 24-inch urinal equals 1 urinal; 36-inch urinal equals 2 urinals; 48-inch urinal equals 2 urinals; 60-inch urinal equals 3 urinals; and a 72-inch urinal equals 4 urinals (see §415.L.4 of this Code).

(c). Privacy screens shall not be required for trough urinals. See §415.L.5.c.i.(a) of this Code.

16. If building is a multi-purpose facility (i.e., a retail fuel station and a retail store, or a retail fuel station and a retail store and a restaurant, or a retail store and retail fuel station, etc.), the occupancy which requires the largest number of fixtures shall apply. See §411.A.7 of this Code.

17. Drinking fountain requirement may be waived if drinking water is dispensed in an approved, sanitary manner in accord with the requirements of Part XXIII of the Louisiana State Sanitary Code (LAC 51:XXIII). Minimally, such Part XXIII facility shall hold a health permit from DHH-OPH which requires a three compartment sink and a hand wash lavatory in the food preparation area. Any Part XXIII permitted-facility not meeting this requirement [such as grocery store serving pre-packaged food items only (equivalent to a retail store)] shall install a publicly accessible drinking fountain(s). See LAC 51:XXIII.3119.

18. Drinking fountains shall not be required in retail stores with 2,000 square feet or less of usable floor space.

19. "Toe" is defined as the point where the Interstate highway's exit/entrance ramp meets the intersecting highway. See §203 of this Code—Toe definition.

20. Central facilities shall be installed such that the path of travel to such facilities shall not exceed a distance of 500 feet. The maximum travel distance to the central toilet facilities shall be measured from the main entrance of any store or tenant space. See §411.A.5 of this Code.

21. For pre-school children, between the ages of 0-4, fixtures shall be size appropriate for the age of the children being cared for (toilets 11 inches maximum height and lavatories 22 inches maximum height), or if standard size fixtures are used, safe, cleanable step aids shall be provided. See LAC 51:XXI.105.C.5.a.

22. Refer to the following Parts of the Louisiana State Sanitary Code (LAC 51) for specific information relative to the number of plumbing fixtures required for these other miscellaneous buildings or occupancies:

Building or Occupancy	Louisiana State Sanitary Code (LAC 51)
Temporary Food Service (Festivals or Fairs)	Part XXIII, Chapter 47
Swimming Pools	Part XXIV
Mass Gathering Areas	Part XXV

B. Adjustments to Minimum Facilities. When necessary, the following may be utilized to make adjustments to the minimum facilities requirements.

1. The "Persons (total)" column included in Table 411 of this Part is based upon a 50 percent male to 50 percent female ratio. The plumbing official may make adjustments in the distribution of facilities between male and female when furnished satisfactory data to substantiate a claim that the numbers of male and female fixtures in Table 411 of this code would not provide a satisfactory ratio of facilities based on the male-female ratio for the ultimate users. In any case, where deviation is permitted, in accordance with this Section, the plumbing official may require additional facilities if the data submitted proves to be in error or if changes are made that affect such data, whether it be by the original or later owner or occupants of the building or tenancy.

2. The plumbing official may make adjustments in the occupant content established by Table 411 of this code when, in a particular case, satisfactory data, accompanied by plans, is furnished which substantiates a claim that the occupant content of a particular building or tenancy will, at all times, be less than provided for in the above table. Approval of such data and accompanying claims shall not prevent the plumbing official from requiring additional facilities based on the above table, should changes be made affecting the data or plan upon which the original approval was based whether such changes be made by the original or ultimate owner or building occupant or occupants. The remainder of the facilities' requirements of §411 of this code are not affected by this paragraph.

C. Facilities' Separation. The occupant content established by this code shall not be construed to have any force or effect upon the occupant content requirements of the codes adopted under the authority of Act 12 of the 2005 First Extraordinary Session. The occupant content in this code is established only to calculate the number of plumbing facilities required for a building or for a tenancy within a building when such tenancy is separated from the remainder of the building by walls or partitions or when central facilities would not provide for the satisfactory needs of a tenant's patrons who must remain in a given area to receive the service rendered.

AUTHORITY NOTE: Promulgated in accordance with R.S. 40:4(A)(7) and R.S. 40:5(2)(3)(7)(9)(16)(17)(20).

HISTORICAL NOTE: Promulgated by the Department of Health and Hospitals, Office of Public Health, LR 38:2816 (November 2012), repromulgated LR 39:511 (March 2013), amended LR 41:390 (February 2015).

Building or Occupancy	Louisiana State Sanitary Code (LAC 51)
Wholesale Seafood Plants (Marine and Freshwater)	Part IX
Campsites	Part XVI
Jails, Prisons and Other Institutions of Detention or Incarceration (See §415.L.4 of this code)	Part XVIII
Hospitals, Ambulatory Surgical Centers, Renal Dialysis Centers	Part XIX
Nursing Homes	Part XX



### §413. Fixture Outlets

A. Lavatory Waste Outlets. Lavatories shall have waste outlets not less than 1 1/4-inch diameter. Waste outlets may have open strainers or may be provided with stoppers.

B. Sink Waste Outlets. Sinks shall be provided with waste outlets not less than 1 1/2-inch diameter. Waste outlets may have open strainers or may be provided with stoppers.

C. Strainers and Fixture Outlets. All plumbing fixtures, other than water closets and siphon-action washdown or blowout urinals, shall be provided with strainers having waterway area complying with Table 407 of this code.

D. Overflows. The following applies to overflows for plumbing fixtures.

1. Design. When any fixture is provided with an overflow, the waste shall be so arranged that the standing water in the fixture cannot rise in the overflow when the stopper is closed or remain in the overflow when the fixture is empty.

2. Connection. The overflow pipe from a fixture shall be connected on the house or inlet side of the fixture trap, except that overflows of flush tanks may discharge into the water closets or urinals served by them, but it shall be unlawful to connect such overflows with any other part of the drainage system.

AUTHORITY NOTE: Promulgated in accordance with R.S. 40:4(A)(7) and R.S. 40:5(2)(3)(7)(9)(16)(17)(20).

HISTORICAL NOTE: Promulgated by the Department of Health and Hospitals, Office of Public Health, LR 38:2823 (November 2012).

### §415. Fixture Types

A. Commercial Dishwashing Machines. The following applies to commercial dishwashing machines.

1. Protection. Commercial dishwashing machines shall meet the requirements of §§609 and 807.B of this code.

2. Waste Connection. Each unit may be separately trapped or discharge indirectly into a properly trapped and vented fixture. A commercial dishwashing machine shall not be directly connected to a drainage system. When a commercial dishwashing machine is located within 5 feet of a trapped floor drain, the dishwasher waste outlet may be connected directly on the inlet side of a properly vented floor drain trap.

3. Sanitization. Commercial dishwashing machines shall be installed and operated in accord with the manufacturer's recommendations and with the mechanical cleaning and sanitizing requirements contained within Part XXIII (Eating and Drinking Establishments) of the Louisiana State Sanitary Code (LAC 51:XXIII).

4. Flow Pressure. When spray-type dishwashing machines are used in commercial installations, the pressure measured in the final rinse water line shall be at least 15 psi (103 kPa) and not more than 25 psi (172 kPa) when the final rinse spray is operating. A suitable pressure gauge and gage cock shall be provided in a readily accessible location

immediately upstream from the final rinse sprays to permit checking the flow pressure of the final rinse water. If necessary, a permanently installed pressure regulator shall be provided on the final rinse water line in order to maintain the proper water pressure in the line when the final rinse spray is operating.

B. Domestic Dishwashing Machines. The following applies to domestic dishwashing machines.

1. Protection. Domestic dishwashing machines shall meet the requirements of §§609 and 807.B of this code.

2. Waste Connection. Each unit may be separately trapped or discharge indirectly into a properly trapped and vented fixture. A domestic dishwashing machine shall not be directly connected to a drainage system. It may be connected through a wye connection into the tail piece of a sink or into the body of a disposal unit with the flexible dishwasher hose looped up to within 2 inches of the bottom of the counter top.

C. Drinking Fountains. The following applies to drinking fountains.

1. Design and Construction. Drinking fountains shall conform to ASME A 112.19.1 or CSA B45.2 if of enameled cast iron or enameled steel; or ASME A 112.19.2 or CSA B45.1 if of ceramic. Mechanically refrigerated drinking fountains shall also conform to ARI 1010. All drinking fountains shall conform to NSF 61.

2. Protection of Water Supply. Stream projectors shall be so assembled as to provide an orifice elevation as specified by ASME A 112.1.2.

3. Prohibited Location. Drinking fountains shall not be installed in public toilet rooms.

4. Minimum Required Separation from Contamination. Drinking fountain fixtures shall provide a minimum of 18 inches of separation from its water outlet (spigot) to any source of contamination. Combination sink/drinking fountain units shall provide a minimum of 18 inches between the drinking fountain water outlet (spigot) and the nearest outside rim of the sink bowl [or other source(s) of contamination].

a. Exception. This 18 inch minimum separation may only be reduced by the use of a vertical shield made of a smooth, easily cleanable surface that is attached flush with the top surface of the unit and extends to a distance at least 18 inches in height above the drinking fountain water outlet (spigot) level.

b. Prohibited Fixture. Combination sink/drinking fountain units which share the same sink bowl are prohibited except in individual prison cells.

5. Minimum Fixture Requirements. Water dispensing type drinking fountains which connect to the potable water distribution system but require the use of an individual cup or container shall be permitted to substitute for not more than 50 percent of the required number of drinking fountains. Bottled water-type dispensers are prohibited from

counting toward the minimum required number of drinking fountains.

D. **Garbage Can Washers.** Garbage can washers shall be separately trapped. The receptacle receiving the wash from garbage cans shall be provided with a removable basket or strainer to prevent discharge of large particles into the building drainage system. Any water supply connection shall be protected against backflow by an air gap (water distribution) or an approved backflow prevention device.

E. **Floor Drains.** The following applies to floor drains.

1. **Installation.** The installation of floor drains shall comply with the following.

a. Floor drains shall connect into a trap so constructed that it can be readily cleaned and of a size to efficiently serve the purpose for which it is intended. The drain inlet shall be located so that it is, at all times, in full view and accessible.

b. Floor drains shall have a minimum 2-inch diameter drain outlet and connect to a trap no less than 2-inches in diameter.

c. Floor drains subject to backflow shall not be directly connected to the drainage system or shall be provided with a backwater valve.

d. Floor drains shall be provided with removable strainers meeting §807.G.2 of this code, the open area of which shall be not less than two-thirds of the cross-sectional area of the trap to which it connects.

2. **Required Locations.** Floor drains shall be installed in the following areas:

a. Floor drains shall be installed in all public toilet rooms, etc., (see definition of Public or Public Use in Chapter 2 of this code) and shall be fed (the water seal replenished) by an approved automatic trap priming device meeting the requirements of and installed in accordance with §415.E.4.a, §415.E.4.b, or §415.E.4.c of this code.

i. **Exceptions**

(a). Floor drains are not required in the toilet rooms serving hotel/motel guest rooms or patient rooms of hospitals and nursing homes.

(b). In existing ground floor construction, the addition of floor drains in public toilet rooms is only required when substantial renovation or fixture additions to the public toilet room(s) occurs which requires the concrete slab to be broken or when a serious health threat to the public exists.

b. In public coin operated laundries and in the central washing facilities of apartment buildings or in rooms containing connections for laundry machines except in one and two family dwellings, the rooms containing the laundry machines shall be provided with adequate floor drains located to readily drain the entire floor area. When such floor drains are not embedded in concrete, the floors shall be properly lined as required by §415.I.2 of this code and the

required floor drains shall meet the design criteria for shower drains in §415.I.1 of this code.

c. Recess rooms located within medical facilities which contain the recessed or concealed portions of sterilizers shall be provided with a minimum of one acceptable floor drain in accordance with §1305.C.2 of this code.

d. Each toilet room and laundry room in the service buildings of travel trailer parks shall be provided with a minimum 2-inch floor drain in accordance with §1509.F of this code.

3. **Prohibited Locations.** The following applies to prohibited locations of floor drains.

a. No floor drain or other plumbing fixture except electric water heaters shall be installed in a room containing air handling machinery when such room is used as a plenum. When rooms are used as a plenum, equipment drains shall be conveyed through an indirect waste receptor located outside such rooms or other approved point of disposal.

b. Floor drains directly connected to the plumbing system shall not be located in elevator pits.

c. No floor drains shall be permitted in food storage areas unless installed in accordance with §807.A of this code.

d. Floor drains are not permitted in walk-in coolers or freezers unless they are provided with indirect connections to the sanitary sewer located outside the walk-in cooler or freezer.

4. **Trap Seal Protection.** Floor drain or similar traps shall be regularly and automatically fed (the water seal replenished) by the addition of water, liquid waste, or industrial waste (such as the normal and regular operation of a plumbing fixture or condensate waste draining thereto) into the floor drain or, in lieu thereof, shall be protected by the use of:

a. an ASSE 1018 automatic trap priming device (see §625.D of this code);

b. an electronic potable water supply fed trap priming device meeting ASSE 1044 (see §625.D of this code);

c. a drainage type device meeting ASSE 1044 which captures liquid wastes only from:

i. the tail piece of a lavatory;

ii. the discharge side of the atmospheric vacuum breaker located downstream of a flushometer valve servicing a water closet or a clinical sink (the take off point on the discharge pipe must be at least 4" below the critical level of the vacuum breaker); or,

iii. the refill/hush tube of ballcocks (only on ballcocks that utilize an atmospheric vacuum breaker in accordance with the requirements of §609.C.2 of this code).

d. an ASSE 1072 listed barrier type floor drain trap seal protection device; or,

e. a combination of the methods listed above, i.e., the use of an ASSE 1072 device in addition to the use of either an ASSE 1018 or ASSE 1044 automatic trap priming device.

F. Food Waste Grinder Units. The following applies to food waste grinder units.

1. Separate Connections. Domestic food waste disposal units may be connected and trapped separately from any other fixture or compartment. Units may have either automatic or hand-operated water-supply control. See §609 of this code.

2. Commercial Type Grinders. Food grinders used in commercial buildings shall have an automatic water-supply and shall be provided with not less than 2-inch (51mm) waste line. Each waste line shall be trapped and vented as provided in other Sections of this code (see §1005.K.1 of this code).

G. Laundry Trays. The following applies to laundry trays.

1. Waste Outlets. Each compartment of a laundry tray shall be provided with a waste outlet not less than 1 1/2 inches in diameter.

2. Overflow. Laundry tray overflows shall conform to the requirements of §413.D of this code.

H. Multiple Washsinks. The following applies to multiple washsinks.

1. Circular Type. Each 18 inches (457 mm) of wash sink circumference (circular type), when provided with water outlets for such space, shall be equivalent to one lavatory.

2. Straight-Line Type. Multiple wash sinks of the straight-line type shall have hot and cold combination spouts not closer than 24 linear inches (610 mm) from adjacent similar spouts and each spout shall be considered the equivalent of one lavatory.

I. Shower Compartments. The following applies to shower compartments.

1. Shower. Shower compartments shall conform to Table 415.I of this Part and shall have approved shower pan material or the equivalent thereof as determined by the plumbing official. The pan shall turn up on three sides at least 2 inches (51 mm) above finished curb level. The remaining side shall wrap over the curb. Shower drains shall be constructed with a clamping device so that the pan may be securely fastened to the shower drain thereby making a watertight joint. Shower drains shall have an approved weephole device system to insure constant drainage of water from the shower pan to the sanitary drainage system. There shall be a watertight joint between the shower drain and trap. Shower receptacle waste outlets shall be not less than 2 inches and shall have a removable strainer.

a. Exception. Shower compartments with prefabricated receptors conforming to the standards listed in Table 415.I of this Part, or special use shower compartments for accessible use which comply with the ANSI A117.1 accessibility standard.

Table 415.I Prefabricated Shower Receptor Standards	
Materials	Standards
Plastic Bathtub and Shower Units	ANSI Z124.1.2
Chlorinated Polyethylene (CPE) Sheeting for Concealed Water-Containment Membrane	ASTM D 4068
Polyvinyl Chloride (PVC) Plastic Flexible Concealed Water-Containment Membrane	ASTM D 4551, See §303.G.7 of this code

2. Construction. Floors under shower compartments shall be laid on a smooth and structurally sound base and shall be lined and made watertight with sheet lead, copper or other acceptable materials.

3. Public or Institutional Showers. Floor of public shower rooms shall be drained in such a manner that no waste water from any shower head will pass over floor areas occupied by other bathers.

J. Special Fixtures. The following applies to special fixtures.

1. Water Drain and Connections. Baptistries, ornamental and lily pools, aquaria, ornamental fountain basins and similar constructions when provided with water supplies shall be protected from backsiphonage as required in §609.A and Table 609.F.6 of this code.

2. Approval. Specialties requiring water and waste connections shall be submitted for approval of the plumbing official.

3. Accessible Fixtures. Accessible fixtures shall comply with the requirements of ANSI A117.1.

K. Swimming Pools, Spas, and Hot Tubs. The following applies to swimming pools, spas, and hot tubs.

1. Water Circulation System Components. Water circulation system components and disinfectant equipment for swimming pools, spas or hot tubs shall meet the requirements of NSF 50. [For other swimming pool and spa requirements, also see Part XXIV (Swimming Pools) - Louisiana State Sanitary Code (LAC 51:XXIV)]

2. Suction Fittings. Suction fittings shall conform to ASME A 112.19.8 or APSP 16. Public, Residential Spas shall comply with the standards listed in the following Table 415.K below.

Table 415.K Public and Residential Spas Standards	
Materials	Standards
Public Spas	APSP-2
Residential Spas, Permanently Installed	APSP-3
Residential Spas, Portable	APSP-6

L. Urinals. The following applies to urinals.

1. Automatic Flushing Tank. Tanks flushing more than one urinal shall be automatic in operation and of sufficient capacity to provide the necessary volume to flush and properly cleanse all urinals simultaneously.

2. Urinals Equipped with Automatic Flush Valves. Flushometers shall be as prescribed in §415.N.5 of this code and no valve shall be used to flush more than one urinal.

3. Nonwater Urinals. Nonwater urinals shall conform with LAC 51:XIV.409.A.2.

4. Trough Urinals. Trough urinals may only be used for stadiums, arenas, and jails, prisons, or other institutions of detention or incarceration. Trough urinals, when used, shall conform to the following requirements:

a. Shall not be less than 6 inches deep and shall be furnished with one piece backs and have strainers with outlets at least 1 1/2 inches in diameter.

b. The washdown pipe shall be perforated so as to flush with an even curtain of water against the back of the urinal. This pipe shall be securely clamped as high as practicable to the back of the urinal. Trough urinals, where so equipped, shall have tanks with a flushing capacity of not less than 1 1/2 gallons of water for each 2 feet of urinal length.

c. Trough urinals shall be figured on the basis of one urinal for each 18 inches of length, provided that: 24-inch urinal equals 1 urinal; 36-inch urinal equals 2 urinals; 48-inch urinal equals 2 urinals; 60-inch urinal equals 3 urinals; and a 72-inch urinal equals 4 urinals.

5. Privacy. Privacy walls or partitions shall be provided for each urinal within public use and employee use toilet rooms used by males. Such walls or partitions shall conform to the following:

a. The wall or partition finish surface shall be non-absorbent, smooth, and easily cleanable.

b. The walls or partitions shall begin at a height of not more than 14 inches above the finished floor surface and shall extend not less than 60 inches above the finished floor surface.

c. The walls or partitions shall extend from the wall surface at each side of the urinal a minimum of 18 inches or to a point not less than 6 inches beyond the outermost front lip of the urinal measured from the finished back wall surface, whichever is greater.

i. Exceptions. The following conditions shall constitute an exception (or a partial exception) to the requirement for privacy walls or partitions for each urinal within public use toilet rooms used by males:

(a). toilet rooms having wall-hung trough urinals only (which are currently only allowed in stadiums, arenas, and in jails, prisons, and other places of detention or incarceration);

(b). toilet rooms used by children less than 5 years of age which are located in day care and child-care facilities and which contain two or more urinals shall be permitted to have one urinal without privacy walls or partitions; or,

(c). toilet rooms located in jails, prisons and other places of detention or incarceration.

M. Washing Machines for Residences. The following applies to washing machines for residences.

1. Protection. Domestic washing machines shall meet the requirements of §609.A of this code.

2. Separate Trap. Each unit shall be separately trapped or discharge indirectly into a properly trapped and vented fixture (see §1001.I of this code).

3. Cross Fittings. Automatic washing machines shall not be connected to a 2-inch or smaller cross-type fitting.

4. Central Facilities. When central washing facilities are provided in lieu of washing machine connections in each living unit, central facilities shall be located for the building served at the ratio of not less than one washing machine for each 12 living units, but in no case less than two machines for each building of 15 living units or less. See §415.E.2.b of this code.

N. Water Closets. The following applies to water closets.

1. Public Use. Water closet bowls for public use including, but not limited to, hotel and motel guest rooms and patient rooms of hospitals and nursing homes shall be of the elongated type.

2. Flushing Device. Water closet gravity, tanks, flushometer tanks and flushometer valves shall have a flushing capacity sufficient to properly flush the water closet bowls to which they are connected.

3. Float Valves. Float valves in water closet tanks shall close tight and provide water to properly refill the trap seal in the bowl.

4. Close-Coupled Tanks. The flush valve seat in close-coupled water closet combinations shall be 1 inch (25.4 mm) or more above the rim of the bowl, so that the flush valve will close even if the closet trapway is clogged. Any closets with flush valve seats below the rim of the bowl shall be so constructed that in case of trap stoppage, water will not flow continuously over the rim of the bowl.

5. Automatic Flush Valve. Flushometers shall be so installed that they will be readily accessible for repairing. When the valve is operated, it shall complete the cycle of operation automatically, opening fully and closing positively under the service pressure. At each operation, the valve shall deliver water in sufficient volume and at a rate that will thoroughly flush the fixture and refill the fixture trap. Means shall be provided for regulating flush valve flow. Not more than one fixture shall be served by a single flush valve.

6. Seats. Water closets shall be equipped with seats of smooth nonabsorbent material. All seats of water closets

provided for public use including, but not limited to, hotel and motel guest rooms and patient rooms of hospitals and nursing homes shall be of the open-front type. Integral water closet seats shall be of the same material as the fixture. The seat contour shall be the same contour as the water closet.

7. Water Closet Compartment. Each water closet utilized by the public or employees shall occupy a separate compartment with walls or partitions and a lockable door enclosing the individual fixture to ensure privacy. Such walls or partitions shall conform to the following:

a. The wall or partition finish surface shall be non-absorbent, smooth, and easily cleanable.

b. The walls or partitions shall begin at a height of not more than 14 inches above the finished floor surface (except when same would be higher than the bowl rim of a child-sized toilet) and shall extend not less than 66 inches above the finished floor surface. For child-sized toilets, the walls or partitions shall begin at a height no higher than the bowl rim of the child-sized toilet.

i. Exceptions. The following conditions shall constitute an exception (or a partial exception) to the requirement for separate compartments for each water closet:

(a). toilet rooms containing only a single water closet (or only a single water closet and lavatory) with a lockable door;

(b). toilet rooms located in day care and child-care facilities which care for children less than 5 years of age and containing two or more water closets shall be permitted to have one water closet without an enclosing compartment; or,

(c). toilet rooms located in jails, prisons and other institutions of detention or incarceration.

O. Whirlpool Bathtubs. The following applies to whirlpool bathtubs.

1. Access. An access panel of sufficient size shall be installed to provide access to the pump for repair and replacement.

2. Pump. When not factory assembled to the tub assembly, the circulation pump shall be accessibly located above the crown weir of the trap. The pump drain line shall be properly graded to assure minimum water retention in the volute after fixture use.

3. Operation. Leak testing and pump operation shall be performed in accordance with manufacturer's recommendations.

4. Hydro-massage Bathtubs. Hydro-massage bathtubs shall comply with ASME A 112.19.7.

5. Whirlpool Bathtub Appliances. Whirlpool bathtub appliances shall comply with ASME A 112.19.7.

6. Suction Fittings. Suction fittings for use in whirlpool bathtubs shall comply with ASME A 112.19.8 or APSP 16.

AUTHORITY NOTE: Promulgated in accordance with R.S. 40:4(A)(7), R.S. 40:5(2)(3)(7)(9)(16)(17)(20), and HCR 4 of the 2008 Regular Session.

HISTORICAL NOTE: Promulgated by the Department of Health and Hospitals, Office of Public Health, LR 38:2823 (November 2012).

#### **§417. Additional Provisions for Plumbing Fixtures**

A. Additional provisions for plumbing fixtures are contained in Chapter 13, Medical Facilities Plumbing Systems, of this code.

AUTHORITY NOTE: Promulgated in accordance with R.S. 40:4(A)(7) and R.S. 40:5(2)(3)(7)(9)(16)(17)(20).

HISTORICAL NOTE: Promulgated by the Department of Health and Hospitals, Office of Public Health, LR 38:2827 (November 2012).

### **Chapter 5. Water Heaters**

#### **§501. General**

A. Scope. The provisions of this Chapter shall govern the materials, design, and installation of water heaters.

B. Working Pressure Identification. All storage tanks and water heaters shall be clearly and indelibly marked showing the allowable safe working pressure.

C. Water Heater as Space Heater. A water heater may be used as a part of a space heating system if the outlet water temperature of the water heater does not exceed 160°F (71°C) and the potability of the water is maintained throughout the system.

D. Sediment Drains. A suitable water valve or cock, through which sediment may be drawn off or the heater or tank emptied, shall be installed at the bottom of the heater or tank.

E. Location. The following applies to the location of water heaters and/or associated storage tanks.

1. Water heaters and storage tanks shall be so located and connected that they will be accessible for observation, maintenance, servicing and replacement.

2. Gas water heaters in residential garages shall be installed so that all burners and burner ignition devices are located not less than 18 inches above the floor.

3. Gas water heaters shall be located, or reasonably protected, so that they are not subject to physical damage by a moving vehicle.

4. Every attic or furred space in which water heaters and/or storage tanks are installed shall be readily accessible by an opening and passageway as large as the largest piece of equipment and in no case less than 22 x 36 inches (559 x 914 mm) continuous from the opening to the equipment and its controls. The opening to the passageway should be located not more than 20 ft (6096 mm) from the equipment measured along the center line of such passageway. Every passageway shall be unobstructed and shall have solid continuous flooring not less than 24 inches (610 mm) wide from the entrance opening to the equipment. On the control side and on other sides where access is necessary for

servicing of equipment, a level working platform extending a minimum 30 inches (762 mm) from the edge of the equipment with a 36 inch (914 mm) high clear working space shall be provided.

F. Marking. All water heaters and associated storage tanks shall comply with the following marking requirements.

1. Water Heaters. All water heaters shall bear the following, or equal wording on a visible decal or label by the manufacturer:

There shall be installed at time of heater installation a combination temperature and pressure relief valve, selected and located in conformance with the requirements of ANSI Z21.22 or CSA 4.4M.

2. Pressure Marking of Storage Tanks. Any storage tank installed for domestic hot water shall have clearly and indelibly stamped in the metal, or so marked upon a plate welded thereto or otherwise permanently attached, the maximum allowable working pressure. Such markings shall be in an accessible position outside of the tank so as to make inspection or reinspection readily possible. All unlisted storage tanks for domestic hot water shall meet the applicable ASME standards.

AUTHORITY NOTE: Promulgated in accordance with R.S. 40:4(A)(7) and R.S. 40:5(2)(3)(7)(9)(16)(17)(20).

HISTORICAL NOTE: Promulgated by the Department of Health and Hospitals, Office of Public Health, LR 38:2827 (November 2012).

**§503. Standards**

A. Electric Water Heaters. Electric residential water heaters shall comply with UL 174.

B. Gas Water Heaters. Automatic storage type gas water heaters with inputs of 75,000 Btuh (22 kW), or less shall comply with ANSI Z21.10.1 or CSA 4.1. Circulating tank, instantaneous and large automatic storage type gas water heaters shall comply with ANSI Z21.10.3 or CSA 4.3.

C. Testing and Listing. Water heaters shall be tested and listed by an approved agency.

AUTHORITY NOTE: Promulgated in accordance with R.S. 40:4(A)(7) and R.S. 40:5(2)(3)(7)(9)(16)(17)(20).

HISTORICAL NOTE: Promulgated by the Department of Health and Hospitals, Office of Public Health, LR 38:2828 (November 2012).

**§505. Minimum Capacities for Residential Water Heaters**

A. Water heaters installed in residential occupancies may be sized in accordance with the following Table 505.

Table 505											
Minimum Capacities For Water Heaters <sup>1,2</sup>											
Number of Bathrooms	1 to 1.5			2 to 2.5			3 to 3.5				
Number of Bedrooms	1	2	3	2	3	4	5	3	4	5	6
First Hr Rating Gal.	42	54	54	54	67	67	80	67	80	80	80
Nom. Tank Size, Gal.											
Gas Water Heaters	20	30	30	30	40	40	50	40	50	50	50
Elect. Water Heaters	30	50	50	50	66	66	80	66	80	80	80
Oil Water Heaters	30	30	30	30	30	30	30	30	30	30	30

NOTES:

1. The main criteria for a properly sized water heater is a sufficient first hour rating to meet peak hot water demand. The majority of tank sizes shown in the table will have a first hour rating equal to or greater than the first hour rating indicated. A water heater with a smaller tank size than shown in the table but with a sufficient first hour rating shall be permitted.

2. The first hour rating is found on the "Energy Guide" label.

B. Non-storage and solar water heaters shall be sized with sufficient capacity to meet the appropriate first hour rating shown in Table 505 above.

AUTHORITY NOTE: Promulgated in accordance with R.S. 40:4(A)(7) and R.S. 40:5(2)(3)(7)(9)(16)(17)(20).

HISTORICAL NOTE: Promulgated by the Department of Health and Hospitals, Office of Public Health, LR 38:2828 (November 2012).

**§507. Prohibited Installations**

A. Water heaters (using solid, liquid or gas fuel) with the exception of those having direct vent systems, shall not be installed in bathrooms and bedrooms or in a closet with access only through a bedroom or bathroom. However, water heaters of the automatic storage type may be installed as replacement in a bathroom, when specifically authorized by the plumbing official, provided they are properly vented and supplied with adequate combustion air.

1. Exception. When a closet, having a weather-stripped solid door with an approved door closing device, has been designed exclusively for the water heater and where all air for combustion and ventilation is supplied from outdoors.

B. Water heaters (using solid, liquid or gas fuel) shall not be installed in a room containing air handling machinery when such room is used as a plenum.

AUTHORITY NOTE: Promulgated in accordance with R.S. 40:4(A)(7) and R.S. 40:5(2)(3)(7)(9)(16)(17)(20).

HISTORICAL NOTE: Promulgated by the Department of Health and Hospitals, Office of Public Health, LR 38:2828 (November 2012).

**§509. Connections**

A. A shutoff valve shall be provided in the cold water branch line to each water storage tank or each water heater, on the same floor within 3 feet of the heater. Full port ball valve shut-offs on cold water branch lines to 2 inches or full port ball or resilient wedge-type shut-off valves for 2 1/2-inch lines and larger shall be used. The valving shall not interfere or cause a disruption of the cold water supply to the remainder of the cold water system.

B. The method of connecting a circulating water heater to the tank shall assure proper circulation of water through the heater, and permit a safe and useful temperature of water to be drawn from the tank. The pipe or tubes required for the installation of appliances which will draw from the water heater or storage tank shall be subject to the applicable provisions of this code for material and installation.

AUTHORITY NOTE: Promulgated in accordance with R.S. 40:4(A)(7) and R.S. 40:5(2)(3)(7)(9)(16)(17)(20).

HISTORICAL NOTE: Promulgated by the Department of Health and Hospitals, Office of Public Health, LR 38:2828 (November 2012).

**§511. Safety Devices**

A. Anti-Siphon and Vacuum Relief Devices. Anti-siphon and vacuum relief devices shall be provided and installed in accord with the following.

1. Means acceptable to the plumbing official shall be provided to prevent siphoning of any water heater or tank to which any water heater or tank is connected. A cold water "dip" tube with a hole at the top or a vacuum relief valve installed in the cold water supply line above the top of the heater or tank may be accepted for this purpose.

2. Bottom fed heaters or bottom fed tanks connected to water heaters shall have a vacuum relief valve installed. The vacuum relief valve shall be in compliance with the appropriate requirements of ANSI Z21.22 or CSA 4.4M.

B. Water Temperature Control in Piping from Tankless Heaters. The temperature of water from tankless heaters shall be tempered to 140°F (60°C) when intended for domestic uses. This provision shall not supersede the requirement for protective valves per §623 of this code.

C. Relief Valve. All storage water heaters operating above atmospheric pressure shall be provided with an approved, self-closing (levered) pressure relief valve and temperature relief valve or combination thereof, except for nonstorage instantaneous heaters. Such valves shall be installed in the shell of the water heater tank or may be installed in the hot water outlet, provided the thermo-bulb extends into the shell of the tank. Temperature relief valves shall be so located in the tank as to be actuated by the water in the top one-eighth of the tank served. For installations with separate storage tanks, said valves shall be installed on the tank and there shall not be any type of valve installed between the water heater and the storage tank. There shall not be a check valve or shutoff valve between a relief valve and the heater or tank which it serves. The relief valve shall not be used as a means of controlling thermal expansion (see §623.D of this code).

D. Energy Cutoff Device. All automatically controlled water heaters shall be equipped with an energy cutoff device which will cut off the supply of heat energy to the water tank before the temperature of the water in the tank exceeds 210°F (99°C). This cutoff device is in addition to the temperature and pressure relief valves.

E. Relief Valve Approval. Temperature and pressure relief valves, or combinations thereof, or energy shutoff devices shall bear the label of the AGA or ASME, with a thermosetting of not more than 210°F (99°C) and pressure setting not to exceed the tank or heater manufacturer's rated working pressure. The relieving capacity of these two devices shall each equal or exceed the heat input to the water heater or storage tank.

F. Relief Outlet Waste. The outlet of a pressure, temperature, or other relief valve shall not be directly connected to the drainage system.

G. Heater Over 200,000 Btuh Input. The relief valve shall have a minimum AGA temperature steam rating of 200,000 Btu (211,000 kJ), shall comply with all construction, testing and installation requirements of ANSI Z21.22 or CSA 4.4M, and shall have minimum 1-inch inlet and outlet pipe size connections. In addition, the temperature relieving element of the valve shall have a water discharge capacity based on 1250 Btu (1319 kJ) for each gallon per hour of water discharged at 30 psi (207 kPa) working pressure and a maximum temperature of 210°F (99°C). This rating must be certified by the valve manufacturer. Also, the pressure relieving element of the valve shall be ASME pressure steam rated. Both the temperature water rating and the ASME pressure steam rating of the combination temperature and pressure relief valve shall be equal to or in excess of the input to the hot water storage tank or storage water heater.

H. Safety Pans and Relief Valve Waste. Safety pans and relief valve waste piping shall comply with the following.

1. When water heaters or hot water storage tanks are installed in remote locations such as suspended ceiling spaces or in attics, the tank or heater shall rest in a galvanized steel or other metal pan of equal corrosive resistance having a thickness at least equal to 0.0276-inch (0.7 mm) galvanized sheet steel.

a. Exception. Electric water heaters may rest in a high impact plastic pan of at least 1/16-inch (1.6 mm) thickness.

2. Safety pans shall be no less than 1 1/2 inches (38mm) deep and shall be of sufficient size and shape to receive all drippings or condensate from the tank or heater. The pan shall be drained by a pipe no less than 1-inch (25.4 mm) diameter.

3. The pan drain shall extend full-size and terminate over a suitably located indirect waste receptor or floor drain or extend to the exterior of the building and terminate no less than 6 inches (152 mm) or more than 24 inches (610 mm) above finish grade<sub>(G)</sub>.

4. The discharge from the relief valve shall be piped full-size separately to the outside of the building or to an indirect waste receptor so that any discharge can cause no personal injury or property damage and can be readily observed by the building occupants. Relief valve discharge piping shall contain no valves or traps and shall be so graded and connected as to drip to the discharge end of the piping by gravity. When the relief valve discharge is piped to the outside of the building, it shall terminate no less than 6 inches (152 mm) and no more than 24 inches (610 mm) above finish grade<sub>(G)</sub>.

5. Relief valve discharge piping shall be of those materials listed in §619 or Table 511 of this code, or shall be tested and rated for such use.

Table 511 Relief Valve Materials	
Material(s)	Standard
Water Heater Relief Valve Drain Tubes	ASME A 112.4.1

AUTHORITY NOTE: Promulgated in accordance with R.S. 40:4(A)(7) and R.S. 40:5(2)(3)(7)(9)(16)(17)(20).

HISTORICAL NOTE: Promulgated by the Department of Health and Hospitals, Office of Public Health, LR 38:2828 (November 2012).

### §513. Solar Water Heating Systems

A. Solar energy systems used for heating potable water or using an independent medium for heating potable water shall comply with the applicable requirements of this code. The use of solar energy shall not compromise the requirements for cross connection or protection of the potable water distribution system, water service pipe, or water supply system required by this code. Solar energy systems shall also meet the applicable requirements of the state-adopted energy code and the applicable codes adopted under the authority of Act 12 of the 2005 First Extraordinary Session.

B. Definitions. Definitions contained in Chapter 2 of this code shall also apply to this Section except where the following special definitions shall apply.

*Active Solar System*—a solar water heating system that utilizes an electric pump and controllers to circulate heat transfer fluid through the solar collectors.

*Auxiliary Heating Equipment*—equipment utilizing energy other than solar, to supplement the output provided by the solar energy system.

*Closed Loop System*—system where the collector loop heat transfer fluid is enclosed in a piping loop separate from the potable water supply.

*Collector Loop*—the piping of a collector system in which a *heat transfer fluid* circulates between the *solar collector(s)* and a heat exchanger.

*Direct-Circulation System*—a system where the *potable water* is heated as a result of being circulated directly through the collectors (these systems are prohibited).

*Double Wall Heat Exchanger*—a heat exchanger design in which a single failure of any fluid barrier will not cause a cross connection or permit back siphonage of *heat transfer fluid* into the *potable water supply*. Any barrier which fails shall allow the discharge of *heat transfer fluid* and/or *potable water* to the atmosphere at a location visible to the operator or owner.

*Drainback System*—liquid system that only fills the collector when the temperature differential is appropriate. The water that is circulated through the collectors is stored in a reservoir.

*Engineered Solar System*—a system designed for a specific building project with drawings and specifications indicating materials to be installed, all as prepared by a person registered or licensed to perform solar design work.

*Heat Transfer Fluid*—the operating or thermal storage liquid in a mechanical system, including water or other liquid base, and additives at the concentration present under

operating conditions used to move heat from one location to another. Refrigerants are not included as *heat transfer fluids*.

*Human Consumption*—the use of water by humans for drinking, cooking, bathing, showering, hand washing, dishwashing, or maintaining oral hygiene.

*IAF*—International Accreditation Forum, the world association of Conformity Assessment Accreditation Bodies and other bodies interested in conformity assessment in the fields of management systems, products, services, personnel and other similar programs of conformity assessment. Its primary function is to develop a single worldwide program of conformity assessment which reduces risk for business and its customers by assuring them that accredited certificates may be relied upon. Accreditation assures users of the competence and impartiality of the body accredited.

*IAF MLA Signatory*—The objective of the *IAF MLA* is to ensure that the personnel certifications granted by signatories of the *IAF MLA* can be recognized by other signatories, increasing the worldwide employability of the certified professionals. Mutual recognition is based on peer evaluations between signatories to ensure each other's personnel certifications are equivalent and that each certified professional can perform the required tasks. Once an accreditation body is a signatory of the *IAF MLA* it is required to recognize the certificates issued by conformity assessment bodies accredited by all other signatories of the *IAF MLA*, with the appropriate scope. Accreditations granted by *IAF MLA* signatories are recognized worldwide based on their equivalent accreditation programs, therefore reducing costs and adding value to business and consumers. Accreditation body members of *IAF* are admitted to the *MLA* only after stringent evaluation of their operations by a peer evaluation team. For a complete list of *IAF* members and signatories visit: [http://www.iaf.nu/articles/IAF\\_MEM\\_USA\\_\\_all/112](http://www.iaf.nu/articles/IAF_MEM_USA__all/112).

*IECI*—International Electrotechnical Commission.

*Indirect-Circulation System*—a *closed loop* solar water heating system which prohibits contact between the *heat transfer fluid* and the potable water by the use of a heat exchanger to transfer the collected heat from the heat transfer fluid to the potable water.

*ISO*—International Organization for Standardization.

*ISO/IEC Guide 65*—a document that specifies requirements for bodies that operate third-party certifications of products to ensure that those bodies conduct their certification processes in an impartial, reliable, and consistent manner. Conformity to these standards provides assurance that a certification program is of high quality, integrity, and competency, and that it is free of any conflicts of interest, such as financial, commercial, or social influences.

*Listed*—equipment or materials included in a list published by an approved nationally recognized testing laboratory, inspection agency or other organization concerned with product evaluation that maintains periodic inspection of production of listed equipment or materials,



and whose listing states either that the equipment or material meets nationally recognized standards or has been tested and found suitable for use in a specified manner. The means for identifying listed equipment may vary for each testing laboratory, inspection agency, or other organization concerned with product evaluation, some of which do not recognize equipment as listed unless it is also labeled. The plumbing official should utilize the system employed by the listing organization to identify a listed product.

*MLA*—Multilateral Recognition Arrangement, to ensure mutual recognition of accredited certification between signatories to the *MLA*, and subsequently acceptance of accredited certification in many markets based on one accreditation.

*Potable Water*—water having bacteriological, physical, radiological and chemical qualities that make it safe and suitable for *human consumption*.

*Potable Water Supply*—a publicly owned or privately owned water supply system which purveys *potable water*.

*Readily Accessible*—having direct access without the need of removing any panel, door or similar covering of the item described and without requiring the use of portable ladders, chairs, etc.

*Solar Collector*—a device designed to absorb radiation from the sun and transfer this energy to a fluid which passes through the collector.

*Solar Water Heating System*—any unit or package of components designed to collect, convey, store, and convert the sun's energy for the purpose of heating *potable water*

*SRCC*—Solar Rating and Certification Corporation

*Toxic*—a substance that causes injury, illness, or death, especially by chemical means.

C. General. The following general requirements shall be applicable to solar water heating systems.

1. Certification. Solar water heating systems shall be certified to the Solar Rating and Certification Corporation's (SRCC) OG-300 document, 2010 edition (Operating Guidelines and Minimum Standards for Certifying Solar Water Heating Systems) by the SRCC themselves or by listing agencies [such as the International Association of Plumbing and Mechanical Officials (IAPMO)] which are currently accredited as meeting the ISO/IEC Guide 65 by the American National Standards Institute (ANSI) or other IAF MLA signatory accreditation bodies.

2. Installation. Solar water heating systems and appurtenances shall comply with the requirements of this Section, other applicable provisions of this code, and any other applicable requirements of the codes adopted under the authority of Act 12 of the 2005 First Extraordinary Session. All parts of a solar water heating system involving plumbing shall be installed by individuals holding a valid plumber's license issued by the State Plumbing Board of Louisiana (SPBLA), subject to any exceptions thereto as may be authorized under the SPBLA's law and regulations.

a. Solar water heating systems shall be installed in a manner conforming to this Section, other applicable provisions of this code, applicable standards, and the manufacturers' installation instructions. In instances where this Section, other applicable provisions of this code, applicable standards, or the manufacturers' instructions conflict, the more stringent provisions shall prevail.

3. Maintenance. Solar water heating systems shall be maintained in proper safe and sanitary operating condition, and the owner shall be responsible for maintenance.

a. Access for maintenance and repair shall be provided to solar water heating system equipment, components, valves, etc. Solar water heating equipment and appurtenances shall not obstruct or interfere with the operation of any doors, windows, or other building components requiring operation or access.

4. Safety. Any solar water heating system capable of providing hot water in excess of 140<sup>0</sup> F (60<sup>0</sup>C) shall be equipped with a listed tempering valve or temperature-limiting device to limit the temperature of water delivered to the domestic hot water system to a maximum of 140<sup>0</sup> F (60<sup>0</sup>C).

a. Solar water heating equipment that could generate a glow, spark, or flame capable of igniting flammable vapors may be installed in a residential garage provided the pilots and burners, heating elements, motors, controllers, or switches are at least 18 inches (457 mm) above the floor level.

D. Solar Water Heating System Design Criteria. Solar water heating system design criteria shall be as follows.

1. Overall System Design. All solar water heating systems shall be of the closed loop type, utilizing an indirect circulation system. Direct circulation systems are prohibited.

a. Solar water heating systems shall have flow directions indicated on system components and piping or shall have flow directions indicated on a diagrammatic representation of the system as installed, permanently affixed to the system hardware in a readily accessible and visible location.

b. The solar water heating system shall be valved to provide for shut-off from the service water supply without interrupting normal cold water service to the residence (see §509.A of this code and apply).

2. Freeze Protection. Solar water heating system components shall be protected from damage resulting by freezing of heat transfer liquids at the lowest ambient temperatures that will be encountered during the operation of the system.

a. Solar water heating systems, where the design requires piping to be drained to protect the system from freezing, or where the heat transfer fluid must be replaced as part of regular maintenance, shall have all piping pitched toward a designated point in the system to accomplish the intended purpose.

3. Temperature and Pressure. Solar water heating system components (i.e., solar collector, storage tank, heat exchanger, piping) containing pressurized fluids shall be protected against pressures and temperatures exceeding design limitations with a properly installed temperature and pressure (T and P) relief valve. Each section of the system in which excessive temperatures and pressures are capable of developing shall have a T and P relief valve located so that a section cannot be valved off or otherwise isolated from protection by a properly installed a T and P relief valve.

a. Relief valves and its discharge piping and appurtenances shall meet the requirements listed in §§511.E through 511.H.5 of this code.

b. Vacuum relief valves shall be installed at the high point of the solar system for drain back systems unless specifically not required by the system design.

4. Thermal Contraction and Expansion. The solar water heating system design, components and subassemblies shall include adequate provisions for the thermal contraction and expansion of heat transfer fluids and system components that will occur over the design temperature range.

a. Provisions for thermal contraction and expansion within the potable water system shall be installed in accordance with the requirements of §623.D of this code, as it relates to the water being heated for consumer use.

5. Solar Collectors. Collectors that are manufactured as a complete component shall be listed by a recognized third party listing agency. Collectors shall be listed and labeled to show the manufacturer's name, model number, serial number, collector weight, collector maximum allowable temperatures and pressures, and the type of heat transfer fluids that are compatible with the collector. The label shall clarify that these specifications apply only to the collector.

a. Valves shall be installed to allow the solar collectors to be isolated from the remainder of the solar water heating system. Each isolation valve shall be labeled with the open and closed position.

b. Collectors shall be anchored to roof structures or other surfaces in a manner to resist wind, snow, or seismic loadings in compliance with the applicable(s) codes adopted under the authority of Act 12 of the 2005 First Extraordinary Session. Anchors secured to and through a roofing material shall be made in a manner to maintain the water integrity of the roof covering. Roof drainage shall not be impaired by the installation of collectors. Collector panels that are not an integral part of the roofing system shall be installed in a manner so as to preserve the integrity of the roof surface.

6. Heat Exchangers. Heat exchangers used for potable water heating shall protect the potable water system from being contaminated by the heat transfer fluid.

a. Heat exchangers that are of double-walled construction shall be utilized that separate the potable water from the heat transfer fluid by providing a space between the two walls that is vented to the atmosphere. The heat

exchanger design shall be such that any failure of a barrier material shall allow the discharge of exchanger fluid and/or potable water to the atmosphere. The discharge location shall be visible to the operator or owner of the system and be located so that no hazards are created by such discharge.

b. Single-walled heat exchangers are prohibited.

7. Heat Transfer Fluid. Heat transfer fluid shall be compatible with all materials in the system. The flash point of the actual heat transfer fluid utilized in a solar water heating system shall be not less than 50°F (10°C) above the design maximum stagnation (no-flow) temperature of the fluid attained in the collector.

a. Only non-toxic fluids shall be utilized as the heat transfer fluid, including additives, such as anti-freeze agents, conditioners, or corrosion inhibitors.

8. Storage or Heat Exchanger Tank Construction. All tanks shall be tested and listed by an approved agency. Pressurized thermal storage units shall be listed and labeled to show the manufacturer's name, model number, serial number, storage unit maximum and minimum allowable operating temperatures and pressures, and the type of heat transfer fluids that are compatible with the storage unit. The label shall clarify that these specifications apply only to the thermal storage unit.

a. Tank covers shall be structurally designed to withstand all anticipated loads and pressures.

b. All devices attached to or within the tank shall be accessible for repair and replacement.

9. Auxiliary Heating System. Auxiliary water heating equipment shall be provided such that the combined system (i.e., solar water heating system and the auxiliary water heating equipment) will provide the same degree of reliability and performance as a conventional water heating system.

a. Auxiliary (non-solar) water heating equipment shall be compatible with the solar system heat output, temperatures, flow rates and fluid types. Auxiliary water heating equipment shall be listed and labeled by a recognized third party listing agency.

b. The piping system shall be provided with valves which can be closed for the purpose of isolating the solar hot water heating system from the auxiliary water heater, thereby permitting operation of the auxiliary water heating system when the solar water heating system is inoperative or being serviced.

c. Auxiliary water heaters shall meet all applicable requirements set forth in this Chapter.

E. Potable Water Supply. The potable water supply shall be protected from an actual or potential cross connection to any nonpotable water piping by having any nonpotable water piping (e.g., heat transfer fluid piping) color coded/identified in accordance with §607 of this code.

F. Materials. Subject to any additionally limitations below, all plumbing used in the solar water heating system

including, but not limited to the collector loop, shall consist of the water distribution pipe, tubing and fittings materials specified in §619 of this code. Such materials shall comply with the standards listed in Table 603 of this code.

1. All hard-drawn copper tubing, in addition to the required incised marking, shall be marked in accordance with Sections 19.3.1 and 19.3.2 of ASTM B88-99 *Standard Specification for Seamless Copper Water Tube*. The colors shall be: Type K, green; Type L, blue. (Please note that Type M is not approved for plumbing uses in Louisiana).

2. Cast-iron fittings up to and including 2 inches in size, when used in connection with piping, shall be galvanized.

3. All malleable iron fittings shall be galvanized.

4. Flexible corrugated water heater connectors of copper or stainless steel shall be limited to 24 inches in length.

5. PEX tubing shall not be installed within the first 18 inches of piping connected to a water heater.

6. In no case shall plastic pipe including, but not limited to chlorinated polyvinyl chloride (CPVC) pipe and fittings, be used in a collector loop.

7. The piping of the collector loop shall be insulated to a minimum R-value of 2.6.

G. Testing. Testing of solar water heating systems and its components shall be performed in accordance with the following.

1. Closed Loop System. Closed loop or other type pressure systems shall be tested at one and one-half times maximum designed operating pressure. All systems shall withstand the test without leaking for a period of not less than 15 minutes.

2. Storage Tanks. Storage tanks associated with solar water heating systems shall be tested in accordance with the following.

a. Pressure type storage tanks shall be tested as prescribed in §513.G.1 of this code above.

b. Non-pressure type storage tanks shall be tested by filling it with water for a period of 24 hours prior to inspection and shall withstand the test without leaking. No tank or portion thereof shall be covered or concealed prior to approval.

H. Abandonment. Every abandoned solar water heating system or part thereof shall be physically disconnected from any remaining part of the plumbing system, drained, and plugged or capped in an approved manner.

AUTHORITY NOTE: Promulgated in accordance with R.S. 40:4(A)(7) and R.S. 40:5(2)(3)(7)(9)(16)(17)(20).

HISTORICAL NOTE: Promulgated by the Department of Health and Hospitals, Office of Public Health, LR 38:2829 (November 2012).

## Chapter 6. Water Supply and Distribution

### §601. General

A. Scope. The provisions of this Chapter shall govern the materials, design, construction, and installation of water supply and distribution systems.

B. Disinfection of Potable Water System. The plumbing official may require that a potable water system or any part thereof installed or repaired be disinfected in accordance with one of the following methods before it is placed in operation.

1. The system, or part thereof, shall be filled with a solution containing 50 ppm of available chlorine and allowed to stand 6 hours before flushing and returning to service.

2. The system, or part thereof, shall be filled with a solution containing 100 ppm of available chlorine and allowed to stand 2 hours before flushing and returning to service.

3. In the case of a potable water storage tank where it is not possible to disinfect as provided in Paragraph 1 or 2 of §601.B of this code above, the entire interior of the tank shall be swabbed with a solution containing 200 ppm of available chlorine and the solution allowed to stand 2 hours before flushing and returning to service.

4. In the case of potable water filters or similar devices, the dosage shall be determined by the plumbing official.

C. Allowance for Character of Water/Prohibition on the use of Used Piping. The material selected for water supply pipe, tubing, and fittings shall comply with the following.

1. Selection of Materials. When selecting the material and size for water supply pipe, tubing, or fittings, due consideration shall be given to the action of the water on the interior and of the soil, fill or other material on the exterior of the pipe. No material that would produce toxic conditions in a potable water distribution system shall be used for piping, tubing or fittings. Black iron pipe and fittings are prohibited in the water supply, service and distribution system.

2. Used Piping. A piping material that has been used for other than a potable water distribution system shall not be reused in the potable water distribution system.

D. Hot Water Distribution. The hot water supply to any fixture requiring hot water shall be installed on the left side of the fixture unless otherwise specified by the manufacturer.

E. Tests. The water supply and distribution system shall be tested in accordance with §319.C of this code.

F. Water Supply Mandatory. Every building used for human occupancy or habitation in which plumbing fixtures are installed shall be provided with an ample supply of potable water.

PUBLIC HEALTH—SANITARY CODE

AUTHORITY NOTE: Promulgated in accordance with R.S. 40:4(A)(7) and R.S. 40:5(2)(3)(7)(9)(16)(17)(20).

HISTORICAL NOTE: Promulgated by the Department of Health and Hospitals, Office of Public Health, LR 38:2832 (November 2012).

**§603. Materials**

A. Water service pipe and fittings shall be of materials specified in 613. Water distribution pipe, tubing and fittings shall be of materials specified in §619 of this code. Materials shall comply with the standards listed in the following Table 603.

<b>Table 603 Water Pipe and Fitting Materials</b>	
<b>Materials</b>	<b>Standards</b>
<b>Plastic Water Pipe and Fittings</b>	
ABS and PVC Plastic Tubular Fittings	NSF 24
Chlorinated Poly(vinyl chloride) (CPVC) Plastic Pipe Fittings, Socket-Type Schedule 40	ASTM F 438
Chlorinated Poly(vinyl chloride) (CPVC) Plastic Pipe Fittings, Schedule 80, 2" and Under	ASTM F 439, Listed
Chlorinated Poly (Vinyl Chloride) (CPVC) Plastic Pipe, Schedule 80, 2" and Under	ASTM F 441/F 441M, Listed
Chlorinated Poly (Vinyl Chloride) (CPVC) Plastic Pipe (SDR-PR)	ASTM F 442/F 442M
Chlorinated Poly (Vinyl Chloride) (CPVC) Plastic Hot and Cold Water Distribution Systems	ASTM D 2846/D 2846M, Listed
Cold-Expansion Fittings With Metal Compression-Sleeves for Cross-Linked Polyethylene (PEX) Pipe	ASTM F 2080
Cold Expansion Fittings with PEX Reinforcing Rings for Use with Cross-Linked Polyethylene (PEX) Tubing	ASTM F 1960
Cross-Linked Polyethylene/Aluminum/Cross-Linked Polyethylene (PEX-AL-PEX) Pressure Pipe and Fittings	ASTM F 1281
Cross-Linked Polyethylene (PEX) Plastic Hot-and Cold-Water Distribution System	ASTM F 877, Listed
Cross-Linked Polyethylene (PEX) Tubing	ASTM F 876
Cross-Linked Polyethylene (PEX) Tubing Systems for Pressure	CAN/CSA B 137.5, Listed
Flexible Elastomeric Pressure Joints	ASTM D 3139, See §313.H.1 of this code
Joints for IPS PVC Pipe Using Solvent Cement	ASTM D 2672
Metal Insert Fittings Utilizing a Copper Crimp Ring for SDR9 Cross-linked Polyethylene (PEX) Tubing	ASTM F 180
Plastic Insert Fittings Utilizing a Copper Crimp Ring for SDR9 Cross-linked Polyethylene (PEX) Tubing	ASTM F 2159
Polyethylene/Aluminum/Polyethylene (PE-AL-PE) Composite Pressure Pipe and Fittings	ASTM F 1282
Polyethylene Plastic Pipe & Tubing (PE) Number 2305, 2306, 3306, 3406, 3408, 3608, 4710	ASTM D 2239, ASTM D 2737, Listed, See §303.H.1 of this code
Poly (Vinyl Chloride) (PVC) Plastic Pipe Fittings, Schedule 40	ASTM D 2466
Pressure Rated ABS-Plastic Pipe Number 1210, 2112, 1316	ASTM D 1527, Listed, See §303.H.1 of this code
Pressure-rated Polypropylene (PP) Piping Systems	ASTM F 2389
Push Fit Fittings (for use on PEX tubing complying with ASTM F 876 or F877, type K and L hard drawn and annealed copper tubing	ASSE 1061

<b>Table 603 Water Pipe and Fitting Materials</b>	
<b>Materials</b>	<b>Standards</b>
complying with ASTM B 88 and CPVC tubing complying with ASTM D 2846)	
PVC Injection Molded Gasketed Fittings for Pressure Applications	CAN/CSA-B137.2, Listed
PVC Plastic Pipe, Number 1120, 1220	ASTM D 1785, ASTM D 2241, Listed, See §303.H.1 of this code
PVC Plastic Pipe Fittings, Schedule 80	ASTM D 2467, Listed
PVC Plastic Pipe Fittings, 4 in. through 12 in.	AWWA C 900
Stainless Steel Clamps for Securing SDR9 Cross-linked Polyethylene (PEX) Tubing to Metal Insert and Plastic Insert Fittings	ASTM F 2098
Threaded Chlorinated Poly (Vinyl Chloride) (CPVC) Plastic Pipe Fittings, Schedule 80, 2" and Under	ASTM F 437, Listed
<b>Ferrous Water Pipe &amp; Fittings</b>	
Cast Iron Castings for Valves, Flanges, and Pipe Fittings	ASTM A 126
Cupola Malleable Iron Fittings	ASTM A 197/A 197M
Ductile-Iron Compact Fittings for Water Service	AWWA C153, ANSI A 21.53
Ductile-Iron Pressure Pipe	ASTM A 377
Ductile-Iron Water Pipe	AWWA C 151, ANSI A 21.51
Ductile-Iron Water Fittings	AWWA C110, ANSI A 21.10
Gray Iron Threaded Fittings, Classes 125 and 250	ASME B 16.4
Malleable Iron Threaded Fittings, Classes 150 and 300	ASME B 16.3
Pipe Nipples for Welded and Seamless Carbon Steel and Austenitic Stainless Steel	ASTM A 733
Steel Couplings, Threaded and Galvanized	ASTM A 865/A 865M
Stainless Steel-Seamless, Welded, and Heavily Cold Worked Austenitic Piping (Types 304/304L & 316/316L only)	ASTM A 312/A 312M
Stainless Steel Tubing for General Service (Types 304/304L & 316/316L only)	ASTM A 269, See §303.H.3 of this code
Stainless Steel-Welded, Un-Annealed Austenitic Tubular Products (Types 304/304L & 316/316L only)	ASTM A 778
Steel Pipe, Hot-Dipped, Zinc-Coated, Welded and Seamless	ASTM A 53/A 53M
Nonferrous Pipe & Fittings Cast Bronze Threaded Fittings, Class 125 and 250	ASME B 16.15
Cast Copper Alloy Solder-Joint Pressure Fittings	ASME B 16.18
Cast Copper Alloy Fittings for Flared Copper Tube	ASME B 16.26
Cast Copper Alloy Pipe Flanges	ASME B 16.24
Pipe Flanges & Flanged Fittings	ASME B 16.5
Pipe Nipples for Brass and Copper	ASTM B 687
Push Fit Fittings (for use on PEX tubing complying with ASTM F 876 or F877, type K and L hard drawn and annealed copper tubing complying with ASTM B 88 and CPVC tubing complying with ASTM D 2846)	ASSE 1061
Seamless Brass Tube	ASTM B 135/B 135M
Seamless Copper Pipe	ASTM B 42
Seamless Copper Tube	ASTM B 75
Seamless Copper Water Tube (Types K & L	ASTM B 88

Table 603 Water Pipe and Fitting Materials	
Materials	Standards
only)	
Seamless Red Brass Pipe	ASTM B 43
Threadless Copper Pipe (TP)	ASTM B 302
Welded Brass Tube	ASTM B 587
Welded Copper Tube	ASTM B 447
Wrought-Copper and Copper Alloy Solder-Joint Pressure Fittings	ASME B 16.22, For Copper Water Tube
Wrought Seamless Copper and Copper-Alloy Tube	ASTM B 251
Valves-Flanged Threaded, and Welding End	ASME B 16.34

AUTHORITY NOTE: Promulgated in accordance with R.S. 40:4(A)(7) and R.S. 40:5(2)(3)(7)(9)(16)(17)(20).

HISTORICAL NOTE: Promulgated by the Department of Health and Hospitals, Office of Public Health, LR 38:2833 (November 2012).

### §605. Quality of Water Supply

A. Potable Water. Potable water shall be used for drinking, culinary, and domestic purposes.

B. Acceptable Sources. Where a public supply of potable water is not available, requirements satisfactory to the governing authority shall be observed.

C. Nonpotable Water. Nonpotable water shall not be supplied to any fixture customarily classified a plumbing fixture and may only be used to supply industrial equipment or other appliances which do not require a potable supply of water and provided such nonpotable water shall not be accessible for drinking, culinary or bathing purposes.

AUTHORITY NOTE: Promulgated in accordance with R.S. 40:4(A)(7) and R.S. 40:5(2)(3)(7)(9)(16)(17)(20).

HISTORICAL NOTE: Promulgated by the Department of Health and Hospitals, Office of Public Health, LR 38:2834 (November 2012).

### §607. Identification of Nonpotable Water

A. Color Code Identification. Piping and outlets conveying nonpotable water shall be adequately and durably identified by a distinctive yellow-colored paint so that it is readily distinguished from piping carrying potable water.

1. Exception. Reclaimed Water. Where reclaimed water is piped or used, piping and outlets conveying this particular type of nonpotable water shall be adequately and durably identified by a distinctive purple-colored paint (or, in lieu of paint, the purple color may be manufactured integral to the pipe) so that it is readily distinguished from piping carrying potable water. The color standard and color tolerances of the required purple-color should meet the American Public Works Association's Uniform Color Code, i.e., Pantone Matching System 253, which is further specified in ANSI Z535.1-2006 (R2011) and identified in the ANSI Z535-2011 color chart.)

2. In those instances when it is not feasible to paint the entire length of the nonpotable water pipe, each nonpotable pipe shall be minimally identified with the words

“caution: nonpotable water, - do not drink” in black lettering on a band of yellow-colored paint as background to designate that the liquid being conveyed therein is nonpotable. Such identification shall not be concealed by pipe insulation and when insulated the insulation shall be painted the same color as is required for the pipe. Maintenance of all identification shall be the responsibility of the owner. This identification shall be done in accordance with ASME A 13.1. The minimum size of the black letters and the length of the yellow-colored paint field shall conform to the requirements in Table 607.A.2 of this code.

Table 607.A.2 Minimum Length of Color Field and Size of Letters		
Outside Diameter of Pipe or Covering (Inches)	Minimum Length of Color Field (Inches)	Minimum Size of Letters (Inches)
1/2 to 1 1/4	8	1/2
1 1/2 to 2	8	3/4
2 1/2 to 6	12	1 1/4
8 to 10	24	2 1/2
Over 10	32	3 1/2

3. Within and about buildings and structures, a visible colored identification band shall be provided every 20 feet (6096 mm) but at least once per room, and the wording shall be visible in the normal line of vision from floor level. On straight pipe runs, the visible identification band shall be at intervals sufficient for identification. Arrows shall be used to indicate the direction of normal flow.

4. It is expressly understood that fire protection piping systems, downstream of the backflow preventer, is not considered plumbing, as per the definition of plumbing in Section 203 of this code. Nothing herein shall be construed to prevent, for example, fire protection piping from being painted a red color with white lettering. Likewise, other color combinations may be used for other specific applications in accord with ASME A 13.1.

B. Contents Identification. Where any type of nonpotable water is used, all valves, branch fittings and branch terminals shall be minimally identified by the words "caution: nonpotable water, - do not drink" in black lettering on a yellow background. This identification shall be done in accordance with ASME A 13.1. Besides the caution statement, the contents (i.e., the specific nonpotable liquid) may also be identified on the legend.

C. Overall Exception to this Section (§607 of this code). Pursuant to R.S. 40:4.12, industrial-type facilities listed therein shall not be required to comply with this section (§607 of this code) provided that such facilities have a potable water distribution identification plan in conformity with the requirements of R.S. 40:4.12. The required formal cross-connection control survey of the facility referenced in R.S. 40:4.12 shall be performed by an individual holding a valid cross-connection control surveyor certificate issued under the requirements of ASSE 5120, or other individuals holding a surveyor certificate from a nationally recognized backflow certification organization approved by the state health officer.

AUTHORITY NOTE: Promulgated in accordance with R.S. 30:2399, R.S. 40:4(A)(7) and R.S. 40:5(2)(3)(7)(9)(16)(17)(20).

HISTORICAL NOTE: Promulgated by the Department of Health and Hospitals, Office of Public Health, LR 38:2834 (November 2012).

**§609. Protection of Potable Water Supply**

A. Backflow and Back-Siphonage. The potable water supply including, but not limited to, the water supply system, the water service pipe, and the water distribution system shall be protected from backflow and back-siphonage in conformance with the following.

1. Backflow. The potable water supply including, but not limited to, the water supply system, the water service pipe, and the water distribution system shall be protected against backflow. Every water outlet shall be protected from backflow, preferably by having the outlet end from which the water flows spaced a distance above the flood-level rim of the receptacle into which the water flows sufficient to provide a "minimum required air gap (water distribution)" as defined in ASME A 112.1.2. Where it is not possible to provide a minimum air gap (water distribution), the water outlet shall be equipped with an accessible backflow preventer complying with §609.B of this code.

2. Back-Siphonage. Potable water supply piping, water discharge outlets, backflow prevention devices or similar equipment shall not be so located as to make possible their submergence in any contaminated or polluted liquid or substance.

B. Approval of Devices. Devices for the prevention of backflow or back-siphoning shall comply with the standards listed in Table 609 of this code below. Devices installed in a potable water supply for protection against backflow shall be maintained in good working condition by the person or persons having control of such devices. The plumbing official (or, for containment devices, the water supplier) may inspect such devices and, if they are found to be defective, inoperative, or the wrong application for the cross connection or potential cross connection involved, shall require the repair and/or replacement thereof. Any repair or replacement of a device shall require testing as required under §609.F.9.c of this code.

Table 609 Backflow Prevention Devices	
Materials	Standards
Backflow Preventers, Reduced Pressure Principle Assembly	ASSE 1013, AWWA C511
Field Test Procedures for Backflow Preventer Assemblies	ASSE Series 5000
Manual for the Selection, Installation, Maintenance and Field Testing of Backflow Prevention Devices	CAN/CSA-B64.10
Vacuum Breakers, Anti-Siphon, Pressure Type Assembly (Outdoor Use)	ASSE 1020
Vacuum Breakers-Atmospheric Type	ASSE 1001
Vacuum Breakers (Spill Resistant)	ASSE 1056
Vacuum Breakers, Hose Connection	ASSE 1011
Vacuum Breaker Wall Hydrants, Freeze Resistant Automatic Draining	ASSE 1019
Water Closet Anti-Siphon Fill Valves (Ballcocks)	ASSE 1002

C. Where Required. The following are certain instances wherein backflow prevention devices are required. This list shall not be construed as all instances where a backflow prevention device is required.

1. Flushometer. Flushometer valves shall be equipped with an approved vacuum breaker. The vacuum breaker shall be installed on the discharge side of the flushing valve with the critical level at least 4 inches (102 mm) above the overflow rim of the bowl. Flushometer tanks shall be provided with an approved backflow prevention device installed above the flood-level rim of the fixture.

2. Flush Tanks. Flush tanks shall be equipped with an approved ballcock. The ballcock shall be installed with the critical level of the vacuum breaker at least 1-inch (25.4 mm) above the full opening of the overflow pipe. In cases where the ballcock has no hush tube, the bottom of the water supply inlet shall be installed at least 1-inch (25.4 mm) above the full opening of the overflow pipe. A sheathed ballcock shall be installed on all gravity flush tanks in which the flush valve seat is less than 1-inch (25.4 mm) above the flood-level rim of the bowl.

3. Lawn Sprinklers and Irrigation Piping System. Lawn sprinkler systems and irrigation piping systems shall be equipped with an approved backflow preventer to protect against contamination of the potable water system. The following devices shall be acceptable.

a. Anti-siphon vacuum breakers, reduced pressure zone backflow preventers, and pressure type vacuum breakers equipped with gate or ball valves and test cocks. See §609.F of this code for acceptable types based upon the application.

b. Atmospheric type vacuum breakers shall be installed downstream of the last control valve at least 6 inches (152 mm) above the highest point of usage (i.e., 6 inches (152 mm) above all downstream piping and the highest sprinkler head).

c. All protective devices shall be installed in an accessible location to allow for inspection and maintenance

Table 609 Backflow Prevention Devices	
Materials	Standards
Air Gap Standards	ASME A112.1.2
Backflow Preventers for Beverage Dispensing Equipment	ASSE 1022
Backflow Preventers, Double Check Valve Assembly	ASSE 1015, AWWA C510
Backflow Preventers, Laboratory Faucet	ASSE 1035
Backflow Preventers with Intermediate Atmospheric Vent	ASSE 1012
Backflow Preventers, Double Check Detector Fire Protection Backflow Prevention Assemblies	ASSE 1048
Backflow Preventers, Hose Connection	ASSE 1052
Backflow Preventers, Reduced Pressure Detector Fire Protection Assemblies	ASSE 1047

and to isolate the sprinkler system from all other piping in the system.

d. Pressure type vacuum breakers shall be installed at least 12 inches (305 mm) above the highest point of usage (i.e., 12 inches (305 mm) above all downstream piping and the highest sprinkler head).

4. Fixture Valve Outlets with Hose Attachments, Hose Bibbs and Lawn Hydrants. Fixture valve outlets with hose attachments, hose bibbs, and lawn hydrants shall comply with the following.

a. Fixture valve outlets with hose attachments, hose bibbs and lawn hydrants shall be protected against backflow by an air gap (water distribution), a vacuum breaker or other approved back-siphonage backflow preventer on the discharge side of the valve. Back-siphonage backflow preventers may be installed directly on hose outlet connection threads. Vacuum breakers shall be installed at least 6 inches (152 mm) above the highest point of usage.

i. Exception. Water heater drains, boiler drains and washing machine connections shall not be required to be fitted with backflow prevention devices.

b. In areas subject to temperatures of 32°F (0°C) or below, all hose bibb vacuum breakers shall be of such design that the hydrant may be drained without removing the backflow preventer from the hydrant. Regardless of area temperature, hose bibb vacuum breakers shall be designed and installed to prevent total removal from the hose bibb after installation in accordance with the provisions of this code and the manufacturer's instructions.

5. Water Supply to Steam and Hot Water Heating Boilers, Heat Exchangers, Chilled Water Systems, etc. A backflow preventer device which will automatically vent to the atmosphere shall be installed in the water supply line to all steam and hot water space heating boilers, heat exchangers, chilled water systems and similar devices being supplied from the potable water system. Such devices shall prevent back-siphonage and backflow from the heating system into the potable supply lines should the supply pressure fall below the pressure in the heating system. Such devices shall meet the requirements of ASSE 1012 or 1013 and shall bear such identification as is required by the applicable standard. See §609.F of this code for acceptable types based upon the application.

6. Connections to automatic fire sprinkler systems shall be required to meet the minimum requirements as referenced in §609.F of this code.

7. Handheld Showers and Pull-out Spout Type Faucets. Handheld showers and pull-out spout type faucets with integral backflow protection shall comply with ASME A112.18.1, CSA B125.1, or ASME A112.18.3; or, in lieu thereof, shall require a dedicated deck or wall mounted vacuum breaker.

8. Portable Cleaning Equipment. Where the portable cleaning equipment connects to the water distribution system, the water distribution system shall be protected

against backflow with an air gap (water distribution), an atmospheric type vacuum breaker, a pressure type vacuum breaker or a reduced pressure principle backflow preventer. See §609.F of this code for acceptable types based upon the application.

9. Chemical Dispensers. Where chemical dispensers connect to the water distribution system, the water distribution system shall be protected against backflow with an air gap (water distribution), an atmospheric type vacuum breaker, a pressure type vacuum breaker or a reduced pressure principle backflow preventer. See §609.F of this code for acceptable types based upon the application.

10. Dental Pump Equipment. Where dental pumping equipment connects to the water distribution system, the water distribution system shall be protected against backflow with an air gap (water distribution), an atmospheric type vacuum breaker, a pressure type vacuum breaker or a reduced pressure principle backflow preventer. See §609.F of this code for acceptable types based upon the application.

D. Backflow Preventer Installation. Backflow preventers shall be installed in accord with the following.

1. Reduced pressure zone (RPZ) type backflow preventers, and other types of backflow preventers with atmospheric ports and/or test cocks (e.g., atmospheric type vacuum breakers, double check valve assemblies, pressure type vacuum breaker assemblies, etc.), shall not be installed below grade<sub>(G)</sub> (in vaults or pits) where the potential for a relief valve, an atmospheric port, or a test cock being submerged exists.

a. RPZ type backflow preventers and other types of backflow preventers having an atmospheric discharge port (e.g., backflow preventer with intermediate atmospheric vent) shall be installed such that the lowest point of the atmospheric discharge port's opening shall be a minimum of 12 inches above grade<sub>(G)</sub> or platform. When RPZ type backflow preventers and other types of backflow preventers with an atmospheric discharge port (e.g., backflow preventer with intermediate atmospheric vent) are installed in flood-prone areas, the lowest point of the atmospheric discharge port's opening should be installed at least 2-feet above the highest flood level which may have occurred in 10-year period, but in no case less than 2-feet above grade<sub>(G)</sub>.

b. For the purpose of maintenance, double check valve assembly type backflow preventers shall be installed a minimum of 12 inches above grade<sub>(G)</sub> or platform.

2. Pipe-applied atmospheric type vacuum breakers shall be installed not less than 6 inches (152 mm) above all downstream piping and not less than 6 inches (152 mm) above the flood-level rim of the fixture receptor or device served. Pipe-applied pressure type vacuum breakers shall be installed not less than 12 inches (305 mm) above all downstream piping and not less than 12 inches (305 mm) above the flood-level rim of the fixture receptor or device served. Approved deck-mounted vacuum breakers and vacuum breakers within equipment, machinery and fixtures, whether of the atmospheric or spill-proof pressure type,

where the critical level is a fixed distance above the potential source of contamination, shall be installed not less than 1-inch (25.4 mm) above the flood-level rim of the fixture receptor device served or source of contamination.

3. Access, Clearance, and Platform. Backflow preventer assemblies shall be installed in an accessible location to provide for the required testing, maintenance and repair. A minimum of 1-foot of clearance shall be provided between the lowest portion of the assembly and grade<sub>(g)</sub> or platform. Elevated installations exceeding 5-feet above grade<sub>(g)</sub> shall be provided with a suitably located permanent platform capable of supporting the general tester, licensed plumber, or any other person authorized in accordance with §§609.F.8 and 609.F.9 of this code to test or repair the assembly.

E. Reduced Pressure Zone Backflow Preventers. Reduced pressure zone backflow applications subject to periodic no flow conditions should include a single soft seated spring loaded check valve located immediately upstream of the backflow prevention device to prevent periodic relief valve activation caused by fluctuating supply pressures.

F. Additional Requirements to Protect the Potable Water Supply [formerly Appendix D - Cross Connection Control]. The following are additional, more specific requirements for the protection of the potable water supply including, but not limited to, the water supply system, the water service pipe, and the water distribution system. For other rules and regulations regarding potable water supply protection, see Part XII (Water Supplies) of the State Sanitary Code of Louisiana (LAC 51:XII).

1. Purpose. The purpose of this Subsection is to provide for the protection of the public from the possibility of contamination or pollution by isolating such contaminants or pollutants which could backflow or back-siphon into a potable water supply; to promote the elimination or control of existing cross-connections, actual or potential, between potable water supplies and non-potable systems/sources; and to promote the maintenance of a continuing program of cross-connection control in the State of Louisiana.

2. Definitions. Definitions contained in Chapter 2 shall also apply to this Subsection except where the following special definitions shall apply.

*Air Gap (Water Distribution)*—in a *water supply system* and/or a *water distribution system*, the unobstructed vertical distance through the free atmosphere between the lowest opening from any pipe or faucet supplying water to a tank, *plumbing fixture*, or other device and the *flood-level rim* of the receptacle.

*Atmospheric Vacuum Breaker*—a device which prevents *back-siphonage backflow* by creating an atmospheric vent when there is either a negative pressure or sub-atmospheric pressure in a *water supply system* and/or *water distribution system*.

*Backflow*—the flow of water or other liquids, mixtures, or substances into the distribution pipes of a

potable *water supply system* and/or *water distribution system* from any source other than its intended source. See *Back-Pressure Backflow* and *Back-Siphonage Backflow*.

*Back-Pressure Backflow*—a condition which occurs when the downstream pressure is higher than the supply pressure causing a reversal of the normal direction of flow.

*Backflow Preventer*—a mechanical device which prevents *backflow* of contaminants and pollutants into a potable water supply or distribution system by means of positive check members in addition to atmospheric ports.

*Backflow Prevention Assembly*—a testable *backflow preventer* which comes assembled from the manufacturer as a complete unit having approved test cocks with shut off valves installed on both the inlet and outlet sides of the *backflow preventer*.

*Backflow Prevention Device*—a non-testable backflow preventer.

*Back-Siphonage Backflow*—a reversal of the normal direction of flow in the pipeline due to a negative pressure (vacuum) being created in the supply line with the *backflow* source subject to atmospheric pressure.

*Barometric Loop*—a fabricated piping arrangement rising at least 35 feet at its topmost point above the highest *fixture* it supplies. It is utilized in water supply and distribution systems to protect against *back-siphonage backflow*.

*By-Pass*—any system of piping or other arrangement whereby the water may be diverted around any part or portion of a *water supply system*, *water distribution system* or water treatment facility including, but not limited to, around an installed *backflow preventer*.

*Commercial Dishwasher*—a mechanical dishwasher that is used in other than domestic applications.

*Containment*—a method of *backflow* prevention which requires a *backflow* prevention device or method on the *water service pipe* to isolate the customer from the *water main*.

*Contamination*—the introduction into water of microorganisms, chemicals, toxic substances, wastes or wastewater that makes the water unfit for its intended use.

*Cross Connection*—any connection or arrangement by means of which contaminants of any kind can be caused to enter the potable *water supply system* or *water distribution system*.

*Degree of Hazard*—an evaluation of the potential risk to public health if the public were to be exposed to contaminated water caused by an unprotected or inadequately protected cross connection.

*Double Check Valve Assembly*—an assembly of 2 independently operating spring loaded check valves, with tightly closing shut off valves on each side of the check valves, plus properly located test cocks for the testing of each check valve.



*Double Check Valve with Intermediate Atmospheric Vent*—a device having two spring loaded check valves separated by an atmospheric vent chamber.

*Dual Check Valve*—two spring loaded, independently operating check valves without tightly closing shut-off valves and test cocks. Generally employed immediately downstream of the water meter. Not an approved backflow prevention device.

*Fixture Isolation*—a method of backflow prevention in which a *backflow preventer* is located to correct a *cross-connection* at a fixture located within the premise itself [rather than locating a *backflow preventer* on the *water service pipe* (as is done under *containment*)].

*Hose Bibb Vacuum Breaker*—a device which is permanently attached to a hose bibb and which acts as an *atmospheric vacuum breaker*.

*Human Consumption*—the use of water by humans for drinking, cooking, bathing, showering, hand washing, dishwashing, or maintaining oral hygiene.

*Master Meter*—a water meter serving multiple residential dwelling units or multiple commercial units. Individual units may or may not be sub-metered.

*Potable Water*—water having bacteriological, physical, radiological and chemical qualities that make it safe and suitable for human consumption.

*Potable Water Supply*—a publicly owned or privately owned *water supply system* which purveys *potable water*.

*Pressure Vacuum Breaker*—a device containing one or two independently operated spring loaded check valves and an independently operated spring loaded air inlet valve located on the discharge side of the check or checks. The device includes tightly closing shut-off valves on each side of the check valves and properly located test cocks for the testing of the check valve(s).

*Public Water System*—a particular type of *water supply system* intended to provide *potable water* to the public having at least fifteen *service connections* or regularly serving an average of at least twenty-five individuals daily at least sixty days out of the year.

*Reduced Pressure Principle Backflow Preventer*—an assembly consisting of two independently operating approved check valves with an automatically operating differential relief valve located between the two check valves, tightly closing shut-off valves on each side of the check valves plus properly located test cocks for the testing of the check valves and relief valve.

*Service Connection*—water service pipe.

*Water Service Pipe*—the pipe from the *water main* and/or water meter, *water supply system* or other approved source of water supply, to the building or structure served.

*Water Supplier*—a *person* who owns or operates a *water supply system* including, but not limited to, a *person* who owns or operates a *public water system*.

*Water Supply System*—the system of pipes or other constructed conveyances, structures and facilities through which water is obtained, treated to make it *potable* (if necessary) and then distributed (with or without charge) for human consumption or other use.

3. Air Gaps (Water Distribution). The provision of air gaps (water distribution) shall be required for backflow prevention in any and all cases where such a measure is the most practical that can be employed. The "minimum required air gap (water distribution)" shall be in accord with ASME A 112.1.2.<sup>1</sup>

<sup>1</sup>For informational purposes only, ASME A 112.1.2 generally requires a minimum required air gap equal to two times the effective opening (or 3 times the effective opening if affected by a nearby wall). Compliance shall be strictly determined by the provisions contained within the standard itself.

4. Responsibility of Water Suppliers. As required by LAC 51:XII.344, each water supplier shall protect the water produced and distributed by its water supply system from potential contamination by ensuring compliance with the containment practices and maintenance/field testing requirements prescribed by this Part or as otherwise directed by the state health officer.

5. Containment Practices. Backflow prevention methods or devices shall be utilized as directed by the water supplier or plumbing official to isolate specific water supply system customers from the water supply system's mains when such action is deemed necessary to protect the water supply system against potential contamination caused by backflow of water from that part of the water system owned and maintained by the customer (e.g., the piping downstream of the water meter, if provided).

a. As a minimum, the following types of backflow prevention assemblies or methods shall be installed and maintained by water supply system customers immediately downstream of the water meter (if provided) or on the water service pipe prior to any branch line or connections serving the listed customer types and categories.

<b>Table 609.F.5 (Containment)</b>	
<b>Air Gap</b>	
1. Fire Protection/Sprinkler System utilizing non-potable water as an alternative or primary source of water	
<b>Reduced Pressure Principle Backflow Prevention Assembly</b>	
1. Hospitals, Out-Patient Surgical Facilities, Renal Dialysis Facilities, Veterinary Clinics	
2. Funeral Homes, Mortuaries	
3. Car Wash Systems	
4. Sewage Facilities	
5. Chemical or Petroleum Processing Plants	
6. Animal/Poultry Feedlots or Brooding Facilities	
7. Meat Processing Plants	
8. Metal Plating Plants	
9. Food Processing Plants, Beverage Processing Plants	
10. Fire Protection/Sprinkler Systems using antifreeze in such system (a detector type assembly is recommended on unmetered fire lines)	
11. Irrigation/Lawn Sprinkler Systems with Fertilizer Injection	
12. Marinas/Docks	
13. Radiator Shops	
14. Commercial Pesticide/Herbicide Application	
15. Photo/X-ray/Film Processing Laboratories	

<b>Table 609.F.5 (Containment)</b>	
16. Multiple Commercial Units served by a master meter	
17. Any type of occupancy type or any other facility having one or more Single-walled Heat Exchangers which uses any chemical, additive, or corrosion inhibitor, etc., in the heating or cooling medium	
18. Any type of occupancy type or any other facility having one or more Double-walled Heat Exchangers which use any chemical, additive, or corrosion inhibitor, etc., in the heating or cooling medium and which does not have a path to atmosphere with a readily visible discharge	
19. Premises where access/entry is prohibited	
<b>Pressure Vacuum Breaker Assembly/ Spill Resistant Vacuum Breaker Assembly</b>	
1. Irrigation/Lawn Sprinkler Systems	
<b>Double Check Valve Assembly</b>	
1. Fire Protection/Sprinkler Systems (a detector type double check valve assembly is recommended on unmetered fire lines)	
2. Two residential dwelling units served by a master meter, unless both units are located on a parcel or contiguous parcels of land having the same ownership and neither unit is used for commercial purposes. As used herein, the term "commercial purposes" means any use other than residential.	
3. Three or more residential dwelling units served by a master meter	
4. Multistoried Office/Commercial Buildings (over 3 floors)	
5. Jails, Prisons, and Other Places of Detention or Incarceration	

b. Other Containment Practices - Table 609.F.5 of this code above is not inclusive of all potential contamination sources which may need containment protection. For potential contamination sources not listed in this table, backflow prevention methods or devices shall be utilized in accordance with Table B1 of CAN/CSA B64.10-1994. When a potential contamination source and its associated backflow prevention method or device is not identified in Table 609.F.5 of this code above or Table B1 of CAN/CSA B64.10-1994, backflow prevention methods or devices shall be utilized:

- i. as directed by the plumbing official; or
- ii. as directed by the water supplier.

c. In cases of a discrepancy regarding the particular backflow prevention assembly or method required, the assembly or method providing the higher level of protection shall be required.

6. Fixture Isolation Practices. Water supply system customers shall provide and maintain backflow prevention methods or devices as directed by the plumbing official within that part of the water system owned and maintained by the customer (e.g., the piping downstream of the water meter, if provided, or downstream from any containment device) to protect the on-site users of the water system against potential contamination due to backflow.

a. As a minimum, the following types of backflow prevention devices, assemblies or methods shall be employed as appropriate for the following points of usage.

<b>Table 609.F.6<sup>1</sup> (Fixture Isolation)</b>	
<b>Air Gap</b>	
1. Cooling Towers	
2. Chemical Tanks.	
3. Commercial Dishwashers in commercial establishments	
4. Ornamental Fountains	
5. Swimming Pools, Spas, Hot Tubs (reduced pressure principle	

<b>Table 609.F.6<sup>1</sup> (Fixture Isolation)</b>	
backflow preventer also acceptable)	
6. Baptismal Fonts	
7. Animal Watering Troughs	
8. Agricultural Chemical Mixing Tanks	
9. Water Hauling Tanks	
<b>Reduced Pressure Principle Backflow Preventers</b>	
1. Commercial Boilers	
2. Air Conditioning, Chilled Water Systems	
3. Air Conditioning, Condenser Water Systems	
4. Pot-type Chemical Feeders	
5. Swimming Pools, Spas, Hot Tubs (air gap also acceptable)	
6. Irrigation/Lawn Sprinkler Systems with Fertilizer Injection	
7. Photo/X-ray/Film Processing Equipment	
8. Single-walled Heat Exchangers which use any chemical, additive, or corrosion inhibitor, etc., in the heating or cooling medium	
9. Double-walled Heat Exchangers which use any chemical, additive, or corrosion inhibitor, etc., in the heating or cooling medium and which does not have a path to atmosphere with a readily visible discharge	
10. Room(s) or other sub-units of a premise or facility receiving water where access is prohibited	
<b>Double Check Valve Assembly</b>	
1. Food Processing Steam Kettles	
2. Individual Travel Trailer Sites	
3. Single-walled Heat Exchangers which do not use any chemical, additive, or corrosion inhibitor, etc., in the heating or cooling medium	
4. Double-walled Heat Exchangers which do not use any chemical, additive, or corrosion inhibitor, etc., in the heating or cooling medium and which does not have a path to atmosphere with a readily visible discharge	
<b>Atmospheric or Pressure Vacuum Breakers</b>	
1. Laboratory and/or Medical Aspirators	
2. Flushing Rim Bedpan Washers	
3. Garbage Can Washers	
4. Laboratory or Other Sinks with threaded or serrated nozzles	
5. Flushometer Operated Fixtures	
6. Commercial Washing Machines	
7. Irrigation/Lawn Sprinkler Systems	
8. Hose Bibbs	
9. Commercial Dishwashers in commercial establishments	
<b>Pressure Vacuum Breakers/Spill Resistant Vacuum Breakers</b>	
1. Mortuary/Embalming Aspirators	
2. Irrigation/Lawn Sprinkler Systems with Separate Zones	

NOTES:

- 1. See Tables 1307.E and 1307.F of this code for fixture isolation practices in hospital plumbing systems.

b. Other Fixture Isolation Practices - Table 609.F.6 of this code above is not inclusive of all potential contamination sources which may need fixture isolation protection. For potential contamination sources not listed in this table, backflow prevention methods or devices shall be utilized in accordance with Table B1 of CAN/CSA B64.10-1994.

c. When a potential contamination source and its associated backflow prevention method or device is not identified in Table 609.F.6 of this code above or Table B1 of CAN/CSA B64.10-1994, backflow prevention methods or devices shall be utilized as directed by the plumbing official.

d. In cases of a discrepancy regarding the particular backflow prevention device or method required, the device offering the higher level of protection shall be installed. In contested cases, the co-state plumbing official (i.e., the state health officer) shall be consulted to issue a ruling on the

particular backflow prevention device or method required, if any.

7. Bypasses. All bypasses shall have the same level of backflow protection as the main water supply line.

8. Installation/Repair. Backflow preventers shall be installed and/or repaired by a State Plumbing Board of Louisiana (SPBLA)-licensed plumber who holds a SPBLA water supply protection specialist endorsement on his/her plumbing license pursuant to LSA - R.S. 37:1361 et seq. and its implementing regulations (LAC 46:LV.101 et seq.); or, for those backflow preventers located on public property or otherwise under the complete control of the water supplier (e.g., water meter and the piping upstream of the water meter, if provided), by a Backflow Prevention Assembly Repairer who meets the ASSE 5130 Professional Qualification Standard or other individuals holding a backflow prevention assembly repairer certificate from a nationally recognized backflow certification organization approved by the state health officer. Backflow preventers associated with a landscape irrigation system may be installed, tested, and repaired by a Horticulture Commission of Louisiana-licensed landscape irrigation contractor who holds a SPBLA-issued special water supply protection specialist endorsement in accord with R.S. 3:3808.P.

9. Maintenance/Field Testing. Backflow prevention assemblies and methods shall be checked and field tested by a Backflow Prevention Assembly Tester who meets ASSE 5110 Professional Qualification Standard, or other individuals holding a testing certificate from a nationally recognized backflow certification organization approved by the state health officer. Testing procedures shall be in accord with the requirements of §319.F of this code.

a. Types of Backflow Preventers to be Field Tested. The following types of backflow prevention assemblies and methods shall be checked and field tested in accordance with the frequency established in §609.F.9.c of this code:

- i. double check valve assemblies;
- ii. reduced pressure principle backflow prevention assemblies;
- iii. pressure vacuum breakers;
- iv. spill resistant vacuum breakers;
- v. air gaps (water distribution) on high hazard applications; and,
- vi. other backflow prevention devices as specified by the plumbing official or water supplier.

NOTE: It is recommended that other types of backflow prevention devices not listed here be visually checked periodically.

b. Any backflow preventer in §609.F.9.a of this code which is found defective shall be repaired by an individual meeting the qualifications specified in §609.F.8 of this code.

c. Frequency of Field Testing. The backflow prevention assemblies and methods specified in §609.F.9.a of this code shall be field tested:

- i. upon installation;
- ii. when cleaned, repaired, or overhauled;
- iii. when relocated;
- iv. annually;
- v. as required by the plumbing official; and,
- vi. as required by the water supplier for assemblies or methods providing containment protection for their water supply system.

d. Owner Responsibilities. The owner of the backflow prevention assemblies shall comply with the following:

i. It shall be the duty of the owner of the backflow prevention assembly to see that these tests are made in a timely manner in accord with the frequency of field testing specified in §609.F.9.c of this code and that devices which are found defective are repaired or replaced in accordance with §609.F.9.b of this code.

ii. The owner shall notify the plumbing official, and/or water supplier in advance when the tests are to be undertaken so that the plumbing official and/or water supplier may witness the tests if so desired.

iii. Upon completion, the owner of a containment assembly or method (see §609.F.5 of this code) shall provide records of such tests, repairs, overhauls, or replacements to the water supplier. Upon completion, the owner of a fixture isolation device, assembly, or method (see §609.F.6 of this code) shall provide records of such tests, repairs, overhauls, or replacements to the plumbing official. In addition, all records shall be kept by the owner of the backflow prevention device or method for at least 5 years and, upon specific request, shall be made available to the plumbing official, water supplier, and/or the state health officer.

iv. All tests, repairs, overhauls or replacements shall be at the expense of the owner of the backflow preventer.

AUTHORITY NOTE: Promulgated in accordance with R.S. 40:4(A)(7) and R.S. 40:5(2)(3)(7)(9)(16)(17)(20).

HISTORICAL NOTE: Promulgated by the Department of Health and Hospitals, Office of Public Health, LR 38:2835 (November 2012), amended LR 41:394 (February 2015).

### §611. Sizing of Water Distribution System

A. Minimum Sizes. The sizing of the water distribution system shall conform to good engineering practice (e.g., see §1805, Appendix B of this code). See §611.C of this code for the minimum required size of fixture branches and individual manifold distribution lines. See §611.D of this code for the minimum required size of fixture supplies and §611.E of this code for the minimum pressure required at fixture outlets.

B. Calculation of Sizes. When required by the plumbing official, the sizing of the water distribution system shall be calculated by a registered mechanical engineer or other acceptable authority.

C. Size of Fixture Branches and Manifold Individual Distribution Lines. The minimum size of fixture branches or manifold individual distribution lines shall be in accordance with the following Table 611.

Table 611 Minimum Size of Fixture Branches and Individual Manifold Distribution Lines		
Type of Fixture or Device	Fixture Branch Pipe Size (in.)	Individual Manifold Distribution Line Size (in.)
Bathtubs (60" x 32" and smaller)	1/2	1/2
Bathtubs (Larger than 60" x 32")	1/2	1/2
Combination Sink and Tray	1/2	1/2
Drinking Fountain	1/2	1/2
Dishwasher (Domestic)	1/2	1/2
Kitchen Sink, Residential	1/2	1/2
Kitchen Sink, Commercial	3/4	3/4
Lavatory	1/2	1/2
Laundry Tray 1, 2, or 3 Compartments	1/2	1/2 (1 Tray)
Wall Hydrants	1/2	1/2
Shower (Single Head)	1/2	1/2
Sinks (Service, Slop)	1/2	1/2
Sinks Flushing Rim	3/4	3/4
Urinal (Flush Tank)	1/2	1/2
Urinal (Direct Flush Valve)	3/4	3/4
Water Closet (Flushometer Valve Type)	1	1
Water Closet (Gravity or Flushometer Tank Type)	1/2	1/2
Hose Bibbs	1/2	1/2

1. For fixtures not listed in Table 611 of this code above, the minimum fixture branch or manifold individual distribution line may be made the same as for a comparable fixture.

D. Size of Fixture Supply. The fixture supply piping, tubing, or flexible connector shall be sized in accordance with the fixture manufacturer's recommendations but in no case shall the size interfere with the minimum fixture outlet discharge pressure requirements specified in §611.E of this code.

E. Minimum Pressure. Minimum fairly constant service pressure at the point of outlet discharge shall be not less than 8 psi (55.2 kPa) flowing for all fixtures except for direct flush valves, for which it shall be not less than 15 psi (103 kPa) flowing, and except where special equipment is used requiring higher pressure. In determining the minimum pressure, allowance shall be made for the pressure drop due to friction loss in the piping system during maximum demand periods as well as head, meter, and other losses in the system.

F. Auxiliary Pressure, Supplementary Tanks. If the residual pressure in the system is below the minimum allowable at the highest water outlet when the flow in the

system is at peak demand, an automatically controlled pressure tank or automatically controlled pump or gravity tank of sufficient capacity shall be installed. Its capacity shall be sufficient to supply sections of the building installation which are too high to be supplied directly from the water main.

G. Low Pressure Cutoff. When a booster pump is used on an auxiliary pressure system, there shall be installed a low-pressure (<15 psi gauge) cutoff on the booster pump to prevent the creation of negative pressures on the suction side of the water system. Other arrangements may be used if found adequate and if approved by the plumbing official.

1. Exception. In the case of fire pumps whose source of water is a potable water system, in lieu of a low-pressure cutoff, a low-suction throttling valve may be installed to sense the pressure in the water supply and automatically send a signal to a valve on the discharge side of the pump. This valve will not close all the way and it will not cutoff the fire pump, but it will modulate (open and close) to throttle back the discharge in an attempt to maintain a relatively constant pressure at the sensing location on the suction side of the pump. This allows the fire pump to keep sending water to the fire while the water supply pressure on the suction side of the pump recovers. Use of this valve protects against negative pressures being created in the potable water main when an uncontrolled fire pump is used. The valve body is to be located in between the pump discharge and discharge check valve with the sensing line connected to the suction side of the pump. The valve shall be set to prevent suction pressure from dropping below 15 psi.

H. Variable Street Pressures. When the street main has a wide fluctuation in pressure, the water distribution system shall be designed for minimum pressure available.

I. Hazard and Noise. Where water pressures are excessive or where required to eliminate water hammer or when deemed necessary by local authorities, approved engineered water hammer arresters or calculated air chambers shall be provided to safeguard the water distribution system against destructive water hammer hazard and noise.

1. Approved engineered mechanical water hammer arresters shall be sized and installed in accordance with PDI-WH201 or ASSE 1010. Where line water pressure exceeds 65 psi (448 kPa) in a water distribution system, the next larger size approved water hammer arrester shall be used. When water pressure exceeds 80 psi (552 kPa), a water pressure reducing valve shall be installed in accordance with §611.J of this code. Any approved engineered mechanical water hammer arrester shall have been tested by a recognized testing laboratory and certified to meet the requirements of the above standard.

2. Where calculated air chambers are installed, they shall be in an accessible place and each air chamber shall be provided with an accessible means for restoring the air in the event the chamber becomes waterlogged.

J. Water Pressure Reducing Valve or Regulators. The following shall apply relative to water pressure reducing valves or regulators.

1. Where water pressure within a building exceeds 80 psi (552 kPa) static, an approved water pressure regulator conforming to ASSE 1003 with strainer shall be installed to reduce the pressure in the building water distribution piping to 80 psi (552 kPa) static or less, whichever is consistent with good engineering practice. Exceptions to this requirement are service lines to sill cocks and outside hydrants, and main supply risers in tall buildings where pressure from the mains is reduced to 80 psi (552 kPa) or less at the fixture branches or at individual fixtures.

2. The delivery pressure variation shall not exceed 1 psi (6.895 kPa) for every 10 psi (69 kPa) pressure change in the inlet pressure. The reduced pressure fall-off from its no-flow setting shall not exceed 17 psi (117 kPa), and with a difference at this point of 50 psi (345 kPa) between the initial and this reduced flow pressure of 50 psi (345 kPa), the capacity shall be not less than that shown in Table 611.J of this code below.

Nominal Pipe Size (in.)	1/2	3/4	1	1 1/4	1 1/2	2
Average velocity through pipe (ft/s)	10.5	10.0	9.5	9.0	8.5	7.5
Flow(gpm)	9.95	16.65	25.0	42.0	54.8	77.5

3. An integral bypass check valve shall be capable of opening to permit a reverse flow of water through the reducing valve to prevent a buildup of system pressure by thermal expansion of the water with an increase of reduced pressure not exceeding 2 psi (13.8 kPa) above the prevailing initial pressure.

4. The valve shall be designed to remain open to permit uninterrupted water flow in case of valve failure.

5. All regulators and strainers must be so constructed and installed as to permit repair or removal of parts without breaking a pipeline or removing the valve and strainer from the pipeline.

6. Approved valves shall comply with ASSE 1003.

K. Manifold Water Distribution Systems. Manifold water distribution systems shall comply with the following.

1. Hot water and cold water manifolds shall be sized according to Table 611.K of this code below.

Nominal Size ID (Inches)	Velocity <sup>1</sup>	
	4 fps	8 fps
1/2	2	5
3/4	6	11
1	10	20
1 1/4	15	31
1 1/2	22	44

NOTES:

1. For velocity limitations use manufacturers' recommendations.
2. Total gpm is the demand of all outlets.

2. Individual distribution pipe size shall conform to Table 611 of this code or to good engineering practice (e.g., see §1805, Appendix B of this code).

3. Individual fixture shutoff valves shall be installed at the outlet for each fixture. If secondary shutoff valves are used at the manifold, they shall be identified for the fixture being supplied.

4. Piping bundles for manifold systems shall be supported in accordance with Chapter 3. Direction changes and bending radiuses shall be in accordance with manufacturer's recommendations.

AUTHORITY NOTE: Promulgated in accordance with R.S. 40:4(A)(7) and R.S. 40:5(2)(3)(7)(9)(16)(17)(20).

HISTORICAL NOTE: Promulgated by the Department of Health and Hospitals, Office of Public Health, LR 38:2840 (November 2012).

**§613. Water Service Pipe and Fittings**

Editor's Note: The text in this Section will be effective on January 1, 2013.

A. Materials Underground. Materials for underground water service pipe and lawn sprinkler systems, shall be a minimum Type L copper tube, brass, cast iron pressure pipe, ductile-iron, or pressure-rated plastic as listed in Table 603 of this code. The minimum working pressure of plastic piping installed outside of the foundation walls shall be 160 psi (1103 kPa) at 73°F (23° C), with permanent identification markings. All potable water pipes, pipe fittings, plumbing fittings, or fixtures for underground water service pipe shall be evaluated and listed as conforming to NSF/ANSI 372. Any solder or flux used in the installation or repair of any plumbing including, but not limited to, water service lines in a residential or nonresidential facility providing water for human consumption shall be lead free.

1. Exception. The lead free requirement of §613.A of this code above shall not apply to:

- a. leaded joints necessary for the repair of existing cast iron pipes;
- b. pipes, pipe fittings, plumbing fittings, or fixtures, including backflow preventers, that are used exclusively for nonpotable services such as manufacturing, industrial processing, irrigation, outdoor watering, or any other uses where the water is not anticipated to be used for human consumption; or,
- c. toilets, bidets, urinals, fill valves, flushometer valves, tub fillers, shower valves, service saddles, or water distribution main gate valves that are 2 inches in diameter or larger.

2. Materials subject to corrosion shall be protected when installed in corrosive soils. Approved fittings shall be used on the water service pipe and the water supply system, except that changes of direction in copper tube (ASTM B 88) may be made with bends having a radius of not less than

four diameters of the tube, providing that such bends are made by use of forming equipment which does not deform or create loss in cross-sectional area of the tube. If allowed by the manufacturer, bends of pressure-rated plastic pipe listed in Table 603 of this code shall be installed to conform with the manufacturer's recommendations but in no case shall the bend radius be less than the requirements contained within §§619.A.5 through 619.A.8, as applicable. With the exception of heat fused polypropylene, all other inaccessible water service joints and fittings for plastic pipe below concrete slabs and driveways are prohibited.

B. **Water Service Piping.** Water service lines shall be sized in accordance with accepted engineering practice (e.g., see §1805, Appendix B of this code), but in no case shall the water service piping be less than 1-inch inside nominal diameter for galvanized ferrous piping or 3/4-inch inside diameter for copper, copper alloy or approved noncorrosive pipe or tube.

C. **Service Lines Near Drain or Sewer Line.** Except as permitted in §613.D of this code, the underground water service pipe and the building drain or building sewer shall be not less than 5-feet (1524 mm) apart horizontally and shall be separated by undisturbed or compacted earth.

D. **Permitted Installation Near Drain or Sewer Line.** The water service pipe may be placed in the same trench with the building drain and building sewer provided the following conditions are met:

1. The bottom of the water service pipe, at all points, shall be at least 12 inches (305 mm) above the top of the sewer line at its highest point;

2. The water service pipe shall be placed on a solid shelf excavated at one side of the common trench; and,

3. Any underground water service pipe which must cross a pipe that conveys sewage (e.g., building drains, building sewers, and other piping conveying sewage) shall have a minimum vertical separation of 12 inches (305 mm) between the outside of the water service pipe and the outside of the sewer pipe. The water service pipe should always be installed above the sewer pipe. At crossings, one full length of water pipe shall be located so both joints will be as far from the sewer pipe as possible.

E. **Stop and Waste Valves and Devices.** Combination stop and waste valves and cocks shall not be installed underground in a water service pipe, water supply system, or a water distribution system. Any fixture or device which incorporates a stop and waste feature is prohibited if the waste opening is underground or in any location that waste water or water-borne contaminants may enter the device or water supply from the ground or other source by reversal of flow.

F. **Private Water Supply.** No private supply shall be interconnected with any public water supply.

G. **Potable Water (Pressure) Lines Near Soil Absorption Trenches, Sand Filter Beds, Oxidation Ponds, and any Effluent Reduction Option (Effluent Reduction Fields, Rock**

**Plant Filters, Spray Irrigation Systems, Overland Flow Systems, Mound Systems, or Subsurface Drip Disposal Systems).** Underground potable water (pressure) lines shall not be located within 25 feet (7.6 m) of any soil absorption trenches, sand filter beds, oxidation ponds, or any effluent reduction option [including, but not limited to effluent reduction fields, rock plant filters, spray irrigation systems (from the edge of the spray and its drainage), overland flow systems (from the discharge point and field of flow), mound systems, or subsurface drip disposal systems - see LAC 51:XIII.733] which have been installed for either the disposal of septic tank effluent or mechanical treatment plant effluent.

H. **Potable Water (Pressure) Lines Near Septic Tanks, Mechanical Sewage Treatment Plants, and Pump Stations.** Underground potable water (pressure) lines shall not be located within 10 feet (3.0 m) of any septic tank, mechanical sewage treatment plant, or sewage pump station.

I. **Potable Water (Pressure) Lines Near Seepage Pit, Cesspool, or Sanitary Pit Privy.** Underground potable water (pressure) lines shall not be located within 50 feet (15.2m) of any seepage pit, cesspool, or sanitary pit privy.

J. **Reclaimed Water Lines.** Reclaimed water lines shall be considered and treated as though they are sewerage lines and shall be installed in accord with the spacing requirements of this Section for the protection of potable water lines.

**AUTHORITY NOTE:** Promulgated in accordance with R.S. 30:2399, R.S. 40:4(A)(7), R.S. 40:5(2)(3)(7)(9)(16)(17)(20), and R.S. 40:1299.27.1.

**HISTORICAL NOTE:** Promulgated by the Department of Health and Hospitals, Office of Public Health, LR 38:2841 (November 2012).

### **§615. Water Pumping and Storage Equipment**

A. **Pumps and Other Appliances.** Water pumps, tanks, filters, softeners, and all other appliances and devices shall be protected against contamination.

B. **Drains from Pressure Tanks, Boilers, and Relief Valves.** The drains from pressure tanks, boilers, relief valves and similar equipment shall not be directly connected to the drainage system.

C. **Cleaning, Painting, Repairing Water Tanks.** A potable water supply tank shall not be lined, painted, or repaired with any material which will affect either the taste or the potability of the water supply when the tank is returned to service. Tanks shall be disconnected from the system during such operations, to prevent any foreign fluid or substance from entering the distribution piping.

D. **Insufficient Pressure.** When the water pressure from the water main (or other approved sources of potable water supply) during flow is insufficient to supply all fixtures freely and continuously, the rate of supply shall be supplemented by a gravity house tank or booster system (see §611.G of this code).

E. **Support.** All water supply tanks shall be supported in accordance with the applicable codes adopted under the

authority of Act 12 of the 2005 First Extraordinary Session or other regulations which apply.

F. **Overflow Pipes.** Overflow pipes for gravity tanks shall be protected against the entrance of insects and vermin and shall discharge above and within 6 inches (152 mm) of a roof or catch basin. Overflow pipes shall not be valved.

G. **Drains.** Water supply tanks shall be provided with valved drain lines located at their lowest point and discharged as an indirect waste. Drains for water supply tanks shall be not less than shown in Table 615.G of this code below.

Table 615.G Minimum Drain Size for Water Supply Tanks			
Drain Pipe (in)	Tank Capacity (gal)	Drain Pipe (in)	Tank Capacity (gal)
1	Up to 750	2 1/2	3001 to 5000
1 1/2	751 to 1500	3	5001 to 7500
2	1501 to 3000	4	Over 7500

1. Each drain line shall be equipped with a quick opening valve of the same diameter as the pipe.

H. **Gravity and Suction Tank.** Tanks used for potable water supply shall be equipped with tight covers which are vermin and rodent proof. Such tanks shall be vented with a return bend vent pipe having an area not less than one-half the area of the feed riser, and the vent opening shall be properly screened.

I. **Pressure Tank.** Pressure tanks used for supplying potable water shall be equipped with an approved vacuum relief device located on the top of the tank. The air inlet of this device shall be properly screened.

AUTHORITY NOTE: Promulgated in accordance with R.S. 40:4(A)(7) and R.S. 40:5(2)(3)(7)(9)(16)(17)(20).

HISTORICAL NOTE: Promulgated by the Department of Health and Hospitals, Office of Public Health, LR 38:2843 (November 2012).

**§617. Water Supply Control**

A. **Valves Required.** An accessible shutoff valve shall be provided on the consumer's premises ahead of the first outlet or branch connection to the service or distribution pipe of each dwelling, dwelling unit and buildings other than dwellings and dwelling units. Full port ball valve shut-offs on lines to 2 inches or full port ball or resilient wedge-type shut-off valves for 2 1/2-inch lines and larger shall be used. When such shutoff valve is located in the service pipe outside the building, it shall be located and accessible in a manufactured, approved, valve box with a readily removable access cover which extends to grade<sub>(G)</sub> level. When drain valves are provided for the distribution piping or other portions of the water distribution system, such drains shall be above grade<sub>(G)</sub> or otherwise located to prevent the possibility of backflow into the piping system after the system has been drained.

B. **Tank Controls.** Supply lines taken from pressure or gravity tanks shall be valved at or near the tank.

C. **Controls for Fixtures Within Dwellings and Dwelling Units.** Each individual fixture shall have an accessible shutoff valve at each outlet which will permit each fixture to be shut off without interfering with the water supply to any other fixtures. Shutoff valves for each fixture supplied by a manifold distribution system may be located at the manifold in addition to the outlet of the fixture being supplied. The hose bibb or hose connection shutoff valve shall be the only shutoff valve required on washing machine connectors.

1. Shutoff valves to water supply for refrigerators with automatic ice makers shall be accessible on the same floor.

D. **Controls for Fixtures in Buildings Other Than Dwellings or Dwelling Units.** In all buildings other than dwellings and dwelling units, shutoff valves shall be installed which permit the water supply to all fixtures and equipment in each separate room to be shut off without interference with the water supply to any other room or portion of the building or each individual fixture and piece of equipment shall have a shutoff valve which will permit each fixture and piece of equipment to be shut off without interfering with the water supply to other fixtures or equipment.

1. Each water supply branch line 1 1/2-inch or larger shall have a shutoff valve installed so as to isolate all fixtures and all pieces of equipment supplied by the branch line. The shutoff valve shall be installed in a labeled and accessible location as close to the connection to the supply main and/or riser as practical.

AUTHORITY NOTE: Promulgated in accordance with R.S. 40:4(A)(7) and R.S. 40:5(2)(3)(7)(9)(16)(17)(20).

HISTORICAL NOTE: Promulgated by the Department of Health and Hospitals, Office of Public Health, LR 38:2843 (November 2012).

**§619. Water Distribution Pipe, Tubing and Fittings**

Editor's Note: The text in this Section will be effective on January 1, 2013.

A. **General.** Water distribution pipe, tubing and fittings shall comply with the following.

1. Minimum working pressure for plastic hot and cold piping material installed inside of the foundation walls shall be 100 psi (689.5 kPa) at 180°F (82°C), with permanent identification markings.

2. Materials subject to corrosion shall be protected when installed in corrosive soils. Approved fittings shall be used on the water distribution system and the water supply system, except that changes of direction in copper tube (ASTM B 88) may be made with bends having a radius of not less than four diameters of the tube, providing that such bends are made by use of forming equipment which does not deform or create loss in cross-sectional area of the tube. If allowed by the manufacturer, bends of pressure-rated plastic pipe listed in Table 603 of this code shall be installed to conform with the manufacturer's recommendations but in no case shall the bend radius be less than the requirements contained within §§619.A.5 through 619.A.8 of this code, as applicable.

3. All potable water pipes, pipe fittings, plumbing fittings, or fixtures for the water distribution system shall be evaluated and listed as conforming to NSF/ANSI 372. Any solder or flux which is used in the installation or repair of any plumbing including, but not limited to, water distribution pipes in a residential or nonresidential facility providing water for human consumption shall be lead free.

a. Exception. The lead free requirement of §619.A.3 of this code above shall not apply to:

i. leaded joints necessary for the repair of existing cast iron pipes;

ii. pipes, pipe fittings, plumbing fittings, or fixtures, including backflow preventers, that are used exclusively for nonpotable services such as manufacturing, industrial processing, irrigation, outdoor watering, or any other uses where the water is not anticipated to be used for human consumption; or,

iii. toilets, bidets, urinals, fill valves, flushometer valves, tub fillers, shower valves, service saddles, or water distribution main gate valves that are 2 inches in diameter or larger.

4. All pipes and pipe fittings shall conform to the standards listed in Table 603 of this code. All solder and flux shall conform to the applicable standard(s) listed in Table 303 of this code.

5. Bends of cross-linked polyethylene (PEX) plastic tubing shall be installed to conform to the manufacturer's recommendations but in no case shall the bend radius be less than the following:

a. When bent with the coil-a bending radius equivalent to or greater than 8 times the outside diameter of the tubing shall be maintained. Outside diameter is equal to the inside nominal diameter plus 1/8-inch.

b. When bent against the coil-a bending radius equivalent to or greater than 24 times the outside diameter of the tubing shall be maintained. Outside diameter is equal to the inside nominal diameter plus 1/8-inch.

6. Because the linear expansion rate for cross-linked polyethylene (PEX) tubing is about 1 inch/10°F for each 100 feet (30 m) of tubing, it should not be rigidly anchored to any support in order to allow for freedom of movement during expansion and contraction. When installing long runs of tubing, a longitudinal clearance of 1/8 to 3/16 inch per foot of run should be allowed to accommodate for thermal expansion. PEX tubing, where it passes through concrete or a similar building material which would not allow for freedom of linear expansion, shall be provided with a pipe sleeve of Schedule 40 pipe which shall be built into the foundation, footing, floor, wall or ceiling. Such pipe sleeve shall be of sufficient inside diameter to allow for the free expansion and contraction of the PEX tubing and to prevent any rubbing action.

7. The maximum recommended spacing between horizontal supports for cross-linked polyethylene (PEX) tubing is 32 inches (813 mm) for nominal tubing diameters

from 1/4- inch through 2-inch. It should not be rigidly secured to a joist or stud but should be secured with smooth plastic strap hangers, which permit ease of movement during expansion or contraction. Valve and fixture connections to which PEX pipe is connected shall be rigidly anchored.

8. Bends of chlorinated polyvinyl chloride (CPVC) plastic pipe shall be installed to conform to the manufacturer's recommendations but in no case shall the bend radius be less than the following:

a. A bending radius equivalent to or greater than 18 inches (457 mm) for 1/2 and 3/4-inch inside nominal diameter piping.

b. A bending radius equivalent to or greater than 24 inches (610 mm) for 1-inch inside nominal diameter piping.

B. Materials Above Ground. Materials for water distribution pipes and tubing shall be brass, copper water tube minimum type L (i.e., type M copper is prohibited), stainless steel water pipe or tubing (Types 304/304L and 316/316L only), cast iron pressure pipe, ductile-iron, galvanized steel, pressure-rated polypropylene (PP), chlorinated polyvinyl chloride (CPVC) or cross-linked polyethylene (PEX) plastic pipe or tubing, all to be installed with approved fittings and bends; except that changes in direction in copper tube (ASTM B 88) may be made with bends having a radius of not less than four diameters of the tube, providing that such bends are made by use of forming equipment which does not deform or create a loss in cross-sectional area of the tube. Translucent PEX plastic pipe or tubing, when installed above ground, shall not be exposed to direct or indirect sunlight.

C. Materials Below Ground. Inaccessible water distribution piping under slabs shall be copper water tube minimum type L (i.e., type M copper is prohibited), brass, stainless steel water pipe (types 304/304L and 316/316L only), cast iron pressure pipe, ductile-iron pipe, chlorinated polyvinyl chloride (CPVC), pressure-rated polypropylene (PP) or cross-linked polyethylene (PEX) plastic pipe or tubing, all to be installed with approved joining methods or bends. All copper, brass and stainless steel joints below a building slab shall be brazed and/or welded in accordance with §315.D and §§621.D through 621.G of this code, as appropriate. Heat fused joints for polypropylene shall be made in accordance with §621.E.3 of this code. With the exception of heat fused polypropylene, all other joints and fittings for plastic pipe below a building slab are prohibited. Any material subject to corrosion shall be protected when used in corrosive soils.

D. Valves. Valves shall conform to the standards listed in Table 619.D of this code below.

<b>Materials</b>	<b>Standards</b>
Valves, Bronze Gate, Globe, Angle, Check	MSS SP-80
Valves, Cast Iron	ASTM A 126
Valves, Ball	MSS SP-72. MSS SP-110
Valves, Resilient-Seated Gate	AWWA C509



AUTHORITY NOTE: Promulgated in accordance with R.S. 40:4(A)(7), R.S. 40:5(2)(3)(7)(9)(16)(17)(20), and R.S. 40:1299.27.1.

HISTORICAL NOTE: Promulgated by the Department of Health and Hospitals, Office of Public Health, LR 38:2843 (November 2012).

## §621. Joints

Editor's Note: The text in this Section will be effective on January 1, 2013.

A. General. This Section contains provisions applicable to joints specifically for water service and distribution piping. Provisions for those joining methods which are applicable to more than one piping system are contained in Chapter 3 of this code.

B. Soldered Joints. Soldered joints for tubing shall be made with approved fittings (see §621.F of this code). Surfaces to be soldered shall be cleaned bright, all burrs shall be removed and the tubing shall be returned to full bore. The joints shall be properly fluxed and made with approved solder (see Table 303 of this code). All solder and flux used in the installation or repair of water supply systems, water distribution systems, and water service pipe shall be lead free. Soldered joints should not be made closer than 18 inches (457 mm) to an installed plastic-to-metal adapter in the same water line.

1. Exception. The lead free requirement of §621.B of this code above shall not apply to:

a. leaded joints necessary for the repair of existing cast iron pipes;

b. pipes, pipe fittings, plumbing fittings, or fixtures, including backflow preventers, that are used exclusively for nonpotable services such as manufacturing, industrial processing, irrigation, outdoor watering, or any other uses where the water is not anticipated to be used for human consumption; or

c. toilets, bidets, urinals, fill valves, flushometer valves, tub fillers, shower valves, service saddles, or water distribution main gate valves that are 2 inches in diameter or larger.

C. Flared Joints. Flared joints for soft tempered copper water tube shall be made with fittings meeting approved standards. The tubing shall be expanded with a proper flaring tool.

D. Brazed Joints. Brazed joints shall be made in accordance with the provisions of Section 6 of ANSI B31.1. Brazed joints should not be made closer than 18 inches (457 mm) to an installed plastic-to-metal adapter in the same water line.

E. Joints for Plastic Water Service and Water Distribution Pipe and Fittings. Joints for plastic water service and water distribution pipe and fittings shall comply with the following.

1. General. Plastic pipe and fittings for water service piping and water distribution piping may be of the insert type, compression type, solvent cemented (see Table 303 and

Section 313.H.1 of this code), heat fused, pressure-lock, or may be hot or cold flared as recommended by the manufacturer or the Plastic Pipe Institute for the particular materials being used. With the exception of heat fused polypropylene, all other joints and fittings for plastic pipe are prohibited on inaccessible water distribution piping under slabs.

2. Polyethylene Water Service. Stiffener inserts used with compression type fittings shall not extend beyond the clamp or nut of the fitting. Pipe shall be cut square, using a cutter designed for plastic pipe and ends shall be chamfered to remove sharp edges. Electro and heat fusion joints for Polyethylene pipe and fittings shall be made in accordance with ASTM F 1290 and ASTM F 2620, respectively. Flared joints shall be permitted where recommended by the manufacturer and made by the use of a tool designed for that operation.

3. Polypropylene Piping and Joints. Heat fused joints for polypropylene pipe and fitting joints shall be made in accordance with ASTM D 2657.

F. Copper Water Pipe and Tubing Joints for copper water pipe and tubing shall be formed either by the appropriate use of approved brass, bronze or wrought copper water fittings, properly soldered or brazed together, or by means of approved flare fittings as provided in §621.C of this code.

G. Stainless Steel Pipe and Joints. Joints and fittings for stainless steel pipe shall be installed in accordance with the manufacturer's installation instructions and approved standards. Welded joints shall be either fusion or resistance welded based on the selection of the base metal. Chemical composition of the filler metal shall comply with AWS A5.9 based on the alloy content of the piping material.

H. Special Joints. The special joints identified below shall comply with the following.

1. Copper Water Tubing or Stainless Steel Tubing to Threaded Pipe Joints. Joints from copper water tubing or stainless steel tubing to threaded pipe shall be formed by the use of bronze or copper adapter fittings. The joint between the copper tube or stainless steel tube and fittings shall be properly soldered or brazed, and the connection between the threaded pipe and the fitting shall be made with a standard pipe size threaded joint.

2. Ground Joint Brass Connections. Ground joint brass connections which allow adjustment of tubing but provide a rigid joint when made up shall not be considered as slip joints.

3. Plastic Pipe to Other Materials. Joints between plastic pipe and other materials shall be formed with proper adaption fittings as furnished by the manufacturer.

4. Unions. Unions in the water service pipe and water distribution system shall be metal-to-metal with ground seats.

AUTHORITY NOTE: Promulgated in accordance with R.S. 40:4(A)(7) R.S. 40:5(2)(3)(7)(9)(16)(17)(20), and R.S. 40:1299.27.1.

HISTORICAL NOTE: Promulgated by the Department of Health and Hospitals, Office of Public Health, LR 38:2845 (November 2012).

**§623. Safety Devices**

**A. Shower Temperature Control Devices.**

1. Multiple (gang) Showers. Multiple (gang) showers, when supplied by a single temperature controlled water supply pipe, shall be controlled by a master temperature actuated mixing valve conforming to ASSE 1069, or each shower shall be individually controlled by an automatic compensating scald preventative valve of the pressure balancing, thermostatic or combination pressure balance/thermostatic mixing valve type conforming to ASSE 1016, ASME A 112.18.1 or CSA B125.1. Handle position stops or other limit setting devices shall be provided on such valves and shall be adjusted in accordance with manufacturer's instructions at time of installation to deliver a maximum mixed water outlet temperature of 120°F (48.3° C).

2. Individual Shower and Shower/Bath Combinations. Shower and shower/bath combinations in all buildings shall be provided with an automatic compensating scald preventative valve of the pressure balance, thermostatic, or combination pressure balance/thermostatic mixing valve type which provides scald and thermal shock protection for the rated flow rate of the installed showerhead. These valves shall conform to ASSE 1016, ASME A 112.18.1 or CSA B125.1 and shall be equipped with a means to limit the maximum setting of the valve to 120°F (48.3°C), which shall be field adjusted in accordance with the manufacturer's instructions at the time of installation.

B. Public Lavatory Temperature Control Devices. The temperature of the water delivered from public use lavatories or other public hand-washing fixtures shall be limited to a maximum temperature of 120°F (48.3° C) by a temperature control device that conforms to ASSE 1070.

C. Bathtub and Whirlpool Temperature Control Devices. The temperature of the water delivered from bathtubs and whirlpools shall be limited to a maximum temperature of 120°F (48.3° C) by a temperature control device that conforms to ASSE 1070, except where such protection is otherwise provided for in accordance with §623.A of this code.

D. Thermal Expansion Control. Thermal expansion shall be controlled in accord with the following requirements.

1. If water is heated and stored in a consumer's system and the system has been closed by the installation of a backflow preventer or a pressure reducing valve, a thermal expansion control shall be installed at an accessible location between the checking device and the water heating equipment to limit thermal expansion of the water being heated to not more than 80 psi (552 kPa) static pressure at any fixture on the system. A potable water expansion tank or auxiliary relief valve set at 80 psi (552 kPa) shall be acceptable.

2. The auxiliary relief valve shall be in addition to the water heater safety relief valve. This thermal expansion control device shall be designed and trimmed for repeated operation. The valve shall be a minimum 1/2-inch pipe size, shall be adjustable and calibrated, and shall include a tag describing its function.

AUTHORITY NOTE: Promulgated in accordance with R.S. 40:4(A)(7) and R.S. 40:5(2)(3)(7)(9)(16)(17)(20).

HISTORICAL NOTE: Promulgated by the Department of Health and Hospitals, Office of Public Health, LR 38:2845 (November 2012).

**§625. Miscellaneous**

A. Drain Cock. All storage tanks shall be equipped with adequate drain cocks.

B. Line Valves. Valves in the water supply distribution system, except those immediately controlling one fixture supply, when fully opened shall have a cross-sectional area at the smallest orifice or opening through which the water flows at least equal to the cross-sectional area of the nominal size of the pipe in which the valve is installed.

C. Water Used for Processing. Water used for cooling of equipment or similar purposes shall not be returned to the potable water distribution system, water service pipe, or water supply system. When discharged to the building drainage system or other point of disposal, the waste water shall be discharged through an air gap (water distribution).

D. Trap Primers Connected Directly to a Potable Water System. Trap primers which connect directly to a potable water system shall comply with the following.

1. Trap primers which are connected directly to a potable water system shall be constructed with integral air gaps. In addition to the integral air gap, additional backflow protection shall be provided by the installation of either an approved air gap device on the discharge line from each trap primer, or by the installation of an approved reduced pressure principle backflow preventer on the trap primer's individual potable water supply line.

2. Trap primers (and associated air gap device and/or reduced pressure principle backflow preventer) shall be accessible and shall not be concealed by building or other construction.

3. Trap primer drains shall be constructed to completely drain by gravity after each cycle of operation

Table 623 Temperature Control Device Standards	
Materials	Standards
Automatic Compensating Valves for Individual Shower and Tub-Shower Combinations	ASSE 1016
Temperature Actuated Mixing Valves for Hot Water Distribution Systems	ASSE 1017
Automatic Temperature Control Mixing Valves	ASSE 1069
Water Temperature Limiting Devices	ASSE 1070
Plumbing Supply Fittings	ASME A112.18.1, CSA B125.1

and, in no case, shall the drain be connected to the trap below the top of the trap water seal or trap outlet weir.

4. Trap primer air gaps, when required, shall be located a minimum of 6 inches (152 mm) above the flood level of the floor drain or receptor served.

5. Trap primers which connect to the potable water system shall be connected to the cold water supply in accordance with the manufacturer's recommendations.

6. Separate cutoff valves shall not be installed between a trap primer and its water supply except that a cutoff valve for an individual fixture shall control both the water supply to the trap primer and the individual fixture to assure a constant supply to the primer.

AUTHORITY NOTE: Promulgated in accordance with R.S. 40:4(A)(7) and R.S. 40:5(2)(3)(7)(9)(16)(17)(20).

HISTORICAL NOTE: Promulgated by the Department of Health and Hospitals, Office of Public Health, LR 38:2846 (November 2012).

### **§627. Water Treatment Units**

A. Drinking water treatment units shall meet the requirements of NSF 42 and 53. Units are designed to be used for the reduction of specific contaminants from potable drinking water, such contaminants being considered as potential health hazards or affecting the aesthetic quality characteristics of potable drinking water.

B. Reverse osmosis drinking water treatment systems shall meet the requirements of NSF 58. Systems are designed to be used for the reduction of specific contaminants from potable drinking water supplies considered to be microbiologically safe and of known quality (except that claims for the reduction of filterable cysts may be permitted). Systems covered by this standard are intended for reduction of total dissolved solids (TDS) and other contaminants specified therein.

C. Waste and discharge from reverse osmosis or other types of water treatment units shall enter the drainage system through an air gap (drainage system).

AUTHORITY NOTE: Promulgated in accordance with R.S. 40:4(A)(7) and R.S. 40:5(2)(3)(7)(9)(16)(17)(20).

HISTORICAL NOTE: Promulgated by the Department of Health and Hospitals, Office of Public Health, LR 38:2846 (November 2012).

### **§629. Additional Water Supply and Distribution Provisions**

A. Additional provisions for water supply and distribution are found in the following:

1. LAC 51:XIV.609.F, Cross-Connection Control;
2. LAC 51:XIV.Chapter 13, Medical Facilities Plumbing Systems;
3. LAC 51:XIV.Chapter 15, Travel Trailers and Travel Trailer Parks;
4. LAC 51:XIV.Chapter 16, Mobile/Manufactured Homes and Mobile/Manufactured Home Parks; and,

5. LAC 51:XIV.1805, Appendix B, Sizing of Water Piping System.

AUTHORITY NOTE: Promulgated in accordance with R.S. 40:4(A)(7) and R.S. 40:5(2)(3)(7)(9)(16)(17)(20).

HISTORICAL NOTE: Promulgated by the Department of Health and Hospitals, Office of Public Health, LR 38:2847 (November 2012).

## **Chapter 7. Sanitary Drainage**

### **§701. General**

A. Scope. The provisions of this Chapter shall govern the materials, design, construction, and installation of sanitary drainage systems.

B. Damage to Drainage System, Sewerage System, or Sewage-Treatment Plant. Wastes which are detrimental to, and/or able to cause damage or operational problems to, either the drainage system, the sewerage system, or the functioning of the sewage-treatment plant shall be treated and disposed of in accordance with §703.F, §1005, or an approved pretreatment system as directed by the plumbing official.

C. Individual Sewerage System. Where a community sewerage system is not available, an individual sewerage system shall be of a type that is acceptable and approved by the state health officer. See Chapter 17 of this code.

D. Tests. The sanitary drainage system shall be tested in accordance with §319 of this code.

E. Engineered Systems. Engineered sanitary drainage and venting systems shall conform to the provisions of Chapter 12 of this code.

AUTHORITY NOTE: Promulgated in accordance with R.S. 40:4(A)(7) and R.S. 40:5(2)(3)(7)(9)(16)(17)(20).

HISTORICAL NOTE: Promulgated by the Department of Health and Hospitals, Office of Public Health, LR 38:2847 (November 2012).

### **§703. Materials**

A. General. Pipe, tubing, and fittings for drainage systems shall conform to the standards listed in Table 703 of this code.

B. Specific Type. Standards listed in Table 703 of this code below apply to the specific materials approved for use and, as indicated in the various Sections in this Chapter, as they apply to the drainage system.

C. Aboveground Piping within Buildings and Piping in Raceways or Tunnels. Aboveground piping within buildings and piping in raceways or tunnels shall comply with the following.

1. Soil and waste piping for drainage systems shall be of cast iron, galvanized steel, type 304 or 316L stainless steel, brass or copper pipe, type DWV copper tube, Schedule 40 plastic piping or borosilicate glass.

2. Vertical soil, waste and vent stacks shall be designed to control expansion and contraction, in accordance

with accepted engineering practice, to the satisfaction of the plumbing official.

D. Underground Piping Within Buildings. All underground drains within buildings shall be cast iron soil pipe, type 316L stainless steel, ductile-iron pipe, type DWV copper, heavy schedule borosilicate glass, or Schedule 40 plastic piping. Materials subject to corrosion shall be protected when installed in corrosive soils.

Table 703 Drainage System Materials	
Materials	Standards
<b>Nonmetallic Piping</b>	
Clay Drain Tile	ASTM C 4
Clay Pipe Compression Joints	ASTM C 425
Clay Sewer Pipe	ASTM C 700, Markings shall include ASTM number
Concrete Drain Tile	ASTM C 412/C 412M
Concrete Perforated Pipe	ASTM C 444/C 444M
Concrete Reinforced Culverts	ASTM C 76/C 76M, For storm drains only
Concrete Reinforced Sewer Pipe	ASTM C 361/C 361M, For storm drains only
Concrete Non-reinforced Sewer Pipe	ASTM C 14, For storm drains only
Sewer Manholes Precast Reinforced	ASTM C 478/C 478M
Concrete (Steel Cylinder Type)	FSS-P-381
<b>Plastic Pipe and Fittings</b>	
ABS-DWV Pipe and Fittings	ASTM D 2661, Listed, See §303.H.2 of this code
ABS Sewer Pipe and Fittings (for outside building sewers, storm drains and storm sewers)	ASTM D 2751, See §§705.A, 1101.E, 1103.B, and 1103.D of this code (Installation: ASTM D 2321)
Acrylonitrile-Butadiene-Styrene (ABS) Schedule 40 Plastic Drain Waste, and Vent Pipe with a Cellular Core	ASTM F 628, Listed
Chlorinated Poly (Vinyl Chloride) (CPVC) Pipe and Fittings for Chemical Waste Drainage Systems	ASTM F 2618
Coextruded Composite Pipe	ASTM F 1488, See §§303.H.2, 303.H.4, 705.A, 1101.E, and 1103.B, 1103.D of this code
Coextruded Composite Drain, Waste, and Vent Pipe (DWV)	ASTM F 1499, See §§303.H.2, 303.H.4, 705.A, 1101.E, 1103.B, and 1103.D of this code
Coextruded PVC Plastic Pipe with a Cellular Core	ASTM F 891, See §§303.H.2, 303.H.4, 705.A, 1101.E, 1103.B, and 1103.D of this code
Flexible Elastomeric Non-Pressure Joints	ASTM D 3212, See §303.H of this code
Large Diameter Ribbed PVC Sewer Pipe and Fittings	CAN/CSA-B182.4
Polyolefin Pipe and Fittings for Corrosive Waste Drainage Systems	ASTM F 1412
Polyvinylidene Fluoride (PVDF) Corrosive Waste Drainage Systems	ASTM F1673
PVC-DWV Pipe and Fittings	ASTM D 2665, Listed, See §303.H.2 of this code
ABS and PVC Plastic Tube and Tubular Fittings	ASTM F 409
Type PSM PVC Sewer Pipe & Fittings (for outside building sewers, storm drains and storm sewers)	ASTM D 3034, See §705.A, 1101.E, 1103.B, and 1103.D of this code (Installation: ASTM D 2321)
Type PSP PVC Sewer Pipe & Fittings (for outside building sewers, storm drains and storm sewers)	ASTM D 2321, Installation

Table 703 Drainage System Materials	
Materials	Standards
<b>Ferrous Pipe and Fittings</b>	
Cast Iron Soil Pipe and Fittings	ASTM A 74, CISPI HS
Cast Iron Hubless Pipe and Fittings	CISPI Std. 301, ASTM A 888
Ductile-Iron Gravity Sewer Pipe	ASTM A 746
Hubless Cast Iron Sanitary System	CISPI Std. 310
Manhole Top Frames and Covers	ASTM A 48/A 48M
Stainless Steel Drainage Systems for Sanitary DWV, Storm, and Vacuum Applications, Above- and Below Ground (Type 304 is prohibited from underground use in these drainage systems)	ASME A112.3.1
<b>Nonferrous Pipe and Fittings</b>	
Cast Copper Alloy Solder-Joint Drainage Fittings DWV	ASME B 16.23
Cast Copper Alloy Solder Joint Fittings for Solvent Drainage Systems	ANSI B 16.32
Copper Drainage Tube DWV	ASTM B 306
Corrosion-Resistant High-Silicon Iron Castings	ASTM A 518/A 518M
Lead Pipe, Bends and Traps	FS WW-P-325
Welded Copper and Copper Alloy Heat Exchanger Tube	ASTM B 543
Wrought Copper and Wrought Copper Alloy Solder-Joint Drainage Fittings For Plumbing Drainage Waste and Vents	ASME B 16.29
Wrought Copper and Copper Alloy Solder-Joint Fittings for Solvent Drainage Systems	ANSI B 16.43
<b>Glass Pipe</b>	
Borosilicate Glass Pipe and Fittings for DWV Applications	ASTM C 1053

E. Fittings. Fittings on the drainage system shall be compatible to the type of piping used. Fittings on threaded pipe shall be of the recessed drainage type. See §311 of this code.

F. Acid Soil and Waste Piping. Acid soil and waste piping for drainage systems shall be of a high silicon cast iron complying with ASTM A 518/A 518M, borosilicate glass complying with ASTM C 1053, chlorinated poly (vinyl chloride) (CPVC) complying with ASTM F 2618, polyolefin pipe complying with ASTM F 1412, polyvinylidene fluoride (PVDF) complying with ASTM F 1673, or other materials approved by the plumbing official. Joints shall be made in conformance with the manufacturer's recommendations. Acid soil, waste and vent piping shall not be connected to the conventional plumbing system.

1. Neutralizing Device. In no case shall corrosive liquids, spent acids, or other harmful chemicals which might destroy or injure a drain, sewer, soil or waste pipe, or which might create noxious or toxic fumes, discharge into the plumbing system without being thoroughly diluted or neutralized by passing through a properly constructed and acceptable dilution or neutralizing device (generally, utilizing limestone chips). Such device shall be automatically provided with a sufficient intake of diluting water or neutralizing medium, so as to make its contents

noninjurious before being discharged into the soil or sewage system.

AUTHORITY NOTE: Promulgated in accordance with R.S. 40:4(A)(7) and R.S. 40:5(2)(3)(7)(9)(16)(17)(20).

HISTORICAL NOTE: Promulgated by the Department of Health and Hospitals, Office of Public Health, LR 38:2847 (November 2012).

#### §705. Building Sewer

A. Separate Trenches. The building sewer, when installed in a separate trench from the water service pipe, shall be cast iron sewer pipe, vitrified clay sewer pipe, or plastic piping (minimum SDR 35 or heavier). Joints shall be watertight and rustproof and all material shall be installed according to the manufacturer's recommendations (see §705.H of this code). All pipe and fittings shall bear the manufacturer's name or trademark.

B. Sewer in Filled Ground. A building sewer or building drain installed in unstable fill or unstable ground shall be of cast iron pipe, except that nonmetallic drains may be laid upon an approved continuous supporting system if installed in accordance with §705.A of this code.

C. Sanitary and Storm Sewers. Where separate systems of sanitary drainage and storm drainage are installed in the same property, the sanitary and storm building sewers or drains may be laid side by side in one trench.

D. Old House Sewers and Drains. Old building sewers and building drains may be used in connection with new building or new plumbing and drainage work only when they are found, on examination and test, to conform in all respects to the requirements governing new house sewers. The plumbing official shall notify the owner to make the changes necessary to conform to this code.

E. Cleanouts on Building Sewers. Cleanouts on building sewers shall be located as set forth in §717.B of this code.

F. Minimum Size Building Sewer. No building sewer shall be less than 4 inches in size with the exception of force lines.

G. Backwater Valves. Backwater valves shall comply with the following.

1. Fixture Branches. Backwater valves shall be installed in the branch of the building drain which receives only the discharge from fixtures located below  $grade_{(G)}$ . Where fixtures are located below the level of the top of the first upstream manhole, said fixtures shall be protected by a backwater valve.

2. Material. Backwater valves shall have all bearing parts of corrosion resistant material. Backwater valves shall comply with ASME A 112.14.1 or CAN/CSA B181.1, CAN/CSA B181.2.

3. Seal. Backwater valves shall be so constructed as to insure a mechanical seal against backflow.

4. Diameter. Backwater valves, when fully opened, shall have a capacity not less than that of the pipes in which they are installed.

5. Location. Backwater valves shall be so installed to be accessible for service and repair.

H. Installation of Building Sewers. The installation of building sewers shall comply with the following. [formerly Appendix I - Installation of Building Sewers]

1. Cast Iron Soil Pipe. Cast iron soil pipe shall be installed in accord with the following requirements.

a. Trench Construction. Pipe shall be installed in as narrow a trench as possible while providing sufficient width for joint assembly.

b. Bedding. Pipe shall be installed so that the trench bottom provides support of the pipe barrel. Hub holes and coupling holes shall be provided.

c. Rock. When rock larger than 1 1/2 inches (38.1 mm) in diameter is encountered during installation, it shall be removed from the trench bottom and a 6-inch (152.4 mm) layer of selected fill shall be added to provide uniform support.

d. Backfilling. Backfill trench following test. When backfilling, care shall be taken to protect the pipe from large rocks, stone, or frozen fill material which could damage the pipe.

2. Clay Pipe. Clay pipe shall be installed in accord with the following requirements.

a. Trench and Material Preparation. The trench and material preparation for clay pipe shall be as follows:

i. Width of trenches in which clay pipe is to be installed shall be such as to provide adequate space for workmen to place and joint the pipe properly.

ii. Bell holes shall be excavated so that, after placement, only the barrel of the pipe receives bearing pressure from the trench bottom.

iii. Preparation of the trench bottom and placement of the pipe shall be carefully done so that, when in final position, the pipe is true to line and  $grade_{(S)}$ .

iv. Pipe shall be protected during handling against impact shock and free fall. No pipe shall be used in the work which does not conform to the appropriate ASTM standard.

b. Pipe Laying and Joining. The pipe laying and joining of clay pipe shall be as follows:

i. The laying of pipe in finished trenches shall be commenced at the lowest point, with the spigot ends pointing in the direction of flow.

ii. All pipe shall be laid with ends abutting and true to line and  $grade_{(S)}$ . They shall be carefully centered, so that when laid they will form a sewer with a uniform invert.

iii. Pipe shall be set firmly according to line and  $grade_{(S)}$ , and, preparatory to making pipe joints, all surfaces of the portion of the pipe to be joined shall be cleaned and dried. The joints shall then be carefully adjusted and filled with the jointing material.

iv. Trenches shall be kept water-free during joining and for a sufficient period thereafter to allow the jointing material to become fully set and completely resistant to water penetration. Trenches shall be backfilled immediately after pipe is laid therein to prevent dislocation of the sewer line or jointing material, except when factory applied flexible compression joints are used.

c. Testing. The clay pipe sewer line shall be tested as required in §319 of this code, or as prescribed by the local plumbing official.

3. Plastic Pipe. Plastic pipe shall be installed in accord with the following requirements.

a. Trenching and Supporting. The trenching and supporting of plastic pipe shall be as follows:

i. Trenching. Excavate to desired *grade*<sub>(S)</sub>. Use template to detect high spots and holes. Fill holes and depressions, tamping thoroughly.

ii. Where trenching conditions are difficult, pipe shall be uniformly supported throughout using treated timber, concrete pad, sand, or select backfill properly tamped.

b. Laying, Bedding and Backfilling. The laying, bedding and backfilling of plastic pipe shall be as follows.

i. Lay the pipe line as described. Be sure the pipe is bedded in the selected backfill one-fourth to one-third of the pipe diameter. Under no circumstances should bricks or other supports be used to bring pipe to *grade*<sub>(S)</sub>.

ii. After pipe is bedded and checked for *grade*<sub>(S)</sub>, additional selected backfill is placed by shovel at sides and over top of pipe and tamped. By careful tamping at this point, the pipe can support a much greater load and is less likely to be subsequently disturbed or shifted.

iii. Reasonably clean backfill shall be placed 12 inches (305 mm) over the pipe.

iv. The trench may now be backfilled by any conventional means, bulldozer, loader, etc., and the pipe is protected.

AUTHORITY NOTE: Promulgated in accordance with R.S. 40:4(A)(7) and R.S. 40:5(2)(3)(7)(9)(16)(17)(20).

HISTORICAL NOTE: Promulgated by the Department of Health and Hospitals, Office of Public Health, LR 38:2848 (November 2012).

### §707. Drainage Piping Installation

A. Horizontal Drainage Piping. Horizontal drainage piping shall be installed at a uniform slope but at slopes not less than permitted in §§707.B through 707.D of this code.

B. Small Piping. Horizontal building drainage piping less than 3-inch diameter shall be installed with a fall of not less than 1/4 inch per foot (21 mm per meter).

C. Large Piping. Horizontal building drains 3-inch diameter or larger shall be installed with a fall of not less than 1/8 inch per foot (10 mm per meter).

D. Minimum Velocity. Where conditions do not permit building drains and sewers to be laid with a fall as great as that specified, then a lesser slope may be permitted provided the computed velocity will be not less than 2 fps (0.61 m/s).

AUTHORITY NOTE: Promulgated in accordance with R.S. 40:4(A)(7) and R.S. 40:5(2)(3)(7)(9)(16)(17)(20).

HISTORICAL NOTE: Promulgated by the Department of Health and Hospitals, Office of Public Health, LR 38:2849 (November 2012).

### §709. Joints

A. General. This Section contains provisions applicable to joints specific to sanitary drainage piping. Provisions for those joining methods which are applicable to more than one piping system are contained in Chapter 3 of this code.

B. Caulked Joints. Caulked joints for cast-iron hub-and-spigot soil pipe shall be firmly packed with oakum or hemp and filled with molten lead not less than 1-inch (25.4 mm) deep and extending not more than 1/8 inch (3.18 mm) below rim of hub. No paint, varnish, or other coatings shall be permitted on the jointing material until after the joint has been tested and approved.

C. Joints for Plastic Pipe and Fittings. Refer to §313.H of this code for ABS and PVC joints.

D. Elastomeric Compression Gasket for Cast Iron Soil Pipe. Elastomeric compression gasketed joints for cast iron soil pipe shall comply with the following.

1. A positive-seal one piece elastomeric compression type gasket may be used for joining hub and spigot cast iron soil pipe as an alternate for lead or oakum joints. The joint is formed by inserting an approved gasket in the hub. The inside of the gasket is lubricated and the spigot end of the pipe is pushed into the gasket until seated, thus affecting a positive seal.

2. A positive-seal one piece elastomeric compression-type gasket for joining hub and spigot cast iron soil pipe may be used for drainage and waste systems above and below ground.

3. Compression gaskets for cast iron soil pipe shall be neoprene, marked as such, with ASTM C 564.

E. Hubless Cast Iron Soil Pipe System. Joints for hubless cast iron soil pipe shall comply with the following.

1. Joints for hubless cast iron soil pipe shall be made with an approved gasket and stainless steel retaining sleeve.

2. Stainless steel couplings and gaskets complying with standards listed in Table 303 of this code shall have identifying markers to indicate compliance.

3. Installation of the hubless cast iron soil pipe system shall be in accordance with CISPI 310 or the manufacturer's recommendation.

F. Borosilicate Glass Pipe. Joints for borosilicate glass pipe shall comply with the following.

1. Glass to glass connections shall be made with a bolted compression type stainless steel (300 series) coupling

with contoured acid-resistant elastomer compression ring and a fluorocarbon polymer inner seal ring.

2. Joints between glass pipe and other types of piping material shall be made with adapters having a tetrafluoroethylene (TFE) seal and according to manufacturer's recommendations.

3. Caulked joints shall conform with §709.B of this code except that acid resistant rope and acid proof cement may be used.

G. Joints for Ductile-Iron Gravity Sewer Pipe (bell and spigot). Joints in ductile-iron gravity sewer pipe shall be of the push-on joint type using a single oil resistant gasket joint. The gasket and the annular recess in the bell end of the pipe will be designed and shaped so that the gasket is locked in place against displacement. The oil resistant gaskets shall conform to AWWA C111 or ANSI A21.11 and shall comply with the performance requirements of the standard.

AUTHORITY NOTE: Promulgated in accordance with R.S. 40:4(A)(7) and R.S. 40:5(2)(3)(7)(9)(16)(17)(20).

HISTORICAL NOTE: Promulgated by the Department of Health and Hospitals, Office of Public Health, LR 38:2849 (November 2012).

#### **§711. Use of Joints**

A. Clay Sewer Pipe. Joints in vitrified clay pipe or between such pipe and other pipe shall be formed as provided in §313.D, §313.E, or §711.D of this code.

B. Concrete Sewer Pipe (for storm drains only). Joints in concrete sewer pipe or between such pipe and metal pipe shall be formed as prescribed in §313.D, §313.E, or §711.D of this code.

C. Cast Iron Soil Pipe. Joints in cast iron pipe shall be either caulked, positive-seal elastomeric compression gasket or a neoprene gasket and stainless steel retaining sleeve, as provided in §§313.B, 709.B, 709.D, and 709.E of this code.

D. PVC Transition Fittings for Dissimilar Pipe in Building Sewers. PVC transition fittings for dissimilar pipe in building sewers shall comply with the following.

1. PVC transition fittings for dissimilar pipe in building sewers shall be installed according to manufacturers' instructions.

2. Joint Sealer Adapter—to adapt cast iron, plastic, fiber, asbestos cement, clay or copper pipe to all makes of dissimilar drain pipes with PVC joint.

3. Flexible Coupling—to adapt any two of the following pipe of the same outside diameter or reducing sizes of any combination of two: clay, concrete, cast iron, steel, copper (DWV), asbestos cement, fiber drain and sewer pipe, plastic drain and sewer pipe.

4. Solvent Cemented Transition Joints Between Acrylonitrile-Butadiene-Styrene (ABS) and Poly Vinyl Chloride (PVC). Solvent cements for use in transition joints between building drains and building sewers (non-pressure applications only) shall comply with ASTM D 3138.

E. Ductile Iron Pipe without Push-On-Joints (plain end). Joints in ductile iron pipe for the building sewer without push-on-joints shall be made with a flexible coupling assembly in accordance with §313.D of this code or in accordance with the manufacturer's instructions.

AUTHORITY NOTE: Promulgated in accordance with R.S. 40:4(A)(7) and R.S. 40:5(2)(3)(7)(9)(16)(17)(20).

HISTORICAL NOTE: Promulgated by the Department of Health and Hospitals, Office of Public Health, LR 38:2850 (November 2012).

#### **§713. Connections between Drainage Piping and Fixtures**

A. Connections between drainage piping and floor outlet plumbing fixtures shall be made by means of an approved flange which is attached to the drainage piping in accordance with the provisions of this Chapter. The 4 x 3 closet flange shall be attached to the outside diameter and not to the inside diameter of the drainage piping. The floor flange shall be set on and securely anchored to the building structure.

B. Connections between drainage piping and wall hung water closets shall be made by means of an approved extension nipple or horn adapter.

C. The connection shall be bolted to the flange or carrier using corrosion resisting bolts, screws or assemblies recommended by the manufacturer.

D. An approved gasket, washer, or setting compound shall be used between the fixture and the connection. Use of commercial putty or plaster shall be prohibited as the setting compound.

AUTHORITY NOTE: Promulgated in accordance with R.S. 40:4(A)(7) and R.S. 40:5(2)(3)(7)(9)(16)(17)(20).

HISTORICAL NOTE: Promulgated by the Department of Health and Hospitals, Office of Public Health, LR 38:2850 (November 2012).

#### **§715. Prohibited Joints and Connections**

A. Drainage System. Any fitting or connection which has an enlargement, chamber, or recess with a ledge, shoulder, or reduction of pipe area, that offers an obstruction to flow through the drain, is prohibited, except as stated in §727 of this code.

B. Prohibited Fittings or Connections. Fittings or connections that offer abnormal obstruction to flow shall not be used. The enlargement of a 3-inch closet bend or stub to 4 inches shall not be considered an obstruction.

AUTHORITY NOTE: Promulgated in accordance with R.S. 40:4(A)(7) and R.S. 40:5(2)(3)(7)(9)(16)(17)(20).

HISTORICAL NOTE: Promulgated by the Department of Health and Hospitals, Office of Public Health, LR 38:2850 (November 2012).

#### **§717. Cleanouts**

A. Material and Design. The bodies of cleanout ferrules shall conform in thickness to that required for pipe and fittings of the same material, and they shall extend not less than 1/4-inch (6.35 mm) above the hub. For new work, the cleanout plug shall be of heavy brass or plastic not less than

1/8-inch (3.18 mm) thick and shall be provided with a raised nut or a recessed socket for removal. Both ferrule and plug shall have ASME standard tapered pipe threads. Heavy lead plugs may be used for repairing a cleanout where necessary. Nylon plastics may be used as an alternate material.

B. Location. The location of cleanouts shall comply with the following:

1. Each horizontal drainage pipe shall be provided with a cleanout at the upstream end of the pipe and in changes of direction over 45° (0.785 rad).

a. Exceptions. The following plumbing arrangements are acceptable in lieu of the upstream cleanout:

i. "P" traps connected to the drainage piping with slip joints or ground joint connections;

ii. "P" traps into which floor drains, shower drains or tub drains with removable strainers discharge;

iii. "P" traps into which the straight through type waste and overflow discharge with the overflow connecting to the branch of the tee;

iv. "P" traps into which residential washing machines discharge;

v. test tees or cleanouts in a vertical pipe above the flood-level rim of the fixtures that the horizontal pipe serves and not more than 4-feet (1219 mm) above the finish floor;

f. cleanout within 6-feet (1829 mm) of the junction of the building drain and the building sewer which may be rodded both ways; and,

g. water closets for the water closet fixture branch only.

2. Each building drain shall be provided with a cleanout within 6-feet (1829 mm) of the junction of the building drain and building sewer.

3. Cleanouts when installed in accordance with §717.B.2 of this code may be either outside the building or when inside the building they shall be above the flood-level rim of the fixtures that the horizontal pipe serves when installed on a soil or waste stack.

4. In addition to the upstream cleanout and the cleanout of the junction of the building drain and building sewer, cleanouts shall be located along the horizontal piping so that:

a. In pipe 3-inch nominal diameter or less, cleanouts shall be located at not more than 50 ft (15.2 m) intervals; and,

b. In pipe 4 inches nominal diameter through 6 inches nominal diameter, cleanouts shall be located at not more than 80 ft (24.4 m) intervals.

C. Concealed Piping. Cleanouts on concealed piping or piping under a floor slab or piping in a crawl space of less than 24 inches (610 mm) or a plenum of any depth shall be

extended through and terminate flush with the finished wall, floor or grade<sub>(G)</sub> or may be extended to the outside of the building. Where it is necessary to conceal a cleanout or to terminate a cleanout in an area subject to vehicular traffic, the covering plate, access door or cleanout shall be of the approved type designed and installed for this purpose.

D. Direction of Flow. Cleanouts shall be installed to permit cleaning in the direction of flow. Line cleanouts which may be rodded both ways shall be used whenever practical.

E. Use for New Fixtures Prohibited. Cleanout plugs shall not be used for the installation of new fixtures or floor drains, except where approved in writing by the plumbing official and where another cleanout of equal access and capacity is provided.

F. Trap Cleanouts. Cleanouts for traps shall comply with the following.

1. Each fixture trap, except those cast integrally or in combination with fixtures in which the trap seal is accessible, or except when a portion of the trap is readily removable for cleaning purposes, shall have an accessible brass trap screw of ample size. Cleanout plugs or caps shall be watertight and gastight. Nylon plastics may be used as an alternate material.

2. Cleanouts on the seal of a trap shall be made tight with threaded cleanout plug and approved washer. Where glass traps are required, slip joints or couplings must have a tetrafluoroethylene (TFE) seal.

G. Manholes. Sewer manholes shall be waterproofed, constructed of poured-in-place concrete or precast concrete pipe sections conforming to ASTM C 478. Bottoms shall be concrete poured on stabilized soil or aggregate subbase with inside surfaces sloped a minimum of 2 inches per foot to the pipe flow channel. All pipe connections and joints shall be sealed with approved waterstop or gasket materials and grouted. Manhole top frames and covers shall be Class 30 gray cast iron conforming to ASTM A 48/A 48M, machined for proper fit of covers in frame, coated with coal-tar pitch varnish and not less than 93 percent of the specified weight for each casting. Covers shall have the word "SEWER" cast in large letters. Similar, sealed covers with gaskets and cap screws or bolts shall be used where subject to flooding. See Figure 7 in Section 1807 of this code.

AUTHORITY NOTE: Promulgated in accordance with R.S. 40:4(A)(7) and R.S. 40:5(2)(3)(7)(9)(16)(17)(20).

HISTORICAL NOTE: Promulgated by the Department of Health and Hospitals, Office of Public Health, LR 38:2851 (November 2012).

### §719. Size of Cleanouts

A. Pipes Less Than 8-inch Nominal Size. For pipes less than 8-inch nominal size, cleanouts shall be the same nominal size as the pipe to which they are connected.

1. Exceptions

a. Pipes larger than 4-inch nominal size may be served by a 4-inch cleanout;



b. A 1 1/4-inch "P" trap connected with slip joints or ground joint connections may be used to serve 1 1/2-inch pipe; and,

c. A 1 1/2-inch "P" trap connected with slip joints or ground joint connections may be used to serve a 2-inch pipe.

B. Pipes 8 Inches and Larger Nominal Size. For pipes 8 inches and larger nominal size, cleanouts shall comply with the following.

1. Building drains may be served with a 4-inch cleanout.

2. For building sewers 8 inches and larger, manholes shall be provided and located at each change in direction and at intervals of not more than 400 ft (121.9 m). Manholes and manhole covers shall conform to §717.G of this code.

3. Building drains 8-inch nominal size and larger shall have cleanouts located at intervals of not more than 100 ft (30.5 m) and at each change of direction over 45° (0.785 rad).

AUTHORITY NOTE: Promulgated in accordance with R.S. 40:4(A)(7) and R.S. 40:5(2)(3)(7)(9)(16)(17)(20).

HISTORICAL NOTE: Promulgated by the Department of Health and Hospitals, Office of Public Health, LR 38:2851 (November 2012).

**§721. Cleanout Clearances**

A. Small Pipe. Cleanouts smaller than 3-inches shall be so installed that there is a clearance of not less than 12 inches (305 mm) for the purpose of rodding.

B. Large Pipe. Cleanouts on 3-inch or larger pipes shall be so located that there is a clearance of not less than 18 inches (457 mm) for the purpose of rodding.

AUTHORITY NOTE: Promulgated in accordance with R.S. 40:4(A)(7) and R.S. 40:5(2)(3)(7)(9)(16)(17)(20).

HISTORICAL NOTE: Promulgated by the Department of Health and Hospitals, Office of Public Health, LR 38:2852 (November 2012).

**§723. Fixture Units**

A. Values for Fixtures. Fixture unit values as given in Table 723.A of this code below designate the relative load weight of different kinds of fixtures which shall be employed in estimating the total load carried by a soil or waste pipe and shall be used in connection with the tables of sizes for soil, waste, and vent pipes for which the permissible load is given in terms of fixture units.

Fixture Type	Private	Public	Assembly	Minimum Size of Trap (in)
Bathroom group consisting of a 1.6 GPF gravity tank, flushometer tank, or flushometer valve water closet, a small P.O. 1 1/4 lavatory, and a bathtub or shower or a combination bath/shower	6.0	7.0	9.0	
Bathroom group consisting of a 1.6 GPF gravity tank, flushometer tank, or flushometer valve water closet, a large P.O. 1 1/2 lavatory, and a bathtub or shower or a combination bath/shower	7.0	8.0	10.0	
Bathroom group consisting of a greater than 1.6 GPF gravity tank or flushometer valve water closet, a small P.O. 1 1/4 lavatory, and a bathtub or shower or a combination bath/shower	7.0	9.0	11.0	
Bathroom group consisting of a greater than 1.6 GPF gravity tank or flushometer valve water closet, a large P.O. 1 1/2 lavatory, and a bathtub or shower or a combination bath/shower	8.0	10.0	12.0	
Bathtub (with or without overhead shower) or whirlpool attachments (a showerhead over a bathtub or whirlpool bathtub attachments does not increase the fixture value)	2.0	2.0		2
Bidet	1.0			1 1/4
Bidet	2.0	2.0		1 1/2
Clothes Washer, domestic, standpipe	3.0	3.0	3.0	2
Clothes Washer, commercial, pumped waste		See §§723.B and 723.C of this code for methods of computing unit value of fixtures not listed in this table or for rating of devices with intermittent flows.		
Clothes Washer, commercial, gravity waste		See §§723.B and 723.C of this code for methods of computing unit value of fixtures not listed in this table or for rating of devices with intermittent flows.		
Combination sink and tray	3.0	3.0	3.0	1 1/2
Combination sink and tray with food disposal unit	4.0	4.0	4.0	Separate traps 1 1/2
Dental unit or cuspidor		1.0	1.0	1 1/4

PUBLIC HEALTH—SANITARY CODE

Table 723.A Fixture Units Per Fixture or Group				
Fixture Type	Private	Public	Assembly	Minimum Size of Trap (in)
Dental lavatory		1.0		1 1/4
Dishwashing machine, domestic (See §§723.B and 723.C of this code for methods of computing unit value of fixtures not listed in this table or for rating of devices with intermittent flows)	2.0	2.0	2.0	1 1/2
Dishwashing machine, commercial		See §§723.B and 723.C of this code for methods of computing unit value of fixtures not listed in this table or for rating of devices with intermittent flows		
Drinking Fountain	0.5	0.5	1.0	1 1/4
Floor drains (Size of floor drain trap shall be determined by the area of the floor to be drained; therefore, for larger trap sizes, see Table 723.B of this code to determine the applicable fixture unit value. If the floor drain receives continuous or semi-continuous flows, utilize §723.C of this code to determine the fixture unit value)	1.0	2.0	2.0	2
Hub drains (When the hub drain is utilized as a direct or an indirect waste receptor for a fixture, any fixture unit value otherwise assigned to the particular fixture draining into the hub drain shall be used. If the hub drain receives continuous or semi-continuous flows, utilize §723.C of this code to determine the fixture unit value)	1.0	2.0	2.0	2
Kitchen sink, domestic	2.0	2.0		1 1/2
Kitchen sink, domestic with food waste grinder and/or dishwasher	3.0	3.0		1 1/2
Lavatory (Lavatories with 1 1/4 or 1 1/2-inch trap have the same load value; larger punch out (P.O.) plugs for the drain hole have greater flow rate)	1.0	1.0	1.0	Small P.O. 1 1/4
Lavatory (Lavatories with 1 1/4 or 1 1/2-inch trap have the same load value; larger punch out (P.O.) plugs for the drain hole have greater flow rate)	2.0	2.0	2.0	Large P.O. 1 1/2
Lavatory, barber, beauty parlor	2.0	2.0	2.0	1 1/2
Lavatory, surgeon's		2.0		1 1/2
Laundry tray (1 or 2 compartments)	2.0	2.0	2.0	1 1/2
Mobile/Manufactured Home, trailer trap	15.0			4
Shower stall, domestic	2.0	2.0	2.0	2
Showers (group) per head (See §§723.B and 723.C of this code for methods of computing unit value of fixtures not listed in this table or for rating of devices with intermittent flows)		3.0	4.0	3
<b>Sinks</b>				
Bar, private, above grade	1.0			1 1/2
Clinical, 1.6 GPF		6.0	6.0	3
Clinical, greater than 1.6 GPF		8.0	8.0	3
Curbed Cleaning Facility		3.0	3.0	3
Floor, food service		4.0	4.0	2
Floor, bar service		2.0	2.0	2
Floor, other uses (See §§723.B and 723.C of this code for methods of computing unit value of fixtures not listed in this table or for rating of devices with intermittent flows)				
Pot, scullery, etc. (See §§723.B and 723.C of this code for methods of computing unit value of fixtures not listed in this table or for rating of devices with intermittent flows)		4.0	4.0	1 1/2
Service (trap standard)		3.0	3.0	3
Service ("p" trap)		2.0	2.0	2
Surgeon's		3.0	3.0	1 1/2
Wash, (circular or multiple), normally used for hand washing, each set of faucets		2.0	3.0	Nominal 1 1/2
Wash, (circular or multiple), normally used for hand washing, no faucets (e.g., Superdome hand wash sinks in public toilet rooms)		2.0	3.0	Nominal 1 1/2
Travel Trailer, trailer trap	6.0			4
Urinals				
Exposed trap	2.0	2.0	5.0	1 1/2

Table 723.A Fixture Units Per Fixture or Group				
Fixture Type	Private	Public	Assembly	Minimum Size of Trap (in)
Pedestal, siphon jet, blowout, greater than 1.0 GPF	6.0	8.0	10.0	Trap size shall be consistent with fixture type as defined in industry standards
Wall lip, integral trap, 1.0 GPF	2.0	2.0	5.0	Trap size shall be consistent with fixture type as defined in industry standards
Wall lip, integral trap, greater than 1.0 GPF	2.0	2.0	6.0	Trap size shall be consistent with fixture type as defined in industry standards
Washout, greater than 1.0 GPF	2.0	4.0	6.0	Trap size shall be consistent with fixture type as defined in industry standards
Water Closets,				
1.6 GPF Gravity Tank	3.0	4.0	6.0	Trap size shall be consistent with fixture type as defined in industry standards
1.6 GPF Flushometer Tank	3.0	4.0	6.0	Trap size shall be consistent with fixture type as defined in industry standards
1.6 GPF Flushometer Valve	3.0	4.0	6.0	
greater than 1.6 GPF Gravity Tank	4.0	6.0	8.0	Trap size shall be consistent with fixture type as defined in industry standards
greater than 1.6 GPF Flushometer Valve	4.0	6.0	8.0	Trap size shall be consistent with fixture type as defined in industry standards

B. Fixtures Not Listed. Fixtures not listed in Table 723.A of this code above shall be estimated in accordance with Table 723.B of this code below.

Table 723.B Fixtures Not Listed	
Fixture Drain or Trap Size (in)	Fixture-Unit Value
1 1/4 and smaller	1
1 1/2	2
2	3
3	5
4	6

C. Values for Continuous Flow. For a continuous or semi continuous flow into a drainage system, such as from a pump, pump ejector, air conditioning equipment, or similar device, 2 fixture units shall be allowed for each gallon per minute (gpm) of flow (31.7 fixture units for each liter per second of flow).

D. Air Conditioning Units. The condensate or waste from an air conditioning unit shall be classified as a plumbing fixture only if connected to the plumbing system.

AUTHORITY NOTE: Promulgated in accordance with R.S. 40:4(A)(7) and R.S. 40:5(2)(3)(7)(9)(16)(17)(20).

HISTORICAL NOTE: Promulgated by the Department of Health and Hospitals, Office of Public Health, LR 38:2852 (November 2012).

### §725. Drainage System Sizing

A. Maximum Fixture Unit Load. The maximum number of fixture units that may be connected to a given size of building sewer, building drain, or horizontal branch of the building drain shall be determined using Table 725.A.1 of this code below. The maximum number of fixture units that

may be connected to a given size vertical soil or waste stack, or a horizontal branch connecting to a vertical soil or waste stack, is given in Table 725.A.2 of this code.

Table 725.A.1 Building Drains and Sewers				
Maximum Number of Fixture-Units that may be Connected to Any Portion of the Building Drain or the Building Sewer (Includes branches of the building drain. The minimum size of any building drain serving a water closet shall be 3". No building sewer shall be less than 4 inches in size)				
Diameter of Pipe (in.)	Fall in Inches Per Foot			
	1/16	1/8	1/4	1/2
2	-	-	21	26
3	-	20	27	36
		(not over two water closets)	(not over two water closets)	(not over two water closets)
4	-	180	216	250
5	-	390	480	575
6	-	700	840	1,000
8	1,400	1,600	1,920	2,300
10	2,500	2,900	3,500	4,200
12	3,900	4,600	5,600	6,700
15	7,000	8,300	10,000	2,000

Table 725.A.2 Horizontal Fixture Branches and Stacks			
Diameter of Pipe (in.)	Any Horizontal Fixture Branch	Maximum Number of Fixture Units that May be Connected to:	
		One Stack of 3 Stories	More Than 3 Stories in Height

(The minimum size of any branch or stack serving a water closet shall be 3")	(Does not include branches of the building drain. 50 percent less for battery vented fixture branches, no size reduction permitted for battery vented branches throughout the entire branch length.)	or 3 Intervals Maximum	Total for Stack	Total at One Story or Branch Interval
1 1/4	1	2	2	1
1 1/2	3	4	8	2
2	6	10	24	6
3	20 (not over two water closets)	30 (not over six water closets)	60 (not over six water closets)	16 (not over two water closets)
4	160	240	500	90
5	360	540	1100	200
6	620	960	1900	350
8	1400	2200	3600	600
10	2500	3800	5600	1000
12	3900	6000	8400	1500
15	7000	---	---	---

B. Minimum Size of Soil and Waste Stacks. No soil or waste stack shall be smaller than the largest horizontal branch connected thereto except that a 4x3 water closet connection shall not be considered as a reduction in pipe size. The soil or waste stack shall run undiminished in size from its connection to the building drain to its connection to the stack vent.

C. Future Fixtures. When provision is made for the future installation of fixtures, those provided for shall be considered in determining the required sizes of drain pipes. Construction to provide for such future installation shall be terminated with a plugged fitting or fittings at the stack so as to form no dead end.

D. Underground Drainage Piping. Any portion of the drainage system installed underground or below a basement or cellar shall not be less than 2-inch diameter. In addition, any portion of the drainage system installed underground which is located upstream from a grease trap or grease interceptor as well as the underground horizontal branch receiving the discharge there from shall not be less than 3-inch diameter.

AUTHORITY NOTE: Promulgated in accordance with R.S. 40:4(A)(7) and R.S. 40:5(2)(3)(7)(9)(16)(17)(20).

HISTORICAL NOTE: Promulgated by the Department of Health and Hospitals, Office of Public Health, LR 38:2854 (November 2012).

**§727. Offsets in Drainage Piping in Buildings of Five Stories or More**

A. Offsets of 45 Degrees or Less. An offset in a vertical stack, with a change of direction of 45° (0.785 rad) or less from the vertical, may be sized as a straight vertical stack. In case a horizontal branch connects to the stack within 2 ft (610 mm) above or below the offset, a relief vent shall be

installed in accordance with §931.C of this code, except that when the offset stack is sized for a building drain (see Column 5 in Table 725.A.1 of this code) the relief vent may be omitted.

B. Above Highest Branch. An offset above the highest horizontal branch is an offset in the stack vent and shall be considered only as it affects the developed length of the vent.

C. Below Lowest Branch. In the case of an offset in a soil or waste stack below the lowest horizontal branch, no change in diameter of the stack because of the offset shall be required if it is made at an angle of not greater than 45° (0.785 rad) from the vertical. If such an offset is made at an angle greater than 45° (0.785 rad) from the vertical, the required diameter of the offset and the stack below it shall be determined as for a building drain (See Table 725.A.1 of this code).

D. Offsets of More Than 45 Degrees. A stack with an offset of more than 45° (0.785 rad) from the vertical shall be sized as follows:

1. The portion of the stack above the offset shall be sized as for a regular stack based on the total number of fixture units above the offset;

2. The offset shall be sized as for a building drain (See Column 5 in Table 725.A.1 of this code);

3. The portion of the stack below the offset shall be sized as for the offset or based on the total number of fixture units on the entire stack, whichever is larger (See Column 4 in Table 725.A.2 of this code); and,

4. A relief vent for the offset shall be installed as provided in Chapter 9 of this code and in no case shall a horizontal branch connect within the offset or within 2 feet (610 mm) above or below the offset.

E. Omission of Offset Reliefs. Offset relief vents required by §727.D of this code may be omitted by sizing the stack and its offset one pipe size larger than required for a building drain (See Column 5 in Table 725.A.1 of this code) but in no case shall the entire stack and offset be of less cross-sectional area than that required for a straight stack plus the area of an offset relief vent as provided in §931.B of this code. Omission of relief vents in accordance with this Subsection shall not constitute approval of horizontal branch connections within the offset or within 2 feet (610 mm) above or below the offset. See §727.A of this code for offsets of 45° (0.785 rad) or less.

AUTHORITY NOTE: Promulgated in accordance with R.S. 40:4(A)(7) and R.S. 40:5(2)(3)(7)(9)(16)(17)(20).

HISTORICAL NOTE: Promulgated by the Department of Health and Hospitals, Office of Public Health, LR 38:2855 (November 2012).

**§729. Waste Stacks Serving Kitchen Sinks**

A. In a one or two family dwelling only in which the waste stack or vent receives the discharge of a kitchen sink and also serves as a vent for fixtures connected to the horizontal portion of the branch served by the waste stack,

the minimum size of the waste stack up to the highest sink branch connection shall be 2-inch diameter. Above that point the size of the stack shall be governed by the total number of fixture units vented by the stack.

1. Note: The requirement/allowance under §729.A of this code is only applicable if the requirement of §905.C.1 of this code has been satisfied elsewhere on the building drain. When the requirement of §905.C.1 of this code has not been satisfied elsewhere on the building drain, then the entire waste stack and vent mentioned in §729.A of this code shall be sized to conform to §905.C.1 of this code.

AUTHORITY NOTE: Promulgated in accordance with R.S. 40:4(A)(7) and R.S. 40:5(2)(3)(7)(9)(16)(17)(20).

HISTORICAL NOTE: Promulgated by the Department of Health and Hospitals, Office of Public Health, LR 38:2855 (November 2012).

### **§731. Sumps and Ejectors**

A. Building Drains below Sewer. Building drains which cannot be discharged to the sewer by gravity flow shall be discharged into a tightly covered and vented sump from which the liquid shall be lifted and discharged into the building gravity drainage system by automatic pumping equipment or by any equally efficient method approved by the plumbing official.

B. Check and Gate Valve Required. A check valve and a gate valve shall be installed in the pump or ejector discharge piping between the pump or ejector and the gravity drainage system. Such valve shall be accessibly located above the sump cover required by §731.A of this code, or when the discharge pipe from the ejector is below grade<sub>(G)</sub>, the valves may be accessibly located outside the sump below grade<sub>(G)</sub> in an access pit with removable access cover.

C. Sewage Ejector Sump Construction. Sumps may be constructed of cast iron or monolithically poured reinforced concrete. When concrete sumps are used, a cover attachment ring shall be embedded in the concrete in such a way as to be watertight and gastight. The attachment ring shall be designed to fit the sump cover and allow a gastight and watertight seal to be made. Other engineered sump construction and materials may be accepted by the plumbing official when designed to be watertight and gastight and otherwise meet the requirements of this Section.

D. Venting. The system of drainage piping below the sewer level shall be installed and vented in a manner similar to that of the gravity system.

E. Duplex Equipment. Sumps receiving the discharge of more than six water closets shall be provided with duplex pumping equipment.

F. Vent Sizes. Building sump vents shall be sized in accordance with Table 937.B of this code but shall in no case be sized less than 1 1/2 inches.

G. Separate Vents. Vents from pneumatic ejectors or similar equipment shall be carried separately to the open air as a vent terminal (see §927.A of this code).

H. Connections. Direct connection of a steam exhaust, blowoff, or drip pipe shall not be made with the building drainage system. Waste water when discharged into the building drainage system shall be at a temperature not higher than 140°F (60°C). When higher temperatures exist, proper cooling methods shall be provided.

I. Pumping Station. Pumping stations shall comply with the following.

1. A pumping system shall include the sump pump, sump pit and discharge piping as specified below:

a. Sump Pump. An automatic water pump for the removal of drainage from a sump, pit or low point in a residential, commercial or industrial property. Capacity and head shall be appropriate to anticipated use requirements.

b. Sump Pit. The sump pit shall be not less than 18 inches (457 mm) diameter and 24 inches (610 mm) deep, unless approved by the plumbing official. The pit shall be accessible and located such that all drainage flows into the pit due to gravity. The sump pit may be constructed of tile, concrete, steel, plastic or other approved materials. The pit bottom shall be solid and provide permanent support for the pump. The sump pit shall be fitted with a removable cover adequate to support anticipated loads in the area of use and to prevent refuse from entering the pit.

c. Discharge piping. Discharge piping shall meet the requirements of §731.B of this code.

2. Electrical service outlet when required shall meet the requirements of the NFPA 70 or local codes.

3. Sumps which receive and discharge liquid wastes or raw sewage from plumbing fixtures shall meet the applicable requirements of §731.C of this code.

J. Maximum Effluent Level. The effluent level control, etc., shall be adjusted and maintained to at all times prevent the effluent in the sump from rising to within 2 inches (51 mm) of the invert of the gravity drain inlet into the sump.

K. Ejector Connection to the Drainage System. Pumps when connected to the drainage system shall connect to the building sewer or shall connect to a wye fitting in the building drain a minimum of 10 ft (3048 mm) from the base of any soil stack, waste stack or fixture drain.

L. Macerating Systems. Macerating toilet systems shall comply with ASME A 112.3.4 and shall be installed per the manufacturer's instructions. The outlet piping from the grinder pump shall not be less than 3/4-inch and shall be fitted with a check valve and a full-flow gate or ball valve.

AUTHORITY NOTE: Promulgated in accordance with R.S. 40:4(A)(7) and R.S. 40:5(2)(3)(7)(9)(16)(17)(20).

HISTORICAL NOTE: Promulgated by the Department of Health and Hospitals, Office of Public Health, LR 38:2856 (November 2012).

### **§733. Repairs to Drainage System via Re-route**

A. In the case where it is determined that there is a broken underground drain line including, but not limited to, broken drain lines under the slab of a building, and a drain

line re-route is performed, the existing broken underground drain line shall be cut or otherwise disconnected from the entire drainage system. At the point of such cutting or disconnection, the entire circumference of the existing pipe which remains connected to the drainage system shall have a wall thickness of not less than 1/8-inch. The existing pipe which remains connected to the drainage system shall be sealed watertight and gastight using approved plumbing materials and joining/jointing methods, e.g., properly install an approved cap, plug, or cleanout on the cut or disconnected pipe.

**AUTHORITY NOTE:** Promulgated in accordance with R.S. 40:4(A)(7) and R.S. 40:5(2)(3)(7)(9)(16)(17)(20).

**HISTORICAL NOTE:** Promulgated by the Department of Health and Hospitals, Office of Public Health, LR 38:2856 (November 2012).

### **§735. Additional Provisions for Sanitary Drainage**

A. Additional provisions for sanitary drainage are found in the following:

1. LAC 51:XIV.705.H, Installation of Building Sewers;
2. LAC 51:XIV.Chapter 13, Medical Facilities Plumbing Systems;
3. LAC 51:XIV.Chapter 15, Travel Trailers and Travel Trailer Parks;
4. LAC 51:XIV.Chapter 16, Mobile/Manufactured Homes and Mobile/Manufactured Home Parks; and
5. LAC 51:XIV.Chapter 17, Sewerage System Regulations.

**AUTHORITY NOTE:** Promulgated in accordance with R.S. 40:4(A)(7) and R.S. 40:5(2)(3)(7)(9)(16)(17)(20).

**HISTORICAL NOTE:** Promulgated by the Department of Health and Hospitals, Office of Public Health, LR 38:2856 (November 2012).

## **Chapter 8. Indirect and Special Wastes**

### **§801. General**

A. Scope. The provisions of this Chapter shall govern the materials, design, construction, and installation of indirect and special wastes systems.

B. Tests. The indirect and special waste system shall be tested in accordance with §319 of this code.

**AUTHORITY NOTE:** Promulgated in accordance with R.S. 40:4(A)(7) and R.S. 40:5(2)(3)(7)(9)(16)(17)(20).

**HISTORICAL NOTE:** Promulgated by the Department of Health and Hospitals, Office of Public Health, LR 38:2857.

### **§803. Material and Size**

A. The material and size of indirect waste piping shall be in accordance with the provisions applicable to sanitary drainage piping in Chapter 7 of this code. Acid and chemical indirect waste pipes shall be of materials unaffected by the discharge of such wastes.

**AUTHORITY NOTE:** Promulgated in accordance with R.S. 40:4(A)(7) and R.S. 40:5(2)(3)(7)(9)(16)(17)(20).

**HISTORICAL NOTE:** Promulgated by the Department of Health and Hospitals, Office of Public Health, LR 38:2857 (November 2012).

### **§805. Indirect Waste Methods**

A. Air gap (drainage system). The air gap (drainage system) between the indirect waste and the building drainage system shall be at least twice the diameter of the effective opening of the indirect waste pipe, but in no case less than 2 inches (51 mm), and shall be provided by extending the indirect waste pipe to an open, accessible floor sink, service sink, floor drain, hub drain or other suitable fixture which is properly trapped and vented. The indirect waste pipe shall terminate a sufficient distance above the flood-level rim of the sink or receptor to provide the minimum required air gap and shall be installed in accordance with other applicable Sections of this code.

B. Air break (drainage system). The air break (drainage system) between the indirect waste and the building drainage system shall be installed such that the level of the lowest outlet located on the fixture, device, appliance or apparatus (to which the indirect waste pipe connects) is above the flood-level rim of the receiving sink or other receptor by a vertical distance of at least twice the diameter of the effective opening of the indirect waste pipe, but in no case less than 2 inches (51 mm). In addition, the indirect waste pipe shall terminate below the flood-level rim of the receiving sink or other receptor a distance equal to not more than one-half (1/2) the diameter of the effective opening of the indirect waste pipe.

**AUTHORITY NOTE:** Promulgated in accordance with R.S. 40:4(A)(7) and R.S. 40:5(2)(3)(7)(9)(16)(17)(20).

**HISTORICAL NOTE:** Promulgated by the Department of Health and Hospitals, Office of Public Health, LR 38:2857 (November 2012).

### **§807. Indirect Waste Connections**

A. Food Handling. Establishments engaged in the storage, preparation, selling, serving, processing or other handling of food shall have the waste piping from all food handling equipment indirectly connected to the drainage system through an air gap (drainage system) or air break (drainage system) as specified in §805 of this code. Food handling equipment includes but is not limited to the following: any sink where food is cleaned, peeled, cut up, rinsed, battered, defrosted or otherwise prepared or handled; potato peelers; ice cream dipper wells; refrigerators; freezers; walk-in coolers or freezers; ice boxes; ice making machines; fountain type drink dispensers; rinse sinks; cooling or refrigerating coils; laundry washers; extractors; steam tables; steam kettles; egg boilers; coffee urns; or similar equipment.

1. Exception. An air gap (drainage system) is the only acceptable method of indirectly connecting any food handling equipment wherein the indirect waste pipe may be under a vacuum.

B. Commercial Dishwashing Machines. Commercial dishwashing machines shall be indirectly connected.

C. Connections. The following types of connections shall be indirect waste connections in accord with the specifications stated below.

1. Water Supply Connections. Drains, overflows or relief lines from the water distribution system shall waste into an indirect waste receptor through an air gap (water distribution).

2. Air Conditioning Unit Connections. Indirect waste connections shall be provided for drains, overflows, or relief lines from air conditioning units.

D. Sterile Materials. Appliances, devices, or apparatus such as stills, sterilizers, and similar equipment, requiring water and waste connections and used for sterile material, shall be indirectly connected or provided with an air gap (drainage system) between the trap and the appliance.

E. Drips. Appliances, devices, or apparatus not regularly classed as plumbing fixtures but which have drips or drainage outlets shall be drained by indirect waste pipes discharging into an open receptacle as provided in §805 of this code.

F. Cleanliness. The sink or receptor receiving indirect wastes shall be water-supplied if the waste stream contains or is expected to contain a sufficient amount of organic matter capable of causing odors or otherwise causing a nuisance due to an insufficient dilution of the waste material discharged into the sink or receptor.

G. Receptors. Waste/plumbing receptors serving indirect waste pipe discharges shall meet the following requirements.

1. Installation. Waste receptors serving indirect waste pipes shall not be installed in any toilet room, nor in any inaccessible or unventilated space such as a closet or storeroom.

2. Strainers and Baskets. Every indirect waste receptor receiving discharge containing particles that would clog the receptor shall be equipped with a basket or other device which shall prevent passage into the drainage system of solids 1/2-inch (12.7 mm) or larger in size. The basket or device shall be removable for cleaning purposes.

3. Splashing. All plumbing receptors receiving the discharge of indirect waste pipes shall be of such shape and capacity as to prevent splashing or flooding. No plumbing fixture which is used for domestic or culinary purposes shall be used to receive the discharge of an indirect waste pipe.

H. Clear Water Wastes. Water lifts, expansion tanks, cooling jackets, sprinkler systems, drip or overflow pans or similar devices which waste clear water only, shall discharge into the building drainage system through an indirect waste.

I. Hot Water Drainage. A steam pipe shall not connect directly to any part of a drainage system, nor shall any water above 140°F (60°C) be discharged directly into any part of a drainage system.

J. Drinking Fountains. Drinking fountains may be installed with indirect wastes.

K. Swimming Pools. Piping carrying waste water from swimming or wading pools, including pool drainage, backwash from filters, water from scum gutter drains or floor drains which serve walks around pools, shall be installed as an indirect waste utilizing a circulation pump, if necessary, when indirect waste line is below the sewer *grade(s)*.

L. Residential Washing Machines (clothes washers). All residential washing machines shall connect to the building drainage system via an individual indirect waste pipe for each machine using one of the indirect waste methods specified in §805 of this code.

1. Any machines which discharge by gravity shall discharge into an adequately sized individual receptor, such as a floor sink. Such receptor/floor sink shall be properly trapped, vented, and directly connected to the drainage system.

M. Commercial Laundry Machines. All commercial laundry washing machines shall connect to the building drainage system via an individual indirect waste pipe for each machine using one of the indirect waste methods specified in §805 of this code.

1. Any machines which discharge by gravity shall individually discharge into an adequately sized receptor trough/pit or adequately sized individual receptors, such as floor sinks. Such receptor trough/pit or floor sinks shall be properly trapped, vented, and directly connected to the drainage system.

AUTHORITY NOTE: Promulgated in accordance with R.S. 40:4(A)(7) and R.S. 40:5(2)(3)(7)(9)(16)(17)(20).

HISTORICAL NOTE: Promulgated by the Department of Health and Hospitals, Office of Public Health, LR 38:2857 (November 2012).

### **§809. Limitations**

A. The following limitations/requirements shall apply to indirect waste pipes.

1. Indirect waste piping exceeding 2 ft (610 mm) long shall be trapped.

2. The maximum length of the indirect waste to indirect waste receptor shall not exceed 15-feet (4527 mm). Should an indirect waste pipe exceed 15 feet in length, a local vent shall be provided at a maximum of every 15 feet in length.

B. Cleaning. Indirect waste piping shall be so installed as to permit ready access for flushing and cleansing.

AUTHORITY NOTE: Promulgated in accordance with R.S. 40:4(A)(7) and R.S. 40:5(2)(3)(7)(9)(16)(17)(20).

HISTORICAL NOTE: Promulgated by the Department of Health and Hospitals, Office of Public Health, LR 38:2858 (November 2012).

### **§811. Additional Provisions for Indirect and Special Wastes**

A. Additional provisions for indirect and special wastes are found in the following:

1. LAC 51:XIV.Chapter 13, Medical Facilities Plumbing Systems;

2. LAC 51:XIV.Chapter 15, Travel Trailers and Travel Trailer Parks;

3. LAC 51:XIV.Chapter 16, Mobile/Manufactured Homes and Mobile/Manufactured Home Parks; and,

4. LAC 51:XIV.Chapter 17, Sewerage System Regulations;

AUTHORITY NOTE: Promulgated in accordance with R.S. 40:4(A)(7) and R.S. 40:5(2)(3)(7)(9)(16)(17)(20).

HISTORICAL NOTE: Promulgated by the Department of Health and Hospitals, Office of Public Health, LR 38:2858 (November 2012).

## Chapter 9. Vents

### §901. General

A. Scope. The provisions of this Chapter shall govern the materials, design, construction, and installation of vents.

B. Protection of Trap Seals. The protection of trap seals from siphonage or back pressure shall be accomplished by the appropriate use of soil or waste stacks, vents, revents, back vents, loop vents, circuit or continuous vents or combination thereof, installed in accordance with the requirements of this Chapter and the limitations set forth in §303.H.2 of this code.

C. Tests. The venting system shall be tested in accordance with §319.B of this code.

D. Engineered Systems. Engineered sanitary drainage and venting systems shall conform to the provisions of Chapter 12, Alternate Designed Plumbing Systems, of this code.

AUTHORITY NOTE: Promulgated in accordance with R.S. 40:4(A)(7) and R.S. 40:5(2)(3)(7)(9)(16)(17)(20).

HISTORICAL NOTE: Promulgated by the Department of Health and Hospitals, Office of Public Health, LR 38:2858 (November 2012).

### §903. Materials

A. Vents. Pipe, tubing, and fittings for the vent piping system shall comply with the provisions of Chapter 7 of this code.

B. Specific Type. Standards given in Table 703 of this code apply to the specific materials approved for use and as indicated in the various Sections in this Chapter.

C. Piping above Ground. Vent piping shall be of cast iron, galvanized steel, brass or copper pipe, copper tube of a weight not less than that of copper drainage tube Type DWV, and Schedule 40 plastic piping. Vent piping used in acid waste systems shall be of the same material used in the acid soil and waste piping (see §703.F of this code).

D. Piping Underground. Vent piping placed underground shall be of cast iron, copper tube of a weight not less than that of Type DWV, Schedule 40 plastic piping or heavy schedule borosilicate glass, provided that other materials may be used for underground vents when found adequate

and installed as directed by the plumbing official. Vent piping used in acid waste systems shall be of the same material used in the acid soil and waste piping (see §703.F of this code). Materials subject to corrosion shall be protected when installed in corrosive soil.

E. Fittings. Fittings shall be compatible to the type of pipe used in the vent system as required by §§903.B, 903.C and 903.D of this code.

1. Vent pipes installed less than 6 inches above the flood-level rim of fixture(s) served shall be installed with approved drainage fittings (i.e., short turn quarter bends shall be prohibited).

AUTHORITY NOTE: Promulgated in accordance with R.S. 40:4(A)(7) and R.S. 40:5(2)(3)(7)(9)(16)(17)(20).

HISTORICAL NOTE: Promulgated by the Department of Health and Hospitals, Office of Public Health, LR 38:2858 (November 2012).

### §905. Vent Stacks

A. Installation. A vent stack or main vent shall be installed with a soil or waste stack whenever back vents, relief vents or other branch vents are required in two or more branch intervals. No fixture shall be permitted to drain into any stack above any vent connection.

B. Terminal. The vent stack shall terminate independently above the roof of the building or shall be connected with the extension of the soil or waste stack (stack-vent) at least 6 inches (152 mm) above the flood-level rim of the highest fixture.

C. Main Stack. The main vent stack or stack vent shall comply with the following.

1. Every building in which plumbing is installed shall have at least one main vent stack or stack vent, of not less than 3-inch (76 mm) diameter, for each building drain, when connected separately to a building sewer, septic tank, or other sewage collection and/or disposal system approved by the state health officer. Such vent shall run undiminished in size and as directly as possible from the building drain through to the open air above the roof.

2. The main vent stack in a detached garage or other accessory building where only a washing machine or laundry tray is installed may be 1 1/2 inches (38 mm).

AUTHORITY NOTE: Promulgated in accordance with R.S. 40:4(A)(7) and R.S. 40:5(2)(3)(7)(9)(16)(17)(20).

HISTORICAL NOTE: Promulgated by the Department of Health and Hospitals, Office of Public Health, LR 38:2859 (November 2012).

### §907. Vent Terminals

A. Roof Extension. Extensions of vent pipes through a roof shall be terminated at least 6 inches (152 mm) above the roof, except that where a roof is to be used for any purpose other than weather protection, the vent extension shall be run at least 9 feet (2743 mm) above the roof or any structure where people may congregate.

B. Frost Closure. Where there is possibility of frost closure, the vent extension through a roof shall be at least 3-



inch diameter. When it is found necessary to increase the size of the vent terminal, the change in diameter shall be made at least 1 foot (305 mm) inside the building.

C. Flashings. The juncture of each vent pipe with the roof line shall be made watertight by proper flashing (see §§303.G.1.b and 303.G.2.b of this code).

D. Flag Poling. Vent terminals shall not be used to support flag poles, TV aerials, or similar items, except when the piping has been anchored to the construction and approved as safe by the plumbing official.

E. Location of Vent Terminal. A vent terminal from a drainage system shall not be located directly beneath any door, window or other fresh air intake opening of the building or of an adjacent building, nor shall any such vent terminal be within 10 feet (3048 mm) horizontally of such an opening unless it is at least 2 feet (610 mm) above the top of such opening.

F. Extensions through Wall. Vent terminals extending through a wall shall terminate at least 6 inches (152 mm) above the roof and the opening shall face upward. Vent terminals shall not terminate under the overhang of the building.

G. Air Admittance Valves for Venting Plumbing Fixtures and Fixture Branches. Air admittance valves are not approved for venting of plumbing fixture traps.

AUTHORITY NOTE: Promulgated in accordance with R.S. 40:4(A)(7) and R.S. 40:5(2)(3)(7)(9)(16)(17)(20).

HISTORICAL NOTE: Promulgated by the Department of Health and Hospitals, Office of Public Health, LR 38:2859 (November 2012).

### §909. Vent Grades<sub>(s)</sub> and Connections

A. *Grade<sub>(s)</sub>*. All vent and branch vent pipes shall be so graded and connected as to drip back to the soil or waste pipe by gravity.

B. Vertical Rise. The vertical rise of vent pipes shall conform with the following.

1. Vertical Rise of Vent for a Horizontal Soil or Waste Pipe. Where vent pipes (including wet vent pipes) connect to a horizontal soil or waste pipe, the vent shall be taken off above the center line of the soil pipe, and the vent pipe shall rise vertically, or at an angle not exceeding 45° (0.785 rad) from the vertical, before offsetting horizontally.

2. Vertical Rise of Vent for a Vertical Soil or Waste Pipe. Where vent pipes connect at or below the lowest fixture connection, to a vertical soil or waste pipe, such vent shall be taken off at an angle not exceeding 45° (0.785 rad) to the vertical to a point at least 6 inches (152 mm) above the flood-level rim of the lowest fixture it is venting before offsetting horizontally.

C. Height Above Fixtures. A connection between a vent pipe and a vent stack or stack vent shall be made at least 6 inches (152 mm) above the flood-level rim of the highest fixture served by the vent. Horizontal vent pipes forming branch vents, relief vents, or loop vents shall be at least 6

inches (152 mm) above the flood-level rim of the highest fixture served.

AUTHORITY NOTE: Promulgated in accordance with R.S. 40:4(A)(7) and R.S. 40:5(2)(3)(7)(9)(16)(17)(20).

HISTORICAL NOTE: Promulgated by the Department of Health and Hospitals, Office of Public Health, LR 38:2859 (November 2012).

### §911. Bar and Fountain Sink Traps

A. Traps serving sinks which are part of the equipment of island bars, island soda fountains, island counters and similar equipment need not be conventionally vented when the location and construction of such bars, soda fountains and counters make it impossible to do so. When these conditions exist, traps which are roughed in above the floor shall be vented by extending the vent as high as possible, but not less than the drainboard height and then returning it downward and connecting it to the horizontal sink drain immediately downstream from the vertical fixture drain. The return vent shall be connected to the horizontal branch through a wye-branch fitting and shall, in addition, be provided with a foot vent taken off the vertical fixture vent by means of a wye-branch immediately below the floor and extending to the nearest partition and then through the roof to the open air or may be connected to other vents at a point not less than 6 inches (152 mm) above the flood-level rim of the fixtures served. Vent pipes installed less than 6 inches above the flood-level rim of the sink shall be installed with approved drainage fittings in accordance with §903.E.1 of this code and a minimum slope of 1/4 inch per foot back to the drain shall be maintained. The return bend used under the drainboard shall be a 45-degree, a 90-degree and a 45-degree elbow in the order named. Pipe sizing shall be as elsewhere in this code. The island sink drain, upstream of the returned vent, shall serve no other fixtures. An accessible cleanout shall be installed on the vertical vent pipe under the drainboard and another cleanout should be installed in the vertical portion of the foot vent. (The cleanout recommended on the vertical portion of the foot vent shall be located at least 6 inches above the flood level rim of the sink but not more than 4 feet above the finish floor. Preferably, the vertical portion of the foot vent and its recommended cleanout shall be located on an outside wall with the cleanout accessible outside or, if this is not possible, behind a refrigerator, for example, such that the cleanout access is not aesthetically objectionable to the occupants.) For food service establishments, drainage shall be in accordance with §807.A of this code (see Figure 911.A of this code below).

SPECIAL VENTING FOR ISLAND SINK

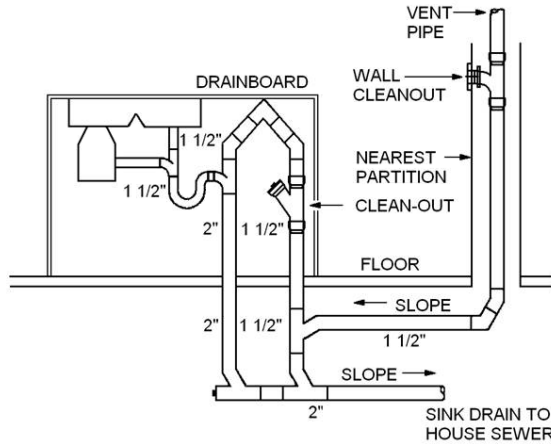


Figure 911.A—Special Venting for Island Sink

AUTHORITY NOTE: Promulgated in accordance with R.S. 40:4(A)(7) and R.S. 40:5(2)(3)(7)(9)(16)(17)(20).

HISTORICAL NOTE: Promulgated by the Department of Health and Hospitals, Office of Public Health, LR 38:2859 (November 2012).

§913. Fixture Vents

A. Distance of Trap from Vent. Each fixture trap shall have a protecting vent so located that the slope and the developed length (see Figures 913.A and 913.C of this code) in the fixture drain from the trap weir to the vent fitting are within the requirements set forth in Table 913.A of this code, except as permitted by §923.A of this code. For water closets or other floor or wall mounted fixtures having an integral trap, the developed length shall be the distance from the internal vent opening to the face of the flange to which the fixture is bolted or otherwise fastened.

Size of Fixture Drain (in)	Size of Trap (in)	Fall (in/ft)	Max. Distance From Trap
1 1/4	1 1/4	1/4	3 ft 6 in
1 1/2	1 1/4	1/4	5ft
1 1/2	1 1/2	1/4	5ft
2	1 1/2	1/4	6ft
2	2	1/4	6ft
3	3	1/8	10ft
4	4	1/8	12ft

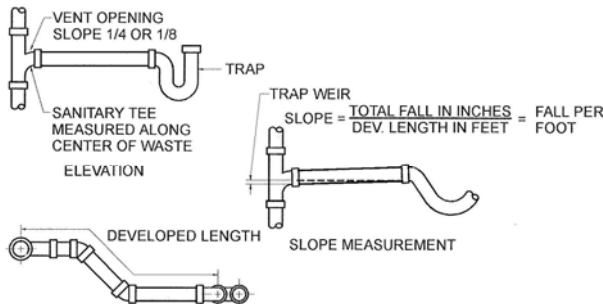
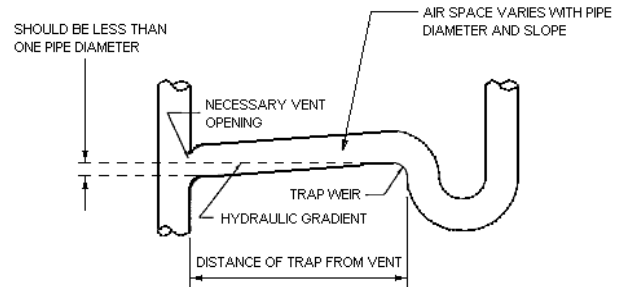


Figure 913.A—Distance of Fixture Trap from Vent

B. Trap Seal Protection. The plumbing system shall be provided with a system of vent piping which will permit the admission or emission of air so that under normal and intended use the seal of any fixture trap shall not be subjected to a pressure differential of more than 1-inch of water (249 Pa).

C. Location of Vent Opening. The internal vent pipe opening from a soil or waste pipe, except for water closets and similar fixtures, shall not be below the top weir of the trap's outlet.



(NOTE: If the distance of the vent from the trap is excessive, the necessary vent opening will be below the trap weir and the trap will have a greater tendency to self-siphon)

Figure 913.C—Location of Vent Opening

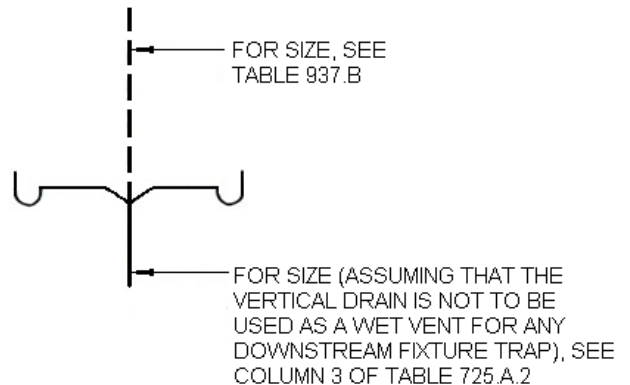
D. Crown Vent. A vent shall not be installed within 2 pipe diameters of the trap weir (see §1001.E.4 of this code).

AUTHORITY NOTE: Promulgated in accordance with R.S. 40:4(A)(7) and R.S. 40:5(2)(3)(7)(9)(16)(17)(20).

HISTORICAL NOTE: Promulgated by the Department of Health and Hospitals, Office of Public Health, LR 38:2860 (November 2012).

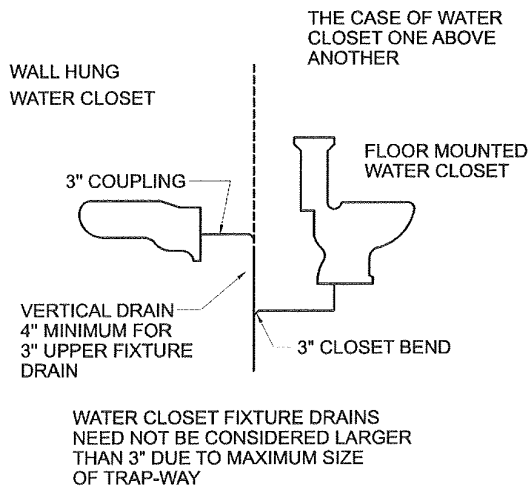
§915. Common Vent

A. Individual Vent. An individual vent, installed vertically, may be used as a common vent for two fixture traps when both fixture drains connect with a vertical drain at the same level. Also, see §311.C of this code in regards to double sanitary tee pattern limitations on fixtures or appliances with a pumping action discharge.

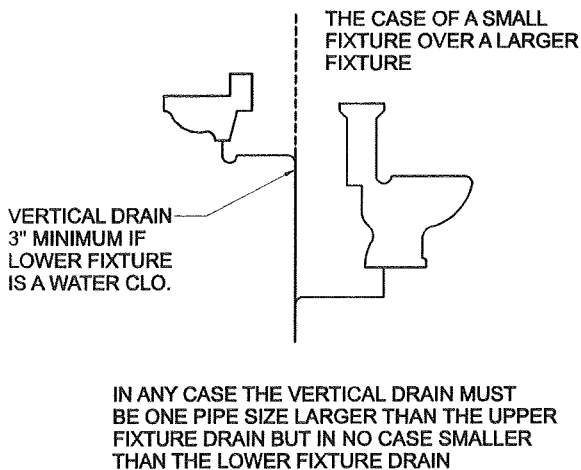


**Figure 915.A—Common Vent**  
**(Fixtures Connecting at Same Level)**

B. Fixtures on Same Floor Connecting at Different Levels in the Stack. A common vent may be used for two fixtures set on the same floor level but connecting at different levels in the stack, provided the vertical drain is one pipe size larger than the upper fixture drain but in no case smaller than the lower fixture drain, whichever is the larger, and that both drains conform to Table 913.A of this code. A minor fixture, such as a lavatory, shall enter the common vent above a major fixture, such as a water closet [i.e., a minor (having less fixture units) over/upstream of a major (having more fixture units) rule]. See Figure 915.A, Figure 915.B, and Section 915.D of this code.



**Figure 915.B (1 of 2)—Common Vent**  
**(Fixtures Connecting at Different Levels)**



**Figure 915.B (2 of 2)—Common Vent**  
**(Fixtures Connecting at Different Levels)**

C. Distance. The maximum distance allowed between back-to-back or side-by-side fixture traps and their vent, when vented by a "common vent", shall be in accord with the requirements of §913.A of this code. In addition, the following shall apply.

1. Two fixtures set back-to-back, or side-by-side connected to a common horizontal branch within the distance allowed between a trap and its vent may be served with one continuous soil or waste vent-pipe, provided that each fixture wastes separately into an approved double fitting having inlet openings at the same level. The vent shall be installed in a vertical position at the interconnection of the fixture drains or downstream of the interconnection in accordance with the distance of trap from vent requirements in Table 913.A of this code. See left-hand depiction of Figure 915.C in this code.

2. When not more than two fixtures are set back-to-back or side-by-side, within the distance allowed between a trap and its vent, they may be connected to a common horizontal branch served by a common vertical vent located between the two fixtures, provided the branch is one pipe size larger than either of the fixture drains, except as permitted by §923.A of this code. This vent shall not serve as a waste for any other fixture. A minor fixture, such as a floor drain, shall enter the common horizontal branch served by a common vertical vent upstream of a major fixture, such as a water closet [i.e., a minor (having less fixture units) over/upstream of a major (having more fixture units) rule]. See right-hand depiction of Figure 915.C in this code.

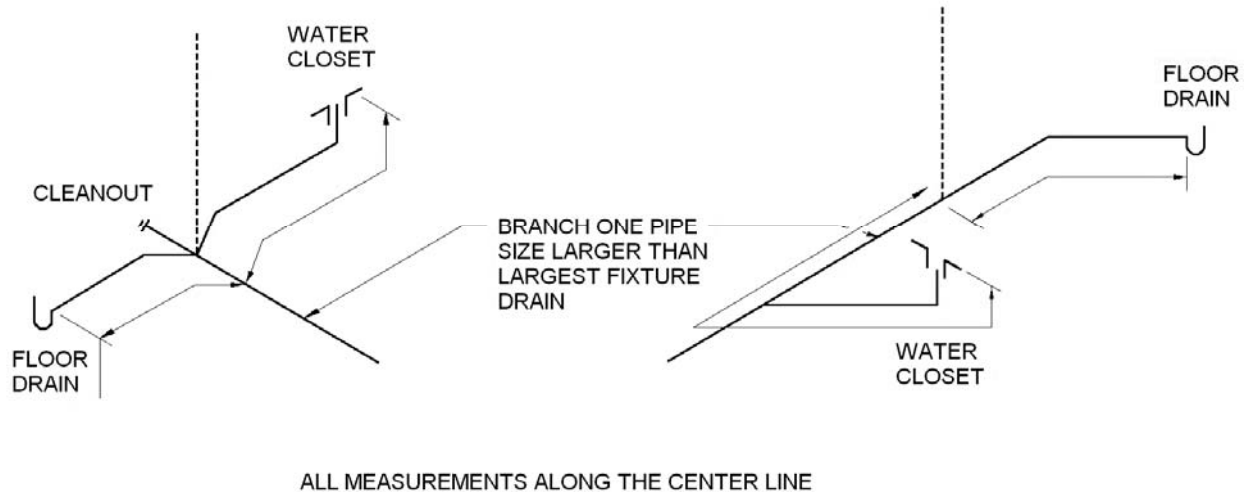


Figure 915.C—Common Vent  
(Distance between Trap and Vent)

D. For the purpose of this Section, 3-inch (76 mm) or 4-inch (102 mm) floor or shower drains, up to and including 4-discharge fixture unit (dfu) water closets or pedestal urinals shall be considered as having 3-inch (76 mm) drains. For more than two fixtures on a common horizontal branch, see §925.A (Battery Venting) of this code.

1. Certain water closets and other plumbing fixtures (such as clinical sinks, flushing rim service sinks, etc.), in either public use or assembly use, have ratings exceeding 4 dfu. In such case, the horizontal branch serving such water closets or other plumbing fixtures shall be a minimum of 5-inch (127 mm) in diameter when a common vertical vent is used, as provided in §915.C.2 of this code.

AUTHORITY NOTE: Promulgated in accordance with R.S. 40:4(A)(7) and R.S. 40:5(2)(3)(7)(9)(16)(17)(20).

HISTORICAL NOTE: Promulgated by the Department of Health and Hospitals, Office of Public Health, LR 38:2861 (November 2012).

#### §917. Vents for Fixture Trap below Trap Weir/Fixtures Entering at Different Levels

A. Hydraulic Gradient. Fixture drains shall be vented within the hydraulic gradient between the top weir of the trap's outlet and the internal opening of the vent connection, but in no case shall the unvented drain exceed the distance provided for in Table 913.A of this code. See §913.C of this code.

B. Different Levels. If any single branch interval has fixtures entering the stack at different vertical levels, the fixtures other than the fixture entering at the highest level shall be individually vented, except as may be otherwise permitted in other Sections of this Chapter. See §§915.B, 921.A, 923.C, and 925.C of this code.

AUTHORITY NOTE: Promulgated in accordance with R.S. 40:4(A)(7) and R.S. 40:5(2)(3)(7)(9)(16)(17)(20).

HISTORICAL NOTE: Promulgated by the Department of Health and Hospitals, Office of Public Health, LR 38:2862 (November 2012).

#### §919. Wet Venting

A. Single Bathroom Groups. A single bathroom group of fixtures may be installed with the drain from a back vented lavatory serving as a wet vent for a bathtub or shower stall and for the water closet, provided that the wet vent is one pipe size larger than the upper fixture drain but in no case smaller than the lower fixture drain, whichever is the larger, and that both fixture drains conform to Table 913.A of this code. No urinal exceeding 2.0 dfu or washing machine drain shall discharge into any wet vent. A minor fixture, such as a bathtub or shower, shall enter the wet vent/drain pipe upstream of a major fixture, such as a water closet [i.e., a minor (having less fixture units) over/upstream of a major (having more fixture units) rule]. The dry vent servicing the wet vent shall be sized based upon the developed length and the total fixture units connected thereto in accord with §937.B and Table 937.B of this code. (Note: Per the definition of "wet vent", the wet vent terminates at the connection with the water closet's fixture drain. If the water closet is being vented by a method other than the wet vent, the wet vent terminates where it connects to the stack, the lowest or most downstream fixture drain, or where it connects to a separate horizontal branch line or the building drain, as appropriate.)

B. Double Bath. Bathroom groups back-to-back on the top floor consisting of two bathtubs or shower stalls may be installed on the same horizontal branch with a common vent for the lavatories with no back vent for the water closets, bathtubs or shower stalls, provided that the wet vent is one pipe size larger than the upper fixture drain but in no case smaller than the lower fixture drain, whichever is the larger, and that both fixture drains conform to Table 913.A of this code. No urinal exceeding 2.0 dfu or washing machine drain shall discharge into any wet vent. A minor fixture, such as a bathtub or shower, shall enter the wet vent/drain pipe upstream of a major fixture, such as a water closet [i.e., a minor (having less fixture units) over/upstream of a major (having more fixture units) rule]. The dry vent servicing the

wet vent shall be sized based upon the developed length and the total fixture units connected thereto in accord with §937.B and Table 937.B of this code.

NOTE: Per the definition of *wet vent*, the wet vent terminates at the connection with the water closet's fixture drain. If the water closet is being vented by a method other than the wet vent, the wet vent terminates where it connects to the stack, the lowest or most downstream fixture drain, or where it connects to a separate horizontal branch line or the building drain, as appropriate.

C. Multistory Bathroom Groups. On the lower floors of a multistory building, the waste pipe from one or two lavatories may be used as a wet vent for one or two bathtubs or showers provided that:

1. the wet vent and its extension to the vent stack is not less than 2-inch (51 mm) diameter;
2. each water closet below the top floor is individually back vented;
3. the vent stack is sized in accordance with Table 919.C of this code; and,
4. the lowest wet vent shall be sized for the total bathtubs or showers connected to the stack but in no case shall the wet or dry portion of the lowest vent be less than required for the vent stack itself.

Number of Wet Vented Fixtures	Diameter of Vent Stacks (In.)
1 or 2 bathtubs or showers	2
3 to 5 bathtubs or showers	2 1/2
6 to 9 bathtubs or showers	3
10 to 16 bathtubs or showers	4

AUTHORITY NOTE: Promulgated in accordance with R.S. 40:4(A)(7) and R.S. 40:5(2)(3)(7)(9)(16)(17)(20).

HISTORICAL NOTE: Promulgated by the Department of Health and Hospitals, Office of Public Health, LR 38:2862 (November 2012).

**§921. Stack Venting**

A. Fixture Groups. A single bathroom group of fixtures, consisting of a water closet, lavatory, shower or tub, and a kitchen sink (with disposal and dishwasher) located back-to-back to the bathroom, or two bathrooms back-to-back each consisting of one toilet, lavatory, shower or tub may be installed without individual fixture vents in a one story building or on the top floor of a building provided each fixture drain connects independently to the stack and that the tub and/or shower and water closet enter the stack at the same level and in accordance with the requirements in Table 913.A of this code. The wet vent portion of the stack vent shall be one pipe size larger than the upper fixture drain but in no case smaller than the lower fixture drain, whichever is the larger.

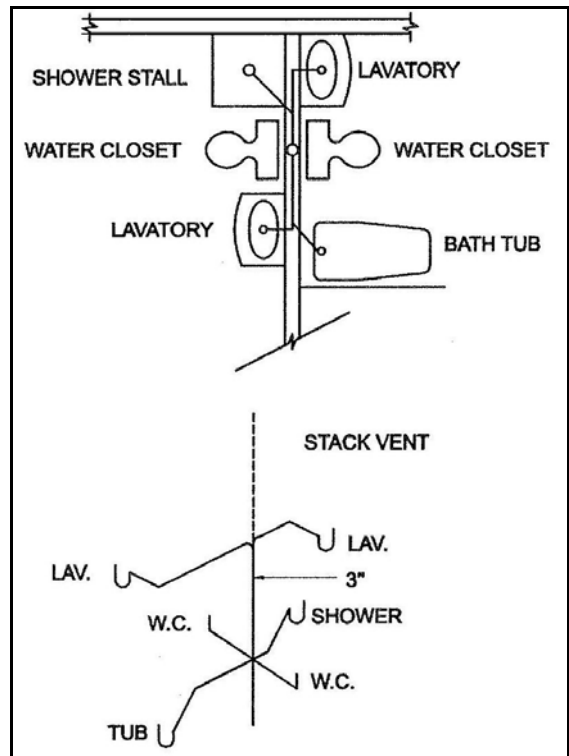
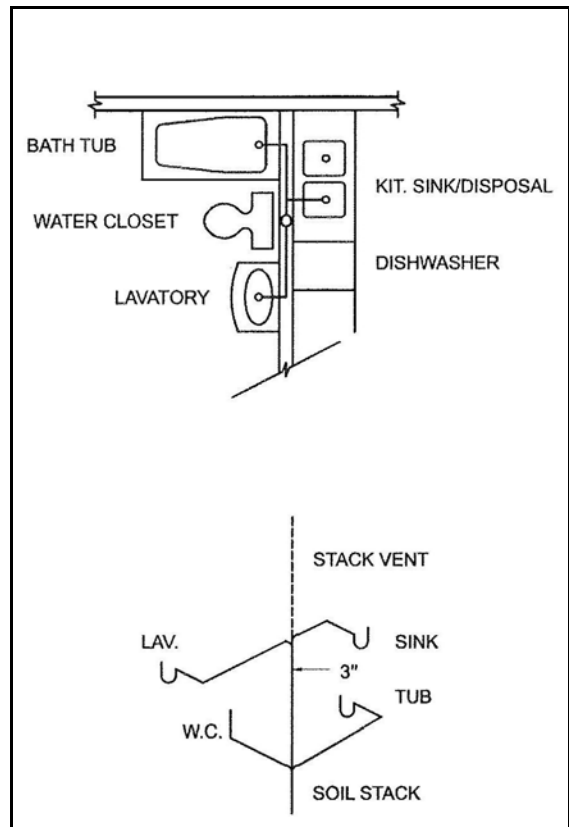


Figure 921.A—Stack Venting

B. Lower Floors. The lower floors of multistoried buildings may also be vented as in §921.A of this code provided that a separate wye and upright one-eighth bend is installed in the stack and that the stack group is installed above the one-eighth bend and that at least a 2-inch (51 mm) diameter vent is installed 6 inches (152 mm) above the flood

level of the highest fixture in the stack group. See Figure 921.B of this code below.

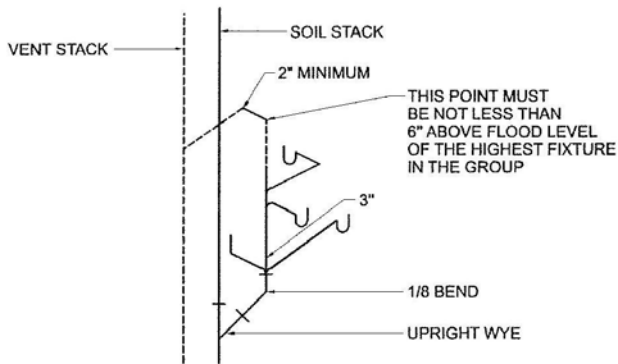


Figure 921.B—Stack Venting Lower Floors

AUTHORITY NOTE: Promulgated in accordance with R.S. 40:4(A)(7) and R.S. 40:5(2)(3)(7)(9)(16)(17)(20).

HISTORICAL NOTE: Promulgated by the Department of Health and Hospitals, Office of Public Health, LR 38:2863 (November 2012).

**§923. Individual Fixture Reventing**

A. Horizontal Branches. A horizontal waste branch meeting the following criteria shall effectively provide an exception to the need for a revent pipe(s).

1. Provided:
  - a. the horizontal branch is full size throughout its length;
  - b. each fixture drain enters the horizontal branch via a wye and 1/8th bend or a combination wye and 1/8th bend;
  - c. the wastes are connected with a pitch of not more than 1/4 inch per foot (21 mm per meter);
  - d. that a 2-inch "P" trap shall be the minimum for tubs and showers;
  - e. the waste openings in the horizontal branch shall not be less than 1 1/4 inches for lavatories and 1 1/2 inches for a sink; and,
  - f. that one drinking fountain shall be considered as one lavatory; then, without the use of reventing:
    - i. one sink and one lavatory, or one tub, or one shower, or three lavatories within 8 feet (2438 mm) developed length of a main vented line may be installed on a 2-inch horizontal waste branch; or,
    - ii. two lavatories within 5 feet (1524 mm) developed length of a main vented line may be installed on a 1 1/2-inch horizontal waste branch.

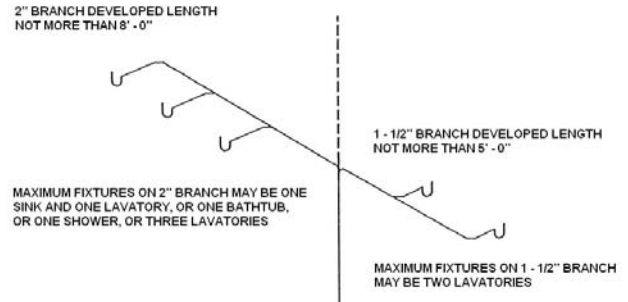


Figure 923.A

B. Where Required. All fixtures discharging downstream from a water closet shall be individually vented.

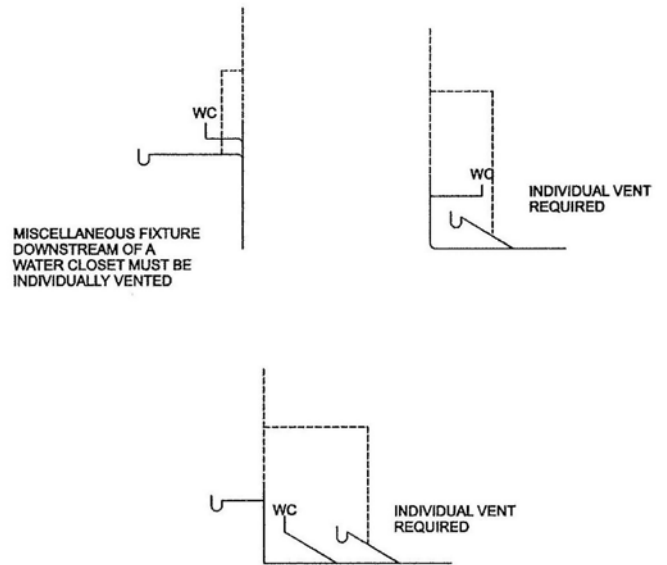


Figure 923.B—Required Individual Vents

C. Limits of Fixture Units Above Bathtubs and Water Closets. Up to a total of three fixture units may be placed on a soil or waste stack on floors above the highest water closet or bathtub connection without the use of a revent pipe(s) provided:

1. the soil or waste stack is not less than 3-inch diameter;
2. the total fixture unit load on the stack does not exceed the limitations of Table 725.A.2 of this code;
3. the largest fixture drain opening into the stack does not exceed the nominal diameter of the trap of the fixture to be connected except as permitted in §923.A of this code. Such opening for multiple fixture connections shall be limited to use on one floor only;
4. each fixture above the highest tub or water closet is no farther from the stack than permitted in Table 913.A of this code; and,

5. all fixtures on lower floors are vented as otherwise required by this Chapter.

AUTHORITY NOTE: Promulgated in accordance with R.S. 40:4(A)(7) and R.S. 40:5(2)(3)(7)(9)(16)(17)(20).

HISTORICAL NOTE: Promulgated by the Department of Health and Hospitals, Office of Public Health, LR 38:2864 (November 2012).

### §925. Battery Venting

A. A branch soil or waste pipe of uniform diameter throughout its length, to which are connected in battery a maximum of eight floor-level fixtures [floor outlet water closets, back outlet water closets (provided they connect horizontally into the battery vented section), floor drains, bathtubs, and showers] and which do not exceed 50 percent of the fixture units allowed by column two of Table 725.A.2 of this code, may be vented by a circuit or loop vent system connected downstream of the most upstream fixture drain (between the two uppermost fixture drains). In addition, battery vented branches on the top floor of a building and serving three or more fixtures shall be provided with a relief vent connected immediately downstream of the first downstream fixture connection of the battery vented section. When a battery vented branch is installed below the uppermost floor of the building, regardless of the number of fixtures served, it shall be provided with a relief vent connected immediately downstream of the first downstream fixture connection of the battery vented section. When lavatories or similar fixtures having a fixture unit rating of four or less and a maximum 2-inch fixture drain discharge from above such branches, each vertical branch shall be provided with a continuous vent. Such fixtures shall be located on the same floor as the battery vented group and the waste from such fixtures is required to enter the battery vented section from the horizontal. Fixtures having fixture unit ratings greater than four shall not discharge into such branch from above unless all fixtures in the battery group are individually vented. Fixtures from an upper floor or from an adjoining or other room(s) or space(s) (other than back-to-back installations, for example, back-to-back to bathrooms) shall not discharge into a battery vented branch. Floor level fixtures, including but not limited to floor drains, discharging downstream from a water closet shall be individually vented (see §925.C.5 of this code). Each fixture drain/trap which is connected to a battery vented soil or waste pipe branch shall conform with the distance of trap from vent requirements in Table 913.A of this code. The developed length distance from the weir of the trap or the flange of the water closet to the battery vented soil or waste pipe branch shall be used to determine compliance with Table 913.A of this code.

1. Exception. The relief vent, connected immediately downstream of the first downstream fixture connection of the battery vented section, may be omitted on a top floor installation of a battery vented section provided a stack vent or vent stack is located downstream of the first downstream horizontal fixture connection.

B. Vent Connections. Any vent or vents on the battery vented section shall be taken off from the vertical or at an

angle not exceeding 45 degrees from the vertical in conformity with §909.B.1 of this code.

1. In addition, if a fixture having a fixture unit rating of four or less and a maximum 2-inch fixture drain discharge wastes into either the upper vent or the downstream relief vent of a battery vented section, the wet portion of such vent shall not be smaller than the horizontal battery branch.

a. Exception. The vent branch connection may be taken off horizontally provided it is washed by not more than four fixture units, other than water closets, and the wet portion of the vent is not smaller than the horizontal battery branch.

C. Fixtures Back-to-Back in Battery (see Figure 925.C of this code). Fixtures installed back-to-back in a battery vented system shall comply with the following.

1. A fixture connected to a horizontal branch through a vertical drain and a sanitary tee shall be vented in accordance with §913.A of this code.

2. Back-to-back fixtures connected to a horizontal branch through a single vertical drain shall enter the vertical drain through a sanitary cross, and a common vent for each two fixtures shall be provided. The common vent shall be installed as a continuation of the vertical drain.

3. A fixture connected to a horizontal branch through a wye or combination wye and one-eighth bend installed in a horizontal position need not be individually vented.

4. Back-to-back fixtures connected to a horizontal branch through a double wye or combination double wye and one-eighth bend installed in the horizontal position need not be provided with a common vent at the connection to the horizontal branch, except for the last two fixtures upstream. The vent shall be installed in a vertical position at the interconnection of the fixture drains or downstream of the interconnection in accordance with the distance of fixture trap from vent requirements in Table 913.A of this code.

5. In spite of §§925.C.3 and 925.C.4 of this code, the following floor level fixtures discharging downstream from a water closet shall be individually vented:

- a. floor drains;
- b. bathtubs;
- c. showers;
- d. floor sinks;
- e. curbed cleaning facilities (i.e., floor-level mop sinks); and,
- f. similar type fixtures.

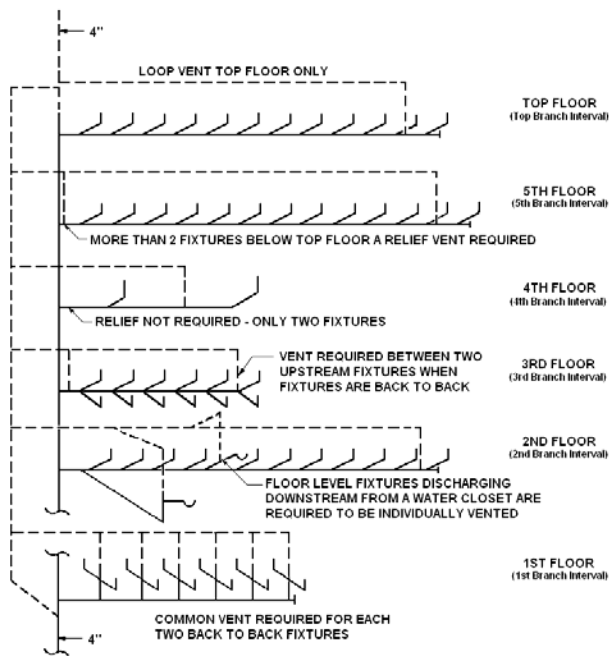


Figure 925.C—Battery Venting

**AUTHORITY NOTE:** Promulgated in accordance with R.S. 40:4(A)(7) and R.S. 40:5(2)(3)(7)(9)(16)(17)(20).

**HISTORICAL NOTE:** Promulgated by the Department of Health and Hospitals, Office of Public Health, LR 38:2865 (November 2012).

### §927. Pneumatic Ejectors

A. Relief vents from a pneumatic ejector shall be carried separately to the open air.

**AUTHORITY NOTE:** Promulgated in accordance with R.S. 40:4(A)(7) and R.S. 40:5(2)(3)(7)(9)(16)(17)(20).

**HISTORICAL NOTE:** Promulgated by the Department of Health and Hospitals, Office of Public Health, LR 38:2866 (November 2012).

### §929. Yoke Vents—Stacks of More Than 10 Branch Intervals

A. Soil and waste stacks in buildings having more than 10 branch intervals shall be provided with a yoke vent at each tenth interval installed, beginning with the top floor. The size of the yoke vent shall be equal to the size of the vent stack to which it connects. The lower end of each yoke vent shall connect to the soil or waste stack through a wye below the horizontal branch serving the floor, and the upper end shall connect to the vent stack through a wye not less than 3 feet (914 mm) above the floor and not less than 6 inches above the flood-level rim of the highest fixture served on the floor.

**AUTHORITY NOTE:** Promulgated in accordance with R.S. 40:4(A)(7) and R.S. 40:5(2)(3)(7)(9)(16)(17)(20).

**HISTORICAL NOTE:** Promulgated by the Department of Health and Hospitals, Office of Public Health, LR 38:2866 (November 2012).

### §931. Offset Vents

A. General. In buildings five or more stories in height, offsets in vertical drainage piping having less than a 45°

(0.785 rad) slope shall be vented in accordance with §931.B or §931.C, except as otherwise permitted by §727 of this code.

B. Separate Venting. Such offsets may be vented as two separate soil or waste stacks, namely the stack section below the offset and the stack section above the offset.

C. Offset Reliefs. Such offsets may be vented by installing a relief vent as a vertical continuation of the lower section of the stack or as a side vent connected to the lower section between the offset and next lower fixture or horizontal branch. The upper section of the offset shall be provided with a yoke vent. The diameter of the vents shall be not less than the diameter of the main vent, or of the soil and waste stack, whichever is the smaller.

**AUTHORITY NOTE:** Promulgated in accordance with R.S. 40:4(A)(7) and R.S. 40:5(2)(3)(7)(9)(16)(17)(20).

**HISTORICAL NOTE:** Promulgated by the Department of Health and Hospitals, Office of Public Health, LR 38:2866 (November 2012).

### §933. Main Vents to Connect at Base

A. All main vents or vent stacks shall connect full size at their base to the building drain within 10 pipe diameters of the main soil or waste pipe or to the main soil or waste pipe, at or below the lowest fixture branch. All vent pipes shall extend undiminished in size to the vent terminal, or shall be reconnected with the main soil or waste vent.

**AUTHORITY NOTE:** Promulgated in accordance with R.S. 40:4(A)(7) and R.S. 40:5(2)(3)(7)(9)(16)(17)(20).

**HISTORICAL NOTE:** Promulgated by the Department of Health and Hospitals, Office of Public Health, LR 38:2866 (November 2012).

### §935. Vent Headers

A. Stack vents and vent stacks may be connected into a common vent header at the top of the stacks and then terminate as required by this Chapter. This header shall be sized in accordance with the requirements of Table 937.B of this code, the number of units being the sum of all units on all stacks connected thereto, and the developed length being the longest vent length from the intersection at the base of the most distant stack to the vent terminal as a direct extension of one stack.

**AUTHORITY NOTE:** Promulgated in accordance with R.S. 40:4(A)(7) and R.S. 40:5(2)(3)(7)(9)(16)(17)(20).

**HISTORICAL NOTE:** Promulgated by the Department of Health and Hospitals, Office of Public Health, LR 38:2866 (November 2012).

### §937. Size and Length of Vents

A. Length of Vent Stacks. The length of the vent stack or main vent shall be its developed length from the lowest connection of the vent system with the soil stack, waste stack, or building drain to the vent stack terminal, if it terminates separately, or to the connection of the vent stack with the stack vent, plus the developed length of the stack-vent from the connection to the terminal, if the two vents are connected together with a single extension.



B. Size of Stack-Vents, Vent Stacks, Relief Vents, Individual Vents or Branch Vents. The diameter of a stack-vent, vent stack, relief vent, individual vent or branch vent shall not be less than one-half of the diameter of the drain served, but in no case less than 1 1/4 inches, and shall be determined from its length and the total of fixture units connected thereto, as provided in Table 937.B of this code. All water closets vents shall be a minimum of 2 inches in diameter. This shall not be interpreted to allow the alteration or elimination of the need for at least one 3-inch vent stack

or stack vent on the building drain as required under §905.C.1 of this code.

C. Size of Battery Vents. The diameter of a battery vent shall be not less than one-half the pipe size of the horizontal waste line it is venting, but in no case less than 1 1/2 inches, and shall be determined from its length and the total of fixture units connected thereto, as provided in Table 937.C of this code. The diameter and horizontal length of a battery vent shall in no case be less than permitted in Table 937.C of this code. (See §925 of this code).

Table 937.B Maximum Length of Vents (ft) (Other than Battery Vents) (See Table 937.C of this Code for Battery Venting)										
Size of Soil or Waste Stack (in)	Fixture Units Connected	Diameter of Vent Required (in)								
		1 1/4	1 1/2	2	2 1/2	3	4	5	6	8
1 1/4	2	30 ft	-	-	-	-	-	-	-	-
1 1/2	8	50 ft	150 ft	-	-	-	-	-	-	-
1 1/2	10	30 ft	100 ft	-	-	-	-	-	-	-
2	12	30 ft	75 ft	200 ft	-	-	-	-	-	-
2	20	26 ft	50 ft	150 ft	-	-	-	-	-	-
2 1/2	42	-	30 ft	100 ft	300 ft	-	-	-	-	-
3	10	-	30 ft	100 ft	200 ft	600 ft	-	-	-	-
3	30	-	-	60 ft	200 ft	500 ft	-	-	-	-
3	60	-	-	50 ft	80 ft	400 ft	-	-	-	-
4	100	-	-	35 ft	100 ft	260 ft	1000 ft	-	-	-
4	200	-	-	30 ft	90 ft	250 ft	900 ft	-	-	-
4	500	-	-	20 ft	70 ft	180 ft	700 ft	-	-	-
5	200	-	-	-	35 ft	80 ft	350 ft	1000 ft	-	-
5	500	-	-	-	30 ft	70 ft	300 ft	900 ft	-	-
5	1100	-	-	-	20 ft	50 ft	200 ft	700 ft	-	-
6	350	-	-	-	25 ft	50 ft	200 ft	400 ft	1300 ft	-
6	620	-	-	-	15 ft	30 ft	125 ft	300 ft	1100 ft	-
6	960	-	-	-	-	24 ft	100 ft	250 ft	1000 ft	-
6	1900	-	-	-	-	20 ft	70 ft	200 ft	700 ft	-
8	600	-	-	-	-	-	50 ft	150 ft	500 ft	1300 ft
8	1400	-	-	-	-	-	40 ft	100 ft	400 ft	1200 ft
8	2200	-	-	-	-	-	30 ft	80 ft	350 ft	1100 ft
8	3600	-	-	-	-	-	25 ft	60 ft	250 ft	800 ft
10	1000	-	-	-	-	-	-	75 ft	125 ft	1000 ft
10	2500	-	-	-	-	-	-	50 ft	100 ft	500 ft
10	3800	-	-	-	-	-	-	30 ft	80 ft	350 ft
10	5600	-	-	-	-	-	-	25 ft	60 ft	250 ft

Table 937.C Battery Vent Sizing Table Maximum Horizontal Length (ft)							
Soil or waste pipe diam. (in)	Maximum no. Fixture units	Diameter of circuit or loop vent (in)					
		1 1/2	2	2 1/2	3	4	5
2	3	15 ft	40 ft	-	-	-	-
2 1/2	6	10 ft	30 ft	-	-	-	-
3	10	-	20 ft	40 ft	100 ft	-	-
4	80	-	7 ft	20 ft	52 ft	200 ft	-
5	180	-	-	-	16 ft	70 ft	200 ft

AUTHORITY NOTE: Promulgated in accordance with R.S. 40:4(A)(7) and R.S. 40:5(2)(3)(7)(9)(16)(17)(20).

HISTORICAL NOTE: Promulgated by the Department of Health and Hospitals, Office of Public Health, LR 38:2866 (November 2012).

**§939. Additional Provisions**

A. Additional provisions for vents are contained in Chapter 13, Medical Facilities Plumbing Systems of this code.

AUTHORITY NOTE: Promulgated in accordance with R.S. 40:4(A)(7) and R.S. 40:5(2)(3)(7)(9)(16)(17)(20).

HISTORICAL NOTE: Promulgated by the Department of Health and Hospitals, Office of Public Health, LR 38:2867 (November 2012).

**§941. Additional Information**

A. Additional information for vents is contained in Chapter 18 (Appendices) and §1807 (Appendix C, Illustrations) of this code. Such additional information in Chapter 18 of this code shall not be construed as superceding any pertinent regulation(s) contained in LAC Chapters 1-17 of this code.

AUTHORITY NOTE: Promulgated in accordance with R.S. 40:4(A)(7) and R.S. 40:5(2)(3)(7)(9)(16)(17)(20).

HISTORICAL NOTE: Promulgated by the Department of Health and Hospitals, Office of Public Health, LR 38:2867 (November 2012).

**Chapter 10. Traps****§1001. General**

A. Scope. The provisions of this Chapter shall govern the materials and installation of traps.

B. Trap Seal. Each fixture trap shall have a water seal of not less than 2 inches (51 mm) and not more than 4 inches (102 mm), except where a deeper seal is required by the plumbing official for special conditions.

C. Trap Level and Protection. Traps shall be set level with respect to their water seals.

D. Traps Underground. Underground traps, except "P" traps into which floor drains with removable strainers discharge, shall be provided with accessible and removable cleanouts.

E. Prohibited Traps. The following traps (or types of traps) are prohibited from use:

1. a trap which depends for its seal upon the action of movable parts;
2. "S" traps;
  - a. Exception. Water closets, clinical sinks, urinals and similar fixtures shall be allowed to be "S" trapped if the fixture has an integral trap which is automatically and properly refilled using an approved device.
3. bell traps;
4. crown-vented traps (see §913.D of this code);
5. baffled or partition traps other than stainless steel, glass, plastic or similar corrosion resistant materials;
6. tubular metallic traps of less than 20 gage [0.0320 inch (0.813 mm)] thickness; and,

7. running traps.

a. Exceptions

i. A running trap with cleanout may be allowed on condensate waste lines (see §1305.I of this code).

ii. A running trap may be authorized for certain floor level fixtures installed on a Combination Waste and Vent System when plans and specifications have been specially approved by the state health officer under the requirements of Chapter 12 (Alternate Designed Plumbing Systems) of this code. See guidance for same under §1811.C.4 of this code.

F. Double Trapping. A fixture shall not be double trapped.

1. Exception. Fixtures in mobile/manufactured homes and travel trailers are allowed to be double trapped when a trailer trap is required to be placed in the building sewer/sewer lateral as per §1003.E, §1515.J, §1523.A, §1613.J or §1623.A of this code.

G. Unions (Threaded). Unions may be used in the trap seal and on the inlet side of the trap. Unions shall have metal-to-metal seats.

H. Fixture Trap Required, Location, and Number of Traps Per Fixture. The requirement for a fixture trap and the number of traps per fixture shall be in conformance with the following.

1. Plumbing fixtures, excepting those having integral traps, shall be separately trapped by a water seal trap, placed as close to the fixture outlet as possible.

2. A combination plumbing fixture may be installed on one trap, if one compartment is not more than 6 inches (152 mm) deeper than the other and the waste outlets are not more than 30 inches (762 mm) apart.

3. One trap may be installed for a set of not more than three single-compartment sinks or laundry trays or three lavatories immediately adjacent to each other in the same room, if the waste outlets are not more than 30 inches (762 mm) apart and the trap is centrally located when three compartments are installed.

I. Distance of Trap Weir from Fixture Outlet. The vertical distance from the fixture outlet to the trap weir, or from the outlet of an integrally trapped water closet or similar fixture to the horizontal piping connecting the fixture to its vent, shall not exceed 24 inches (610 mm).

1. Exception. Washing Machine Pumped Waste Drain. The vertical distance from the vertical standpipe inlet receiving the pumped waste discharge from a washing machine (laundry) to the trap weir shall be a minimum of 30 inches (762 mm) and a maximum of 48 inches (1219 mm), with the vertical standpipe inlet terminating a minimum of 34 inches (864 mm) above finished floor or in accordance with the manufacturer's recommendation.

AUTHORITY NOTE: Promulgated in accordance with R.S. 40:4(A)(7) and R.S. 40:5(2)(3)(7)(9)(16)(17)(20).

HISTORICAL NOTE: Promulgated by the Department of Health and Hospitals, Office of Public Health, LR 38:2867 (November 2012).

### **§1003. Type and Size of Traps and Fixture Drains**

A. Trap Size. The size (nominal diameter) of a trap for a given fixture shall be sufficient to drain the fixture rapidly but in no case less than given in Table 723.A of this code.

B. Relation to Fixture Drains. A trap shall not be larger than the fixture drain to which it is connected.

C. Type of Traps. Traps shall conform with the following requirements.

1. Fixture traps shall be self-cleaning, other than integral traps and drum traps, without partitions or movable parts, except as specifically approved in other Sections of this Chapter.

2. Slip joints may be used on both sides of the trap and in the trap seal.

3. A trap which is integral with the fixture shall have a uniform interior and a smooth waterway.

D. Drum Traps. The use of drum traps shall comply with the following requirements:

1. Drum traps shall be limited to special fixtures wherein the capture of solids (e.g., broken teeth, fillings, etc., from dental cuspidors) is desired so that such solids can be removed before they escape into the downstream drainage system. Drum traps are subject to approval by the plumbing official. The body of the drum trap shall be not

less than 4-inch diameter and shall have a water seal of not less than 2 inches (51 mm).

2. The trap screw of the drum trap/drum trap cover shall be one size less than the body of the drum trap's diameter.

E. Trailer Traps. Mobile/manufactured homes and travel trailers shall be provided with a trailer trap in the building sewer/sewer lateral immediately downstream of the mobile/manufactured home or travel trailer drain outlet connection. The trailer trap shall be individually vented and the vent shall be located downstream of the trap at a distance in accord with Table 913.A, Section 913.D and Section 1001.E.4 of this code. Running traps are prohibited for this installation. See diagram under §1523.A or §1623.A of this code.

1. Exception. The trailer trap for a mobile/manufactured home or travel trailer is not required to be provided with an individual vent if the mobile/manufactured home or travel trailer is connected to a park drainage system constructed in accord with §1613.G or §1515.G of this code and the building sewer/sewer lateral is no longer than 30 feet (9144 mm) from the main park drainage sewer main. For this individual vent exception to apply, the building sewer/sewer lateral shall enter the main park drainage sewer main on the horizontal such that an "S" trap or an effective "S" trap is not created. See §§1515.J and 1613.E.1 of this code.

- APPROVED MATERIALS FOR TRAP & VENT:  
 (1) CAST IRON PIPE & FITTINGS.  
 (2) ABS OR PLASTIC PIPE & FITTINGS (SCH. 40)

- APPROVED SEWER PIPES:  
 (1) CAST IRON SEWER PIPE.  
 (2) VITRIFIED CLAY SEWER PIPE.  
 (3) APPROVED PLASTIC PIPE AND FITTINGS (MIN. SDR 35)  
 (NOTE: FROM A POINT AT LEAST 3 FEET OUTSIDE THE  
 EDGE OF THE TRAILER TO THE SEWAGE SYSTEM.)

- NOTES: (1) ASTM D2729 IS NOT APPROVED FOR  
 ANY PART OF THE SYSTEM.  
 (2) INSTALL 4" CLEANOUT FOR TRAILER  
 CONNECTION AND TERMINATE 3 TO 6  
 INCHES ABOVE GRADE.  
 (3) INSTALL 3" MALE ADAPTER IN TRAILER  
 CONNECTION.

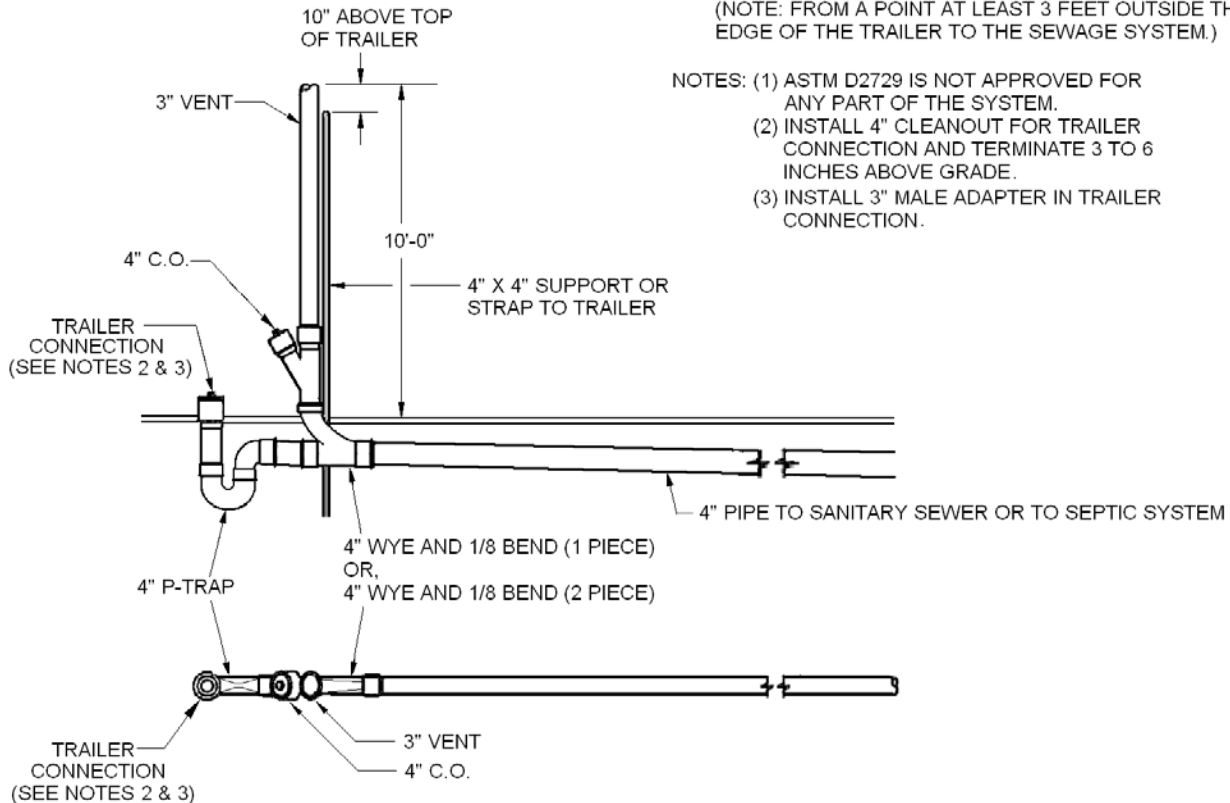


Figure 1003.E—Trailer Trap and Vent

AUTHORITY NOTE: Promulgated in accordance with R.S. 40:4(A)(7) and R.S. 40:5(2)(3)(7)(9)(16)(17)(20).

HISTORICAL NOTE: Promulgated by the Department of Health and Hospitals, Office of Public Health, LR 38:2868 (November 2012).

**§1005. Interceptors and Separators**

A. When required. Interceptors or separators shall be provided for the proper handling of liquid wastes containing grease, oil, flammable waste, sand, solids or other ingredients harmful to the building drainage system, the sewerage system or sewage treatment plant or processes except when, in the opinion of the plumbing official, they are not necessary.

B. Size and Type. The size, type and location of each interceptor or separator shall be approved by the plumbing official.

C. Type of Waste. No wastes other than those requiring treatment or separation shall be discharged into any interceptor or separator except where otherwise specifically permitted.

D. Grease Traps, Grease Interceptors, and Large Capacity Grease Interceptors. An approved type grease trap, grease interceptor, or large capacity grease interceptor complying with the provisions of this Section shall be installed in the waste line leading from sinks, drains and other fixtures or equipment in establishments such as restaurants, cafes, lunch counters, cafeterias, bars and clubs, hotels, hospitals, sanitariums, factory, school or day care center kitchens, markets, or other establishments where grease may be introduced into the drainage or sewage system in quantities that can affect line stoppage or hinder sewage treatment or the functioning of an individual sewerage system, except when, in the opinion of the plumbing official, they are not necessary.

E. Oil Separators. An oil separator shall be installed in the drainage system section of the system where, in the opinion of the plumbing official, a hazard exists or where oils or other flammables can be introduced or admitted into the drainage system by accident or otherwise.

F. Sand Interceptors. Sand and similar interceptors for heavy solids shall have a water seal of not less than 2 inches (51 mm).

G. Venting Interceptors. Interceptors shall be so designed that they will not become air bound if closed covers are used. Each interceptor shall be properly vented.

H. Accessibility of Interceptors. Each interceptor shall be so installed as to provide ready accessibility to the cover and means for servicing and maintaining the interceptor in working and operating condition. The use of ladders or the removal of bulky equipment in order to service interceptors shall constitute a violation of accessibility.

I. Water Connection. If permitted by the plumbing official, any water connection for cooling or operating an interceptor shall be such that backflow cannot occur.

J. Special Occupancy Provisions. Laundries, bottling plants and slaughter houses shall be provided with an interceptor or separator in conformance with the following.

1. Laundries. Laundries shall be provided with an interceptor as follows.

a. Interceptor. Commercial laundries shall be equipped with an interceptor having a removable wire basket or similar device that will prevent strings, rags, buttons, or other materials detrimental to the sewerage system from passing into the drainage system.

b. Intercepting Basket/Device. The basket or other device shall prevent passage into the drainage system of solids 1/2-inch (12.7 mm) or larger in size. The basket or device shall be removable for cleaning purposes.

2. Bottling Plants. Bottling plants shall discharge their process wastes into an interceptor which will provide for the separation of broken glass or other solids, before discharging liquid wastes into the drainage system.

3. Slaughter House Drains. Slaughtering room drains shall be equipped with separators which shall prevent the discharge into the drainage system of feathers, entrails and other materials likely to clog the drainage system.

K. Food Service. The following special requirements apply to the handling of organic wastes of food origin.

1. Commercial Food-Waste Grinders. Where commercial food-waste grinders are installed, the waste from those units shall discharge through a grease trap of an approved design for this use.

2. Wash Racks. Every wash rack and/or floor or slab used for cleaning containers and equipment exposed to organic wastes of food origin shall be adequately protected against storm or surface water and shall drain or discharge into a grease trap of an approved design for this use.

L. Maintenance. Grease traps, grease interceptors, large capacity grease interceptors, and other types of interceptors and separators shall be maintained in conformance with the following.

1. Grease Traps and Grease Interceptors. Grease traps, grease interceptors, and large capacity grease interceptors shall be maintained in efficient operating condition by periodic removal of the accumulated grease. No such collected grease shall be introduced into any drainage piping or sewerage system.

2. Interceptors and Separators in General. Interceptors and separators of all types shall be maintained in efficient operating condition by periodic removal of accumulated material for which the interceptor or separator has been designed. No such collected material shall be introduced into any drainage piping or sewerage system.

M. Special Type Interceptors/Separators. The plumbing official may require the submittal of drawings and other pertinent information for any interceptor/separator designed for a special or unusual purpose/use.

N. Procedures for Design, Construction and Installation of Interceptors and Separators [formerly Appendix M - Procedures for Design, Construction and Installation of Interceptors and Separators]. The provisions of this Subsection shall apply to the design, construction, installation and testing of interceptors and separators required in accordance with Subsections A - M of §1005 of this code.

1. Definitions. Definitions contained in Chapter 2 of this code shall also apply to this Section except where the following special definitions shall apply.

*Bottling Plant Separator*—an *interceptor* designed to separate and retain broken glass and other solids.

*Grease Interceptor*—an *interceptor* of less than 125 gallon capacity which is designed and installed so as to separate and retain grease. Typically identified by flow rate and/or grease capacity and generally installed indoors adjacent to the plumbing fixtures they serve. (See §1005.N.6 of this code for design and sizing requirements.)

*Grease Trap*—an *interceptor* of at least 125 gallon capacity which is designed and installed to separate and retain grease. Typically identified by liquid holding capacity (volume) and generally installed below *grade<sub>(G)</sub>* outdoors with provisions for above *grade<sub>(G)</sub>* accessibility for cleaning purposes. (See §1005.N.3 of this code for sizing requirements and §1005.N.4 of this code for design requirements.)

*Large Capacity Grease Interceptor*—an *interceptor* of at least 125 gallon capacity conforming to ASME A 112.14.3 or PDI-G101 which is designed and installed to separate and retain grease. Generally manufactured to be installed above or below *grade<sub>(G)</sub>* either indoors or outdoors. (See §1005.N.3 of this code for sizing requirements and §1005.N.5 of this code for design requirements.)

*Laundry Trap*—an *interceptor* designed to separate and retain lint, strings, rags, buttons or other similar materials which may be discharged from laundries.

*Oil Separator*—an *interceptor* designed to separate and retain waste oil and other petroleum products.

*Sand Interceptor*—an *interceptor* designed to separate and retain sand, gritty material or other types of heavy solids.

*Slaughter House Separator*—an *interceptor* designed to separate and retain feathers, entrails and other similar substances.

*Special Type Separator*—an *interceptor* designed to separate and retain deleterious, hazardous or undesirable matter from normal wastes for proper disposal, rendering, or recycling.

2. General Regulations. The following general regulations are applicable to interceptors and separators.

a. Size and Type. The size and type of each interceptor or separator shall be in accordance with the requirements of this Section and shall be approved by the plumbing official.

b. Location. The location of each interceptor or separator shall be approved by the plumbing official.

c. Prior Approval. No interceptor or separator shall be installed until its design, size, location and venting has been approved by the plumbing official.

d. Cleanout on Discharge Line. A two-way cleanout shall be provided on the discharge line immediately downstream of all interceptors.

e. Grease Traps/Grease Interceptors/Large Capacity Grease Interceptors. When it has been determined under §1005.D of this code that a trap or interceptor is required, the following regulations apply to the use of a grease trap or large capacity grease interceptor versus the allowance of the use of a grease interceptor.

i. A grease trap or large capacity grease interceptor shall be required in all instances of new construction or substantial renovation of buildings or facilities. In addition, a grease trap or large capacity grease interceptor shall be required for existing buildings or facilities when a proper installation can be performed without the need to break up a concrete slab.

ii. At the discretion of the plumbing official, a grease interceptor may be allowed in lieu of a grease trap or large capacity grease interceptor when the conditions for a grease trap/large capacity grease interceptor installation do not exist or cannot easily be met. For example, when:

(a) new construction, substantial renovation of buildings or facilities is not being performed and a concrete slab would have to be broken at the existing building or facility for the proper installation of a grease trap;

(b) an outside, unpaved area surrounding the building where a grease trap could be installed is available; however, it is determined that the area is too far away from the plumbing fixtures that the grease trap would be servicing; or,

(c) the installation of a grease trap is unfeasible such as when servicing a kitchen which is located on the upper floors of a multistoried building.

3. Minimum Capacity of Grease Traps and Large Capacity Grease Interceptors. The minimum required capacity of grease traps and large capacity grease interceptors shall be determined based upon the maximum number of persons served during the largest meal period in accordance with the following:

a. General. Grease traps and large capacity grease interceptors should be designed to be large enough to allow the water contained within it to remain cold since only cold water separates grease. In addition, grease traps and large capacity grease interceptors should be designed to be large enough so that they require cleaning at a frequency no more often than once per month.

b. Without Garbage Grinder. The minimum capacity for applications without a garbage grinder shall not be less than 125 gallons below the static water level. This capacity is sufficient to hold the flow from one meal long enough to accomplish proper grease separation when serving up to 50 people during a single meal period. When over 50 people are served during a single meal period, the minimum capacity of the grease trap or large capacity grease interceptor shall be increased beyond 125 gallons based upon at least an additional 2 1/2 gallons per person beginning with the 51<sup>st</sup> person served and greater.

c. With Garbage Grinder. When a garbage grinder is connected (see §1005.K.1 of this code), the grease trap or large capacity grease interceptor shall have a minimum capacity of no less than 500 gallons below the static water level. This capacity is sufficient to hold the flow from one meal long enough to accomplish proper grease separation when serving up to 50 people during a single meal period. When a garbage grinder is connected and over 50 people are served during a single meal period, the minimum grease trap capacity shall be increased beyond 500 gallons based upon at least an additional 2 1/2 gallons per person beginning with the 51<sup>st</sup> person served and greater.

d. Alternate Sizing Methods. For informational purposes only, alternate sizing methods may be found in Figures 9, 10, and 11 in Section 1807 of this code.

4. Grease Traps. The following regulations are applicable to the design and installation of grease traps.

a. The minimum required capacity of grease traps shall be determined based upon the maximum number of persons served during the largest meal period in accordance with §1005.N.3 of this code.

b. If a grease trap must be installed within an enclosed building, any access covers shall be gasketed to prevent the intrusion of odors into the building.

c. A one compartment grease trap is acceptable; however, a two compartment, or a one compartment grease trap with a baffle wall between the inlet and outlet, is preferred.

d. The grease trap shall be placed as close to the plumbing fixture(s) discharging greasy waste as possible, but preferably on the outside of the building when feasible.

e. The minimum diameter of the outlet pipe shall not be less than 4 inches.

f. A minimum of one foot of air space shall be provided above the static water level.

g. Venting. The following regulations are applicable to the venting of grease traps:

i. The grease trap outlet shall be properly vented to prevent the trap from siphoning itself out. Any internally vented outlet line shall have the vent terminal extended to within 2 inches of the bottom of the access cover to prevent grease from escaping the grease trap through the open vent terminal.

ii. For those grease traps having a gasketed cover, the grease trap outlet line shall not be allowed to be internally vented. In this case, the outlet line itself shall have a 2-inch vent pipe properly installed.

h. The invert of the grease trap outlet opening, at the point where water exits the grease trap, shall be located at a maximum of 6 inches and a minimum of 4 inches from the floor of the grease trap. This requirement also applies to any intermediate outlets in multi-compartment grease traps. The invert of the inlet shall be at least 3 inches above the invert of the outlet.

i. On unbaffled single compartment grease traps, a 90° ell shall be used on the inlet and shall terminate 6 inches below the static water level. On baffled single compartment grease traps, a baffle wall shall be placed between the inlet and outlet. The inlet shall discharge into the grease trap at a level at least 6 inches below the top of the baffle wall. The baffle wall shall extend from 2 inches below the static water

level to the bottom of the grease trap such that incoming water will have to overflow above the top of the baffle wall in order to reach the outlet.

j. The horizontal distance between the inlet and outlet piping in the grease trap should be sufficient to allow gravity-differential separation to the grease so that it will not escape through the outlet. The minimum horizontal distance shall be 24 inches.

k. Access/Covers. The following regulations are applicable to the access to and the covers for grease traps:

i. Access from the top of the grease trap shall be provided by an easily removable cover above an access opening of at least 20 inches square or 24 inches round. Additional access opening/covers shall be provided as necessary to provide accessibility to each compartment in multi-compartment or multi-baffled arrangements as well as access to both the inlet and outlet. Access opening covers shall be above or at grade<sub>(G)</sub> to provide ready accessibility.

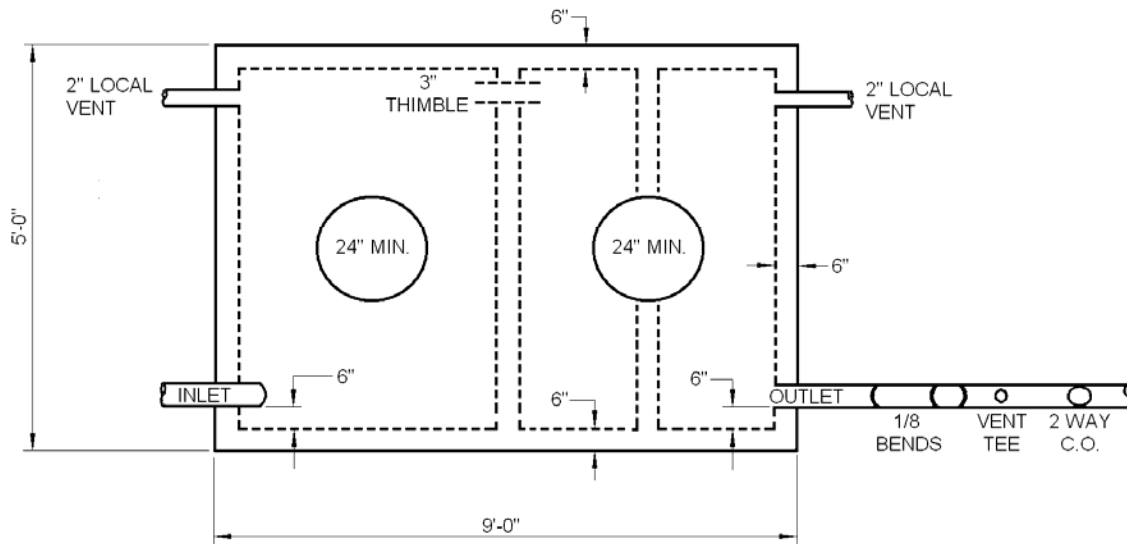
ii. Each access cover shall be designed so that it cannot slide, rotate, or flip when properly installed in order that the opening is not unintentionally exposed. (The intention is that a child-resistant cover be provided. Especially for lightweight covers, mechanical fasteners are recommended to augment the safety of and ensure positive closure of the cover.)

l. No water jacketed grease trap shall be approved or installed.

m. Each grease trap shall have an approved water seal of not less than 2 inches in depth or the diameter of its outlet, whichever is greater.

n. Abandoned grease traps shall be pumped and filled as required for abandoned septic tanks in accord with LAC 51:XIII.715.V.

NOTE: IF 3" THIMBLE IS USED AS ILLUSTRATED, ONE 2" LOCAL VENT MAY BE ELIMINATED



PUBLIC HEALTH—SANITARY CODE

Figure 1005.N.4A (1 of 2)—Grease Trap (top view)

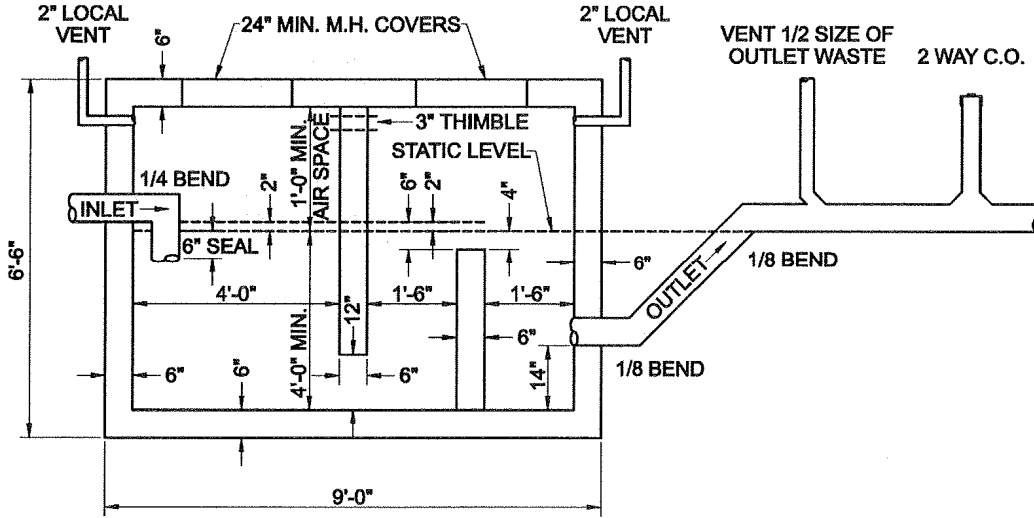
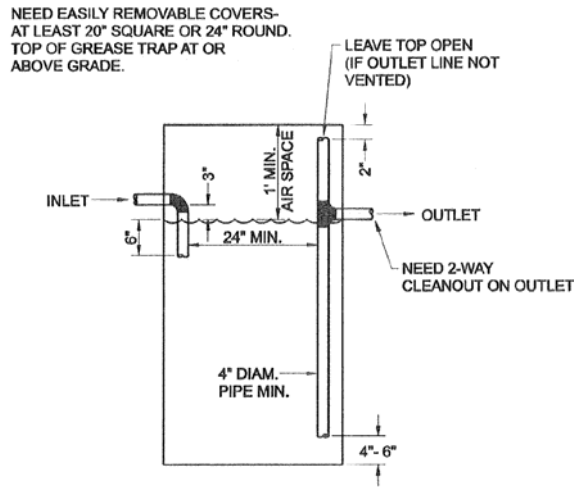


Figure 1005.N.4A (2 of 2)—Grease Trap (side view)



Min. volume below invert of outlet = 125 gallons

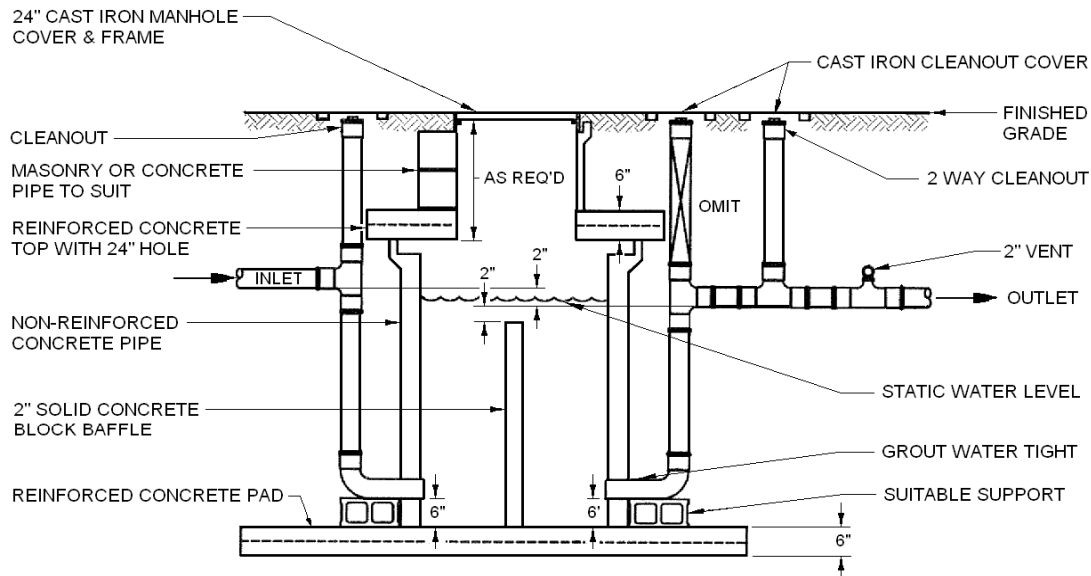
= 2' x 2' x 4' water depth  
(would have to be built  
2' x 2' x 5' in order to  
give 1' air space above  
water line)

or = 2' x 3' x 3' water depth\*  
(would have to be built  
2' x 3' x 4' in order to  
give 1' air space above  
water line)

(\* This would be preferred in order  
to keep inlet & outlet at least 24"  
apart from each other.)

Figure 1005.N.4B—Grease Trap (sanitary details only)





NOTES:

1. THE BOTTOM OF THE INLET PIPE SHALL BE NOT LESS THAN TWO INCHES ABOVE THE BOTTOM OF THE OUTLET PIPE.
2. THE BOTTOM OF THE OUTLET PIPE SHALL BE TWO INCHES ABOVE THE TOP OF THE BAFFLE WALL.
3. TRAP INDICATED ABOVE IS FOR CONCRETE PIPE CONSTRUCTION. ALTERNATE MATERIAL AND METHODS OF INSTALLATION MUST BE SUBMITTED FOR APPROVAL PRIOR TO INSTALLATION.

Figure 1005.N.4C—Grease Trap

5. Large Capacity Grease Interceptors. The following design regulations are applicable to large capacity grease interceptors.

a. Large capacity grease interceptors shall be evaluated, tested, and certified for conformance with ASME A 112.14.3 or PDI-G101.

b. The minimum required capacity of large capacity grease interceptors shall be determined based upon the maximum number of persons served during the largest meal period in accordance with §1005.N.3 of this code.

c. Grease interceptors shall be maintained in efficient operating condition by periodic removal of the accumulated grease. No such collected grease shall be introduced into any drainage piping or sewerage system.

d. Each grease interceptor shall have an approved water seal of not less than 2 inches in depth or the diameter of its outlet, whichever is greater. The grease interceptor outlet shall be properly vented to prevent the trap from siphoning itself out.

6. Grease Interceptors. The following design regulations are applicable to grease interceptors:

a. When specially allowed by the plumbing official pursuant to §1005.N.2.e of this code, an approved type

grease interceptor complying with ASME A 112.14.3 or PDI-G101 and the provisions of this Paragraph may be installed in the waste line leading from sinks, drains and other fixtures or equipment in establishments such as restaurants, cafes, lunch counters, cafeterias, bars and clubs, hotels, hospitals, sanitariums, factory, school or day care center kitchens, markets, or other establishments where grease may be introduced into the drainage or sewerage system in quantities that can affect line stoppage or hinder sewage treatment or the functioning of an individual sewerage system, except when, in the opinion of the plumbing official, they are not necessary.

b. The minimum required size of grease interceptors shall be determined based upon fixture discharge rate (gpm) and grease retention capacity (pounds) in accordance with Figure 1005.N.6 of this code (see also §1005.N.6.h of this code); however, in no case shall a grease interceptor be installed which has an approved rate of flow of less than 20 gallons per minute, except when specially approved by the plumbing official.

c. Each plumbing fixture or piece of equipment connected to a grease interceptor shall be provided with an approved type flow control or restricting device installed in a readily accessible and visible location in the tailpiece or drain outlet of each such fixture. Flow control devices shall

be so designed that the flow through such device or devices shall at no time be greater than the rated capacity of the grease interceptors. No flow control device having adjustable or removable parts shall be approved.

d. Each grease interceptor that is rated shall be stamped or labeled by the manufacturer with an indication of its full discharge rate in gallons per minute (gpm). Each grease interceptor allowed to be installed under the provisions of this Paragraph shall have an approved rate of flow which is not less than that given in Table 1005.N.6 of this code based upon the total flow expected in gpm from the total number of connected fixtures (i.e., each grease interceptor shall be rated equal to or greater than the incoming flow). The total capacity, in gallons, from all fixtures discharging into any such grease interceptor shall not exceed two and one-half (2-1/2) times the certified gallon per minute (gpm) flow rate of the grease interceptor as per Table 1005.N.6 of this code.

i. Any grease interceptor installed with the inlet more than 4 feet lower in elevation than the outlet of any fixture discharging into such grease interceptor shall have an approved rate of flow which is not less than 50 percent greater than that given in Table 1005.N.6 of this code.

ii. For the purpose of this Paragraph, the term "fixture" shall mean and include each plumbing fixture, appliance, apparatus or other equipment required to be connected to or discharge into a grease interceptor by any provision of this Paragraph.

e. Each fixture discharging into a grease interceptor shall be trapped and vented in an approved manner. An approved type grease interceptor may be used as a fixture trap for a single fixture when the horizontal distance between the fixture outlet and the grease interceptor does not exceed 4 feet and the vertical tailpipe or drain does not exceed 2 1/2 feet.

f. Grease interceptors shall be maintained in efficient operating condition by periodic removal of the accumulated grease. No such collected grease shall be introduced into any drainage piping or sewerage system.

g. Each grease interceptor shall have an approved water seal of not less than 2 inches in depth or the diameter of its outlet, whichever is greater. The grease interceptor outlet shall be properly vented to prevent the trap from siphoning itself out.

h. When grease interceptors are allowed to be installed by the plumbing official in commercial kitchens, the recommended sizing criteria is provided in Table 1005.N.6 of this code below.

<b>Required Rate of Flow Per Minute, Gallons</b>	<b>Grease Retention Capacity, Pounds</b>
20	40
25	50
35	70
50	100

<b>Steps</b>	<b>Formula</b>	<b>Example</b>
1	Determine cubic content of fixture by multiplying length x width x depth.	A sink 48" long by 24" wide by 12" deep. Cubic content 48 x 24 x 12 = 13,824 cubic inches
2	Determine capacity in gallons. 1 gal = 231 cubic inches	Contents in gallons 13,824 ÷ 231 = 59.8 gallons
3	Determine actual drainage load. The fixture is normally filled to about 75 percent of capacity with water. The items being washed displace about 25 percent of the fixture content, thus actual drainage load = 75 percent of fixture capacity.	Actual Drainage Load 0.75 x 59.8 = 44.9 gallons
4	Determine flow rate and drainage period. In general, good practices dictate a 1-minute drainage period; however, where conditions permit, a 2-minute drainage period is acceptable. Drainage period is the actual time required to completely drain the fixture. Flow rate = Actual Drainage Load ÷ Drainage Period	Calculate flow rate for 1-minute period 44.9 ÷ 1 = 44.9 gpm Flow rate Two-minute period 44.9 ÷ 2 = 22.5 gpm Flow Rate
5	Select interceptor which corresponds to the flow rate calculated. Note: Select next larger size when flow rate falls between two sizes listed.	For 1-minute period, 44.9 gpm requires PDI size "50". For 2-minute period, 22.5 gpm requires PDI size "25".

**Figure 1005.N.6**

7. Oil Separators. The following regulations are applicable to oil separators.

a. All repair garages and gasoline stations with grease racks or grease pits, and all factories which have oily wastes as a result of manufacturing, storage, maintenance, repair, or testing processes shall be provided with an oil separator which shall be connected to all necessary floor drains. The separation of the vapor compartment shall be independently vented to the outer air. If two or more separation or vapor compartments are used, each shall be vented to the outer air or may connect to a header which is installed at a minimum of 6 inches above the spill line of the lowest floor drain and vented independently to the outer air. The minimum size of a flammable vapor vent shall not be less than 2 inches, and when vented through a sidewall, the vent shall not be less than 10 feet above the adjacent level at an approved location. The interceptor shall be vented on the sewer side and this vent shall not connect to a flammable vapor vent. All oil interceptors shall be provided with gastight cleanout covers which shall be readily accessible. The waste line shall not be less than 3 inches in diameter with a full-size two-way cleanout brought to grade<sub>(G)</sub>. When an interceptor is provided with an overflow, it shall be provided with an overflow line (not less than 2 inches in diameter) to an approved waste oil tank having a minimum capacity of 550 gallons and meeting the requirements of the appropriate authority. The waste oil from the separator shall

flow by gravity or shall be pumped to a higher elevation by an automatic pump. Pumps shall be adequately sized and accessible. Waste oil tanks shall have a 2-inch minimum pumpout connection at grade<sub>(G)</sub> and a 1 1/2-inch minimum vent to atmosphere at an approved location at least 10 feet above grade<sub>(G)</sub>.

b. Each manufactured oil interceptor that is rated shall be stamped or labeled by the manufacturer with an indication of its full discharge rate in gallons per minute (gpm). The full discharge rate to such an oil interceptor shall be determined at full flow. Each oil interceptor shall be rated equal to or greater than the incoming flow and shall be provided with an overflow line to an underground tank.

i. Oil interceptors not rated by the manufacturer shall have a depth of not less than 2 feet below the invert of the discharge drain. The outlet opening shall have not less than an 18-inch water seal and shall have a minimum capacity as follows:

(a). where not more than three motor vehicles are serviced and/or stored, oil interceptors shall have a minimum capacity of 6 cubic feet, and 1 cubic foot of capacity shall be added for each vehicle up to 10 vehicles; and

(b). above 10 vehicles, the plumbing official shall determine the size of the oil interceptor required. Where vehicles are serviced only and not stored, oil interceptor capacity shall be based on a net capacity of 1 cubic foot for each 100 square feet of surface to be drained into the oil interceptor, with a minimum of 6 cubic feet.

c. A combination oil and sand interceptor may be installed when the design is approved in writing by the plumbing official.

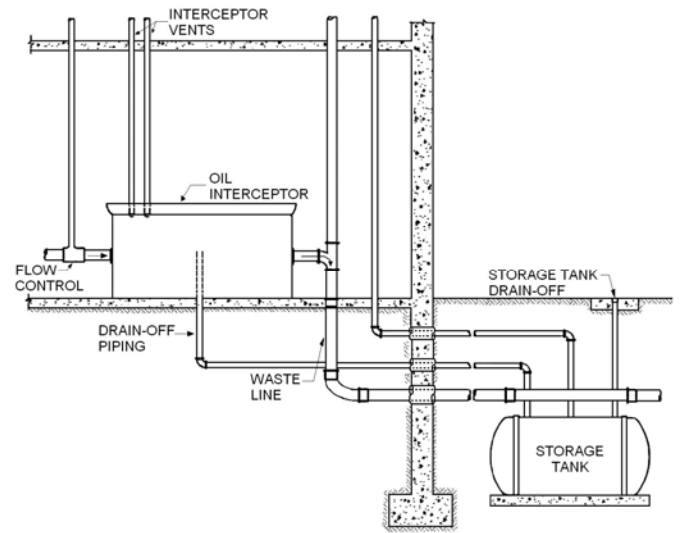


Figure 1005.N.7A—Oil Separator

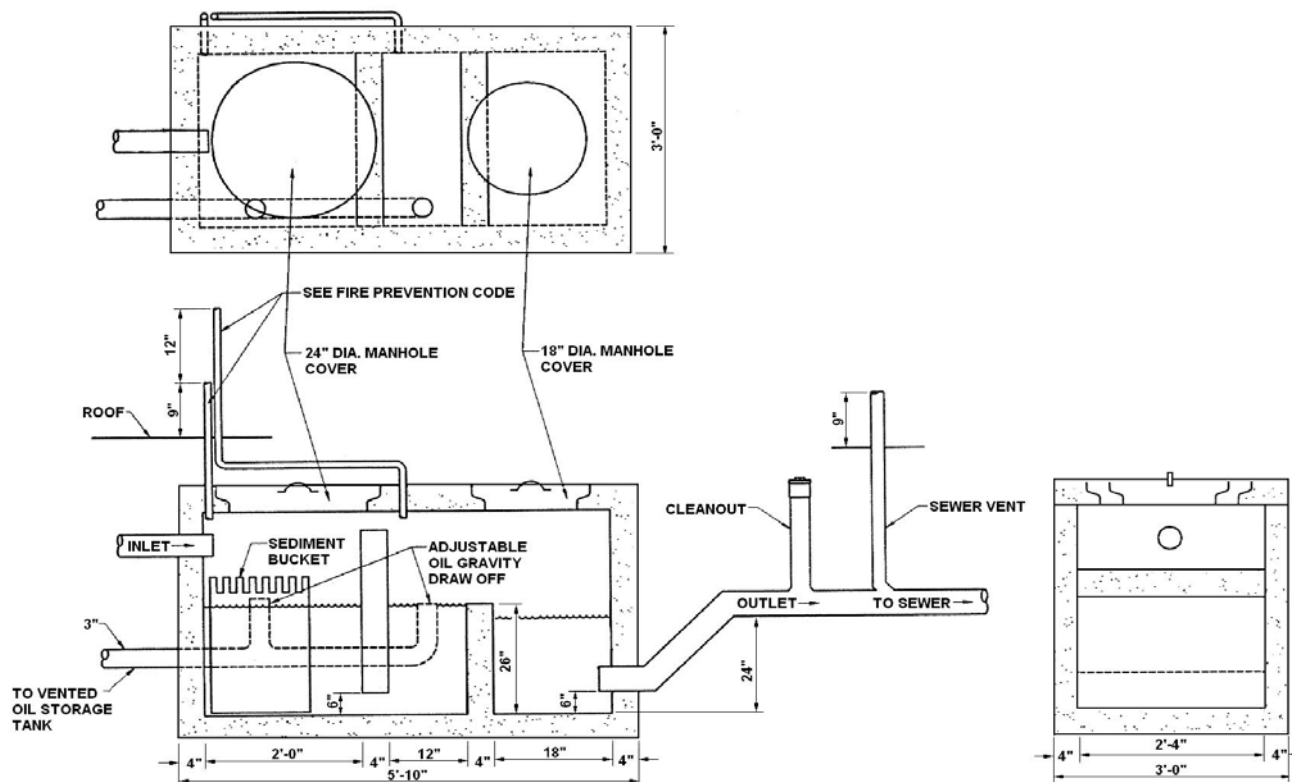


Figure 1005.N.7B—Oil Separator Details

8. Sand Interceptors. The following regulations are applicable to sand interceptors.

a. Multiple floor drains may discharge into one sand interceptor.

b. Sand interceptors shall be built of brick or concrete, prefabricated coated steel, or other watertight material. The sand interceptor shall have an interior baffle for full separation of the interceptor into two sections. The outlet pipe shall be the same size as the inlet, the minimum

being 3 inches, and the baffle shall have two openings of the same diameter as the outlet pipe and at the same invert as the outlet pipe. These openings shall be staggered so that there cannot be a straight line flow between any inlet pipe and the outlet pipe. The invert of the inlet pipe shall be no lower than the invert of the outlet pipe.

i. The sand interceptor shall have a minimum dimension of 2-feet square for the net free opening of the inlet screen and a minimum depth under the invert of the outlet pipe of 24 inches.

ii. For each 5 gallons per minute flow or fraction thereof over 20 gallons per minute, the area of the sand interceptor inlet section is to be increased by 1 square foot. The outlet section shall at all times have a minimum area of 50 percent of the inlet sections.

iii. The outlet section shall be covered by a solid removable cover set flush with the finished floor, and the inlet section shall have an open grating set flush with the finished floor and suitable for the traffic in the area in which it is located.

c. Sand and similar interceptors for every solid shall be so designed and located as to be readily accessible for cleaning, shall have a water seal of not less than 6 inches, and shall be vented.

d. Alternate designs for construction or baffling of sand interceptors complying with the intent of this code may be submitted to the plumbing official for approval.

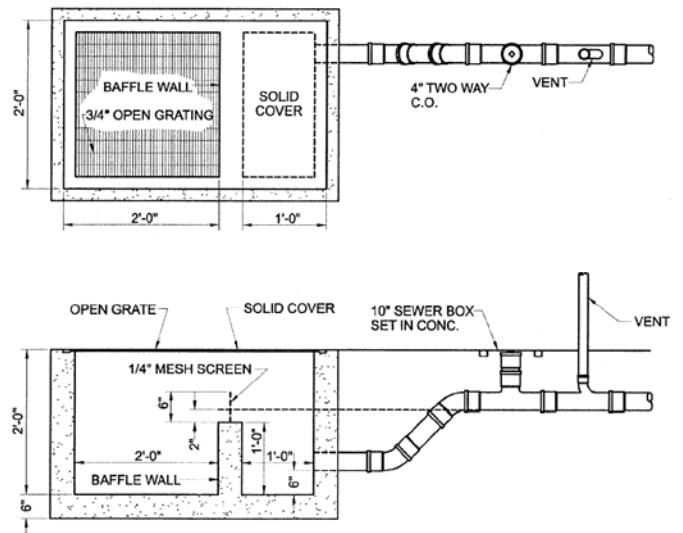


Figure 1005.N.8—Sand Interceptor

9. Laundry Traps. Laundry equipment that does not have integral strainers shall discharge into an interceptor having a wire basket or similar device that is removable for cleaning and that will prevent passage into the drainage system of solids 1/2-inch or larger in maximum dimension, such as string, rags, buttons or other solid materials detrimental to the drainage system. The laundry trap (laundry interceptor/lint trap) and its connection to the drainage system shall conform to the design depicted in

Figure 1005.N.9 of this Part. Any modifications of the design shall be approved by the plumbing official. In additions, the size, location and venting of the interceptor shall be approved by the plumbing official.

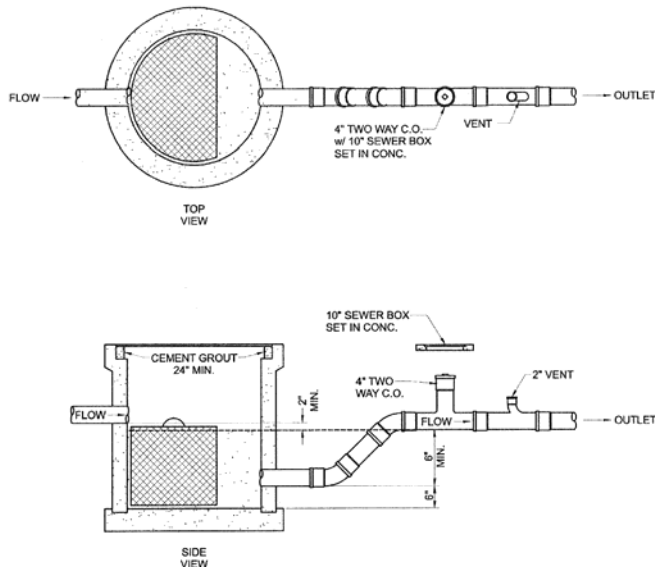


Figure 1005.N.9—Lint Trap (with Non-Corrode Basket)

10. Bottling Separators. Bottling plants shall discharge their process waste water into an interceptor/separator which will provide for the separation of broken glass or other solids before discharging into the drainage system. The design, size, location and venting of the bottling separator shall be approved by the plumbing official.

11. Slaughter House Separators. Slaughtering room drains shall be equipped with separators which shall prevent the discharge into the drainage system of feathers, entrails and other materials likely to clog the drainage system. The design, size, location and venting of the slaughter house separator shall be approved by the plumbing official.

#### 12. Special Type Separators

a. Every fish, fowl and animal slaughter house or establishment and every fish, fowl and meat packing or curing establishment and every soap factory, tallow rendering, fat rendering and hide curing establishment, or any other establishment from which considerable amounts of grease are likely to be discharged into any plumbing system, community sewerage system, commercial treatment facility, or individual sewerage system, shall be connected to and shall drain or discharge into a grease trap meeting the requirements of this Section and approved by the plumbing official for this use.

b. Interceptors or separators for other special type applications shall not be installed until their design, size, location and venting have been approved by the plumbing official.

AUTHORITY NOTE: Promulgated in accordance with R.S. 40:4(A)(7) and R.S. 40:5(2)(3)(7)(9)(16)(17)(20).

HISTORICAL NOTE: Promulgated by the Department of Health and Hospitals, Office of Public Health, LR 38:2869 (November 2012).

## Chapter 11. Storm Drainage

### §1101. General

A. Scope. The provisions of this Chapter shall govern the materials, design, construction, and installation of storm drainage.

B. Drainage Required. Roofs, paved areas, yards, courts and courtyards shall be drained into a storm sewer system.

1. Exception. Dumpster pad drains shall connect to the sanitary sewerage system in accordance with LAC 51:XXIII.3307.

C. Prohibited Drainage. Storm water shall not be drained into sewers intended for sewage only.

D. Expansion Joints. Expansion joints or sleeves shall be provided where warranted by temperature variations or physical conditions.

E. Subsoil Drains. Where subsoil drains are placed under the cellar or basement floor or are used to surround the outer walls of a building, they shall be made of open-jointed or horizontally split or perforated clay tile, asbestos cement pipe, or plastic pipe meeting the requirements of Table 703 of this code, not less than 4-inch diameter. When the building is subject to backwater, the subsoil drain shall be protected by an accessibly located backwater valve. Subsoil drains may discharge into a properly trapped area drain or sump. Such sumps do not require vents.

F. Building Subdrains. Building subdrains located below the building storm sewer level shall discharge into a sump or receiving tank, the contents of which shall be automatically lifted and discharged into the building gravity drainage system as required for building sumps.

G. Pumping System. Pumping systems installed to remove contents of collecting sumps shall include the sump pump, pit, and discharge piping as defined below.

1. Sump Pump. An automatic water pump for the removal of drainage from a sump, pit, or low point in a residential, commercial, or industrial property shall be of a capacity and head appropriate to anticipated use requirements.

2. Sump Pit. The sump pit size shall be not less than 18-inch (457 mm) diameter and may be constructed of tile, steel, plastic, cast iron, concrete, or other material accepted by the plumbing official, topped by a removable cover adequate to support anticipated loads in area of use. The pump floor shall provide permanent support for the pump.

3. Electrical service outlets, when required, shall meet the requirements of NFPA 70 or local codes.

4. Discharge piping shall meet the requirements of §1103.A, §1103.B, §1103.C or §1103.D of this code and shall include a gate valve and a full flow check valve. Size

and fittings shall be the same size as, or larger than, pump discharge tapping.

H. Backwater Devices. The installation of backwater devices as protection for fixtures subject to backflow shall be in accordance with requirements of this Part.

I. Tests. The interior leaders and downspouts system shall be tested in accordance with §319.E of this code.

AUTHORITY NOTE: Promulgated in accordance with R.S. 40:4(A)(7) and R.S. 40:5(2)(3)(7)(9)(16)(17)(20).

HISTORICAL NOTE: Promulgated by the Department of Health and Hospitals, Office of Public Health, LR 38:2878 (November 2012).

**§1103. Materials**

A. Inside Conductors Including Above Ground Storm Drains. Conductors placed within buildings or run in vent or pipe shafts shall be aluminum, cast iron, galvanized steel, galvanized ferrous alloys, brass, copper tubing of a weight not less than that of copper drainage tube Type DWV, copper pipe or Schedule 40 plastic pipe.

B. Building Storm Drains. All building storm drains shall be of materials required for building drains in §§703.C and 703.D of this code.

C. Underground Building Storm Drains. Underground building storm drains, inside the building perimeter, shall be of cast iron soil pipe, ferrous-alloy piping, copper tube Type DWV, or Schedule 40 plastic piping.

D. Building Storm Sewers. The building storm sewer shall be of cast iron soil pipe, vitrified-clay pipe, concrete pipe, or plastic pipe meeting the requirements of Table 703 of this code.

AUTHORITY NOTE: Promulgated in accordance with R.S. 40:4(A)(7) and R.S. 40:5(2)(3)(7)(9)(16)(17)(20).

HISTORICAL NOTE: Promulgated by the Department of Health and Hospitals, Office of Public Health, LR 38:2878 (November 2012).

**§1105. Specifications**

A. Pipe, tubing, and fittings for storm drainage systems shall conform to the standards listed in Table 703 of this code.

AUTHORITY NOTE: Promulgated in accordance with R.S. 40:4(A)(7) and R.S. 40:5(2)(3)(7)(9)(16)(17)(20).

HISTORICAL NOTE: Promulgated by the Department of Health and Hospitals, Office of Public Health, LR 38:2878 (November 2012).

**§1107. Conductors and Connections**

A. Protection. Rain water conductors installed along alleyways, driveways, or other locations where they may be exposed to damage shall be protected.

B. Separation of Storm Drainage from Sanitary Sewers. The sanitary sewer and storm drainage systems of a building shall be entirely separate.

C. Floor Drains. Floor drains shall not be connected to a storm drain.

AUTHORITY NOTE: Promulgated in accordance with R.S. 40:4(A)(7) and R.S. 40:5(2)(3)(7)(9)(16)(17)(20).

HISTORICAL NOTE: Promulgated by the Department of Health and Hospitals, Office of Public Health, LR 38:2878 (November 2012).

**§1109. Roof Drains**

A. Material. Roof drains shall be of an approved corrosion resistant material with adequate strainer area and shall comply with the applicable standards in Table 303 of this code.

B. Strainers. When roof drains are provided they shall have strainers extending not less than 4 inches (102 mm) above the surface of the roof immediately adjacent to the roof drain. Strainers shall have an available inlet area, above roof level, of not less than one and a half times the area of the conductor or leader to which the drain is connected.

C. Flat Decks. Roof drain strainers for use on sun decks, parking decks, and similar areas, normally serviced and maintained, may be of the flat surface type, level with the deck and shall have an available inlet area not less than two times the area of the conductor or leader to which the drain is connected.

D. Roof Drain Flashings. The connection between roofs and roof drains which pass through the roof and into the interior of the building shall be made watertight by the use of proper flashing material.

AUTHORITY NOTE: Promulgated in accordance with R.S. 40:4(A)(7) and R.S. 40:5(2)(3)(7)(9)(16)(17)(20).

HISTORICAL NOTE: Promulgated by the Department of Health and Hospitals, Office of Public Health, LR 38:2878 (November 2012).

**§1111. Size of Leaders and Storm Drains**

A. Vertical Leaders. Vertical leaders shall be sized for the maximum projected roof area, according to Table 1111.A of this code below. If a vertical offset is 45 degrees or less, the leader can be sized as a vertical pipe. If the offset is greater than 45 degrees, the pipe must be sized as a horizontal pipe.

Size of Leader or Conductor (in)	Maximum Projected Roof Area (sq ft)
2	720
2 1/2	1300
3	2200
4	4600
5	8650
6	13,500
8	29,000

NOTE:

1. The equivalent diameter of square or rectangular leader may be taken as the diameter of that circle which may be inscribed within the cross-sectional area of the leader. See also §1111.B.2 of this code.

B. Building Storm Drains. Building storm drains shall comply with the following.

1. The size of the building storm drain or any of its horizontal branches having a slope of 1/2-inch or less per

foot (41.6 mm/m) shall be based upon the maximum projected roof area to be handled according to Table 1111.B of this code below.

Table 1111.B Size of Horizontal Storm Drains			
Diameter of Drain (in)	Maximum Projected Roof Area for Drains of Various Slopes (sq ft)		
	1/8 in Slope	1/4 in Slope	1/2 in Slope
3	822	1,160	1,644
4	1,880	2,650	3,760
5	3,340	4,720	6,680
6	5,350	7,550	10,700
8	11,500	16,300	23,000
10	20,700	29,200	41,400
12	33,300	47,000	66,600
15	59,500	84,000	119,000

2. Tables 1111.A and 1111.B of this code above are based upon a rate of rainfall of 4 inches (102 mm) per hour. If in any state, city or other political subdivision, the maximum rate of rainfall is more or less than 4 inches (102 mm) per hour, then the figures for roof area shall be adjusted proportionately by dividing the figure by four and multiplying by the maximum rate of rainfall in inches (mm) per hour. See §1111.E of this code.

C. Blockage Avoidance. To avoid stoppages, building drainage piping cannot be reduced in size in the direction of flow throughout its length. i.e., an 8-inch (203-mm) horizontal building storm drain must tie to an 8-inch (203-mm) vertical leader, even if Table 1111.A of this code allows for a smaller size for the vertical leader.

D. Vertical Walls. In sizing roof drains and storm drainage piping, one-half (1/2) of the area of any vertical wall which diverts rain water to the roof shall be added to the projected roof area for inclusion in calculating the required size of vertical leaders and horizontal storm drainage piping.

E. Maximum Rates of Rainfall. Primary roof drain systems shall be designed using Tables 1111.A and 1111.B of this code and adjusted in accordance with §1111.B.2 of this code for the local rainfall for a 60 minute duration and a 100-year return period in Figure 1111.E of this Part. The plumbing official may approve local weather data on the maximum rate of rainfall when available.

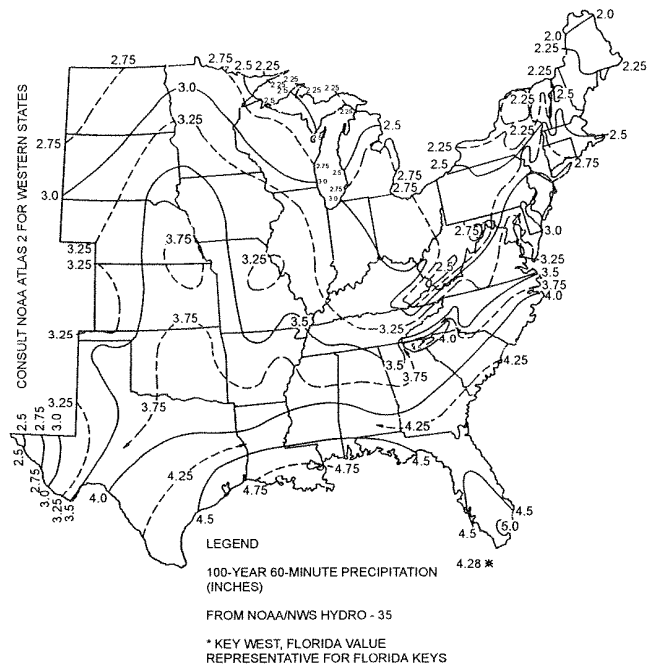


Figure 1111.E—Rainfall Rate for Primary Roof Drains (in./hr.)

F. Parapet Wall Scupper Location. The location of parapet wall roof drainage scuppers and overflow scuppers shall be such that discharge can cause no personal injury or property damage. When neither conductor heads nor gutters are used to catch the water, scupper spouts shall extend past the exterior surface of the building to avoid wetting the building surface.

AUTHORITY NOTE: Promulgated in accordance with R.S. 40:4(A)(7) and R.S. 40:5(2)(3)(7)(9)(16)(17)(20).

HISTORICAL NOTE: Promulgated by the Department of Health and Hospitals, Office of Public Health, LR 38:2879 (November 2012).

**§1113. Secondary (Emergency) Roof Drains**

A. Secondary Drainage Required. Secondary (emergency) roof drains or scuppers shall be provided where the roof perimeter construction extends above the roof in such a manner that water would be entrapped should the primary drains allow buildup for any reason.

B. Separate Systems Required. Secondary roof drain systems shall have piping and point of discharge separate from the primary system. Discharge shall be above grade<sub>(G)</sub> in a location which would normally be observed by the building occupants or maintenance personnel.

C. Maximum Rainfall Rate for Secondary Drains. Secondary (emergency) roof drain systems or scuppers shall be sized based on the flow rate caused by the 100-year 15 minute precipitation as indicated in Figure 1113.C of this Part. The flow through the primary system shall not be considered when sizing the secondary roof drain system.

## Chapter 12. Alternate Designed Plumbing Systems

### §1201. General

A. Approval of alternate designed plumbing systems will be considered on an individual basis.

AUTHORITY NOTE: Promulgated in accordance with R.S. 40:4(A)(7) and R.S. 40:5(2)(3)(7)(9)(16)(17)(20).

HISTORICAL NOTE: Promulgated by the Department of Health and Hospitals, Office of Public Health, LR 38:2880 (November 2012).

### §1203. Requirements for Approval

A. Plans and Specifications. Plans and specifications for any proposed alternate designed plumbing system shall be submitted to the state health officer for review and approval prior to construction. Such plans and specifications shall be appropriately sealed and signed by a Louisiana Registered Professional Engineer registered in either civil or mechanical engineering.

B. Responsibility of Professional Engineer. The Professional Engineer referenced in §1203.A of this code shall be responsible for:

1. certifying the system design;
2. inspecting the system during installation;
3. certifying that the installed system is in compliance with the approved design specifications;
4. supervising any test(s) performed on the system; and,
5. certifying the results of any required testing.

C. Owner's Notice. Any permits issued for an alternate designed plumbing system shall be issued only after the owner of the building has assured the state health officer in writing that he is aware of the third party notification requirements of §1207 of this code. In addition, any permits issued for work requiring a performance test shall be issued only after the owner of the building has assured the state health officer in writing that he is also aware of the testing requirements of §1205 of this code.

AUTHORITY NOTE: Promulgated in accordance with R.S. 40:4(A)(7) and R.S. 40:5(2)(3)(7)(9)(16)(17)(20).

HISTORICAL NOTE: Promulgated by the Department of Health and Hospitals, Office of Public Health, LR 38:2880 (November 2012).

### §1205. Tests

A. General Testing Requirements. The state health officer and/or the local plumbing official may also require tests to be conducted prior to occupancy to assure that the proposed design is satisfactory and complies with the intent of this code. Such tests shall be made in accordance with approved standards, but in the absence of such standards, the state health officer and/or the local plumbing official shall specify the test procedure(s). In general, such tests shall indicate that all fixtures properly discharge when flushed simultaneously with not less than 1-inch (25.4mm) of water

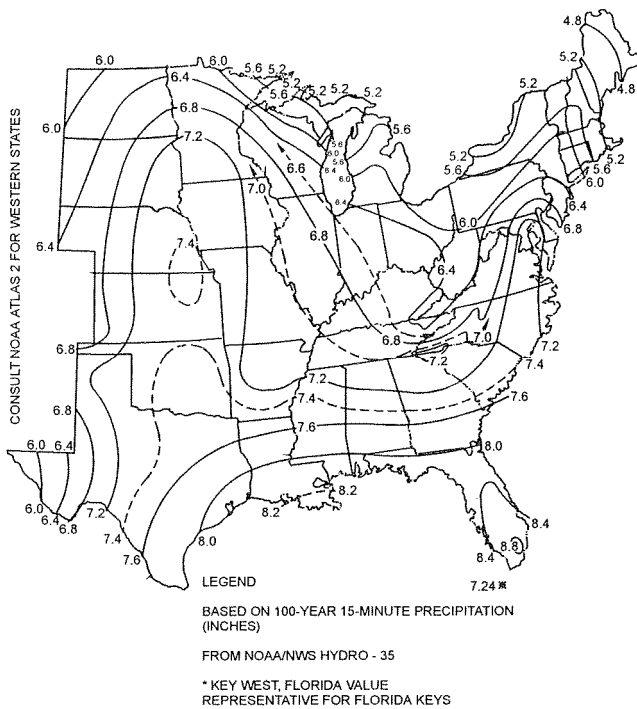


Figure 1113.C—Rainfall Rate for Primary Roof Drains (in./hr.)

AUTHORITY NOTE: Promulgated in accordance with R.S. 40:4(A)(7) and R.S. 40:5(2)(3)(7)(9)(16)(17)(20).

HISTORICAL NOTE: Promulgated by the Department of Health and Hospitals, Office of Public Health, LR 38:2879 (November 2012).

### §1115. Values for Continuous Flow

A. Where there is a continuous or semicontinuous discharge into the building storm drain or building storm sewer, as from a pump, ejector, air conditioning plant, or similar device, each gallon per minute of such discharge shall be computed as being equivalent to 24 sq ft (2.23 m<sup>2</sup>) of roof area, based upon a 4-inch (102 mm) rainfall.

AUTHORITY NOTE: Promulgated in accordance with R.S. 40:4(A)(7) and R.S. 40:5(2)(3)(7)(9)(16)(17)(20).

HISTORICAL NOTE: Promulgated by the Department of Health and Hospitals, Office of Public Health, LR 38:2880 (November 2012).

### §1117. Additional Information for Storm Drainage

A. Additional information for storm drainage is contained in Chapter 18 (Appendices) of this code, §1803 (Appendix A - Roof Drain Sizing Method). Such additional information in Chapter 18 shall not be construed as superceding any pertinent regulation(s) contained in Chapters 1-17 of this code.

AUTHORITY NOTE: Promulgated in accordance with R.S. 40:4(A)(7) and R.S. 40:5(2)(3)(7)(9)(16)(17)(20).

HISTORICAL NOTE: Promulgated by the Department of Health and Hospitals, Office of Public Health, LR 38:2880 (November 2012).



seal left in the trap after testing and that there is no evidence of sewer gas passing through the trap seal.

B. Roughing-In. The roughing-in test shall be as provided for in other Chapters of this code.

C. Tests and Inspection of the Single Stack Discharge and Ventilating Pipe System or any other Single Stack Plumbing System. When a single stack discharge and ventilating pipe system (a specific type of alternate designed plumbing system) or any other single stack plumbing system has been approved by the state health officer under the requirements of this Chapter, the following tests/inspections shall be performed.

1. Performance Test Required. In any building in which fixtures or appliances, other than those specifically provided for in Table 1811.D.5.5A of this code, are to be installed or in existing buildings in which the single stack discharge and ventilating pipe system or any other single stack plumbing system exists and additional fixtures are to be added, the plumbing official shall require and supervise a performance test as hereafter provided.

2. Application and Restrictions. When required in new construction, the system shall successfully pass the test before the building is permitted to be occupied. In existing buildings where piping is added for additional fixtures or appliances, such new piping shall not be placed in service until the performance test is approved. Should the system fail to pass the test, the new construction shall be modified as the plumbing official may direct, or the system shall be reconstructed to meet the requirements of other Chapters of this code, or the added fixtures and appliances shall be removed and all waste and vent pipes permanently closed so as to form no dead ends and all wall and other openings shall be put back in their original or finished condition.

a. Exception. Central washing facilities connected separately to the building drain or sewer in an installation that is otherwise constructed in accordance with other Chapters of this code are exempt from the performance testing prescribed by this Section.

3. Performance Test. Every trap shall retain not less than 1-inch (25.4 mm) of seal when subjected to the appropriate discharge tests given below. These tests are designed to simulate the probable worst conditions in practice. Each test should be repeated three times, the trap being recharged before each test, and the maximum loss of seal in any one test, measured by a dip stick, shall be taken as the significant result. The number of fixtures to be discharged simultaneously when investigating the effect of the flow of water down the stack depends on the number of fixtures and on the frequency with which they are used. The number of fixtures to be discharged simultaneously is given in Table 1811.D.11 of this code.

4. Test for Self-Siphonage. To test for the effect of self-siphonage, the waste fixture shall be filled to overflowing level and discharged in the normal way. The seal remaining in the trap shall be measured when the discharge has finished. This test is most important for wash

basins, but it is not applicable for water closets which shall be flushed in the normal manner.

AUTHORITY NOTE: Promulgated in accordance with R.S. 40:4(A)(7) and R.S. 40:5(2)(3)(7)(9)(16)(17)(20).

HISTORICAL NOTE: Promulgated by the Department of Health and Hospitals, Office of Public Health, LR 38:2880 (November 2012).

### **§1207. Third Party Notification**

A. After installation of any alternate designed plumbing system, the owner shall notify third parties of its existence by having a document recorded in the Clerk of Court's conveyance records in the parish in which such alternate designed plumbing system has been installed. The document so recorded shall reference a prior conveyance record (COB/folio) of the parcel of ground upon which the alternate designed plumbing system is located (e.g., the conveyance recording a previous Act of Sale of the parcel of ground). The document will state that the plumbing of the building located on this particular parcel of ground contains an "alternate designed plumbing system" which cannot be modified in any manner by future owners/lessees without first obtaining an approval of such proposed modifications from the state health officer in accord with the requirements of Chapter 12 (Alternate Designed Plumbing Systems) of this code. Proof of recordation shall be provided to the state health officer and the local plumbing official prior to issuance of a building occupancy permit.

AUTHORITY NOTE: Promulgated in accordance with R.S. 40:4(A)(7) and R.S. 40:5(2)(3)(7)(9)(16)(17)(20).

HISTORICAL NOTE: Promulgated by the Department of Health and Hospitals, Office of Public Health, LR 38:2881 (November 2012).

## **Chapter 13. Medical Facilities Plumbing Systems [formerly Appendix G - Medical Facilities Plumbing Systems]**

### **§1301. General**

A. Scope. The following Subparagraphs provide the scope of this Chapter.

1. The provisions of this Chapter are intended to set out those items of hospital/medical facilities plumbing systems which differ from plumbing systems in other buildings. Special care shall be accorded the hospital plumbing system because of its direct relationship to adequate medical care and the need for added protection for patients and hospital personnel from health hazards.

2. It is understood that hospital/medical facilities plumbing systems shall conform not only to the requirements of this Chapter, but also to the requirements contained in the other Chapters of this code.

3. The provisions of this Chapter shall apply to plumbing installations in clinics, doctors' offices, nursing homes, and other medical facilities, etc., as well as in hospital installations.

B. Definitions. The following words and terms shall, for the purposes of this Chapter and as stated elsewhere in this code, have the meanings shown herein. Refer to Chapter 2 of this code for general definitions.

*Aspirator*—a fitting or device supplied with water or other fluid under positive pressure which passes through an integral orifice or constriction causing a vacuum. (*Aspirators* are often referred to as suction apparatus, and are similar in operation to an ejector.)

*Autoclave*—see *sterilizer, pressure*.

*Autopsy Table*—a *fixture* or table used for post-mortem examination of a body.

*Bedpan Hopper*—see *clinical sink*.

*Bedpan Steamer* or *Bedpan Boiler*—a *fixture* used for scalding bedpans or urinals by direct application of steam or boiling water.

*Bedpan Washer and Sterilizer*—a *fixture* designed to wash bedpans and to flush the contents into the *sanitary drainage system*. It may also provide for emptying, cleaning, and sometimes for steaming bedpans, and for no other purpose.

*Bedpan Washer Hose*—a device supplied with hot and cold water and located adjacent to a water closet or *clinical sink* to be used for cleansing bedpans.

*Clean Utility Room*—a workroom, normally located near the nurses' station, designed and equipped to facilitate the heating and refrigeration of food items, placement of an ice machine, and/or the preparation, cleaning and incidental sterilization of the various supplies, instruments, utensils, etc., involved in nursing treatment and care.

*Clinical Sink*—a *fixture* meeting the design requirements of §1303.B of this code for the rinsing of bedpans and soiled linen. Such fixtures shall have a *trap* size of not less than 3 inches.

*Effective Opening*—the minimum cross-sectional area of the *water outlet* at the point of water supply discharge or the minimum cross-sectional area of the *liquid waste outlet* at the point of *indirect waste pipe* discharge, measured or expressed in terms of:

- a. diameter of a circle; or,
- b. if the outlet is not circular, the diameter of a circle of equivalent cross-sectional area.

[This term is applicable to and mainly used when determining the minimum unobstructed vertical distance through the free atmosphere {*air gap (water distribution)*} required between the *water outlet* and the *flood rim level* of the *fixture* or receptacle into which it is discharging. This term may also be applicable when determining the minimum unobstructed vertical distance through the free atmosphere {*air gap (drainage system)*} required between a *liquid waste outlet* of an *indirect waste pipe* and the *flood rim level* of the *indirect waste receptor*.]

*Medical Facilities*—hospitals, ambulatory surgical centers, renal dialysis centers, nursing homes, doctor's offices, clinics, and similar facilities providing medical care.

*Nurses' Station*—an area in the nursing unit separated from the corridor by counter or desk, designed to permit nurses to record and file each patient's history and progress, observation and control of corridor, preparation of medicines and maintain contact with patients, the hospital and the outside by local and public means of communication.

*Scrub Sink*—a device usually located in the operating suite to enable operating personnel to scrub their hands prior to the operating procedure. The hot and cold water supply is activated by a knee-action mixing valve or by wrist or pedal control

*Soiled Utility Room*—a small workroom, normally located near the nurses' station, which is designed and equipped for emptying, cleaning, and sometimes for steaming bedpans and patient urinals, and for no other purpose.

*Sterilizer, Boiling Type*—a device or *fixture* of the non-pressure design which is used for boiling instruments, utensils, and other equipment in order to disinfect them. Some devices are portable and others are connected to the *plumbing system*.

*Sterilizer, Instrument*—a device for the sterilization of various instruments.

*Sterilizer, Pressure*—a device or *fixture* of the pressure vessel design which uses steam under pressure for sterilizing. Also called an *autoclave*.

*Sterilizer, Pressure Instrument Washer Sterilizer*—a device or *fixture* of the pressure vessel design which both washes and sterilizes instruments during the operating cycle of the device or *fixture*.

*Sterilizer, Utensil*—a device or *fixture* for the sterilization of utensils used in hospital services.

*Sterilizer Vent*—a separate pipe or *stack*, indirectly connected to the building *drainage system* at the lower terminal, which receives the vapors from non-pressure sterilizers, or the exhaust vapors from *pressure sterilizers*, and conducts the vapors directly to the outer air. Sometimes called vapor, steam, atmospheric, or exhaust vent.

*Sterilizer, Water*—a device for sterilizing water and storing sterile water.

*Still*—a device used in distilling liquids.

AUTHORITY NOTE: Promulgated in accordance with R.S. 40:4(A)(7) and R.S. 40:5(2)(3)(7)(9)(16)(17)(20).

HISTORICAL NOTE: Promulgated by the Department of Health and Hospitals, Office of Public Health, LR 38:2881 (November 2012).

### §1303. Fixtures

A. Bedpans. Acceptable flush rim bedpan hoppers (clinical sink), bedpan washers, and/or other acceptable fixtures and equipment shall be provided for the disposing of bedpan contents and the cleansing and disinfection of bedpans in soiled utility rooms.

B. Clinical Sink. A clinical sink shall have an integral trap in which the upper portion of a visible trap seal provides a water surface. The fixture shall be so designed as to permit complete removal of the contents by siphonic or blowout action, or both, and to reseal the trap. A flushing rim shall provide water to cleanse the interior surface. The fixture shall have flushing and cleansing characteristics similar to a water closet.

C. Prohibited Use of Clinical and Service Sinks. A clinical sink serving a soiled utility room shall not be considered as a substitute for, nor shall it be used as, a janitor's service sink. A janitor's service sink shall not be used for the disposal of urine, fecal matter, or other human waste.

D. Ice Prohibited in Soiled Utility Room. Machines for manufacturing ice, or any device for the handling or storage of ice, shall not be located in a soiled utility room. Machines for manufacturing ice, or devices for handling or storage of ice intended for either human consumption or packs, may be located in a clean utility room, floor pantry, or diet kitchen.

E. Sterilizer Equipment Requirements. The following apply to sterilizer equipment.

1. It shall be unlawful to de-scale or otherwise submit the interior of water sterilizers, stills, or similar equipment to acid or other chemical solutions while the equipment is connected to the water or drainage system.

2. New pressure sterilizers and pressure instrument washer-sterilizers hereafter installed shall display, in a location clearly visible at all times, the ASME Standard symbol and data plate.

3. All sterilizer piping and devices necessary for the operation of sterilizers shall be accessible for inspection and maintenance, and shall satisfy the following.

a. Steam supplies to sterilizers, including those connected by pipes from overhead mains or branches, shall be drained to prevent any excess moisture from reaching the sterilizer. The condensate drainage from the steam supply shall be discharged by gravity.

b. Steam condensate return from sterilizers shall not be connected to pressure or vacuum return systems; only gravity returns shall be acceptable. Steam condensate returns from sterilizers shall not be connected to overhead mains or branches.

c. Pressure sterilizers should be equipped with an acceptable means of condensing and cooling the exhaust steam vapors. Nonpressure sterilizers should be equipped with an acceptable device which will automatically control the vapors in a manner so as to confine them within the vessel, or equipped with an acceptable means of condensing and cooling the vapors.

d. Gas fired equipment or apparatus, requiring either water or drainage connections or both, shall meet the standards of the American National Standards Institute.

F. Special Elevations. Control valves, vacuum outlets, and devices which protrude from a wall of an opening, emergency, recovery, examining, or delivery room, or in a corridor or other locations where patients may be transported on a wheeled stretcher, shall be so located at an elevation which will preclude bumping the patient or stretcher against the device. When necessary to install at a low elevation, safety precautions should be taken to protect the personnel.

G. Plumbing in Mental Hospitals. In mental hospitals, special consideration should be given to piping, controls and fittings of plumbing fixtures as required by the types of mental patients being treated. Pipes or traps should not be exposed, and fixtures should be substantially bolted through walls.

H. Handwashing Facilities. Medical facilities, including doctor's offices and clinics, shall be provided with hand washing facilities within each patient examination and treatment room. The hand wash facility shall be provided with hot and cold water delivered via a mixing faucet.

AUTHORITY NOTE: Promulgated in accordance with R.S. 40:4(A)(7) and R.S. 40:5(2)(3)(7)(9)(16)(17)(20).

HISTORICAL NOTE: Promulgated by the Department of Health and Hospitals, Office of Public Health, LR 38:2882 (November 2012).

### **§1305. Drainage and Venting**

A. Ice Storage Chest Drains. Any drain serving an ice storage chest or box shall discharge over an indirect waste receptor separate from all other fixture wastes. Each terminal shall discharge through an air gap (drainage system) above the receptor. The end shall be covered with a removable screen of not less than 10 mesh per square inch (15.5 mesh per 1000 sq mm), and if discharging vertically, the terminal shall be cut at an angle of 45° (0.785 rad).

B. Bedpan Washers and Clinical Sinks. Bedpan washers and clinical sinks shall be connected to the soil pipe system and vented following the requirements as applied to water closets, except that bedpan washers require additional local vents.

C. Sterilizer Wastes. Wastes for sterilizers shall conform with the following.

1. Indirect Wastes Required. All sterilizers shall be provided with individual and separate indirect wastes, with air gaps (drainage system) of not less than two diameters of the waste tailpiece. The upper rim of the receptor, funnel, or basket type waste fitting shall be not less than 2 inches (51 mm) below the vessel or piping, whichever is lower. Except as provided in Paragraphs 2 and 4 below of §1305.C, a "P" trap shall be installed on the discharge side of, and immediately below, the indirect waste connection serving each sterilizer.

2. Recess Room Floor Drain. Floor drains in a room or area where the sterilizer is recessed shall conform with the following.

a. In all recess rooms containing the recessed or concealed portions of sterilizers, not less than one acceptable

floor drain, connecting to the drainage system, shall be installed in a manner to drain the entire floor area.

b. The recess room floor drain waste and trap shall be a minimum 3-inch (76 mm) diameter. It shall receive the drainage from at least one sterilizer within the recess room to assure maintenance of the floor drain trap seal. The sterilizer drain shall be installed on a branch taken off between the floor drain trap and the drain head. An individual waste trap shall not be required on this type of installation.

3. Prohibited Connections. Branch funnel and branch basket type fittings, except as provided in §1305.C.4 of this code below, are prohibited on any new installation or when relocating existing equipment. Existing branch funnel or branch basket type installations shall be provided with an acceptable indirect waste below the branch connections.

4. Battery Assemblies. A battery assembly of not more than three sterilizer wastes may drain to one trap, provided the trap and waste are sized according to the combined fixture unit rating, the trap is located immediately below one of the indirect waste connections, the developed distance of a branch does not exceed 8 feet (2438 mm), and the branches change direction through a tee-wye or wye pattern fitting.

5. Bedpan Steamers, Additional Trap Required. A trap with a minimum seal of 3 inches (76 mm) shall be provided in a bedpan steamer drain located between the fixture and the indirect waste connection.

6. Pressure Sterilizer. Except when an exhaust condenser is used, a pressure sterilizer chamber drain may be connected to the exhaust drip tube before terminating at the indirect waste connection. If a vapor trap is used, it shall be designed and installed to prevent moisture being aspirated into the sterilizer chamber. The jacket steam condensate return, if not connected to a gravity steam condensate return, shall be separately and indirectly wasted. If necessary to cool a high temperature discharge, a cooling receiver, trapped on its discharge side, may serve as the fixture trap.

7. Pressure Sterilizer Exhaust Condensers. The drain from the condenser shall be installed with an indirect waste as prescribed in this Part. If condensers are used on pressure sterilizers, the chamber drain shall have a separate indirect waste connection.

8. Water Sterilizer. All water sterilizer drains, including tank, valve leakage, condenser, filter and cooling, shall be installed with indirect waste and according to §1305.C.2.a of this code.

9. Pressure Instrument Washer-Sterilizer. The pressure instrument washer-sterilizer chamber drain and overflow may be interconnected. Also, they may be interconnected with the condensers. The indirect waste shall follow the provision set forth in this Part.

D. Aspirators. In operating rooms, emergency rooms, recovery rooms, delivery rooms, examining rooms, autopsy rooms, and other locations except laboratories, where

aspirators are installed for removing blood, pus, or other fluids, the discharge from any aspirator shall be indirectly connected to the drainage system. The suction line shall be provided with a bottle or similar trap to protect the water supply.

E. Vacuum System Stations. Vacuum system station locations shall be considered from the standpoint of convenience and practical use. The receptacles should be built into cabinets or recesses but shall be visible and readily accessible.

F. Bottle System. Vacuum (fluid suction) systems intended for collecting, removing or disposing of blood, pus or other fluids by the so-called bottle system shall be provided with receptacles, which are equipped with an overflow preventative device, at each vacuum outlet station. Each vacuum outlet station should be equipped with a secondary safety receptacle as an additional safeguard against fluids, other than air entering the vacuum piping systems.

G. Central Disposal System Equipment. All central vacuum (fluid suction) systems shall assure continuous service. Systems equipped with collecting or control tanks shall provide for draining and cleaning of the tanks while the system is in operation. In hospitals or institutions having emergency power provisions, the system shall be capable of remaining in service during the use of emergency power. The exhausts from a vacuum pump used in connection with a vacuum (fluid suction) system shall discharge separately to the outer atmosphere. The exhaust discharge shall not create a nuisance or hazard within, without, around or about the premises. Termination of the exhaust to the atmosphere shall be the same as required for sanitary sewer vents.

H. Central Vacuum and Disposal Systems. Central vacuum and disposal systems shall conform with the following.

1. The waste from a central vacuum (fluid suction) system of the disposal type which is connected to the drainage system, whether the disposal be by barometric lag, collection tanks, or bottles, shall be directly connected to the sanitary drainage system through a trapped waste.

2. The piping of a central vacuum (fluid suction) system shall be of corrosion resistant material having a smooth interior surface. A branch shall not be less than 1/2-inch for one outlet and sized according to the number of vacuum outlets, and a main shall not be less than 1-inch. The pipe sizing shall be increased according to acceptable engineering practices. All piping shall be provided with adequate and accessible cleanout facilities on mains, and branches, and shall be accessible for inspection, maintenance, and replacements.

I. Condensate Drains for Space Cooling and Heating Systems. The lowest point of a condensate riser or risers shall be trapped and discharged over an indirect waste sink. The trap may be either a "P" or a "running trap" with a cleanout. A branch shall be installed upstream from the condensate drain trap for flushing and resealing purposes.

The condensate drain and trap shall be located above the lowest floor level of the building.

J. Vent Material. Material for local vents serving bedpan washers and sterilizer vents serving sterilizers shall be sufficiently rust proof, erosion and corrosion resistant to withstand intermittent wetting and drying from steam vapors, to withstand the distilled water solvent action of the steam vapors and to withstand frequent and immediate changes of temperatures.

K. Vent Connections Prohibited. Connections between local vents serving bedpan washers, sterilizer vents serving sterilizing apparatus and normal sanitary plumbing systems are prohibited. Furthermore, only one type of apparatus shall be served by a given local vent.

L. Local Vents and Stacks. Local vents and stacks shall comply with the following.

1. Bedpan washers shall be vented to the outer atmosphere by means of one or more local vents. Termination of the vent to the atmosphere shall be the same as required for sanitary sewer vents. The local vent for a bedpan washer shall not be less than a 2-inch diameter pipe. A local vent serving a single bedpan washer may drain to the fixture served.

2. Where bedpan washers are located above each other on more than one floor, a local vent stack may be installed to receive the local vent on the various floors. More than three bedpan washers shall not be connected to a 2-inch local vent stack, six to a 3-inch local vent stack, and 12 to a 4-inch local vent stack. In multiple installations, the connections between a bedpan washer local vent and a local vent stack shall be made by use of the tee or tee-wye sanitary pattern drainage fittings, installed in an upright position.

3. The bottom of the local vent stack, except when serving only one bedpan washer, shall be drained by means of a trapped and vented waste connection to the plumbing sanitary drainage system. The trap and waste shall be the same as the local vent stack.

4. A water supply of not less than 1/4-inch minimum tubing shall be taken from the flush supply of each bedpan washer on the discharge or fixture side of the vacuum breaker (taken off at least 4 inches below the critical level of the vacuum breaker), trapped to form not less than a 3-inch (76 mm) seal, and connected to the local vent stack on each floor. The water supply shall be so installed as to provide a supply of water to the local vent stack for cleansing and drain trap seal maintenance each time a bedpan washer is flushed.

M. Sterilizer Vents and Stacks. Sterilizer vents and stacks shall comply with the following.

1. Multiple installations of pressure and nonpressure sterilizers shall have their vent connections to the sterilizer vent stack made by means of inverted wye fittings. Such vent connections shall be accessible for inspection and maintenance.

2. The connection between sterilizer vent or exhaust openings and the sterilizer vent stack shall be designed and installed to drain to the funnel or basket type waste fitting. In multiple installations, the sterilizer vent stack shall be drained separately to the lowest sterilizer funnel or basket type waste fitting or receptor.

N. Sterilizer Vent Stack Sizes. Sterilizer vent stack sizing shall comply with the following.

1. The minimum diameter of a sterilizer vent serving a bedpan steamer shall be 1 1/2 inches. Multiple installations shall be sized according to Table 1305.N.1 of this code below.

2. The minimum diameter of a sterilizer vent stack shall be 2 inches when serving a utensil sterilizer, and 1 1/2 inches when serving an instrument sterilizer. Combinations of boiling type sterilizer vent connections shall be based on Table 1305.N.1 of this code below.

3. Sterilizer vent stacks shall be 2 1/2 inches minimum. Those serving combinations of pressure sterilizer exhaust connections shall be sized according to Table 1305.N.2 of this code below.

4. The minimum diameter of a sterilizer vent stack serving an instrument washer-sterilizer shall be 2-inch diameter. Not more than two sterilizers shall be installed on a 2-inch stack, and not more than four on a 3-inch stack.

Table 1305.N.1 Stack Sizes for Bedpan Steamers and Boiling Type Sterilizers (in) (Number of connections of various sizes permitted to various sized sterilizer vent stacks)			
Stack Size (in)	Connection Size (in)		
	1 1/2		2
1 1/2 (see note 1)	1	or	0
2	2	or	1
2 (see note 2)	1	and	1
3 (see note 1)	4	or	2
3 (see note 2)	2	and	2
4 (see note 1)	8	or	4
4 (see note 2)	4	and	4

NOTES:

1. Total of each size.
2. Combination of sizes.

Table 1305.N.2 Stack Sizes for Pressure Sterilizers (in) (Number of connections of various sizes permitted to various sized vent stacks)				
Stack Size (in)	Connection Size (in)			
	3/4	1	1 1/4	1 1/2
1 1/2 (Note 1)	3 or	2 or	1 or	1
1 1/2 (Note 2)	2 and	1		
2 (Note 1)	6 or	3 or	2 or	1
2 (Note 2)	3 and	2		
2 (Note 2)	2 and	1 and	1	
2 (Note 2)	1 and	1 and	1	
3 (Note 1)	15 or	7 or	5 or	3
3 (Note 2)		1 and	2 and	2
	1 and	5 and		1

NOTES:

1. Total of each size.
2. Combination of sizes.

O. Radioactive Materials. All radioactive materials shall be disposed of in a manner so as not to create a hazard to operation and maintenance personnel of the institution or to the public. Specific permission shall be secured from the proper authority to dispose of any radioactive material to the drainage system.

AUTHORITY NOTE: Promulgated in accordance with R.S. 40:4(A)(7) and R.S. 40:5(2)(3)(7)(9)(16)(17)(20).

HISTORICAL NOTE: Promulgated by the Department of Health and Hospitals, Office of Public Health, LR 38:2883 (November 2012).

**§1307. Water Supply**

A. Water Service. All hospitals should have dual services installed in a manner to provide an uninterrupted supply of water in case of a water main break, etc.

B. Hot Water Distribution System. Hot water circulating mains and risers should be run from the hot water storage tank to a point directly below the highest fixture at the end of each branch main. Where the building is higher than three stories, each riser shall be circulated. Each main, branch main, riser and branch to a group of fixtures of the water system shall be valved.

C. Vacuum Breaker Installations. The following shall be considered concerning the installation and use of vacuum breakers.

1. For ordinary hose connections, the maximum height at which any hose is to be used shall be treated as its flood level.

2. Where low volume flows might cause leaking or spitting at the vacuum breaker parts, back pressure may be developed by installing an acceptable minimum orifice valve on the discharge side of the vacuum breaker. This shall be in addition to the regular control valve. This type of installation shall be subject to review and acceptance by the plumbing official before installation.

D. Prohibited Water Closet and Clinical Sink Supply. Jet or water supplied orifices, except those supplied by the flush connections, shall not be located in or connected with a water closet bowl or clinical sink. This Subsection shall not prohibit an acceptable bidet installation.

E. Special Equipment, Water Supply Protection. Table 1307.E of this code sets forth the requirements which shall be followed in protecting the water supply for hospital fixtures against backflow or backsiphonage.

F. Clinical, Hydrotherapeutic and Radiological Equipment. All clinical, hydrotherapeutic, radiological, or any equipment, whether mentioned or not, which is water supplied or discharges to the waste system, shall meet the requirements of this Section and other Sections of this Part covering cross connectors, air gaps, vacuum breakers, and check valves. Special equipment and devices found under these classes include those listed in Table 1307.F of this code.

Fixtures	Type of protection <sup>1</sup>	Remarks
<b>Aspirators:</b>		
Laboratory	Vacuum breaker	
Portable	Vacuum breaker	
Vacuum system	Vacuum breaker	
<b>Bedpan:</b>		
Washers	Vacuum breaker	
Washer hose	Vacuum breaker	Locate 5 ft above floor.
<b>Boiling type sterilizer</b>	Air gap	Not less than twice the effective opening of the water supply.
<b>Exhaust condenser</b>	Vacuum breaker	
<b>Flush floor drain</b>	Vacuum breaker	Locate 6 ft above floor.
<b>Hose connection</b>	Vacuum breaker	
<b>Pressure instrument:</b>		
Washer-sterilizer	Vacuum breaker	
<b>Pressure sterilizer</b>	Vacuum breaker	
<b>Vacuum systems:</b>		
Cleaning	Air gap or vacuum breaker	
Fluid suction	Air gap or vacuum breaker	

NOTE:

1. Where atmospheric vacuum breakers are used, they shall be installed after the last control valve.

G. Condensate Drain Trap Seal. A water supply shall be provided for cleaning, flushing, and resealing the condensate trap. The source of the water supply shall be a refrigerator condenser discharge, a drinking fountain waste, or other acceptable method of flushing and resealing the trap. The water supply shall be not less than 1/2-inch diameter pipe and shall discharge through an air gap not less than twice the diameter of the supply pipe.

H. Valve Leakage Diverter. Each water sterilizer which may be filled with water through directly connected piping shall be equipped with an acceptable leakage diverter and/or bleed-line on the water supply control valve to indicate and conduct any leakage of unsterile water away from the sterile zone.

Clinical	Hydrotherapeutic	Radiological	Other
Dental cuspidors	Control units	Diagnostic x-ray	Violet ray
Surgical cuspidors	Arm bath	Therapy x-ray	Photographic
Dental (flush rim)	Leg bath	X-ray transformers	developing
lavatories	Tub bath	X-ray oil tank	Film
Sitz bath	Immersion bath	Diffraction	developing
Emergency bath	Shower bath	X-ray developing	Microscopic
Receiving bath	Needle bath		
Prenatal bath	Tank		
Infant bath	Pool		
Prophylaxis	Hose		
Shampoo	Syringe douche		
Massage			

AUTHORITY NOTE: Promulgated in accordance with R.S. 40:4(A)(7) and R.S. 40:5(2)(3)(7)(9)(16)(17)(20).

**Table 1307.E  
Fixtures and Their Water Supply Protection**

HISTORICAL NOTE: Promulgated by the Department of Health and Hospitals, Office of Public Health, LR 38:2885 (November 2012).

**§1309. Medical Gas and Medical Vacuum Systems**

A. Where medical gas and medical vacuum systems are installed, the gas piping, outlets, manifold rooms and storage rooms shall be installed in accordance with all of the requirements of the NFPA 99 by individuals properly licensed by the State Plumbing Board of Louisiana (see LAC 46:LV).

AUTHORITY NOTE: Promulgated in accordance with R.S. 40:4(A)(7) and R.S. 40:5(2)(3)(7)(9)(16)(17)(20).

HISTORICAL NOTE: Promulgated by the Department of Health and Hospitals, Office of Public Health, LR 38:2886 (November 2012).

**Chapter 14. Reference Standards**

**§1401. Scope**

A. This Chapter contains the designations, names and edition of standards referenced in this code listed alpha-numerically and the Section numbers where they are referenced.

AUTHORITY NOTE: Promulgated in accordance with R.S. 40:4(A)(7) and R.S. 40:5(2)(3)(7)(9)(16)(17)(20).

HISTORICAL NOTE: Promulgated by the Department of Health and Hospitals, Office of Public Health, LR 38:2886 (November 2012).

**§1403. Referenced Standards**

A. Products manufactured to those standards which are followed by the word "Listed" are required to be listed regardless of the standards' requirements for listing.

Standard Designation	Section/Table
ANSI A21.4-2008*, Cement-Mortar Lining for Ductile-Iron Pipe and Fittings for Water (same as AWWA C104)	Table 303
ANSI A21.10-2008 (R2012)*, Ductile-Iron and Gray-Iron Fittings (same as AWWA C110)	Table 603
ANSI A21.11-2006*, Rubber Gasket Joints for Ductile-Iron Pressure Pipe and Fittings (same as AWWA C111)	709.G
ANSI A21.51-2009*, Ductile-Iron Pipe, Centrifugally Cast (same as AWWA C151)	Table 603
ANSI A21.53 -2006*, Ductile-Iron Compact Fittings for Water Service (same as AWWA C153)	Table 603
ANSI A117.1-2003*, Standard for Accessible and Usable Buildings and Facilities	415.I.1, 415.I.3
ANSI A118.10-2008, Load Bearing, Bonded, Waterproof Membranes for Thin-Set Ceramic Tile and Dimension Stone Installation	Table 303, 303.G.7.c
ANSI B16.32-1992, Cast Copper Alloy Solder Joint Fittings for Solvent Drainage Systems	Table 703
ANSI B16.43-1982, Wrought Copper and Copper Alloy Solder Joint Fittings for Solvent Drainage Systems	Table 703
ANSI B31.1-55, Code for Pressure Piping	621.D
ANSI Z4.1-1986 (R2005)*, Sanitation in Places of Employment, Minimum Requirement for	405.C, Table 411 - Footnote 13
ANSI Z21.10.1-2009, Gas Water Heaters, Volume 1, Storage Water Heaters with Input Ratings of 75,000 Btu per Hour or Less (same as CSA 4.1)	503.B
ANSI Z21.10.3-2011, Gas Water Heaters Volume III, Storage, with Input Ratings Above 75,000 Btu	503.B

Standard Designation	Section/Table
per Hour, circulating and instantaneous (same as CSA 4.3)	
ANSI Z21.22-1999(R2008)*, Relief Valves for Hot Water Supply Systems (same as CSA 4.4M)	501.F.1, 511.A.2, 511.G
ANSI Z124.1.2-2005*, Plastic Bathtub and Shower Units	Table 407, Table 415.I
ANSI Z124.3-2005*, Plastic Lavatories	Table 407
ANSI Z124.4-2006*, Plastic Water Closet Bowls and Tanks	Table 407
ANSI Z535.1-2006 (R2011), American National Standard for Safety Colors	607.A
APSP 2-1999*, Public Spas	Table 415.K
APSP 3-1999*, Permanently Installed Residential Spas	Table 415.K
APSP 6-1999*, Residential Portable Spas	Table 415.K
APSP 16-2011*, Standard Suction Fittings for Use in Swimming Pools, Wading Pools, Spas, and Hot Tubs (same as ASME A112.19.8)	415.K.2, 415.O.6
ARI 1010-2002, Drinking Fountains and Self-Contained, Mechanically-Refrigerated Drinking-Water Coolers	415.C.1
ASME Boiler and Pressure Vessel Code, Section IX, Welding and Brazing Qualifications, 1998 Edition	315.D
ASME A13.1-2007*, Scheme for the Identification of Piping Systems	607.A.1, 607.A.3, 607.B
ASME A112.1.2-2004*, Air Gaps in Plumbing Systems	415.C.1, 415.C.2, 609.A.1, Table 609, 609.C.7, 609.F.2
ASME A112.3.1-2007*, Stainless Steel Drainage Systems for Sanitary DWV, Storm, and Vacuum Applications, Above- and Below Ground	703.C.1, 703.D, Table 703
ASME A112.3.4-2000*, Macerating Toilet Systems and Related Components	Table 407, 729.C
ASME A112.4.1-2009, Water Heater Relief Valve Drain Tubes	Table 511
ASME A112.6.1M-1997 (R2002)*, Supports for Off-the-Floor Plumbing Fixtures for Public Use (Floor -Affixed)	Table 303
ASME A112.6.2-2000*, Framing-Affixed Supports for Off-the-Floor Water Closets with Concealed Tanks	Table 303
ASME A112.6.3-2001*, Floor Drains	Table 303
ASME A112.6.4-2003 (R2008)*, Roof, Deck, and Balcony Drains (dual roof drain assemblies wherein the inlets of both are enclosed in the same strainer are prohibited)	Table 303
ASME A112.14.1-2003 (R2008)*, Backwater Valves	705.G.2
ASME A112.14.3-2000 (R2004)*, Grease Interceptors	1005.N.1, 1005.N.5.a, 1005.N.6.a
ASME A112.18.1-2005*, Plumbing Fixture Fittings (same as CSA B125.1)	Table 407
ASME A112.18.2-2011, Plumbing Waste Fittings (Same as CSA B125.2)	Table 407
ASME A112.18.3-2002*, Requirements for Backflow Protection Devices and Systems in Plumbing Fixture Fittings	Table 407, 609.C.7
ASME A112.18.6-2009, Flexible Water Connectors (same as CSA B125.6)	Table 407, 509.B
ASME A112.19.1-2008*, Enameled Cast Iron and Enameled Steel Plumbing Fixtures (same as CSA B45.2)	Table 407, 415.C.1
ASME A112.19.2-2008*, Ceramic Plumbing Fixtures (same as CSA B45.1)	Table 407, 415.C.1
ASME A112.19.3-2008*, Stainless Steel Plumbing Fixtures (same as CSA B45.4)	Table 407
ASME A112.19.4M-1994 (R2008)*, Porcelain Enameled Formed Plumbing Fixtures	Table 407
ASME A112.19.5-2011, Trim for Water-Closet	Table 407

PUBLIC HEALTH—SANITARY CODE

Standard Designation	Section/Table
Bowls, Tanks and Urinals (same as CSA B45.15)	
ASME A112.19.6-1995*, Hydraulic Performance Requirements for Water Closets & Urinals	Table 407
ASME A112.19.7-2012, Hydromassage Bathtub Systems (same as CSA B45.10)	415.O.4, 415.O.5
ASME A112.19.8-2007*, Suction Fittings for Use in Swimming Pools, Wading Pools, Spas, and Hot Tubs (same as APSP 16)	415.K.2, 415.O.6
ASME A112.19.9M-1991 (R2002)*, Non-vitreous Ceramic Plumbing Fixtures	Table 407
ASME A112.19.19-2006, Vitreous China Nonwater Urinals	Table 407
ASME A112.36.2M-1991 (R2002)*, Cleanouts	Table 303
ASME B1.20.1-1983 (R2006)*, Pipe Threads, General Purpose (Inch)	313.B
ASME B16.3-2011, Malleable Iron Threaded Fittings, Classes 150 and 300	Table 603
ASME B16.4-2011, Gray Iron Threaded Fittings, Classes 125 and 250	Table 603
ASME B16.5-2009, Pipe Flanges and Flanged Fittings	Table 603
ASME B16.12-2009, Cast-Iron Threaded Drainage Fittings	Table 703
ASME B16.15-2011, Cast Bronze Threaded Fittings, Classes 125 and 250	Table 603
ASME B16.18-2001, Cast Copper Alloy Solder Joint Pressure Fittings	Table 603
ASME B16.22-2001*, Wrought Copper and Copper Alloy Solder Joint Pressure Fittings	Table 603
ASME B16.23-2011, Cast Copper Alloy Solder Joint Drainage Fittings-DWV	Table 703
ASME B16.24-2011, Cast Copper Alloy Pipe Flanges: Class 150, 300, 400, 600, 900, 1500, and 2500	Table 603
ASME B16.26-2006*, Cast Copper Alloy Fittings for Flared Copper Tubes	Table 603
ASME B 16.29-2007*, Wrought Copper and Wrought Copper Alloy Solder Joint Drainage Fittings-DWV	Table 703
ASME B16.34-2009, Valves-Flanged Threaded, and Welding End	Table 603
ASME B16.45-1998 (R2006)*, Cast Iron Fittings for Solvent Drainage Systems	1811.E.3
ASSE 1001-2008*, Performance Requirements for Atmospheric-Type Vacuum Breakers	Table 609
ASSE 1002-2008*, Anti-Siphon Fill Valves for Water Closet Tanks	Table 609
ASSE 1003-2009*, Performance Requirements for Water Pressure Reducing Valves for Domestic Water Distribution Systems	611.J.1, 611.J.6
ASSE 1010-2004*, Performance Requirements for Water Hammer Arresters	Table 407, 611.I.1
ASSE 1011-2004*, Performance Requirements for Hose Connection Vacuum Breakers	Table 609
ASSE 1012-2009*, Performance Requirements for Backflow Preventers with Intermediate Atmospheric Vent	Table 609, 609.C.5
ASSE 1013-2011*, Performance Requirements for Reduced Pressure Principle Backflow Preventers and Reduced Pressure Principle Fire Protection Backflow Preventers	Table 609, 609.C.5
ASSE 1014-2005, Performance Requirements for Backflow Prevention Devices for Hand Held Showers	Table 303
ASSE 1015-2011*, Performance Requirements for Double Check Backflow Prevention Assemblies and Double Check Fire Protection Backflow Prevention Assemblies	Table 609

Standard Designation	Section/Table
ASSE 1016-2011*, Performance Requirements for Automatic Compensating Valves for Individual Showers and Tub/Shower Combinations	Table 623, 623.A.1, 623.A.2
ASSE 1017-2009*, Performance Requirements for Temperature Actuated Mixing Valves for Hot Water Distribution Systems	623.A, Table 623
ASSE 1018-2001*, Performance Requirements for Trap Seal Primer Valves - Potable Water Supplied	415.E.4.a, 625.D.1
ASSE 1019-2011*, Performance Requirements for Vacuum Breaker Wall Hydrants, Freeze Resistant, Automatic Draining	Table 303, Table 609
ASSE 1020-2004*, Pressure Vacuum Breaker Assembly	Table 609
ASSE 1022-2003*, Backflow Preventers for Beverage Dispensing Equipment	Table 609
ASSE 1035-2008*, Performance Requirements for Laboratory Faucet Backflow Preventers	Table 303, Table 609
ASSE 1037-1990, Performance Requirements for Pressurized Flushing Devices (Flushometers) for Plumbing Fixtures	Table 303
ASSE 1043-1992, Performance Standard for Cast Iron Solvent Sanitary Drainage Systems	1811.E.3
ASSE 1044-2001*, Performance Requirements for Trap Seal Primer Devices, Drainage Types and Electronic Types	415.E.4
ASSE 1047-2011*, Performance Requirements for Reduced Pressure Detector Fire Protection Backflow Prevention Assemblies	Table 609
ASSE 1048-2011*, Performance Requirements for Double Check Detector Fire Protection Backflow Prevention Assemblies	Table 609
ASSE 1052-2004*, Performance Requirements for Hose Connection Backflow Preventers	Table 609
ASSE 1056-2001*, Performance Requirements for Spill Resistant Vacuum Breakers	Table 609
ASSE 1061-2011*, Performance Requirements for Push-Fit Fittings (for use on PEX tubing complying with ASTM F 876 or F877, type K and L hard drawn and annealed copper tubing complying with ASTM B 88, and CPVC tubing complying with ASTM D 2846)	Table 603
ASSE 1069-2005*, Performance Requirements for Automatic Temperature Control Mixing Valves	Table 623, 623.A.1
ASSE 1070-2004*, Performance Requirements for Water Temperature Limiting Devices	Table 623, 623.B, 623.C
ASSE 1072-2007, Performance Requirements for Barrier Type Floor Drain Trap Seal Protection Devices	415.E.4
ASSE Series 5000-2009*, Cross-Connection Control Professional Qualifications Standard	319.F, Table 609, 609.F
ASSE 5110-2009, Backflow Prevention Assembly Tester Professional Qualifications Standard (part of ASSE Series 5000, Cross-Connection Control Professional Qualifications Standard)	609.F.9
ASSE 5120-2009, Backflow Prevention Assembly Surveyor Professional Qualifications Standard (part of ASSE Series 5000, Cross-Connection Control Professional Qualifications Standard)	607.C
ASSE 5130-2009, Backflow Prevention Assembly Repairer (part of ASSE Series 5000, Cross-Connection Control Professional Qualifications Standard)	609.F.9
ASTM A48/A48M-2003 (R2008), Standard Specification for Gray Iron Castings	Table 703, 717.G
ASTM A53/A53M-2012, Standard Specification for Pipe, Steel, Black and Hot-Dipped, Zinc-Coated Welded and Seamless	Table 603
ASTM A74-2009, Standard Specification for Cast Iron Soil Pipe and Fittings	303.G.6.a, Table 703
ASTM A126-2004 (R2009), Standard Specification for Gray Iron Castings for Valves,	Table 603, Table 619.D



Standard Designation	Section/Table
Flanges, and Pipe Fittings	
ASTM A197/A197M-2000 (R2011), Standard Specification for Cupola Malleable Iron	Table 603
ASTM A2692010, Standard Specification for Seamless and Welded Austenitic Stainless Steel Tubing for General Service	Table 603
ASTM A312/A312M-2012, Standard Specification for Seamless, Welded, and Heavily Cold Worked Austenitic Stainless Steel Pipes	Table 603
ASTM A377-2003 (R2008)e1, Standard Index of Specifications for Ductile-Iron Pressure Pipe	Table 603
ASTM A518/A518M-1999 (R2008), Standard Specification for Corrosion-Resistant High-Silicon Iron Castings	Table 703, 703.F
ASTM A653/ A653M-2011, Standard Specification for Steel Sheet, Zinc-Coated (Galvanized) or Zinc-Iron Alloy-Coated (Galvannealed) by the Hot-Dip Process	Table 303
ASTM A733-2003 (R2009)e1, Standard Specification for Welded and Seamless Carbon Steel and Austenitic Stainless Steel Pipe Nipples	Table 603
ASTM A746-2009, Standard Specification for Ductile Iron Gravity Sewer Pipe	Table 703
ASTM A778-2001 (R2009)e1, Standard Specification for Welded, Unannealed Austenitic Stainless Steel Tubular Products	Table 603
ASTM A865/A865M-2006, Standard Specification for Threaded Couplings, Steel, Black and Zinc-Coated (Galvanized) Welded and Seamless, for Use in Steel Pipe Joints	Table 603
ASTM A888-2011, Standard Specification for Hubless Cast Iron Soil Pipe and Fittings for Sanitary and Storm Drain, Waste, and Vent Piping Applications	Table 703
ASTM B32-2008, Standard Specification for Solder Metal	Table 303
ASTM B42-2010, Standard Specification for Seamless Copper Pipe, Standard Sizes	Table 603
ASTM B43-2009, Standard Specification for Seamless Red Brass Pipe, Standard Sizes	Table 603
ASTM B75/B75M-2011, Standard Specification for Seamless Copper Tube	Table 603
ASTM B88-2009, Standard Specification for Seamless Copper Water Tube	513.F.1, Table 603, 613.A.1, 619.A.2, 619.B
ASTM B135-2008a, Standard Specification for Seamless Brass Tube	Table 603
ASTM B135-2010, Standard Specification for Seamless Brass Tube	Table 603
ASTM B152/B152M-2009, Standard Specification for Copper Sheet, Strip, Plate and Rolled Bar	Table 303
ASTM B248-2007, Standard Specification for General Requirements for Wrought Copper and Copper- Alloy Plate, Sheet, Strip, and Rolled Bar	Table 303
ASTM B248M-2007, Standard Specification for General Requirements for Wrought Copper and Copper- Alloy Plate, Sheet, Strip, and Rolled Bar Metric	Table 303
ASTM B251-2010, Standard Specification for General Requirements for Wrought Seamless Copper and Copper-Alloy Tube	Table 603
ASTM B251M-2010, Standard Specification for General Requirements for Wrought Seamless Copper and Copper-Alloy Tube Metric	Table 603
ASTM B302-2007, Standard Specification for Threadless Copper Pipe, Standard Sizes	Table 603
ASTM B306-2009, Standard Specification for Copper Drainage Tube (DWV)	Table 703
ASTM B447-2007, Standard Specification for Welded Copper Tube	Table 603
ASTM B543-2007e1, Standard Specification for	Table 703

Standard Designation	Section/Table
Welded Copper and Copper-Alloy Heat Exchanger Tube	
ASTM B587-2008, Standard Specification for Welded Brass Tube	Table 603
ASTM B687-1999 (R2011), Standard Specification for Brass, Copper, and Chromium-Plated Pipe Nipples	Table 603
ASTM B813-2010, Standard Specification for Liquid and Paste Fluxes for Soldering Applications for Copper and Copper Tube	Table 303
ASTM B828-2002 (R2010), Standard Practice for Making Capillary Joints by Soldering of Copper and Copper Alloy Tube and Fittings	Table 303
ASTM C4-2004 (R2009), Standard Specification for Clay Drain Tile and Perforated Clay Drain Tile	Table 703
ASTM C14-2011, Standard Specification for Non-Reinforced Concrete Sewer, Storm Drain, and Culvert Pipe (Approved for storm drain use only)	Table 703
ASTM C76-2011, Standard Specification for Reinforced Concrete Culvert, Storm Drain, and Sewer Pipe (Approved for storm drain use only)	Table 703
ASTM C76M-2011, Standard Specification for Reinforced Concrete Culvert, Storm Drain, and Sewer Pipe-Metric (Approved for storm drain use only)	Table 703
ASTM C361-2011, Standard Specification for Reinforced Concrete Low-Head Pressure Pipe (Approved for storm drain use only)	Table 703
ASTM C361M-2008, Standard Specification for Reinforced Concrete Low-Head Pressure Pipe-Metric (Approved for storm drain use only)	Table 703
ASTM C412-2011, Standard Specification for Concrete Drain Tile	Table 703
ASTM C412M-2011, Standard Specification for Concrete Drain Tile Metric	Table 703
ASTM C425-2004 (R2009), Standard Specification for Compression Joints for Vitrified Clay Pipe and Fittings	Table 703, 313.E
ASTM C443-2011, Standard Specification for Joints for Concrete Pipe and Manholes, Using Rubber Gaskets	Table 303
ASTM C443M-2011, Standard Specification for Joints for Concrete Pipe and Manholes, Using Rubber Gaskets Metric	Table 303
ASTM C444-2003 (R2009), Standard Specification for Perforated Concrete Pipe	Table 703
ASTM C444M-2003(2009), Standard Specification for Perforated Concrete Pipe Metric	Table 703
ASTM C478-2012, Standard Specification for Precast Reinforced Concrete Manhole Sections	Table 703, 717.G
ASTM C478M-2011, Standard Specification for Precast Reinforced Concrete Manhole Sections Metric	Table 703, 710.7
ASTM C564-2011, Standard Specification for Rubber Gaskets for Cast Iron Soil Pipe and Fittings	Table 303, 709.D.3
ASTM C700-2011, Standard Specification for Vitrified Clay Pipe, Extra Strength, Standard Strength, and Perforated	Table 703
ASTM C1053-2000 (R2010), Standard Specification for Borosilicate Glass Pipe and Fittings for Drain, Waste, and Vent (DWV) Applications	Table 703, 703.F
ASTM C1173-2010e1, Standard Specification for Flexible Transition Couplings for Underground Piping Systems	Table 303
ASTM C1277-2011, Standard Specification for Shielded Couplings Joining Hubless Cast Iron Soil Pipe and Fittings	Table 303
ASTM D395-2003 (R2008), Standard Test Methods for Rubber Property-Compression Set. See §711.D of this code	Table 303

PUBLIC HEALTH—SANITARY CODE

Standard Designation	Section/Table
ASTM D412-2006ae2, Standard Test Methods for Vulcanized Rubber and Thermoplastic Elastomers-Tension. See §711.D of this code	Table 303
ASTM D788-2011, Standard Specification for Poly (Methyl Methacrylate) (PMMA) Molding and Extrusion Compounds	Table 303
ASTM D 789-2007e1, Standard Test Methods for Determination of Solution Viscosities of Polyamide (PA)	Table 303
ASTM D1527-99 (R2005), Standard Specification for Acrylonitrile- Butadiene-Styrene (ABS) Plastic Pipe, Schedules 40 and 80	Table 603
ASTM D1785-2006, Standard Specification for Poly (Vinyl Chloride) (PVC) Plastic Pipe, Schedules 40, 80, and 120	Table 603
ASTM D1869-1995 (R2010), Standard Specification for Rubber Rings for Asbestos-Cement Pipe	Table 303
ASTM D2235-2004 (R2011), Standard Specification for Solvent Cement for Acrylonitrile-Butadiene-Styrene (ABS) Plastic Pipe and Fittings. Listed	Table 303
ASTM D2239-2012, Standard Specification for Polyethylene (PE) Plastic Pipe (SIDR-PR) Based on Controlled Inside Diameter	Table 603
ASTM D2241-2009, Standard Specification for Poly (Vinyl Chloride) (PVC) Pressure-Rated Pipe (SDR-Series). Listed	Table 603
ASTM D2321-2011, Standard Practice for Underground Installation of Thermoplastic Pipe for Sewers and Other Gravity-Flow Applications	Table 303, Table 703
ASTM D2466-2006, Standard Specification for Poly (Vinyl Chloride) (PVC) Plastic Pipe Fittings Schedule 40	Table 603
ASTM D2467-2006, Standard Specification for Poly (Vinyl Chloride) (PVC) Plastic Pipe Fittings, Schedule 80. Listed	Table 603
ASTM D 2564-2004 (R2009)e1*, Standard Specification for Solvent Cements for Poly(Vinyl Chloride)(PVC) Plastic Piping Systems. Listed	Table 303
ASTM D2657-2007, Standard Practice for Heat Fusion Joining of Polyolefin Pipe and Fittings	Table 303
ASTM D2661-2011, Standard Specification for Acrylonitrile Butadiene-Styrene (ABS) Plastic Drain, Waste and Vent Pipe and Fittings. Listed	Table 703
ASTM D2665-2011, Standard Specification for Poly (Vinyl Chloride) (PVC) Plastic Drain, Waste, and Vent Pipe and Fittings. Listed	Table 703
ASTM D2672-1996a (2009)*, Standard Specification for Joints for IPS PVC Pipe Using Solvent Cement	Table 603
ASTM D2737-2012e1, Standard Specification for Polyethylene (PE) Plastic Tubing. Listed	Table 603
ASTM D2751-2005, Standard Specification for Acrylonitrile- Butadiene-Styrene (ABS) Sewer Pipe and Fittings	Table 703
ASTM D2774-2012, Standard Practice for Underground Installation of Thermoplastic Pressure Piping	Table 303
ASTM D2846/D2846M-2009be1, Standard Specification for Chlorinated Poly(Vinyl Chloride)(CPVC) Plastic Hot-and Cold-Water Distribution Systems. Listed	Table 603
ASTM D 2855-1996 (R2010), Standard Practice for Making Solvent-Cemented Joints with Poly (Vinyl Chloride)(PVC) Plastic Pipe and Fittings	Table 303
ASTM D3034-2008, Standard Specification for Type PSM Poly (Vinyl Chloride) (PVC) Sewer Pipe and Fittings	Table 703
ASTM D-3138-04(2011), Standard Specification for Solvent Cements for Transition Joints Between Acrylonitrile-Butadiene-Styrene (ABS) and	Table 303, 711.D.4 Note: This is not an all-purpose

Standard Designation	Section/Table
Poly(Vinyl Chloride) (PVC) Non-Pressure Piping Components	cement. Only to be utilized for joining an ABS building drain to a PVC building sewer.
ASTM D3139-1998 (R2011), Standard Specification for Joints for Plastic Pressure Pipes Using Flexible Elastomeric Seals. See §313.H.2 of this code	Table 603
ASTM D3212-2007*, Standard Specification for Joints for Drain and Sewer Plastic Pipes Using Flexible Elastomeric Seals	Table 703
ASTM D4068-2009, Standard Specification for Chlorinated Polyethylene (CPE) Sheeting for Concealed Water-Containment Membrane	303.G.7, Table 415.I
ASTM D4551-1996 (2008)e1*, Standard Specification for Poly (Vinyl Chloride) (PVC) Plastic Flexible Concealed Water-Containment Membrane	303.G.7, Table 415.I
ASTM D4894-2007, Standard Specification for Polytetrafluoroethylene (PTFE) Granular Molding and Ram Extrusion Materials	Table 303
ASTM D4895-2010, Standard Specification for Polytetrafluoroethylene (PTFE) Resin Produced From Dispersion	Table 303
ASTM F402-2005 (R2012), Standard Practice for Safe Handling of Solvent Cements, Primers, and Cleaners Used for Joining Thermoplastic Pipe and Fittings	Table 303
ASTM F409-2002 (R2008), Standard Specification for Thermoplastic Accessible and Replaceable Plastic Tube and Tubular Fittings	Table 703
ASTM F437-2009, Standard Specification for Threaded Chlorinated Poly (Vinyl Chloride) (CPVC) Plastic Pipe Fittings, Schedule 80. Listed	Table 603
ASTM F438-2009, Standard Specification for Socket-Type Chlorinated Poly(Vinyl Chloride) (CPVC) Plastic Pipe Fittings, Schedule 40	Table 603
ASTM F439-2011, Standard Specification for Chlorinated Poly (Vinyl Chloride) (CPVC) Plastic Pipe Fittings, Schedule 80. Listed	Table 603
ASTM F441/F 441M-2009, Standard Specification for Chlorinated Poly (Vinyl Chloride) (CPVC) Plastic Pipe, Schedules 40 and 80. Listed	Table 603
ASTM F442/F 442M-2009, Standard Specification for Chlorinated Poly (Vinyl Chloride) (CPVC) Plastic Pipe (SDR-PR)	Table 603
ASTM F493-2010, Standard Specification for Solvent Cements for Chlorinated Poly(Vinyl Chloride)(CPVC) Plastic Pipe and Fittings	Table 303
ASTM F628-2008, Standard Specification for Acrylonitrile- Butadiene-Styrene (ABS) Schedule 40 Plastic Drain, Waste, and Vent Pipe with a Cellular Core. Listed.	Table 703
ASTM F 656-2010*, Standard Specification for Primers for Use in Solvent Cement Joints of Poly(Vinyl Chloride) (PVC) Plastic Pipe and Fittings	Table 303
ASTM F876-2010e1, Standard Specification for Crosslinked Polyethylene (PEX) Tubing	Table 603
ASTM F877-2011a, Standard Specification for Crosslinked Polyethylene (PEX) Plastic Hot and Cold-Water Distribution Systems, Listed	Table 603
ASTM F891-2010, Standard Specification for Coextruded Poly(Vinyl Chloride)(PVC) Plastic Pipe with a Cellular Core	Table 703
ASTM F1281-2011, Standard Specification for Crosslinked Polyethylene/Aluminum/Crosslinked Polyethylene (PEX-AL-PEX) Pressure Pipe	Table 603
ASTM F1282-2010, Standard Specification for Polyethylene/ Aluminum/Polyethylene (PE-AL-PE) Composite Pressure Pipe	Table 603

Standard Designation	Section/Table
ASTM F1290-1998a (R2011), Standard Practice for Electro fusion Joining Polyolefin Pipe and Fittings	Table 303, 621.E.2
ASTM F1412-2009, Standard Specification for Polyolefin Pipe and Fittings for Corrosive Waste Drainage Systems	Table 703, 703.F, 709.C
ASTM F1488-2009e1, Standard Specification for Coextruded Composite Pipe	Table 703
ASTM F1499-2012, Standard Specification for Coextruded Composite Drain, Waste, and Vent Pipe (DWV)	Table 703
ASTM F1673-2010, Standard Specification for Polyvinylidene Fluoride (PVDF) Corrosive Waste Drainage Systems	Table 703, 703.F
ASTM F1807-2011a e1, Standard Specification for Metal Insert Fittings Utilizing a Copper Crimp Ring for SDR9 Cross-linked Polyethylene (PEX) Tubing	Table 603
ASTM F1960-2011e1, Standard Specification for Cold Expansion Fittings with PEX Reinforcing Rings for Use with Cross-linked Polyethylene (PEX) Tubing	Table 603
ASTM F2159-2011, Standard Specification for Plastic Insert Fittings Utilizing a Copper Crimp Ring for SDR9 Cross-linked Polyethylene (PEX) Tubing	Table 603
ASTM F2080-2009, Standard Specification for Cold-Expansion Fittings With Metal Compression-Sleeves for Cross-Linked Polyethylene (PEX) Pipe	Table 603
ASTM F2098-2008, Standard Specification for Stainless Steel Clamps for Securing SDR9 Cross-linked Polyethylene (PEX) Tubing to Metal Insert and Plastic Insert Fittings	Table 603
ASTM F2389-2010, Standard Specification for Pressure-rated Polypropylene (PP) Piping Systems	Table 603, 619.B
ASTM F2618-2009, Standard Specification for Chlorinated Poly (Vinyl Chloride) (CPVC) Pipe and Fittings for Chemical Waste Drainage Systems	Table 703, 703.F
ASTM F2620-2011e1, Standard Practice for Heat Fusion Joining of Polyethylene Pipe and Fittings	Table 303, 621.E
AWS B2.2/B2.2M:2010, Specification for Brazing Procedure and Performance Qualification	315.D
AWS A5.8/A5.8M-2011, Spec. for Filler Metals for Brazing and Braze Welding	Table 303
AWS A5.9/5.9M-2006*, Specification for Bare Stainless Steel Welding Electrodes and Rods	Table 303, 621.G
AWWA C104-2008*, Cement-Mortar Lining for Ductile-Iron Pipe and Fittings for Water (same as ANSI A21.4)	Table 303
AWWA C110-2008 (R2012)*, Ductile-Iron and Gray-Iron Fittings (same as ANSI A21.10)	Table 603
AWWA C111-2006*, Rubber Gasket Joints for Ductile-Iron and Gray-Iron Pressure Pipe and Fittings (same as ANSI A21.11)	709.G
AWWA C151-2009*, Ductile-Iron Pipe, Centrifugally Cast (same as ANSI A21.51)	Table 603
	Table 603
AWWA C203-2009*, Coal-Tar Protective Coatings and Linings for Steel Water Pipelines-Enamel and Tape-Hot-Applied	Table 303
AWWA C509-2009*, Resilient-Seated Gate Valves for Water Service Supply	Table 619.D
AWWA C510-2007*, Double Check Valve Backflow Prevention Assembly	Table 609
AWWA C511-2007*, Reduced Pressure Principle Backflow Prevention Assembly	Table 609
AWWA C606-2011*, Grooved and Shouldered Joints	Table 303
AWWA C900-2007*, Polyvinyl Chloride (PVC) Pressure Pipe and Fabricated Fittings, 4 In. Through 12 In. (100 mm Through 300 mm), for	Table 603

Standard Designation	Section/Table
Water Transmission and Distribution	
CAN/CSA-B64.10-94, Manual for the Selection, Installation, Maintenance, and Field Testing of Backflow Prevention Devices	Table 609, Table 609.F.5 - Footnote 1, Table 609.F.6 - Footnotes 2 & 3
CAN/CSA-B137.2-2009, PVC Injection-Molded Gasketed Fittings for Pressure Applications. Listed	Table 603
CAN/CSA-B 137.5-2009, Cross-Linked Polyethylene (PEX) Tubing Systems for Pressure Applications. Listed	Table 603
CAN/CSA-B181.1-2006, ABS Drain, Waste, and Vent Pipe and Pipe Fittings	705.G.2
CAN/CSA-B 181.2-2006, PVC Drain, Waste, and Vent Pipe and Pipe Fittings	705.G.2
CAN/CSA-B-182.4-2006, Profile PVC Sewer Pipe and Fittings	Table 703
CDA Copper Sovent Single Stack Plumbing System Design Handbook No. 402/0 (For informational purposes only since is alternate designed plumbing governed under Chapter 12 requirements of this code)	1811.E.3
CDA Copper Tube Handbook (For informational purposes only)	Table 1805.F
CISPI HS 74-86, Standard Specification for Cast Iron Soil Pipe and Fittings for Hub and Spigot Sanitary and Storm Drain, Waste and Vent Piping Applications	Table 703
CISPI HSN 85, Standard Specification for Neoprene Rubber Gaskets for Hub and Spigot Cast Iron Soil Pipe and Fittings	Table 303
CISPI 301-09, Standard Specification for Hubless Cast Iron Soil Pipe and Fittings for Sanitary and Storm Drain, Waste, and Vent Piping Applications	Table 703
CISPI 310-11, Standard Specification for Coupling for use in connection with Hubless Cast Iron Soil Pipe and Fittings for Sanitary and Storm Drain, Waste, and Vent Piping Applications	Table 303, Table 703, 709.E.3
CSA 4.1-2009, Gas Water Heaters, Volume 1, Storage Water Heaters with Input Ratings of 75,000 Btu per Hour or Less (same as ANSI Z21.10.1)	503.B
CSA 4.3-2011, Gas Water Heaters Volume III, Storage, with Input Ratings Above 75,000 Btu per Hour, circulating and instantaneous (same as ANSI Z21.10.3)	503.B
CSA 4.4M-1999(R2008)*, Relief Valves for Hot Water Supply Systems (same as ANSI Z21.22)	501.F.1, 511.A.2, 511.G
CSA B45.1-2008, Ceramic Plumbing Fixtures (same as ASME A112.19.2)	Table 407, 415.C.1
CSA B45.2-2008, Enameled Cast Iron and Enameled Steel Plumbing Fixtures (same as ASME A112.19.1)	Table 407, 415.C.1
CSA B45.4-2008, Stainless Steel Plumbing Fixtures (same as ASME A112.19.3)	Table 407
CSA B45.10-2012, Hydromassage Bathtub Systems (same as ASME A112.19.7)	415.O.4, 415.O.5
CSA B45.15-2011, Trim for Water-Closet Bowls, Tanks and Urinals (same as ASME A112.19.5)	Table 407
CSA B125.1-2005, Plumbing Supply Fittings (same as ASME A112.18.1)	Table 407
CSA B125.2-2011, Plumbing Waste Fittings (same as ASME A112.18.2)	Table 407
CSA B125.6-2009, Flexible Water Connectors (same as ASME A112.18.6)	Table 407, 509.B
FMRC 1680-89, Couplings Used In Hubless Cast Iron Systems for Drain, Waste or Vent, Sewer, Rainwater or Storm Drain Systems Above and Below Ground, Industrial/Commercial and Residential	Table 303
FS QQ-L-156 (1946), Caulking Lead	Table 407
FS QQ-L-201 F(2) (1965) (R1970), Lead Sheet,	Table 303

PUBLIC HEALTH—SANITARY CODE

Standard Designation	Section/Table
[AMD 02 (1970)]	
FS SS-P-381, Concrete Pipe Pressure Reinforced-Pretention Reinforcement Steel	Table 703
FS WW-P-325(44), Pipe, Bends, Traps, Caps, and Plugs; Lead (for Industrial Pressure, and Soil and Waste Applications)	Table 703
FS WW-P-541 E/GEN(1), (1980), Plumbing Fixtures (General Specifications), [AMD 01 (1990)]	Table 407
IAPMO Z124.5-2006, Plastic Toilet (Water Closet) Seats	Table 303
IAPMO Z124.6-2007, Plastic Sinks	Table 407
MSS SP-72-2010, Ball Valves with Flanged or Butt-Welding Ends for General Service	Table 609.D
MSS SP-80-2008, Bronze Gate, Globe, Angle and Check Valves	Table 609.D
MSS SP-110-2010, Ball Valves Threaded, Socket-Welding, Solder Joint, Grooved, and Flared Ends	Table 609.D
NFPA 70-2010 National Electrical Code	731.H.2, 1101.G.3
NFPA 99-2012, Health Care Facilities Code	1302, G105
NFPA1192-2008, Standard on Recreational Vehicles	1501.A, 1601.A
NSF 14-2011*, Plastic Piping System Components and Related Materials	303.H.5, 313.H.1
NSF 24-2010*, Plumbing System Components for Mobile Homes & Recreational Vehicles	Table 603
NSF 42-2010*, Drinking Water Treatment Units-Aesthetic Effects	Table 303, 627.A
NSF 50-2011*, Circulation System Components and Related Materials for Swimming Pools, Spas or Hot Tubs	415.K.1
NSF 53-2011*, Drinking Water Treatment Units-Health Effects	Table 303, 627.A
NSF 58-2006*, Reverse Osmosis Drinking Table Water Treatment Units	Table 303, 627.B
NSF 61-2011*, Drinking Water System Components-Health Effects	303.F, 335.C, 415.C.1
NSF/ANSI 372-2010*, Drinking Water System Components-Lead Content	303.F, 613.A, 619.A.3
PDI-G101-2010, Testing and Rating Procedure for Grease Interceptors with Appendix of Sizing and Installation Data	1005.N.1, 1005.N.5.a, 1005.N.6.a
PDI-WH201-2006, Water Hammer Arresters	611.I.1
SBCCI Standard Building Code, 1994 Edition	203,
UFL's TREEO's "Backflow Prevention - Theory and Practice", 2nd Edition, 2004	319.F
UL 174-2004, Household Electric Storage Tank Water Heaters	503.A
USC's FCCC&HR's "Manual of Cross-Connection Control", Tenth Edition, 2009	319.F

\*ANSI designated as an American National Standard

AUTHORITY NOTE: Promulgated in accordance with R.S. 40:4(A)(7) and R.S. 40:5(2)(3)(7)(9)(16)(17)(20).

HISTORICAL NOTE: Promulgated by the Department of Health and Hospitals, Office of Public Health, LR 38:2886 (November 2012).

**§1405. Organizations**

A. The following is a list by name and address of those agencies, associations, institutes and others that are referred to in this code by name, initials or symbols. Further there are those listed, for convenience, whose technical and other services are made available to this Part.

AGA	American Gas Association, Inc. 400 North Capitol Street, NW, Suite 450 Washington, D.C. 20001
-----	-----------------------------------------------------------------------------------------------------

	Tel. (202)824-7000 www.aga.org
AHRI	Air-Conditioning, Heating, and Refrigeration Institute 2111 Wilson Boulevard, Suite 500 Arlington, Virginia 22201 Tel. (703) 524-8800 Fax (703) 562-1942 www.ahrinet.org
ANSI	American National Standards Institute, Inc. 25 West 43 <sup>rd</sup> Street, 4 <sup>th</sup> Floor New York, New York 10036 Tel. (212) 642-4900 Fax (212) 398-0023 www.ansi.org
ARI	Air Conditioning & Refrigeration Institute (effective January 1, 2008, now AHRI)
APSP	Association of Pool & Spa Professionals (formerly National Spa and Pool Institute) 2111 Eisenhower Avenue, Suite 500 Alexandria, Virginia 22314-4695 Tel. (703) 838-0083 Fax (703) 549-0493 www.apsp.org
ASME	American Society of Mechanical Engineers Information Central - Orders/Inquiries P.O. Box 2300 Fairfield, New Jersey 07007-2300 Tel. (800) 843-2763 www.asme.org
ASSE	American Society of Sanitary Engineering 901 Canterbury, Suite A Westlake, Ohio 44145 Tel. (440) 835-3040 Fax (440) 835-3488 www.asse-plumbing.org
ASTM International	American Society for Testing and Materials International 100 Barr Harbor Drive West Conshohocken, Pennsylvania 19428-2959 Tel. (610) 832-9500 Fax (610) 832-9555 www.astm.org
AWS	American Welding Society 550 N.W. LeJeune Road Miami, Florida 33126 Tel. (305) 443-9353 Tel. (800) 443-9353 Fax (305) 443-7559 www.aws.org
AWWA	American Water Works Association 6666 West Quincy Avenue Denver, Colorado 80235-3098 Tel. (303) 794-7711 Tel. (800) 926-7337 Fax (303) 347-0804
CDA	Copper Development Association, Inc. 260 Madison Ave. New York, New York, New York 10016 Tel. (212) 251-7200 Fax (212) 251-7234 www.copper.org
CISPI	Cast Iron Soil Pipe Institute 5959 Shallowford Road, Suite 419 Chattanooga, Tennessee 37421 Tel. (423) 892-0137 www.cispi.org
CAN/CSA	Canadian Standards Association 5060 Spectrum Way, Suite 100 Mississauga, Ontario Canada L4W 5N6 Tel. (416) 747-4000 Tel. (800) 463-6727 www.csa.ca

FMRC	Factory Mutual Research Corporation FM Approvals, LLC Approval Standards 1151 Boston-Providence Turnpike, P.O. Box 9102 Norwood, Massachusetts 02062-9102 Tel. (781) 762-4300 Fax (781) 762-9375 www.fmglobal.com
FS	Federal Specifications General Services Administration Federal Supply Service Specification Section 301 7th Street SW, Room 6628 Washington, D.C. 20407 Tel. (202) 619-8925 Fax (202) 619-8985 www.gsa.gov (go to "http://www.gsa.gov/portal/content/100847" for an index of Federal Specifications)
IAPMO	International Association of Plumbing and Mechanical Officials 5001 E. Philadelphia Street Ontario, California 91761-2816 Tel. (909) 472-4100 Fax (909) 472-4150 www.iapmo.org
MSS	Manufacturers Standardization Society of the Valve and Fittings Industry, Inc. 127 Park Street, N.E. Vienna, Virginia 22180-4602 Tel. (703) 281-6613 Fax (703) 281-6671 MSS-hq.org
NFiPA	National Fire Protection Association 1 Batterymarch Park Quincy, Massachusetts 02169-9101 Tel. (617) 770-3000 Tel. (800) 344-3555 Fax (800) 593-6372 www.nfpa.org
NSF	NSF International 789 N. Dixboro Road P.O. Box 130140 Ann Arbor, Michigan 48113-0140 Tel. (734) 769-8010 Tel. (800) 673-6275 Fax (734) 769-0109 www.nsf.org
PDI	Plumbing and Drainage Institute 800 Turnpike Street, Suite 300 North Andover, Massachusetts 01845 Tel. (800) 589-8956 Tel. (978) 557-0720 Fax (978) 557-0721 www.pdionline.org
PPFA	Plastic Pipe & Fittings Association 800 Roosevelt Road, Building C, Suite 312 Glen Ellyn, Illinois 60137-5833 Tel. (630) 858-6540 Fax (630) 790-3095 www.ppfahome.org
PPI	Plastics Pipe Institute A Division of the Plastics Industry, Inc. 105 Decker Court, Suite 825 Irving, Texas 75062 Tel. (469) 499-1044 Fax (469) 499-1063 www.plasticpipe.org (Note: "more PE pipe focus")
UFL's TREEO	University of Florida Center for Training, Research and Education for Environmental Occupations 3900 SW 63 Blvd Gainesville, FL 32608

	Tel. (352) 392-9570 x229 Fax (352) 392- www.treeo.ufl.edu/backflow
UL	Underwriters Laboratories, Inc.** 333 Pfingsten Road Northbrook, Illinois 60062-2096 Tel. (847) 272-8800 Fax (847) 272-8129 www.ul.com
**UL Standards available from:	
	IHS Global Engineering Documents 15 Inverness Way East Englewood, Colorado 80112-5776 Tel. (303) 397-7956 Tel. (800) 854-7179 Fax (303) 397-2740 www.global.ihs.com
USC's FCCC&HR	University of Southern California Foundation for Cross-Connection Control and Hydraulic Research Viterbi School of Engineering Kapelrian Hall 200 Los Angeles, CA 90089-2531 Tel. (866) 545-6340 Fax (213) 740-8399 www.usc.edu/fccchr

AUTHORITY NOTE: Promulgated in accordance with R.S. 40:4(A)(7) and R.S. 40:5(2)(3)(7)(9)(16)(17)(20).

HISTORICAL NOTE: Promulgated by the Department of Health and Hospitals, Office of Public Health, LR 38:2891 (November 2012).

## Chapter 15. Travel Trailers and Travel Trailer Parks [formerly Appendix B - Travel Trailers and Travel Trailer Parks]

### §1501. General

A. With the exception of §1523 of this code, the requirements set forth in this Chapter shall apply specifically to all new travel trailer parks, and to additions to existing parks as herein defined, and are to provide minimum standards for sanitation and plumbing installation within these parks, for the accommodations, use and parking of travel trailers. Plumbing installations within travel trailers shall be installed in accordance with NFPA 1192.

AUTHORITY NOTE: Promulgated in accordance with R.S. 40:4(A)(7) and R.S. 40:5(2)(3)(7)(9)(16)(17)(20).

HISTORICAL NOTE: Promulgated by the Department of Health and Hospitals, Office of Public Health, LR 38:2892 (November 2012).

### §1503. Definitions

A. Definitions contained in Chapter 2 of this code shall also apply to this Chapter except where the following special definitions shall apply.

*Air Lock*—a condition where air is trapped in a *drain* or *drain hose* and retards or stops the flow of *liquid waste* or *sewage*.

*Center*—the longitudinal center line located midway between the right and the left side of a *mobile/manufactured home* or *travel trailer*.

*Combination Compartment*—a shower stall with or without a door which provides for or includes a water closet. It is sized for occupancy of only one person.

*Department Having Jurisdiction*—the administrative authority/authorities or other law enforcement agency/agencies having jurisdiction over this Code.

*Dependent Travel Trailer*—a travel trailer not equipped with a water closet.

*Drain Hose*—the approved type hose, flexible and easily detachable, used for connecting the *drain outlet* on a *travel trailer* to a *sewer inlet* connection.

*Drain Outlet*—the lowest end of the main drain of a travel trailer itself to which a *drain hose* is connected.

*Independent Mobile/Manufactured Home or Travel Trailer*—a *mobile/manufactured home* or *travel trailer* equipped with a water closet and a bath or shower.

*Inlet Coupling*—the terminal end of the branch water line to which the *mobile/manufactured home* or *travel trailer's* water service connection is made. It may be a swivel fitting or threaded pipe end.

*Intermediate Waste Holding Tank*—(travel trailers only) an enclosed tank for the temporary retention of water-borne waste.

*Length*—the distance measured from the tip of the hitch to the part farthest to the rear of a *mobile/manufactured home* or *travel trailer*.

*Park or Mobile/Manufactured Home Park or Travel Trailer Park*—any lot, tract, parcel or plot of land upon which more than one *travel trailer* and/or *mobile/manufactured homes* parked for the temporary or permanent use of a *person* or *persons* for living, working or congregating.

*Park Drainage System*—the entire system of drainage piping within the *park* which is used to convey *sewage* or other *wastes* from the *mobile/manufactured home* or *travel trailer drain outlet* connection, beginning at its *sewer inlet* connection at the *mobile/manufactured home* or *travel trailer* site, to a *community sewerage system*, a *commercial treatment facility*, or an *individual sewerage system*.

*Park Water Distribution System*—all of the water distribution piping within the *park*, extending from the water supply system or other source of supply to, but not including, the *mobile/manufactured home* or *travel trailer's* water service connection, and including branch service lines, *fixture* devices, service buildings and appurtenances thereto.

*Service Building*—a building housing toilet and bathing facilities for men and women, with laundry facilities.

*Sewer Inlet*—a sewer pipe connection permanently provided at the *travel trailer* or *mobile/manufactured home* site which is designed to receive *sewage* when a *travel*

*trailer* or a *mobile/manufactured home* is parked on such site. It is considered the upstream terminus of the *park drainage system*.

*Sewer Lateral*—that portion of the park drainage system extending from the main to the sewer inlet connection at a *mobile/manufactured home* or *travel trailer* site.

*Trailer Trap*—a device, fitting or assembly of fittings installed in the *sewer lateral* for a *travel trailer* or *mobile/manufactured home* which is used to prevent the circulation of air between the *park drainage system* and the drainage system of the individual *travel trailer* or *mobile/manufactured home*.

*Travel Trailer*—a vehicular unit, mounted on wheels, designed to provide temporary living quarters for recreational, camping, or travel use, of such size or weight as not to require special highway movement permits when towed by a motorized vehicle, and of gross trailer area less than 320 square feet.

*Travel Trailer Sanitary Service Station*—a sewage inlet with cover, surrounded by a concrete apron sloped inward to the *drain*, and watering facilities to permit periodic washdown of the immediately adjacent area, to be used as a disposal point for the contents of *intermediate waste holding tanks* of *travel trailers*.

*Water Service Connection*—as used in conjunction with *mobile/manufactured homes* and *travel trailers*, the water pipe connected between the inlet coupling of the park water distribution system and the water supply fitting provided on the *mobile/manufactured home* or *travel trailer* itself.

AUTHORITY NOTE: Promulgated in accordance with R.S. 40:4(A)(7) and R.S. 40:5(2)(3)(7)(9)(16)(17)(20).

HISTORICAL NOTE: Promulgated by the Department of Health and Hospitals, Office of Public Health, LR 38:2893 (November 2012).

### §1505. General Regulations

A. Governing Provisions. Other general provisions of this code shall govern the installation of plumbing systems in travel trailer parks, except where special conditions or construction are specifically defined in this Chapter.

B. Travel Trailer Sites. Travel trailers shall comply with the following when parked in a travel trailer park.

1. Travel trailers shall not hereafter be parked in any travel trailer park unless there are provided plumbing and sanitation facilities installed and maintained in conformity with these regulations. Every travel trailer shall provide a gastight and watertight connection for sewage disposal which shall be connected to an underground sewage collection system discharging into a community sewerage system, a commercial treatment facility, or an individual sewerage system which has been approved by the state health officer.

2. No dependent travel trailer shall be parked at any time in a space designed and designated for an independent travel trailer unless public toilet and bath facilities are available within 200 ft (61 m) of the dependent travel trailer.

C. Travel Trailer Sanitary Service Station. At least one travel trailer sanitary service station shall be provided in all travel trailer parks that accept any travel trailers having an intermediate waste holding tank.

AUTHORITY NOTE: Promulgated in accordance with R.S. 40:4(A)(7) and R.S. 40:5(2)(3)(7)(9)(16)(17)(20).

HISTORICAL NOTE: Promulgated by the Department of Health and Hospitals, Office of Public Health, LR 38:2893 (November 2012).

### **§1507. Plans and Specifications**

A. The owner or operator of every travel trailer park, before providing areas of space for the use and accommodation of travel trailers, shall make application for a permit (where such permit is required by state, parish, city or other local laws or ordinances) or, regardless of whether or not an actual permit is required, shall file two sets of plans and specifications with the department(s) having jurisdiction for their review and approval. The plans and specifications shall be in detail and shall include/comply with the following:

1. a scaled plot plan of the park, indicating the spaces, area or portion of the park for the parking of travel trailers;
2. the size, location and specification of the park drainage system;
3. the size, location and specification of water supply lines;
4. the size, location and layout of service building (see §1509 of this code);
5. the size, location, specification and layout of the fire protection system, if applicable;
6. a scaled layout of typical trailer sites;
7. applications/submittals shall bear the approval of the local enforcement agencies as to compliance with city or parish plumbing, zoning and health ordinances;
8. plumbing required by this Chapter shall comply with all city, parish and state plumbing and health ordinances and regulations;
9. the issuance of a permit (or an approval of a submittal) shall not constitute approval of any violation of this code or violation of any city or parish ordinance or regulation; and,
10. an approved set of plans and specifications and a copy of the permit (or written approval of a submittal) shall be kept on the park premises until the final inspection has been made.

AUTHORITY NOTE: Promulgated in accordance with R.S. 40:4(A)(7) and R.S. 40:5(2)(3)(7)(9)(16)(17)(20).

HISTORICAL NOTE: Promulgated by the Department of Health and Hospitals, Office of Public Health, LR 38:2894 (November 2012).

### **§1509. Service Buildings**

A. Each travel trailer park shall have at least one service building to provide necessary sanitation and laundry

facilities as specified in §§1509.B through 1509.E of this code. The service building shall be of permanent construction with an interior finish of moisture resistant material which will stand frequent washing and cleaning and the building shall be well-lighted and ventilated at all times.

#### **B. Service Building for Independent Trailers**

1. The service building(s) of only independent travel trailer parks shall have a minimum of one water closet, one lavatory, one shower or bathtub for females and one water closet, one lavatory, and one shower or bathtub for males. In addition, at least one laundry tray or clothes washing machine and one drinking fountain shall be provided.

2. The laundry tray or clothes washing machine and drinking fountain shall be located in a common area. None of these fixtures shall be located within any toilet room.

#### **C. Service Building for Dependent Trailers**

1. The service building(s) in parks that also accommodate dependent travel trailers shall have a minimum of two water closets, one lavatory, one shower or bathtub for females, and one water closet, one lavatory, one urinal, and one shower or bathtub for males. In addition, at least one laundry tray or clothes washing machine and one drinking fountain located in a common area shall be provided. The above facilities are for a maximum of ten dependent travel trailers. For every ten additional dependent travel trailers (or any fraction thereof) the following additional fixtures shall be provided: One laundry tray or clothes washing machine, one shower or bathtub for each sex, and one water closet for females. Also, one additional water closet for males shall be provided for every 15 additional dependent travel trailers (or any fraction thereof).

2. The laundry tray(s) and/or clothes washing machine(s) and drinking fountain(s) shall be located in a common area. None of these fixtures shall be located within any toilet room.

D. Hot and cold water shall be provided for all plumbing fixtures except water closets, urinals and drinking fountains.

E. Each water closet, tub and/or shower shall be in separate compartments, with self-closing doors on all water closet compartments. The shower stall shall be a minimum of 3 x 3 ft (914 x 914 mm) in area, with a dressing compartment with a stool or bench for females.

F. Floor Drains. A minimum 2-inch floor drain protected by and approved trap primer shall be installed in each toilet room and laundry room (see §415.E of this code).

AUTHORITY NOTE: Promulgated in accordance with R.S. 40:4(A)(7) and R.S. 40:5(2)(3)(7)(9)(16)(17)(20).

HISTORICAL NOTE: Promulgated by the Department of Health and Hospitals, Office of Public Health, LR 38:2894 (November 2012).

### **§1511. Materials**

A. Unless otherwise provided for in this Chapter, all piping fixtures or devices used in the installation of drainage and water distribution systems for travel trailer parks, or

parts thereof, shall conform to the quality and weights of materials required by the *Louisiana State Plumbing Code*.

AUTHORITY NOTE: Promulgated in accordance with R.S. 40:4(A)(7) and R.S. 40:5(2)(3)(7)(9)(16)(17)(20).

HISTORICAL NOTE: Promulgated by the Department of Health and Hospitals, Office of Public Health, LR 38:2894 (November 2012).

### §1513. General Regulations

A. Unless otherwise provided for in this Chapter, all plumbing fixtures, piping drains, appurtenances and appliances designed and used in a park drainage, water distribution system and service connections shall be installed in conformance with the Louisiana State Plumbing Code.

AUTHORITY NOTE: Promulgated in accordance with R.S. 40:4(A)(7) and R.S. 40:5(2)(3)(7)(9)(16)(17)(20).

HISTORICAL NOTE: Promulgated by the Department of Health and Hospitals, Office of Public Health, LR 38:2894 (November 2012).

### §1515. Park Drainage System

A. The sewer main and sewer laterals shall be installed in a separate trench not less than 5 feet (1524 mm) from the park water service or distribution system (see §§613.C and 613.D of this code).

B. The minimum size of pipe in any travel trailer park drainage system shall be 4 inches.

C. Each travel trailer shall be considered as 6 fixture units in determining discharge requirements in the design of park drainage and sewage disposal systems.

D. Minimum *grade*<sub>(S)</sub> for sewers shall be so designed that the flow will have a mean velocity of 2 fps (0.6096 m/s) when the pipe is flowing half full.

E. The discharge of a park drainage system shall be connected to a community sewerage system. Where a community sewerage system is not available, an approved commercial treatment facility or individual sewerage system shall be installed in accord with the requirements of LAC 51:XIII (Sewage Disposal).

F. Manholes and/or cleanouts shall be provided and constructed as required in Chapter 7 of this code. Manholes and/or cleanouts shall be accessible and brought to *grade*<sub>(G)</sub>.

G. When in a travel trailer park (i.e., other than a single travel trailer on its own lot), the sewer main shall be provided with a minimum 4-inch vent, not more than 5 feet (1524 mm) downstream from its upper trap. Long mains shall be provided with additional relief vents at intervals of not more than 200 feet (61 m) thereafter. These relief vents shall be a minimum of 4 inches and shall be securely supported and extended a minimum of 10 feet (3048 mm) above *grade*<sub>(G)</sub>.

H. Branch lines or sewer laterals to individual travel trailers shall be not less than 4-inch diameter.

I. Sewer inlets shall be 4-inch diameter and extend above *grade*<sub>(G)</sub> 3 to 6 inches (76 to 152 mm). Each inlet shall

be provided with a gas-tight seal when connected to a trailer and have a gas-tight seal plug for use when not in service.

J. Each trailer site shall be provided with a trailer trap. Sewer laterals over 30 ft (9144 mm) from the main park drainage sewer shall be provided with an individual vent and shall also be provided with a 4-inch cleanout brought to *grade*<sub>(G)</sub>. When an individual vent for the sewer lateral/trailer trap is required, it shall be 3-inch minimum (upstream of the clean out fitting) and shall extend not less than 10 inches above the roof of the travel trailer.

K. To provide the shortest possible drain connection between the travel trailer outlet and sewer inlet, all sewer inlets should terminate with reference to the site location of the travel trailer.

L. Drain connections shall slope continuously downward and form no traps. All pipe joints and connections shall be installed and maintained gastight and watertight.

M. No sewage, waste water, or any other effluent shall be allowed to be deposited on the surface of the ground.

N. Testing the Park Drainage System. Upon completion and before covering, the park drainage system shall be subjected to a static water test performed in accordance with §§319.A and 319.B.1 of this code.

AUTHORITY NOTE: Promulgated in accordance with R.S. 40:4(A)(7) and R.S. 40:5(2)(3)(7)(9)(16)(17)(20).

HISTORICAL NOTE: Promulgated by the Department of Health and Hospitals, Office of Public Health, LR 38:2894 (November 2012).

### §1517. Water Distribution System

A. General. Every travel trailer site shall be provided with an individual branch water service line delivering potable water. The outlet of the branch water service line shall terminate on the left side of the site of the travel trailer.

B. Minimum Size. Water service lines to each trailer site shall be sized to provide a minimum of 8 gpm (0.505 L/s) at the point of connection with the trailer's water distribution system. All water service lines shall be a minimum of  $\frac{3}{4}$  inch.

C. Backflow. A minimum of a double check valve assembly backflow preventer shall be installed on the water service line to each independent trailer at, or near, the trailer's water service connection. Backflow preventer devices shall meet the requirements of §609.B and Table 609 of this code. Check valves shall be designed and maintained to close drip tight at a reduced pressure of not less than 1 nor more than 5 psi (6.9 to 34.5 kPa). Check valves must be identified with the manufacturer's name and model number.

D. Separate Service Shutoff. A separate service shutoff valve shall be installed in each water service line on the supply side of the backflow preventer device. Per §617.A of this code, such separate shutoff valve shall be a full port ball valve.

E. Water Service Connections. The water service connection from the water service line to the trailer shall be



not less than 1/2-inch diameter. A rigid pipe shall not be used. Flexible metal tubing is permitted. Fittings at either end shall be of a quick disconnect type not requiring any special tools or knowledge to install or remove.

AUTHORITY NOTE: Promulgated in accordance with R.S. 40:4(A)(7) and R.S. 40:5(2)(3)(7)(9)(16)(17)(20).

HISTORICAL NOTE: Promulgated by the Department of Health and Hospitals, Office of Public Health, LR 38:2895 (November 2012).

**§1519. Travel Trailer Connections**

A. Responsibility. When it is evident that there exists, or may exist, a violation of these rules, the owner, operator, lessee, person in charge of the park, or any other person causing a violation shall cause it to be corrected immediately or disconnect the service connection and travel trailer drain connection from the respective park water service line and sewer lateral.

B. Drain Connections. Travel trailer drain connections shall be of approved semi rigid or flexible reinforced hose having smooth interior surfaces of not less than 3-inch inside diameter. Drain connections shall be equipped with a standard quick disconnect screw or clamp type fitting, not less in size than the outlet. Drain connections shall be

gastight and no longer than necessary to make the connection between the travel trailer outlet and the trap inlet on the site.

AUTHORITY NOTE: Promulgated in accordance with R.S. 40:4(A)(7) and R.S. 40:5(2), (3), (7), (9), (16), (17), and (20).

HISTORICAL NOTE: Promulgated by the Department of Health and Hospitals, Office of Public Health, LR 38:2895 (November 2012).

**§1521. Maintenance**

A. All devices or safeguards required by this Chapter shall be maintained in good working order by the owner, operator, or lessee of the travel trailer park or his designated agent.

AUTHORITY NOTE: Promulgated in accordance with R.S. 40:4(A)(7) and R.S. 40:5(2)(3)(7)(9)(16)(17)(20).

HISTORICAL NOTE: Promulgated by the Department of Health and Hospitals, Office of Public Health, LR 38:2895 (November 2012).

**§1523. Individual Travel Trailers**

A. Individual travel trailers located within previously constructed travel trailer parks shall be provided with a trailer trap in accord with §1003.E of this code.

APPROVED MATERIALS FOR TRAP & VENT:

- (1) CAST IRON PIPE & FITTINGS.
- (2) ABS OR PLASTIC PIPE & FITTINGS (SCH. 40)

APPROVED SEWER PIPES:

- (1) CAST IRON SEWER PIPE.
  - (2) VITRIFIED CLAY SEWER PIPE.
  - (3) APPROVED PLASTIC PIPE AND FITTINGS (MIN. SDR 35)
- (NOTE: FROM A POINT AT LEAST 3 FEET OUTSIDE THE EDGE OF THE TRAILER TO THE SEWAGE SYSTEM.)

- NOTES: (1) ASTM D2729 IS NOT APPROVED FOR ANY PART OF THE SYSTEM.  
 (2) INSTALL 4" CLEANOUT FOR TRAILER CONNECTION AND TERMINATE 3 TO 6 INCHES ABOVE GRADE.  
 (3) INSTALL 3" MALE ADAPTER IN TRAILER CONNECTION.

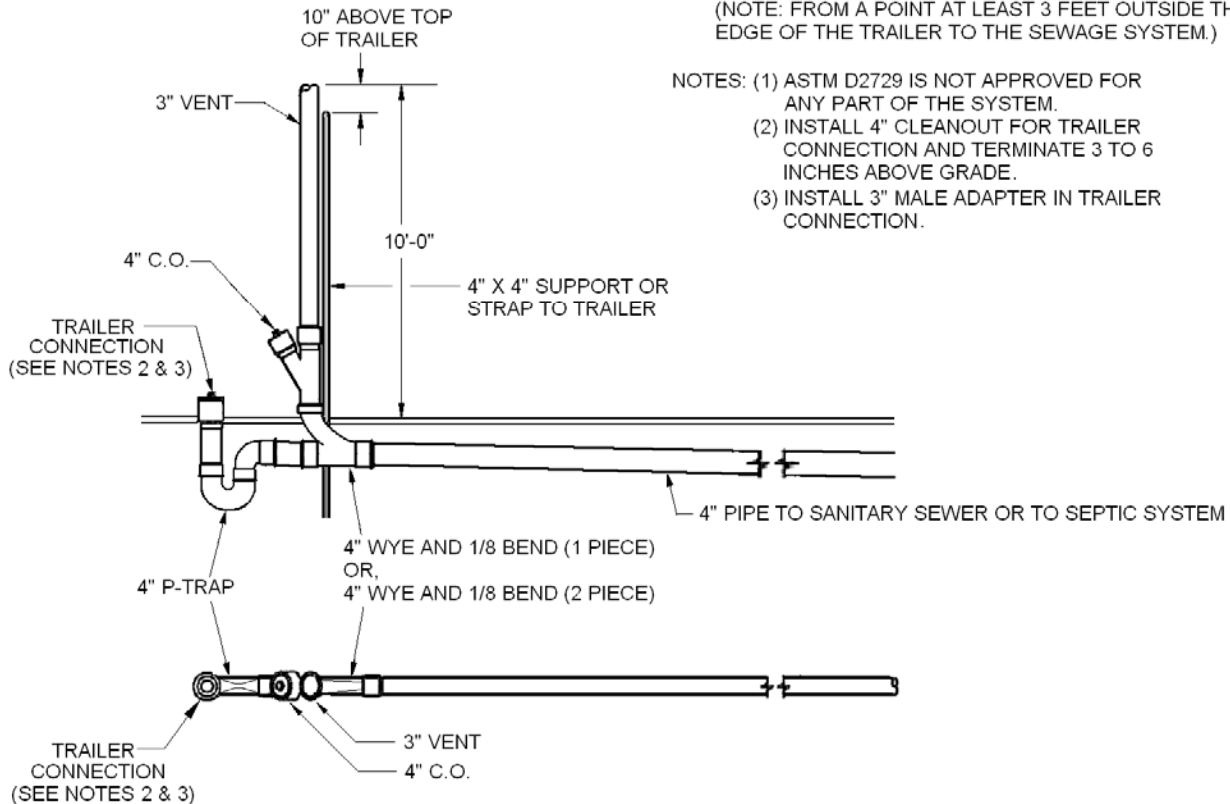


Figure 1523.A—Trailer Trap and Vent

AUTHORITY NOTE: Promulgated in accordance with R.S. 40:4(A)(7) and R.S. 40:5(2)(3)(7)(9)(16)(17)(20).

HISTORICAL NOTE: Promulgated by the Department of Health and Hospitals, Office of Public Health, LR 38:2895 (November 2012).

## **Chapter 16. Mobile/Manufactured Homes and Mobile/Manufactured Home Parks [formerly Appendix C—Mobile/ Manufactured Homes and Mobile/Manufactured Home Parks]**

### **§1601. Purpose, Application and Scope**

A. With the exception of §1623 of this code, the requirements set forth in this Chapter shall apply specifically to all new mobile/manufactured home parks, and to additions to existing parks as herein defined, and are to provide minimum standards for sanitation and plumbing installation within these parks, for the accommodation, use and parking of mobile/manufactured homes. Plumbing installations within mobile/manufactured homes shall be installed in accordance with NFPA 1192.

AUTHORITY NOTE: Promulgated in accordance with R.S. 40:4(A)(7) and R.S. 40:5(2)(3)(7)(9)(16)(17)(20).

HISTORICAL NOTE: Promulgated by the Department of Health and Hospitals, Office of Public Health, LR 38:2896 (November 2012).

### **§1603. Definitions**

A. Definitions contained in Chapter 2 and Section 1503 of this code shall also apply to this Chapter, except where the following special definition shall apply.

*Mobile/Manufactured Home*—a vehicular, portable structure built on a chassis and designed to be used as a dwelling without a permanent foundation when connected to indicated utilities per NFPA 1192.

AUTHORITY NOTE: Promulgated in accordance with R.S. 40:4(A)(7) and R.S. 40:5(2)(3)(7)(9)(16)(17)(20).

HISTORICAL NOTE: Promulgated by the Department of Health and Hospitals, Office of Public Health, LR 38:2896 (November 2012).

### **§1605. General Regulations**

A. Other general provisions of this code shall govern the installation of plumbing systems in mobile/manufactured home parks, except where special conditions or construction are specifically defined in this Chapter.

B. Mobile/manufactured homes shall not hereafter be parked in any mobile/manufactured home park unless plumbing and sanitation facilities have been installed and maintained in conformity with these regulations. Every mobile/manufactured home shall provide a gastight and watertight connection for sewage disposal which shall be connected to an underground sewage collection system

discharging into a community sewerage system, a commercial treatment facility, or an individual sewerage system which has been approved by the state health officer.

AUTHORITY NOTE: Promulgated in accordance with R.S. 40:4(A)(7) and R.S. 40:5(2)(3)(7)(9)(16)(17)(20).

HISTORICAL NOTE: Promulgated by the Department of Health and Hospitals, Office of Public Health, LR 38:2896 (November 2012).

### **§1607. Plans and Specifications**

A. The owner or operator of every mobile/manufactured home park, or the plumbing contractor employed by him before providing areas of space for the use and accommodation of mobile/manufactured homes, shall make application for a permit (where such permit is required by state, parish, city or other local laws or ordinances) or regardless of whether or not an actual permit is required, shall file two sets of plans and specifications with the department(s) having jurisdiction for their review and approval. The plans and specifications shall be in detail and shall include/comply with the following:

1. a scaled plot plan of the park, indicating the spaces, area or portion of the park for the parking of mobile/manufactured homes;
2. size, location and specification of park drainage system;
3. size, location and specification of water supply lines;
4. size, location and layout of service building, if applicable (see §1619 of this code);
5. size, location, specification and layout of the fire protection system, if applicable;
6. a scaled layout of typical mobile/manufactured home sites;
7. applications/submittals shall bear the approval of the local enforcement agencies as to compliance with city or parish plumbing, zoning and health ordinances;
8. plumbing required by this Chapter shall comply with all city, parish and state plumbing and health ordinances and regulations;
9. the issuance of a permit (or an approval of a submittal) shall not constitute approval of any violation of this code or violation of any city or parish ordinance or regulation; and
10. an approved set of plans and specifications and a copy of the permit (or written approval of a submittal) shall be kept on the park premises until the final inspection has been made.

AUTHORITY NOTE: Promulgated in accordance with R.S. 40:4(A)(7) and R.S. 40:5(2)(3)(7)(9)(16)(17)(20).

HISTORICAL NOTE: Promulgated by the Department of Health and Hospitals, Office of Public Health, LR 38:2897 (November 2012).

#### **§1609. Materials**

A. Unless otherwise provided for in this Chapter, all piping fixtures or devices used in the installation of drainage and water distribution systems for mobile/manufactured home parks, or parts thereof, shall conform to the quality and weights of materials required by the Louisiana State Plumbing Code.

AUTHORITY NOTE: Promulgated in accordance with R.S. 40:4(A)(7) and R.S. 40:5(2)(3)(7)(9)(16)(17)(20).

HISTORICAL NOTE: Promulgated by the Department of Health and Hospitals, Office of Public Health, LR 38:2897 (November 2012).

#### **§1611. General Regulations**

A. Unless otherwise provided for in this Chapter, all plumbing fixtures, piping, drains, appurtenances and appliances designed and used in a park drainage, water distribution system and service connections shall be installed in conformance with the Louisiana State Plumbing Code.

AUTHORITY NOTE: Promulgated in accordance with R.S. 40:4(A)(7) and R.S. 40:5(2)(3)(7)(9)(16)(17)(20).

HISTORICAL NOTE: Promulgated by the Department of Health and Hospitals, Office of Public Health, LR 38:2897 (November 2012).

#### **§1613. Park Drainage System**

A. The sewer main and sewer laterals shall be installed in a separate trench not less than 5 feet (1524 mm) from the park water service or distribution system. See §§613.C and 613.D of this code.

B. The minimum size of pipe in any mobile/manufactured home park drainage system shall be 4 inches.

C. Each mobile/manufactured home shall be considered as 15 fixture units in determining discharge requirements in the design of park drainage and sewage disposal systems.

D. Minimum grade<sub>(S)</sub> for sewers shall be so designed that the flow will have a mean velocity of 2 fps (0.6096 m/s) when the pipe is flowing half full.

E. The discharge of a park drainage system shall be connected to a community sewerage system. Where a community sewerage system is not available, an approved commercial treatment facility or an individual sewerage system shall be installed in accord with the requirements of LAC 51:XIII (Sewage Disposal).

F. Manholes and/or cleanouts shall be provided and constructed as required in Chapter 7 of this code. Manholes and/or cleanouts shall be accessible and brought to grade<sub>(G)</sub>.

G. When located in a mobile/manufactured home park (i.e., other than a single mobile/manufactured home on its own lot), the sewer main shall be provided with a minimum 4-inch vent, not more than 5 feet (1524 mm) downstream from its upper trap. Long mains shall be provided with additional relief vents at intervals of not more than 200 feet

(61 m) thereafter. These relief vents shall be a minimum of 4 inches and shall be securely supported and extended a minimum of 10 feet (3048 mm) above grade<sub>(G)</sub>.

H. Branch lines or sewer laterals to mobile/manufactured homes shall be not less than 4-inch diameter.

I. Sewer inlets shall be 4-inch diameter and extend above grade<sub>(G)</sub> 3 to 6 inches (76 to 152 mm). Each inlet shall be provided with a gastight seal when connected to a mobile/manufactured home and have a gastight seal plug for use when not in service.

J. Each mobile/manufactured home site shall be provided with a trailer trap. Sewer laterals over 30 ft (9144 mm) from the main park drainage sewer shall be provided with an individual vent and shall also be provided with a 4-inch cleanout brought to grade<sub>(G)</sub>. When an individual vent for the sewer lateral/trailer trap is required, it shall be 3-inch minimum (upstream of the clean out fitting) and shall extend not less than 10 inches above the roof of the mobile/manufactured home.

K. To provide the shortest possible drain connection between the mobile/manufactured home outlet and sewer inlet, all sewer inlets should terminate in the rear one-third of the mobile/manufactured home as placed on the site.

L. Drain connections shall slope continuously downward and form no traps. All pipe joints and connections shall be installed and maintained gastight and watertight.

M. No sewage, waste water, or any other effluent shall be allowed to be deposited on the surface of the ground.

N. Testing the Park Drainage System. Upon completion and before covering, the park drainage system shall be subjected to a static water test performed in accordance with §§319.A and 319.B.1 of this code.

AUTHORITY NOTE: Promulgated in accordance with R.S. 40:4(A)(7) and R.S. 40:5(2)(3)(7)(9)(16)(17)(20).

HISTORICAL NOTE: Promulgated by the Department of Health and Hospitals, Office of Public Health, LR 38:2897 (November 2012).

#### **§1615. Water Supply and Distribution Systems**

A. General. Every mobile/manufactured home site shall be provided with an individual branch water service line delivering potable water. The outlet of the branch water service line shall terminate on the left side of the site of the mobile/manufactured home.

B. Minimum Size. Water service lines to each mobile/manufactured home site shall be sized to provide a minimum of 17 gpm (1.1 L/s) at the point of connection with the mobile/manufactured home's water distribution system. All water service lines shall be a minimum of 3/4-inch.

C. Separate Service Shutoff. A separate service shutoff valve shall be installed in each water service line. Per §617.A of this code, such separate shutoff valve shall be a full port ball valve.

D. Water Service Connections. The water service connection from the water service line to the

mobile/manufactured home shall be not less than 1/2-inch diameter. A rigid pipe shall not be used. Flexible metal tubing is permitted. Fittings at either end shall be of a quick disconnect type not requiring any special tools or knowledge to install or remove.

E. Water Supply System Design. The water supply system shall be designed to provide a minimum of 150 gallons (568 L) per day for each mobile/manufactured home, plus such additional volume as may be required for fire protection of the park, service buildings and other community facilities.

AUTHORITY NOTE: Promulgated in accordance with R.S. 40:4(A)(7) and R.S. 40:5(2)(3)(7)(9)(16)(17)(20).

HISTORICAL NOTE: Promulgated by the Department of Health and Hospitals, Office of Public Health, LR 38:2898 (November 2012).

#### **§1617. Mobile/Manufactured Home Connections**

A. Responsibility. When it is evident that there exists, or may exist, a violation of these rules, the owner, operator, lessee, person in charge of the park or any other person causing a violation shall cause it to be corrected immediately or disconnect the service connections and mobile/manufactured home drain connection from the respective park water service line and sewer lateral.

B. Drain Connections. Mobile/manufactured home drain connections shall be of approved semi-rigid pipe having smooth interior surfaces of not less than 3-inch inside diameter. Drain connections shall be equipped with a standard quick disconnect screw, clamp type fitting or solvent welder, not less in size than the outlet. Drain connections shall be gastight and no longer than necessary to make the connection between the mobile/manufactured home outlet and the trap inlet on the site.

AUTHORITY NOTE: Promulgated in accordance with R.S. 40:4(A)(7) and R.S. 40:5(2)(3)(7)(9)(16)(17)(20).

HISTORICAL NOTE: Promulgated by the Department of Health and Hospitals, Office of Public Health, LR 38:2898 (November 2012).

#### **§1619. Service Buildings**

A. Each mobile/manufactured home park serving travel trailers shall have at least one service building to provide minimum sanitation and laundry facilities in accord with §1509 of this code.

AUTHORITY NOTE: Promulgated in accordance with R.S. 40:4(A)(7) and R.S. 40:5(2)(3)(7)(9)(16)(17)(20).

HISTORICAL NOTE: Promulgated by the Department of Health and Hospitals, Office of Public Health, LR 38:2898 (November 2012).

#### **§1621. Maintenance**

A. All devices or safeguards required by this Chapter shall be maintained in good working order by the owner, operator, or lessee of the mobile/manufactured home park or his designated agent.

AUTHORITY NOTE: Promulgated in accordance with R.S. 40:4(A)(7) and R.S. 40:5(2)(3)(7)(9)(16)(17)(20).

HISTORICAL NOTE: Promulgated by the Department of Health and Hospitals, Office of Public Health, LR 38:2898 (November 2012).

#### **§1623. Individual Mobile/Manufactured Homes**

A. Individual mobile/manufactured homes located within previously constructed mobile/manufactured home parks shall be provided with a trailer trap in accord with §1003.E of this code.

- APPROVED MATERIALS FOR TRAP & VENT:  
 (1) CAST IRON PIPE & FITTINGS.  
 (2) ABS OR PLASTIC PIPE & FITTINGS (SCH. 40)

- APPROVED SEWER PIPES:  
 (1) CAST IRON SEWER PIPE.  
 (2) VITRIFIED CLAY SEWER PIPE.  
 (3) APPROVED PLASTIC PIPE AND FITTINGS (MIN. SDR 35)  
 (NOTE: FROM A POINT AT LEAST 3 FEET OUTSIDE THE EDGE OF THE TRAILER TO THE SEWAGE SYSTEM.)

- NOTES: (1) ASTM D2729 IS NOT APPROVED FOR ANY PART OF THE SYSTEM.  
 (2) INSTALL 4" CLEANOUT FOR TRAILER CONNECTION AND TERMINATE 3 TO 6 INCHES ABOVE GRADE.  
 (3) INSTALL 3" MALE ADAPTER IN TRAILER CONNECTION.

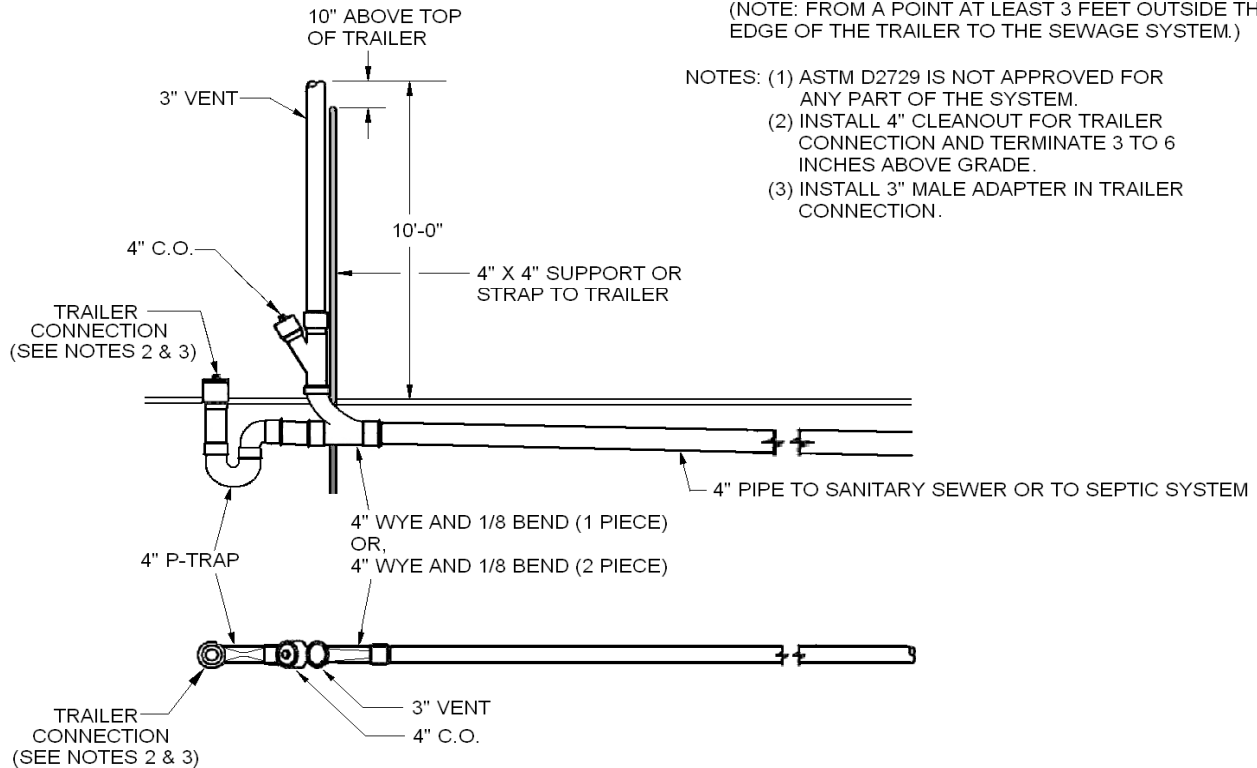


Figure 1623.A—Trailer Trap and Vent

AUTHORITY NOTE: Promulgated in accordance with R.S. 40:4(A)(7) and R.S. 40:5(2)(3)(7)(9)(16)(17)(20).

HISTORICAL NOTE: Promulgated by the Department of Health and Hospitals, Office of Public Health, LR 38:2898 (November 2012).

## Chapter 17. Sewerage System Regulations [formerly Appendix E—Private Sewage Disposal]

### §1701. General

A. Refer to Part XIII (Sewage Disposal) of the State of Louisiana Sanitary Code (LAC 51:XIII) for applicable sewage disposal regulations.

AUTHORITY NOTE: Promulgated in accordance with R.S. 40:4(A)(7) and R.S. 40:5(2)(3)(7)(9)(16)(17)(20).

HISTORICAL NOTE: Promulgated by the Department of Health and Hospitals, Office of Public Health, LR 38:2899 (November 2012).

## Chapter 18. Appendices

### §1801. Scope

A. The provisions of the appendices contained in this Chapter are designed for informational purposes only. When the word "shall" is used in one or more provisions of this Chapter, it is advisable to take the provision seriously and as though it were an actual requirement. Doing so will assist in ensuring compliance with the actual requirements of Chapters 1-17.

AUTHORITY NOTE: Promulgated in accordance with R.S. 40:4(A)(7) and R.S. 40:5(2)(3)(7)(9)(16)(17)(20).

HISTORICAL NOTE: Promulgated by the Department of Health and Hospitals, Office of Public Health, LR 38:2899 (November 2012).

### §1803. Appendix A—Roof Drain Sizing Method

A. Sizing Example. The following example gives one method of sizing the primary drain system and sizing the scuppers in the parapet walls. This method converts the roof area to an equivalent roof area for a 4-inch rate of rainfall so that Tables 1111.A and 1111.B of this code can be used as printed. The method described in §1111.B.2 of this code converts Tables 1111.A and 1111.B of this part to tables for the rate of rainfall specified for the area.

1. Problem: Given the roof plan in Figure 1803.A.1 of this Part and the site location in Birmingham, Alabama, size the primary roof drain system and size the scuppers, denoting the required head of water above the scupper for the structural engineer.

NOTE: For the purposes of this appendix the following metric conversions are applicable:

- 1 in = 25.4 mm
- 1 ft = 305 mm
- 1 ft<sup>2</sup> = 0.0929 m<sup>2</sup>

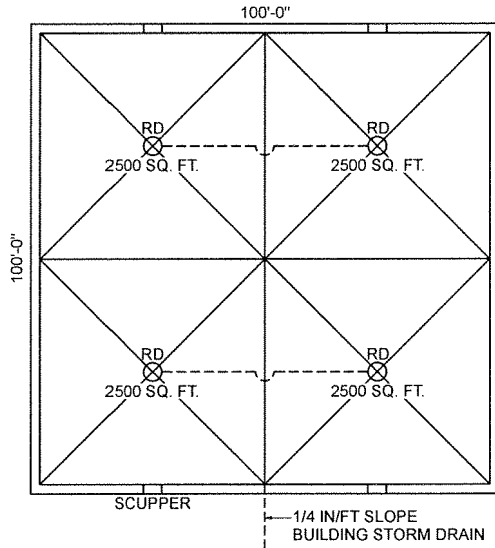


Figure 1803.A.1—Example Roof Plan

2. Solution:

Step a. From Figure 1111.E of this Part, the 100 year 60 minute precipitation is 3.75 inches per hour.

Step b. Each vertical drain must carry 2,500 sq ft of roof area at 3.75 inches per hour of rainfall. To convert to an area for a 4 inch per hour rainfall to enter LAC 51:XIV.Table 1111.A do this:

$$2,500 \div 4 \times 3.75 = 2,344 \text{ sq ft.}$$

Enter LAC 51:XIV.Table 1111.A until you find a diameter pipe that will carry 2,344 sq ft. A minimum 4-inch vertical drain is required.

Step c. Horizontal Drain  
2,500 sq ft.

To convert to an area for use in LAC 51:XIV.Table 1111.B do this:

$$2,500 \div 4 \times 3.75 = 2,344 \text{ sq ft}$$

Enter LAC 51:XIV.Table 1111.B until you find a diameter pipe that will carry 2,344 sq ft.

A minimum 4-inch diameter pipe with a 1/4 inch per foot slope will carry 2,650 sq ft. A minimum 4-inch diameter drain on a 1/4 inch per foot slope is required.

Step d. Horizontal Drain  
5,000 sq ft.

To convert to an area for use in LAC 51:XIV.Table 1111.B do this:

$$5,000 \div 4 \times 3.75 = 4,688 \text{ sq ft.}$$

Enter LAC 51:XIV.Table 1111.B until you find a diameter pipe that will carry 4,688 sq ft. A 5-inch diameter pipe with a 1/4 inch per foot slope will

carry 4,720 sq ft. A minimum 5-inch diameter drain on a 1/4 inch per foot slope is required.

Step e. Horizontal Drain  
10,000 sq ft.

To convert to an area for use in LAC 51:XIV.Table 1111.B do this:

$$10,000 \div 4 \times 3.75 = 9,375 \text{ sq ft.}$$

Enter LAC 51:XIV.Table 1111.B until you find a diameter pipe that will carry 9,375 sq ft. An 8-inch diameter pipe on 1/4 inch per foot slope will carry 16,300 sq ft but a 6-inch will carry only 7,550 sq ft; therefore, use an 8-inch diameter drain on a 1/4 inch per foot slope.

Step f. From Figure 1113.C of this Part, the rate caused by a 100 year 15 minute precipitation is 7.2 inches per hour. The scuppers must be sized to carry the flow caused by a rain fall rate of 7.2 inches per hour.

Step g. Each scupper is draining 2,500 sq ft of roof area. To convert this roof area to an area for use with LAC 51:XIV.Table 1803.A.2 do this:

$$2,500 \div 4 \times 7.2 = 9,375 \text{ sq ft} = 4,500 \text{ sq ft.}$$

Enter LAC 51:XIV.Table 1803.A.2 to find a length and head that will carry 4,500 sq ft or more. From LAC 51:XIV.Table 1803.A.2 a 12-inch wide weir with a 4-inch head carries 6,460 sq ft. Use 12-inch wide x 5-inch high scuppers at four locations. A height of 5 inches is needed to assure an open area above the 4-inch head.

Step h. Notify the structural engineer that the design of the roof structure must account for a height of water to the scupper entrance elevation plus 4 inches for the required head to cause design flow.

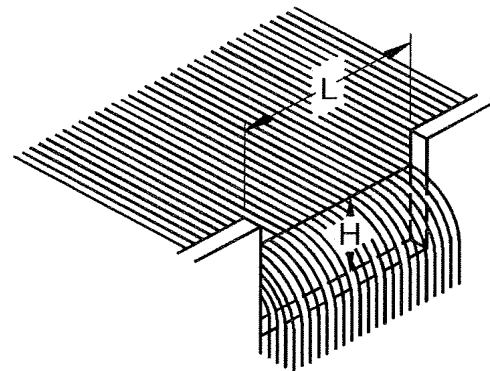


Figure 1803.A.2—Example Scupper

Table 1803.A.2 Scupper Sizing Table Roof Area (Sq ft)							
Head (H) Inches	Length (L) of Weir (Inches)						
	4	6	8	12	16	20	24
1	273	418	562	851	1,139	1,427	1,715
2	734	1,141	1,549	2,365	3,180	3,996	4,813
3	1,274	2,023	2,772	4,270	5,768	7,267	8,766
4	1,845	2,999	4,152	6,460	8,766	11,073	13,381
6	2,966	5,087	7,204	11,442	15,680	19,918	24,160

NOTE: Based on rainfall of 4 inches per hour

AUTHORITY NOTE: Promulgated in accordance with R.S. 40:4(A)(7) and R.S. 40:5(2)(3)(7)(9)(16)(17)(20).

HISTORICAL NOTE: Promulgated by the Department of Health and Hospitals, Office of Public Health, LR 38:2899 (November 2012).

## **§1805. Appendix B—Sizing of Water Piping System [formerly Appendix F—Sizing of Water Piping System]**

A. Scope. This Appendix outlines a procedure for sizing a water piping system. This design procedure is based on the minimum static pressure available from the supply source, the head charges in the system due to friction and elevation, and the rates of flow necessary for operation of various fixtures.

1. Because of the variable conditions encountered in hydraulic design, it is impractical to specify definite and detailed rules for sizing of the water piping system. Accordingly, other sizing or design methods conforming to good engineering practice standards are acceptable alternates to that presented herein.

B. Information Required. Prior to beginning calculations, the following preliminary information shall be measured or otherwise obtained from the water supplier.

1. Static Water Service Pressure/Meter Friction Loss. The minimum daily static water service pressure in the area where the building is to be located shall be measured or otherwise obtained from the water supplier. If the building's water supply is to be metered, obtain information regarding friction loss relative to the rate of flow for meters in the range of sizes likely to be used. Friction loss data can be obtained from most manufacturers of water meters.

C. Estimate of Demand Load Required. Prior to beginning calculations, the following estimates shall be made.

1. Fixture Water Supply Demand. Estimate the water supply demand of the building main and the principal branches and risers of the water distribution system by totaling the corresponding demand for fixtures from the applicable part of Table 1805.C of this code. The Load (in water supply fixture units) listed in Column 1 of Table 1805.C of this code shall be calculated using the load values, in water supply fixture units, obtained from Table 1805.B of this code.

2. Continuous Water Supply Demand. Estimate continuous water supply demands in gallons per minute for lawn sprinklers, air conditioners, etc., and add the sum to the total water supply demand for fixtures. The result is the estimated total water supply demand for the building.

D. Selection of Pipe Size. The selection of the size for the water service pipe, water riser pipes, branch supply lines, etc., shall be calculated using the following procedures.

1. General. Decide the desirable minimum residual pressure that should be maintained at the highest fixture in the water distribution system. If the highest group of fixtures contains flush valves, the pressure for the group should be not less than 15 psi (103.4 kPa) flowing. For flush tank supplies, the available pressure may not be less than 8 psi (55.2 kPa) flowing, except blowout action fixtures may not be less than 25 psi (172.4 kPa) flowing.

2. Pipe Sizing. Pipe sizes may be selected according to the following procedure, except that the sizes selected shall be not less than the minimum required by the Louisiana State Plumbing Code.

a. This water pipe sizing procedure is based on a system of pressure requirements and losses, the sum of which must not exceed the minimum pressure available at the supply source. These pressures are as follows.

i. Pressure required at fixture to produce required flow (see §§611.C, 611.D, and 611.E of this code).

ii. Static pressure loss or gain (due to head) is computed at 0.433 psi per foot (9.8 kPa/m) of elevation change.

(a). Example. Assume that the highest fixture supply outlet is 20 ft (6.1 m) above or below the supply source. This produces a static pressure differential of 20 ft x 0.433 psi/ft (6.1 m x 9.8 kPa/m) which equates to an 8.66 psi (59.8 kPa) loss or an 8.66 psi (59.8 kPa) gain.

iii. Loss through water meter. The friction or pressure loss can be obtained from meter manufacturers.

iv. Loss through taps in water main (see Table 1805.D of this code).

v. Losses through special devices such as filters, softeners, backflow preventers, and pressure regulators. These values must be obtained from the manufacturers.

vi. Loss through valves and fittings (see Tables 1805.E and 1805.F of this code). Losses for these items are calculated by converting to equivalent length of piping and adding to the total pipe length.

vii. Loss due to pipe friction can be calculated when the pipe size, the pipe length and the flow through the pipe are known. With these three items, the friction loss can be determined using Figures 1805.A.1-1805.D of this Part. When using charts, use pipe inside diameter. For piping flow charts not included, use manufacturers' tables and velocity recommendations.

3. Example. The following example is provided to assist one in calculating the proper sizing of the water piping system for a plumbing installation of a building or other structure.

NOTE: For the purposes of this example the following metric conversions are applicable:

1 cfm = 0.4719 L/s	1 ft <sup>2</sup> = 0.0929 m <sup>2</sup>
1 degree = 0.0175rad	1 psi = 6.895 kPa
1 in = 25.4 mm	1 gpm = 0.0631 L/s

a. Problem. What size copper water pipe, service and distribution will be required to serve a two story factory building having on each floor, back-to-back, two toilet rooms each equipped with hot and cold water? The highest fixture is 21 feet above the street main which is tapped with a 2-inch corporation cock at which point the minimum pressure is 55 psi. In the building basement a 2-inch meter and 3-inch reduced pressure zone backflow preventer with a maximum pressure drop of 9 psi are to be installed. The system is shown by the example diagram (Figure 1805.D.3 of this code). To be determined are the pipe sizes for the service main and the cold and hot water distribution pipes.

PUBLIC HEALTH—SANITARY CODE

b. Solution. A tabular arrangement such as shown in Table 1805.A of this code should first be constructed. The steps to be followed in solving the problem are indicated by the tabular arrangement itself as they are in sequence, Columns 1-10 and Lines a-l.

i. Step i. Perform the following:

(a). Column 1. Divide the system into sections breaking at major changes in elevation or where branches lead to fixture groups. After point B (see Figure 1805.D.3 of this code) separate consideration will be given to the hot and cold water piping. Enter the sections to be considered in the service and cold water piping in Column 1 of the tabular arrangement.

(b). Column 3. According to the method given in §1805.C of this code, determine the gpm of flow to be expected in each section of the system. These flows range from 28.6 to 108 gpm.

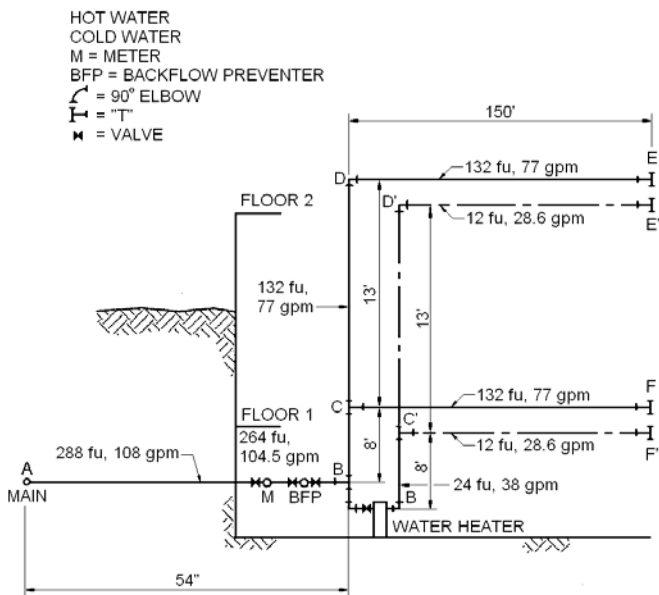


Figure 1805.D.3—Sizing Example

ii. Step ii. Perform the following.

(a). Line "a." Enter the minimum pressure available at the main source of supply in Column 2. This is 55 psi.

(b). Line "b." Determine from §611.E of this code the highest pressure required for the fixtures on system, which is 15 psi, to operate a flushometer valve.

(c). Line "c." Determine the pressure loss for the meter size given or assumed. The total water flow from the main through the service as determined in Step i (above) will serve to aid in the meter selected.

(d). Line "d." Select from Table 1805.D of this code and enter the pressure loss for the tap size given or assumed.

(e). Line "e." Determine the difference in elevation between the main or source of

supply and the highest fixture on the system and multiply this figure, expressed in feet, by 0.433 psi. Enter the resulting psi product on Line "e."

(f). Lines "f," "g," "h." The pressure losses through filters, backflow preventers or other special fixtures must be obtained from the manufacturer or estimated and entered on these lines.

iii. Step iii, Line "i." The sum of (Lines "b" through "h") the pressure requirements and losses which affect the overall system is entered on this line.

iv. Step iv, Line "j." Subtract Line "i" from Line "a." This gives the pressure which remains available from overcoming friction losses in the system. This figure is a guide to the pipe size which is chosen for each section, as the total friction losses through the longest run of pipe.

(a). Exception. When the main is above the highest fixture, the resulting psi must be considered a pressure gain (static head gain) and omitted from the sums of Lines "b"- "h" and added to Line "j."

v. Step v, Column 4. Enter the length of each section from the main to the end of the longest run (at Point E).

vi. Step vi, Column 5. Select a trial pipe size. A rule of thumb is that size will become progressively smaller as the system extends farther from the main source of supply. (Trial pipe size may be arrived at by the following formula:  $PSI=j \times 100/\text{total pipe length}$ )

EXAMPLE:  $PSI = 9.36 \times 100/225 = 4.16$

From main to most remote outlet—Check applicable graph for size for this PSI and GPM.

vii. Step vii, Column 6. Select from Tables 1805.E or 1805.F of this code the equivalent lengths for the trial pipe size of fittings and valves on the section. Enter the sum for each section in Column 6. (The number of fittings to be used in the installation of this piping must be an estimate.)

viii. Step viii. Column 7: Add the figures from Column 4 and Column 6, and enter in Column 7. Express the sum in 100s of feet.

ix. Step ix. Column 8: Select from the applicable figure (Figures 1805.A.1 through 1805.D of this Part) the friction loss per 100 feet of pipe for the gpm flow in a section (Column 3) and trial pipe size (Column 5).

x. Step x. Column 9: Multiply the figures in Columns 7 and 8 for each section and enter in Column 9.

xi. Step xi. Line k: Enter the sum of the values in Column 9. In summing, use only those values associated with the longest run (i.e., don't use the value associated with section CF unless the friction loss for CF by itself is greater than the combined fixture loss of  $AB + BC + CD + DE$ ).

xii. Step xii. Line 1: Subtract Line "k" from Line "j" and enter in Column 10.



(a). The result should always be a positive or plus figure. If it is not, it is necessary to repeat the operation utilizing Columns, 5, 6, 8 and 9 until a balance or near balance is obtained. If the difference between Lines "j" and "k" is positive and large, it is an indication that the pipe sizes are too large and may, therefore, be reduced thus saving materials. In such a case, the operations utilizing Columns 5, 6, 8 and 9 should again be repeated.

sections. Repeating this operation a second time using the same sketch but considering the demand for hot water, it is possible to size the hot water distribution piping. This has been worked up as a part of the overall problem in the tabular arrangement used for sizing the service and cold water distribution piping. It should be noted that consideration must be given the pressure losses from the street main to the water heater (section AB) in determining the hot water pipe sizes.

c. Answer: The final figures entered in Column 5 become the design pipe size for the respective

Table 1805.A Recommended Tabular Arrangement for Use in Solving Pipe Sizing Problems											
Column		1	2	3	4	5	6	7	8	9	10
Line		Description	Lbs. per square inch (psi)	Gal. per min. through section	Length of section (ft)	Trial pipe size (in)	Equivalent length of fittings and valves (ft)	Total equivalent length col.4 and col.6 (100 ft)	Friction loss per 100' of trial size pipe (psi)	Friction loss in equivalent length col.8 x col.7 (psi)	Excess pressure over friction losses (psi)
a	Service and cold water distribution piping (NOTE 1)	Minimum pressure available at main	55.00								
b		Highest pressure required at a fixture (§611.E of this code)	15.00								
c		Meter loss 2" meter	11.00								
d		Tap in main loss 2" tap (Table F103A of this code)	1.61								
e		Static head loss 21 x 0.43 psi	9.03								
f		Special fixture loss- backflow preventer	9.00								
g		Special fixture loss-Filter	0.00								
h		Special fixture loss-Other	0.00								
i		Total overall losses and requirements (sum of lines b-h)	45.64								
j		Pressure available to overcome pipe friction (line a minus lines b to h)	9.36								
	Designation pipe section (from diagram)	FU									
		AB	288	108.0	54	2 ½	12	0.66	3.6	2.38	
		BC	264	104.5	8	2 ½	2.5	0.105	3.2	0.34	
		CD	132	77.0	13	2 ½	8	0.21	1.9	0.40	
	Cold water distribution piping	CF (NOTE 2)	132	77.0	150	2 ½	12	1.62	1.9	3.08	
		DE	132	77.0	150	2 ½	14.5	1.645	1.9	3.12	
k	Total pipe friction losses (cold)									6.24	
l	Difference (line "j" minus line "k")							9.36	-6.24	=	3.12
	Pipe section (from diagram)	FU									
		AB'	288	108.0	54	2 ½	9.6	0.64	3.3	2.1	
		B'C'	24	38.0	8	2	9.0	0.17	1.4	0.24	
		C'D'	12	28.6	13	1 ½	5	0.18	3.2	0.58	
	Hot Water Distribution Piping	C'F' (NOTE 3)	12	28.6	150	1 ½	14	1.64	3.2	5.25	
		D'E'	12	28.6	150	1 ½	7	1.57	3.2	5.02	
k	Total pipe friction losses (hot)									7.94	
l	Difference (line "j" minus line "k")							9.36	-7.94	=	1.42

NOTES:

- To be considered as pressure gain for fixtures below main (consider separately omit from "i" and add to "j").

2. Consider separately, in Line "k" use CF 's Column 9 friction loss only if it is a greater friction loss than the sum of Column 9 friction losses of AB+BC+CD+DE.

Table 1805.B					
Load Values Assigned to Fixtures <sup>1</sup>					
Fixture	Occupancy	Type of Supply Control	Load Values, in Water Supply Fixture Units		
			Cold	Hot	Total
Bathroom group	Private	Flush tank	2.7	1.5	3.6
Bathroom group	Private	Flush valve	6.0	3.0	8.0
Bathtub	Private	Faucet	1.0	1.0	1.4
Bathtub	Public	Faucet	3.0	3.0	4.0
Bidet	Private	Faucet	1.5	1.5	2.0
Combination fixture	Private	Faucet	2.25	2.25	3.0
Dishwashing machine	Private	Automatic	-	1.4	1.4
Drinking fountain	Offices, etc.	3/8" valve	0.25	-	0.25
Kitchen sink	Private	Faucet	1.0	1.0	1.4
Kitchen sink	Hotel, Restaurant	Faucet	3.0	3.0	4.0
Laundry trays (1 to 3)	Private	Faucet	1.0	1.0	1.4
Lavatory	Private	Faucet	0.5	0.5	0.7
Lavatory	Public	Faucet	1.5	1.5	2.0
Service sink	Offices, etc.	Faucet	2.25	2.25	3.0
Shower head	Public	Mixing valve	3.0	3.0	4.0
Shower head	Private	Mixing valve	1.0	1.0	1.4
Urinal	Public	1" flush valve	10.0	-	10.0
Urinal	Public	3/4" flush valve	5.0	-	5.0
Urinal	Public	Flush tank	3.0	-	3.0
Washing machine (8 lbs.)	Private	Automatic	1.0	1.0	1.4
Washing machine (8 lbs.)	Public	Automatic	2.25	2.25	3.0
Washing machine (15 lbs.)	Public	Automatic	3.0	3.0	4.0
Water closet	Private	Flush valve	6.0	-	6.0
Water closet	Private	Flush tank	2.2	-	2.2
Water closet	Public	Flush valve	10.0	-	10.0
Water closet	Public	Flush tank	5.0	-	5.0
Water closet	Public or Private	FlushometerTank	2.0	-	2.0

NOTE:

1. For fixtures not listed, loads should be assumed by comparing the fixture to ones listed using water in similar quantities and at similar rates. The assigned loads for fixtures with both hot and cold water supplies are given for separate hot and cold water loads and for total load, the separate hot and cold water loads being three-fourths of the total load for the fixture in each case.

Table 1805.C					
Table for Estimating Demand					
Supply Systems Predominantly for Flush Tanks			Supply Systems Predominantly for Flush Valves		
Load	Demand		Load	Demand	
(Water Supply Fixture Units)	(Gallons per Minute)	(Cubic Feet per Minute)	(Water Supply Fixture Units)	(Gallons per Minute)	(Cubic Feet per Minute)
1	3.0	0.041104	-	-	-
2	5.0	0.0684	-	-	-
3	6.5	0.86892	-	-	-
4	8.0	1.06944	-	-	-
5	9.4	1.256592	5	15.0	2.0052
6	10.7	1.430376	6	17.4	2.326032
7	11.8	1.577424	7	19.8	2.646364
8	12.8	1.711104	8	22.2	2.967696
9	13.7	1.831416	9	24.6	3.288528
10	14.6	1.951728	10	27.0	3.60936
11	15.4	2.058672	11	27.8	3.716304
12	16.0	2.13888	12	28.6	3.823248
13	16.5	2.20572	13	29.4	3.930192
14	17.0	2.27256	14	30.2	4.037136
15	17.5	2.3394	15	31.0	4.14408
16	18.0	2.40624	16	31.8	4.241024
17	18.4	2.459712	17	32.6	4.357968
18	18.8	2.513184	18	33.4	4.464912
19	19.2	2.566656	19	34.2	4.571856
20	19.6	2.620128	20	35.0	4.6788
25	21.5	2.87412	25	38.0	5.07984

PUBLIC HEALTH—SANITARY CODE

Table 1805.C Table for Estimating Demand					
Supply Systems Predominantly for Flush Tanks			Supply Systems Predominantly for Flush Valves		
Load	Demand		Load	Demand	
30	23.3	3.114744	30	42.0	5.61356
35	24.9	3.328632	35	44.0	5.88192
40	26.3	3.515784	40	46.0	6.14928
45	27.7	3.702936	45	48.0	6.41664
50	29.1	3.890088	50	50.0	6.684
60	32.0	4.27776	60	54.0	7.21872
70	35.0	4.6788	70	58.0	7.75344
80	38.0	5.07984	80	61.2	8.181216
90	41.0	5.48088	90	64.3	8.595624
100	43.5	5.81508	100	67.5	9.0234
120	48.0	6.41664	120	73.0	9.75864
140	52.5	7.0182	140	77.0	10.29336
160	57.0	7.61976	160	81.0	10.82808
180	61.0	8.15448	180	85.5	11.42964
200	65.0	8.6892	200	90.0	12.0312
225	70.0	9.3576	225	95.5	12.76644
250	75.0	10.0260	250	101.0	13.50168
275	80.0	10.6944	275	104.5	13.96956
300	85.0	11.3628	300	108.0	14.43744
400	105.0	14.0364	400	127.0	16.97736
500	124.0	16.57632	500	143.0	19.11624
750	170.0	22.7256	750	177.0	23.66136
1000	208.0	27.80544	1000	208.0	27.80544
1250	239.0	31.94952	1250	239.0	31.94952
1500	269.0	35.95992	1500	269.0	35.95992
1750	297.0	39.70296	1750	297.0	39.70296
2000	325.0	43.446	2000	325.0	43.446
2500	380.0	50.7984	2500	380.0	50.7984
3000	433.0	57.88344	3000	433.0	57.88344
4000	535.0	70.182	4000	525.0	70.182
5000	593.0	79.27224	5000	593.0	79.27224

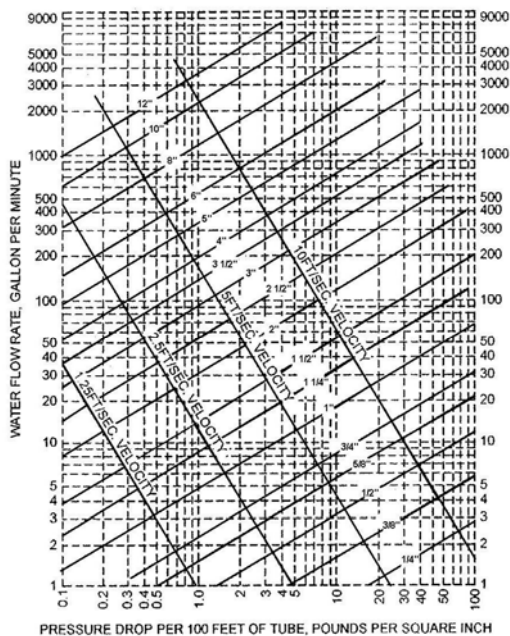
Table 1805.D Loss of Pressure through Taps and Tees in Pounds Per Square Inch (psi)							
Gallons per Minute	Size of Tap or Tee (In)						
	5/8	3/4	1	1 1/4	1 1/2	2	3
10	1.35	0.64	0.18	0.08	-	-	-
20	5.38	2.54	0.77	0.31	0.14	-	-
30	12.1	5.72	1.62	0.69	0.33	0.10	-
40	-	10.2	3.07	1.23	0.58	0.18	-
50	-	15.9	4.49	1.92	0.91	0.28	-
60	-	-	6.46	2.76	1.31	0.40	-
70	-	-	8.79	3.76	1.78	0.55	0.10
80	-	-	11.5	4.90	2.32	0.72	0.13
90	-	-	14.5	6.21	2.94	0.91	0.16
100	-	-	17.94	7.67	3.63	1.12	0.21
120	-	-	25.8	11.0	5.23	1.16	0.30
140	-	-	35.2	15.0	7.12	2.20	0.41
150	-	-	-	17.2	8.16	2.52	0.47
160	-	-	-	19.6	9.30	2.92	0.54
180	-	-	-	24.8	11.8	3.62	0.68
200	-	-	-	30.7	14.5	4.48	0.84
225	-	-	-	38.8	18.4	5.6	1.06
250	-	-	-	47.9	22.7	7.00	1.31
275	-	-	-	-	27.4	7.70	1.59
300	-	-	-	-	32.6	10.1	1.88

Table 1805.E Allowance in Equivalent Length of Pipe for Friction Loss in Valves and Threaded Fittings								
Fitting or Valve	Pipe Sizes (in)							
	1/2	3/4	1	1 1/4	1 1/2	2	2 1/2	3

45° elbow	1.2	1.5	1.8	2.4	3.0	4.0	5.0	6.0
90° elbow	2.0	2.5	3.0	4.0	5.0	7.0	8.0	10.0
Tee, run	0.6	0.8	0.9	1.2	1.5	2.0	2.5	3.0
Tee, branch	3.0	4.0	5.0	6.0	7.0	10.0	12.0	15.0
Gate valve	0.4	0.5	0.6	0.8	1.0	1.3	1.6	2.0
Balancing valve	0.8	1.1	1.5	1.9	2.2	3.0	3.7	4.5
Plug-type cock	0.8	1.1	1.5	1.9	2.2	3.0	3.7	4.5
Check valve, swing	5.6	8.4	11.2	14.0	16.8	22.4	28.0	33.6
Globe valve	15.0	20.0	25.0	35.0	45.0	55.0	65.0	80.0
Angle valve	8.0	12.0	15.0	18.0	22.0	28.0	34.0	40.0

Table 1805.F Allowance in Equivalent Length of Tube for Friction Loss in Valves and Fittings <sup>1</sup> (Copper Water Tube)								
Fitting or valve	Tube Sizes (in)							
	1/2	3/4	1	1 1/4	1 1/2	2	2 1/2	3
45° elbow (wrought)	0.5	0.5	1.0	1.0	2.0	2.0	3.0	4.0
90° elbow (wrought)	0.5	1.0	1.0	2.0	2.0	2.0	2.0	3.0
Tee, run (wrought)	0.5	0.5	0.5	0.5	1.0	1.0	2.0	-
Tee, branch (wrought)	1.0	2.0	3.0	4.0	5.0	7.0	9.0	-
45° elbow (cast)	0.5	1.0	2.0	2.0	3.0	5.0	8.0	1.0
90° elbow (cast)	1.0	2.0	4.0	5.0	8.0	11.0	14.0	18.0
Tee, run (cast)	0.5	0.5	0.5	1.0	1.0	2.0	2.0	2.0
Tee, branch (cast)	2.0	3.0	5.0	7.0	9.0	12.0	16.0	20.0
Compression Stop	13.0	21.0	30.0	-	-	-	-	-
Globe valve	7.5	10.0	12.5	53.0	66.0	90.0	33	40
Gate valve	0.5	0.25	1.0	1.0	2.0	2.0	2.0	2.0

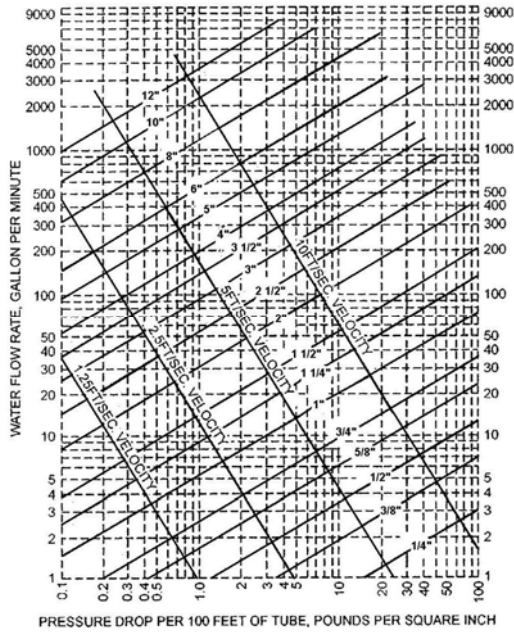
NOTE:  
1. From "Copper Tube Handbook" by Copper Development Association, Inc.



NOTE: FLUID VELOCITIES IN EXCESS OF 5 TO 8 FT/SEC. ARE NOT USUALLY RECOMMENDED

Figure 1805.A.1—Friction Loss in Smooth Pipe<sup>1</sup>  
(Type K, ASTM B88 Copper Tubing)

NOTE:  
1. This chart applies to smooth new copper tubing with recessed (Streamline) soldered joints and to the actual sizes of types indicated on the diagram.

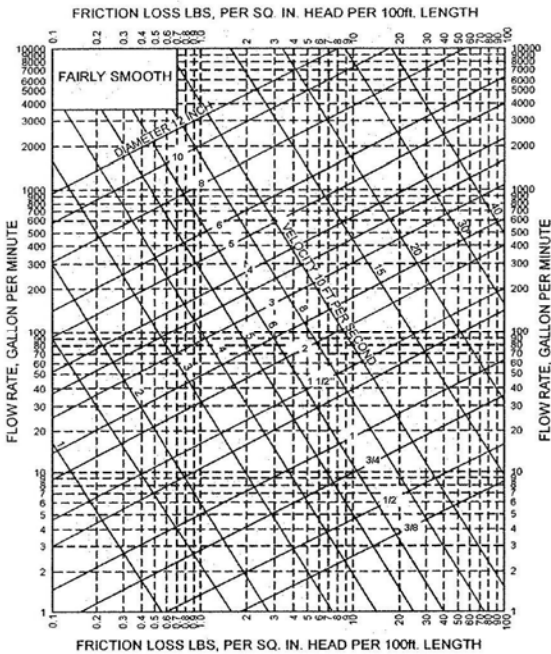


NOTE: FLUID VELOCITIES IN EXCESS OF 5 TO 8 FT/SEC. ARE NOT USUALLY RECOMMENDED

**Figure 1805.A.2—Friction Loss in Smooth Pipe<sup>1</sup>**  
(Type L, ASTM B88 Copper Tubing)

NOTE:

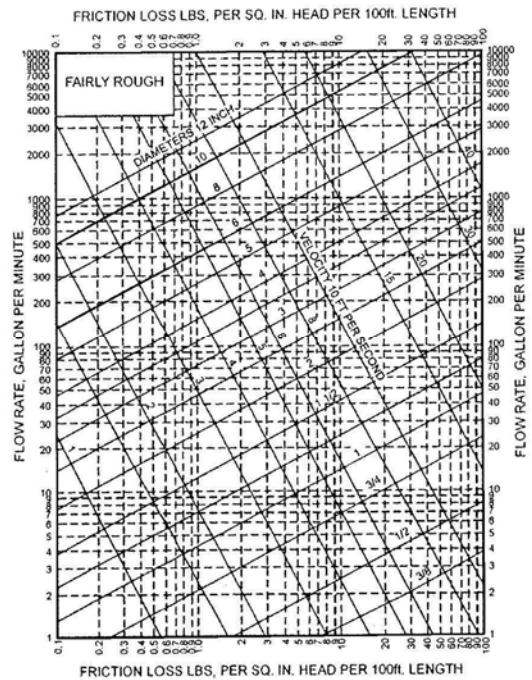
1. This chart applies to smooth new copper tubing with recessed (Streamline) soldered joints and to the actual sizes of types indicated on the diagram.



**Figure 1805.B—Friction Loss in Fairly Smooth Pipe<sup>1</sup>**

NOTE:

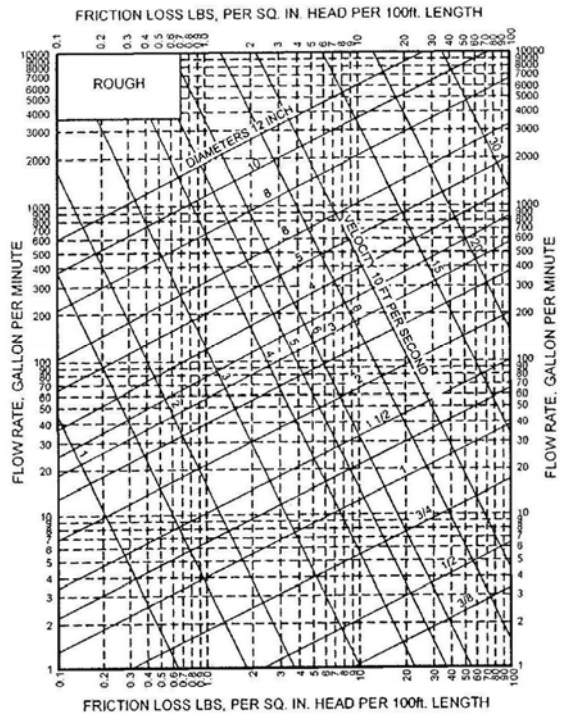
1. This chart applies to new steel (fairly smooth) pipe and to actual diameters of standard-weight pipe.



**Figure 1805.C—Friction Loss in Fairly Rough Pipe<sup>1</sup>**

NOTE:

1. This chart applies to fairly rough pipe and to actual diameters which in general will be less than the actual diameters of the new pipe of the same kind.



**Figure 1805.D—Friction Loss In Rough Pipe<sup>1</sup>**

NOTE:

1. This chart applies to very rough pipe and existing pipe and to their actual diameters.

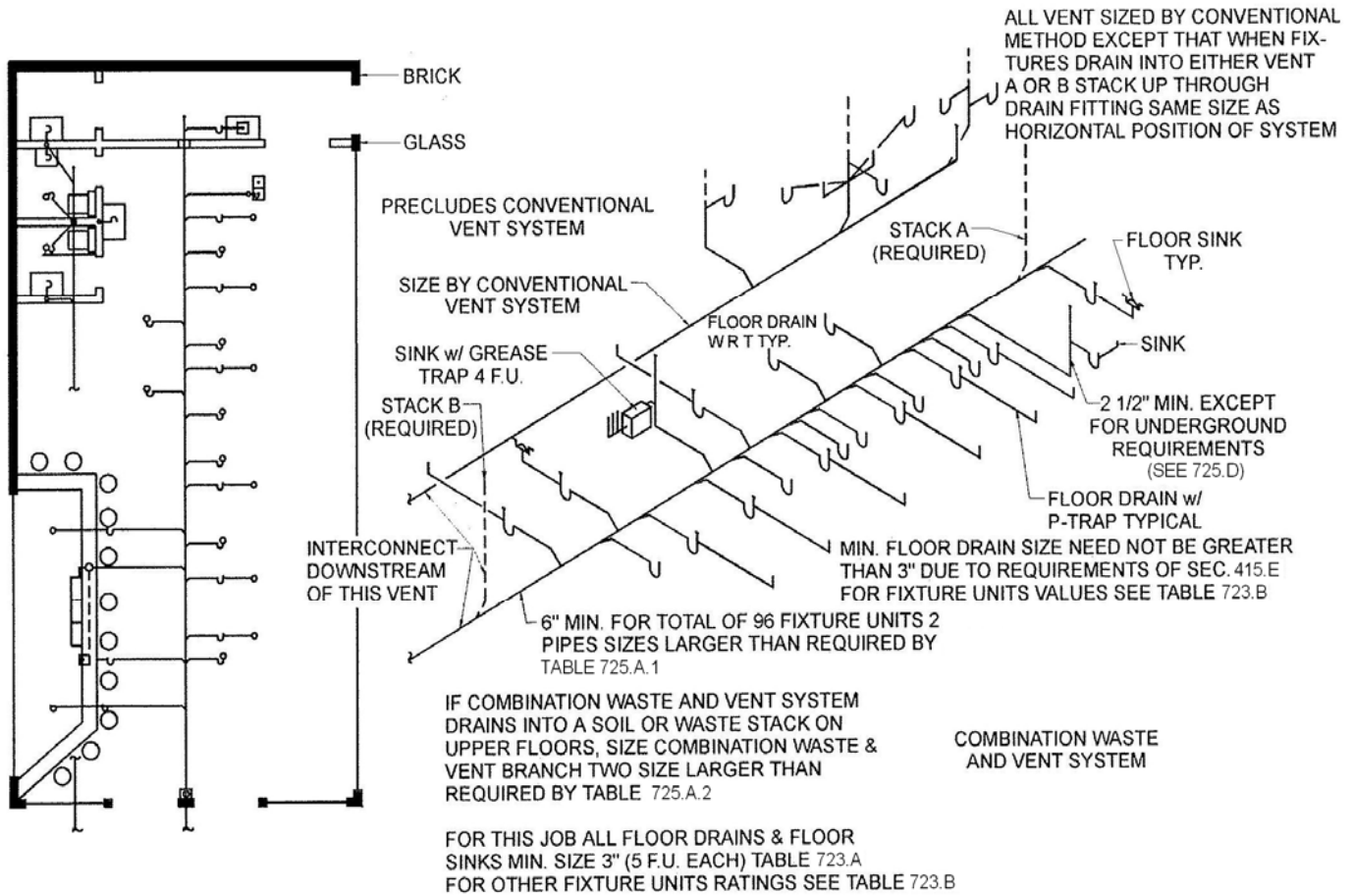
AUTHORITY NOTE: Promulgated in accordance with R.S. 40:4(A)(7) and R.S. 40:5(2)(3)(7)(9)(16)(17)(20).

HISTORICAL NOTE: Promulgated by the Department of Health and Hospitals, Office of Public Health, LR 38:2900 (November 2012).

**§1807. Appendix C—Illustrations**  
**[formerly Appendix J—Illustrations]**

A. The following figures have been included to aid in interpreting this code. The figures are not to be construed as superseding the written text, but merely to illustrate. The

various methods indicated diagrammatically do not limit other configurations of design of plumbing, soil, waste and vent systems, water piping, accessories, etc., when in compliance with the written text. It is further suggested that the users of these illustrations refer to the appropriate Sections and standards regarding any of the figures to avoid misunderstanding.



**Figure 1—Combination Waste and Vent System**

NOTE: A combination waste and vent system is considered an alternate designed plumbing system and requires special approval of the plans and specifications, etc., by the state health officer prior to construction. Refer to the provisions contained in Chapter 12 of this code for any alternate designed plumbing system.

EXAMPLES OF DISTANCES PERMITTED IN A COMBINATION WASTE AND VENT SYSTEM

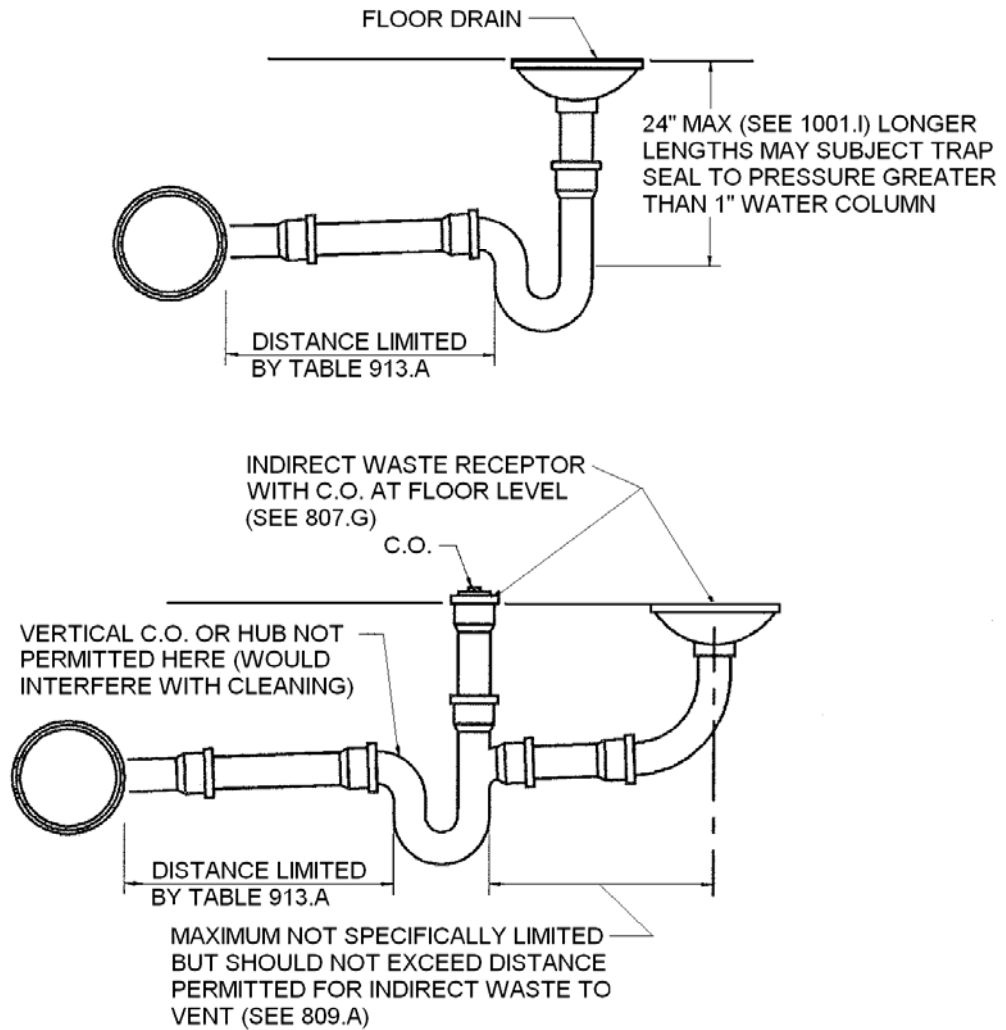
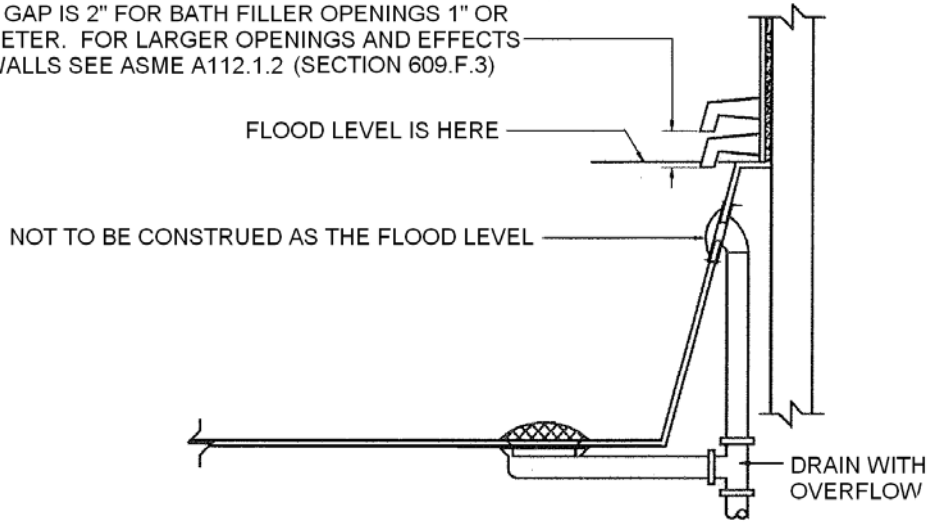


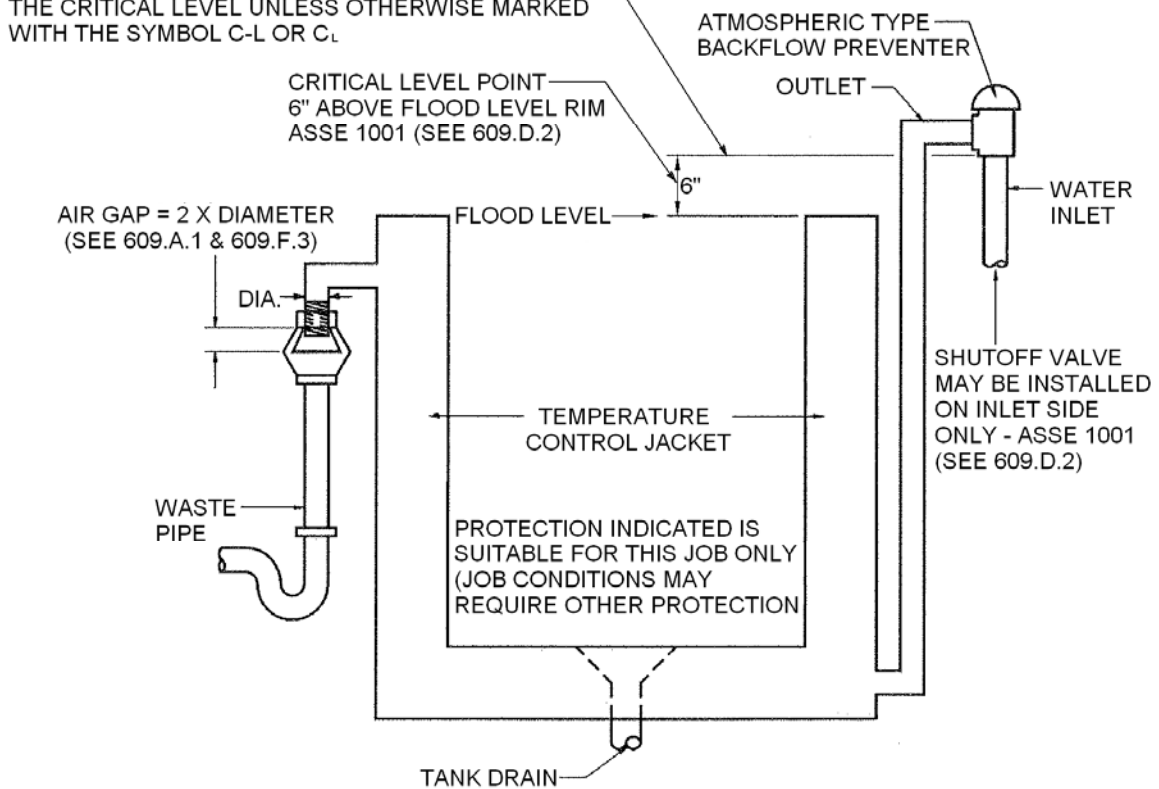
Figure 2—Distances Permitted in a Combination Waste and Vent System

NOTE: A combination waste and vent system is considered an alternate designed plumbing system and requires special approval of the plans and specifications, etc., by the state health officer prior to construction. Refer to the provisions contained in Chapter 12 of this code for any alternate designed plumbing system.

MINIMUM AIR GAP IS 2" FOR BATH FILLER OPENINGS 1" OR LESS IN DIAMETER. FOR LARGER OPENINGS AND EFFECTS FROM SIDE WALLS SEE ASME A112.1.2 (SECTION 609.F.3)



THE BOTTOM OF THE BACKFLOW PREVENTER IS THE CRITICAL LEVEL UNLESS OTHERWISE MARKED WITH THE SYMBOL C-L OR C<sub>L</sub>



CHEMICAL MIXING TANK WITH WATER JACKET (SEE SECTION 609)

Figure 3—Bathtub and Chemical Mixing Tank Illustrations



PUBLIC HEALTH—SANITARY CODE

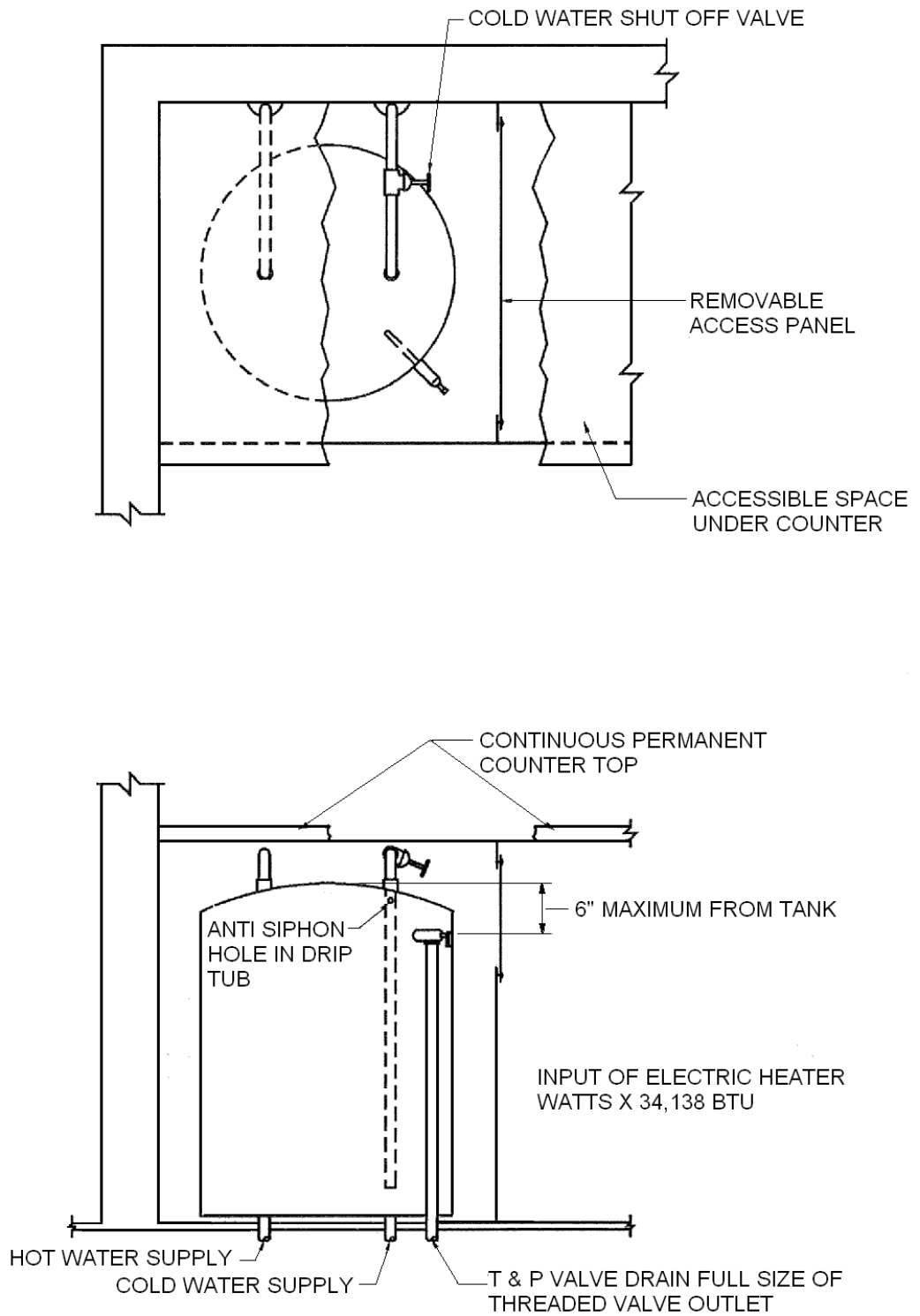


Figure 4—Access to Built-In Water Heater

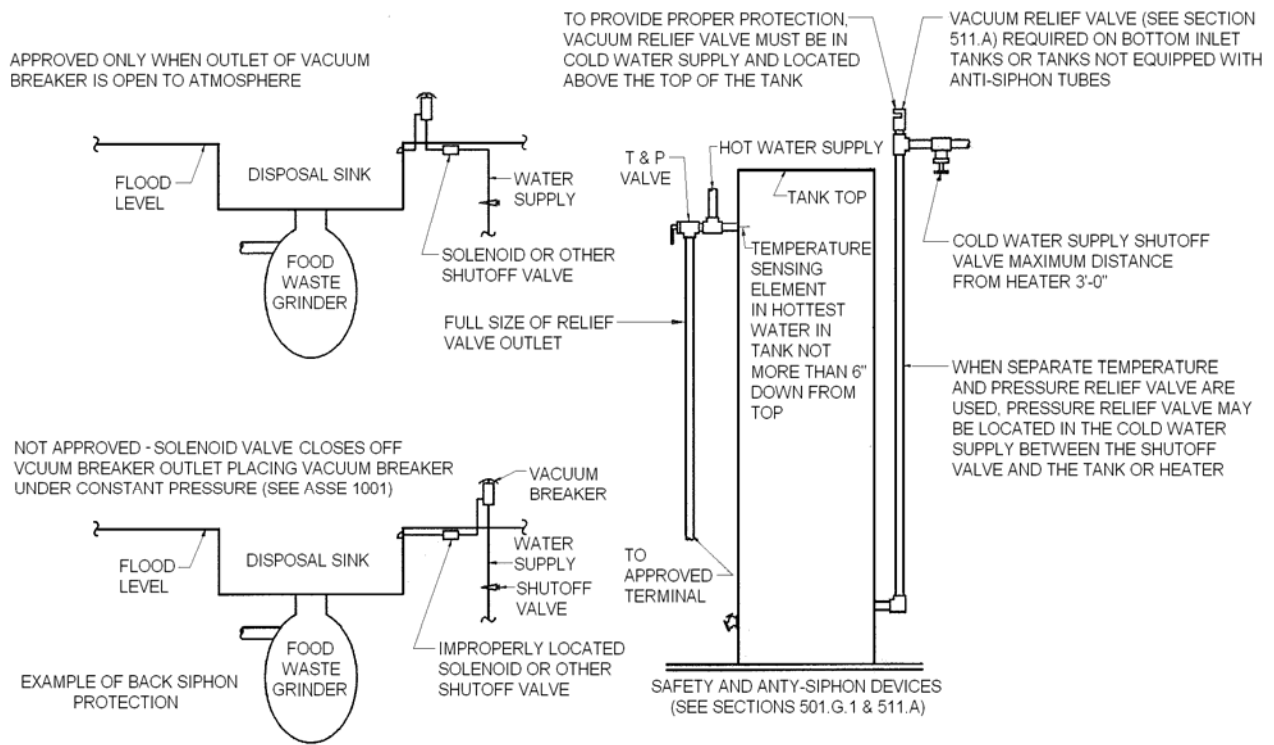
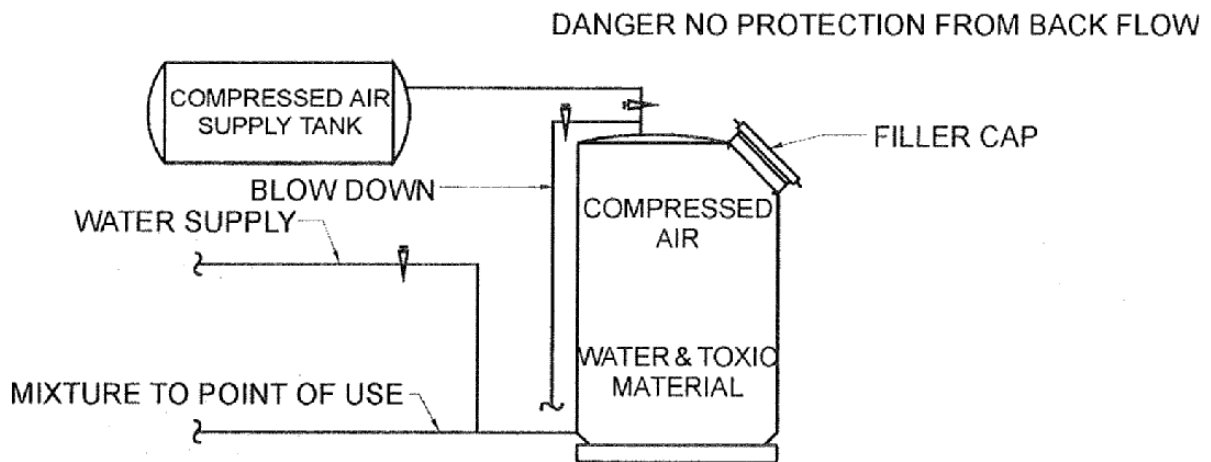
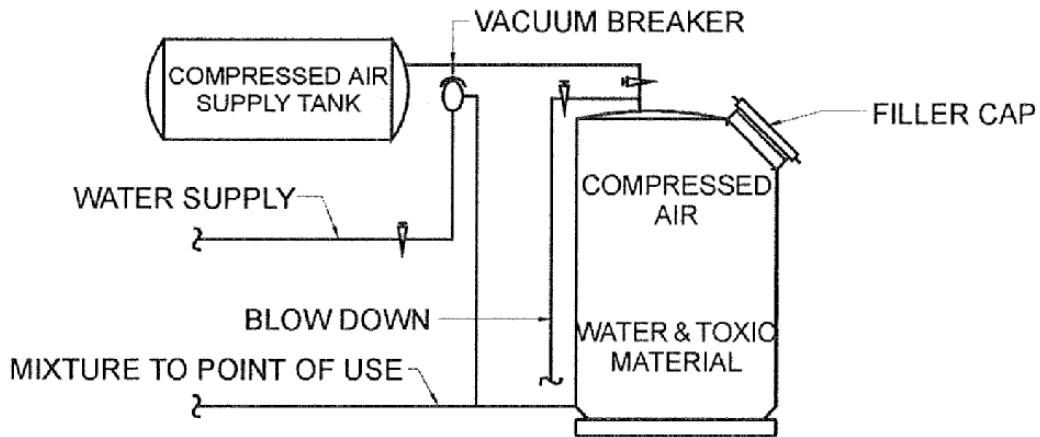


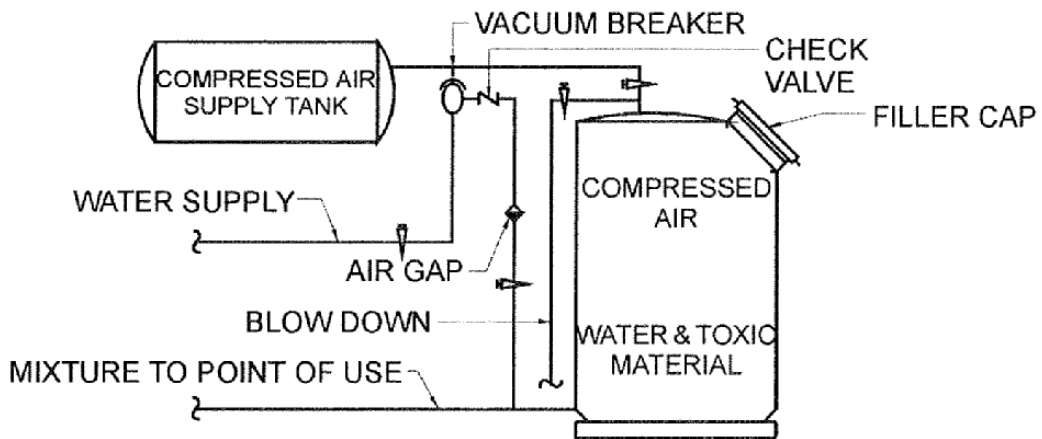
Figure 5—Examples of Back Siphon Backflow Protection



DANGER INADEQUATE PROTECTION FROM BACK-FLOW



SAFE PROTECTED FROM BACK-FLOW



HIGH PRESSURE UNITS SUCH AS USED IN CAR WASHERS TO SUPPLY WATER & DETERGENT TO WHEEL WASH & OTHER UNITS UNDER HIGH PRESSURE

Figure 6—Examples of Proper and Improper Backflow Protection

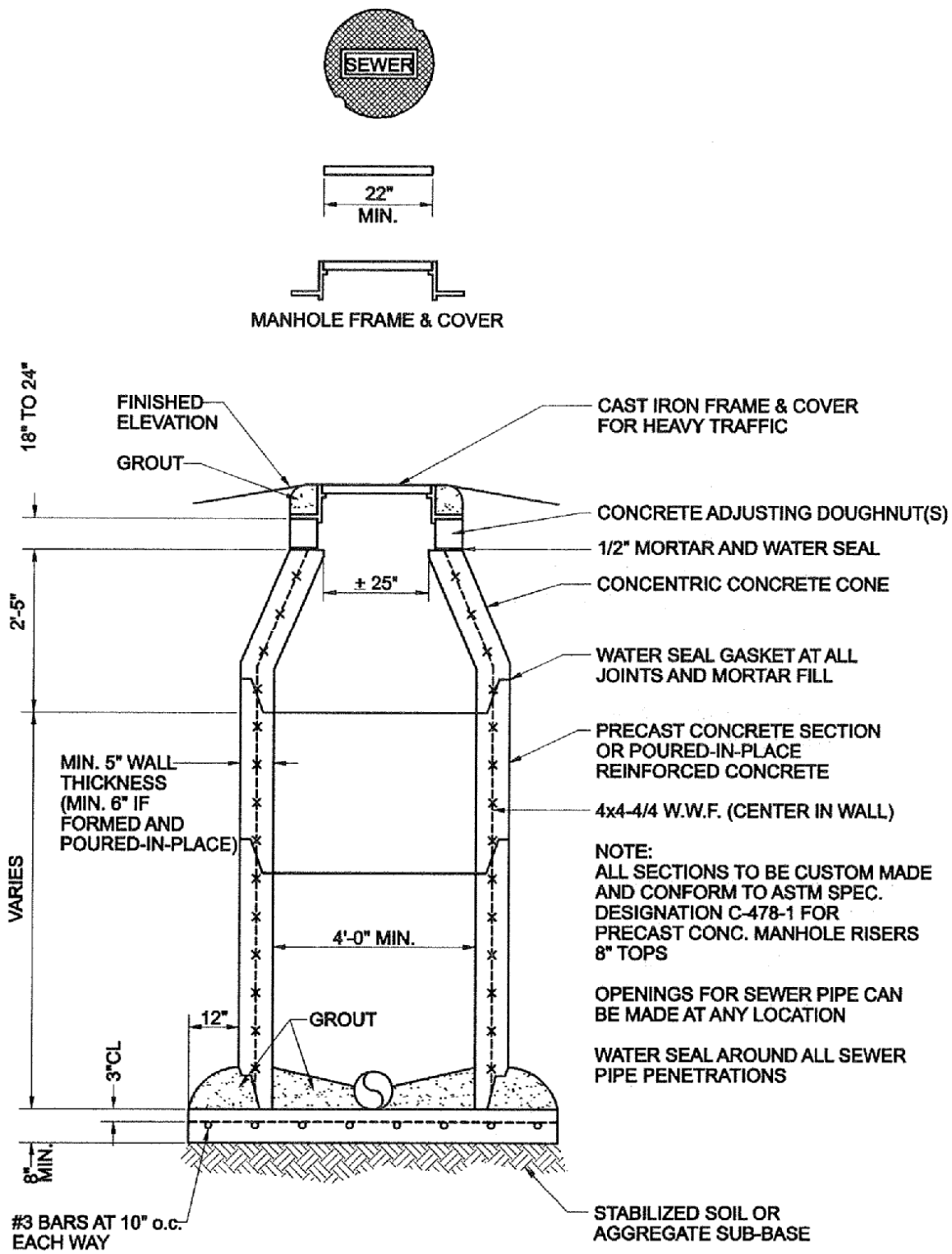


Figure 7—Typical Sewer Manhole

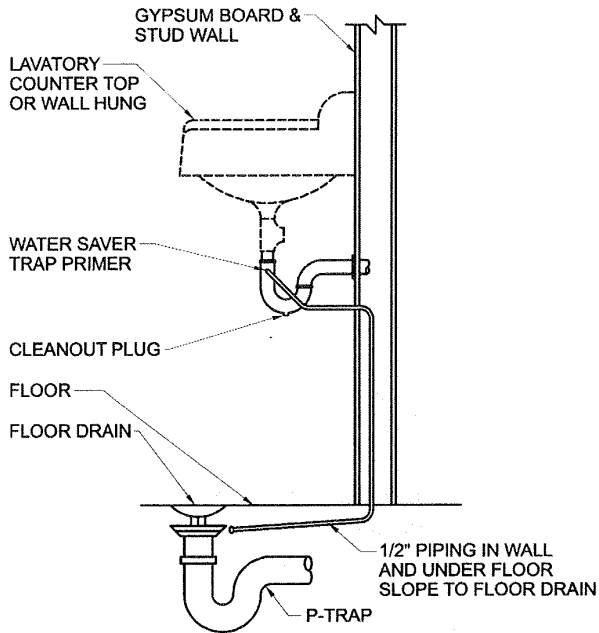


Figure 8—Floor Drain Trap Primer Detail

Alternate Grease Trap Sizing Formula								
Number of Meals Per Peak Hour <sup>1</sup>	x	Waste Flow Rate <sup>2</sup>	x	Retention Time <sup>3</sup>	x	Storage Factor <sup>4</sup>	=	Intercept or Size (liquid Capacity)
<b>1. Meals Served at Peak Hour</b>								
<b>2. Waste Flow Rate</b>								
a. With dishwashing machine						6 gallon (22.7 L) flow		
b. Without dishwashing machine						5 gallon (18.9 L) flow		
c. Single service kitchen						2 gallon (7.6L) flow		
d. Food waste disposer						1 gallon (3.8L) flow		
<b>3. Retention Times</b>								
Commercial kitchen waste dishwasher						2.5 hours		
Single service kitchen single serving						1.5 hours		
<b>4. Storage Factors</b>								
Fully equipped commercial kitchen						8 hour operation: 1.0		
						16 hour operation: 2.0		
						24 hour operation: 3.0		
Single Service Kitchen						1.5		

Figure 9—Alternate Grease Trap Sizing Formula

Grease Trap Minimum Capacity WITHOUT Garbage Grinder					
Retail Food Usable Square Footage (ft <sup>2</sup> ) <sup>1</sup>	Institutions Estimated People or Meals Served <sup>2</sup>	Grease Trap Size (gallons)	Retail Food Usable Square Footage (ft <sup>2</sup> ) <sup>1</sup>	Institutions Estimated People or Meals Served <sup>2</sup>	Grease Trap Size (gallons)
Less than 1,001	Up to 50		125	10,401-10,600	
1,001-1,200	51-60	150	10,601-10,800	531-540	1,350
1,201-1,400	61-70	175	10,801-11,000	541-550	1,375
1,401-1,600	71-80	200	11,001-11,200	551-560	1,400
1,601-1,800	81-90	225	11,201-11,400	561-570	1,425
1,801-2,000	91-100	250	11,401-11,600	571-580	1,450
2,001-2,200	101-110	275	11,601-11,800	581-590	1,475
2,201-2,400	111-120	300	11,801-12,000	591-600	1,500
2,401-2,600	121-130	325	12,001-12,200	601-610	1,525
2,601-2,800	131-140	350	12,201-12,400	611-620	1,550
2,801-3,000	141-150	375	12,401-12,600	621-630	1,575
3,001-3,200	151-160	400	12,601-12,800	631-640	1,600
3,201-3,400	161-170	425	12,801-13,000	641-650	1,625
3,401-3,600	171-180	450	13,001-13,200	651-660	1,650
3,601-3,800	181-190	475	13,201-13,400	661-670	1,675
3,801-4,000	191-200	500	13,401-13,600	671-680	1,700
4,001-4,200	201-210	525	13,601-13,800	681-690	1,725
4,201-4,400	211-220	550	13,801-14,000	691-700	1,750
4,401-4,600	221-230	575	14,001-14,200	701-710	1,775
4,601-4,800	231-240	600	14,201-14,400	711-720	1,800
4,801-5,000	241-250	625	14,401-14,600	721-730	1,825
5,001-5,200	251-260	650	14,601-14,800	731-740	1,850
5,201-5,400	261-270	675	14,801-15,000	741-750	1,875
5,401-5,600	271-280	700	15,001-15,200	751-760	1,900
5,601-5,800	281-290	725	15,201-15,400	761-770	1,925
5,801-6,000	291-300	750	15,401-15,600	771-780	1,950
6,001-6,200	301-310	775	15,601-15,800	781-790	1,975
6,201-6,400	311-320	800	15,801-16,000	791-800	2,000
6,401-6,600	321-330	825	16,001-16,200	801-810	2,025
6,601-6,800	331-340	850	16,201-16,400	811-820	2,050
6,801-7,000	341-350	875	16,401-16,600	821-830	2,075
7,001-7,200	351-360	900	16,601-16,800	831-840	2,100
7,201-7,400	361-370	925	16,801-17,000	841-850	2,125
7,401-7,600	371-380	950	17,001-17,200	851-860	2,150
7,601-7,800	381-390	975	17,201-17,400	861-870	2,175
7,801-8,000	391-400	1,000	17,401-17,600	871-880	2,200
8,001-8,200	401-410	1,025	17,601-17,800	881-890	2,225

Grease Trap Minimum Capacity WITHOUT Garbage Grinder					
Retail Food	Institutions	Grease Trap Size (gallons)	Retail Food	Institutions	Grease Trap Size (gallons)
Usable Square Footage (ft <sup>2</sup> ) <sup>1</sup>	Estimated People or Meals Served <sup>2</sup>		Usable Square Footage (ft <sup>2</sup> ) <sup>1</sup>	Estimated People or Meals Served <sup>2</sup>	
8,201-8,400	411-420	1,050	17,801-18,000	891-900	2,250
8,401-8,600	421-430	1,075	18,001-18,200	901-910	2,275
8,601-8,800	431-440	1,100	18,201-18,400	911-920	2,300
8,801-9,000	441-450	1,125	18,401-18,600	921-930	2,325
9,001-9,200	451-460	1,150	18,601-18,800	931-940	2,350
9,201-9,400	461-470	1,175	18,801-19,000	941-950	2,375
9,401-9,600	471-480	1,200	19,001-19,200	951-960	2,400
9,601-9,800	481-490	1,225	19,201-19,400	961-970	2,425
9,801-10,000	491-500	1,250	19,401-19,600	971-980	2,450
10,001-10,200	501-510	1,275	19,601-19,800	981-990	2,475
10,201-10,400	511-520	1,300	19,801-20,000	991-1,000	2,500

<sup>1</sup> Retail establishments expected to serve more meals than estimated by usable sq ft shall install the larger size grease trap.

<sup>2</sup> Estimated # of people or meals served is the # of persons or meals served during the largest meal period.

Figure 10—Grease Trap Sizing Chart (Without Garbage Grinder)

Grease Trap Minimum Capacity WITH Garbage Grinder					
Retail Food	Institutions	Grease Trap Size (gallons)	Retail Food	Institutions	Grease Trap Size (gallons)
Usable Square Footage (ft <sup>2</sup> ) <sup>1</sup>	Estimated People or Meals Served <sup>2</sup>		Usable Square Footage (ft <sup>2</sup> ) <sup>1</sup>	Estimated People or Meals Served <sup>2</sup>	
Less than 1,001	Up to 50	500	10,401-10,600	521-530	1,700
1,001-1,200	51-60	525	10,601-10,800	531-540	1,725
1,201-1,400	61-70	550	10,801-11,000	541-550	1,750
1,401-1,600	71-80	575	11,001-11,200	551-560	1,775
1,601-1,800	81-90	600	11,201-11,400	561-570	1,800
1,801-2,000	91-100	625	11,401-11,600	571-580	1,825
2,001-2,200	101-110	650	11,601-11,800	581-590	1,850
2,201-2,400	111-120	675	11,801-12,000	591-600	1,875
2,401-2,600	121-130	700	12,001-12,200	601-610	1,900
2,601-2,800	131-140	725	12,201-12,400	611-620	1,925
2,801-3,000	141-150	750	12,401-12,600	621-630	1,950
3,001-3,200	151-160	775	12,601-12,800	631-640	1,975
3,201-3,400	161-170	800	12,801-13,000	641-650	2,000
3,401-3,600	171-180	825	13,001-13,200	651-660	2,025
3,601-3,800	181-190	850	13,201-13,400	661-670	2,050
3,801-4,000	191-200	875	13,401-13,600	671-680	2,075
4,001-4,200	201-210	900	13,601-13,800	681-690	2,100
4,201-4,400	211-220	925	13,801-14,000	691-700	2,125
4,401-4,600	221-230	950	14,001-14,200	701-710	2,150
4,601-4,800	231-240	975	14,201-14,400	711-720	2,175
4,801-5,000	241-250	1,000	14,401-14,600	721-730	2,200
5,001-5,200	251-260	1,025	14,601-14,800	731-740	2,225
5,201-5,400	261-270	1,050	14,801-15,000	741-750	2,250
5,401-5,600	271-280	1,075	15,001-15,200	751-760	2,275
5,601-5,800	281-290	1,100	15,201-15,400	761-770	2,300
5,801-6,000	291-300	1,125	15,401-15,600	771-780	2,325
6,001-6,200	301-310	1,150	15,601-15,800	781-790	2,350
6,201-6,400	311-320	1,175	15,801-16,000	791-800	2,375
6,401-6,600	321-330	1,200	16,001-16,200	801-810	2,400
6,601-6,800	331-340	1,225	16,201-16,400	811-820	2,425
6,801-7,000	341-350	1,250	16,401-16,600	821-830	2,450
7,001-7,200	351-360	1,275	16,601-16,800	831-840	2,475
7,201-7,400	361-370	1,300	16,801-17,000	841-850	2,500
7,401-7,600	371-380	1,325	17,001-17,200	851-860	2,525
7,601-7,800	381-390	1,350	17,201-17,400	861-870	2,550
7,801-8,000	391-400	1,375	17,401-17,600	871-880	2,575
8,001-8,200	401-410	1,400	17,601-17,800	881-890	2,600
8,201-8,400	411-420	1,425	17,801-18,000	891-900	2,625
8,401-8,600	421-430	1,450	18,001-18,200	901-910	2,650
8,601-8,800	431-440	1,475	18,201-18,400	911-920	2,675
8,801-9,000	441-450	1,500	18,401-18,600	921-930	2,700
9,001-9,200	451-460	1,525	18,601-18,800	931-940	2,725
9,201-9,400	461-470	1,550	18,801-19,000	941-950	2,750

PUBLIC HEALTH—SANITARY CODE

Grease Trap Minimum Capacity WITH Garbage Grinder					
Retail Food		Grease Trap Size (gallons)	Institutions		Grease Trap Size (gallons)
Usable Square Footage (ft <sup>2</sup> ) <sup>1</sup>	Estimated People or Meals Served <sup>2</sup>		Usable Square Footage (ft <sup>2</sup> ) <sup>1</sup>	Estimated People or Meals Served <sup>2</sup>	
9,401-9,600	471-480	1,575	19,001-19,200	951-960	2,775
9,601-9,800	481-490	1,600	19,201-19,400	961-970	2,800
9,801-10,000	491-500	1,625	19,401-19,600	971-980	2,825
10,001-10,200	501-510	1,650	19,601-19,800	981-990	2,850
10,201-10,400	511-520	1,675	19,801-20,000	991-1,000	2,875

- 1 Retail establishments expected to serve more meals than estimated by usable sq ft shall install the larger size grease trap.
- 2 Estimated # of people or meals served is the # of persons or meals served during the largest meal period.

**Figure 11—Grease Trap Sizing Chart (With Garbage Grinder)**





AUTHORITY NOTE: Promulgated in accordance with R.S. 40:4(A)(7) and R.S. 40:5(2)(3)(7)(9)(16)(17)(20).

HISTORICAL NOTE: Promulgated by the Department of Health and Hospitals, Office of Public Health, LR 38:2907 (November 2012).

**§1809. Appendix D—Vacuum Drainage Systems  
[formerly Appendix K—Vacuum Drainage  
Systems]**

A. System. A vacuum drainage system shall comply with the following.

1. General. Since a vacuum drainage system is considered an alternate designed plumbing system, the requirements of Chapter 12 of this code shall apply and such systems shall be considered on an individual basis.

2. System Design. Vacuum drainage systems shall be designed in accordance with manufacturer's specifications. The system arrangement, including piping, tank assemblies, vacuum pump assembly and other components necessary for proper function of the system shall be in accordance with manufacturer's specifications. In general, vacuum drainage systems may be considered for approval by the state health officer for use on handling island display refrigerator/freezer condensate wastes in grocery stores. Such wastes from display refrigerators/freezers handling meat or dairy products or other products containing fats, grease or oils shall discharge, in an approved manner, through an approved grease trap prior to discharge into the sanitary sewer system. Also, any food items stored below any portion of a vacuum drainage system (for example, in-the-ceiling vacuum waste piping located above food shelves or food preparation areas) shall be protected from potential contamination by adequate shielding to intercept any potential drips (in accord with LAC 51:XXIII.1503.A.6). Vacuum drainage systems for liquid wastes from other types of plumbing fixtures, such as sinks, water closets, etc., are discouraged. A standby emergency generator, permanently wired to automatically operate the vacuum pump motor upon lost of the normal power source, should be installed to ensure continuous operation of a vacuum drainage system.

3. Plans and specifications. Plans and specifications for such systems shall be designed by a Louisiana Registered Professional Engineer registered in either civil or mechanical engineering and submitted to the state health officer for review and approval prior to installation.

B. Fixtures. Gravity type fixtures used in vacuum drainage systems shall comply with Chapter 4 of this code.

C. Drainage Fixture Units. The drainage fixture load of gravity drainage systems which discharge into or receive discharge from vacuum drainage systems shall be based upon values in Chapter 7 of this code.

D. Water Supply Fixture Units. Water supply fixture load shall be based upon values in Table 1805.B of this code. The load requirement of a vacuum type water closet shall be determined per manufacturer's specifications.

E. Traps and Cleanouts. Gravity type fixtures shall be provided with traps and cleanouts in accordance with Chapters 7 and 10 of this code.

F. Materials. Vacuum drainage pipe, fitting and valve materials shall be as specified by the vacuum drainage system manufacturer and as listed in this Part.

G. Tests and Demonstrations. After completion of the entire system installation, the system shall be subjected to a vacuum test of 19 inches of mercury (64 kPa) and shall be operated to function as required by the state health officer and/or the local plumbing official and the manufacturer. Tests shall be witnessed by the state health officer and/or the local plumbing official. The results of such tests shall be submitted to the state health officer and the local plumbing official.

H. Written Instructions. Written instructions for the operations, maintenance, safety and emergency procedures shall be provided to the building owner and shall be available for inspection by the state health officer and the local plumbing official at any time.

AUTHORITY NOTE: Promulgated in accordance with R.S. 40:4(A)(7) and R.S. 40:5(2)(3)(7)(9)(16)(17)(20).

HISTORICAL NOTE: Promulgated by the Department of Health and Hospitals, Office of Public Health, AUTHORITY NOTE: Promulgated in accordance with R.S. 40:4(A)(7) and R.S. 40:5(2)(3)(7)(9)(16)(17)(20).

HISTORICAL NOTE: Promulgated by the Department of Health and Hospitals, Office of Public Health, LR 38:2917 (November 2012).

**§1811. Appendix E—Alternate Designed Plumbing  
Systems  
[formerly Appendix L—Alternate Designed  
Plumbing Systems]**

A. General. Pursuant to the requirements of Chapter 12 of this code, the approval of alternate designed plumbing systems shall be considered on an individual basis.

1. Scope. The provisions of this appendix shall assist in governing the materials, design and installation of non-prescriptive plumbing systems, also known as alternate designed plumbing systems. In accord with the requirements of Chapter 12 of this code, any one of the systems mentioned in this appendix shall be designed by a Louisiana registered professional engineer registered in either civil or mechanical engineering. Any alternate designed plumbing system shall not be installed until the plans and specifications have been reviewed and approved by the state health officer, pursuant to the requirements of Chapter 12 of this code.

2. General System Provisions. Discharge pipe systems shall comprise the minimum of pipe work necessary to carry away the foul water from the building quickly and quietly, with freedom from nuisance or risk of injury to health.

B. Definitions

*Discharge Pipe*—a pipe which conveys the discharges from *plumbing fixtures* or appliances.

*Discharge Unit*—a unit so chosen that the relative load-producing effect of *plumbing fixtures* can be expressed as multiples of that unit. The *discharge unit* rating of a *fixture* depends on its rate and duration of discharge and on the interval between discharges. It is not a simple multiple of a rate of flow and is a different method of assessment than the *fixture unit* applicable to other Chapters of this Part and the two (*fixture unit* and *discharge unit*) cannot be interchanged.

*Fixture Tail Piece or Connection*—see definition under §203 of this code.

*Ventilating Pipe*—a pipe provided to facilitate the circulation of air within the system and to protect *trap seals* from excessive pressure fluctuation.

C. Combination Waste and Vent System. A combination waste and vent system is an alternate designed plumbing system; thus, the requirements of Chapter 12 of this code apply to any combination waste and vent system. Combination waste and vent systems shall conform with the following.

1. Approval. Plans and specifications for each combination waste and vent system shall be submitted to the state health officer for review and approval. Written approval of such plans and specifications shall be obtained before any installation is started.

2. Limits. The following limits shall be applied to any combination waste and vent system.

a. A combination waste and vent system is limited to dishwashers, floor sinks, indirect waste receptors, floor drains or similar fixtures which waste at or below floor level and where the fixtures are not adjacent to walls or partitions thus making it impractical to provide conventional venting. It consists of the installation of waste piping in which the trap of the fixture is not individually vented.

b. Caution must be exercised to exclude appurtenances delivering large quantities of water or sewage such as pumps, etc., in a combination waste and vent system in order that adequate venting will be maintained. Water closets, clinical sinks, and urinals shall not waste into a combination waste and vent system. Sinks, lavatories, etc., that waste above floor level should not be allowed to waste into a combination waste and vent system.

3. Dishwashers. Dishwashers, three-compartment sinks and other scullery sinks in commercial buildings shall drain through a grease interceptor sized in accordance with this code and they shall only then be allowed to discharge into the combination waste and vent system via a floor sink through an air gap (drainage system) or air break (drainage system). The purpose of this requirement is to keep grease out of the combination waste and vent system since such a system is not self-scouring due to the over-sized piping required.

4. General Design. The general design elements of a combination waste and vent system shall be as follows.

a. Every waste pipe and trap in this system shall be at least two pipe sizes larger than the conventional plumbing

size required in Chapter 7 of this code, and at least two pipe sizes larger than any fixture tail piece or connection. In addition, the fixture tail piece or connection itself shall remain normal size in order to limit the rate of flow and amount of wastewater allowed to enter the horizontal combination waste and vent waste pipe. In order to maintain a continuous vent space above the liquid waste within the horizontal waste pipe, all fixtures shall waste into the horizontal combination waste and vent waste pipe from the horizontal only. The fixture drain length to the horizontal combination waste and vent waste pipe shall be limited by Table 913.A of this code. Floor sinks shall be connected through a running trap two pipe sizes larger than the sink outlet. A vertical cleanout extension shall be provided on the top of the inlet side of the running trap and shall be accessible at floor level for rodding out the trap and fixture drain. Floor sink and waste piping from the floor sink to the trap shall be sized for the total fixture units draining thereto, based on Table 723.B of this code, but in no case shall the line be less than 2-inch (51 mm) waste pipe when piping is underground. In addition, the length of such piping should not exceed the distance permitted for indirect waste to vent (see §809.A.2, and Figure 2 in Section 1807 of this code).

b. A vent shall be provided at the upstream end of each branch, washed over or under by the last fixture on the branch. No vent shall take off from the horizontal waste branch at an angle of less than 45 degrees (0.785 rad) from the horizontal unless washed by a fixture. A vent shall be located at all points where branches intersect. A vent shall be located downstream from all fixtures in the system, in addition to the upstream vent, separating the combination waste and vent system from all other systems in the building. All vents in a combination waste and vent system shall be provided with an accessible above-grade<sub>(g)</sub> cleanout. Line cleanouts for horizontal waste piping shall be provided as required in Chapter 7 of this code. Drainage fixture pattern fittings shall be provided for all vent piping below the level of 6 inches (152 mm) above the flood-level rim of the highest fixture connection. No fixtures other than those permitted in §1811.C.2 of this code shall discharge into any branch or portion of this system. See Figures 6 and 7 in Section 1807 of this code.

c. Caution shall be used in the design of the system to assure that the vertical distance from fixture or drain outlet to trap weir does not exceed 24 inches (610 mm). Long runs shall be provided with additional relief vents located at intervals of not more than 100 ft (30.5 m) to equalize pressure in the system.

5. Size of Vents. The size of vents shall be in accordance with requirements of §937.B and Table 937.B of this code, but the internal cross-sectional area of the vent shall be not less than one-half of the internal cross-sectional area of the waste pipe served (normally, measured in square inches), except that the vents shall be the same size as the waste branch to a point at least 6 inches (152 mm) above the flood-level rim of the highest fixture connected before reduction, in accordance with Table 937.B of this code.

6. Receptor Drain Size. Indirect waste receptors shall be sized for the fixture units draining thereto, regardless of other requirements of this code.

#### D. Single Stack Discharge and Ventilating Systems

1. Approval. The purpose of this Subsection is to make provisions for the design and installation of a single stack discharge and ventilating plumbing system which is not otherwise allowed in this code. In accord with Chapter 12 of this code, the plumbing official shall require that the owner submit necessary plans and specifications to the state health officer by a Louisiana Registered Professional Engineer registered in either civil or mechanical engineering.

2. Tests. The single stack discharge and ventilating system shall be tested in accordance with §1205.C of this code.

3. General. The following general provisions are applicable to single stack discharge and ventilating systems.

a. Trap Function. To prevent exchange of air between the discharge pipe system and the inside of the building, a trap having an adequate water seal shall be provided for each fixture (see §1811.D.4 of this code). The discharge piping system shall be so designed as to retain adequate water seals in all traps under normal pressure fluctuations caused by discharge from fixtures (see §1205.C of this code). For design purposes, the effects of the flow of water in the branch connecting the fixture to the stack, and the flow of water down the stack, shall be considered separately. See §§1811.D.3.b and 1811.D.3.c of this code below.

b. Seal Loss (Branch Effect). Seal losses produced by flow in a branch depend on the following:

i. the design of the fixture (funnel shaped fixtures increase the chance of self-siphonage); and,

ii. the length and fall (slope or gradient) and the diameter of the pipe.

(a). Branch effects are not affected by the height of the building and they can therefore be controlled by limiting the length and the fall of the branch.

c. Seal Loss (Stack Effect). Seal losses produced by flow down the stack depend on the following:

i. the flow load (which depends on the number of fixtures connected to the stack and the frequency with which they are used);

ii. the diameter of the stack; and,

iii. the height of the stack.

(a). Excessive seal losses can be prevented by choosing a size of stack appropriate to the height of the building and to the number of fixtures connected to it.

d. Fixture Layout. Where the layout of fixtures is suitable, careful design and installation can lead to considerable economies in pipework by eliminating the need

for separate ventilating pipes (see §1811.D.6 of this code). Where these requirements cannot be followed, traps shall be ventilated by pipes of adequate size as described in §1811.D.7 of this code.

e. System Design. Consideration shall be given in design to the following points which, in addition to being good general practice, will also obviate trouble from the foaming of detergents.

i. Where practicable, all fixtures shall be connected to one main stack which is at least 4 inches in diameter except for one story buildings where a 3-inch stack may be satisfactory (see §1811.D.6 and Table 1811.D.5.5B of this code).

ii. Where sinks are connected to a separate stack, the stack shall be larger than normal (a minimum of 4-inch diameter for buildings over five stories) and connected directly to the building drain.

iii. For over two sinks, stacks shall be (when one sink is over another on separate floor levels) a minimum of 2 1/2-inch diameter.

iv. The interconnection of stacks is not permitted except when fixtures below such interconnection are vented as required elsewhere in this code.

v. For buildings more than five stories high, ground floor fixtures shall be connected separately to the building drain, and vented back into the main discharge stack above the fixtures on the floor above, or the vent shall be connected with a main ventilating stack when such stack is required by Table 1811.D.6C of this code.

vi. Bends and offsets in vertical stacks are prohibited.

f. Jointing and Support. The selection of materials, their jointing and support shall be in consideration of the effects of possible settlement, thermal movement, and corrosion (see §1811.D.9 of this code). Some materials may require protection against mechanical damage.

g. Access. There shall be adequate provision for access to pipework, and the embedding of joints in the structure shall be avoided (see §§1811.D.8 and 1811.D.10 of this code).

4. Traps. Traps shall meet the following requirements.

a. General. The entry of foul air from the drainage system into the building is prevented by the installation of suitable traps which are of self-cleansing design. A trap which is not an integral part of a fixture shall be attached to and immediately beneath the fixture outlet and the bore of the trap shall be smooth and uniform throughout.

b. Diameters. The internal diameters of traps shall be not less than those given in Table 1811.D.4 of this code.

Table 1811.D.4 Minimum Internal Diameters of Traps	
Type of Domestic Appliance	Min. Internal Diameter (in.)
Lavatory	1 1/4
Sink	1 1/2
Bath tub	1 1/2 or 2 <sup>1</sup>
Shower	2
Wash tub	1 1/2
Kitchen waste disposal unit (tubular trap is essential)	1 1/2

NOTE:

1. See Figures 1811.D.5.4A, 1811.D.5.4B, and Table 1811.D.5.5A of this code.

c. Depth of Seals. Traps of water closets shall have a minimum water seal of 2 inches (51 mm); traps of other fixtures shall have a minimum water seal of 3 inches (76 mm) for pipes up to and including 2 inches in diameter and 2-inch minimum water seal for pipes over 2 inches in diameter.

5. Discharge Pipes. Discharge pipes shall meet the following requirements.

a. Diameters. The internal diameter of a horizontal discharge pipe (fixture drain) shall normally be that of the trap to which it is attached, and in no case less, except that no fixture drain shall be less than 1 1/2-inch diameter.

b. Branch Gradients. The fall or slope of discharge pipes shall be adequate to drain the pipe efficiently and in no

case less than shown in Table 1811.D.5.5C of this code (see §1811.D.5.e of this code).

c. Bends, Branches and Offsets. All bends, branches and offsets shall be of easy radius and there shall be no restriction in the bore of the pipe.

d. Prevention of Cross Flow. To prevent water closet discharge from backing up a bath waste line, the latter shall be connected to the stack with its center line either at, above, or at least 8 inches (203 mm) below the center line of the water closet branch (see Figure 1811.D.5.4A of this code). Where this cannot be achieved, a parallel branch may be used (see Figure 1811.D.5.4B of this code). Alternatively, the level of the water closet branch connection may be modified as above by dotted lines in Figure 1811.D.5.4B of this code.

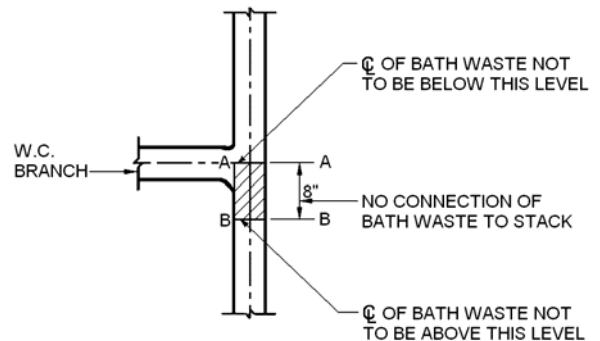
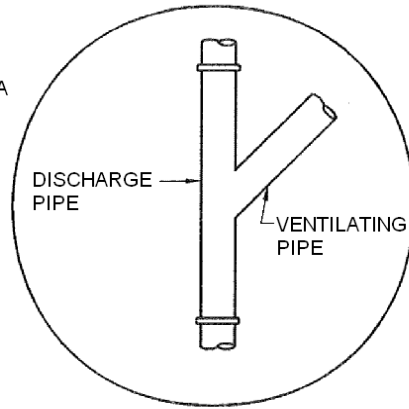
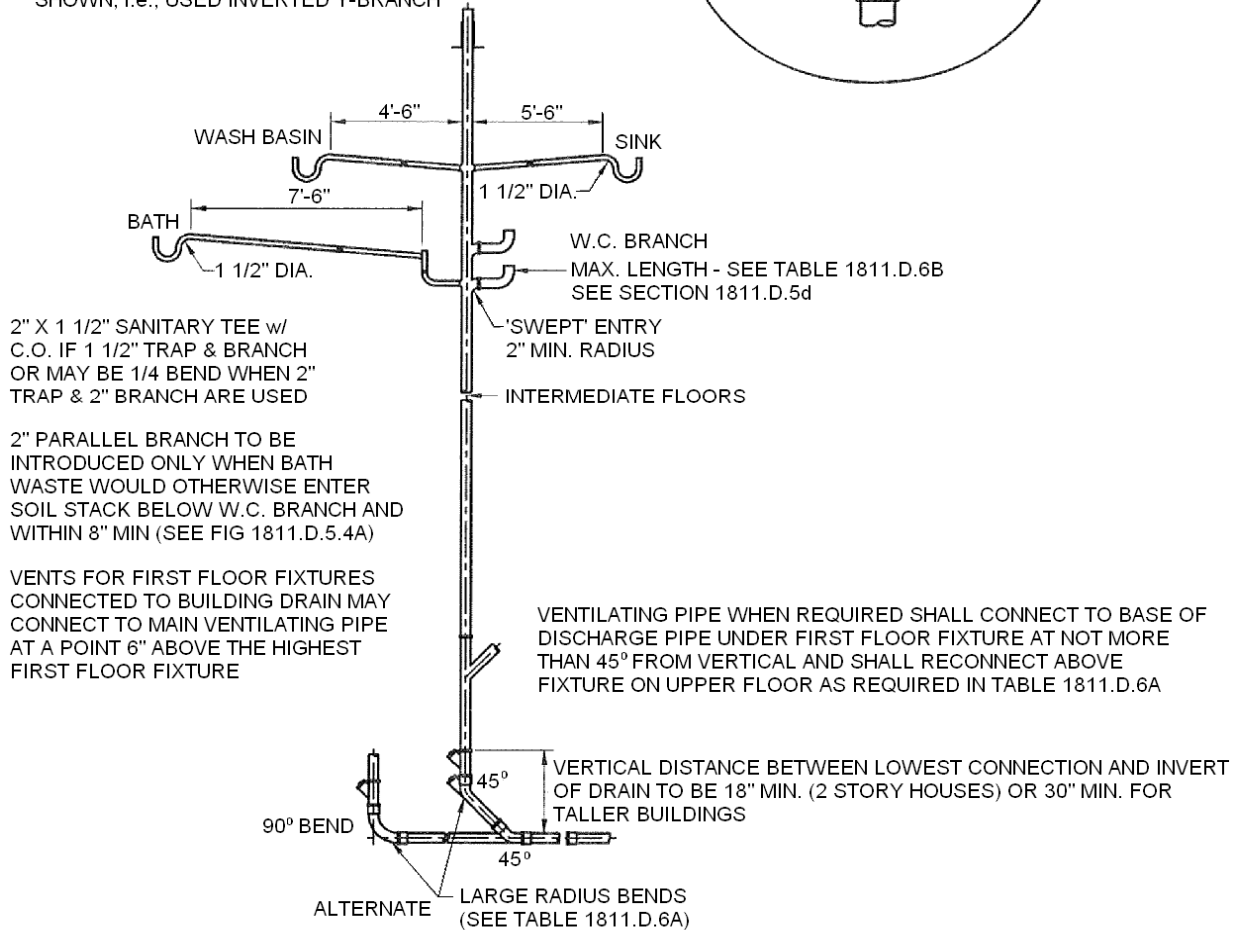


Figure 1811.D.5.4A

VENTILATION PIPES CONNECTING TO THE DISCHARGE STACK AT INTERMEDIATE LEVELS SHALL CONNECT IN A DOWNWARD DIRECTION 45° FROM THE VERTICAL



ON TOP FLOOR ONLY ABOVE HIGHEST FIXTURE BRANCH VENT FITTING TO BE REVERSE OF THAT SHOWN, i.e., USED INVERTED Y-BRANCH



1. FOR DEPTH OF TRAP SEALS SEE SECTION 1811.D.4
2. NO OFFSETS ARE PERMITTED BELOW THE CONNECTION OF THE TOPMOST FITTING OF THE STACK.
3. FALL OF BRANCH DISCHARGE PIPE VARIES WITH LENGTH.

Figure 1811.D.5.4B

e. Pipe Capacities. Discharge unit values for plumbing fixtures are given in Table 1811.D.5.5A of this code. For other fixtures the discharge unit value shall be taken as that given in Table 1811.D.5.5A of this code for a fixture with the same diameter trap with a comparable use interval. Where other use intervals are expected, the appropriate discharge unit value may be determined since the values given in Table 1811.D.5.5A of this code show that the discharge unit value is inversely proportional to the use interval, i.e., if the use interval is doubled, then the discharge unit value is halved. The discharge unit values of all fixtures contributing to flow in a pipe shall be added and the appropriate pipe size (and fall or slope) chosen from Table 1811.D.5.5B of this code for vertical stacks or Table 1811.D.5.5C of this code for the building drain or its horizontal branches.

f. Waste Disposal Units. Special precautions are necessary where kitchen or food waste disposal units are connected to the discharge pipe system. The discharge pipe from such a unit shall connect directly to the main discharge pipe without intermediate connection with any other discharge pipe. Tubular traps shall always be used and any instructions as to installation given by the manufacturer shall be observed. To avoid hot grease being carried into discharge pipes and drains, where it might build up and cause blockage, waste disposal units shall always be automatically flushed with cold water in order to solidify grease before it enters the drainage system.

ventilation pipes may be required (see §1811.D.7 of this code). It may be worthwhile to consider over sizing the discharge pipes to reduce the ventilating pipework required.

Table 1811.D.5.5C			
Maximum Number of Discharge Units <sup>1,2</sup>			
Connected to Building Drain or Building Sewer			
Nominal Internal Diameter of Pipe (in.)	Slope or Fall Per Foot (in.)		
	1/8	1/4	1/2
2	—	10	26
3	40	100	230
4	30	430	1,050
5	780	1,500	3,000
6	2,000	3,500	7,500

NOTES:

- Discharge pipes sized by this method give the minimum size necessary to carry the expected flow load. Separate ventilation pipes may be required (see §1811.D.7 of this code). It may be worthwhile to consider over sizing the discharge pipes to reduce the ventilating pipework required.
- Building sewer sizes start at 4 inches.

6. Design of Pipe Systems for Dwellings. The design of a single stack discharge and ventilating system for dwellings shall conform with the following.

a. General. In dwellings only, the choice and layout of fixtures and their waste pipes may follow the recommendations for simplified systems as provided in this Subsection. Simplified systems for other types of buildings may be possible but are not provided for in this Part.

b. Design of Single Branches and Fittings. The design of single branches and fittings shall comply with the following.

i. Branch discharge waste pipes (fixture drains) serving plumbing fixtures shall have a uniform shallow fall or slope and the inlet to the stack shall be of a sanitary pattern and have a sweep of not less than 1-inch (25.4 mm) radius. Any horizontal change of direction in a fixture drain shall be of long radius and vertical changes of direction are prohibited.

ii. Water closet branch inlets to the stack shall be swept in the direction of flow with a radius at the invert of not less than 2 inches (51 mm). Entries at 45 degrees (0.785 rad) from the vertical are considered equivalent.

Table 1811.D.5.5A		
Plumbing Fixture Discharge Unit Values		
Type Fixture	Intervals between use in minutes	Discharge unit values
Tank Type W.C.	20	15
Sink	25	8
Wash Basin	25	3
Bathtub	75	8
Shower Stall	75	4
Garbage Disposal	25	4
1 fixture group consisting of 1 W.C., 1 Sink, 1 Tub and 1 Lavatory		20

Table 1811.D.5.5B	
Maximum Number of Discharge Units Allowed on Vertical Stacks <sup>1,2</sup>	
Nominal Internal Diameter of Pipe (in.)	Discharge Units
2	20 (No W.C.)
3	200 (No W.C.)
4	850
5	2700
6	6500

NOTES:

- The capacity of a vertical discharge pipe (stack) is limited by the need to preserve a large air core to prevent excessive pressure fluctuation. The flow capacity of a stack may therefore be less than that of a pipe of the same diameter laid at a steep fall.
- Discharge pipes sized by this method give the minimum size necessary to carry the expected flow load. Separate

Table 1811.D.6A		
Design of Single Branches and Fittings		
Component	Design Requirements	Possible Problem
Bend at foot of stack	Bend to be of "large radius", i.e., 6-inch minimum root radius or, if adequate vertical distance is available, two "large radius" 45 bends are to be preferred. Vertical distance between lowest branch connection and invert of drain to be at least 18 inches for a two story house and 30 inches for taller dwellings. Where this distance cannot be achieved, ground floor	Back pressure at lowest branch, foaming of detergents

Table 1811.D.6A Design of Single Branches and Fittings		
Component	Design Requirements	Possible Problem
	fixtures shall be connected directly to the building drain and vented as provided for in other Chapters of this Part (see Figure 1811.D.5.4B of this code).	
W.C. branch connection to stack	Water closet connections shall be swept in the direction of flow with radius at the invert of not less than 2 inches. Fittings in other materials shall have the same sweep as cast iron fittings. The length of unvented water closet is closet branches shall be limited by the diameter of the branch piping: 6 ft for 3-inch diameter, 10 ft for 4-inch diameter.	Induced siphonage at lower level in the stack when water closet is discharged
Lavatory waste 1 1/4-inch trap and 1 1/2-inch minimum waste pipe. Lavatories with 1 1/2-inch P.O. plugs may be installed as provided for sink waste.	"P" traps shall be used. The maximum fall of the waste pipe shall not exceed the hydraulic gradient of the pipe. For the maximum distance between the stack and trap weir see Table 1811.D.6B of this code. Any bends on plan shall be of not less than 3-inch radius at the center line. Waste pipes longer than the recommended maximum length shall be vented. As an alternative, 2-inch diameter waste pipes may be used so long as the hydraulic gradient is not exceeded, but additional maintenance may be necessary to maintain the bore.	Self-siphonage
Bath waste 1 1/2-inch trap and 1 1/2-inch waste pipe	"P" traps shall be used (a 2-inch parallel branch, when required shall not be considered a violation of requirements of other Sections of this Part, when its vertical length does not exceed 12 1/2 inches, and the center line of the parallel branch is not more than 12 1/2 inches from the stack). Owing to the flat bottom of a bath, the trailing discharge normally refills the trap and the risk of self-siphonage is much reduced. Waste pipes 7 ft 6 in. long at a fall or slope of 1/4 in./ft have been used successfully. Position of entry of bath waste into stack to be as shown in Figure 1811.D.5.4A of this Part.	Self-siphonage
Sink Waste 1 1/2-inch trap and 1 1/2-inch waste	"P" traps shall be used. Owing to the flat bottom of a sink, the trailing	Self-siphonage

Table 1811.D.6A Design of Single Branches and Fittings		
Component	Design Requirements	Possible Problem
pipe	discharge normally refills the trap and the risk of self-siphonage is much reduced. Fall or slope of 1/4 in./ft shall be maintained. For maximum length, see Table 1811.D.6B of this code. A sink with 1 1/2-inch tail piece may be drained with a 2-inch horizontal branch not exceeding 8 feet in length. When a 2-inch branch is used, the trap outlet shall connect to a 2 x 1 1/2 inches reducing fitting. An opening into the branch larger than 1 1/2 inches will not be permitted except for a cleanout.	

NOTE:

1. Where the length or fall of the discharge pipe serving a waste fixture is greater than the recommended maximum in this table, the discharge pipe shall preferably be vented (see §1811.D.7 of this code) or a larger diameter discharge pipe shall be used. This may have a maximum length of 10 ft.

Table 1811.D.6B Distance From Trap Weir to Stack or Other Ventilating Pipe	
Minimum Size of Fixture Drain (in.)	Distance Trap to Stack or Vent
1 1/2-inch fixture drains required for lavatories with 1 1/4-inch traps	4 ft 6 in.
1 1/2	5 ft 6 in. (Other than bath waste)
2	7 ft 6 in. (For bathtubs see Table 1811.D.6A of this code)

c. Design of Main Pipework

i. Design details for stacks of various diameters are given below. The choice of design will depend on the space taken up by the pipes and the ease with which they can be accommodated in the building.

ii. An offset in the stack above the topmost connection to the stack has little effect on the performance of the system. Offsets below the topmost connection should be avoided lest extra ventilating pipes be necessary to maintain adequate water seals.

d. 3-Inch Stacks. 3-inch stacks in a single stack system are limited to fixtures other than water closets and to fixtures with maximum drain sizes of 2 inches.

e. 4-Inch Stacks. For details of ventilating pipes see Table 1811.D.6C of this code.

f. 5-Inch Stacks with No Vents (Single Stack System). Suitable for buildings up to 12 stories high where the stack serves one group of fixtures on each floor, or up to

10 stories high where the stack serves up to two groups of fixtures on each floor.

g. 6-Inch Stacks with No Vents (Single Stack System). Suitable for buildings up to at least 20 stories high with not more than two groups of fixtures on each floor.

Table 1811.D.6C Ventilating Pipes Required for Various Loading Conditions 4-inch Discharge Stack		
Number of stories	Stack serving one group on each floor (Each group consists of a water closet, a bath, a basin and a sink. Where dwellings contain more fixtures it may be necessary to provide additional vents)	Stack serving two groups <sup>1</sup> on each floor
Flats (Each complete living unit is on one floor), 1 to 5	No separate venting required	No separate venting required
6-11	2-inch vent stack connected to the discharge stack on alternate floors	2-inch vent stack connected to the discharge stack on alternate floors
12-15	2-inch vent stack connected to the discharge stack on each floor	2-inch vent stack connected to the discharge stack on each floor
16-20	2 1/2-inch vent stack connected to the discharge stack on each floor	3-inch vent stack connected to the discharge stack on each floor
Maisonettes (Each complete living unit occupies space on two floors, with baths on one floor of the unit), 1 to 4	Single stack system	Single stack system
5-8	Single stack system	2-inch vent stack connected to the discharge stack on alternate (bathroom) floors
9-15	2-inch vent stack connected to the discharge stack on alternate (bathroom) floors	2-inch vent stack connected to the discharge stack on alternate (bathroom) floors
16-20	2 1/2-inch vent stack connected to the discharge stack on alternate (bathroom) floors	3-inch vent stack connected to the discharge stack on alternate (bathroom) floors

7. Ventilating Pipes. Ventilating pipes shall comply with the following.

a. General. The purpose of a ventilating pipe is to maintain equilibrium of pressure within the system and thus prevent the destruction of trap seals by siphonage or compression. It will also assist in preventing undue accumulation of foul air by facilitating air movement in the pipe system.

b. Installation. Ventilating pipes shall be so installed that there is a continuous fall back into the discharge pipe system to prevent any possibility of a waterlock or trap preventing the free movement of air through the ventilating

system and to minimize the risk of internal corrosion. Short turn fittings in the pipework shall be avoided.

c. Branch Vents. Branch ventilating pipes may be connected to a main ventilating pipe or be carried upward either individually or in combination with one another. Such connections shall be above the flood level of the highest fixture served.

d. Sizes. The diameter of a branch ventilating pipe or of a ventilating stack shall be as given in Table 1811.D.7 of this code. For extremely long ventilating stacks, a larger diameter pipe shall be used. See Note 1 in Table 1811.D.7 of this code.

e. Arrangement. A branch ventilating pipe, when required, shall be connected to the individual fixture discharge pipe (fixture drain) not less than 3 inches (76 mm) from the crown weir of the trap. A fixture may be connected to the bottom of a fixture vent, or at the base of a main ventilating stack to assure its being kept clear.

f. Purpose. The purpose of the ventilating pipes is to reduce the pressure fluctuations in the discharge stack by allowing air to enter the stack. Where venting is necessary, therefore, it is often convenient to do so by cross connecting the ventilating stack and the discharge stack directly, preferably above the highest fixtures as appropriate. To prevent cross flow into the ventilating stack, the branch ventilating pipe shall slope upward from the discharge stack at an angle of not less than 45 degrees (0.785 rad) from the horizontal until it reaches a point 6 inches (152 mm) above the flood level rim of the highest fixture serving the floor, at which point it may run at a horizontal angle until connecting with the vertical vent.

Table 1811.D.7 Branch Ventilation Pipe or Ventilating Stack	
Diameter of branch discharge pipe or discharge stack, D (in.)	Diameter of Ventilating Pipe (When the vent length exceeds the length of the discharge stack, the vent shall be at least one pipe size larger than required by this table except for individual fixture vents)
Smaller than 3	2/3 D
3 to 4 inclusive	2 in.
Larger than 4	1/2 D

g. Discharge Point. The outlet of every ventilating pipe system to the open air shall be at such a height and position as will effectively prevent the entry of foul air into the building (see §907 of this code).

8. Pipe Chases and Enclosures, Etc. Pipework enclosures, e.g., ducts, casings, etc., shall be of adequate size and shall have access provisions for maintenance, painting, testing and cleaning. They shall be constructed appropriately for fire resistance in accordance with requirements of the applicable codes adopted under the authority of Act 12 of the 2005 First Extraordinary Session.

9. Choice of Materials. Materials shall conform to the applicable requirements of other Sections and Chapters of this code. Fittings used in the construction of single stack



plumbing systems shall in no case be designed with inlet radii less than provided for in this Subsection.

10. Access to Interior of Pipework. Sufficient access shall be provided to enable all pipework to be tested and to provide reasonable access for cleaning and other necessary maintenance. All access points for clearing purposes shall be carefully sited to allow the entry of clearing apparatus or the insertion of testing apparatus and, where these are in ducts, consideration shall be given to the other services accommodated in the duct.

11. Simultaneous Discharge. The system of discharge pipes shall be capable of withstanding satisfactorily the effects of the probable maximum simultaneous discharge of fixtures which will occur in practice. The number of fixtures to be discharged together to simulate this effect is given in Table 1811.D.11 of this code.

a. For example, for a block of flats nine stories high with the stack serving one water closet, one lavatory, one sink and one bath on each floor, the test discharge is one water closet, one lavatory and one sink simultaneously discharged on each floor (i.e., 27 fixtures discharged simultaneously). Where the stack serves two water closets, two lavatories and two sinks on each floor, the test discharge is one water closet, one lavatory and two sinks simultaneously discharged on each floor (i.e., 36 fixtures discharged simultaneously). For the purpose of this test, baths are ignored as their use is spread over a period and consequently they do not add materially to the normal peak flow on which Table 1811.D.11 of this code is based. Where a stack serves baths only, the number to be discharged simultaneously in a discharge should be taken to be the same as for sinks.

b. All traps shall be fully charged and the appropriate combination of fixtures discharged simultaneously. Trap seals shall be measured at the end of the discharge. The worst conditions occur when fixtures on the upper floor are discharged. A reasonable test, therefore, would be to discharge up to one water closet, one lavatory and one sink from the top of the building, distributing any additional fixtures along the stack.

Number of fixtures of each kind on the stack	Water Closet	Wash Basin	Kitchen Sink	Misc. (ea. Type)
1-9	1	1	1	1
10-18	1	1	2	2
19-26	2	2	3	3
27-50	2	3	3	3
51-78	3	4	4	4
79-100	3	5	5	4

i. When the miscellaneous fixture is a washer drain, omit one sink from test for each washer drain, except when washers only are connected to the stack.

ii. For washing machine drains (no washers connected) test shall be conducted with hoses connected to

both the hot and cold water supply out lets and with outlets fully opened. (This is in lieu of discharge from washers.) Test should be of 5 minutes duration, one-half of one cup of liquid detergent shall be dispensed into the washer drain pipe at approximately one-third cup per minute along with the water during the last 3 minutes of each test.

**E. Single Stack Plumbing System.**

1. Approval. The purpose of this Subsection is to make provisions for the design and installation of a single stack plumbing system which is not otherwise allowed in this code. In accord with Chapter 12 of this code, the plumbing official shall require that the owner submit necessary plans and specifications to the state health officer by a Louisiana Registered Professional Engineer registered in either civil or mechanical engineering. In general, single stack plumbing systems may be considered for approval by the state health officer for use on the upper floors of hotel and motel guest rooms but shall not be considered for condominium or apartment complexes.

2. Tests. Single stack plumbing systems shall be tested in accordance with §1205.C of this code.

3. Solvent Single Stack Plumbing System. Copper solvent systems shall be designed and installed in accordance with design criteria contained in the Copper Development Association (CDA) Handbook No. 402/0. Cast iron solvent systems shall be designed and installed in accordance with design criteria contained in ASSE 1043. Cast iron fittings shall meet ASME B16.45. Other materials shall meet standards and specifications listed in Table 703 of this code for drain, waste and vent pipe and fittings.

**F. Appendix References.** Additional provisions for Alternate Designed Plumbing Systems are contained in Figures 6 and 7 of Section 1807 of this code.

**AUTHORITY NOTE:** Promulgated in accordance with R.S. 40:4(A)(7) and R.S. 40:5(2)(3)(7)(9)(16)(17)(20).

**HISTORICAL NOTE:** Promulgated by the Department of Health and Hospitals, Office of Public Health, LR 38:2917 (November 2012).

**§1813. Metric Conversions**

A. For convenience, the following may be used to convert English units of measurement to Metric units of measurement.

Unit of Measure	STARTING WITH the English unit of measurement	MULTIPLY BY	TO GET the Metric unit of measurement
Length	inches	25.4	mm
	ft	0.3048	m
Area	sq in	645.16	mm <sup>2</sup>
	sq ft	0.0929	m <sup>2</sup>
Volume	cu in	0.01639	L
	cu ft	28.3169	L
	gal	3.785	L
Mass	lb	0.4536	kg
Mass/unit length	plf (lb/ft)	1.4882	kg/m
Mass/unit area	psf (lb/sq ft)	4.882	kg/m <sup>2</sup>
Mass density	pcf (lb/cu ft)	16.02	kg/m <sup>3</sup>

PUBLIC HEALTH—SANITARY CODE

Table 1813.A			
Unit of Measure	STARTING WITH the English unit of measurement	MULTIPLY BY	TO GET the Metric unit of measurement
Force	lb	4.4482	N
Force/unit length	plf (lb/ft)	14.5939	N/m
Pressure	psi	6.895	kPa
	psf (lb/sq ft)	47.88	Pa
	in. of Hg @ 60°F	3.37685	kPa
stress, modulus of elasticity	psi	6.895	kPa
	psf (lb/sq ft)	47.88	Pa
Second moment of area	In <sup>4</sup>	416,231	Mm <sup>4</sup>
Section modulus	In <sup>3</sup>	16,387.064	mm <sup>3</sup>
Temperature	°F-32	5/9	°C
	°F + 459.67	5/9	K
Energy, work, quantity of heat	kWh	3.6	MJ
	Btu	1055	J
	ft •lb (force)	1.3558	J
Power	ton (refrig)	3.517	kW
	Btu/s	1.0543	kW
	hp (electric)	745.7	W
	Btu/h	0.2931	W

Table 1813.A			
Unit of Measure	STARTING WITH the English unit of measurement	MULTIPLY BY	TO GET the Metric unit of measurement
Thermal conductance (U value)	Btu/ft <sup>2</sup> • h • °F	5.6783	W/m <sup>2</sup> • K
Thermal resistance (R value)	Ft <sup>2</sup> • h • °F/Btu	0.1761	M <sup>2</sup> • K/W
Flow	gpm	0.0631	L/s
	cfm	0.4719	L/s
Illuminance	foot-candle (lm/sq ft)	10.76	lx (lux)
Velocity (speed)	mph	0.447	m/s
Plane angle	°(angle)	0.01745	rad

AUTHORITY NOTE: Promulgated in accordance with R.S. 40:4(A)(7) and R.S. 40:5(2)(3)(7)(9)(16)(17)(20).

HISTORICAL NOTE: Promulgated by the Department of Health and Hospitals, Office of Public Health, LR 38:2924 (November 2012).

# INDEX

- Abandoned grease traps, 1005.N.4.n
- Above ground piping, 619.B,  
703.C, 903.C, 1103.A
- Accessibility,
  - backwater valves, 705.E
  - cleanout plugs, 717.C, 717.D, 717.E, 717.F
  - expansion joints, 315.F
  - floor drains, 1001.D
  - interceptor, 1005.H
  - single stack system, 1811.D.3.g
  - slip joints, 401.C, 401.D
  - water heaters, 501.E
- Acid, soil & waste piping,  
703.F, 709.F
  - system vent, 903.C, 903.D
- Administration, Chapter 1
  - enforcement, 117, 121
  - inspections and tests, 133, 319, 319.D,  
1205, 1515.N, 1613.N, 609.F.9
  - permits, 123, 131
- Air break (drainage system),  
defined, 203
  - indirect waste, 805.B
- Air chamber, 611.I
- Air gap (drainage system),  
defined, 203
  - indirect waste, 805.A
- Air gap (water distribution)  
defined, 203, 609.F.2,  
cross connection control, 609.A, 609.F.3
- Airlock, 1503.A
- Alterations and repairs, 301.C
- Alternate designed plumbing systems,  
Chapter 12
- Alternate materials and methods, 129
- Anchors, hangers and supports, 317
- Anti-siphon devices, 511.A
- Approved, defined, 203
- Approved materials, 407, 603, 613, 619, 703
- Area drain, defined, 203
- Asbestos cement pipe, 1101.E
- Attachment, hangers and anchors, 317
  - horizontal piping, 317.C
  - vertical piping, 317.B
- Automatic flush valves, 415.N.5
- Automatic flushing tank, 415.L.1
- Auxiliary pressure, supplementary tank, 611.F
  
- Back-siphonage, 203, 609, 609.A.2
- Back-to-back fixtures, 925.C
- Backfill, material, 705.H
  - trenching and excavation, 307, 705.H.1
- Backfilling, 307.D
- Backflow, 203, 609, 609.A.1
  - air gap preventer for, 609, 609.F.2
  - cross connection, defined, 203, 609.F.2
  - defined, 203, 609.F.2
  - device testing, 319.F
  - preventer, 203, 609, 609.F.2
- Backwater valve, 1101.E, 1101.H, 705.G, 415.E.1.c
- Bar and soda fountain sink traps, 911
- Baskets and strainers, 807.G.2, 415.D, 1005.N.9
- Bathrooms, venting for double, 919.B
  - venting for multistory groups, 919.C
  - venting for one, 921
  - venting for single groups, 919.A
- Battery fixtures, defined, 203
- Battery venting, 925.A, 937.C, Table 937.C
- Boiler blow-off, defined, 203
- Borosilicate glass pipe and fittings. 303.G.6.b, 317.B.7,  
317.C.7, 703.C.1, 703.D, 703.F, 709.F
- Bottling plants, 1005.J.2
- Branch, defined, 203
  - fixture, 203
  - gradients, single stack systems, 917
  - horizontal, 203, 923.A
  - interval, defined, 203
  - vent, defined, 203
- Brazed joints, 621.D
- Brazing or welding, 315.D
- Building, defined, 203
  - other than dwelling, 617.D
  - storm sewer, 203, 1103.D
  - subdrain, 203, 1101.E
  - trap (house), defined, 203
- Building drain system, Chapter 7
  - above-ground piping within building, 703.C
  - below sewers, 731.A
  - defined, 203
  - materials, 703
  - piping in raceways or tunnels, 703.C
  - sizing, 725
  - underground piping within Buildings, 703.D
- Building sewer, 705
  - cleanouts, 705.E, 717.B
  - defined, 203
  - materials, 703
  - sizing, 725
  - test, 319.D
- Building storm drains, defined, 203
  - size, Table 1111.A, Table 1111.B
  - materials, 1103
- Building classification, defined, 203
- Burned lead joints, 313.G
- Bushings, soldering, 303.G.4
  
- Calculation of size of water,  
distribution system, 611
- Cast iron soil pipe, 303.G.1, 313, 711.C, 317.B.2
  - base support, 317.B.2
  - elastomeric compression gasket, 709.D
  - hangers 317.B.2, 317.C.2
  - joints, 315.A, 315.B
  - no-hub, 709.E
  - support intervals, 317.B.2
- Cast iron water pipe, 603, 613, 613.B, 619

- Caulked joints, 709.B
- Caulking ferrules, 303.G.3
- Cement mortar joints, 313.F
- Change in direction, 311.A
- Character of water, 601.C
- Circuit and loop venting, 925, 937.C,
  - Table 937.B
- Circuit vent, 203, 937.C
- Circular-type sink, 415.H.1
- Clay pipe, 703, 705.A, 705.H.2, 1103.D
- Clay sewer pipe joints, 711.A
- Cleaning, indirect waste pipe, 809.B
  - plumbing fixtures, 403.A
- Cleanout, 303.G.6, 717.F, 717
  - accessibility, 717.D, 717.E
  - clearances, 721
  - size, 719
- Cleanouts on building sewers, 705.E
- Clear-water wastes, 807.H
- Clearances, cleanout, 721
- Close-coupled tanks, 415.N.4
- Code, remedial, 109
- Color code, 607
- Combination waste & vent system,
  - defined, 203, 1811.C
- Combination compartment, defined, 1503.A
- Combination fixture, defined, 203
- Combining storm with sanitary drainage, 1107.B
- Commercial, building grease traps/interceptors,
  - 1005.D, 1005.N
  - dishwashing machine, 807.B
  - grinders, 415.F.2, 1005.K.1
  - installations-interceptors, 1005.A, 1005.N
  - type grinders-food wastes, 415.F.2, 1005.K.1
- Common vent, 203, 915, 915.B
- Concealed piping, 717.C
- Concrete sewer pipe, 703, 711.B
- Condemned equipment, 301.H
- Condensers and sumps, 731, 807.I, 807.C.2,
  - 1101.E, 1101.F, 1101.G
- Conductor, defined, 203
  - inside, 1103.A
  - pipes prohibited, 1107.B, 1107.C
  - protection of, 1107.A
- Conductors and connections, 1107
- Connection, to plumbing system required, 301.J
  - backflow, defined, 203, 609.F.2
  - drainage system, 731.H
  - fittings prohibited, 311.C
  - indirect waste, 807.C
  - plumbing fixtures, 413.D.2, 401.C
  - sumps and ejectors, 731
  - vent, 909, 925.B, 935
  - water heater, 509, 601.D
- Continuous flow valves, 723.C
- Continuous vent, defined, 203
- Continuous waste, defined, 203
- Controls of water supply, 617
- Copper, DWV drainage tube, 703, 903
  - sheet, 303.G.2
  - tube, 317.B.4, 317.C.4
  - tubing to threaded pipe joints, 619.H.1
  - water tube, 603, 613, 619, 621.F
- Corrosion and breakage, 305.A
- Cross connection, 203, 609
  - containment practices, 609.F.5
  - control surveyor, 607.C
  - fixture isolation practices, 609.F.6
- Cross flow, prevention, single stack systems, 1811.D.5.d
- Crown vent, 913.D
- Cutting or notching, 309.B
  
- Damage to drainage system or public sewer, 701.B
- Dead end, defined, 203
- Defective plumbing test, 319
- Definitions, Chapter 2, 513.B, 609.F.2
  - for backflow control, 609.F.2
  - for mobile homes, 1503.A, 1603.A
- Demand loads, 725
- Developed length, defined, 203
- Devices-energy shutoff, 511.D
- Direction of flow, 717.D
- Discharge, food waste grinders, 1005.K.1
  - garbage can washers, 415.D
  - single stack systems, 1811.E
- Dishwashing machine, 415.A, 415.B
- Disinfection of potable water system piping, 601.B
- Disposal units, 415.F
- Distance, fixture trap from vent, 913, Table 913.A
  - trap to fixture, 1001.I
  - trap to stack, single stack systems, Table 1811.D.6B
- Distribution of water supply, Chapter 6
- Double bath, 919.B
- Double offset, defined, 203
- Double trapping, 1001.F
- Downspout or interior leader test, 319.E
- Downspout, defined, 203
- Drain and sewer combination, 1107.B
- Drain and sewers, building, 725.A
- Drain and water connections, 415.J.1
- Drain, 203, 615.G
  - building below sewers, 731.A
  - building, 203, Chapter 7, Chapter 10
  - cock, 625.A
  - fixture, 203, 1003
  - floor, 415.E, 731, 1107.C
  - hose, 1503.A, 1519.B
  - roof, 203, 1109
  - sediment, 501.D
  - storm, 203, 1101
- Drainage, below sewer level, 301.I
  - materials, 703, 1103, 1109.A
  - pipe installations, 707
  - required, storm, 1101.B
  - requirements, 703.A
  - system, defined, 203
  - vent system test, 319
- Drainage piping, defined, 203
  - offset, 727
  - underground, 725.D
- Drainage system, sizing, 725

Drainage system, Chapter 7  
   building sewer, 705  
   connections, 731.H  
   determination of sizes, 725  
   drainage piping installation, 707  
   fittings or connections, 315, 711  
   fixture units, 723  
   floor drains, 415.E  
   frost protection, 301.B.23  
   materials, 703  
   offsets in drainage piping, 727  
   sizing, 725  
   sumps and ejectors, 731  
   unions, 1001.G  
 Drains and storm sewers combined, 1107.B  
 Drinking fountains, 415.C, 807.J  
   design and construction, 415.C  
   protection of water supply, 415.C.2  
 Drips, 807.E  
 Drum traps, 1003.D  
 Duplex equipment, 731.E  
 Durham system, defined, 203  
 DWV copper drainage tube, 703, 903, 1103

Effective opening, defined, 203  
 Ejectors and sumps, 731  
 Elastomeric compression gasket joints, 709.D  
 Energy shutoff devices, 511.D  
 Equipment, condemned, 301.H  
   used or second hand, 301.G  
   water heating, 301.B.3, Chapter 5  
   water pumping and storage, 615  
 Excavations, backfill and trenching, 307  
 Existing buildings, 113, 301.C, 411.A  
 Existing work, defined, 203  
 Expansion joints, 315.F, 1101.D  
 Extensions through wall, 907.F  
 Exterior openings, 301.F

Final Test, 319, 1205  
 Fines, 117, 137  
 Fittings, 311  
   and sewer pipe, 703  
   drainage system, 703.E  
   or connections prohibited, 715.B  
   supply, 603  
   vent, 903.E  
 Fixture drain, defined, 203  
   type and size, 1003  
 Fixture outlets, and strainers, 413.C  
   minimum pressure, 611.E  
 Fixture overflow, 413.D  
 Fixture trap, 1001.H  
   distance to vent, 913.A  
   vents for, 917  
 Fixture unit, 203, 723  
 Flow rate, defined, 203  
   per fixture or group, Table 723.A  
 Fixtures and connections prohibited, 401.B  
 Fixtures back-to-back, in battery, 925.C  
 Fixtures, Chapter 4

  at different levels, 917.B  
   branch, 203, 611.C, 725  
   combination, defined, 203  
   not listed, Table 723.B  
   plumbing, Chapter 4  
   quality of, 407  
   setting, 403.D  
   values for, 723.A  
   vents, 913  
 Flag poling, 907.D  
 Flared joints, 621.C  
 Flashing for roof drains, 1109.D  
 Flashing for vent terminals, 907.C  
 Flat decks, 1109.C  
 Float valves, 415.N.3  
 Flood, level rim, defined, 203  
 Floor drains, 415.E, 731  
   must be trapped, 1107.C  
   public restrooms, 415.E.2  
   size, Table 723.A  
 Floor flanges, 303.G.5  
 Flow, direction, 717.D  
   obstruction, 311.F  
 Flush valve, defined, 203  
 Flush valve-automatic, 415.L.1  
 Flusometer valve, defined, 203  
 Food waste grinder units, 415.F  
   commercial, 1005.K  
   discharge, 1005.N.3.c  
 Food grinder, 415.F, 1005.N.3.c  
 Food handling, 807.A  
 Freezing, 305.D  
 Frost, closure, 907.B  
   protection, 301.B.23  
 Frostproof closet, defined, 203  
 Future fixtures, 725.C

Garbage can washers, 415.D  
 Grade, 203, 909.A  
   connections for vents, 909  
   horizontal drainage piping, 707.A  
 Gravity and suction tanks, 615.H  
 Grease interceptor, 1005, 1005.N  
   defined, 203, 1005.N  
   garbage can washer, 415.D  
 Grease trap, defined, 203, 1005.N  
 Grinders, commercial-type, 415.F.2  
   food waste, commercial, 1005.K.1  
   food waste, sinks waste outlets, 413.B  
   food waste, units, 415.F  
 Ground joint brass connections, 621.H.2

Hangers and anchors, 203, 317  
 Hangers and supports, Chapter 3  
   base of stacks, 317.E  
   defined, 203  
   general, 317.A  
   horizontal piping, 317.C  
   repair or replacement, 317.D  
   strains and stresses, 317.A.1  
   vertical piping, 317.B

- Header vent, 935
- Health and safety, 301.D
- Heel or side inlet bend, 311.D
- Historic buildings, 115
- Horizontal branch, 203, 923.A
- Horizontal drainage, piping, 707.A, 707.B, 707.C
- Horizontal fixture branches and stacks, Table 725.A.2
- Horizontal pipe, defined, 203
- Horizontal piping supports, 317.C.1
- Horizontal piping, 317.C
- Horizontal storm drain size, 1111.B
- Hospital plumbing systems, 1301
- Hot water, distribution piping, 601.D
  - for dishwasher, 415.A, 415.B
  - supply, 601.D
- House drain, defined, 203
- House sewer, defined, 203
- House trap, defined, 203
- Hydraulic gradient, 917.A
  
- Identification, of materials, 303.D
- Identification, of piping, 607
- Improper location of piping and fixtures, 405.B
- Increasesers and reducers, 311.G
- Independent mobile home or travel trailer, 1503
- Indirect waste pipe, 203, 807
  - cleaning, 809.B
  - connections, 807.C
  - material and size, 803
- Indirect waste piping & special wastes, Chapter 8
  - air break, 805
  - air gap, 805
  - backflow preventer, 805
  - clear water wastes, 807.H
  - condensers & sumps, 807.I
  - drinking fountains, 807.J
  - indirect waste piping, 807
  - length, 809
  - material & size, 803
  - receptors, 807.G
  - swimming pools, 807.K
- Individual fixture reventing, 923
- Individual or private sewage disposal system, 203, 701.C
- Individual relief & circuit & loop vents, 925, 929
- Individual vent size, 937.B, 937.C
- Individual vent, 203, 915.A
- Individual venting required, 923.B
- Industrial wastes, defined, 203
- Inlet coupling, 1503
- Inside conductors, 1103.A
- Inspector, plumbing, defined, 203
- Installation, plumbing fixtures, 403
  - unsafe, 125
  - vent stacks, 905.A
  - waste receptors, 807.G.1
- Intercepting devices, 1005.J.1.b
- Interceptor, approval, 1005.A, 1005.N
  - commercial, 1005.J.1
  - defined, 203
  - laundry, 1005.J.1.a, 1005.N
  - maintenance, 1005.L, 1005.N
  - oil, 1005.E, 1005.N
  - required, 1005, 1005.N
  - sand, 1005.F, 1005.N
  - separators, 1005
  - approval, 1005
  - slaughter houses, 1005.J.3, 1005.N
  - water connection, 1005.I
- Interceptors-separators, accessibility of
  - interceptors, 1001.H
  - backwater valves, 705.G
  - bottling establishments, 1005.J.2, 1005.N
  - commercial grinders, 1005.K
  - grease interceptors, 1005.D, 1005.N
  - interceptors & separators, 1005, 1005.N
  - laundries, 1005.J.1, 1005.N
  - maintenance, 1005.L, 1005.N
  - oil separators, 1005.E, 1005.N
  - sand interceptors, 1005.F, 1005.N
  - slaughter houses, 1005.J.3, 1005.N
  - venting interceptors, 1005.G
- Interceptors-separators, Chapter 10, 1005.N
- Interior leader or downspout test, 137, 319.E
- Interior openings, 301.F.1
- Intermediate waste holding tank, 1503
  
- Joints and connections, General 315
  - increasers & reducers, 311.G
  - prohibited joints & connections, 715
  - sanitary drainage, 709
  - special joints, 621.H
  - tightness, 313.A
  - type of joints, 313, 621, 715
  - unions, 1001.G
  - use of joints, 315, 715
  - water closets, ped. urinal & trap, 713
  - water supply, 621
- Joints, borosilicate glass joints, 709.F
  - brazed, 621.D
  - burned lead, 313.G
  - caulked, 709.B
  - cement mortar, 313.F
  - elastomeric compression gasket for
    - cast iron soil pipe, 709.D
  - expansion, 315.F
  - flared, 621.C
  - hubless cast iron soil pipe system, 709.E
  - plumbing fixtures, 403.B
  - precast, 313.E
  - slip, 315.E, 401.C, 401.D
  - soldered, 621.B
  - solvent cement joints for plastic
    - pipe and fittings, 313.H
  - special, 621.H
  - threaded, 313.B
  - tightness of, 313.A
  - types, 315, 621, 713
  - wiped, 313.C
- Kitchen sink-waste stack, 729
- Large pipe, cleanout, 721.B

- underground, 719.B
- Large piping horizontal drainage, 707.C
- Laundry, interceptors, 1005.J.1.1, 1005.N
  - tray, waste outlet, 415.G.1
- Lavatory, 413.A, 611
  - self-closing metering, 409.A.3
  - waste outlet, 413.A
  - water usage, 409
- Lead, 303.G.1
  - pipe, 317.B.5
  - to cast-iron or steel, 315.B
- Lead free, defined, 203
  - joints, 621
  - special materials, 303.G.1
  - water piping quality, 303.F, 613.A, 619.A.3
- Leader, defined, 203
  - storm drain size, 1111
- Length, indirect waste piping, 809
  - trailer or mobile home, 1503
  - vent stacks, 937.A
  - vent, 937
- Liability, Chapter 1, 131, 137
- Light and ventilation, 405.A
- Line valves, 625.B
- Liquid waste, defined, 203
- Load factor, defined, 203
- Loop and circuit venting, 925
- Loop vent, defined, 203, 937.C
- Low pressure cutoff, 607.G
  
- Main, defined, 203
- Main sewer, defined, 203
- Main stack, 905.C
- Main vent, 203, 905.C
- Main vents connect at base, 933
- Maintenance, interceptors, 1005.L
  - mobile home park, 1621
  - plumbing fixtures, 111.E
  - travel trailer park, 1521
- Mandatory water supply, 301.K
- Manhole covers, 717.G
- Materials, approved, 303, 603, 703
  - backwater valves, 705.G
  - design of pipe cleanouts, 717.A
  - drainage system, 703
  - hangers and anchors, 317
  - labor for tests, 133
  - mobile home parks, 1609
  - plumbing fixtures, Chapter 4
  - plumbing installations, 303, 603, 703
  - quality and weight, 303
  - roof drains, 1109.A
  - specific type drainage, 703.B
  - specific type vents, 903.B
  - specifications, 303.C
  - sterile, 807.D
  - storm drain, 1103
  - travel trailer parks, 1511
  - vents and venting, 903
  - water distribution pipe, tubing & fittings, 619
  - water service pipe, 613
- May, defined, 203
- Mechanical excavation, 307.C
- Minimum, size of fixture-supply pipe, 607.C
  - size of soil & waste stacks, 725.B
  - size of water distribution system, 607.A
- facilities, 411
- pressure at fixture outlets, 607.E
- standards, 303.A
- velocity, 705.D
- Mobile home, 1603
  - connections-responsibility, 1617
  - of travel trailer park, 1519, 1521
- Multiple wash sinks, 415.H
- Multistory bathroom groups, 411.A.7, 919.C
  
- Noise and hazard, 607.I
- Nonpotable water, 203, 607.B
- Nonwater Urinals, 409.A.2
- Notching or cutting, 309.B
- Nuisance, defined, 203
  
- Obstruction to flow, 311.F
- Offset, defined, 203
  - double, 203
  - drainage piping, 727
  - of 45 degrees or less, 727.A
  - reliefs for vents, 931.C
  - return, defined, 203
  - vents, 931
- Offsets, above highest branch, 727.B
  - less than 45° from horizontal
  - in buildings five or more stories, 931
  - below lowest branch, 727.C
  - more than 45 degrees, 727.D
- Oil separators, 1005.E, 1005.N
- Old house sewers and drains, 705.D
- Open trenches, 307.B
- Openings, exterior, 301.F
  - interior, 301.F.1
- Overflow, 413.D
  - fixture, 413.D
  - laundry tray, 415.G
- Parks, mobile homes and travel trailers, 1503
- Penalties and violations, 137
- Permit, 131
  - failure to obtain, 131
  - fees, Appendix H
- Person, defined, 203
- Pipe capacities, single stack systems, 1811.D.5.e
- Pipe cleanouts, concealed piping, 717.C
  - direction of flow, 717.D
  - large pipe, 721.B
  - location, 717.B
  - material and design, 717.A
  - new fixtures prohibited, 717.E
  - size, 719
- Pipe, asbestos cement, 1101.E
  - borosilicate pipe and fittings, 303.G.6.b, 317.B.7, 317.C.7
  - cast iron soil pipe, 317.B.2, 807
  - horizontal, 317.C
  - large, 719.B, 721.B

- lead, 317.B.5, 317.C.5
- plastic pipe and fittings, 303.H, 603, 703, 903
- protection, 305
- small, 719.A, 721.A
- waste, defined, 203
- Pipes through footings or foundation walls, 305.C
- Piping, close to footings, 305.E
- Piping, concealed, 717.C
  - horizontal, 317.C
  - identification, 607
  - in concrete, 317.E
  - material, 303, 603, 703
  - small, 707.B
  - subject to freezing, 305.D, 301.B.23
  - support of, 307.A
  - vertical, 317.B
- Pitch or grade, defined, 203
- Plans and specifications, 1507, 1607,
  - 1203.1, 1809.A.3, 1005.N.2.c
- Plastic, pipe & fittings, 303.H
  - materials, 303, 603, 703
- Plumber, responsibility, 131, 137
- Plumbing fixture, Chapter 4
  - alternate materials, 129
  - cleaning, 403.A
  - connection, 413.D.2
  - defined, 203
  - dishwashing machine, 415.A, 415.B
  - drinking fountain, 415.C
  - floor drains, 415.E
  - food waste grinder units, 415.F
  - garbage-can washers, 415.D
  - installation, 403
  - joints, 403.B
  - laundry trays, 415.G
  - lavatories, 413.A
  - minimum facilities, 411
  - multiple wash sinks, 415.H
  - overflows, 413.D
  - prohibited fixtures & connections, 401.B
  - requirements, 407
  - shower receptors & compartments, 415.I
  - sinks, 413.B
  - special fixtures & specialties, 415.J
  - strainers & fixture outlets, 413.C
  - urinals, 415.L
  - washing machines for residences, 415.M
  - water closets, 415.N
- Plumbing installation,
  - hot water storage, Chapter 5
  - materials, 303, 603, 703
  - standards for mobile homes and mobile home parks, 1601
  - standards for travel trailers and parks, 1501
- Plumbing official, 203
  - powers and duties, 117
  - qualifications, 203
- Plumbing system,
  - connection required, 301.J
  - defined, 203
- Plumbing, defined, 203
- Pneumatic ejectors, 929
- Pool, swimming, 807.K
- Potable water,
  - acceptable sources, 605.B
  - defined, 203
  - supply protection, 609
  - system piping disinfection, 601.B
- Power & duties of plumbing official, 117
- Precast joints, 313.E
- Pressure, marking of storage tank, 501.F.2
  - variable street, 607.H
  - minimum, 607.E
- Pressure relief valves, 511.C
- Pressure tanks, 615.I
- Pressure tanks, boilers & relief valves, 615.B
- Privacy screens, 301.B.20, 415.L.5, 415.N.7, 1509.E
- Private or private use, defined, 203
- Private sewage disposal system, 701.C, Chapter 17
- Private sewer, defined, 203
- Private water supply, 613.F
- Processing, water used for, 625.C
- Prohibited fixtures, 401.B
- Protected traps, 901.B
- Protection, of trap seals, 901.B, 913.B
  - conductors, 1107.A
  - dishwashing machines, 415.A, 415.B
  - pipes, 305
  - potable water supply, 609
  - washing machines, 415.M.1
  - water supply, 609
- Public institutional showers, 415.I.3
- Public or public use, defined, 203
- Public sewer, defined, 203
- Pumps and other appliances, 615.A
  
- Quality of fixtures, 407
- Quality of water supply, 605
  
- Rainwater conductor protection, 1107.A
- Receptors, 807.G
- Records, 609.F.9.d.iv
- Reducers and increasers, 311.G
- Reducing valve or regulators for water pressure, 607.J
- Relief vent, 929
  - defined, 203
  - interceptor, 1005
  - size, 937.B
- Relief, outlet wastes, 511.F
- Relief valves, water pressure and temperature, 511.C
- Remedial code, 109
- Repairs, alterations, 301.C
- Reports, 133, 1203.2
- Retesting, 133
- Return offset, defined, 203
- Revent pipe, defined, 203
- Reventing individual fixtures, 923
- Revocation of permits, 123
- Right of entry, 119
- Rise, vertical, 909.B
- Riser, defined, 203
- Rodent proofing, 301.F



- Roof drain, 1109
  - defined, 203
  - flashings, 1109.D
  - flat decks, 1109.C
  - materials, 1109.A
  - strainers, 1109.B
- Roof, extensions, 907.A
- Safety devices, 511, 623
- Safety, water heater, 501.F.1
- Sand interceptor, 203, 1005.F, 1005.N
- Sanitary and storm sewer, combined, 1107.B
  - separated, 705.C
- Sanitary sewer, defined, 203
- Scald Prevention, 623
  - bathtub and whirlpool, 623.C
  - gang showers, 623.A.1
  - individual showers, 623.A.2
  - public lavatory, 623.B
- Seal loss, single stack systems, 1811.D.3
- Seats, water closet, 415.N.6
- Sediment drains, 501.D
- Self-closing metered faucets, 409.A.3
- Separate connections-domestic disposal units, 415.F.1
- Separate controls for each family unit, 617.C
- Separate trap washing machine, 415.M.2
- Separate trenches, 705.A
- Separate venting, 931.B
- Separate vents, 731.G
- Separator, defined, 203, 1005.N
  - interceptors, 1005, 1005.N
  - slaughter house, 1005.J.3, 1005.N
- Septic tank, 203
- Service buildings, 1503, 1509, 1619
- Service lines near drain or sewer lines, 613.C
- Sewage, defined, 203
- Sewer and drain combination, 1107.B
- Sewer pipe,
  - cast iron soil pipe, 303, 703
  - clay, 711.A
  - concrete, 711.B
  - joints, 709.C
  - plastic, 313.H, 317.B.6, 317.C.6, 703
- Sewer, & water pipes, 307.F
  - building, 203, 705
  - house, defined, 203
  - in filled ground, 705.B
  - lateral, 1503
  - main, defined, 203
  - public, defined, 203
  - storm, 203, 1103.D Shall, defined, 203
- Shower, 415.I
  - compartment floor construction, 415.I.2
  - heads, 409
  - public or institutional, 415.I.3
  - receptors and compartments, 415.I
- Side inlet or heel bend, 311.D
- Side vent, defined, 203
- Single stack discharge & ventilating
  - pipe systems, 1811.D, 1811.E
- Single stack plumbing systems, 1811.E
- Sinks, 413.B
  - bar and fountain sink traps, 911
  - circular type, 415.H.1
  - kitchen, waste stack, 729
  - multiple wash, 415.H
  - straight-line type, 415.H.2
  - traps for bars and fountains, 911
  - waste outlet, 413.B
- Sizing, of water distribution system, 619, 611, 1805
  - drainage system, 725
  - pipe, 1805.D
  - vents, 937
- Slaughter house, separators, 1005.J.3, 1005.N
- Sleeves, 305.B
- Slip joints, 203, 315.E, 401.C
- Slope, defined, 203
- Small pipe cleanouts, 719.A, 721.A
- Small piping horizontal drainage, 707.B
- Soil pipe, defined, 203
- Solar Water Heating Systems, 513
- Soldered joints, 621.B
- Soldering bushings, 303.G.4
- Special fixtures and specialties, 415.J
- Special joints, 621.H
- Special materials, 303.G
- Special type separators, 1005.M
- Special waste pipe, defined, 203
- Specifications, and drawings,
  - and plans, 1507, 1607, 1203.1, 1809.A.3, 1005.N.2.c
  - for materials, 303.C
- Splashing, 807.G.3
- Sprinklers (lawn), 609.C.3
- Stack, defined, 203
  - group, defined, 203
  - main, 905.C
  - of more than 10 branch intervals, 929
  - vent, defined, 203
  - venting, 203, 921
- Standards, minimum, 303.A, 111.D
- State Health Officer, 203
- Sterile materials, 807.D
- Stop and waste valve combination, 613.E
- Storm drain, Chapter 11
  - building size, 1111.B
  - conductors and connections, 1107
  - defined, 203
  - general, 1101
  - materials, 1103
  - roof drains, 1109
  - size of leaders and storm drains, 1111
  - underground, 1103.C
  - values for continuous flow, 1115
- Storm and sanitary drainage combination, 1107.B
- Storm sewer, building, 203, 1103.D
- Straight-line type sink, 415.H.2
- Strain and stresses, 317.E
- Strainers, 1109.B
  - and baskets, 807.G.2
  - and fixture outlets, 413.C
- Structural safety, 309

Subdrain, building, 203, 1101.E  
 Subsoil drain, 203, 1101.D  
 Suction and gravity tanks, 615.H  
 Sump, and ejector connections, 731.K  
   pump equipment design, 731.C  
   condensers, 807.I  
   defined, 203  
 Supplementary tank, auxiliary pressure, 607.F  
 Supply fittings, 601.F  
 Supports, base of stacks, 317.E, 1811.D.3.f  
   buried piping, 307.A  
   defined, 203  
   horizontal piping, 317.C.1  
   single stack systems, 1811.D.3.f  
 Swimming pools, 415.K, 807.K  
  
 Tables: battery vent sizing, 937.C  
   building drains and sewers, 725.A.1  
   distance of fixture trap from vent, 913.A  
   fixture units per fixture or group, 723.A  
   fixtures not listed, 723.B  
   horizontal fixture branches and stacks, 725.B  
   materials for plumbing installation, 303, 603, 703  
   minimum facilities & occupant content, 411  
   size and length of vents, 937.B  
   size of horizontal storm drains, 1111.B  
   size of vent stacks, 919.C  
   size of vertical leaders, 1108.A  
 Tanks, close-coupled, 415.N.4  
   controls, 617.B  
 Tests,  
   backflow devices, 319.F  
   final, 133, 319, 319.F, 1205, 1515.N, 1613.N, 609.F.9  
   interior leaders or downspouts, 319.E, 1101.I  
   material and labor for, 319.A  
   methods for drainage and vent systems, 319.B  
   of building sewer, 319.D  
   of drainage and vent systems, 319.B,  
     701.D, 901.C, 1515.N, 1613.N  
   engineered stack systems, 1205  
   water supply system, 319.C, 601.E  
 Threaded joints, 313.B  
 Threaded pipe to cast iron, 315.A  
 Threaded pipe, 317.B.3, 317.C.3  
 Threaded unions, 1001.G  
 Tightness of joints, 313.A  
 Trailer length, 1503  
 Trap, and strainers-floor drain, 415.E.1.d  
   anti-siphon, 511.A  
   cleanouts, 717.F  
   dip, 913.C  
   drum, 1003.D  
   fixture, 1001.H  
   function, single stack systems, 1811.D.3  
   grease, defined, 203  
   house, defined, 203  
   level and protection, 1001.C  
   main, 1001.A  
   prohibited, 1001.E  
   protected, 901.B  
   relation to fixture drains, 1003.B  
   seal protection, 415.E.4, 901.B, 913.B  
   seal, 203, 1001.B  
   single stack systems, 1811.D.4  
   size for individual conductors, Chapter 11  
   size, 1003.A  
   storm drain, 1101.C  
   to fixture, distance, 1001.I  
   to vent distance, 915.A, 915.C  
   types, 1003.C  
   underground, 1001.D  
 Trapping, double, 1001.F  
 Traps and cleanouts, 717, 719, 721, Chapter 10  
   cleanout clearances, 721  
   distance of trap to fixture, 1001.I  
   general requirements, 1001  
   pipe cleanouts, 717  
   size of cleanouts, 719  
   type & size of traps & fixture drains, 1003  
 Travel trailer, defined, 1503  
   park, defined, 1503  
   sanitary service station, defined, 1503  
 Trenching, excavation, backfill, 307  
 Trough Urinals, 401.B, Table 411-Footnote 15, 415.L.4  
  
 Underground, drainage piping, 725.D  
   piping within buildings, 703.D  
   storm drains, 1103.B  
   traps, 1001.D  
   vent piping, 903.D  
   trough urinals, 401.B  
 Unions (threaded), 1001.G  
 Unit load-maximum fixture, 725.A  
 Unsafe installations, 125  
 Urinals, 407, 411, 415.L  
   equipped with automatic flush valves, 415.L.2  
   nonwater, 409.A.2  
   trough, 401.B, Table 411-Footnote 15  
 Used or secondhand equipment, 301.G  
 Used piping, 601.C.2  
  
 Vacuum breakers, defined, 203  
 Values for continuous flow, 723.C  
 Values for fixtures, 723.A, Table 723.A  
 Valves, backwater, 415.E.1.c, 705.G, 1101.E, 1101.H  
 Valves, float, 415.N.3  
   flush, defined, 203  
   flushometer, defined, 203  
   line, 625.B  
   stop-and-waste valves and devices, 613.E  
 Variable street pressures, 607.H  
 Velocity, minimum, 705.D  
 Vent connections, 909  
   circuit and loop, 925  
   stack, 935  
 Vent offset, 931  
   relief, 931.C  
 Vent piping, above ground, 903.C  
   single stack systems, 1811.D  
   size building sump, 731.F  
   underground, 903.D  
 Vent relief, 929

- defined, 203
- installation, 905.A
- length, 937.A
- minimum size, 725.B
- multistory bathroom, Table 919.C
- Vent system, and drainage test, 319
  - defined, 203
- Vent terminals, 907, 907.F
  - extensions through wall, 907.F
  - flashings, 907.C
  - frost closure, 907.B
  - location, 907.E
- Vent stack, 905.B
- Vent, battery, 937.C
  - branch, defined, 203
  - circuit, defined, 203
  - common, defined, 203
  - continuous, defined, 203
  - crown, 913.D
  - fittings, 903.E
  - fixture, 915
  - flashings, 907.C
  - grades and connections, 909
  - headers, 935
  - height above fixtures, 909.C
  - individual, 203, 915.A, 937.B
  - length, 937
  - loop, 203, 925
  - main to connect at base, 933
  - main, 203, 905.C
  - materials, 903
  - pipe, defined, 203
  - separate, 731.G
  - side, defined, 203
  - sizes building sump, 731.F
  - sizing, 937
  - wet, 203, 919
  - yoke, defined, 203
- Ventilation and light, 405.A
- Venting, battery, 925.A
  - circuit and loop, 925
  - fixture traps-different levels, 917.B
  - interceptors, 1005.G
  - separate, 931.B
  - stack, 203, 921
- Vents and venting, Chapter 9
  - bar and fountain sink traps, 911
  - circuit and loop, 925
  - common vent, 203, 915
  - fixture vent, 913
  - frost closure, 907.B
  - individual fixture reventing, 923
  - main vents to connect at base, 933
  - materials, 903
  - offsets at an angle less than 45°, 931
  - pneumatic ejectors, 929
  - protection of trap seals, 901.B
  - relief vents, 929
  - size and length of vents, 937
  - stack, 921
  - vent grades and connections, 909
  - vent headers, 935
  - vent stacks, 905
  - vent terminals, 907
  - vents for fixture trap, 917
  - wet venting, 919
- Vertical leader size, 1108.A
- Vertical pipe, defined, 203
- Vertical piping, 317.B
- Vertical rise, 909.B
- Violations and penalties, 137
- Wall-hung bowls, 403.C
- Washing machine, protection, 415.M.1
  - residences, 415.M
  - separate trap, 415.M.2
- Waste acid, piping system, 703.F
- Waste outlet, laundry-tray, 415.G.1
  - lavatories, 413.A
  - sink, 413.B
- Waste pipe, indirect, 807
  - indirect, cleaning, 809.B
  - indirect, connections, 807.C
  - indirect, defined, 203
  - indirect, length, 809
  - indirect, material and size, 803
- Waste, clear water, 807.H
  - continuous, defined, 203
  - defined, 203
  - disposal units and single stack systems, 1811.D.5.f
  - grinder, 415.F
  - industrial, defined, 203
  - liquid, 807.H
  - pipe, defined, 203
  - receptor installation, 807.G.1
  - relief outlet, 511.F
  - stacks serving kitchen sinks, 729
- Water closet, 409, 415.N
  - public use of, 415.N.1
  - seat, 415.N.6
- Water distribution pipe, defined, 203
  - tubing and fittings, 603, 619
- Water distribution system, 1517
- Water distribution system-sizing, 611, 1805
- Water drain and connections, 415.J.1
- Water hammer arresters, air chambers, 607.I
  - shock absorbers, 607.I
  - hazard & noise, 607.I
- Waterless urinals, 409.A.2
- Water pumping and storage equipment, 615
- Water supply protection, 609
  - controls, 617
  - distribution, 613
  - mandatory, 609.A
  - quality, 605
  - system, 203, 621.H.4
  - test, 133, 319.C
  - where required, 609.C
- Water tanks, cleaning, painting and repairing, 615.C
  - drains, 615.G
  - overflow, 615.F
- Water heaters and hot water storage tank, Chapter 5

- Water, heating equipment, 509.A
  - main, defined, 203
  - outlet, defined, 203
  - pipes and sewer, 307.F
  - pressure valves or regulators, 607.J
  - pumping and storage equipment, 615
  - relief valves, 511.C
  - riser pipe, defined, 203
  - service pipe, 613
  - used for processing, 625.C
- Water-supply & distribution, Chapter 6
  - allowance for character of water, 601.C
  - color code, 607
  - disinfection of potable water supply piping, 601.B
  - hot-water distribution, 601.D
  - miscellaneous, 625
  - protection of potable water supply, 609
  - quality of water supply, 605
  - safety devices, 511
  - sizing of water distribution system, 611
  - water pumping & storage, 615
  - water supply control, 617
  - water supply distribution, 613, 619
  - water supply mandatory, 601.F
  - water-distribution pipe, tubing & fittings, 613, 619
- Welding or brazing, 315.D
- Wet vent, 203, 919
- Wiped joints, 313.C
- Workmanship, 301.E
  
- Yoke vent, defined, 203