



TIVOLI
XIV



SSANGYONG

STYLISH & VERSATILE

Tivoli XLV is stylish and practical, fun as well as versatile.

If you're looking for a small SUV but don't want to compromise on load capacity Tivoli XLV is the answer.

Whatever you need on your journey – bikes, golf clubs or luggage for five, Tivoli XLV has the answer. With a load capacity bigger than many in the class above, Tivoli XLV is the vehicle for those who want to downsize without compromise.







SPACIOUS & REFINED

Tivoli XLV redefines the standard for interior style and trim for a small crossover. A chunky D-cut steering wheel feels and looks good, the fascia is ergonomic, modern and purposeful.

Leather trim is standard and the front seats are heated – something not matched by Tivoli XLV's peers. This gives Tivoli XLV an interior usually found in vehicles at twice the price and makes travelling in a Tivoli XLV very special indeed.

Tivoli XLV doesn't scrimp on space either – there is plenty of room for driver and front seat passenger and three adults can travel comfortably in the rear thanks to the generously proportioned seats and nearly flat rear floor.



SMART INSTRUMENT CLUSTER

Tivoli XLV features a smart cluster that allows you to change its colour depending on your mood!

There's also a sophisticated trip computer on all Tivoli XLVs that shows tyre pressures, distance to empty, distance travelled and outside temperature.



WITHOUT LUGGAGE
BOARD 720L



WITH LUGGAGE
BOARD 574L

SPACE & STORAGE

Tivoli XLV is as practical as it is elegant - the boot boasts a maximum 720L cargo space and the second-row seats can be folded either 60:40 or fully flat for even greater carrying and flexibility.

The cargo bay comes with a luggage cover for security and a luggage board that hides underfloor storage, maximising luggage space.

The centre console is large enough to fit an iPad, while the glove box has a handy inner tray. All four doors have side pockets that can hold a 1.5L bottle and a variety of smaller items.



LUGGAGE BOARD
RAISED



LUGGAGE COVER



REAR SEATS
RECLINE 32.5°



AN INTERIOR FULL OF FEATURES

INFOTAINMENT

Tivoli XLV features a 7" touch screen with full European TomTom navigation. This highly specified unit controls radio, audio via USB or Bluetooth connection and your mobile phone via Bluetooth.



SMART STEERING



COMFORT

The steering wheel turns with less effort than when in Normal mode, good for use when parking, backing up or going forward at low speed.



NORMAL

The steering wheel effort is ideal for general driving.



SPORT

The steering wheel turns with greater effort than Normal mode, boosting steering responsiveness at high speed to ensure maximum operational control and precision.



AIR CONDITIONING

Tivoli XLV features a dual-zone air conditioning system which allows driver and passenger to set individual temperatures – and there's also a memory feature for next time you drive your Tivoli XLV!

SMART KEYLESS START

AUTOMATIC HEADLAMP &
RAIN SENSING WIPERS

REMOTE STEERING WHEEL
CONTROLS FOR RADIO,
PHONE AND CRUISE
CONTROL

REVERSING CAMERA

FRONT & REAR
PARKING SENSORS

1.6 LITRE DIESEL



- 1597cc
- 115PS @ 3,400 rpm
- 300Nm @ 1,500 rpm
- Combined mpg (4x2): 62.8 (manual), 47.9 (auto)
- Combined mpg (4x4): 57.6 (manual), 44.8 (auto)
- CO2 (4x2): 117 (manual), 154 (auto)
- CO2 (4x4): 127 (manual), 164 (auto)



TORQUE-ON- DEMAND 4X4



Tivoli XLV 4X4 features an advanced 4x4 system that operates in two modes depending on conditions and settings.

In auto mode and normal conditions, Tivoli XLV remains in two wheel drive to optimise fuel efficiency, When sensors detect a potential loss of grip, the system progressively engages the four wheel drive mode.

For very loose or slippery surfaces, the 4x4 system can be locked to allocate drive equally between front and rear wheels. This provides supreme grip and control for low-speed manoeuvres.

TRANSMISSIONS

Tivoli XLV has a choice of two modern and efficient 6 speed gearboxes – manual and automatic. Matched with our new 1.6 litre diesel they complement your driving style with smooth shifts and well-chosen gear ratios.

The automatic gearbox is sourced from Japanese supplier Aisin and is equipped with three alternative shift strategies – eco, power and winter to suit your driving needs.

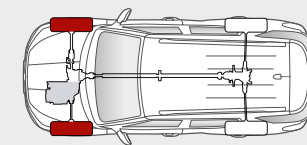

Mostly 2WD

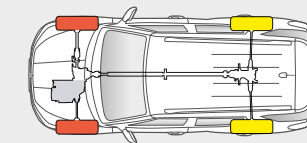

4WD for better stability

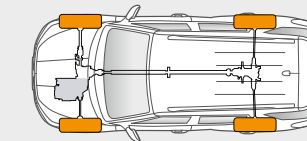

50:50 torque distribution(4WD lock)

SMART SAFETY

FORWARD COLLISION WARNING AND AUTONOMOUS EMERGENCY BRAKING

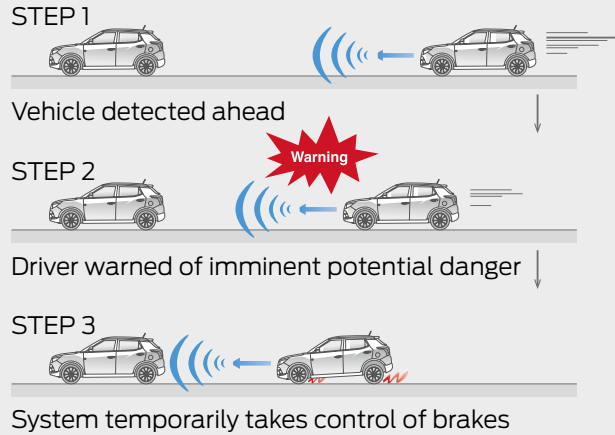

Evaluating data from the vehicle's on board camera, Forward Collision Warning (FCW) can detect a potential collision with a vehicle, pedestrian or obstacle. If a collision appears imminent FCW will warn the driver, and if there is insufficient response Autonomous Emergency Braking (AEB) will intervene with appropriate braking force to stop the vehicle or minimise damage.

LANE DEPARTURE WARNING AND LANE KEEPING ASSIST

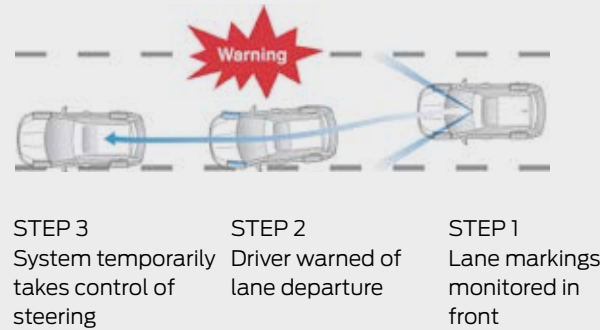

Lane Departure Warning (LDW) is designed to alert the driver that the vehicle is about to deviate from a traffic lane. Lane Keeping Assist (LKA) then helps the car stay toward the centre of the lane by applying a small amount of counter-steering force.



TRAFFIC SIGN RECOGNITION (TSR)
The system recognises speed limit signs and provides the driver with an on-screen warning. (EU region only)

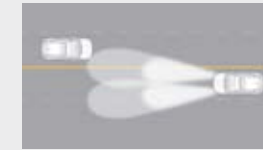

HIGH BEAM ASSIST (HBA)
Detects oncoming vehicles and lowers the high beams. The system

also tracks the taillights of vehicles in front and controls the high beams accordingly.



SEAT BELT PRE-TENSIONERS
In the event of a collision, the pre-tensioner immediately tightens the seatbelt over the chest and lap, ensuring the occupant is in the best possible restrained position if the airbags are deployed.

PASSIVE SAFETY



AIRBAGS

Tivoli XLV is equipped with 7 airbags for maximum passenger protection on impact – the most in its class. These include a driver's knee protection airbag – a feature normally found in prestige vehicles.

ISOFIX

Tivoli XLV is equipped with ISOFIX child seat mountings to the rear outer seats to allow firm and rigid attachment of child seats.

STRENGTH

The basis of a vehicle's safety is its monocoque structure – both how it's made and how it responds on impact. SsangYong's engineers have made extensive use of high strength steel to construct a rigid passenger cell.

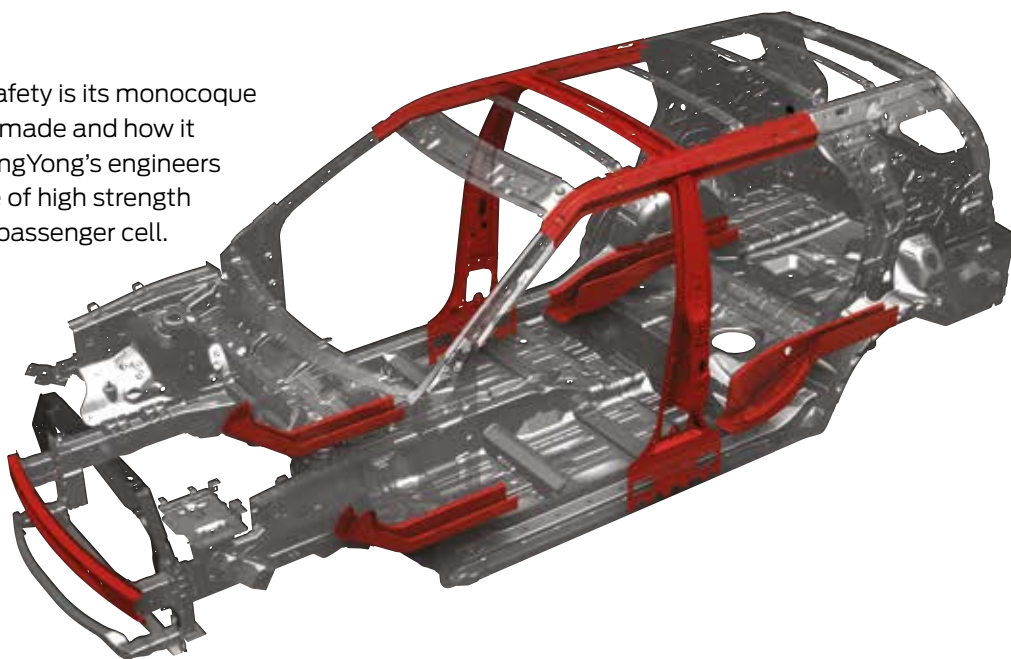

ACTIVE SAFETY

Tivoli XLV is equipped with the latest technology to assist the driver to avoid accidents.

T P M S

TYRE PRESSURE MONITORING SYSTEM

Tivoli XLV has tyre pressure monitoring built into its electronics. Monitored through the trip computer each tyre is continually checked for pressure with the driver immediately warned of unsafe pressures.

E B D — A B S

ELECTRONIC BRAKEFORCE DISTRIBUTION
ANTI-LOCK BRAKE SYSTEM

Brake force is distributed appropriately to the front and rear wheels according to the load of persons and/or cargo.

B A S

BRAKE ASSIST SYSTEM

This electronically controlled system automatically initiates full braking in an emergency to reduce the vehicle's braking distance and to help avoid an accident.

E S P

ELECTRONIC STABILITY PROGRAMME

The electronic stability programme monitors road conditions and vehicular status constantly, adjusting engine output and braking whenever the driver is about to lose control. The ESP integrates the anti-lock brake system, active rollover protection, anti-slip regulation and brake-force assist to improve the Tivoli XLV's intervention capabilities.

EQUIPMENT

✓ Standard ○ Optional

Comfort	
Height adjustable driver's seat	✓
Leather seats	✓
Front & rear seat warmers	✓
Chrome interior door handles	✓
Stainless steel front door kick plates	✓
Leather covered D-cut steering wheel & gear knob	✓
Tinted glass	✓
Privacy glass: rear door, quarter & tailgate	✓
Convenience	
Smart keyless start	✓
Stop & start system (manual only)	✓
Smart instrument cluster - six colour options	✓
Trip computer with outside temperature gauge	✓
Electric windows (front & rear)	✓
Automatic headlamps	✓
Rain sensing wipers	✓
Automatic dipping rear view mirror	✓
Smart steering	✓
Height and reach adjustable steering wheel	✓
Electronic cruise control	✓
Headlight levelling system	✓
Automatic power folding door mirrors	✓
Electrically operated & heated door mirrors	✓
60/40 split rear seats	✓
Luggage cover	✓
Removable luggage board	✓
Safety and security	
Dual front airbags with passenger off switch	✓
Side airbags	✓
Curtain airbags	✓
Driver's knee airbag	✓
Two stage front seatbelt pre-tensioners	✓
Electronic Stability Programme (ESP)	✓
Active Rollover Protection (ARP)	✓
ABS with Electronic Brakeforce Distribution (EBD)	✓
Forward Collision Warning (FCW)	✓
Autonomous Emergency Braking (AEB)	✓
Lane Departure Warning (LDW)	✓

Lane Keeping Assist (LKA)	✓
Traffic Sign Recognition (TSR)	✓
High Beam Assist (HBA)	✓
ISOFIX fittings to outer rear seats	✓
Automatic speed sensing door locks	✓
Alarm & immobiliser	✓
Exterior	
Piano black radiator grille	✓
Roof rails	✓
Projection headlamps	✓
Front & rear LED daytime running lights	✓
Rear spoiler with LED stop lamp	✓
Front fog lights	✓
18" diamond cut gun metal alloy wheels	✓
Tyre repair kit	✓
Mini spare	○
Tyre pressure monitoring system	✓
Front & rear parking sensors	✓
Climate and heating	
Dual-zone automatic air conditioning	✓
In car entertainment	
7" touch screen RDS radio with iPod & Bluetooth connectivity, TomTom navigation	✓
Rear view camera	✓
Steering wheel mounted audio controls	✓
Six speakers including two tweeters	✓
Roof mounted antenna	✓



18" DIAMOND
CUT GUN
METAL



18" DIAMOND
CUT BLACK

My TIVOLI

The My Tivoli programme allows a much wider choice of colours, trims and drivetrains than standard. My Tivoli vehicles are built to your order and allow for those special touches – a contrasting roof colour, further exterior colours and red leather seats are well worth a short wait for!

Ask your dealer for further information.



RED LEATHER PACK



	Standard colours					My Tivoli colours	
	Grand white	Silent Silver	Flaming Red	Dandy Blue	Space Black	Techno Grey	Jazz Brown
Paint finish	Solid	Metallic	Solid	Metallic	Metallic	Metallic	Metallic
Standard interior colour	Grey leather	Grey leather	Grey leather	Beige leather	Beige leather	Beige or grey leather	Beige or grey leather
Optional MyTivoli internal colour	Beige or red leather	Beige leather	Beige or red leather	Grey or red leather	Grey or red leather		
Contrast roof colour	Black	Black	Black	White	White	Black	Black
Wheel colour	Black alloy	Black alloy	Black alloy	Diamond cut alloy	Diamond cut alloy	Black alloy	Black alloy

TECHNICAL SPECIFICATION

	TIVOLI DIESEL MANUAL	TIVOLI DIESEL AUTOMATIC	TIVOLI DIESEL MANUAL 4X4	TIVOLI DIESEL AUTOMATIC 4X4
Engine and drivetrain				
Drivetrain	Front wheel drive		Torque on demand 4x4	
Engine capacity (cc)	1597			
Engine configuration	4 cylinders			
Emission standard	Euro VI			
Transmission	6 speed manual	6 speed automatic	6 speed manual	6 speed automatic
Fuel	Diesel			
Exhaust system	Catalyst			
Performance				
Top speed (mph)	106	108	106	108
0-62mph (sec)	12	12	12	12
Maximum power (PS/rpm)	115 / 3400-4000			
Maximum torque (Nm/rpm)	300 / 1500-2500			
Max unbraked trailer load (kg)	500			
Max braked trailer load (kg)	1500			
Towbar max load (kg)	80			
Economy & emissions				
Fuel consumption: combined mpg (l/100km)	62.8	47.9	57.6	44.8
Fuel consumption: urban mpg (l/100km)	55.4	37.7	52.3	35.8
Fuel consumption: extra urban mpg (l/100km)	67.3	57.6	61.4	53.3
CO2 emissions (g/km)	117	154	127	164
Dimensions				
Length (mm)	4440			
Width (mm)	1798			
Height inc roof rails (mm)	1635			
Wheelbase (mm)	2600			
Track: front/rear (mm)	1550			
Min turning radius (m)	5.3			
Overhang: front/rear (mm)	865/975			
Gross vehicle weight (kg)	1970		2060	
Kerb weight (kg)	1405	1425	1505	1535
Approach angle (deg)	20			
Departure angle (deg)	20.8			
Ramp angle (deg)	17.0			
Luggage space: seats upright (litres)	720L			
Fuel tank capacity (litres)	47L			
Running gear				
Steering	Electric power assisted rack and pinion			
Suspension (front/rear)	MacPherson strut/independent		MacPherson strut/multi-link	
Brakes (front/rear)	Vented disc/solid disc			
Insurance				
Group	15D			
Tyres	215 /45 R18			

DIMENSIONS



1798mm



865mm | 2600mm | 975mm
4440mm



1550mm

1635 mm

5 YEAR WARRANTY

All SsangYong vehicles are covered by a 5 year limitless mileage warranty. Our limitless mileage warranty really is best in class.



SSANGYONG
Est. Korea 1954
5 YEAR WARRANTY



For more information please call 0333 444 1954

The information in this brochure is not binding and is subject to alteration. SsangYong reserves the right to change specifications at any time without notice. The colour and finishes reproduced in this brochure are subject to the limitations of the printing process and may vary from the actual colour and paint finish. This brochure does not constitute an offer of sale of any particular vehicle or specification. Please confirm exact specifications, prices and colour availability with your SsangYong dealer or check the SsangYong website.