

**TM 10-7360-226-13&P**

---

# VERIFIED DRAFT

## TECHNICAL MANUAL

**OPERATOR'S, UNIT AND DIRECT SUPPORT  
OPERATION AND MAINTENANCE MANUAL  
(INCLUDING REPAIR PARTS & SPECIAL TOOLS LIST)  
FOR  
CONTAINERIZED KITCHEN  
NSN 7360-01-473-3408**

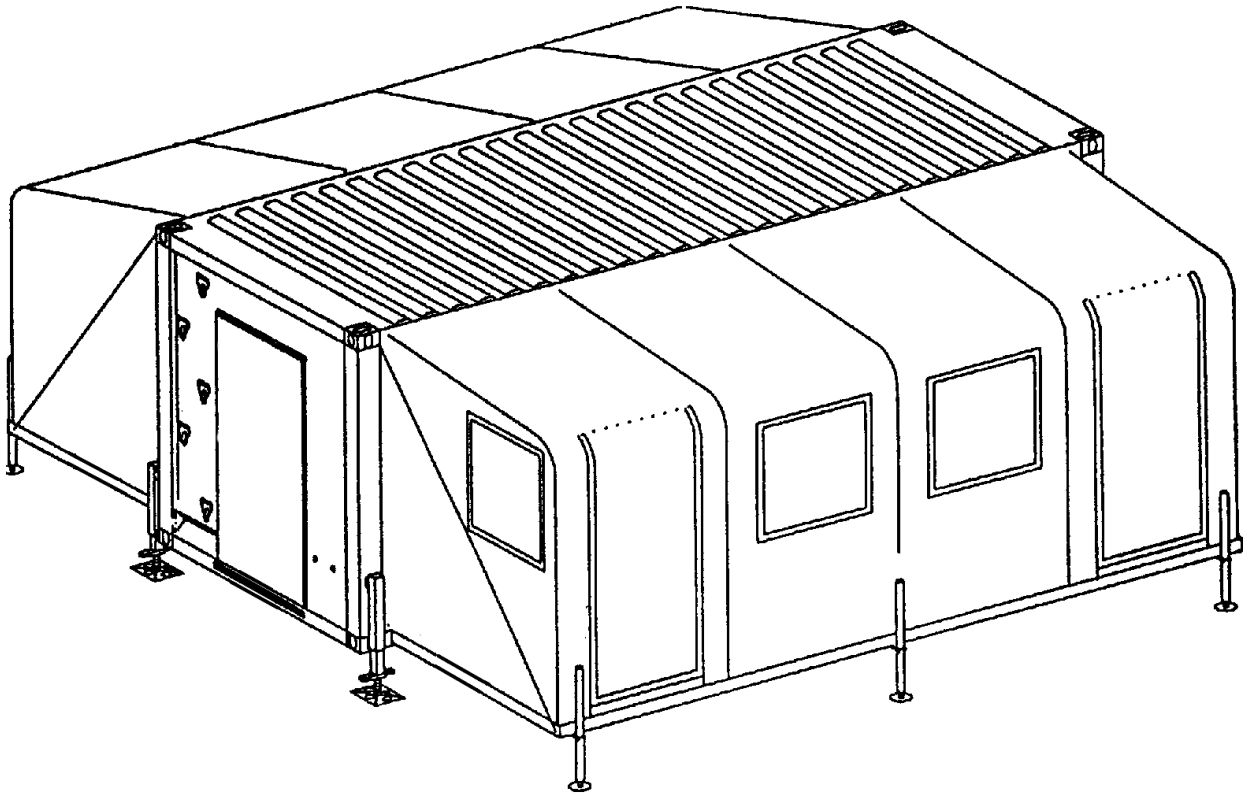

DISTRIBUTION STATEMENT A - Approved for public release; distribution is unlimited.

---

**HEADQUARTERS, DEPARTMENT OF THE ARMY**

## WARNING SUMMARY

This warning summary contains general safety warnings and hazardous materials warnings that must be understood and applied during operation and maintenance of this equipment. Failure to observe these precautions could result in serious injury or death to personnel.

### **WARNING**

#### **SHOCK HAZARD**

HIGH VOLTAGE is used in the operation of the CK. DEATH ON CONTACT may result if personnel fail to observe safety precautions.

DC voltage is present at the generator set electrical components even when it is shut down. Avoid grounding yourself when in contact with electrical components.

Lethal voltage is present when the MBU is connected to a power source. Serious injury or death by electrocution may occur if any energized component is touched.

Do not attempt to connect an energized cable to the Power Entrance Panel.

The CK MUST be properly grounded to ensure personnel safety and proper operation of the appliances and other electrical equipment. DO NOT energize the CK unless it is properly grounded.

Never work on electrical equipment unless there is at least one other person nearby who is familiar with the operation and hazards of the equipment. That person should also be competent in giving first aid. Ask maintenance personnel about extremely hazardous areas of the CK before doing any maintenance. For first aid, refer to FM 21-11.

Whenever possible, remove all power to the CK before performing any maintenance.

### **WARNING**

#### **NOISE HAZARD**

With its access door open, the noise level of the generator set when operating could cause hearing damage. Hearing protection MUST be worn when working near the generator set while it is running and its access door is open.

### **WARNING**

#### **TWO PERSON LIFT**

An MBU weighs approximately 58 lbs (26.3 kg) fully fueled. Two persons must carry the MBU when fully fueled, lifting with legs, not back, to prevent injury.

**WARNING**

**THREE PERSON LIFT**

The bags of arch frame components weigh approximately 130 lbs (59 kg) each, and the packed light storage box weighs approximately 100 lbs (45.4 kg). Three persons must carry these items, lifting with legs, not back, to prevent injury.

**WARNING**

**INHALATION HAZARD**

Generator exhaust contains deadly gases. DO NOT operate the generator in an enclosed area unless exhaust discharge is vented outside. Severe personal injury or death could occur due to carbon monoxide poisoning.

During operation, the MBUs produce carbon monoxide, a colorless, odorless, and tasteless gas. Prolonged inhalation of carbon monoxide will cause symptoms of drowsiness, headache, dizziness, and loss of muscular control. When using the MBUs, ensure that the operating space is well ventilated.

In the event of fluorescent lamp breakage, care must be taken in removing broken glass fragments and phosphorous dust that may be dispersed from the fixture. Inhaling phosphorous dust can cause personal injury.

**WARNING**

**FIRE HAZARD**

The fuel used in the generator is highly flammable. DO NOT smoke or use open flame when performing maintenance. Fire and explosion can occur, resulting in severe personal injury or death.

DO NOT attempt to connect a fuel line to an MBU in the vicinity of any open flame. Ensure that fuel connections are made properly to avoid fuel spillage. Prevent a possible fire hazard by having rags on hand to absorb any spillage.

**WARNING**

**HOT SURFACES**

Let the MBU cool down after operation before moving it or performing any maintenance. This will prevent burn injuries.

After generator operation, ensure that the generator exhaust pipe has cooled down before attempting to disassemble the elbow pipe.

Ensure that all CK components have completely cooled before initiating packout or performing maintenance.

**WARNING**

**HEAVY OBJECT**

Read and understand all instructions in this manual before installing or operating the jacks. Personal injury or property damage can occur if the jacks are improperly installed or operated.

NEVER allow anyone or any part of your body to be under any portion of the jacks or the CK container.

The corner and screw jacks are designed for use only with the CK. DO NOT use them to support or level any other container.

The orange safety straps MUST be in place before unlocking the cam-locks on the side wings.

When raising or lowering the wings, one member of the crew must act as a spotter to ensure that all personnel stay clear.

THIS PAGE INTENTIONALLY LEFT BLANK

**LIST OF EFFECTIVE PAGES/WORK PACKAGES**

Date of issue for the original manual is:

Original . . .

**TOTAL NUMBER OF PAGES FOR FRONT AND REAR MATTER IS 14 AND TOTAL  
NUMBER OF WORK PACKAGES IS 55 CONSISTING OF THE FOLLOWING:**

<b>Page/WP No.</b>	<b>*Revision No.</b>
a – c.....	0
d blank .....	0
A .....	0
B blank.....	0
i – iv .....	0
WP 0001 00 – 0055 00.....	0
Index-1 – Index-4 .....	0

\*Zero in this column indicates an original page or work package.

THIS PAGE INTENTIONALLY LEFT BLANK

HEADQUARTERS,  
DEPARTMENT OF THE ARMY  
WASHINGTON, DC

**TECHNICAL MANUAL**

**OPERATOR'S, UNIT AND DIRECT SUPPORT  
OPERATION AND MAINTENANCE MANUAL  
(INCLUDING REPAIR PARTS & SPECIAL TOOLS LIST)  
FOR  
CONTAINERIZED KITCHEN  
NSN 7360-01-473-3408**

**REPORTING ERRORS AND RECOMMENDING IMPROVEMENTS**

You can help improve this manual. If you find any mistakes or if you know of a way to improve the procedures, please let us know. Mail DA Form 2028 (Recommended Changes to Publications and Blank Forms), located in the back of this manual, directly to: Commander, U.S. Army Soldier and Biological Chemical Command, ATTN: AMSSB-RIM-E(N), Kansas Street, Natick, MA 01760-5052. You may also send your recommended changes via electronic mail directly to <amssb-rim-e@natick.army.mil>. A reply will be furnished to you. Instructions for sending an electronic 2028 may be found at the back of this manual immediately preceding the hard copy 2028.

DISTRIBUTION STATEMENT A - Approved for public release; distribution is unlimited.

**TABLE OF CONTENTS**

WP Sequence No.

**WARNING SUMMARY**

**HOW TO USE THIS MANUAL**

**CHAPTER 1 – INTRODUCTORY INFORMATION WITH THEORY OF OPERATION**

General Information.....	0001 00
Equipment Description and Data .....	0002 00
Theory of Operation .....	0003 00
Support Data for Repair Parts, Special Tools, TMDE, and Support Equipment .....	0004 00



**TABLE OF CONTENTS - Continued**

**CHAPTER 2 – OPERATOR INSTRUCTIONS**

Description of Operator Controls and Indicators .....0005 00  
Operation Under Usual Conditions .....0006 00  
Operation Under Unusual Conditions .....0007 00

**CHAPTER 3 – TROUBLESHOOTING PROCEDURES**

Introduction .....0008 00  
Malfunction/Symptom Index .....0009 00  
Troubleshooting Procedures – Electrical System .....0010 00  
Troubleshooting Procedures – Modern Burner Unit (MBU).....0011 00  
Troubleshooting Procedures – Environmental Control Unit (ECU).....0012 00  
Troubleshooting Procedures – Hand Sink Assembly .....0013 00  
Troubleshooting Procedures – Kitchen Appliances .....0014 00

**CHAPTER 4 – OPERATOR/UNIT MAINTENANCE PROCEDURES**

Service Upon Receipt.....0015 00  
Preventive Maintenance Checks and Services (PMCS) .....0016 00  
Shelter Unit Maintenance Procedures .....0017 00  
Mechanical Room Unit Maintenance Procedures .....0018 00  
Cook Center Unit Maintenance Procedures .....0019 00  
Dual Oven Assembly Unit Maintenance Procedures .....0020 00  
Mobile Warming Cabinet Unit Maintenance Procedures.....0021 00  
Refrigerator Unit Maintenance Procedures.....0022 00  
Tray Pack Heater Unit Maintenance Procedures.....0023 00  
Hand Sink Assembly Unit Maintenance Procedures.....0024 00  
Mobile Storage Cabinet Unit Maintenance Procedures .....0025 00  
Electrical System Unit Maintenance Procedures .....0026 00

**CHAPTER 5 – DIRECT SUPPORT MAINTENANCE PROCEDURES**

Cook Center.....0027 00  
Dual Oven Assembly.....0028 00  
Tray Pack Heater .....0029 00  
Shelter Assembly .....0030 00

TABLE OF CONTENTS – Continued

**CHAPTER 6 – SUPPORTING INFORMATION**

References.....0031 00

Maintenance Allocation Chart (MAC) .....0032 00

Introduction to Repair Parts & Special Tools List.....0033 00

Group 01 Shelter Repair Parts .....0034 00

Group 02 Mechanical Room Repair Parts .....0035 00

Group 03 Cook Center Repair Parts.....0036 00

Group 05 Dual Oven Assembly Repair Parts.....0037 00

Group 06 Mobile Warming Cabinet Repair Parts.....0038 00

Group 07 Refrigerator Repair Parts.....0039 00

Group 08 Tray Pack Heater Repair Parts .....0040 00

Group 09 Hand Sink Assembly Repair Parts.....0041 00

Group 10 Mobile Storage Cabinet Repair Parts.....0042 00

Group 11 Prep/Serving Table Repair Parts .....0043 00

Group 12 Electrical System Repair Parts .....0044 00

Group 13 Bulk Material Repair Parts .....0045 00

Special Tools List.....0046 00

National Stock Number Index.....0047 00

Part Number Index .....0048 00

Components of End Item (COEI) and Basic Issue Items (BII) Lists .....0049 00

Additional Authorization List (AAL) .....0050 00

Expendable and Durable Items List.....0051 00

Tool Identification List.....0052 00

Mandatory Replacement Parts.....0053 00

Wiring Diagrams.....0054 00

Appendix A – Trailer Operations.....0055 00

Index ..... Index-1

THIS PAGE INTENTIONALLY LEFT BLANK

## HOW TO USE THIS MANUAL

This manual contains general information, operating instructions, Preventive Maintenance Checks and Services (PMCS), and maintenance/repair instructions for the Containerized Kitchen (CK).

Front matter consists of front cover, warning summary, title block, table of contents, and how to use this manual pages. Chapter 1 provides introductory information on the CK and its associated equipment as well as theory of operation. Chapter 2 provides instructions for operating under usual and unusual conditions. Chapter 3 contains Operator troubleshooting procedures authorized at the unit level. Chapter 4 contains Preventive Maintenance Checks and Services (PMCS) and Operator/Crew maintenance instructions. Maintenance procedures authorized at the Direct Support level are found in Chapter 5. Chapter 6 contains the Maintenance Allocation Chart (MAC); it also includes the Repair Parts & Special Tools List (RPSTL) which identifies parts or tools unique to the operation and maintenance of the CK. Rear matter consists of the alphabetical index, DA Form 2028, authentication page, and back cover.

### Manual Organization and Page Numbering

This manual is divided into six major chapters that detail the topics mentioned above. Within each chapter are work packages covering a wide range of topics. Each work package is numbered sequentially starting at page 1, and has its own page numbering scheme that is independent of the page numbering used by other work packages. Each page of a work package has a page number of the form "XXXX YY-ZZ", where "XXXX YY" is the work package number (e.g. 0010 00 is work package 10) and "ZZ" represents the number of the page within that work package. A page number such as "0010 00-1/2 Blank" means that page 1 of that work package contains information but page 2 has been intentionally left blank.

### Finding Information

The Table of Contents permits the reader to quickly find information in the manual. The reader should start here first when looking for a specific topic. The Table of Contents lists the topics contained within each chapter and the work package sequence number where it can be found. The index, located at the back of the manual, lists topics in alphabetical order and identifies the work packages where the information is located.

THIS PAGE INTENTIONALLY LEFT BLANK

**TM 10-7360-226-13&P**

**CHAPTER 1**

**INTRODUCTORY INFORMATION  
WITH THEORY OF OPERATION**

THIS PAGE INTENTIONALLY LEFT BLANK

---

**CONTAINERIZED KITCHEN (CK)  
GENERAL INFORMATION**

---

0001 00

**SCOPE**

**Equipment Covered**

This technical manual contains instructions for the operation, preventive maintenance, Unit and Direct Support corrective maintenance for the Containerized Kitchen (CK) and its associated equipment.

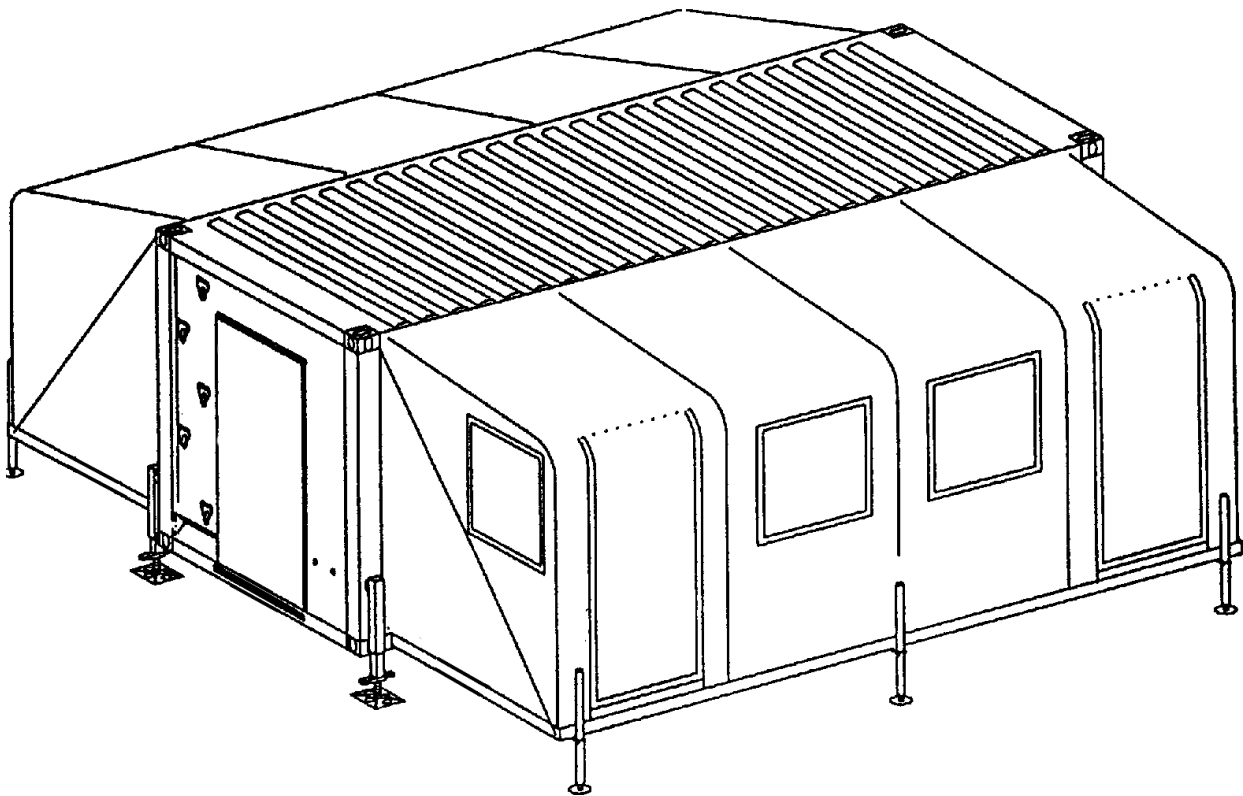

Figure 1. Containerized Kitchen.

**Type of Manual**

Operator's, Unit and Direct Support Operation and Maintenance Manual, including Repair Parts & Special Tools List.

**Equipment Name and Model Number**

Containerized Kitchen (CK), NSN 7360-01-473-3408, Part No. 47010000.



---

**CONTAINERIZED KITCHEN (CK)  
GENERAL INFORMATION**

0001 00

---

**Purpose of Equipment**

The CK is a mobile, rapidly deployable kitchen that is capable of preparing and serving up to 650 Army field menu meals (A-Ration, Heat and Serve Ration or any combination) up to three times per day. The CK enables cooks to prepare a meal (A-Ration) in less than three hours.

**MAINTENANCE FORMS, RECORDS AND REPORTS**

Department of the Army forms and procedures used for equipment maintenance will be those prescribed by DA PAM 738-750.

**EQUIPMENT IMPROVEMENT REPORT RECOMMENDATIONS (EIR)**

If your CK needs improvement, let us know. Send us an EIR. You, the user, are the only one who can tell us what you don't like about your equipment. Let us know why you don't like the design or performance. Put it on an SF 368, Product Quality Deficiency Report. Mail it to: Commander, U.S. Army Soldier and Biological Chemical Command; ATTN: AMSSB-RIM-E(N), Kansas Street, Natick, MA 01760-5052. We will send you a reply.

**CORROSION PREVENTION AND CONTROL (CPC)**

Corrosion prevention and control (CPC) of Army materiel is a continuing concern. It is important that any corrosion problem with the CK be reported so that the problem can be corrected and improvements can be made to prevent the problem in future items.

While corrosion is typically associated with rusting of metals, it can also include deterioration of other materials, such as rubber or plastic. Unusual cracking, softening, swelling or breaking of these materials may be a corrosion problem.

If a corrosion problem is identified, it can be reported using SF-368, Product Quality Deficiency Report. Use of key words such as "corrosion", "rust", "deterioration" or "cracking" will ensure that the information is identified as a CPC problem. The form should be submitted to the address specified in DA PAM 738-750, Functional Users Manual for the Army Maintenance Management System (TAMMS).

**DESTRUCTION OF ARMY MATERIEL TO PREVENT ENEMY USE**

For procedures to destroy the CK to prevent its use by the enemy, refer to TM 750-244-3.

**PREPARATION FOR STORAGE AND SHIPMENT**

The CK is stored and shipped only in its fully packed-out configuration. Refer to WP 0006 00 for packout procedures.

**WARRANTY INFORMATION**

SFA Inc., Frederick Manufacturing Division warrants the CK system to be free from defects in materials and workmanship for a period of one year from acceptance. The CK contains a number of items covered by the original equipment manufacturer's warranty.

**CONTAINERIZED KITCHEN (CK)  
GENERAL INFORMATION**

**0001 00**

These individual warranties vary in terms and conditions. SFA Inc., Frederick Manufacturing Division's warranty does not apply to these items since typically these individual equipment warranties provide coverage to the Government. Weatherhaven warrants the MECC to be free from defects in materials and workmanship for a period of one year from date of manufacture.

SFA Inc./Weatherhaven warrants all CK systems to be in compliance with the Performance Specification, Statement of Work, and design requirements as determined by the Government's first article testing of the first two CK systems.

**NOMENCLATURE CROSS-REFERENCE LIST**

<u>Common Name</u>	<u>Official Nomenclature</u>
CK	Containerized Kitchen

**LIST OF ABBREVIATIONS/ACRONYMS**

The following abbreviations/acronyms are used in this manual

<b>TERM</b>	<b>DEFINITION</b>	<b>TERM</b>	<b>DEFINITION</b>
AAL	Additional Authorization List	ECU	Environmental Control Unit
AC	Alternating Current	EIR	Equipment Improvement Recommendation
AMC	Air Mobility Command	EMP	Electromagnetic Pulse
amp	ampere	FDA	Food and Drug Administration
AVIM	Aviation Intermediate Maintenance	FGC	Functional Group Code
AVUM	Aviation Unit Maintenance	ft	foot, feet
BII	Basic Issue Items	gal	gallon (U.S.)
BOI	Basis of Issue	GFI	ground fault interrupter
BTU	British thermal unit	gpm	gallons per minute
CAGEC	Commercial and Government Entity Code	GS	General Support
CB	Circuit breaker	HCI	Hardness Critical Item
cfm	Cubic feet per minute	Hz	Hertz (cycles per second)
CK	Containerized Kitchen	in	inch, inches
COEI	Components of End Item	ISO	International Organization for Standardization
CPC	Corrosion Prevention and Control	kg	kilogram
CSC	Convention for Safe Containers	kW	kilowatt
CTA	Common Table of Allowances	lb	pound
°C	Degrees Celsius	LO	Lubrication Order
DA PAM	Department of the Army Pamphlet	MAC	Maintenance Allocation Chart
DC	Direct Current	MBU	Modern Burner Unit
DS	Direct Support	MCP	Main Control Panel
°F	Degrees Fahrenheit	MECC	Mobile Expandable Container Configuration

**CONTAINERIZED KITCHEN (CK)  
GENERAL INFORMATION**

**0001 00**

MTOE	Modified Table of Organization and Equipment	RPSTL	Repair Parts & Special Tools List
NBC	Nuclear, Biological, and Chemical	SF	Standard Form
NHA	Next Higher Assembly	SMR	Source, Maintenance and Recoverability
NSF	National Sanitation Foundation	SRA	Specialized Repair Activity
NSN	National Stock Number	SS	Stainless Steel
OD	outside diameter	TMDE	Test Measurement and Diagnostic Equipment
PDP	Power Distribution Panel	TQG	Tactical Quiet Generator
PEP	Power Entrance Panel	TOE	Table of Organization and Equipment
PMCS	Preventive Maintenance Checks and Services	UL	Underwriters Laboratories
P/N	Part Number	U/M	Unit of Measure
psig	pounds per square inch gauge	UOC	Usable On Code
PVC	polyvinyl chloride	UUT	Unit Under Test
qty	quantity	UV	Ultraviolet
		V	Volt, volts
		VAC	Volts Alternating Current
		VDC	Volts Direct Current
		WP	Work Package

**NUCLEAR HARDNESS**

The CK is not nuclear hardened.

---

**CONTAINERIZED KITCHEN (CK)  
EQUIPMENT DESCRIPTION AND DATA**

---

0002 00

**EQUIPMENT CHARACTERISTICS, CAPABILITIES AND FEATURES**

The Containerized Kitchen is a mobile, self-contained field kitchen configured in an 8-ft by 8-ft by 20-ft International Organization for Standardization (ISO) container. The container meets all ISO and U.S. Coast Guard requirements for safe containers, including nine-high stacking. The dry weight of the CK system, excluding the trailer, is approximately 14,000 lb (6356 kg). It is transportable in C-130 and larger Air Mobility Command (AMC) aircraft. When mounted on its trailer as shown in Figure 1, it is capable of being externally transported (sling loaded) by a CH-47D rotary wing aircraft. The CK can withstand the shocks and vibrations encountered in ground transportation by either rail or truck without damage, and when mounted on its trailer can be transported over primary roads, secondary roads, and cross-country terrain.

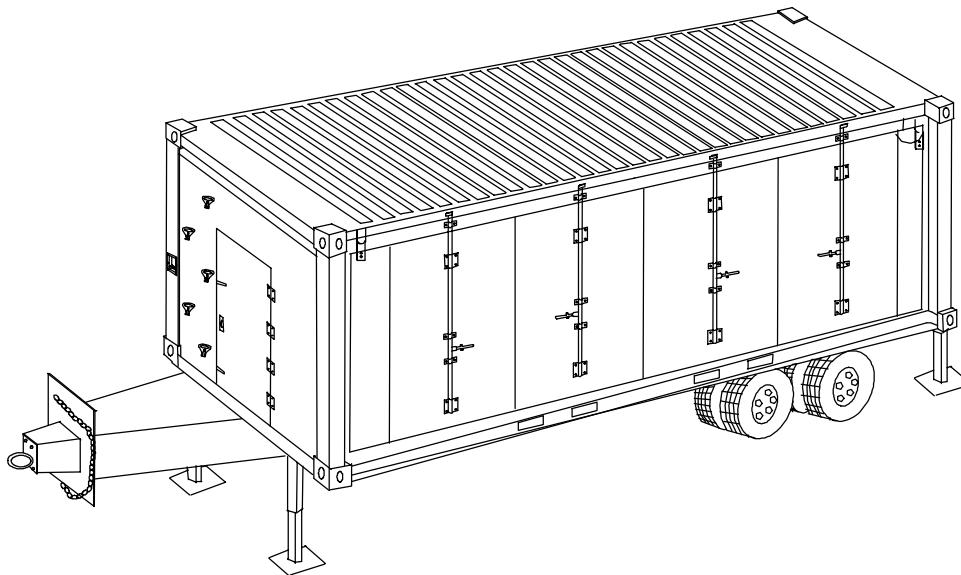

Figure 1. CK Mounted on Trailer.

When configured for food preparation, the CK provides approximately 360 square feet of food preparation and serving areas protected from natural elements of the environment. All food preparation equipment, the electrical supply, the environmental control system, and all related controls are mounted inside the CK.

The CK is capable of preparing and serving up to 650 Army field menu meals (A-Ration, Heat and Serve Ration or any combination) up to three times per day. An A-Ration meal can be prepared in less than three hours.

The CK requires less than 45 minutes to set up or tear down by a crew of four personnel and a supervisor. It has the capability to prepare and serve meals while mounted on a towed trailer or while dismantled.

---

**CONTAINERIZED KITCHEN (CK)  
EQUIPMENT DESCRIPTION AND DATA**

---

**0002 00**

Integrated equipment includes a griddle, steam table, cook pot cradles, tray pack heater, and two ovens, all heated by Modern Burner Units (MBUs). A permanent fuel distribution system provides fuel to the MBUs, eliminating the need for the cooks to handle fuel within the kitchen. Two refrigerators with a combined volume of 58.4 cubic feet are included. A hand sink for hot and cold potable water, an electric mobile warming cabinet, two mobile storage cabinets and four food preparation/serving tables are also provided. The kitchen also includes pots, pans, baking sheets, roasting pans, insulated food and beverage serving containers, and a full complement of cooking and serving utensils. Sufficient cabinet and drawer space is provided to house all of the included equipment. A rifle rack, mounted on the wall beside the personnel access door, provides storage for the crew's weapons.

The CK contains a 10kW Tactical Quiet Generator (TQG), and provisions for receiving power from an external source. It includes both normal (white) and red (blackout) lighting. A full array of controls and indicators are provided, including an emergency shutoff switch to rapidly shut off all power to the kitchen in the event of an emergency.

The CK can operate under all external ambient conditions anticipated for a mobile military system, including temperatures ranging from -25°F to 120°F. It includes an integrated environmental control system designed to maintain a reasonably comfortable operating environment for the cooks.

**CONTAINERIZED KITCHEN (CK)  
EQUIPMENT DESCRIPTION AND DATA**

0002 00

**LOCATION AND DESCRIPTION OF MAJOR COMPONENTS**

The CK provides approximately 390 square feet of enclosed floor space. About 30 square feet is used as a mechanical room to house the generator, air conditioners, and ventilation fans. The remaining space encompasses the food preparation and serving areas. Figure 2 and Figure 3 illustrate the kitchen layout, which allows five cooks to work efficiently, comfortably, and conveniently.

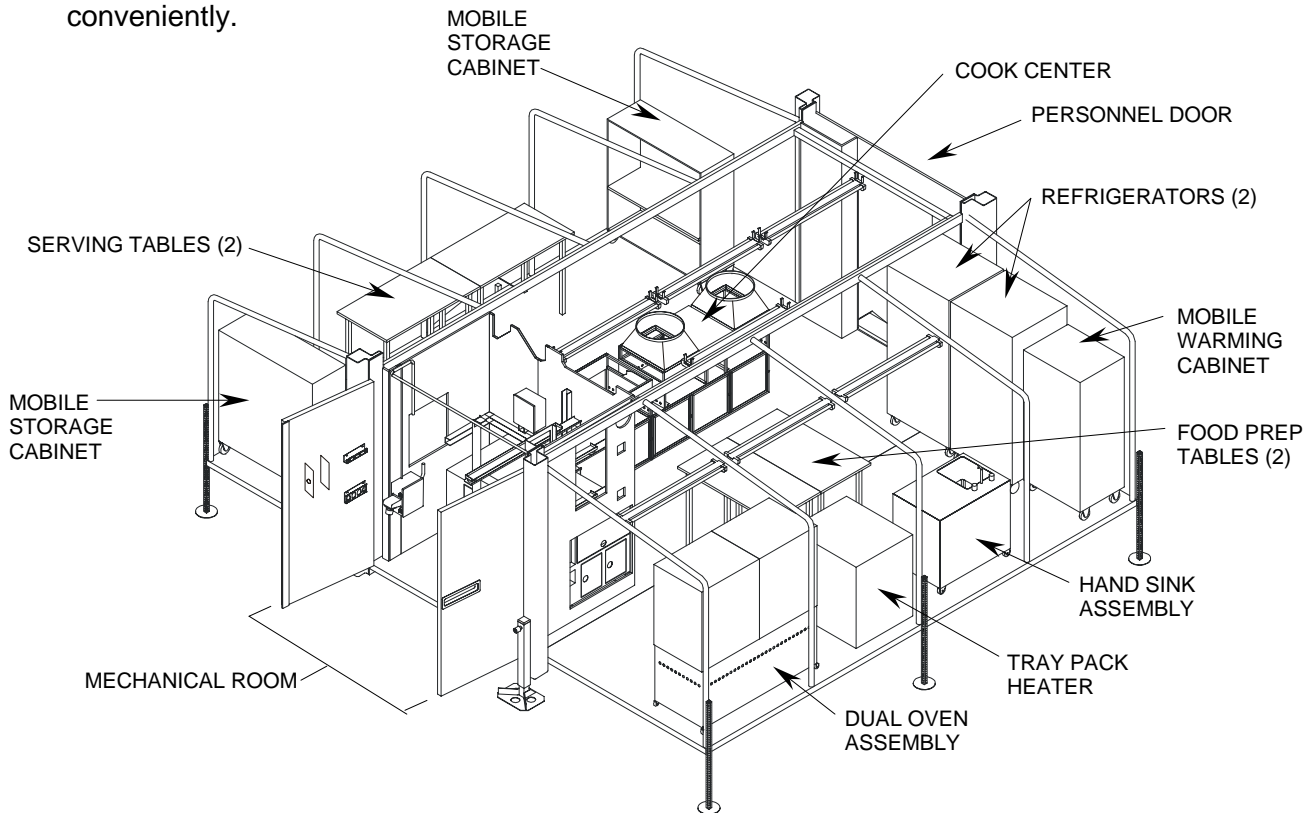

Figure 2. Containerized Kitchen, Food Preparation Side View.

**CONTAINERIZED KITCHEN (CK)  
EQUIPMENT DESCRIPTION AND DATA**

**0002 00**

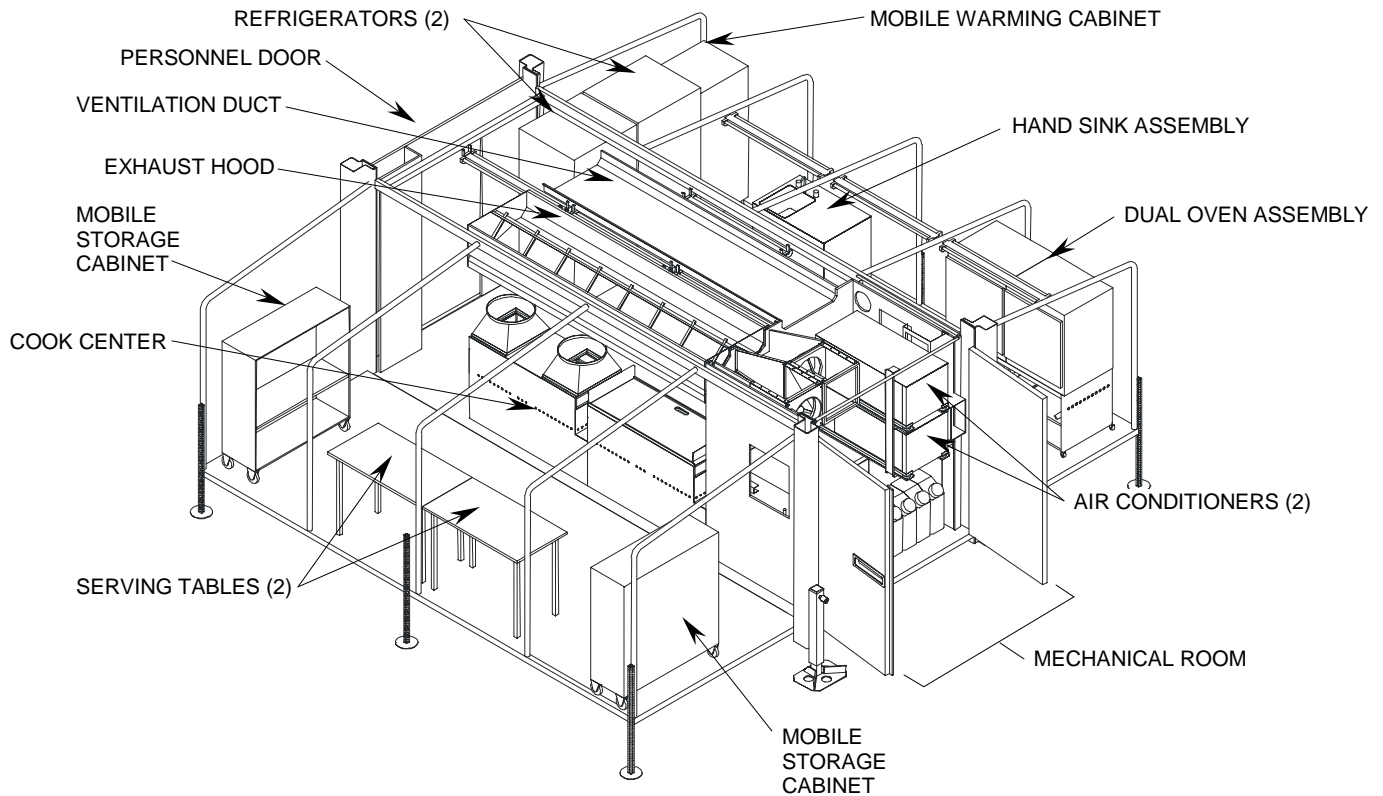

Figure 3. Containerized Kitchen, Serving Side View.

Figure 4 shows the cook-equipment interface during meal preparation, and illustrates the area of operation for the five cooks. Each cook has access to the central island, consisting of two food preparation tables. Cook #1 is a support person having access to the refrigerators, sink and mobile warming cabinet. Cook #2 has access to the two ovens and the tray pack heater. Cook # 3 has access to the ovens, generator controls, spice rack, and the electrical controls (not illustrated) to the right of the spice rack. Cook #4 and Cook #5 have access to the griddle and steam table/cooking racks, respectively.

**CONTAINERIZED KITCHEN (CK)  
EQUIPMENT DESCRIPTION AND DATA**

0002 00

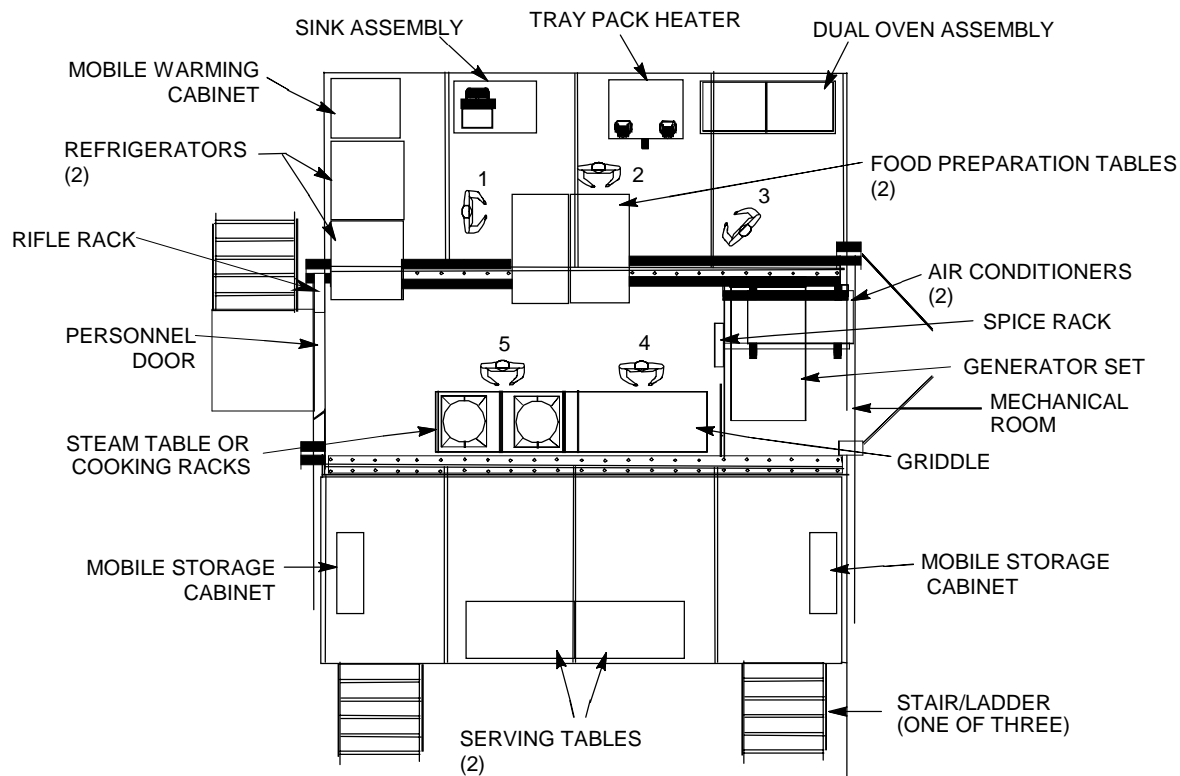

Figure 4. Cook/Equipment Interface.

The overall layout of the CK is oriented around a central cook center located in the shelter core. The cook center houses four MBUs which can heat any two of the following: the griddle, the steam table, or two cook pots, any of which can be set up on either the left or right half of the cook center. The cook center also serves as the dividing line between the food preparation and the serving areas. An aisleway allows personnel to freely move between the two areas without exiting the shelter. Integral to the cook center are provisions for both electrical and fuel connections for five MBUs. Four of these connections are fixed within the cook center to accommodate the cook pots, the griddle, and the steam table. A fifth connection at the aisleway supplies the tray pack heater or the cook pot cradle assembly. The cook center also has a tray slide on the serving side for soldiers to use. A ventilation exhaust system is mounted above the heat and steam-producing appliances on the cook center, extending its full length.

In the center of the work space, two tables are set up as a food preparation island which is accessible from all areas of the kitchen and convenient for all five cooks. The refrigerators, warming cabinet, sink, tray pack heater, and ovens are located along the perimeter of the expandable sidewalls. The tray pack heater and the ovens are located at the mechanical room end, with electrical and fuel connections provided. Most of the A-Rations loaded into the CK require refrigeration, so the refrigerators are located next to the personnel access door. In the serving area, two field tables and two storage cabinets are provided. Two access doors on this side of the expandable shelter provide access to the serving area. Personnel enter one door and exit the other. The field tables can be used as an extra length of food preparation surface or for laying out condiments while food is being served.



## CONTAINERIZED KITCHEN (CK) EQUIPMENT DESCRIPTION AND DATA

0002 00

The mechanical room, Figure 5, houses the CK's utility components. These include the generator, air conditioners, ECU controller, MBU converter, electrical distribution panels and ventilation fans. The generator is mounted on the floor, with the air conditioners and ventilation fans mounted above. An extension pipe routes the engine exhaust to the outside. A second extension directs the engine radiator cooling air to the outside through a cloth duct. Cloth ducts also route the ventilation system exhaust fan discharge and the air conditioner condenser cooling air to the outside.

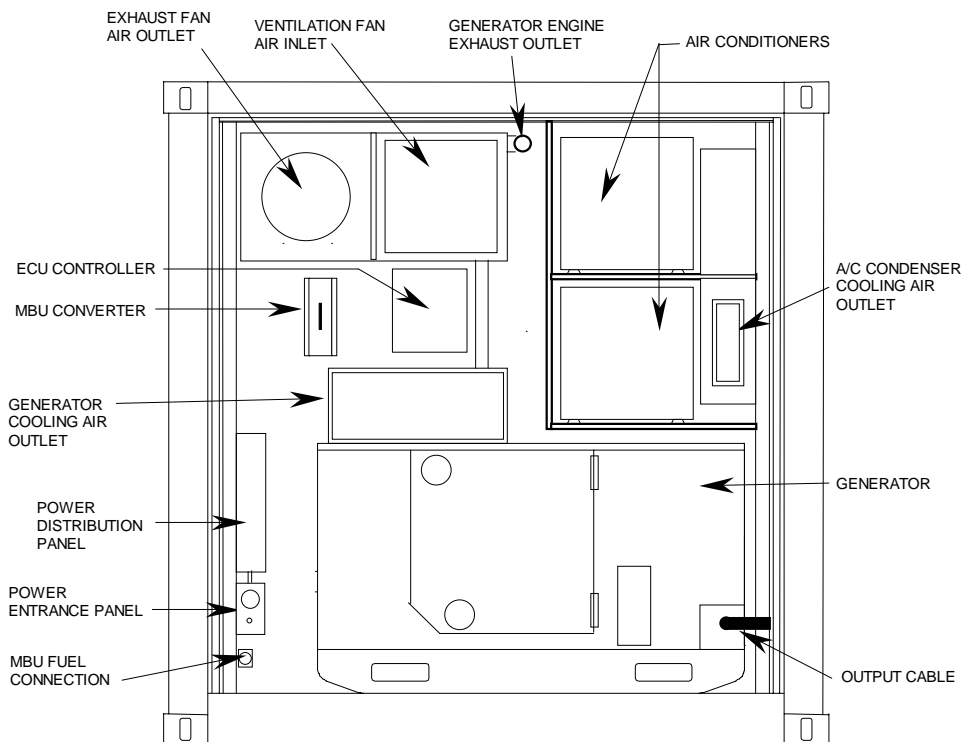

NOTE: AIR OUTLET CANVAS DUCTS OMITTED FOR CLARITY

Figure 5. Mechanical Room.

Exterior doors provide access to the mechanical room for installation, removal, and maintenance of the utility systems. These doors seal the mechanical room from external environmental conditions such as rain, sand, dust and salt spray during transport. They must remain open while in the operational mode to provide for generator and ventilation system exhaust. A foldout awning, stored in the mechanical room, can be deployed across the top of the open doors to provide protection from rain, sand, and dust.

Controls for the ECU, cook center ventilation, and MBU power are located on the food preparation side of the mechanical room wall, near the cook center. An access door with a transparent window, located in the bottom portion of the wall, provides access to generator's control and malfunction indicator panels.

**CONTAINERIZED KITCHEN (CK)  
EQUIPMENT DESCRIPTION AND DATA**

0002 00

The Container Safety Certification Plate and System Identification Plate are located to the left of the personnel access door at the end of the shelter core. These are illustrated in Figure 6 and Figure 7, respectively.

<b>CSC SAFETY APPROVAL</b>					
MANUFACTURED BY:			MANUF. SERIAL NUMBER:	<input type="text"/>	
	<b>Weatherhaven™</b> 5700 Marine Way, Burnaby, B.C. Canada Phone (604) 451-8900 Fax (604) 451-8999		DATE MANUFACTURED:	<input type="text"/>	
			US PATENT NO. 5,761,854		
TESTING CONDUCTED AT:	TRI-METAL FABRICATORS	I.D. NUMBER:	<input type="text"/>		
MAXIMUM GROSS WEIGHT:	<input type="text" value="10,886"/> KG	<input type="text" value="24,000"/> LB			
MAXIMUM PAYLOAD:	<input type="text" value="6,800"/> KG	<input type="text" value="15,000"/> LB			
ALLOWABLE STACKING WEIGHT FOR 1.8 g	<input type="text" value="86,471"/> KG	<input type="text" value="190,637"/> LB			
RACKING TEST LOAD VALUE	<input type="text" value="4,672"/> KG	<input type="text" value="10,300"/> LB			
END WALL STRENGTH	<input type="text" value="2,722"/> KG				
SIDE WALL STRENGTH	<input type="text" value="4,082"/> KG				
NEXT EXAMINATION DUE (MONTH & YEAR)	<input type="text"/>	<input type="text"/>	<input type="text"/>	<input type="text"/>	<input type="text"/>
ELECTRICAL SPECIFICATIONS	<input type="text"/>	<input type="text"/>	<input type="text"/>	<input type="text"/>	<input type="text"/>
	VOLTAGE	AMPERAGE	PHASE	WIRE	FREQUENCY

Figure 6. Container Safety Certification Plate.

NOMENCLATURE:	<input type="text" value="CONTAINERIZED KITCHEN"/>
PART NUMBER:	<input type="text" value="47010000"/>
SERIAL NUMBER:	<input type="text"/>
CONTRACT NO:	<input type="text" value="DAAD15-99-D-0001"/>
CAGE CODE:	<input type="text" value="0U5N7"/>
NSN:	<input type="text" value="7360-01-473-3408"/>
DATE:	<input type="text"/>
GROSS WEIGHT:	<input type="text"/>



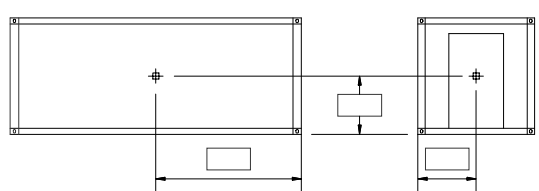

**FREDERICK MFG. DIV.**

Figure 7. CK Identification Plate.

---

**CONTAINERIZED KITCHEN (CK)  
EQUIPMENT DESCRIPTION AND DATA**

---

0002 00

In the transport mode, the CK provides the necessary space, storage area, and tie-downs required to stow all items of the system inside the container. The equipment packout is configured to distribute the weight throughout the container as evenly as possible.

**Shelter**

The CK shelter, Figure 8, consists of a fixed, rigid core with two hinged, expandable wings. The all-steel frame structure of the shelter core is designed to ISO specifications and meets the dimensional requirements of ISO Standards 668 and 1161, as well as U.S. Coast Guard requirements for safe containers in accordance with the international Convention for Safe Containers (CSC). When configured to its compact ISO shipping format, the shelter is easily transported by truck, rail, sea, or air. The shelter has been tested and certified to nine-high stacking and thus permits the stacking of eight fully loaded ISO containers on top of one. The shelter floor area expands to provide about 360 square feet of sheltered floor space.

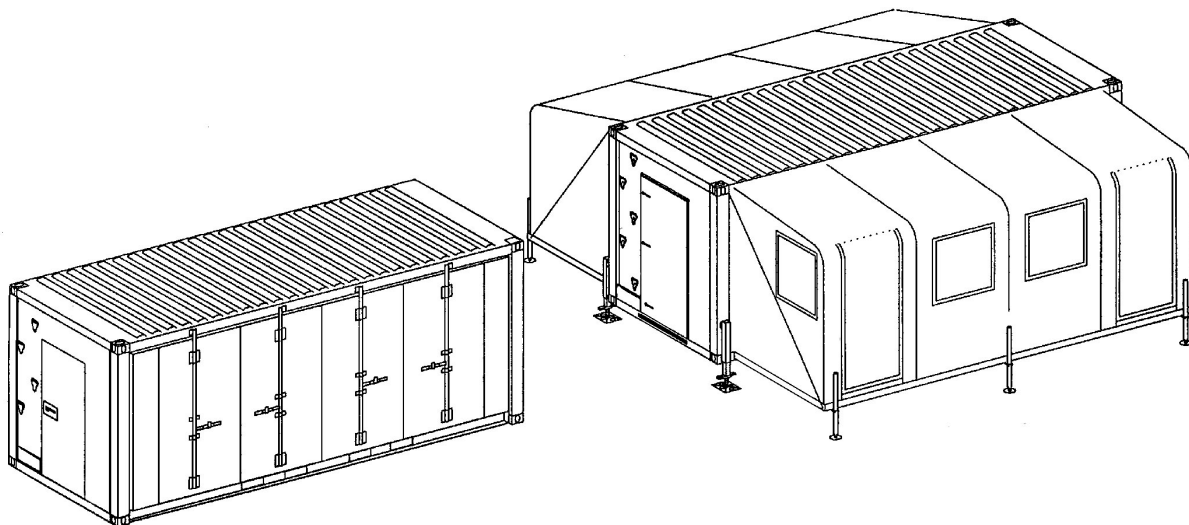

Figure 8. The CK Shelter.

The expandable side walls are hinged at the container base, sealed with rubber weatherproof seals, and incorporate four anti-racking door locks which are used in the transport mode. The side walls are lowered by mechanical winches to form the floors of the wings when the kitchen is deployed.

Each side wall of the shelter incorporates an insulated fabric section that provides the roof, side, and end walls of the expandable wing. The fabric section is permanently attached and sealed to the container framework with a watertight butyl rubber tape to prevent leakage. The fabric section consists of three layers: an external durable, UV-resistant and weatherproof vinyl coated polyester soft wall cover, an opaque insulation layer, and an inner liner. The expandable fabric cover is manufactured from technologically advanced vinyl that exhibits high tear strength, fire retardance, and resistance to mildew and ultraviolet radiation. The cover material is designed for use in ambient conditions from -67°F to +149°F.

The fabric cover is supported by steel arches, which use a spreader mechanism to put tension on the cover. The arches are disassembled and stored in vinyl bags for packout.

**CONTAINERIZED KITCHEN (CK)  
EQUIPMENT DESCRIPTION AND DATA**

0002 00

**Cook Center Assembly**

The cook center assembly, Figure 9, houses four MBUs over which any two of the following can be placed: the griddle, the steam table and adapter top, or two cook pot cradle adapters and cook pot cradles. Any of these items can be set up on either half of the cook center. The cook center includes a base foundation with storage areas, and mounts the serving line tray slide.

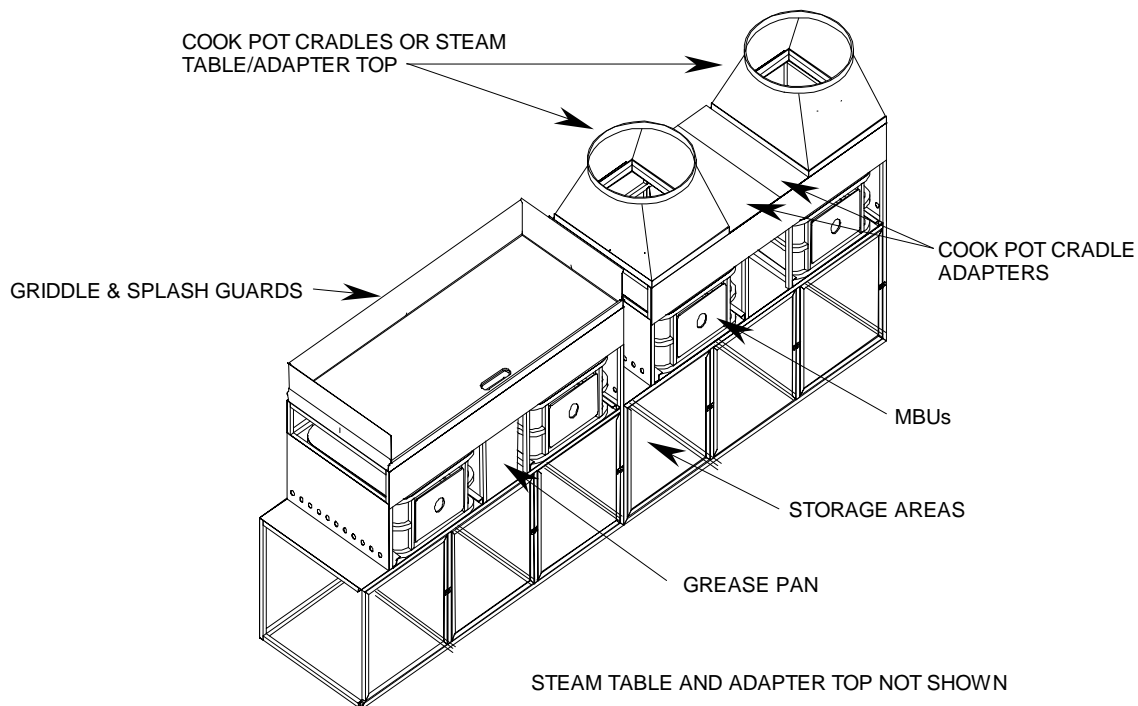

Figure 9. Cook Center Assembly.

**Cook Pot Assembly**

The cook pot assembly, Figure 10, allows the use of a cook pot while the cook center is configured with the griddle and steam table. The assembly consists of a base rack; a burner rack; and one of the cook pot cradle adapters, cook pot cradles, and MBUs. The assembly can be placed at the end of the cook center or to the left of the dual oven assembly, where there are fuel and electrical connections for the MBU.

**CONTAINERIZED KITCHEN (CK)  
EQUIPMENT DESCRIPTION AND DATA**

**0002 00**

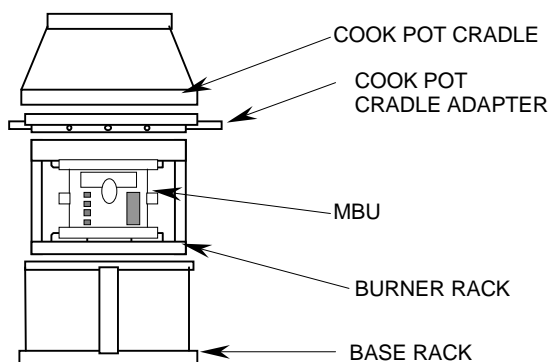

Figure 10. Cook Pot Assembly

**Dual Oven Assembly**

The dual oven assembly, Figure 11, consists of two MBU-fired ovens mounted on a mobile base cabinet. Integral casters allow it to be easily moved between its operational and transport locations. The assembly includes an integral exhaust gas oven fan and chimney pipe that penetrates the fabric wall when positioned for operation. Positioning rails, permanently attached to the floor at the assembly's operational location, position it with the correct clearance to prevent damage to the walls from overheating.

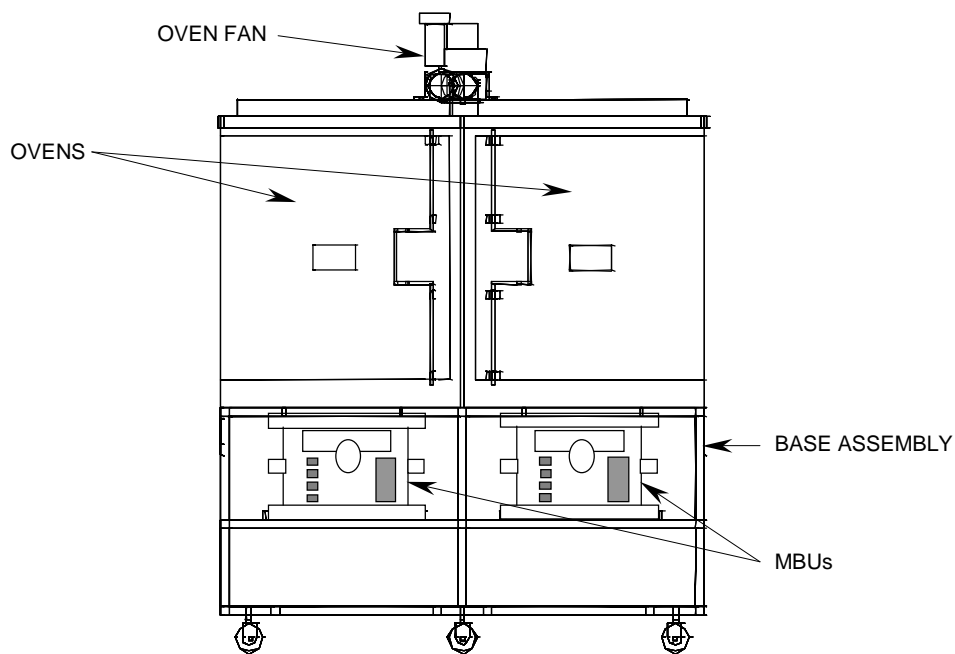

Figure 11. Dual Oven Assembly.

---

**CONTAINERIZED KITCHEN (CK)  
EQUIPMENT DESCRIPTION AND DATA**

---

0002 00

**Refrigerators**

Two refrigerators provide approximately 58 cubic feet of refrigerated storage. The refrigerators use R-134a refrigerant, which is commercially available, environmentally safe, and non-ozone-depleting.

**Mobile Warming Cabinet**

The mobile warming cabinet holds up to 10 full-size, 6-inch-deep steam table pans. Removable/adjustable slides are provided in the cabinet. Each slide can hold two standard pans. The cabinet has double doors with latches to hold them closed during transport and is equipped with heavy-duty swivel casters, two with brakes. A thermometer on the control panel displays the cabinet's internal temperature.

**Hand Sink Assembly**

The hand sink assembly, Figure 12, is a modular, self-contained hand washing station consisting of a sink, faucet, water heater, pump, waste water drain, liquid soap dispenser, and paper towel dispenser integrated into a mobile aluminum cabinet. The cabinet has four swivel casters, two with brakes, for easy movement between the transport and operational mode locations.

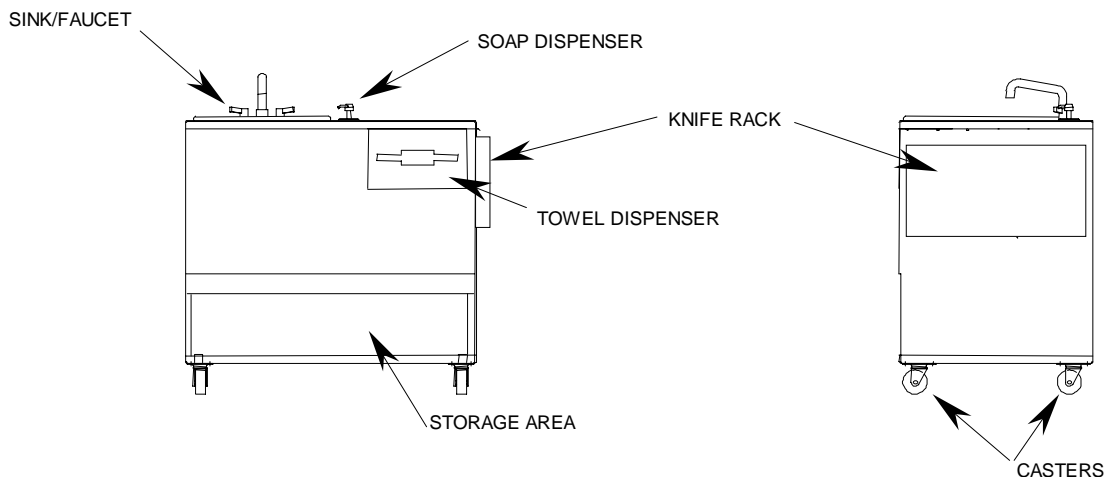

Figure 12. Hand Sink Assembly.

Potable water from any non-pressurized external source is routed to a hose connection on the back of the cabinet. An on-demand, diaphragm pump draws water to the sink. The pump is designed for drinking water use, and is self-priming. It includes a check valve to prevent reverse flow and an integral pressure switch to detect water pressure and provide the on-demand feature. The maximum flow rate is approximately 3 gpm.

Drain cocks at the low points in the sink's plumbing allow all of the piping and the water heater to be drained for packout. In the transport mode, the water supply hose, external drain hose, and interior drain hose are packed in storage spaces at the bottom of the sink cabinet.

**CONTAINERIZED KITCHEN (CK)  
EQUIPMENT DESCRIPTION AND DATA**

---

0002 00

**Tray Pack Heater**

The CK includes a modified tray pack heater which is positioned to the left of the dual oven assembly. The heater connects to the fuel and power lines on the back of the oven base.

**Generator**

A MEP-803A Tactical Quiet Generator (TQG) is located in the mechanical room, separate from the cooking and serving areas. The generator's controls and indicators are accessible through a door in the oven side of the mechanical room wall. Access to the generator for routine maintenance is through a second door in the mechanical room wall, next to the cook center, and through the exterior doors of the mechanical room. Refer to TM 9-6115-642-10 for more information about the generator.

**Power Entrance Panel and External Power**

The CK can be powered by an external source via the Power Entrance Panel (PEP), located next to the generator. This panel is a "waterfall" type that allows easy strain relief for the power cable and connector. External power can be provided from a 120/208 volt, 50/60 Hz, 60 amp, 5-wire, 3-phase source. The power is connected through a box-mounted receptacle with flange ring. A grounding terminal below the receptacle provides a connection for earth ground.

**Lighting**

Nine dual-tube, fluorescent fixtures provide the CK's interior lighting. Six provide white light for normal operations and three have red filters to provide blackout lighting. The normal and blackout lights are located as shown in Figure 13. Four of the fixtures are permanently mounted in the core of the kitchen. The rest are removable and are divided between the two wing sections. The removable fixtures attach to the wing arch supports and are removed for packout.

The white light fixture nearest the personnel access door contains a rechargeable nickel-cadmium battery and circuitry to provide emergency lighting. If power to the CK is lost, this fixture will operate for at least 90 minutes, providing light for personnel to evacuate the kitchen. It can also be used to provide lighting during kitchen setup, until electrical power is connected. The battery automatically recharges when power is connected to the kitchen. A test switch on the fixture allows for testing operation of the emergency light feature.

---

**CONTAINERIZED KITCHEN (CK)  
EQUIPMENT DESCRIPTION AND DATA**

---

0002 00

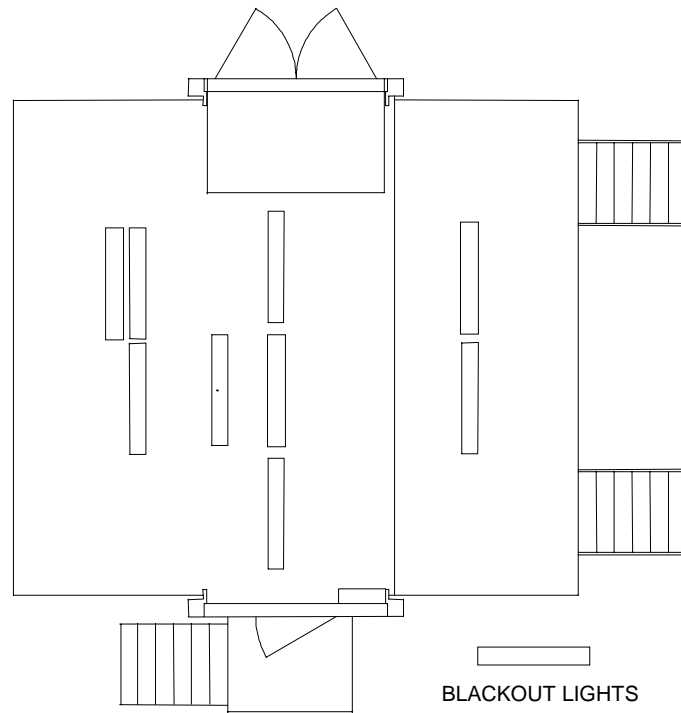

Figure 13. Lighting Fixture Layout.

The lighting controls, described in detail in WP 0003 00, include switches for operating the lights and for selecting the lighting mode (normal or blackout).

**Exhaust System**

The principal component of the CK's exhaust system is the exhaust hood mounted over the length of the cook center, Figure 14. Heat, water vapor, and fumes rising from the cook center equipment are exhausted by the hood. The hood also includes a makeup air supply to prevent conditioned air in the kitchen from being drawn out by the hood, and an air curtain that contains the heat from the cook center until it is drawn out by the exhaust fan.



## CONTAINERIZED KITCHEN (CK) EQUIPMENT DESCRIPTION AND DATA

0002 00

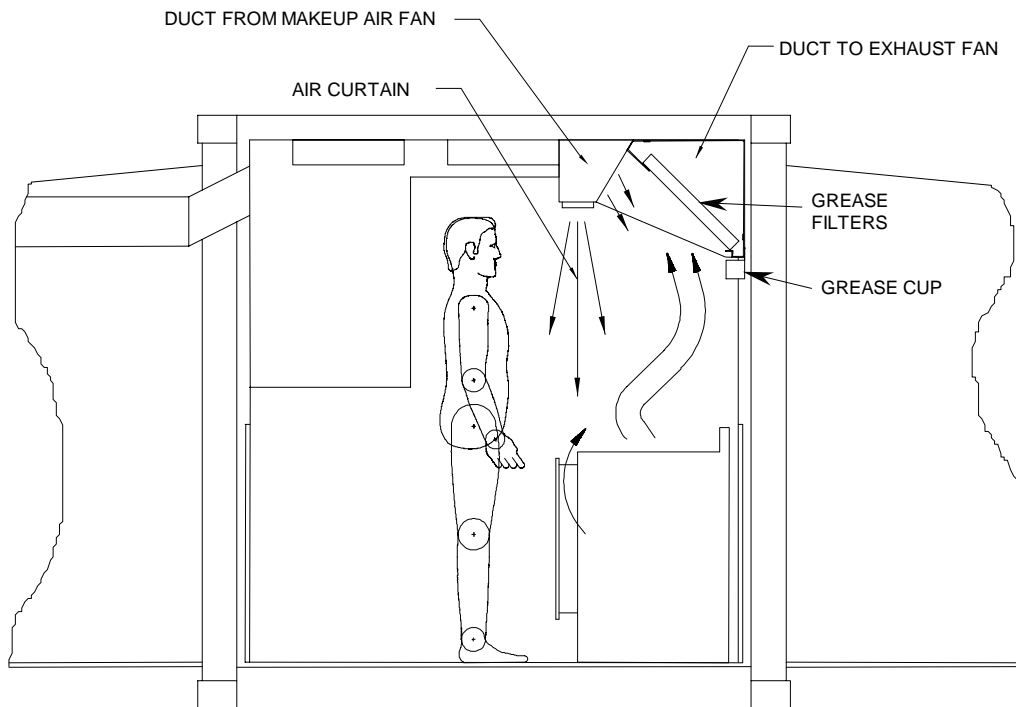

Figure 14. Cook Center Exhaust Hood.

The exhaust hood includes removable, washable, aluminum baffle-type grease filters. A tilted grease trough beneath the filters collects grease and directs it to a removable collection cup.

Air supply and exhaust are provided by two identical, variable-speed fans located in the mechanical room. Under normal conditions, the fans operate at approximately 60 to 75% capacity. The remaining capacity provides for unusual conditions when large amounts of smoke or steam must be exhausted from the kitchen.

### Environmental Control System - ECU

The Environmental Control System consists of two dual-stage air conditioners located in the mechanical room, three heating elements located in the air conditioner evaporator discharge plenum, fixed and removable ductwork, filters, and an Environmental Control Unit (ECU). Components of the ECU include a wall-mounted mode selector switch in the food preparation area and a controller mounted on the back wall inside the mechanical room.

Each air conditioner has a rated cooling capacity of 24,000 BTU/hr, and contains two independent compressors. Under the control of the ECU, the four compressors operate independently of each other to provide staged cooling capacities of 12,000 BTU/hr, 24,000 BTU/hr, 36,000 BTU/hr, and 48,000 BTU/hr. ECU operation is described in detail in WP 0003 00.

When the heaters are operating, one air conditioner fan runs to circulate the heated air. The heaters are designed to provide only limited control of kitchen temperature without overloading the generator. The principal source of kitchen heating is the MBUs during cooking operations.

---

**CONTAINERIZED KITCHEN (CK)  
EQUIPMENT DESCRIPTION AND DATA**

---

**0002 00**

Spot cooling and heating of various parts of the food preparation area is controlled by several manually adjustable vent openings in the fixed ceiling duct in the shelter core. The ECU is not designed to heat and cool the entire kitchen, but only to maintain a reasonably comfortable working environment for the cooks.

**DIFFERENCE BETWEEN MODELS**

Not applicable.

**EQUIPMENT DATA**

Length: 20 ft (6.1m)

Width: 8 ft (2.44 m)

Height: 8 ft (2.44 m)

Weight: 14,080 lb (6392 kg)

THIS PAGE INTENTIONALLY LEFT BLANK

---

**CONTAINERIZED KITCHEN (CK)  
THEORY OF OPERATION**

---

0003 00

**COOKING EQUIPMENT – MBUs**

Operation of the MBUs is described in detail in TM 10-7310-281-13&P.

The MBUs receive fuel through a refueling system which provides fuel to eight locations (five in the cook center and three in the dual oven assembly). In the mechanical room, fuel comes from a 5-gallon fuel can fitted with a fuel can adapter to which the fuel line is connected. The fuel line splits into two branches, one to the cook center peninsula and the other to a connection at the bottom of the food preparation area wall (near the access door for the generator controls). A permanently mounted fuel line assembly on the back of the oven base plugs into this connection to supply the ovens and tray pack heater.

A power converter, mounted on the wall inside the mechanical room, provides 24 VDC power for the MBUs. A permanently mounted power cable runs the length of the cook center peninsula. A permanently mounted cable on the back of the dual oven assembly plugs into an outlet in the ceiling raceway to power the MBUs for the ovens and tray pack heater. An ON/OFF, MBU POWER switch on the wall next to the cook center allows the operators to quickly shut off all MBUs.

**ELECTRICAL SYSTEM**

Input electrical power for the CK is 120/208 VAC, 60 Hz, three phase. Power is supplied from either the onboard generator or from an external source connected to the Power Entrance Panel (PEP) in the mechanical room (see WP 0002 00, Figure 5). Two sets of contactors in the PEP, operated by pushbutton switches on the Main Control Panel (MCP), connect the desired power source. Circuit interlocks prevent both sources from being connected at the same time.

The MCP displays the status of the power sources and contains the switches for source selection. It also contains the lighting controls and the emergency stop (E-Stop) switch.

The E-Stop switch uses the contactors in the PEP for emergency system shutdown. Depressing the E-Stop opens both sets of contactors, disconnecting both power sources to ensure that the distribution and control panels are completely de-energized. Contacts in the E-Stop also shut down the generator.

The Power Distribution Panel (PDP), located on the serving wing wall, receives power from the PEP and distributes it through individual circuit breakers to the various branch circuits of the kitchen.

**ENVIRONMENTAL CONTROL UNIT (ECU)**

The Environmental Control Unit circulates heated or cooled air to the occupied areas of the kitchen. Using a wall-mounted control switch, kitchen personnel select the desired operating mode (off, heat, low cooling or high cooling). The operation of this switch is described in detail in WP 0005 00.

The system draws air from the kitchen through a wall-mounted return air plenum in the food preparation area. Removable, washable filters in the plenum remove dust and other particulates. The air then passes through the air conditioners to the outlet plenum, in the

---

**CONTAINERIZED KITCHEN (CK)  
THEORY OF OPERATION**

---

**0003 00**

process being heated or cooled. From the outlet plenum, the air is distributed throughout the kitchen through fixed ductwork.

The ECU provides automatic electrical load control to maximize the amount of available air conditioning. Each of the two air conditioners has two compressors. The ECU continuously monitors total kitchen load and operates the four compressors independently to maximize cooling while keeping power consumption within the 10kW capacity of the generator. This feature also operates when the CK is using external power, limiting power consumption to 10kW regardless of the amount of external power available.

**LIGHTING**

Two switches on the MCP, INTERIOR LIGHTING and LIGHTING MODE, control the lighting circuit. When the INTERIOR LIGHTING switch is ON and the LIGHTING MODE switch is in NORMAL, the white lights are on. Placing the LIGHTING MODE switch in BLACKOUT turns off the white lights and turns on the red blackout lights.

Emergency lighting capability is included in the white light fixture nearest the personnel door. It consists of an internal, rechargeable nickel-cadmium battery, control circuit, power indicator light and a test switch. If power is lost, the light automatically comes on (or remains on if it was operating). Its internal battery, when fully charged, has enough power to operate the light at reduced illumination for at least 90 minutes, allowing the operators to evacuate the kitchen until power can be restored. The EMERGENCY LIGHT switch, located on the MCP, disconnects the battery from the light. The switch should be left ON whenever there is power to the kitchen so the battery will charge. It should be placed in OFF whenever the lights are intentionally turned off or power is removed from the kitchen. This saves the battery charge so that it is available at the next startup to provide lighting in the kitchen until the generator can be brought on line or external power connected. If the emergency light is left on long enough to drain the battery, it will take approximately 36 hours to fully recharge.

The emergency light is tested by operating the test switch on the fixture. Momentarily moving the switch causes the emergency light to come on. The switch returns to its previous position and the light goes out when the switch is released.

**WATER SUPPLY & DRAINAGE SYSTEM**

The CK potable water supply and waste water drainage systems are shown in Figure 1. Potable water is supplied from an external source such as a 400-gallon, M149 water trailer. The water is routed to the onboard sink through a 50-foot, 5/8-inch diameter supply hose made of an FDA-approved material that is safe for drinking water. The brass end couplings have 3/4-inch diameter threads - male on one end and female on the other. The male end of the hose is passed through a penetration in the side of the fabric cover and connected directly to a female connection in the back of the sink cabinet. The sink assembly is described in detail in WP 0002 00.

**CONTAINERIZED KITCHEN (CK)  
THEORY OF OPERATION**

**0003 00**

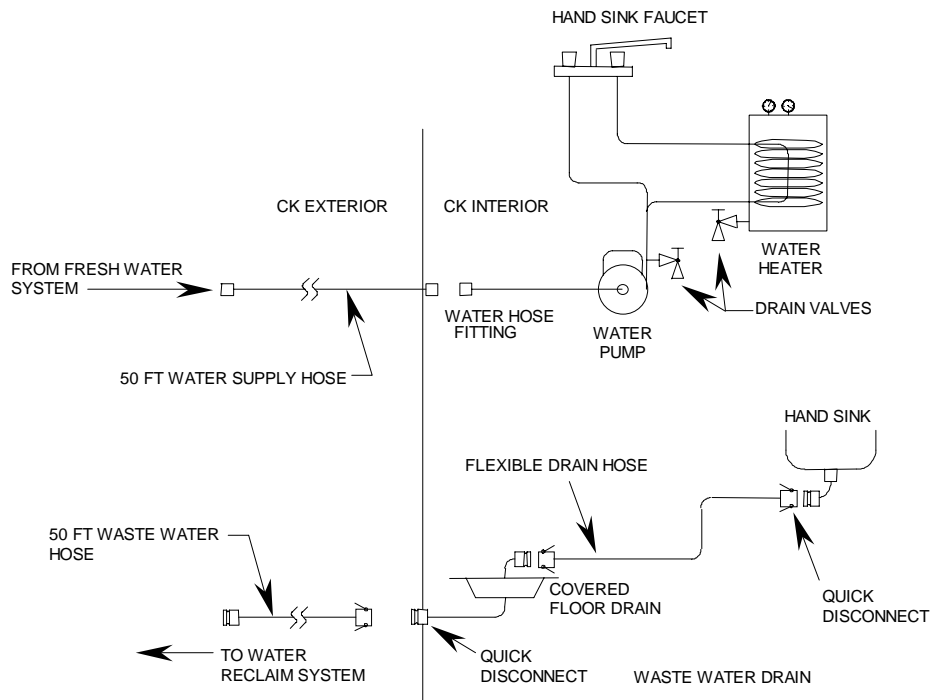

Figure 1. CK Drainage System.

Waste water from the sink is routed inside the shelter, behind the refrigerators and mobile warming cabinet, through a flexible 1.25-inch diameter interior drain hose to the floor drain near the personnel access door. The drain hose ends have quick-disconnect couplings. One end connects to the sink and the other to a fitting on the top of the shelter floor drain grate. Waste water from the floor drain and sink is piped through the shelter floor to an external 1.25-inch diameter male quick-disconnect near the personnel access door. A 50-foot, 1.25-inch diameter exterior drain hose routes the waste water from that connection to a municipal drain or external reclaiming tank. Both ends of the exterior drain hose have 1.25-inch diameter quick-disconnect couplings. During transport mode, the drain hoses are coiled and stored in the hand sink assembly. A quick-disconnect cover attached to the shelter exterior seals the external drain connection during transport.

THIS PAGE INTENTIONALLY LEFT BLANK

**CONTAINERIZED KITCHEN (CK) 0004 00**  
**SUPPORT DATA FOR REPAIR PARTS, SPECIAL TOOLS, TMDE, AND SUPPORT**  
**EQUIPMENT**

---

**COMMON TOOLS AND EQUIPMENT**

For common tools and equipment, refer to the Modified Table of Organization and Equipment (MTOE), CTA 50-970, Expendable/Durable Items, or CTA 8-100, Army Medical Department Expendable/Durable Items, as applicable to your unit.

**SPECIAL TOOLS, TMDE, AND SUPPORT EQUIPMENT**

No special tools or support equipment are required to maintain the CK. Refer to WP 0050 00 (Additional Authorization List) and WP 0052 00 (Tool Identification List) for a description of the necessary support items.

**REPAIR PARTS**

Repair parts are listed and illustrated in the Repair Parts and Special Tools List work packages, found in Chapter 6 of this manual.



THIS PAGE INTENTIONALLY LEFT BLANK

**CHAPTER 2**

**OPERATOR INSTRUCTIONS**

THIS PAGE INTENTIONALLY LEFT BLANK

---

**CONTAINERIZED KITCHEN (CK)  
DESCRIPTION OF OPERATOR CONTROLS AND INDICATORS**

---

0005 00

**INTRODUCTION**

Major controls and indicators for the CK consist of those for the generator, electrical power selection and control, lighting, MBUs, hand sink assembly, and cook center ventilation. Other miscellaneous controls include those for the mobile warming cabinet, refrigerators, oven fan, tray pack heater fan, and the environmental control unit (ECU).

**GENERATOR**

The generator control panel is located behind an access door on the food preparation side wall of the mechanical room. A detailed description of the generator's controls and indicators is provided in TM 9-6115-642-10.

**ELECTRICAL POWER CONTROL AND LIGHTING****Power Entrance Panel**

The Power Entrance Panel (PEP), Figure 1, is located on the left mechanical room wall, just inside the left door. The power cable from the external source is plugged into the connection on the PEP. The ground terminal provides a connection for the grounding rod cable when energizing the CK from the generator. Push button circuit breakers for generator, external power, and emergency stop circuit control power are located on the side of the panel. These breakers pop out when tripped, and are pushed in to reset.

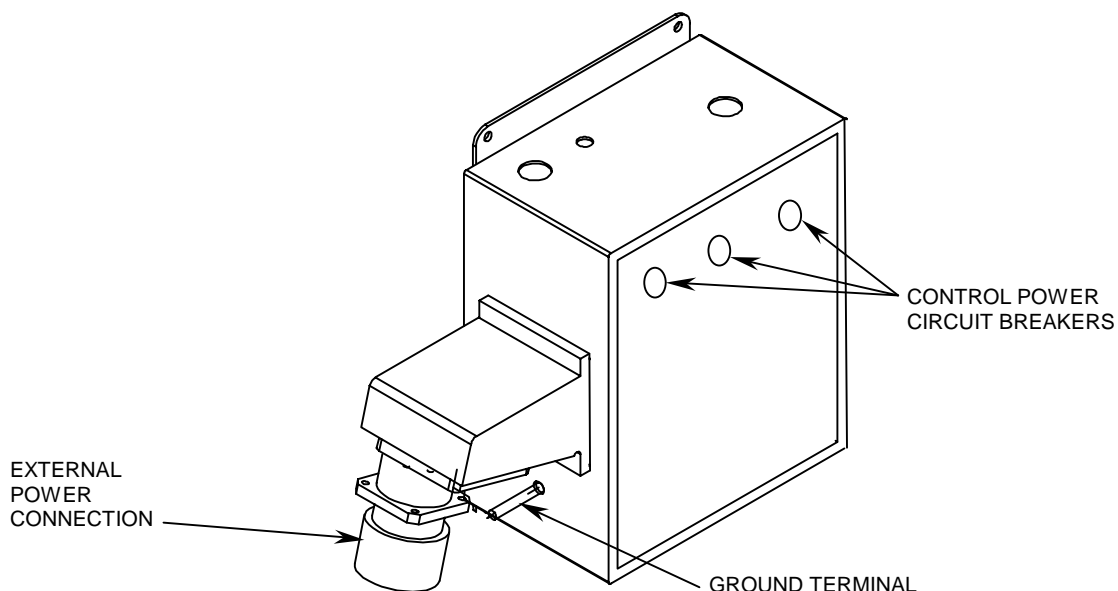

Figure 1. Power Entrance Panel.

**CONTAINERIZED KITCHEN (CK)  
DESCRIPTION OF OPERATOR CONTROLS AND INDICATORS**

0005 00

**Power Distribution Panel**

The Power Distribution Panel (PDP), Figure 2, is located on the mechanical room wall in the serving area. The panel houses the circuit breakers that control the distribution of electrical power within the kitchen. The circuit breakers are normally closed (ON) and are only opened (turned OFF) to isolate circuits for maintenance or troubleshooting. If an electrical malfunction occurs, the breaker in the affected circuit trips (opens) to isolate the affected circuit.

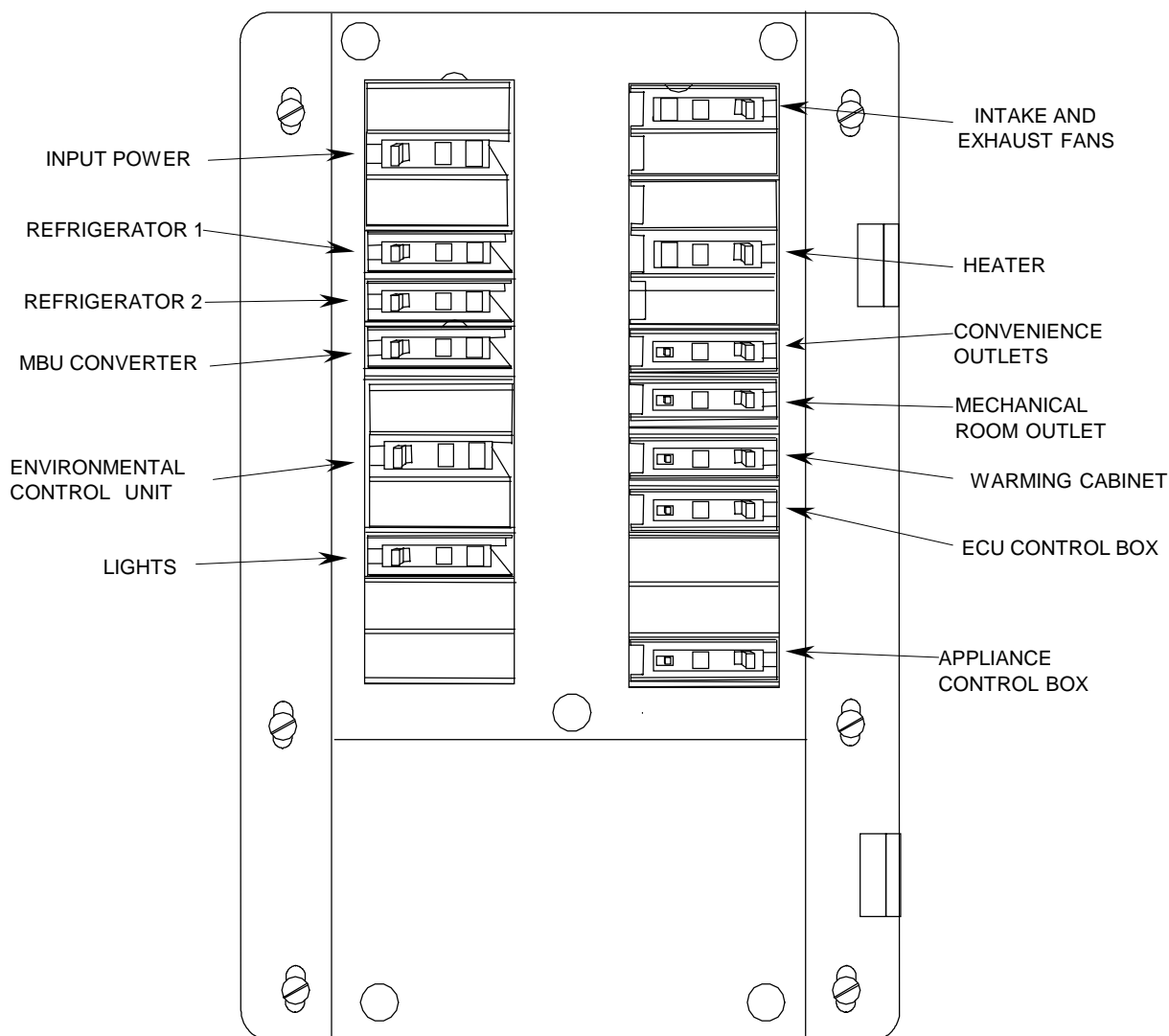

Figure 2. Power Distribution Panel.

---

**CONTAINERIZED KITCHEN (CK)  
DESCRIPTION OF OPERATOR CONTROLS AND INDICATORS**

---

**0005 00**

**Main Control Panel**

The Main Control Panel (MCP), Figure 3, is located in the food preparation area, on the wall to the right of the personnel access door. It houses the controls and indicators for selecting, connecting, and disconnecting electrical power, and for operating the CK's interior lights. These consist of the following:

- **EMERGENCY STOP (E-Stop) pushbutton:** Disconnects all electrical power from the CK in the event of an emergency. Shuts down the generator if it is running.
- **Power OFF pushbutton:** During normal operation, disconnects all electrical power from the CK. Does not shut down the generator.
- **EXTERNAL POWER ON pushbutton:** Connects external power to supply the CK. Lights green when external power is connected. Operates only if external power is available.
- **GENERATOR POWER ON pushbutton:** Connects generator power to supply the CK. Lights green when generator power is connected. Operates only if generator power is available.
- **EXTERNAL POWER AVAILABLE indicator (amber):** Lit when external power is available.
- **GENERATOR POWER AVAILABLE indicator (amber):** Lit when generator power is available.
- **INTERIOR LIGHTING switch:** Turns the interior lights ON and OFF.
- **LIGHTING MODE switch:** Selects NORMAL or BLACKOUT mode.
- **EMERGENCY LIGHT switch:** Connects (ON) and disconnects (OFF) the internal battery in the emergency lighting fixture. Whenever the kitchen is energized, the switch should be ON so the battery will charge. If the kitchen is de-energized, the switch should be turned OFF as soon as emergency lighting is no longer needed.

**CONTAINERIZED KITCHEN (CK)  
DESCRIPTION OF OPERATOR CONTROLS AND INDICATORS**

0005 00

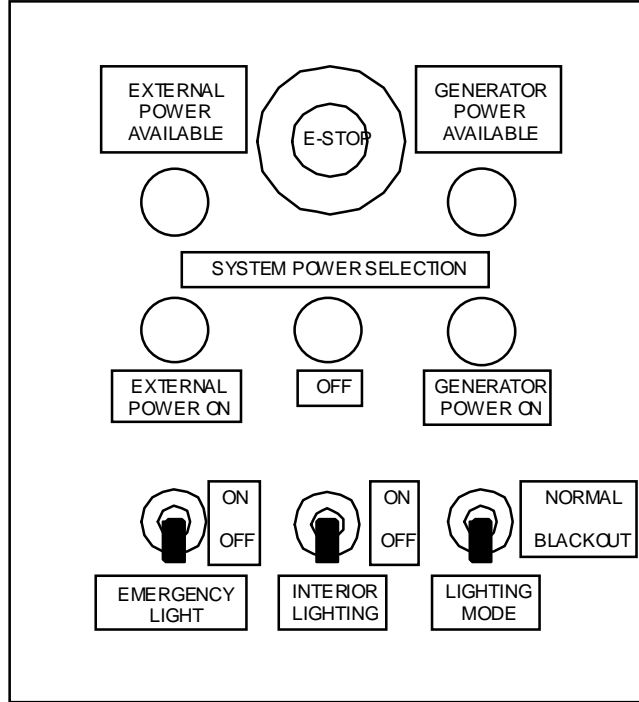

Figure 3. Main Control Panel.

**MODERN BURNER UNIT (MBU)**

**MBU Power Switch**

The MBU POWER switch, Figure 4, is located on the wall in the food preparation area, next to the spice rack. It is an ON/OFF toggle switch that controls the 110 VAC receptacle in the mechanical room that the MBU converter plugs into. Placing the switch in OFF shuts down all operating MBUs.

---

**CONTAINERIZED KITCHEN (CK)  
DESCRIPTION OF OPERATOR CONTROLS AND INDICATORS**

---

0005 00

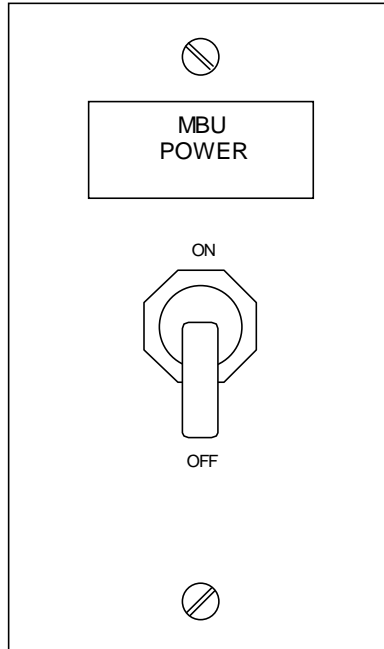

Figure 4. MBU Power Switch.

**MBU Converter**

The MBU converter, Figure 5, is mounted on the wall in the mechanical room, and has the following controls and indicators:

- MAIN POWER switch (1): Turns the converter ON and OFF.
- Output A (2): 24 VDC output connector #1.
- Output B (3): 24 VDC output connector #2.
- Indicator light (4): Lit when power is on.



**CONTAINERIZED KITCHEN (CK)  
DESCRIPTION OF OPERATOR CONTROLS AND INDICATORS**

0005 00

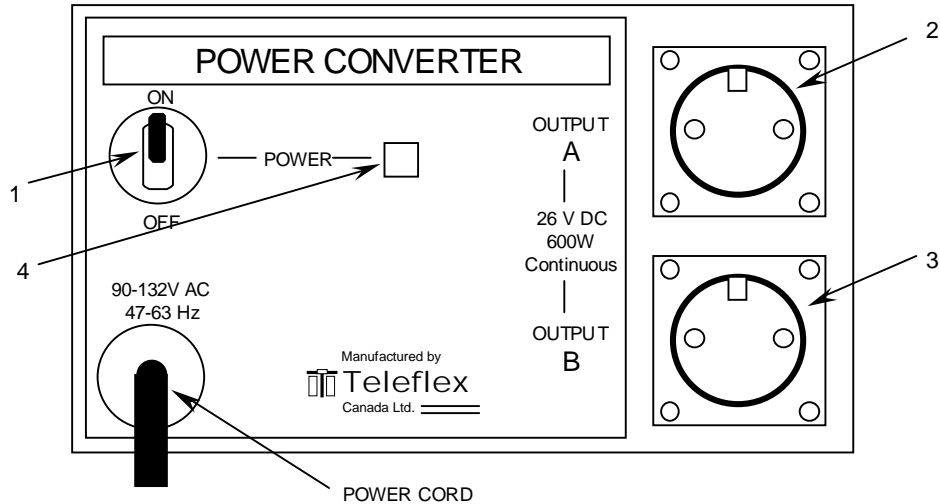

Figure 5. MBU Converter.

**MBU Control Panel**

Each MBU has an integral control panel, Figure 6. The MBU controls and indicators are listed below. Refer to TM 10-7310-281-13&P for more information about the MBUs.

- START pushbutton (1): Starts the burner.
- STOP pushbutton (2): Shuts down the burner.
- FUEL pushbutton (3): Starts the fueling function.
- POWER pushbutton (4): Turns the main power on and off.
- FIRING RATE control (5): Adjusts the burner firing rate.
- RUN indicator (6): Lights when the burner is operating.
- WARM UP indicator (7): Lights when the burner is warming up.
- FUELING/FUEL indicator (8): Lights when the tank is filling (during fueling) or full.
- LOW FUEL indicator (9): Lights when there is about 30 minutes of fuel remaining.
- VOLTAGE indicator (10): Lights when voltage from the power converter is incorrect.
- SERVICE indicator (11): Lights to indicate a malfunction.
- TOTAL HOURS indicator (12): Shows accumulated hours of operation. Displays error codes when malfunctions occur. Background light indicates power-on condition.

**CONTAINERIZED KITCHEN (CK)  
DESCRIPTION OF OPERATOR CONTROLS AND INDICATORS**

0005 00

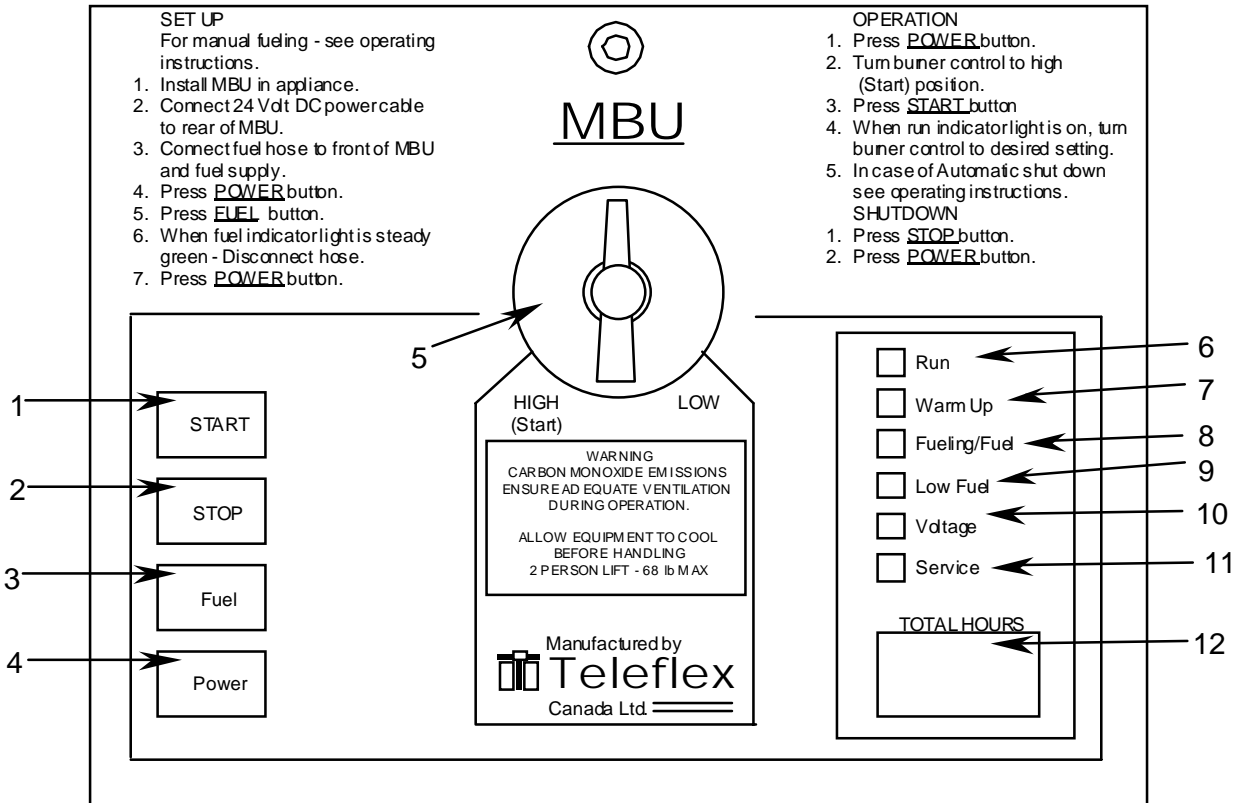

Figure 6. MBU Control Panel.

**Appliance Control Box**

The appliance control box, Figure 7, is located in the food preparation area. It is stored for packout, and is hung from one of the fabric arch supports for operation. It houses the controls for the hand sink assembly, oven fan, and tray pack heater fan. The controls include:

- WATER PUMP switch (1): ON/OFF toggle switch for the hand sink water pump.
- Circuit breakers (2): Pop out on overload. Push to reset.
- HEATER FAN switch (3): ON/OFF toggle switch for the tray pack heater fan.
- OVEN FAN switch (4): ON/OFF toggle switch for the oven fan.
- WATER HEATER switch (5): ON/OFF toggle switch for the hand sink water heater.
- Receptacles (6): Electrical connections for the appliances. Each appliance connection corresponds to the switch above it.

**CONTAINERIZED KITCHEN (CK)  
DESCRIPTION OF OPERATOR CONTROLS AND INDICATORS**

0005 00

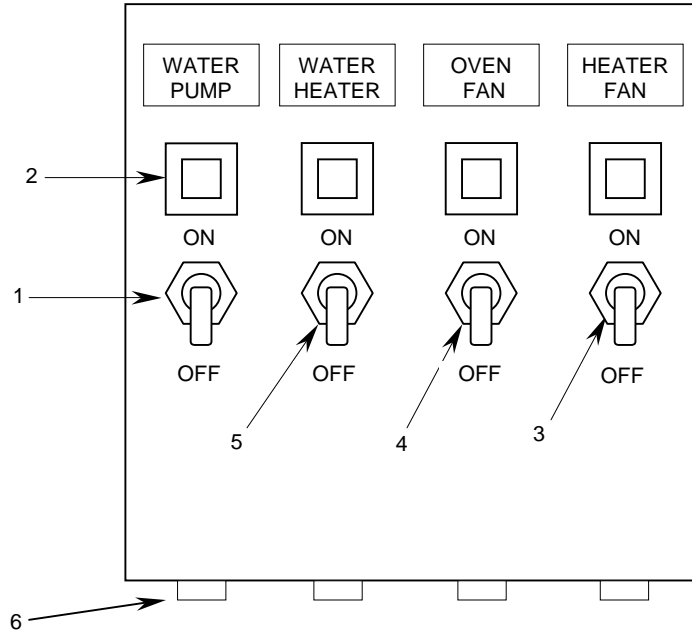

Figure 7. Appliance Control Box.

**Cook Center Ventilation**

The cook center exhaust hood intake and exhaust fans are controlled together by a single wall-mounted, rotary speed-control switch, Figure 8, located in the food preparation area (to the right of the spice rack). Rotating the control knob clockwise turns on and increases the speed of both fans. Rotating the knob fully counter-clockwise turns off the fans.

**CONTAINERIZED KITCHEN (CK)  
DESCRIPTION OF OPERATOR CONTROLS AND INDICATORS**

0005 00

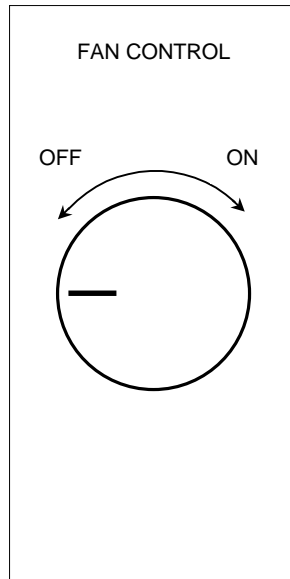

Figure 8. Cook Center Ventilation Control Switch.

**Mobile Warming Cabinet**

The controls and indicators for the mobile warming cabinet (Figure 9) are located at the bottom front of the unit and include the following:

- Power switch (1): ON/OFF rocker switch turns the cabinet on and off.
- Temperature control knob (2): Adjusts cabinet temperature setting.
- Digital thermometer (3): Shows cabinet temperature (°F)
- Yellow indicator lamp (4): Lights when the heating element is on.
- Red indicator lamp (5): Lights when the power is on.

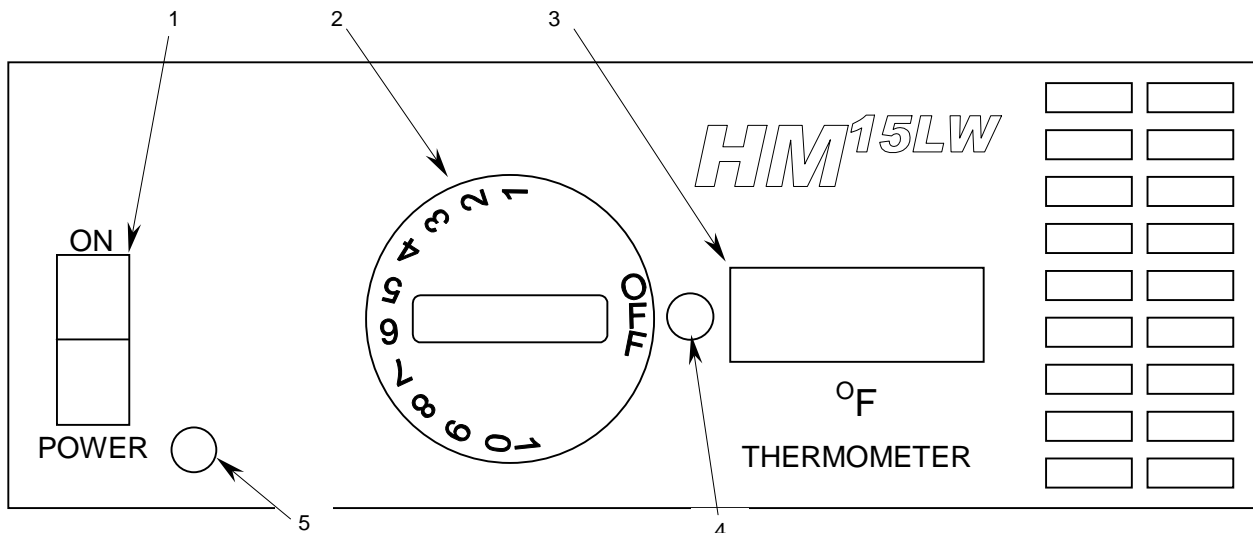

Figure 9. Mobile Warming Cabinet Controls.

**CONTAINERIZED KITCHEN (CK)  
DESCRIPTION OF OPERATOR CONTROLS AND INDICATORS**

0005 00

**Refrigerators**

Each refrigerator is controlled by a thermostat (Figure 10) located on the inside back wall of the unit. Rotating the knob clockwise lowers the temperature setting (makes the refrigerator colder). Rotating it fully counter-clockwise to OFF shuts off the unit. A small glass thermometer on the side wall of each unit shows the temperature in °F.

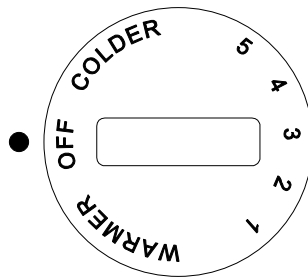

Figure 10. Refrigerator Thermostat Control.

**Environmental Control Unit (ECU)**

The ECU is controlled by a wall-mounted, four-position rotary switch (Figure 11) located to the right of the spice rack in the food preparation area. The switch positions are:

- HIGH COOL – Both air conditioners operate continuously. Compressors cycle depending upon available electrical power.
- LOW COOL – One air conditioner operates continuously.
- OFF – Environmental Control Unit is not operating.
- HEAT – Heater and one air conditioner fan operate continuously.

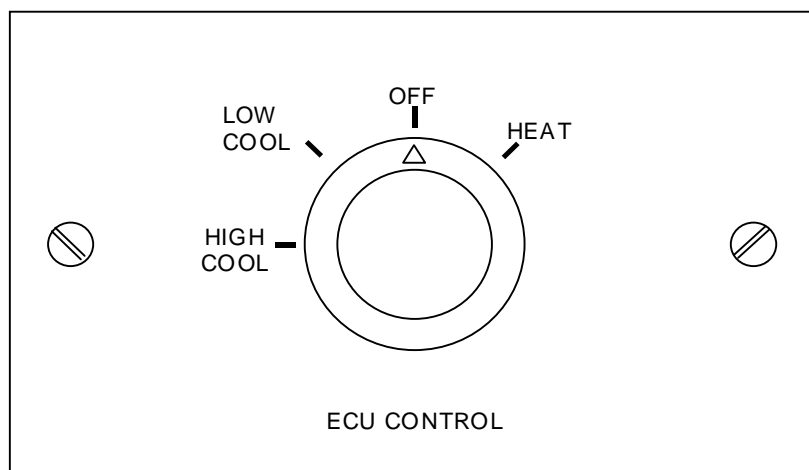

Figure 11. ECU Control Switch.

---

**CONTAINERIZED KITCHEN (CK)  
OPERATION UNDER USUAL CONDITIONS**

---

0006 00

**INITIAL SETUP:**

CK packed out

**Maintenance Level**

Operator/Crew

**Personnel Required**

Four (plus one supervisor)

**GENERAL**

When the CK arrives at the deployment site, all equipment necessary for setup and operation is packed inside the container. This work package provides step-by-step instructions for siting, leveling and expanding the container, erecting the shelter, and configuring the CK for meal preparation under usual operating conditions. Except as noted, all steps must be performed in the order given.

**SITE REQUIREMENTS**

1. If the CK is mounted on a trailer, the selected site must have a minimum of 50 ft x 30 ft of level, open space to provide maneuvering room for the tow vehicle and trailer.
2. The site must be level to a maximum elevation difference of 6 inches in 10 feet. If in doubt, consult the Operations Supervisor or Unit Commander.
3. The terrain must be firm, well drained, and relatively free of surface rocks and stones. If the soil at the site is not dry and well packed, dunnage or other support materials must be placed under the jack base plates to prevent them from sinking.
4. The slope of the terrain must not exceed 18 inches over the projected floor area of the expanded shelter (approximately 20 ft x 22 ft). If in doubt, consult the Operations Supervisor or Unit Commander.
5. If there are prevailing winds, the CK should be oriented so that exhaust gases from the onboard generator will not blow into the shelter or be drawn into the ventilation system.
6. If external electrical power will be used, the CK must be positioned within reach of the available power cable. If possible, the cable should be routed away from personnel and vehicular traffic paths. If the cable must be routed across a road or other potential vehicle path, it must be protected from damage.
7. Depending upon the makeup of the operating crew, a step aid may be required to perform some setup procedures.

**ASSEMBLY AND PREPARATION FOR USE**

1. With the tow vehicle, position the trailer in the desired location. Refer to "Site Requirements", earlier.
2. Refer to TM 9-2330-328-14&P for procedures to retrieve, install and operate the trailer leveling jacks, and to disconnect the trailer from the tow vehicle.
3. Disconnect the tow vehicle and move it out of the way before leveling the trailer.

---

**CONTAINERIZED KITCHEN (CK)  
OPERATION UNDER USUAL CONDITIONS**

---

0006 00

**Unpacking the Mechanical Room**

Before beginning to set up the CK, unpack the mechanical room as described below. The room is at the end of the container with the double doors. As items are removed, place them in convenient locations away from the sides of the CK and out of the way of personnel. Items not removed in the following steps can be left in the mechanical room until called for later in this work package.

1. Unlatch and open both mechanical room doors.
2. If the CK is on the trailer, one person shall climb into the mechanical room to assist in removing items.
3. Unstrap and remove the 8 wing jacks and remove the jacks from on top of the stair/ladders. Store the rubber straps in any convenient location in the mechanical room.
4. With one person holding the stair/ladders to prevent them from shifting, loosen the two ratchet straps.
5. Remove the 6 water cans from between the stair/ladder treads.
6. Remove the 3 stair/ladders.
7. Remove the platform and platform rail. These are located to the left of the generator.
8. Store the ratchet straps in any convenient location in the mechanical room.

**Shelter Deployment**

The CK may be mounted on its trailer or placed on the ground. Figure 1 shows the three types of jack assemblies used for deployment. If the CK is on a trailer, only the wing jacks are used. For ground deployment, all three types of jacks are used.

**Leveling the Container on the Ground****WARNING**

**Read and understand all instructions in the following paragraphs before installing or operating the jacks. Personal injury and/or equipment damage can occur if the jacks are improperly installed or operated.**

**Be careful when installing the jacks. Never allow anyone or any part of your body to be under any portion of the jacks or the container.**

**The corner and screw jacks are designed for use only with the CK. Do not use them to support or level any other container.**

1. Retrieve the two corner jack bodies, two screw jack bodies, and the two corner jack extension/base plates from their storage brackets on the left mechanical room door. The wing jacks should have already been removed when the mechanical room was unpacked.
2. Retrieve the two screw jack extension/base plates from their storage location to the left of the generator.
3. Open the personnel door. Unstrap and remove the stair/ladder railings packed just inside. Temporarily place them in a convenient location.

---

**CONTAINERIZED KITCHEN (CK)  
OPERATION UNDER USUAL CONDITIONS**

---

0006 00

4. Retrieve the jack/winch handles from their storage location on the side of the rifle rack, to the left just inside the personnel door.

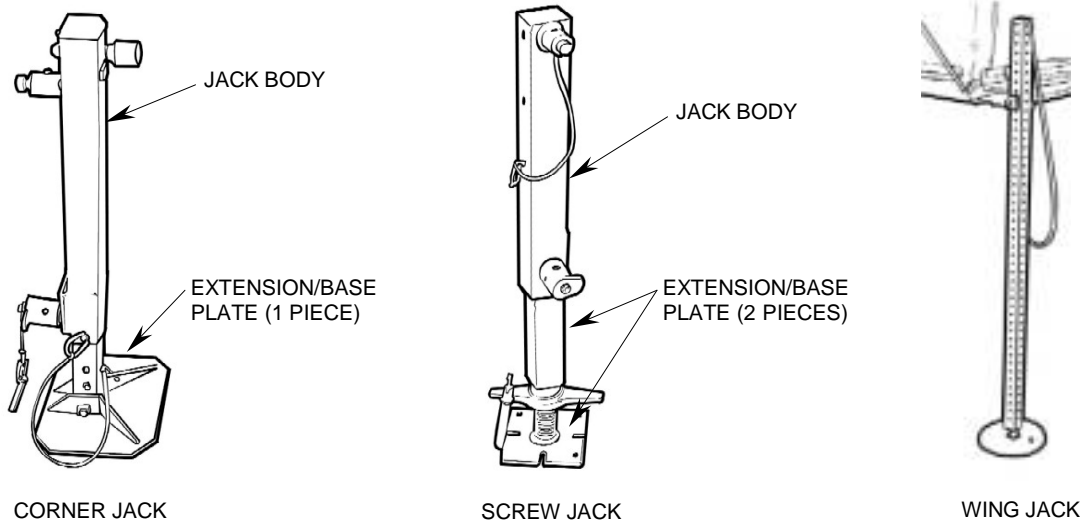

Figure 1. CK Jacks.

5. Referring to Figure 2, insert a corner jack extension/base plate into each corner jack body as far as it will go. Align the bottom hole in the extension/base plate with the hole in the jack body and insert the attached locking pin to hold the extension/base plate in place. Using a jack/winch handle, ensure that the jack mechanisms are rotated fully counter-clockwise (lowered).
6. In a similar manner, assemble the two screw jacks, ensuring that the adjustment screws are fully clockwise (lowered).
7. The corner jacks will first be installed at the personnel door end of the container. Referring to Figure 2, and starting at either corner, attach a corner jack by inserting the studs on the jack into the end holes in the corner block. Turn the twist lock on the lower stud 90° in either direction to line up one of the arrows stamped on it with the hole in the stud. Pull the jack back slightly so the twist lock contacts the inside of the corner block. Insert the attached locking pin into the twist lock.
8. Repeat step 7 for the other corner jack. Ensure that the twist locks are engaged, all locking pins are in place, and the jacks are resting parallel to the corner blocks.
9. Locate the bullseye level mounted on the end of the container in a recess in the corner block, to the left of the personnel access door. Figure 3 shows typical bubble level indications and what they mean.



---

**CONTAINERIZED KITCHEN (CK)  
OPERATION UNDER USUAL CONDITIONS**

---

0006 00

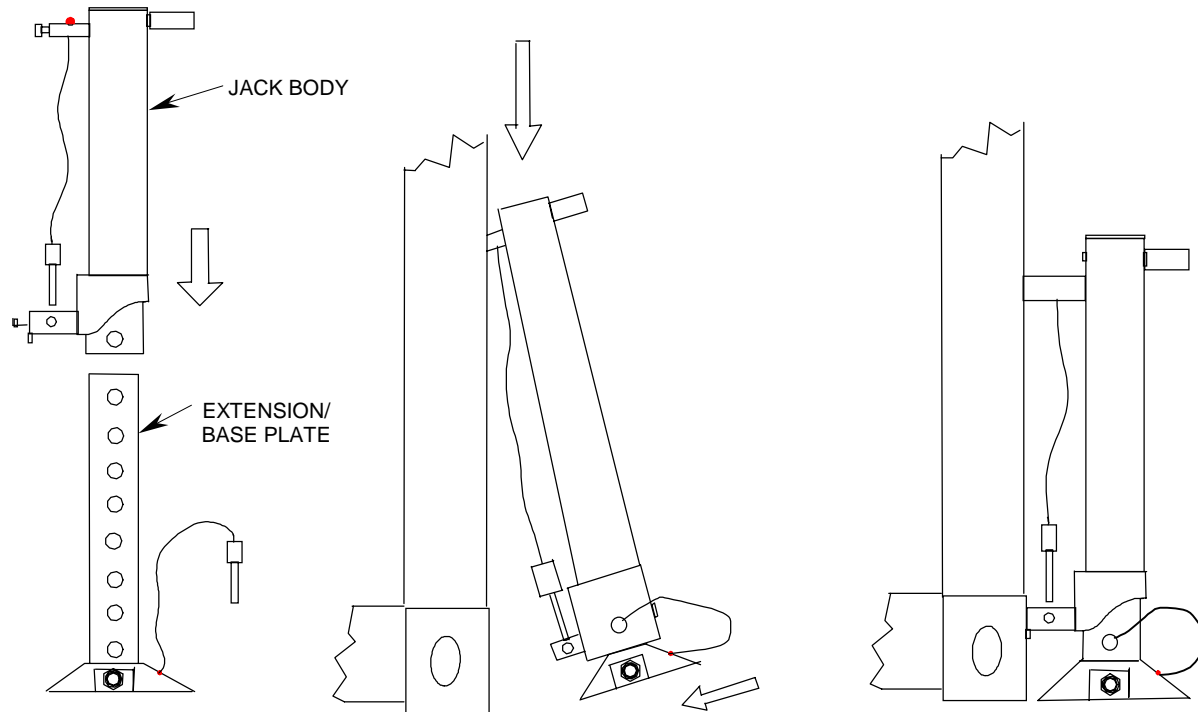

Figure 2. Corner Jack Installation.

**CAUTION**

**When raising the container, the two corner jacks MUST be operated together. Raising one jack alone can result in damage to the jacks.**

10. Simultaneously rotate the two jack handles clockwise and raise the end of the container until it is slightly higher than the opposite end. Observing the bullseye level, separately adjust the rotation rate of the jacks as necessary to level the end of the container from side to side.
11. Install the two screw jacks next to the corner jacks, in the holes on the side of the corner blocks. Raise the screw jacks until the operating screw is tight (cannot be turned by hand). Remove the corner jacks.
12. Repeating step 7 above, install the corner jacks at the opposite end of the container. Simultaneously rotate the two jack handles clockwise to raise the container. Observing the bullseye level mounted in a recess to the left of the mechanical room doors, separately adjust the rotation rate of the jacks as necessary to level the end of the container from side to side. Once the end is level, raise both corners together until the container is level from end to end.
13. Return the jack/winch handles to their storage locations on the side of the rifle rack. Strap them in place with their handle ends up.

**CONTAINERIZED KITCHEN (CK)  
OPERATION UNDER USUAL CONDITIONS**

0006 00

**Leveling the Container on the Trailer**

1. Locate the two bullseye levels mounted on the ends of the container, in recesses in the corner blocks. One is to the left of the personnel access door, and the other is at the opposite end, to the left of the mechanical room doors. Using the levels, identify the high end of the container (personnel door end or mechanical room end). Figure 3 below shows typical level indications and what they mean.

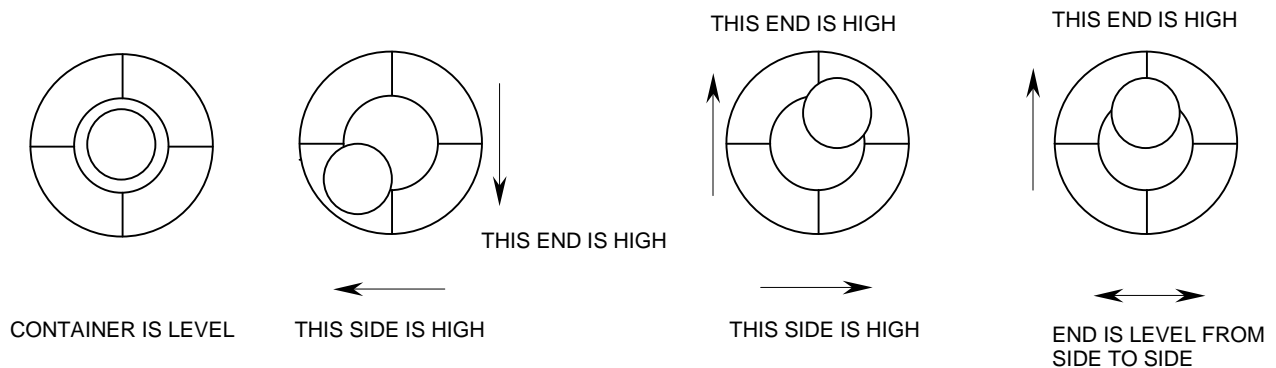

Figure 3. Bubble Level Indications.

2. At the high end, rotate the two jack handles of the trailer leveling jacks clockwise, separately adjusting the rotation rate of the jacks as necessary until the end is level from side to side.
3. Moving to the opposite (low) end, raise both corners simultaneously, adjusting jack rotation speed as necessary to level that end from side to side.
4. Continue raising the low end until the container is level from end to end.

**Shelter Expansion**

1. If not already done, open the personnel door and retrieve one of the jack/winch handles from its storage location on the side of the rifle rack.

**WARNING**

**The orange safety straps MUST be in place before unlocking the camlocks on the sides of the container. The straps are visible even when the wings are closed.**

2. Verify that the orange safety strap is attached to the serving wing (the right side when viewed from the end containing the personnel door). Climb onto the roof of the container and attach the strap if it is not (if the CK is on the ground, it will not be necessary to climb onto the roof to attach the strap). Figure 4 shows where the safety strap is located on the serving wing. It is in the same location on the food preparation wing.
3. Place three wing jacks at each wing (each corner and middle of the wing). Place the jacks approximately 8 feet out from the sides of the container.

---

**CONTAINERIZED KITCHEN (CK)  
OPERATION UNDER USUAL CONDITIONS**

---

0006 00

4. Insert the winch handle into the right winch drive slot and crank clockwise until the cable is free of slack (the winch handle becomes harder to turn). See Figure 4.

**WARNING**

**When raising or lowering the wings, one member of the crew must act as a spotter to ensure that all personnel stay clear.**

5. Crank approximately two turns counter-clockwise to release tension on the cable.
6. Turn the four cam-lock handles about 45° to partially unlock them.
7. Crank approximately 2 more turns counter-clockwise, then turn the cam-lock handles until they are at 90° (pointing straight out from the wing).

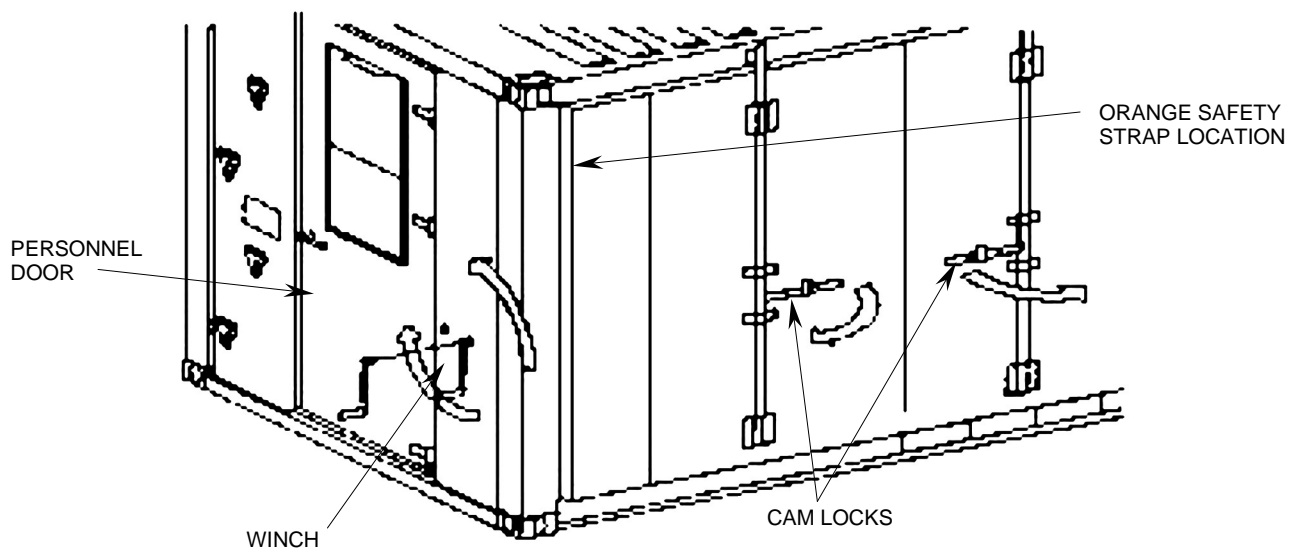

Figure 4. Shelter Expansion.

8. Crank counter-clockwise until the top of the wing is about 6 inches away from the top edge of the container.
9. Stop cranking and secure the cam-lock handles to their holders.
10. Climb onto the roof of the container and unhook the orange safety strap from the wing (if the CK is on the ground, the strap can be unhooked without climbing onto the roof).
11. Continue lowering the wing until it is level as indicated by the bubble levels attached to the edges of the wing. If the winch cable binds slightly, the wing will stop lowering and the winch handle will become easier to turn. If this happens, crank the winch in the clockwise direction for a few turns and then resume lowering the wing. Repeat this process as necessary until the wing is lowered.

**CONTAINERIZED KITCHEN (CK)  
OPERATION UNDER USUAL CONDITIONS**

0006 00

**CAUTION**

**Do not move loads onto the wing until the wing jacks are installed.**

12. Adjust each wing jack by screwing its base completely in. Align a set of holes in the jack with the bracket on the wing. Insert the locking pin through the bracket and jack. Screw the base down until it is firmly in contact with the ground.
13. Crank counter-clockwise approximately half a turn or until the weight of the wing is supported by the jacks.
14. If the CK is mounted on a trailer, install the stair/ladders and handrails at the serving wing doors. Ensure the steps rest firmly on the ground.
15. Repeat steps 2 through 13 for the food preparation wing (use the left winch drive slot). It is not necessary to climb onto the roof to unhook the orange safety strap on this wing. The strap can be reached by climbing on the fold-down steps on the end of the container.
16. Return the winch handle to its storage location on the side of the rifle rack. Strap it in place with its handle end up.

**Fabric Erection – Serving Wing**

**WARNING**

**The bags containing the shelter arch frame components weigh approximately 130 lbs (59 kg) each. Three persons must carry the bags, lifting with legs, not back, to prevent injury.**

1. Open the serving wing entrance door nearest the personnel door. Enter the serving wing, locate and retrieve the two arch frame bags.
2. Figure 5 and Table 1 below identify the frame components and the quantity of each. Unzip the bags as necessary to locate the bag containing the two curved spacers.

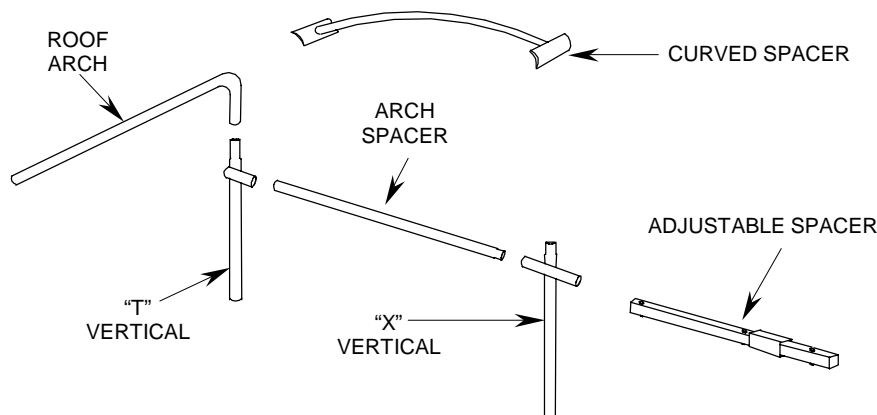

Figure 5. Shelter Frame Components.

**CONTAINERIZED KITCHEN (CK)  
OPERATION UNDER USUAL CONDITIONS**

**0006 00**

**Table 1. Contents of Shelter Frame Bags.**

<b>Component</b>	<b>Qty</b>
Roof Arch	5
“T” vertical (left side)	1
“T” vertical (right side)	1
“X” vertical	3
Arch Spacer	3 (prep side) 2 (serving side)
Adjustable spacer (2 sections)	1 (prep side)
Curved spacer (used over serving wing doors)	2

**NOTE**

**The wing floor must be level with the center core floor to ensure a correct fit for the roof arches.**

3. Assemble a roof arch and an “X” vertical as shown in Figure 6.

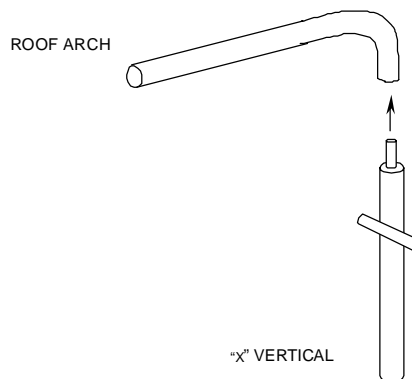

Figure 6. Center Arch Frame.

4. Position one or more personnel in the middle of the wing to push up the fabric cover and support it by hand.
5. Move onto the wing while holding the arch frame assembly.

**NOTE**

**The horizontal stubs on the verticals must face toward the inside.**

6. Starting with the center interior arch location, with other personnel supporting the fabric, rotate the arch frame assembly to insert the upper end of the arch into the arch cup at the header, as shown in Figure 7.

---

**CONTAINERIZED KITCHEN (CK)  
OPERATION UNDER USUAL CONDITIONS**

---

0006 00

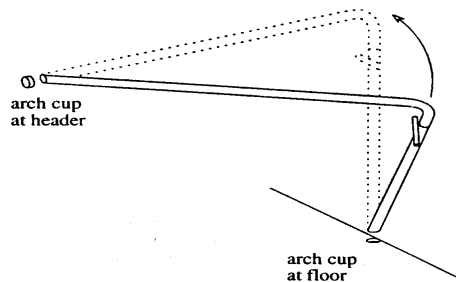

Figure 7. Arch Frame Inserted into Arch Cups.

7. Pushing lightly on the end of the assembly to hold it in the header cup, swing the assembly (keeping corner below fabric cover) until the vertical bottom end is inserted into arch cup in the floor.

**WARNING**

**Until the arch spacers are installed, the roof arches may fall.**

8. Rotate the assembly into vertical position. Some force is required once the arch contacts the fabric. Other personnel may release the fabric to help. Once in place, release the arch.
9. Repeat steps 6 through 8 for the other two central cup locations with roof arch/"X" vertical assemblies.
10. Repeat steps 6 through 8 for the two corner locations using a roof arch and a "T" vertical.

**NOTE**

**The stubs on the verticals must face toward the inside.**

11. Install arch spacers, as shown in Figure 8, between the center arch and its two adjacent arches. Slide an arch away then back to push the stub inside the spacer.

---

**CONTAINERIZED KITCHEN (CK)  
OPERATION UNDER USUAL CONDITIONS**

---

**0006 00**

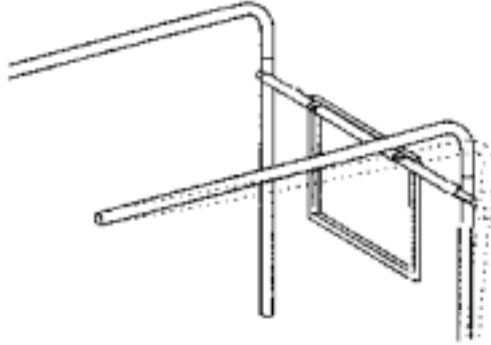

Figure 8. Arch Spacer Installation.

12. Install a curved spacer, as shown in Figure 9, over each serving wing door. Place one end of the spacer near the down-turn of the roof arch and lift up the other end against the fabric. Force the roof fabric up until the end of the spacer fits over the next arch. Position the spacers approximately 2 feet in from the doors. If desired, the doors can be held open by folding them up and wedging them between the fabric and the curved spacers.

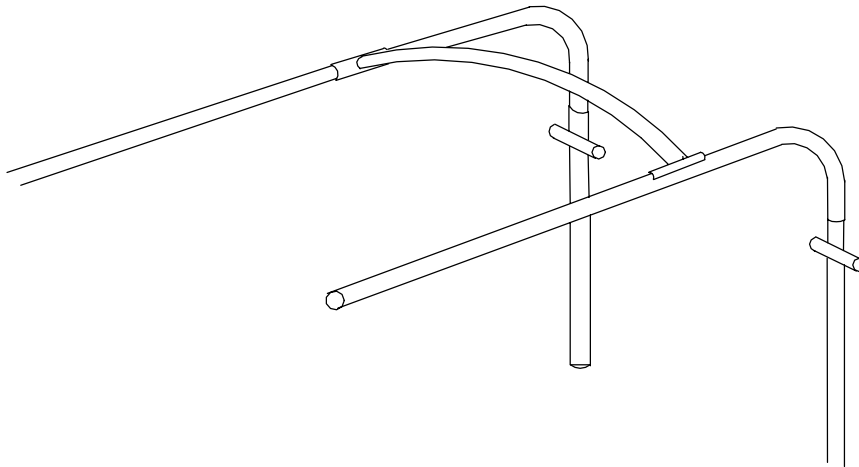

Figure 9. Doorway Support Installation.

---

**CONTAINERIZED KITCHEN (CK)  
OPERATION UNDER USUAL CONDITIONS**

---

**0006 00**

**Fabric Erection – Food Preparation Wing**

**NOTE**

**The wing floor must be level with the center core floor to ensure a correct fit for the roof arches.**

1. Unstrap the two refrigerators, unlock their casters, and move them into the serving wing to allow access to the food preparation wing. When moving a refrigerator, grasp the metal bracket on the back. Do not pull on the tube on the back of each unit.
2. Assemble a roof arch and an "X" vertical as shown in Figure 6.
3. Position one or more personnel in the middle of wing to push up the fabric cover and support it by hand.
4. Move onto the wing while holding the arch frame assembly.

**NOTE**

**The stubs on the verticals must face toward the inside.**

5. Starting with the center interior arch location, with other personnel supporting the fabric, rotate the arch frame assembly to insert the upper end of the arch into the arch cup at the header, as shown in Figure 7.
6. Pushing lightly on the end of the assembly to hold it in the header cup, swing the assembly (keeping corner below fabric cover) until the vertical bottom end is inserted into the arch cup at the floor.
7. Rotate the assembly into vertical position. Some force is required once the arch contacts the fabric. Other personnel may release the fabric to help. Once in place, release the arch.
8. Repeat steps 5 through 7 for the other two central cup locations with roof arch/"X" vertical assemblies.
9. Repeat steps 5 through 7 for the two corner locations using a roof arch and a "T" vertical.
10. Starting at the corner nearest the mechanical room, install two arch spacers, as shown in Figure 8, between the first two sets of adjacent arches. Slide an arch away then back to push stub inside spacer.
11. At the opposite corner, install an arch spacer between the first two arches.

**WARNING**

**Be careful not to pinch your fingers while installing the adjustable spacer.**

12. Install the adjustable spacer, as shown in Figure 10, in the remaining location. Slide the adjustable spacer between the stubs of the verticals. To obtain the correct tension, adjust the length by moving the bolt to the desired location. Orient the spacer so that it will tighten by pushing outward. Two personnel may be needed to straighten the spacer.
13. Apply tension to the spacer by pushing it outward to straighten. Slide the sliding tube to lock.



---

**CONTAINERIZED KITCHEN (CK)  
OPERATION UNDER USUAL CONDITIONS**

---

0006 00

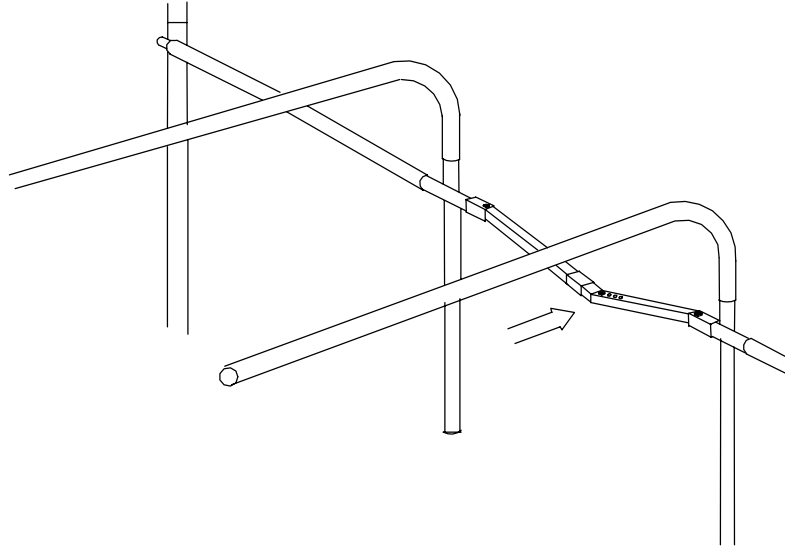

Figure 10. Adjustable Spacer.

**Mechanical Room Setup**

1. If the CK is mounted on a trailer, install the platform to provide a safe standing area for setting up the mechanical room. Hook one edge of the platform to the bracket on the end of the container and support the other edge with two wing jacks.
2. Unfurl the cloth discharge ducts for the generator, exhaust fan, and air conditioner. They should already be attached to the components via hook and loop tape at one end. Attach them if they are not.
3. Retrieve the awning from its storage location on top of the generator. Referring to Figure 11, attach the awning by screwing the four thumbscrews into the threaded holes along the top jamb of the mechanical room door frame.

**CONTAINERIZED KITCHEN (CK)  
OPERATION UNDER USUAL CONDITIONS**

**0006 00**

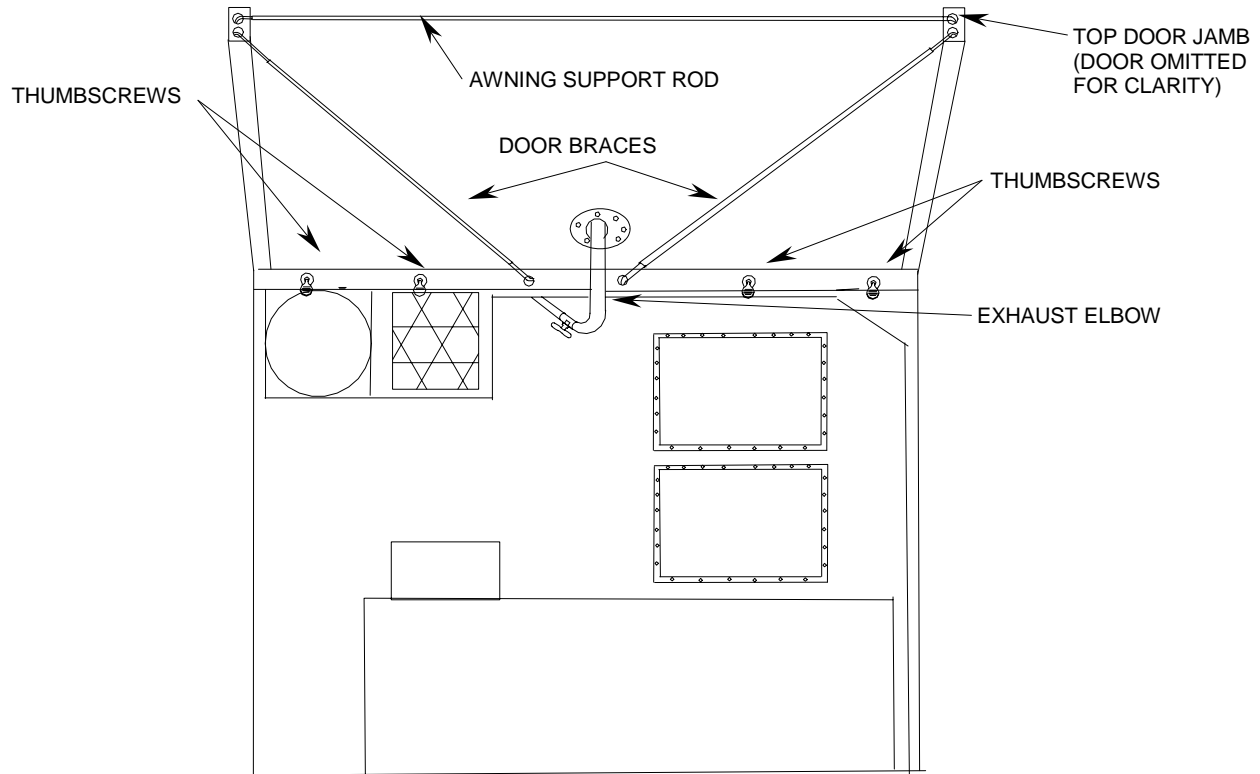

Figure 11. Awning Installation.

4. Retrieve the generator exhaust elbow pipe from its storage location to the right of the generator. Insert the open end of the pipe down through the opening in the awning from the top side. Attach the elbow pipe to the fixed exhaust pipe using the clamp coupler provided. Ensure the outlet end of the elbow pipe is pointing straight upward.
5. Retrieve the two door braces from their storage location on the floor under the air conditioners. Place the S-shaped end of one brace through one of the center two grommets in the awning and into the corresponding hole in the top door jamb.
6. Place the other end of the brace in the inner hole in the bracket on the door. The other of the two holes holds the awning support rod.
7. Repeat the previous two steps for the other door brace.
8. Retrieve the long awning support rod from its storage location on the floor. Slip the rod through the long loop on the underside of the outboard end of the awning and place the ends of the rod in the outer holes of the brackets on the doors.
9. Pull the edge of the awning over the awning support rod and buckle the straps (not shown) to the mating buckles attached to the doors.
10. Hang the ends of the three cloth discharge ducts to the door braces using the attached straps.

---

**CONTAINERIZED KITCHEN (CK)  
OPERATION UNDER USUAL CONDITIONS**

---

**0006 00**

11. Locate the ends of the two clear plastic air conditioner condensation drain hoses. Position them so the condensation drains outside of the mechanical room.
12. Retrieve the MBU fuel can adapter from its storage location to the left of the generator and install it on a filled fuel can. Place this can between the two tie-down provisions in the floor on the left side of the mechanical room. Strap the can down with one short rubber strap. Ensure the vent valve on the fuel can adapter is open.
13. Connect the hose from the fuel can adapter to the fuel connection on the left wall, underneath the Power Entrance Panel.
14. Place a second filled fuel can, with the generator fuel can adapter installed, on the ground outside of the mechanical room.
15. Uncoil the generator's auxiliary fuel line from its storage location to the left of the generator and connect it to the fuel can adapter.
16. If the platform was installed outside the mechanical room in step 1, remove the platform and the two wing jacks.

**Platform Installation**

If the CK is on the trailer, install the platform at the personnel door as follows:

1. Close the personnel door.
2. Hook the edge of the platform over the bracket under the door and rest the platform on the trailer tongue.
3. Attach the two wing jacks to the platform.
4. Install the platform rail.
5. Install the stair/ladder and stair rail.
6. If desired, open the personnel door and hold it open using a short rubber strap.

**Grounding**

If the CK is to be energized from the onboard generator, the ground rod must be installed and the ground cable connected as described below. If the CK is to be energized from external power, it will be automatically grounded through the power source, and the following steps need not be performed.

1. Remove the ground rod from its storage location next to the Power Entrance Panel inside the mechanical room.
2. Using the slide hammer (WP 0050 00, Table 1), drive the ground rod at least 8 feet into the earth at a suitable location that is near enough for the grounding cable to reach from the rod to the grounding terminal on the Power Entrance Panel (the cable is approximately 8 ft long).
3. Connect one end of the grounding cable to the ground rod using the clamp provided. Ensure that the connection is tight.

---

**CONTAINERIZED KITCHEN (CK)  
OPERATION UNDER USUAL CONDITIONS**

---

0006 00

4. Connect the other end of the grounding cable to the grounding terminal on the Power Entrance Panel. Ensure that the connection is tight.

**Energizing the CK from the Onboard Generator**

The following procedures should be followed to properly and safely supply power to the kitchen from the generator. While the generator is capable of taking the full load of the kitchen appliances and utilities all at once, it is not recommended that all loads be turned on at the same time. The following procedures allow the kitchen to be brought on line safely and effectively. Except as noted, the applicable controls and indicators are located on the Main Control Panel, shown in Figure 12.

**CAUTION**

**If appliances have been moved into position before energizing the onboard generator, ensure that the switches for the water pump and water heater are left OFF until the water system and water heater are filled. Energizing these components without water in them will result in equipment damage. Also turn off the lights, exhaust fans, and oven fan. The refrigerators may be plugged in and turned on, and the Environmental Control Unit (ECU) has a built in time delay and may be left on.**

1. From the generator control panel, start the generator and close its output contactor (AC Circuit Interrupter) in accordance with the procedures in TM 9-6115-642-10.
2. Verify that the amber GENERATOR POWER AVAILABLE indicator is lit.
3. If the EXTERNAL POWER ON indicator is lit, press the black System Power OFF button and verify that the light goes out. This ensures that the kitchen is de-energized before applying generator power.

**CAUTION**

**Before applying generator power, ensure that the kitchen is properly grounded as described in "Grounding", above.**

4. Press the GENERATOR POWER ON pushbutton and verify that it lights green.

---

**CONTAINERIZED KITCHEN (CK)  
OPERATION UNDER USUAL CONDITIONS**

---

0006 00

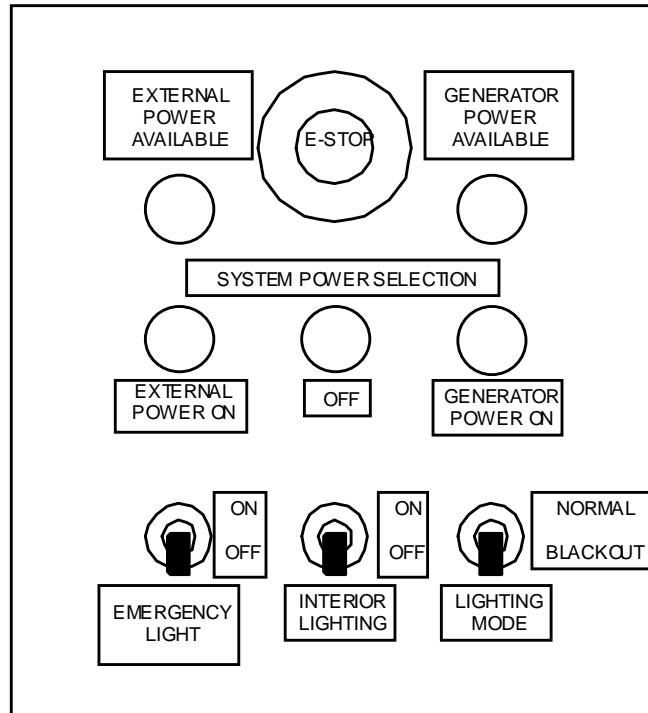

Figure 12. Main Control Panel.

5. Turn the EMERGENCY LIGHT switch to ON to charge the emergency lighting battery. If desired, turn on the lights using the INTERIOR LIGHTING switch.
6. Turn on the ECU and the cook center ventilation fans as desired. Their controls are located next to the spice rack. Position the ECU control switch to the desired operating mode.

### Energizing the CK from External Power

The CK can be operated from an external 120/208VAC, 60-amp, 3-phase power source. A cable from the external source must be provided. The cable should be attached to the receptacle on the Power Entrance Panel located on the left wall in the mechanical room.

### CAUTION

**If appliances have been moved into position before energizing external power, ensure that the switches for the water pump and water heater are left OFF until the water system and water heater are filled. Energizing these items without water in them will result in equipment damage.**

1. Turn off the water pump and water heater at the appliance control box unless the water system is charged and the water heater is full.

---

**CONTAINERIZED KITCHEN (CK)  
OPERATION UNDER USUAL CONDITIONS**

---

0006 00

**WARNING**

**Do not attempt to connect an energized cable to the Power Entrance Panel.**

2. Ensure that external power is turned off at its source, then connect the cable at the Power Entrance Panel.
3. Connect the opposite end of the cable to the source, if not already connected, and energize the source. Verify that the amber EXTERNAL POWER AVAILABLE indicator is lit.
4. If the GENERATOR POWER ON indicator is lit, press the System Power OFF pushbutton and verify that the light goes out. This ensures that the kitchen is de-energized before applying external power.
5. If it is running, shut down the generator as described in TM 9-6115-642-10.
6. Disconnect the ground cable from the ground terminal on the Power Entrance Panel.
7. Press the EXTERNAL POWER ON pushbutton and verify that it lights green.
8. Turn the EMERGENCY LIGHT switch to ON to charge the emergency lighting battery. If desired, turn on the lights using the INTERIOR LIGHTS switch.
9. Turn on the ECU and the cook center ventilation fans as desired. Their controls are located to the right of the spice rack. Position the ECU control switch to the desired operating mode.

**Appliance and Equipment Relocation**

The CK is shipped with most of its appliances and associated equipment tied down so that they are not damaged during shipment. These items must be relocated to their designated operating positions as described below. The refrigerators should have already been moved into the serving wing to allow access for erecting the shelter on the food preparation wing.

Before moving items with casters, ensure that the casters are unlocked.

After unstrapping and positioning the various items, store the straps on the hanger bars on the food preparation side wall of the mechanical room.

As the electrical appliances and lights are positioned in the following steps, they are plugged into designated outlets in the raceway located in the ceiling of the shelter core. These outlets are shown in Figure 13. If necessary, appliances and other items may be temporarily moved to reach the plugs.

**CONTAINERIZED KITCHEN (CK)  
OPERATION UNDER USUAL CONDITIONS**

0006 00

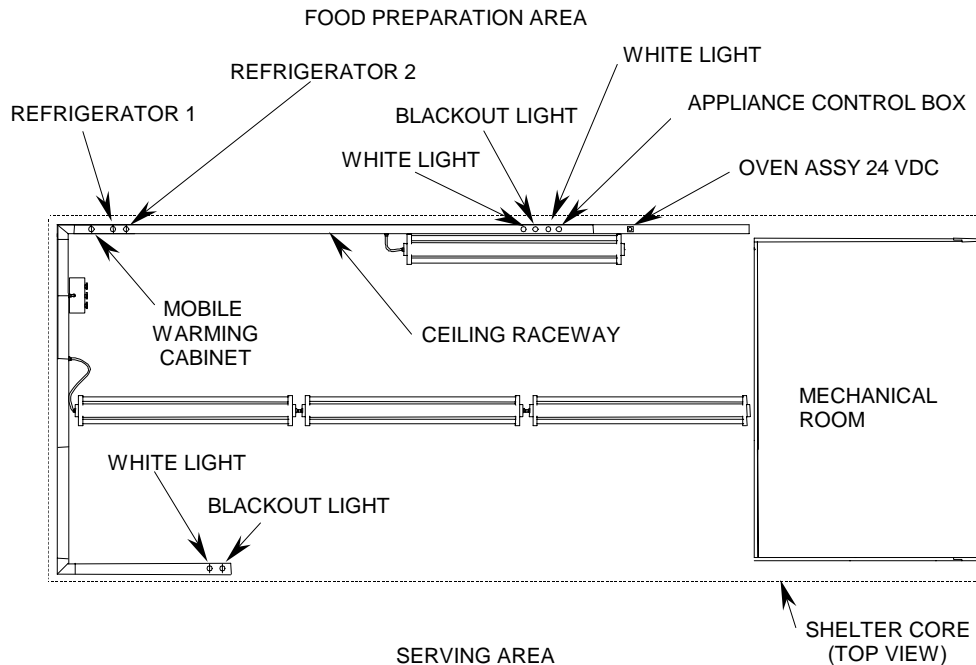

Figure 13. Ceiling Raceway Electrical Connections.

**WARNING**

**Use caution when moving appliances and equipment in the following steps, to avoid pinching hands or fingers.**

1. Unstrap the sink assembly and move it to approximately its operational position under the window nearest the personnel door in the food preparation wing.
2. Unstrap the two mobile storage cabinets and move them to the serving wing.
3. Remove the water supply and drain hoses from the lower shelf and back of the sink assembly.
4. At the back of the sink assembly, attach one end of the 15-foot internal drain hose to the sink drain and the other end to the fitting on the floor drain by the personnel door. Route the hose close to the walls.
5. Remove the dust cap from the exterior drain fitting at the base of the shelter, to the left of the personnel door. Attach the 50-foot external drain hose to the fitting. Attach the other end to the water collection facility.
6. From outside, feed the male end of the water supply hose through the smaller of the two penetrations below the window in the food preparation wing. Ensure that the hose washer on the sink fitting is in place. Connect the hose to the fitting. Connect the other end of the hose to the water source.

---

**CONTAINERIZED KITCHEN (CK)  
OPERATION UNDER USUAL CONDITIONS**

---

**0006 00**

7. Uncoil the water heater and water pump power cables from the back of the sink assembly and temporarily drape them across the top of the assembly.
8. Roll up the window flap behind the sink location and secure it with the strap provided.
9. Position the sink assembly in its operational position and lock the front casters.
10. If it will not be needed to fill the steam table or tray pack heater, repack the 25-ft water supply hose on the bottom shelf of the sink assembly.
11. Unstrap the mobile warming cabinet and move it to its operational position in the food preparation wing, against the positioning rail on the floor. Place it as tightly in the corner as possible and lock the front casters. Connect its power cord to the marked receptacle on the ceiling raceway in the center core of the kitchen.
12. Unstrap and move the dual oven assembly to approximately its operational location in the corner of the food preparation wing. Retrieve the chimney pipe from its storage location in one of the drawer assemblies in the oven base and attach it to the outlet of the oven fan. Orient the pipe so its outlet points downward.
13. Carefully guiding the chimney pipe through the opening in the wall, locate the oven assembly against the positioning rail on the floor. Lock the front corner casters.
14. Uncoil the fuel line on right side of the oven assembly. Lead it along the floor against the end wall, remove the dust caps, and attach it to the fuel supply fitting at the base of the mechanical room wall.
15. Uncoil the longer of the two power cables on the left side of the oven assembly. Lead it up the arch to its marked receptacle on the ceiling raceway. Plug in the cable and secure it to the arch using the hook and loop ties provided.
16. Retrieve the appliance control box from its storage location in one of the drawer assemblies. Hang it from the horizontal spacer bar just to the right of the center arch. Lead the power cable up along the arch to its marked receptacle on the ceiling raceway. Plug in the cable and secure it to the arch using the hook and loop ties provided.
17. Verify that the four switches on the appliance control box are OFF. Plug the power cables for the water pump, water heater, and oven fan into their respective outlets on the bottom of the box.

**CAUTION**

**Ensure that no power cables are touching the tray pack heater or the oven. They could become damaged and result in a fire or shock hazard.**

18. Secure the excess lengths of cable between the fabric and the spacer bar.
19. Unstrap and remove the burner rack and base rack from on top of the tray pack heater. Place them in a convenient location the serving wing.
20. Roll up the window flap next to the oven assembly and fasten it in place with the strap provided.
21. Unstrap and move the tray pack heater to near its operational location next to the ovens.



---

**CONTAINERIZED KITCHEN (CK)  
OPERATION UNDER USUAL CONDITIONS**

---

**0006 00**

22. Remove the heater fan assembly from inside the tray pack heater and mount it in its bracket on the back of the unit. Route the exhaust pipe through its penetration in the shelter wall, orienting the pipe so its outlet points downward.
23. Attach the fuel line and power cable at the left of the ovens to the MBU in the tray pack heater. Plug the heater fan cable into its designated outlet on the appliance control box.
24. Position the tray pack heater against the ovens and the positioning rail on the floor, and lock the front casters.

**CAUTION**

**When moving a refrigerator, use the metal bracket on the back. Do not grasp the plastic tube running down the back of the unit or it may be damaged.**

25. Move the right-hand-hinged refrigerator to its operational location next to the mobile warming cabinet. Position the refrigerator against the positioning rail on the floor and lock the front casters. Connect its power cord to the Refrigerator No. 1 receptacle on the ceiling raceway.
26. Position the left-hand-hinged refrigerator near its operational location next to the other refrigerator and connect its power cord to the Refrigerator No. 2 receptacle on the ceiling raceway. After it is plugged in, line up the refrigerator so that the fronts of the two units are even with each other. Lock the front casters.
27. Remove the ratchet strap from the right half of the cook center. Remove the three insulated food transporters and store them in any convenient location.
28. Remove the ratchet strap from the left half of the cook center. Remove the two insulated food transporters and store them in any convenient location.

**WARNING**

**The packed light storage box weighs approximately 100 lbs (45.4 kg). Three persons must carry the box, lifting with legs not back, to prevent injury.**

29. Remove the light storage box from on top of the cook center and place it in any convenient location on the floor of the serving wing.

**NOTE**

**The two tables used in the food preparation area receive utility drawers, the two used in the serving area do not. All four tables have the drawer mounting hardware and are interchangeable.**

30. Remove the two tables from the left side of the cook center, unfold their legs, and place them in the serving wing. Position them against the sidewall between the doors. Store the burner rack and base rack under the tables.

---

**CONTAINERIZED KITCHEN (CK)  
OPERATION UNDER USUAL CONDITIONS**

---

**0006 00**

31. Remove the cook pot cradle adapters stored in the blanket from the cook center and store them under the tables. Remove the moving blanket and set it aside in a convenient location.
32. Remove the remaining two tables from the cook center, unfold their legs, and place them in the center of the food preparation wing. They may be placed in any convenient position as desired.
33. Retrieve the two drawer assemblies from their storage locations at the bottom of the dual oven assembly.
34. Temporarily empty the drawers, placing the removed items on the tables. From underneath, attach a drawer to each table by screwing the captive screws on the drawer slides into the fittings on the table. Place the utensils back in the drawers as desired. Store the remaining miscellaneous kitchen items as desired. The knives should already be stored in the knife rack on the side of the sink assembly.
35. Position the mobile storage cabinets against either wall of the serving area as desired.

**CAUTION**

**Do not place filled beverage dispensers or other heavy items in the mobile storage cabinets. Damage to the cabinets will result.**

36. Remove the insulated food transporters from the refrigerators and mobile warming cabinet and store them in any convenient location. Place the spare tray slides back inside the mobile warming cabinet.

**NOTE**

**The griddle, steam table, and cook pot cradle adapters are interchangeable and can be used on either half of the cook center peninsula.**

37. Set up the cook center with the griddle and splash guards, the steam table and adapter top, or the cook pot cradle adapters and cook pot cradles, as desired. Any of these items can be set up on either half of the cook center. If the griddle is used, the splash guards must be retrieved from the light storage box and installed on the griddle.
38. Retrieve any loose tie-down straps and store them on the hanger bars on the wall in the food preparation area.

---

**CONTAINERIZED KITCHEN (CK)  
OPERATION UNDER USUAL CONDITIONS**

---

0006 00

**Ceiling Light Installation****WARNING**

**In the event of lamp breakage, be careful in removing glass fragments and white phosphorous dust that may be dispersed from the fixture. Handling glass fragments or inhaling phosphorous dust could cause personal injury.**

1. Unpack the removable light fixtures from their storage box and position them as shown in Figure 14. Install the lights by slipping the hooked brackets at the ends of the fixtures between the fabric and the arches. Orient each fixture so the end with the power cord is toward the designated receptacle.
2. Plug the power cords into their marked receptacles in the ceiling raceway.
3. Tuck the excess cable between the fabric and the arches.
4. Place the two arch frame component bags and the moving blanket in the light storage box. Store the box under the tables in the serving wing or in another convenient location as desired.

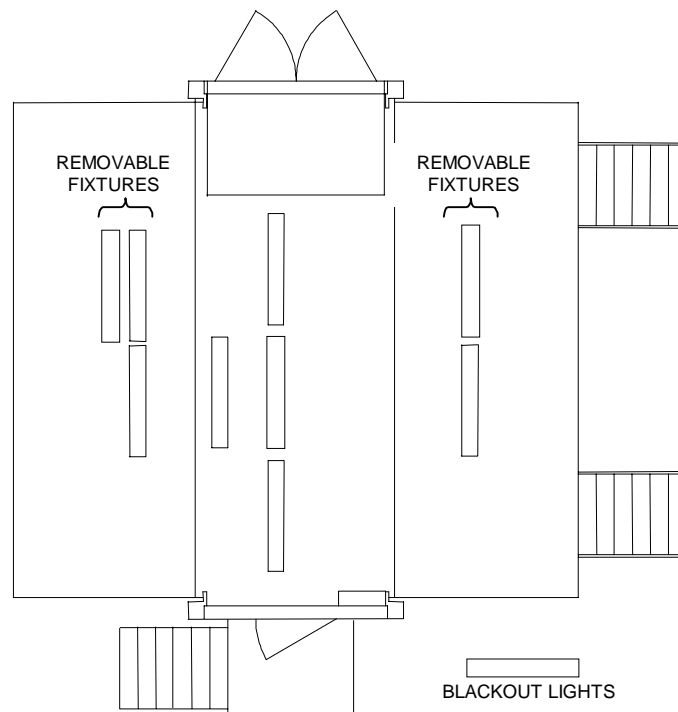

Figure 14. Ceiling Light Fixture Layout.

---

**CONTAINERIZED KITCHEN (CK)  
OPERATION UNDER USUAL CONDITIONS**

---

**0006 00**

**Water and Drain System Startup**

The water supply hose, internal drain hose, and external drain hose should already be connected as described earlier in this Work Package. Fill the water system as follows:

**CAUTION**

**The switches for the water pump and water heater (located on the appliance control box) must be left OFF until the water system and water heater are filled. Energizing these items without water in them will result in equipment damage.**

**In freezing weather, the water tank trailer should be located as close to the fabric penetration as possible. Additional procedures to prevent freezing are described in WP 0007 00.**

1. Ensure that both drain valves in the sink assembly are fully closed. The valves are located at the back of the assembly under the water heater – one for the heater and one for the cold water line. If necessary, unlock the sink assembly casters and temporarily move the sink assembly to check the valves.
2. Open the hot and cold water handles to eliminate back pressure on the pump.

**CAUTION**

**Do not run the water pump for more that approximately one minute without water. If water is not running from the faucet after this time, shut off the pump at the appliance control box and check for kinks or leaks in the supply hose. The water heater must be left OFF until it has been filled.**

3. Position the WATER PUMP switch on the appliance control box to ON.
4. Turn off the cold water when a steady stream of water runs from the faucet. After a short time for the water heater to fill, turn off the hot water when a steady stream runs from the faucet. After the water is turned off, the pump will automatically stop after a few seconds.
5. Position the WATER HEATER switch on the appliance control box to ON.
6. To fill the tray pack heater or steam table, retrieve the short water supply hose from the base of the sink assembly, connect the female end to the faucet, and fill these items as desired. When no longer needed, drain the hose, coil it, connect its ends together to minimize the possibility of contamination, and restow it in the sink assembly base.

---

**CONTAINERIZED KITCHEN (CK)  
OPERATION UNDER USUAL CONDITIONS**

---

0006 00

**KITCHEN OPERATION**

**Generator**

A detailed description of generator operation is provided in TM 9-6115-642-10.

**Modern Burner Units**

A detailed description of MBU operation is provided in TM 10-7310-281-13&P. Check that the MBU POWER switch is ON before attempting to start the MBUs. To ensure sufficient air flow for MBU ignition, the cook center ventilation fans should be running before lighting any MBUs in the cook center. Also, when lighting the two MBUs in either section of the cook center, the right-hand MBU in each section should be lit first. The MBUs in the dual oven assembly can be lit in any order.

**Environmental Control Unit**

Operation of the Environmental Control Unit is fully automatic once the desired mode is selected with the ECU control switch. The available modes are off, low cooling, high cooling, and heat. The system operates until it is turned off; there is no temperature setpoint adjustment.

**NOTE**

**The Environmental Control Unit has time delay features that cause several minutes delay before the system starts, and each time the control switch position is changed. If the system does not start after approximately five minutes, reset the control circuit by cycling the controller's circuit breaker (#18 on the Power Distribution Panel) OFF and back ON.**

**Exhaust Hood Ventilation**

Exhaust hood ventilation is controlled by the fan speed control located to the right of the spice rack. Rotate the knob clockwise to increase fan speed and counter-clockwise to reduce it. Turning the knob fully counter-clockwise shuts off the fans. The exhaust system should not normally be operated above about 75% fan speed (control knob turned clockwise approximately  $\frac{3}{4}$  of its travel) as this is enough to exhaust smoke and steam generated at the cook center under normal cooking conditions. The remaining capacity is available if needed to exhaust unusually large amounts of smoke or steam; however, operating the fans at higher speed increases the noise level in the kitchen and is not recommended unless necessary.

**CONTAINERIZED KITCHEN (CK)  
OPERATION UNDER USUAL CONDITIONS**

0006 00

**KITCHEN PACKOUT AND PREPARATION FOR TRANSPORT**

**Introduction**

The ISO expandable shelter serves as the primary container for the CK. Upon completion of an operational deployment, the CK is packed for transport within the shelter. All components must be packed in the order and locations specified in the following paragraphs to ensure that everything will fit and to prevent damage during transport.

The packout procedures which follow assume that all foodstuffs and other items not part of the CK's inventory will be removed before initiating packout. In specific tactical situations, however, the Unit Commander or Unit Standard Operating Procedures may direct that the CK be packed out and moved with food or other items on board. In such cases, the packout procedures may be locally modified as required.

When a ratchet strap is called for, place the long section of the strap toward the mechanical room and the short ratchet section toward the personnel door. Ensure that the straps are straight. Tighten the straps slightly, move the piece of equipment slightly to ensure that the straps are secure, then completely tighten the straps.

Figure 15 illustrates the packout locations of the appliances and other major components. Table 2 provides a checklist of the loose items and gives the recommended packout location of each item. Further information and instructions for packout are provided in the following paragraphs.

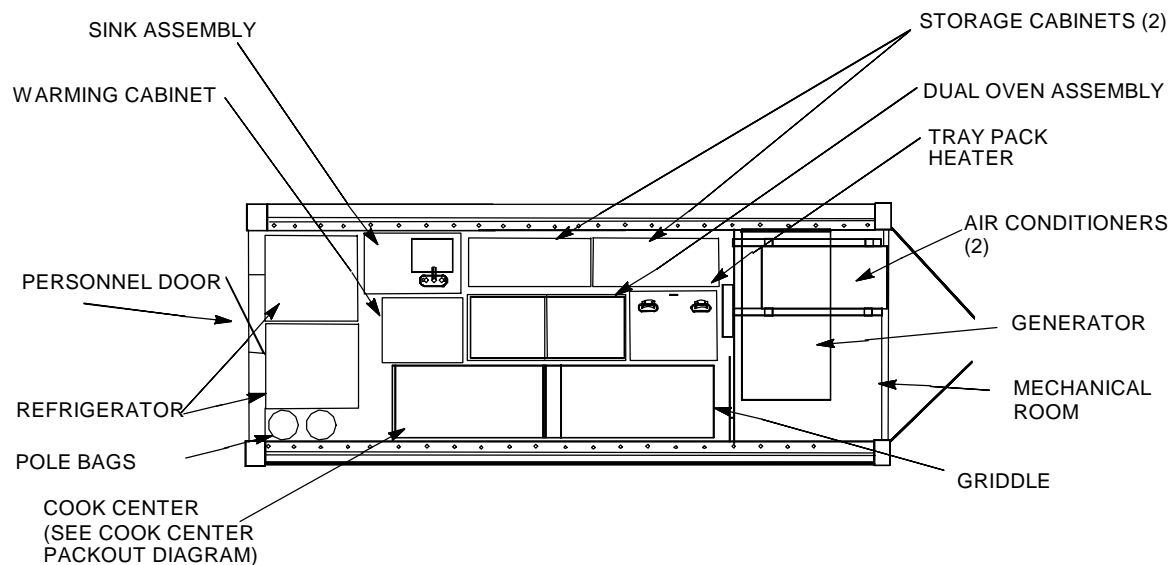

Figure 15. Major Component Packout Locations.

---

**CONTAINERIZED KITCHEN (CK)  
OPERATION UNDER USUAL CONDITIONS**

---

0006 00

**Preparation for Packout**

Before beginning packout, prepare the CK as follows. Except as noted, these steps may be performed simultaneously or in any convenient order.

**WARNING**

**Ensure that all CK components have completely cooled before initiating packout, or personal injury may result.**

1. Turn off all MBUs and the water heater and allow the equipment to cool. If they were recently used, the steam table, tray pack heater and water heater will contain hot water that will take an hour or more to cool.
2. Remove all food and trash from the kitchen and clean the utensils, pots, pans, griddle, grease filters, grease cup, grease trap, table tops, etc. as necessary.
3. Turn off the refrigerators and mobile warming cabinet and clean them.
4. Turn off the cook center ventilation. The generator, lights and ECU may be left on if desired.
5. Disconnect both ends of the water supply hose and internal drain hose. Drain the supply hose, coil it tightly, and connect its two ends together to minimize the possibility of contamination. Pack the supply hose on the lower shelf of the sink assembly. If it is not needed to drain the steam table, coil the internal drain hose and pack it in the back of the sink assembly.
6. If necessary, drain the steam table after it has cooled. Connect the internal drain hose to the steam table drain connection and the floor drain connection. Remove the stopper and allow the table to drain. Replace the stopper when draining is complete. Disconnect the drain hose, coil it, and pack it in the back of the sink assembly. If necessary, remove the floor drain cover and clean the drain.
7. After it has cooled, drain the water heater. Open both faucet valves, both drain valves (located under the water heater) and collect the water in a suitable container. Close all of the valves when draining is complete. The collected water can be poured into the floor drain.
8. If the tray pack heater must be drained, leave the external drain hose in place – it will be removed later. If not, disconnect the hose and drain it. Coil it tightly, and pack it on the lower shelf of the sink assembly. Install the cap on the external drain connection.

**CONTAINERIZED KITCHEN (CK)  
OPERATION UNDER USUAL CONDITIONS**

0006 00

**Table 2. Loose Item Packout List.**

ITEM	QTY	PACKOUT LOCATION
Fire extinguisher	4	Wall brackets
Ground rod assembly	1	Brackets inside the left door of the mechanical room
Wing jack	8	On top of stair/ladders in the mechanical room
Screw jack	2	Brackets on the left door of the mechanical room
Screw jack extension/base plate	2	Brackets on the floor of the mechanical room
Corner jack	2	Brackets on the left door of the mechanical room
Corner jack extension/base plate	2	Brackets on the left door of the mechanical room
Jack/winch handle	2	Straps on the side of the rifle rack
Tech manuals (CK, MBU)	2	In manual holder
Work table drawer	2	Shelf under the dual oven assembly
Cook pot cradle adapter	4	Top of the griddle, wrapped in the moving blanket
Modern Burner Unit (MBU)	7	In place
Cook pot cradle	2	Under the cook center
Cook pot cradle burner rack	1	Top of the tray pack heater
Cook pot cradle base rack	1	Top of the tray pack heater
Griddle top	1	On the left half of the cook center
Steam table body	1	On the right half of the cook center
Steam table adapter top	1	On top of the steam table body
Beverage dispenser	8	Top shelves of the mobile storage cabinets
Board, food slicing and chopping	2	Inside the mobile warming cabinet
Can, water, plastic, 5-gallon	6	Inside the mechanical room
Can opener, hand	2	In table drawer
Colander, SS, 16-quart	1	Shelf under the right oven
Dipper, 32-ounce	4	Shelf under the right oven
Egg whip	2	In table drawer
Fork, 15-inch	4	In table drawer
Fork, 21-inch	4	In table drawer
Ice cream scoop, size 6	4	In table drawer
Knife, boning, 6-inch	3	In table drawer
Knife, cook's, 10-inch	3	In table drawer
Knife, paring, 3.25-inch	4	In table drawer
Knife, steak, scimitar	3	In table drawer



**CONTAINERIZED KITCHEN (CK)  
OPERATION UNDER USUAL CONDITIONS**

0006 00

Table 2. Loose Item Packout List – Continued

ITEM	QTY	PACKOUT LOCATION
Ladle, 8-ounce, 12-inch handle	4	Shelf under the ovens
Measuring cup, 4-quart	2	Shelf under the right oven
Measuring set, spoons	2	In table drawer
Pan, baking and roasting, w/cover	4	Under the cook center, left side
Pans, baking, full size	10	Inside the mobile warming cabinet
Peeler, potato, hand	3	In table drawer
Pot, cooking, 10-gal, w/cover	3	Nested inside each other, on the lower shelves of the mobile storage cabinets
Pot, cooking, 15-gal, w/cover	3	Lower shelves of the mobile storage cabinets
Skimmer, kitchen	2	In table drawer
Spoon, food service, 15-inch	4	In table drawer
Spoon, food service, 21-inch	4	In table drawer
Spoon, serving, slotted, 15-inch	4	In table drawer
Steam table pan, full size	8	Inside the ovens
Steam table pan, half size	4	Inside the ovens
Tongs, food service, 12-inch	4	In table drawer
Food turner (spatula), 20-inch	4	In table drawer

**Equipment Packout**

**WARNING**

Ensure that all components have completely cooled before initiating packout.

**Cook Center**

Figure 16 illustrates the locations of the items packed on or within the cook center.

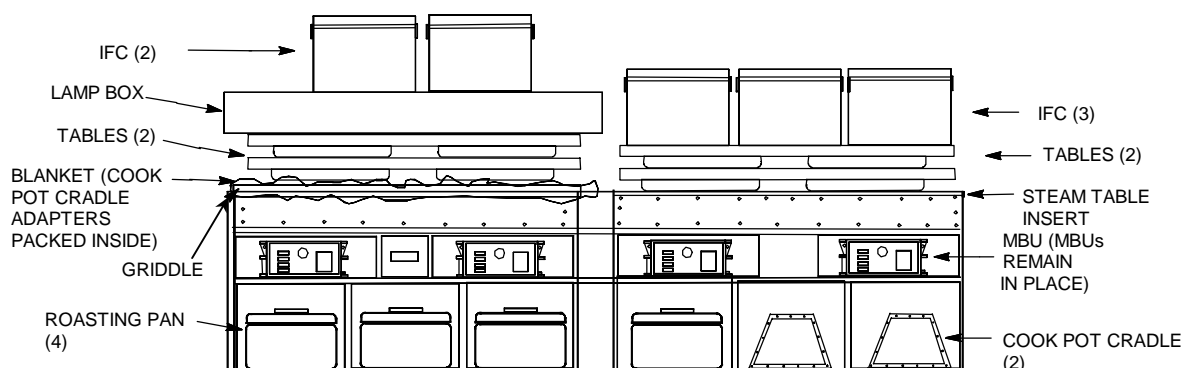

Figure 16. Cook Center Packout.

---

**CONTAINERIZED KITCHEN (CK)  
OPERATION UNDER USUAL CONDITIONS**

0006 00

---

Referring to Figure 16, pack out the cook center as follows:

1. Pack the MBUs, griddle and grease pan in place.
2. Place the moving blanket over the griddle. Place the cook pot cradle adapters on the blanket and fold the blanket over them.
3. Remove the drawer assemblies from the tables and stow them in the oven base. Place two tables, with the legs folded, on the griddle. Place the tables so that their legs are down.
4. Retrieve the light storage box and remove any items stored inside. Unplug and take down the removable light fixtures and place them in the box. Place the griddle splash guards inside the box, on top of the fixtures.

**WARNING**

**The packed light storage box weighs approximately 100 lbs (45.4 kg).  
Three persons must carry the box, lifting with legs not back, to prevent injury.**

5. Place the light storage box on top of the tables. Center the box on the tables.
6. Place two insulated food containers on the light storage box. Center the containers on the box.
7. Place one ratchet tie-down strap over all of the above items. Attach the strap end to the tie-down provision at the mechanical room end of the cook center, and the ratchet end to the tie-down provision at the center of the cook center. Tighten the strap securely.
8. Pack the steam table and adapter top in place.
9. Place two tables, with the drawers removed and the legs folded, on the steam table and adapter top. Stack the tables with their legs down.
10. Place three insulated food containers on the tables. Center the containers on the tables.
11. Place one ratchet tie-down strap over all of the above items. Attach the strap end to the tie-down provision at the center of the cook center, and the ratchet end to the tie-down provision at the right end of the cook center. Tighten the strap securely.
12. Place the lids on each of the four roasting pans. Place one pan in each of the four leftmost compartments in the base assembly.
13. Place one pot cradle in each of the two rightmost compartments.

**Tray Pack Heater**

1. Pack the MBU in place. Disconnect the fuel and power lines, coil them, and pack them in the bottom of the oven assembly. Ensure the fuel line dust plug is in place.
2. Unplug the heater fan power cable from the appliance control box and remove the heater fan assembly from the back of the tray pack heater. If the tray pack heater must be drained, temporarily set the fan assembly aside in a convenient location. Otherwise, pack the assembly inside the tray pack heater.

---

**CONTAINERIZED KITCHEN (CK)  
OPERATION UNDER USUAL CONDITIONS**

---

0006 00

**WARNING**

**DO NOT use one of the water supply hoses to drain the tray pack heater. They are for potable water use and could become contaminated.**

3. If the tray pack heater must be drained, roll it to the area of the personnel access door, open its drain valve, and drain the water into the floor drain. Close the valve when draining is complete. Pack the heater fan assembly inside the tray pack heater.
4. If necessary, disconnect the external drain hose and drain it. Tightly coil the hose and pack it on the lower shelf of the sink assembly.
5. Position the tray pack heater as shown earlier in Figure 15, with its back to the mechanical room wall.
6. Place two ratchet straps over the tray pack heater, running from the loops on the mechanical room wall down to the tie-down provisions in the floor. Tighten the straps securely.
7. Place the base rack inside the burner rack and set both on top of the tray pack heater. Strap them down with two long rubber straps. Hook the straps under the edges of the tray pack heater's base.

**Dual Oven Assembly**

1. Leave the MBUs in place with their fuel and power lines connected.
2. Unplug the 24 VDC power cable from the ceiling raceway. Coil the cable, along with the fuel line and power cable to the tray pack heater, and pack them between the left MBU and the left side of the oven base.
3. Disconnect the fuel line from its outlet at the mechanical room wall and install the dust plugs. Coil the hose and pack it between the right MBU and the right side of the oven base.
4. Unplug the oven fan power cable from the appliance control box. Unplug the box's power cable from the ceiling raceway, coil it, and place the box in one of the drawer assemblies.
5. Pull the oven assembly away from the fabric wall far enough to remove the chimney pipe. Remove the pipe and store it on one of the drawer assemblies.
6. Position the oven assembly as shown earlier in Figure 15, with its back toward the cook center, and strap it down with two ratchet straps from side to side. Run the straps under the oven fan assembly.

**Refrigerators**

1. Place four insulated food transporters in each refrigerator, one on each shelf.
2. Strap the containers to the shelves using one short rubber strap over each container, placed from back to front.
3. Unplug the refrigerators and temporarily move them to the serving wing while completing packout and closure of the food preparation wing.

---

**CONTAINERIZED KITCHEN (CK)  
OPERATION UNDER USUAL CONDITIONS**

0006 00

---

**Mobile Warming Cabinet**

1. Unplug the power cord, coil it, and hang it from the holder on the back of the unit.
2. Place all the baking pans except one on the bottom slides.
3. Place the cutting boards on the baking pans.
4. Install another set of slides just above the baking pans.
5. Place the remaining baking pan on the slides.
6. Place three insulated food containers on this pan.
7. Install another set of slides just above the top insulated food container.
8. Place all remaining loose slides on top of the top insulated food container.
9. Place two short rubber straps crossed over the top of the loose slides and containers. Hook the straps to the front rack hangers. Stretch the straps across and up and hook them to the rear rack hangers, ensuring that the strap hooks are completely hooked into holes in the rack hangers.
10. Close and latch the warming cabinet doors.
11. Position the warming cabinet as shown earlier in Figure 15, with its back to the side of the dual oven assembly, and strap it down with two ratchet straps run from back to front.

**Mobile Storage Cabinets**

1. Place four beverage dispensers on the top shelf of each storage cabinet. Strap them in place with one short rubber strap placed across the front of the beverage dispensers.
2. Nest the 10-gallon pots inside each other. Place them and the 15-gallon pots on the bottom shelves of the storage cabinets. Place the pot lids on top of the pots. Strap them in place with one short rubber strap placed across the front of the pots.
3. Position the storage cabinets side by side as shown earlier in Figure 15, with their fronts facing the cook center, and strap each down with one ratchet strap run from side to side. Tighten the straps securely.

**Hand Sink Assembly**

1. Tightly coil the internal drain hose and pack it in the back of the sink assembly.
2. Tightly coil the water supply hose and connect its ends together to prevent contamination. Tightly coil the external drain hose. Pack both hoses on the lower shelf of the sink assembly.
3. Locate the sink assembly as shown earlier in Figure 15, with its back to the side of the mobile warming cabinet, and strap it down with one ratchet strap run from side to side. Tighten the strap securely.

---

**CONTAINERIZED KITCHEN (CK)  
OPERATION UNDER USUAL CONDITIONS**

---

0006 00

**Food Preparation Wing Closure**

1. Close and secure the windows in the food preparation wing.
2. Retrieve any ratchet straps and rubber straps still hanging in the food preparation wing and place them in a convenient location in the serving wing.
3. Retrieve the empty arch component storage bags.

**WARNING**

**A storage bag filled with shelter arch components weighs approximately 130 lbs (59 kg). Three persons must carry the bag, lifting with legs, not back, to prevent injury.**

4. Remove the adjustable spacer. Starting in the middle of the wing, remove the arch spacers and arch frame assemblies (it may be necessary for personnel to push up on the fabric while removing the assemblies). Disassemble the components and place them in one of the storage bags. Temporarily move the bag to the serving wing so it is out of the way.
5. If still running, turn off the ECU and then shut down the generator from the generator control panel.
6. Remove the locking pins attaching the three wing jacks to the wing, and remove the jacks. It may be necessary to retrieve a winch handle and crank the wing up slightly to take the weight off the pins before they can be removed.
7. If installed, remove the platform rail, platform, and stair/ladder at the personnel door and temporarily set them out of the way (the platform will interfere with the winch handle).

**WARNING**

**When raising or lowering the wings, one member of the crew must act as a spotter to ensure that all personnel stay clear.**

8. If not already done, retrieve a jack/winch handle from its storage location on the side of the rifle rack.
9. Winch up the wing using the left winch. When the wing is approximately halfway up, stop winching. Push in on the fabric at each end of the wing so it will properly fold up as the wing is closed.
10. Continue winching up the wing. When it is nearly closed, climb onto the container and attach the orange safety strap. After the strap is attached, unlock and rotate the four cam-locks on the side of the wing 90° so their handles are pointing straight outward.
11. Continue winching up the wing until it is almost closed and the winch becomes hard to turn. The spotter can advise the person operating the winch when the wing is almost closed.
12. Partially close the four cam-locks by rotating their handles approximately 45° toward their locked position. Crank the wing closed a few more turns, then completely engage and lock the cam-locks.

---

**CONTAINERIZED KITCHEN (CK)  
OPERATION UNDER USUAL CONDITIONS**

---

0006 00

**Refrigerator Tie-Down**

1. Place the long ends of three ratchet straps in the tie-down provisions for the first refrigerator.
2. Referring to Figure 15, position the right-hand hinged refrigerator with its front facing outboard toward the closed food preparation wing. Place the three straps over the top of the refrigerator, two from side to side and one from front to back. Move the refrigerator into its final position. Attach the ratchet end of each strap to the appropriate tie-down provision in the floor and tighten the straps securely.
3. Place the long ends of three ratchet straps in the tie-down provisions for the second refrigerator.
4. Position the second refrigerator with its back facing the back of the first refrigerator. Place the three straps over the top of the refrigerator, two from side to side and one from front to back. Move the refrigerator into its final position. Attach the ratchet end of each strap to the appropriate tie-down provision in the floor and tighten the straps securely.

**Serving Side Shelter Closure****WARNING**

**A storage bag filled with shelter arch components weighs approximately 130 lbs (59 kg). Three persons must carry the bag, lifting with legs, not back, to prevent injury.**

1. Place the bag of shelter arch components from the food preparation wing against the refrigerator, angling the bag so one end is against the ceiling and the other against the side of the cook center.
2. Close and secure all doors and windows in the wing except the door nearest the personnel access door. Fold the bottom of the door inward and push it under the door so it will not be caught when the wing is closed.
3. Retrieve the remaining arch component storage bag.
4. Remove the curved spacers and place them in the storage bag. Starting in the middle of the wing, remove the arch spacers and arch frame assemblies. Disassemble the frame assemblies and place the components in the storage bag. Close the bag and place it bag beside the other one, against the refrigerator.
5. If installed, remove the stair/ladders.
6. Secure the remaining serving door. Fold the bottom of the door inward and push it under the door so it will not be caught when the wing is closed.
7. Remove the locking pins attaching the three wing jacks to the wing, and remove the jacks. It may be necessary to crank the wing up slightly to take the weight off the pins before they can be removed.

---

**CONTAINERIZED KITCHEN (CK)  
OPERATION UNDER USUAL CONDITIONS**

---

0006 00

**WARNING**

**When raising or lowering the wings, one member of the crew must act as a spotter to ensure that all personnel stay clear.**

8. Winch up the wing using the right winch. When the wing is approximately halfway up, stop winching. Push in on the fabric at each end of the wing so it will properly fold up as the wing is closed.
9. Continue winching up the wing. When it is nearly closed, climb onto the container and attach the orange safety strap. After the strap is attached, unlock and rotate the four cam-locks on the side of the wing 90° so their handles are pointing straight outward.
10. Continue winching up the wing until it is almost closed and the winch becomes hard to turn. The spotter can advise the person operating the winch when the wing is almost closed.
11. Partially engage the four cam-locks by rotating their handles approximately 45° toward their locked position. Crank the wing closed a few more turns, then completely engage and lock the cam-locks.
12. Return the jack/winch handle to its storage location on the side of the rifle rack. Strap it in place with its handle end up.
13. Pack the three pairs of stair railings upside down just inside the personnel door. Strap the railings in place on both sides of the door using two short rubber straps.
14. On the Main Control Panel, turn the INTERIOR LIGHTING and EMERGENCY LIGHT switches OFF.
15. Close and latch the personnel door.

**Jack Removal**

If they were used, remove the corner jacks and screw jacks as follows.

1. Lower the corner jacks until the end of the container is resting on the ground. Remove the jacks.
2. Install the corner jacks at the opposite end of the container. Raise the end of the container just until the weight is off of the screw jacks. Remove the screw jacks.
3. Lower the corner jacks until the end of the container is resting on the ground. Remove the jacks.

**Mechanical Room Packout**

**WARNING**

**To prevent personal injury, notify personnel inside the CK before removing the platform from in front of the personnel door.**

1. If the CK is mounted on a trailer, install the platform at the mechanical room doors. Hook the platform into the bracket on the container and support the other side using two wing jacks.

---

**CONTAINERIZED KITCHEN (CK)  
OPERATION UNDER USUAL CONDITIONS**

---

**0006 00**

2. Unbuckle the awning from both doors and lay it up out of the way.
3. Remove the awning support bar from the brackets on the doors. Slip the straps from the generator, air conditioner, and exhaust fan ducts from the awning rod. Leave the loops in the straps, and the ducts attached to the units.
4. Store the awning support bar on the floor just inside the mechanical room.
5. Stuff the generator and air conditioner ducts into the openings of the units so that they are not in the way. Drape the hood exhaust duct behind the generator discharge hood.
6. Remove the two door braces and store them on the floor underneath the air conditioners.

**WARNING**

**Ensure that the generator exhaust pipe has completely cooled before attempting to disassemble the elbow pipe.**

7. Remove the generator exhaust elbow pipe by loosening the clamp and slipping the elbow through the awning from above. Store it at the right end of the generator. Leave the clamp attached to the exhaust pipe end at the ceiling of the mechanical room.
8. Unscrew the awning from the door frame. Fold it and pack it on top of the generator.
9. Retrieve the ground rod assembly, clean it, and store it in its brackets next to the Power Entrance Panel.
10. If they were used, place the screw jack extension/base plates at the left end of the generator. Strap them down with two short rubber straps.
11. Disconnect the MBU fuel line at the connection below the Power Entrance Panel. Remove the fuel can adapter from the can, place it in its storage bag, and pack it on the floor to the left of the generator. Put the cap on the fuel can and remove the can from the mechanical room. Stow the strap in any convenient place in the mechanical room.
12. Disconnect the generator's auxiliary fuel line at the other fuel can. Remove the fuel can adapter from the can, place it in its storage bag, and pack it on the floor to the left of the generator. Put the cap on the fuel can.
13. Coil the generator's auxiliary fuel line and stow it on the floor to the left of the generator.
14. Disconnect the wing jacks from the platform. Remove the platform and slide it, with the edge containing the jack brackets up, between the screw jack extension/base plates and the front of the generator. Pack the platform railing next to the platform.
15. Place the long portions of two ratchet straps into the two loops located at the base of the generator. Temporarily place the loose ends of the straps on top of the generator.
16. Place the three stair/ladders on their sides with their tops to the left.
17. Place the 6 water cans, on their sides, between the stair/ladder treads.
18. Strap the stair/ladders in place by bringing the two ratchet straps over them and securing them to the rings on the floor. Tighten the straps securely.



---

**CONTAINERIZED KITCHEN (CK)  
OPERATION UNDER USUAL CONDITIONS**

---

**0006 00**

19. Place the wing jacks, with their base plates to the left, on top of the stair/ladders. Slide the tops of the jacks under the air conditioner and secure the jacks to the stair/ladders using two short rubber straps.
20. If the corner jacks and screw jacks were used, separate the jack bodies from the extension/base plates. Store the corner jacks bodies, their extension/base plates, and the screw jack bodies in their storage brackets on the left door. Ensure that the jacks and base plates are properly secured to the brackets.
21. Stow the screw jack extension/base plates on the floor to the left of the generator and strap them down with a short rubber strap.
22. Ensure that the ends of the two air conditioner condensation drain lines are stowed inside the mechanical room so they will not be damaged when the doors are closed.
23. Closing the left door first, close and latch the mechanical room doors.
24. Place all three fuel cans in a Food Service Section vehicle.

END OF WORK PACKAGE

---

**CONTAINERIZED KITCHEN (CK)  
OPERATION UNDER UNUSUAL CONDITIONS**

---

0007 00

**INITIAL SETUP:**

Kitchen set up and operating

**Maintenance Level**

Operator/Crew

**Personnel Required**

Four (plus one supervisor)

**GENERAL**

This work package provides instructions for operating the CK under unusual conditions. These include adverse weather; nuclear, biological, and chemical attack; and emergency blackout conditions.

**ADVERSE WEATHER CONDITIONS**

**Operation in Rain and/or Mud**

1. Provide an adequate drainage ditch to prevent standing water around the CK.
2. Frequently check the jacks for sinking. Level the container as required by adjusting the corner jacks, screw jacks, or trailer jacks, as applicable. It may also be necessary to adjust the wing jacks to maintain level floors.
3. Close and secure all shelter doors except the mechanical room doors. These cannot be shut when the CK is set up for operation.
4. Check door seals for proper placement and compression.
5. From the inside, inspect the CK for leaks.

**Operation in Hot Weather**

**WARNING**

**High heat generated during CK operation may be a health hazard. The section supervisor must constantly monitor personnel and follow local Standard Operating Procedures.**

1. Operate the MBUs at the lowest setting that will ensure proper cooking.
2. Minimize the use of electrical appliances. This makes more power available for the air conditioners.
3. For better ventilation, open the windows and doors. The windows can be rolled up and secured with the straps provided. The serving wing doors can be rolled up from inside the kitchen and wedged between the shelter roof and the arched spacer above each doorway.
4. The ECU is designed to provide some degree of comfort to cooks in the food preparation area. It is not designed to cool the entire CK.

---

**CONTAINERIZED KITCHEN (CK)  
OPERATION UNDER UNUSUAL CONDITIONS**

---

**0007 00**

**Operation in Snow, Ice, or Extreme Cold**

**WARNING**

**In extreme cold, do not touch metal parts with bare hands. Severe skin damage may result.**

**NOTE**

**Fluorescent lights may be slow to light at very low temperatures.**

1. If freezing conditions exist or are possible while the CK is set up and operating, the external water supply and drain should not be used.

**CAUTION**

**At temperatures below freezing, the water supply and drain hoses will be stiff. Do not attempt to straighten or coil a frozen hose or equipment damage may result. Place the hoses inside the heated shelter until they have warmed enough to be coiled.**

2. If connected, disconnect and drain the water supply hose and the external drain hose. Coil each hose and store them in the hand sink assembly.
3. To use the hand sink, connect one of the 25-ft water supply hoses to the supply connection on the back of the sink assembly. Position a filled 5-gallon potable water can beside the sink assembly and insert the other end of the hose into the can.

**NOTE**

**The water heater holds about 6 gallons. If it is not already full from prior use of the sink, at least two filled water cans will be needed to start.**

4. Collect drainage from the hand sink in a suitable container placed underneath the external drain hose connection.
5. Keep all doors and windows closed.
6. Lubricate door weather seals with silicone spray (WP 0051 00, Table 1, Item 4) to prevent sticking.
7. Adjust the air curtain dampers along the front edge of the cook center hood if the air is uncomfortably cold.
8. Run the cook center fans at the lowest practical level to avoid removing warm inside air.
9. Do not allow ice and snow to build up on the wing roofs. As necessary, remove any accumulation with a soft bristle brush, broom, or equivalent.
10. Remove ice and snow from the wing roofs before folding them.

---

**CONTAINERIZED KITCHEN (CK)  
OPERATION UNDER UNUSUAL CONDITIONS**

---

0007 00

**Draining the Water System**

If freezing conditions are possible while the CK is packed for transport, or the kitchen is to be left set up but unheated during possible freezing conditions, drain the water system to prevent damage.

1. Turn off the water pump and water heater at the appliance control box.
2. Disconnect and drain the water supply hose. If packing the kitchen for transport, coil the hose, connect its two ends together, and store it on the lower shelf in the front of the sink assembly.
3. Open the hot and cold water faucets to release the pressure in the system. Leave the faucets open.
4. Drain the cold water line into a pan, bucket, or other container by opening the drain valve at the back of the sink assembly.
5. Drain the water heater into a suitable container by opening the water heater drain valve.
6. With both drain valves open, turn on the water pump for several seconds to purge the pump of water. Turn off the pump when there is no sign of water coming from the drains.
7. If necessary, slightly tilt the sink assembly to drain any water remaining in the sink bowl and drain pipe.
8. Disconnect the interior drain hose from the sink assembly and drain it into the floor drain. If packing the kitchen for transport, disconnect the hose from the fitting on the floor drain, coil it, and store it on the shelf in the back of the sink assembly.
9. Disconnect and drain the external drain hose. If packing the kitchen for transport, coil the hose tightly and store it in the lower shelf in the front of the sink assembly.
10. Ensure that the hot and cold water lines and the water heater are completely drained, then close the drains and faucets.

**FORDING AND SWIMMING**

In the packed-out configuration, the CK is not watertight. It should never be submerged in any depth of water or equipment damage may result. When mounted on a trailer, hard-bottom water crossings no deeper than approximately 2 feet can be forded. When in doubt, refer to Unit Standard Operating Procedures.

**INTERIM NUCLEAR, BIOLOGICAL, AND CHEMICAL (NBC) DECONTAMINATION PROCEDURES**

When an NBC attack is expected, and time allows, the kitchen should be packed for transport per WP 0006 00 until the threat of attack is over. If an NBC attack occurs, the unit must be decontaminated before use in accordance with FM 3-5.

**JAMMING AND ELECTRONIC COUNTERMEASURES**

The CK is not affected by jamming or electronic countermeasures.

---

**CONTAINERIZED KITCHEN (CK)  
OPERATION UNDER UNUSUAL CONDITIONS**

---

**0007 00**

**EMERGENCY PROCEDURES**

**Operation During Blackout Conditions**

Meal preparation and serving can be conducted during blackout conditions. Kitchen doors should be opened only as necessary, and should be closed as soon as possible.

1. Ensure that all door and window flaps are closed and sealed.
2. With the LIGHTING MODE switch on the Main Control Panel in NORMAL, turn on the interior lights and check the perimeter of the kitchen from at least 25 feet away to ensure no light is visible.
3. Place the LIGHTING MODE switch in the BLACKOUT position.

END OF WORK PACKAGE

**CHAPTER 3**  
**TROUBLESHOOTING PROCEDURES**

THIS PAGE INTENTIONALLY LEFT BLANK

---

**CONTAINERIZED KITCHEN (CK)  
INTRODUCTION**

**0008 00**

---

**MALFUNCTION/SYMPTOM INDEX**

The malfunction/symptom index (WP 0009 00) is a quick reference for finding troubleshooting procedures. Associated with each symptom name is a work package sequence number representing the starting point in a troubleshooting sequence. As the troubleshooting activity progresses through to the conclusion of a sequence, a reference is made to the next logical troubleshooting sequence by work package sequence number or by referring to the malfunction/symptom index to locate the next failure symptom work package. This type of activity continues until successful fault isolation is achieved.

**TROUBLESHOOTING PROCEDURES**

The troubleshooting work packages contain tables listing the malfunctions, checks or inspections, and corrective actions required to return the equipment to normal operation. Perform the steps in the order they appear in the tables.

Each work package is headed by an initial setup. This setup outlines what is needed as well as the conditions that must be met before starting the task. **DO NOT START A TASK UNTIL:**

- You understand the task.
- You understand what you are to do.
- You understand what is needed to do the work.
- You have the things you need.

This manual cannot list all malfunctions that may occur, or all tests, inspections and corrective actions. If a malfunction is not listed or is not corrected by listed corrective actions, notify unit maintenance.

**GENERAL INFORMATION**

When troubleshooting the electrical system with power connected, place all switches and circuit breakers in the OFF position.

If any circuit breaker trips after it has been reset, notify unit maintenance.



THIS PAGE INTENTIONALLY LEFT BLANK

**CONTAINERIZED KITCHEN (CK)  
MALFUNCTION/SYMPTOM INDEX**

0009 00

**MALFUNCTION/SYMPTOM**

**TROUBLESHOOTING PROCEDURE**

**Electrical System**

No power to kitchen – external source .....WP 0010 00  
 No power to kitchen – generator source.....WP 0010 00  
 Generator will not crank .....WP 0010 00  
 Generator cranks but does not start.....WP 0010 00  
 Interior lights do not work .....WP 0010 00  
 No power at one or more receptacles .....WP 0010 00

**Modern Burner Unit (MBU)**

MBU does not power up.....WP 0011 00  
 MBU powers on but does not start .....WP 0011 00  
 MBU shuts down during operation .....WP 0011 00  
 MBU fails to fuel.....WP 0011 00

**Environmental Control Unit**

Air conditioners running but are not cooling .....WP 0012 00  
 Heater does not start.....WP 0012 00

**Hand Sink Assembly**

No hot or cold water .....WP 0013 00  
 Low water pressure.....WP 0013 00  
 No hot water .....WP 0013 00  
 Water is still cold after 30 minutes.....WP 0013 00  
 Water is too hot.....WP 0013 00  
 Sink drains slowly or does not drain.....WP 0013 00  
 No soap from dispenser .....WP 0013 00

**Kitchen Appliances**

Refrigerator does not operate .....WP 0014 00  
 Refrigerator operates but does not cool .....WP 0014 00  
 Mobile warming cabinet does not heat .....WP 0014 00  
 Tray pack heater fan does not work .....WP 0014 00  
 Oven fan does not work .....WP 0014 00

THIS PAGE INTENTIONALLY LEFT BLANK

**CONTAINERIZED KITCHEN (CK)  
TROUBLESHOOTING PROCEDURES (ELECTRICAL SYSTEM)**

**0010 00**

**THIS WORK PACKAGE COVERS:**

Electrical System

**INITIAL SETUP:**

Kitchen set up

**Maintenance Level**

Operator/Crew

**ELECTRICAL SYSTEM MALFUNCTIONS**

**Table 1. Troubleshooting Procedures (Electrical System)**

<b>Malfunction</b>	<b>Test or Inspection</b>	<b>Corrective Action</b>
No power to kitchen – external source	EXTERNAL POWER AVAILABLE indicator (Main Control Panel) is not lit	Ensure that the external power cable is properly connected (Power Entrance Panel)  Ensure that the power cable is connected to the source and the source is energized  Ensure that the external power control circuit breaker (Power Entrance Panel) is closed (pushed in)  Notify unit maintenance
	EXTERNAL POWER AVAILABLE indicator is lit, EXTERNAL POWER indicator is not lit	Press the EXTERNAL POWER pushbutton (Main Control Panel)  Notify unit maintenance
	EXTERNAL POWER AVAILABLE indicator is lit and EXTERNAL POWER indicator is lit	Check/reset the input power circuit breaker (#1 on Power Distribution Panel)  Notify unit maintenance
No power to kitchen – generator source	Generator is running, GENERATOR POWER AVAILABLE indicator is not lit	Check/close the AC CIRCUIT INTERRUPTER switch (generator control panel)

**CONTAINERIZED KITCHEN (CK)  
TROUBLESHOOTING PROCEDURES (ELECTRICAL SYSTEM)**

**0010 00**

**Table 1. Troubleshooting Procedures (Electrical System) – Continued**

Malfunction	Test or Inspection	Corrective Action
Generator will not crank	GENERATOR POWER AVAILABLE indicator is lit, GENERATOR POWER indicator is not lit.	Ensure that the generator power control circuit breaker (Power Entrance Panel) is shut (pushed in)  Notify unit maintenance  Press the GENERATOR POWER pushbutton (Main Control Panel)
	GENERATOR POWER AVAILABLE indicator is lit, GENERATOR POWER indicator is lit	Notify unit maintenance  Check/reset the input power circuit breaker (#1 on Power Distribution Panel).  Notify unit maintenance
	Check that the E-Stop (Main Control Panel) is reset (pulled out)	Reset E-Stop
	Check that DC control power circuit breaker CB1 (behind generator control panel) is reset (pushed in)	Reset circuit breaker
	Check that the E-Stop circuit breaker (Power Entrance Panel) is reset (pushed in)	Reset circuit breaker
	Check that the generator DEAD CRANK switch is in NORMAL (behind generator access door accessible from inside the mechanical room)	Place switch in NORMAL
Generator cranks but does not start	Check generator battery connections (inside access doors on both sides of generator)	If loose or corroded, notify unit maintenance
	Check that the generator DEAD CRANK switch is in NORMAL (behind generator access door accessible from inside the mechanical room)	Place switch in NORMAL

**CONTAINERIZED KITCHEN (CK)  
TROUBLESHOOTING PROCEDURES (ELECTRICAL SYSTEM)**

**0010 00**

**Table 1. Troubleshooting Procedures (Electrical System) - Continued**

Malfunction	Test or Inspection	Corrective Action
Interior lights do not work	Check generator fuel level	Refill fuel tank
	Check for dirty fuel filter/water separator	Service fuel filter/water separator (Refer to TM 9-6115-642-10)
Interior lights do not work	Check air cleaner restriction indicator for indication of a clogged air cleaner (inside access door by cook center)	Service air cleaner assembly (Refer to TM 9-6115-642-10)
	Ambient temperature below 40°F	Turn master switch (generator control panel) to PREHEAT for no more than 30 seconds before cranking engine. Refer to TM 9-6115-642-10 Notify unit maintenance
Interior lights do not work	No other electrical components operate	See "No Power to Kitchen"
	All other electrical components operate	Check/reset lighting circuit breaker (#19 on Power Distribution Panel) Notify unit maintenance
No power at one or more receptacles	No other electrical components operate	See "No Power to Kitchen"
	All other electrical components operate properly	Check/reset ground fault interrupter (on receptacle next to spice rack) Notify unit maintenance

END OF WORK PACKAGE

THIS PAGE INTENTIONALLY LEFT BLANK

**CONTAINERIZED KITCHEN (CK)  
TROUBLESHOOTING PROCEDURES (MODERN BURNER UNIT)**

0011 00

**THIS WORK PACKAGE COVERS:**

Modern Burner Unit (MBU)

**INITIAL SETUP:**

CK set up

**Maintenance Level**

Operator/Crew

**MODERN BURNER UNIT (MBU) MALFUNCTIONS**

**Table 1. Troubleshooting Procedures (MBU)**

<b>Malfunction</b>	<b>Test or Inspection</b>	<b>Corrective Action</b>
MBU does not power up	No power to any MBUs	Ensure MBU Power switch (next to spice rack) is ON Ensure MBU converter is ON (front wall inside mechanical room) Ensure MBU converter is plugged in (mechanical room) Ensure 24 VDC is properly connected from the converter to the MBUs Notify unit maintenance
	Power available to all but one MBU	Ensure power cable to affected MBU is properly connected Swap MBU with another unit to determine if the problem is in the MBU or power cable Refer to TM 10-7310-281-13&P for additional troubleshooting guidance for the MBU Notify unit maintenance
MBU powers on but does not start	Check low fuel light on MBU	Refuel MBU



**CONTAINERIZED KITCHEN (CK)  
TROUBLESHOOTING PROCEDURES (MODERN BURNER UNIT)**

**0011 00**

**Table 1. Troubleshooting Procedures (Modern Burner Unit) – Continued**

Malfunction	Test or Inspection	Corrective Action
<p>MBU shuts down during operation</p>	<p>MBU is in cook center</p> <p>MBU is in oven assembly or tray pack heater</p> <p>No power at the unit</p> <p>MBU power is on</p>	<p>Start right-side MBU first</p> <p>Check/connect fuel connection at the base of the mechanical room wall</p> <p>Refer to TM 10-7310-281-13&amp;P for additional troubleshooting guidance for the MBU</p> <p>Notify unit maintenance</p> <p>See “MBU does not start”</p> <p>Check fuel level light on MBU. Refuel if necessary</p> <p>Refer to TM 10-7310-281-13&amp;P for additional troubleshooting guidance for the MBU</p> <p>Notify unit maintenance</p>
<p>MBU fails to fuel</p>	<p>No power to the unit</p> <p>MBU has power but air compressor cannot be heard</p> <p>MBU power is on and air compressor is running</p>	<p>See “MBU does not start”</p> <p>Refer to TM 10-7310-281-13&amp;P for additional troubleshooting guidance for the MBU</p> <p>Notify unit maintenance</p> <p>NOTE: Refueling can take up to 4 minutes for a single MBU, and even longer when more than one is refueling at a time.</p> <p>Ensure that the fuel line to the fuel can is connected, can contains fuel, and valve on fuel can adapter is open</p> <p>Ensure that all hoses are free of leaks and fittings are tight</p> <p>Refer to TM 10-7310-281-13&amp;P for additional troubleshooting guidance for the MBU</p> <p>Notify unit maintenance</p>

END OF WORK PACKAGE

---

**CONTAINERIZED KITCHEN (CK)  
TROUBLESHOOTING PROCEDURES (ENVIRONMENTAL CONTROL UNIT)**

**0012 00**

---

**THIS WORK PACKAGE COVERS:**

Environmental Control Unit (ECU)

**INITIAL SETUP:**

CK set up

**Maintenance Level**

Operator/Crew

---

**ENVIRONMENTAL CONTROL SYSTEM MALFUNCTIONS**

**Table 1. Troubleshooting Procedures (ECU)**

<b>Malfunction</b>	<b>Test or Inspection</b>	<b>Corrective Action</b>
Air conditioners running but are not cooling	Hot air from air ducts	<p>Check ECU control switch position</p> <p>Check/reset ECU circuit breakers (Power Distribution Panel). NOTE: If breakers are cycled, there is a 4-minute built in time delay before cooling will start</p> <p>NOTE: When humidity is high, A/C will work to reduce it, with only a slight reduction in temperature</p> <p>Notify unit maintenance</p>
Heater does not start		<p>Check/reset circuit breaker (#8 on Power Distribution Panel)</p> <p>Notify unit maintenance</p>

END OF WORK PACKAGE

THIS PAGE INTENTIONALLY LEFT BLANK

**CONTAINERIZED KITCHEN (CK)  
TROUBLESHOOTING PROCEDURES (HAND SINK ASSEMBLY)**

**0013 00**

**THIS WORK PACKAGE COVERS:**

Hand Sink Assembly

**INITIAL SETUP:**

CK set up

**Maintenance Level**

Operator/Crew

**HAND SINK ASSEMBLY MALFUNCTIONS**

**Table 1. Troubleshooting Procedures (Hand Sink Assembly)**

<b>Malfunction</b>	<b>Test or Inspection</b>	<b>Corrective Action</b>
No hot or cold water	Water pump running	Immediately turn water heater OFF (appliance control box)
	Check hoses for kinks, obstructions, leaks, missing washers Supply valve from tank trailer open	Remove kinks, tighten loose or leaking fittings, repair/replace damaged hose Check/open valve
Low water pressure	Pump will not run	Notify unit maintenance Immediately turn water heater OFF (appliance control box) Check/plug in pump power cord Verify pump switch is ON (appliance control box) Verify appliance control box is plugged in Check/reset pump circuit breaker (appliance control box) Check/reset appliance control box circuit breaker (#24 on Power Distribution Panel) Notify unit maintenance
	Check hoses for kinks, obstructions, leaks, missing washers Supply valve from tank trailer open	Remove kinks, tighten loose or leaking fittings, replace damaged hose Check/open valve

**CONTAINERIZED KITCHEN (CK)  
TROUBLESHOOTING PROCEDURES (HAND SINK ASSEMBLY)**

**0013 00**

**Table 1. Troubleshooting procedures (Hand Sink Assembly) - Continued**

Malfunction	Test or Inspection	Corrective Action
No hot water	Water heater plugged in  Water heater switch ON (appliance control box)  Appliance control box plugged in  Water heater circuit breaker open (appliance control box)  Appliance control box receptacle circuit breaker closed	Notify unit maintenance  Check/plug in water heater (appliance control box)  Turn water heater switch ON  Plug in appliance control box  Check/reset water heater circuit breaker (appliance control box)  Check/reset appliance control box circuit breaker (#24 on Power Distribution Panel)  Open hot water faucet to purge air and wait 30 minutes for water in tank to heat  Notify unit maintenance
Water is still cold after 30 minutes	Water heater switch ON (appliance control box)  Water heater circuit breaker open (appliance control box)	Turn water heater switch ON  Check/reset water heater circuit breaker (appliance control box)  Notify unit maintenance
Water is too hot		Notify unit maintenance to adjust thermostat
Sink drains slowly or does not drain	Check sink trap for clogging. Check drain hoses for kinks, obstructions	Unclog sink trap. Remove kinks or obstructions in drain hoses
No soap from dispenser	Check soap level in dispenser	Refill soap dispenser

END OF WORK PACKAGE

**CONTAINERIZED KITCHEN (CK)  
TROUBLESHOOTING PROCEDURES (KITCHEN APPLIANCES)**

**0014 00**

**THIS WORK PACKAGE COVERS**

Kitchen Appliances

**INITIAL SETUP:**

CK set up

**Maintenance Level**

Operator/Crew

**KITCHEN APPLIANCE MALFUNCTIONS**

**Table 1. Troubleshooting Procedures (Kitchen Appliances)**

<b>Malfunction</b>	<b>Test or Inspection</b>	<b>Corrective Action</b>
Refrigerator does not operate	Power cord plugged in	Plug in power cord
	Refrigerator receptacle circuit breaker tripped	Check/reset circuit breaker (#7 or #9 on Power Distribution Panel)
	Thermostat turned off	Turn on/adjust thermostat Notify unit maintenance
Refrigerator operates but does not cool	Thermostat setting too high	Adjust thermostat to colder setting
	Obstructed air flow at base of unit	Clear airflow obstructions
	Refrigerator door not sealed	Reclose door
	Inspect door gasket for tears, cuts, or other damage	Notify unit maintenance
Mobile warming cabinet does not heat	Power cord plugged in	Plug in power cord
	Warming cabinet receptacle circuit breaker tripped	Check/reset circuit breaker (#16 on Power Distribution Panel)
	Check temperature setting (at bottom front of cabinet)	Adjust temperature setting (at bottom front of cabinet)
		Notify unit maintenance

**CONTAINERIZED KITCHEN (CK)  
TROUBLESHOOTING PROCEDURES (KITCHEN APPLIANCES)**

**0014 00**

**Table 1. Troubleshooting Procedures (Kitchen Appliances) - Continued**

<b>Malfunction</b>	<b>Test or Inspection</b>	<b>Corrective Action</b>
Tray pack heater fan does not work	Heater fan power cord plugged in	Check/plug in power cord (appliance control box)
	Heater fan switch ON (appliance control box)	Turn heater fan switch ON
	Heater fan circuit breaker open (appliance control box)	Check/close circuit breaker
	Appliance control box plugged in	Plug in appliance control box
	Appliance control box receptacle circuit breaker closed	Check/close appliance control box circuit breaker (#24 on Power Distribution Panel)
	Plug heater fan power cord into a different receptacle on appliance control box	Notify unit maintenance
Oven fan does not work	Oven fan power cord plugged in	Check/plug in power cord (appliance control box)
	Oven fan switch ON (appliance control box)	Turn oven fan switch ON
	Oven fan circuit breaker open (appliance control box)	Check/close circuit breaker
	Appliance control box plugged in	Plug in appliance control box
	Appliance control box receptacle circuit breaker closed	Check/close appliance control box circuit breaker (#24 on Power Distribution Panel)
	Plug oven fan power cord into a different receptacle on appliance control box	Notify unit maintenance

END OF WORK PACKAGE

**CHAPTER 4**  
**OPERATOR/UNIT MAINTENANCE PROCEDURES**



THIS PAGE INTENTIONALLY LEFT BLANK

---

**CONTAINERIZED KITCHEN (CK)  
SERVICE UPON RECEIPT**

**0015 00**

---

**THIS WORK PACKAGE COVERS:**

Unpacking, inspection

**INITIAL SETUP:**

CK packed out

**Maintenance Level**

Operator/Crew

---

**UNPACKING**

The CK is shipped with all components and equipment packed inside the ISO container. To unpack upon receipt, set up the kitchen as described in WP 0006 00.

**INSPECTION**

Inspect the equipment for damage incurred during shipment. Report any damage on SF 361, Transportation Discrepancy Report.

Check the equipment against the Components of End Item and Basic Issue Items lists (WP 0049 00) to verify that the CK is complete. Report any discrepancies in accordance with DA PAM 738-750.

Check to see that the generator's control panel door and right side door have been removed (they should be, but may not be if the generator has been replaced). The doors may be in position, but their hinges should be unbolted. The control panel door is accessible through the food preparation area wall, and the right side door is accessible through the door next to the cook center. Notify your supervisor if either door has not been unbolted – the generator must be removed from the CK to unbolt them.

Perform Service Upon Receipt for the generator in accordance with TM 9-6115-642-24. Perform Service Upon Receipt for the MBUs in accordance with TM 10-7310-281-13&P.

END OF WORK PACKAGE

THIS PAGE INTENTIONALLY LEFT BLANK

---

**CONTAINERIZED KITCHEN (CK)  
PREVENTIVE MAINTENANCE CHECKS AND SERVICES (PMCS)**

---

0016 00

**THIS WORK PACKAGE COVERS:**

Introduction, Preventive Maintenance Checks and Services (PMCS) Procedures

**INITIAL SETUP:**

CK set up

**Maintenance Level**

Operator/Crew

---

**INTRODUCTION**

Preventive Maintenance Checks and Services (PMCS) are performed to keep the CK and its associated equipment in good operating condition. The checks are used to find, correct, or report problems. Operators and Unit maintenance personnel are to perform the PMCS tasks as shown in the PMCS tables. PMCS are done every day the CK is operated, using the appropriate PMCS table.

Perform all checks and services keeping in mind the following guidelines:

Before you begin using the CK, do **Before Operation PMCS**

While the CK is in use, do **During Operation PMCS**

After using the CK, do **After Operation PMCS**

If you find something wrong when performing PMCS, fix it using troubleshooting and/or maintenance procedures. Pay attention to WARNING and CAUTION statements. A WARNING means someone could be hurt. A CAUTION means equipment could be damaged.

The right-hand column of the PMCS table lists conditions that make the CK not fully mission capable. Write up the faults that cannot be repaired on DA Form 2404 for unit maintenance. For further information on how to use this form, see DA PAM 738-750.

If any tools required to perform PMCS are not listed in the procedures, notify your supervisor.

Refer to TM 9-6115-642-10 for PMCS procedures for the generator.

Refer to TM 10-7310-281-13&P for PMCS procedures for the Modern Burner Unit (MBU).

Refer to TM 9-2330-328-14&P for PMCS procedures for the CK trailer, if applicable.

**INSPECTION**

Look for signs of trouble. Senses help here. You can feel, smell, hear, or see many problems that can be eliminated before they get worse. Inspect to see that items are in good condition. Are components correctly installed and secured? Is any damage to the frame or components visible? Correct any faults or notify unit maintenance.

---

**CONTAINERIZED KITCHEN (CK)  
PREVENTIVE MAINTENANCE CHECKS AND SERVICES (PMCS)**

---

0016 00

**LUBRICATION**

The only component of the CK requiring scheduled lubrication is the generator set. Refer to LO 9-6115-642-12 and TM 9-6115-642-10 for lubrication procedures. The container winches, door hinges, and corner jacks should be lubricated as necessary in accordance with the PMCS tables.

**CLEANING**

Proper cleaning of the CK and its components is an integral part of maintenance. It helps prevent possible problems in the future, so make it a habit to clean the CK and its components whenever necessary. Refer to TM 10-7310-281-13&P for proper cleaning procedures for the MBUs.

The generator set can be continuously operated at any time from no load up to and including rated load. At light loads (less than 25% of set rating), an oily residue (unburned fuel oil) may be noticed in the exhaust outlet and around connection joints in the exhaust system. This residue is caused by the inability of the fuel injection system to consistently meter the small amounts of fuel required to operate the generator with a light load. While this condition does not indicate a defect in the fuel system, the oily residue could affect engine performance and create a cosmetic problem on and around the generator set. Operation at rated load will burn off the oily residue in a short time, depending upon the amount present. The muffler may also need to be removed and cleaned if excessive buildup occurs. Increasing the electrical load on the set can prevent this oily residue.

**SPECIAL INSTRUCTIONS**

It is necessary for you to know how fluid leakage affects the status of the CK. Following are types/classes of leakage you need to know to be able to determine the status of the CK. Learn these leakage definitions and remember – when in doubt, notify your supervisor.

Class I: Seepage of fluid (as indicated by wetness or discoloration) not great enough to form drops.

Class II: Leakage of fluid great enough to form drops but not enough to cause drops to drip from the item being checked/inspected.

Class III: Leakage of fluid great enough to form drops that fall from the item being checked/inspected.

Equipment with minor fluid leaks (Class I or II) may be operated and is considered fully mission capable (refer to DA PAM 738-750). Of course, you must consider the fluid capacity in the item/system being checked/inspected. When in doubt, notify your supervisor.

When operating with Class I or II leaks, continue to check fluid levels as required by the PMCS tables. Class III leaks should be immediately reported to your supervisor.

**CONTAINERIZED KITCHEN (CK)  
PREVENTIVE MAINTENANCE CHECKS AND SERVICES**

**0016 00**

**THIS SECTION COVERS:**

Before Operation Preventive Maintenance Checks and Services (PMCS)

**INITIAL SETUP:**

Kitchen Set Up for Operation

**Maintenance Level:**

Operator/Crew

**Table 1. Before Operation PMCS for CK**

ITEM NO.	INTERVAL	MAN-HOUR	ITEM TO BE CHECKED OR SERVICED	PROCEDURE	EQUIPMENT NOT READY/ AVAILABLE IF:
1	Before		Container	<p>Inspect exterior of container for obvious weld cracks, damage to door hinges, handles, or seals. Check doors for freedom of movement. Lubricate door hinges as necessary (WP 0051 00, Table 1, Item 6.).</p> <p>Inspect cam locks for loose, missing or damaged hardware. Inspect weather seals for deterioration or damage.</p> <p>Inspect bullseye and wing levels for damage</p> <p>Inspect jacks for damage, missing parts, freedom of movement. Lubricate corner jacks as necessary (WP 0051 00, Table 1, Item 4).</p> <p>Inspect stair/ladders and railings for damage, cracked welds.</p> <p>Inspect winches for missing or damaged hardware, freedom of movement.</p> <p>Inspect winch cables for proper tension, routing and fraying.</p> <p>Inspect inner and outer fabric, floor covering and window screens for holes, tears, or loose seams. Inspect hook and loop closures for damage and proper operation.</p> <p>Inspect tie-down provisions for damage, loose or missing hardware</p>	<p>Container cracked or damaged.</p> <p>Cam locks damaged.</p> <p>Jack cracked or bent, locking pins missing.</p> <p>Any cracked welds.</p> <p>Missing or damaged hardware.</p> <p>Any frayed strand or more than one flat spot on cable.</p> <p>Damaged, loose, hardware missing.</p>

**CONTAINERIZED KITCHEN (CK)  
PREVENTIVE MAINTENANCE CHECKS AND SERVICES**

**0016 00**

**Table 1. Before Operation PMCS for CK - Continued**

ITEM NO.	INTERVAL	MAN-HOUR	ITEM TO BE CHECKED OR SERVICED	PROCEDURE	EQUIPMENT NOT READY/ AVAILABLE IF:
2	Before		Mechanical room	Inspect ratchet straps for fraying, cuts, damaged ratchet. Inspect rubber straps for cuts, missing or damaged hooks	Damaged straps or ratchets, hooks missing or damaged
3	Before		Cook center	Inspect intake and exhaust fans for damage, loose or missing parts.  Inspect awning assembly for damage.  Inspect cloth exhaust ducts for damage, proper installation.  Inspect base assembly for damage, weld cracks.  Inspect fuel line assembly for leaks, damage.  Inspect 24 VDC power cable assembly for frayed wires, damaged connectors.  Inspect ventilation hood assembly for loose, missing or damaged hardware. Check fans for proper operation.  Inspect grease filters and filter frame for loose, missing or damaged hardware or cracked welds. Check for grease accumulation. Clean filters as necessary.	Missing or damaged hardware.     Any fuel leak.  Frayed wire or damaged connector.  Fans inoperable.
4	Before		ECU filters	Inspect griddle, steam table, cook pot cradles and adapters, base rack, burner rack for cracks and damage.  Inspect filters for damage, cleanliness. Remove and clean as necessary	Damage, cracked weld.
5	Before		Dual oven assembly	Inspect ovens and base cabinet for damage, weld cracks, missing parts.  Inspect fuel line assembly for leaks, damage.  Inspect 24 VDC power cable assembly for frayed wires, damaged connectors.	Any fuel leak.  Frayed wire or damaged connector.

**CONTAINERIZED KITCHEN (CK)  
PREVENTIVE MAINTENANCE CHECKS AND SERVICES**

**0016 00**

**Table 1. Before Operation PMCS for CK - Continued**

ITEM NO.	INTERVAL	MAN-HOUR	ITEM TO BE CHECKED OR SERVICED	PROCEDURE	EQUIPMENT NOT READY/ AVAILABLE IF:
6	Before		Tray pack Heater	Inspect oven fan for damage, missing or damaged power cord.	Power cord missing or damaged.
				Inspect tray pack heater for loose, missing or damaged hardware or cracked welds.	Any water leak.
7	Before		Hand Sink Assembly	Inspect heater fan assembly for damage, missing or damaged power cord.	Power cord missing or damaged.
				Inspect sink and cabinet for damage, loose or missing hardware.	
				Inspect faucet, drain trap, and water lines for damage, missing parts.	
8	Before		Hose assemblies	Inspect water pump and water heater for damage, missing or damaged power cord.	Power cord missing or damaged.
				Inspect water supply and drain hoses for damage to hoses or connectors, missing washers.	
9	Before		Mobile Warming Cabinet	Inspect cabinet for damage. Inspect power cord for fraying or damaged connector.	Power cord missing or damaged.
10	Before		Refrigerators	Inspect cabinet for damage. Inspect power cord for fraying or damaged connector. Inspect door seal for damage and proper seal contact.	Damaged door seal. Power cord missing or damaged.
11	Before		Light fixtures	Inspect all light fixtures for damage, broken or missing bulbs. Inspect removable lights for frayed power cord, damaged connector.	Frayed wire or damaged connector.
				Turn on lights and check for proper operation in both normal and blackout modes.	
				Using the test switch on the fixture, check for proper operation of the emergency light.	
12	Before		Miscellaneous	Inspect mobile storage cabinets for any loose, missing or damaged hardware, cracked welds, damaged or missing casters.	



**CONTAINERIZED KITCHEN (CK)  
PREVENTIVE MAINTENANCE CHECKS AND SERVICES**

**0016 00**

**Table 1. Before Operation PMCS for CK - Continued**

ITEM NO.	INTERVAL	MAN-HOUR	ITEM TO BE CHECKED OR SERVICED	PROCEDURE	EQUIPMENT NOT READY/ AVAILABLE IF:
				<p>Inspect prep/serving tables and drawer assemblies for damage, missing parts.</p> <p>Check fire extinguishers for correct charge. Check inspection date on tag. Be sure to check the extinguisher in the mechanical room.</p> <p>Check first aid kit for expiration date, missing items.</p>	<p>Discharged or overdue for inspection.</p>

**CONTAINERIZED KITCHEN (CK)  
PREVENTIVE MAINTENANCE CHECKS AND SERVICES**

**0016 00**

**THIS SECTION COVERS:**

During Operation Preventive Maintenance Checks and Services (PMCS)

**INITIAL SETUP:**

Kitchen Set Up/Operating

**Maintenance Level:**

Operator/Crew

**Table 2. During Operation PMCS for CK**

ITEM NO.	INTERVAL	MAN-HOUR	ITEM TO BE CHECKED OR SERVICED	PROCEDURE	EQUIPMENT NOT READY/ AVAILABLE IF:
1	During		Cook center	<p>Monitor ventilation supply and exhaust fans for proper operation.</p> <p>Monitor MBUs for proper operation.</p> <p>Monitor grease filters for grease buildup. Remove and clean filters as necessary.</p> <p>Monitor grease cup and grease pan for grease accumulation. Empty and clean as necessary.</p>	<p>Ventilation or exhaust fan inoperable.</p> <p>MBU inoperable.</p>
2	During		Dual oven assembly	<p>Monitor MBUs and oven fan for proper operation.</p>	<p>MBU or oven fan inoperable.</p>
3	During		Tray pack heater	<p>Monitor MBU and heater fan for proper operation.</p>	<p>MBU or heater fan inoperable.</p>
4	During		Hand sink assembly	<p>Monitor water pump and water heater for leaks and proper operation.</p> <p>Monitor faucets, drain trap, and supply/drain water lines for leakage, proper operation.</p>	<p>Pump or water heater leaking or inoperable.</p>
5	During		Mobile warming cabinet	<p>Monitor cabinet for proper operation and temperature control.</p>	<p>Cabinet will not maintain temperature.</p>

**CONTAINERIZED KITCHEN (CK)  
PREVENTIVE MAINTENANCE CHECKS AND SERVICES**

**0016 00**

**Table 2. During Operation PMCS for CK – Continued**

ITEM NO.	INTERVAL	MAN-HOUR	ITEM TO BE CHECKED OR SERVICED	PROCEDURE	EQUIPMENT NOT READY/ AVAILABLE IF:
6	During		Refrigerators	Inspect door for proper seal contact. Check inside thermometer for proper temperature. Check operation of interior light.	Door not properly sealing. Will not maintain proper temperature.
7	During		ECU	Monitor for proper operation and excessive or unusual noise. Inspect filters and clean as necessary.	

**CONTAINERIZED KITCHEN (CK)  
PREVENTIVE MAINTENANCE CHECKS AND SERVICES**

0016 00

**THIS SECTION COVERS:**

After Operation Preventive Maintenance Checks and Services (PMCS)

**INITIAL SETUP:**

Kitchen Set Up/Not Operating

**Maintenance Level:**

Operator/Crew

**Table 3. After Operation PMCS for CK**

ITEM NO.	INTERVAL	MAN-HOUR	ITEM TO BE CHECKED OR SERVICED	PROCEDURE	EQUIPMENT NOT READY/ AVAILABLE IF:
1	After		Container	Inspect shelter fabric, floor covering and screens for holes, tears, or loose seams. Inspect hook and loop closures for damage and proper operation.  Inspect doors for damage to hinges, handles, or seals.  Inspect stair/ladders and railings for damage, cracked welds.	Damage, cracked weld.      Any leak. Pump or water heater inoperable.  Door not properly sealing.
2	After		Cook center	Inspect filters for grease accumulation. Remove and clean as necessary.	
3	After		ECU filters	Inspect filters for damage, cleanliness. Remove and clean as necessary.	
4	After		Dual oven assembly	Inspect ovens for cleanliness. Clean as necessary.	
5	After		Tray pack heater	Inspect interior of heater for cleanliness. Clean as necessary.	
6	After		Hand sink assembly	Inspect cabinet, sink, faucet for damage, evidence of leakage.	
7	After		Refrigerators	Inspect door seal for proper contact.	

END OF WORK PACKAGE

THIS PAGE INTENTIONALLY LEFT BLANK

**CONTAINERIZED KITCHEN (CK)  
UNIT MAINTENANCE PROCEDURES**

---

0017 00

**SHELTER ASSEMBLY**

**THIS SECTION COVERS:**

Inspect, Test, Replace, Repair

**INITIAL SETUP:**

CK set up for operation

**Maintenance Level**

Unit

**Tools and Special Tools**

Tool Kit, General Mechanic's (WP 0052 00, Table 1, Item 1)

**GENERAL**

This procedure contains information and instructions for inspecting and making repairs to the Shelter Assembly. Refer to WP 0034 00 for repair parts information.

**INSPECT**

Inspect the orange safety straps for cuts and signs of deterioration.

Inspect the winch cables for frayed wires or flat spots.

Inspect the tent and awning fabric for cuts or tears.

Inspect the exterior drain hose for cracks, cuts, and missing or damaged gaskets.

**TEST**

**Safety Strap:** Follow the Shelter Expansion procedure in WP 0006 00 to lower the applicable wing until the orange safety strap is almost tight. The orange safety strap is to be replaced if it is broken, frayed at the edges or it is evident that the strap will not support the weight of the shelter floor as it is being lowered. There is no repair for the safety strap. It must be replaced. Refer to the following section for the repair procedure.

**Winch Assembly:** Follow the Shelter Expansion or Wing Closure procedure as applicable to lower or raise the applicable wing. The winch should provide a smooth and even cranking operation. A clicking sound should be heard when the handle is rotated clockwise. There should not be a clicking sound when the crank is rotated counterclockwise. If a rough, intermittent, erratic or binding operation occurs, open the winch assembly access panel in the kitchen area and check that the winch cable is being properly wound on the winch cable reel assembly. Check the winch cable at each visible area at the container ends and along the wing. Continue the cranking operation if possible to check the cable along the entire length. The winch cable is to be replaced if any of the individual cable wires are broken, the cable is kinked or if there is more than one flat spot anywhere along the cable. Refer to the following section for the replacement procedure.

---

**CONTAINERIZED KITCHEN (CK)  
UNIT MAINTENANCE PROCEDURES**

---

0017 00

If the winch assembly cable is not binding, the winch assembly can be removed following the replacement procedure in the next section. After the winch assembly has been removed from the shelter, remove the handle retainer, assembly and brake cover. If the brake disks or any other part is cracked or broken within the winch assembly, the winch assembly requires replacement.

**Shelter and Awning Fabric:** Any tears in the fabric or awning that permit water to penetrate the shelter require maintenance. Follow the repair procedure below.

**Exterior Drain Hose:** Locate the source of drain hose leakage. If at the connector, check the connector gasket. If warped or cut, replace the gasket. If the leak is in the hose part of the assembly, the hose assembly will need to be replaced.

**REPLACE**

**Safety Strap:** The side wing of the shelter must be in the lowered position to replace a safety strap. Unbolt the strap from the shelter and retain the hardware. Install a new strap and bolt it in place.

**Winch Cable:** The side wing of the shelter must be in the lowered position to replace the winch cable. If the cable is badly damaged, use a forklift as a backup for the winch. Remove three wing jacks from the Mechanical Room if not already in place and install according to the setup procedure to support the side floor.

**WARNING**

**Use gloves while removing the winch cable from the winch drum.**

Remove the two access panels for the winch assembly and pulleys located to the left of the personnel access door. With one person using the winch crank and another person outside the kitchen area, unwind the cable from the winch while pulling the excess cable to the outside of the shelter. Remove the cable-retaining nuts on the winch assembly reel and while one person guides the cable through the shelter the other person coils the cable outside the shelter beside the side floor.

With one person guiding the cable through the tube of the side floor, the other person pulls the cable through the tube and coils the cable on the Mechanical Room end of the side floor. Continue pulling the cable through the tube until all the cable is coiled outside the Mechanical Room.

Locate the black plastic plug located in the upper back interior corner of the Mechanical Room on the same side as the cable being replaced. Remove the plug and locate the steel ferrule cable end in the hole. With a needle nose pliers, grasp the steel ferrule cable end and pull it clear of the wall. Continue pulling and guiding the cable through the hole.

---

**CONTAINERIZED KITCHEN (CK)  
UNIT MAINTENANCE PROCEDURES**

---

0017 00

To install a new cable, feed the end of the cable opposite the ferrule through the hole from inside the Mechanical Room. Avoid twisting and kinking the cable. Feed the end of the cable through the tube at the edge of the side floor. With one person pulling the cable through the tube and another person guiding the cable, continue routing the cable through the side floor tube until all excess cable is through the tube. Route the cable through the passage over the personnel door, over the pulley and down to the winch. Wind the cable onto the winch drum for a full turn and secure the cable to the drum using retained hardware. With one person guiding the cable from outside the shelter, another person winds the cable evenly onto the winch. Inspect the cable carefully and avoid twists or kinks as it winds onto the drum. Inspect the cable all the way along its path and make sure it is tight at the ferrule end in the Mechanical Room. Replace the black plastic plug.

**Winch Replacement:** With the side floor down and supported by wing jacks, or with the side floor up and the cam-locks locked, unwind the cable from the winch drum.

Remove the cable end from the drum by loosening the two hex nuts. Place the cable in loose coils on the kitchen floor.

Unfasten and retain the winch base bolts and remove the winch. Install the new winch with the retained hardware. Rewind the cable onto the new winch drum.

**Exterior Drain Hose:** If a quick-disconnect coupling is damaged or the hose is cut or cracked, no repair is possible. The hose assembly must be replaced. If a gasket is damaged, remove it from the coupling using needle nose pliers and replace it with a new one.

**Fabric Side:** The shelter wing must be fully lowered and supported by wing jacks to replace the fabric side. Remove all appliances and shelter arch components from the side to be replaced. Starting at the top edge of the container, remove and retain the machine screws and mounting plates along the top of the fabric side. Repeat the procedure along the sides of the container and along the perimeter of the wing floor. Loosen the hardware holding the rubber bumper along the edge of the wing if necessary to remove the fabric side. After all hardware has been removed, remove the fabric side.

Unfold the replacement fabric side. Align the top of the fabric at the top of the container. While holding the fabric side in place, install the mounting plates and machine screws along the top of the container. Repeat the procedure along the sides of the container. Bring the material down to the edge of the rubber bumper along the length of the wing edge and install the mounting plates and machine screws.

Install the shelter arch components and check the alignment of the fabric side and that all hardware has been properly installed.



---

**CONTAINERIZED KITCHEN (CK)  
UNIT MAINTENANCE PROCEDURES**

---

**0017 00**

**REPAIR**

**Fabric Repair, Outside Surface or Awning:** To repair a tear in the outer fabric or awning, use the fabric repair kit. Cut a patch of at least a one-inch greater size than the tear in all directions. Round the corners of the patch. Thoroughly clean the cover surface and roughen it with an abrasive file.

Apply an even coat of vinyl cement to both surfaces and let them dry for 2 to 5 minutes.

With an assistant supporting the vinyl from inside the shelter, press firmly to bond the surfaces. Allow twenty-four hours at 60 °F or more to cure before folding up the cover.

**Fabric Repair, Inside Surface:** With gray duct tape (or equal), cover the tear in the insulation area or tape a patch in place covering all edges. Cut a strip of tape longer than the tear in the inner liner.

Press one long edge of the tape to the area of the tear ensuring that the ends of the tape extend past the end of the tear on both ends. Close the tear and press the other side into the tape with an assistant on the outside providing support. The final appearance on the inside should be a nearly straight line following the original tear.

END OF WORK PACKAGE

---

**CONTAINERIZED KITCHEN (CK)  
UNIT MAINTENANCE PROCEDURES**

---

0018 00

**MECHANICAL ROOM**

**THIS SECTION COVERS:**

Inspect, Test, Replace

**INITIAL SETUP:**

CK set up for operation

**Maintenance Level**

Unit

**Tools and Special Tools**

Tool Kit, General Mechanic's (WP 0052 00, Table 1, Item 1)

**GENERAL**

This procedure contains information and instructions for inspecting and making repairs to various components in the CK Mechanical Room. Refer to WP 0035 00 for repair parts information. Electrical power components are included in the Electrical System Unit Maintenance Procedures. Fuel line and electrical cable procedures for components inside the kitchen area are included in the applicable Unit Maintenance Procedures for the individual component.

**INSPECT**

Inspect fuel lines for damaged connectors and lines.

Inspect 24 VDC power cables for frayed insulation and damaged connectors.

Inspect cloth exhaust ducts for cuts or tears.

Inspect air conditioner vibration mounts for damage or deterioration.

**TEST**

**Fuel Lines:** Refer to the troubleshooting procedures in the MBU manual to determine if the problem with the MBUs is caused by a fuel problem. If the problem is lack of fuel, check the connections at the fuel source, that the proper fuel is being used, and that the vent valve on the fuel can adapter is open. Check the fuel line connections at the fuel line tee on the left side of the Mechanical Room wall behind the generator for any signs of fuel leakage.

**24 VDC Electrical Cable:** Refer to the troubleshooting procedures in the MBU manual to determine if the problem with the MBUs is caused by an electrical problem. If there is an electrical problem, remove a 24 volt connector from any of the MBUs and check for 24 VDC. If there is no voltage, check the switch position on the MBU Converter (pulled forward position away from the wall) and the power connector. Remove the 24 VDC power connectors at the MBU Converter and check for 24 VDC. If the voltage is not 24 VDC, replace the MBU Converter. See the replacement procedure in the following section.

**CONTAINERIZED KITCHEN (CK)  
UNIT MAINTENANCE PROCEDURES**

0018 00

If the 24 VDC at the MBU Converter is correct, check the 24 VDC wiring to the kitchen area.

**Electrical Power:** See Power Entrance Panel: WP 0026 00

**Cook Center Fan Assemblies:** Rotate the fan control knob on the kitchen wall to the full clockwise position. To check the intake fan, remove the filter located on the air conditioning side of the Mechanical Room. Remove the cover from the fan and check the voltage. It should measure approximately 220 VAC. As the fan control is rotated counterclockwise position the voltage will decrease. If voltage is not present, check the circuit breaker and the voltage at the circuit breaker panel. If 220 VAC is present, the fan assembly needs to be replaced. Refer to the replacement procedure in the next section for access to the fan.

To check the exhaust fan, remove and retain the four mounting bolts on the exhaust duct and remove the fan assembly. Follow the procedure above to check fan operation.

**Environmental Control Unit (ECU):** The ECU is controlled from the wall switch in the food preparation area. If the ECU is not cooling or warming properly, check that the ECU Mode Switch in the food preparation area is set to the proper position. At the ECU Control Box located on the Mechanical Room wall behind the generator, next to the air conditioners, check the power supply output voltage at P5 (5 VDC) and P6 (12 VDC) as shown in Figure 1. If the voltage is not correct, replace the power supply. If the voltage is correct, perform the following diagnostic check to isolate the problem to an individual ECU and verify operation of the ECU control card.

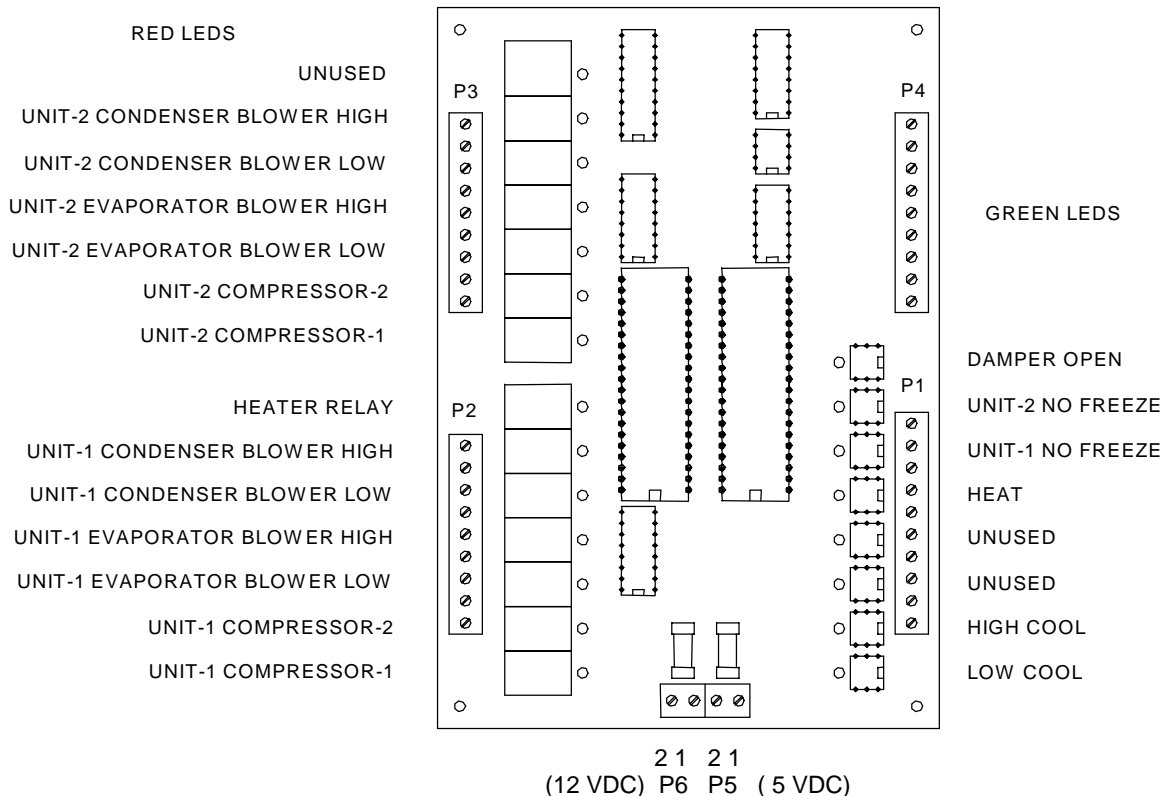

Figure 1. ECU Controller Board.

**CONTAINERIZED KITCHEN (CK)  
UNIT MAINTENANCE PROCEDURES**

**0018 00**

Remove the access panels of both air conditioners. Set the ECU Mode Switch in the operating area for High Cool. Monitor ECU operation by noting the LEDs as shown in Figure 1. LED configuration is also shown on the inside cover of the control box. As the air conditioners are automatically cycled through their operation (See Figure 2 for reference) note the sequence of events. As the LED turns on during the cycle, check the voltage at the air conditioner terminal board. A voltage of 12 VDC should be noted as each LED lamp comes on. See Figure 3.

Operation	Indicator Status (Green)	Indicator Status (Red)
A/C Off	Damper Open	
Low Cool (first 2 minutes)	Damper Open Low Cool	A/C 1, Compressor 1 A/C 1, Evaporator Blower Low A/C 1, Condenser Blower Low
Low Cool (second 2 minutes)	Damper Open Low Cool	A/C 1, Compressor 1 A/C 1, Compressor 2 A/C 1, Evaporator Blower Low A/C 1, Condenser Blower Low
High Cool (first 2 minutes)	Damper Open High Cool	A/C 1, Compressor 1 A/C 1, Evaporator Blower High A/C 1, Condenser Blower High
High Cool (second 2 minutes)	Damper Open High Cool	A/C 1, Compressor 1 A/C 1, Compressor 2 A/C 1, Evaporator Blower Low A/C 1, Condenser Blower Low
High Cool (third 2 minutes)	Damper Open High Cool	A/C 1, Compressor 1 A/C 1, Compressor 2 A/C 1, Evaporator Blower Low A/C 1, Condenser Blower Low A/C 2, Compressor 1 A/C 2, Evaporator Blower High A/C 2, Condenser Blower High
High Cool (fourth 2 minutes)	Damper Open High Cool	A/C 1, Compressor 1 A/C 1, Compressor 2 A/C 1, Evaporator Blower Low A/C 1, Condenser Blower Low A/C 2, Compressor 1 A/C 2, Compressor 2 A/C 2, Evaporator Blower Low A/C 2, Condenser Blower Low
Heat	Heat	A/C 1, Evaporator Blower High A/C 1, Heater Relay

Figure 2. Air Conditioner Sequential Status.

If the diagnostic sequence is correct and the output voltages (12 VDC) are correct at each terminal board connection on the air conditioner, the ECU controller board is functioning properly, and the fault is in the air conditioner. Replace the air conditioner using the procedure in the next section.

**CONTAINERIZED KITCHEN (CK)  
UNIT MAINTENANCE PROCEDURES**

0018 00

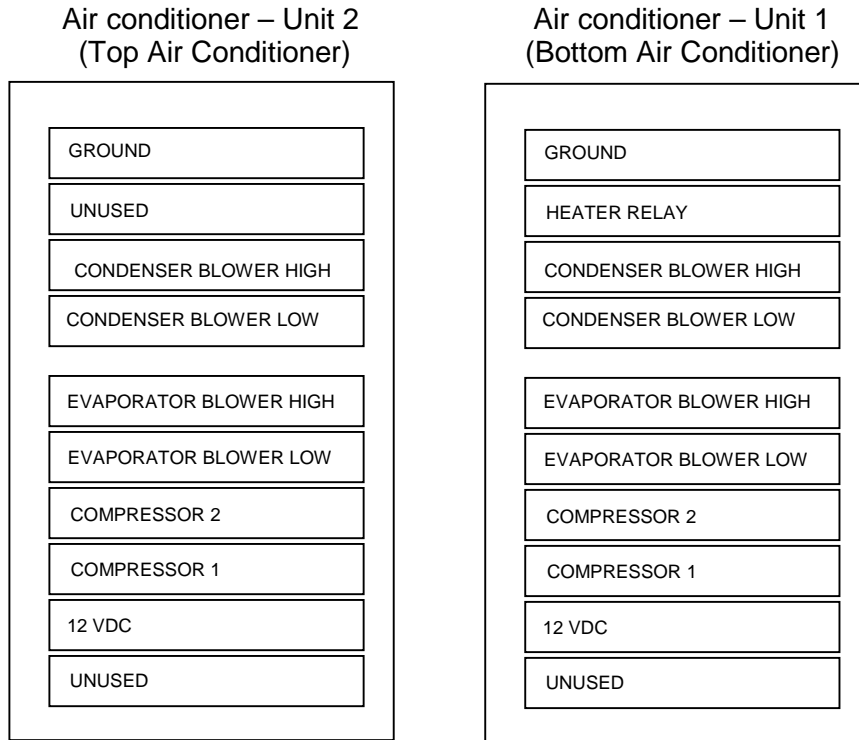

Figure 3. Air Conditioner Terminal Boards.

**Generator Set:**

Refer to the troubleshooting procedures in TM 9-6115-642-24 to test the generator set.

**REPLACE**

**WARNING**

**Before servicing any component of the mechanical room, turn OFF and tag or lock the required circuit breaker on the Power Distribution Panel. Ensure all power is off to the component being serviced.**

**Power Entrance Panel:** See WP 0026 00.

**MBU Converter:** Unplug the converter from its 115 VAC receptacle. Disconnect the 24 VDC output power connectors. Remove the mounting hardware and replace the converter. Reinstall hardware and connectors. Plug the converter power cable into the designated 115 VAC receptacle.

---

**CONTAINERIZED KITCHEN (CK)  
UNIT MAINTENANCE PROCEDURES**

---

0018 00

**Exhaust Fan:** Turn OFF and lock or tag Intake/Exhaust Fan circuit breakers #2 and #4 on the Power Distribution Panel. Remove and retain the four mounting bolts on the exhaust duct and remove the fan assembly. Disconnect the power cable and replace the fan using the retained hardware.

**Intake Fan:** Turn OFF and lock or tag Intake/Exhaust Fan circuit breakers #2 and #4 on the Power Distribution Panel. Remove the intake filter and disconnect the power cable. Remove and retain the fan mounting bolts. Install the replacement fan, replace the mounting bolts and connect the power cable. Insert the intake air filter in the duct.

**Air Conditioner:****WARNING**

**Shut off and tag the ECU circuit breaker at the Power Distribution Panel before performing any maintenance on the air conditioners.**

**Removal:** Shut off and tag the ECU circuit breaker at the Power Distribution Panel. Detach the fabric air duct. Remove the access panel from the side of the air conditioner. Label and disconnect the wires from the terminal block. Reattach the access panel. Disconnect the condensation drain line.

Remove the two access panels in the food preparation area. Remove the bolts connecting the air conditioner shock mounts to the support frame. A forklift is required to remove the air conditioner from the Mechanical Room. Using a forklift, lift the replacement air conditioner through the double doors of the Mechanical Room being careful that the air conditioner clears the doorway. Remove and retain the shock mounts.

**Install:** Install the shock mounts. Align the four mounting holes of the replacement air conditioner with the corresponding holes in the support frame. When the air conditioner is properly aligned, tighten all the mounting bolts.

Insert the power wiring through the hole in the electrical enclosure behind the electrical cover plate. Connect the power cables and attach the electrical enclosure cover plate.

Reattach the air duct and the condensation drain line. Install the two access panels in the food preparation area. Turn on power at the Power Distribution Panel and check for proper operation as described under TEST, earlier.

**ECU Controller Board:** The ECU Control Box (Figure 4) is located in the Mechanical Room next to the air conditioners. Make sure the Air Conditioner and the ECU Control circuit breakers on the Power Distribution Panel are turned OFF and tagged or locked. Open the front panel of the ECU Control Box and label the wires to terminal boards P1 through P5 as shown in Figure 1. Remove the wires and the four mounting screws. Install the replacement PC board and the mounting hardware. Reconnect all wires to the terminal boards P1 through P5. Turn on the circuit breakers and check the air conditioners for proper operation as described earlier under TEST.

**CONTAINERIZED KITCHEN (CK)  
UNIT MAINTENANCE PROCEDURES**

0018 00

**Power Supply:** The ECU Control Box is mounted on the rear wall of the Mechanical Room, next to the air conditioners. Make sure the Air Conditioner and ECU Control circuit breakers on the Power Distribution Panel are turned OFF and tagged or locked. Remove the mounting screws of the power supply board to permit disassembly of the wiring on top of the board. Label and disconnect the wires from the terminal strip.

Connect the wires to the replacement board and reassemble the mounting hardware. Turn on the circuit breakers and check the air conditioners for proper operation as described earlier under TEST.

**Relay:** Remove the spring clip holding the relay in its socket. Unplug the relay and plug in a new one. Replace the spring clip.

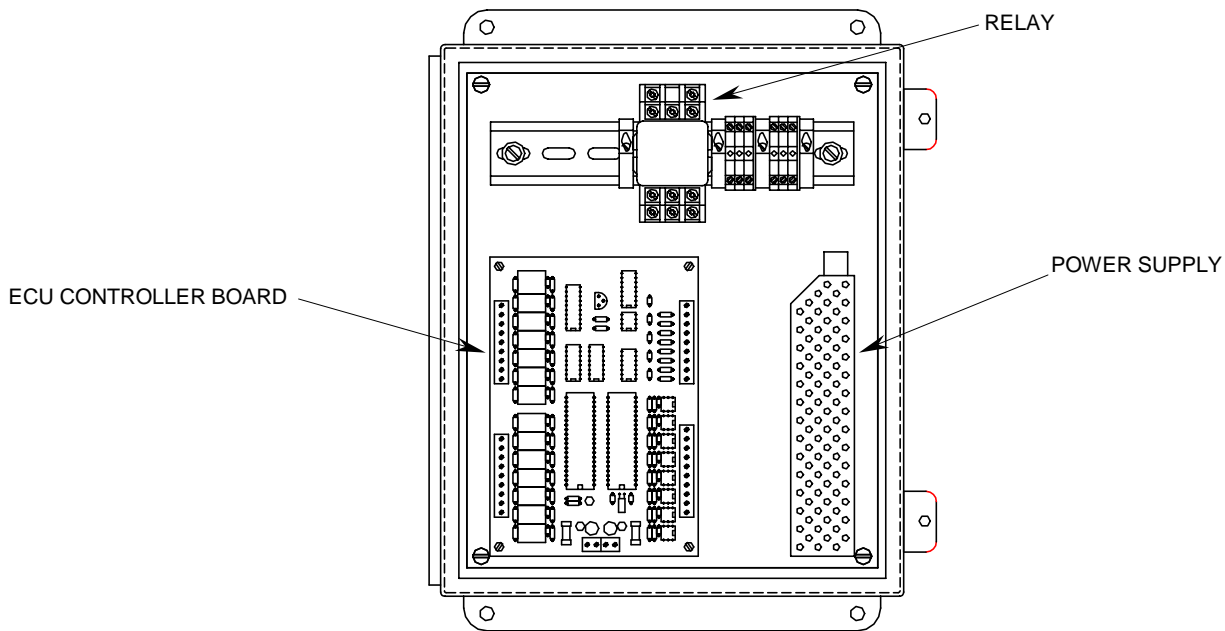

Figure 4. ECU Control Box Components.

**Generator:**

**WARNING**

**Disconnect all power from the CK and all load cables from the generator before removal.**

**Removal:** Make sure all power is disconnected from the CK. Remove the access panels that are located between the generator and the kitchen area wall. From the kitchen area disconnect the generator output terminals.

**CONTAINERIZED KITCHEN (CK)  
UNIT MAINTENANCE PROCEDURES**

---

**0018 00**

Remove the flexible exhaust pipe at the top of the generator. Remove and retain the hold down plates at the base of the generator. Leave the exhaust plenum attached the top of the generator.

A forklift is required to remove the generator from the Mechanical Room. Using a forklift of adequate capacity, remove the generator from the Mechanical Room being careful that that the generator clears the air conditioner brackets and the doorway.

Install all loose doors and hinges to the generator. Remove and retain the exhaust plenum.

**Install:** Attach the exhaust plenum to the top of the generator. Remove the control panel door and right side access door, leaving the hinges attached to the doors.

A forklift is required to install the generator into the Mechanical Room. Using a forklift of adequate capacity, install the generator into the Mechanical Room being careful that that the generator clears the air conditioner brackets and the doorway.

Attach the generator hold down plates using retained hardware. Connect the power cables to the output terminals of the generator set.

Install the hold-down brackets at the base of the generator set. Install the flexible exhaust pipe to the top of the generator. Place the previously removed access doors between the kitchen wall and the generator set. Close the mechanical room access doors.

END OF WORK PACKAGE



THIS PAGE INTENTIONALLY LEFT BLANK

---

**CONTAINERIZED KITCHEN (CK)  
UNIT MAINTENANCE PROCEDURES**

---

0019 00

**COOK CENTER**

**THIS SECTION COVERS:**

Inspect, Test, Replace, Repair

**INITIAL SETUP:**

CK set up for operation

**Maintenance Level**

Unit

**Tools and Special Tools**

Tool Kit, General Mechanic's (WP 0052 00, Table 1, Item 1)

**GENERAL**

This procedure contains information and instructions for inspecting, testing and repairing the CK Cook Center. Refer to WP 0036 00 for repair parts information.

**INSPECT**

Inspect the cook racks, griddle assembly, steam table and adapter top, cook pot cradles and exhaust hood assembly for loose hardware, broken welds and damaged rivets.

Tighten loose hardware as necessary. If frame welds are broken or loose, or a rivet is damaged, refer the repair to Direct Support maintenance.

Inspect the fuel line assembly for loose connections and damaged fuel line hoses and connectors.

Inspect the 24 VDC power cable assembly for loose connections and damaged wires or connectors.

**TEST**

**Fuel Line:** Refer to the troubleshooting procedures in the MBU manual to determine if the problem with the MBU is caused by lack of fuel. If none of the MBUs in the cook center are operational refer to the test procedures in WP 0018 00 to isolate the problem. Check the local fuel line from the main fuel line under the cook center to the MBU for signs of fuel leakage. Replace the hose assembly using the replacement procedure in the following section.

**24 VDC Electrical Cable:** Refer to the troubleshooting procedures in the MBU manual to determine if the problem with the MBU is caused by an absence of 24 VDC. If none of the MBUs in the cook center are operational, refer to the test procedure in WP 0018 00 to isolate

---

**CONTAINERIZED KITCHEN (CK)  
UNIT MAINTENANCE PROCEDURES**

---

0019 00

the problem. Remove the power connector at the MBU and check for 24 VDC. If voltage is present, recheck the procedures in the MBU manual. If 24 VDC is not present, remove the access cover on the 24 VDC elbow under the cook center and check voltage. If voltage is present, repair the cable using the repair procedure in the next section. If voltage is not present refer to the test procedure in WP 0018 00.

**REPLACE**

**Fuel Line:** If the fuel line is inoperable because of a damaged connector or a cut or hole in the hose, replace the entire section of fuel line assembly by disconnecting the hose assembly and installing a replacement. See Figure 1. Remove and replace the tie-wraps as required.

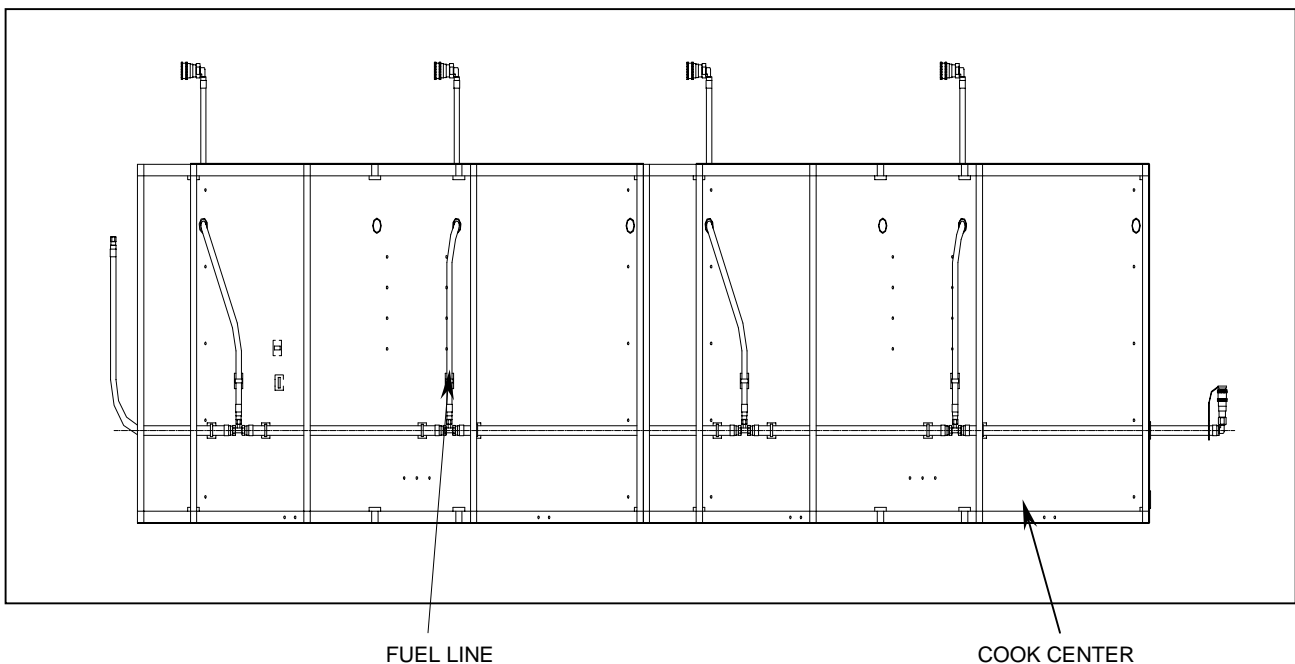

Figure 1. Cook Center Fuel Lines.

**REPAIR**

**MBU Cable Assembly:** Make sure the MBU Converter Circuit Breaker #11 on the Power Distribution Panel is turned OFF. To replace a damaged connector, disassemble the connector shell. Label and disconnect the two wires. Attach the wires to the new connector and reassemble the shell.

To repair a damaged cable, remove the cover of the junction box under the cook center, disconnect the wire nuts and pull the cable through the junction box and up through the cook center frame (see Figure 2). Cut a new cable to the desired length (WP 0045 00, Item 1) and

**CONTAINERIZED KITCHEN (CK)  
UNIT MAINTENANCE PROCEDURES**

0019 00

attach a connector to it. Slip the new cable down through the cook center frame and junction box. Attach the wire nuts and reassemble the junction box cover.

**MBU:** Refer to TM 10-7310-281-13&P for MBU repair procedures.

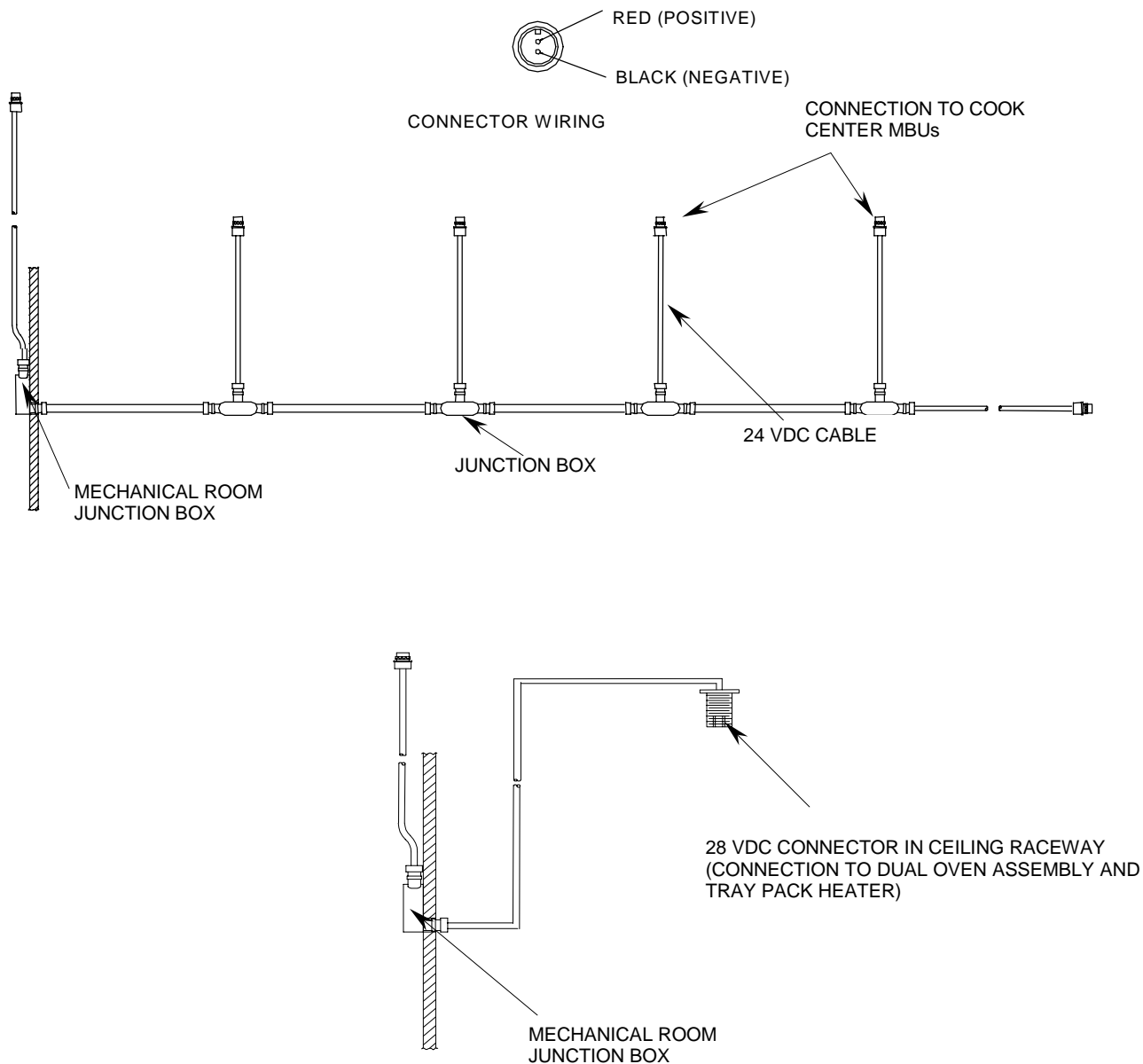

Figure 2. Cook Center 24 VDC MBU Cable Assembly.

END OF WORK PACKAGE

THIS PAGE INTENTIONALLY LEFT BLANK

---

**CONTAINERIZED KITCHEN (CK)  
UNIT MAINTENANCE PROCEDURES**

---

0020 00

**DUAL OVEN ASSEMBLY**

**THIS SECTION COVERS:**

Inspect, Test, Replace, Repair

**INITIAL SETUP:**

CK set up for operation  
Power cable, fuel line disconnected

**Maintenance Level**

Unit

**Tools and Special Tools**

Tool Kit, General Mechanic's (WP 0052 00, Table 1, Item 1)

**GENERAL**

This procedure contains information and instructions for inspecting, testing and repairing the CK Dual Oven Assembly. Refer to WP 0037 00 for repair parts information.

**INSPECT**

Inspect the oven base, ovens and fan assembly for loose hardware, damaged rivets and broken or loose welds. Inspect base casters for smooth operation. Tighten loose hardware. Refer broken or loose frame welds or damaged rivets to Direct Support maintenance.

**TEST**

**Fuel Line:** Refer to the troubleshooting procedures in the MBU manual to determine if the problem with the MBU is caused by lack of fuel. Check the fuel line connection at the wall to the Mechanical Room. Check all hose assemblies on the back of the oven assembly for signs of fuel leakage. Replace the hose assembly using the replacement procedure in the following section.

**24 VDC Electrical Cable:** Refer to the troubleshooting procedures in the MBU manual to determine if the problem with the MBU is caused by an absence of 24 VDC. Remove the power connector at the MBU and check for 24 VDC. If voltage is present, recheck the procedures in the MBU manual. If 24 VDC is not present, remove the connector on the ceiling duct labeled 28 VDC and check voltage. If voltage is present, repair the cable using the repair procedure in the next section. If voltage is not present refer to the test procedure in WP 0018 00.

**Castors:** Attempt moving the Dual Oven Assembly with the casters unlocked. It should move freely without binding of the casters. Move the Dual Oven Assembly in all directions to isolate the problem to a particular caster. Check for foreign material in the caster flanges.

---

**CONTAINERIZED KITCHEN (CK)  
UNIT MAINTENANCE PROCEDURES**

---

0020 00

**WARNING**

**Three people are required to lift one side of the Dual Oven Assembly for caster replacement .**

Place a wooden block under the frame near the faulty caster and check for free rotation. Replace the caster using the replacement procedure in the following section.

**Fan Assembly:** If the fan motor shaft is not rotating, check that the oven fan switch on the Appliance Control Box is ON and the power cable connected properly. Check the circuit breaker at the Appliance Control Box and the Power Distribution Panel. Remove the access cover at the fan assembly and check for 115 VAC. If voltage is not present recheck the cable assembly and connections. Replace the cable assembly if required. If voltage is present, replace the fan assembly. Refer to the following repair procedures.

**REPLACE****Caster:****WARNING**

**Three people are required to lift one side of the Dual Oven Assembly for caster replacement**

Place a wooden block under the Dual Oven Assembly in the vicinity of the caster as a support while the caster is being replaced (see Figure 1). Remove the four caster mounting screws and replace the caster. Replace all hardware.

**Fuel Line:** If the fuel line is inoperable because of a damaged connector or a cut or hole in the hose, replace the entire section of fuel line assembly by disconnecting the hose assembly and installing a replacement (see Figure 2).

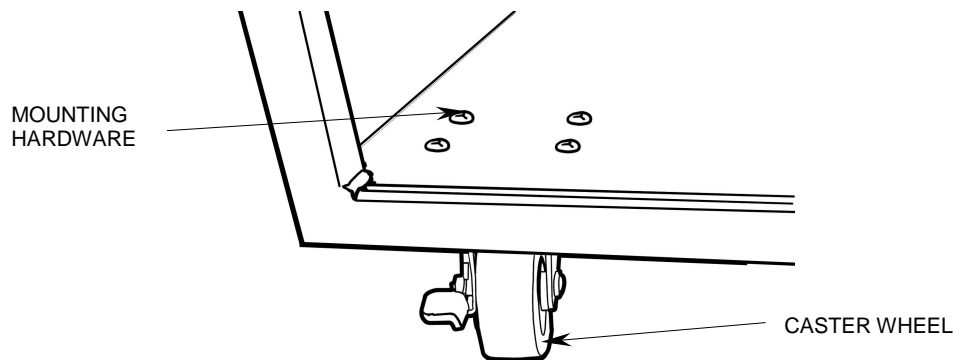

Figure 1. Swivel Caster Replacement.

**CONTAINERIZED KITCHEN (CK)  
UNIT MAINTENANCE PROCEDURES**

0020 00

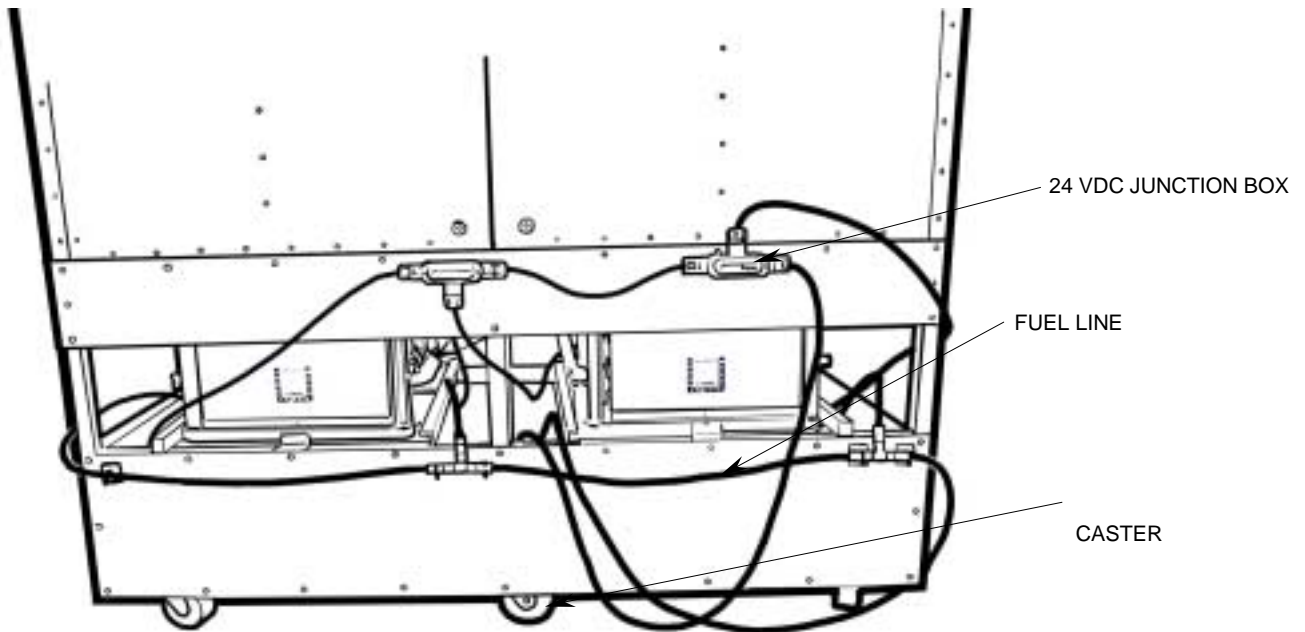

Figure 2. Dual Oven Assembly Fuel Line Maintenance.

**REPAIR**

**MBU Cable Assembly:** To replace a 24 VDC cable, remove the cover of the junction box, label and disconnect the wires and pull the cable through the junction box. Cut a new cable to the desired length (WP 0045 00 Item 1) and attach a connector to it. Slip the new cable down through the junction box, connect the wires and replace the junction box cover.

**24 VDC Connector:** To replace a damaged connector, disassemble the connector shell. Label and disconnect the two wires. Attach the wires to the new connector and assemble it.

**MBU:** Refer to TM 10-7310-281-13&P for MBU repair procedures.

END OF WORK PACKAGE



THIS PAGE INTENTIONALLY LEFT BLANK

---

**CONTAINERIZED KITCHEN (CK)  
UNIT MAINTENANCE PROCEDURES**

---

**0021 00**

**MOBILE WARMING CABINET**

**THIS SECTION COVERS:**

Inspect, Test, Replace

**INITIAL SETUP:**

CK set up for operation  
Warming cabinet operational

**Maintenance Level**

Unit

**Tools and Special Tools**

Tool Kit, General Mechanic's (WP 0052 00, Table 1, Item 1)

**GENERAL**

This procedure contains information and instructions for inspecting and repairing the Mobile Warming Cabinet. Refer to WP 0038 00 for repair parts information.

**WARNING**

**Unplug the power cord before performing any maintenance on the warming cabinet.**

**INSPECT**

Inspect the door gaskets and door seals for signs of wear or damage.

**TEST**

**Cabinet:** If the warming oven is not heating at all, check that the warming oven power cord is connected properly, the master switch is On and the circuit breaker at the Power Distribution Panel is On. Disconnect the power cord and remove the Module using the procedure in the following section. Temporarily connect the power cord and check for 115 VAC at the power switch. If voltage is present on both sides of the switch the module requires replacement. Replace the power switch if required.

If the temperature in the warming oven is erratic or cannot be controlled, check the voltage at the thermostat. Rotate the thermostat control while checking voltage. A smooth change in voltage over the range of the thermostat should be noted. Replace the thermostat if necessary.

If the warming oven is operating normally but the indicator lamps are not lit, check voltage at the terminal block and replace the indicator lights if necessary.

---

**CONTAINERIZED KITCHEN (CK)  
UNIT MAINTENANCE PROCEDURES**

---

0021 00

If insufficient warming of the Cabinet is noted, visually check the door seals and gasket for warpage or deteriorated condition of the seals. If the warming oven is on, it may be possible to detect a deteriorated gasket by noting loss of internal heat to the outside.

**Casters:** Attempt moving the Mobile Warming Cabinet with the casters unlocked. It should move freely without binding of the casters. Move the cabinet in all directions to isolate the problem to a particular caster. Check for foreign material in the caster flanges. Refer to the procedure in the following section to replace a caster.

**REPLACE****Cabinet Parts**

**Caster:** The front casters are equipped with a wheel brake. Rear casters do not have a brake. If necessary, a caster with a brake can be installed as a rear caster leaving the brake unlocked.

**WARNING**

**Two people are required to lay the Mobile Warming Cabinet on its back.**

To replace a front or rear caster, lay the cabinet on its back, remove the module, and remove caster mounting hardware and caster. Replace caster using existing hardware. Replace the module.

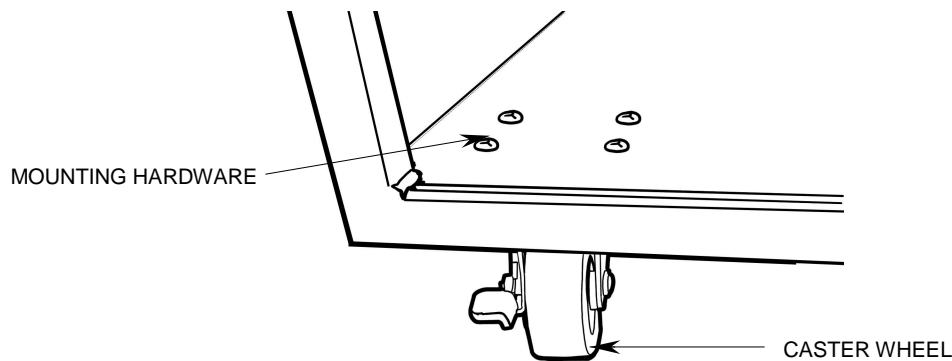

Figure 1. Swivel Caster Replacement.

**Door Gasket:** Refer to Figure 2. Starting at a corner, remove the old gasket from the door by pulling it out of the groove in the door frame. To install the replacement gasket, press the arrow-shaped edge of the new gasket into the groove. It may take up to eight hours depending on the ambient temperature for the gasket to seat properly.

**CONTAINERIZED KITCHEN (CK)  
UNIT MAINTENANCE PROCEDURES**

0021 00

**Door Seal:** Refer to Figure 2. Remove and retain the five door seal mounting screws and the door seal retaining strip. Install the new door seal using retained hardware.

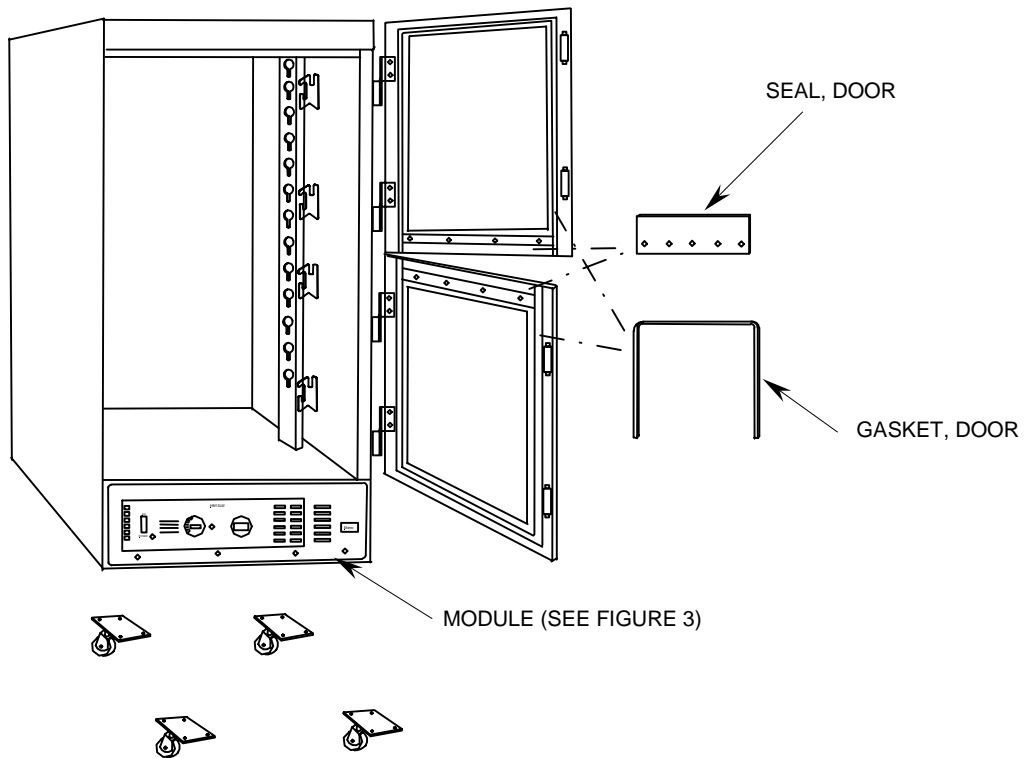

Figure 2. Mobile Warming Cabinet Maintenance.

**Module**

The module (Figure 3) is removed from the cabinet using the following procedure:

Make sure the power cord is unplugged and that the module has cooled to a temperature safe for handling.

Open the bottom door. Remove the module by lifting the front enough to clear the detent, then pull the module from the cabinet. The power cord should slip through the clearance hole in the back of the cabinet.

Unfasten the electrical cover by removing the screws along the front bottom of the module and the top panel. Remove the water pan from the top cover. Open the module by lifting the unit from the chassis. Turn the unit over for access to the components.

---

**CONTAINERIZED KITCHEN (CK)  
UNIT MAINTENANCE PROCEDURES**

---

0021 00

**Power Cord:** Label and disconnect the power cord wires. Using pliers, squeeze the strain relief from inside and push out.

Slip the replacement power cord through the strain relief and then through the mounting hole. Connect the black and white wires and the green ground wire. Snap the strain relief in place.

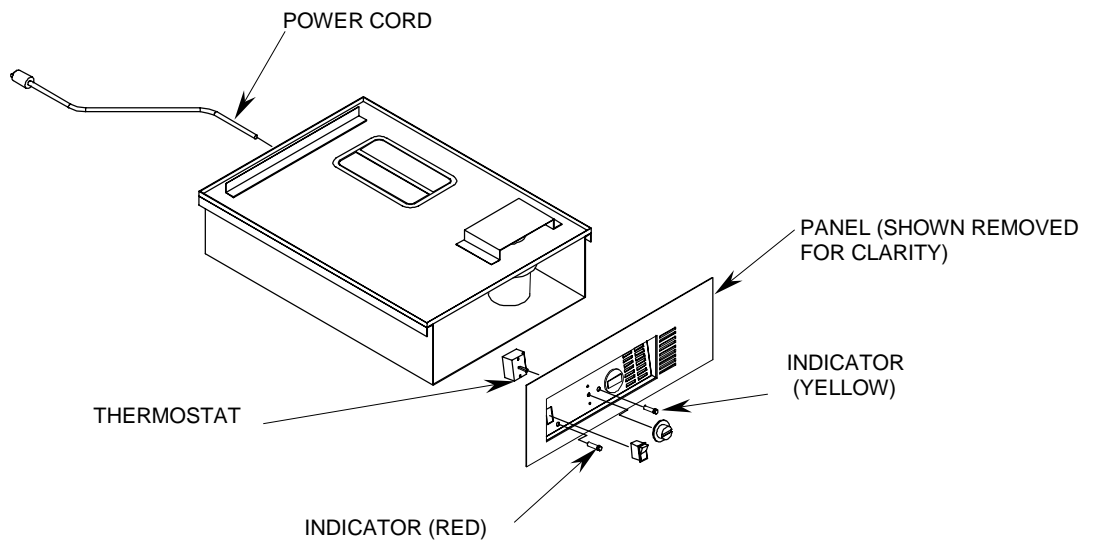

Figure 3. Cabinet Module.

**Thermostat:** Pull the control knob from the thermostat to expose the two mounting screws. Remove and retain the mounting screws and pull the thermostat from the control panel to gain access to the ring terminal connections. Replace the thermostat and retained hardware.

**Indicator Light (yellow):** Using a small screwdriver, pry loose the clip retaining the indicator light to be replaced. Trace the two wires from the fan to the terminal block, label the wires and disconnect them. Draw the indicator light and wire through the control panel.

Install the new indicator light. Affix crimp-on spade terminals to each wire lead. Feed the new light through the hole in the panel and press on the retaining clip. Connect the leads to the terminal block.

**Power Indicator Light (red):** Trace the two wires running from the light to the terminal block, label the wires and disconnect them. Pry loose the clip retaining the light. Depress the tabs on the light body and draw it through the hole in the control panel. Replace the light. Affix crimp-on spade terminals to each wire lead. Connect the wires to the terminal block.

**Power Switch:** Label and disconnect the wires connected to the switch. Depress the tabs on the switch and push the switch back through the control panel. Snap the new switch into place and reconnect the wires.

END OF WORK PACKAGE

---

**CONTAINERIZED KITCHEN (CK)  
UNIT MAINTENANCE PROCEDURES**

---

0022 00

**REFRIGERATOR**

**THIS SECTION COVERS:**

Inspect, Test, Replace

**INITIAL SETUP:**

CK set up for operation  
Refrigerator power cord unplugged

**Maintenance Level**

Unit

**Tools and Special Tools**

Tool Kit, General Mechanic's (WP 0052 00, Table 1, Item 1)

**GENERAL**

This procedure contains information and instructions for inspecting and repairing the refrigerator. Refer to WP 0039 00 for repair parts information.

**WARNING**

**Unplug the power cord before performing any maintenance on the refrigerator.**

**INSPECT**

Inspect the door gasket for tears, cuts or deterioration that would prevent an adequate seal. Inspect the shelf brackets for damage. Inspect the interior and exterior for dirt and foreign materials that could cause a malfunction or restrict air flow. Inspect the swivel casters for smooth operation. Inspect the power cord and plug for damage.

**TEST**

**Refrigeration Unit:** If the refrigerator is not cooling at all, check that the circuit breaker on the Power Distribution Panel is ON and that the refrigerator power cord is properly connected. Unplug the refrigerator and remove the screws from the access cover at the bottom rear of the refrigerator. Unplug the connector at the bottom of the refrigerator and temporarily connect the power cord to the 115 VAC outlet. If 115 VAC is present at the refrigerator end of the cord, the refrigerator needs to be replaced. If 115 VAC is not present, recheck all power connections and the power cord. Replace the power cord following the procedure in the next section.

If the refrigerator is not cooling sufficiently as indicated by the thermometer, turn the temperature controller clockwise and determine if the compressor turns on and the temperature gradually decreases. If it does not the temperature controller needs to be replaced. Follow the replacement procedures in the next section. If the temperature controller is operating normally, check the door gasket for leaks. This test can be performed by detecting cold air around the

---

**CONTAINERIZED KITCHEN (CK)  
UNIT MAINTENANCE PROCEDURES**

---

0022 00

perimeter of the door and by visually inspecting the entire gasket for hardness, cuts and a deteriorated condition.

**Casters:** Attempt moving the refrigerator with the casters unlocked. It should move freely without binding of the casters. Move the refrigerator in all directions to isolate the problem to a particular caster. Check for foreign material in the caster flanges. Refer to the procedure in the following section to replace a caster.

**REPLACE**

**Power Cord:** Make sure the power cord is unplugged from the electrical outlet. Remove the screws from the access cover at the bottom rear of the refrigerator. Unplug the connector and remove the green ground wire. Install the replacement power cord and securely connect the green ground wire.

**Temperature Controller:** See Figure 1. Remove the five machine screws from the fan/controller panel at the inside top of the refrigerator. Loosen the panel from the side molding strips being careful not to damage the trim or the wiring behind the panel. Disconnect the temperature-controller connector. Remove the mounting hardware of the temperature controller. Install the replacement controller using existing hardware. Reinstall the fan/controller panel and slide the side molding strips onto the edges of the panel.

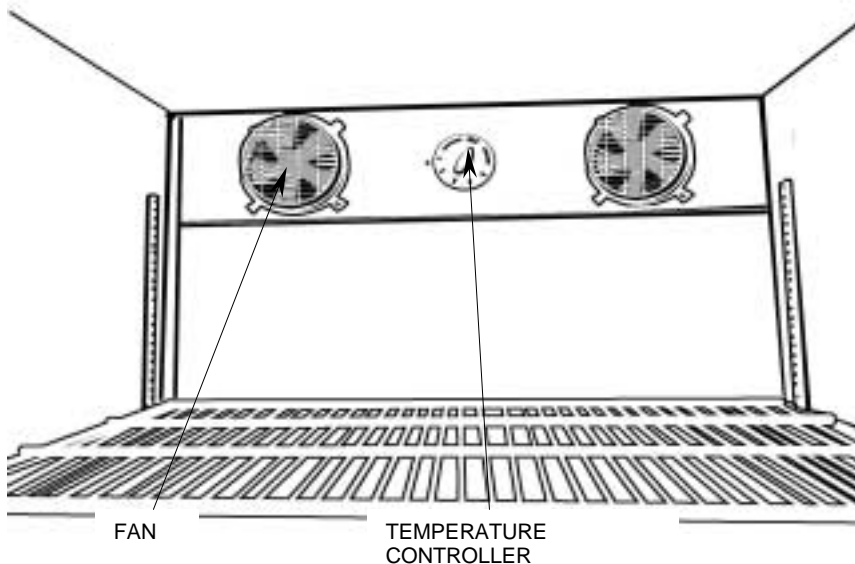

Figure 1. Refrigerator Interior.

**Door Gasket:** Remove the screws from underneath the gasket material. Align the new gasket around the door so that the screw holes are aligned. Replace all hardware.

---

**CONTAINERIZED KITCHEN (CK)  
UNIT MAINTENANCE PROCEDURES**

---

0022 00

**Caster:** See Figure 2. To replace a front caster, unsnap and remove the grille at the bottom of the refrigerator, then remove the drip pan. To replace a rear caster, remove the access cover at the bottom rear of the unit.

**WARNING**

**Two people are required to lay the refrigerator on its back.**

Place the refrigerator on its back on the kitchen floor. Check the faulty caster for free rotation. Remove the hex nut and the caster. Install the new caster and hex nut. Place the refrigerator in its upright position. As applicable, reinstall the drip pan, grille, and access cover. If possible, allow the refrigerator to remain in its upright position for an hour before applying power.

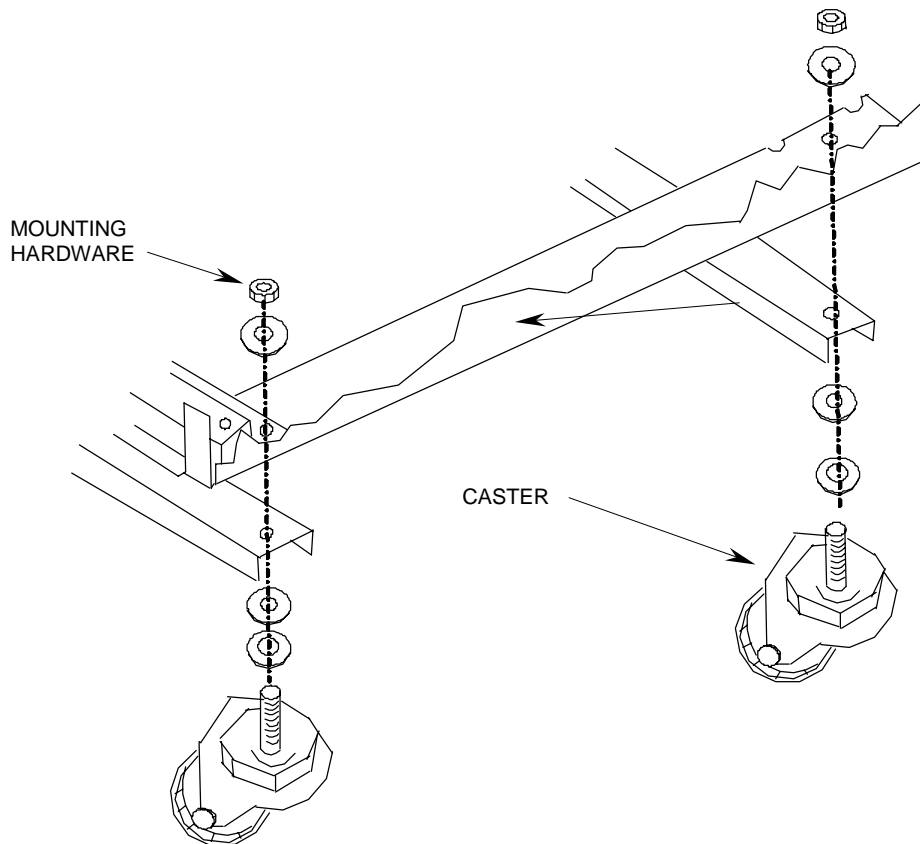

Figure 2. Swivel Caster Replacement.

END OF WORK PACKAGE



THIS PAGE INTENTIONALLY LEFT BLANK

---

**CONTAINERIZED KITCHEN (CK)  
UNIT MAINTENANCE PROCEDURES**

---

**0023 00**

**TRAY PACK HEATER**

**THIS SECTION COVERS:**

Inspect, Test, Replace

**INITIAL SETUP:**

CK set up for operation

Heater fan assembly unplugged

**Maintenance Level**

Unit

**Tools and Special Tools**

Tool Kit, General Mechanic's (WP 0052 00, Table 1, Item 1)

**GENERAL**

This procedure contains information and instructions for inspecting and repairing the Tray Pack Heater. Refer to WP 0040 00 for repair parts information.

**INSPECT**

Inspect the Tray Pack Heater and the heater fan assembly for loose hardware and damaged rivets. Inspect the fan assembly power cable for damage.

**TEST**

**Casters:** Disconnect the fuel line and power cord. Attempt moving the Tray Pack Heater with the casters unlocked. It should move freely without binding of the casters. Move the cabinet in all directions to isolate the problem to a particular caster. Check for foreign material in the caster flanges. Refer to the procedure in the following section to replace a caster.

**Drain Valve:** Check for external leakage of the drain and that it is not clogged with foreign material. Replace the drain valve if necessary following the procedure in the next section.

**Heater Fan:** If the fan motor shaft is not rotating, check that the power switch on the appliance control box is ON and the power cable properly connected. Check the circuit breakers at the Appliance Control Box and the Power Distribution Panel. Remove the access cover at the fan assembly and check for 115 VAC. If voltage is not present recheck the cable assembly and connections. Replace the cable assembly if required. Check the heater fan receptacle by plugging the fan cable into a different receptacle. If voltage is present, replace the fan assembly. Refer to the following repair procedures.

---

**CONTAINERIZED KITCHEN (CK)  
UNIT MAINTENANCE PROCEDURES**

---

0023 00

**REPLACE**

**Caster:** See Figure 1. Drain the Tray Pack Heater. Support the Tray Pack Heater with a wooden block in the vicinity of the caster while the caster is being replaced. Remove the four bolts and the damaged caster. Install the new caster and mounting hardware.

**Drain Valve:** See Figure 1. Drain any liquid from the Tray Pack Heater. Remove the drain valve and replace using pipe joint compound (WP 0051 00, Table 1, Item 3) as required.

**Heater Fan:** Disconnect the fan assembly power cord. Remove and retain the fan assembly mounting hardware. Install the replacement fan using the retained hardware.

**Lifting Handles:** Refer any damage to the lifting handles to Direct Support maintenance.

**MBU:** Refer to TM 10-7310-282-13&P for MBU repair procedures.

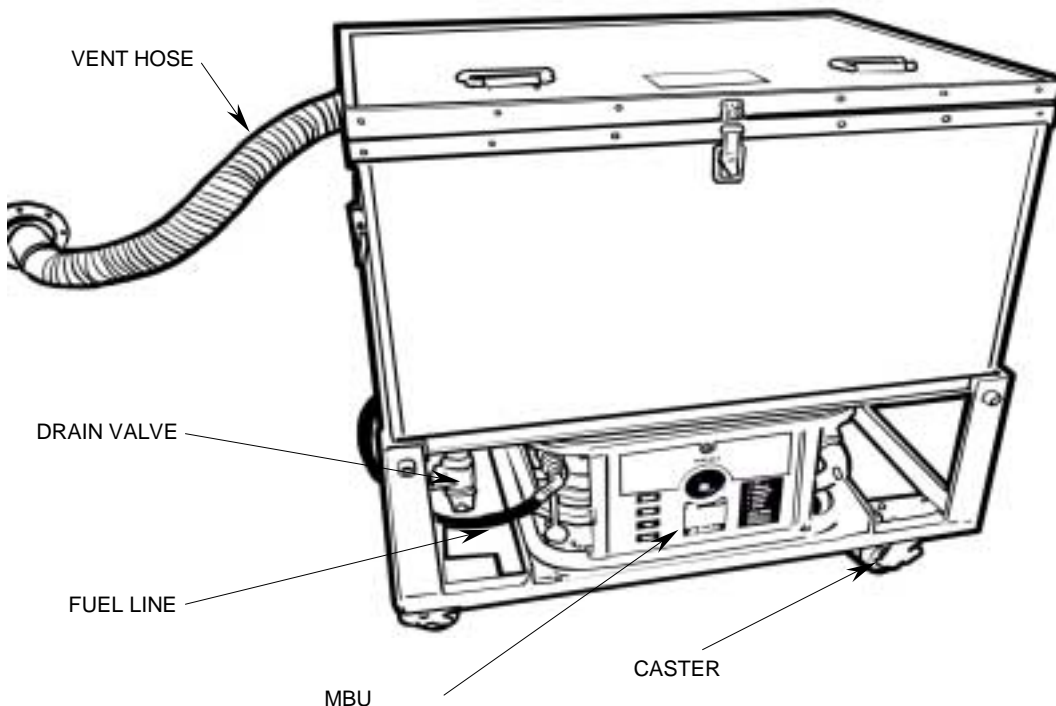

Figure 1. Tray Pack Heater Components.

END OF WORK PACKAGE

---

**CONTAINERIZED KITCHEN (CK)  
UNIT MAINTENANCE PROCEDURES**

---

**0024 00**

**HAND SINK ASSEMBLY**

**THIS SECTION COVERS:**

Inspect, Test, Replace

**INITIAL SETUP:**

CK set up for operations

Water pump and water heater connected to the Appliance Control Box

Water supply hose connected

Drain hose connected

**Maintenance Level**

Unit

**Tools and Special Tools**

Tool Kit, General Mechanic's (WP 0052 00, Table 1, Item 1)

**GENERAL**

This procedure contains information and instructions for inspecting and repairing the Hand Sink Assembly. Refer to WP 0041 00 for repair parts information.

**WARNING**

**Disconnect the pump and water heater power cables from the Appliance Control Box before making any repairs to the sink assembly.**

**WARNING**

**The water in the hot water tank may be hot. Allow the water to cool before opening the drain valve.**

**INSPECT**

Inspect water connections for leaks at the pump head, in the area around the water heater, and the faucet above and below the sink. Inspect electrical connectors and cords for damage. Inspect the water supply hoses and interior drain hose for damage, missing or damaged washers or gaskets.

---

**CONTAINERIZED KITCHEN (CK)  
UNIT MAINTENANCE PROCEDURES**

---

0024 00

**TEST**

**Pump Assembly:** Run faucet water into the sink. The pump should run periodically. Check the pump assembly by temporarily connecting the pump assembly power cord to the Appliance Control Box and check for 115 VAC at the pressure switch. Disconnect the power cord from the appliance control box. Replace the pump if necessary.

**Water Heater:** The water heater can be tested by removing the access cover at the side of the tank. Temporarily connect the water heater power cord to the appliance control box and check for 115 VAC between terminals 1 and 3 (refer to wiring diagram on side of water heater). Depress the reset button and recheck voltages. If the 115 VAC is present the water heater should be replaced following the procedure in the next section. If the 115 VAC is not present, check the power cord and refer to WP 0018 to check power distribution. Disconnect the power cord from the appliance control box.

**Casters:** Disconnect the power cords from the Appliance Control Box. Attempt moving the sink assembly with the casters unlocked. It should move freely without binding of the casters. Move the sink in all directions to isolate the problem to a particular caster. Check for foreign material in the caster flanges. Refer to the procedure in the following section to replace a caster.

**REPLACE**

**Caster:** The sink assembly contains locking casters in the front of the assembly and non-locking casters in the back. Locking casters may be used as replacements for non-locking casters with the caster left in the unlocked position. See Figure 1. To replace a caster (front or back) remove the four screws from the mounting plate and the damaged caster. Replace the caster and reinstall the four screws.

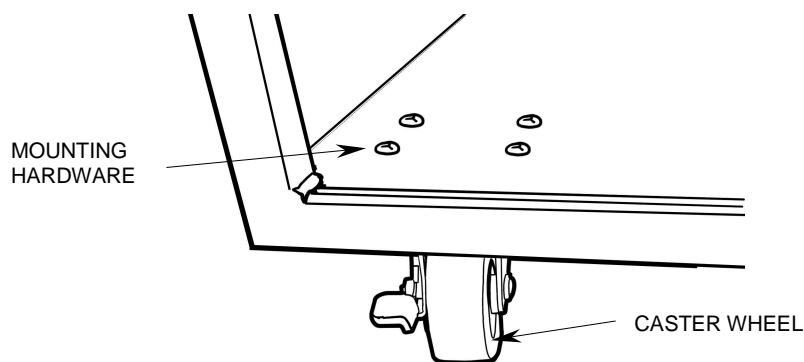

Figure 1. Swivel Caster Replacement.

---

**CONTAINERIZED KITCHEN (CK)  
UNIT MAINTENANCE PROCEDURES**

---

0024 00

**Water Heater:** See Figure 2. To replace the water heater, disconnect the power cord at the bottom of the tank. Allow the water in the tank to cool, open the drain valve and drain the water into an empty bucket or drain system. Remove the locking nuts from the mounting bracket at the side of the sink assembly. Remove the supporting bracket under the water heater and lift the water heater out of the sink assembly.

Remove and discard the curved bracket attached to the side of the replacement water heater. Remove this same bracket from the side of the bad water heater and install it onto the replacement water heater.

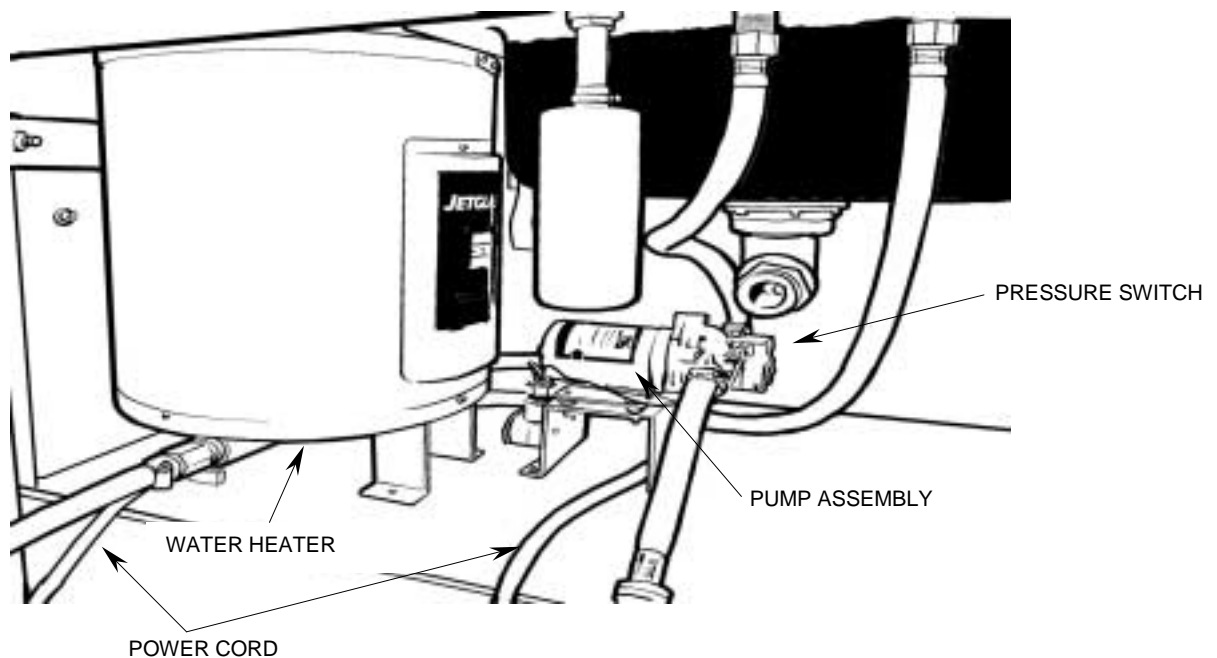

Figure 2. Sink Assembly Maintenance.

Install the replacement water heater, reinstall the mounting hardware, hoses, and the electrical connector.

**Pump Assembly:** See Figure 2. To replace the pump assembly, label the wires and disconnect the power cord at the junction box on the pump assembly mounting bracket. Remove the four screws from the pump assembly mounting plate. Retain the rubber mounting spacers.

Install the replacement pump, the four mounting spacers and screws on to the mounting plate. Reconnect the power cord to the junction box.

---

**CONTAINERIZED KITCHEN (CK)  
UNIT MAINTENANCE PROCEDURES**

---

**0024 00**

**Faucet:** To replace the faucet, disconnect the hot and cold water supply lines under the sink. Remove the nuts and washers from the faucet pipes and remove the faucet. Insert a replacement faucet and reassemble the washers and nuts.

**Hoses:** If a water supply hose or the interior drain hose is damaged, replace it. If a washer or gasket is damaged, remove it with a small screwdriver or needle nose pliers and replace it with a new one.

END OF WORK PACKAGE

**CONTAINERIZED KITCHEN (CK)  
UNIT MAINTENANCE PROCEDURES**

---

0025 00

**MOBILE STORAGE CABINETS**

**THIS SECTION COVERS:**

Inspect, Test, Repair

**INITIAL SETUP:**

CK set up for operation

**Maintenance Level**

Unit

**Tools and Special Tools**

Tool Kit, General Mechanic's (WP 0052 00, Table 1, Item 1)

**GENERAL**

This procedure contains information and instructions for inspecting and making repairs to the Mobile Storage Cabinets. Refer to WP 0042 00 for repair parts information.

**INSPECT**

Inspect Mobile Storage Cabinets for broken welds, damaged rivets or damaged casters. Refer any sheet metal or weld repairs to Direct Support maintenance.

**TEST**

**Casters:** Attempt moving the storage cabinet with the casters unlocked. It should move freely without binding of the casters. Move the cabinet in all directions to isolate the problem to a particular caster. Check for foreign material in the caster flanges. Refer to the procedure in the following section to replace a caster.

**REPLACE**

**Caster:** Lay the cabinet on its back. Remove and retain the caster mounting hardware. Install the new caster using the retained hardware.

END OF WORK PACKAGE



THIS PAGE INTENTIONALLY LEFT BLANK

---

**CONTAINERIZED KITCHEN (CK)  
UNIT MAINTENANCE PROCEDURES**

---

0026 00

**ELECTRICAL SYSTEM**

**THIS SECTION COVERS**

Inspect, Test, Replace

**INITIAL SETUP**

CK set up for operation  
External power disconnected, generator shut down

**Maintenance Level**

Unit

**Tools and Special Tools**

Tool Kit, General Mechanic's (WP 0052 00, Table 1, Item 1)

**GENERAL**

This procedure contains information and instructions for inspecting, testing and making repairs to the CK electrical system. Refer to WP 0044 00 for repair parts information.

**WARNING**

**Disconnect the external power cable or ensure generator power is OFF before making repairs to the Power Entrance Panel, Power Distribution Panel, or Main Control Panel.**

**INSPECT**

Inspect the condition of each circuit breaker, ground, neutral, and 220v/115v connection at the Power Entrance Panel, Power Distribution Panel, Main Control Panel and Appliance Control Box. Inspect lighting fixtures for loose or damaged hardware, frayed power cord, and damaged connectors.

**TEST**

**Power Entrance Panel:** Using a multimeter, check the power voltage on both sides of the applicable circuit breaker the OFF position and ON position. With External Power ON at the Main Control Panel check the voltage at contactor CR2. If generator power is being used check voltage at contactor CR1. Follow the circuit diagrams in WP 0054 00 to check connections. Replace faulty component using the procedure in the following section.

**Appliance Control Box:** Using a multimeter, check the power voltage on both sides of the applicable circuit breaker and switch assemblies in the OFF position and ON position. Follow the circuit diagrams in WP 0054 00 to check connections. Replace faulty component using the procedure in the following section.

**CONTAINERIZED KITCHEN (CK)  
UNIT MAINTENANCE PROCEDURES**

0026 00

**Power Distribution Panel:** Using a multimeter, check the power voltage on both sides of the applicable circuit breaker in the OFF position and ON position. Follow the circuit diagrams in WP 0054 00 to check connections.

**Main Control Panel:** Using a multimeter, check the power voltage on both sides of the applicable switch assembly in the OFF position and ON position. Check voltage at the applicable lamp assembly. Follow the circuit diagrams in WP 0054 00 to check connections. Replace faulty component using the procedure in the following section.

**Lighting Fixture:** If the fluorescent lamps don't light upon replacement, remove the access plate on the fixture. Refer to the ballast wiring diagram in on the ballast to check output voltage. Replace the ballast if required using the procedure in the next section.

With the Interior Light switch ON and the Emergency Light switch OFF, depress the Test switch on the fluorescent light fixture above the personnel entrance door. The lamps on the fixture should be off. Turn the Emergency Light switch ON and depress the Test switch. The lamps should be on. If the battery charger in the light fixture fails to charge with the Emergency Light switch ON it requires replacement using the procedure in the following section.

**REPLACE**

**Power Entrance Panel**

**Power Connector:** Make sure all power is turned off at the Main Control Panel. Referring to Figure 1, disconnect the source power plug at the Power Entrance Panel and attach plug cover. Label and disconnect power leads from the external power contactor. Remove and retain connector mounting hardware and remove the connector. Install the replacement connector and retained hardware. Reconnect power leads at the contactor.

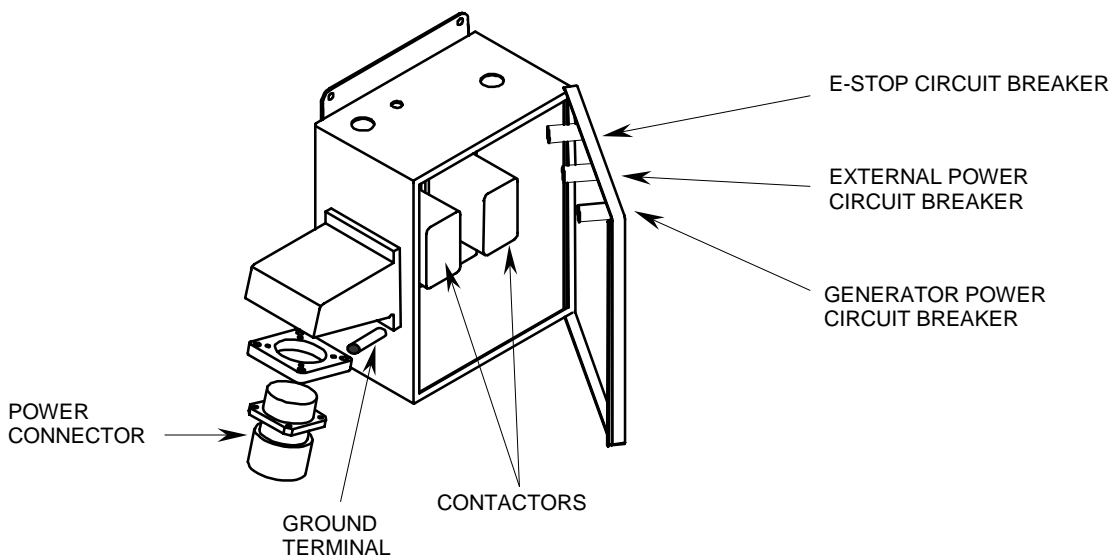

Figure 1. Power Entrance Panel.

---

**CONTAINERIZED KITCHEN (CK)  
UNIT MAINTENANCE PROCEDURES**

---

**0026 00**

**Ground Terminal:** Make sure all power is turned off at the Main Control Panel. Referring to Figure 1, disconnect the source power plug at the Power Entrance Panel and attach plug cover. Remove the mounting hardware from inside the Power Entrance Panel. Disconnect the green ground wires and remove the ground terminal from the outside of the panel box. Install the new ground terminal using existing hardware. Reconnect green wires.

**Contactors:** Make sure all power is turned off at the Main Control Panel. Referring to Figure 1, disconnect the source power plug at the Power Entrance Panel and attach plug cover. Label and disconnect spade terminals. Remove and retain the contactor mounting hardware. Install the replacement contactor using retained hardware.

If necessary, replace the circuit breaker by disconnecting the neutral and high voltage wires and installing a replacement.

Reconnect the wires and reinstall the panel cover.

**Appliance Control Box**

**Switch Replacement:** Unplug the control box power cord from the ceiling raceway. Referring to Figure 2, remove the mounting nut on the front of the panel. Remove terminal lugs from the switch and remove the switch from the back of the panel. Replace the switch, reinstall hardware and connect terminal lugs.

**Circuit Breaker Replacement:** Unplug the control box power cord from the ceiling raceway. Referring to Figure 2, depress the locking springs on the sides of the circuit breaker assembly and slide the circuit breaker through the front of the panel. Replace the circuit breaker and reconnect the terminal lugs.

**Connector Replacement:** Unplug the control box power cord from the ceiling raceway. Referring to Figure 2, label and disconnect the wires at the junction strip. Remove the mounting nut and the connector. Install the replacement connector using existing hardware.

**Power Distribution Panel**

**Circuit Breaker Replacement:** Make sure the external power source is disconnected and the generator is shut down. Remove the circuit panel cover. See Figure 3 for circuit breaker locations. Disconnect the neutral and high voltage wires and install a new circuit breaker. Reconnect the wires and reinstall the panel cover.

**CONTAINERIZED KITCHEN (CK)  
UNIT MAINTENANCE PROCEDURES**

0026 00

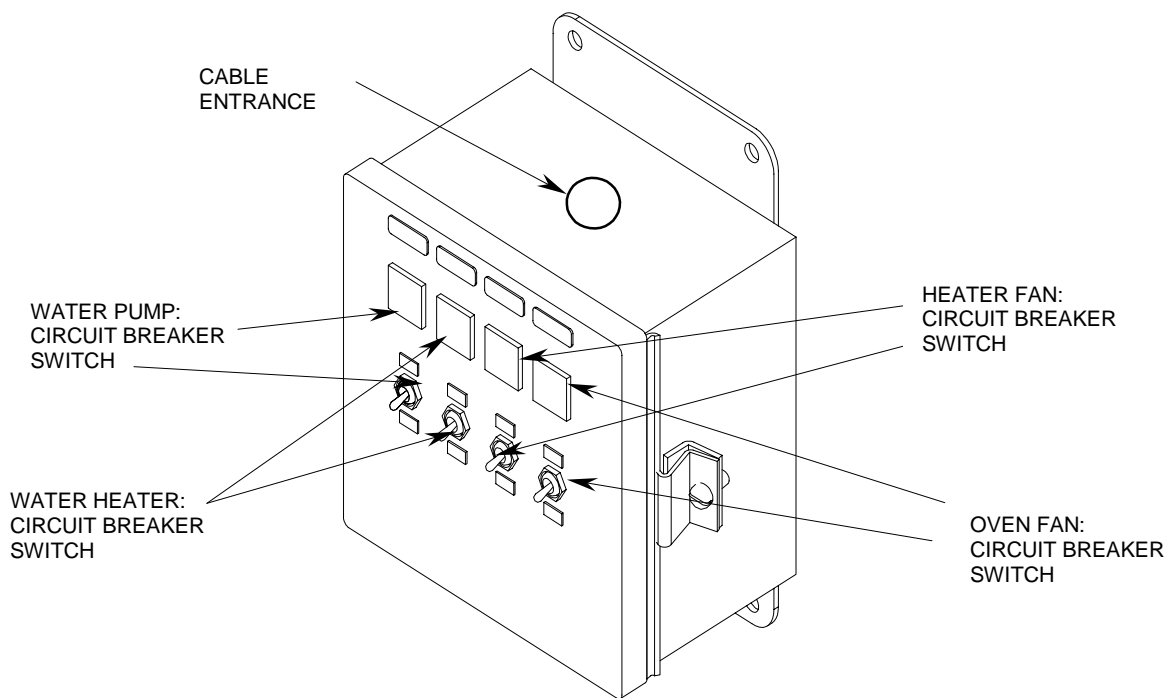

Figure 2. Appliance Control Box.

1	Input Power	2	Intake/Exhaust Fan
3	Input Power	4	Intake/Exhaust Fan
5	Input Power	6	Heater
7	Refrigerator 1	8	Heater
9	Refrigerator 2	10	Heater
11	MBU Converter	12	Convenience Outlets
13	ECU	14	Mechanical Room Outlet
15	ECU	16	Warming Cabinet
17	ECU	18	ECU Control Box
19	Lights	20	Blank/not used
21	Blank/not used	22	Blank/not used
23	Blank/not used	24	Appliance Control Box

Figure 3. Circuit Breaker Layout of the Power Distribution Panel.

**CONTAINERIZED KITCHEN (CK)  
UNIT MAINTENANCE PROCEDURES**

0026 00

**Main Control Panel:**

**Switch/Lamp Replacement:** Make sure the external power source is disconnected and the generator is shut down. Referring to Figure 4, label and remove the spade lugs from the switch/lamp to be replaced. Remove the mounting hardware from the front of the panel and remove the switch/lamp assembly. Install the replacement switch/lamp assembly, replace hardware and reconnect spade lug terminals.

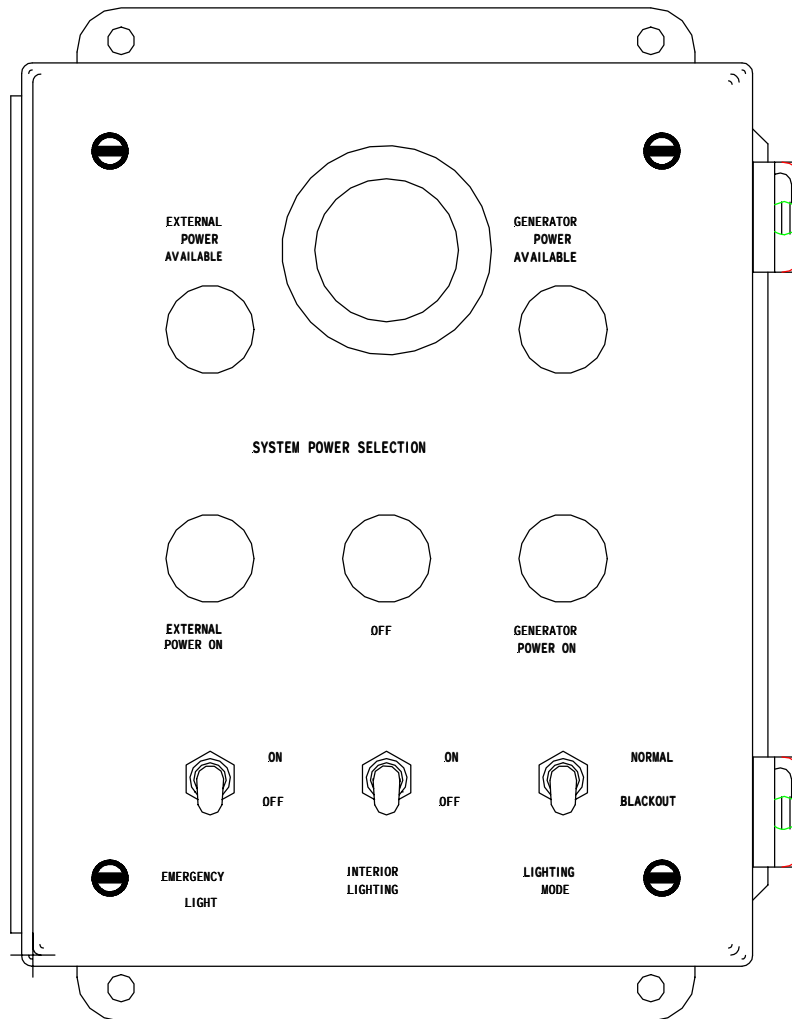

Figure 4. Main Control Panel.

---

**CONTAINERIZED KITCHEN (CK)  
UNIT MAINTENANCE PROCEDURES**

---

0026 00

**Lighting Fixtures**

**Permanently Mounted Fixture Ballast Replacement:** Turn off lighting system circuit breaker #19 on the Power Distribution Panel. Referring to Figure 5, remove the connectors at the fixture, tag the wires connected to the ballast and disconnect the wires. Remove the four machine screws from the ballast plate and remove the ballast.

Install the replacement ballast, connect wires and wire nuts. Attach access plate and tighten machine screw. Reconnect power line connectors.

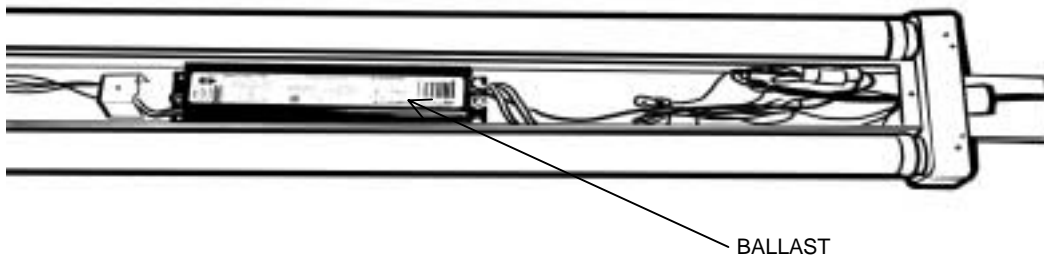

Figure 5. Lamp Assembly.

**Removable Fixture Ballast Replacement:** Remove the machine screw from the access plate and remove the plate. Label and disconnect the ballast wires. Remove the four machine screws from the ballast plate and remove the ballast.

Install the replacement ballast and connect wires and wire nuts. Attach the access plate and tighten the machine screw.

**Power cord:** Remove the machine screw from the access plate and remove the plate. Label and disconnect the power cord wires. Install a replacement power cord, connect wires and wire nuts. Attach access plate and tighten machine screw.

**Emergency Light Battery/Charger:** Turn off lighting system circuit breaker #19 on the Power Distribution Panel. Remove the access panel and the connector at the test switch and lamp. Label and disconnect the wires connected to the battery/charger. Remove the hardware and battery/charger from the fixture.

Install the replacement battery/charger, lamp and test switch. Connect wires, wire nuts and connector to the test switch and lamp. Attach access plate and tighten machine screw.

END OF WORK PACKAGE

**CHAPTER 5**

**DIRECT SUPPORT MAINTENANCE PROCEDURES**



THIS PAGE INTENTIONALLY LEFT BLANK

---

**CONTAINERIZED KITCHEN (CK)  
DIRECT SUPPORT MAINTENANCE PROCEDURES**

---

0027 00

**COOK CENTER**

**THIS WORK PACKAGE COVERS:**

Inspect, Repair

**INITIAL SETUP**

Kitchen set up, cook center not operating

**Maintenance Level**

Direct Support

**Tools and Special Tools**

Tool Kit, General Mechanic's (WP 0052 00, Table 1, Item 1)

Shop Equipment, Welding (WP 0052 00, Table 1, Item 2)

---

**GENERAL**

This procedure contains information and instructions to keep the cook center in good working order by inspecting and repairing its metal components and subassemblies.

**INSPECT**

Inspect the following cook center assemblies and components for bent or cracked sheet metal, cracked welds, and loose or missing rivets:

- Base assembly
- Griddle assembly (griddle top and splash guards)
- Steam table and adapter top
- Cook pot cradle adapters (4)
- Base rack
- Burner rack
- Cook pot cradles (2)
- Exhaust hood and grease filters

**REPAIR**

Perform welding operations as described in TM 9-237, Operator's Manual: Welding Theory and Application.

Replace loose or missing rivets and perform sheet metal repair as described in TM 9-510, Metal Body Repair and Related Operations.

END OF WORK PACKAGE

THIS PAGE INTENTIONALLY LEFT BLANK

---

**CONTAINERIZED KITCHEN (CK)  
DIRECT SUPPORT MAINTENANCE PROCEDURES**

---

0028 00

**DUAL OVEN ASSEMBLY**

**THIS WORK PACKAGE COVERS:**

Inspect, Repair

**INITIAL SETUP**

Ovens shut down and cool

**Maintenance Level**

Direct Support

**Tools and Special Tools**

Tool Kit, General Mechanic's (WP 0052 00, Table 1, Item 1)

Shop Equipment, Welding (WP 0052 00, Table 1, Item 2)

---

**GENERAL**

This procedure contains information and instructions to keep the dual oven assembly in good working order by inspecting and repairing its metal components and subassemblies.

**INSPECT**

Inspect the following dual oven assembly components for bent or cracked sheet metal, cracked welds, and loose or missing rivets:

- Oven base assembly
- Oven fan assembly
- Oven racks

**REPAIR**

Perform welding operations as described in TM 9-237, Operator's Manual: Welding Theory and Application.

Replace loose or missing rivets and perform sheet metal repair as described in TM 9-510, Metal Body Repair and Related Operations.

END OF WORK PACKAGE

THIS PAGE INTENTIONALLY LEFT BLANK

---

**CONTAINERIZED KITCHEN (CK)  
DIRECT SUPPORT MAINTENANCE PROCEDURES**

---

0029 00

**TRAY PACK HEATER**

**THIS WORK PACKAGE COVERS:**

Inspect, Repair

**INITIAL SETUP**

Tray Pack Heater shut down, cool, drained

**Maintenance Level**

Direct Support

**Tools and Special Tools**

Tool Kit, General Mechanic's (WP 0052 00, Table 1, Item 1)

Shop Equipment, Welding (WP 0052 00, Table 1, Item 2)

---

**GENERAL**

This procedure contains information and instructions to keep the tray pack heater in good working order by inspecting and repairing its metal components and subassemblies.

**INSPECT**

Inspect the following tray pack heater components for bent or cracked sheet metal, cracked welds, and loose or missing rivets:

- Tray pack heater
- Heater base assembly
- Heater fan assembly

**REPAIR**

Perform welding operations as described in TM 9-237, Operator's Manual: Welding Theory and Application.

Replace loose or missing rivets and perform sheet metal repair as described in TM 9-510, Metal Body Repair and Related Operations.

END OF WORK PACKAGE

THIS PAGE INTENTIONALLY LEFT BLANK

---

**CONTAINERIZED KITCHEN (CK)  
DIRECT SUPPORT MAINTENANCE PROCEDURES**

---

0030 00

**SHELTER ASSEMBLY/MECHANICAL ROOM**

**THIS WORK PACKAGE COVERS:**

Inspect, Repair

**INITIAL SETUP**

CK set up

Air conditioner removed (for air conditioner repair)

**Maintenance Level**

Direct Support

**Tools and Special Tools**

Tool Kit, General Mechanic's (WP 0052 00, Table 1, Item 1)

Shop Equipment, Welding (WP 0052 00, Table 1, Item 2)

---

**GENERAL**

This procedure contains information and instructions to keep the shelter assembly and mechanical room in good working order by inspecting and repairing its components and subassemblies.

**INSPECT**

Inspect the following shelter assembly components for bent or cracked sheet metal, cracked welds, and loose or missing rivets:

- Stairs
- Platform
- Railings

**REPAIR**

**Shelter Assembly:** Perform welding operations as described in TM 9-237, Operator's Manual: Welding Theory and Application.

Replace loose or missing rivets and perform sheet metal repair as described in TM 9-510, Metal Body Repair and Related Operations.

**Air Conditioner:**

**Remove and Replace Evaporator Blower Motor:** Remove the air conditioner top cover (see Figure 1). Label and disconnect the evaporator blower motor wiring in the wire box. Slide the wiring harness through the side wall. Remove the hardware from the side panel and remove the evaporator blower assembly from the air conditioner.

Remove the four screws from the assembly cover and the three screws from the motor mounting bracket. Remove the blower motor from the assembly cover. Remove the blower wheel from the motor shaft.



---

**CONTAINERIZED KITCHEN (CK)  
DIRECT SUPPORT MAINTENANCE PROCEDURES**

---

0030 00

Assemble the blower wheel to the shaft of the replacement blower motor. Tighten the set screw on the flat of the shaft. Assemble the motor mount onto the assembly cover. Tighten nuts. Ensure the blower wheel rotates freely without interference. Attach the ground wire between screw head and washer. Install the blower motor assembly into the air conditioner using the retained hardware. Reconnect the blower motor wiring in the wire box. Ensure the cable assembly is secure and will not contact any moving parts. Reinstall the top cover.

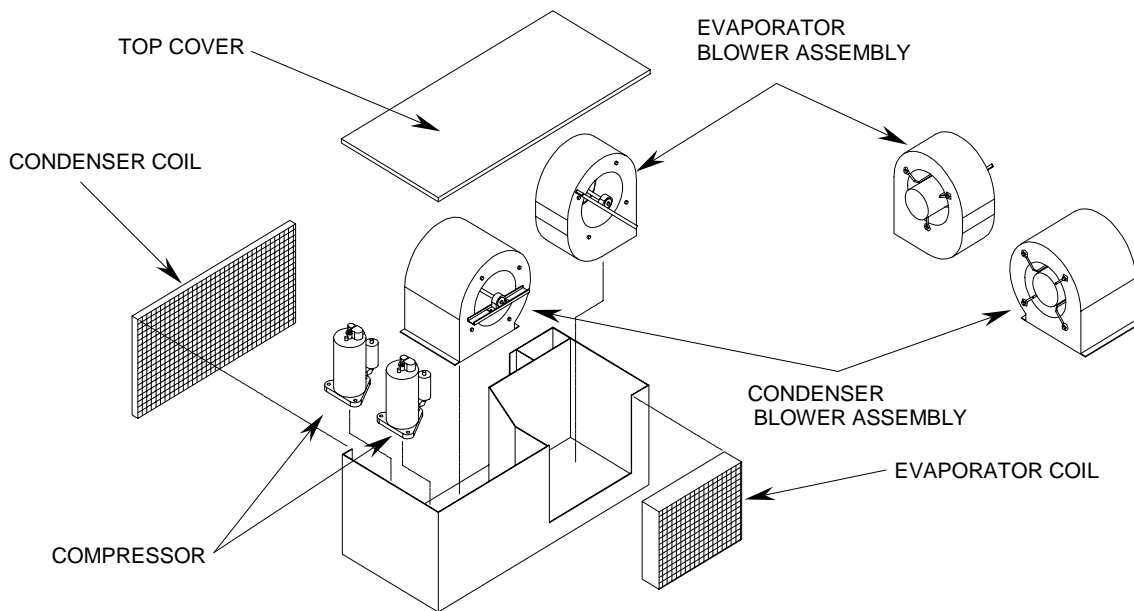

Figure 1. Air Conditioner Repair.

**Remove and Replace Condenser Blower Motor:** Remove the air conditioner top cover (see Figure 1). Remove the six nuts that attach the blower motor assembly to the side panel. Label and disconnect the condenser blower motor wiring. Remove the blower motor assembly from the air conditioner.

Remove the four screws from the assembly cover and the three screws from the motor mounting bracket. Remove the blower motor from the assembly cover. Remove the blower wheel from the motor shaft.

Assemble the blower wheel to the shaft of the replacement blower motor. Tighten the set screw on the flat of the shaft. Assemble the motor mount onto the assembly cover. Tighten nuts.

Ensure the blower wheel rotates freely without interference. Attach the ground wire between screw head and washer. Install the blower motor assembly into the air conditioner using the retained hardware. Reconnect the blower motor wiring. Ensure the cable assembly is secure and will not contact any moving parts. Reinstall the top cover.

END OF WORK PACKAGE

**CHAPTER 6**  
**SUPPORTING INFORMATION**

THIS PAGE INTENTIONALLY LEFT BLANK

**CONTAINERIZED KITCHEN (CK)  
REFERENCES**

0031 00

**SCOPE**

This work package lists field manuals, forms, technical manuals, pamphlets and miscellaneous publications that are referenced in this manual or are otherwise applicable to the operation and maintenance of the CK.

**FIELD MANUALS**

Basic Doctrine for Army Field Feeding and Class I Operations Management.....FM 10-23  
 First Aid for Soldiers.....FM 21-11  
 Theater of Operations Electrical Systems .....FM 5-424  
 Basic Cold Weather Manual.....FM 31-70  
 Chemical and Biological Contamination Avoidance..... FM 3-3  
 NBC Protection ..... FM 3-4  
 NBC Decontamination..... FM 3-5

**FORMS**

Equipment Control Record..... DA Form 2408-9  
 Equipment Inspection and Maintenance Worksheet.....DA Form 2404  
 Hand Receipt .....DA Form 2062  
 Product Quality Deficiency Report..... SF 368  
 Recommended Changes to Publications and Blank Forms .....DA Form 2028  
 Recommended Changes to Equipment Technical Publications..... DA Form 2028-2  
 Transportation Discrepancy Report..... SF 361

**TECHNICAL MANUALS**

Destruction of Army Equipment to Prevent Enemy Use  
 (Mobility Equipment Command) ..... TM 750-244-3  
 Administrative Storage of Equipment ..... TM 740-90-1  
 Preservation, Packaging, and Packing of Military Supplies and Equipment..... TM 38-230-2  
 Welding Theory and Application..... TM 9-237  
 Metal Body Repair and Related Operation ..... TM 9-510  
 Operator's, Unit and Direct Support Maintenance Manual Including Repair Parts &  
 Special Tools List for Modern Burner Unit.....TM 10-7310-281-13&P  
 Operator's Manual for Generator Set, Skid Mounted, Tactical Quiet ..... TM 9-6115-642-10  
 Unit, Direct Support and General Support Maintenance Manual for  
 Generator Set, Skid Mounted, Tactical Quiet ..... TM 9-6115-642-24  
 Operator's, Organizational, Direct Support, and General Support Maintenance  
 (Including Repair Parts and Special Tools List) for Chassis,  
 Containerized Kitchen Trailer: 7½ Ton, 4-Wheel XCK2000 ..... TM 9-2330-328-14&P

---

**CONTAINERIZED KITCHEN (CK)  
REFERENCES**

---

**0031 00**

**PAMPHLETS**

Functional User's Manual for the Army

Maintenance Management System (TAMMS) ..... DA PAM 738-750

**MISCELLANEOUS PUBLICATIONS**

Occupational and Environmental Health Food Service..... TB MED 530

Lubrication Order .....LO 9-6115-642-12

Common Table of Allowances, Expendable/Durable Items .....CTA 50-970

Common Table of Allowances, Army Medical Department

Expendable/Durable Items .....CTA 8-100

---

**CONTAINERIZED KITCHEN (CK)  
MAINTENANCE ALLOCATION CHART (MAC)**

---

0032 00

**INTRODUCTION**

This Work Package provides the Maintenance Allocation Chart (MAC) for the CK, excluding the government-furnished equipment (GFE). Refer to TM 10-7310-281-13&P for the MAC and other maintenance information for the MBU. Refer to TM 9-6115-642-24 for the MAC and other maintenance information for the generator. Refer to TM 9-2330-326-14&P for the MAC and other maintenance information for the trailer (if applicable).

**The Army Maintenance System MAC**

This introduction provides a general explanation of all maintenance and repair functions authorized at various maintenance levels under the standard Army Maintenance System concept.

The MAC (immediately following this introduction) designates overall authority and responsibility for the performance of maintenance functions on the identified end item or component. The application of the maintenance functions to the end item or component shall be consistent with the capacities and capabilities of the designated maintenance levels, which are shown on the MAC in column (4) as:

Unit – includes two subcolumns, C (operator/crew) and O (unit) maintenance.

Direct Support – includes an F subcolumn.

General Support – includes an H subcolumn.

Depot – includes a D subcolumn.

The tools and test equipment requirements (immediately following the MAC) list the tools and test equipment (both special tools and common tool sets) required for each maintenance function as referenced from the MAC.

The remarks (immediately following the tools and test equipment requirements) contain supplemental instructions and explanatory notes for a particular maintenance function.

**Maintenance Functions**

Maintenance functions are limited to and defined as follows:

1. Inspect. To determine the serviceability of an item by comparing its physical, mechanical, and/or electrical characteristics with established standards through examination (e.g., by sight, sound, or feel). This includes scheduled inspection and gagings and evaluation of cannon tubes.
2. Test. To verify serviceability by measuring the mechanical, pneumatic, hydraulic, or electrical characteristics of an item and comparing those characteristics with prescribed standards on a scheduled basis (e.g., load testing of lift devices and hydrostatic testing of pressure hoses).

---

**CONTAINERIZED KITCHEN (CK)  
MAINTENANCE ALLOCATION CHART (MAC)**

---

0032 00

3. Service. Operations required periodically to keep an item in proper operating condition; e.g., to clean (includes decontaminate, when required), to preserve, to drain, to paint, or to replenish fuel, lubricants, chemical fluids, or gases. This includes scheduled exercising and purging of recoil mechanisms.
4. Adjust. To maintain or regulate, within prescribed limits, by bringing into proper position, or by setting the operating characteristics to specified parameters.
5. Align. To adjust specified variable elements of an item to bring about optimum or desired performance.
6. Calibrate. To determine and cause corrections to be made or to be adjusted on instruments of test, measuring, and diagnostic equipment used in precision measurement. Consists of comparisons of two instruments, one of which is a certified standard of known accuracy, to detect and adjust any discrepancy in the accuracy of the instrument being compared.
7. Remove/Install. To remove and install the same item when required to perform service or other maintenance functions. Install may be the act of emplacing, seating, or fixing into position a spare, repair part, or module (component or assembly) in a manner to allow the proper functioning of an equipment or system.
8. Replace. To remove an unserviceable item and install a serviceable counterpart in its place. "Replace" is authorized by the MAC and assigned maintenance level is shown as the third position code of the Source, Maintenance and Recoverability (SMR) code.
9. Repair. The application of maintenance services, including fault location and troubleshooting, removal and installation, disassembly and assembly procedures, and maintenance actions to identify troubles and restore serviceability to an item by correcting specific damage, fault, malfunction, or failure in a part, subassembly, module (component or assembly), end item, or system.

**NOTE**

**The following definitions are applicable to the "repair" maintenance function:**

**Services – Inspect, test, service, adjust, align, calibrate, and/or replace.**

**Fault location/troubleshooting – The process of investigating and detecting the cause of equipment malfunctioning; the act of isolating a fault within a system or Unit Under Test (UUT).**

**Disassembly/assembly – The step-by-step breakdown (taking apart) of a spare/functional group coded item to the level of its least component, that is assigned an SMR code for the level of maintenance under consideration (i.e., identified as maintenance significant).**

**Actions – Welding, grinding, riveting, straightening, facing, machining, and/or resurfacing.**

---

**CONTAINERIZED KITCHEN (CK)  
MAINTENANCE ALLOCATION CHART (MAC)**

---

0032 00

10. Overhaul. That maintenance effort (service/action) prescribed to restore an item to a completely serviceable/operational condition as required by maintenance standards in appropriate technical publications. Overhaul is normally the highest degree of maintenance performed by the Army. Overhaul does not normally return an item to like new condition.
11. Rebuild. Consists of those services/actions necessary for the restoration of unserviceable equipment to a like new condition in accordance with original manufacturing standards. Rebuild is the highest degree of materiel maintenance applied to Army equipment. The rebuild operation includes the act of returning to zero those age measurements (e.g., hours/miles) considered in classifying Army equipment/components.

**Explanation of Columns in the MAC**

Column (1) – Group Number. Column (1) lists Functional Group Code (FGC) numbers, the purpose of which is to identify maintenance significant components, assemblies, subassemblies, and modules with the Next Higher Assembly (NHA).

Column (2) – Component/Assembly. Column (2) contains the item names of components, assemblies, subassemblies, and modules for which maintenance is authorized.

Column (3) – Maintenance Function. Column (3) lists the functions to be performed on the item listed in column (2). (For a detailed explanation of these functions refer to “Maintenance Functions” outlined above).

Column (4) – Maintenance Level. Column (4) specifies each level of maintenance authorized to perform each function listed in column (3), by indicating work time required (expressed as manhours in whole hours or decimals) in the appropriate subcolumn. This work time figure represents the active time required to perform that maintenance function at the indicated level of maintenance. If the number or complexity of the tasks within the listed maintenance function varies at different maintenance levels, appropriate work time figures are to be shown for each level. The work time figure represents the average time required to restore an item (assembly, subassembly, component, module, end item, or system) to a serviceable condition under typical field operating conditions. This time includes preparation time (including any necessary disassembly/assembly time), troubleshooting/fault location time, and quality assurance time in addition to the time required to perform the specific tasks identified for the maintenance functions authorized in the MAC. The symbol designations for the various maintenance levels are as follows:

C – Operator or crew maintenance

O – Unit maintenance

F – Direct support maintenance

L – Specialized repair activity (SRA)

H – General support maintenance

D – Depot maintenance



---

**CONTAINERIZED KITCHEN (CK)  
MAINTENANCE ALLOCATION CHART (MAC)**

---

**0032 00**

**NOTE**

The “L” maintenance level is not included in column (4) of the MAC. Functions to this level are identified by a work time figure in the “H” column of column (4), and an associated reference code is used in the REMARKS column (6). This code is keyed to the remarks and the SRA complete repair application is explained there.

Column (5) – Tools and Equipment Reference Code. Column (5) specifies, by code, those common tool sets (not individual tools), common Test, Measurement and Diagnostic Equipment (TMDE), and special tools, special TMDE and special support equipment required to perform the designated function. Codes are keyed to the entries in the tools and test equipment table.

Column (6) – Remarks Code. When applicable, this column contains a letter code, in alphabetical order, which is keyed to the remarks table entries.

**Explanation of Columns in the Tools and Test Equipment Requirements**

Column (1) – Tool or Test Equipment Reference Code. The tool or test equipment reference code correlates with a code used in column (5) of the MAC.

Column (2) – Maintenance Level. The lowest level of maintenance authorized to use the tool or test equipment.

Column (3) – Nomenclature. Name or identification of the tool or test equipment.

Column (4) – National Stock Number (NSN). The NSN of the tool or test equipment.

Column (5) – Tool Number. The manufacturer’s part number, model number, or type number.

**Explanation of Columns in the Remarks**

Column (1) – Remarks Code. The code recorded in column (6) of the MAC.

Column (2) – Remarks. This column lists information pertinent to the maintenance function being performed as indicated in the MAC.

**CONTAINERIZED KITCHEN (CK)  
MAINTENANCE ALLOCATION CHART (MAC)**

**0032 00**

**MAINTENANCE ALLOCATION CHART FOR CK**

**Table 1. MAC for CK**

(1) GROUP NO.	(2) COMPONENT/ ASSEMBLY	(3) MAINTENANCE FUNCTION	(4) MAINTENANCE LEVEL					(5) TOOLS AND EQUIPMENT REFERENCE CODE	(6) REMARKS CODE
			UNIT		DS	GS	DEPOT		
			C	O	F	H	D		
00	CONTAINERIZED KITCHEN							1, 2	
01	SHELTER								
0101	TENTAGE	INSPECT REPAIR REPLACE	0.3	0.5 8.0					Q
0102	CONTAINER	INSPECT REPAIR	0.3	0.5					Z
010201	WINCH/CABLE ASSEMBLY	INSPECT REPLACE	0.1	0.1 1.0					R
010202	STAIRS/RAILINGS	INSPECT REPAIR	0.2	0.3	0.5				A, V
010203	AWNING ASSEMBLY	INSPECT REPAIR	0.1	0.5					Q
010204	JACKS	INSPECT REPAIR	0.2	0.5					W
010205	EXTERIOR DRAIN HOSE	INSPECT REPAIR	0.1	0.2					B
02	MECHANICAL ROOM								
0201	EXHAUST PIPE ASSEMBLY	INSPECT REPAIR	0.1		0.5				V
0202	EXHAUST DUCTS (CLOTH)	INSPECT REPAIR	0.1	0.3					Q
0203	ENVIRONMENTAL CONTROL UNIT								
020301	AIR CONDITIONERS	INSPECT REPAIR REPLACE	0.1	0.3 0.6	2.0				
020302	ECU CONTROL BOX	INSPECT REPAIR	0.1	0.3					
020303	ECU CONTROL SWITCH ASSEMBLY	INSPECT REPAIR	0.1	0.1 0.5					
0204	INTAKE FAN	INSPECT REPLACE	0.1	1.0					
0205	EXHAUST FAN	INSPECT REPLACE	0.1	1.0					

**CONTAINERIZED KITCHEN (CK)  
MAINTENANCE ALLOCATION CHART (MAC)**

**0032 00**

**Table 1. MAC for CK – Continued.**

(1) GROUP NO.	(2) COMPONENT/ ASSEMBLY	(3) MAINTENANCE FUNCTION	(4) MAINTENANCE LEVEL					(5) TOOLS AND EQUIPMENT REFERENCE CODE	(6) REMARKS CODE
			UNIT		DS	GS	DEPOT		
			C	O	F	H	D		
03	COOK CENTER								
0301	GRIDDLE ASSEMBLY	INSPECT REPAIR	0.1	0.4	0.6			A, V	
0302	STEAM TABLE & ADAPTER TOP	INSPECT REPAIR	0.1	0.5	1.0			A, V	
0303	COOK POT CRADLE ADAPTER	INSPECT REPAIR	0.1	0.3	0.5			A, U, V	
0304	COOK POT CRADLE ASSEMBLY								
030401	BASE RACK	INSPECT REPAIR	0.1	0.2	0.5			A, V	
030402	BURNER RACK	INSPECT REPAIR	0.1	0.2	0.5			A, V	
030403	COOK POT CRADLE	INSPECT REPAIR	0.1	0.2	0.5			A, U, V	
0305	FUEL LINE ASSEMBLY	INSPECT REPLACE	0.1	0.5				A, T	
0306	24 VDC POWER CABLE ASSEMBLY	INSPECT REPAIR REPLACE	0.1	0.3 0.5				C	
0307	BASE ASSEMBLY	INSPECT REPAIR	0.2	0.4	1.2			A, H	
04	EXHAUST HOOD	INSPECT REPAIR	0.1	0.5	0.5			A, U, V	
05	DUAL OVEN ASSEMBLY								
0501	OVENS	INSPECT REPAIR	0.1	0.3	0.5			A, U, V	
0502	OVEN FAN ASSEMBLY	INSPECT REPAIR	0.1	0.2	0.3			A, E, U	

**CONTAINERIZED KITCHEN (CK)  
MAINTENANCE ALLOCATION CHART (MAC)**

**0032 00**

**Table 1. MAC for CK – Continued.**

(1) GROUP NO.	(2) COMPONENT/ ASSEMBLY	(3) MAINTENANCE FUNCTION	(4) MAINTENANCE LEVEL					(5) TOOLS AND EQUIPMENT REFERENCE CODE	(6) REMARKS CODE
			UNIT		DS	GS	DEPOT		
			C	O	F	H	D		
0503	FUEL LINE ASSEMBLY	INSPECT REPLACE	0.1	0.5				T	
0504	24 VDC POWER CABLE ASSEMBLY	INSPECT REPAIR REPLACE	0.1	0.3 0.5				C	
0505	OVEN BASE ASSEMBLY	INSPECT REPAIR	0.1	0.2 0.3	0.5			A, V	
06	MOBILE WARMING CABINET	INSPECT REPAIR REPLACE	0.1	0.5 0.5				A, D, X	
07	REFRIGERATORS	INSPECT REPAIR	0.1	0.5				A, D	
08	TRAY PACK HEATER	INSPECT REPAIR	0.2	0.3 0.5	0.5			A, G, U, V	
0801	HEATER FAN ASSEMBLY	INSPECT REPAIR	0.1	0.4	0.4			A, C, U	
09	HAND SINK ASSEMBLY								
0901	CABINET ASSEMBLY	INSPECT REPAIR	0.1	0.4				A, I	
0902	WATER HEATER	INSPECT REPLACE	0.1	0.7				J	
0903	WATER PUMP	INSPECT REPLACE	0.1	0.5				K	

**CONTAINERIZED KITCHEN (CK)  
MAINTENANCE ALLOCATION CHART (MAC)**

**0032 00**

**Table 1. MAC for CK – Continued.**

(1) GROUP NO.	(2) COMPONENT/ ASSEMBLY	(3) MAINTENANCE FUNCTION	(4) MAINTENANCE LEVEL					(5) TOOLS AND EQUIPMENT REFERENCE CODE	(6) REMARKS CODE
			UNIT		DS	GS	DEPOT		
			C	O	F	H	D		
0904	SINK	INSPECT REPLACE	0.1	0.2 0.5				S	
090401	FAUCET	INSPECT REPAIR REPLACE	0.1	0.5 0.5				L	
0905	WATER SUPPLY HOSES	INSPECT REPAIR	0.1	0.2				B	
0906	INTERIOR DRAIN HOSE	INSPECT REPAIR	0.1	0.2				B	
10	MOBILE STORAGE CABINETS	INSPECT REPAIR	0.1	0.5	1.0			A, V	
11	PREP/SERVING TABLES	INSPECT REPAIR	0.1 0.3					A	
12	ELECTRICAL SYSTEM								
1201	POWER ENTRANCE PANEL	INSPECT REPAIR	0.1	0.3 0.7				Y	
1202	POWER DISTRIBUTION PANEL	INSPECT REPLACE	0.1	0.3 0.7				N	
1203	MAIN CONTROL PANEL	INSPECT REPLACE	0.1	0.3 0.3				C, M	
1204	APPLIANCE CONTROL BOX	INSPECT REPAIR REPLACE	0.1	0.3 0.5 0.5				C, M, N	
1205	MBU POWER SWITCH ASSEMBLY	INSPECT REPLACE	0.1	0.3 0.5				C, M	
1206	CEILING LIGHTS (FIXED)	INSPECT REPAIR REPLACE	0.1	0.3 0.5 0.5				A, H	
1207	CEILING LIGHTS (REMOVABLE)	INSPECT REPAIR REPLACE	0.1	0.3 0.5 0.5				A, H	

**CONTAINERIZED KITCHEN (CK)  
MAINTENANCE ALLOCATION CHART (MAC)**

0032 00

**TOOLS AND TEST EQUIPMENT FOR CK**

**Table 2. Tools and Test Equipment for CK.**

TOOL OR TEST EQUIPMENT REFERENCE CODE	MAINTENANCE LEVEL	NOMENCLATURE	NATIONAL STOCK NUMBER	TOOL NUMBER
1	O	TOOL KIT, GENERAL MECHANIC'S (GMTK)	5180-01-454-3787	
2	F	SHOP EQUIPMENT, WELDING	4940-01-090-1231	

**REMARKS FOR CK**

**Table 3. Remarks for CK.**

REMARKS CODE	REMARKS
A	General hardware repair at O level (tighten/replace hardware, straighten piece parts)
B	Washer replacement at O level
C	Cable/connector repair, replacement at O level
D	Caster replacement, connector repair, door gasket replacement at O level
E	Power cord replacement, motor replacement at O level
F	Replacement of power cord, module, caster, temperature controller at O level
G	Drain cock replacement at O level
H	Ballast replacement, wiring repair at O level
I	Replacement of caster, towel dispenser, soap dispenser at O level
J	Replacement of power cord, water heater at O level
K	Replacement of power cord, water pump at O level
L	Hot, cold faucet washer replacement, faucet replacement at O level
M	Switch replacement at O level
N	Circuit breaker replacement at O level
O	PC board replacement at O level
P	Converter replacement at O level
Q	Fabric repair at O level
R	Winch, cable replacement at O level
S	Drain repair, sink replacement at O level
T	Fuel line section replacement at O level
U	Rivet repair at DS level
V	Welding repair at DS level
W	Shear pin replacement at O level
X	Temperature control module replacement at O level
Y	Power connector, ground terminal, contactor replacement at O level
Z	Cam-lock replacement at O level

THIS PAGE INTENTIONALLY LEFT BLANK

---

**CONTAINERIZED KITCHEN (CK)  
INTRODUCTION TO REPAIR PARTS & SPECIAL TOOLS LIST**

---

**0033 00**

**SCOPE**

This Repair Parts & Special Tools List (RPSTL) lists and authorizes spares and repair parts; special tools; special test, measurement, and diagnostic equipment (TMDE); and other special support equipment required for performance of Operator, Unit, and Direct Support maintenance of the Containerized Kitchen (CK). It authorizes the requisitioning, issue, and disposition of spares, repair parts, and special tools as indicated by the source, maintenance, and recoverability (SMR) codes.

**GENERAL**

In addition to the Introduction work package, this RPSTL is divided into the following work packages:

1. Repair Parts List Work Packages. Work packages containing lists of spares and repair parts authorized by this RPSTL for use in the performance of maintenance. These work packages also include parts which must be removed for replacement of the authorized parts. Parts lists are composed of functional groups in ascending alphanumeric sequence, with the parts in each group listed in ascending figure and item number sequence. Sending units, brackets, filters, and bolts are listed with the component they mount on. Bulk materials are listed by item name in FIG. BULK at the end of the work packages. Repair parts kits are listed separately in their own functional group and work package. Repair parts for reparable special tools are also listed in a separate work package. Items listed are shown on the associated illustrations.
2. Special Tools List Work Packages. Work packages containing lists of special tools, special TMDE, and special support equipment authorized by this RPSTL (as indicated by Basis of Issue (BOI) information in the DESCRIPTION AND USABLE ON CODE (UOC) column). Tools that are components of common tool sets and/or Class VII are not listed.
3. Cross-Reference Indexes Work Packages. There are two cross-reference indexes work packages in this RPSTL: the National Stock Number (NSN) Index work package and the Part Number (P/N) Index work package. The National Stock Number Index work package refers you to the figure and item number. The Part Number Index work package refers you to the figure and item number.

**EXPLANATION OF COLUMNS IN THE REPAIR PARTS LIST AND SPECIAL TOOLS LIST WORK PACKAGES**

**ITEM NO.** (Column (1)). Indicates the number used to identify items called out in the illustration.

**SMR CODE** (Column (2)). The SMR code containing supply/requisitioning information, maintenance level authorization criteria, and disposition instructions, as shown in the following breakout:



**CONTAINERIZED KITCHEN (CK)  
INTRODUCTION TO REPAIR PARTS & SPECIAL TOOLS LIST**

**0033 00**

<u>Source Code</u>	<u>Maintenance Code</u>	<u>Recoverability Code</u>
XX	XX	X
1 <sup>st</sup> two positions: How to get an item.	3 <sup>rd</sup> position: Who can install, replace, or use the item	4 <sup>th</sup> position: Who can do complete repair* on the item
		5 <sup>th</sup> position: Who determines disposition action on unserviceable items.

\*Complete Repair: Maintenance capacity, capability, and authority to perform all corrective maintenance tasks of the "Repair" function in a use/user environment in order to restore serviceability to a failed item.

Source Code. The source code tells you how you get an item needed for maintenance, repair, or overhaul of an end item/equipment. Explanations of source codes follow:

**Source Code**

**Application/Explanation**

PA  
PB  
PC  
PD  
PE  
PF  
PG

Stock items; use the applicable NSN to requisition/request items with these source codes. They are authorized to the level indicated by the code entered in the 3<sup>rd</sup> position of the SMR code.

**NOTE**

Items coded PC are subject to deterioration.

KD  
KF  
KB

Items with these codes are not to be requested/requisitioned individually. They are part of a kit which is authorized to the maintenance level indicated in the 3<sup>rd</sup> position of the SMR code. The complete kit must be requisitioned and applied.

MO – Made at unit/AVUM level  
MF – Made at DS/AVIM level  
MH – Made at GS level  
ML – Made at SRA  
MD – Made at depot

Items with these codes are not to be requisitioned/requested individually. They must be made from bulk material which is identified by the P/N in the DESCRIPTION AND USABLE ON CODE (UOC) column and listed in the bulk material group work package of the RPSTL. If the item is authorized to you by the 3<sup>rd</sup> position code of the SMR code, but the source code indicates it is made at higher level, order the item from the higher level of maintenance.

---

**CONTAINERIZED KITCHEN (CK)  
INTRODUCTION TO REPAIR PARTS & SPECIAL TOOLS LIST**

---

**0033 00**

**Source Code**

**Application/Explanation**

AO – Assembled by unit/AVUM level  
 AF – Assembled by DS/AVIM level  
 AH – Assembled by GS level  
 AL – Assembled by SFA  
 AD – Assembled by depot

Items with these codes are not to be requested/requisitioned individually. The parts that make up the assembled item must be requisitioned or fabricated and assembled at the level of maintenance indicated by the source code. If the 3<sup>rd</sup> position of the SMR code authorizes you to replace the item, but the source code indicates the item is assembled at a higher level, order the item from the higher level of maintenance.

XA

Do not requisition an “XA” coded item. Order the next higher assembly. (Refer to NOTE below).

XB

If an item is not available from salvage, order it using the CAGEC and P/N.

XC

Installation drawings, diagrams, instruction sheets, field service drawings; identified by manufacturer’s P/N.

XD

Item is not stocked. Order an XD-coded item through normal supply channels using the CAGEC and P/N given, if no NSN is available.

**NOTE**

**Cannibalization or controlled exchange, when authorized, may be used as a source of supply for items with the above source codes except for those items source coded “XA” or those aircraft support items restricted by requirements of AR 750-1.**

Maintenance Code. Maintenance codes tell you the level(s) of maintenance authorized to use and repair support items. The maintenance codes are entered in the third and fourth positions of the SMR code as follows:

Third Position. The maintenance code entered in the third position tells you the lowest maintenance level authorized to remove, replace, and use an item. The maintenance code entered in the third position will indicate authorization to the following levels of maintenance:

**Maintenance Code**

**Application/Explanation**

C	Crew or operator maintenance done within unit/AVUM maintenance.
O	Unit level/AVUM maintenance can remove, replace, and use the item.
F	Direct support/AVIM maintenance can remove, replace, and use the item.

---

**CONTAINERIZED KITCHEN (CK)  
INTRODUCTION TO REPAIR PARTS & SPECIAL TOOLS LIST**

---

**0033 00**

<u>Source Code</u>	<u>Application/Explanation</u>
H	General support maintenance can remove, replace, and use the item.
L	Specialized repair activity can remove, replace, and use the item.
D	Depot can remove, replace, and use the item.

Fourth Position. The maintenance code entered in the fourth position tells you whether or not the item is to be repaired and identifies the lowest maintenance level with the capability to do complete repair (perform all authorized repair functions).

**NOTE**

**Some limited repair may be done on the item at a lower level of maintenance, if authorized by the Maintenance Allocation Chart (MAC) and SMR codes.**

<u>Maintenance Code</u>	<u>Application/Explanation</u>
O	Unit/AVUM is the lowest level that can do complete repair of the item.
F	Direct support/AVIM is the lowest level that can do complete repair of the item.
H	General support is the lowest level that can do complete repair of the item.
L	Specialized Repair Activity (SRA) is the lowest level that can do complete repair of the item.
D	Depot is the lowest level that can do complete repair of the item.
Z	Nonreparable. No repair is authorized.
B	No repair is authorized. No parts or special tools are authorized for maintenance of "B" coded items. However, the items may be reconditioned by adjusting, lubricating, etc., at the user level.

---

**CONTAINERIZED KITCHEN (CK)  
INTRODUCTION TO REPAIR PARTS & SPECIAL TOOLS LIST**

---

**0033 00**

Recoverability Code. Recoverability codes are assigned to items to indicate the disposition action on unserviceable items. The recoverability code is shown in the fifth position of the SMR code as follows:

<u>Recoverability Code</u>	<u>Application/Explanation</u>
Z	Nonreparable item. When unserviceable, condemn and dispose of the item at the level of maintenance shown in the third position of the SMR code.
O	Reparable item. When uneconomically repairable, condemn and dispose of the item at the unit level.
F	Reparable item. When uneconomically repairable, condemn and dispose of the item at the direct support level.
H	Reparable item. When uneconomically repairable, condemn and dispose of the item at the general support level.
D	Reparable item. When beyond lower level repair capability, return to depot. Condemnation and disposal of item are not authorized below depot level.
L	Reparable item. Condemnation and disposal not authorized below Specialized Repair Activity (SRA).
A	Items requires special handling or condemnation procedures because of specific reasons (such as precious metal content, high dollar value, critical material, or hazardous material). Refer to appropriate manuals/directives for specific instructions.

NSN Column (3)). The NSN for the item is listed in this column.

CAGEC (Column (4)). The Commercial and Government Entity Code (CAGEC) is a five-digit code which is used to identify the manufacturer, distributor, or Government agency/activity that supplies the item.

PART NUMBER (Column (5)). Indicates the primary number used by the manufacturer (individual, company, firm, corporation, or Government activity), which controls the design and characteristics of the item by means of its engineering drawings, specifications, standards, and inspection requirements to identify an item or range of items.

**NOTE**

**When you use an NSN to requisition an item, the item you receive may have a different P/N from the number listed.**

---

**CONTAINERIZED KITCHEN (CK)  
INTRODUCTION TO REPAIR PARTS & SPECIAL TOOLS LIST**

---

**0033 00**

DESCRIPTION AND USABLE ON CODE (UOC) (Column (6)). This column includes the following information:

1. The federal item name, and when required, a minimum description to identify the item.
2. P/Ns of bulk materials are referenced in this column in the line entry to be manufactured or fabricated.
3. Hardness Critical Item (HCI). A support item that provides the equipment with special protection from electromagnetic pulse (EMP) damage during a nuclear attack.
4. The statement END OF FIGURE appears just below the last item description in column (6) for a given figure in both the repair parts list and special tools list work packages.

QTY (Column (7)). The QTY (quantity per figure) column indicates the quantity of the item used in the breakout shown on the illustration/figure, which is prepared for a functional group, subfunctional group, or an assembly. A "V" appearing in this column instead of a quantity indicates that the quantity is variable and quantity may change from application to application.

**EXPLANATION OF CROSS-REFERENCE INDEXES WORK PACKAGES FORMAT AND COLUMNS.**

1. National Stock Number (NSN) Index Work Package.

STOCK NUMBER Column. This column lists the NSN in National Item Identification Number (NIIN) sequence. The NIIN consists of the last nine digits of the NSN. When using this column to locate an item, ignore the first four digits of the NSN. However, the complete NSN should be used when ordering items by stock number.

FIG. Column. This column lists the number of the figure where the item is identified/located. The figures are in numerical order in the repair parts list and special tools list work packages.

ITEM Column. The item number identifies the item associated with the figure listed in the adjacent FIG. Column. This item is also identified by the NSN listed on the same line.

2. Part Number (P/N) Index Work Package. P/Ns in this index are listed in ascending alphanumeric sequence (vertical arrangement of letter and number combinations which places the first letter or digit of each group in order A through Z, followed by the numbers 0 through 9 and each following letter or digit in like order).

PART NUMBER Column. Indicates the P/N assigned to the item.

FIG. Column. This column lists the number of the figure where the item is identified/located in the repair parts list and special tools list work packages.

ITEM Column. The item number is the number assigned to the item as it appears in the figure referenced in the adjacent figure number column.

---

**CONTAINERIZED KITCHEN (CK)  
INTRODUCTION TO REPAIR PARTS & SPECIAL TOOLS LIST**

---

**0033 00**

**SPECIAL INFORMATION**

UOC. The UOC appears in the lower left corner of the Description Column heading. Usable on codes are shown as "UOC: . . ." in the Description Column (justified left) on the first line under the applicable item/nomenclature. Uncoded items are applicable to all models. Identification of the UOCs used in this RPSTL are: Not Applicable.

Fabrication Instructions. Bulk materials required to manufacture items are listed in the bulk material functional group of this RPSTL. Part numbers for bulk material are also referenced in the Description Column of the line item entry for the item to be manufactured/fabricated. Detailed fabrication instructions for items source coded to be manufactured or fabricated are found in: Not Applicable.

Index Numbers. Items which have the word BULK in the figure column will have an index number shown in the item number column. This index number is a cross-reference between the NSN and P/N index work packages and the bulk material list in the repair parts list work package.

Associated Publications. The publication(s) listed below pertain to the Containerized Kitchen:

<u>Publication</u>	<u>Title</u>
TM 10-7310-281-13&P	Operator's, Unit and Direct Support Maintenance Manual Including Repair Parts and Special Tools List for Modern Burner Unit
TM 9-6115-642-10	Operator's Manual, Generator Set, Skid Mounted, Tactical Quiet, 10 KW, 60 and 400 Hz
TM 9-6115-642-24	Unit, Direct Support and General Support Maintenance Manual for Generator Set, Skid Mounted, Tactical Quiet
TM 9-2330-326-14&P	Operator's, Organizational, Direct Support and General Support Maintenance Manual (Including Repair Parts and Special Tools Lists) for Chassis, Trailer

Illustrations List. The illustrations in this RPSTL contain unit and direct support authorized items. The tabular list in the repair parts list work package contains only those parts coded "O" and "F" in the third position of the SMR code, therefore, there may be a break in the item number sequence.

---

**CONTAINERIZED KITCHEN (CK)  
INTRODUCTION TO REPAIR PARTS & SPECIAL TOOLS LIST**

---

**0033 00**

**HOW TO LOCATE REPAIR PARTS**

**1. When NSNs or P/Ns Are Not Known.**

First. Using the table of contents, determine the assembly group to which the item belongs. This is necessary since figures are prepared for assembly groups and subassembly groups, and lists are divided into the same groups.

Second. Find the figure covering the functional group or the subfunctional group to which the item belongs.

Third. Identify the item on the figure and note the number(s).

Fourth. Look in the repair parts list work packages for the figure and item numbers. The NSNs and part numbers are on the same line as the associated item numbers.

**2. When NSN Is Known.**

First. If you have the NSN, look in the STOCK NUMBER column of the NSN index work package. The NSN is arranged in NIIN sequence. Note the figure and item number next to the NSN.

Second. Turn to the figure and locate the item number. Verify that the item is the one you are looking for.

**3. When P/N Is Known.**

First. If you have the P/N and not the NSN, look in the PART NUMBER column of the P/N index work package. Identify the figure and item number.

Second. Look up the item on the figure in the applicable repair parts list work package.

THIS PAGE INTENTIONALLY LEFT BLANK



CONTAINERIZED KITCHEN (CK)  
GROUP 01 SHELTER REPAIR PARTS

0034 00

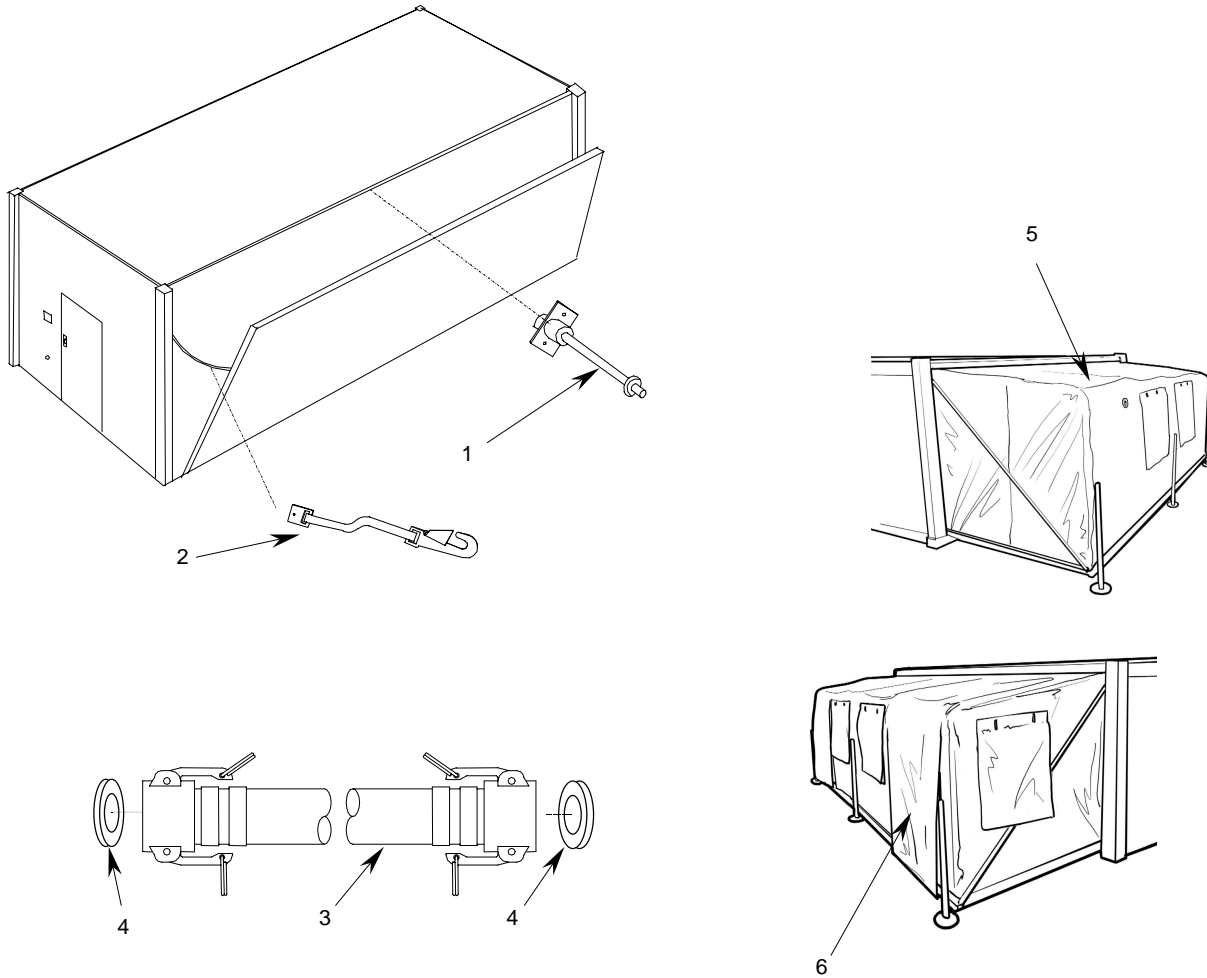

Figure 1. Container.

**CONTAINERIZED KITCHEN (CK)  
GROUP 01 SHELTER REPAIR PARTS**

**0034 00**

(1) ITEM NO.	(2) SMR CODE	(3) NSN	(4) CAGEC	(5) PART NUMBER	(6) DESCRIPTION AND USABLE ON CODE (UOC)	(7) QTY
GROUP 01 SHELTER ASSEMBLY						
FIGURE 1 CONTAINER						
1	PAOZZ		80298	50389344	KICKER, SIDE.....	2
2	PAOZZ		80298	50289214	STRAP, SAFETY.....	2
3	PAOZZ		0U5N7	47011050-1	HOSE ASSEMBLY, EXTERNAL DRAIN.....	1
4	PAOZZ		7S077	B03	. GASKET, BUNA N.....	2
5	PAOZZ		0U5N7	47018028	FABRIC COVER, PREPARATION WING.....	1
6	PAOZZ		80298	60401008	FABRIC COVER, SERVING WING.....	1
END OF FIGURE						

---

CONTAINERIZED KITCHEN (CK)  
GROUP 01 SHELTER REPAIR PARTS

---

0034 00

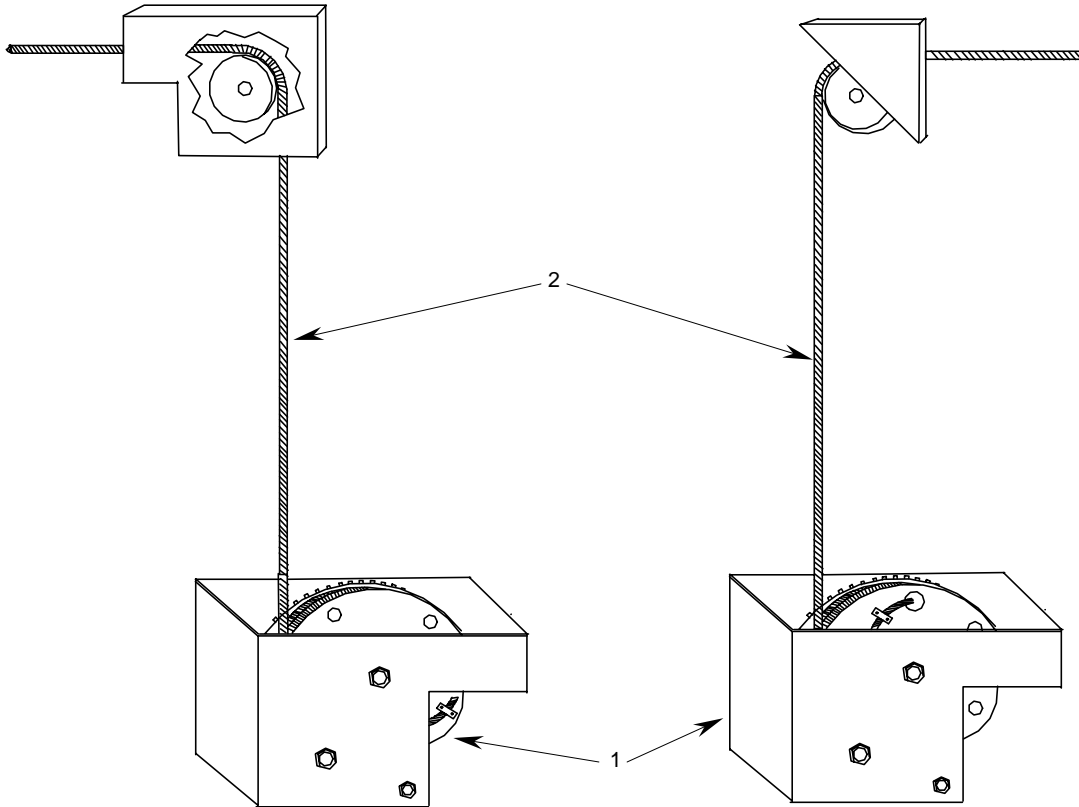

Figure 2. Winch/Cable Assembly.

**CONTAINERIZED KITCHEN (CK)  
GROUP 01 SHELTER REPAIR PARTS**

**0034 00**

(1) ITEM NO.	(2) SMR CODE	(3) NSN	(4) CAGEC	(5) PART NUMBER	(6) DESCRIPTION AND USABLE ON CODE (UOC)	(7) QTY
					GROUP 01 SHELTER ASSEMBLY	
					FIGURE 2 WINCH/CABLE ASSEMBLY	
1	PBOZZ		80298	50389296	ASSEMBLY, WINCH DRUM.....	2
2	PAOZZ		80298	50389297	CABLE, SHELTER .....	2
					END OF FIGURE	

CONTAINERIZED KITCHEN (CK)  
GROUP 01 SHELTER REPAIR PARTS

0034 00

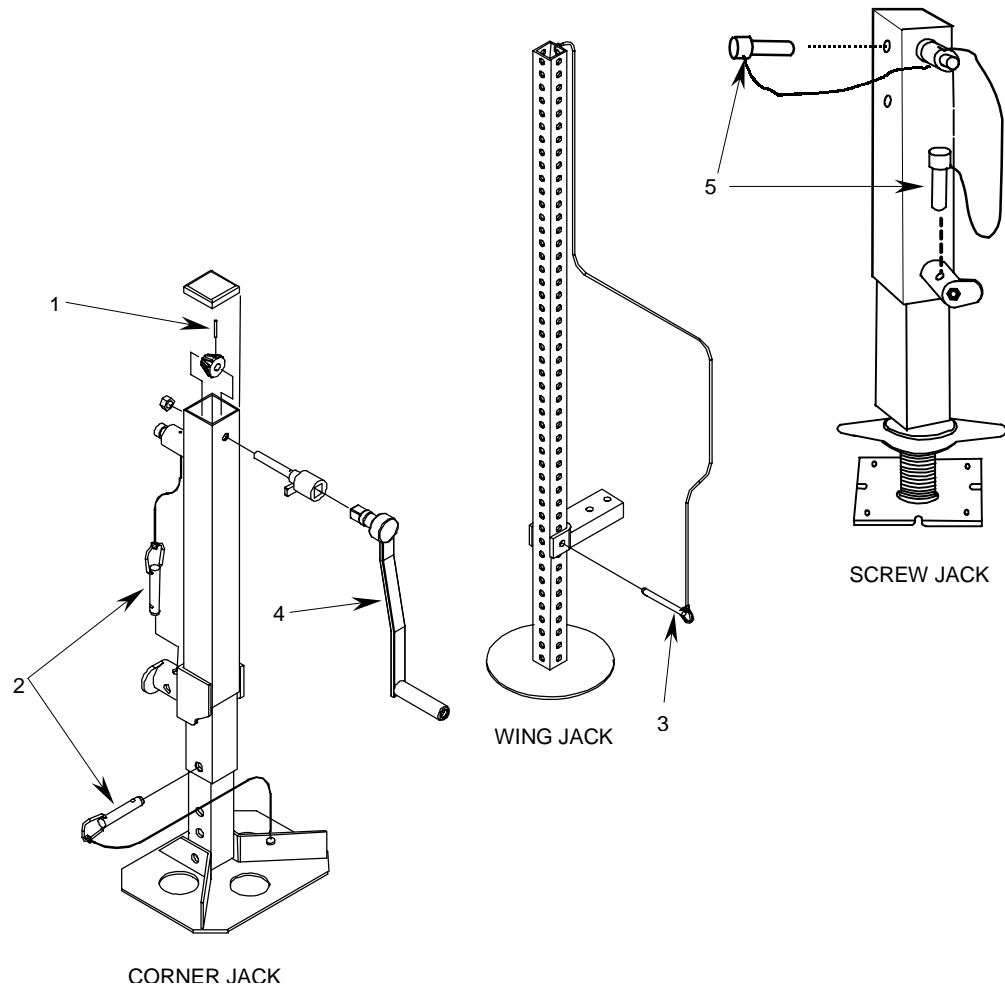

Figure 3. Jacks.

**CONTAINERIZED KITCHEN (CK)  
GROUP 01 SHELTER REPAIR PARTS**

**0034 00**

(1) ITEM NO.	(2) SMR CODE	(3) NSN	(4) CAGEC	(5) PART NUMBER	(6) DESCRIPTION AND USABLE ON CODE (UOC)	(7) QTY
GROUP 01 SHELTER ASSEMBLY						
FIGURE 3 JACKS						
1	PAOZZ		80298	50389341	PIN, SHEAR, CORNER JACK .....	1
2	PAOZZ		80298	50389299	PIN, ASSEMBLY, CORNER JACK .....	2
3	PAOZZ		80298	50389343	PIN, ASSEMBLY, WING JACK .....	1
4	PAOZZ		80298	50389298	HANDLE, JACK/WINCH .....	1
5	PAOZZ		80298	50389299	PIN, ASSEMBLY, SCREW JACK .....	2
END OF FIGURE						

THIS PAGE INTENTIONALLY LEFT BLANK

THIS PAGE INTENTIONALLY LEFT BLANK



---

CONTAINERIZED KITCHEN (CK)  
GROUP 02 MECHANICAL ROOM REPAIR PARTS

---

0035 00

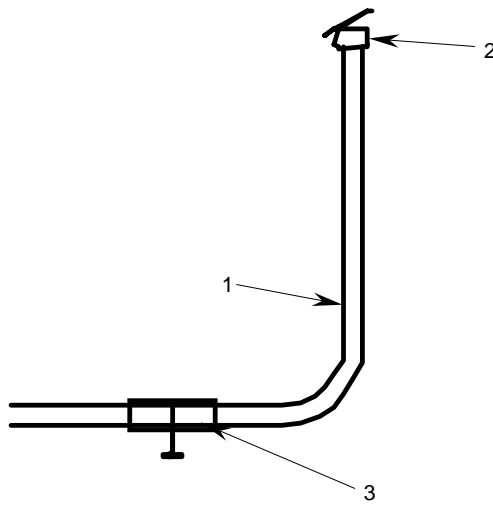

Figure 4. Exhaust Pipe Assembly.

**CONTAINERIZED KITCHEN (CK)  
GROUP 02 MECHANICAL ROOM REPAIR PARTS**

**0035 00**

(1) ITEM NO.	(2) SMR CODE	(3) NSN	(4) CAGEC	(5) PART NUMBER	(6) DESCRIPTION AND USABLE ON CODE (UOC)	(7) QTY
					GROUP 02 MECHANICAL ROOM FIGURE 4 EXHAUST PIPE ASSEMBLY	
1	PAOZZ		0U5N7	47012265	ELBOW, EXHAUST.....	1
2	PAOZZ		0U5N7	A161802	CAP, RAIN.....	1
3	PAOZZ		39428	6815K13	COUPLING, PIPE, QUICK-LOCK.....	1
					END OF FIGURE	

CONTAINERIZED KITCHEN (CK)  
GROUP 02 MECHANICAL ROOM REPAIR PARTS

0035 00

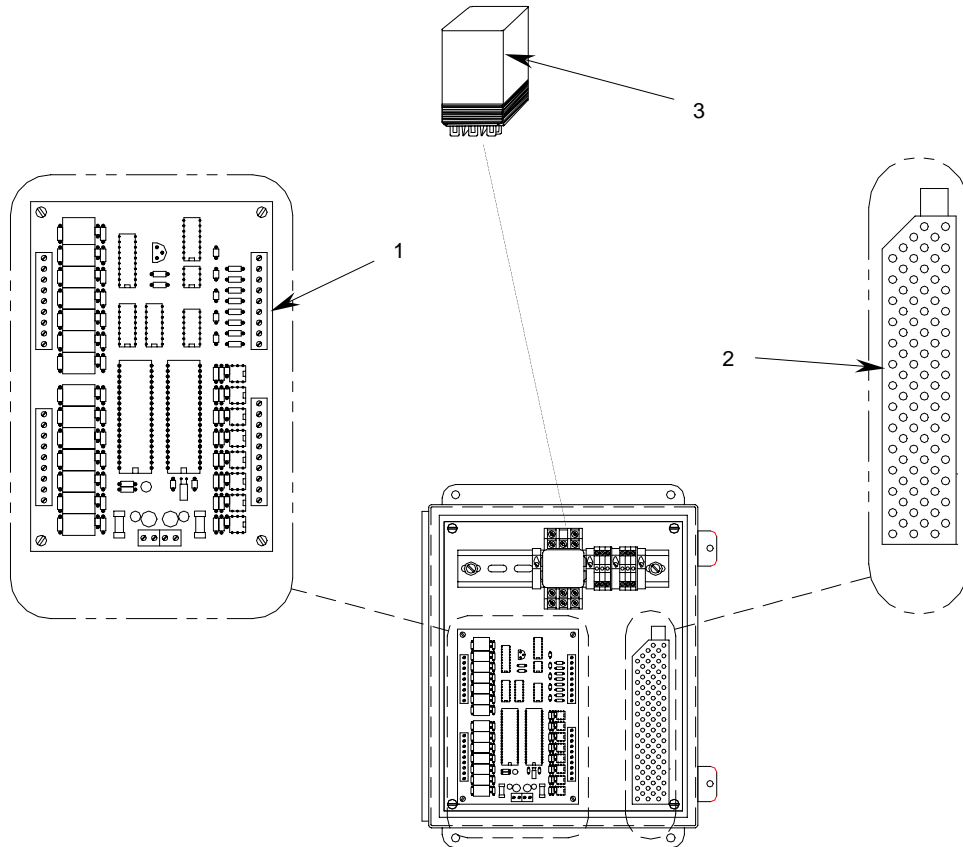

Figure 5. ECU Control Box.

**CONTAINERIZED KITCHEN (CK)  
GROUP 02 MECHANICAL ROOM REPAIR PARTS**

**0035 00**

(1) ITEM NO.	(2) SMR CODE	(3) NSN	(4) CAGEC	(5) PART NUMBER	(6) DESCRIPTION AND USABLE ON CODE (UOC)	(7) QTY
					GROUP 02 MECHANICAL ROOM FIGURE 5 ECU CONTROL BOX	
1	PAOZZ		0U5N7	47013014	BOARD, ECU CONTROLLER .....	1
2	PAOZZ		0XM44	800-1035	POWER SUPPLY .....	1
3	PAOZZ		0XM44	886-0340	RELAY.....	1
					END OF FIGURE	

---

CONTAINERIZED KITCHEN (CK)  
GROUP 02 MECHANICAL ROOM REPAIR PARTS

---

0035 00

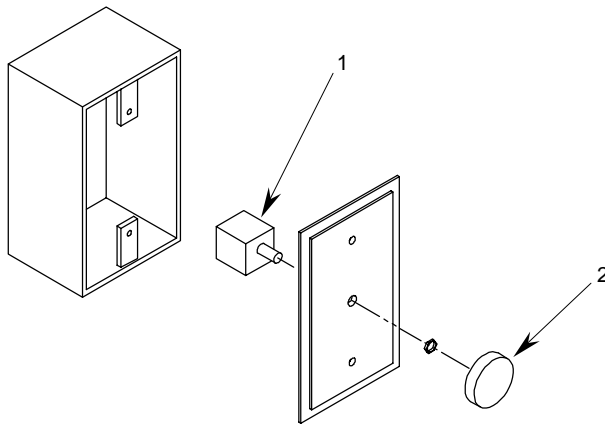

Figure 6. ECU Mode Switch Assembly.

**CONTAINERIZED KITCHEN (CK)  
GROUP 02 MECHANICAL ROOM REPAIR PARTS**

**0035 00**

(1) ITEM NO.	(2) SMR CODE	(3) NSN	(4) CAGEC	(5) PART NUMBER	(6) DESCRIPTION AND USABLE ON CODE (UOC)	(7) QTY
GROUP 02 MECHANICAL ROOM						
FIGURE 6 ECU MODE SWITCH ASSEMBLY						
1	PAOZZ		02929	HS13-Z	SWITCH, ROTARY, 4-POSITION.....	1
2	PAOZZ		0XM44	753-2454	. KNOB .....	1
END OF FIGURE						

---

CONTAINERIZED KITCHEN (CK)  
GROUP 02 MECHANICAL ROOM REPAIR PARTS

---

0035 00

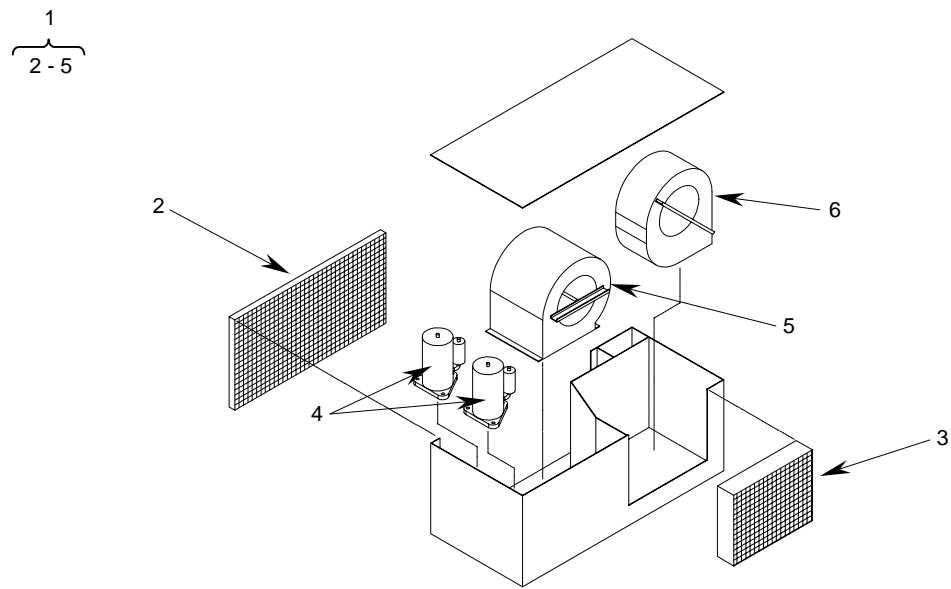

Figure 7. Air Conditioner.

**CONTAINERIZED KITCHEN (CK)  
GROUP 02 MECHANICAL ROOM REPAIR PARTS**

**0035 00**

(1) ITEM NO.	(2) SMR CODE	(3) NSN	(4) CAGEC	(5) PART NUMBER	(6) DESCRIPTION AND USABLE ON CODE (UOC)	(7) QTY
					GROUP 02 MECHANICAL ROOM FIGURE 7 AIR CONDITIONER	
1	PBFZZ		0U5N7	47011034	AIR CONDITIONER.....	2
2	XAFFF		1F3Y7	1452-1541	. COIL, CONDENSER.....	1
3	XAFFF		1F3Y7	1452-1531	. COIL, EVAPORATOR.....	1
4	XAFFF		1F3Y7	1450A2119	. COMPRESSOR.....	2
5	PBFZZ		1F3Y7	1468A3029	. MOTOR, BLOWER, CONDENSER.....	1
6	PBFZZ		1F3Y7	1468A3129	. MOTOR, BLOWER, EVAPORATOR.....	1
END OF FIGURE						



---

**CONTAINERIZED KITCHEN (CK)  
GROUP 02 MECHANICAL ROOM REPAIR PARTS**

---

0035 00

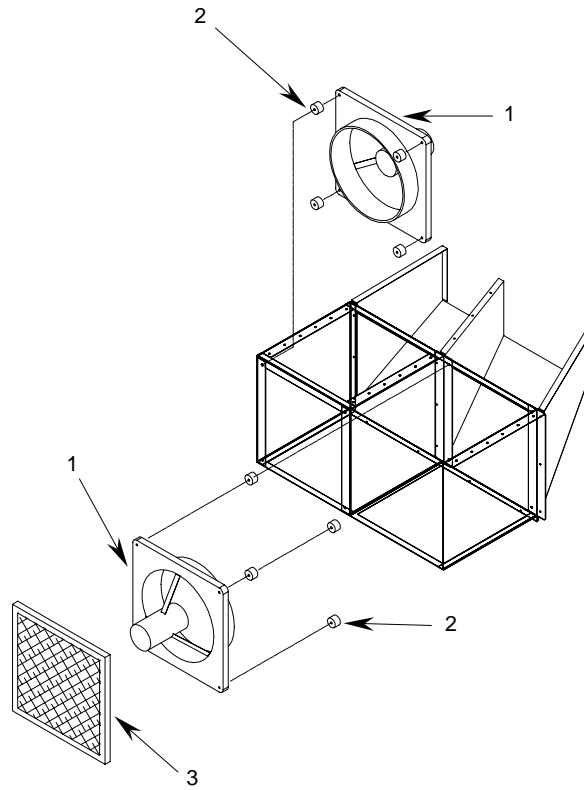

Figure 8. Intake and Exhaust Fan Installation

**CONTAINERIZED KITCHEN (CK)  
GROUP 02 MECHANICAL ROOM REPAIR PARTS**

**0035 00**

(1) ITEM NO.	(2) SMR CODE	(3) NSN	(4) CAGEC	(5) PART NUMBER	(6) DESCRIPTION AND USABLE ON CODE (UOC)	(7) QTY
					GROUP 02 MECHANICAL ROOM FIGURE 8 INTAKE AND EXHAUST FAN INSTALLATION	
1	PAOZZ		25795	4E35Q	FAN, MEDIUM PRESSURE, 14" BLADE, ALUMINUM SHROUD, 240V/60HZ .....	2
2	PAOZZ		39428	9376K113	VIBRATION MOUNT, NEOPRENE.....	8
3	PAOZZ		39428	2150K48	FILTER, AIR INTAKE.....	1
					END OF FIGURE	

THIS PAGE INTENTIONALLY LEFT BLANK

THIS PAGE INTENTIONALLY LEFT BLANK

---

**CONTAINERIZED KITCHEN (CK)  
GROUP 03 COOK CENTER REPAIR PARTS**

---

0036 00

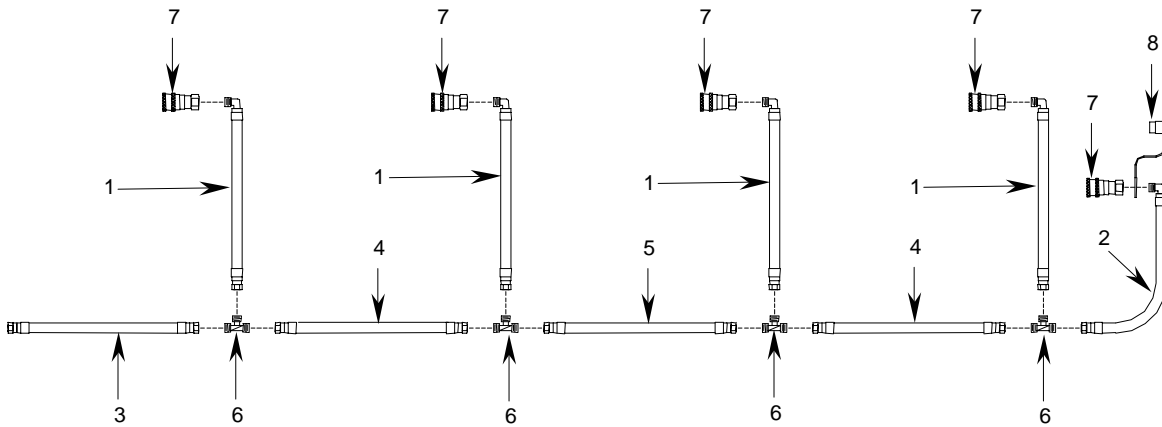

Figure 9. Fuel Line Assembly.

**CONTAINERIZED KITCHEN (CK)  
GROUP 03 COOK CENTER REPAIR PARTS**

**0036 00**

(1) ITEM NO.	(2) SMR CODE	(3) NSN	(4) CAGEC	(5) PART NUMBER	(6) DESCRIPTION AND USABLE ON CODE (UOC)	(7) QTY
					GROUP 03 COOK CENTER FIGURE 9 FUEL LINE ASSEMBLY	
1	PAOZZ		0U5N7	47012152-1	HOSE ASSEMBLY, FUEL, MALE ELBOW TO FEMALE, 24" .....	4
2	PAOZZ		0U5N7	47012152-3	HOSE ASSEMBLY, FUEL, MALE ELBOW TO FEMALE, 66" .....	1
3	PAOZZ		0U5N7	47012153-3	HOSE ASSEMBLY, FUEL, FEMALE SWIVEL BOTH ENDS, 84" .....	1
4	PAOZZ		0U5N7	47012153-1	HOSE ASSEMBLY, FUEL, FEMALE SWIVEL BOTH ENDS, 24" .....	2
5	PAOZZ		0U5N7	47012153-4	HOSE ASSEMBLY, FUEL, FEMALE SWIVEL BOTH ENDS, 36" .....	1
6	PAOZZ		7S077	44X	TEE, UNION, BRASS .....	4
7	PAOZZ	4730-00-795-6959	73992	B2-H16	COUPLING, FEMALE .....	5
8	PAOZZ	5340-01-144-2649	7S077	P-SDC-2-HK	PLUG, DUST .....	1
END OF FIGURE						

---

**CONTAINERIZED KITCHEN (CK)  
GROUP 03 COOK CENTER REPAIR PARTS**

---

**0036 00**

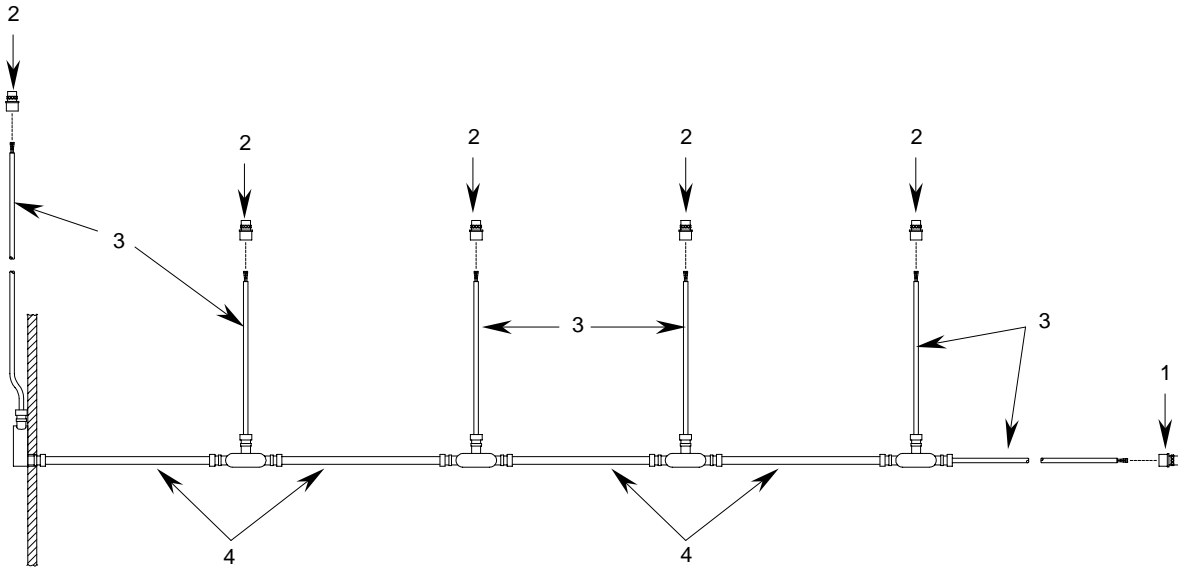

Figure 10. 24 VDC Power Cable Assembly.

**CONTAINERIZED KITCHEN (CK)  
GROUP 03 COOK CENTER REPAIR PARTS**

**0036 00**

(1) ITEM NO.	(2) SMR CODE	(3) NSN	(4) CAGEC	(5) PART NUMBER	(6) DESCRIPTION AND USABLE ON CODE (UOC)	(7) QTY
					GROUP 03 COOK CENTER FIGURE 10 24VDC POWER CABLE ASSEMBLY	
1	PAOZZ	5935-01-116-3615	96906	MS3106F16-11P	CONNECTOR, PLUG, MALE, 2-PIN.....1	
2	PAOZZ	5935-00-321-8295	96906	MS3106F16-11S	CONNECTOR, PLUG, FEMALE, 2-PIN .....5	
3	MOOZZ		0U5N7	47013007	CABLE, MAKE FROM WP 0045 00 ITEM 1..... V	
4	MOOZZ		0U5N7	47013007	CABLE, MAKE FROM WP 0045 00 ITEM 2 & 3..... V	
					END OF FIGURE	



THIS PAGE INTENTIONALLY LEFT BLANK

THIS PAGE INTENTIONALLY LEFT BLANK

---

CONTAINERIZED KITCHEN (CK)  
GROUP 05 DUAL OVEN ASSEMBLY REPAIR PARTS

---

0037 00

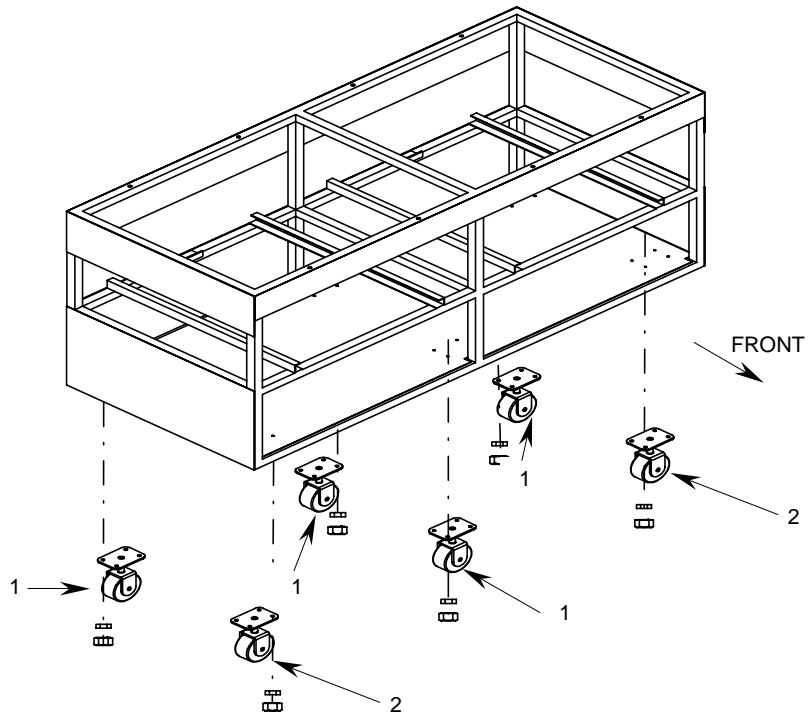

Figure 11. Oven Base Assembly.

**CONTAINERIZED KITCHEN (CK)  
GROUP 05 DUAL OVEN ASSEMBLY REPAIR PARTS**

**0037 00**

(1) ITEM NO.	(2) SMR CODE	(3) NSN	(4) CAGEC	(5) PART NUMBER	(6) DESCRIPTION AND USABLE ON CODE (UOC)	(7) QTY
					GROUP 05 DUAL OVEN ASSEMBLY FIGURE 11 OVEN BASE ASSEMBLY	
1	PBOZZ		39428	2370T11	CASTER, SWIVEL.....	4
2	PBOZZ		39428	2370T31	CASTER, SWIVEL, WITH BRAKE.....	2
					END OF FIGURE	

---

CONTAINERIZED KITCHEN (CK)  
GROUP 05 DUAL OVEN ASSEMBLY REPAIR PARTS

---

0037 00

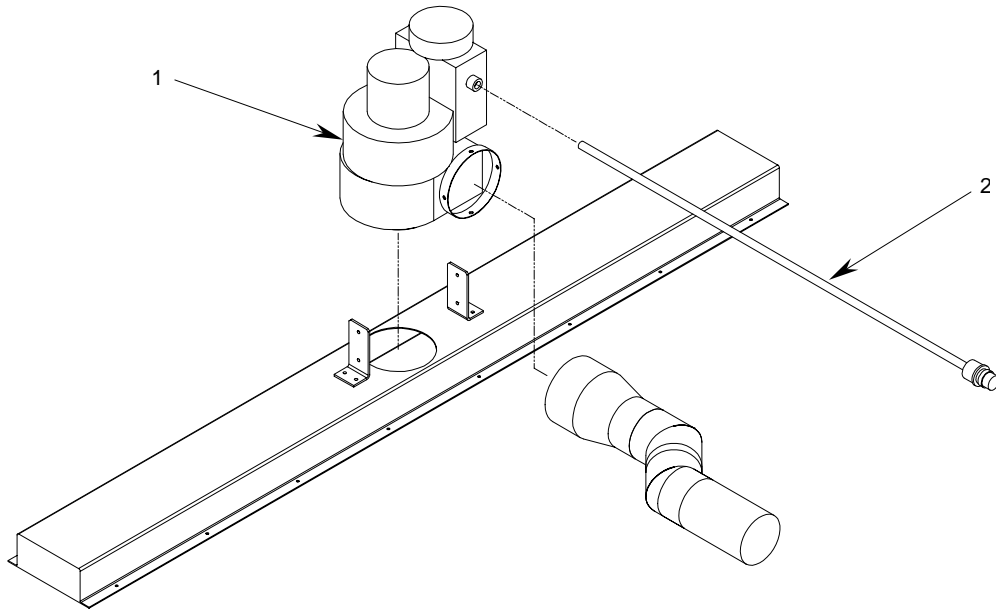

Figure 12. Oven Fan Assembly.

**CONTAINERIZED KITCHEN (CK)  
GROUP 05 DUAL OVEN ASSEMBLY REPAIR PARTS**

**0037 00**

(1) ITEM NO.	(2) SMR CODE	(3) NSN	(4) CAGEC	(5) PART NUMBER	(6) DESCRIPTION AND USABLE ON CODE (UOC)	(7) QTY
					GROUP 05 DUAL OVEN ASSEMBLY FIGURE 12 OVEN FAN ASSEMBLY	
1	PAOZZ		25795	4C727	BLOWER.....	1
2	PAOZZ		097M6	40905	ASSEMBLY, POWER CABLE .....	1
END OF FIGURE						

---

**CONTAINERIZED KITCHEN (CK)  
GROUP 05 DUAL OVEN ASSEMBLY REPAIR PARTS**

---

0037 00

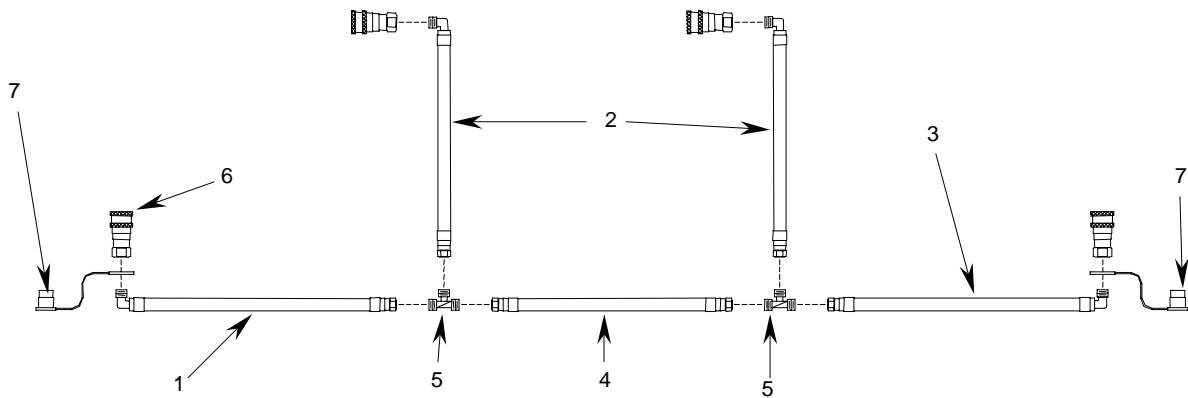

Figure 13. Fuel Line Assembly.

**CONTAINERIZED KITCHEN (CK)  
GROUP 05 DUAL OVEN ASSEMBLY REPAIR PARTS**

**0037 00**

(1) ITEM NO.	(2) SMR CODE	(3) NSN	(4) CAGEC	(5) PART NUMBER	(6) DESCRIPTION AND USABLE ON CODE (UOC)	(7) QTY
					GROUP 05 DUAL OVEN ASSEMBLY	
					FIGURE 13 FUEL LINE ASSEMBLY	
1	PAOZZ		0U5N7	47012152-5	HOSE ASSEMBLY, FUEL, MALE ELBOW TO FEMALE, 114" .....	1
2	PAOZZ		0U5N7	47012152-2	HOSE ASSEMBLY, FUEL, MALE ELBOW TO FEMALE, 36" .....	2
3	PAOZZ		0U5N7	47012152-4	HOSE ASSEMBLY, FUEL, MALE ELBOW TO FEMALE, 84" .....	1
4	PAOZZ		0U5N7	47012153-2	HOSE ASSEMBLY, FUEL, FEMALE SWIVEL BOTH ENDS, 27-1/4" .....	1
5	PAOZZ		7S077	44X	TEE, UNION, BRASS .....	2
6	PAOZZ	4730-00-795-6959	73992	B2-H16	COUPLING, FEMALE .....	4
7	PAOZZ	5340-01-144-2649	7S077	P-SDC-2-HK	PLUG, DUST .....	2
					END OF FIGURE	



---

CONTAINERIZED KITCHEN (CK)  
GROUP 05 DUAL OVEN ASSEMBLY REPAIR PARTS

---

0037 00

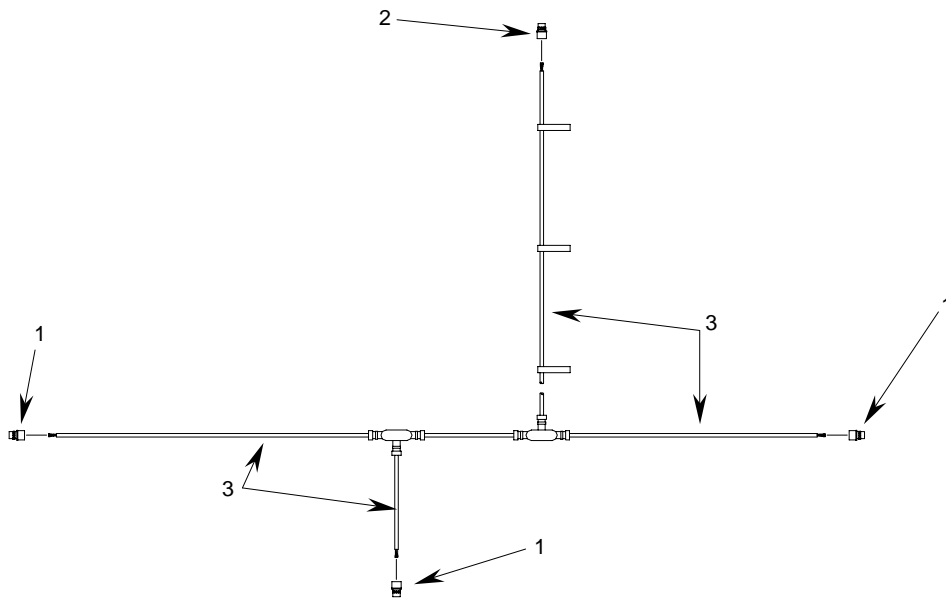

Figure 14. 24 VDC Power Cable Assembly.

**CONTAINERIZED KITCHEN (CK)  
GROUP 05 DUAL OVEN ASSEMBLY REPAIR PARTS**

**0037 00**

(1) ITEM NO.	(2) SMR CODE	(3) NSN	(4) CAGEC	(5) PART NUMBER	(6) DESCRIPTION AND USABLE ON CODE (UOC)	(7) QTY
					GROUP 05 DUAL OVEN ASSEMBLY	
					FIGURE 14 24 VDC POWER CABLE ASSEMBLY	
1	PAOZZ	5935-00-321-8295	96906	MS3106F16-11S	CONNECTOR, PLUG, FEMALE, 2-PIN.....3	
2	PAOZZ	5935-01-116-3615	96906	MS3106F16-11P	CONNECTOR, PLUG, MALE, 2-PIN.....1	
3	MOOZZ		0U5N7	47013009	CABLE, MAKE FROM WP 0045 00 ITEM 1..... V	
					END OF FIGURE	

THIS PAGE INTENTIONALLY LEFT BLANK

THIS PAGE INTENTIONALLY LEFT BLANK

CONTAINERIZED KITCHEN (CK)  
GROUP 06 MOBILE WARMING CABINET REPAIR PARTS

0038 00

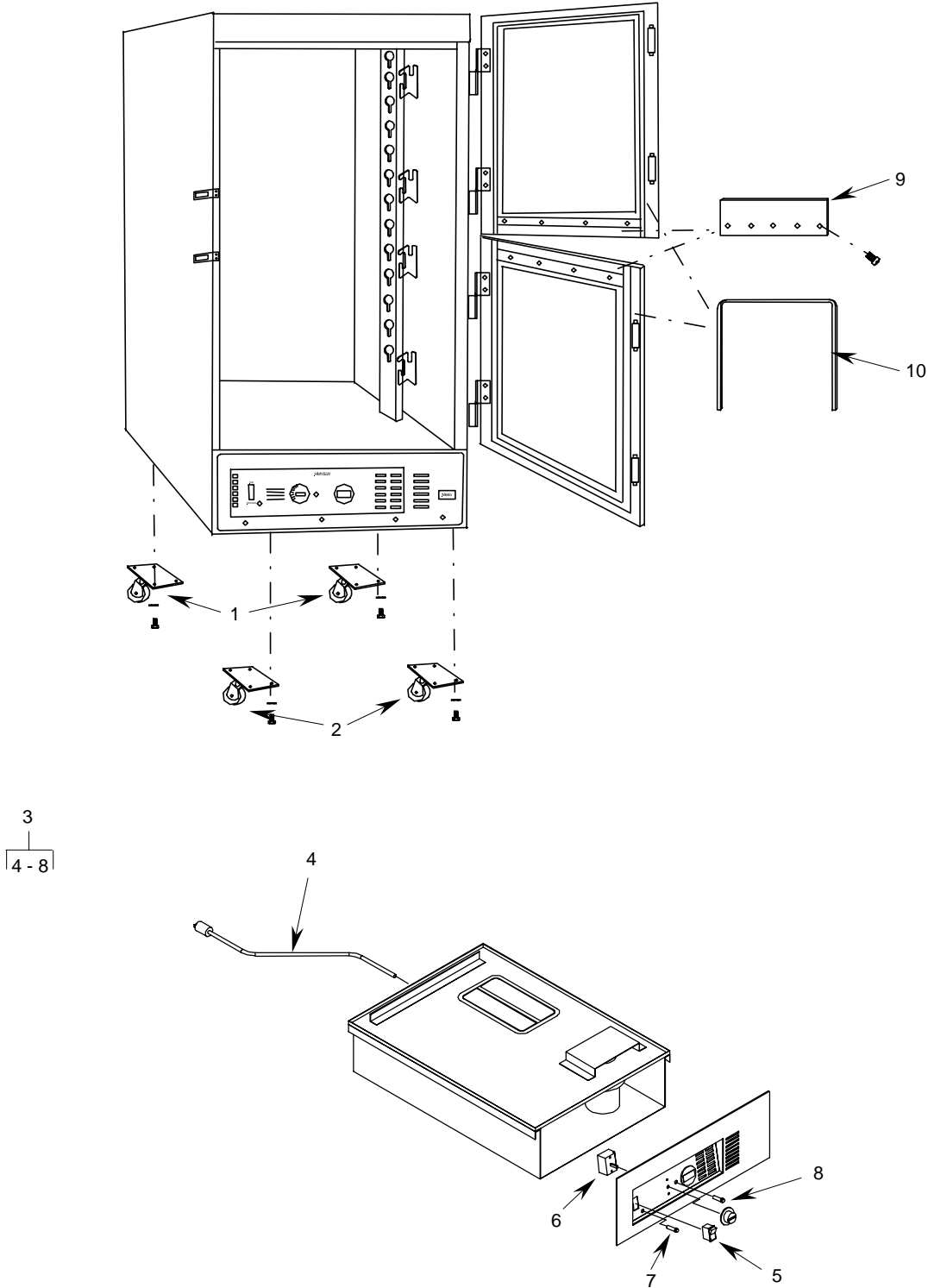

Figure 15. Mobile Warming Cabinet.

**CONTAINERIZED KITCHEN (CK)  
GROUP 06 MOBILE WARMING CABINET REPAIR PARTS**

**0038 00**

(1) ITEM NO.	(2) SMR CODE	(3) NSN	(4) CAGEC	(5) PART NUMBER	(6) DESCRIPTION AND USABLE ON CODE (UOC)	(7) QTY
					GROUP 06 MOBILE WARMING CABINET FIGURE 15 MOBILE WARMING CABINET	
1	PBOZZ		40038	RPB5D	CASTER, SWIVEL.....	2
2	PBOZZ		40038	RPB5NB	CASTER, SWIVEL, WITH BRAKE .....	2
3	PBOZZ		40038	C199-HM2000	MODULE .....	1
4	PAOZZ		0U5N7	47013012	. ASSEMBLY, POWER CORD.....	1
5	PAOZZ		40038	RPC13-127	. SWITCH, POWER .....	1
6	PAOZZ		40038	RPC13-129	. THERMOSTAT .....	1
7	PAOZZ		40038	RPC13-105	. LIGHT, INDICATOR, YELLOW .....	1
8	PAOZZ		40038	RPC13-064	. LIGHT, INDICATOR, RED .....	1
9	PBOZZ		40038	RPC07-032- 23.250	SEAL, DOOR.....	2
10	PBOZZ		40038	RPC06-317	GASKET, DOOR .....	2
					END OF FIGURE	

THIS PAGE INTENTIONALLY LEFT BLANK

THIS PAGE INTENTIONALLY LEFT BLANK



CONTAINERIZED KITCHEN (CK)  
GROUP 07 REFRIGERATOR REPAIR PARTS

0039 00

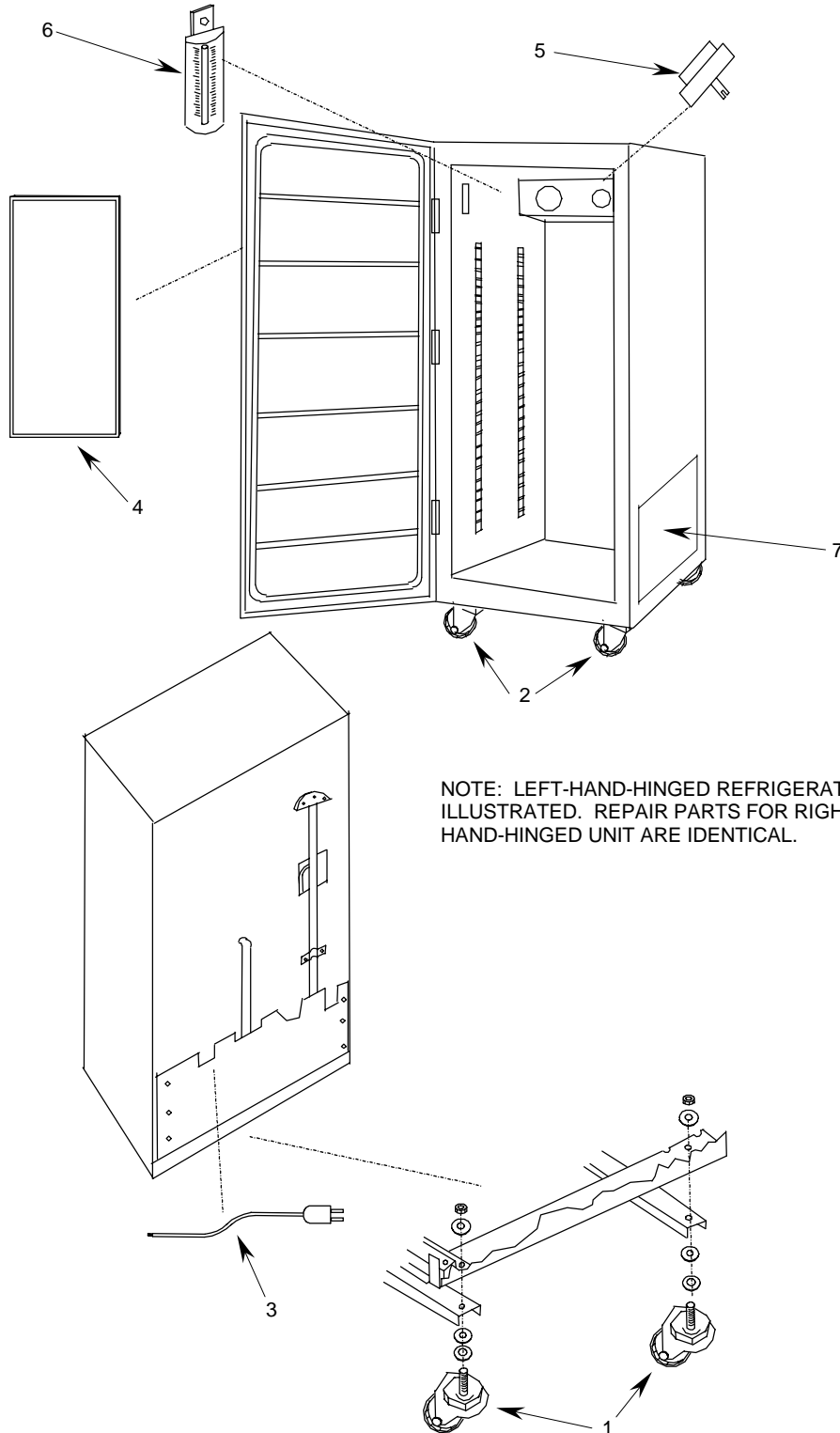

Figure 16. Refrigerator.  
0039 00-1 Blank/2

**CONTAINERIZED KITCHEN (CK)  
GROUP 07 REFRIGERATOR REPAIR PARTS**

**0039 00**

(1) ITEM NO.	(2) SMR CODE	(3) NSN	(4) CAGEC	(5) PART NUMBER	(6) DESCRIPTION AND USABLE ON CODE (UOC)	(7) QTY
					GROUP 07 REFRIGERATORS	
					FIGURE 16 REFRIGERATOR	
1	PBOZZ		9R633	18202-002	CASTER, SWIVEL.....	2
2	PBOZZ		9R633	18202-001	CASTER, SWIVEL, WITH BRAKE .....	2
3	PAOZZ		0U5N7	47013012	ASSEMBLY, POWER CORD.....	1
4	PBOZZ		9R633	17963-000	GASKET, DOOR .....	1
5	PAOZZ		9R633	16830-000	TEMPERATURE CONTROL .....	1
6	PBOZZ		9R633	17465-000	THERMOMETER.....	1
7	PAOZZ		39428	8689K31	FILM, POLYESTER, CLEAR, 2 MIL, ADHESIVE-BACKED.....	2
					END OF FIGURE	

THIS PAGE INTENTIONALLY LEFT BLANK

THIS PAGE INTENTIONALLY LEFT BLANK

---

**CONTAINERIZED KITCHEN (CK)  
GROUP 08 TRAY PACK HEATER REPAIR PARTS**

---

0040 00

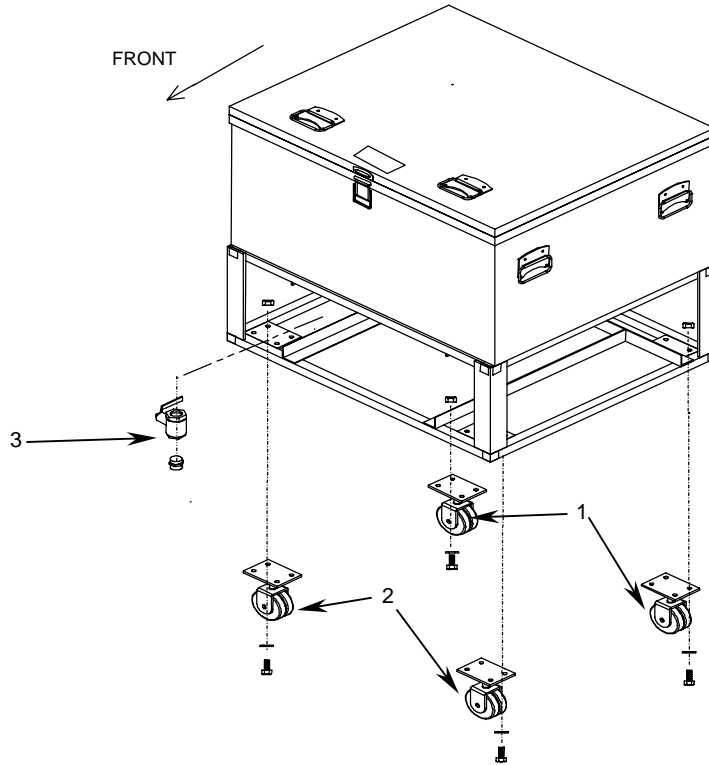

Figure 17. Tray Pack Heater

**CONTAINERIZED KITCHEN (CK)  
GROUP 08 TRAY PACK HEATER REPAIR PARTS**

**0040 00**

(1) ITEM NO.	(2) SMR CODE	(3) NSN	(4) CAGEC	(5) PART NUMBER	(6) DESCRIPTION AND USABLE ON CODE (UOC)	(7) QTY
					GROUP 08 TRAY PACK HEATER FIGURE 17 TRAY PACK HEATER	
1	PBOZZ		39428	9908T18	CASTER, SWIVEL.....	2
2	PBOZZ		39428	9908T31	CASTER, SWIVEL, WITH BRAKE.....	2
3	PAOZZ		79227	9943	VALVE, DRAIN.....	1
					END OF FIGURE	

---

CONTAINERIZED KITCHEN (CK)  
GROUP 08 TRAY PACK HEATER REPAIR PARTS

---

0040 00

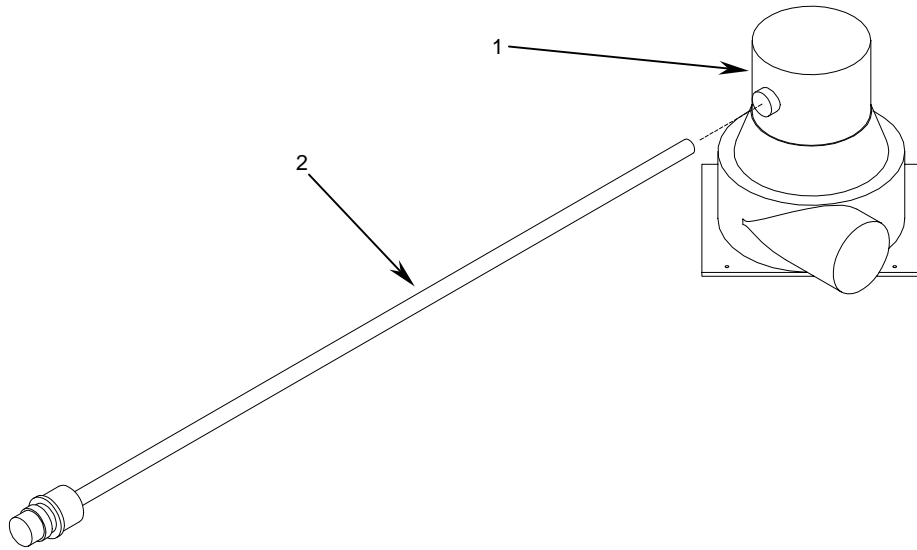

Figure 18. Heater Fan Assembly.

**CONTAINERIZED KITCHEN (CK)  
GROUP 08 TRAY PACK HEATER REPAIR PARTS**

**0040 00**

(1) ITEM NO.	(2) SMR CODE	(3) NSN	(4) CAGEC	(5) PART NUMBER	(6) DESCRIPTION AND USABLE ON CODE (UOC)	(7) QTY
					GROUP 08 TRAY PACK HEATER FIGURE 18 HEATER FAN ASSEMBLY	
1	PAOZZ		0LD16	A128	BLOWER.....	1
2	PAOZZ		097M6	40905	ASSEMBLY, POWER CABLE .....	1
					END OF FIGURE	



THIS PAGE INTENTIONALLY LEFT BLANK

THIS PAGE INTENTIONALLY LEFT BLANK

CONTAINERIZED KITCHEN (CK)  
GROUP 09 HAND SINK ASSEMBLY REPAIR PARTS

0041 00

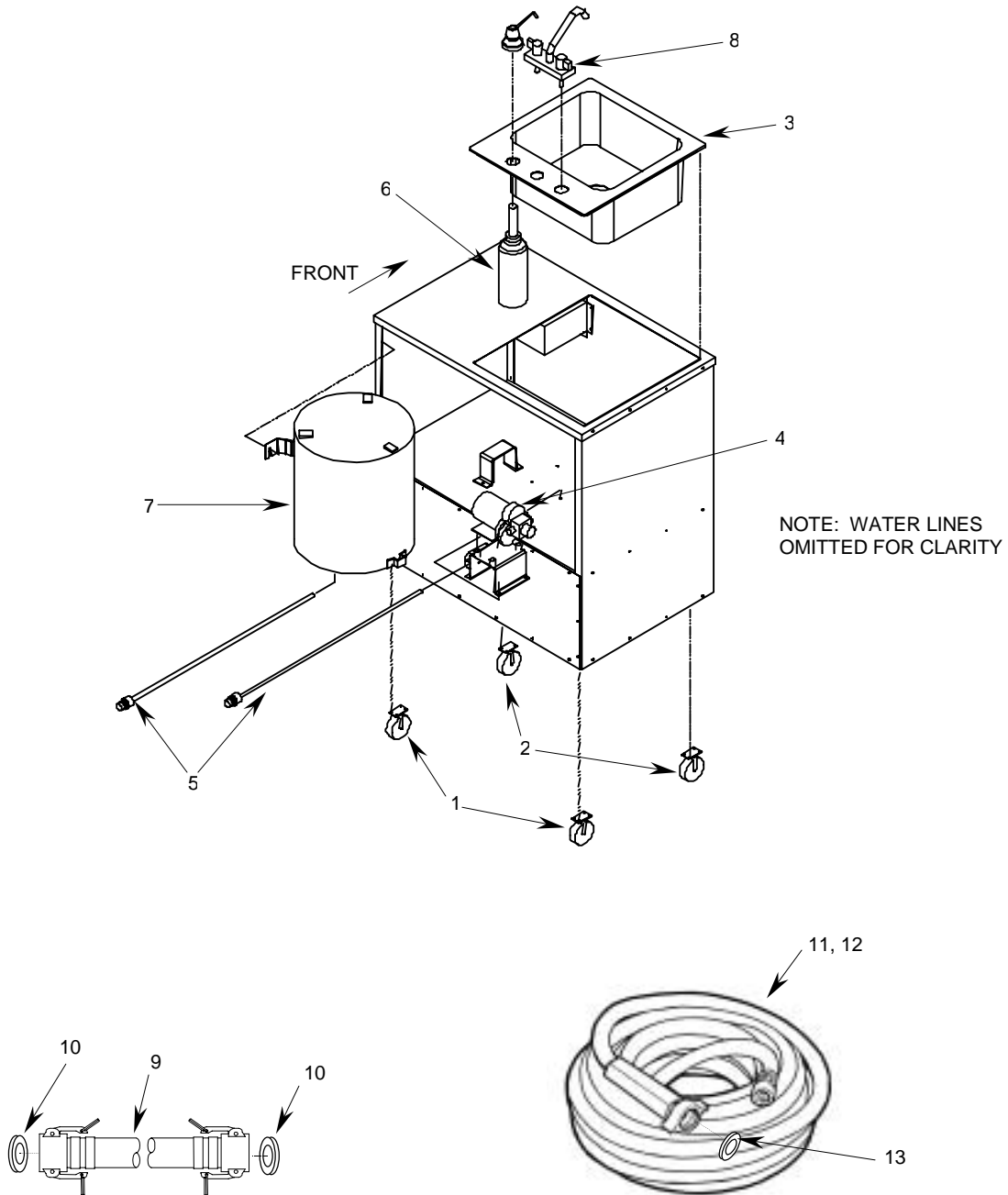

Figure 19. Hand Sink Assembly.

**CONTAINERIZED KITCHEN (CK)  
GROUP 09 HAND SINK ASSEMBLY REPAIR PARTS**

**0041 00**

(1) ITEM NO.	(2) SMR CODE	(3) NSN	(4) CAGEC	(5) PART NUMBER	(6) DESCRIPTION AND USABLE ON CODE (UOC)	(7) QTY
					GROUP 09 HAND SINK ASSEMBLY	
					FIGURE 19 HAND SINK ASSEMBLY	
1	PBOZZ		39428	22785T63	CASTER, SWIVEL.....	2
2	PBOZZ		39428	22785T68	CASTER, SWIVEL, WITH BRAKE .....	2
3	XDOZZ		39428	23605K52	SINK, HAND .....	1
4	PAOZZ		09BX1	2088-594-154	PUMP, WATER .....	1
5	PAOZZ		097M6	40905	ASSEMBLY, POWER CABLE .....	2
6	PAOZZ		39428	2773K1	DISPENSER, SOAP .....	1
7	PAOZZ		86458	M-I-WH6U3SS	HEATER, WATER .....	1
8	PAOZZ		20247	LK-2490	FAUCET, LAUNDRY, HOSE THREADED .....	1
9	PAOZZ		0U5N7	47011050-2	HOSE ASSEMBLY, INTERNAL DRAIN .....	1
10	PAOZZ		7S077	B03	. GASKET, BUNA N.....	2
11	PAOZZ		39428	6226T12	HOSE, WATER SUPPLY, 50-FT .....	1
12	PAOZZ		39428	6226T11	HOSE, WATER SUPPLY, 25-FT .....	2
13	PAOZZ		39428	66215T78	. WASHER, HOSE .....	3
					END OF FIGURE	

THIS PAGE INTENTIONALLY LEFT BLANK

THIS PAGE INTENTIONALLY LEFT BLANK

---

**CONTAINERIZED KITCHEN (CK)  
GROUP 10 MOBILE STORAGE CABINET REPAIR PARTS**

---

0042 00

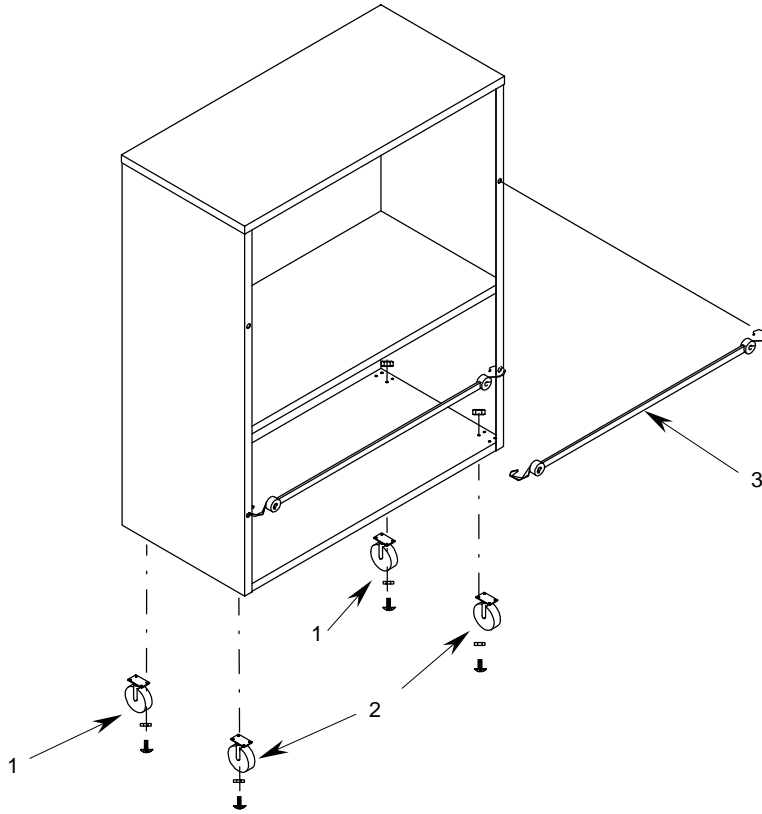

Figure 20. Mobile Storage Cabinet.

**CONTAINERIZED KITCHEN (CK)  
GROUP 10 MOBILE STORAGE CABINET REPAIR PARTS**

**0042 00**

(1) ITEM NO.	(2) SMR CODE	(3) NSN	(4) CAGEC	(5) PART NUMBER	(6) DESCRIPTION AND USABLE ON CODE (UOC)	(7) QTY
					GROUP 10 MOBILE STORAGE CABINETS	
					FIGURE 20 MOBILE STORAGE CABINET	
1	PBOZZ		39428	22785T63	CASTER, SWIVEL.....	2
2	PBOZZ		39428	22785T68	CASTER, SWIVEL, WITH BRAKE .....	2
3	PAOZZ	2030-01-168-9371	39428	3891T16	TIE-DOWN, MOLDED RUBBER, 28".....	2
					END OF FIGURE	



THIS PAGE INTENTIONALLY LEFT BLANK

THIS PAGE INTENTIONALLY LEFT BLANK

---

CONTAINERIZED KITCHEN (CK)  
GROUP 11 PREP/SERVING TABLE REPAIR PARTS

---

0043 00

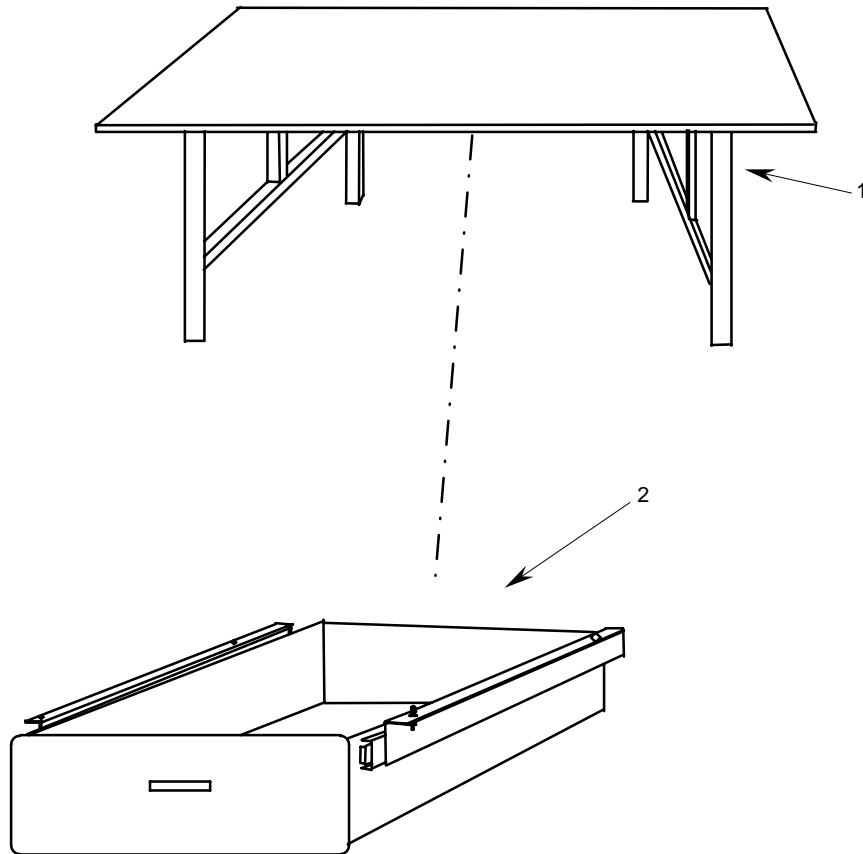

Figure 21. Prep/Serving Table.

**CONTAINERIZED KITCHEN (CK)  
GROUP 11 PREP/SERVING TABLE REPAIR PARTS**

**0043 00**

(1) ITEM NO.	(2) SMR CODE	(3) NSN	(4) CAGEC	(5) PART NUMBER	(6) DESCRIPTION AND USABLE ON CODE (UOC)	(7) QTY
					GROUP 11 PREP/SERVING TABLES	
					FIGURE 21 PREP/SERVING TABLE	
1	PBOZZ		0U5N7	47011049	TABLE, FIELD, ALTERED.....	4
2	PBOZZ		0U5N7	47011047	ASSEMBLY, TABLE DRAWER.....	2
					END OF FIGURE	

THIS PAGE INTENTIONALLY LEFT BLANK

THIS PAGE INTENTIONALLY LEFT BLANK

---

**CONTAINERIZED KITCHEN (CK)  
GROUP 12 ELECTRICAL SYSTEM REPAIR PARTS**

---

0044 00

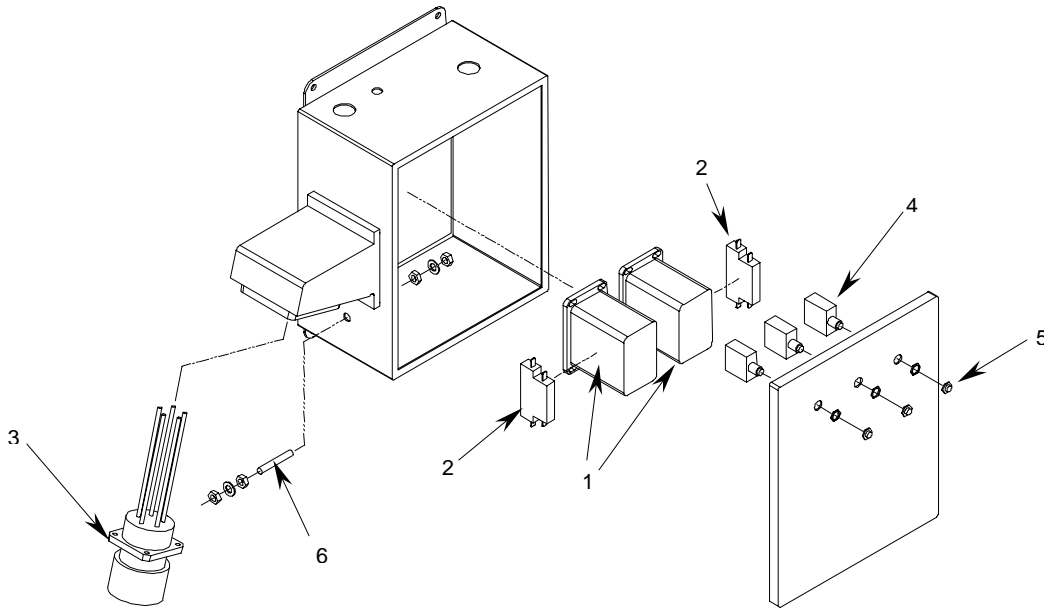

Figure 22. Power Entrance Panel.

**CONTAINERIZED KITCHEN (CK)  
GROUP 12 ELECTRICAL SYSTEM REPAIR PARTS**

**0044 00**

(1) ITEM NO.	(2) SMR CODE	(3) NSN	(4) CAGEC	(5) PART NUMBER	(6) DESCRIPTION AND USABLE ON CODE (UOC)	(7) QTY
					GROUP 12 ELECTRICAL SYSTEM FIGURE 22 POWER ENTRANCE PANEL	
1	PAOZZ		097M6	DPA63-VO2	CONTACTOR, 3-POLE, 60 AMP.....	2
2	PAOZZ		097M6	DPA-D11	CONTACTOR, AUXILIARY.....	2
3	PAOZZ		0U5N7	47013023	ASSEMBLY, RECEPTACLE, EXTERNAL POWER .....	1
4	PAOZZ		097M6	W58-XB4A4A-5	CIRCUIT BREAKER, 5 AMP.....	3
5	PAOZZ		097M6	N3030B	BOOT, PUSHBUTTON.....	3
6	PAOZZ		39428	98812A030	TERMINAL, GROUND.....	1
END OF FIGURE						



**CONTAINERIZED KITCHEN (CK)  
GROUP 12 ELECTRICAL SYSTEM REPAIR PARTS**

0044 00

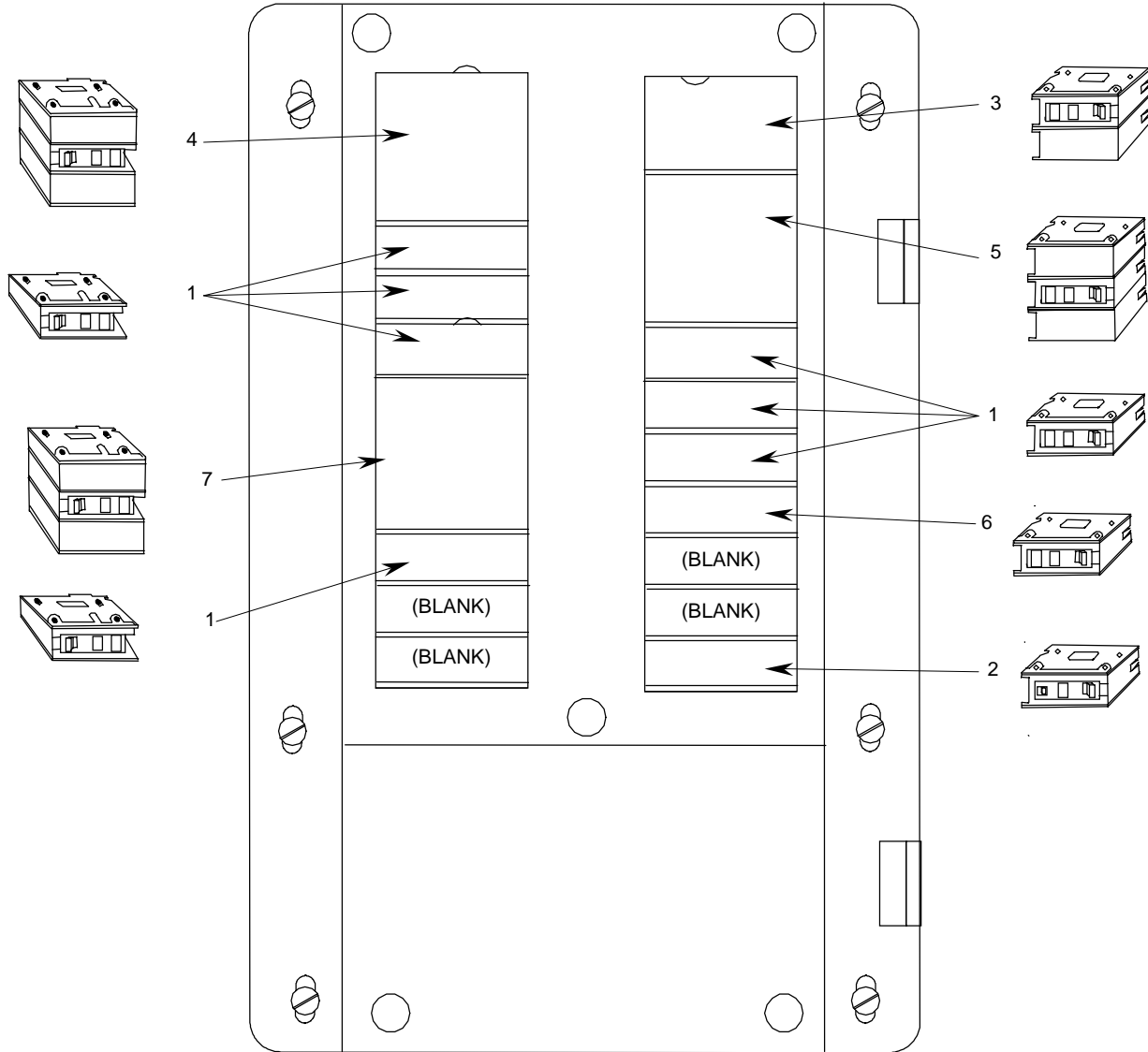

Figure 23. Power Distribution Panel.

**CONTAINERIZED KITCHEN (CK)  
GROUP 12 ELECTRICAL SYSTEM REPAIR PARTS**

**0044 00**

(1) ITEM NO.	(2) SMR CODE	(3) NSN	(4) CAGEC	(5) PART NUMBER	(6) DESCRIPTION AND USABLE ON CODE (UOC)	(7) QTY
GROUP 12 ELECTRICAL SYSTEM FIGURE 23 POWER DISTRIBUTION PANEL						
1	PAOZZ	5925-00-984-2163	56303	QOB115	CIRCUIT BREAKER, 1 POLE, 15 A.....	7
2	PAOZZ	5925-01-018-3014	56303	QOB115GFI	CIRCUIT BREAKER, 1 POLE, 15 A, GFI.....	1
3	PAOZZ	5925-01-245-6479	56303	QOB210	CIRCUIT BREAKER, 2 POLE 10 A.....	1
4	PAOZZ	5925-00-936-3933	56303	QOB360	CIRCUIT BREAKER, 3 POLE, 60 A.....	1
5	PAOZZ	5925-00-983-5666	56303	QOB315	CIRCUIT BREAKER, 3 POLE, 15 A.....	1
6	PAOZZ	5925-01-056-5127	56303	QOB110	CIRCUIT BREAKER, 1 POLE, 10 A.....	1
7	PAOZZ	5925-00-728-1969	56365	QOB330	CIRCUIT BREAKER, 3 POLE, 30 A.....	1
END OF FIGURE						

---

**CONTAINERIZED KITCHEN (CK)  
GROUP 12 ELECTRICAL SYSTEM REPAIR PARTS**

---

0044 00

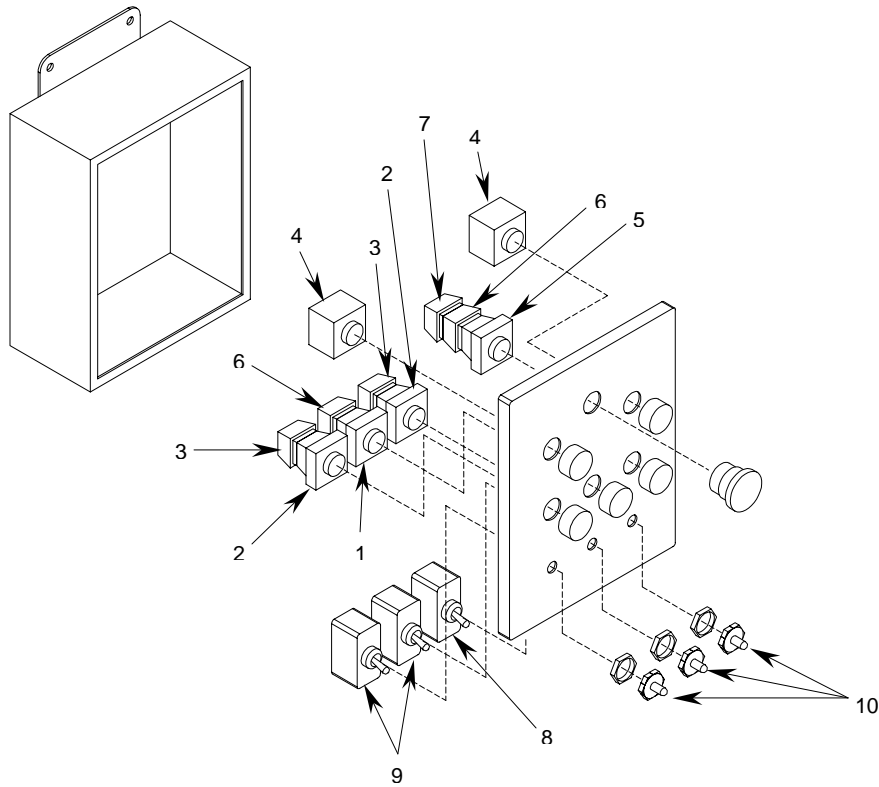

Figure 24. Main Control Panel.

**CONTAINERIZED KITCHEN (CK)  
GROUP 12 ELECTRICAL SYSTEM REPAIR PARTS**

**0044 00**

(1) ITEM NO.	(2) SMR CODE	(3) NSN	(4) CAGEC	(5) PART NUMBER	(6) DESCRIPTION AND USABLE ON CODE (UOC)	(7) QTY
					GROUP 12 ELECTRICAL SYSTEM FIGURE 24 MAIN CONTROL PANEL	
1	PAOZZ	5930-01-302-9739	0ET52	ZB2BA2	PUSH BUTTON, MOMENTARY .....	1
2	PAOZZ	5930-01-367-5513	52090	ZB2BW33	PUSH BUTTON, ILLUMINATED, GREEN .....	2
3	PAOZZ	5930-01-291-5467	52090	ZB2BW061	CONTACT BLOCK, LIGHT MODULE .....	2
4	PAOZZ	6210-01-172-5978	37833	ZB2BV05	LIGHT, PILOT, AMBER .....	2
5	PAOZZ	5930-01-306-9740	37833	ZB2BT4	PUSH BUTTON, RED, 40 MM, MAINTAINED .....	1
6	PAOZZ	5930-01-174-8604	37833	ZB2BZ104	CONTACT BLOCK, 2 N.C. CIRCUITS .....	2
7	PAOZZ	5920-01-289-0884	52090	ZB2BZ102	CONTACT BLOCK, 1 N.C. CIRCUIT .....	1
8	PAOZZ		097M6	HBL22SP	SWITCH, TOGGLE, DPDT, SPADE TERMINAL .....	1
9	PAOZZ		097M6	HBL11SP	SWITCH, TOGGLE, SPST, SPADE TERMINAL .....	2
10	PAOZZ		097M6	SSB1	BOOT, SWITCH .....	3
					END OF FIGURE	

---

**CONTAINERIZED KITCHEN (CK)  
GROUP 12 ELECTRICAL SYSTEM REPAIR PARTS**

---

0044 00

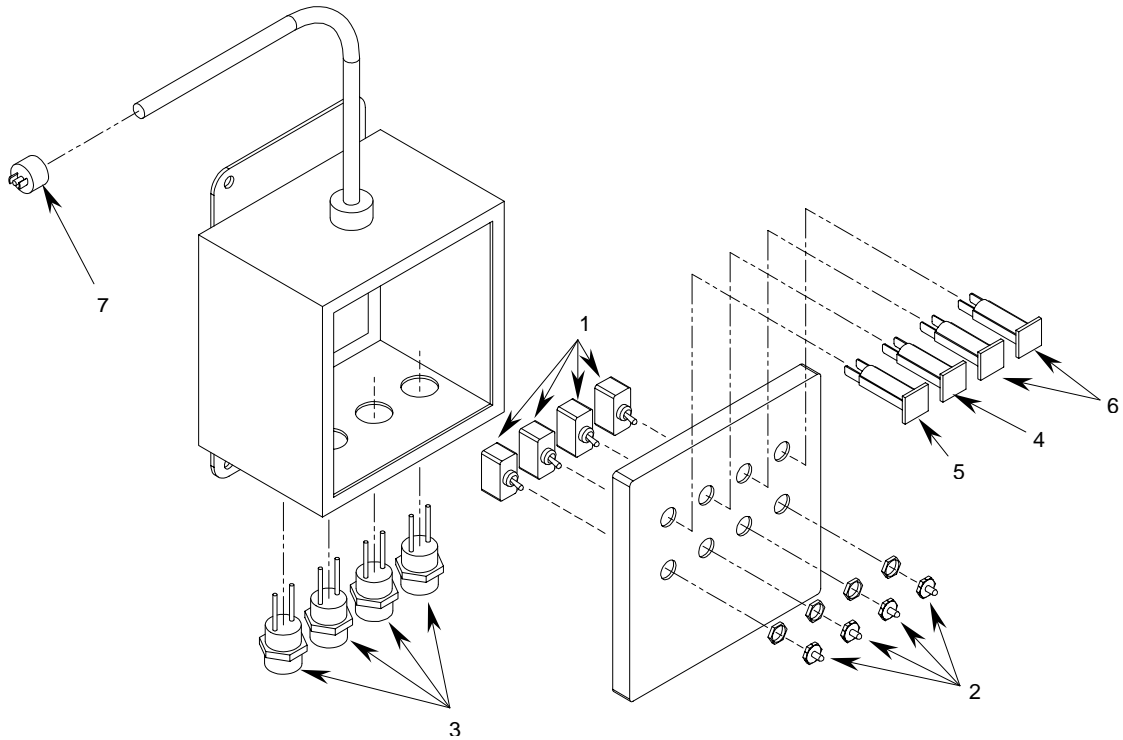

Figure 25. Appliance Control Box.

**CONTAINERIZED KITCHEN (CK)  
GROUP 12 ELECTRICAL SYSTEM REPAIR PARTS**

**0044 00**

(1) ITEM NO.	(2) SMR CODE	(3) NSN	(4) CAGEC	(5) PART NUMBER	(6) DESCRIPTION AND USABLE ON CODE (UOC)	(7) QTY
GROUP 12 ELECTRICAL SYSTEM FIGURE 25 APPLIANCE CONTROL BOX						
1	PAOZZ		097M6	HBL11SP	SWITCH, TOGGLE, SPST, SPADE TERMINAL.....4	
2	PAOZZ		097M6	SSB1	BOOT, SWITCH .....4	
3	PAOZZ		097M6	40910	RECEPTACLE, MINI-CHANGE, 3-POLE..... 4	
4	PAOZZ	5925-01-280-0280	77342	W28XQ1A-2	CIRCUIT BREAKER, 2 A..... 1	
5	PAOZZ		097M6	W28XQ1A-6	CIRCUIT BREAKER, 6 A..... 1	
6	PAOZZ	5925-01-299-1282	77342	W28XQ1A-1	CIRCUIT BREAKER, 1 A..... 2	
7	PAOZZ		097M6	7594V	PLUG, TWIST-LOC, 15 A IDC ..... 1	
END OF FIGURE						

---

**CONTAINERIZED KITCHEN (CK)  
GROUP 12 ELECTRICAL SYSTEM REPAIR PARTS**

---

0044 00

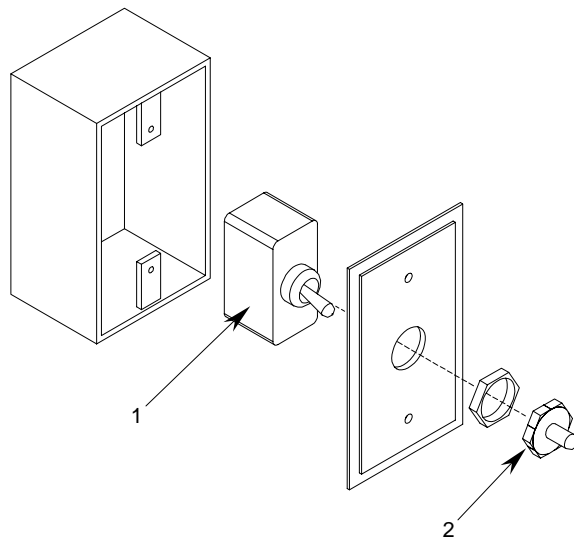

Figure 26. MBU Power Switch Assembly.

**CONTAINERIZED KITCHEN (CK)  
GROUP 12 ELECTRICAL SYSTEM REPAIR PARTS**

**0044 00**

(1) ITEM NO.	(2) SMR CODE	(3) NSN	(4) CAGEC	(5) PART NUMBER	(6) DESCRIPTION AND USABLE ON CODE (UOC)	(7) QTY
					GROUP 12 ELECTRICAL SYSTEM FIGURE 26 MBU POWER SWITCH ASSEMBLY	
1	PAOZZ		097M6	HBL11SP	SWITCH, TOGGLE, SPST, SPADE TERMINAL.....	1
2	PAOZZ		097M6	SSB1	BOOT, SWITCH .....	1
					END OF FIGURE	



CONTAINERIZED KITCHEN (CK)  
GROUP 12 ELECTRICAL SYSTEM REPAIR PARTS

0044 00

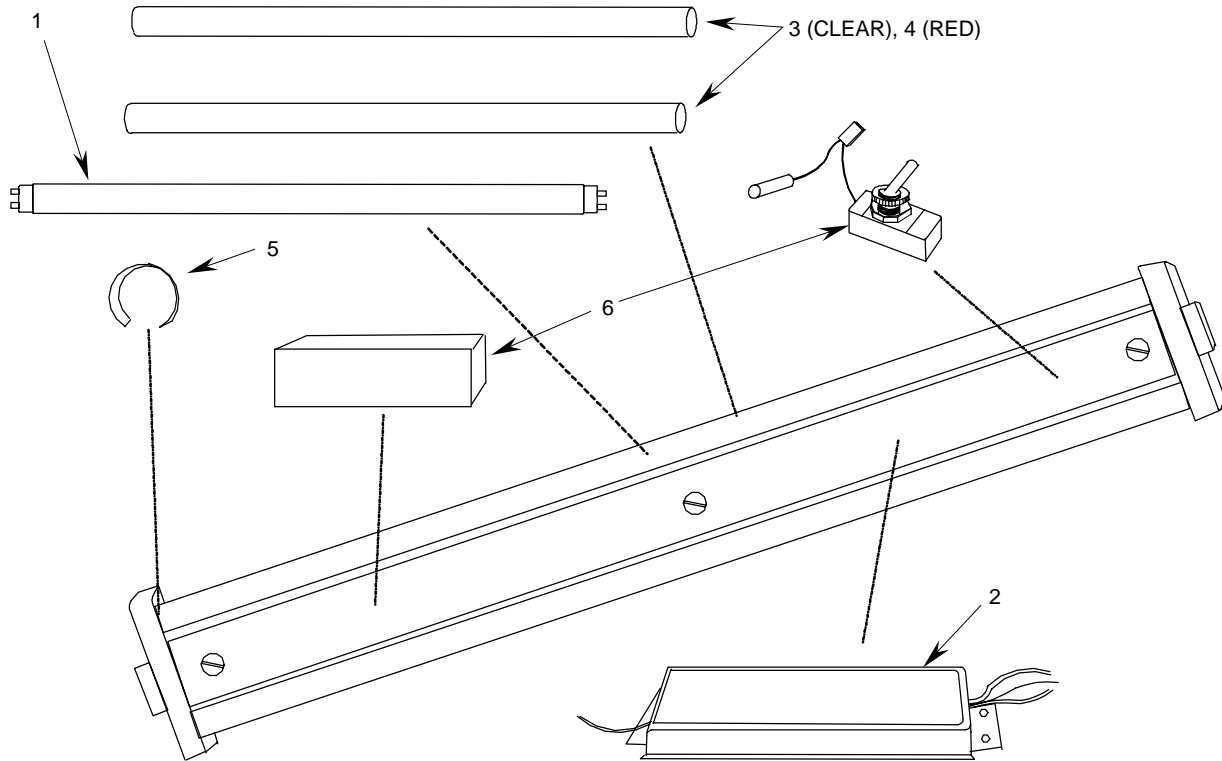

Figure 27. Ceiling Light – Fixed.

**CONTAINERIZED KITCHEN (CK)  
GROUP 12 ELECTRICAL SYSTEM REPAIR PARTS**

**0044 00**

(1) ITEM NO.	(2) SMR CODE	(3) NSN	(4) CAGEC	(5) PART NUMBER	(6) DESCRIPTION AND USABLE ON CODE (UOC)	(7) QTY
GROUP 12 ELECTRICAL SYSTEM FIGURE 27 CEILING LIGHT - FIXED						
1	PAOZZ		097M6	F40CW/RS/WM	TUBE, FLUORESCENT.....	2
2	PAOZZ		98775	RC-2SP40-TP	BALLAST, FLUORESCENT LAMP.....	1
3	PAOZZ		39428	1626K31	FILTER, CLEAR.....	2
4	PAOZZ		39428	1626K4RED	FILTER, RED.....	2
NOTE: ITEM 3 OR 4 BY SPECIFIC FIXTURE						
5	PAOZZ		0U5N7	47012311	RETAINER, LIGHT TUBE.....	2
6	PAOZZ		097M6	PS-6000	ASSEMBLY, EMERGENCY LIGHT.....	1
NOTE: ITEM 6 FOR FIXTURE AT PERSONNEL DOOR ONLY						
END OF FIGURE						

CONTAINERIZED KITCHEN (CK)  
GROUP 12 ELECTRICAL SYSTEM REPAIR PARTS

0044 00

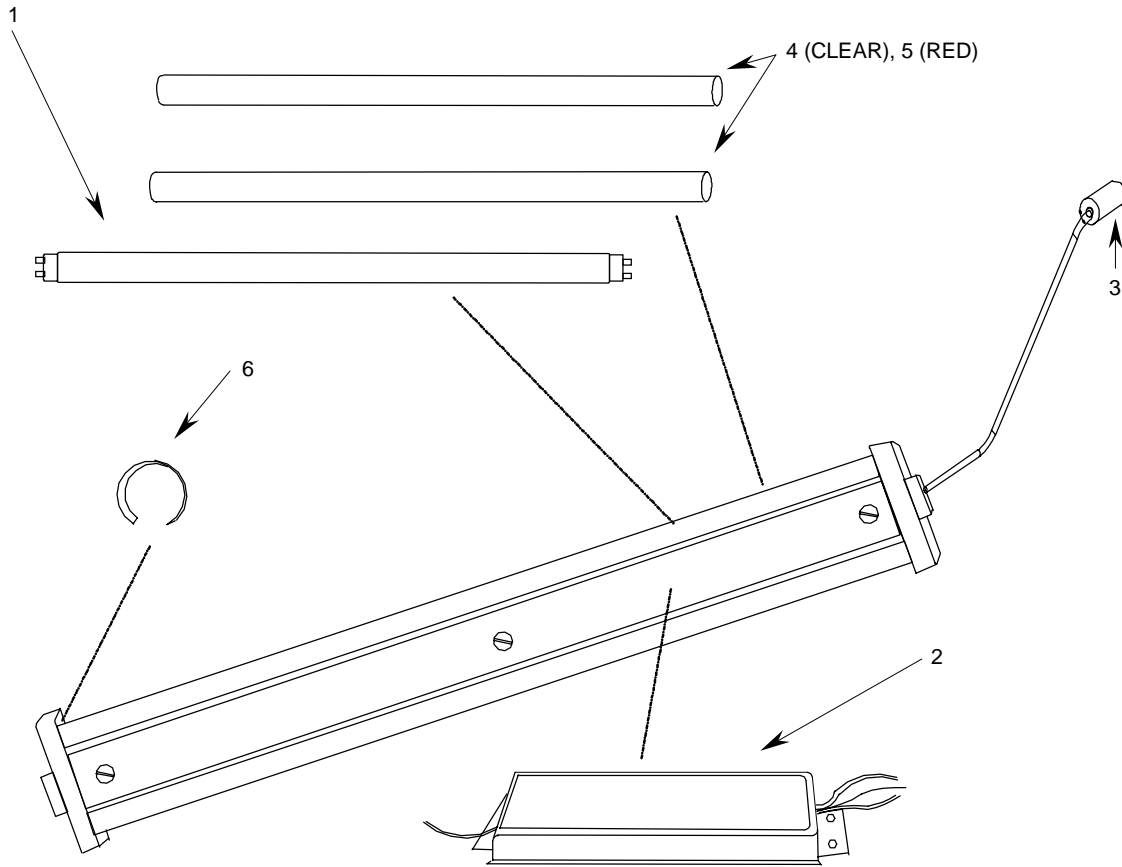

Figure 28. Ceiling Light – Removable.

**CONTAINERIZED KITCHEN (CK)  
GROUP 12 ELECTRICAL SYSTEM REPAIR PARTS**

**0044 00**

(1) ITEM NO.	(2) SMR CODE	(3) NSN	(4) CAGEC	(5) PART NUMBER	(6) DESCRIPTION AND USABLE ON CODE (UOC)	(7) QTY
					GROUP 12 ELECTRICAL SYSTEM FIGURE 28 CEILING LIGHT - REMOVABLE	
1	PAOZZ		097M6	F40CW/RS/WM	TUBE, FLUORESCENT.....	2
2	PAOZZ		98775	RC-2SP40-TP	BALLAST, FLUORESCENT LAMP .....	1
3	PAOZZ		097M6	7594V	PLUG, TWIST-LOC .....	1
4	PAOZZ		39428	1626K31	FILTER, CLEAR .....	2
5	PAOZZ		39428	1626K4RED	FILTER, RED.....	2
					NOTE: ITEM 4 OR 5 BY SPECIFIC FIXTURE	
6	PAOZZ		0U5N7	47012311	RETAINER, LIGHT TUBE.....	2
					END OF FIGURE	

THIS PAGE INTENTIONALLY LEFT BLANK

**CONTAINERIZED KITCHEN (CK)  
GROUP 99 BULK MATERIAL REPAIR PARTS**

**0045 00**

(1) ITEM NO.	(2) SMR CODE	(3) NSN	(4) CAGEC	(5) PART NUMBER	(6) DESCRIPTION AND USABLE ON CODE (UOC)	(7) QTY
					GROUP 99 BULK MATERIAL FIGURE BULK	
1	PAOZZ		097M6	85022	CORD, TYPE SJ00W, 2 CONDUCTOR, 12 AWG (FOR COOK CENTER, OVEN ASSY POWER CABLES).....1	
2	PAOZZ		097M6	RM-WIRE12RED	WIRE, HOOKUP, THHN, 12 AWG RED (FOR COOK CENTER POWER CABLE).....1	
3	PAOZZ		097M6	RM-WIRE12BLK	WIRE, HOOKUP, THHN, 12 AWG BLACK (FOR COOK CENTER POWER CABLE) .....1	
4	PAOZZ		39428	5233K57	TUBING, PVC, 1/4" ID, 7/16" OD, CLEAR (FOR AIR CONDITIONER CONDENSATION DRAIN) ..... 1	
					END OF FIGURE	

THIS PAGE INTENTIONALLY LEFT BLANK

---

**CONTAINERIZED KITCHEN (CK)  
SPECIAL TOOLS LIST**

---

**0046 00**

No special tools are required to maintain the Containerized Kitchen.



THIS PAGE INTENTIONALLY LEFT BLANK

**CONTAINERIZED KITCHEN (CK)  
NATIONAL STOCK NUMBER INDEX**

**0047 00**

<b>STOCK NUMBER</b>	<b>FIG.</b>	<b>ITEM</b>
5935-00-321-8295	10	2
	14	1
5925-00-728-1969	23	7
4730-00-795-6959	9	7
	13	6
5925-00-936-3933	23	4
5925-00-983-5666	23	5
5925-00-984-2163	23	1
5925-01-018-3041	23	2
5925-01-056-5127	23	6
5935-01-116-3615	10	1
	14	2
5340-01-144-2649	9	8
	13	7
2030-01-168-9371	20	3
6210-01-172-5978	24	4
5930-01-174-8604	24	6
5925-01-245-6479	23	3
5925-01-280-0280	25	4
5930-01-289-0884	24	7
5930-01-291-5467	24	3
5925-01-299-1282	25	6
5930-01-302-9739	24	1
5930-01-306-9740	24	5
5930-01-367-5513	24	2

THIS PAGE INTENTIONALLY LEFT BLANK

**CONTAINERIZED KITCHEN (CK)  
PART NUMBER INDEX**

**0048 00**

<b>PART NUMBER</b>	<b>FIG.</b>	<b>ITEM</b>	<b>PART NUMBER</b>	<b>FIG.</b>	<b>ITEM</b>
1450A2119	7	3	47012311	27	5
1452-1531	7	2		28	6
1452-1541	7	1	47013012	15	3
1468A3029	7	4		16	3
1468A3129	7	5	47013014	5	1
1626K31	27	3	47013023	22	3
	28	4	47016030	21	1
1626K4RED	27	4	4C727	12	1
	28	5	4E35Q	8	1
16830-000	16	5	50389214	1	2
17465-000	16	6	50389296	2	1
17963-000	16	4	50389297	2	2
18202-001	16	2	50389298	3	4
18202-002	16	1	50389299	3	2
2088-594-154	19	4		3	5
2150K48	8	3	50389341	3	1
22785T63	19	1	50389344	1	1
	20	1	50390343	3	3
22785T68	19	2	5233K57	BULK	4
	20	2	62215T78	19	13
23605K52	19	3	6226T11	19	12
2370T11	11	1	6226T12	19	11
2370T31	11	2	6815K13	4	3
2773K1	19	6	753-2454	6	2
3891T16	20	3	7594V	25	7
40905	18	2		28	3
	11	2	800-1035	5	2
	19	5	85022	BULK	1
40910	25	3	886-0340	5	3
44X	9	6	9376K113	8	2
	13	5	98812A030	22	6
47011047	21	2	9908T18	17	1
47011050-1	1	3	9908T31	17	2
47011050-2	19	9	9943	17	3
47012152-1	9	1	A128	18	1
47012152-2	13	2	A161802	4	2
	6	4	B03	1	3
47012152-3	9	2		19	10
47012152-4	13	3	B2-H16	9	7
47012152-5	13	1		13	6
47012153-1	9	4	C199-HM2000	15	3
47012153-2	13	4	DPA63-V02	22	1
47012153-3	9	3	DPA-D11	22	2
47012153-4	9	5	F40CW/RS/WM	27	1
47012265	4	1		28	1

**CONTAINERIZED KITCHEN (CK)  
PART NUMBER INDEX**

0048 00

<b>PART NUMBER</b>	<b>FIG.</b>	<b>ITEM</b>	<b>PART NUMBER</b>	<b>FIG.</b>	<b>ITEM</b>
HBL11SP	24	9	ZB2BZ102	24	7
HBL11SP	25	1	ZB2BZ104	24	6
	26	1			
HBL22SP	24	8			
HS13-Z	6	1			
LK-2490	19	8			
M-I-WH6U3SS	19	7			
MS3106F16-11P	10	1			
	13	2			
MS3106F16-11S	10	2			
	13	1			
N3030B	22	5			
PS-6000	27	6			
P-SDC-2-HK	9	8			
	13	7			
QOB110	23	6			
QOB115	23	1			
QOB115GFI	23	2			
QOB210	23	3			
QOB315	23	5			
QOB330	23	7			
QOB360	23	4			
RC-2SP40-TP	27	2			
	28	2			
RM-WIRE12BLK	BULK	3			
RM-WIRE12RED	BULK	2			
RPB5D	15	1			
RPB5NB	15	2			
RPC06-317	15	6			
RPC07-032-23.250	15	7			
RPC13-064	15	9			
RPC13-105	15	8			
RPC13-127	15	4			
RPC13-129	15	5			
SSB1	24	10			
	25	2			
	26	2			
W28XQ1A-1	25	6			
W28XQ1A-2	25	4			
W28XQ1A-6	25	5			
W58-XB4A4A-5	22	4			
ZB2BA2	24	1			
ZB2BT4	24	5			
ZB2BV05	24	4			
ZB2BW061	24	3			
ZB2BW33	24	2			

---

**CONTAINERIZED KITCHEN (CK) 0049 00**  
**COMPONENTS OF END ITEM (COEI) AND BASIC ISSUE ITEMS (BII) LISTS**

---

**INTRODUCTION**

**Scope**

This work package lists the Components of End Item (COEI) and Basic Issue Items (BII) for the CK to help you inventory items for safe and efficient operation of the equipment.

**General**

The COEI and BII information is divided into the following lists:

**Components of End Item (COEI).** This list is for information purposes only and is not authority to requisition replacements. These items are part of the CK. As part of the end item, these items must be with the end item whenever it is issued or transferred between property accounts. Items of COEI are removed and separately packaged for transportation or shipment only when necessary. Illustrations are furnished to help you find and identify the items.

**Basic Issue Items (BII).** These essential items are required to place the CK in operation, operate it, and to do emergency repairs. Although shipped separately packaged, BII must be with the CK during operation and when it is transferred between property accounts. Listing these items is your authority to request/requisition them for replacement based on authorization of the end item by the TOE/MTOE. Illustrations are furnished to help you find and identify the items.

**Explanation of Columns in the COEI List and BII List**

Column (1) – Illus Number. Gives you the number of the item illustrated.

Column (2) – National Stock Number (NSN). Identifies the stock number of the item to be used for requisitioning purposes.

Column (3) – Description, Commercial and Government Entity Code (CAGEC), and Part Number (P/N). Identifies the Federal item name (in all capital letters) followed by a minimum description when needed. The stowage location of COEI and BII is also included in this column. The last line below the description is the CAGEC (in parentheses) and the part number.

Column (4) – Usable On Code. When applicable, gives you a code if the item you need is not the same for different models of equipment.

Column (5) – Unit of Measure (U/M). Indicates the physical measurement or count of the item as issued per the National Stock Number (NSN) shown in column (2).

Column (6) – Qty Rqr. Indicates the quantity required.

**CONTAINERIZED KITCHEN (CK)  
COMPONENTS OF END ITEM AND BASIC ISSUE ITEMS LISTS**

0049 00

**COMPONENTS OF END ITEM (COEI) LIST**

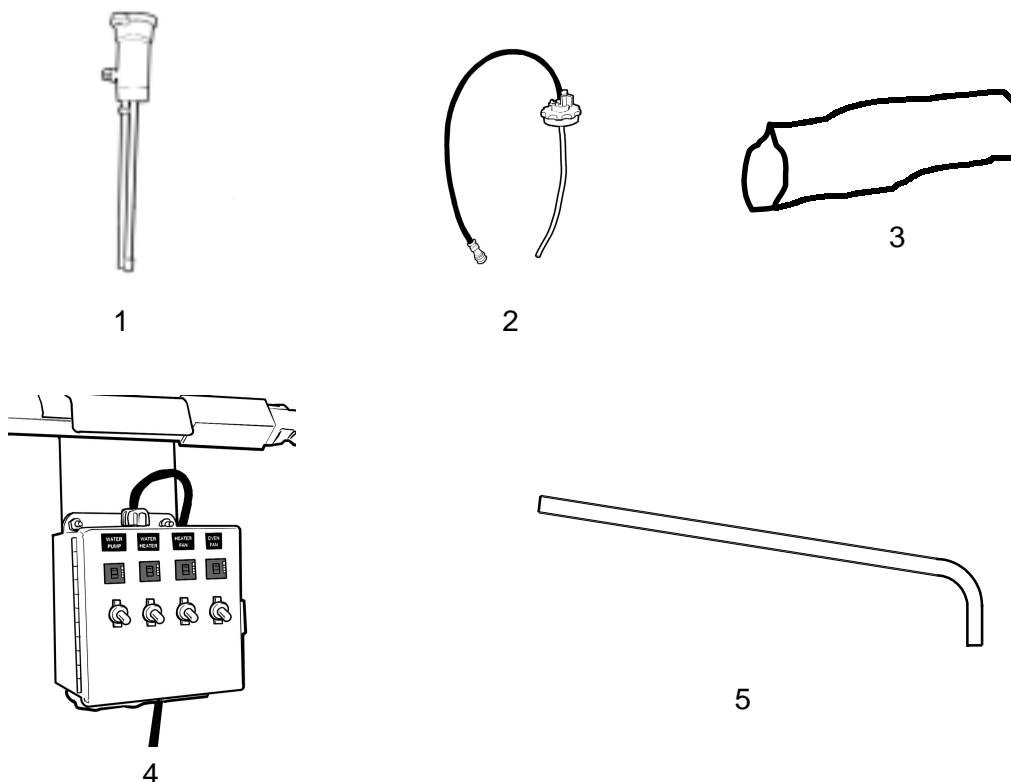
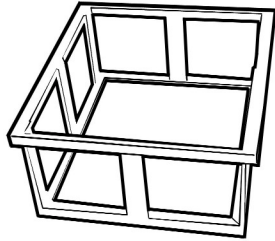

**Table 1. Components of End Item List.**

(1) ILLUS NUMBER	(2) NATIONAL STOCK NUMBER	(3) DESCRIPTION, (CAGEC) AND PART NUMBER	(4) USABLE ON CODE	(5) U/M	(6) QTY RQR
1	2910-00-066-1235	ADAPTER, FUEL, GENERATOR (97403) 13211E7541		EA	1
2	7310-01-455-3736	ADAPTER, FUEL, MBU (3AD06) MS0300		EA	1
3		AIR DISCHARGE DUCT, ECU (0U597) 47012181		EA	1
3		AIR DISCHARGE DUCT, GENERATOR (0U5N7) 47012180		EA	1
3		AIR DISCHARGE DUCT, VENT HOOD (0U5N7) 47012190		EA	1
4		APPLIANCE CONTROL BOX (0U5N7) 47013001		EA	1
5		ARCH, SHELTER (80298) 50389347		EA	10

**CONTAINERIZED KITCHEN (CK)  
COMPONENTS OF END ITEM AND BASIC ISSUE ITEMS LISTS**

0049 00



6

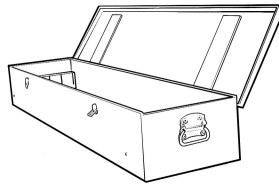

7

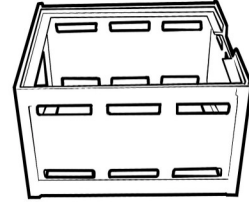

8



9

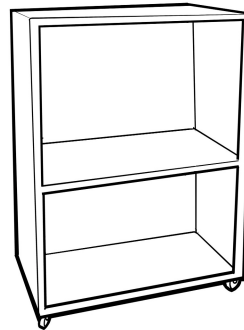

10

**Table 1. Components of End Item List. – Continued.**

(1) ILLUS NUMBER	(2) NATIONAL STOCK NUMBER	(3) DESCRIPTION, (CAGEC) AND PART NUMBER	(4) USABLE ON CODE	(5) U/M	(6) QTY RQR
6		BASE RACK ASSEMBLY (0U5N7) 47016042		EA	1
7		BOX, LIGHT STORAGE (0U5N7) 47011041		EA	1
8		BURNER RACK ASSEMBLY (0U5N7) 47016041		EA	1
9	7310-01-452-8137	BURNER UNIT, MODERN (MBU) (3AD06) MS0001		EA	7
10		CABINET, MOBILE STORAGE (0U5N7) 47012111		EA	2



**CONTAINERIZED KITCHEN (CK)  
COMPONENTS OF END ITEM AND BASIC ISSUE ITEMS LISTS**

0049 00

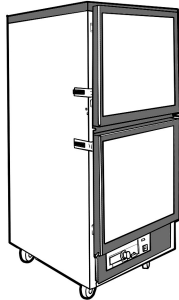

11



12

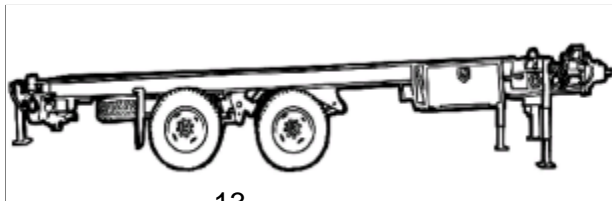

13

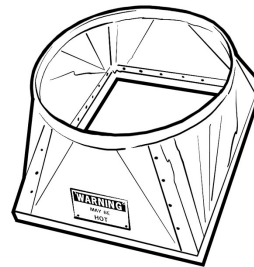

14

**Table 1. Components of End Item List – Continued.**

(1) ILLUS NUMBER	(2) NATIONAL STOCK NUMBER	(3) DESCRIPTION, (CAGEC) AND PART NUMBER	(4) USABLE ON CODE	(5) U/M	(6) QTY RQR
11		CABINET, MOBILE WARMING (0U5N7) 47011063		EA	1
12		CEILING LIGHT, REMOVABLE (0U5N7) 47013003-1		EA	3
12		CEILING LIGHT, REMOVABLE, BLACKOUT (0U5N7) 47013003-2		EA	2
13	2330-01-471-7006	CHASSIS, CONTAINERIZED KITCHEN TRAILER (2W888) 1103-1000-00		EA	1
14		COOK POT CRADLE (0U5N7) 47016040		EA	2

**CONTAINERIZED KITCHEN (CK)  
COMPONENTS OF END ITEM AND BASIC ISSUE ITEMS LISTS**

0049 00



15

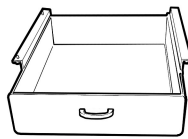

16

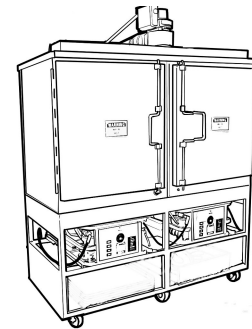

17

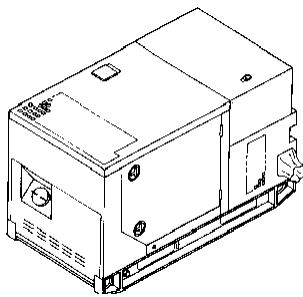

18

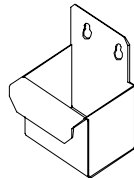

19

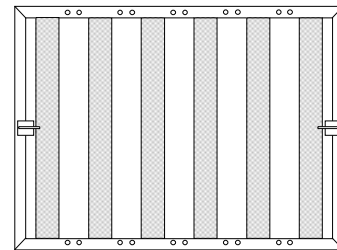

20

**Table 1. Components of End Item List – Continued.**

(1) ILLUS NUMBER	(2) NATIONAL STOCK NUMBER	(3) DESCRIPTION, (CAGEC) AND PART NUMBER	(4) USABLE ON CODE	(5) U/M	(6) QTY RQR
15		COOK POT CRADLE ADAPTER (0U5N7) 47012254		EA	4
16		DRAWER ASSEMBLY (0U5N7) 47011047		EA	2
17		DUAL OVEN ASSEMBLY (0U5N7) 47011043		EA	1
18		GENERATOR, 10 KW TACTICAL QUIET (30554) MEP-803A		EA	1
19		GREASE CUP (0U5N7) 47012124		EA	1
20		GREASE FILTER (26116) KG-2016/21		EA	7

**CONTAINERIZED KITCHEN (CK)  
COMPONENTS OF END ITEM AND BASIC ISSUE ITEMS LISTS**

0049 00

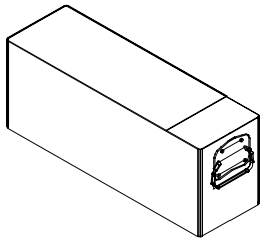

21



22



23



24

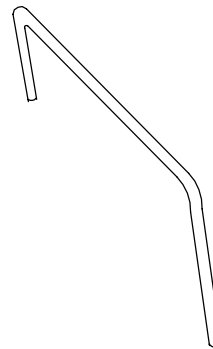

25

**Table 1. Components of End Item List – Continued.**

(1) ILLUS NUMBER	(2) NATIONAL STOCK NUMBER	(3) DESCRIPTION, (CAGEC) AND PART NUMBER	(4) USABLE ON CODE	(5) U/M	(6) QTY RQR
21		GREASE CONTAINER (0U5N7) 47012003		EA	1
22		GRIDDLE ASSEMBLY (0U5N7) 4011035		EA	1
23		HAND SINK ASSEMBLY (0U5N7) 47011028		EA	1
24		HANDLE, JACK/WINCH (80298) 50389298		EA	2
25		HANDRAIL, STAIR (0U5N7) 47012314		EA	6

**CONTAINERIZED KITCHEN (CK)  
COMPONENTS OF END ITEM AND BASIC ISSUE ITEMS LISTS**

0049 00



26

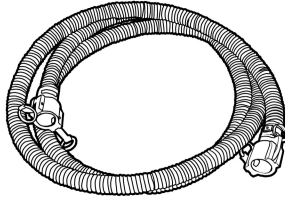

27

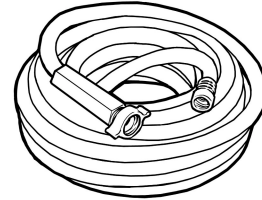

28

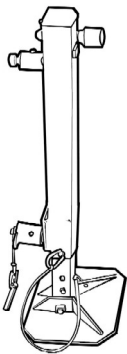

29

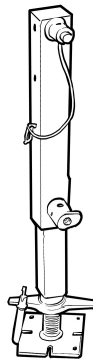

30



31

**Table 1. Components of End Item List – Continued.**

(1) ILLUS NUMBER	(2) NATIONAL STOCK NUMBER	(3) DESCRIPTION, (CAGEC) AND PART NUMBER	(4) USABLE ON CODE	(5) U/M	(6) QTY RQR
26		HEATER, TRAY PACK (OU5N7) 47016035		EA	1
27		HOSE ASSEMBLY, DRAIN, EXTERNAL (OU5N7) 47011050-1		EA	1
27		HOSE ASSEMBLY, DRAIN, INTERNAL (OU5N7) 47011050-2		EA	1
28		HOSE, WATER SUPPLY, 25-ft (39428) 6626T11		EA	2
28		HOSE, WATER SUPPLY, 50-ft (39428) 6626T12		EA	1
29		JACK, CORNER (80298) 50389328		EA	2
30		JACK, SCREW (80298) 50389330		EA	2
31		JACK, WING (80298) 50389327		EA	8

**CONTAINERIZED KITCHEN (CK)  
COMPONENTS OF END ITEM AND BASIC ISSUE ITEMS LISTS**

0049 00



32

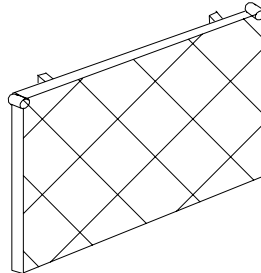

33

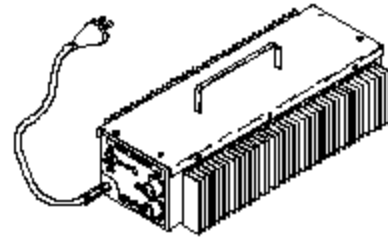

34

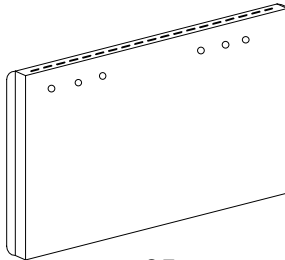

35

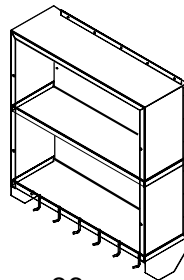

36

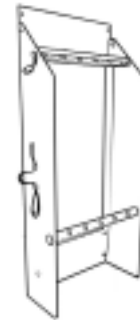

37

**Table 1. Components of End Item List – Continued.**

(1) ILLUS NUMBER	(2) NATIONAL STOCK NUMBER	(3) DESCRIPTION, (CAGEC) AND PART NUMBER	(4) USABLE ON CODE	(5) U/M	(6) QTY RQR
32	6545-00-656-1094	KIT, FIRST AID (04024) 6170-6 TY3		EA	1
33		PLATFORM (0U5N7) 47012320		EA	1
34	7310-01-453-6513	POWER CONVERTER, MBU (3AD06) MS0150		EA	1
35		RACK, KNIFE (0U5N7) 47011075		EA	1
36		RACK, SPICE (0U5N7) 47012239		EA	1
37	8145-01-385-7524	RACK, WEAPONS (80298) 60042002		EA	1

**CONTAINERIZED KITCHEN (CK)  
COMPONENTS OF END ITEM AND BASIC ISSUE ITEMS LISTS**

0049 00

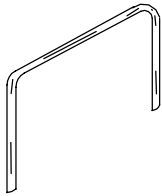

38

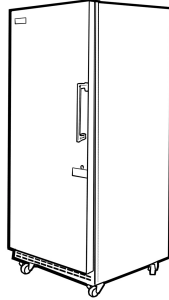

39

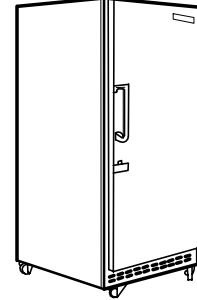

40

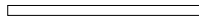

41



42



43

**Table 1. Components of End Item List – Continued.**

(1) ILLUS NUMBER	(2) NATIONAL STOCK NUMBER	(3) DESCRIPTION, (CAGEC) AND PART NUMBER	(4) USABLE ON CODE	(5) U/M	(6) QTY RQR
38		RAIL, PLATFORM (0U5N7) 47012321		EA	1
39		REFRIGERATOR, LEFT HAND (0U5N7) 47011031		EA	1
40		REFRIGERATOR, RIGHT HAND (0U5N7) 47011026		EA	1
41		SPACER, ARCH (80298) 50389350		EA	5
42		SPACER, ARCH, ADJUSTABLE (80298) 50389351		EA	1
43		SPACER, ARCH, CURVED (80298) 50389202		EA	2

**CONTAINERIZED KITCHEN (CK)  
COMPONENTS OF END ITEM AND BASIC ISSUE ITEMS LISTS**

0049 00

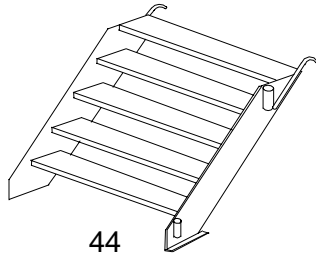

44

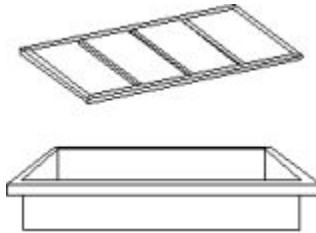

45

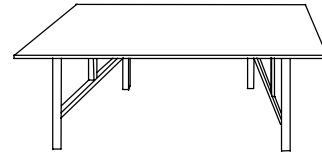

46

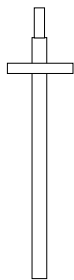

47



48



49

**Table 1. Components of End Item List – Continued.**

(1) ILLUS NUMBER	(2) NATIONAL STOCK NUMBER	(3) DESCRIPTION, (CAGEC) AND PART NUMBER	(4) USABLE ON CODE	(5) U/M	(6) QTY RQR
44		STAIR ASSEMBLY (0U5N7) 47012324		EA	3
45		STEAM TABLE/ADAPTER TOP (0U5N7) 47012144		EA	1
46		TABLE, FIELD, ALTERED (0U5N7) 47011049		EA	4
47		VERTICAL, "X" (80298) 50389353		EA	6
48		VERTICAL, "T", LEFT SIDE (80298) 50389348		EA	2
49		VERTICAL, "T", RIGHT SIDE (80298) 50389349		EA	2

**CONTAINERIZED KITCHEN (CK)  
COMPONENTS OF END ITEM AND BASIC ISSUE ITEMS LISTS**

0049 00

**BASIC ISSUE ITEMS (BII) LIST**

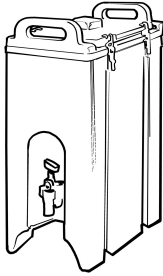

1

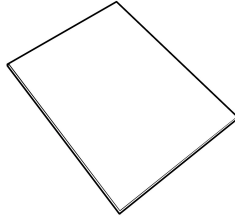

2

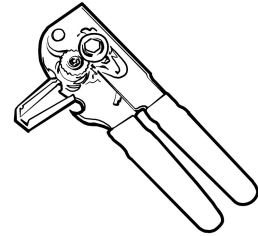

3

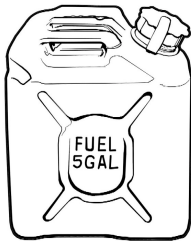

4

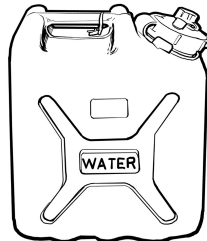

5



6

**Table 2. Basic Issue Items List.**

(1) ILLUS NUMBER	(2) NATIONAL STOCK NUMBER	(3) DESCRIPTION, (CAGEC) AND PART NUMBER	(4) USABLE ON CODE	(5) U/M	(6) QTY RQR
1	7310-01-245-6937	BEVERAGE DISPENSER (58536) A52190-2-2		EA	8
2	7330-00-078-5706	BOARD, FOOD CHOPPING & SLICING (58536) A-A-391		EA	2
3	7330-01-245-0201	CAN OPENER, HAND (81337) 5-13-3971		EA	2
4	7240-01-337-5269	CAN, GASOLINE (81349) MIL-53109		EA	3
5	7240-00-089-3827	CAN, WATER (81349) MIL-C-43613 Type 1		EA	6
6	7330-00-266-7453	COLANDER, STAINLESS STEEL (58536) A-A-469		EA	1



**CONTAINERIZED KITCHEN (CK)  
COMPONENTS OF END ITEM AND BASIC ISSUE ITEMS LISTS**

0049 00

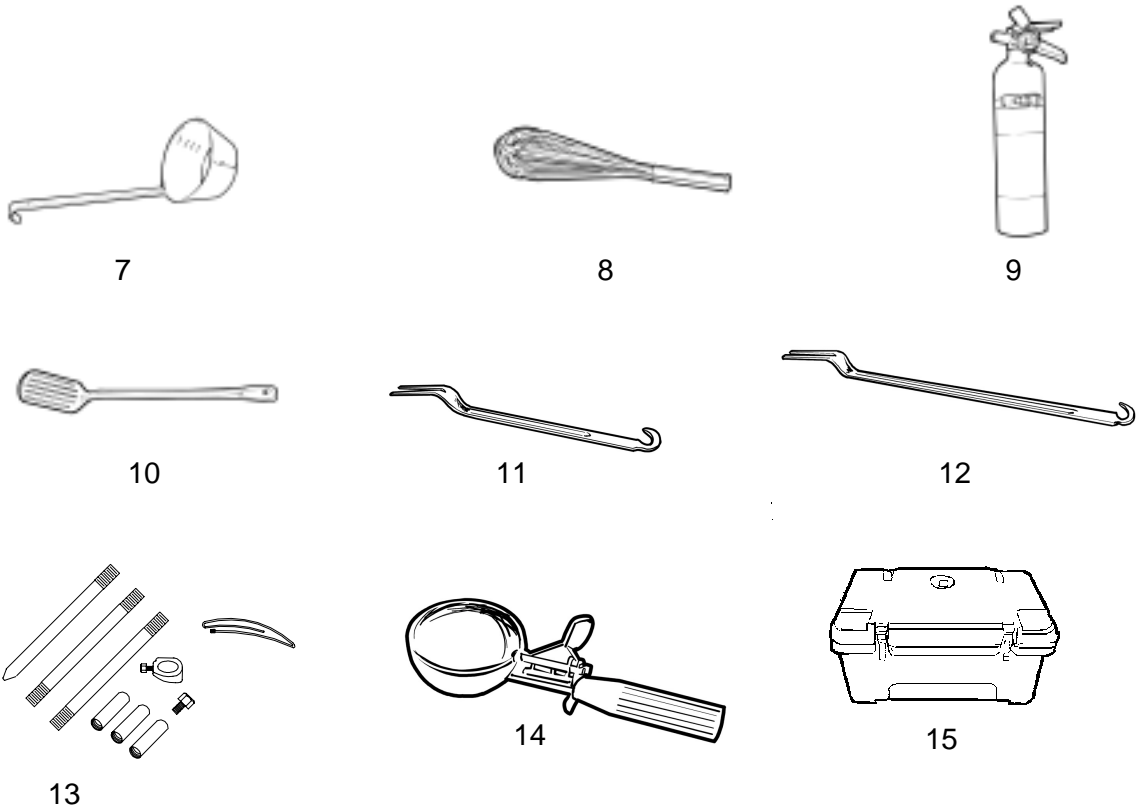
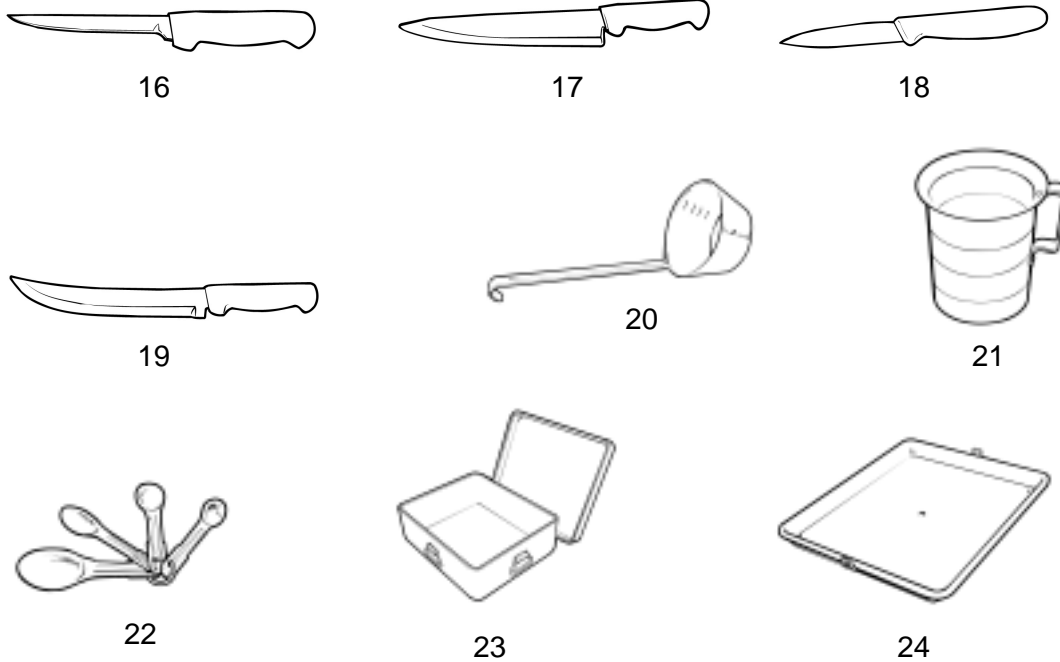

**Table 2. Basic Issue Items List – Continued.**

(1) ILLUS NUMBER	(2) NATIONAL STOCK NUMBER	(3) DESCRIPTION, (CAGEC) AND PART NUMBER	(4) USABLE ON CODE	(5) U/M	(6) QTY RQR
7	7330-00-272-2489	DIPPER, 32 oz. (58536) A-A-1752		EA	4
8	7330-00-815-1458	EGG WHIP (58536) A-A-394		EA	2
9	4210-01-324-5194	FIRE EXTINGUISHER, DRY CHEMICAL (39428) 6487T1		EA	4
10	7330-00-256-2158	FOOD TURNER (58536) A-A-52204		EA	4
11	7340-00-223-7791	FORK, FOOD PREPARATION, 15 in. (58536) A-A-52204		EA	4
12	7340-00-223-7792	FORK, FOOD PREPARATION, 21 in. (58536) A-A-52204		EA	4
13	3820-00-930-6086	GROUND ROD ASSEMBLY (18990) 30162		EA	1
14	7330-00-197-1280	ICE CREAM SCOOP, Size 6 (58536) A-A-43		EA	4
15	7360-01-408-4911	INSULATED FOOD TRANSPORTER (58536) A-A-52193		EA	16

**CONTAINERIZED KITCHEN (CK)  
COMPONENTS OF END ITEM AND BASIC ISSUE ITEMS LISTS**

0049 00

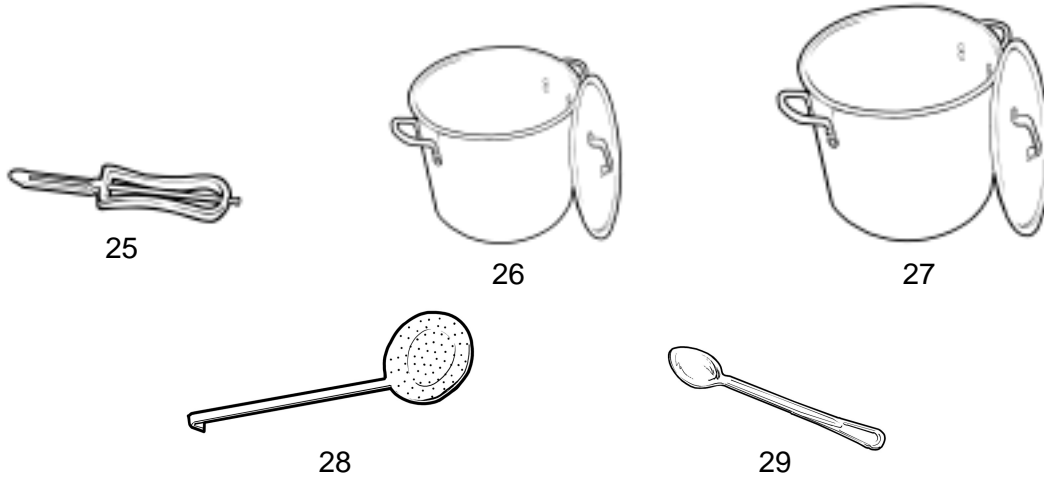

**Table 2. Basic Issue Items List – Continued.**

(1) ILLUS NUMBER	(2) NATIONAL STOCK NUMBER	(3) DESCRIPTION, (CAGEC) AND PART NUMBER	(4) USABLE ON CODE	(5) U/M	(6) QTY RQR
16	7340-00-197-1271	KNIFE, BONING, 10 in. (4Y739) 6447M		EA	3
17	7340-00-488-7950	KNIFE, COOK'S, 10 in. (58536) A-A-2733		EA	3
18	7340-00-488-7939	KNIFE, PARING, 3.25 in. (58536) A-A-2733		EA	4
19	7340-00-197-1274	KNIFE, STEAK, SCIMITAR (58536) A-A-2733		EA	3
20	7330-00-248-1153	LADLE, KITCHEN, 8 oz. (80244)		EA	4
21	7330-00-264-5368	MEASURING CUP, 4 qt. (58536) A-A-1751		EA	2
22	7330-00-272-7876	MEASURING SET, SPOON (80244)		EA	2
23	7330-00-263-8504	PAN, BAKING & ROASTING (58536) A-A-52201		EA	4
24		PAN, BAKING & ROASTING (81349) MIL-P-12851		EA	10

**CONTAINERIZED KITCHEN (CK)  
COMPONENTS OF END ITEM AND BASIC ISSUE ITEMS LISTS**

0049 00

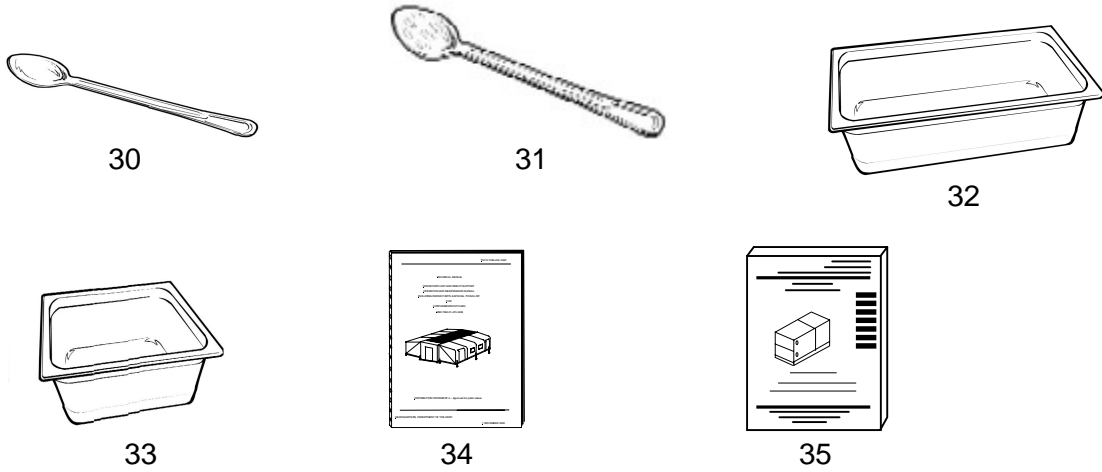

**Table 2. Basic Issue Items List – Continued.**

(1) ILLUS NUMBER	(2) NATIONAL STOCK NUMBER	(3) DESCRIPTION, (CAGEC) AND PART NUMBER	(4) USABLE ON CODE	(5) U/M	(6) QTY RQR
25	7330-00-238-8316	PEELER, POTATO, HAND (85812) W8097		EA	3
26	7330-00-292-2306	POT, COOKING, 10 gal., with Cover (81337) 2-9-35		EA	3
27	7330-00-292-2307	POT, COOKING, 15 gal., with Cover (81337) 2-9-120		EA	3
28	7330-00-680-2635	SKIMMER, KITCHEN (58536) A-A-1072		EA	2
29	7340-00-240-7080	SPOON, FOOD SERVICE, 15 in. (58536) A-A-1082		EA	4

**CONTAINERIZED KITCHEN (CK)  
COMPONENTS OF END ITEM AND BASIC ISSUE ITEMS LISTS**

**0049 00**

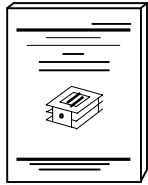

**Table 2. Basic Issue Items List – Continued.**

(1) ILLUS NUMBER	(2) NATIONAL STOCK NUMBER	(3) DESCRIPTION, (CAGEC) AND PART NUMBER	(4) USABLE ON CODE	(5) U/M	(6) QTY RQR
30	7340-00-223-7800	SPOON, FOOD SERVICE, 21 in. (58536) A-A-52204		EA	4
31	7340-00-205-1421	SPOON, FOOD SERVICE, SLOTTED (58536) A-A-1082		EA	4
32		STEAM TABLE PAN, FULL SIZE (0U5N7) 47016028		EA	8
33		STEAM TABLE PAN, HALF SIZE (0U5N7) 47016029		EA	4
34		TECHNICAL MANUAL TM 10-7360-226-13&P		EA	1
35		TECHNICAL MANUAL TM 9-6115-642-10		EA	1

**CONTAINERIZED KITCHEN (CK)  
COMPONENTS OF END ITEM AND BASIC ISSUE ITEMS LISTS**

0049 00



36

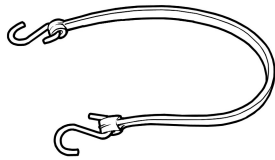

37

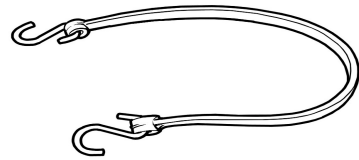

38



39

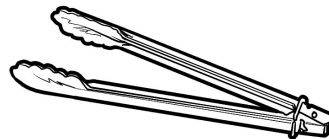

40

**Table 2. Basic Issue Items List – Continued.**

36		TECHNICAL MANUAL TM 10-7310-281-13&P		EA	1
37	2030-01-168-9371	TIE-DOWN, RUBBER, 28 in. (39428) 3891T16		EA	15
38		TIE-DOWN, RUBBER, 35 in. (39428) 3891T19		EA	8
39		TIE-DOWN STRAP, RATCHET (81599) 126-724		EA	19
40	7330-00-616-0997	TONGS, FOOD SERVICE, 12 in. (64067)		EA	4

**CONTAINERIZED KITCHEN (CK)  
ADDITIONAL AUTHORIZATION LIST (AAL)**

**0050 00**

**INTRODUCTION**

**Scope**

This work package lists additional items you are authorized for the support of the CK.

**Explanation of Columns in the AAL**

Column (1) – National Stock Number (NSN). Identifies the stock number of the item to be used for requisitioning purposes.

Column (2) - Description, Commercial and Government Entity Code (CAGEC), and Part Number (P/N). Identifies the Federal item name (in all capital letters) followed by a minimum description when needed. The stowage location of COEI and BII is also included in this column. The last line below the description is the CAGEC (in parentheses) and the part number.

Column (3) - Usable On Code. When applicable, gives you a code if the item you need is not the same for different models of equipment.

Column (4) - Unit of Measure (U/M). Indicates the physical measurement or count of the item as issued per the National Stock Number (NSN) shown in column (1).

Column (5) – Qty Recm. Indicates the quantity recommended.

**ADDITIONAL AUTHORIZATION LIST ITEMS**

**Table 1. Additional Authorization List.**

(1) NATIONAL STOCK NUMBER	(2) DESCRIPTION, (CAGEC) AND PART NUMBER	(3) USABLE ON CODE	(4) U/M	(5) QTY RECM
7310-01-458-5060	EXTENSION CORD, 110 VAC, 25 FT (3AD06) MS0425		EA	2
5120-01-013-1676	SLIDE HAMMER, GROUND ROD (97403) 13226E7741		EA	1

THIS PAGE INTENTIONALLY LEFT BLANK

**CONTAINERIZED KITCHEN (CK)  
EXPENDABLE AND DURABLE ITEMS LIST**

**0051 00**

**INTRODUCTION**

**Scope**

This work package lists expendable and durable items that you will need to operate and maintain the CK. This list is for information only and is not authority to requisition the listed items. These items are authorized to you by CTA 50-970, Expendable/Durable Items (Except Medical, Class V Repair Parts, and Heraldic Items), or CTA 8-100, Army Medical Department Expendable/Durable Items.

**Explanation of Columns in the Expendable and Durable Items List**

Column (1) – Item Number. This number is assigned to the entry in the list and is referenced in the narrative instructions to identify the item (e.g., "Use brake fluid (item 5, WP 0098 00).").

Column (2) – Level. This column identifies the lowest level of maintenance that requires the listed item (C = Operator/Crew).

Column (3) – National Stock Number (NSN). This is the NSN assigned to the item which you can use to requisition it.

Column (4) – Item Name, Description, Commercial and Government Entity Code (CAGEC), and Part Number (P/N). This column provides the other information you need to identify the item.

Column (5) – Unit of Measure (U/M). This code shows the physical measurement or count of an item, such as gallon, dozen, gross, etc.

**EXPENDABLE AND DURABLE ITEMS LIST**

**Table 1. Expendable and Durable Items List.**

(1) ITEM NO.	(2) LEVEL	(3) NSN	(4) ITEM NAME, DESCRIPTION, (CAGEC), PART NUMBER	(5) U/M
1	C		BLANKET, PACKING (39428) 2256T11	EA
2	C	7920-01-338-3329	CLOTH, CLEANING (21994) TX-1250	BG
3	C		COMPOUND, PIPE JOINT (53472) 31226	EA
4	C	9150-01-197-7690	GREASE, AUTOMOTIVE (81349) M-10924-C	CN
5	C	6850-01-265-3115	LUBRICANT, SILICONE (10136) 03030	EA
6	C	9150-01-152-4117	LUBRICATING OIL, ENGINE (81349) MIL-L-2104, OEA HDO 15/40	QT
7	C		KIT, FABRIC REPAIR (80298) 50389342	EA
8	C		TIE, HOOK AND LOOP, 6-INCH (PACK OF 10) (39428) 6605K12	EA
9	C		TIE, HOOK AND LOOP, 8-INCH (PACK OF 10) (39428) 6605K11	EA



THIS PAGE INTENTIONALLY LEFT BLANK

---

**CONTAINERIZED KITCHEN (CK)  
TOOL IDENTIFICATION LIST**

---

**0052 00**

**INTRODUCTION**

**Scope**

This work package lists all common tools and supplements and special tools/fixtures needed to maintain the CK.

**Explanation of Columns in the Tool Identification List**

Column (1) – Item Number. This number is assigned to the entry in the list and is referenced in the initial setup to identify the item (e.g., Extractor (item 32, WP 0090 00)).

Column (2) – Item Name. This column lists the item by noun nomenclature and other descriptive features (e.g., Gage, belt tension).

Column (3) – National Stock Number. This is the National Stock Number (NSN) assigned to the item; use it to requisition the item.

Column (4) – Part Number. Indicates the primary number used by the manufacturer (individual, company, firm, corporation, or Government activity) which controls the design and characteristics of the item by means of its engineering drawings, specifications, standards, and inspection requirements to identify an item or range of items.

Column (5) – Reference. This column identifies the authorizing supply catalog or RPSTL for items listed in this work package.

**TOOL IDENTIFICATION LIST**

**Table 1. Tool Identification List.**

(1) ITEM NO.	(2) ITEM NAME	(3) NATIONAL STOCK NUMBER	(4) PART NUMBER	(5) REFERENCE
1	TOOL KIT, GENERAL MECHANIC'S (GMTK)	5180-01-454-3787	12B470000	SC 5180-95-B47
2	SHOP EQUIPMENT, WELDING	4940-01-090-1231	11022000	

THIS PAGE INTENTIONALLY LEFT BLANK

---

**CONTAINERIZED KITCHEN (CK)  
MANDATORY REPLACEMENT PARTS**

---

**0053 00**

Refer to TM 10-7310-281-13&P for mandatory replacement parts for the MBUs.

The only mandatory replacement part for the generator is the oil filter. Refer to LO 9-6115-642-12 for replacement information and procedure.

There are no mandatory replacement parts for any other components of the CK.

There are no mandatory replacement parts for the CK trailer.

THIS PAGE INTENTIONALLY LEFT BLANK

---

**CONTAINERIZED KITCHEN (CK)  
WIRING DIAGRAMS**

---

**0054 00**

**INTRODUCTION**

**Scope**

This work package describes the wiring provisions contained in the Containerized Kitchen (CK), including all systems or equipment which can be installed or removed later. Wiring diagrams and essential wiring information are provided for all electrical systems and circuits. All critical wire and cable data has been included.

**WIRE IDENTIFICATION**

All wires have been identified by number and/or color. A tabular list of circuit designators and wire identification diagrams is included.

**ABBREVIATIONS**

All abbreviations are in accordance with ASME-Y14.38M, except where the abbreviation stands for a marking actually found in the CK.

**WIRING DIAGRAMS**

Wiring diagrams are included for all electrical systems and circuits.

CONTAINERIZED KITCHEN (CK)  
WIRING DIAGRAMS

0054 00

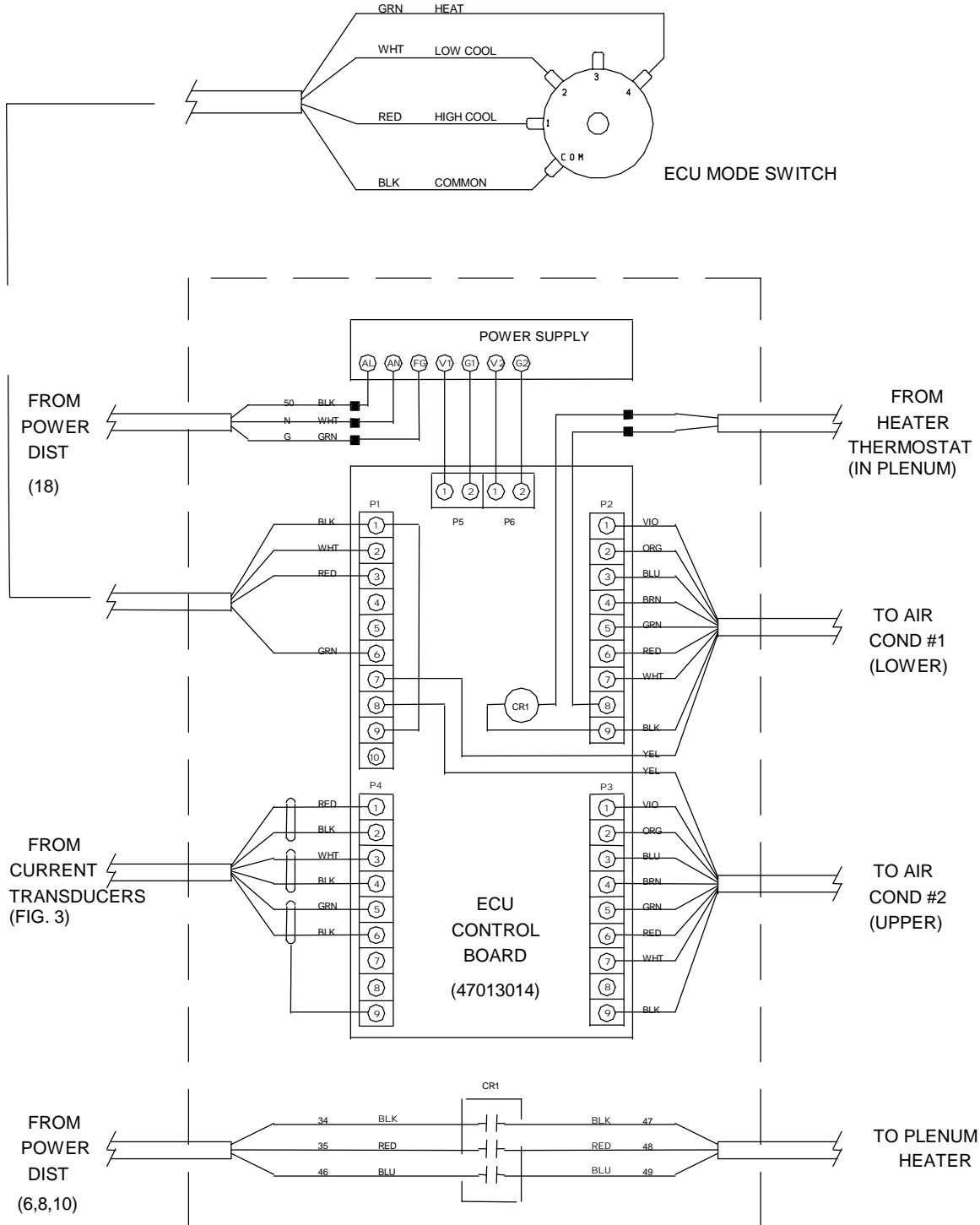
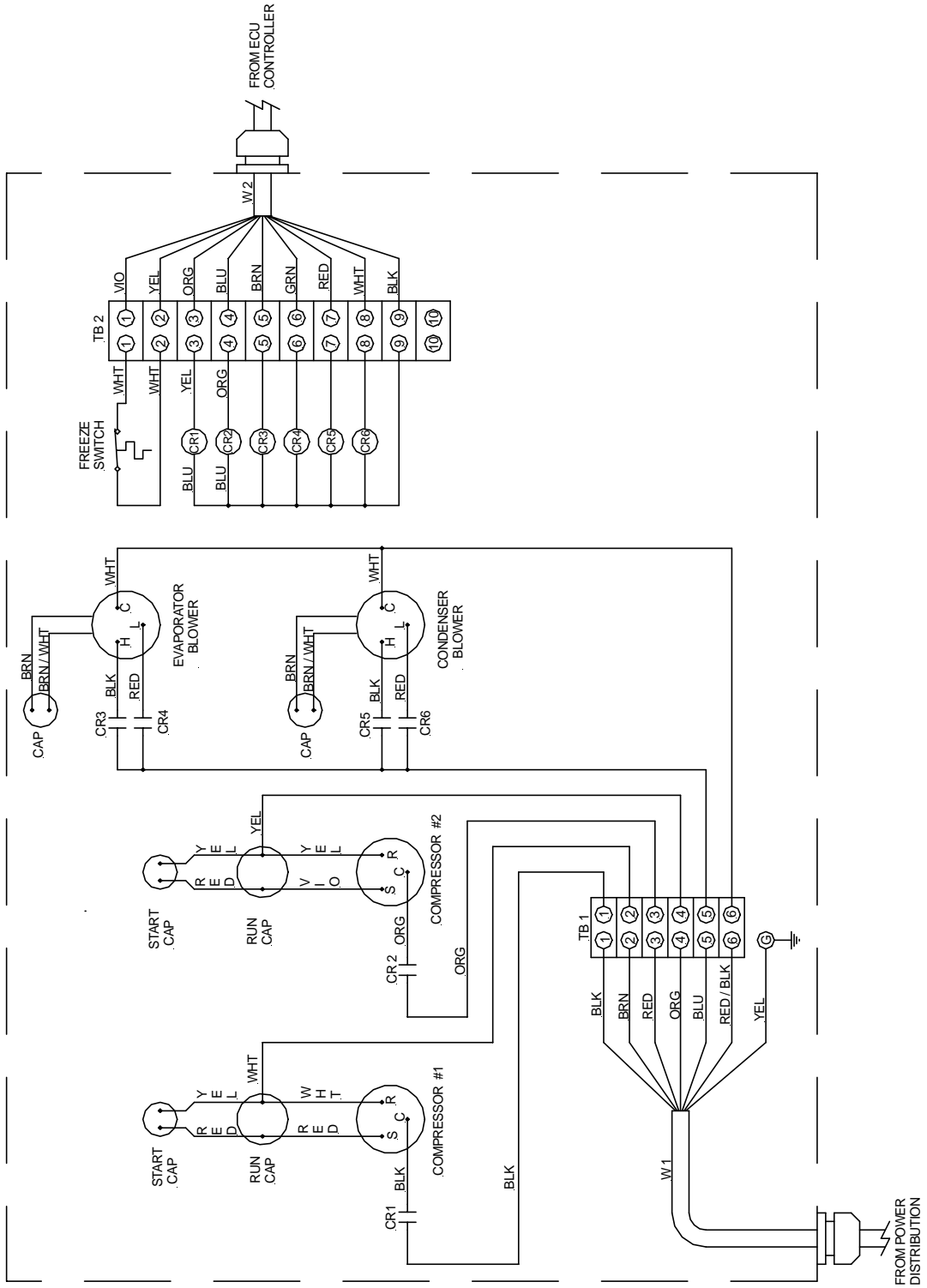

Figure 1. Wiring Diagram, ECU Controller.

**CONTAINERIZED KITCHEN (CK)  
WIRING DIAGRAMS**

**0054 00**



**Figure 2. Wiring Diagram, ECU A/C Primary.**



CONTAINERIZED KITCHEN (CK)  
WIRING DIAGRAMS

0054 00

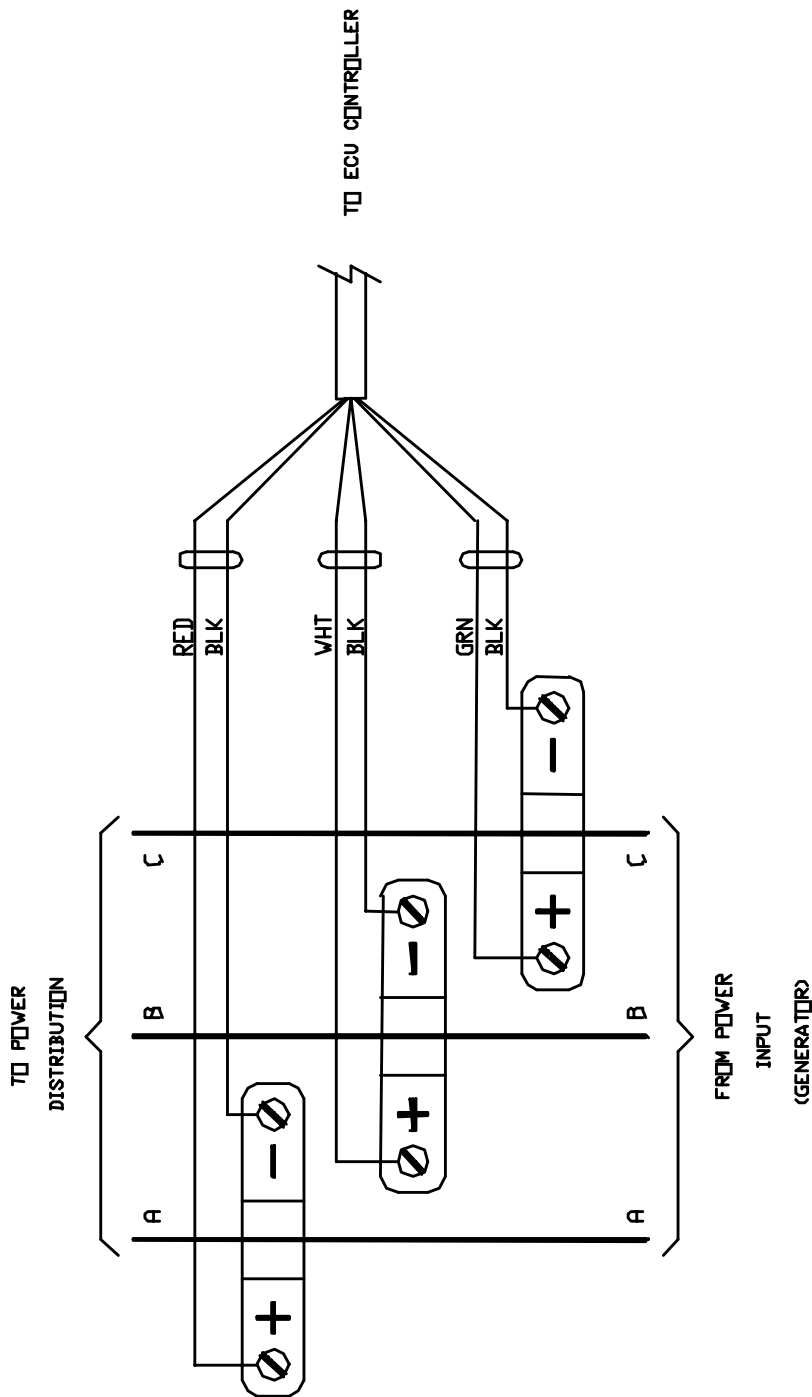

Figure 3. Wiring Diagram, Current Transducer.

CONTAINERIZED KITCHEN (CK)  
WIRING DIAGRAMS

0054 00

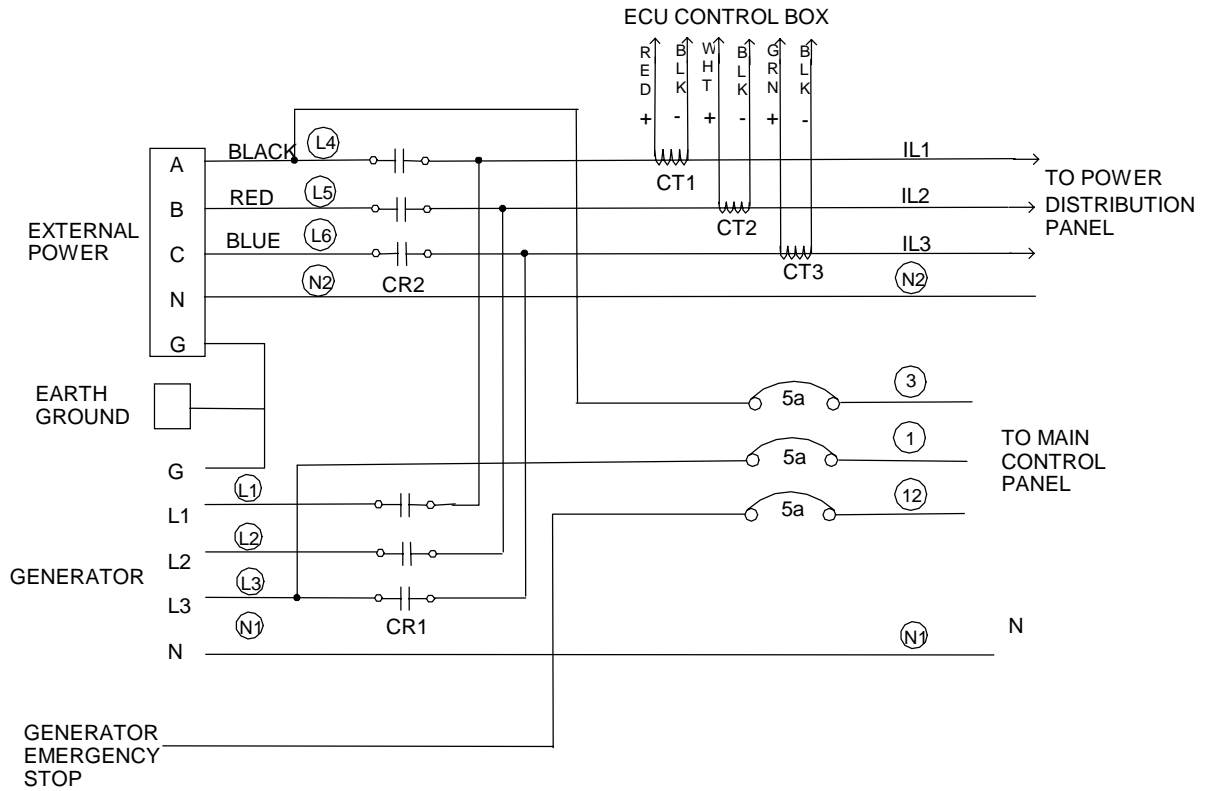
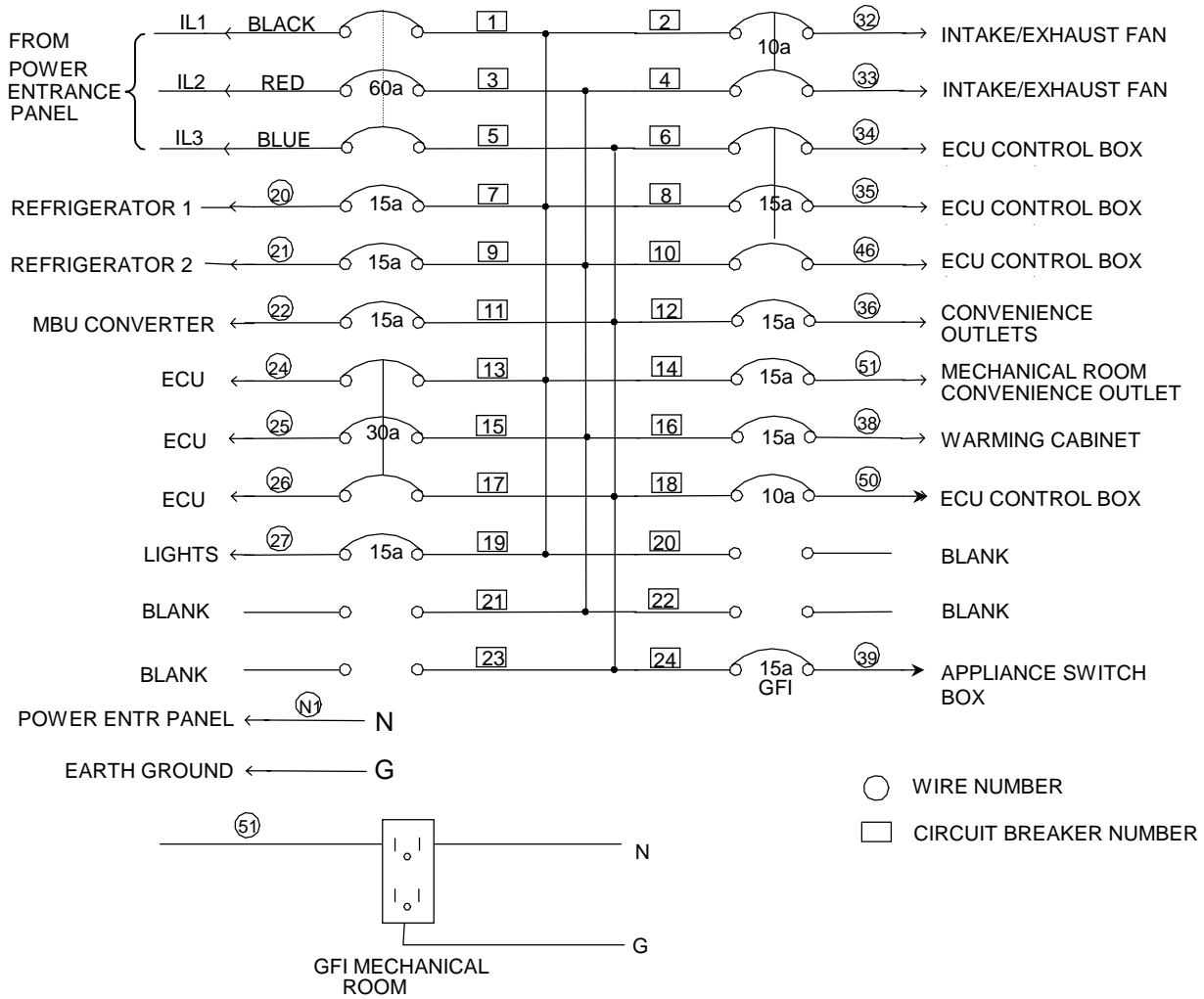

Figure 4. Wiring Diagram, Power Entrance Panel.

**CONTAINERIZED KITCHEN (CK)  
WIRING DIAGRAMS**

**0054 00**



**Figure 5. Wiring Diagram, Power Distribution Panel.**

**CONTAINERIZED KITCHEN (CK)  
WIRING DIAGRAMS**

0054 00

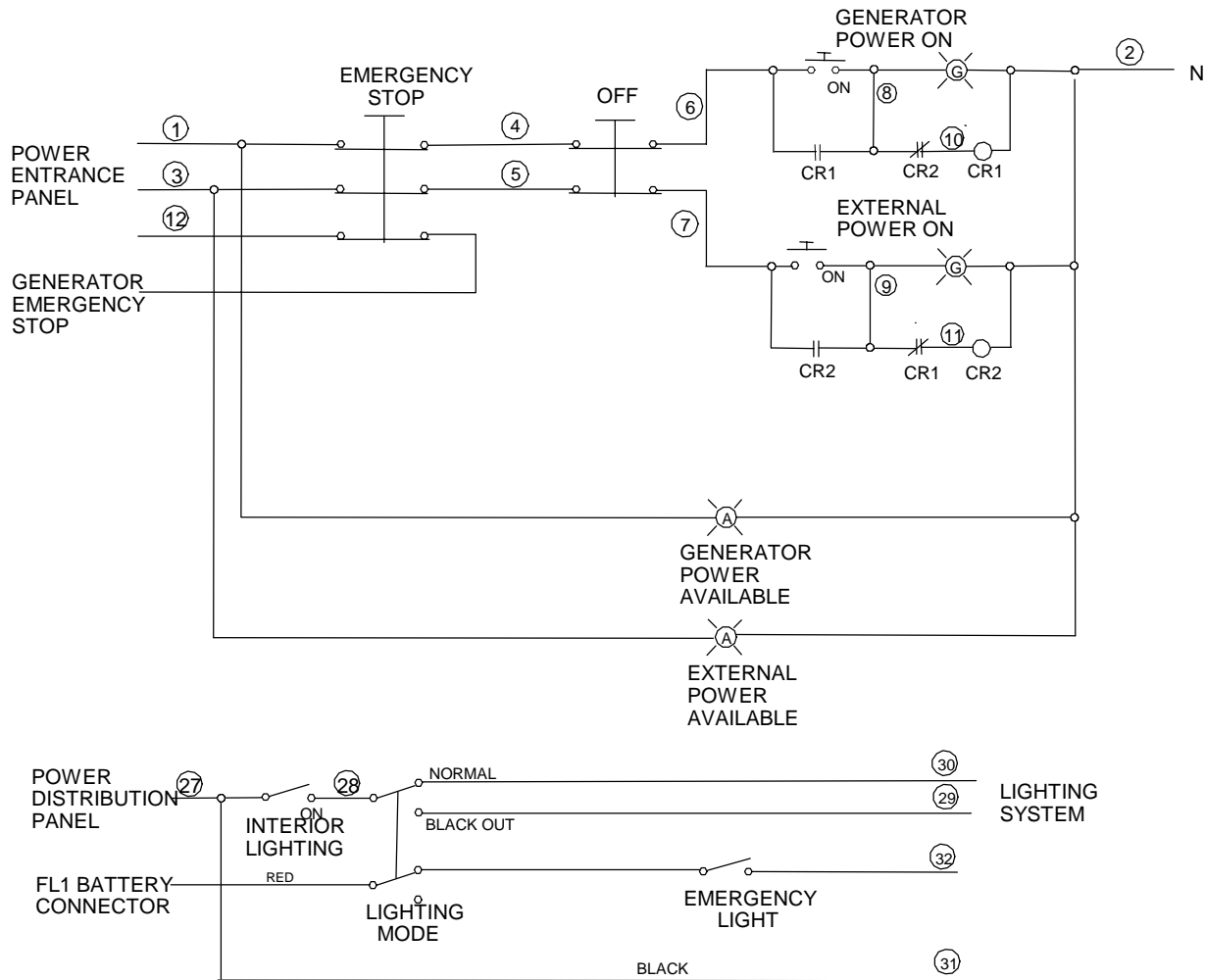

**Figure 6. Wiring Diagram, Main Control Panel.**

CONTAINERIZED KITCHEN (CK)  
WIRING DIAGRAMS

0054 00

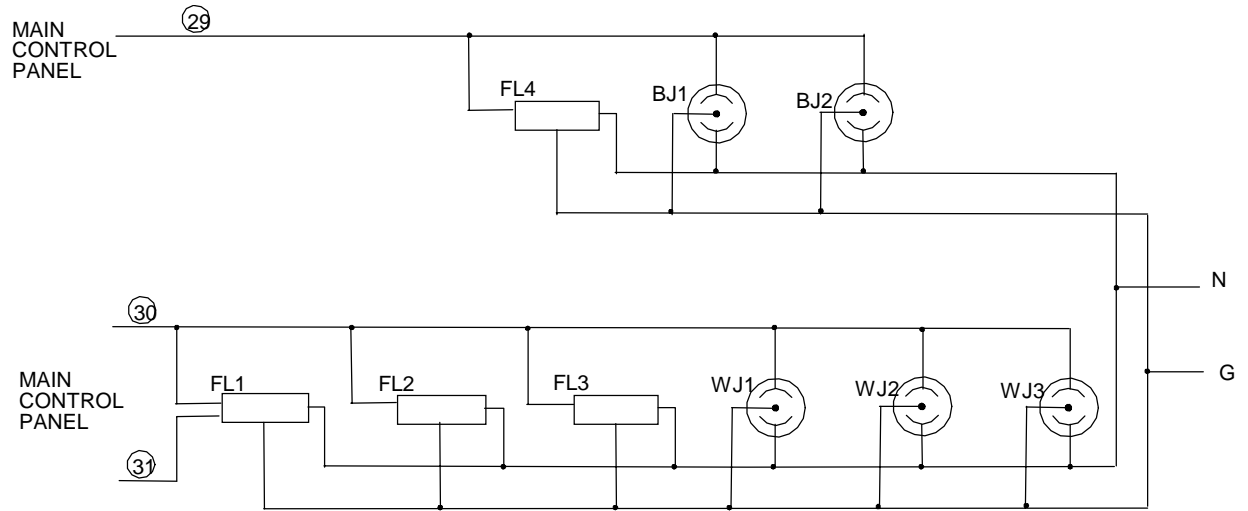
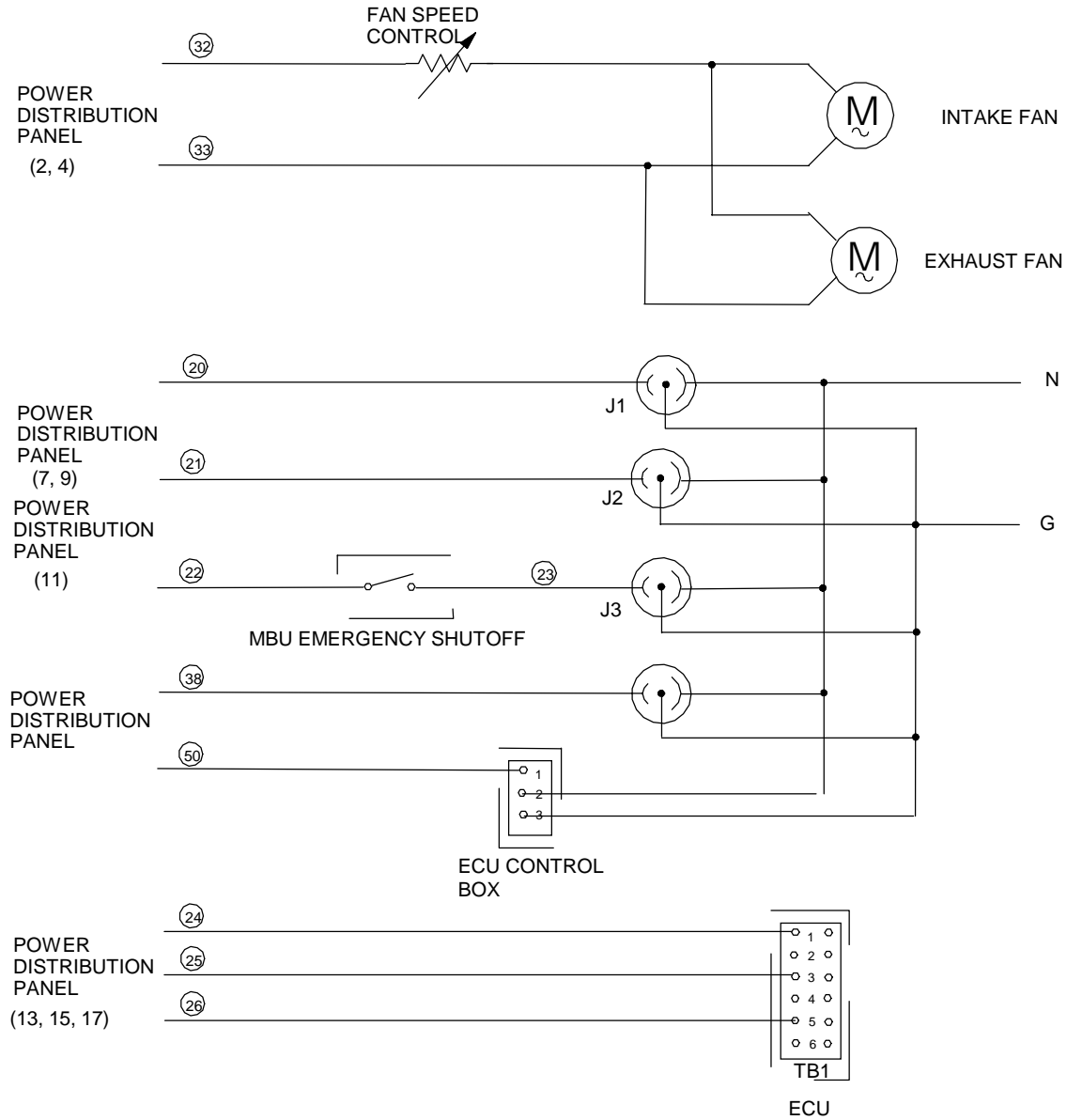

Figure 7. Wiring Diagram, Lighting System.

**CONTAINERIZED KITCHEN (CK)  
WIRING DIAGRAMS**

0054 00



**Figure 8. Wiring Diagram, Miscellaneous Circuits.**

**CONTAINERIZED KITCHEN (CK)  
WIRING DIAGRAMS**

0054 00

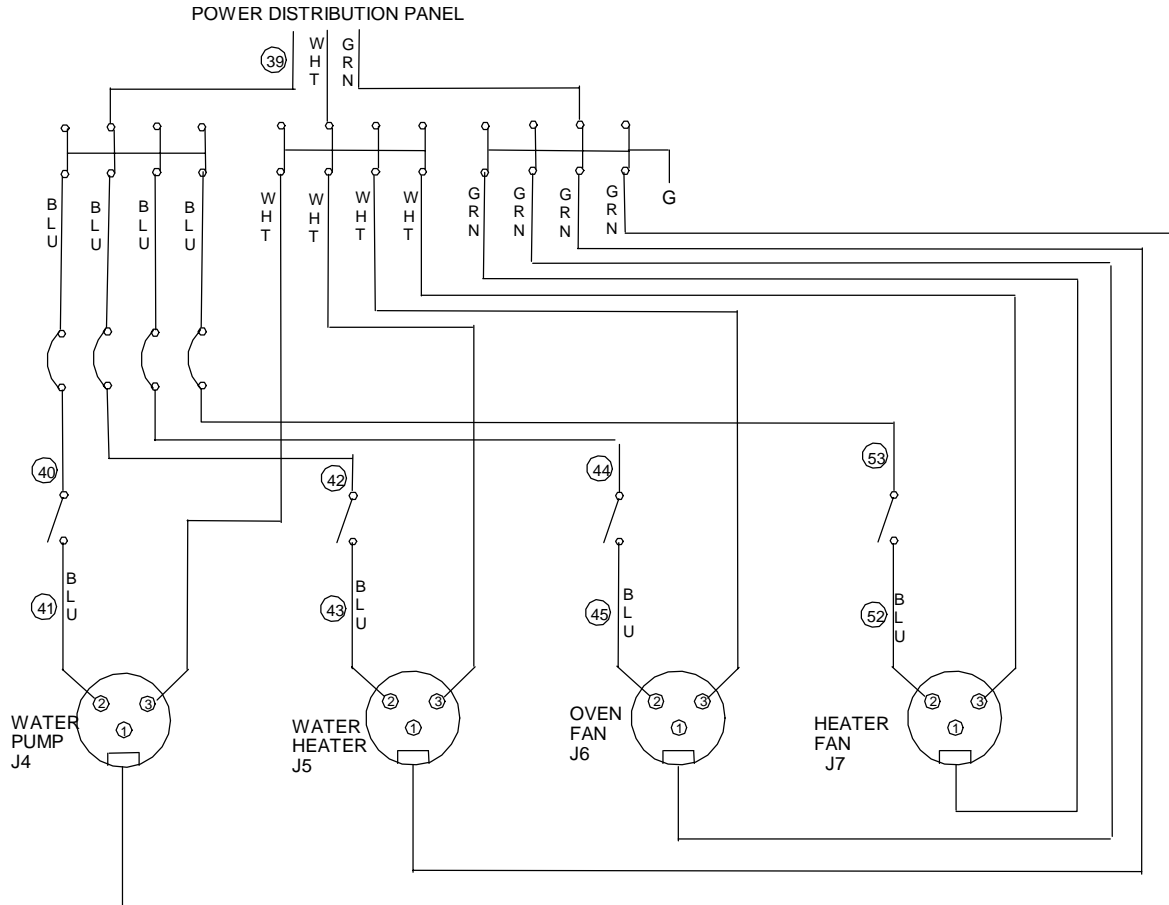

**Figure 9. Wiring Diagram, Appliance Control Box.**

---

**CONTAINERIZED KITCHEN (CK)  
APPENDIX A - TRAILER OPERATIONS**

---

0055 00

**INTRODUCTION**

The CK can be transported and deployed either mounted on, or separate from, its trailer (Chassis, Containerized Kitchen Trailer: 7½ Ton, 4-wheel XCK2000, NSN 2330-01-471-7006). The procedures for setting up, operating, and packing out the CK in either configuration are found in WP 0006 00. This Appendix provides instructions for mounting the CK on, and removing it from, the trailer. Refer to TM 9-2330-328-14&P for information about the trailer.

**GENERAL INFORMATION**

The CK container (Figure 1) is an 8-ft by 8-ft by 20-ft (2.44-m by 2.44-m by 6.1-m) International Organization for Standardization (ISO) container. The packed-out CK weighs approximately 14,080 lbs (6342 kg). It will normally be lifted using a Rough Terrain Container/Cargo Handler (RTCH) or a crane. Slots in the bottom edge of the container also allow it to be lifted using a fork lift with a capacity of at least 18,000 lbs (8172 kg). Since the container's center of gravity is not in the middle (the end with the double doors is heavier than the other end), only the outer pair of slots should be used to ensure stability when using a fork lift.

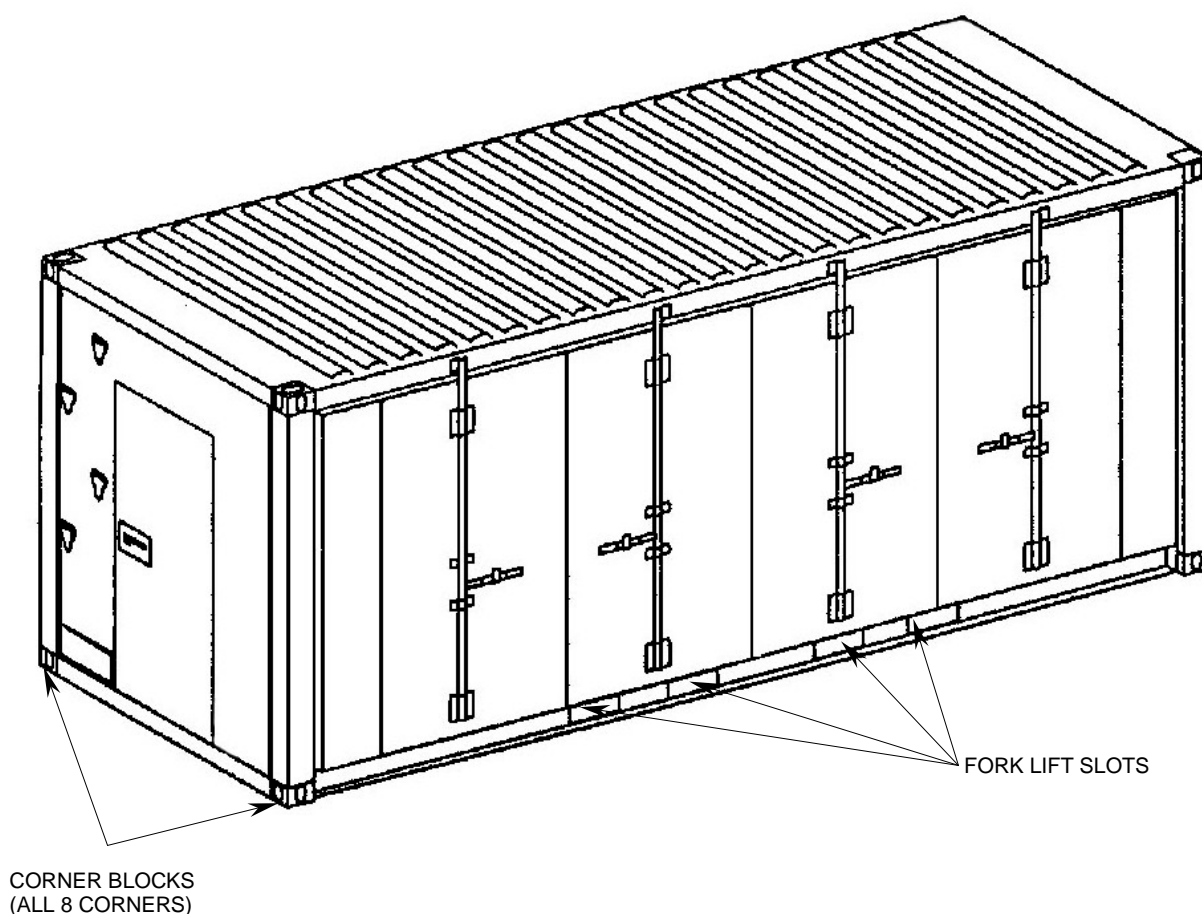

Figure 1. CK Container.

0055 00-1



---

**CONTAINERIZED KITCHEN (CK)  
APPENDIX A - TRAILER OPERATIONS**

---

0055 00

Corner blocks on each of the top corners provide attachment points for lifting the container with an RTCH or crane. Identical blocks on the bottom corners are engaged by ISO locks on the trailer (see Figure 2) to secure the container in place.

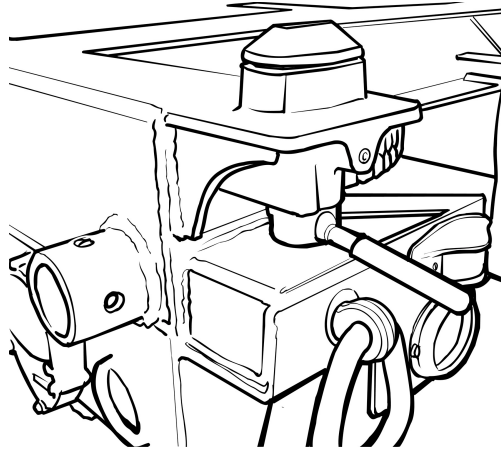

Figure 2. ISO Lock (shown unlocked).

**MOUNTING THE CK ON THE TRAILER****CAUTION**

**When shipping by standard flatbed trailer, the CK must be dismantled from its trailer and each should be shipped separately due to the combined height of the system. Under no circumstances shall the CK and its trailer be shipped on the same trailer.**

1. Ensure that the four ISO locks on the corners of the trailer are unlocked (handles pointing outward from the sides of the trailer). See Figure 2.

**WARNING**

**The CK weighs approximately 14,080 lbs (6342 kg). To avoid death or serious injury, all personnel must stand clear while the container is lifted and placed on the trailer.**

**CAUTION**

**To avoid exceeding the trailer's design tongue weight, position the CK so the end with single door is to the front of the trailer.**

2. Lift the CK and place it on the trailer. See Figure 3. Ensure that the container rests flat on the trailer and the corner blocks are positioned over the ISO locks.
3. Engage the ISO locks by turning them 90 degrees in either direction.
4. If desired, level the trailer as described in WP 0006 00.

---

**CONTAINERIZED KITCHEN (CK)  
APPENDIX A - TRAILER OPERATIONS**

---

0055 00

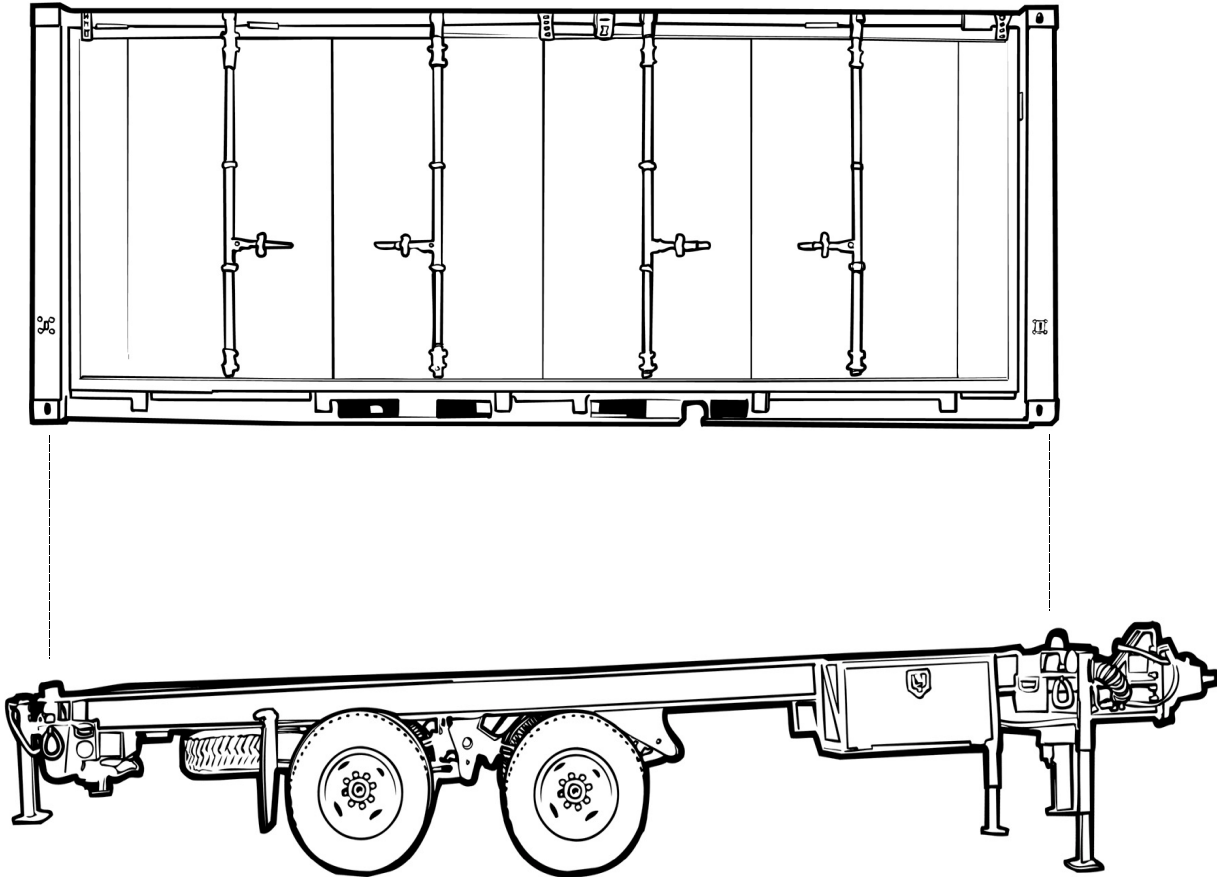

Figure 3. Mounting the CK on the Trailer.

**REMOVING THE CK FROM THE TRAILER**

1. Unlock the four ISO locks on the corners of the trailer by rotating the locking handles 90 degrees so the handles point outward from the sides of the trailer.

---

**CONTAINERIZED KITCHEN (CK)  
APPENDIX A - TRAILER OPERATIONS**

**0055 00**

---

**WARNING**

**The CK weighs approximately 14,080 lbs (6342 kg). To avoid death or serious injury, all personnel must stand clear while the container is lifted and removed from the trailer.**

2. Lift the CK and remove it from the trailer using an RTCH, crane, or fork lift.

END OF WORK PACKAGE

---

**CONTAINERIZED KITCHEN (CK)  
ALPHABETICAL INDEX**

---

<u>Subject</u>	<u>WP Sequence No. – Page No.</u>
<b>A</b>	
Abbreviations and Acronyms.....	0001 00-3
Additional Authorization List.....	0050 00-1
Adverse Weather Conditions.....	0007 00-1
After Operation PMCS .....	0016 00-9
Appliance and Equipment Relocation.....	0006 00-17
Assembly and Preparation for Use.....	0006 00-1
<b>B</b>	
Basic Issue Items (BII) List.....	0049 00-11
Before Operation PMCS .....	0016 00-3
Bulk Material Repair Parts List .....	0045 00-1
<b>C</b>	
Ceiling Light Installation .....	0006 00-21
Common Tools and Equipment.....	0004 00-1
Components of End Item (COEI) List.....	0049 00-2
Cook Center Repair Parts .....	0036 00-1
Corrosion Prevention and Control.....	0001 00-2
<b>D</b>	
Destruction of Army Materiel to Prevent Enemy Use.....	0001 00-2
Difference Between Models .....	0002 00-15
Direct Support Maintenance Procedures – Dual Oven Assembly.....	0028 00-1
Direct Support Maintenance Procedures – Shelter Assembly/Mechanical Room.....	0030 00-1
Direct Support Maintenance Procedures – Cook Center .....	0027 00-1
Direct Support Maintenance Procedures – Tray Pack Heater ..	0029 00-1
Dual Oven Assembly Repair Parts.....	0037 00-1
During Operation PMCS .....	0016 00-7
<b>E</b>	
Electrical System Repair Parts.....	0044 00-1
Emergency Procedures.....	0007 00-4
Energizing the CK from External Power .....	0006 00-16
Energizing the CK from the Onboard Generator.....	0006 00-15
Equipment Characteristics, Capabilities and Features .....	0002 00-1
Equipment Data .....	0002 00-15
Equipment Improvement Recommendations.....	0001 00-2
Equipment Packout.....	0006 00-28
Expendable and Durable Items List.....	0051 00-1

---

**CONTAINERIZED KITCHEN (CK)  
ALPHABETICAL INDEX**

---

<u>Subject</u>	<u>WP Sequence No. – Page No.</u>
<b>F</b>	
Fabric Erection – Food Preparation Wing.....	0006 00-11
Fabric Erection – Serving Wing.....	0006 00-7
Fording and Swimming .....	0007 00-3
<b>G</b>	
General Information .....	0001 00-1
Grounding .....	0006 00-14
<b>H</b>	
Hand Sink Assembly Repair Parts .....	0041 00-1
<b>I</b>	
Interim NBC Decontamination Procedures.....	0007 00-3
<b>J</b>	
Jamming and Electronic Countermeasures.....	0007 00-3
<b>K</b>	
Kitchen Operation .....	0006 00-23
<b>L</b>	
Leveling the Container on the Ground.....	0006 00-2
Leveling the Container on the Trailer .....	0006 00-5
Location and Description of Major Components.....	0002 00-3
<b>M</b>	
Maintenance Allocation Chart (MAC) .....	0032 00-5
Maintenance Forms, Records and Reports .....	0001 00-2
Malfunction/Symptom Index.....	0009 00-1
Mandatory Replacement Parts.....	0053 00-1
Mechanical Room Packout.....	0006 00-34
Mechanical Room Repair Parts.....	0035 00-1
Mechanical Room Setup .....	0006 00-12
Mobile Storage Cabinet Repair Parts .....	0042 00-1
Mobile Warming Cabinet Repair Parts .....	0038 00-1
<b>N</b>	
National Stock Number Index.....	0047 00-1
Nomenclature Cross-Reference List .....	0001 00-3
Nuclear Hardness .....	0001 00-4

---

**CONTAINERIZED KITCHEN (CK)  
ALPHABETICAL INDEX**

---

<u>Subject</u>	<u>WP Sequence No. – Page No.</u>
<b>O</b>	
Operation Under Unusual Conditions.....	0007 00-1
Operation Under Usual Conditions.....	0006 00-1
Operator Controls and Indicators .....	0005 00-1
Appliance Control Box .....	0005 00-7
Cook Center Ventilation.....	0005 00-8
Environmental Control Unit (ECU) .....	0005 00-10
Main Control Panel.....	0005 00-3
MBU Control Panel.....	0005 00-6
MBU Converter.....	0005 00-5
MBU Shutoff Switch.....	0005 00-4
Mobile Warming Cabinet .....	0005 00-9
Power Distribution Panel .....	0005 00-2
Power Entrance Panel.....	0005 00-1
Refrigerator .....	0005 00-10
<b>P</b>	
Packout and Preparation for Transport .....	0006 00-24
Part Number Index.....	0048 00-1
Platform Installation .....	0006 00-14
PMCS – Introduction.....	0016 00-1
Prep/Serving Table Repair Parts.....	0043 00-1
Preparation for Packout .....	0006 00-25
Preparation for Storage and Shipment.....	0001 00-2
<b>R</b>	
References .....	0031 00-1
Refrigerator Repair Parts .....	0039 00-1
Repair Parts.....	0004 00-1
Repair Parts & Special Tools List.....	0033 00-1
<b>S</b>	
Scope of manual.....	0001 00-1
Service Upon Receipt .....	0015 00-1
Shelter Deployment .....	0006 00-2
Shelter Expansion.....	0006 00-5
Shelter Repair Parts.....	0034 00-1
Site Requirements .....	0006 00-1
Special Tools List.....	0045 00-1
Special Tools, TMDE, and Support Equipment .....	0004 00-1

---

**CONTAINERIZED KITCHEN (CK)  
ALPHABETICAL INDEX**

---

<u>Subject</u>	<u>WP Sequence No. – Page No.</u>
<b>T</b>	
Theory of Operation .....	0003 00-1
Tool Identification List .....	0052 00-1
Tools and Test Equipment .....	0032 00-9
Trailer Operations .....	0055 00-1
Tray Pack Heater Repair Parts .....	0040 00-1
Troubleshooting Procedures – Electrical .....	0010 00-1
Troubleshooting Procedures – Environmental Control .....	0012 00-1
Troubleshooting Procedures – Hand Sink Assembly.....	0013 00-1
Troubleshooting Procedures – Kitchen Appliances .....	0014 00-1
Troubleshooting Procedures – MBU .....	0011 00-1
<b>U</b>	
Unit Maintenance Procedures – Cook Center .....	0019 00-1
Unit Maintenance Procedures – Dual Oven Assembly .....	0020-00-1
Unit Maintenance Procedures – Electrical System .....	0026 00-1
Unit Maintenance Procedures – Environmental Control .....	0025 00-1
Unit Maintenance Procedures – Hand Sink Assembly.....	0024 00-1
Unit Maintenance Procedures – Mechanical Room.....	0018 00-1
Unit Maintenance Procedures – Mobile Storage Cabinets .....	0025 00-1
Unit Maintenance Procedures – Mobile Warming Cabinet .....	0021 00-1
Unit Maintenance Procedures – Refrigerators.....	0022 00-1
Unit Maintenance Procedures – Shelter Assembly.....	0017 00-1
Unit Maintenance Procedures – Tray Pack Heater.....	0023 00-1
Unpacking the Mechanical Room.....	0006 00-2
<b>W</b>	
Warranty Information.....	0001 00-2
Water and Drain System Startup.....	0006 00-22
Wiring Diagrams .....	0054 00-1