

**TECHNICAL MANUAL**

**OPERATOR'S, ORGANIZATIONAL, DIRECT SUPPORT AND  
GENERAL SUPPORT MAINTENANCE MANUAL  
INCLUDING REPAIR PARTS AND SPECIAL TOOLS LISTS**

**FOR**

**IMPEDANCE METER: VECTOR ZM-74/U  
(HEWLETT-PACKARD MODEL 4800A WITH MODEL 4801  
PLUG-IN) (NSN 6625-00-167-9861)**

---

**HEADQUARTERS, DEPARTMENT OF THE ARMY**

**2 SEPTEMBER 1981**

**WARNING**

Use this equipment only on power receptacles which are provided with protective grounding. For receptacles which are not provided with the grounding insert, use the three prong adapter recommended in Section II of the manual.

This manual contains copyright material reproduced by permission of the HEWLETT-PACKARD Company.

TECHNICAL MANUAL  
 No. 11-6625-2851-14&P }  
 }  
 }

HEADQUARTERS  
 DEPARTMENT OF THE ARMY  
 WASHINGTON, DC 2 September 1981

**OPERATOR'S, ORGANIZATIONAL, DIRECT SUPPORT AND  
 GENERAL SUPPORT MAINTENANCE MANUAL  
 INCLUDING REPAIR PARTS AND SPECIAL TOOLS LISTS  
 FOR  
 IMPEDANCE METER: VECTOR ZM-74/U  
 (HEWLETT-PACKARD MODEL HP-4800A WITH MODEL 4801 PLUG-IN)  
 (NSN 6625-00-167-9861)**

**REPORTING ERRORS AND RECOMMENDING IMPROVEMENTS**  
 You can help improve this manual. If you find any mistakes or if you know of a way to improve the procedures, please let us know. Mail your letter, DA Form 2028 (Recommended Changes to Publications and Blank Forms), or DA 2028-2 located in back of this manual direct to: Commander, US Army Communications and Electronics Materiel Readiness Command, ATTN: DRSEL- ME-MQ, Fort Monmouth, NJ 07703.  
 In either case, a reply will be furnished direct to you.

**Table of Contents**

SECTION		Paragraph	Page
0	INTRODUCTION		
	Scope .....	0-1	0-1
	Indexes of Publications .....	0-2	0-1
	Maintenance Forms, Records, and Reports.....	0-3	0-1
	Reporting Equipment Improvement Recommendations (EIR).....	0-4	0-1
	Administrative Storage.....	0-5	0-1
	Destruction of Army Electronics Materiel.....	0-6	0-1
	Warranty Information .....	0-7	0-1

**This manual is an authentication of the manufacturer's commercial literature which, through usage, has been found to cover the data required to operate and maintain the equipment. Since the manual was not prepared in accordance with MIL-SPECS and AR 310-3, the format has not been structured to consider levels of maintenance, nor is it structured to the normal style of military publications.**

Section

	<b>Page</b>
<b>I. GENERAL INFORMATION</b>	
1-1 Description .....	1-1
1-6 Accessories Furnished.....	1-1
1-8 Instrument Identification.....	1-1
<b>II. INSTALLATION</b>	
2-1 Initial Inspection.....	2-1
2-5 Preparation For Use.....	2-1
2-6 Power Requirements .....	2-1
2-8 115/230 Volt Operation .....	2-1
2-11 Power Cable .....	2-1
2-14 Cooling .....	2-1
2-16 Bench Operation.....	2-1
2-18 Rack Mounting.....	2-1
2-20 Repackaging For Reshipment.....	2-2
<b>III. OPERATION</b>	
3-1 Introduction.....	3-1
3-5 Operating Controls.....	3-1
3-7 Sliderule Calculator .....	3-1
3-9 Measurement Procedures .....	3-1
3-10 Measuring L and C.....	3-1
3-12 Measurements Involving DC Bias .....	3-4
3-14 Transformer Measurements.....	3-4
3-16 Measurements With AC or Noise Signals Present.....	3-4
3-18 Analog Output Measurements.....	3-4
<b>IV. PRINCIPLES OF OPERATION</b>	
4-1 Introduction.....	4-1
4-4 Overall Description .....	4-1
<b>V. MAINTENANCE</b>	
5-1 Introduction.....	5-1
5-3 Assembly and Component Identification .....	5-1
5-6 Test Equipment Required .....	5-1
5-8 Performance Checks .....	5-1
5-11 Adjustment Procedures.....	5-9
5-26 Troubleshooting Procedures .....	5-11
<b>VI. REPLACEABLE PARTS</b>	
6-1 Introduction.....	6-1
6-4 Ordering Information.....	6-1
6-6 Manual Backdating Information.....	6-1
<b>VII. CIRCUIT DIAGRAMS</b>	
7-1 Introduction.....	7-1
7-3 Assembly and Component Identification .....	7-1
7-5 Waveforms and Voltage Measurements .....	7-1
7-7 Talking Schematics .....	7-1
<b>VIII. PART NUMBER-NATIONAL STOCK NUMBER CROSS REFERENCE</b>	
INDEX.....	8-1
APPENDIX A. REFERENCES .....	A-1
B. MAINTENANCE ALLOCATION	
Section I. Introduction .....	B-1
II. Maintenance Allocation Chart.....	B-3
III. Tool and Test Equipment Requirements.....	B-5

## LIST OF TABLES

Table		Page
1-1	Specifications.....	1-0
3-1	Scale Factor for Direct LC Measurements.....	3-4
5-1	Schematics and Circuit Board Illustrations.....	5-1
5-2	Recommended Test Equipment and Accessories.....	5-2
5-3	Performance Checks.....	5-3
5-4	Out-of-Circuit Transistor Resistance Measurements.....	5-12
5-5	Typical Ohmmeter Ranges and Currents.....	5-13
6-1	Reference Designation Index.....	6-2
6-2	Reference Designation Index 4801A Plug-in.....	6-14
6-3	Replaceable Parts Index.....	6-16
7-1	Schematic Notes and Symbols.....	7-0

## LIST OF ILLUSTRATIONS

Figure		Page
1-1	Model 4800A Vector Impedance Meter.....	1-1
1-2	00610A Terminal Shield.....	1-2
1-3	13525A Calibration Resistor.....	1-2
2-1	Rack Mounting Installation Diagram.....	2-2
3-1	4800A Front Panel Operating Controls.....	3-2
3-2	4800A Rear Panel Operating Controls.....	3-3
4-1	4800A Block Diagram.....	4-0
5-1	4800A Top View.....	5-0
5-2	Performance Check Test Card.....	5-7/5-8
5-3	Power Supply Test Points.....	5-9
5-4	Dial Cord Replacement.....	5-14/5-15
5-5	Troubleshooting Tree Number 1.....	5-16
5-6	Troubleshooting Tree Number 2.....	5-18
5-7	Troubleshooting Tree Number 3.....	5-20
5-8	Troubleshooting Tree Number 4.....	5-22
6-1	4800A Vector Impedance Meter.....	6-19
6-2	A14 Schematic and Component Locator for Serials Prefixed 805 and Below.....	6-21
6-3	A17 Schematic and Component Locator for Serials Prefixed 805 and Below.....	6-22
7-1	Functional Block Diagram.....	7-3
7-2	Oscillator AGC Amplifier.....	7-5
7-3	Z Range Switching and 4801A Direct Measurement Plug-in.....	7-7
7-4	Voltage Channel Amplifiers.....	7-9
7-5	Current Channel Amplifiers.....	7-11
7-6	Detector and DC Amplifier.....	7-13
7-7	Phase Measurement Circuits.....	7-15
7-8	Power Supplies.....	7-17
7-9	Analog Outputs.....	7-19

**Section 0. INTRODUCTION****0-1. Scope**

This manual contains the general description, installation, operation, principles of operation, and maintenance of the test instrument, which is known as the Impedance Meter: Vector ZM-74/U.

**0-2. Indexes of Publications**

Refer to the latest issue of DA PAM 3104 to determine whether there are new editions, changes, additional publications or modification work orders pertaining to the equipment.

**0-3. Maintenance Forms, Records and Reports**

a. *Reports of Maintenance and Unsatisfactory Equipment.* Department of the Army forms and procedures used for equipment maintenance will be those prescribed by TM 38-750, The Army Maintenance Management System.

b. *Report of Item and Packaging Discrepancies.* Fill out and forward SF 364 (Report of Discrepancy (ROD)) as prescribed in AR 735-11-2/DLAR 4140.55/NAV-MATINST 4355.73/AFR 400.54/MCO 4430.E.

c. *Discrepancy in Shipment Report (DISREP) (SF 361).* Fill out and forward Discrepancy in Shipment Report (DISREP) (SF 361) as prescribed in AR 55-38/NAVSUPINST 4610.33B/AFR 75-18/MCO P4610.19C and DLAR 4500.15.

**0-4. Reporting Equipment Improvement Recommendations (EIR)**

If your impedance Meter: Vector ZM-74t needs improvement, let us know. Send us an EIR. You, the user, are the only one who can tell us what you don't like about your equipment. Let us know why you don't like the design. Tell us why a procedure is hard to perform. Put it on an SF 368 (Quality Deficiency Report). Mail it to Commander, US Army Communications and Electronics Materiel Readiness Command, ATTN: DRSEL-ME-MQ, Fort Monmouth, NJ 07703. We'll send you a reply.

**0-6. Destruction of Army Electronics Materiel**

Destruction of Army electronics materiel to prevent enemy use shall be in accordance with TM 750-244-2.

**0-5. Administrative Storage**

For administrative storage of your Impedance Meter: Vector ZM-74/U Wrap set in heavy kraft paper and tape securely with packaging tape.

**0-7. Warranty Information**

The Impedance Meter: Vector ZM-74/U (HEWLETT-PACKARD MODEL, 4800A) by HEWLETT-PACKARD for one year from the date of shipment. Warranty period starts on the date found in block 23 of DA Form 2408-9 in the logbook. Report all defects in material or workmanship to your supervisor, who will take appropriate action through your organizational maintenance shop.

TABLE 1-1. SPECIFICATIONS

**FREQUENCY CHARACTERISTICS.**

**RANGE:** 5 Hz to 500 kHz in five bands; 5 to 50 Hz, 50 to 500 Hz, 0.5 to 5 kHz, 5 to 50 kHz, and 50 to 500 kHz.

**ACCURACY:** ±4% from 5 Hz to 50 Hz, ±2% from 50 Hz to 500 kHz, ±1% at 15.92 on FREQUENCY dial from 159.2 Hz to 159.2 kHz, ±2% at 15.92 Hz.

**MONITOR OUTPUT:** level; 0.2 V rms minimum; source impedance: 600 ohms in series with 50 μF.

**IMPEDANCE MEASUREMENT CHARACTERISTICS.**

**RANGE:** 1 ohm to 10 megohms in seven ranges: 10 ohms, 100 ohms, 1 K ohms, 10 K ohms, 100K ohms, 1 megohm and 10 megohms full scale.

**ACCURACY:** ±5% of reading.

**PHASE ANGLE MEASUREMENT CHARACTERISTICS.**

**RANGE:** 0° to ±90°

**ACCURACY:** ±6°

**CALIBRATION:** increments of 5°

**DIRECT INDUCTANCE MEASUREMENT CAPABILITIES.**

**RANGE:** 1 μH to 100,000 H, direct reading at decades multiples of 15.92 Hz.

**ACCURACY:** ±7% of reading for Q greater than 10 from 159.2 Hz to 159.2 kHz; ±8% of reading for Q greater than 10 at 15.92 Hz.

**DIRECT CAPACITANCE MEASUREMENT CAPABILITIES.**

**RANGE:** 0.1 pF to 10,000 μF, direct reading at decade multiples of 15.92 Hz.

**ACCURACY:** ±7% of reading for D less than 0.1 from 159.2 Hz to 159.2 kHz, ±8% of reading for D less than 0.1 at 15.92 Hz.

**MEASURING TERMINAL SIGNAL CHARACTERISTICS.**

**WAVESHAP:** Sinusoidal.

**SIGNAL LEVEL:** 2.7 mV rms 1 ohm to 1 K ohm, approx. 2.7 mV rms 1000 ohms to 10,000 ohms, approx. 27 mV rms 10,000 ohms to 100,000 ohms, approx. 270 mV rms 100,000 ohms to 1 megohm, approx. 2.7 V rms 1 megohm to 10 megohms.

**EXTERNAL OSCILLATOR REQUIREMENTS.**

**LEVEL:** 0.8 V rms ±5%

**RECORDER OUTPUTS.**

**FREQUENCY:** level; 0 to 1 volt nominal; source impedance, 0 to 1000 ohms nominal, proportional to FREQUENCY dial rotation.

**IMPEDANCE:** level; 0 to 1 volt nominal; source impedance, 1000 ohms nominal.

**PHASE ANGLE:** level; 0 to ±0.9 volts nominal; source impedance, 1000 ohms nominal.

**GENERAL.**

**ACCESSORIES FURNISHED:** 13525A Calibration Resistor, 00610A Terminal Shield, circuit board extender, rack mounting kit.

**DIMENSIONS:**

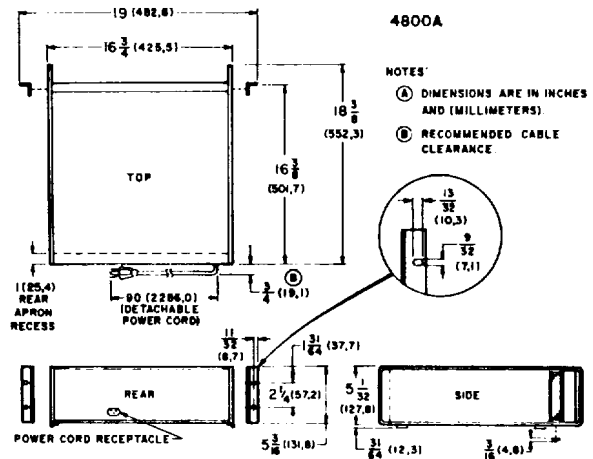

**NOTES:**  
 ① DIMENSIONS ARE IN INCHES AND (MILLIMETERS)  
 ② RECOMMENDED CABLE CLEARANCE

**WEIGHT:** net 25 lbs (11.3kg), shipping 36 lbs (16.2kg).

**POWER:** 105 to 125 volts or 210 to 250 volts, 50 to 400 Hz, 27 w.

## SECTION I GENERAL INFORMATION

### 1-1. DESCRIPTION

1-2. The Model 4800A Vector Impedance Meter (Figure 1-1) is a self-contained instrument designed to measure complex impedances for a wide variety of applications. Impedance magnitude is measured from 1 ohm to 10 megohms in seven ranges and phase angle from -90 degrees to +90 degrees. The measurement frequency is adjustable from 5 Hz to 500 kHz in five ranges. Complete specifications are given in Table 1-1.

1-3. Impedance of components, complex networks, and other two-terminal devices is measured by connecting the "unknown" to the terminals of the 4801A Direct Measurement Plug-in furnished with the Vector Impedance Meter. After selecting the desired test frequency and adjusting the impedance range switch, both the impedance magnitude in ohms and phase angle in degrees are read directly on front panel meters.

1-4. The 4800A injects a signal from an internal oscillator into the "unknown" and monitors the voltage and current. In the first three impedance ranges the current is maintained at a constant level and the voltage is measured, providing a signal proportional to the impedance magnitude. In the upper four impedance ranges the voltage is maintained at a constant level and the current is measured, providing a signal inversely proportional to the impedance magnitude. A phase

detector measures the phase difference between the current and voltage.

1-5. The 4800A is equipped with analog outputs for the impedance magnitude, phase angle, and frequency parameters. These outputs may be used to obtain permanent traces on a two-pen X-Y recorder. The analog outputs can also be connected to a digital voltmeter for a high resolution digital readout with excellent repeatability.

### 1-6. ACCESSORIES FURNISHED

1-7. An -hp- 00610A Terminal Shield (Figure 1-2) is supplied with the 4800A to reduce terminal capacitance by a factor of one hundred below unshielded terminal capacitance. An -hp- 13525A Calibration Resistor (Figure 1-3) is supplied to provide a convenient check of impedance measurement accuracy. In addition, an -hp- 5060-0775 Rack Mounting Kit and -hp- 5060-2693I Circuit Board Extender are also supplied.

### 1-8. INSTRUMENT IDENTIFICATION

1-9. Each Model 4800A carries a two-section, eight-digit serial number (000-00000) which is stamped on a plate fastened to the rear panel. The five-digit number is an identification unique to each

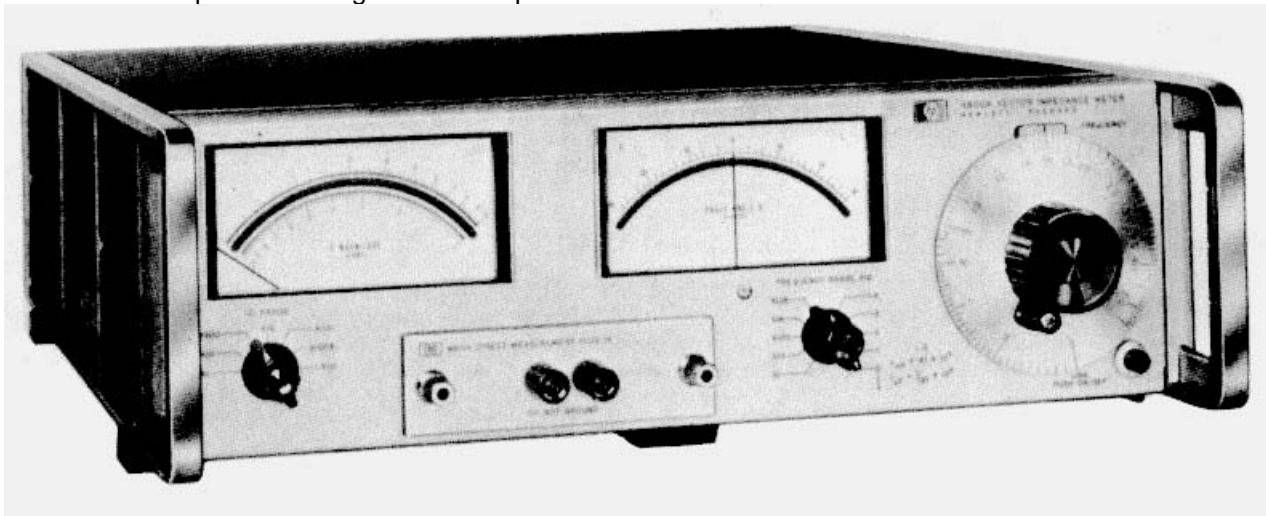

Figure 1-1. Model 4800A Vector Impedance Meter



instrument, and the three-digit number is a serial prefix used to document instrument revisions.



Figure 1-2. 00610A Terminal Shield



Figure 1-3. 13525A Calibration Resistor

## SECTION II. INSTALLATION

### 2-1. INITIAL INSPECTION

**2-2. MECHANICAL CHECK.** If damage to the shipping carton is evident, ask that the carrier's agent be present when the instrument is unpacked. Inspect the instrument for scratches, -dents, broken knobs and switches, and any other mechanical damage. Also check the cushioning material for signs of severe stress as an indication of rough handling in transit.

**2-3. PERFORMANCE CHECK.** The electrical performance of the 4800A should be verified as soon as possible after receipt. A performance check that is suitable for initial inspection is contained in Section V.

**2-4. CLAIM FOR DAMAGE.** If, upon receipt, the 4800A is damaged or fails to meet performance specifications, refer to paragraph 0-3 in Section 0 of this manual.

Retain the shipping carton and padding material for the carrier's inspection.

### 2-5. PREPARATION FOR USE

#### 2-6. POWER REQUIREMENTS

2-7. The 4800A requires a power source of 105 to 125 V or 210 to 250 V, 50 to 400 Hz, which can supply approximately 27 watts.

#### 2-8. 115/230 VOLT OPERATION

2-9. A two-position slide switch, located on the rear panel, permits operation from either a 115 or 230 volt power source. Before connecting the 4800A to the power source, check that the number visible on the slide switch matches the nominal line voltage of the source. If required, slide the switch to the other position using a thin-bladed screwdriver.

2-10. When the instrument leaves the factory, the proper fuse is installed for 115-volt operation. An envelope containing a fuse for 230-volt operation is attached to the front handle. Markings on the rear panel adjacent to the fuse holder indicate the correct fuse rating for operation from either power source. Make sure that the correct fuse is installed if the position of the slide switch is changed.

### 2-11. POWER CABLE

2-12. To protect operating personnel, the National Electrical Manufacturers' Association (NEMA) recommends that instrument panels and cabinets be grounded. The 4800A is equipped with a detachable, three-conductor power cable which, when plugged into an appropriate receptacle, grounds the panel and cabinet of the instrument. The offset pin on the power cable three-prong connector is the ground pin.

2-13. To preserve the protective feature when operating the instrument from a two-contact outlet, use a three-prong adapter (-hp- Stock No. 1251-0048) and connect the green pigtail on the adapter to ground.

### 2-14. COOLING

2-15. During operation of the 4800A, the temperature of the surrounding air should not exceed 55°C (131°F). Clearance at the rear and sides of the cabinet should be provided to maintain adequate cooling. The clearances provided by the plastic feet in bench stacking and the filler strips used in rack mounting are adequate for the top and bottom cabinet surfaces.

### 2-16. BENCH OPERATION

2-17. The 4800A has plastic feet which provide clearance for air circulation beneath the instrument during bench operation. The feet are also designed to make all full width -hp- modular cabinet instruments, such as the 4800A, self-aligning when stacked. In addition, a fold-away tilt stand is provided which permits inclining the instrument for ease in adjusting controls.

### 2-18. RACK MOUNTING

2-19. The 4800A can be modified for rack mounting by removing the plastic feet and tilt stand from the bottom, and by adding a filler strip and two rack mounting flanges to the front panel. These parts and the attaching hardware are contained in the rack mounting kit (-hp- Stock No. 5060-0775) which is furnished with the instrument. The kit and installation instruments are shown in Figure 2-1.

**2-20. REPACKAGING FOR RESHIPMENT**

2-21. The original shipping carton and packing material should be used for repackaging.

The packaging materials should include the following:

- a double-walled carton

- heavy paper or cardboard to protect all instrument surfaces
- extra material around projecting parts of instrument
- at least four inches of tightly-packed shock-absorbing material surrounding the instrument.
- durable shipping tape to securely seal the carton

**INSTRUCTIONS**

1. REMOVE TILT STAND, FEET, AND TRIM STRIP.
2. ATTACH FILLER STRIP AND FLANGES WITH LARGE NOTCH ON FLANGE TO INSTRUMENT BOTTOM.

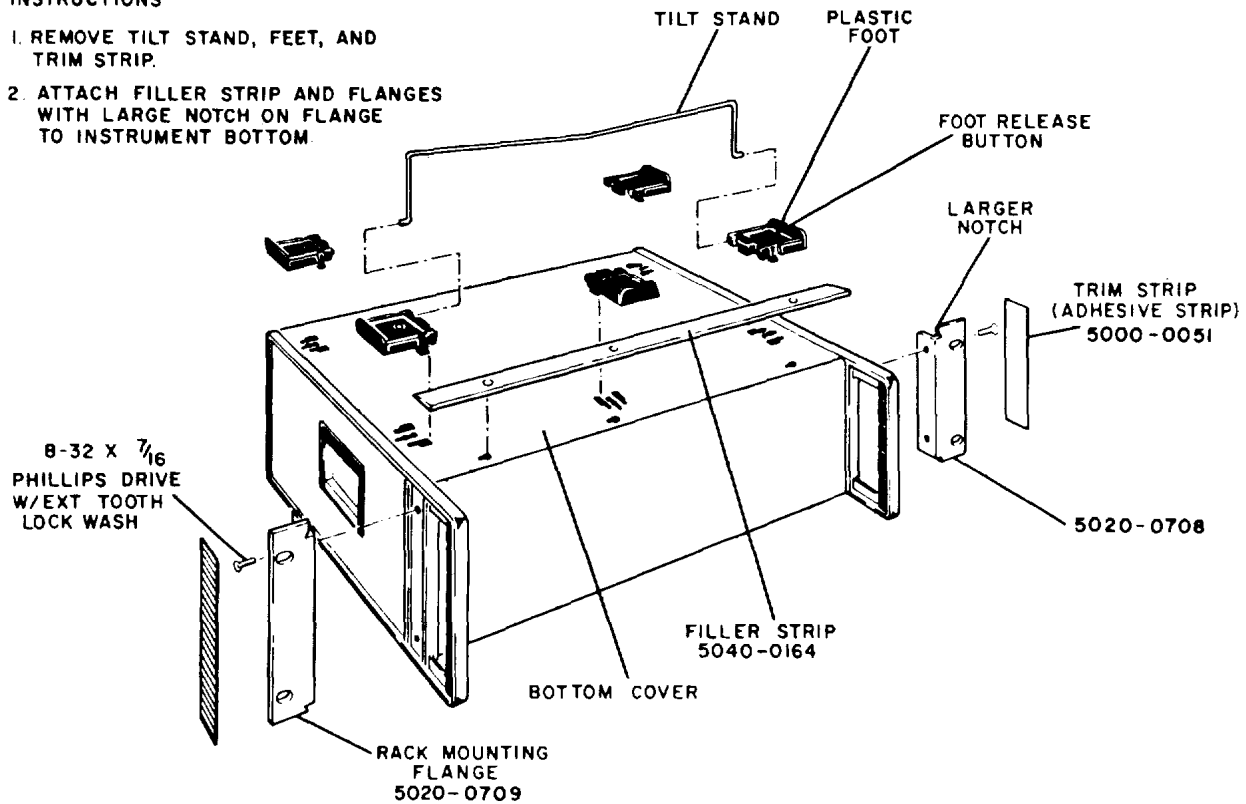

Figure 2-1. Rack Mounting Installation Diagram

## SECTION III. OPERATION

### 3-1. INTRODUCTION

3-2. The 4800A Vector Impedance Meter measures impedance directly by injecting a signal into the "unknown" and comparing the ratio of voltage to current. Depending on the impedance range, either the voltage or current is held constant by an automatic leveling control circuit (ALC). Impedance is directly proportional to voltage with the current held constant, and inversely proportional to current with the voltage held constant. Phase angle is measured by comparing the phase relationship between the voltage and current waveforms. Impedance magnitude is measured from 1 ohm to 10 megohms in seven decade ranges; phase angle is indicated from -90 degrees to +90 degrees.

3-3. The Z MAGNITUDE meter has two scales: a direct-reading black scale used with the black engraved Z RANGE positions X1, X10, and X100, and an inverse-reading red scale used with the red engraved Z RANGE positions X1K, X10K, X100K, and X1M. An off-scale reading to the right, with the Z RANGE switch at a black engraved position, indicates the range is too low and the switch should be advanced clockwise. An off-scale reading to the right, with the Z RANGE switch at a red engraved position, indicates the range is too high and the switch should be turned counterclockwise.

#### NOTE

After changing ranges, allow a few seconds for circuits to return from an overload condition; if pointer does not indicate on scale, change to the next range.

3-4. The analog outputs on the rear panel provide dc voltages proportional to Z MAGNITUDE meter deflection, PHASE ANGLE meter deflection, and FREQUENCY dial rotation.

### 3-5. OPERATING CONTROLS

3-6. Figures 3-1 and 3-2 identify and briefly describes the purpose of each panel control, switch, and connector.

### 3-7. SLIDERULE CALCULATOR

3-8. A slide rule calculator ( 5952-251 b) has been shipped with the equipment to simplify the more common conversions and calculations that arise with impedance measurements. One side of the slide rule is a Vector Impedance Calculator that resolves the impedance vector Z into its resistive and reactive components. The other side of the slide rule is a Capacitance-Inductance Reactance Calculator that is especially useful for solving resonant frequency problems. The calculator may also be used as a scale factor "nomograph" when direct-reading component measurements are being made with the 4800A (see Paragraph 3-10). The simple instructions necessary to use the calculators are printed on the slide rule (P/N5952-2516),

### 3-9. MEASUREMENT PROCEDURES

#### 3-10. MEASURING L AND C

3-11. The 4800A provides readings in capacitance and inductance when the FREQUENCY dial is set to the "LC" mark (15.92). Thus, at the frequencies 15.92 Hz, 159.2 Hz, 1.592 kHz, and 159.2 kHz, readings on the Z MAGNITUDE meter scales can be converted to microfarads or microhenries using the "LC" formulas engraved on the front panel, and components may be measured directly. Table 3-1 gives the scale factors that apply when the 4800A is operated in this mode.

Example 1: A coil indicating 800 ohms on the Z MAGNITUDE meter with the FREQUENCY RANGE switch set to X10 (n = 3), has a value of:

$$L_p H = Z \times 10_n$$

$$L/H = 800 \times 10^3$$

$$L = 0.8 H$$

Example 2: A capacitor indicating 30 K ohms on the Z MAGNITUDE meter with the FREQUENCY RANGE switch set to X1K (n = 1), has a value of:

$$CUF = 1/Z \times 10_n$$

$$CUF = 1/30K \times 10^1$$

$$C = 333 pF$$

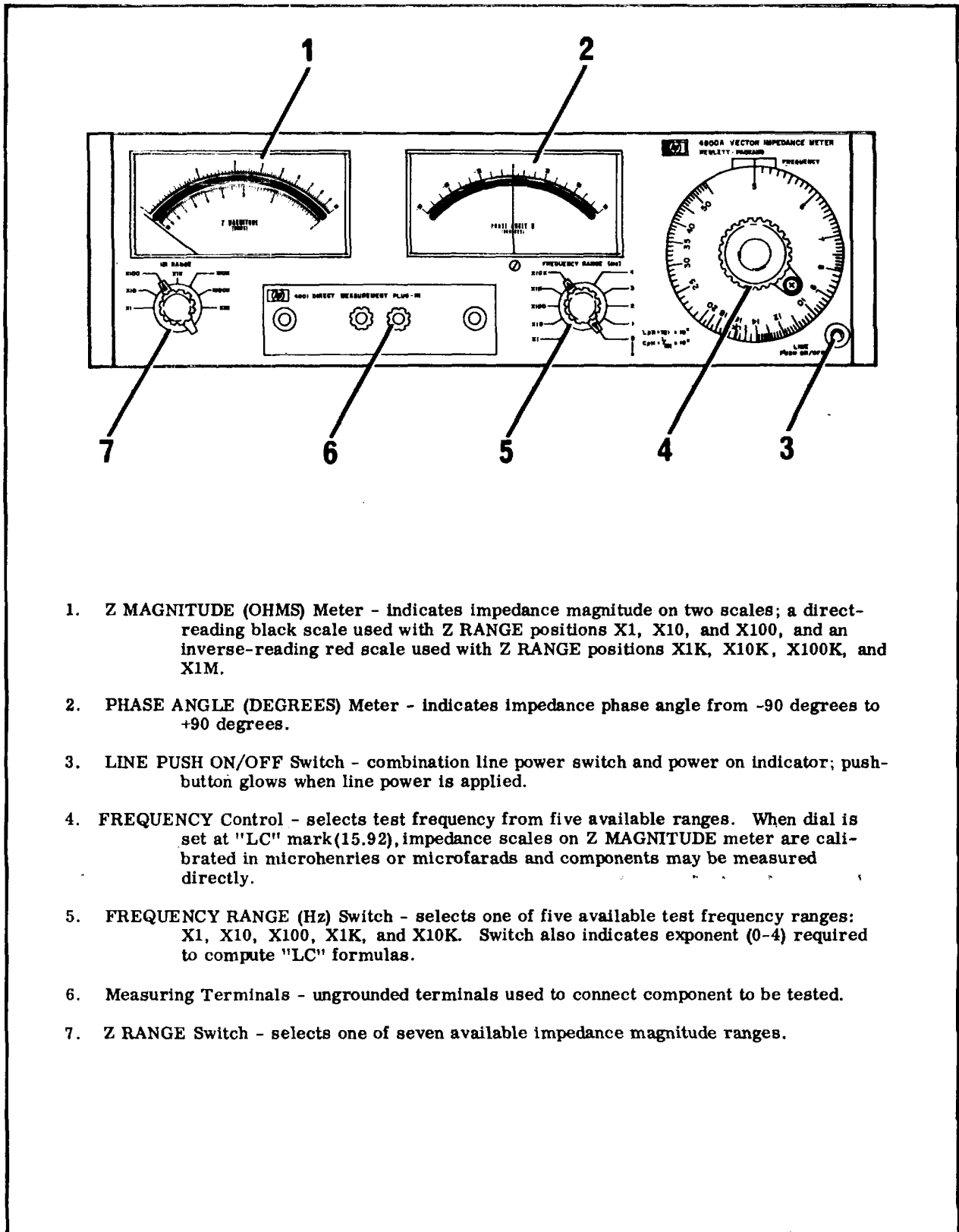

1. Z MAGNITUDE (OHMS) Meter - indicates impedance magnitude on two scales; a direct-reading black scale used with Z RANGE positions X1, X10, and X100, and an inverse-reading red scale used with Z RANGE positions X1K, X10K, X100K, and X1M.
2. PHASE ANGLE (DEGREES) Meter - indicates impedance phase angle from -90 degrees to +90 degrees.
3. LINE PUSH ON/OFF Switch - combination line power switch and power on indicator; push-button glows when line power is applied.
4. FREQUENCY Control - selects test frequency from five available ranges. When dial is set at "LC" mark(15.92), impedance scales on Z MAGNITUDE meter are calibrated in microhenries or microfarads and components may be measured directly.
5. FREQUENCY RANGE (Hz) Switch - selects one of five available test frequency ranges: X1, X10, X100, X1K, and X10K. Switch also indicates exponent (0-4) required to compute "LC" formulas.
6. Measuring Terminals - ungrounded terminals used to connect component to be tested.
7. Z RANGE Switch - selects one of seven available impedance magnitude ranges.

Figure 3-1. 4800A Front Panel Operating Controls

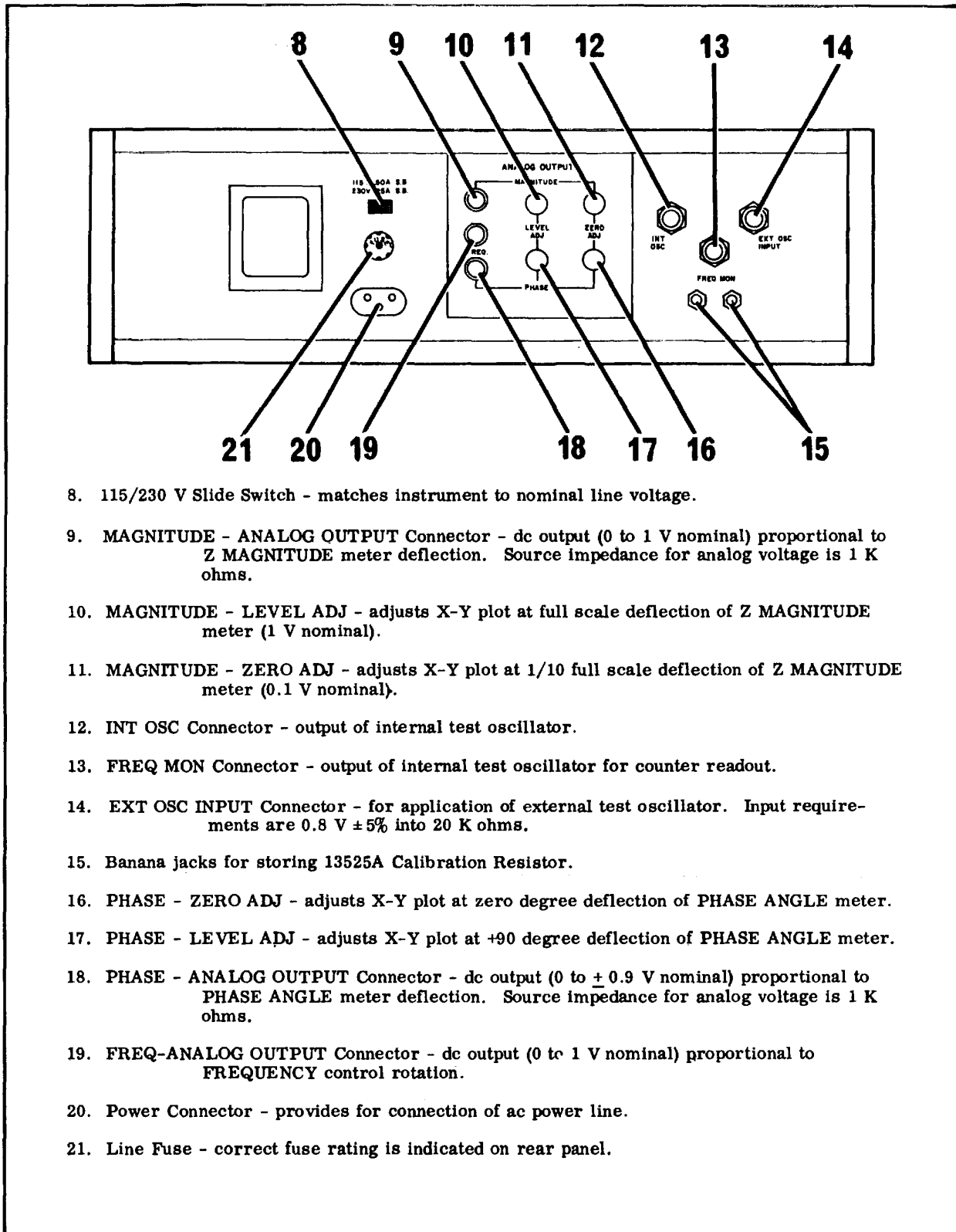

- 8. 115/230 V Slide Switch - matches instrument to nominal line voltage.
- 9. MAGNITUDE - ANALOG OUTPUT Connector - dc output (0 to 1 V nominal) proportional to Z MAGNITUDE meter deflection. Source impedance for analog voltage is 1 K ohms.
- 10. MAGNITUDE - LEVEL ADJ - adjusts X-Y plot at full scale deflection of Z MAGNITUDE meter (1 V nominal).
- 11. MAGNITUDE - ZERO ADJ - adjusts X-Y plot at 1/10 full scale deflection of Z MAGNITUDE meter (0.1 V nominal).
- 12. INT OSC Connector - output of internal test oscillator.
- 13. FREQ MON Connector - output of internal test oscillator for counter readout.
- 14. EXT OSC INPUT Connector - for application of external test oscillator. Input requirements are 0.8 V  $\pm$  5% into 20 K ohms.
- 15. Banana jacks for storing 13525A Calibration Resistor.
- 16. PHASE - ZERO ADJ - adjusts X-Y plot at zero degree deflection of PHASE ANGLE meter.
- 17. PHASE - LEVEL ADJ - adjusts X-Y plot at +90 degree deflection of PHASE ANGLE meter.
- 18. PHASE - ANALOG OUTPUT Connector - dc output (0 to + 0.9 V nominal) proportional to PHASE ANGLE meter deflection. Source impedance for analog voltage is 1 K ohms.
- 19. FREQ-ANALOG OUTPUT Connector - dc output (0 to 1 V nominal) proportional to FREQUENCY control rotation.
- 20. Power Connector - provides for connection of ac power line.
- 21. Line Fuse - correct fuse rating is indicated on rear panel.

Figure 3-2. 3800A Rear Panel Controls

Table 3-1. Scale Factors for Direct L1C Measurements

(Frequency Range)	Direct Reading	Direct Reading
	C Range (n=0) (n=4)	L Range (n=0) (n=4)
Z Range		
X1	0.1AF to 10000pF	1pH to 100mH
X10	0.01IF to 1000pF	10H to 1H
X100	0.001.F to 100pF	100IpH to 10H
X1K	100pF to 10pF	1mH to 100H
X10K	10pF to 1pF	10mH to 1000H
X100K	1pF to 0.1pF	100mH to 10000H
X1M	0.1pF to 0.01pF	1H to 100000H

**3-12. Measurements Involving DC Bias**

3-13. If it is necessary to make impedance measurements in the presence of dc bias, a blocking capacitor must be used to isolate the de from the 4800A. The impedance of the capacitor must be small compared to that of the device under test. This can be verified with the 4800A. Since the de bias supply appears in parallel, with the unknown, the impedance of this portion of the circuit must be high with relation to the unknown. If this condition cannot be achieved, the bias supply impedance will reduce the impedance of the unknown. This reading can be corrected, however, by making a separate measurement of the bias supply impedance and then correcting the data. The bias supply must be ungrounded unless the regulating resistor is very large. A large resistor with a grounded supply will isolate the 4W00A test signal from ground.

**3-14. Transformer Measurements**

3-15. The 4800A has the capability to quickly characterize transformers by providing a plot of vector impedance as a function of frequency. Measurements that can be made include the primary inductance, primary resistance, secondary inductance, secondary resistance, and turns ratio.

**3-16. Measurements with AC or noise signals present**

3-17. Measurements with external ac or noise signals present require the use of careful techniques. The cording. The analog outputs may also be connected to an -hp- Model 3440A Digital Voltmeter, providing a digital readout for greater resolution. In addition, an ideal go-no-go impedance checkout system can be obtained by combining the 4800A with the -hp- Model 3434A Comparator.

**3-20. Frequency Analog Output.**

To calibrate the X-axis of an X-Y recorder to a given dial frequency, proceed as follows:

**NOTE**

The FREQ ANALOG OUTPUT has no

exact mathematical relationship to the frequency dial but it is approximately logarithmic.

impedance measuring circuits of the 4800A may amplify an unwanted signal to the same order of magnitude as the internal test signal. This situation will result in a completely spurious impedance reading. The condition is generally easy to recognize, however, since it will become difficult to obtain a stable on-scale reading of either impedance or phase, or both. To help eliminate interference from unwanted signals, bandpass filtering is used for each frequency range. Interference can sometimes be effectively filtered by choosing a frequency two decades away from the unwanted signal. In measurements where interfering noise is likely, such as with antennas, electrical isolation is often necessary. In addition, devices which have the property of converting some other parameter to electrical energy must be isolated from excitation. For instance, a piezoelectric transducer will have to be isolated from mechanical vibration to prevent the generation of unwanted signals. In addition to the precautions mentioned, care should be taken not to apply more than 1 volt rms of external ac to the 4801A measurement terminals; otherwise damage may result to protective diodes CR1-4 in the 4801A.

**3-18. Analog Output Measurements**

3-19. The 4800A analog outputs may be used to drive the -hp- Model 136A Two-Pen X-Y Recorder. This will provide a continuous record of impedance and phase as a function of various parameters, such as frequency or bias current. Paragraphs 3-20 through 3-22 describe the analog output adjustment procedures for X-Y re-

a. Connect FREQ output to the recorder X-axis input.

b. With recorder pens raised, rotate 4800A FREQUENCY dial from "5" to "50" and mark desired frequency points on the recorder paper.

**NOTE**

Once this frequency calibration has been accomplished, it need not be repeated for subsequent plots. The original calibration may be transferred from one plot to the next.

**3-21. Magnitude Analog Output.** This procedure adjusts the MAGNITUDE ZERO ADJ and LEVEL ADJ for proper X-Y recorder operation. Proceed as follows:

a. Set 4800A controls as follows:

Z RANGE X10  
 FREQUENCY RANGE X1K  
 FREQUENCY dial "LC" (15.92)

b. Connect dc voltmeter to MAGNITUDE output and a 0.1 uF capacitor to measurement terminals.

- c. Adjust FREQUENCY dial for a reading of 10.0 on the Z MAGNITUDE meter black scale.
- d. Adjust MAGNITUDE LEVEL ADJ for 1.0 V on voltmeter.
- e. Change Z RANGE to X100.
- f. Adjust FREQUENCY dial for a reading of 1.0 on the Z MAGNITUDE meter black scale.
- g. Adjust MAGNITUDE ZERO ADJ for 0.1 V on voltmeter; due to interaction between controls, this procedure must be repeated until desired accuracy is achieved.

**NOTE**

The MAGNITUDE output voltage is directly proportional to readings on the black meter scale ranges and inversely proportional to readings on the red meter scale ranges.

**3-22. PHASE ANALOG OUTPUT.** This procedure adjusts the PHASE LEVEL ADJ and ZERO ADJ for proper X-Y recorder operation. Proceed as follows:

- a. Set 4800A controls as follows:

Z RANGE X1K  
 FREQUENCY RANGE X100  
 FREQUENCY dial "LC" (15.92)

- b. Connect dc voltmeter to PHASE output and 1 KQ Calibration resistor to measurement terminals.
- c. Adjust PHASE ZERO ADJ for 0 V on voltmeter.
- d. Connect a 0.1 IF capacitor to measurement terminals.
- e. Adjust PHASE LEVEL ADJ for -0.9 V on voltmeter; due to interaction between controls, this procedure must be repeated until desired accuracy is achieved.



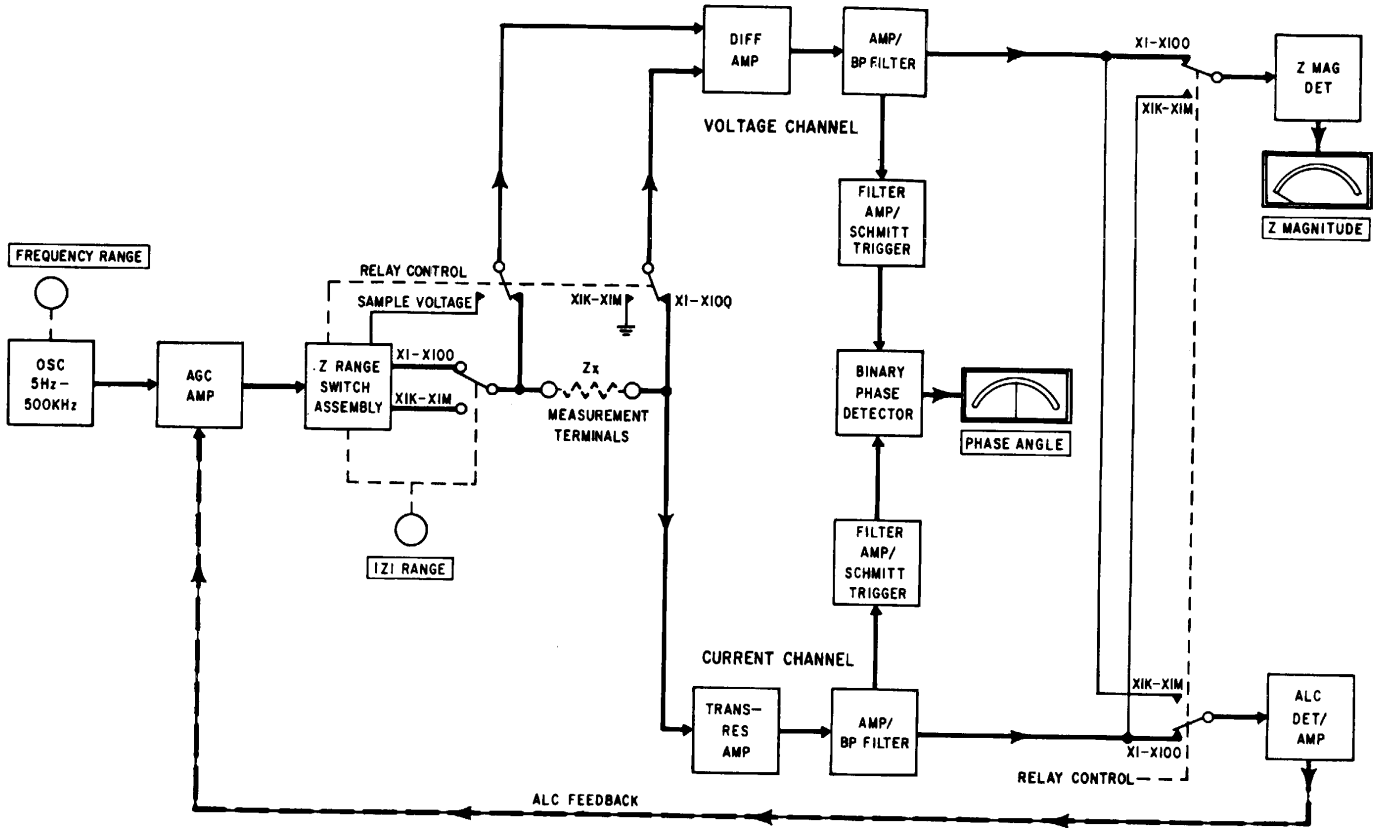

Figure 4-1. 4800A Block Diagram

#### 4-1. INTRODUCTION

4-2. The 4800A Vector Impedance Meter measures impedance magnitude and phase angle of passive components and networks over an adjustable frequency range of 5 Hz to 500 kHz. Impedances up to 1 K ohms are measured by passing a predetermined constant current through the "unknown" and measuring the voltage across it; this voltage is proportional to impedance magnitude. Impedances between 1 K ohms and 10 megohms are measured by applying a predetermined constant voltage across the "unknown" and measuring the current through it; this current is inversely proportional to impedance magnitude. Phase angle measurements are obtained by comparing the relative phase between the voltage and current by means of a phase detector.

4-3. The following paragraphs describe, at a block diagram level, the overall relationship between the major functional groups of the 4800A. Detailed descriptions of the individual circuits are provided in Section VII by means of text overlays adjacent to corresponding schematics.

#### 4-4. OVERALL DESCRIPTION

4-5. A simplified block diagram (Figure 4-1) illustrates 4800A operation in the first three decade ranges of the Z RANGE switch. In these ranges a constant current is applied to the "unknown" at the measurement terminals, and the voltage across the "unknown" is measured.

4-6. An oscillator provides a test signal within the frequency range of 5 Hz to 500 kHz, as determined by the FREQUENCY RANGE switch and FREQUENCY dial, to an AGC amplifier. The AGC amplifier holds the signal current through the Z RANGE switch and the "unknown" at a constant level by means of an ALC feedback loop. This current is applied to a transresistance amplifier which provides an output voltage proportional to the current flowing in the "unknown". The voltage is amplified, filtered, and

forwarded through relay contacts to an ALC amplifier/detector. A detected leveling signal then fed back to the AGC amplifier.

4-7. In the first three impedance ranges the voltage across the "unknown" is applied to a differential amplifier through two sets of relay contacts. The output of the differential amplifier is amplified, filtered, and forwarded through relay contacts to a Z magnitude detector. Output from the detector is proportional to the impedance of the "unknown" which is indicated on the Z MAGNITUDE meter.

4-8. When the 4800A is operated in the upper four ranges of the Z RANGE switch, the relay contacts switch to their alternate positions, and the voltage is held constant while the current through the "unknown" is measured. This current is applied to the Z magnitude detector through relay contacts. Output from the detector is inversely proportional to the impedance of the "unknown" which is indicated on the Z MAGNITUDE meter.

4-9. The voltage is maintained at a constant level during 4800A operation in the higher impedance ranges by a sample voltage that is applied to the differential amplifier. The output of the amplifier is forwarded through relay contacts to the ALC detector/amplifier. A detected leveling signal is then fed back to the AGC amplifier.

4-10. Phase angle is measured the same way in both the constant current and constant voltage modes of operation. Signals from the current and voltage channels are filtered to improve signal-to-noise ratio and then converted to pulses in Schmitt trigger circuits (zero-crossing detectors). The output pulses from the Schmitt triggers drive a binary phase detector, which provides an output voltage proportional to the phase difference between the two channels. A zero-center PHASE ANGLE meter reads this voltage as phase angle in degrees.

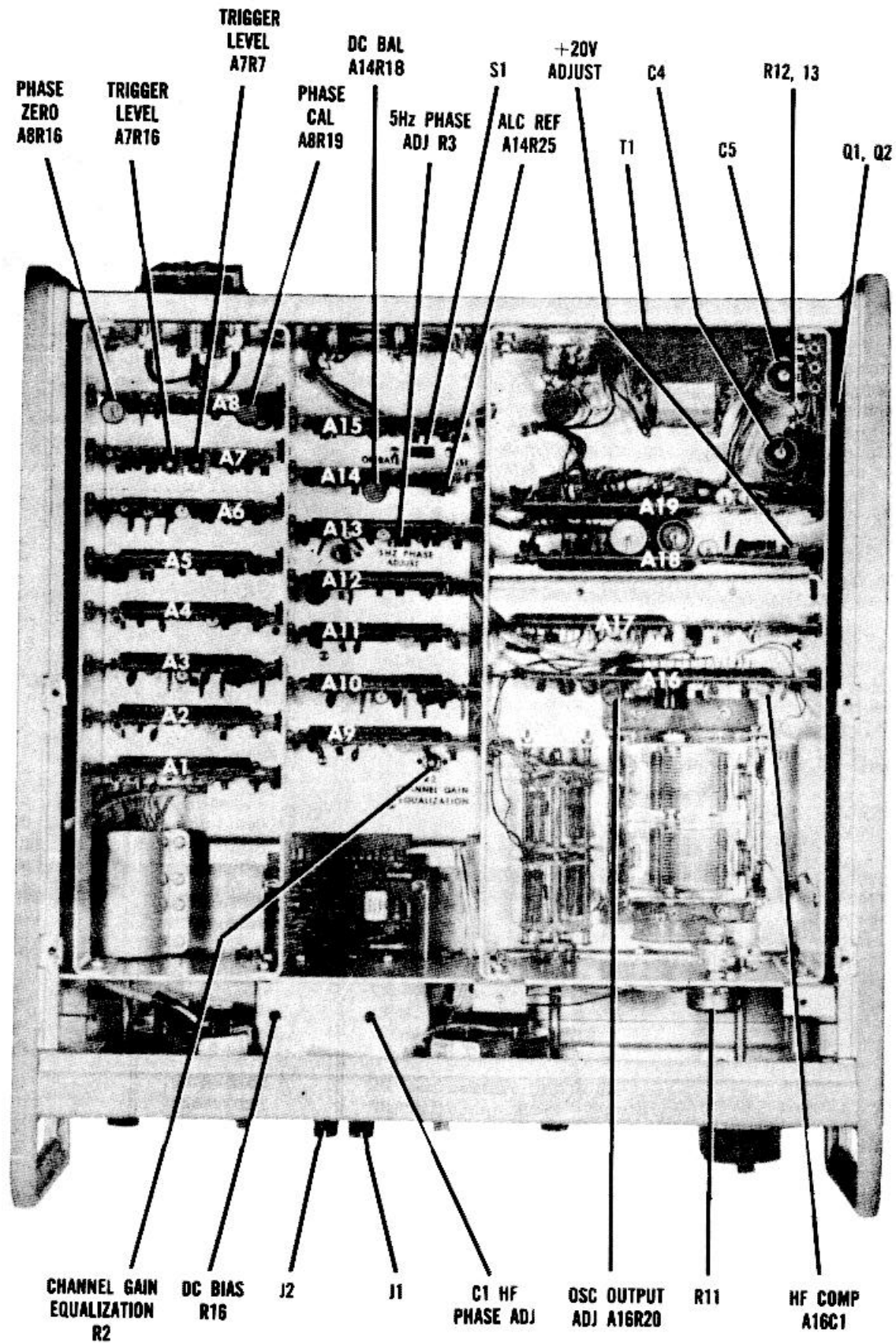

Figure 5-1. 4800A Top View

**SECTION V  
MAINTENANCE**

**5-1. INTRODUCTION**

5-2. This section contains information required to maintain the 4800A Vector Impedance Meter. The information covered is summarized below.

- a. Assembly and Component Identification - Identifies and physically locates the 4800A assemblies, components and calibration adjustments.
- b. Test Equipment Required - Lists and describes test equipment necessary to perform the operations in this section.
- c. Performance Checks - Verify proper operation of the 4800A.
- d. Adjustment Procedures - Used for adjustment of 4800A when repaired.
- e. Troubleshooting Procedures - Used as an aid to locating 4800A malfunctions.

**5-3. ASSEMBLY AND COMPONENT IDENTIFICATION**

5-4. Figure 5-1 identifies 4800A circuit board assemblies and calibration adjustments. Table 5-1 lists the assemblies numerically by reference designation and indexes each to its schematic diagram.

5-5. Each circuit-board mounted component is identified on an illustration of the circuit board which also shows the etched wiring. These illustrations appear in Section VII with their schematics. The reference designation of each component mounted on a circuit board should be prefixed by the assembly number to form a complete designation; for example, A3R11.

**5-6. TEST EQUIPMENT REQUIRED**

5-7. Instruments required to perform the operations in this section are listed in Table 5-2. This table lists the type of equipment required, critical specifications, use, and recommended model or type. For operating instructions refer to the manual supplied with the equipment. If the equipment listed is not available, equipment which meets or exceeds the critical specifications may be used.

**5-8. PERFORMANCE CHECKS**

5-9. The performance checks provided in Table 5-3 verify the 4800A operation to be within specifications (refer to Section I, Table 1-1). The performance checks may be used:

- a. As part of incoming inspection
- b. For monthly routine reliability checks
- c. Before returning to regular service after completed repairs.
- d. As part of troubleshooting to locate malfunctioning circuits.

5-10. A sample Performance Check Test Card is included in this section. The card may be duplicated and completed during 4800A Performance Checks to provide a permanent record.

*Table 5-1. Schematics and Circuit Board Illustrations*

Assy No	Designation	Schematic Diagram and Circuit Board Parts Location Figure No.
A1	Utility Amplifier	7-5
A2	Utility Amplifier	7-5
A3	Bandpass Filter	7-5
A4	Utility Amplifier	7-5
A5	Detector (meter)	7-6
A6	Filter Amplifier	7-7
A7	Schmitt Trigger	7-7
A8	Phase Detector	7-7
A9	Utility Amplifier	7-4
A10	Bandpass Filter	7-4
A11	Utility Amplifier	7-4
A12	Detector (ALC)	7-6
A13	Filter Amplifier	7-7
A14	DC Amplifier	7-6
A15	Analog Outputs	7-9
A16	Oscillator Amp	7-2
A17	AGC and Monitor Amplifier	7-2
A18	20 Volt Regulator	7-8
A19	Rectifier and 14 Volt Regulators	7-8
A20	Magnitude Range Switch Assembly	7-3
A21	Oscillator Switch Assembly	7-2
A22	Variable Capacitor Assembly	7-2
A23	Direct Measurement Plug-in (Model 4801A)	7-3

Table 5-2. Recommended Test Equipment and Accessories

Instrument or Accessory Type	Critical Specifications	Use	Recommended Instrument or Accessory
DC Voltmeter	Voltage range: 1 mV to 100 V full scale	Performance Checks Adjustments Troubleshooting	-hp Model 412A DC Voltmeter, ohmmeter, ammeter
Oscilloscope	Frequency range: to 20 MHz Sensitivity: to 10 pV/cm Sweep speeds to 50 ns/cm	Troubleshooting	-hp- Model 140A Oscilloscope W/1420A Time Base and 1402A Dual Trace Amplifier
Electronic Counter	Frequency range: S HZ to 500 kHz	Performance Checks Adjustments	-hp- Model 5245L Electronic Counter
AC Voltmeter	Range: 1.0 mV to 300 volts full scale, Accuracy: * 1% of full scale	Adjustments Troubleshooting	-hp- Model 400E AC Voltmeter
Ohmmeter	Resistance Range: 0.1 ohm to 1000 megohms	Troubleshooting	-hp Model 412A DC Voltmeter, Ohmmeter, Ammeter
Variable Transformer	Output 115V *20% or 230 V ± 20% Current: 2 amperes	Adjustments Troubleshooting	General Radio Type W10M3TA
Inductor	10 millenaries with a Q greater than 100	Performance Checks	-hp- Stock No. 103A41
Resistor	100 ohms 0.1%	Adjustments	-hp Stock No. 0698-4343
Calibration Resistor	1 K ohms *0.25%	Performance Checks Adjustments Troubleshooting	-hp- Stock No. 13525A(Supplied Accessory)
Resistor	10 K ohms *0.1%	Adjustments	-hp- Stock No. 0698-4157
Decade Resistor	0 - 1 K ohms ± 0.1% in 100 ohm steps	Performance Checks	General Radio Type 510D
Decade Resistor	0 - 10 K ohms +0.1% in 1000 ohm steps	Performance Checks	General Radio Type 510E
Capacitor	0.1 , pF *0.1%	Performance Checks	General Radio Type 1409-T
Capacitor	0.01 pF *0.1%	Adjustments	General Radio Type 1409-L
Capacitor	0.001 pF * 0.1%	Performance Checks	General Radio Type 1409-F
Circuit Board Extender	15 pin fitted with connector to extend circuit board assemblies	Adjustments Troubleshooting	-hp- Stock No. 5060-0049(Supplied Accessory)

Table 5-3. Performance Checks

1. FREQUENCY ACCURACY

SPECIFICATIONS: X1 ±2% at "LC", ±4% at all other points.

X10 - X10K ±1% at "LC", ±2% at all other points.

This procedure is used to verify frequency accuracy at the three most critical dial settings. Proceed as follows:

- a. Connect frequency counter to **FREQ MON** connector on rear panel. Set counter to read period. Set **Z RANGE** to **X1K**.
- b. Set **FREQUENCY RANGE** to **X1** and **FREQUENCY** dial to "5".
- c. Compare counter reading with limits listed below.
- d. Change **FREQUENCY RANGE** to **X10**, **X100**, **X1K** and **X10K** while comparing counter readings with limits listed below (Change counter to read **FREQUENCY** on **X1K** and **X10K** ranges).
- e. Change **FREQUENCY** dial to "LC" (15.92) and **FREQUENCY RANGE** to **X1**. Check limits listed below.
- f. Check limits on **X10**, **X100**, **X1K** and **X10K** ranges.
- g. Repeat above procedure for **FREQUENCY** dial setting of "50".

FREQUENCY RANGE (Hz)	FREQUENCY dial setting					
	5		LC (15.92)		50	
	low limit	high limit	low limit	high limit	low limit	high limit
X1	208.0 ms	192.0 ms	64.09 ms	61.57 ms	20.8 ms	19.6 ms
X10	20.4 ms	19.6 ms	6.346 ms	6.22 ms	2.04 ms	1.96 ms
X100	2.04 ms	1.96 ms	634.6 μs	622 μs	204 μs	196 μs
X1K	4.90 kHz	5.1 kHz	15.61 kHz	16.25 kHz	49 kHz	51 kHz
X10K	49 kHz	51 kHz	156.1 kHz	162.5 kHz	490 kHz	510 kHz

2. IMPEDANCE MEASUREMENT ACCURACY

SPECIFICATIONS: ±5% of reading.

This procedure verifies the impedance measurement accuracy of the 4800A. Proceed as follows:

- a. Insert 1 K ohm Calibration resistor in **DIRECT MEASUREMENT PLUG-in** terminals.

Table 5-3. Performance Checks (Cont)

b. Set 4800A controls as follows:

Z RANGE X100

FREQUENCY dial 10

- c. Change FREQUENCY RANGE from X1 to X10K; Z MAGNITUDE meter should indicate 1 K ohm  $\pm 5\%$  on all ranges.
- d. Set Z RANGE to X1K. Change FREQUENCY RANGE from X1 to X1K; Z MAGNITUDE meter should indicate 1 K ohm  $\pm 5\%$  on all ranges.
- e. Replace 1 K ohm Calibration resistor with a 0.1  $\mu$ F capacitor.
- f. Set FREQUENCY dial to "LC" (15.92). Change Z RANGE and FREQUENCY RANGE as indicated below to check scale accuracy of individual ranges. Monitor frequency with electronic counter connected to FREQ MON connector. Adjust FREQUENCY dial for indicated period or frequency.

Z RANGE	FRE- QUENCY RANGE	TEST SIGNAL PERIOD OR FREQ	Z MAGNITUDE METER INDICATION
X1	X10K	159.2 kHz	10 $\pm 5\%$
X10	X10K	159.2 kHz	10 $\pm 5\%$
X10	X1K	15.92 kHz	100 $\pm 5\%$
X100	X1K	15.92 kHz	100 $\pm 5\%$
X100	X100	628.3 $\mu$ s	1K $\pm 5\%$
X1K	X100	628.3 $\mu$ s	1K $\pm 5\%$
X1K	X10	6.283 ms	10K $\pm 5\%$
X10K	X10	6.283 ms	10K $\pm 5\%$
X10K	X1	62.83 ms	100K $\pm 5\%$
X100K	X1	62.83 ms	100K $\pm 5\%$

- g. Replace 0.1  $\mu$ F capacitor with a 0.001  $\mu$ F capacitor; set Z RANGE and FREQUENCY RANGE as indicated below. Continue to monitor period of test frequency.

Z RANGE	FRE- QUENCY RANGE	TEST SIGNAL PERIOD OR FREQ	Z MAGNITUDE METER INDICATION
X100K	X10	6.283 ms	1M $\pm 5\%$
X1M	X10	6.283 ms	1M $\pm 5\%$
X1M	X1	62.83 ms	10M $\pm 5\%$

Table 5-3. Performance Checks (Cont)

h.	Z MAGNITUDE TRACKING CHECK
1.	Set Z RANGE to X100, FREQUENCY RANGE to X100, and FREQUENCY dial to 10.
2.	Connect decade resistor to measurement terminals and set to 1 K ohm.
3.	Decrease decade resistor in 100 ohm steps while noting Z meter <i>readings</i> .
4.	Set decade resistor to 1 K ohm and Z RANGE to X1K.
5.	Increase decade resistor in 1 K ohm steps while noting Z meter readings.
6.	The error at any setting should not exceed $\pm 5\%$ of reading.
3.	PHASE ANGLE MEASUREMENT ACCURACY SPECIFICATIONS: + 60 This procedure verifies 4800A phase angle measurement accuracy. Proceed as follows:
<b>NOTE</b>	
At very low frequencies such as 5 Hz, it is normal for the phase meter to oscillate around the proper reading.	
a.	Connect 1 K ohm Calibration <i>resistor to measurement terminals</i> .
b.	Set 4800A controls as follows: Z RANGE                   X100 FREQUENCY RANGE       X1 FREQUENCY dial         5
c.	PHASE ANGLE meter should indicate $0^\circ +60$ . Change FREQUENCY RANGE from X1 to X10K; meter should remain within + 60
d.	Connect 0.01 pF capacitor to measurement terminals.
e.	Set 4800A controls as follows: Z RANGE                   X100 FREQUENCY RANGE       X1K FREQUENCY dial         "LC" (15.92)
f.	PHASE ANGLE meter should indicate $-900 \pm 60$ .



Table 5-3. Performance Checks (Cont)

- g. Replace 0.01 MF capacitor with a 10 mH inductor; PHASE ANGLE meter should indicate  $+900 \pm 6^\circ$ .

**NOTE**

For low Q inductors, the PHASE ANGLE meter will read slightly low ( $\theta = \arctan Q$ ).

4. a. **FREQ OUTPUT**
1. Connect DC voltmeter, set to 1 V range, to FREQ connector.
  2. DC output should be approximately 1 V at 50 on dial, decreasing with dial rotation.
- b. **MAGNITUDE OUTPUT**
1. Connect DC voltmeter, set to 1 V range, to MAGNITUDE output connector.
  2. Set 4800A controls as follows:
 

Z RANGE	10K
FREQUENCY RANGE	X100
FREQUENCY dial	10
  3. Connect 10 K ohm resistor to measurement terminals.
  4. DC output should be adjustable to 1.0 V with MAGNITUDE LEVEL ADJ.
- c. **PHASE OUTPUT**
1. Connect DC voltmeter, set to 1 V range, to PHASE output connector.
  2. Set 4800A controls as in b-2 above.
  3. Connect 0.01 /F capacitor to measurement terminals.
  4. DC output should be adjustable to -0.9 V with PHASE LEVEL ADJ.

Performance Check Test Card

<p><b>1. FREQUENCY</b></p> <p>1. a - e</p> <table border="1" style="width: 100%; border-collapse: collapse;"> <thead> <tr> <th>Z RANGE</th> <th>DIAL</th> <th>MIN</th> <th>ACT</th> <th>MAX</th> </tr> </thead> <tbody> <tr> <td>X1</td> <td>"LC"</td> <td>-2%</td> <td>_____</td> <td>+2%</td> </tr> <tr> <td>X1</td> <td>elsewhere</td> <td>-4%</td> <td>_____</td> <td>+4%</td> </tr> <tr> <td>X10 - X10K</td> <td>"LC"</td> <td>-1%</td> <td>_____</td> <td>+1%</td> </tr> <tr> <td>X10 - X10K</td> <td>elsewhere</td> <td>-2%</td> <td>_____</td> <td>+2%</td> </tr> </tbody> </table> <p><b>2. IMPEDANCE</b></p> <p>2. a - d</p> <table border="1" style="width: 100%; border-collapse: collapse;"> <thead> <tr> <th>Z RANGE</th> <th>FREQ</th> <th>MIN</th> <th>ACT</th> <th>MAX</th> </tr> </thead> <tbody> <tr> <td>X100</td> <td>all</td> <td>950 Ω</td> <td>_____</td> <td>1.05 KΩ</td> </tr> <tr> <td>X1K</td> <td>all</td> <td>950 Ω</td> <td>_____</td> <td>1.05 KΩ</td> </tr> </tbody> </table> <p>2. e - g</p> <table border="1" style="width: 100%; border-collapse: collapse;"> <thead> <tr> <th>Z RANGE</th> <th>READING</th> <th>MIN</th> <th>ACT</th> <th>MAX</th> </tr> </thead> <tbody> <tr> <td>X1</td> <td>FS</td> <td>9.5 Ω</td> <td>_____</td> <td>10.5 Ω</td> </tr> <tr> <td>X10</td> <td>1/10 FS</td> <td>9.5 Ω</td> <td>_____</td> <td>10.5 Ω</td> </tr> <tr> <td>X10</td> <td>FS</td> <td>95 Ω</td> <td>_____</td> <td>105 Ω</td> </tr> <tr> <td>X100</td> <td>1/10 FS</td> <td>95 Ω</td> <td>_____</td> <td>105 Ω</td> </tr> <tr> <td>X100</td> <td>FS</td> <td>950 Ω</td> <td>_____</td> <td>1.05 KΩ</td> </tr> <tr> <td>X1K</td> <td>1/10 FS</td> <td>950 Ω</td> <td>_____</td> <td>1.05 KΩ</td> </tr> <tr> <td>X1K</td> <td>FS</td> <td>9.5 KΩ</td> <td>_____</td> <td>10.5 KΩ</td> </tr> <tr> <td>X10K</td> <td>1/10 FS</td> <td>9.5 KΩ</td> <td>_____</td> <td>10.5 KΩ</td> </tr> <tr> <td>X10K</td> <td>FS</td> <td>95 KΩ</td> <td>_____</td> <td>105 KΩ</td> </tr> <tr> <td>X100K</td> <td>1/10 FS</td> <td>95 KΩ</td> <td>_____</td> <td>105 KΩ</td> </tr> <tr> <td>X100K</td> <td>FS</td> <td>950 KΩ</td> <td>_____</td> <td>1.05 MΩ</td> </tr> <tr> <td>X1M</td> <td>1/10 FS</td> <td>950 KΩ</td> <td>_____</td> <td>1.05 MΩ</td> </tr> <tr> <td>X1M</td> <td>FS</td> <td>9.5 MΩ</td> <td>_____</td> <td>10.5 MΩ</td> </tr> </tbody> </table> <p>2. h</p> <table border="1" style="width: 100%; border-collapse: collapse;"> <thead> <tr> <th>RESISTOR</th> <th>Z RANGE</th> <th>MIN</th> <th>ACT</th> <th>MAX</th> </tr> </thead> <tbody> <tr> <td>1 KΩ</td> <td>X100</td> <td>950 Ω</td> <td>_____</td> <td>1.05 KΩ</td> </tr> <tr> <td>900 Ω</td> <td></td> <td>855 Ω</td> <td>_____</td> <td>945 Ω</td> </tr> <tr> <td>800 Ω</td> <td></td> <td>760 Ω</td> <td>_____</td> <td>840 Ω</td> </tr> <tr> <td>700 Ω</td> <td></td> <td>665 Ω</td> <td>_____</td> <td>735 Ω</td> </tr> </tbody> </table>					Z RANGE	DIAL	MIN	ACT	MAX	X1	"LC"	-2%	_____	+2%	X1	elsewhere	-4%	_____	+4%	X10 - X10K	"LC"	-1%	_____	+1%	X10 - X10K	elsewhere	-2%	_____	+2%	Z RANGE	FREQ	MIN	ACT	MAX	X100	all	950 Ω	_____	1.05 KΩ	X1K	all	950 Ω	_____	1.05 KΩ	Z RANGE	READING	MIN	ACT	MAX	X1	FS	9.5 Ω	_____	10.5 Ω	X10	1/10 FS	9.5 Ω	_____	10.5 Ω	X10	FS	95 Ω	_____	105 Ω	X100	1/10 FS	95 Ω	_____	105 Ω	X100	FS	950 Ω	_____	1.05 KΩ	X1K	1/10 FS	950 Ω	_____	1.05 KΩ	X1K	FS	9.5 KΩ	_____	10.5 KΩ	X10K	1/10 FS	9.5 KΩ	_____	10.5 KΩ	X10K	FS	95 KΩ	_____	105 KΩ	X100K	1/10 FS	95 KΩ	_____	105 KΩ	X100K	FS	950 KΩ	_____	1.05 MΩ	X1M	1/10 FS	950 KΩ	_____	1.05 MΩ	X1M	FS	9.5 MΩ	_____	10.5 MΩ	RESISTOR	Z RANGE	MIN	ACT	MAX	1 KΩ	X100	950 Ω	_____	1.05 KΩ	900 Ω		855 Ω	_____	945 Ω	800 Ω		760 Ω	_____	840 Ω	700 Ω		665 Ω	_____	735 Ω	<table border="1" style="width: 100%; border-collapse: collapse;"> <thead> <tr> <th>RESISTOR</th> <th>Z RANGE</th> <th>MIN</th> <th>ACT</th> <th>MAX</th> </tr> </thead> <tbody> <tr> <td>600 Ω</td> <td rowspan="10" style="text-align: center; vertical-align: middle;">X1K</td> <td>570 Ω</td> <td>_____</td> <td>630 Ω</td> </tr> <tr> <td>500 Ω</td> <td>475 Ω</td> <td>_____</td> <td>525 Ω</td> </tr> <tr> <td>400 Ω</td> <td>380 Ω</td> <td>_____</td> <td>420 Ω</td> </tr> <tr> <td>300 Ω</td> <td>285 Ω</td> <td>_____</td> <td>315 Ω</td> </tr> <tr> <td>200 Ω</td> <td>190 Ω</td> <td>_____</td> <td>210 Ω</td> </tr> <tr> <td>100 Ω</td> <td>95 Ω</td> <td>_____</td> <td>105 Ω</td> </tr> <tr> <td>1 KΩ</td> <td>950 Ω</td> <td>_____</td> <td>1.05 KΩ</td> </tr> <tr> <td>2 KΩ</td> <td>1.9 KΩ</td> <td>_____</td> <td>2.1 KΩ</td> </tr> <tr> <td>3 KΩ</td> <td>2.85 KΩ</td> <td>_____</td> <td>3.15 KΩ</td> </tr> <tr> <td>4 KΩ</td> <td>3.85 KΩ</td> <td>_____</td> <td>4.2 KΩ</td> </tr> <tr> <td>5 KΩ</td> <td>4.75 KΩ</td> <td>_____</td> <td>5.25 KΩ</td> </tr> <tr> <td>6 KΩ</td> <td>5.7 KΩ</td> <td>_____</td> <td>6.3 KΩ</td> </tr> <tr> <td>7 KΩ</td> <td>6.65 KΩ</td> <td>_____</td> <td>7.35 KΩ</td> </tr> <tr> <td>8 KΩ</td> <td>7.6 KΩ</td> <td>_____</td> <td>8.4 KΩ</td> </tr> <tr> <td>9 KΩ</td> <td>8.55 KΩ</td> <td>_____</td> <td>9.45 KΩ</td> </tr> <tr> <td>10 KΩ</td> <td>9.5 KΩ</td> <td>_____</td> <td>10.5 KΩ</td> </tr> </tbody> </table> <p><b>3. PHASE ANGLE</b></p> <p>3. a - c</p> <table border="1" style="width: 100%; border-collapse: collapse;"> <thead> <tr> <th>COMPONENT</th> <th>FREQ</th> <th>MIN</th> <th>ACT</th> <th>MAX</th> </tr> </thead> <tbody> <tr> <td>resistor</td> <td>all</td> <td>-6°</td> <td>_____</td> <td>+6°</td> </tr> </tbody> </table> <p>3. d - f</p> <table border="1" style="width: 100%; border-collapse: collapse;"> <tbody> <tr> <td>0.01 μF cap</td> <td>15.92 kHz</td> <td>-84°</td> <td>_____</td> <td>+96°</td> </tr> </tbody> </table> <p>3. g</p> <table border="1" style="width: 100%; border-collapse: collapse;"> <tbody> <tr> <td>10 mH coil</td> <td>15.92 kHz</td> <td>+84°</td> <td>_____</td> <td>+95°</td> </tr> </tbody> </table> <p><b>4. ANALOG OUTPUTS</b></p> <p>4.a. 1 - 2</p> <table border="1" style="width: 100%; border-collapse: collapse;"> <tbody> <tr> <td>FREQ - 1 V at "50" decreasing with dial rotation</td> <td>_____</td> </tr> </tbody> </table> <p>4.b. 1 - 3</p> <table border="1" style="width: 100%; border-collapse: collapse;"> <tbody> <tr> <td>MAGNITUDE - Adjusts to 1 V</td> <td>_____</td> </tr> </tbody> </table> <p>4.c. 1 - 3</p> <table border="1" style="width: 100%; border-collapse: collapse;"> <tbody> <tr> <td>PHASE - Adjusts to -0.9 V</td> <td>_____</td> </tr> </tbody> </table>					RESISTOR	Z RANGE	MIN	ACT	MAX	600 Ω	X1K	570 Ω	_____	630 Ω	500 Ω	475 Ω	_____	525 Ω	400 Ω	380 Ω	_____	420 Ω	300 Ω	285 Ω	_____	315 Ω	200 Ω	190 Ω	_____	210 Ω	100 Ω	95 Ω	_____	105 Ω	1 KΩ	950 Ω	_____	1.05 KΩ	2 KΩ	1.9 KΩ	_____	2.1 KΩ	3 KΩ	2.85 KΩ	_____	3.15 KΩ	4 KΩ	3.85 KΩ	_____	4.2 KΩ	5 KΩ	4.75 KΩ	_____	5.25 KΩ	6 KΩ	5.7 KΩ	_____	6.3 KΩ	7 KΩ	6.65 KΩ	_____	7.35 KΩ	8 KΩ	7.6 KΩ	_____	8.4 KΩ	9 KΩ	8.55 KΩ	_____	9.45 KΩ	10 KΩ	9.5 KΩ	_____	10.5 KΩ	COMPONENT	FREQ	MIN	ACT	MAX	resistor	all	-6°	_____	+6°	0.01 μF cap	15.92 kHz	-84°	_____	+96°	10 mH coil	15.92 kHz	+84°	_____	+95°	FREQ - 1 V at "50" decreasing with dial rotation	_____	MAGNITUDE - Adjusts to 1 V	_____	PHASE - Adjusts to -0.9 V	_____
Z RANGE	DIAL	MIN	ACT	MAX																																																																																																																																																																																																																																												
X1	"LC"	-2%	_____	+2%																																																																																																																																																																																																																																												
X1	elsewhere	-4%	_____	+4%																																																																																																																																																																																																																																												
X10 - X10K	"LC"	-1%	_____	+1%																																																																																																																																																																																																																																												
X10 - X10K	elsewhere	-2%	_____	+2%																																																																																																																																																																																																																																												
Z RANGE	FREQ	MIN	ACT	MAX																																																																																																																																																																																																																																												
X100	all	950 Ω	_____	1.05 KΩ																																																																																																																																																																																																																																												
X1K	all	950 Ω	_____	1.05 KΩ																																																																																																																																																																																																																																												
Z RANGE	READING	MIN	ACT	MAX																																																																																																																																																																																																																																												
X1	FS	9.5 Ω	_____	10.5 Ω																																																																																																																																																																																																																																												
X10	1/10 FS	9.5 Ω	_____	10.5 Ω																																																																																																																																																																																																																																												
X10	FS	95 Ω	_____	105 Ω																																																																																																																																																																																																																																												
X100	1/10 FS	95 Ω	_____	105 Ω																																																																																																																																																																																																																																												
X100	FS	950 Ω	_____	1.05 KΩ																																																																																																																																																																																																																																												
X1K	1/10 FS	950 Ω	_____	1.05 KΩ																																																																																																																																																																																																																																												
X1K	FS	9.5 KΩ	_____	10.5 KΩ																																																																																																																																																																																																																																												
X10K	1/10 FS	9.5 KΩ	_____	10.5 KΩ																																																																																																																																																																																																																																												
X10K	FS	95 KΩ	_____	105 KΩ																																																																																																																																																																																																																																												
X100K	1/10 FS	95 KΩ	_____	105 KΩ																																																																																																																																																																																																																																												
X100K	FS	950 KΩ	_____	1.05 MΩ																																																																																																																																																																																																																																												
X1M	1/10 FS	950 KΩ	_____	1.05 MΩ																																																																																																																																																																																																																																												
X1M	FS	9.5 MΩ	_____	10.5 MΩ																																																																																																																																																																																																																																												
RESISTOR	Z RANGE	MIN	ACT	MAX																																																																																																																																																																																																																																												
1 KΩ	X100	950 Ω	_____	1.05 KΩ																																																																																																																																																																																																																																												
900 Ω		855 Ω	_____	945 Ω																																																																																																																																																																																																																																												
800 Ω		760 Ω	_____	840 Ω																																																																																																																																																																																																																																												
700 Ω		665 Ω	_____	735 Ω																																																																																																																																																																																																																																												
RESISTOR	Z RANGE	MIN	ACT	MAX																																																																																																																																																																																																																																												
600 Ω	X1K	570 Ω	_____	630 Ω																																																																																																																																																																																																																																												
500 Ω		475 Ω	_____	525 Ω																																																																																																																																																																																																																																												
400 Ω		380 Ω	_____	420 Ω																																																																																																																																																																																																																																												
300 Ω		285 Ω	_____	315 Ω																																																																																																																																																																																																																																												
200 Ω		190 Ω	_____	210 Ω																																																																																																																																																																																																																																												
100 Ω		95 Ω	_____	105 Ω																																																																																																																																																																																																																																												
1 KΩ		950 Ω	_____	1.05 KΩ																																																																																																																																																																																																																																												
2 KΩ		1.9 KΩ	_____	2.1 KΩ																																																																																																																																																																																																																																												
3 KΩ		2.85 KΩ	_____	3.15 KΩ																																																																																																																																																																																																																																												
4 KΩ		3.85 KΩ	_____	4.2 KΩ																																																																																																																																																																																																																																												
5 KΩ	4.75 KΩ	_____	5.25 KΩ																																																																																																																																																																																																																																													
6 KΩ	5.7 KΩ	_____	6.3 KΩ																																																																																																																																																																																																																																													
7 KΩ	6.65 KΩ	_____	7.35 KΩ																																																																																																																																																																																																																																													
8 KΩ	7.6 KΩ	_____	8.4 KΩ																																																																																																																																																																																																																																													
9 KΩ	8.55 KΩ	_____	9.45 KΩ																																																																																																																																																																																																																																													
10 KΩ	9.5 KΩ	_____	10.5 KΩ																																																																																																																																																																																																																																													
COMPONENT	FREQ	MIN	ACT	MAX																																																																																																																																																																																																																																												
resistor	all	-6°	_____	+6°																																																																																																																																																																																																																																												
0.01 μF cap	15.92 kHz	-84°	_____	+96°																																																																																																																																																																																																																																												
10 mH coil	15.92 kHz	+84°	_____	+95°																																																																																																																																																																																																																																												
FREQ - 1 V at "50" decreasing with dial rotation	_____																																																																																																																																																																																																																																															
MAGNITUDE - Adjusts to 1 V	_____																																																																																																																																																																																																																																															
PHASE - Adjusts to -0.9 V	_____																																																																																																																																																																																																																																															

Figure 5-2. Performance Check Test Card

**5-11. ADJUSTMENT PROCEDURES**

5-12. The following adjustment procedures should be performed only if it has been determined by the Performance Checks given in Table 5-3 that the 4800A is not within specifications. Tolerances associated with adjustments are given as aids to making the adjustments. These tolerances do not constitute a basis for qualification or acceptance of an instrument since no allowance has been made for temperature or aging effects. Qualification and overall performance should be based on the specification listed in Table 1-1.

**NOTE**

Except where indicated, adjustments and tests are made at nominal line voltage. Access to adjustments may require use of the supplied plug-in extender.

**CAUTION**

Remove all power to the 4800A before removing or replacing plug-in assemblies.

**5-13. COVER REMOVAL.** To remove top or cover, remove four phillips-head screws. Slide cover approximately 1/2 inch towards rear of chassis and lift free. To replace cover, reverse removal procedure.

**5-14. METER MECHANICAL ADJUSTMENT.** This procedure sets the zero of the Phase Angle meter.

**NOTE**

The Z MAGNITUDE meter is factory adjusted and does not require any mechanical adjustment.

- a. Remove power from 4800A.
- b. Rotate meter zero adjustment screw clockwise until the meter pointer is to the left of zero and moving towards zero.
- c. Continue to rotate adjustment screw clockwise until the meter pointer is exactly on zero. If pointer moves past zero, repeat steps b and c.

**5-15. POWER SUPPLIES.** This procedure adjusts the  $\pm 20$  V supply to the proper level. There are no adjustments for the other power supplies. Proceed as follows:

- a. Adjust +20 V Adjust A18R16 for +20, 0.1 Vat A9 (10). Tap A18 assembly with a pencil. If voltage changes, readjust A18R16 as required. Continue

tapping and readjusting until voltage becomes stable within :0.1 V.

- b. Check other power supply voltages listed below (see Figure 5-3 for test points).

-20 -0.1 V	XA9(7)
-14 +1 V (A)	XA23(9)
-14 $\pm 1$ V (B)	XA23(6)
+14+1 V	XA23(11)

**NOTE**

-14 (A) and -14 (B) are two separate supplies.

- c. Adjust line voltage from 102 V to 128 V. There should not be any noticeable change of the 20 V power supplies.

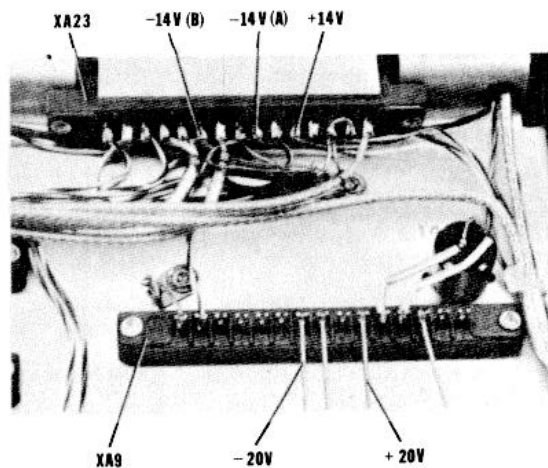

Figure 5-3. Power Supply Test Points

**5-16. OSCILLATOR OUTPUT LEVEL.** This procedure adjusts the oscillator signal to the proper level. Proceed as follows:

- a. Remove jumper between INT OSC and EXT OSC IN connectors.
- b. Connect AC voltmeter to INT OSC connector.
- c. AC voltmeter should read between 0.72 V and 0.88 V.
- d. If reading is outside these limits, adjust Oscillator Output Adjust A16R20 for 0.8 V reading.
- e. Replace jumper.

**5-17. OSCILLATOR FREQUENCY.** This procedure adjusts the oscillator frequency to correspond with the front panel dial setting.

DC between A14TP1 and A14TP2 as measured from the TP's to ground.

- a. Set 4800A controls as follows:  
 FREQUENCY RANGE X100  
 FREQUENCY dial LC (15.92)
- b. Set counter to read X100 Iriond and connect to FREQ MON connector.
- c. Adjust FREQUENCY dial for a reading of 628.3 /s as indicated by counter.
- d. Remove FREQUENCY dial knob; loosen two screws securing dial and position "LC" mark (15.92) under fiducial hairline. Tighten screws and replace knob.
- e. Change FREQUENCY RANGE to X10K and counter function to frequency.
- f. Adjust HF Comp A16C1 for 159.2 kHz (oscillator cover must be on while taking reading).
- g. Check FREQUENCY dial accuracy on X1range. Readings should be within 2 when dial is adjusted to "LC" mark and i4% at all other settings. On X10 - X10K ranges readings should be within ±1% at "LC" and ±2% at all other settings.

**5-18. 4801A DC BIAS.** This procedure adjusts the base voltage of Q7 to zero volts with no component on the measurement terminals.

- a. Set Z RANGE to X100 and remove jumper on rear panel.
- b. Connect DC voltmeter to the current sensing terminal (J2).
- c. Adjust DC BIAS R16 in 4801A for 0 V +5 mV.
- d. Measure voltage on voltage sensing terminal (J1).
- e. If greater than +10 mV DC, select a value for 4801A R1 which produces a reading less than +10 mV.

**5-19. ALC ADJUSTMENTS.** This procedure balances the differential amplifier Q5 and Q6 in DC Amplifier A14.

- a. Set 4800A controls as follows:  
 Z RANGE X10K  
 FREQUENCY RANGE X100  
 FREQUENCY dial 10
- b. Remove jumper on rear panel and place A14 circuit board on supplied board extender.
- c. Short A14TP3 and A14TP4 together.
- d. Adjust DC Balance A14R18 for 0 V +0.25 V

**NOTE**

Do not connect meter between A14TP1 and A14TP2 as this will cause an incorrect reading.

- e. Replace jumper and A14 assembly.

**5-20. CHANNEL GAIN EQUALIZATION.** This procedure adjusts the voltage channel gain to be exactly equal to the current channel gain.

- a. Set 4800A controls as follows:

Z RANGE X10K  
 FREQUENCY RANGE X100  
 FREQUENCY dial 10

- b. Connect 10 K ohm resistor to measurement terminals.
- c. If Z MAGNITUDE meter is off scale, adjust ALC Ref A14R25 for a reading of 9.6.
- d. Change Z RANGE to X10 and resistor to 100 ohms.
- e. If reading has changed, adjust Channel Gain Equalization Adjust R2 for half of the difference.
- f. Repeat steps a through e.

**5-21. FULL SCALE Z.** This procedure adjusts the full scale accuracy of the Z MAGNITUDE meter.

- a. Set 4800A controls as follows:

Z RANGE X10  
 FREQUENCY RANGE X100  
 FREQUENCY dial 10

- b. Connect 100 ohm resistor to measurement terminals.
- c. Adjust ALC Ref A14R25 for a reading of 10.0 on Z MAGNITUDE meter.

**5-22. 1/10 FULL SCALE Z.** This procedure adjusts the 1/10 full scale accuracy of the Z MAGNITUDE meter.

- a. Set 4800A controls as follows:

Z RANGE X100  
 FREQUENCY RANGE X100  
 FREQUENCY dial 10

b. Select a value for A5R21 which produces a reading of 1.0 on Z MAGNITUDE meter (left end of scale).

**5-23. PHASE TRIGGER LEVELS.** This procedure adjusts the voltage and current channel Schmitt Triggers to trigger at zero volts on the positive slope of the signal.

- a. Set 4800A controls as follows:  
 Z RANGE X100  
 FREQUENCY RANGE X100  
 FREQUENCY dial 10
- b. Connect 1 K ohm Calibration resistor to measurement terminals.
- c. Note reading on PHASE ANGLE meter.
- d. Change resistor to 100 ohm.
- e. Adjust Voltage Channel Trigger Level Adjust A7R7 for the same reading noted in step c.
- f. Change Z RANGE to X10K.
- g. Connect 1 K ohm Calibration resistor to measurement terminals.
- h. Note reading on PHASE ANGLE meter.
- i. Change resistor to 10 K ohm.
- j. Adjust Current Channel Trigger Level Adjust A7R16 for the same reading noted in step h.

**5-24. PHASE ZERO AND FULL SCALE.** This procedure adjusts the electrical zero and full scale accuracy of the PHASE ANGLE meter.

- a. Set 4800A controls as follows:  
 Z RANGE X1K  
 FREQUENCY RANGE X100
- b. Connect 1 K ohm Calibration resistor to measurement terminals.
- c. Adjust Phase Zero Adj A8R16 for 0° on PHASE ANGLE meter.
- d. Change 4800A controls as follows:  
 Z RANGE X100  
 FREQUENCY RANGE X1K  
 FREQUENCY dial "LC" (15.92)
- e. Connect 0.01 uF capacitor to measurement terminals.
- f. Adjust Phase Cal A8R19 for -900 on PHASE ANGLE meter.

**5-25. PHASE SHIFT COMPENSATION.** This

procedure minimizes low frequency phase difference between channels and neutralizes the input capacitance of the differential amplifier Q1, Q2, Q4, and Q5 in the 4801A.

- a. Set 4800A controls as follows:  
 Z RANGE X1K  
 FREQUENCY RANGE X1  
 FREQUENCY dial 5
- b. Connect 1 K ohm Calibration resistor to measurement terminals.
- c. Adjust 5 Hz Phase Adjust R3 (on chassis between A12 and A13) for 0 on PHASE ANGLE meter.

**NOTE**

Meter should swing approximately 40 on both sides of 00. If R3 does not have sufficient range, interchange utility amplifiers between channels two at a time until the adjustment is within the range of R3.

- d. Change 4800A controls as follows:  
 FREQUENCY RANGE X10K  
 FREQUENCY dial 50
- e. Note reading on PHASE ANGLE meter.
- f. Change Z RANGE to X100.
- g. Adjust HF Phase Adjust C1 in 4801A for the same reading noted in step e.
- h. If phase error is greater than +30, select a value for C2 (at XA13) that will produce an error less than +30 (usually between 33 pF and 39 pF).

**5-26. TROUBLESHOOTING PROCEDURES**

5-27. This section contains information and procedures to aid in isolating malfunctions. Troubleshooting should be undertaken only after it has been determined that the malfunction cannot be corrected by performing the Adjustment Procedures.

**5-28. SYSTEM TROUBLESHOOTING.** The troubleshooting trees shown in Figures 5-5 through 5-8 are a logical diagnosis of symptoms, and several specific front-panel symptoms. It must be emphasized that the trees are not a strict elimination procedure, and that other circuits than those listed can be at fault. The trees are based on the assumption that only one particular circuit is at fault.

**NOTE**

When observing front panel indications, if there is a large Z MAGNITUDE error, there may also be a PHASE ANGLE error. This should be considered only a Z MAGNITUDE malfunction for troubleshooting purposes.

5-29. To use the troubleshooting trees, first determine the symptoms of the malfunction by using the Performance Checks in Table 5-3. Then select the appropriate trees according to the symptoms observed. At each point where a decision has been made there is a number. This number corresponds to a similarly numbered comment which aids in understanding the logic of the troubleshooting tree.

**5-30. SECTIONAL TROUBLESHOOTING.** Sectional troubleshooting is performed after the malfunction has been isolated to a particular 4800A assembly. Refer to the applicable schematic diagram (Figures 7-2 through 7-9) and compare assembly waveforms and voltages to those shown on the schematic. The schematic measurements should not be considered performance specifications since they may vary with component tolerances, aging, and temperature. They are provided only to assist troubleshooting.

5-31. When in-circuit testing a transistor stage, first determine if the emitter-base junction is properly biased. Do not place an electronic voltmeter directly across the junction to measure the voltage difference; there could be sufficient loop current between the voltmeter leads to damage the transistor. Instead, measure each voltage separately with respect to a common point (e.g., chassis). If junction is not properly biased and power supply voltages are known to be correct, the base-emitter junction may be open.

5-32. If the emitter-base junction is forward-biased, check for amplifier action by short-circuiting base to emitter while observing collector voltage. The short eliminates base-emitter bias and should cause the transistor to stop conduction. Collector voltage will then change to near the supply in most circuits. Any difference is due to leakage current through the transistor, and in general, the smaller this current, the better the transistor. If the collector voltage does not change, the transistor either has an emitter-collector short or emitter-base open circuit.

5-33. If a short or open is suspected, remove the transistor from the circuit and use an ohmmeter to measure internal resistance. See Table 5-4 for

**CAUTION**

Most ohmmeters can supply enough current or voltage to damage a transistor. Before using the ohmmeter, check ohmmeter open-circuit voltage and short-circuit current output ON THE RANGE TO BE USED. Open-circuit voltage must not exceed 1.5 volts and short-circuit current must be less than 3 mA. See Table 5-5 for safe resistance ranges for some common ohmmeters.

Table 5-4. Out-of-circuit Transistor Resistance Measurements.

TRANSISTOR TYPE	CONNECT OHMMETER POS LEAD TO	OHMMETER NES LEAD TO	MEASURE RESISTANCE (OHMS)
Ge PNP	SMALL SIGNAL	EMITTER EMITTER	200-500 10K-0100K
	POWER	EMITTER EMITTER	200-500 SEVERAL HUNDRED
Si NPN	SMALL SIGNAL	BASE COLLECTOR	1K-3K
		EMITTER EMITTER	VERY HIGH-MAY READ OPEN
	POWER	BASE COLLECTOR	200-1000
		EMITTER EMITTER	HIGH, OFTEN GREATER THAN IM
Si PNP	SMALL SIGNAL	EMITTER EMITTER	10K-100K
		EMITTER COLLECTOR	VERY HIGH- MAY READ OPEN

**\*TO TEST FOR TRANSISTOR ACTION, ADD COLLECTOR - BASE SHORT. MEASURED RESISTANCE SHOULD DECREASE.**

5-34. The Model 4800A uses plated through double sided etched circuit boards. To prevent damage to the circuit board and components, observe the following rules when soldering:

- a. Use a low heat (25 to 50 watts) soldering iron with a small tip (1/16" to 3/32" dia. ).
- b. To remove a component, clip a heat sink (long nose pliers, commercial heat sink tweezers etc. ) on the component lead as close to the component as possible. Place the soldering iron directly on the component lead and pull up on the lead. If a component is obviously damaged or faulty, clip the leads close to the component and then remove the leads from the board.

Table 5-5. Typical Ohmmeter Ranges and Currents

OHMMETER	SAFE RANGE(S)	OPEN CKT VOLTAGE	SHORT CKT CURRENT	LEAD	
				COLOR	POLARITY
hp 412A hp 427A	R x 1K	1.0V	1 mA	RED	+
	R x10K	1.0V	100 pA		
	R x 100K	1.0V	10 pU	BLACK	-
	R x 1M	1.0V	1pU		
	R x 10M	1.0V	0.1pU		
hp410C	R x 1K	1.3V	0.57 mA	RED	+
	R x 10K	1.3V	57pA		
	R x 100K	1.3V	5.7 pA	BLACK	-
	R x 1M	1.3V	0.5 pA		
	R X 10M	1.3V	0.05 pA		
hp410B	R x 100	1.1V	1.1Ma	RED	+
	R x 1K	1.1V	110 pA		
	R x 10K	1.1V	11 pA	BLACK	-
	R x 100K	1.1V	1.1 pA		
	R x 1M	1.1V	0.11 pA		
SIMPSON 260	R x 100	1.5V	1 MA	RED	+
				BLACK	-
SMPSON 269	R x 1K	1.5V	3.25 Ma	RED	+
				BLACK	-
TRIPLT 630	R x 100	1.5V	3.25 mA	VARIES WITH	
	R x 1K	1.5V	3.25pA	SERIAL NUMBER	
TRIPLT 310	R x 10	1.5V	750Pa		
	R x 100	1.5V	75pA		

**CAUTION**

EXCESSIVE OR PROLONGED HEAT

CAN LIFT THE CIRCUIT FOIL OR CAUSE DAMAGE TO COMPONENTS.

c. Clean the component lead holes by heating the solder in the hole, quickly removing the soldering iron, and inserting a pointed non-metallic object such as a toothpick.

d. To mount a new component, shape the leads and insert them in the holes. Clip a heat sink on the component, heat with the soldering iron, and add solder as necessary to obtain a good electrical **connection**.

e. Clip excess leads off after soldering and clean excess flux from the connections and adjoining area.

**5-35. REMOVAL OF ANALOG ASSEMBLY.** To remove the analog output assembly use the following procedure:

a. Remove four screws from rear panel.

b. Slide released BNC connector portion of analog circuit board through hole in rear panel and hold in position just above analog board card assembly.

c. Remove circuit board by pulling straight up on board assembly until it is released from connector slot and then sliding board straight up until it is free of guide tracks. Remove analog circuit board from impedance meter.

d. To install analog assembly, reverse removal procedure.

**5-36. FREQUENCY DIAL CORD REPLACEMENT.**

To replace the frequency dial cord, use the following procedure in conjunction with Figure 5-4.

**NOTE**

After the dial cord is replaced, it will be necessary to recalibrate the FRE-QUE NCY dial (refer to paragraph 5-17).

e. Connect one end of spring to dial cord and the other end of the spring to the rear pin of the analog pulley.

f. Place cord through rear slot and make one turn around analog pulley in a counterclockwise direction.

g. Pull cord downward small pulley and make 1-1/2 turns around small pulley in a counter clockwise direction.

h. Pull cord up towards analog pulley and place cord through front slot of analog pulley.

i. Secure dial cord to front pin of analog pulley.

j. Rotate FREQUENCY dial fully clockwise and connect DC voltmeter to FREQ connector on rear panel.

k. Loosen set screw on analog pulley and rotate R11 fully clockwise (looking from front panel).

l. Rotate R11 slightly counterclockwise and tighten set screws.

m. Rotate FREQUENCY dial to "5". The DC

voltmeter should read 0.1 V or less.

**5-38. CLEANING** - Should it become necessary to wash the 4800A the following procedure should be used.

a. Remove A22Q1

b. Remove meters from 4800A

c. Wash 4800A with warm water and mild detergent.

d. Remove excess water with dry nitrogen or air from a filtered high pressure line.

e. Bake in an oven at 650C for 24 hours.

f. A22Q1 should be washed in the same manner.

**CAUTION**

Use warm water and mild detergent only. The use of cleaning solvents may damage parts of the 4800A.

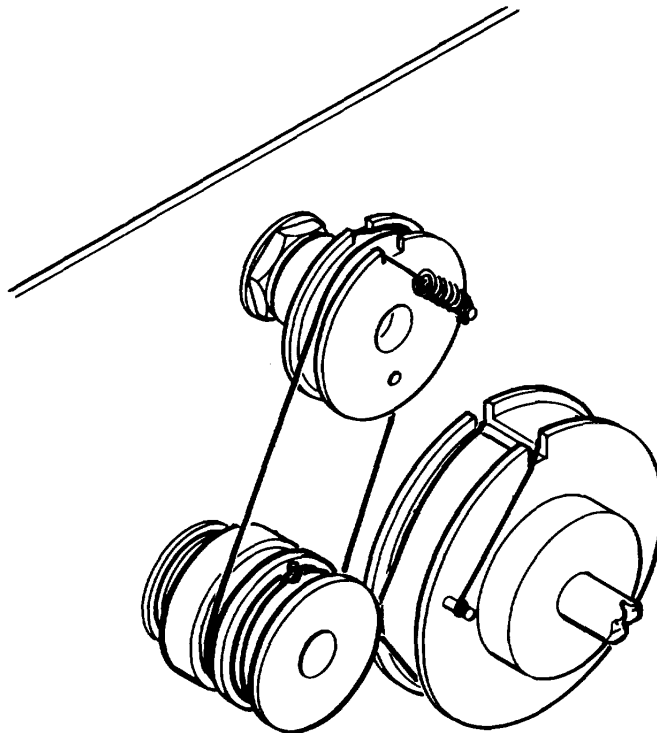

Figure 5-4. Dial Cord Replacement



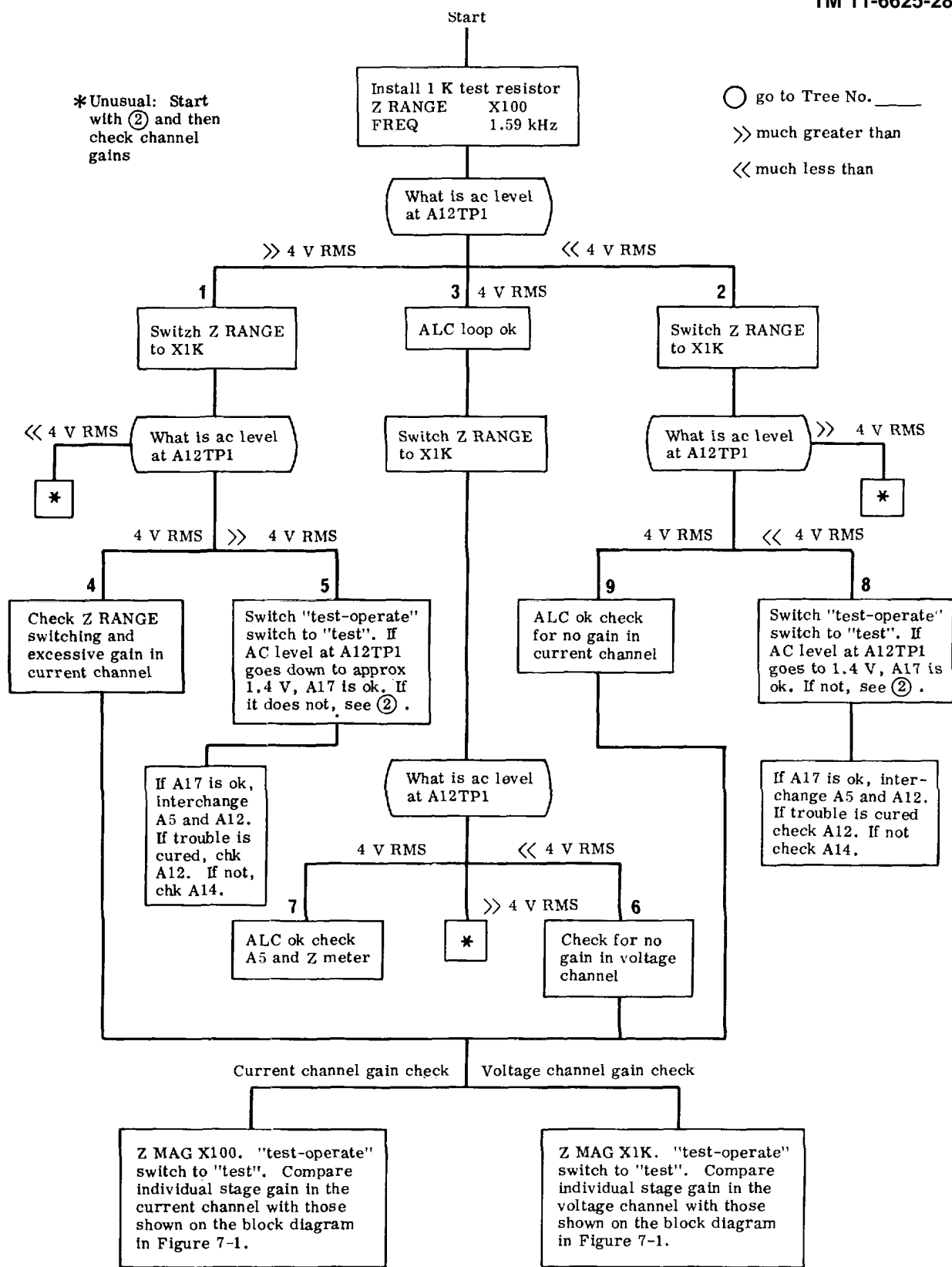

Figure 5-5. Troubleshooting Tree Number 1. (Sheet 1 of 2)

## COMMENTS

1. In the constant current mode the current channel drives A12 and is therefore part of the ALC loop. A large signal at A12TP1 means the test signal is too high and the loop is not bringing it down to normal. The next logical step is to try the constant voltage mode.
2. In the constant current mode the current channel drives A12 and is therefore part of the ALC loop. A small signal, or none at all, at A12TP1 indicates no test signal or serious loss of gain in the current channel. Switching to the constant voltage mode would be the next logical step.
3. A normal signal at this point means the test signal circuits (oscillator and AGC amp), current channel, and leveling loop are ok. The next step is to switch to the constant voltage mode.
4. At this point on the troubleshooting path the signal is normal. Therefore the voltage channel and leveling loop are ok. The constant current mode, which you just switched from, gave an incorrect reading at A12TP1. The trouble is then localized to the current channel. Consider A 12K1 as part of the current channel.
5. The signal at A12TP1 is high in constant current and constant voltage modes. Since it is assumed only one failure exists, the trouble is localized to A12, A14, A16, or A17. The "TEST-OPERATE" switch, S1, will be helpful here as it allows you to break the ALC loop. With the ALC loop open, the AGC amp has a gain of 1 and the AC level at A12TP1 should be approx 1.4 V.
6. In the constant voltage mode the voltage channel drives A12 and is therefore part of the ALC loop. A low signal means the test signal is too low and the loop is not bringing it up to normal. Since the constant current mode gave a correct reading, the trouble must be in the voltage channel.
7. In the constant voltage mode the voltage channel drives A12 and is therefore part of the ALC loop. Since you obtain the correct voltage at A12TP1 in both modes, the trouble must be in the meter or meter detector circuits.
8. The signal at A12TP1 is low in both constant current and constant voltage modes. Since it is assumed only one failure exists, the trouble is localized to A12, A14, A16, or A17. The "TEST-OPERATE" Switch, S1, will be helpful here as it allows you to break the ALC loop. With the ALC loop open, the AGC amp has a gain of 1 and the AC level at A12TP1 should be approx 1.4 V.
9. At this point in the troubleshooting path the signal is normal. Therefore the voltage channel and leveling loop are ok. Since the constant current mode produced an incorrect voltage at A12TP1, check the current channel for loss of gain.

*Figure 5-5. Troubleshooting Tree Number 1. (Sheet 2 of 2)*

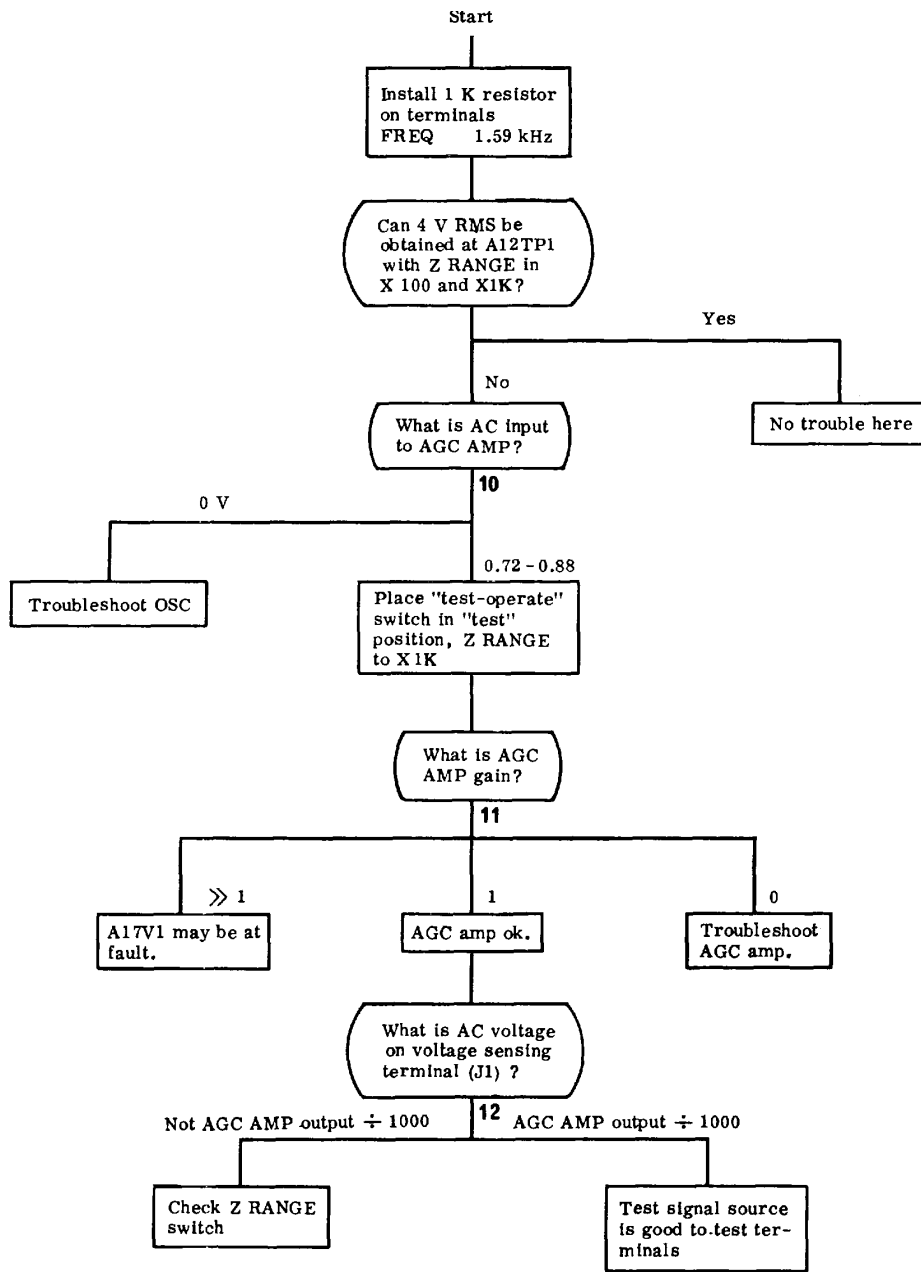

Figure 5-6. Troubleshooting Tree Number 2. (Sheet 1 of 2)

**COMMENTS**

10. At this point you must check for input to the AGC amp. It is normally  $0.8\text{ V} \pm 10\%$ . Don't forget the rear panel jumper may be missing.
11. The ALC feedback is now open. With the loop open, DS1 is off and V1 has a very high impedance, causing 100% feedback in the AGC amp. The AGC amp should now have a gain of 1.
12. There is a 1000:1 attenuation from the AGC amp output to J1 in this position of the magnitude range switch. If you have a usable signal, you can check gains through all the channel amplifiers. (The block diagram on Figure 7-1 will be a help for this.)

*Figure 5-6. Troubleshooting Tree Number 2. (Sheet 2 of 2)*

FREQUENCY SENSITIVE TROUBLES

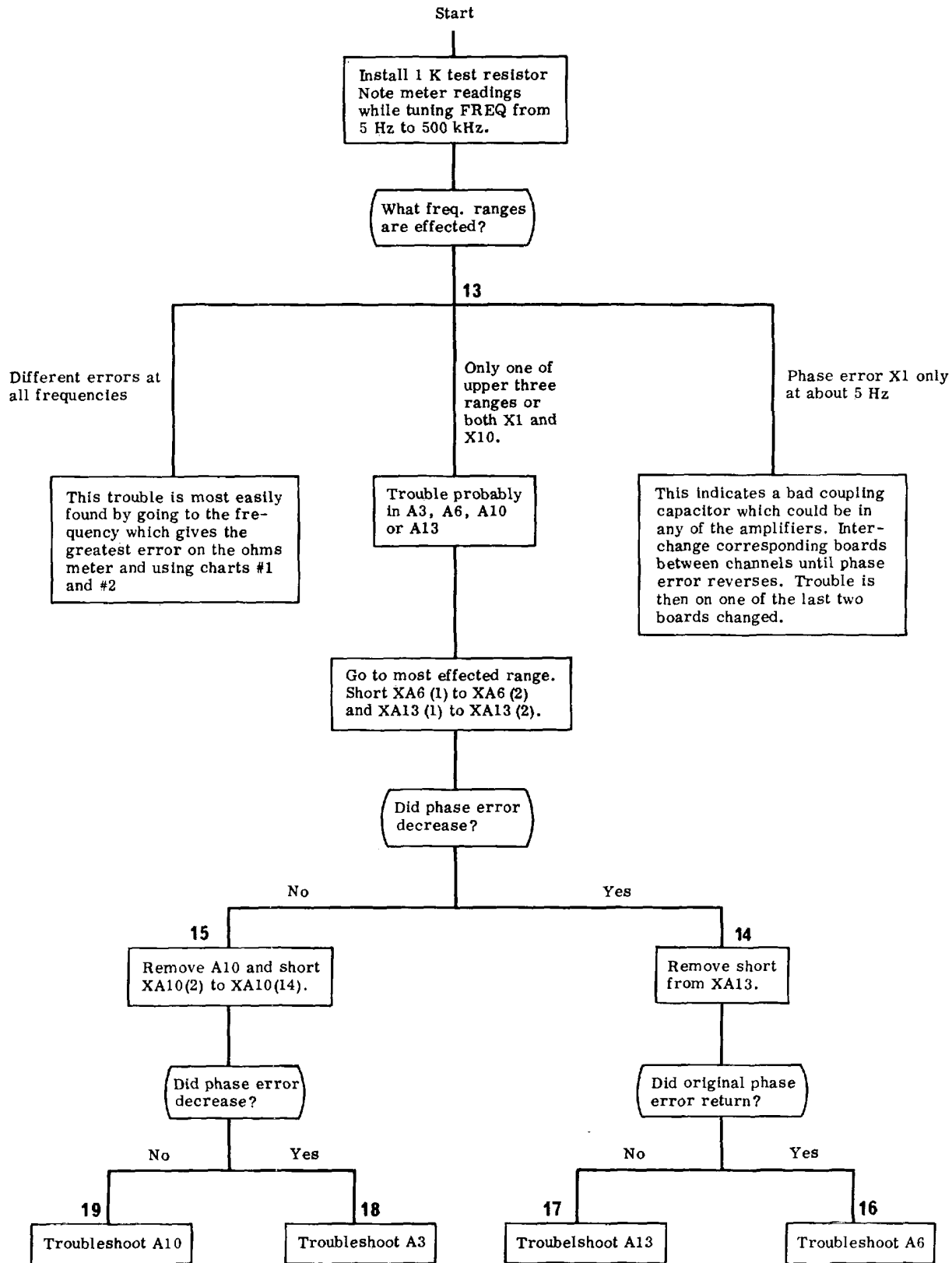

Figure 5-7. Troubleshooting Tree Number 3. (Sheet 1 of 2)

## COMMENTS

13. DO NOT USE THIS CHART if you have a significant magnitude failure. Troubles pertaining to this chart will be phase errors with small magnitude errors. Before making a decision be sure to check operation on all frequency ranges.
14. With both filter amplifiers shorted out the error decreased. This means one of the amplifiers is not introducing enough phase shift; thereby causing an incorrect phase relationship between the two channels.
15. With both filter amplifiers shorted there is no change. This means the problem is not in these filters, but probably in the band pass filters.
16. It has been determined the trouble is in either A13 or A6. By removing the short from A13 the original error returned. This means A13 is introducing a phase shift, which it should. The trouble must be in A6.
17. would normally cause a change in the phase reading because you are eliminating the phase shift through the A13 board. Since there was no change there must not be any phase shift through this circuit. This is abnormal and the A13 board should be checked.
18. Removing A10 and shorting input to output eliminates the phase shift that would normally occur in the A10 board. Since the error did not decrease there must not be any phase shift in the A3 board. This is abnormal; A3 should be checked.
19. This would normally cause a change in the phase reading because you are eliminating the phase shift through the A10 board. Since there was no change there must not be any phase shift through this circuit. This is abnormal and the A10 board should be checked.

*Figure 5-7. Troubleshooting Tree Number 3. (Sheet 2 of 2)*

PHASE TROUBLE ONLY

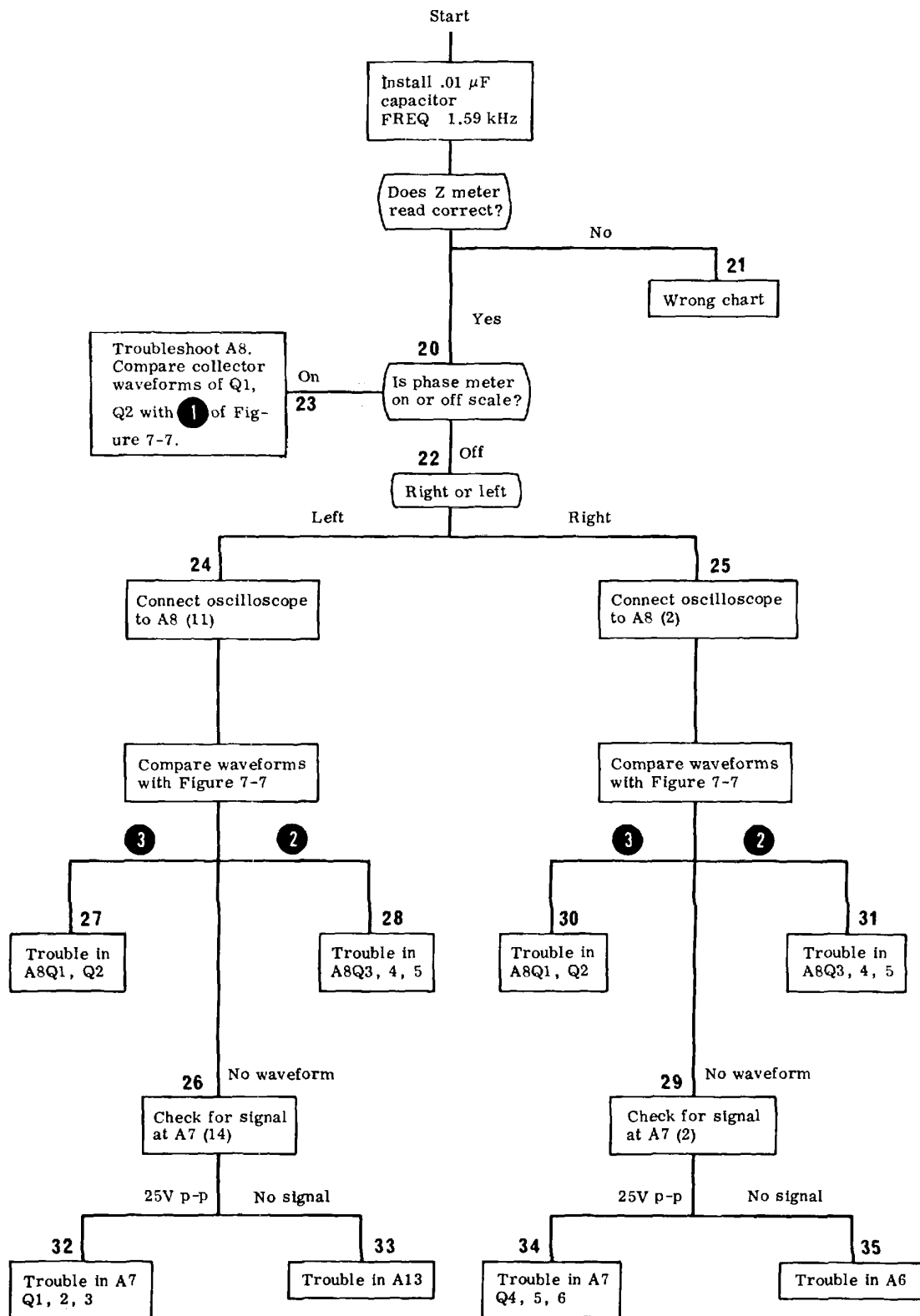

Figure 5-8. Troubleshooting Tree Number 4. (Sheet 1 of 2)

**COMMENTS**

20. With the Z MAGNITUDE meter reading correctly, you can assume the trouble lies in A6, A7, A8, or A13.
21. Remember this chart is for phase errors only. It is usually faster to troubleshoot magnitude errors if they exist. Use chart 1 and 3. Prerequisites for starting this tree are: near normal signals at the outputs of current and voltage channel amplifiers (A4 and A11, pin 14).
22. A pegged meter indicates the binary is locked in one state. The deflection of the meter indicates which state the binary is in and which channel is possibly defective.
23. An on scale reading but not  $-90^\circ$  means the binary is ok and being triggered. The next step would be to check the waveform at Q1 collector for proper amplitude. If it is correct, check A8Q4, 5. If it is not, check A8Q3.
24. A8Q1 is turned off. A waveform check at A8(11) will help localize the trouble.
25. A8SQ2 is turned off. A waveform check at A8(2) will help localize the trouble.
26. No waveform at A8(11) indicates no triggers from the voltage channel. Trouble is in A7 or A13.
27. Waveform 3 indicates the Schmitt Trigger is operating but the binary is not switching. Check A8Q1, Q2.
28. Waveform 2 indicates both Schmitt Triggers are operating and causing the binary to switch. Check A8Q3-5.
29. No waveform at A8(2) indicates no triggers from the current channel. Trouble is in A6 or A7.
30. Waveform 3 indicates the Schmitt Trigger is operating but the binary is not switching. Check A8Q1, Q2.
31. Waveform 2 indicates both Schmitt Triggers are operating and causing the binary to switch. Check A8Q3-5.
32. You find the proper input to the Schmitt Triggers (25 V p-p), therefore the trouble is in A7Q1-3.
33. No signal at this point means the trouble is in A13.
34. You find the proper input to the Schmitt Triggers (25 V p-p), therefore the trouble is in A7Q4-6.
35. No signal at this point means the trouble is in A6.

*Figure 5-8. Troubleshooting Tree Number 4. (Sheet 2 of 2)*



## SECTION VI. REPLACEABLE PARTS

### 6-1. INTRODUCTION

6-2. This section contains the information necessary to order replacement parts. Table 6-1 lists electrical parts for the 4800A in alpha-numerical order of reference designation. Table 6-2 is a similar list for the 4801A plug-in.

6-3. An exploded view of the instrument and plugin is given in Figure 6-1, showing location of mechanical parts and major electrical parts not located on printed circuit assemblies. The parts in Figure 6-1 are keyed to the legend in Table 6-3.

### 6-4. ORDERING INFORMATION

6-5. When ordering a replacement part listed in the tables:

a. Give the Hewlett-Packard Stock Number and the FSCM when ordering parts not in the Cross Reference Index (Section VIII).

b. Order the parts listed in Section VIII by the NSN's listed therein.

DESCRIPTION	HP PART NUMBER		
	STANDARD	OPTION A85	OPTION X95
Model 4800A			Refer to Manual Parts List
Cover, Top	5060-8589	5060-8589	
Cover, Bottom	5060-8713	5060-8713	
Cover, Side	5000-8705	5000-8705	
Cover, Side	5000-8707	5000-8707	
Retainer	5060-8737	5060-8737	
Rack Mount	5060-8740	5060-0775	
Front Panel	04800-01023	04800-01001	
Meter Extrusion	00741-01212	00741-01209	
Terminal Shield	00610-61002	00610-61001	
Model 4801A6-1			
Front Panel	04800-01024	04800-101011	

TABLE 6-1. REFERENCE DESIGNATION INDEX

REF.	STOCK NO.	DESCRIPTION
A1	04800-61001	UTILITY AMPLIFIER ASSEMBLY
	04800-22001	A1 Printed Circuit Board Blank
A1C1	0180-0155	C: fxd ta 2.2 pF 20% 20 vdcw
A1C2	0140-0202	C: fxd mica 15 pF 5% 500 vdcw
A1C3	0180-0137	C: fxd ta 100 pF 20% 10 vdcw
A1C4	0180-0155	C: fxd ta 2.2 pF 20% 20 vdcw
A1C5	0180-0137	C: fxd ta 100 pF 20% 10 vdcw
A1C6	0180-1702	C: fxd ta 180 pF 20% 6 vdcw
A1CR1-4	1901-0040	Diode S1
A1L1, 2	9100-1618	Coil-choke 5.6 pH 10%
A1Q1	1854-0215	Transistor- NPN S1 2N3904
A1Q2	1853-0036	Transistor- PNP S1 2N3906
A1Q3	1854-0215	Transistor-NPN S1 2N3904
A1Q4	1853-0036	Transistor- PNP S1 2N3906
A1R1	0757-0273	R: fxd met flm 3.01 KS2 1% 1/8 w
A1R2	0698-4123	R: fxd met flm 499 Q 1% 1/8 w
A1R3	0757-0288	R: fxd met flm 9.09 1K 1% 1/8 w
A1R4	0683-1015	R: fxd comp 100 n 5% 1/4 w
A1R5	0683-5605	R: fxd comp 56 Q 5% 1/4 w
A1R6	0683-5135	R: fxd comp 51 Kn 5% 1/4 w
A1R7	0757-0449	R: fxd met flm 20 Kn1 1% 1/8 w
A1R8	0757-0200	R: fxd, met flm, 5.62K 1%, 1/8W.
A1R9	0683-1015	R: fxd comp 100 Su 5% 1/4 w
A1R10	0683-5605	R: fxd comp 56 9 5% 1/4 w
A1R11	0698-4121	R: fxd met firm 11.3 KS 1% 1/8 w
A1R12	0757-0273	R: fxd met flm 3.01 Kg 1% 1/8 w
A1R13	0757-0408	R: fxd met flm 243 n 1% 1/8 w
A2	04800-61001	UTILITY AMPLIFIER Same as A1. Use A2 prefix.
A3	04800-61008	BANDPASS FILTER ASSEMBLY
	04800-22008	A3 Printed Circuit Board Blank
A3C1, 2	0160-0138	C: fxd my 0.047 iF 5% 200 vdcw
A3C3	0160-0938	C: fxd mica 0.001 AF 5% 100 vdcw
A3C4	0140-0195	C: fxd mica 130 pF 5% 300 vdcw
A3C5	0170-0019	C: fxd my 0.1 IF 5% 200 vdcw
A3C6	0160-0207	C: fxd my 0.01 F 5% 200 vdcw
A3C7	0160-0938	C: fxd mica 0.001 AF 5% 100 vdcw
A3C8-11	0160-0174	C: fxd cer 0.47 pF -20% + 80% 25 vdcw
A3C12	0180-0155	C: fxd ta 2.2 pF 20% 20 vdcw
A3CR1-10	1910-0016	Diode Ge
A3K1	0490-0399	Reed relay SPST
A3L1	9100-1618	Coil-choke 5.6 pH 10%
A3Q1	1854-0215	Transistor- NPN Si 2N3904
A3R1	0698-4435	R: fxd met flm 2.49 KΩ 1% 1/8 w
A3R2	0683-3915	R: fxd comp 390 Ω 5% 1/4 w
A3R3	0683-2045	R: fxd comp 200 KΩ 5% 1/4 w
A3R4	0683-1015	R: fxd comp 100 Ω 5% 1/4 w
A3R5	0683-5115	R: fxd comp 510 Ω 5% 1/4 w

TABLE 6-1. REFERENCE DESIGNATION INDEX (CONT)

REF.	STOCK NO.	DESCRIPTION
A3R6	0683-2035	R: fxd comp 20 K $\Omega$ 5% 1/4 w
A3R7	0683-1035	R: fxd comp 10 K $\Omega$ 5% 1/4 w
A3R8	0683-5135	R: fxd comp 51 K $\Omega$ 5% 1/4 w
A3R9	0698-4123	R: fxd met flm 499 $\Omega$ 1% 1/8 w
A3R10	0683-1035	R: fxd comp 10 K $\Omega$ 5% 1/4 w
A3R11	0698-4014	R: fxd met flm 787 $\Omega$ 1% 1/8 w
A3R12	0683-2045	R: fxd comp 200 K $\Omega$ 5% 1/4 w
A3R13	0683-2225	R: fxd comp 2.2 K $\Omega$ 5% 1/4 w
A3R14	0683-2035	R: fxd comp 20 K $\Omega$ 5% 1/4 w
A3R15	0683-2225	R: fxd comp 2.2 K $\Omega$ 5% 1/4 w
A3R16	0683-2045	R: fxd comp 200 K $\Omega$ 5% 1/4 w
A3R17	0683-1025	R: fxd comp 1 K $\Omega$ 5% 1/4 w
A3R18	0683-2035	R: fxd comp 20 K $\Omega$ 5% 1/4 w
A3R19	0683-1025	R: fxd comp 1 K $\Omega$ 5% 1/4 w
A3R20	0683-2045	R: fxd comp 200 K $\Omega$ 5% 1/4 w
A3R21	0683-1025	R: fxd comp 1 K $\Omega$ 5% 1/4 w
A3R22	0683-2035	R: fxd comp 20 K $\Omega$ 5% 1/4 w
A3R23	0683-1025	R: fxd comp 1 K $\Omega$ 5% 1/4 w
A3R24	0683-1035	R: fxd comp 10 K $\Omega$ 5% 1/4 w
A3R25	0683-2045	R: fxd comp 200 K $\Omega$ 5% 1/4 w
A4	04800-61001	UTILITY AMPLIFIER Same as A1. Use A4 prefix.
A5	04800-61009	DETECTOR ASSEMBLY NOTE: Replacement assemblies do not include R21 which must be selected.
	04800-22009	A5 Printed Circuit Board Blank
A5C1	0160-2150	C: fxd mica 33 pF 5% 300 vdcw
A5C2	0180-0155	C: fxd ta 2.2 pF 20% 20 vdcw
A5C3	0150-0093	C: fxd cer 0.01 pF -20% + 80% 100 vdcw
A5C4	0180-0155	C: fxd ta 2.2 pF 20% 20 vdcw
A5C5	0140-0202	C: fxd mica 15 pF 5% 500 vdcw
A5C6-8	0180-1702	C: fxd ta 180 pF 20% 6 vdcw
A5C9	0180-0155	C: fxd ta 2.2 pF 20% 20 vdcw
A5CR1-2	1910-0016	Diode Ge
A5CR3-5	1901-0040	Diode Si
A5CR6, 7	1910-0022	Diode Ge
A5E1	04800-81003	Transistors- 2N3904 matched pair
A5K1	0490-0393	Reed relay SPDT
A5L1, 2	9100-1618	Coil-choke 5.6 TH 10%
A5Q1, 2		Transistor Si 2N3904 NSR P/O A5E1
A5Q3	1853-0036	Transistor - PNP Si 2N3906
A5Q4	1854-0215	Transistor - NPN Si 2N3904
A5Q5	1853-0036	Transistor- PNP Si 2N3906
A5R1	0683-4715	R: fxd comp 470 0 5% 1/4 w
A5R2	0683-1035	R: fxd comp 10 K $\Omega$ 5% 1/4 w
A5R3	0698-4014	R: fxd met flm 787 $\Omega$ 1% 1/8 w
A5R4, 5	0757-0280	R: fxd met flm 1 K $\Omega$ 1% 1/8 w
A5R6	0683-2015	R: fxd comp 200 $\Omega$ 5% 1/4 w

TABLE 6-1. REFERENCE DESIGNATION INDEX (CONT)

REF.	STOCK NO.	DESCRIPTION
A5R7	0757-0435	R: fxd met flm 3.92 K $\Omega$ 1% 1/8 w
A5R8	0683-1015	R: fxd comp 100 $\Omega$ 5% 1/4 w
A5R9	0757-0273	R: fxd met flm 3.01 K $\Omega$ 1% 1/8 w
A5R10	0698-3497	R: fxd met flm 6.04 K $\Omega$ 1% 1/8 w
A5R11	0683-1535	R: fxd comp factory selected typical 15 K $\Omega$ 5% 1/4 w
A5R12	0683-1005	R: fxd comp 10 $\Omega$ 5% 1/4 w
A5R13	0683-1015	R: fxd comp 100 $\Omega$ 5% 1/4 w
A5R14	0757-0437	R: fxd met flm 4.75 K $\Omega$ 1% 1/8 w
A5R15	0683-1015	R: fxd comp 100 $\Omega$ 5% 1/4 w
A5R16, 17	0683-5605	R: fxd comp 56 $\Omega$ 5% 1/4 w
A5R18	0757-0446	R: fxd met flm 15 K $\Omega$ 1% 1/8 w
A5R19	0698-3225	R: fxd met flm 1.43 K $\Omega$ 1% 1/8 w
A5R20	0683-3355	R: fxd comp 3.3 M $\Omega$ 5% 1/4 w
A5R21	0683-1055	R: fxd comp factory selected typical 1 M $\Omega$ 5% 1/4 w
A5R22	0683-2255	R: fxd comp 2.2 M $\Omega$ 5% 1/4 w
A5R23	0683-1015	R: fxd comp 100 $\Omega$ 5% 1/4 w
A5R24	0757-0280	R: fxd met flm 1 K $\Omega$ 1% 1/8 w
A5R25	0683-1015	R: fxd comp 100 $\Omega$ 5% 1/4 w
A5TP1	0360-0479	Terminal - solder lug, P. C. mtg.
A6	04800-61010	FILTER AMP ASSEMBLY
	04800-22010	A6 Printed Circuit Board Blank
A6C1-3	0160-0174	C: fxd cer 0.47 pF -20% + 80% 25 vdcw
A6C4	0170-0019	C: fxd my 0.1 pF 5% 200 vdcw
A6C5	0160-0207	C: fxd my 0.01 pF 5% 200 vdcw
A6C6	0160-0938	C: fxd mica 0.001 pF 5% 100 vdcw
A6C7	0160-0335	C: fxd mica 91 pF 1% 300 vdcw
A6C8	0180-0137	C: fxd ta 100 pF 20% 10 vdcw
A6C9	0140-0202	C: fxd mica 15 pF 5% 500 vdcw
A6C10, 11	0180-1702	C: fxd ta 180 pF 20% 6 vdcw
A6C12, 13	0180-0155	C: fxd ta 2.2 pF 20% 20 vdcw
A6CR1-6	1910-0016	Diode Ge
A6CR7-10	1901-0040	Diode Si
A6L1, 2	9100-1618	Coil-choke 5.6 /H 10%
A6Q1	1854-0215	Transistor-NPN Si 2N3904
A6Q2	1853-0036	Transistor - PNP Si 2N3906
A6Q3	1854-0215	Transistor- NPN Si 2N3904
A6Q4	1853-0036	Transistor - PNP Si 2N3906
A6R1	0698-4014	R: fxd met flm 787 $\Omega$ 1% 1/8 w
A6R2	0683-2225	R: fxd comp 2.2 K $\Omega$ 5% 1/4 w
A6R3	0683-2035	R: fxd comp 20 K $\Omega$ 5% 1/4 w
A6R4	0683-2225	R: fxd comp 2.2 K $\Omega$ 5% 1/4 w
A6R5	0683-1055	R: fxd comp 1 M $\Omega$ 5% 1/4 w
A6R6	0683-2225	R: fxd comp 2.2 K $\Omega$ 5% 1/4 w
A6R7	0683-2035	R: fxd comp 20 K $\Omega$ 5% 1/4 w
A6R8	0683-2225	R: fxd comp 2.2 K $\Omega$ 5% 1/4 w
A6R9	0683-1055	R: fxd comp 1 M $\Omega$ 5% 1/4 w
A6R10	0683-2225	R: fxd comp 2.2 K $\Omega$ 5% 1/4 w
A6R11	0683-2035	R: fxd comp 20 K $\Omega$ 5% 1/4 w
A6R12	0683-2225	R: fxd comp 2.2 K $\Omega$ 5% 1/4 w
A6R13	0683-1055	R: fxd comp 1 M $\Omega$ 5% 1/4 w
A6R14	0683-5135	R: fxd comp 51 K $\Omega$ 5% 1/4 w

TABLE 6-1. REFERENCE DESIGNATION INDEX (CONT)

REF.	STOCK NO.	DESCRIPTION
A6R15	0757-0273	R: fxd met flm 3.01 K $\Omega$ 1% 1/8 w
A6R16	0698-4123	R: fxd met flm 499 $\Omega$ 1% 1/8 w
A6R17	0757-0288	R: fxd met flm 9.09 K $\Omega$ 1% 1/8 w
A6R18	0683-1015	R: fxd comp 100 $\Omega$ 5% 1/4 w
A6R19	0757-0449	R: fxd met flm 20 K $\Omega$ 1% 1/8 w
A6R20	0757-0200	R: fxd met flm 5.62 K $\Omega$ 1% 1/8 w
A6R21	0683-1015	R: fxd comp 100 $\Omega$ 5% 1/4 w
A6R22, 23	0683-5605	R: fxd comp 56 $\Omega$ 5% 1/4 w
A6R24	0698-4121	R: fxd met flm 11.3 K $\Omega$ 1% 1/8 w
A6R25	0757-0273	R: fxd met flm 3.01 K $\Omega$ 1% 1/8 w
A6R26	0757-0419	R: fxd met flm 681 $\Omega$ 1% 1/8 w
A7	04800-61013	SCHMITT TRIGGER
	04800-22013	A7 Printed Circuit Board Blank
A7C1	0180-0155	C: fxd ta 2.2 pF 20% 20 vdcw
A7C2	0140-0204	C: fxd mica 47 pF 5% 500 vdcw
A7C3	0140-0192	C: fxd mica 68 pF 5% 300 vdcw
A7C4, 5	0180-0155	C: fxd ta 2.2 pF 20% 20 vdcw
A7C6	0140-0204	C: fxd mica 47 pF 5% 500 vdcw
A7C7	0140-0192	C: fxd mica 68 pF 5% 300 vdcw
A7C8	0180-0155	C: fxd ta 2.2 pF 20% 20 vdcw
A7CR1-6	1901-0040	Diode Si
A7 L1	9100-1618	Coil-choke 5.6 pH 10%
A7L2	9140-0107	Coil fxd RF 27 pH
A7L3, 4	9100-1618	Coil-choke 5.6 pH 10%
A7L5	9140-0107	Coil fxd RF 27 pH
A7L6	9100-1618	Coil-choke 5.6 tpH 10%
A7Q1-6	1854-0215	Transistor- NPN Si 2N3904
A7R1	0757-0401	R: fxd met flm 100 $\Omega$ 1% 1/8 w
A7R2	0757-0411	R: fxd met flm 332 $\Omega$ 1% 1/8 w
A7R3	0757-0427	R: fxd met flm 1.5 K $\Omega$ 1% 1/8 w
A7R4	0757-0879	R: fxd met flm 2.49 K $\Omega$ 1% 1/4 w
A7R5	0757-0437	R: fxd met flm 4.75 K $\Omega$ 1% 1/8 w
A7R6	0757-0436	R: fxd met flm 4.32 K $\Omega$ 1% 1/8 w
A7R7	2100.-3(%)	R: var ww 10-turn 1 K $\Omega$ 5% 3/4 w
A7R8	0757-0273	R: fxd met flm 3.01 K $\Omega$ 1% 1/8 w
A7R9	0757-0437	R: fxd met flm 4.75 K $\Omega$ 1% 1/8 w
A7R10	0757-0401	R: fxd met firm 100 $\Omega$ 1% 1/8 w
A7R11	0757-0411	R: fxd met flm 332 $\Omega$ 1% 1/8 w
A7R12	0752-0427	R: fxd met flm 1.5 K $\Omega$ 1% 1/8 w
A7R13	0757-0879	R: fxd met flm 2.49 K $\Omega$ 1% 1/4 w
A7R14	0757-0437	R: fxd met flm 4.75 K $\Omega$ 1% 1/8 w
A7R15	0757-0436	R: fxd met flm 4.32 K $\Omega$ 1% 1/8 w
A7R16	2100-1642	R: var ww 10-turn 1 K $\Omega$ 5% 3/4 w
A7R17	0757-0273	R: fxd met flm 3.01 K $\Omega$ 1% 1/8 w
A7R18	0757-0437	R: fxd met flm 4.75 K $\Omega$ 1% 1/8 w
A8	04800-61014	PHASE DETECTOR
	04800-22014	A8 Printed Circuit Board Blank
A8C1	0180-0155	C: fxd ta 2.2 pF 20% 20 vdcw
A8C2	0160-0174	C: fxd cer 0.47 pF-20 + 80% 25 vdcw
A8C3	0180-0139	C: fxd alum 200 pF-10% + 100% 3 vdcw NP

TABLE 6-1. REFERENCE DESIGNATION INDEX (CONT)

REF.	STOCK NO.	DESCRIPTION
A8C4	0180-0155	C: fxd ta 2.2 #F 20% 20 vdcw
A8CR1-8	1901-0040	Diode Si
A8L1, 2	9100-1618	Coil-choke 5.6 pH 10%
A8Q1, 2	1853-0009	Transistor - PNP Si
A8Q3-5	1854-0215	Transistor - NPN Si 2N3904
A8R1, 2	0683-8235	R: fxd comp 82 K $\Omega$ 5% 1/4 w
A8R3, 4	0698-3497	R: fxd met flm 6.04 K $\Omega$ 1% 1/8 w
A8R5	0698-4444	R: fxd met flm 4.87 K $\Omega$ 1% 1/8 w
A8R6	0698-3497	R: fxd met flm 6.04 K $\Omega$ 1% 1/8 w
A8R7	0698-0064	R: fxd met flm 9.31 K $\Omega$ 1% 1/8 w
A8R8	0757-0442	R: fxd met flm 10 K $\Omega$ 1% 1/8 w
A8R9	0757-0431	R: fxd met flm 2.43 K $\Omega$ 1% 1/8 w
A8R10, 11	0757-1099	R: fxd met flm 900 $\Omega$ 1% 1/8 w
A8R12	0698-3558	R: fxd met flm 4.02 K $\Omega$ 1% 1/8 w
A8R13	0757-0431	R: fxd met flm 2.43 K $\Omega$ 1% 1/8 w
ASR14	0698-3558	R: fxd met flm 4.02 M $\Omega$ 1% 1/8 w
A8R15	0757-0827	R: fxd met flm 2.74 K $\Omega$ 1% 1/2 w
A8R16	2100-1757	R: var ww 500 $\Omega$ 10% 1/2 w
A8R17	0698-0086	R: fxd met firm 2.87 K $\Omega$ 1% 1/4 w
A8R18	0757-0827	R: fxd met flm 2.74 K $\Omega$ 1% 1/2 w
ASR19	2100-1758	R: var ww 1 K $\Omega$ 10% 1/2 w
A8R20	0757-0280	R: fxd met flm 1 K $\Omega$ 1% 1/8 w
A9	04800-61001	UTILITY AMPLIFIER Same as A1. Use A9 prefix.
A10	04800-61008	BANDPASS FILTER Same as A3. Use A10 prefix.
A11	04800-61001	UTILITY AMPLIFIER Same as A1. Use All prefix.
A12	04800-61009	DETECTOR ASSEMBLY Same as A5. Use A12 prefix. NOTE: Replacement assemblies do not include R21. Add resistor listed below before installing assembly.
A12R21	0683-1055	R: fxd comp 1 M $\Omega$ 5% 1/4 w
A13	04800-61010	FILTER AMP ASSEMBLY Same as A6. Use A13 prefix.
A14	04800-61016	DC AMPLIFIER
	04800-22016	A14 Printed Circuit Board Blank
A14C1		Not assigned
A14C2, 3	0180-0155	C: fxd ta 2.2 pF 20% 20 vdcw
A14C4	0180-0374	C: fxd ta 10 pF 10% 20 vdcw
A14CR1-4		Not assigned
A14CR5, 6	1901-0040	Diode Si
A14E1	04800-81004	Transistors - 2N3906 matched pair
A14E2	04800-81003	Transistors- 2N3904 matched pair
A14L1, 2	9100-1618	Coil-choke 5.6 pH 10%
A14Q1, 2		Transistor-PNP Si 2N3906 NSR P/O A14E1
A14Q3,	41853-0036	Transistor- PNP Si 2N3906
A14Q5, 6		Transistor-NPN Si 2N3904 NSR P/O A14E2
A14Q7	1854-0071	Transistor - NPN Si similar to 2N3391

TABLE 6-1. REFERENCE DESIGNATION INDEX (CONT)

REF.	STOCK NO.	DESCRIPTION
A14Q8	1854-0215	Transistor - NPN Si 2N3904
A14Q9	1854-0039	Transistor - NPN Si 2N3053
	1205-0033	Heat dissipater (use with A14Q9)
A14Q10	1853-0036	Transistor - PNP Si 2N3906
A14R1	0683-1015	R: fxd comp 100 $\Omega$ 5% 1/4 w
A14R2	0757-0280	R: fxd met flm 1.0 K $\Omega$ 1% 1/8 w
A14R3	0683-1015	R: fxd comp 100 n 5% 1/4 w
A14R4-7		Not assigned
A14R9	0757-0288	R: fxd met flm 9.09K, 1%, 1/8W.
A14R10-12		Not assigned
A14R13	0683-1015	R: fxd comp 100 $\Omega$ 5% 1/4 w
A14R14	0757-0465	R: fxd met flm 100 K $\Omega$ 1% 1/8 w
A14R15, 16	0757-0437	R: fxd met flm 4.75 K $\Omega$ 1% 1/8 w
A14R17	0757-0465	R: fxd met flm 100 K $\Omega$ 1% 1/8 w
A14R18	2100-1755	R: var ww 100 $\Omega$ 10% 1 w
A14R19, 20	0757-0427	R: fxd met flm 1.5 K $\Omega$ 1% 1/8 w
A14R21		Not assigned
A14R22	0757-0274	R: fxd met flm 1.21 K $\Omega$ 1% 1/4 w
A14R23	0683-1015	R: fxd comp 100 $\Omega$ 5% 1/4 w
A14R24	0698-4406	R: fxd met flm 115 $\Omega$ 1% 1/8 w
A14R25	2100-1654	R: var ww 20-turn 100 $\Omega$ 10% 1/2 w
A14R26	0757-0738	R: fxd met flm 1.82 K $\Omega$ 1% 1/4 w
A14R27	0698-3497	R: fxd met flm 6.04 K $\Omega$ 1% 1/8 w
A14R28	0683-1015	R: fxd comp 100 $\Omega$ 5% 1/4 w
A14R29	0698-3403	R: fxd met flm 348 $\Omega$ 1% 1/2 w
A14R30	0698-3497	R: fxd met flm 6.04 K $\Omega$ 1% 1/8 w
A14R31	0757-0439	R: fxd met flm 6.81 K $\Omega$ 1% 1/8 w
A14R32, 33	0757-0427	R: fxd met flm 1.5 K $\Omega$ 1% 1/8 w
A14R34	0757-0273	R: fxd met flm 3.01 K $\Omega$ 1% 1/8 w
A14R35	0698-3153	R: fxd met flm 3.83 K $\Omega$ 1% 1/8 w
A14R36	0757-0442	R: fxd met flm 10 K $\Omega$ 1% 1/8 w
A14R37	0757-0447	R: fxd met flm 16.2 K $\Omega$ 1% 1/8 w
A14R38	0757-0288	R: fxd met flm 9.09 K $\Omega$ 1% 1/8 w
A14TP1-4	0360-0479	Terminal- solder lug, P.C. mtg.
A15	04800-61012	ANALOG BOARD ASSEMBLY
	04800-22012	A15 Printed Circuit Board Blank
A15CR1-6	1901-0040	Diode Si
A15Q1	1854-0215	Transistor- NPN Si 2N3904
A15Q2, 3	1853-0036	Transistor - PNP Si 2N3906
A15Q4	1854-0215	Transistor-NPN Si 2N3904
A15Q5	1853-0036	Transistor - PNP Si 2N3906
A15Q6, 7	1854-0215	Transistor- NPN Si 2N3904
A15Q8, 9	1853-0036	Transistor - PNP Si 2N3906
A15Q10, 11	1854-0215	Transistor - NPN Si 2N3904
A15Q12	1853-0036	Transistor- PNP Si 2N3906
A15R1, 2	0683-1015	R: fxd comp 100 $\Omega$ 5% 1/4 w
A15R3	0757-0273	R: fxd met flm 3.01 K $\Omega$ 1% 1/8 w
A15R4-6	0757-0280	R: fxd met flm 1 K $\Omega$ 1% 1/8 w
A15R7	0757-0427	R: fxd met flm 1.5 K $\Omega$ 1% 1/8 w
A15R8	0757-0273	R: fxd met flm 3.01 K $\Omega$ 1% 1/8 w

TABLE 6-1. REFERENCE DESIGNATION INDEX (CONT)

REF.	STOCK NO.	DESCRIPTION
A15R9	0757-0434	R: fxd met flm 3.65 K $\Omega$ 1% 1/8 w
A15R10	0757-0273	R: fxd met flm 3.01 K $\Omega$ 1% 1/8 w
A15R11	0683-1015	R: fxd comp 100 $\Omega$ 5% 1/4 w
A15R12	0757-0273	R: fxd met flm 3.01 K $\Omega$ 1% 1/8 w
A15R13	0757-0439	R: fxd met flm 6.81 K $\Omega$ 1% 1/8 w
A15R14	0757-0280	R: fxd met flm 1 K $\Omega$ 1% 1/8 w
A15R15, 16	0683-1015	R: fxd comp 100 $\Omega$ 5% 1/4 w
A15R17	0757-0273	R: fxd met flm 3.01 K $\Omega$ 1% 1/8 w
A15R18-20	0757-0280	R: fxd met flm 1 K $\Omega$ 1% 1/8 w
A15R21	0757-0427	R: fxd met flm 1.5 K $\Omega$ 1% 1/8 w
A15R22	0757-0273	R: fxd met flm 3.01 K $\Omega$ 1% 1/8 w
A15R23	0757-0434	R: fxd met flm 3.65 K $\Omega$ 1% 1/8 w
A15R24	0757-0273	R: fxd met flm 3.01 K $\Omega$ 1% 1/8 w
A15R25	0683-1015	R: fxd comp 100 $\Omega$ 5% 1/4 w
A15R26	0757-0273	R: fxd met flm 3.01 K $\Omega$ 1% 1/8 w
A15R27	0757-0439	R: fxd met flm 6.81 K $\Omega$ 1% 1/8 w
A15R28	0757-0280	R: fxd met flm 1 K $\Omega$ 1% 1/8 w
A15R29	0698-4484	R: fxd met flm 19.1 K $\Omega$ 1% 1/8 w
A16	04800-61003	OSCILLATOR ASSEMBLY
	04800-22003	A16 Printed Circuit Board Blank
A16C1	0121-0105	C: var cer 9-35 pF
A16C2	0160-2198	C: fxd mica 20 pF 5% 300 vdcw
A16C3	0180-0228	C: fxd ta 22 pF 10% 15 vdcw
A16C4	0150-0093	C: fxd cer 0.01 pF -20% + 80% 100 vdcw
A16C5, 6	0180-1765	C: fxd ta 560 pF 10% 6 vdcw
A16C7	0180-0141	C: fxd alum 50 AF -10% + 75% 50 vdcw
A16C8	0160-0157	C: fxd my 0.0047 pF 10%
A16C9	0180-0141	C: fxd alum 50 pF -10% + 75% 50 vdcw
A16C10	0160-0157	C: fxd my 0.0047 pF 10%
A16CR1-9	1901-0040	Diode Si
A16CR10	1902-0049	Diode Si brkdwn 6.19 V 5% 400 mW
A16E1	5080-1718	Lamp assembly
A16Q1	1854-0215	Transistor - NPN Si 2N3904
A16Q2	1853-0036	Transistor- PNP Si 2N3906
A16Q3	1854-0215	Transistor - NPN Si 2N3904
A16Q4	1853-0036	Transistor - PNP Si 2N3906
A16Q5, 6	1854-0215	Transistor - NPN Si 2N3904
A16Q7, 8	1853-0036	Transistor PNP Si 2N3906
A16R1	0757-0273	R: fxd met flm 3.01 K $\Omega$ 1% 1/8 w
A16R2	0683-1015	R: fxd comp 100 $\Omega$ 5% 1/4 w
A16R3	0757-0273	R: fxd met flm 3.01 K $\Omega$ 1% 1/8 w
A16R4	0698-4123	R: fxd met flm 499 $\Omega$ 1% 1/8 w
A16R5	0757-0446	R: fxd met flm 15 K $\Omega$ 1% 1/8 w
A16R6	0757-0449	R: fxd met flm 20 K $\Omega$ 1% 1/8 w
A16R7	0757-0288	R: fxd met flm 9.09 K $\Omega$ 1% 1/8 w
A16R8	0757-0449	R: fxd met flm 20 K $\Omega$ 1% 1/8 w
A16R9	0757-0200	R: fxd met flm 5.62 K $\Omega$ 1% 1/8 w
A16R10, 11	0683-1015	R: fxd comp 100 $\Omega$ 5% 1/4 w
A16R12, 13	0683-5605	R: fxd comp 56 $\Omega$ 5% 1/4 w
A16R14	0757-0446	R: fxd met flm 15 K $\Omega$ 1% 1/8 w
A16R15	0757-0269	R: fxd met flm 270 $\Omega$ 1% 1/8 w



TABLE 6-1. REFERENCE DESIGNATION INDEX (CONT)

REF.	STOCK NO.	DESCRIPTION
A16R16 A16R17, 18		R: special pos temp coeff approx 100 $\Omega$ NSR P/O A16E1 Lamp INCD GE 5181D 10 V 15 mA. Cold res approx 60 $\Omega$ NSR P/O A16E1
A16R19	0698-4123	R: fxd met flm 499 $\Omega$ 1% 1/8 w
A16R20	2100-1963	R: var flm 2 K $\Omega$
A16R21	0757-0280	R: fxd met flm 1 K $\Omega$ 1% 1/8 w
A16R22	0698-3498	R: fxd met flm 8.66 K $\Omega$ 1% 1/8 w
A16R23	0683-1015	R: fxd comp 100 0 5% 1/4 w
A16R24	0757-0280	R: fxd met flm 1 K $\Omega$ 1% 1/8 w
A16R25	0757-0288	R: fxd met flm 9.09 K $\Omega$ 1% 1/8 w
A16R26	0698-3497	R: fxd met flm 6.04 K $\Omega$ 1% 1/8 w
A16R27	0698-3493	R: fxd met flm 4.12 K $\Omega$ 1% 1/8 w
A16R28	0683-1015	R: fxd comp 100 $\Omega$ 5% 1/4 w
A16R29	0757-0280	R: fxd met flm 1 K $\Omega$ 1% 1/8 w
A16R30	0757-0273	R: fxd met flm 3.01 K $\Omega$ 1% 1/8 w
A17	04800-61002 04800-22002	AGC AND MONITOR AMPLIFIER ASSEMBLY A17 Printed Circuit Board Blank
A17C1	0180-0155	C: fxd ta 2.2 pF 20% 20 vdcw
A17C2	0140-0202	C: fxd mica 15 pF 5% 500 vdcw
A17C3	0180-0137	C: fxd ta 100 pF 20% 10 vdcw
A17C4	0180-0155	C: fxd ta 2.2 pF 20% 20 vdcw
A17C5	0180-1702	C: fxd ta 180 pF 20% 6 vdcw
A17C6-8	0180-0137	C: fxd ta 100 pF 20% 10 vdcw
A17CR1-8	1901-0040	Diode Si
A17DS1		Lamp INCD 6 V NSR P/O A17E1
A17E1	1990-0079	Photocell lamp module includes A17V1 and A17DS1
A17L1, 2	9100-1618	Coil-choke 5.6 pH 10%
A17Q1		1854-0215..... Transistor NPN Si 2N3904
A17Q2		1853-0036..... Transistor PNP Si 2N3906
A17Q3		1854-0215..... Transistor NPN Si 2N3904
A17Q4		1853-0036..... Transistor PNP Si 2N3906
A17Q5		1854-0215..... Transistor NPN Si 2N3904
A17Q6		1853-0036..... Transistor PNP Si 2N3906
A17R1	0757-0273	R: fxd met flm 3.01 K $\Omega$ 1% 1/8 w
A17R2	0698-4123	R: fxd met flm 499 $\Omega$ 1% 1/8 w
A17R3	0757-0288	R: fxd met flm 9.09 K $\Omega$ 1% 1/8 w
A17R4	0683-1015	R: fxd comp 100 $\Omega$ 5% 1/4 w
A17R5	0683-5605	R: fxd comp 56 $\Omega$ 5% 1/4 w
A17R6	0683-5135	R: fxd comp 51 K $\Omega$ 5% 1/4 w
A17R7	0757-0449	R: fxd met flm 20 K $\Omega$ 1% 1/8 w
A17R8	0757-0200	R: fxd met flm 5.62 K $\Omega$ 1% 1/8 w
A17R9	0683-1015	R: fxd comp 100 $\Omega$ 5% 1/4 w
A17R10	0683-5605	R: fxd comp 56 $\Omega$ 5% 1/4 w
A17R11	0698-4121	R: fxd met flm 11.3 K $\Omega$ 1% 1/8 w
A17R12	0683-1025	R: fxd comp 1 K $\Omega$ 5% 1/4 w
A17R13-15		Not assigned
A17R16	0757-0440	R: fxd met flm 7.5 K $\Omega$ 1% 1/8 w
A17R17	0698-4435	R: fxd met flm 2.49 K $\Omega$ 1% 1/8 w
A17R18, 19	0683-1035	R: fxd comp 10 K $\Omega$ 5% 1/4 w
A17R20, 21	0683-5605	R: fxd comp 56 $\Omega$ 5% 1/4 w

TABLE 6-1. REFERENCE DESIGNATION INDEX (CONT)

REF.	STOCK NO.	DESCRIPTION
A17R22	0683-1035	R: fxd comp 10 KΩ 5% 1/4 w
A17R23	0757-0416	R: fxd met flm 511 Ω 1% 1/8 w
A17V1		Photocell special NSR P/O A17E1
A18	04800-61004	20 V REGULATOR ASSEMBLY
	04800-22004	A18 Printed Circuit Board Blank
A18C1	0160-0818	C: fxd cer 0.02 AF 20% 50 vdcw
A18C2	0140-0234	C: fxd mica 500 pF 1% 300 vdcw
A18C3	0180-0141	C: fxd alum 50 pF -10% + 75% 50 vdcw
A18C4	0180-0158	C: fxd alum 500 pF -10% + 75% 25 vdcw
A18C5	0160-0818	C: fxd cer 0.02 pF 20% 50 vdcw
A18C6	0140-0234	C: fxd mica 500 pF 1% 300 vdcw
A18C7	0180-0158	C: fxd alum 500 pF -10% + 75% 25 vdcw
A18CR1	1902-0049	Diode Si brkdwn 6.19 V 5% 400 mW
A18CR2	1902-0018	Diode Si brkdwn 11.7 V 5% 250 mW
A18CR3	1902-3181	Diode Si brkdwn 12.1 V 10% 400 mW
A18CR4	1902-0071	Diode Si brkdwn 9 V 5% temp comp
A18CR5	1902-0049	Diode Si brkdwn 6.19 V 5% 400 mW
A18CR6	1901-0040	Diode Si
A18CR7	1902-0018	Diode Si brkdwn 11.7 V 5% 250 mW
A18CR8	1902-3181	Diode Si brkdwn 12.1 V 10% 400 mW
A18E1	04800-81001	Transistors - 2N3904 matched pair
A18E2	04800-81002	Transistors- 2N3906 matched pair
A18Q1		1853-0036..... Transistor PNP Si 2N3906
A18Q2-4	1854-0215	Transistor NPN Si 2N3904
A18Q5, 6		Transistor NPN Si 2N3904 NSR P/O A18E1
A18Q7		1854-0215..... Transistor NPN Si 2N3904
A18Q8-10	1853-0036	Transistor PNP Si 2N3906
A18Q11, 12		Transistor PNP Si 2N3906 NSR P/O A18E2
A18R1	0683-1525	R: fxd comp 1.5 KΩ 5% 1/4 w
A18R2	0683-3935	R: fxd comp 39 KΩ 5% 1/4 w
A18R3	0683-1235	R: fxd comp 12 KΩ 5% 1/4 w
A18R4	0683-1015	R: fxd comp 100 Ω 5% 1/4 w
A18R5	0689-1525	R: fxd comp 1.5 KΩ 5% 1/4 w
A18R6	0683-1125	R: fxd comp 1.1 KΩ 5% 1/4 w
A18R7	0683-1035	R: fxd comp 10 KΩ 5% 1/4 w
A18R8	0812-0077	R: fxd ww 3 Ω 5% 2 w
A18R9	0683-2035	R: fxd Comp 20 KΩ 5% 1/4 w
A18R10	0683-3315	R: fxd comp 330 Ω 5% 1/4 w
A18R11	0683-2025	R: fxd comp 2 KΩ 5% 1/4 w
A18R12	0683-2035	R: fxd comp 20 KΩ 5% 1/4 w
A18R13, 14	0683-5105	R: fxd comp 51 Ω 5% 1/4 w
A18R15	0683-1035	R: fxd comp 10 KΩ 5% 1/4 w
A18R16	2100-3152'	R: var ww lin 5 KΩ 10% 1 w
A18R17	0683-1025	R: fxd comp 1 KΩ 5% 1/4 w
A18R18	0683-1525	R: fxd comp 1.5 KΩ 5% 1/4 w
A18R19	0683-3935	R: fxd comp 39 KΩ 5% 1/4 w
A18R20	0683-2035	R: fxd comp 20 KΩ 5% 1/4 w
A18R21	0683-1015	R: fxd comp 100 Ω 5% 1/4 w

TABLE 6-1. REFERENCE DESIGNATION INDEX (CONT)

REF.	STOCK NO.	DESCRIPTION
A18R22	0689-1525	R: fxd comp 1.5 K $\Omega$ 5% 1/4 w
A18R23	0683-1125	R: fxd comp 1.1 K $\Omega$ 5% 1/4 w
A18R24	0683-1035	R: fxd comp 10 K $\Omega$ 5% 1/4 w
A18R25	0812-0077	R: fxd ww 3 $\Omega$ 5% 2 w
A18R26	0683-2035	R: fxd comp 20 K $\Omega$ 5% 1/4 w
A18R27	0683-3315	R: fxd comp 330 $\Omega$ 5% 1/4 w
A18R28	0683-2025	R: fxd comp 2 K $\Omega$ 5% 1/4 w
A18R29	0683-2035-	R: fxd comp 20 K $\Omega$ 5% 1/4 w
A18R30, 31	0683-5105	R: fxd comp 51 $\Omega$ 5% 1/4 w
A18R32	0683-1035	R: fxd comp 10 K $\Omega$ 5% 1/4 w
A18R33, 34	0698-3327	R: fxd met flm 3.92 K $\Omega$ 0.5% 1/8 w
A19	04800-61005	RECTIFIER AND 14 V REGULATORS
	04800-22005	A19 Printed Circuit Board Blank
A19C1	0160-0174	C: fxd cer 0.47 AF -20% + 80% 25 vdcw
A19C2	0140-0178	C: fxd mica 560 pF 2%
A19C3	0160-0818	C: fxd cer 0.02 pF 20% 50 vdcw
A19C4	0160-0174	C: fxd cer 0.47 pF -20% + 80% 25 vdcw
A19C5	0140-0178	C: fxd mica 560 pF 2%
A19C6	0160-0818	C: fxd cer 0.02 pF 20% 50 vdcw
A19C7	0160-0174	C: fxd cer 0.47 pF -20% + 80% 25 vdcw
A19C8	0140-0178	C: fxd mica 560 pF 2%
A19C9	0160-0818	C: fxd cer 0.02 /pF 20% 50 vdcw
A19C10, 11	0180-0141	C: fxd elect alum 50 pF -10% + 75% 50 vdcw
A19CR1-5	1902-0049	Diode Si brkdwn 6.19 V 5% 400 mW
A19CR6, 7	1901-0040	Diode Si
A19CR8-13	1901-0028	Diode Si
A19Q1-8	1853-0036	Transistor PNP Si 2N3906
A19Q9-12	1854-0215	Transistor NPN Si 2N3904
A19R1	0758-0013	R: fxd met flm 120 $\Omega$ 5% 1/2 w
A19R2	0683-1535	R: fxd comp 15 K $\Omega$ 5% 1/4 w
A19R3	0683-1015	R: fxd comp 100 $\Omega$ 5% 1/4 w
A19R4	0758-0026	R: fxd met flm 82 $\Omega$ 5% 1/2 w
A19R5	0757-0346	R: fxd met flm 10, 5%, 114W.
A19R6	0683-1025	R: fxd comp 1 K $\Omega$ 5% 1/4 w
A19R7	0698-3497	R: fxd met flm 6.04 K $\Omega$ 1% 1/8 w
A19R8	0757-0200	R: fxd met flm 5.62 K $\Omega$ 1% 1/8 w
A19R9	0758-0013	R: fxd met flm 120 l 5% 1/2 w
A19R10	0683-1535	R: fxd comp 15 K $\Omega$ 5% 1/4 w
A19R11	0683-1015	R: fxd comp 100 $\Omega$ 5% 1/4 w
A19R12	0758-0026	R: fxd met flm 82 $\Omega$ 5% 1/2 w
A19R13	0757-0346.	R: fxd met flm 10 $\Omega$ , 5%, 1/4W.
A19R14, 15	0757-0439	R: fxd met flm 6.81 K $\Omega$ 1% 1/8 w
A19R16	0758-0026	R: fxd met flm 82 $\Omega$ 5% 1/2 w
A19R17	0683-1535	R: fxd comp 15 K $\Omega$ 5% 1/4 w
A19R18	0683-1015	R: fxd comp 100 $\Omega$ 5% 1/4 w
A19R19	0758-0026	R: fxd met flm 82 $\Omega$ 5% 1/2 w
A19R20	0757-0346	R: fxd met flm 10 $\Omega$ , 5%, 1/4W.
A19R21	0683-1025	R: fxd comp 1 K $\Omega$ 5% 1/4 w
A19R22	0698-3497	R: fxd met flm 6.04 K $\Omega$ 1% 1/8 w
A19R23	0757-0200	R: fxd met flm 5.62 K $\Omega$ 1% 1/8 w

TABLE 6-1. REFERENCE DESIGNATION INDEX (CONT)

REF.	STOCK NO.	DESCRIPTION
A20	04800-61020	MAGNITUDE SWITCH ASSEMBLY
A20L1	9140-0237	Coil fxd 200 pH
A20R1	0698-5453	R: fxd met flm 900 $\Omega$ 0.1% 1/8 w
A20R2	0698-4157	R: fxd met flm 10 K $\Omega$ 0.1% 1/8 w
A20R3	0698-4343	R: fxd met flm 100 $\Omega$ 0.1% 1/8 w
A20R4	0698-5453	R: fxd met flm 900 $\Omega$ 0.1% 1/8 w
A20R5	0698-4157	R: fxd met flm 10 K $\Omega$ 0.1% 1/8 w
A20R6	0698-4158	R: fxd met flm 100 K1 $\Omega$ 0.1% 1/8 w
A20R7	0698-5455	R: fxd met <i>flm</i> 9990 $\Omega$ 0.1% 1/8 w
A20R8	0698-5456	R: fxd met flm 90 $\Omega$ 0.1% 1/8 w
A20R9	0698-5459	R: fxd met flm 9900 $\Omega$ 0.1% 1/8 w
A20R10	0698-5457	R: fxd met flm 990 $\Omega$ 0.1% 1/8 w
A20R11	0698-5454	R: fxd met flm 9000 $\Omega$ 0.1% 1/8 w
A20R12	0698-5455	R: fxd met flm 9990 $\Omega$ 0.1% 1/8 w
A20R13	0683-560.5	R: fxd comp 56 $\Omega$ 5% 1/4 w
A20R14	0698-5452	R: fxd met flm 10 2 0.1% 1/8 w
A20S1	3100-1610	Switch less components
A21	04800-61021	OSCILLATOR SWITCH ASSEMBLY
A21R1	0698-5511	R: fxd met flm 50 M $\Omega$ 1% 2 watts.
A21R2	0698-5516	R: fxd met flm 5 M $\Omega$ 0.1% 2 watts
A21R3	0698-5451	R: fxd met flm 500 K $\Omega$ 0.1% 1/8 w
A21R4	0698-5450	R: fxd met flm 50 K $\Omega$ 0.1% 1/8 w
A21R5	0698-5449	R: fxd met flm 5 K $\Omega$ 0.1% 1/8 w
A21R6	0698-5511	R: fxd met <i>flm</i> 50 M $\Omega$ 1% 1 w
A21R7	0698-5516	R: fxd met flm 5 M $\Omega$ 0.1% 1 w
A21R8	0698-5451	R: fxd met flm 500 $\Omega$ 0.1% 1/8 w
A21R9	0698-5450	R: fxd met flm 50 K $\Omega$ 0.1% 1/8 w
A21R10	0698-5449	R: fxd met flm 5 K $\Omega$ 0.1% 1/8 w
A21S1A, B	3100-1611	Switch less components
A22	04800-61030	VARIABLE CAPACITOR ASSEMBLY
A22C1A, B	0121-0129	C: var air 2 sect 14.75/617.75 pF
A22C2	0160-2232	C: fxd mica 33 pF 2% 300 vdcw
A22C3	0160-0987	C: fxd mica 12 pF 5%
A22Q1		1855-0062..... Transistor field effect N Channel
	1855-0042	Transistor field effect N Channel 2N4303 (alt repl)
A22R1	0698-3113	R: fxd comp 100 Q2 5% 1/8 w
A22XQ1	1200-0148	Socket transistor teflon

TABLE 6-1. REFERENCE DESIGNATION INDEX (CONT)

REF.	STOCK NO.	DESCRIPTION
		CHASSIS COMPONENTS
C1	0180-0228	C: fxd ta 22 pF 10% 15 vdcw
C2	0160-2232	C: fxd mica 33 pF 2% 300 vdcw
C3		C : not used after serial prefix 816.
C4, 5	0180-1956	C: lxd alum 500 pF -10%IO + 751% 50 vdcw
C6	0150-0123	C: fxd cer 0.001 20% 250Vac.
CP1	1250-0076	Adapter BNC right angle Dend
CP2	1250-0216	Adapter BNC male-male <i>straight</i>
CP3	1250-0n76f	Adapter BNC right angle bend
C7	80160-2108	C: fxd cer 0.002 pF 20% 250Vac.
CR1, 2	1910-0016	Diode Ge
F1	or 21100201. 2110020.	Fuse cartridge 3 AG 1/2 A SLO BLO (115 V operation) Fuse cartridge 3 AG 1/4 A SLO BLO (230 V operation)
DS1	2140-0052	Lamp neon (P/O S2)
J1		P/O cable assembly 04800-61031
	1250-0140	J1 outer body only
	1250-0051	Center pin only
J2	1252-2357.	Power socket
J3-5	1250-0001	Connector BNC panel mtg jack
J6		P/O cable assembly 04800-61033
	1250-0140	J6 outer body only
	1250-0051	Center pin only
J7		P/O cable assembly 04800-61032
	1250-0140	J7 outer body only
	1250-0051	Center pin only
M1	1120-0339	Meter MAGNITUDE
M2	1120-0338	Meter PHASE ANGLE
Q1, 2	1854-0072	Transistor NPN Si 2N3054
R1		Not assigned
R2	2100-2399	R: var comp lin 100 Ω 20% 1/2 w
R3	2100-2386	R: var comp lin 100 KΩ 20% 1/2 w
R4	0757-0434	R: fxd met flm 3.65 KΩ 1% 1/8 w
R5	0683-3005	R: fxd comp 30 Ω 5% 1/4 w
R6	0686-3335	R: fxd comp 33 KΩ 5% 1/4 w
R7	2100-2291	R: var car comp 1 KΩ 10% 1/2 w
R8	2100-2290	R: var comp lin 500 SΩ 10% 1/2 w
R9	2100-2291	R: var car comp 1 KΩ 10% 1/2 w
R10	2100-2290	R: var comp lin 500 Ω 10% 1/2 w
R11	2100-0789	R: var comp lin 1 KΩ 10% 2.25 w
R12, 13	0683-4705	R: fxd comp 47 Ω 5% 1/4 w
S1	3101-0045	Switch slide DPDT
S2	3101-0852	Power Switch
53	3101-1234	Switch slide DPDT
T1	9100-0405	Power transformer
W1	8120-1348	Power cord
XA1-15	1251-0135	Connector PC board socket 15 pin
XA16-19	1251-0194	Connector PC board socket 15 pin
XA20-22		Not assigned
XA23	1251-0135	Connector PC board socket 15 pin
XQ1, 2		1200-0168..... Socket transistor TO-66

TABLE 6-2. REFERENCE DESIGNATION INDEX

REF.	STOCK NO.	DESCRIPTION
		4801A DIRECT MEASUREMENT PLUG-IN
	04800-22007	Printed Circuit Board Blank
C1	0121-0060	C: var cer 2-8 pF 300 vdcw
C2	0180-0137	C: fxd ta 100 pF 20% 10 vdcw
C3	0180-0155	C: fxd ta 2.2 pF 20% 20 vdcw
C4	0140-0195	C: fxd mica 130 pF 5% 300 vdcw
C5	0140-0200	C: fxd mica 390 pF 5% 300 vdcw
C6	0140-0202	C: fxd mica 15 pF 5% 500 vdcw
C7	0140-0203	C: fxd mica 30 pF 5%
C8	0140-0234	C: fxd mica 500 pF 1% 300 vdcw
C9	0140-0203	C: fxd mica 30 pF 5%
C10	0180-0155	C: fxd ta 2.2 pF 20% 20 vdcw
C11	0140-0234	C: fxd mica 500 pF 1% 300 vdcw
C12	0140-0191	C: fxd mica 56 pF 5% 300 vdcw
C13	0140-0200	C: fxd mica 390 pF 5% 300 vdcw
C14	0180-0155	C: fxd ta 2.2 pF 20% 20 vdcw
C15	0140-0200	C: fxd mica 390 pF 5% 300 vdcw
C16	0180-0155	C: fxd ta 2.2 pF 20% 20 vdcw
C17	0140-0200	C: fxd mica 390 pF 5% 300 vdcw
C18	0180-0224	C: fxd alum 10 AF -10% + 75% 15 vdcw
CR1, 2	1910-0016	Diode Ge
CR3, 4	1901-0040	Diode Si
E1	04800-81001	Transistors - 2N3904 matched pair
J1	04800-21002	Binding post
	1510-0029	Nut-binding post red
J2	04800-21002	Binding post
	1510-0029	Nut-binding post red
K1, 2	0490-0393	Relay reed SPDT
K3	0490-0339	Relay reed SPDT
K4	0490-0393	Relay reed SPYT
L1	9170-0894	Bead-ferrite
L2	9100-1618	Coil-choke 5.6 pH 10%
L3	9140-0179	Coil-choke 22 pH 10%
L4, 5	9100-1618	Coil-choke 5.6 pH 10%
L6		Not assigned
Q1	1853-0036	Transistor PNP Si 2N3906
Q2	1854-0215	Transistor NPN Si 2N3904
Q3	1853-0016	Transistor PNP Si 2N3638
Q4	1853-0036	Transistor PNP Si 2N3906
Q5	1854-0215	Transistor NPN Si 2N3904
Q6	1853-0036	Transistor PNP Si 2N3906
Q7, 8		Transistor NPN Si 2N3904 NSR P/O EI
Q9	1853-0036	Transistor PNP Si 2N3906
Q10, 11	1854-0215	Transistor NPN Si 2N3904
R1	0683-4755	R: fxd comp factory selected typical 4.7 M $\Omega$ 5% 1/4 w
R2	0683-1035	R: fxd comp 10 K $\Omega$ 5% 1/4 w
R3	0757-0449	R; fxd met flm 20 K $\Omega$ 1% 1/8 w
R4	0757-0273	R: fxd met flm 3.01 K $\Omega$ 1% 1/8 w
R5	0698-4406	R: fxd met flm 115 $\Omega$ 1% 1/8 w
R6	0757-0280	R: fxd met flm 1 K $\Omega$ 1% 1/8 w
R7, 8	0698-3226	R: fxd met flm 6.49 K $\Omega$ 1% 1/8 w

TABLE 6-1. REFERENCE DESIGNATION INDEX (CONT)

REF.	STOCK NO.	DESCRIPTION
R9	0757-0449	R: fxd met flm 20 K $\Omega$ 1% 1/8 w
R10	0698-4406	R: fxd met flm 115 $\Omega$ 1% 1/8 w
R11	0757-0273	R: fxd met flm 3.01 K $\Omega$ 1% 1/8 w
R12, 13	0683-1015	R: fxd comp 100 $\Omega$ 5% 1/4 w
R14	0757-0427	R: fxd met flm 1.5 K $\Omega$ 1% 1/8 w
R15	0698-4123	R: fxd met flm 499 $\Omega$ 1% 1/8 w
R16	2100-1773	R: var ww lin 1 K $\Omega$ 10% 1/2 w
R17	0698-0083	R: fxd met flm 1.96 K $\Omega$ 1% 1/8 w
R18	0683-1005	R: fxd comp 10 $\Omega$ 5% 1/4 w
R19	0698-3497	R: fxd met flm 6.04 K $\Omega$ 1% 1/8 w
R20	0683-2015	R: fxd comp 200 $\Omega$ 5% 1/4 w
R21	0698-3226	R: fxd met flm 6.49 K $\Omega$ 1% 1/8 w
R22	0757-0442	R: fxd met flm 10 K $\Omega$ 1% 1/8 w
R23	0757-0401	R: fxd met flm 100 $\Omega$ 1% 1/8 w
R24, 25	0757-0437	R: fxd met flm 4.75 K $\Omega$ 1% 1/8 w
R26	0683-1005	R: fxd comp 10 $\Omega$ 5% 1/4 w
R27	0683-2015	R: fxd comp 200 $\Omega$ 5% 1/4 w
R28	0683-5105	R: fxd comp 51 $\Omega$ 5% 1/4 w
R29	0757-0442	R: fxd met flm 10 K $\Omega$ 1% 1/8 w
R30	0683-2015	R: fxd comp 200 $\Omega$ 5% 1/4 w
R31	0683-1805	R: fxd comp 18 $\Omega$ 5% 1/4 w
R32	0757-0427	R: fxd met flm 1.5 K $\Omega$ 1% 1/8 w
R33	0698-4343	R: fxd met flm 100 $\Omega$ 0.1% 1/8 w
R34	0698-5453	R: fxd met flm 9P0 $\Omega$ 0.1% 1/8 w
R35s	0698-5456	R: fxd met flm 90 0 $\Omega$ 0.1% 1/8 w
R36	0698-5452	R: fxd met flm 10 $\Omega$ 0.1% 1/10 w
R37	0683-6805	R: fxd comp 68 $\Omega$ 5% 1/4 w
R38	0757-0280	R: fxd met flm 1 K $\Omega$ 1% 1/8 w

TABLE 6-3. REPLACEABLE PARTS INDEX

Figure 6-1 Index No.	Stock No.	Description	Qty.
1	2360-0182	Screw-machine 6-32 x 5/16 FH POZI SS .....	8
2	5060-0740	Cover-top .....	1
3	04800-01009	Shield-oscillator compartment.....	1
4	2420-0009	Nut-hex 6-32 1/4 AF 3/32 THK SS .....	9
5	2190-0006	Lockwasher helical No. 6 heavy SS .....	8
6	-----	C8 see Table 6-1	
7	1400-0265	Strap-cable for 1-3/4 D cable nylon.....	2
8	0360-0402	Terminal strip 2 INS 1 GRD .....	1
9	-----	C9 see Table 6-1	
10	1200-0168	Socket-transistor for TO-66 case .....	2
11	0360-0364	Terminal strip 2 INS 1 GRD .....	1
12	0340-0140	Insulator-transistor mica .....	2
13	-----	Q1 see Table 6-1	
14	0624-0078	Screw-tapping 6-32 x 3/8 PH POZI STL CP .....	4
15	5040-0631	Bracket-capacitor MTG.....	2
16	2360-0197	Screw-machine 6-32 x 3/8 PH POZI SS .....	22
17	04800-01017	Bracket-transistor MTG.....	1
18	1200-0148	Socket-transistor 3 pin teflon .....	1
19	-----	C1 see Table 6-1	
20	3050-0010	Washer-flat 3/16 PD BRS NP No. 6.....	4
21	04800-01010	Cover-oscillator compartment.....	1
22	1460-0156	Spring .136D .346L 7T.....	1
23	04800-21004	Pulley analog drive .....	1
24	04800-61041	String assembly-analog drive.....	1
25	04800-21001	Pulley-capacitor drive .....	1
26	04800-61040	String assembly-capacitor drive.....	1
27	1460-0154	Spring .125D . 625L 12T.....	1
28	04800-21003	Pulley-capacitor drive .....	1
29	2200-0103	Screw-machine 4-40 x 1/4 PH POZI SS W/LOCK .....	4
30	04800-61021	Switch assembly-FREQ RANGE.....	1
31	2950-0069	Nut-hex 3/8-32 1/2 AF 3/32 THK SS .....	3
32	2190-0022	Lockwasher INT PH BRZ' NP HEAVY for 3/8 stud.....	3
33	0510-0228	Ring-retaining EXT E type 1/4 SHFT.....	1
34	1410-0760	Bearing-ball flanged 5/8 OD x 1/4 ID.....	1
35	04800-01002	Panel-sub .....	1
36	-----	R11see Table 6-1	
37	04800-21005	Shaft-drive.....	1
38	3030-0160	Screw-set 6-32 x 3/4 HEX DR CUP PT .....	1
39	2260-0002	Nut-hex 4-40 3/16 AF 1/16 THK SS .....	9
40	2190-0086	Lockwasher helical No. 4 light PH BRZ NP .....	9
41	3030-0033	Screw-set 6-32 x 3/16 hex DR CUP PT .....	1
42	1500-0033	Ball-drive 6-1 reduction.....	1
43	3101-0100	Switch-pushbutton SPDT lighted red lens.....	1
44	3050-0294	Washer-flat 9/32 OD BRS NP No. 4.....	2
45	04800-01001	Panel-front.....	1
46	7120-1254	Plate-identification .....	1
47	2200-0139	Screw-machine 4-40 x 1/4 PH POZI SS .....	1
48	2200-0141	Screw-machine 4-40 x 5/16 PH POZI SS .....	1
49	04800-21010	Indicator .....	1
50	2200-0141	Screw-machine 4-40 x 5/16 PH POZI SS .....	2
	5040-0305	Lamp Base	



TABLE 6-3. REPLACEABLE PARTS INDEX

Figure 6-1 Index No.	Stock No.	Description	Qty.
51	5000-3021	Dial-FREQUENCY .....	1
52	2190-0094	Lockwasher helical medium PH BRZ No. 2 .....	2
53	0520-0024	Screw-machine 2-56 x 3/16 BH SD SS .....	2
54	0370-0141	Knob-assembly tuning .....	1
55	0370-0041	Knob-crank P/O 54 .....	1
56	1410-0033	Bushing-knob P/O 54.....	1
57	0370-0050	Knob-round 3/8 D BLK P/O 54 .....	1
58	2410-0001	Screw-machine 6-32 x 5/8 OH PD SS P/O 54 .....	1
59	2140-0224	Lamp-glow 115 V T-2 bulb wire terminals P/O 43 .....	1
60	0400-0084	Bushing-snap 1/4 ID BLK NYLON.....	2
61	0370-0090	Knob-skirted bar 5/8 D BLK W/2 ARROWS .....	1
62	0370-0077	Knob-skirted bar 5/8 D BLK W/ARROW.....	1
63	1490-0030	Stand-tilt.....	1
64	5060-0767	Foot assembly .....	4
65	5060-0752	Cover-bottom .....	1
66	00741-01209	Bracket-meter retaining.....	2
67		M1 see Table 6-1	
68		M2 see Table 6-1	
69	04800-01013	Guide-Plug-in .....	1
70	2420-0001	Nut-hex 6-32 5/16 AF 7/64 THK STL W/LOCK .....	4
71	04800-61020	Switch assembly Z MAGNITUDE .....	1
72	186A-55B	Shield-cover .....	1
73	186A-55B1	Clamp-shield .....	1
74	5000-0051	Plate-fluted aluminum.....	2
75	2190-0048	Lockwasher EXT PH BRZ NP No. 8 countersunk .....	12
76	2510-0123	Screw-machine 8-32 x 1/2 FH POZI SS .....	12
77	5060-0766	Retainer-handle assembly .....	2
78	5060-0763	Handle assembly-side.....	2
79	5000-0737	Cover-cabinet front side.....	2
80	2200-0165	Screw-machine 4-40 x 1/4 FH POZI SS .....	8
81	2510-0101	Screw-machine 8-32 x 5/16 PH POZI SS .....	4
82	2190-0087	Lockwasher helical medium SS No. 8 .....	4
83	1460-0090	Spring-torsion P/O 78 .....	2
84	5000-0736	Cover-cabinet rear side.....	2
85	5060-0732	Frame-side (on this assembly are 0590-0052 nut, sheet qty 8) .....	2
86	5060-2693	Board-extender 15 pin (supplied accessory).....	1
87	2200-0107	Screw-machine 4-40 x 3/8 PH POZI SS W/LOCK .....	1
88	2200-0139	Screw-machine 4-40 x 1/4 PH POZI SS .....	2
89	04800-01005	Shelf-oscillator.....	1
90	2360-0201	Screw-machine 6-32 x 1/2 PH POZI SS .....	4
91	04800-01018	Plate-side .....	1
92	04800-01015	Shield.....	1
93		Deleted	
94	04800-01004	Shield-channel.....	1
95	04800-01003	Connector-shelf .....	1
96	1250-0140	Body-RF connector BNC bulkhead mtg.....	3
97	2950-0006	Nut-hex 1/4-32 3/8 AF 3/32 THK BRS NP .....	2
98	2190-0027	Lockwasher INT PH BRZ NP for 1/4 stud.....	2
99	04800-01008	Panel-rear .....	1
100	1251-1189	Connector-female banana type .....	2

TABLE 6-3. REPLACEABLE PARTS INDEX

Figure 6-1 Index No.	Stock No.	Description	Qty.
101	1251-0013	Connector-male banana type .....	2
102	13525A	Resistor calibration .....	1
103	1250-0076	Connector-RF BNC adapter RT angle .....	2
104	1250-0216	Connector-RF BNC adapter plug to plug straight.....	1
105	-----	R8 see Table 6-1	
106	2190-0084	Lockwasher INT STL CP 1/4 stud .....	4
107	2950-0006	Nut-hex 1/4-32 3/8 AF 3/32 THK BRS NP .....	4
108	0370-0125	Knob-round 1/2 D BLK 1/8 SHFT .....	4
109	1250-0001	Connector-RF BNC bulkhead MTG jack .....	3
110	2190-0016	Lockwasher INT PH BRZ NP for 3/8 stud .....	3
111	2950-0001	Nut-hex 3/8-32 1/2 AF 3/32 THK BRS NP .....	3
112	1400-0029	Cap-extractor fuse post P/O 114 .....	1
113		F1 see Table 6-1	
114	1400-0084	Holder-fuse extractor post type for 3AG .....	1
115	1400-0090	Washer-neoprene 5/8 OD 1/2 ID 1/32 THK P/O 114 .....	1
116	2190-0037	Lockwasher INT STL CP for 1/2 stud P/O 114 .....	1
117	2950-0038	Nut-hex 1/2-24 11/16 AF 1/8 THK STL CP P/O 114 .....	1
118	1251-0184	Connector-AC power 3 pin receptacle .....	1
119	3101-0033	Switch-slide DPDT marked 115/230.....	1
120	9100-0405	Transformer-power .....	1
140	00610A	Shield-terminal(supplied accessory).....	1
141	1510-0029	Nut-binding post red W/O insert.....	2
142	04800-21002	Post-binding .....	2
143	0340-0718,	Insulator-binding post .....	2
144	04800-21008	Screw-captive .....	2
145	04800-01011	Panel-4801A Plug-in .....	2
146	-----	Printed circuit board assembly see Table 6-2 .....	1
147	04800-01012	Frame Plug-in.....	1
148	2200-0141	Screw-machine 4-40 x 5/16 PH POZI SS .....	4
149	2740-0001	Nut-hex 10-32 5/16 AF 7/64 THK SS.....	2
150	2190-0012	Lockwasher EXT PH BRZ NP No. 10 .....	2
151	3050-0257	Washer-flat 7/16 OD BRS NP No. 10 screw.....	2
152	0340-0719	Insulator-binding post .....	2
153	04801-00001	shield, for reed relay K1.	

## REFERENCE DESIGNATION





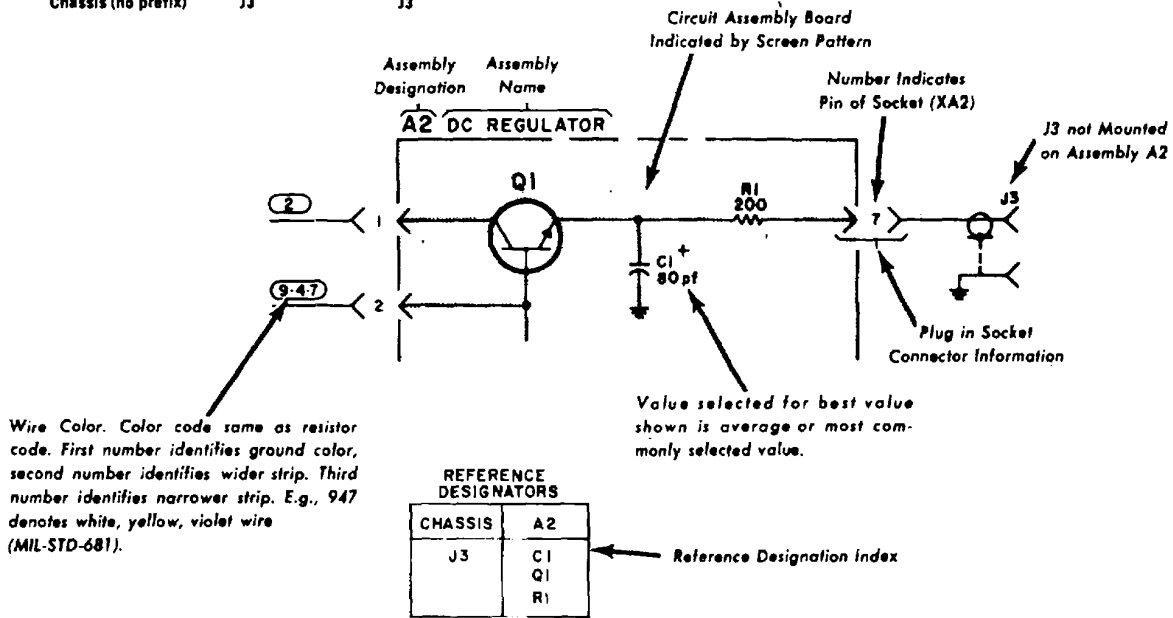





Reference designations on assembly boards (printed circuit boards) are abbreviated. Add assembly number to abbreviation for complete description.







Assembly	Abbreviation	Complete Designations
A5	C1	ASC1
A13A1	R8	A13A1R
Chassis (no prefix)	J3	J3



### SYMBOLS

Resistance in ohms, capacitance in microfarads, inductance in microhenries unless otherwise noted.

-  Screwdriver adjustment.
-  Knob control
-  Encloses front panel designation
-  Encloses rear panel designation
-  Circuit assembly borderline
-  Other assembly borderline
-  Heavy line with arrows indicates path and direction of main signal.
-  Heavy dashed line with arrows indicates path and direction of main feedback.
-  Indicates main path of auxiliary signal
-  Powerline (chassis) ground

-  Etched circuit board common ground
-  Waveform test point
-  9-1-8 Denotes wire color using standard color code (e.g. 9-1-8 == white-brown-grey)
-  Voltage regulator (breakdown) diode.
-  Step recovery diode
-  Field effect transistor with P-material base

### SWITCH DESIGNATION

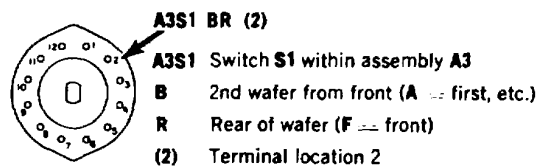

**SECTION VII  
CIRCUIT DIAGRAMS****7-1. INTRODUCTION**

7-2. This section contains schematic diagrams for the Model 4800A and Model 4801A. Wiring diagrams are not included, although wire colors are given on the schematics where practical. Refer to Table 7-1 for general notes and an explanation of symbols used in the diagrams. Each schematic diagram contains a table which lists all the reference designators that appear on that diagram.

**7-3. ASSEMBLY AND COMPONENT IDENTIFICATION**

7-4. The functional block diagram in Figure 7-1 includes top and bottom photographs of the instrument to be used as an aid to identifying assemblies, calibration adjustments, and chassis components. Each printed circuit assembly and its components are illustrated with the schematic of the particular assembly. In addition, each illustration shows the etched wiring on BOTH sides of the circuit board as aid to selecting suitable test points when troubleshooting.

**7-5. WAVEFORMS AND VOLTAGE MEASUREMENTS**

7-6. Voltage measurements and meaningful waveforms are provided with the schematic diagrams as aids to troubleshooting. Measurements should not be considered as performance specifications since they can vary with component tolerances and temperature. Waveforms in all circuits are sinusoidal except in the phase detection circuits. Unless otherwise indicated, measurements were taken with the 13525A Calibration Resistor on the measurement terminals, the test frequency at 1.59 kHz, and the IMPEDANCE MAGNITUDE switch set to X100.

**7-7. TALKING SCHEMATICS**

7-8. Detailed information on the operation of each circuit in this section will be found on the page facing each schematic. The information is placed in blocks of text placed directly over a circuit schematic. In this form they allow the reader to follow the descriptions and to refer to the circuitry as easily as possible. Questions on the operation of a circuit can then be answered quickly.

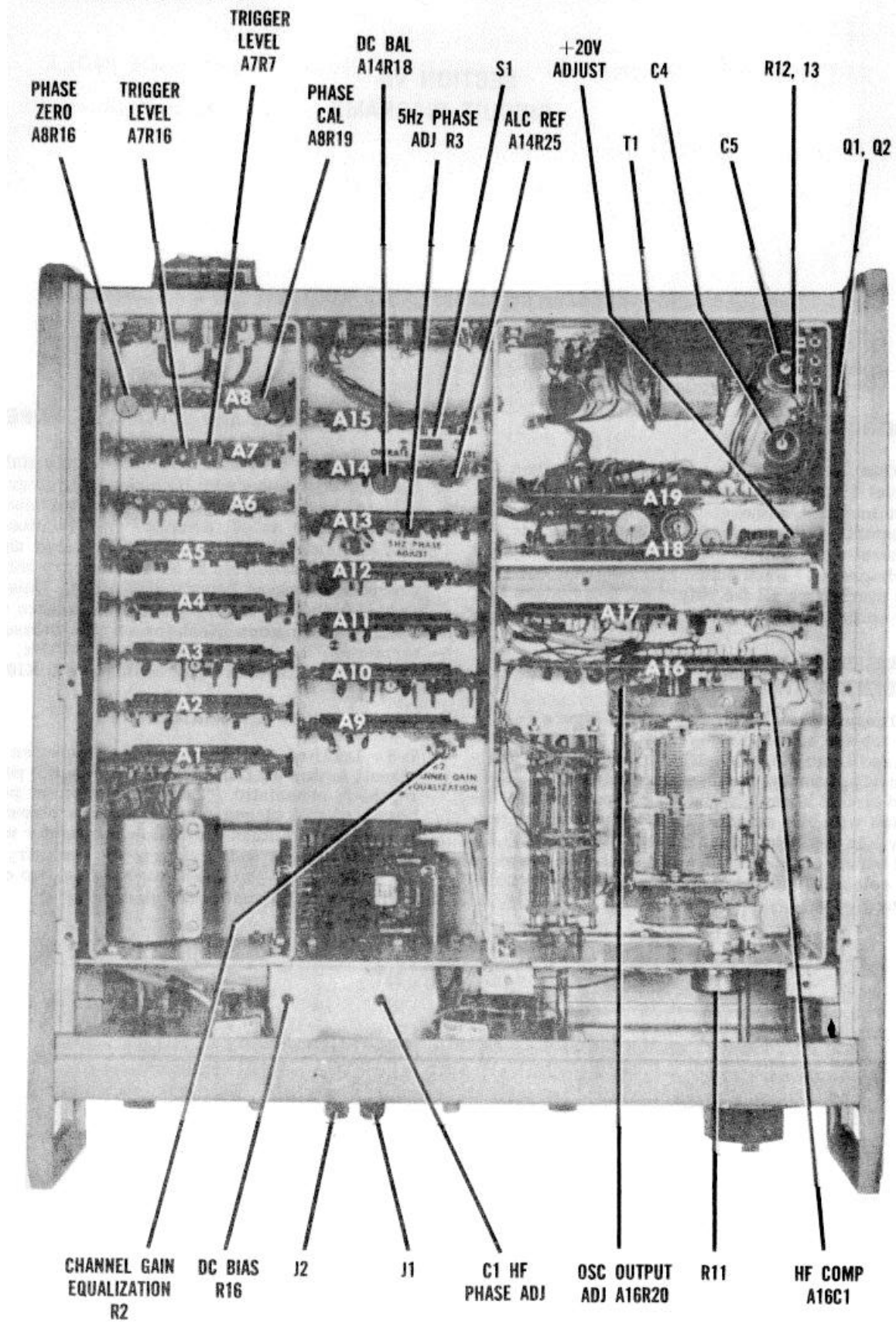

**SECTION VIII****PART NUMBER-NATIONAL STOCK NUMBER CROSS REFERENCE INDEX****8-1. Scope**

The index in this section of the technical manual is to be used when requisitioning parts from the commercial arts list in Section VI of this manual.

**8-2. How to Order**

Wherever the commercial part number appears to have

a valid national stock number, order through the normal requisitioning channels. Should you need a part which is not listed with a national stock number, you may order by the exception supply ordering procedures using the FSCM 28480 followed by the manufacturer's part number from Section VI.

**PART NUMBER-NATIONAL STOCK NUMBER  
CROSS REFERENCE INDEX**

<b>PART NUMBER</b>	<b>FSCM</b>	<b>NATIONAL STOCK NUMBER</b>	<b>PART NUMBER</b>	<b>FSCM</b>	<b>NATIONAL STOCK NUMBER</b>
0121-0060	28480	5910-00-767-4977	0370-0141	28480	5355-00-520-1732
0121-0105	28480	5910-00-761-1216	0490-0393	28480	5945-00-454-7393
0140-0191	28480	5910-00-615-7474	0490-0399	28480	5945-00-477-9296
0140-0192	28480	5910-00-914-4730	0683-1005	28480	5905-00-960-0099
0140-0195	28480	5910-00-776-8913	0683-1015	28480	5905-00-102-5294
0140-0200	28480	5910-00-914-4732	0683-1035	28480	5905-00-998-1929
0140-0202	28480	5910-00-852-2655	0683-1205	28480	5905-00-497-5610
0140-0203	28480	5910-00-933-7538	0683-2015	28480	5905-00-683-2239
0140-0234	28480	5910-00-494-5056	0683-2025	28480	5905-00-686-3370
0150-0093	28480	5910-00-542-2010	0683-3005	28480	5905-00-402-4248
0150-0119	28480	5910-00-961-4204	0683-3355	28480	5905-00-402-4264
0160-0157	28480	5910-00-961-9591	0683-3915	28480	5905-00-931-1062
0160-0174	28480	5910-00-234-9817	0683-4755	28480	5905-00-498-6062
0160-0207	28480	5910-00-057-8094	0683-5115	28480	5905-00-801-8272
0160-0335	28480	5910-00-411-3606	0698-0083	28480	5905-00-407-0052
0160-0938	28480	5910-00-138-1320	0698-3113	28480	5905-00-420-7127
0160-0987	28480	5910-00-841-7018	0698-3153	28480	5905-00-974-6081
0160-2198	28480	5910-00-430-5647	0698-3403	28480	5905-00-469-2957
0170-0019	28480	5910-00-892-7784	0698-3498	28480	5905-00-478-2244
0180-0137	28480	5910-00-915-1393	0698-3558	28480	5905-00-407-0061
0180-0139	28480	5910-00-007-3988	0698-4014	28480	5905-00-138-5053
0180-0141	28480	5910-00-879-0123	0698-4121	28480	5905-00-998-1916
0180-0158	28480	5910-00-775-9093	0698-4123	28480	5905-00-998-1915
0180-0228	28480	5910-00-719-9907	0698-4484	28480	5905-00-140-5675
0180-0374	28480	5910-00-931-7050	0757-0200	28480	5905-00-891-4224
0180-1702	28480	5910-00-430-5999	0757-0273	28480	5905-00-193-4294
0340-0140	28480	5970-00-088-5074	0757-0274	28480	5905-00-858-9105
0370-0041	28480	5355-00-896-9949	0757-0280	28480	5905-00-853-8190
0370-0050	28480	5355-00-579-2318	0757-0288	28480	5905-00-193-4318
0370-0077	28480	5355-00-767-9444	0757-0401	28480	5905-00-981-7529

**PART NUMBER-NATIONAL STOCK NUMBER  
CROSS REFERENCE INDEX**

<b>PART NUMBER</b>	<b>FSCM</b>	<b>NATIONAL STOCK NUMBER</b>	<b>PART NUMBER</b>	<b>FSCM</b>	<b>NATIONAL STOCK NUMBER</b>
0757-0408	28480	5905-00-781-2980	1251-0194	28480	5935-00-948-9078
0757-0411	28480	5905-00-056-0451	1400-0084	28480	5920-00-881-4636
0757-0416	28480	5905-00-998-1795	1400-0090	28480	5970-01-005-2884
0757-0419	28480	5905-00-891-4213	1410-0033	28480	6625-00-818-5973
0757-0427	28480	5905-00-917-0578	1490-0030	28480	6625-00-760-9521
0757-0431	28480	5905-00-493-0749	1853-0009	28480	5961-00-955-7708
0757-0434	28480	5905-00-998-1793	1853-0016	28480	5961-00-901-4862
0757-0435	28480	5905-00-858-9148	1853-0036	28480	5961-00-931-0372
0757-0436	28480	5905-00-858-6792	1854-0072	28480	5961-00-761-9379
0757-0437	28480	5905-00-904-4404	1854-0215	28480	5961-00-892-8706
0757-0439	28480	5905-00-990-0303	1855-0062	28480	5961-00-222-6451
0757-0440	28480	5905-00-858-6795	1901-0028	28480	5961-00-951-1505
0757-0442	28480	5905-00-998-1792	1901-0040	28480	5961-00-965-5917
0757-0446	28480	5905-00-858-8895	1902-0018	28480	5961-00-931-7021
0757-0447	28480	5905-00-981-7530	1902-0049	28480	5961-00-911-9277
0757-0449	28480	5905-00-891-2809	1902-0071	28480	5961-00-835-9974
0757-0465	28480	5905-00-904-4412	1910-0016	28480	5961-00-954-9182
0757-0827	28480	5905-00-930-7958	1910-0022	28480	5961-00-690-9341
0758-0013	28480	5905-00-978-5045	2100-0789	28480	5905-00-982-8423
0758-0026	28480	5905-00-978-5050	2100-1755	28480	5905-00-407-0078
1200-0168	28480	5935-00-124-5081	2100-1757	28480	5905-00-407-0079
1205-0033	28480	5999-00-871-9538	2100-1758	28480	5905-00-228-5989
1250-0001	28480	5935-00-027-6759	2100-1773	28480	5905-00-115-7158
1250-0051	28480	5999-00-882-6993	2100-2290	28480	5905-00-451-2537
1250-0076	28480	5935-00-081-8799	2190-0006	28480	5310-00-801-6079
1250-0140	28480	5935-00-966-4457	2200-0103	28480	5305-00-492-8796
1250-0216	28480	5935-00-982-7620	2200-0107	28480	5305-00-094-4541
1251-0013	28480	5935-00-909-2687	2200-0139	28480	5305-00-574-0351
1251-0135	28480	5935-00-972-9464	2200-0141	28480	5305-00-587-7645
1251-0148	28480	5935-00-058-9423	2260-0002	28480	5310-00-997-3078



**PART NUMBER-NATIONAL STOCK NUMBER  
CROSS REFERENCE INDEX**

<b>PART NUMBER</b>	<b>FSCM</b>	<b>NATIONAL STOCK NUMBER</b>	<b>PART NUMBER</b>	<b>FSCM</b>	<b>NATIONAL STOCK NUMBER</b>
2360-0197	28480	5305-00-587-7626			
2360-0201	28480	5305-00-598-6650			
2420-0001	28480	5310-00-687-7337			
2950-0001	28480	5310-00-450-3324			
3101-0033	28480	5930-00-977-1760			
3101-0045	28480	5930-00-402-6752			
3101-0100	28480	5930-00-918-4381			
5000-0051	28480	6625-00-412-1204			
5060-0049	28480	6625-00-850-2241			
5060-0732	28480	6625-00-155-5798			
5060-0763	28480	5865-00-934-1344			
5060-0766	28480	6625-00-818-4575			
5060-0767	28480	6625-00-903-0348			
8120-0078	28480	5995-00-995-9822			
9100-1618	28480	5950-00-431-3196			
9140-0107	28480	5950-00-865-9044			
9140-0179	28480	5950-00-225-2177			
9140-0237	28480	5950-00-431-3216			

**APPENDIX A  
REFERENCES**

---

DA PAM 310-4	Index of Technical Publications: Technical Manuals, Technical Bulletins, Supply Manuals (Types 7, 8, and 9), Supply Bulletins, Modification Work Orders and Lubrication Orders.
TM 38-750	The Army Maintenance Management System (TAMMS).
TM 750-244-2	Procedures for Destruction of Electronics Materiel to Prevent Enemy Use (Electronics Command).

## APPENDIX B MAINTENANCE ALLOCATION

### Section I. INTRODUCTION

#### B-1. General.

This appendix provides a summary of the maintenance operation for ZM-74/U. It authorizes categories of maintenance for specific maintenance functions on repairable items and components and the tools and equipment required to perform each function. This appendix may be used as an aid in planning maintenance operations.

#### B-2. Maintenance Function.

Maintenance functions will be limited to and defined as follows:

a. *Inspect.* To determine the serviceability of an item by comparing its physical, mechanical, and/or electrical characteristics with established standards through examination.

b. *Test.* To verify serviceability and to detect incipient failure by measuring the mechanical or electrical characteristics of a item and comparing those characteristics with prescribed standards.

c. *Service.* Operations required periodically to keep an item in proper operating condition, i.e., to clean (decontaminate), to preserve, to drain, to paint, or to replenish fuel, lubricants, hydraulic fluids, or compressed air supplies.

d. *Adjust.* To maintain, within prescribed limits, by bringing into proper or exact position, or by setting the operating characteristics to the specified parameters.

e. *Align.* To adjust specified variable elements of an item to bring about optimum or desired performance.

f. *Calibrate.* To determine and cause corrections to be made or to be adjusted on instruments or test measuring and diagnostic equipments used in precision measurement. Consists of comparisons of two instruments, one of which is a certified standard of known accuracy, to detect and adjust any discrepancy in the accuracy of the instrument being compared.

g. *Install.* The act of emplacing, seating, or fixing into position an item, part, module (component or assembly) in a manner to allow the proper functioning of the equipment or system.

h. *Replace.* The act of substituting a serviceable like type part, subassembly, or module (component or assembly) for an unserviceable counterpart.

i. *Repair.* The application of maintenance services (inspect, test, service, adjust, align, calibrate, replace) or other maintenance actions (welding, grinding, riveting, straightening, facing, remachining, or resurfacing) to restore serviceability to an item by correcting specific damage, fault, malfunction, or failure in a part, subassembly, module (component or assembly), end item, or system.

j. *Overhaul.* That maintenance effort (service/action) necessary to restore an item to a completely serviceable/operational condition as prescribed by maintenance standards (i.e., DMWR) in appropriate technical publications. Overhaul is normally the highest degree of maintenance performed by the Army. Overhaul does not normally return an item to like new condition.

k. *Rebuild.* Consists of those services/actions necessary for the restoration of unserviceable equipment to a like new condition in accordance with original manufacturing standards. Rebuild is the highest degree of materiel maintenance applied to Army equipment. The rebuild operation includes the act of returning to zero those age measurements (hours, miles, etc.) considered in classifying Army equipment/components.

#### B-3. Column Entries.

a. *Column 1, Group Number.* Column 1 lists group numbers, the purpose of which is to identify components, assemblies, subassemblies, and modules with the next highest assembly.

b. *Column 2, Component/Assembly.* Column 2 contains the noun names of components, assemblies, subassemblies, and modules for which maintenance is authorized.

c. *Column 3, Maintenance Functions.* Column 3 lists the functions to be performed on the item listed in column 2. When items are listed without maintenance functions, it is solely for purpose of having the group numbers in the MAC and RPSTL coincide.

d. *Column 4, Maintenance Category.* Column 4 specifies, by the listing of a "work time" figure in the appropriate subcolumn(s), the lowest level of maintenance authorized to perform the function listed in column 3. This figure represents the active time required to perform that maintenance function at the indicated category of maintenance. If the number or complexity of the tasks within the listed maintenance function vary at different maintenance categories, appropriate "work time" figures will be shown for each category. The number of task-hours specified by the "work time" figure represents the average time required to restore an item (assembly, subassembly, component, module, end item or system) to a serviceable condition under typical field operating conditions. This time includes preparation time, troubleshooting time, and quality assurance/quality control time in addition to the time required to perform the specific tasks identified for the maintenance functions authorized

in the maintenance allocation chart. Subcolumns of column 4 are as follows:

- C - Operator/Crew
- O - Organizational
- F - Direct Support
- H - General Support
- D - Depot

e. *Column 5, Tools and Equipment.* Column 5 specifies by code, those common tool sets (not individual tools) and special tools, test, and support equipment required to perform the designated function.

f. *Column 6, Remarks.* Column 6 contains an alphabetic code which leads to the remark in section IV, Remarks, which is pertinent to the item opposite the particular code.

**B-4. Tool and Test Equipment Requirements (Sect. III).**

a. *Tool or Test Equipment Reference Code.* The numbers in this column coincide with the numbers used in the tools and equipment column of the MAC. The numbers indicate the applicable tool or test equipment for the maintenance functions.

b. *Maintenance Category.* The codes in this column indicate the maintenance category allocated the tool or test equipment.

c. *Nomenclature.* This column lists the noun name and nomenclature of the tools and test equipment required to perform the maintenance functions.

d. *National/NATO Stock Number.* This column lists the National/NATO stock number of the specific tool or test equipment.

e. *Tool Number.* This column lists the manufacturer's part number of the tool followed by the Federal Supply Code for manufacturers (5-digit) in parentheses.

**B-5. Remarks (Sect. IV).**

a. *Reference Code.* This code refers to the appropriate item in section II, column 6.

b. *Remarks.* This column provides the required explanatory information necessary to clarify items appearing in section II.

**SECTION II MAINTENANCE ALLOCATION CHART  
FOR  
IMPEDANCE METER: VECTOR, ZM-74/U**

(1) GROUP NUMBER	(2) COMPONENT ASSEMBLY	(3) MAINTENANCE FUNCTION	(4) MAINTENANCE CATEGORY					(5) TOOLS AND EQUIPMENT	(6) REMARKS
			C	O	F	H	D		
00	BRIDGE CAPACITANCE: ZM-74/U	Inspect Service Test Adjust Repair Repair Overhaul	0.1 0.2				0.8 0.5 0.5 1.0 1.5	Visual None 1 thru 7 2 thru 7 7 7 7	
01	UTILITY AMPLIFIER (5 identical: A1, A2, A4, A9, A11)	Test Replace Repair Overhaul					0.3 0.3 0.2 0.3	1 thru 7 7 7 7	
02	BANDPASS FILTER (2 identical: A3, A10)	Test Replace Repair Overhaul					0.3 0.3 0.2 0.3	1 thru 7 7 7 7	
03	DETECTOR (2 identical: AS, A12)	Test Replace Repair Overhaul					0.3 0.3 0.2 0.3	1 thru 7 7 7 7	
04	FILTER AMPLIFIER (2 identical: A6, A13)	Test Replace Repair Overhaul					0.3 0.3 0.2 0.3	1 thru 7 7 7 7	
05	SCHMITT TRIGGER A7	Test Replace Repair Overhaul					0.3 0.3 0.2 0.3	1 thru 7 7 7 7	
06	PHASE DETECTOR A8	Test Replace Repair Overhaul					0.3 0.3 0.2 0.3	1 thru 7 7 7 7	
07	DC AMPLIFIER A14	Test Replace Repair Overhaul					0.3 0.3 0.2 0.3	1 thru 7 7 7 7	
08	ANALOG BOARD A15	Test Replace Repair Overhaul					0.3 0.3 0.2 0.3	1 thru 7 7 7 7	
09	OSCILLATOR A16	Test Replace Repair Overhaul					0.3 0.3 0.2 0.3	1 thru 7 7 7 7	
10	AGC AND MONITOR AMPLIFIER A17	Test Replace Repair Overhaul					0.3 0.3 0.2 0.3	1 thru 7 7 7 7	
11	20V REGULATOR A18	Test Replace Repair Overhaul					0.3 0.3 0.2 0.3	1 thru 7 7 7 7	
12	RECTIFIER AND 14V REGULATORS A19	Test Replace Repair Overhaul					0.3 0.3 0.2 0.3	1 thru 7 7 7 7	

**SECTION II MAINTENANCE ALLOCATION CHART  
FOR  
IMPEDANCE METER: VECTOR, ZM-74/U**

(1)	(2)	(3)	(4)					(5)	(6)
			MAINTENANCE CATEGORY						
GROUP NUMBER	COMPONENT ASSEMBLY	MAINTENANCE FUNCTION	C	O	F	H	D	TOOLS AND EQUIPMENT	REMARKS
13	MAGNITUDE SWITCH A20	Test				0.3			
		Replace				0.3			
		Repair						0.2	
		Overhaul						0.3	
14	OSCILLATOR SWITCH A21	Test				0.2			
		Replace				0.3			
		<b>Repair</b>						<b>0.1</b>	
		Overhaul						0.2	
15	VARIABLE CAPACITOR A22	Test				0.2			
		Replace				<b>0.5</b>			
		Repair						0.2	
		Overhaul						0.3	
16	DIRECT MEASUREMENT PLUG-IN A23 4801A	Test				0.3			1 thru 7
		Replace				0.3			7
		Repair						0.2	7
		Overhaul						0.3	7

**SECTION III. TOOL AND TEST EQUIPMENT REQUIREMENTS FOR  
IMPEDANCE METER: VECTOR, ZM-74/U**

(1) TOOL OR TEST EQUIPMENT REF CODE	(2) MAINTENANCE LEVEL	(3) NOMENCLATURE	(4) NATIONAL/NATO STOCK NUMBER	(5) TOOL NUMBER
1	H, D	OSCILLOSCOPE AN/USM-281C	6625-00-106-9622	
2	H, D	VOLTMETER, DIGITAL AN/GSM-64B	6625-00-022-7894	
3	H, D	COUNTER, ELECTRONIC AN/USM-459	6625-01-061-8928	
4	H, D	VOLTMETER, ELECTRONIC ME-459	6625-00-229-0457	
5	H, D	MULTIMETER AN/USM-223	6625-00-999-7465	
6	H, D	TRANSFORMER, VARIABLE POWER CN-16/U	5950-00-235-2086	
7	H, D	Common tools necessary to the performance of this maintenance function are available to maintenance personnel for the maintenance category listed.		

\*U.S. GOVERNMENT PRINTING OFFICE: 1981-703029/1255

By Order of the Secretary of the Army:

Official:

ROBERT M. JOYCE  
*Brigadier General, United States Army*  
*The Adjutant General*

E. C. MEYER  
*General, United States Army*  
*Chief of Staff*

DISTRIBUTION:

To be distributed in accordance with Special List.



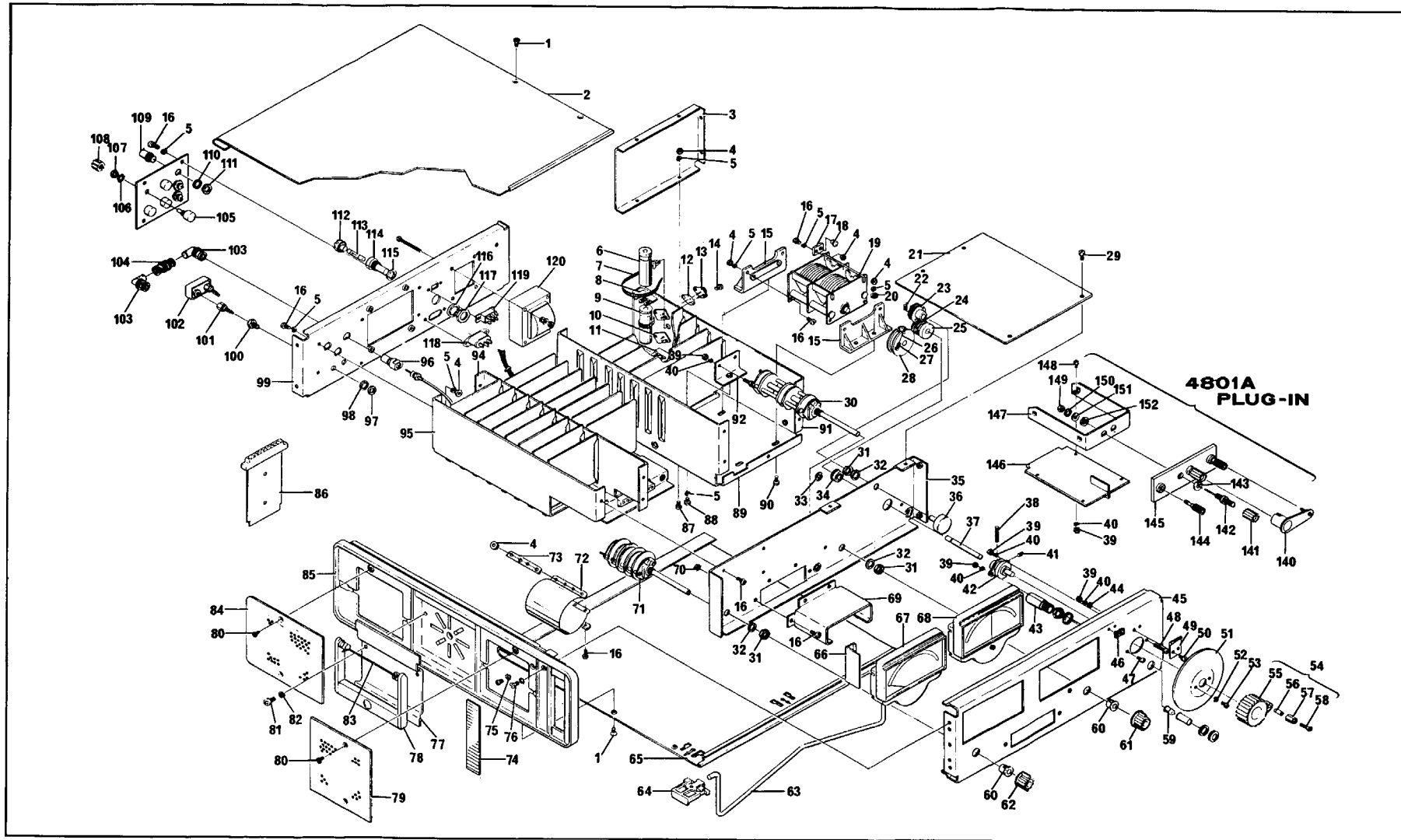
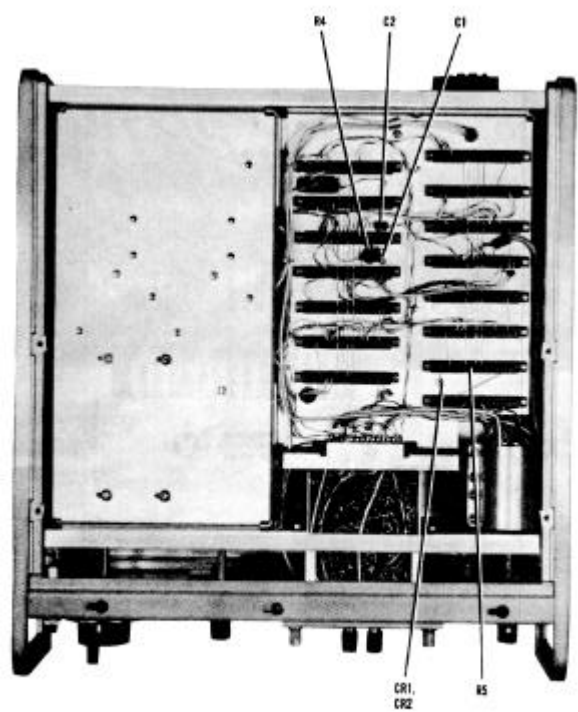

Figure 6-1. 4800A VECTOR IMPEDANCE METER



BOTTOM VIEW

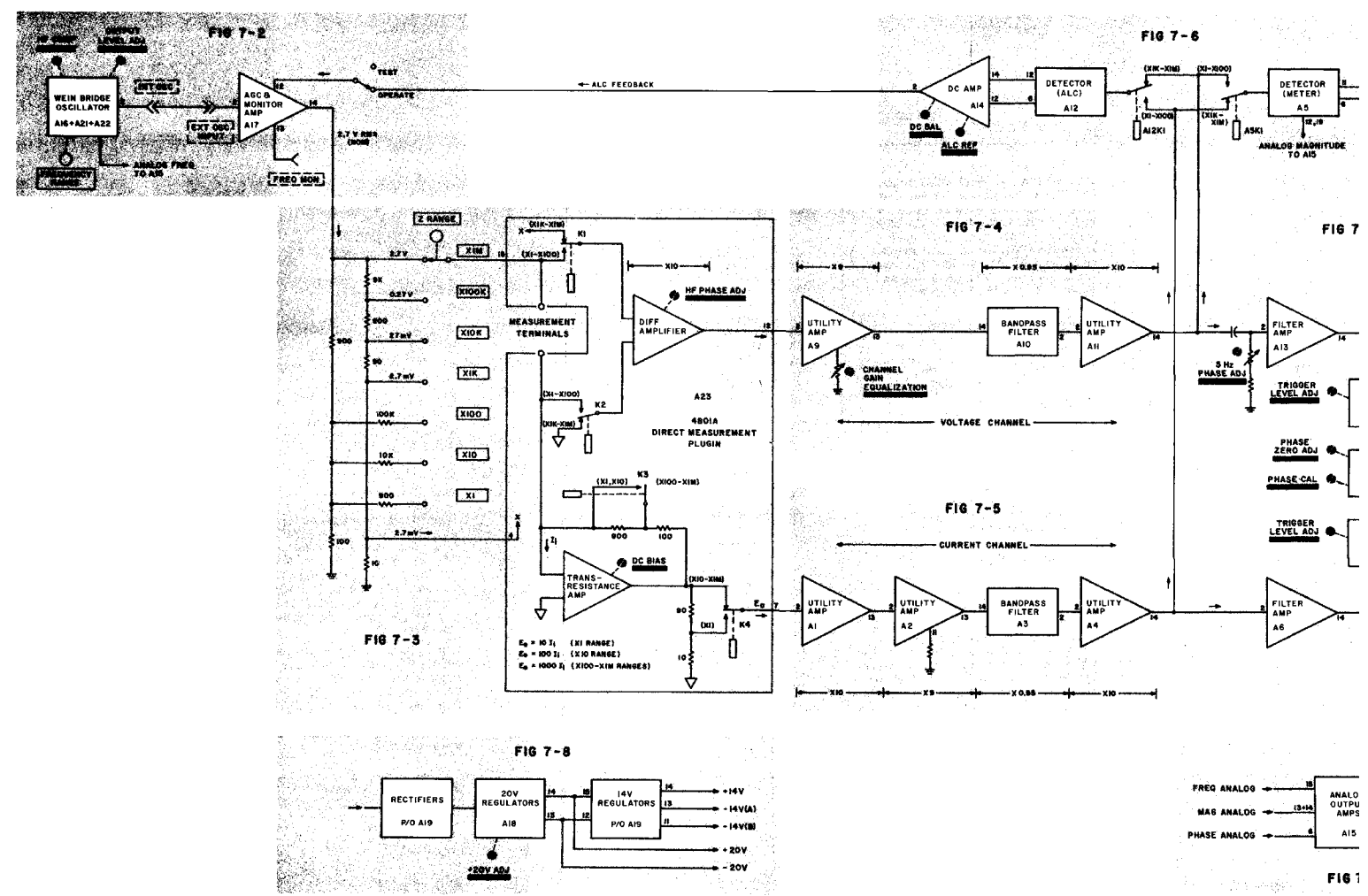
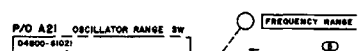
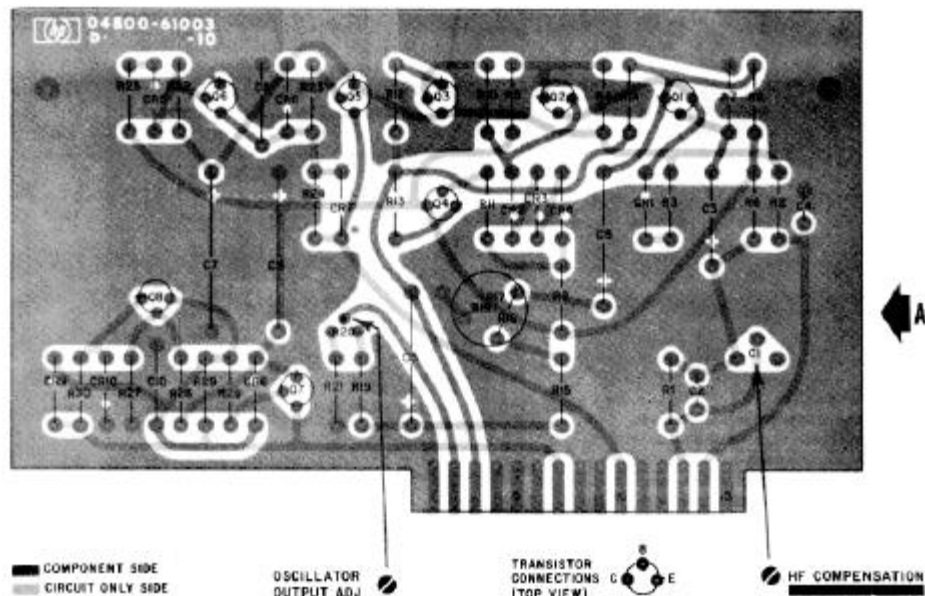
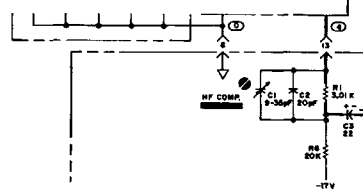

Figure 7-1. FUNCTIONAL BLOCK DIAGRAM



To obtain a low frequency limit of 5 Hz with a practical sized tuning capacitors, resistance in the frequency selective network must be high - 50 MΩ in the 4800A. The high input impedance of an FET source follower (A22Q1) minimizes amplifier loading. All possible leakage paths from the FET gate to ground must be very high resistance.



Oscillator circuits are decoupled from the +20 V supplies through +17 V regulators which perform as active filters.

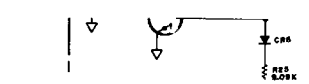

The regulator pass transistor, Q5 (Q7), is protected against failure (short circuits) of +20 V (-20 V) by CR6 (CR8) which prevents emitter-base reverse breakage and by CR7 (CR9) which prevents damage caused by a forward bias of the collector-base junction. The protection is against large current pulses that develop due to the discharge of capacitors in the regulator load.

The test signal oscillator is a resistance-capacitance type (Wein bridge). The circuit consists of a feedback amplifier having both positive and negative feedback loops. The positive loop includes the R-C frequency selective network and causes the circuit to oscillate. Resistance is selected by the FREQUENCY RANGE (Hz) switch and capacitance by the setting of the FREQUENCY tuning capacitor (A22C1A/B).

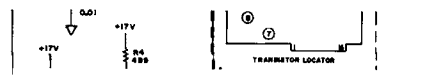

Phase shift which occurs near the high and low frequency extremes causes errors in dial calibration. Low frequency phase shift caused by C5 and C6 in the feedback path is compensated by the network C3 and R7. High frequency phase shift caused by delay through the amplifier is compensated by C1-C2 and R1. A16C1 is adjusted for dial calibration at a high frequency point (159.2 kHz).

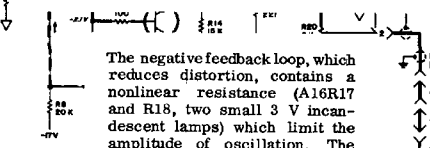

The negative feedback loop, which reduces distortion, contains a nonlinear resistance (A16R17 and R18, two small 3 V incandescent lamps) which limit the amplitude of oscillation. The lamps, with positive temperature coefficients, adjust their resistance higher or lower to compensate for any tendency of the oscillations to vary in amplitude. Because lamp characteristics vary widely, output amplitude is normalized to 0.8 V, approximately, before being applied to following circuits. Output level changes due to ambient temperature changes, are reduced by R16, a tungsten filament resistor (positive temperature coefficient) of approximately 100 ohms.

REFERENCE DESIGNATIONS				
A16	A17	A21	A22	CHANGE
C1-10	C1-8	R1-10	C1-3	CP 1-3
CR 1-10	CR1-8	R1	Q1	J1,6,7
R1	DS1	Q1	R1	R1
Q1-8	Q1	R1	R1	R1
R1-20	L1,2	R1-23	R1	R1
		V1		

DELETED: A17R15, A17R14, A17R16, R1 (C68818)

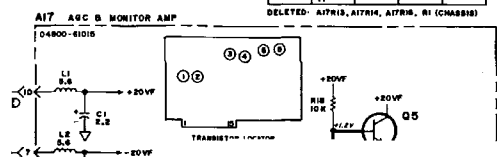

Complementary emitter followers Q5 and Q6 decouple the AGC amplifier output from external monitoring equipment.

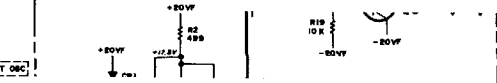

Amplifier stage Q1-Q4 comprise a feedback stabilized amplifier. One element of the negative feedback path is V1/DS1, a photocell lamp modulator. Lamp current is supplied as leveling feedback from DC Amplifier, A14. As lamp current is increased, photocell resistance decreases; the resulting decrease in feedback causes an increase in output voltage.

The amplifier is the controlled element in the overall leveling loop that supplies the measurement terminals with a constant test current (or voltage) depending on Z MAGNITUDE switch position. Complementary emitter followers are used to give low impedance.

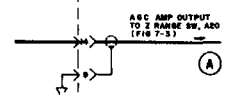

S1 permits breaking of the leveling loop for troubleshooting purposes. In the TEST position there is no current through DS1; V1 resistance is very high, resulting in total feedback around the Q1-4 amplifier and thus a gain of unity.

Figure 7-1. FUNCTIONAL BLOCK PROGRAM

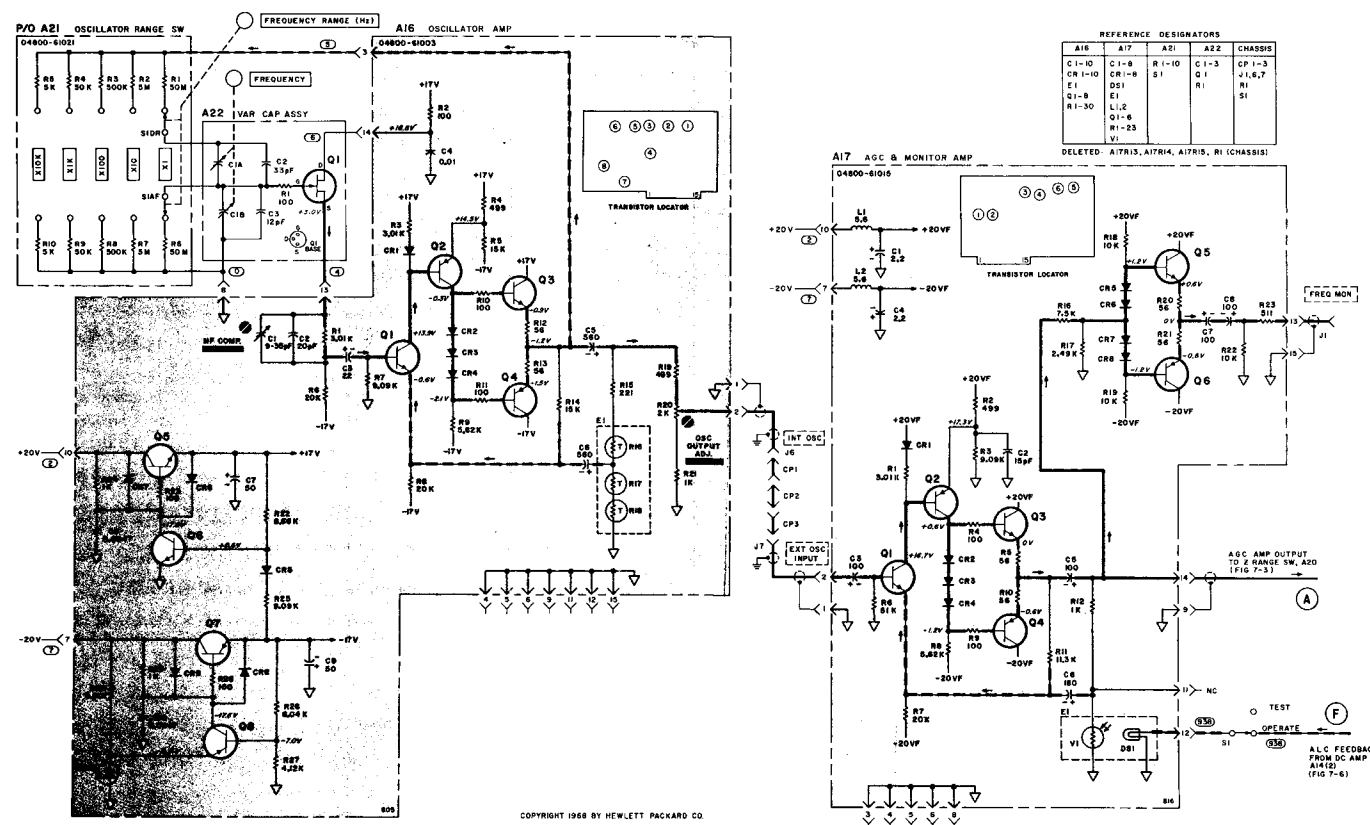
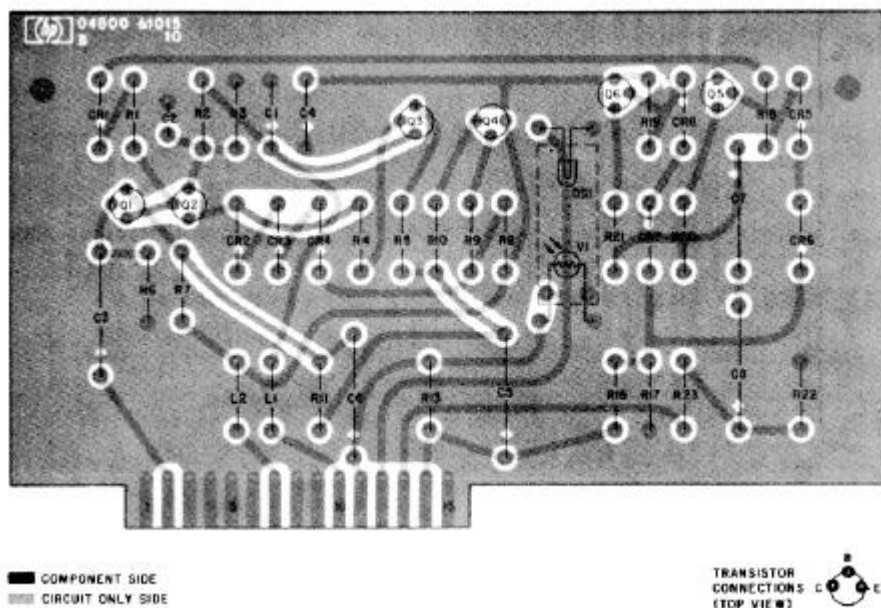

Figure 7-2. OSCILLATOR-AGC AMPLIFIER

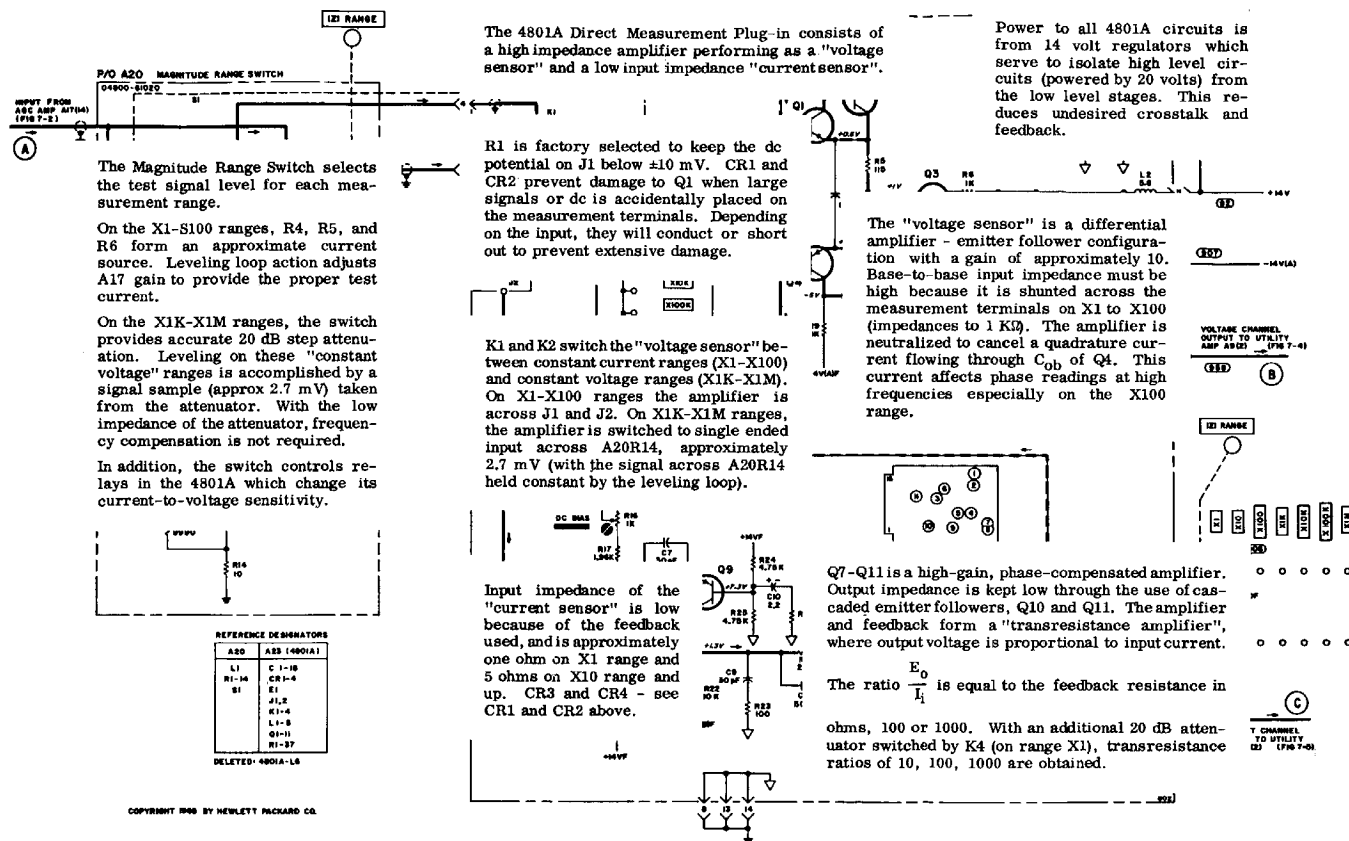
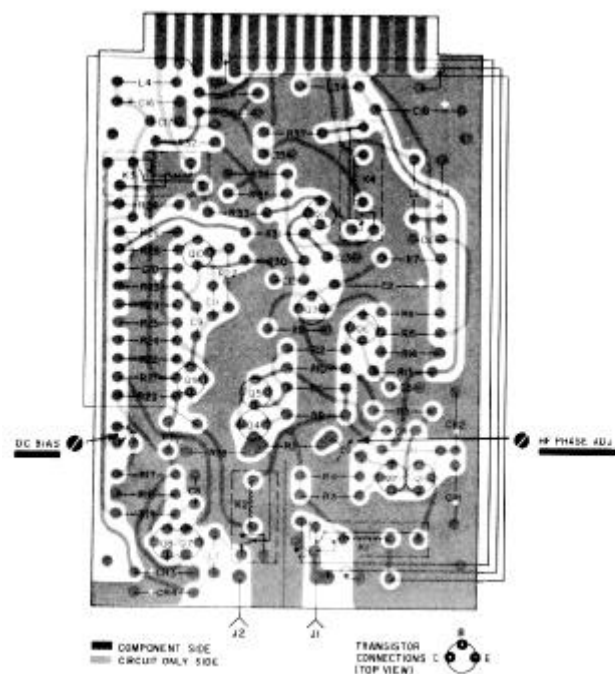

Figure 7-2.  
OSCILLATOR-AGC AMPLIFIER  
7-5

7-6

Figure 7-2. OSCILLATOR-AGC AMPLIFIER



A23

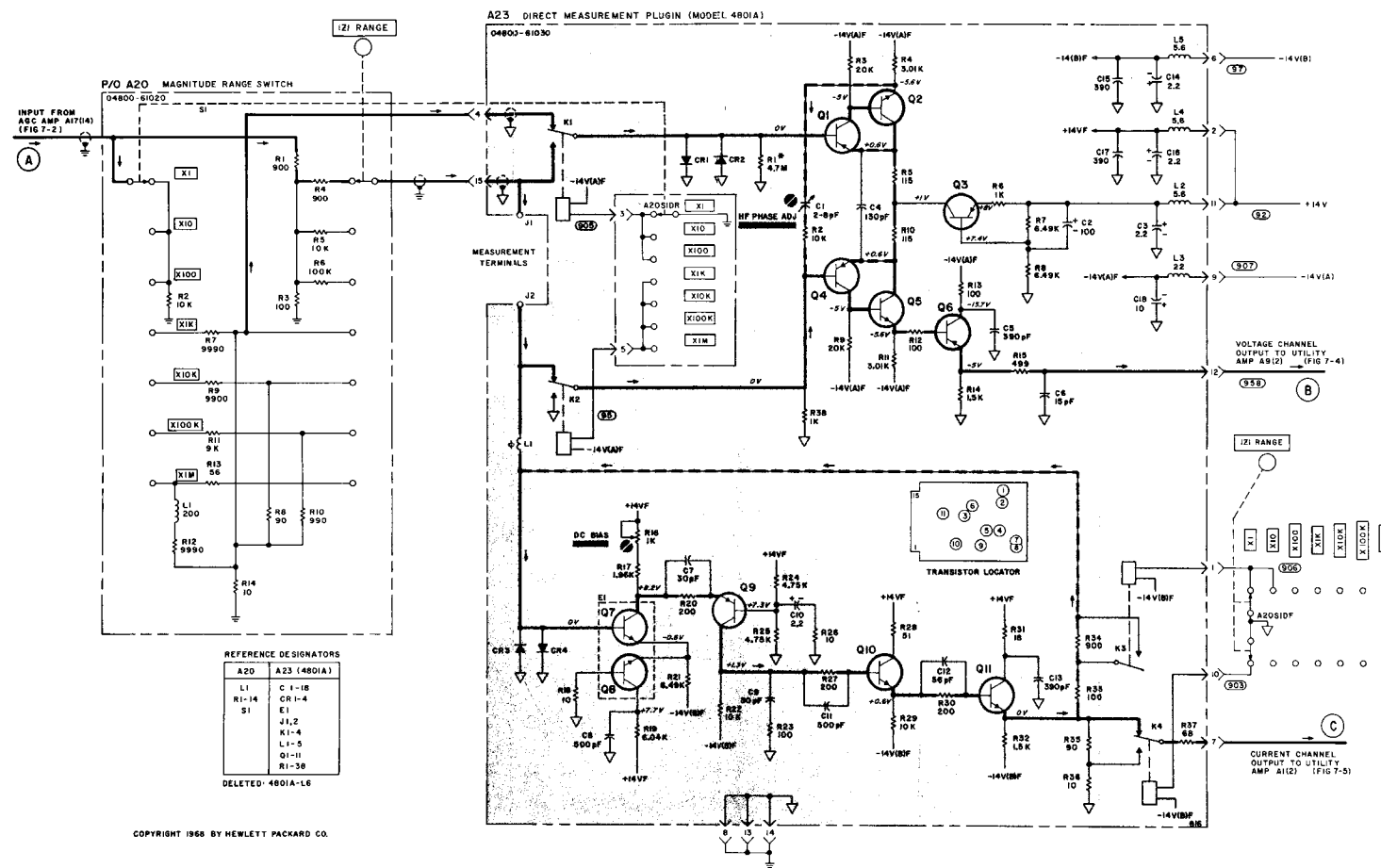
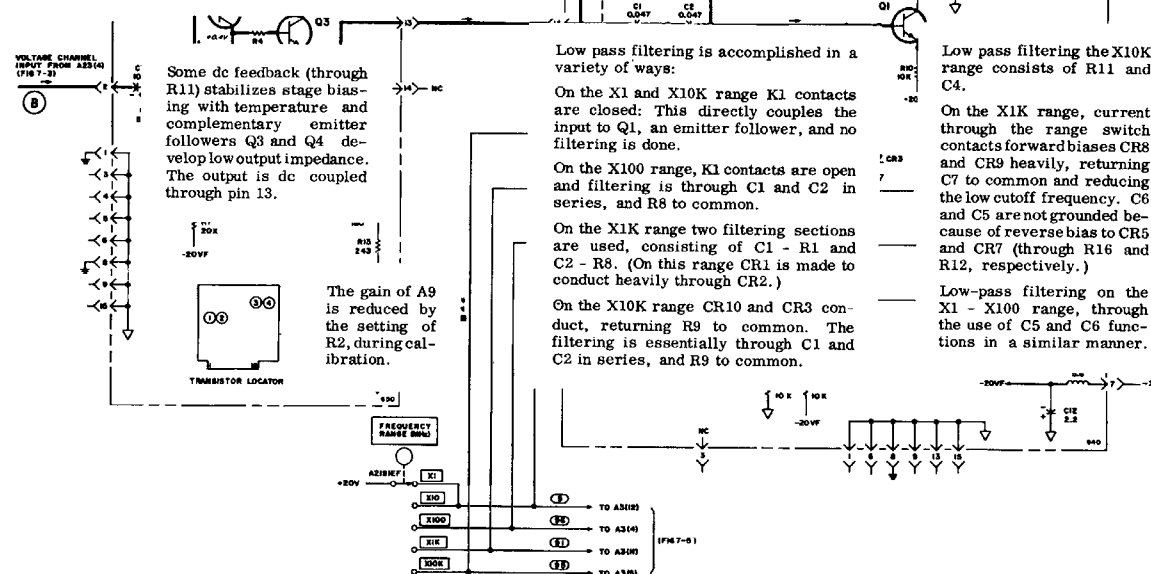

Figure 7-3. Z RANGE SWITCHING & 4801A DIRECT MEASUREMENT PLUG-IN

The Utility Amplifier is a feedback stabilized amplifier. The feedback path is only partially on the circuit board - an external connection is required. If the external connection is a short between pins 11 and 12, the amplifier gain is 10. If a resistor is connected between pins 11 and 12, the gain will be less than 10 and depend on the resistor value.

Bandpass filter A10 reduces the effect of signal pickup on leads used to connect networks to the 4801A measurement terminals.

Low and high pass filtering is switched with a relay and a series of diode switches controlled by the FREQUENCY RANGE switch setting.



Some dc feedback (through R11) stabilizes stage biasing with temperature and complementary emitter followers Q3 and Q4 develop low output impedance. The output is dc coupled through pin 13.

The gain of A9 is reduced by the setting of R2, during calibration.

Low pass filtering is accomplished in a variety of ways:

On the X1 and X10K range K1 contacts are closed: This directly couples the input to Q1, an emitter follower, and no filtering is done.

On the X100 range, K1 contacts are open and filtering is through C1 and C2 in series, and R8 to common.

On the X1K range two filtering sections are used, consisting of C1 - R1 and C2 - R8. (On this range CR1 is made to conduct heavily through CR2.)

On the X10K range CR10 and CR3 conduct, returning R9 to common. The filtering is essentially through C1 and C2 in series, and R9 to common.

Low pass filtering the X10K range consists of R11 and C4.

On the X1K range, current through the range switch contacts forward biases CR8 and CR9 heavily, returning C7 to common and reducing the low cutoff frequency. C6 and C5 are not grounded because of reverse bias to CR5 and CR7 (through R16 and R12, respectively.)

Low-pass filtering on the X1 - X100 range, through the use of C5 and C6 functions in a similar manner.

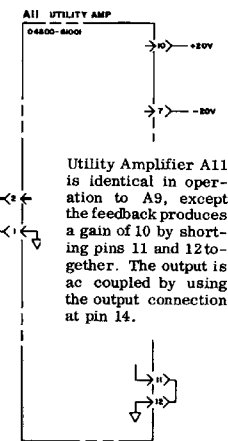

Utility Amplifier A11 is identical in operation to A9, except the feedback produces a gain of 10 by shorting pins 11 and 12 together. The output is ac coupled by using the output connection at pin 14.

AP, R	A10	A11	CHANGE
C1-8	C1-10	B1E7	RE
CR1-6	CR1-10		
L1,2	L1		
Q1-4	Q1		
R1-13	R1-25		

COPYRIGHT 1968 BY HEWLETT PACKARD CO.

Figure 7-3.  
Z RANGE SWITCHING & 4801A  
DIRECT MEASUREMENT PLUG-IN

Figure 7-3. Z RANGE SWITCHING & 4801A DIRECT MEASUREMENT PLUG IN

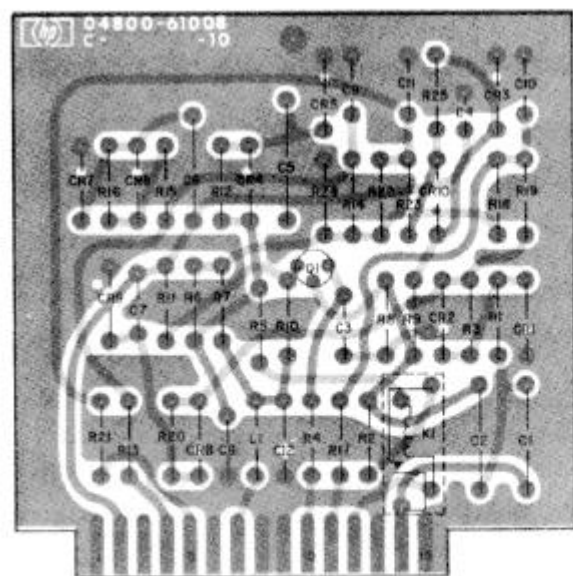

COMPONENT SIDE  
 CIRCUIT ONLY SIDE

TRANSISTOR CONNECTIONS (TOP VIEW)

A10

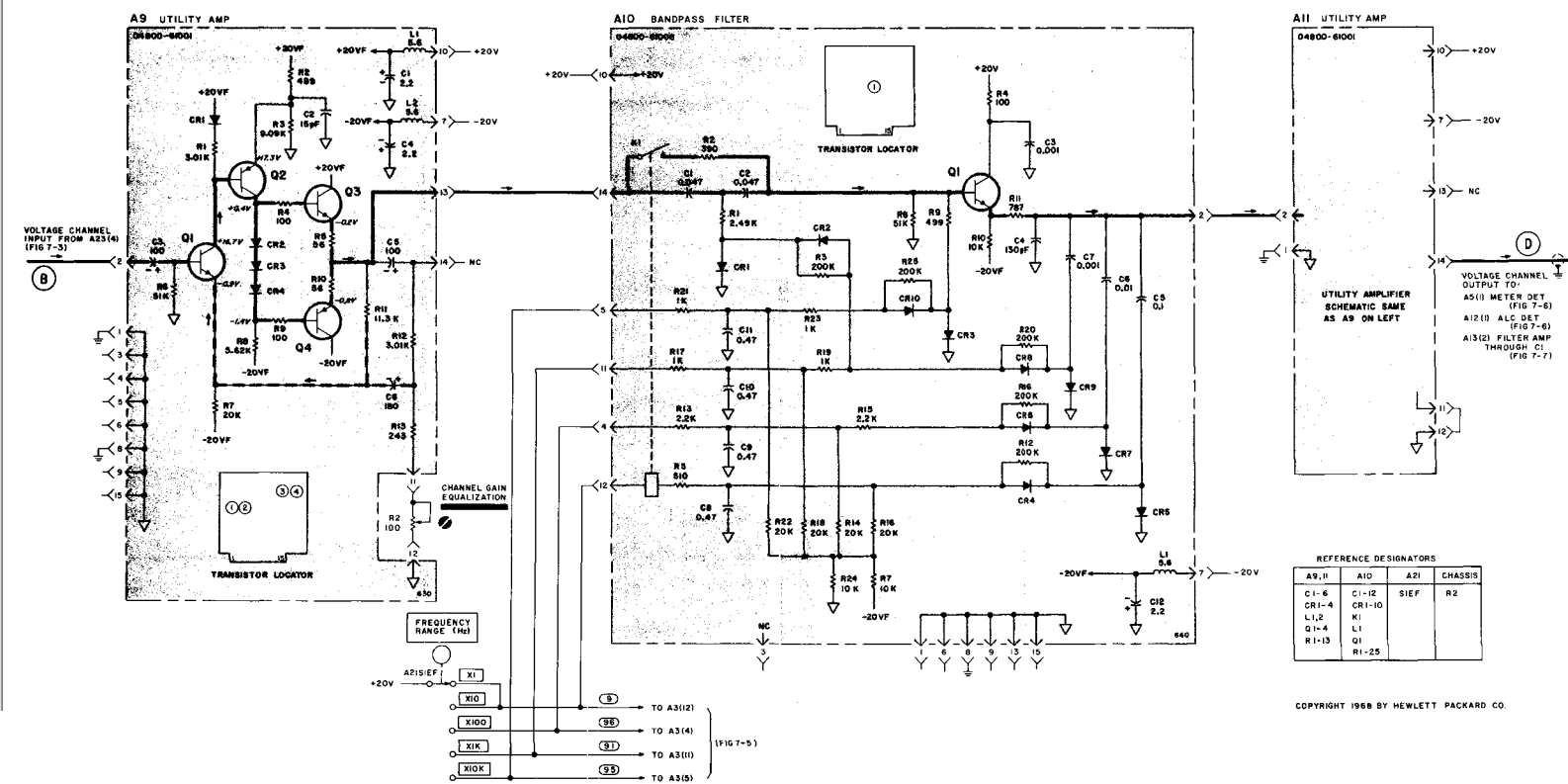

REFERENCE DESIGNATORS

A9, 11	A10	A21	CHASSIS
C1-6	C1-12	S1E1	R2
CR1-4	CR1-10		
L1,2	L1		
Q1-4	Q1		
R1-13	R1-25		

COPYRIGHT 1968 BY HEWLETT PACKARD CO.

Figure 7-4. VOLTAGE CHANNEL AMPLIFIERS



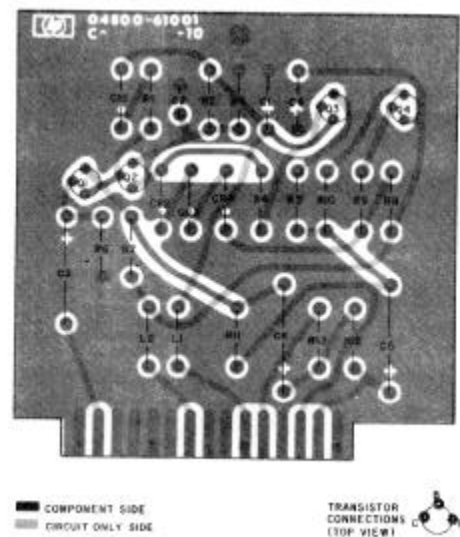

← A1,A2,A4

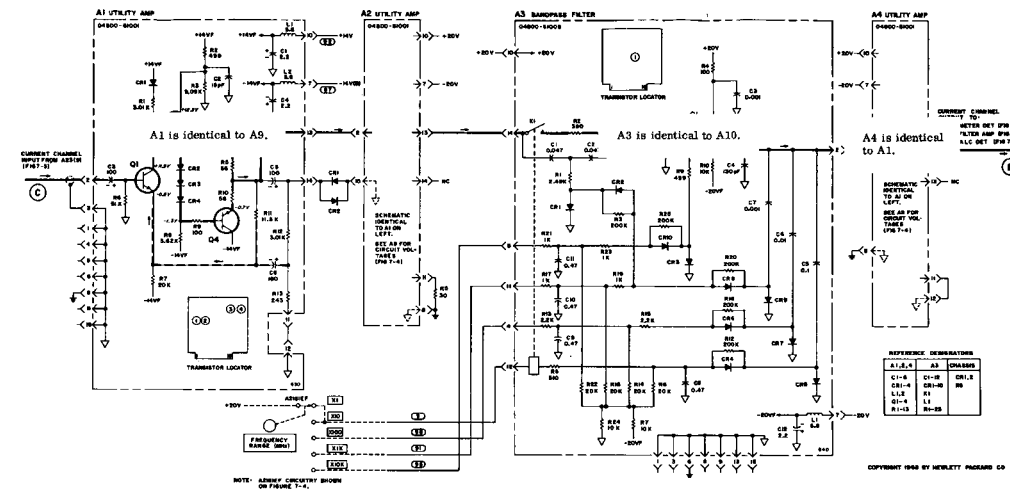
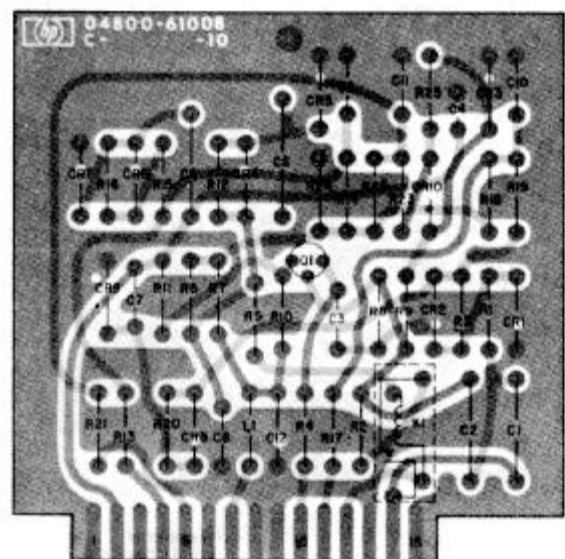

Figure 7-4.  
VOLTAGE CHANNEL AMPLIFIERS  
7-9

7-10

Figure 7-4. VOLTAGE CHANNEL AMPLIFIERS



COMPONENT SIDE  
CIRCUIT ONLY SIDE

TRANSISTOR CONNECTIONS (TOP VIEW)

A3

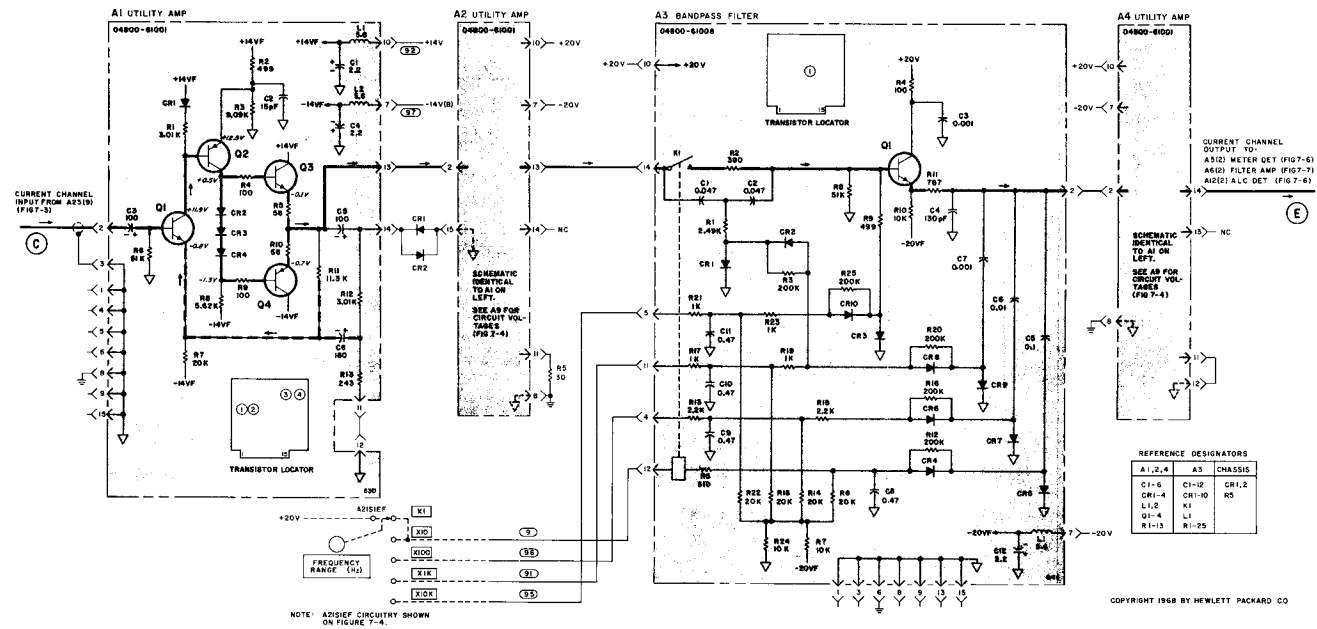
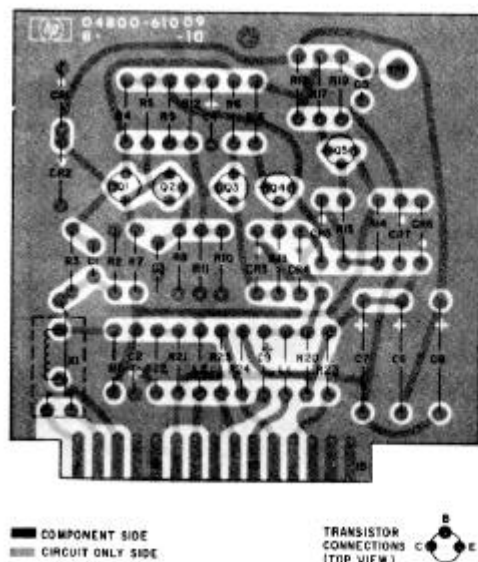
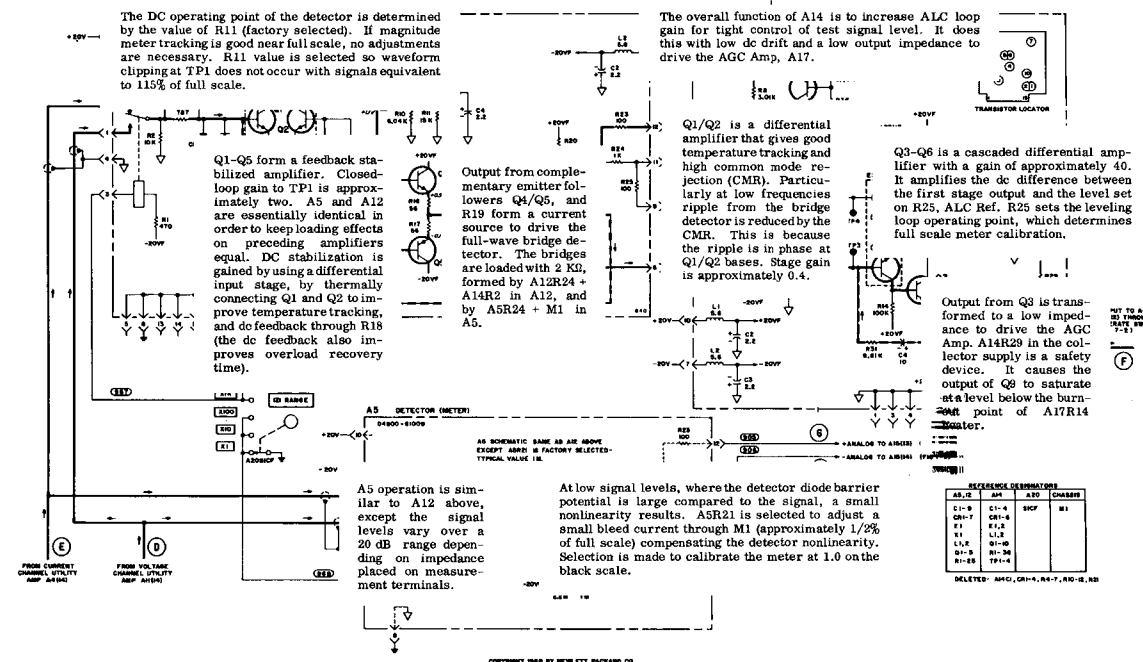

Figure 7-5. CURRENT CHANNEL AMPLIFIERS



← A5, A12



← Figure 7-5. CURRENT CHANNEL AMPLIFIERS 7-11

7-12

Figure 7-5. CURRENT CHANNEL AMPLIFIERS

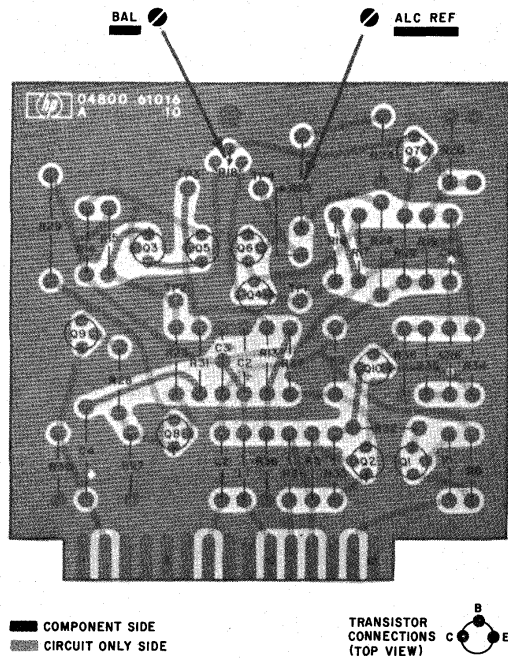

A14

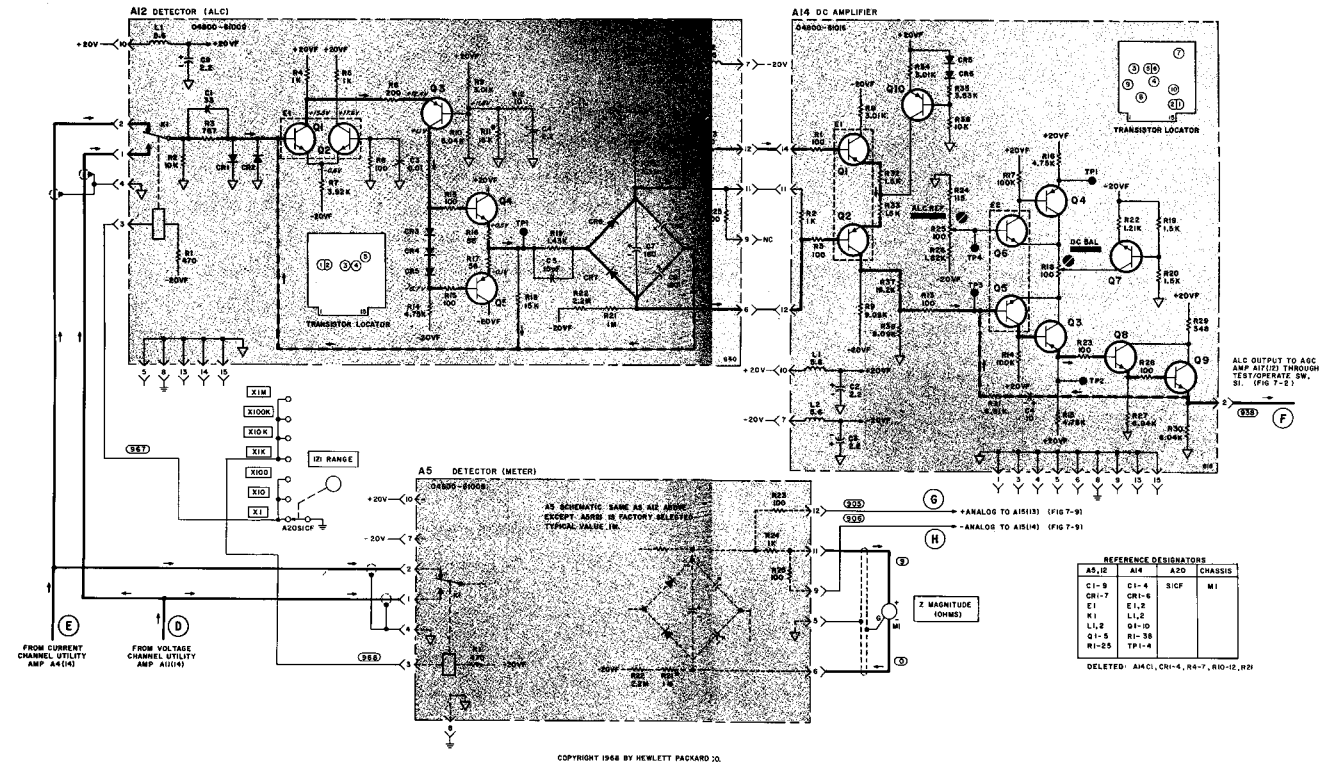
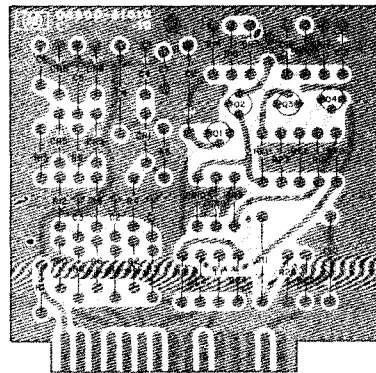
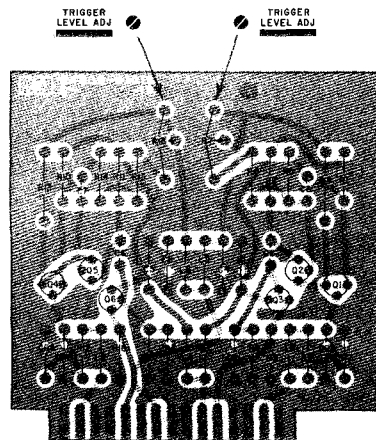

Figure 7-6. DETECTORS AND DC AMPLIFIER



COMPONENT SIDE  
CIRCUIT ONLY SIDE

TRANSISTOR CONNECTIONS (TOP VIEW)



← A6, A13

← A7

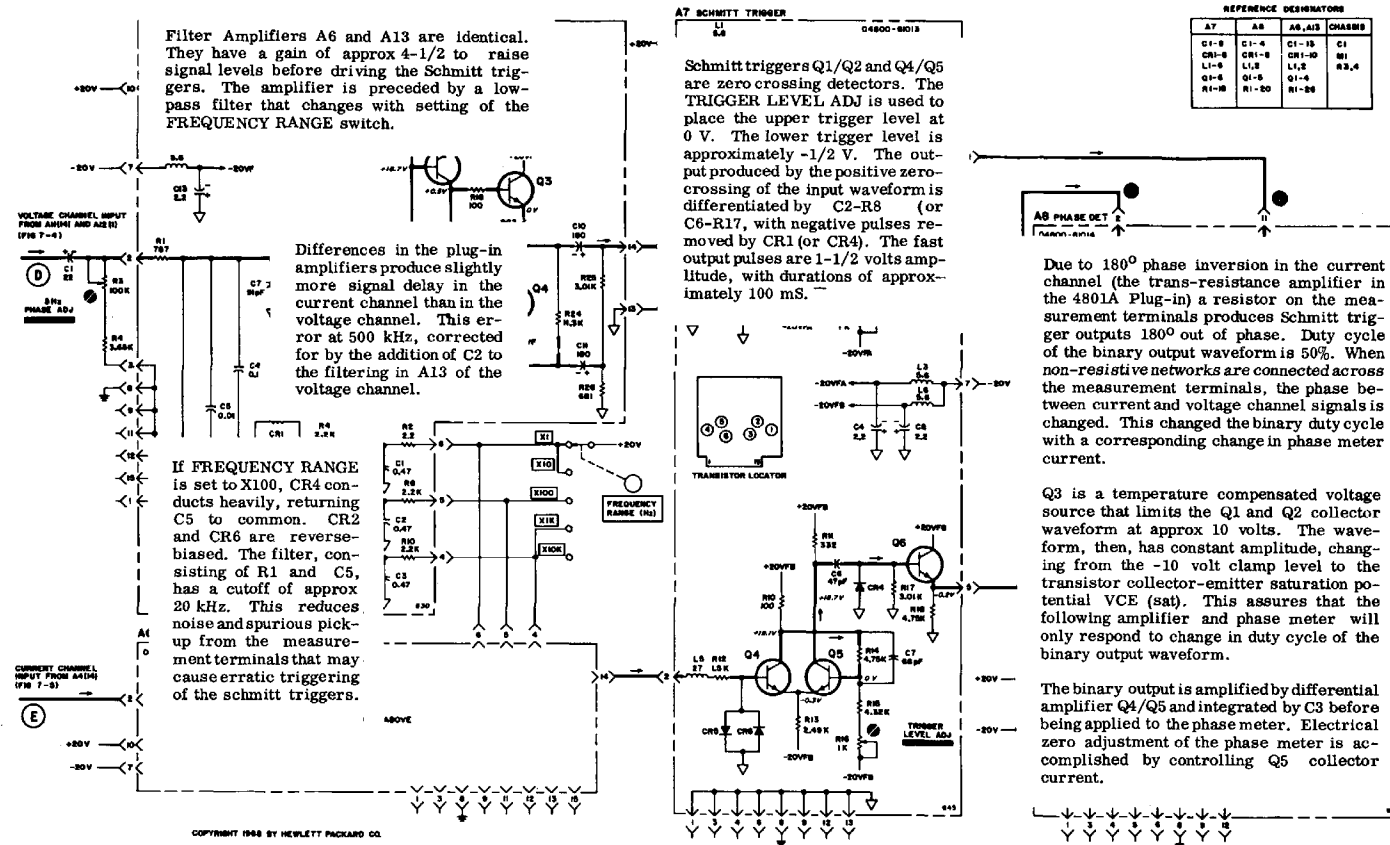
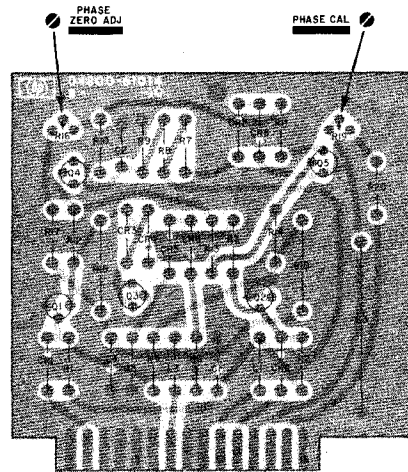

Figure 7-8. DETECTORS AND DC AMPLIFIER



COMPONENT SIDE  
CIRCUIT ONLY SIDE

TRANSISTOR CONNECTIONS C (TOP VIEW)

**WAVEFORMS**  
**NOTE**  
Refer to Troubleshooting Tree #4 for information on waveforms.

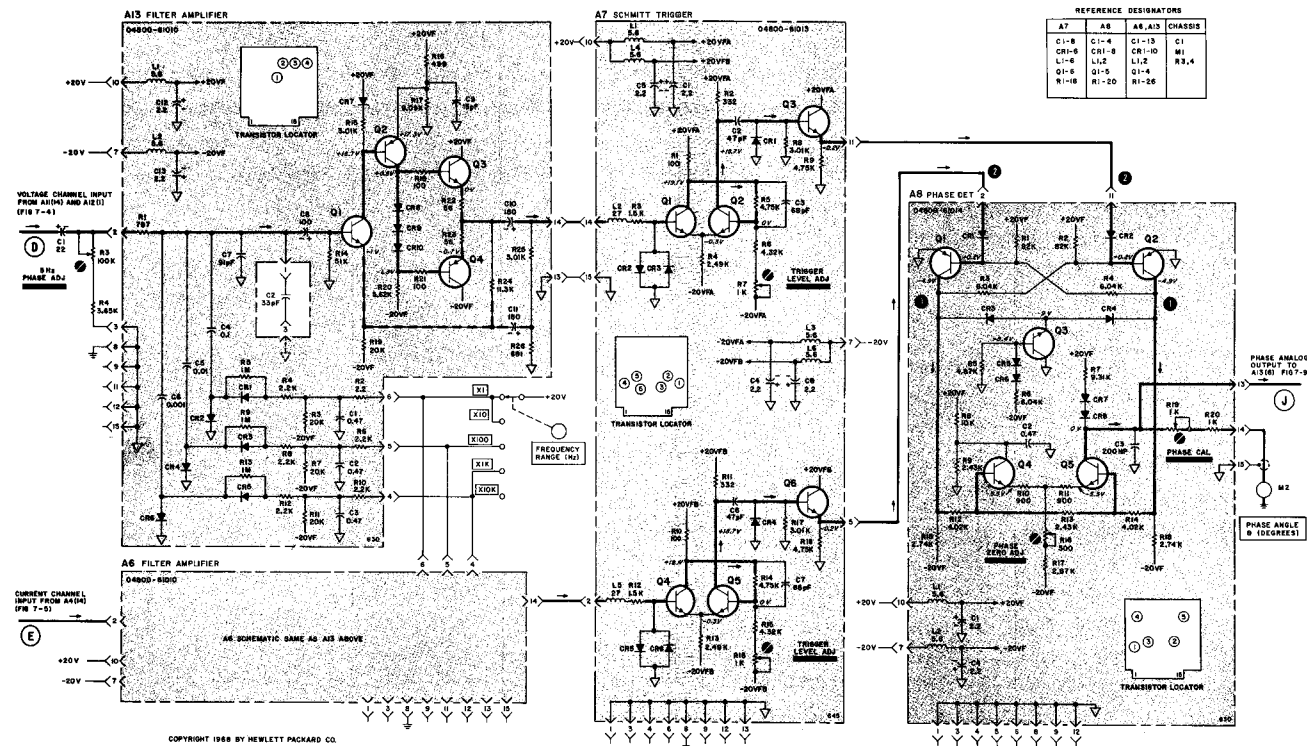
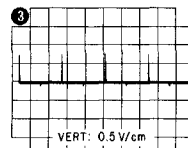
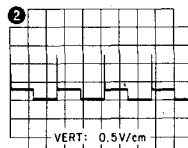
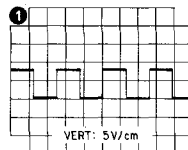

Figure 7-7. PHASE MEASUREMENT CIRCUITS

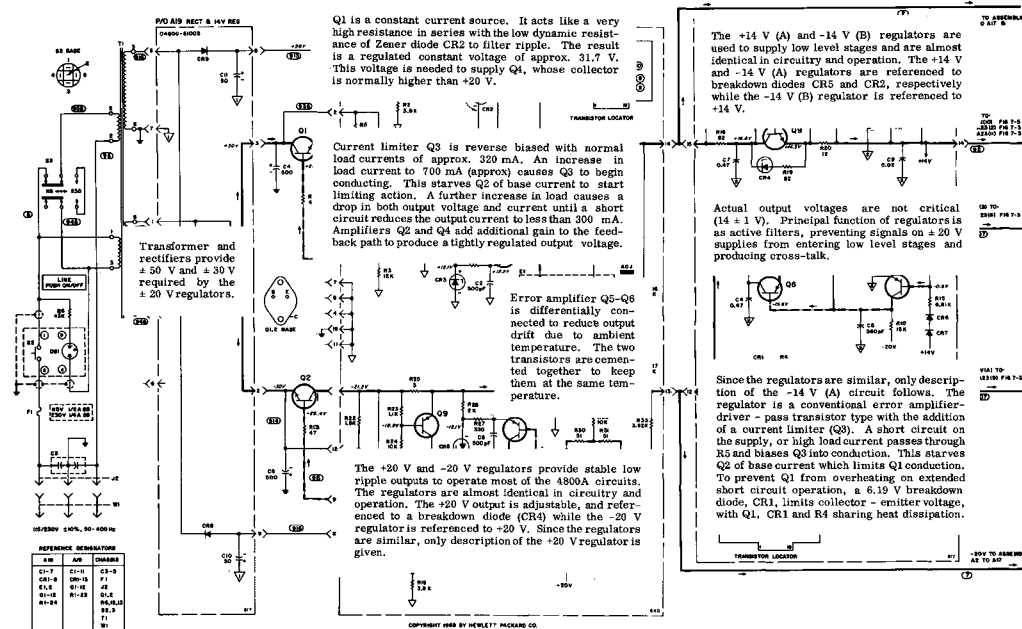
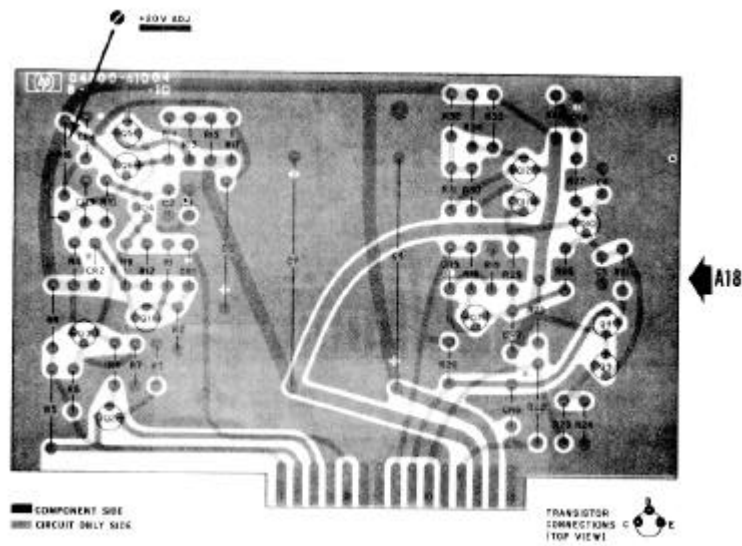
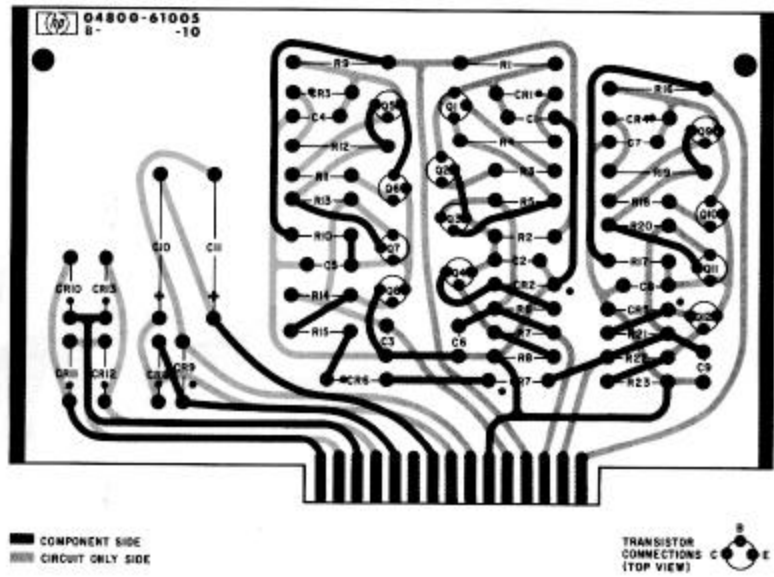

Figure 7-7. PHASE MEASUREMENT CIRCUITS 7-15

7-16

Figure 7-7. PHASE MEASUREMENT CIRCUITS



← A19

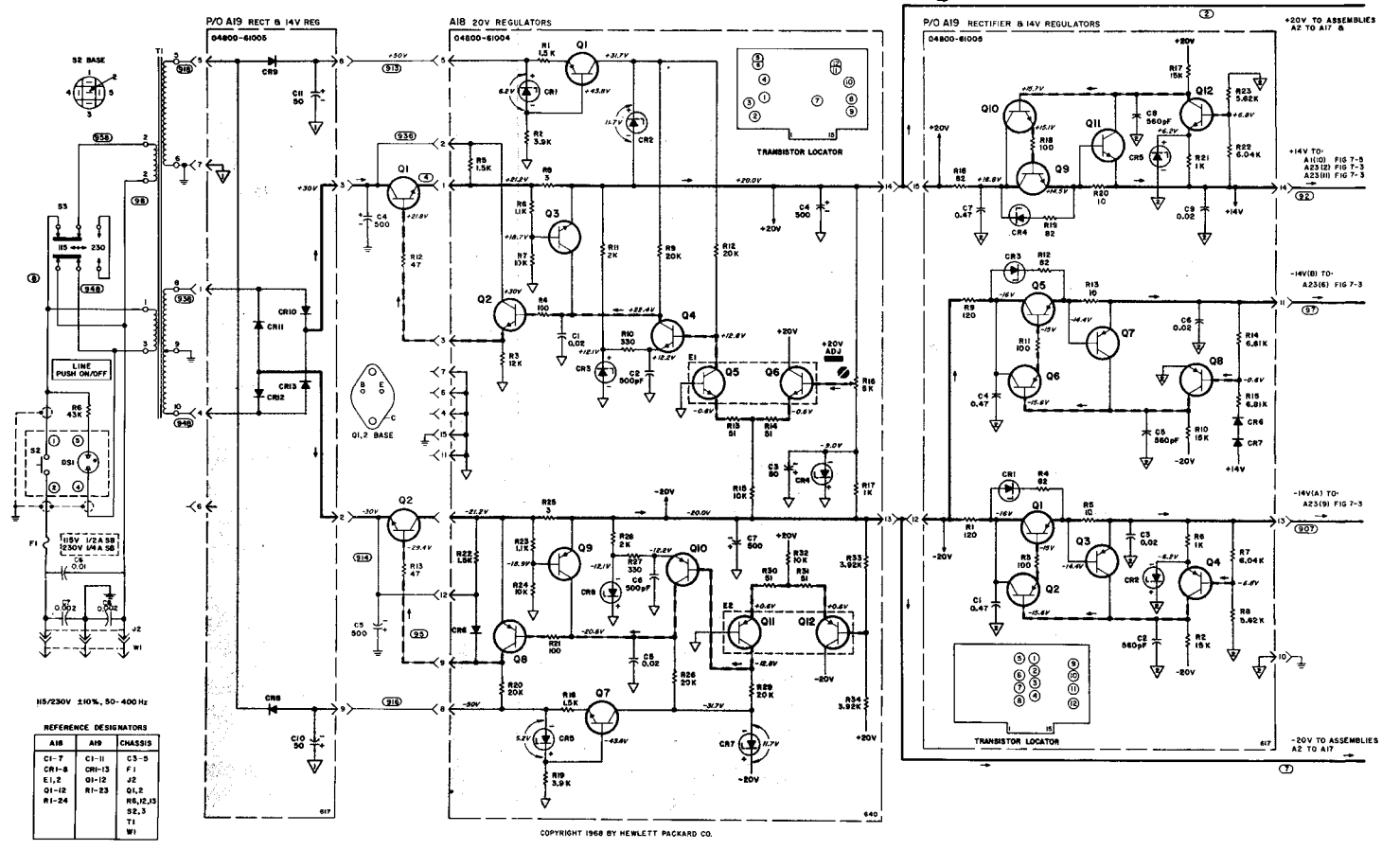

Figure 7-8. POWER SUPPLIES



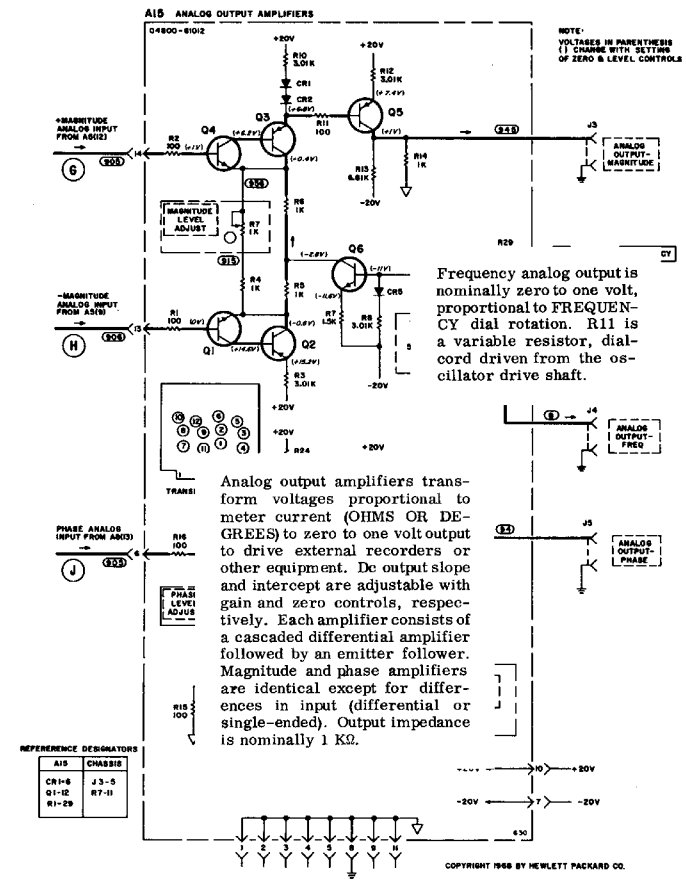
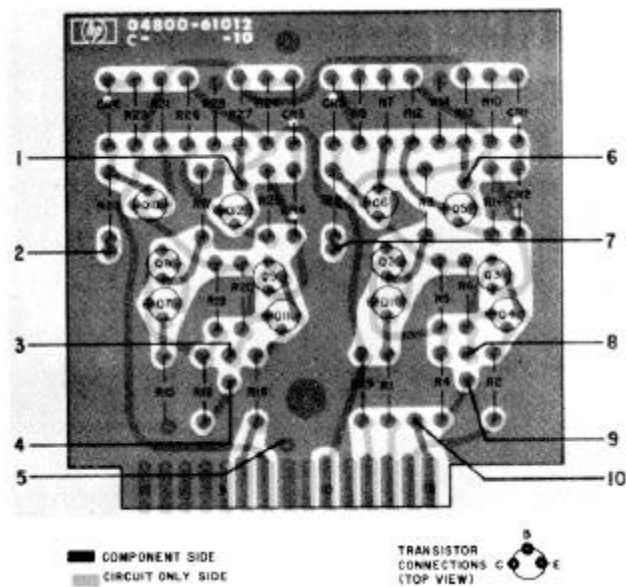

Figure 7-8. POWER SUPPLIES  
7-17



← A15

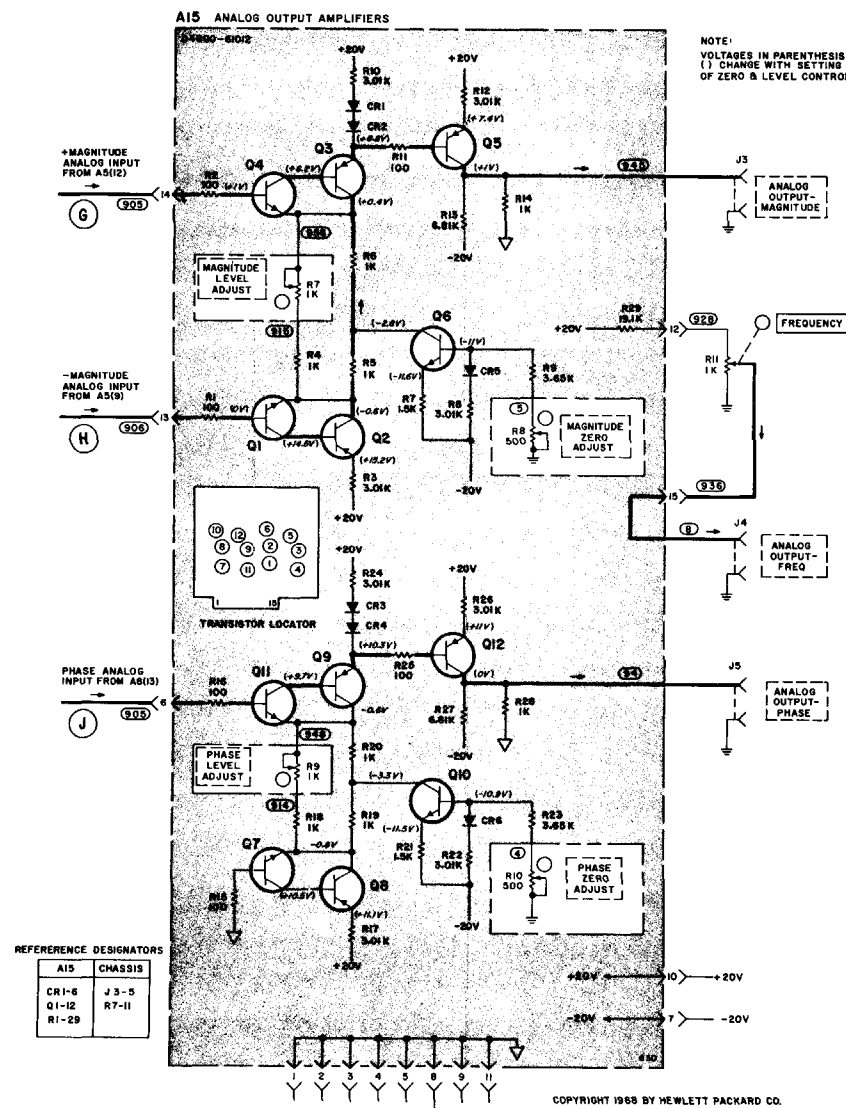



Figure 7-9. ANALOG OUTPUTS

RECOMMENDED CHANGES TO EQUIPMENT TECHNICAL PUBLICATIONS



THEN... JOT DOWN THE DOPE ABOUT IT ON THIS FORM, CAREFULLY TEAR IT OUT, FOLD IT AND DROP IT IN THE MAIL!

## SOMETHING WRONG WITH THIS PUBLICATION?

FROM: (PRINT YOUR UNIT'S COMPLETE ADDRESS)

DATE SENT

PUBLICATION NUMBER

PUBLICATION DATE

PUBLICATION TITLE

BE EXACT... PIN-POINT WHERE IT IS				IN THIS SPACE TELL WHAT IS WRONG AND WHAT SHOULD BE DONE ABOUT IT:
PAGE NO.	PARA-GRAPH	FIGURE NO.	TABLE NO.	

PRINTED NAME, GRADE OR TITLE, AND TELEPHONE NUMBER

SIGN HERE:

TEAR ALONG PERFORATED LINE

DA FORM 2028-2  
1 JUL 78

PREVIOUS EDITIONS ARE OBSOLETE.

P.S.—IF YOUR OUTFIT WANTS TO KNOW ABOUT YOUR RECOMMENDATION MAKE A CARBON COPY OF THIS AND GIVE IT TO YOUR HEADQUARTERS.

