

DEPARTMENT OF THE ARMY TECHNICAL MANUAL

ORGANIZATIONAL MAINTENANCE MANUAL

TRUCK, FIRE FIGHTING: POWERED

PUMPER; FOAM AND WATER,

500 G.M.P. CAP.; CENTRIFUGAL

PUMP, POWER TAKE OFF DRIVEN;

400 GAL. WATER TANK, 40 GAL.

FOAM CHEMICAL TANK

(WARD LAFRANCE MODEL M44A1WLF)

FSN 4210-225-9127

HEADQUARTERS, DEPARTMENT OF THE ARMY
11 DECEMBER 1964

SAFETY PRECAUTIONS

BEFORE OPERATION

Do not smoke or use open flame in the area when servicing the batteries. Batteries generate hydrogen, a highly explosive gas.

Keep metal decks free from grease, oil, and mud, to avoid possible injury.

When handling gasoline always provide a good metal-to-metal contact between fuel tank and container.

DURING OPERATION

When water is being pumped through the discharge system, at least two men should control the hose at the nozzle to prevent the hose from whipping and causing serious injury.

Stop all operation before performing service adjustments.

Use of a nozzle too small for the pressure can rupture the hose.

AFTER OPERATION

When handling gasoline always provide a good metal-to-metal contact between fuel tank and container.

Do not remove radiator cap from a hot engine until engine has been shut down for 5 minutes to relieve pressure and avoid being burned.

CHANGE

No. 3

HEADQUARTERS
DEPARTMENT OF THE ARMY
Washington N, D. C., 16 July 1973

**Operator and Organizational Maintenance Manual
TRUCK, FIRE FIGHTING: POWERED PUMPER;
FOAM AND WATER, 500-GPM; CENTRIFUGAL PUMP,
POWER TAKE-OFF DRIVEN; 400 GAL WATER TANK, 40
GAL FOAM CHEMICAL TANK (WARD LAFRANCE MODEL
M44A1WLF) NON-WINTERIZED FSN 4210-225-9127
(WARD LAFRANCE MODEL M44A1WLF-W)
WINTERIZED FSN 4210-965-1306**

TM 5-4210-205-12, 11 December 1964, is changed as follows:

Page 1. Appendix III Title is changed as follows: "Basic Issue Items List and Items Troop Installed or Authorized."

Page 2. Paragraph 1d is changed as follows:

"d. Reports of errors, omissions, and recommendations for improving this publication by the individual user is encouraged. Reports

should be submitted on DA Form 2028 (Recommended Changes to DA Publications) and forwarded direct to Commanding General, U.S.

Army Troop Support Command, ATTN:
AMSTS-MPP, 4300 Goodfellow Blvd., St. Louis, MO. 63120.

Page 7. After paragraph 8d(5) add "e. For Maintenance and Operating Supplies see Table 1."

Table 1.1. Maintenance and Operating Supplies

(1) Component Application	(2) Federal Stock Number	(3) Description	(4) Quantity Required F/ Initial Operation	(5) Quantity Required F/8 Hours Operation	(6) Notes
PUMP ASSEMBLY	915-231 (1)	OIL, LUBRICATING: 5- gal pail as follows: Grade 9250 or	2 qt	(2)	(1) S" SM 10-C-100-Se for additional data and requisitioning procedure
	9130-265-9435 (1)	OE-30	2 qt	(2)	(2) See current LO for grade application and replacement intervals
	9150-231-0937 (1)	Grade 9110 or	2 qt	(3)	
	9150-265-9428 (1)	OE-10	2 qt	(2)	(3)Use oil as prescribed for pump assembly above
	9150-242-7601 (1)	OES	2 qt	(2)	
GREASE POINTS	9150-190-0904	GREASE, AUTOMOTIVE AND ARTILLERY: 1lb. can as follows: GAA OIL LUBRICATING (3)	as reqr 6 qt	(2) (2)	
TANK PRIM-ING PUYP					

*This change supersedes C2, 7 April 1969

THIS PUBLICATION IS A COURTESY QUICK COPY FROM THE UNITED STATES ARMY PUBLICATIONS DISTRIBUTION CENTER, ST. LOUIS, MISSOURI, TO MEET YOUR NEEDS WHILE WE REPLENISH OUR REGULAR STOCK.

**APPENDIX III
BASIC ISSUE ITEM LIST AND ITEMS
TROOP INSTALLED OR AUTHORIZED**

Section I. INTRODUCTION

1. Scope

This appendix lists basic issue items, items troop installed or authorized which accompany the fire truck and are required by the crew/ operator for operation, installation, or operator's maintenance.

2. General

This basic issue items, items troop installed or t authorized list is divided into the following sections:

a. Basic Issue Items List Section II. Not applicable.

b. Items Troop Installed or Authorized List -Section III. A list in alphabetical sequence of items which at the discretion of the unit commander may accompany the end item, but are NOT subject to be turned in with the end item.

3. Explanation of Columns

The following provides an explanation of col

umn in the tabular list of Basic Issue Items List, Section II, and Items Troop Installed or Authorized, Section m.

a. Source, Maintenance, and Recoverability Code(s) (SMR): Not applicable.

b. Federal Stock Number. This column indicates the Federal stock number assigned to the item and will be used for requisitioning purposes.

c. Description This column indicates the Federal item name and any additional description of the item required.

d. Unit of Measure (U/M). A character alphabetic abbreviation indicating the amount or quantity of the item upon which the allowances are based, e.g., ft, ea, pr, etc.

e. Quantity Authorized (Items Troop Installed or Authorized Only). This column indicates the quantity of the item authorized to be used with the equipment.

Section III. ITEMS TROOP INSTALLED OR AUTHORIZED LIST

(1) SMR Code	(2) Federal Stock Number	(3) Description Ref. No. & Mfr Code	Usable On Code	(4) Unit of Meas	(5) Qty Auth
	5140-777-4142	BAG, TOOL SATCHEL		EA	1
	4910-204-2547	GAGE, INFLATOR		EA	1
	4720-092-9264	HOSE ASSEMBLY, RUBBER		EA	1
	5120-223-7398	PLIERS, SLIP JOINT		EA	1
	2520-222-8852	SCREWDRIVER		EA	1
	5120-234-9913	SCREWDRIVER		EA	1
	5120-240-8716	SCREWDRIVER		EA	1
	5120-449-8063	WRENCH, ADJUSTABLE,		EA	1
	5120-293-2452	WRENCH, SOCKET		EA	1

By Order of the Secretary of the Army:

Official:

VERNE L. BOWERS
Major General, United States Army
The Adjutant General

CREIGHTON W. ABRAMS
General, United States Army
Chief of Staff

Distribution:

To be distributed in accordance with DA Form 12-25A (qty rqr block no. 122), Organizational maintenance requirements for Fire Fighting Equipment.

U.S. GOVERNMENT PRINTING OFFICE: 1973-769620-1107
221-255

GPO 8908761

CHANGE

No. 1

HEADQUARTERS
DEPARTMENT OF THE ARMY
WASHINGTON, D.C., 1 September 1966**Operator and Organizational Maintenance Manual****TRUCK, FIRE FIGHTING: POWERED PUMPER; FOAM AND WATER, 500-GPM; CENTRIFUGAL PUMP, POWER TAKE OFF DRIVEN; 400-GAL WATER TANK, 40 GAL FOAM CHEMICAL TANK (WARD LAFRANCE MODEL M44A1WLF) NON-WINTERIZED FSN 4210-225-9127 (WARD LAFRANCE MODEL M44A2WLF-W) WINTERIZED, FSN 4210-965-1306**

TM 5-4210-205-12, 11 December 1964, is changed as follows:
Title is changed as shown above.
Page 100, chapter 6 is added after chapter 5.

CHAPTER 6**WINTERIZATION****Section I. GENERAL****145. Scope**

a. This supplement is published to provide operating and maintenance instructions for the winterization kit supplied with the Ward LaFrance Model M44A2WLF Fire Truck.

b. The winterization kit is designed to provide heat to maintain equipment and components at an operable temperature and prevent fluid in the components and water tank from freezing when ambient temperature range is from +20°F to -65°F.

Section II. DESCRIPTION**146. Description**

The winterization kit consists of four separate components which can be operated independently: an engine radiator shutter mechanism (fig. 71.1) which can be adjusted to restrict the amount of air flowing through the engine radiator; a liquid heating unit (fig. 71.2) which heats and circulates liquid through the engine, engine crankcase, battery compartment, personnel heater, water tank, and foam tank; a space heater (fig. 71.3) which heats and circulates air through the pump compartment, hose reel compartment, and equipment

compartments; and an auxiliary motor-generator set (fig. 71.4) which enables the winterization kit to be operated with the fire truck engine at rest.

147. Engine Radiator Shutters

(fig. 71.1).

The engine radiator shutter assembly is mounted directly in front of the engine radiator. A control cable connects the control knob,

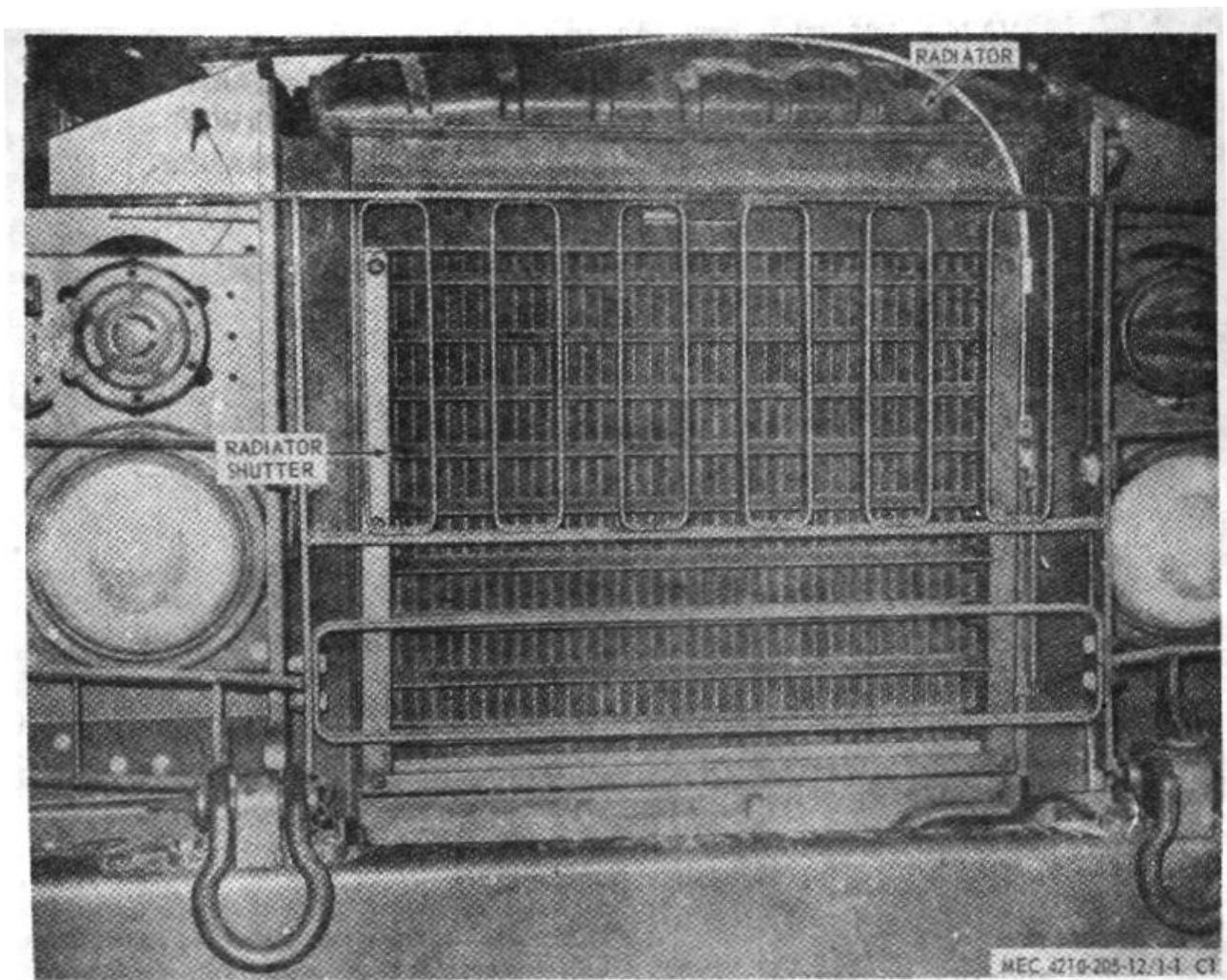

Figure 71.1. Engine Radiator Shutter.

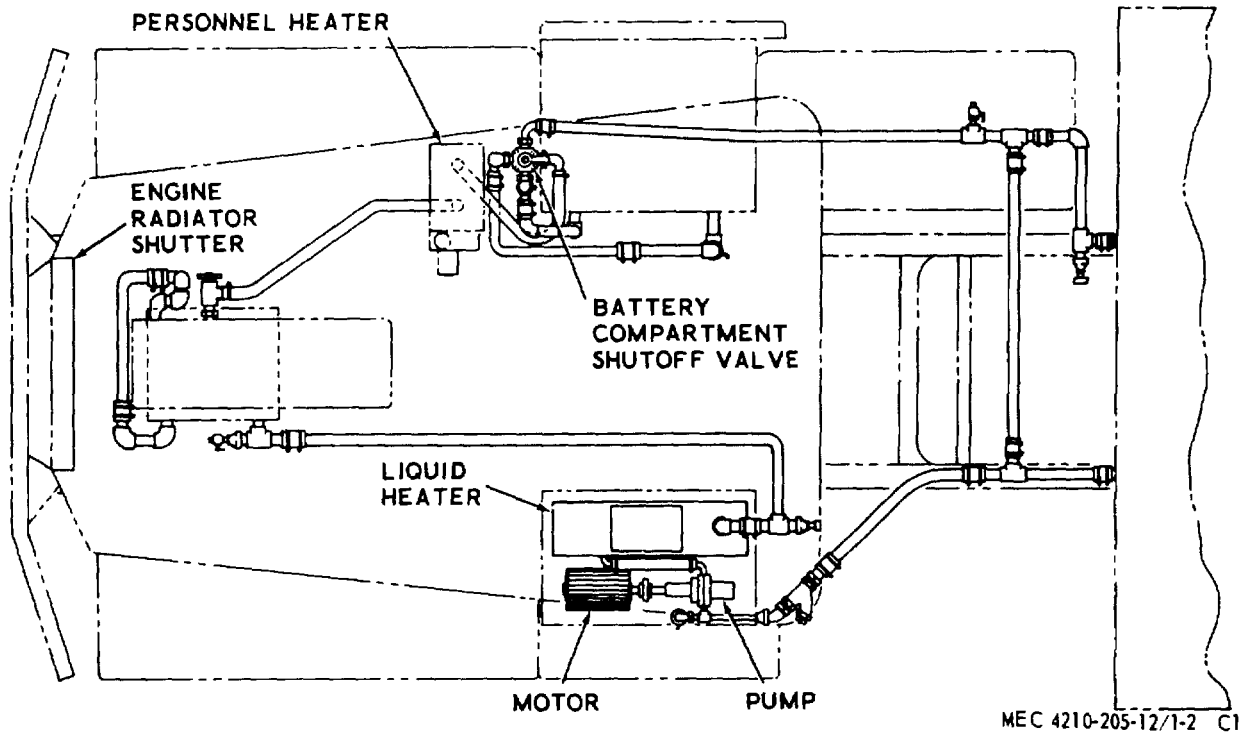

Figure 71.2. Fluid heating system diagram.

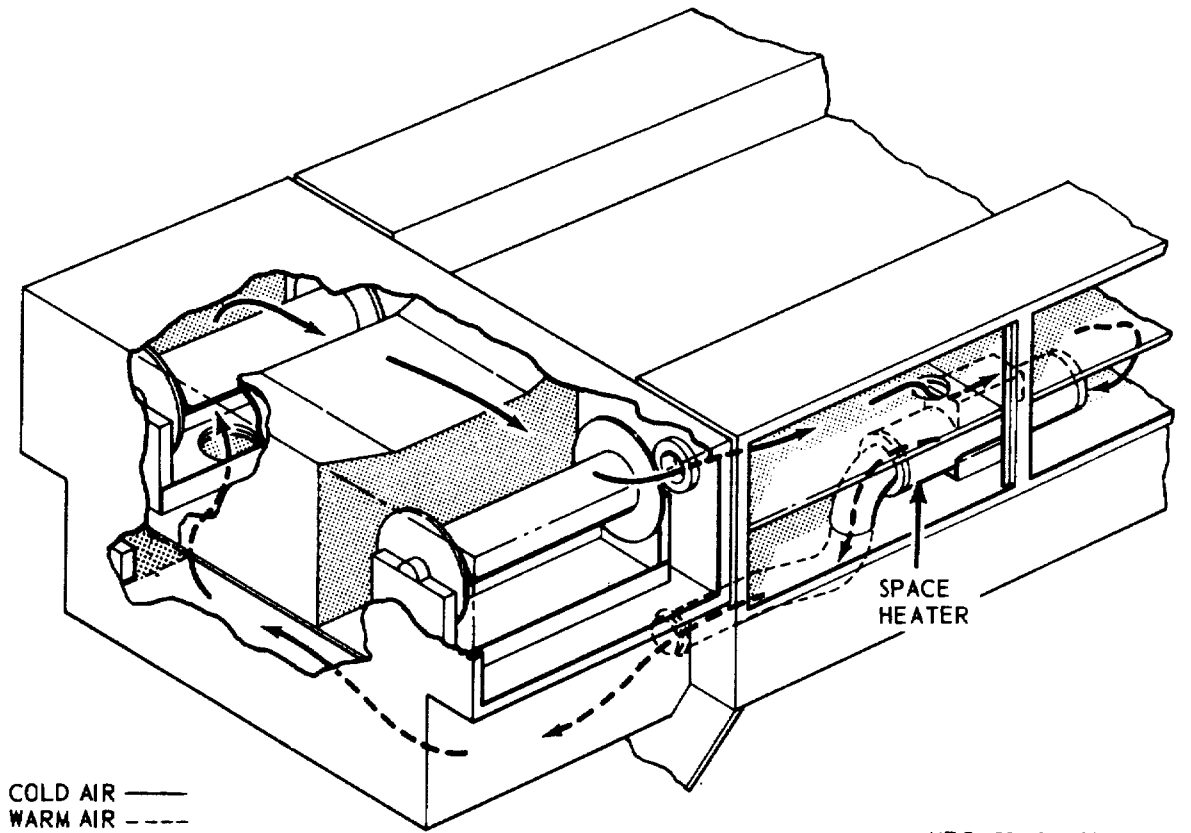

Figure 71.3. Space heater system diagram.

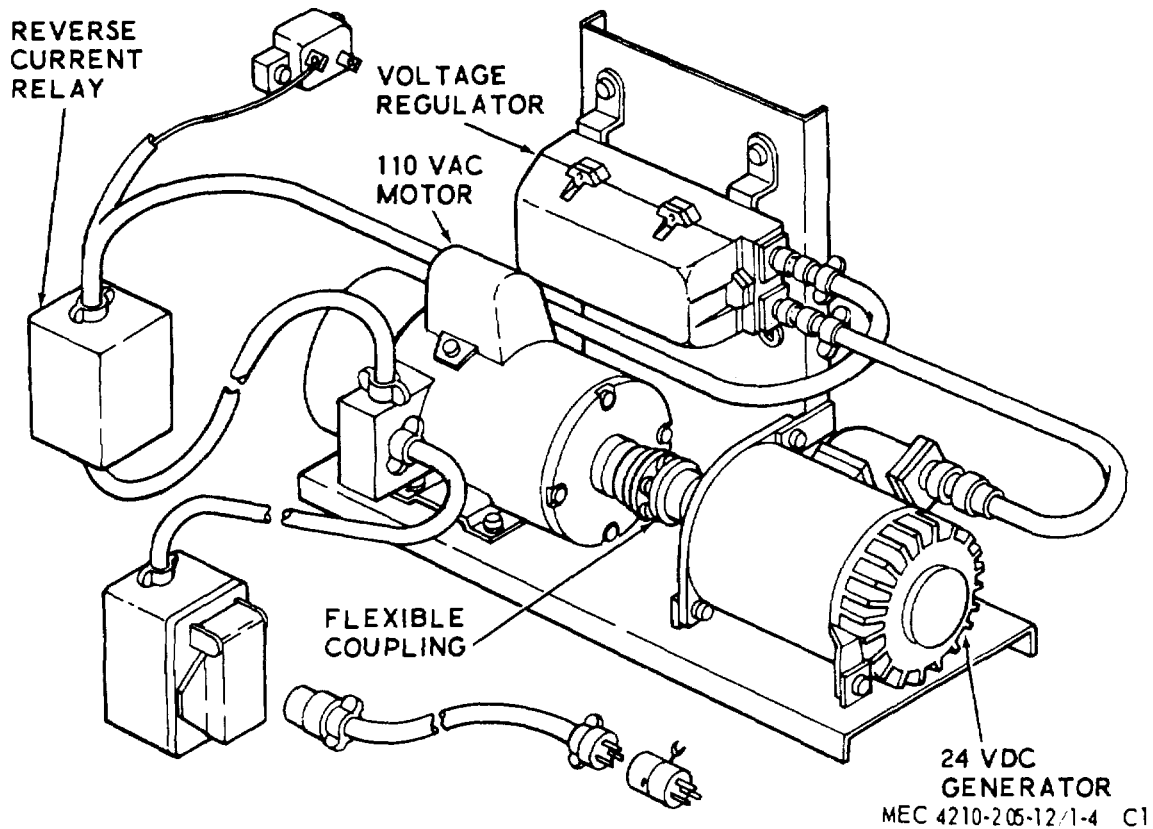

Figure 71.4. Motor-generator set.

Heat Output (BTU per hr) 60,000

Dimensions:

Length 24 in. (approx)
 Width 8 1/2 in.
 Height 12 in.

Weight (heater only) 30 lbs
 Inlet and Outlet Fittings 3/4 in. I.P.S.

Fuel Consumption High

Fire (bal per hr) 0.75

Watts (running) 40-50

Maximum Ignition Voltage

(normal rate) 12%

Minimum Ignition Voltage

(normal rate) 85%

Minimum Operating Volt-

age (normal rate) 75%

Voltage (nominal) 24 Volts DC

Fuel Gasoline, kerosene, fuel
 oil, diesel oil, JP-4

Fuel Inlet 1/8 in. NPT (female)

Mounting Position Horizontal

Radio Suppression In accordance with U.S.

Army Specification

MIL-I-10379 (SIG-C)

Electrical Connections Receptacle

Figure 71.5. Fluid heater specifications.

located in the instrument panel, to the shutters. The shutters can be manually adjusted to an infinite number of positions from fully open to fully closed to control the flow of air through the radiator.

148. Liquid Heater

149.

The liquid heater is designed to heat liquid contained in the truck engine. The heater utilizes any grade of gasoline, kerosene, M.1,

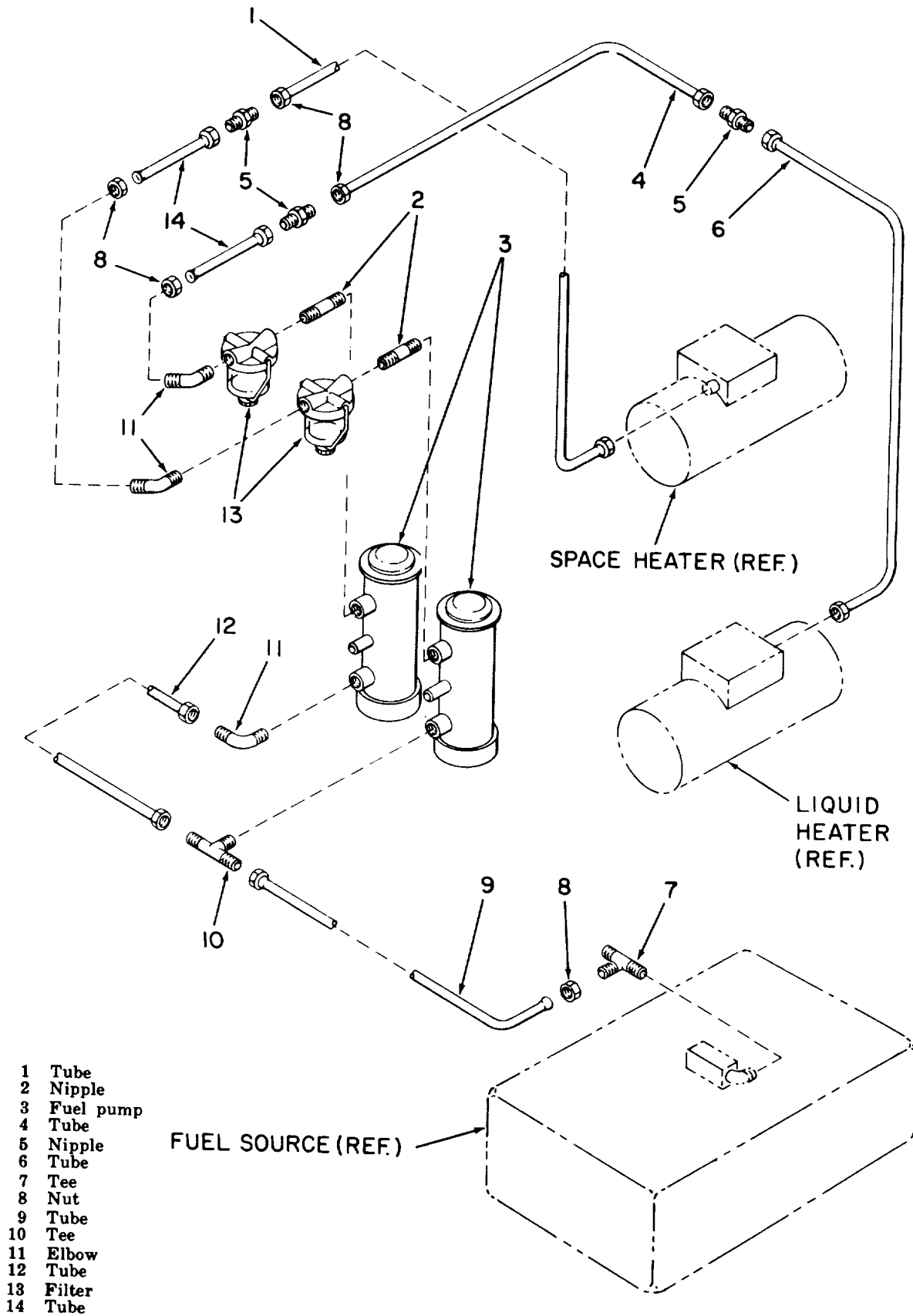

MEC 4210-205-12/1-6 C1

Figure 71.6. Fuel system diagram.

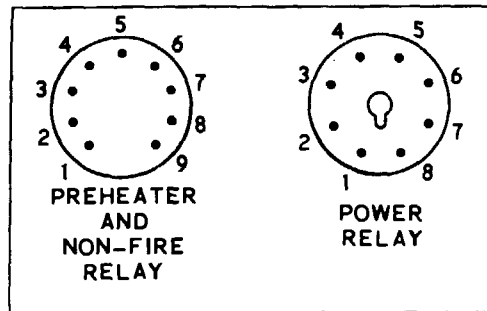

PIN DIAGM

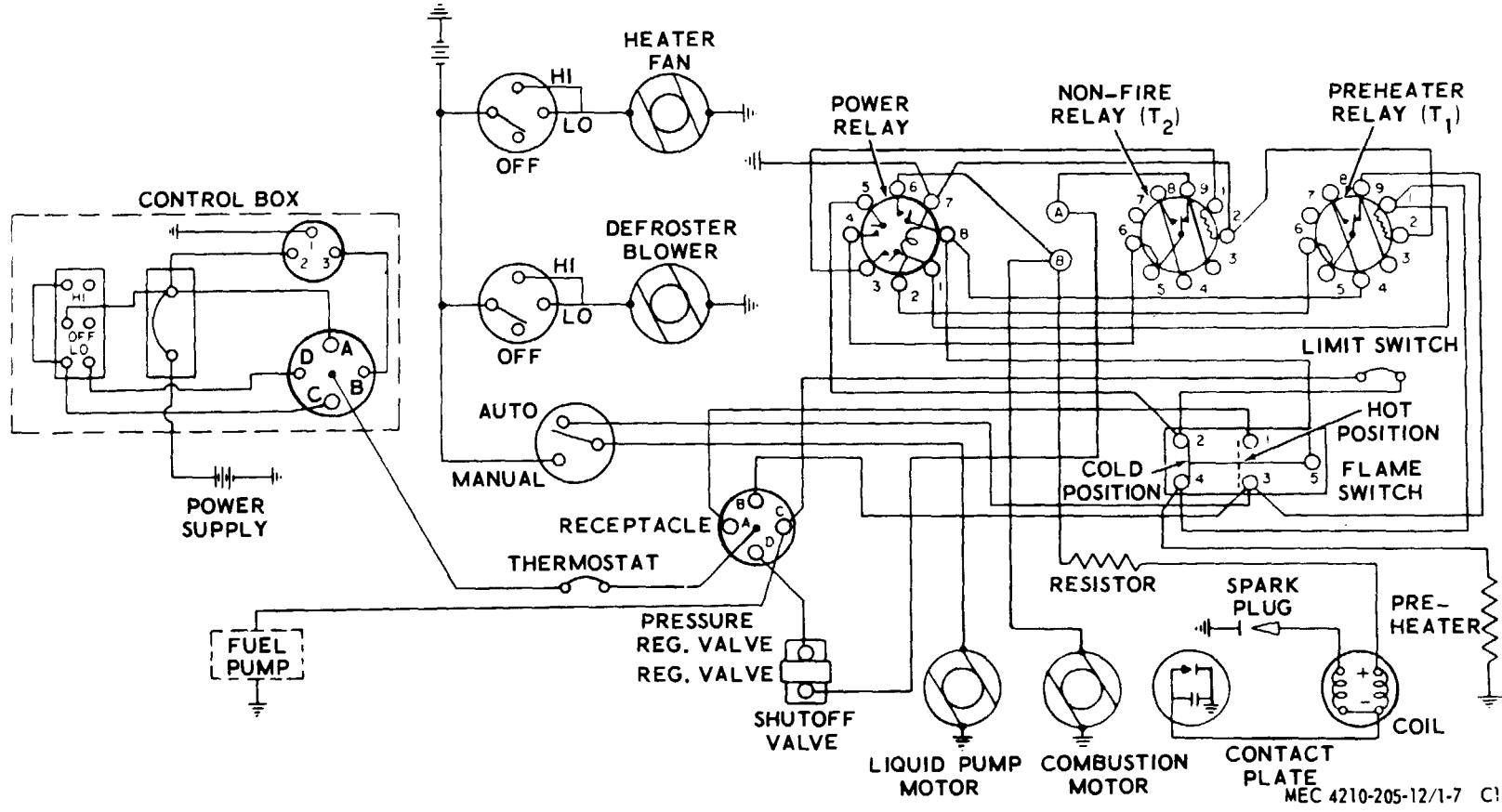

Figure 71.7. Fluid heater system electrical diagram.

M.2, or M.3 fuel oil or JP-4 fuel as a combustible. The electrical requirement is 24 volts-direct current (dc). Refer to figure 71.5 for specifications.

150. Liquid and Air Systems

a. Liquid Flow System. The liquid flow system operates in conjunction with the combustion air flow system to transfer the heat of combustion from the burner to the liquid to be heated. The combustion chamber provides passages through which the liquid flows. The combustion air is circulated around these passages so that the chamber functions as a heat exchanger. The liquid is forced into the inlet port at the side of the combustion chamber by an externally mounted liquid pump. It leaves the heater through the fitting at the top of the combustion chamber. The liquid pump is powered by the electrical circuit of the heater.

b. Combustion Air System. The combustion air system provides the air to maintain combustion. The air system consists of a blower motor fan and the necessary air passages. The air enters the heater through the larger opening in the heater base, passes through the combustion air blower shell and into the burner. The air mixes with the fuel vapor in the burner and combustion occurs. The hot, contaminated combustion air passes through ports at the far end of the combustion chamber, into the secondary heat exchanger. During this time, much of its heat is transferred to the liquid. The air leaves the heater through the centrally located exhaust opening.

151. Fuel Systems

(fig. 71.6).

The heater fuel system provides a constant flow of liquid fuel to the burner for combustion, and operates in conjunction with the heater electrical system. Fuel is supplied through a fuel pump and filter to the heater, and reaches the combustion chamber through the regulator valve and nozzle.

a. Fuel Pump. The fuel pump is electrically connected to the heater operating circuits and supplies fuel at low pressure to the regulator valve. The pump is self-priming, requiring no bleeding or adjustment on first start.

b. Regulator Valve. The regulator valve, mounted in the control head, consists of two parts-one is a solenoid-operated shut-off valve and the other is a high-low pressure regulator which varies the pressure of the fuel being supplied to the nozzle assembly for high- or low-fire operation.

c. Nozzle Assembly. The nozzle assembly is contained in a tee, which is connected to the regulator valve outlet port by an elbow. The nozzle is a thin plate orifice through which fuel is metered to the burner, and works with the regulator valve to assure a constant, smooth metered flow of fuel regardless of the fuel used.

d. Burner. The burner is of the modified vaporizing-pot type with a porous ceramic burner wick mounted in its base. Fuel enters the burner through the fuel inlet connection, saturates the wick, and combustion occurs in the burner throat and the combustion chamber.

152. Electrical System

(fig. 71.7).

The heater electrical system controls the operations of the fuel, liquid, and air systems throughout the complete heater cycle. It also provides safeguards against electrical and mechanical failures. The remotely mounted control box assembly controls the circuits from the power source to the heater and the fuel pump through a connecting cable assembly.

a. Control Box Assembly.

- (1) The control box assembly contains a circuit breaker, control switch, and indicator lamp.
- (2) The circuit breaker protects the system if an electrical failure occurs. Located in the power circuit to the system, the circuit breaker can disconnect the system entirely when the reset button is pulled out. Never pull the reset button, however, while the heater is in operation, since this will eliminate the heater purging cycle.
- (3) The control switch is a double-pole, double-throw switch with "ON-HI, OFF, ON-LO" positions. The heater starts operating when the thermostat calls for heat after the switch is moved

to either ON position. In the ON-LO position the control switch closes a circuit to the fuel regulator to reduce fuel flow.

- (4) The indicator lamp glows after the heater reaches operating temperature and continues to glow until the heater extinguishes and the combustion chamber cools. The indicator lamp also provides a check of the power supply to the heater. A spring-loaded terminal on the lamp socket is connected to the circuit breaker, so the lamp glows when pressed in if the circuit breaker button is in and power is available.

b. Flame Switch Assembly. The flame switch assembly is a mechanically operated device which controls the electrical circuits during heater operation. It consists of a frame supporting a microswitch and a heat-resisting tube encasing a quartz rod. The tube extends into the combustion chamber and is subjected to the heat resulting from combustion. The difference in expansion of the metal tube and the quartz rod when heated trips the microswitch. The switch automatically restores itself to the normal position when it cools.

c. Preheater Assembly. The preheater assembly is an imbedded coil of resistance wire encased in a metal sheath and mounted within the burner. It is energized only when the heater is initially started. The preheater heats the burner in preparation for the incoming fuel for combustion. This vaporizes the fuel so that it can easily be ignited.

d. Preheat Relay. The preheat relay is a thermal-type, time-delay relay which delays energizing the power relay that controls the ignition system, for approximately one minute until the preheater sufficiently heats the burner to allow fuel vapor to ignite.

e. Power Relay. The power relay is a coil operated relay that controls the circuits to the combustion air blower, ignition system, and the fuel regulator valve during normal heater operation. The flame switch supplies energy to the power relay coil through the preheat relay.

f. Non-Fire Relay. The non-fire relay is a thermal-type, time-delay relay which is a safety device incorporated into the heater electrical system to stop fuel flow if ignition fails to occur two minutes after the heater is turned on. The relay heater element is energized by a circuit through the power relay and the flame switch in cold position. If the flame switch does not trip to hot position, the relay will break the circuit to the fuel regulator valve.

g. Ignition System. The ignition system consists of a spark plug, ignition coil, condenser, and contact set similar to automotive systems. The contact set is a mechanical interrupter, operated by a cam collar on the combustion air motor shaft, which causes the ignition coil to energize the spark plug to ignite the fuel vapor. The spark plug, located in the burner, creates a spark between its electrode and the ground electrode in the burner base, causing fuel ignition. The ignition system is thoroughly shielded for suppression of radio frequencies.

h. Limit Switch. The overheat limit switch shuts the heater off by breaking the primary power circuit if the temperature of the liquid rises beyond a safe limit. The switch incorporates a manual reset button which must be pressed to close the circuit again for further heater operation.

i. Thermostat. The thermostat is an adjustable heat sensor which is electrically connected to the control box. When the liquid has attained the preset temperature, the electric circuit is opened, stopping the heater operation. The circuit is closed when the liquid temperature is below the thermostat adjustment allowing the heating cycle to be completed.

j. Motor Switch. A two position switch permits operation of the liquid pump without the heating cycle. When the switch is in the automatic position, the electrical circuit is connected directly to the liquid heater system. With the switch in the manual position, the electrical circuit is disconnected from the liquid heater system and a circuit is completed to an electrical source, allowing the pump to circulate fluid.

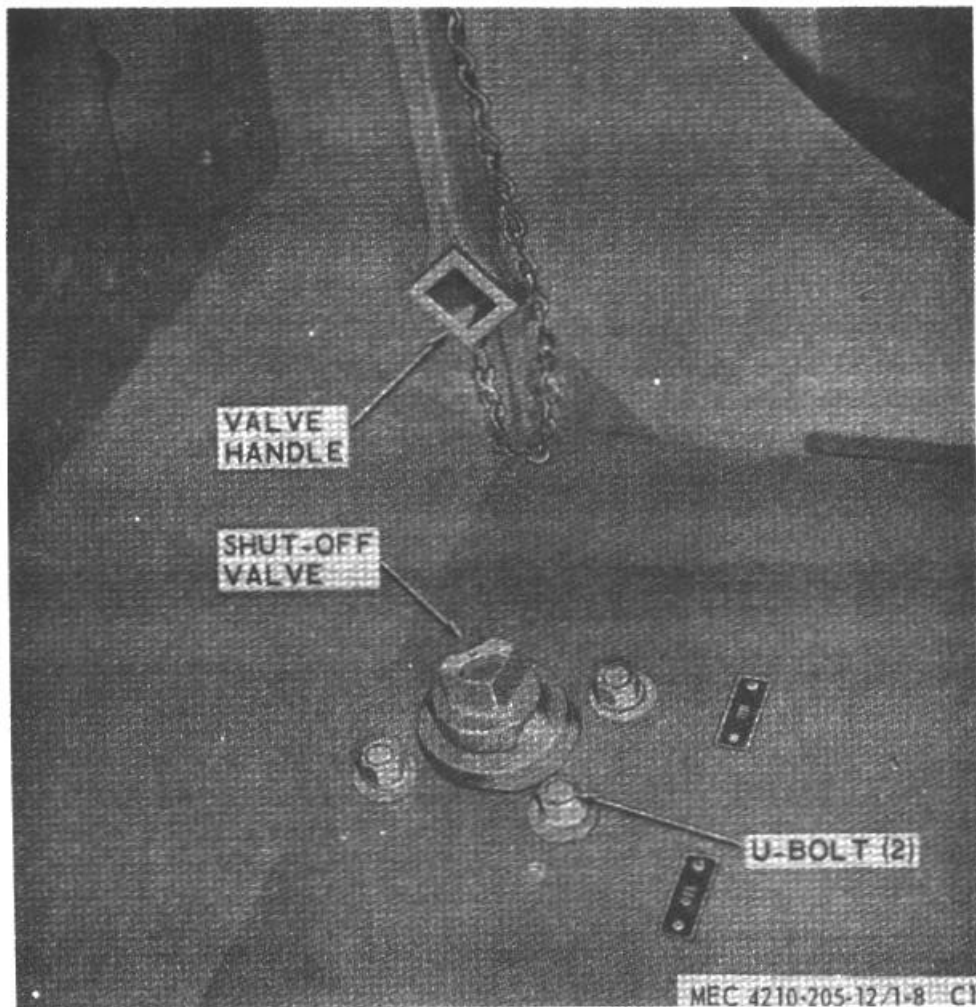

Figure 71.8. Battery compartment shut-of valve.

153. Battery Compartment Shut-off Valve

154.

A 4-way valve (fig. 71.8) allows the heated fluid to by-pass the battery compartment to prevent overheating the storage batteries.

155. Personnel heater

156.

The personnel heater (fig. 71.9) utilizes liquid which has been heated by the liquid heater on the engine, to provide warm air to the cab of the truck. The heated fluid circulates through a honeycomb core in the

personnel heater. An electrically operated fan causes air to flow through the core, where heat is transferred from the heated liquid, and circulated throughout the cab. A separate blower diverts warm air from the heater core, through apertures in the instrument panel, to the windshield to eliminate and prevent frost and fogging conditions on the glass.

157.

When the exterior temperature is not sufficiently cold to warrant use of the liquid heater, the personnel heater may be used by actuating the circulating pump in the liquid heating system, utilizing liquid which has been heated by the truck engine to supply the heater core.

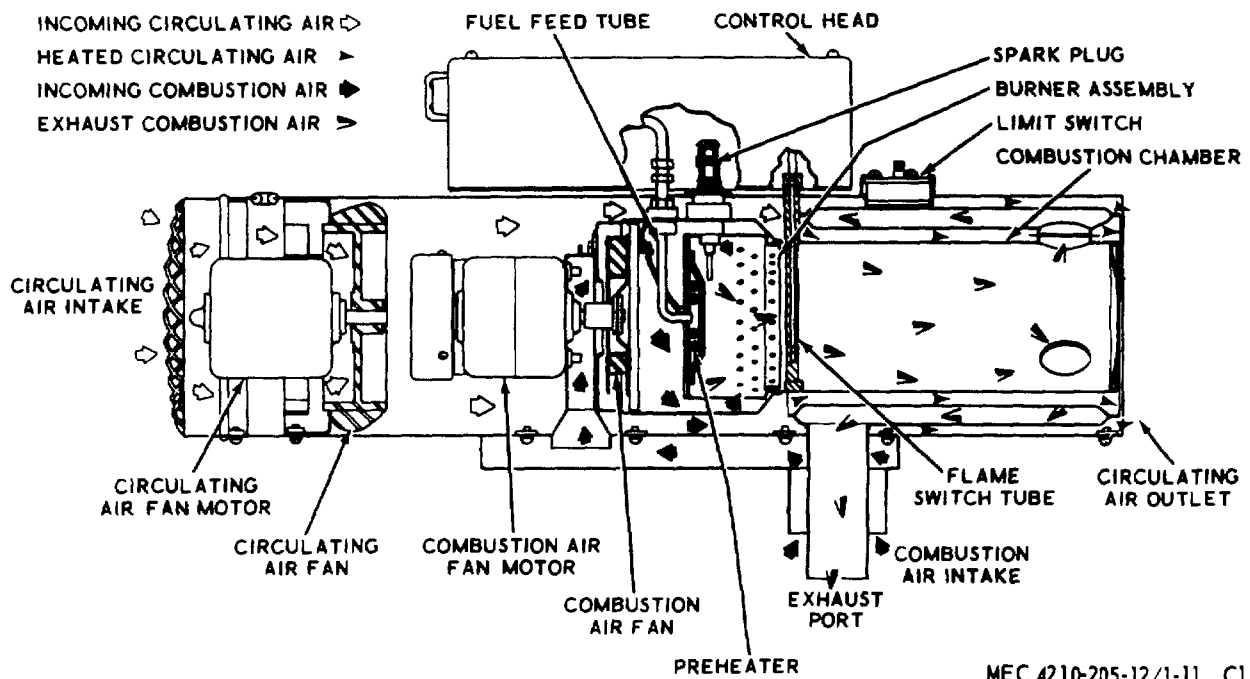

MEC 4210-205-12/1-11 C1

Figure 71.11. Space heater flow diagram.

system. Each system consists of a blower motor, fan, and the necessary air passages.

a. Fresh Air System. To circulate fresh air for heating and distribution to the compartment, the fresh air fan draws air through the opening at the rear of the heater. The fresh air passes over and cools the motors, then passes around the burner unit and through a passageway between the combustion chamber and the inner wall of a secondary heat exchanger. It also passes between the heater outer casing and the outer wall of the heat exchanger.

b. Combustion Air System. Air for the combustion chamber enters the heater through the larger opening in the heater base, passes through the combustion air blower shell and into the burner. The air mixes with the fuel vapor in the burner, and combustion occurs. Contaminated combustion air passes through parts at the far end of the combustion chamber, into the secondary heat exchanger, and leaves the heater through the centrally located exhaust opening.

160. Fuel System

The fuel system for the space heater is identical to

the liquid heater system. Refer to paragraph 151 for details.

161. Electrical System

The space heater is similar to the liquid heater electrical system described in paragraph 152 with the exceptions of the pump switch and personnel heater and defroster switch which are omitted and the variations in the internal wiring (fig. 71.12 for the wiring diagram).

162. Motor-Generator Set

(fig. 71.13).

A 115 volt ac electric motor coupled to a 24 volt dc generator provides an electrical source to maintain the vehicle storage batteries at full charge while operating the winterization kit with the truck engine at rest. Facility electrical source to operate the motor is connected to the vehicle by a 50-foot cable. The generator is protected from damage caused by excessive current draw by a 30 amp circuit breaker. A reverse current relay prevents current draw from the battery when the electric motor is not operating.

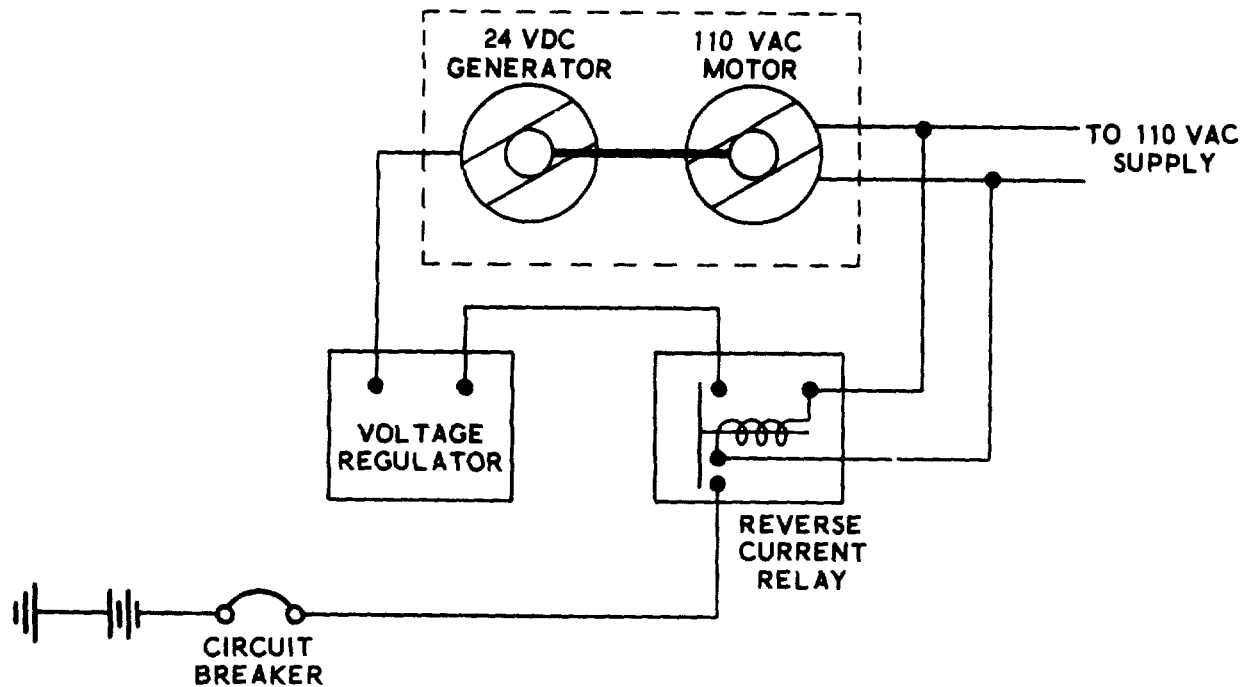

MEC 4210-205-12/1-13 C1

Figure 71.13. Motor-generator set wiring diagram.

Section III. OPERATION

163. General

This section of the supplement contains complete operating instructions for all components of the winterization kit.

164. Engine Radiator Shutter

a. Pull the control knob (fig. 71.14) outward to close the shutters, restricting air flow through the radiator.

b. When the engine temperature gage indicates approximate operating temperature, push the control knob in to adjust the shutters in a position which allows sufficient air flow to maintain the engine operating temperature.

c. Push the control knob fully in to open the shutter to maximum aperture.

165. Liquid Heating System

166. Liquid Heater

a. Starting.

(1) Depress the lens of the indicator lamp to

make sure power is available for operation. If the lamp lights, power is available. If the lamp fails to light when depressed, press the reset button to see if the circuit breaker is tripped, and repeat the test.

(2) Set the control switch to either ON position. (When the "ON-LO" setting is used, the heat output is lower than for high-fire operation.)

(3) Preheating takes place for approximately one minute, after which time the ignition cycle starts. After approximately another minutes, the control box indicator lamp will glow and the heater will circulate warm liquid.

Note. For one minute after the control switch is turned on, the heater will indicate no visible or audible signs of operation until the preheater element heats the burner sufficiently to cause combustion. If the control box indicator lamp glows 1 1/2 to 2 minutes after heater was turned on, the heater is operating properly.

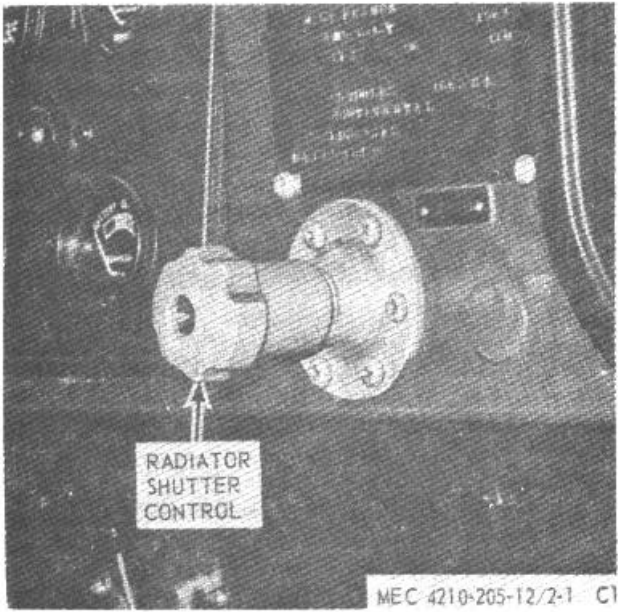

Figure 71.14. Engine radiator shutter control.

Note. When the heater is started for the first time after installation, or at the beginning of the heating season, air trapped in the fuel lines may prevent sufficient fuel from reaching the heater on the timed ignition cycle. If the indicator lamp does not light after three minutes, turn control switch to OFF position. Check the reset button in the control box. Wait five minutes; then restart heater. If the heater still does not operate properly, shut the unit off and check for the difficulty, following instructions in maintenance and repair.

b. Stopping. The heater stops automatically when the proper temperature is reached. Placing the control switch in "OFF" position stops heater operation. The heater will continue to operate, and the indicator lamp will glow, for approximately two minutes after shutdown.

Caution: Pulling out on the circuit breaker button on the control box breaks all the electrical circuits to the heater. Do not attempt to stop heater operation with the circuit breaker.

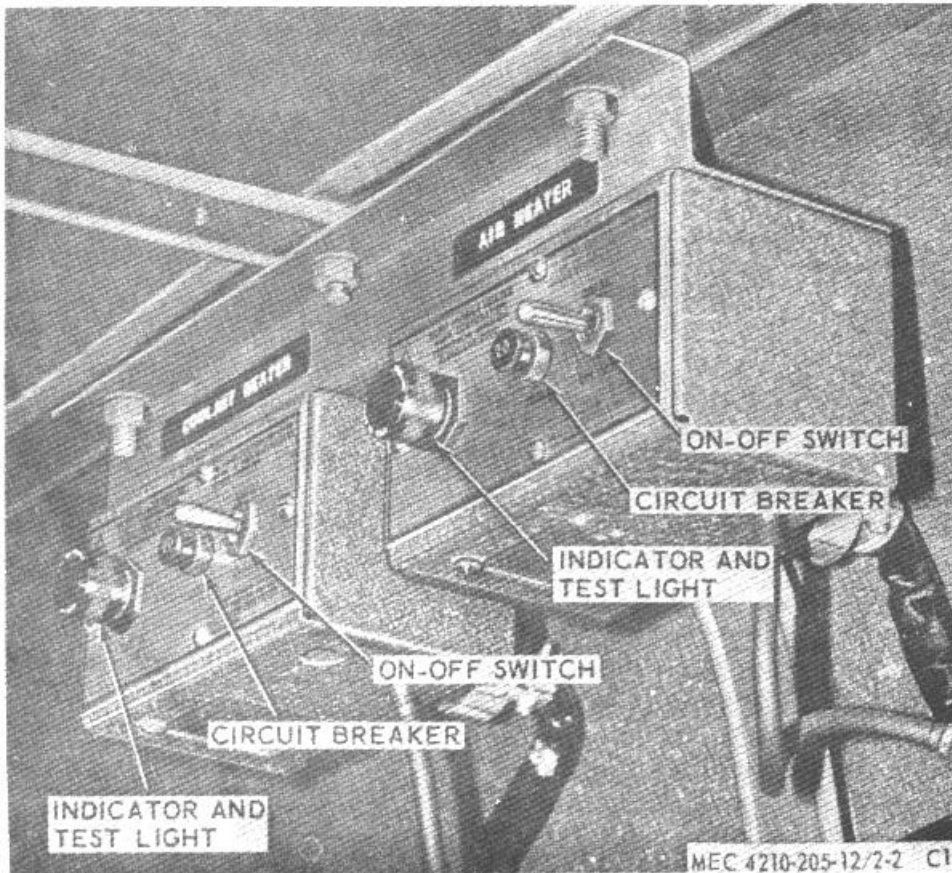

Figure 71.15. Liquid heater and space heater controls.

Stopping heater operation with the circuit breaker prevents the heater from purging itself at the end of the operating cycle.

167. Personnel Heater

The personnel heater can be operated utilizing heated fluid from either the vehicle engine or the liquid heater.

a. *Heater.* Pull heater switch knob (fig. 71.16) outward to actuate the fan. Open the heater doors to allow the air to circulate.

b. *Defroster.* Pull defroster switch outward to actuate the defroster blower.

168. Operation Without Liquid Heater

Position switch (fig. 71.17) to actuate the pump. Operate the heater as described in paragraph 167.

169. Battery Compartment Valve

(fig. 71.8).

Place handle on the valve stem. Turn the handle to the desired position.

170. Space Heater

171. Operation

a. Starting.

(1) Depress the lens of the indicator lamp (fig. 71.15) to make sure power is available for operation. If the lamp lights, power is available. If the lamp fails to light when depressed, press the reset button to see if the circuit breaker is tripped, and repeat the test.

(2) Position the control switch to either of the ON positions.

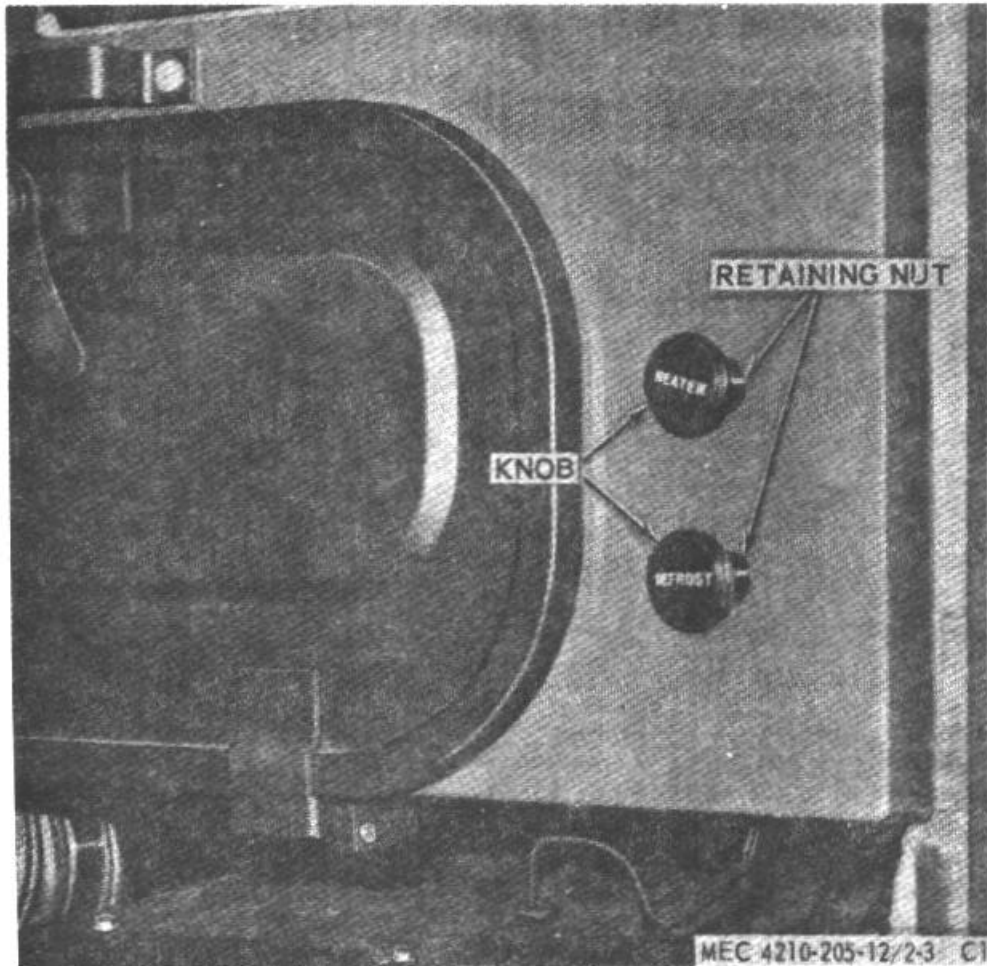

Figure 71.16. Personnel heater controls.



- (3) Preheating takes place for approximately one minute, after which time the ignition cycle starts, and the combustion blower operates. After approximately another minute, the heater will circulate warm air, and the control box indicator lamp will glow to indicate that the heater is operating properly.

Note

For one minute after the control switch is turned on, the heater will give no visible or audible signs of operation until the preheater element heats the burner sufficiently to cause combustion. If the control box indicator lamp glows 1/2 to 2 minutes after the heater was turned on, the heater is operating properly. If the indicator lamp does not glow, air may be trapped in the fuel line, preventing sufficient fuel from reaching the heater during the timed ignition cycle. This may happen when the heater is started for the first time after installation or at the beginning of the heating season. If the indicator lamp does not light after three minutes, turn the control switch to OFF AG0 SW7A position. Check the reset button in the control box. Wait five minutes, then restart

heater. If the heater still does not operate properly, shut the unit off and check for the difficulty, following instructions in maintenance and repair.

- b. *Stopping.* Position the control switch in the OFF position.

Caution

Do not use the circuit breaker to stop the heater as the system will not purge when all circuits are open.

Note

When the control switch is in the OFF position, the heater will continue to operate through the purge cycle. The indicator lamp will glow for approximately two minutes after shutdown, until the heater starts to cool.

172. Motor-Generator Set

- a. *Starting.* Connect the 50-foot cable supplied with the winterization kit or equivalent to the motor-generator set receptacle (fig. 71.18) and 115 volt ac electrical source.

- b. *Stopping.* Disconnect the cable.

Note

If the motor-generator set stops, press the reset button (fig. 71.9) to reset the circuit breaker. Shut off unnecessary electrical components to reduce current draw.

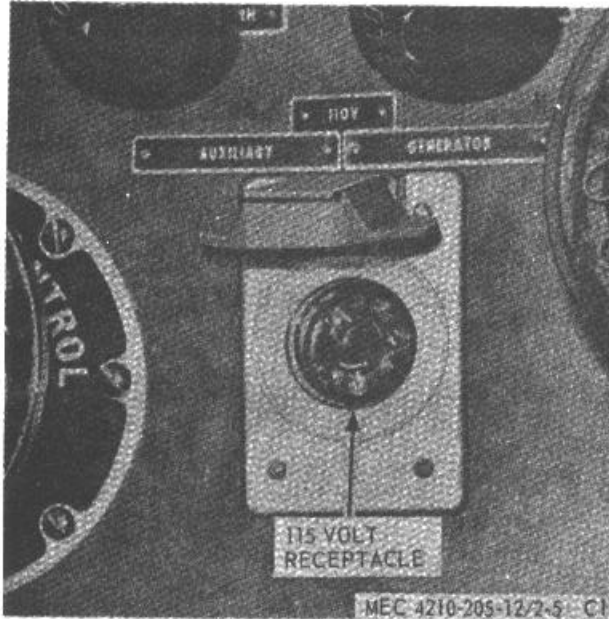

Figure 71.18. 110 VAC receptacle.

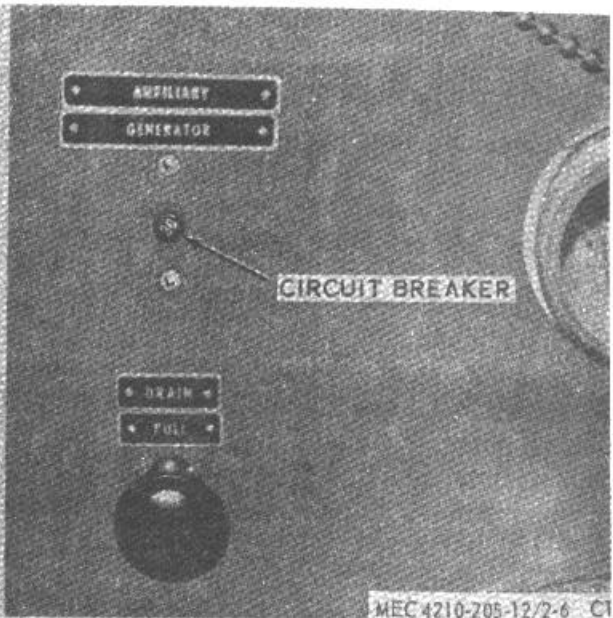

Figure 71.19. Circuit breaker.

Section IV. MAINTENANCE

173. General

The section contains instructions to maintain the winterization kit in an efficient operating condition.

174. Engine Radiator Shutters

- a. Insure that all surfaces and contact points are clean.
- b. Apply a thin coat of lubricant to all pivot points.

175. Liquid Heater

Perform the maintenance procedures listed below at regular intervals to maintain efficient heater operation. No lubrication or additional servicing is required except as noted.

- a. Inspect periodically the spark plug and contact breaker points, since most heater troubles are caused by faulty or dirty ignition components. The spark plug electrode and the insulator should always be dry and clean. The is gap between the contact points should be 0.025 inches.

- b. Make certain all electrical connections are tight. Inspect the insulation on wires and cables for chafing or damage.

- c. Check fuel lines and connections for leaks. Make sure lines are securely fastened. If there is any motion between the heater and the fuel tank, insert a flexible connection at the point of greatest stress.

- d. Clean the fuel filter sediment bowl. Replace the filter element as necessary (fig. 71.6).

- e. Keep the heater and accessories clean, and make certain no obstructions form near the intake and exhaust openings.

- f. Check the heater and its accessories for tight mountings.

176. Space Heater

Refer to paragraph 2-13 for maintenance procedures.

177. Motor-Generator Set

- a. *Motor.* No maintenance required.
- b. *Generator.* Refer to TM 9-2920-209-35 for maintenance procedures.
- c. *Voltage Regulator.* Refer to TM 9-2920-209-35 for maintenance procedures.

d. *Wiring.* Check that all connections are tight. Inspect the insulation for chafing or damage.

178. Lubrication

No lubrication required.

Trouble	Probable Cause	Remedy
Heater fails to ignite	Ignition failure Preheater failure Excessive carbon deposits in burner Fuel system failure Electrical system failure Preheater relay or power relay failure Flame switch failure	Replace spark plug and/or adjust contact points. Replace preheater. Clean burner bowl. Test and repair fuel system (para 181). Test and repair electrical system (par. 2-18). Replace relay. Replace flame switch.
Excessive time required for ignition	Low voltage Fuel flow rate slow	Test batteries for proper operating voltage. Test and repair fuel system (para 181).
Heater starts but fails to keep burning	Nonfire relay failure (fuel shuts off shortly after ignition occurs) Combustion chamber overheated (limit switch stops operation) Burner clogged Vapor lock in fuel line Electrical system failure Timing or power relay failure	Replace nonfire relay. Correct overheating. (Make sure air blower is distributing combustion air adequately.) Check for plugged liquid circulating hoses or passages. Reset limit switch. Clean Burner. Prevent excessive heat near fuel line. Test electrical system (para 180). Replace relay.
Heater combustion surges	Fuel system not supplying steady or proper flow Low combustion air blower motor speed Low voltage	Test and repair fuel system (para 181). Replace motor. Test batteries for proper operating voltage.
Heater smokes	Fuel system not supplying steady or adequate flow Low combustion air blower motor speed Low voltage	Test and repair fuel system (para 181). Replace motor. Test batteries for proper operating voltage.
Heater fails to respond to "ON-HI" and "ON-LO" switch operation	Fuel regulator valve failure	Replace regulator valve.
No warm liquid circulated (Liquid Heater)	Liquid circulating failure Faulty thermoswitch	Replace pump. Replace thermoswitch.
No warm air distributed (Fresh Air Heater)	Circulating air blower failure Faulty thermostat	Replace blower motor. Replace thermostat.

Figure 71.20. Troubleshooting chart

179. Troubleshooting

Refer to fig. 71.20 for probable causes and remedies for malfunctions in the winterization kit. The troubleshooting chart is applicable to both the liquid and fresh air heaters. Refer to applicable paragraphs for additional tests to further analyze malfunctions which may occur within specific components.

180. Electrical System Test

- a. Make certain power supply is adequate for the unit.
- b. Check all electrical connections for tightness and good condition.
- c. Check limit switch. If switch is open, correct the reason for overheating of the heater combustion chamber. Reset limit switch manually.
- d. Check the circuit breaker reset button position on the control box. The power supply circuit is closed when the button is pushed in. If the button jumps out when the heater is started, test further for the electrical failure.
- e. Press in "press-to-test" indicator lamp on the control box. If the power supply circuit through the circuit breaker is complete, the lamp light. If the lamp does not light, make certain the lamp is not burned out.

If the lamp is not faulty, check the power supply and the power circuit through the circuit breaker.

- f. If these steps fail to localize the trouble, check the operation of the preheater, the preheat relay, the power relay, and other electrical components.

181. Fuel System Test

- a. Make certain the feed line shut-off valve is open.
- b. Check the fuel supply. Make certain the fuel is the proper type for the heater and that it is not contaminated.
- c. If the fuel pump is not operating, test as described in paragraph 201.
- d. If the fuel pump is operating, disconnect the pump outlet connections and check for fuel flow. If flow does not occur, check the fuel lines for obstructions. Make sure the fuel filter is clean.
- e. If a flow occurs, reconnect the pump outlet and remove the regulator valve and the nozzle assembly. Test the operation of these units as described in paragraphs 192(d) and 193(b).

Section V. GENERAL

182. General

Repair procedures which are standard or obvious may be excluded from this supplement. In instances where specific instructions have been omitted, procedures shall be performed in accordance with good mechanical practices.

Note

Part numbers for items in this section are included in the TM 5-4210-205-35 Supplement Parts List.

Section VI. BODY CHASSIS OR HULL AND ACCESSORY ITEMS

183. Oil Pan Box Assembly

Refer to TM 5-4210-205-12 for repair procedures.

184. Oil Pan and battery Box Heat Exchanger Assembly

Refer to TM 5-4210-205-12 for repair procedures.

185. Radiator Shutter Assembly

Repair consists of replacement of defective components. Refer to fig. 71.21 for assembly sequence.

186. Heater Control Box Assembly (fig. 71.22)

Remove the two screws (14) on each side of the nameplate (13) and separate the box assembly (10)

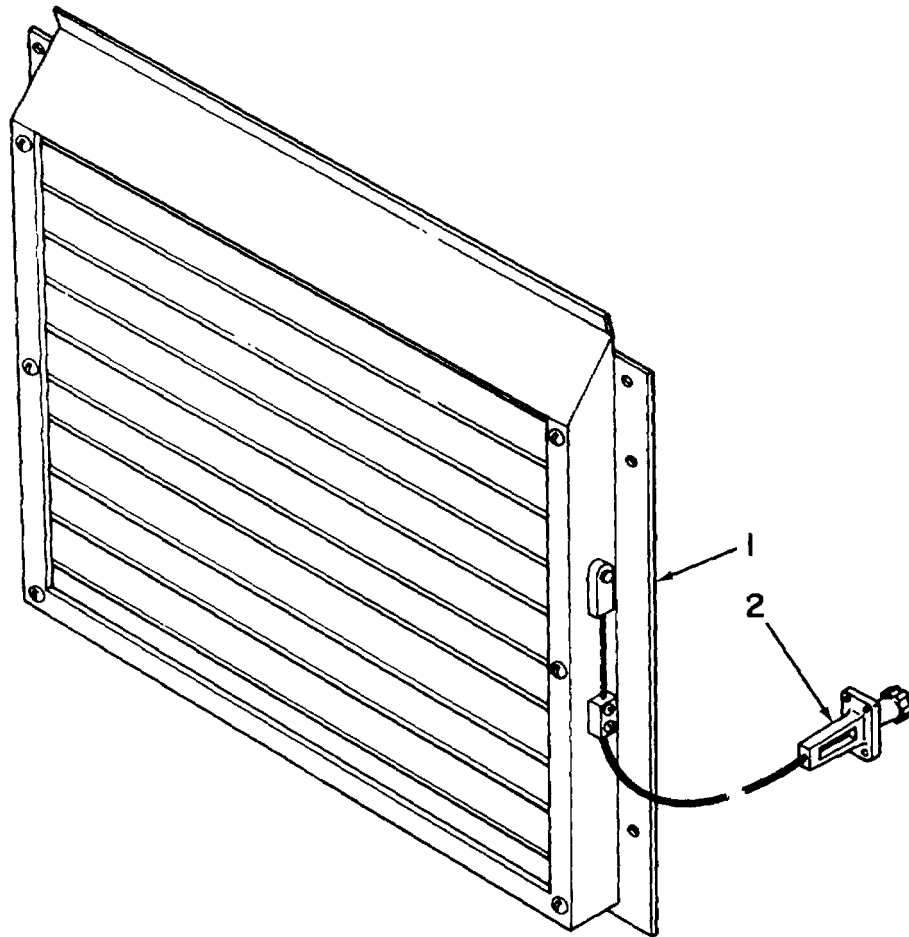

MEC 4210-205-12/3-1 C1

1 Shutter

2 Control

Figure 71 .21. Radiator shutter assembly.

from the panel (18). Inspect the assembly visually for wiring defects and faulty parts. Check the circuits, using the wiring diagram (fig. 71.7). Replace any units that are obviously faulty. Disassemble and test the control box components as follows:

a. Circuit Breaker.

- (1) To remove the circuit breaker (12, fig. 71.22), disconnect the electrical leads from the terminals. Tag leads to facilitate reassembly. Remove two mounting screws (15) from the panel (18) and remove circuit breaker (12).
- (2) To test, connect the circuit breaker to a test circuit which will supply 200 percent rated current. Press in the reset button;

the circuit breaker should open within 10 to 125 seconds. If it fails to meet this requirement, replace the circuit breaker.

- (3) To install the circuit breaker, position it on the panel and fasten in place with the two mounting screws. Connect the leads according to the wiring diagram (fig. 71.7.)

b. Control Switch.

- (1) To replace the control switch, disconnect the electrical leads. Tag leads to facilitate reassembly. Remove the mounting nut from the threaded lever lug. Remove

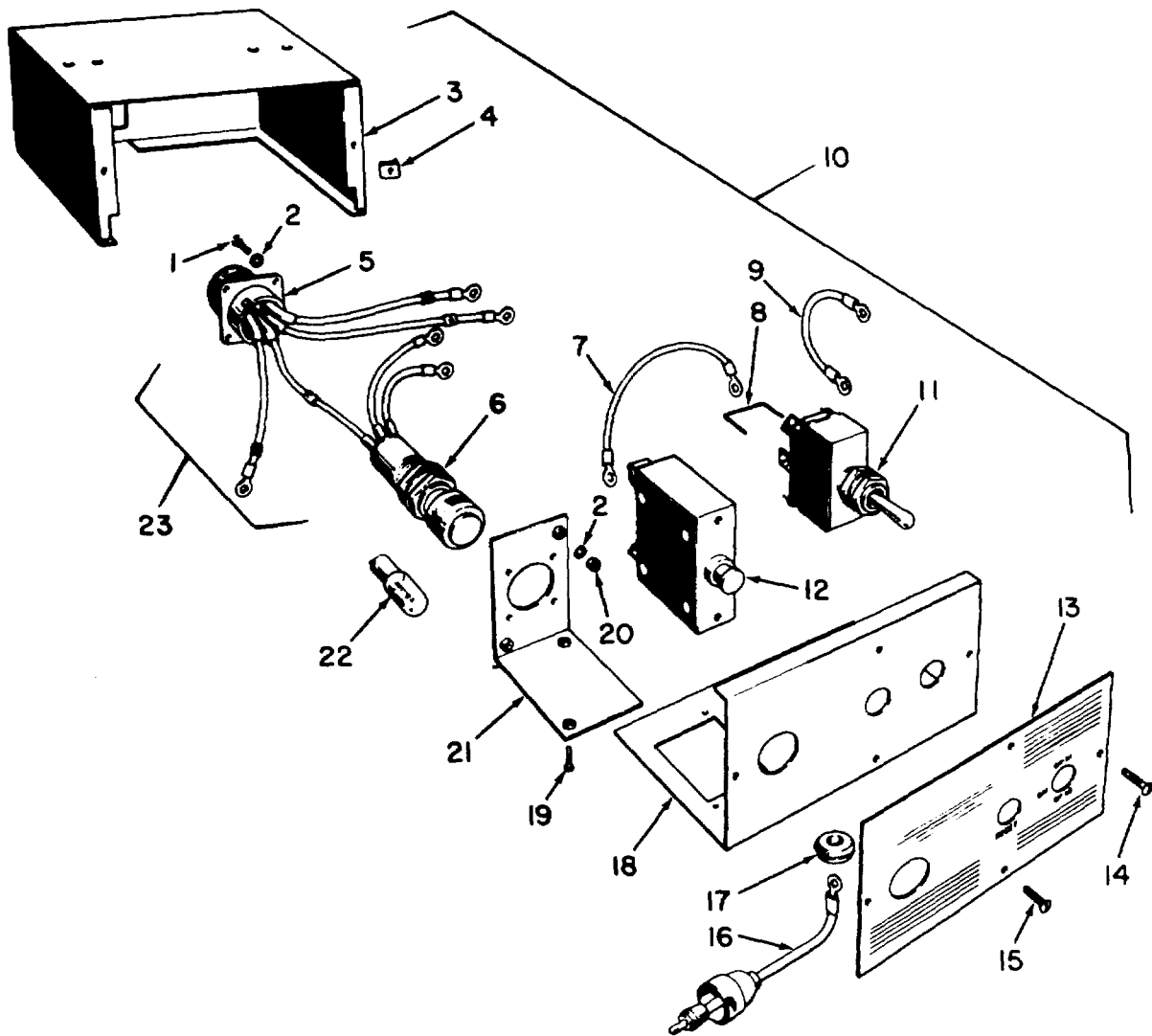

MEC 4210-205-12/3-2 C1

- | | | | | | |
|---|-----------|----|------------------|----|------------------------------|
| 1 | Screw | 9 | Lead | 17 | Grommet |
| 2 | Washer | 10 | Distribution box | 18 | Panel |
| 3 | Box | 11 | Switch | 19 | Screw |
| 4 | Nut | 12 | Circuit breaker | 20 | Nut |
| 5 | Connector | 13 | Plate | 21 | Bracket |
| 6 | Light | 14 | Screw | 22 | Lamp |
| 7 | Lead | 15 | Screw | 28 | Connector and light assembly |
| 8 | Wire | 16 | Lead | | |

Figure 71.22. Heater control box assembly.

- control switch (11, fig. 71.22) from panel (18).
- (2) Check switch continuity with an ohmmeter in all positions. Make sure the switch operates freely. Replace if faulty.
- (3) To install the control switch (11), position on the panel and secure with the mounting nut. (Make certain the switch lever correctly indicates "ON-HI, OFF, ON-LO" operation on the plate.) Connect the leads according to the wiring diagram (fig. 71.7.)

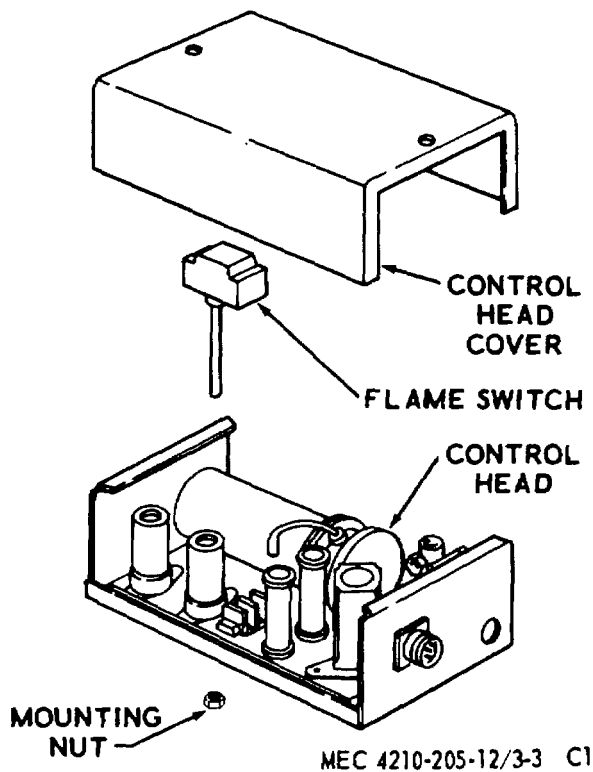

Figure 71.23. Flame switch removal and installation.

c. *Indicator Lamp.*

- (1) To replace the indicator lamp (22, fig. 71.22), remove the lamp button from the light socket (6); then remove lamp (22).
- (2) Replace the lamp socket or the receptacle, remove both as an assembly (2.3). Disconnect the wires leading to the control switch, circuit breaker, and ground. To remove the connector (5), remove the screws (1), washers (2), and nuts (20) fastening the connector to the angle bracket (21). Remove the light socket (6) by removing the lamp button and external mounting nut. Inspect the indicator light socket and receptacle for broken leads, damaged terminals, and worn or damaged threads. If any parts are faulty, replace the entire assembly.
- (3) To install the connector and light assembly (23), insert the light socket through the hole in the panel (18) and

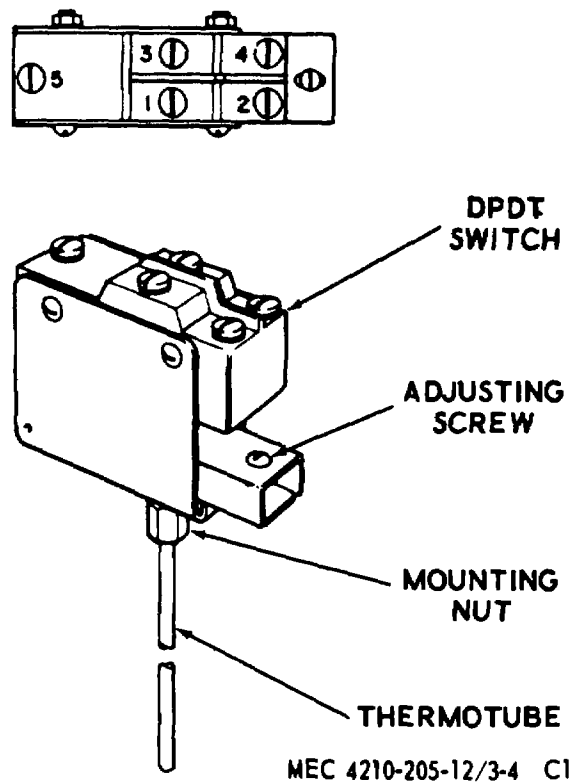

Figure 71.24. Flame switch adjustment.

plate (13). Fasten in place with the external mounting nut and install the button.

- (4) Fasten the receptacle to the angle bracket (21) with the mounting screws, washers, and nuts (1, 2 and 20). Connect the wires according to the wiring diagram (fig. 71.7). The ground wire from the lamp connects to a receptacle mounting nut.

187. Flame Switch, Liquid and Space Heaters (fig. 71.23).

a. *Removal.* Remove the control head (para 192) and remove control head cover. Disconnect the wires from the terminals of the flame switch. Unscrew the flame switch mounting nut and remove the flame switch.

b. *Flame Switch Adjustment* (fig. 71.24).

- (1) The adjusting screw is a spring-loaded screw at the open end of the switch frame. It adjusts the travel of the actuating pin of the switch.

- (2) With the flame switch at room temperature, loosen the adjusting screw until a distinct click is heard. Then tighten the screw until a second click occurs. At this point continue to tighten for three-eighths of a turn to correctly position the adjusting screw.

c. *Flame Switch Test.*

- (1) At room temperature, check for continuity across terminals 2 and 4 and terminals 2 and 5 (fig. 71.23) with an ohmmeter. If continuity exists, continue the test.
- (2) Apply heat to the flame switch tube. The switch should change to hot position at 400° to 500°F. Continuity should now be across terminals 1 and 2 and terminals 1 and 5. Allow the

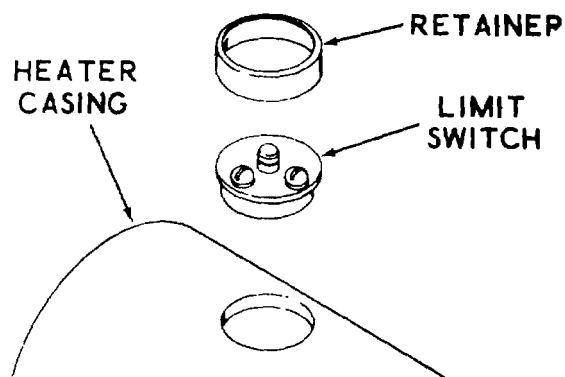

MEC 4210-205-12/3-5 CI

Figure 71.25. Limit switch, removal and installation.



Figure 71.26. Circulating pump switch.

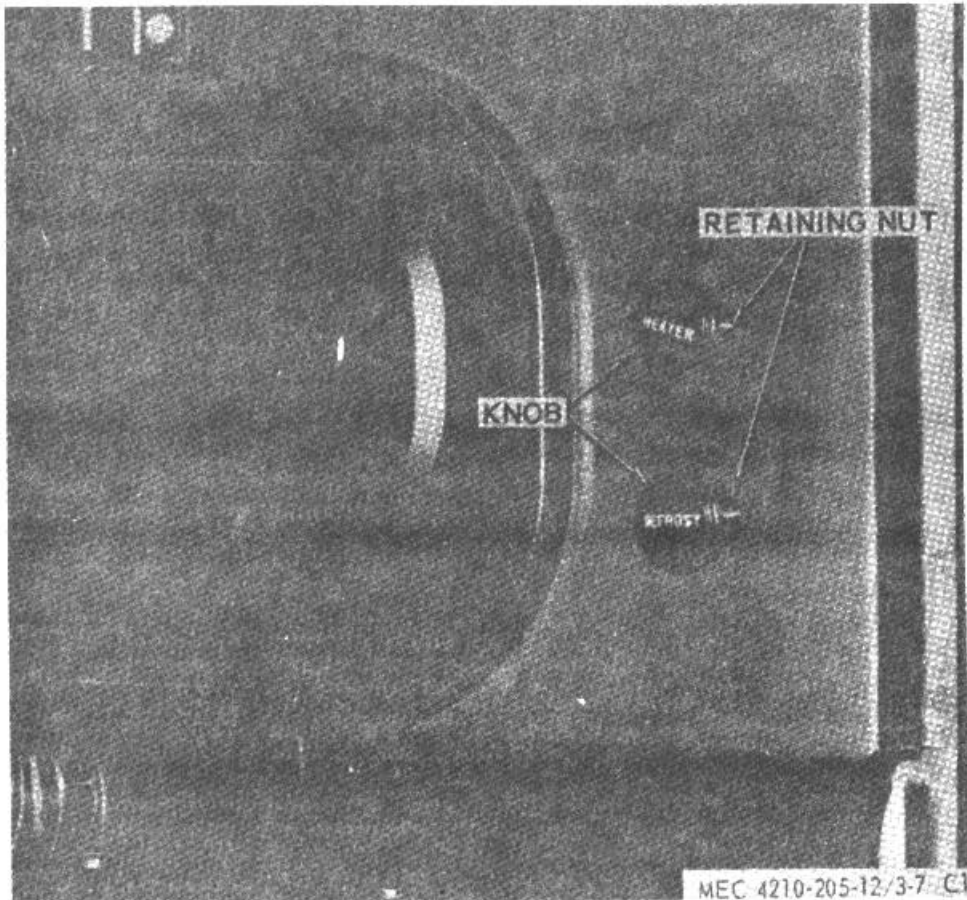

Figure 71.27. Personnel heater and defroster switch, removal and installation.

tube to cool. The switch should return to cold position at 200° to 300°F.

- (3) If a correctly adjusted switch does not meet these requirements, replace the flame switch.

d. *Flame Switch Installation.* To install the flame switch, position the switch in the control head; secure with the mounting nut. Connect the wiring as indicated in fig. 71.7.

188. Limit Switch

(fig. 71.25).

a. *Removal.* Disconnect the wires at the two limit switch terminals. Remove attaching screws, limit switch, and switch retainer.

b. *Installation.* Install in reverse of removal.

189. Circulating Pump Switch

(fig. 71.26).

a. *Removal.* Disconnect electrical leads from the switch. Remove retaining nut and switch.

b. *Installation.* Install in reverse of removal.

190. Personnel Heater Switch

(fig. 71.27).

a. *Removal.* Disconnect the electrical leads from the switch. Remove the knob and retaining nut. Remove the switch.

b. *Installation.* Install in reverse of removal.

191. Defroster Switch

(fig. 71.27).

a. *Removal.* Disconnect the electrical leads from the switch. Remove the knob and retaining nut. Remove the switch.

b. *Installation.* Install in reverse of removal.

192. Control Head Assembly (Liquid Heater)

(fig. 71.28).

Most of the parts of the control head assembly can be replaced by merely removing the cover and disconnecting the part. Refer to paragraph 194b if complete removal is required.

a. *Lower Delay.*

(1) The power relay controls the circuits to the fuel regulator valve, combustion blower motor, ignition system, and the nonfire relay. A defective power relay would affect operation of the heater beyond the preheating cycle.

(2) Remove the power relay (9, fig. 71.28) by pulling it from the socket (11).

(3) To test, apply nominal voltage to terminals 2 and 7 (fig. 1.7 for method of determining terminal numbers); the contacts should close immediately. Use an ohmmeter to check continuity between contacts 1 and 3, 4 and 5, and 6 and 8, when the relay is energized. Replace a faulty relay; do not attempt to adjust or repair it.

b. *Preheat and Nonfire Relays* (fig. 71.28). The preheat relay and the nonfire relay (3) are identical timing relays effective during different cycles of heater operation. Remove and test the relays as follows:

(1) Remove the control head cover. Depress and turn the shield (4), then lift off. Pull relay from the shield-type socket (2).

(2) To test the timing relay, apply proper voltage across terminals 1 and 2 and check continuity across terminals 6 and 9 (fig. 71.7 for method of determining terminal numbers). Within 30 to 60 seconds, the circuit through terminals 6 and 9 should open. Continuity should now be between terminals 4 and 6. Replace a faulty relay; do not attempt to adjust or repair it.

(3) Either relay can operate in either socket. If the operation of the preheat relay is suspected, interchange it with the nonfire relay and operate the heater. If ignition takes place, the relay originally in the preheat circuit is defective. If ignition does not take place, continue testing the relays and the other circuits.

c. *Ignition Coil Assembly* (fig. 71.28).

(1) If ignition troubles occur, inspect the ignition coil assembly (25) for a corroded high-tension terminal socket or a crazed high-tension cable. Test the coil with standard coil testing equipment, using voltage stamped in the coil case. If it is defective, replace the coil. Do not attempt to repair a faulty coil.

(2) To replace the ignition coil assembly (25), loosen the clamp that secures the shield (15) to the ignition coil, remove the shield, and disconnect the wires. Loosen the screw on the coil mounting clamp (16); remove the coil assembly. When

1 Screw	11 Socket	21 Connector
2 Socket	12 Spacer	22 Screw
8 Relay	13 Base	23 Screw
4 Shield	14 Nut	24 Grommet
5 Screw	15 Shield	25 Coil
6 Terminal block	16 Clamp	26 Nut
7 Resistor	17 Tee	27 Base assembly
8 Nut	18 Elbow	28 Grommet
9 Relay	19 Valve	29 Screw
10 Screw	20 Base	

Figure 71.28. Control head assembly.

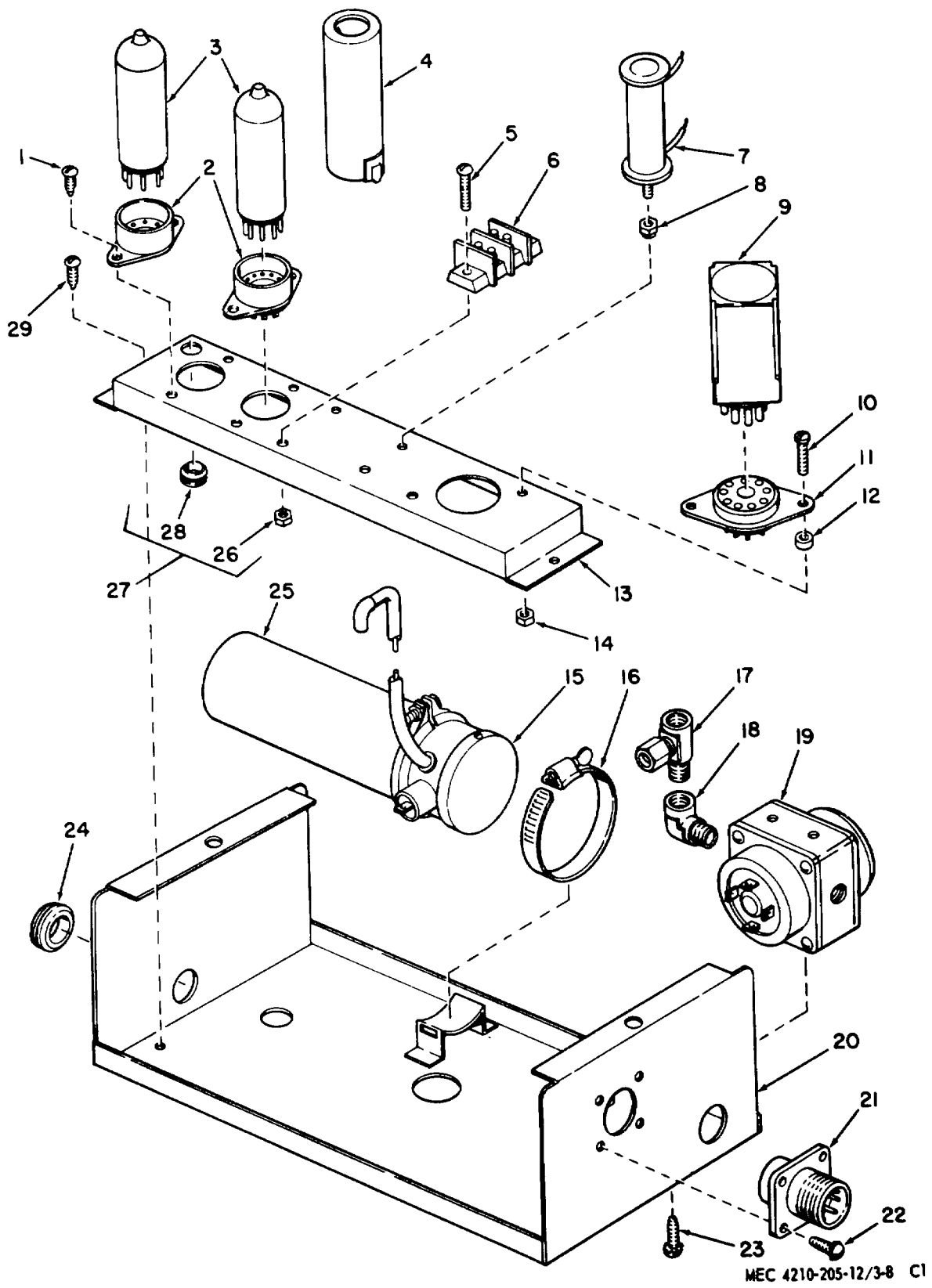

Figure 71.28--Continued.

installing the coil assembly, connect the wires as indicated in figure 71.7.

d. *Fuel Regulator Valve and Nozzle Assembly.* If faulty fuel regulator operation is suspected, remove the regulator valve and nozzle assembly and test for correct fuel flow:

- (1) Regulator Valve and Nozzle Assembly Removal.
 - (a) Remove the control head assembly (para 194b).
 - (b) Remove the adapter tee (17, fig. 71.28) and the elbow (18) from the fuel regulator valve. Remove the pipe plug (18, fig. 71.31) from the adapter tee and unscrew the nozzle assembly (19) from the tee.
 - (c) Disconnect the wires at the terminals of the regulator valve. Remove the two screws (23, fig. 71.28) fastening regulator valve (19) to the control head base (20).
- (2) Test Regulator Valve and Nozzle Assembly.
 - (a) Install a tee with pressure gage in the regulator valve outlet port. To this tee, install the adapter tee with the nozzle assembly. Connect a fuel supply capable of supplying a steady flow of fuel under constant pressure of 3 to 5 psig to the regulator valve inlet port. Connect the fuel tube (15, fig. 71.31) to the adapter tee, and make provisions to catch the fuel flow in a measuring graduate (approximately 50-100 ml).
 - (b) Connect a power supply of proper voltage to both sides of regulator valve and make provision to energize one or both sides of the valve.
 - (c) Operate the test setup to energize the shut-off valve (nameplate end) of the regulator valve and to supply fuel to the system. The fuel flow should be between 40 and 48 cc/min. at a pressure of 2 ± 0.2 psi. Break the circuit and the fuel flow should stop immediately.
 - (d) Connect both sides of the regulator valve to the power supply and note the fuel flow and pressure. The fuel

flow should be between 27 and 33 cc/min. at a pressure of 140.15 psi. Break the circuit and the fuel flow should stop immediately.

- (e) If outlet pressures do not conform to specification, or fuel flow does not stop when the circuit is broken, the fuel regulator valve is faulty and should be replaced.
 - (f) If outlet pressures do conform, but the fuel flow is lower than specified during tests, the nozzle assembly is clogged. Clean the passages of the nozzle assembly with compressed air only. Do not attempt to clean the fuel regulator with any type of instrument.
 - (g) If outlet pressures do conform, but fuel flow is higher than specified during tests, replace a faulty assembly.
- (3) Install Fuel Regulator Valve and Nozzle Assembly.
 - (a) Position the fuel regulator valve (19, fig. 71.28) on the control head base (20) and fasten with two screws (23). Connect wires as shown in wiring diagram (fig. 71.7.)
 - (b) Place the nozzle assembly (19, fig. 71.31) in the adapter tee (17, fig. 71.28) and insert pipe plug (18, fig. 71.31).
 - (c) Install the elbow (18, fig. 71.28) and the adapter tee on the outlet port of the fuel regulator valve.
 - (d) Attach the nut (16, fig. 71.81), sleeve (17), and fuel tube (15) to the adapter tee. Install the control head assembly (para 195k).

193. Control Head Assembly (Space Heater)

a. *Removal.* Refer to paragraph 192 (above) for removal procedures.

b. *Test Regulator Valve and Nozzle Assembly.*

- (1) Install a tee with the pressure gage in the regulator valve outlet port. To this

	Fuel Flow (cc/min.)	Pressure (psig)	Fuel Flow (cc/min.)	Pressure (psig)
Minimum	22		14.5	
Maximum	28	2±0.2	19.5	1±0.15

Figure 71.29. Fuel regulator valve test chart.

tee, install the adapter tee with nozzle assembly. Connect a fuel supply capable of supplying a steady flow of fuel under constant pressure of 3 to 5 psig to the regulator valve inlet port. Connect the fuel tube (13, fig. 71.35) to the tee and allow the fuel to flow into a measuring graduate (approximately 50-100 ml).

- (2) Connect the nominal voltage power supply to both sides of the regulator valve and make provision to energize one or both sides of the valve.
- (3) Operate the test setup to energize the shut-off valve (nameplate end) of the regulator valve and to supply fuel to the system. The fuel flow should be within the limits shown in the fuel regulator valve test chart below for the model heater tested. Break the circuit, and the fuel flow should stop immediately.
- (4) Connect both sides of the regulator valve to the power supply and note the fuel flow and pressure. The fuel flow and pressure should be within the limits shown in figure 71.29. Break the circuit, and the fuel flow should stop immediately.
- (5) If outlet pressures do not conform to specification or fuel flow does not stop during test, the fuel regulator valve is faulty and should be replaced.
- (6) If outlet pressures do conform but the fuel flow is lower than specified during tests, the nozzle assembly is clogged. Clean the passages of the nozzle assembly with air. Do not attempt to clean the regulator with any type of instrument.
- (7) If outlet pressures do conform, but the fuel flow is higher than specified during tests, replace a faulty nozzle assembly.

c. *Install Fuel Regulator Valve and nozzle assembly.*

- (1) Position the fuel regulator valve (19, fig. 71.28) on the control head base (20) and fasten with two screws (23). Connect wires as shown in the wiring diagram (fig. 71.12).
- (2) Install the nozzle assembly (19, fig. 71.35) in the adapter tee (17, fig. 71.28) and insert the pipe plug (18, fig. 71.35).
- (3) Install the elbow (18, fig. 71.28) and the tee on the outlet port of the fuel regulator valve.
- (4) Attach nut (16, fig. 71.35), sleeve (17) and fuel tube (15) to the adapter tee. Install the control head assembly.

194. Liquid Heater Disassembly

(fig. 71.30).

- a. *Removal.* Refer to figure 71.31 for removal.
- b. *Control Head Assembly Removal.*
 - (1) Remove two screws (12) from the control head cover (18) and lift cover.
 - (2) Disconnect ignition coil high-tension wire from the spark plug assembly. Disconnect both primary wires leading to the ignition coil.
 - (3) Loosen the fuel tube nuts (16) and remove the fuel tube (15) and sleeves (17).
 - (4) Disconnect at their terminal points the three wires extending through the grommet (48) in the heater casing. Unscrew the flame switch mounting nut.
 - (5) Remove the two wires from the limit switch (2) and disconnect the wire

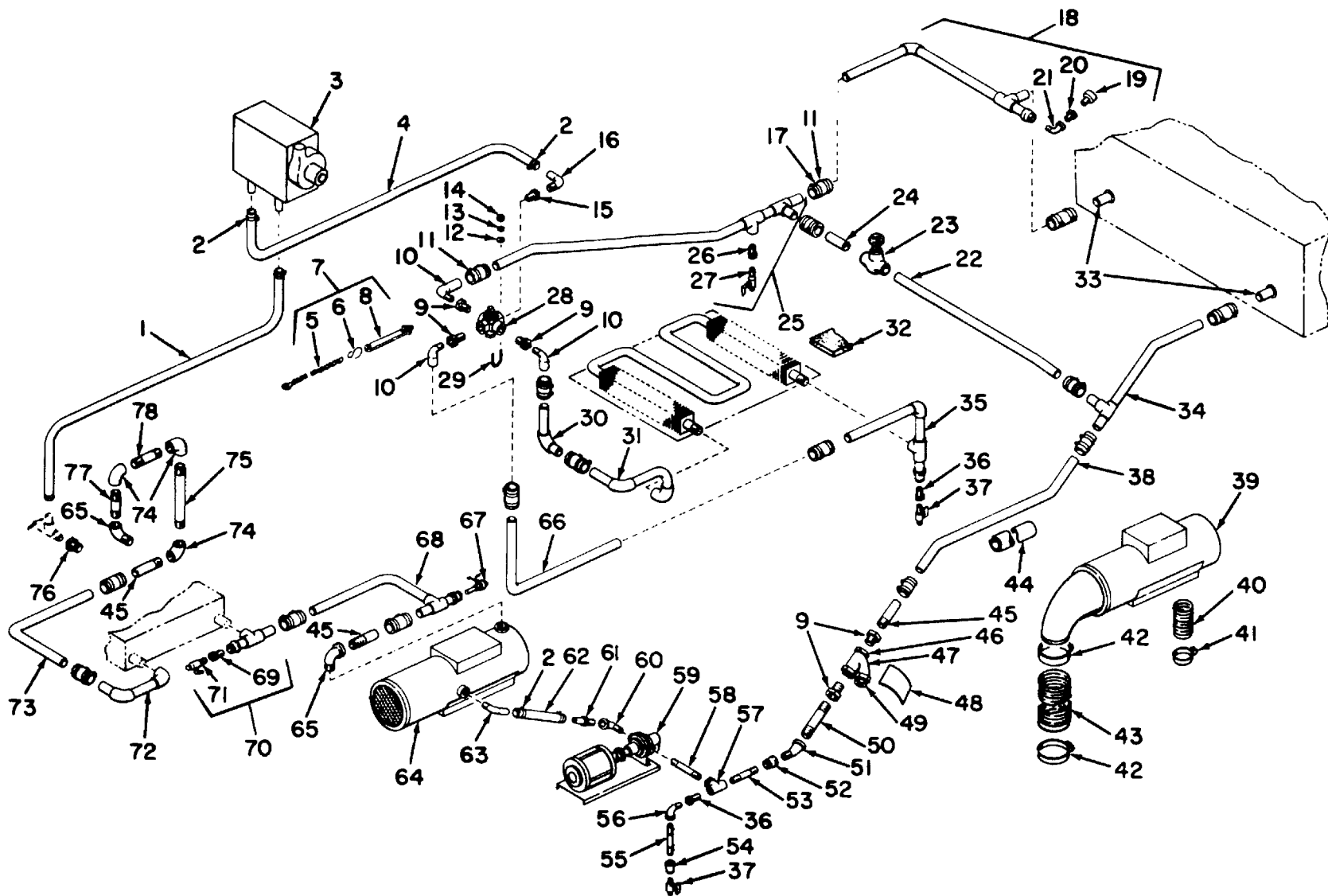

MEC 4210-205-12/3-10 C1

Figure 71.30. Liquid heating system.

1 Hose	21 Elbow	41 Clamp	60 Elbow
2 Clamp	22 Tube	42 Clamp	61 Adapter
8 Heater	23 Valve assembly	43 Hose	62 Hose
4 Hose	24 Tube	44 Insulation	63 Elbow
5 Chain	25 Tube assembly	45 Adapter	64 Coolant heater
6 Hook, S	26 Bushing	46 Strainer	65 Elbow
7 Handle installation	27 Cock	47 Element	66 Tube
8 Handle	28 Valve	48 Insulation	67 Switch
9 Bushing	29 Bolt, U	49 Plug	68 Tube assembly
10 Elbow	30 Elbow assembly	50 Nipple	69 Bushing
11 Clamp	31 Tube assembly	51 Elbow	70 Tee assembly
12 Washer	32 Insulation	52 Reducer	71 Cock
13 Washer	33 Tube	53 Nipple	72 Tube assembly
14 Nut	34 Tube assembly	54 Coupling	73 Tube
15 Bushing	35 Tube assembly	55 Nipple	74 Elbow
16 Elbow	36 Bushing	56 Elbow	75 Pipe
17 Hose	37 Cock	57 Tee	76 Bushing
18 Tube assembly	38 Tube	58 Nipple	77 Nipple
19 Valve	39 Space heater	59 Pump installation	78 Nipple
20 Bushing	40 Hose		

Figure 71.30--Continued.

which extends to the liquid circulating pump through the grommet (24, fig. 71.28) in the control head base.

- (6) Remove the screw (9, fig. 71.31) and the nut (20), and lift the control head assembly (21) and the flame switch assembly (11) from the casing and combustion chamber. When necessary to further disassemble the control head, see control head repair instructions in paragraphs 192 and 193.

c. Limit Switch Removal. Disconnect the wires at the two limit switch terminals. Remove two screws (4) fastening the limit switch (2) to the combustion chamber. Remove the switch retainer (3).

d. Casing Disassembly.

- (1) Remove the spark plug assembly (25), washer (26), and seal (27) from the burner.
- (2) Remove the two screws (76) attaching the heater mounting base assembly (75) to the casing and the combustion chamber. Remove the heater mounting base assembly and remove seal (62).
- (3) Remove the three screws (49) and the intake cover (52) from the casing (53).

- (4) Remove the four screws (50) attaching the casing to the combustion chamber (1).
- (5) Remove four screws joining the casing at the seam. Spread the casing and lift from the blower assembly (63), burner (28), and combustion chamber, withdrawing wire through the rubber grommet (48) in the casing.
- (6) Remove four nuts (65) fastening the combustion blower assembly (63) to the combustion chamber; remove the blower assembly.
- (7) Insert a screwdriver through the shell intake opening; loosen the setscrew (37) and remove the fan (38).
- (8) Disconnect the lead wire at the contact plate terminal. Remove the three screws (55) and the contact plate cap (54). Remove the screws and lock washers joining the contact plate assembly, motor, and shell. Remove the contact plate (42) and the two spacers (68); on the opposite end of the motor, remove the combustion air intake shell (77).
- (9) Remove screw (56), and remove the bushing (44), cam collar (43), and contact cam (67) from the motor shaft.

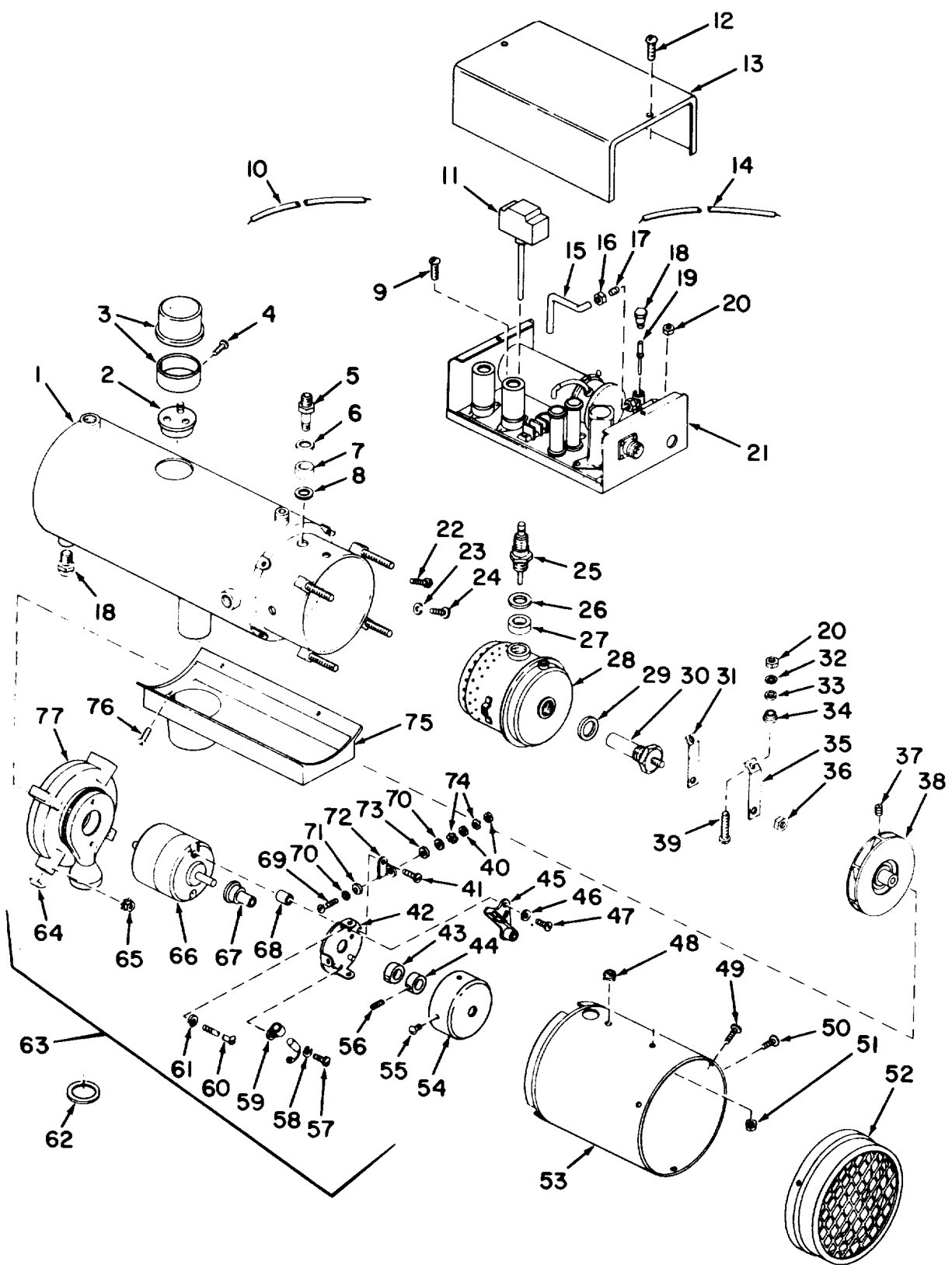

MEC 4210-205-12/3-11 CI

Figure 71.31. Liquid heater assembly.

1 Chamber	21 Head assembly	40 Nut	59 Bracket
2 Switch	22 Screw	41 Screw	60 Screw
8 Retainer	23 Washer	42 Plate	61 Washer
4 Screw	24 Screw	43 Collar	62 Seal
5 Union	25 Spark plug	44 Bushing	63 Blower assembly
6 Washer	26 Washer	45 Contact set	64 Bumper
7 Seal	27 Seal	46 Washer	65 Nut
8 Gasket	28 Burner	47 Screw	66 Motor
9 Screw	29 Gasket	48 Grommet	67 Cam
10 Lead	30 Preheater	49 Screw	68 Spacer
11 Lead	31 Insulator	50 Screw	69 Screw
12 Screw	32 Washer	51 Nut	70 Washer
13 Cover	33 Insulator	52 Cover	71 Insulator
14 Lead	34 Insulator	53 Casing	72 Bracket
15 Tube	35 Band	54 Cap	73 Insulator
16 Nut	36 Nut	55 Screw	74 Washer
17 Sleeve	37 Setscrew	56 Setscrew	75 Base
18 Plug	38 Fan	57 Screw	76 Screw
19 Nozzle	39 Screw	58 Washer	77 Shell
20 Nut			

Figure 71.31-Continued.

- (10) To remove the burner assembly from the combustion chamber, remove the union (5), union seal washer (6), union seal (7), and gasket (8) extending from the burner fuel feed connector. Remove the insulator washer (32), insulator washer (33), post insulator (34), connector band (35), and screw (39) from the combustion chamber.
- (11) Remove the nut (20), lead washer (24) and washer (23) from each side of the combustion chamber; then remove the burner (28).
- (12) The preheater (30) is threaded to the burner; unscrew to remove the preheater and gasket (29). Remove the preheater nut (36) to remove the connector band (35) from the preheater.
- e. *Cleaning and Inspection of Burner Parts.*
- (1) Use a cloth dampened with solvent, and dry, compressed air to clean accumulated dirt from all heater parts. Scrape carbon deposits and other foreign materials caused by combustion, being careful to avoid damaging the ceramic wick. Clean air ports thoroughly to remove all accumulations of carbon, or restrictions.
 - (2) Inspect burner and blower parts, combustion chamber, and casing for cracked, burned, dented or otherwise damaged condition. Replace faulty parts.
 - f. *Blower Motor Test.* Reassemble the blower assembly to test the motors. Connect a power supply of proper voltage to the assembly and operate the motor. Check motor speed with a stroboscope. The motor speed should be a minimum of 6,500 rpm. Replace this motor if it does not meet this requirement.
 - g. *Contact Plate Assembly.*
 - (1) Inspect Contact Set. Disassemble the heater to provide access to the contact plate. Clean the contacts with fine sandpaper. If the contacts are burned or deeply pitted and are difficult to clean, replace both the contact set and the capacitor, since the capacitor probably caused the faulty contact condition. Adjust contact as described in paragraph (3) below.
 - (2) Replace Contact Set and Capacitor.
 - (a) Loosen the terminal nuts (40, fig. 71.31) and disengage the capacitor lead wire from the terminal. Remove the capacitor mounting screw (57) and washer (58) and remove the capacitor bracket (59)

and capacitor.

- (b) Disengage the contact spring from the terminal screw (69), and lift the movable (top) contact from the pivot pin. Remove the screw (47) and washer (46), and then remove the adjustable (bottom) contact from the pivot pin.

Note

Be sure to place the rubbing block of the movable contact between the two teeth on the brass cam collar.

- (c) Secure the capacitor to the contact plate with the capacitor bracket (59), screw (57) and washer (58). Engage the capacitor lead wire with the terminal between the contact spring and brass washer. Tighten the terminal nuts (40).
- (3) Contact Plate Gap Adjustment (fig. 71.32).
 - (a) With the cam and contact plate assembled to the motor, rotate the motor shaft until the movable contact is at the high point of the cam. Make sure the rubbing block of the movable contact is between the teeth of the cam collar. At this position, an 0.025-in. feeler gage should just pass between the contacts

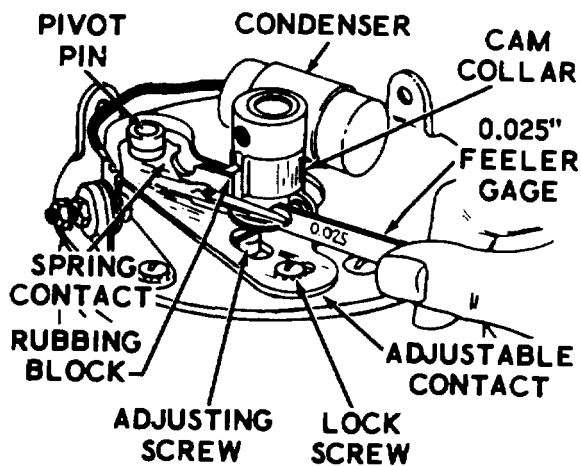

MEC 4210-205-12/3-12 C1

Figure 71.32. Adjusting the contact plate point gap.

- (b) If the gap needs adjusting, loosen the adjustable contact mounting screw and position the stationary contact to correct the contact gap. Tighten the mounting screw.

- (4) Contact Plate Reassembly. Install contact plate on the blower motor as instructed in *h* (6) below.

h. Blower, Burner, and Combustion Chamber Reassembly.

- (1) To assemble the blower, burner, and the combustion chamber, position the gasket (29, fig. 71.31) on the preheater (30), and screw the heater onto the burner assembly (28).
- (2) Insert the post insulator (34) into the opening on the combustion chamber. Attach the connector band (35) to the post insulator with a brass screw (39) inserted from inside the combustion chamber. Position the insulator washer (33), flat washer (32), and control head lead on the screw; secure with a nut (20).
- (3) Insert the burner assembly into the combustion chamber (1). Align the burner brackets with the screw holes in the combustion chamber sides, and fasten with two screws (24) and washers (23), holding the burner in place against the throat of the combustion chamber. Secure the connector band (35) to the terminal of the preheater (30) with the preheater nut (36).
- (4) Install the gasket (8), union seal (7), union seal washer (6), and union (5) on burner fuel feed connector.
- (5) Apply several drops of light oil on the cam collar (43). Position the cam collar and the cam bushing (44) on the contact cam (67). Align the holes of the contact cam and the cam bushing, and install the setscrew (56) just far enough to hold the parts together. Position the cam assembly on the motor shaft so that the setscrew is aligned with the flat on the motor shaft, and tighten the setscrew. Make sure that some clearance exists

between the motor and the cam assembly.

- (6) Insert the screws and lock washers through the contact plate (42), and place the spacers (68) on threaded end of the screws. Insert the screws straight through motor (66). Make sure the teeth of the cam collar (43) engage the rubbing block of the movable contact. Position the shell assembly (77) on the opposite end of motor, and attach with the two screws inserted through the motor into the tapped holes of the shell.
- (7) Install the contact plate cap (54) over the cam assembly and the contact plate assembly, and fasten with three screws (55). Connect the lead wire from the ignition coil to the contact plate terminal.
- (8) Place the fan (38) on the motor shaft and adjust the mounting position to allow approximately 1 6-inch clearance between shell and fan. Tighten setscrew (37) with a screwdriver inserted through the shell intake opening to secure fan to motor shaft. Make sure the setscrew is aligned with the flat on the motor shaft.
- (9) Position the combustion air blower assembly (63) on four combustion chamber studs. Apply a coat of "Permatex Form-A-Gasket, Aviation Grade No. 3" for sealing. Fasten with the four nuts (65). Rotate motor shaft slowly to make certain the fan does not hit any stationary parts.

i. Casing Reassembly.

- (1) Place the casing (53) over the assembled blower, burner, and combustion chamber, passing the three lead wires through the grommet (48). Fasten together the edges of the casing with screws.
- (2) Fasten the casing to the combustion chamber with four screws (50). Install the combustion air seal (62) on the intake port of the blower shell.

- (3) Install intake cover (52) and fasten with three screws (49).
- (4) Position the heater mounting base assembly (75) on the casing and the combustion chamber, and fasten to the casing with two screws (76).
- (5) Install the seal (27), washer (26), and spark plug (25) on the burner.

j. Limit Switch Installation. Position the limit switch (2) on the combustion chamber. Place the switch retainer (3) on the switch and fasten to the weld nuts on the combustion chamber with two screws (4). Connect the lead wires to the switch.

k. Control Head Installation.

- (1) Position the control head assembly (21) on the heater, and fasten to the casing with the screw (9) and to the combustion chamber stud with the nut (20).
- (2) Insert the tube of the flame switch (11) into the flame switch support tube of the combustion chamber and tighten the mounting nut. Connect the wires as indicated in the wiring diagram (fig. 71.7).
- (3) Connect the fuel tube (15, fig. 71.31) to the metering tee and union with sleeves (17) and nuts (16).
- (4) Connect the primary lead wires of the coil shield and connect the high-tension wire to the spark plug, as indicated in the wiring diagram (fig. 71.7).
- (5) Install the cover (18, fig. 71.31) and fasten with the two screws (12).

195. Personnel Heater

(fig. 71.33).

a. Removal. Disconnect the electrical leads. Remove the defroster hose and liquid hoses. Remove attaching hardware and lift the heater out of the cab.

b. Installation. Install in reverse of removal.

196. Defroster Blower

(fig. 71.33).

a. Removal. Remove the defroster hose and disconnect the electrical lead at the blower. Re

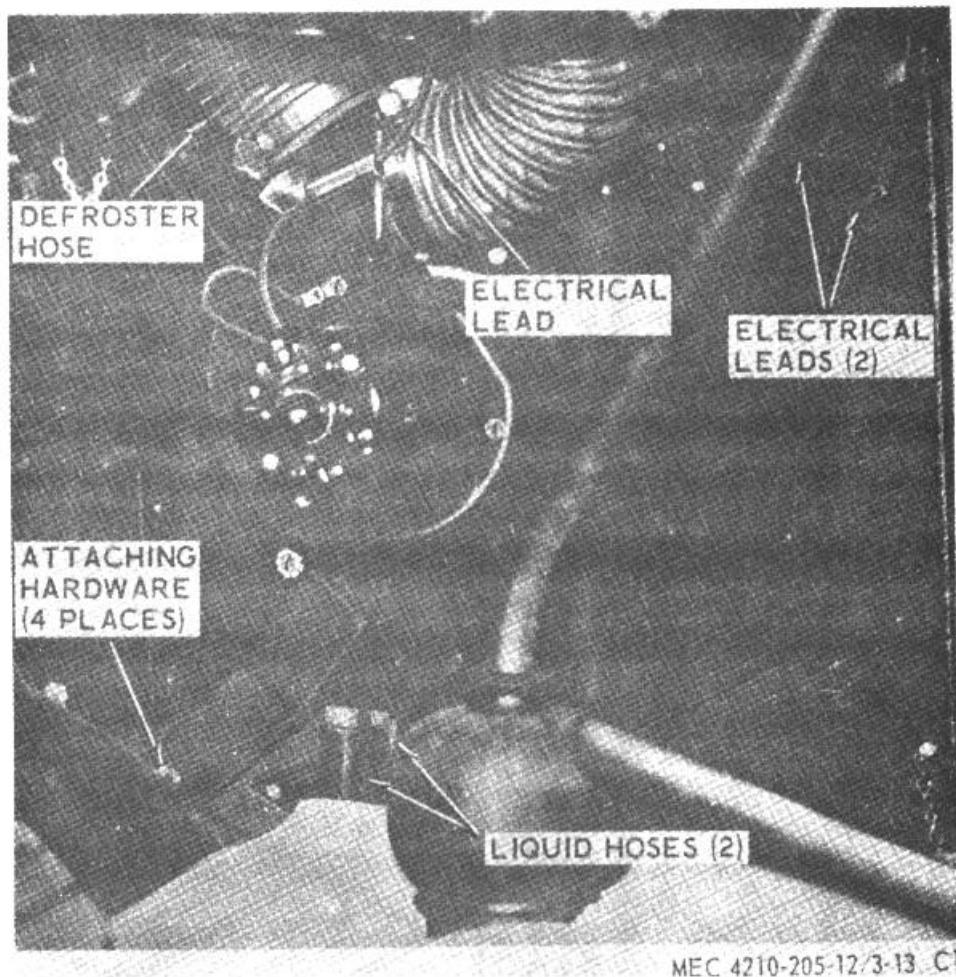

Figure 71.33. Personnel heater and defroster.

move the blower motor to expose the blower attaching hardware. Remove the blower.

b. Installation. Install in reverse of removal.

197. Space Heater

Repair procedures for the space heater are similar to the procedures described in paragraph 194 with the following exceptions. Refer to figure 71.12 for electrical schematic.

a. Removal. (fig. 71.34). Disconnect electrical leads and the flexible tubing from the space heater assembly. Remove attaching hardware and the space heater.

b. Circulating Air Blower Removal and Disassembly.

- (1) Remove the three screws (50, fig. 71.35) and the intake cover (48) from the casing. After removing the three screws (50), remove the circulating air blower assembly (49) from the casing. Withdraw the wire through the rubber grommet (23) in the casing during removal. If the control head has not been removed, disconnect the wire at its terminal in the control head.
- (2) Loosen the setscrew (45) and remove the fan (52) from the motor shaft. Insert a screwdriver through the motor clamp assembly to loosen clamp screw (46).

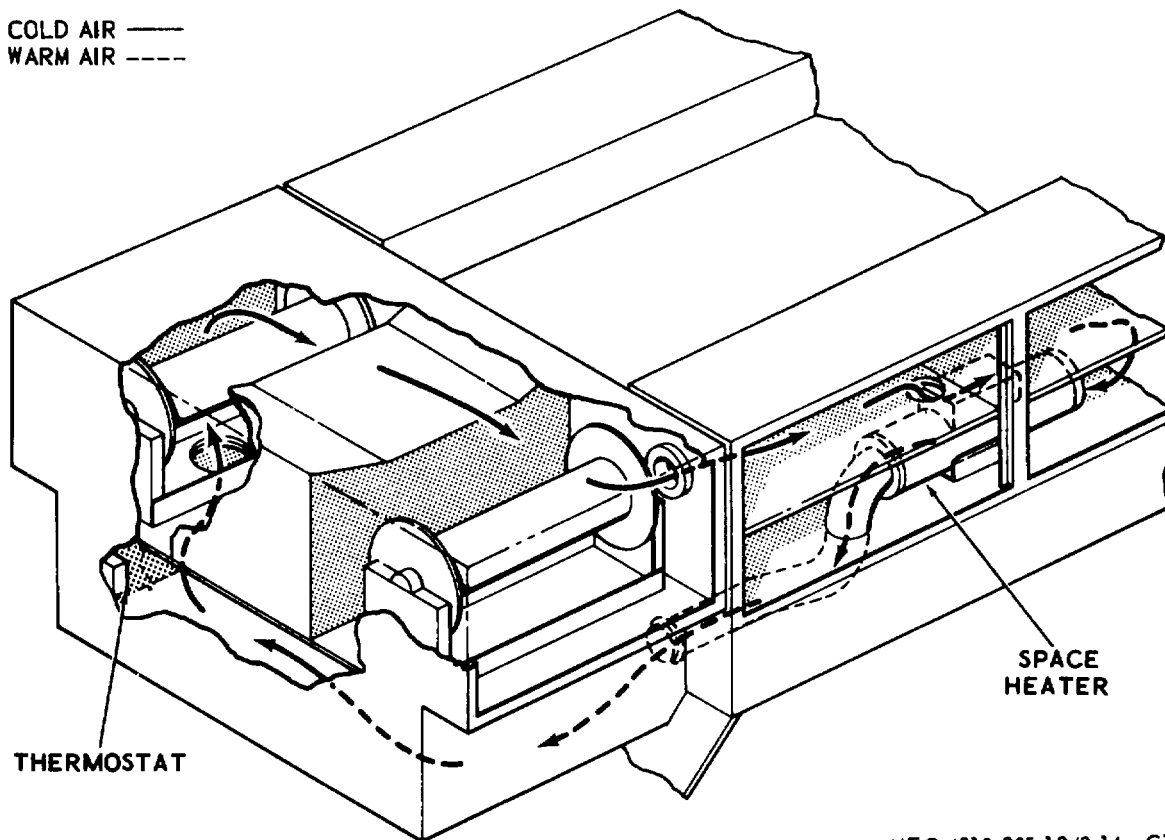

MEC 4210-205-12/3-14 C1

Figure 71.34. Space heating system.

Remove the motor (47) from the motor clamp (51).

c. Casing Disassembly.

- (1) Remove the spark plug assembly (6), spark plug seal washer (7), and spark plug seal (8) from the burner.
- (2) Remove the four screws (79) attaching the heater mounting base assembly (80) to the casing; remove the base assembly.
- (3) Remove the seals (81) from the combustion air ports, and the five screws (24) fastening the casing assembly (1). Spread the casing apart at the joint and remove the combustion air blower assembly (63), burner (40), and combustion chamber (26) as an assembly. Withdraw the wires through the grommets (23) and (9) in the casing during the removal.

d. Contact Plate. Refer to paragraph 194g.

e. Blower Motor Test. Reassemble the blower assembly to test the motors. Connect a 24 vdc power supply to the assembly and operate the motor. Check the motor speed with a stroboscope. Minimum speed allowed is: 5,000 rpm, circulating motor; 6,500 rpm, combustion motor.

f. Blower, Burner and Combustion Chamber Reassembly.

- (1) To assemble the blower, burner, and combustion chamber, insert the burner assembly (40, fig. 71.35) into the combustion chamber. Align the burner brackets with the screw holes in the combustion chamber sides and fasten in place with two washers (31) and screws (32), being careful to hold the burner in place against the throat of the combustion chamber.

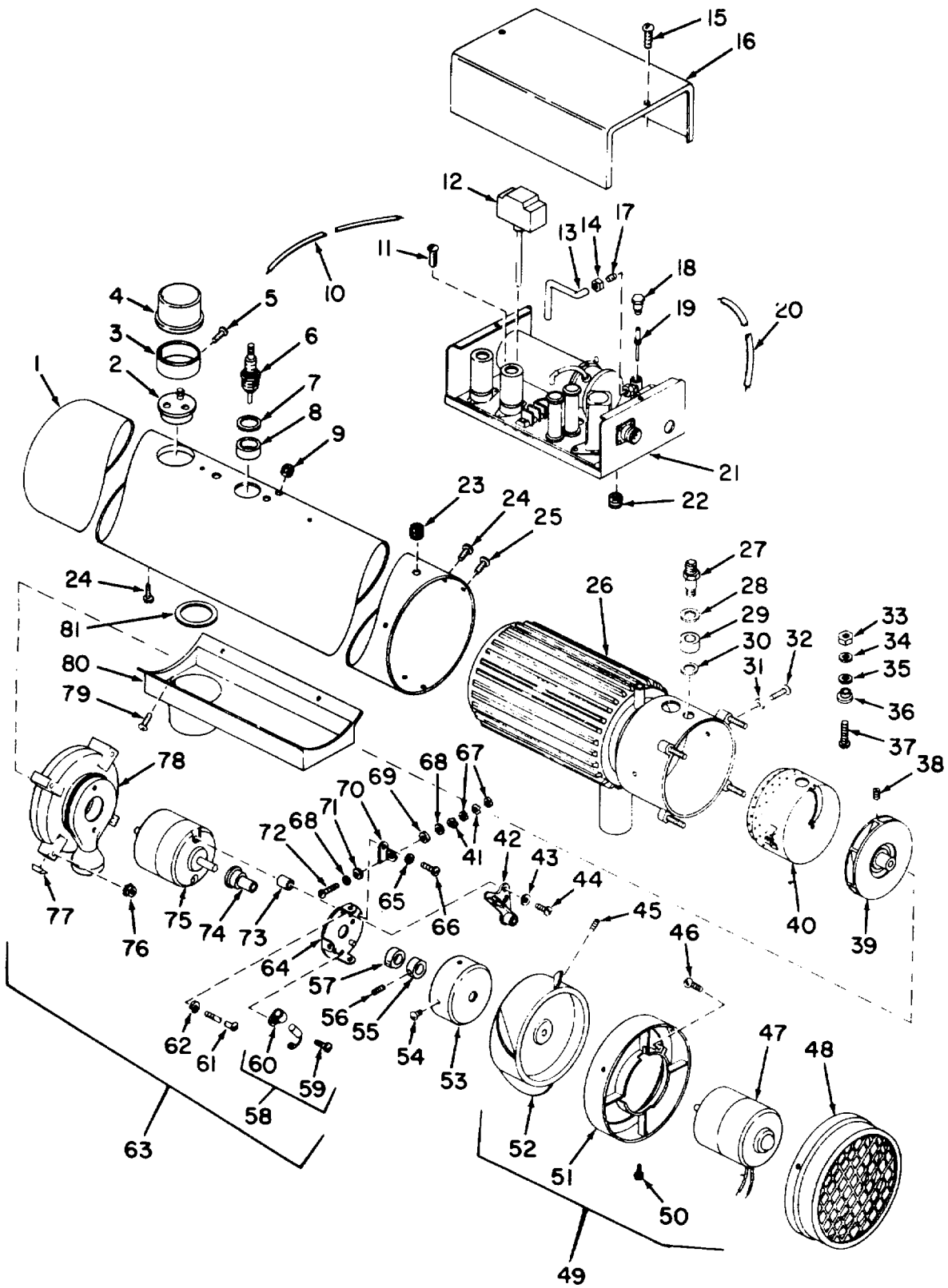

MEC 4210-205-12/3-15 CI

Figure 71.35. Space heater assembly.

1	Casing	22	Grommet	43	Washer	62	Washer
2	Switch	23	Grommet	44	Screw	63	Blower assembly
3	Retainer	24	Screw	45	Setscrew	64	Plate
4	Cap	25	Screw	46	Screw	65	Washer
5	Screw	26	Chamber	47	Motor	66	Screw
6	Spark plug	27	Union	48	Cover	67	Nut
7	Washer	28	Washer	49	Blower assembly	68	Washer
8	Seal	29	Seal	50	Screw	69	Insulator
9	Grommet	30	Gasket	51	Clamp assembly	70	Bracket
10	Lead	31	Washer	52	Fan	71	Insulator
11	Screw	32	Screw	53	Cap	72	Screw
12	Switch	33	Nut	54	Screw	73	Spacer
13	Tube	34	Washer	55	Bushing	74	Cam
14	Nut	35	Insulator	56	Setscrew	75	Motor
15	Screw	36	Insulator	57	Collar	76	Nut
16	Cover	37	Screw	58	Capacitor and bracket	77	Bumper
17	Sleeve	38	Screw	59	Screw	78	Shell
18	Plug	39	Fan	60	Bracket	79	Screw
19	Nozzle	40	Burner	61	Screw	80	Base
20	Lead	41	Washer			81	Seal
21	Head assembly	42	Contact set				

Figure 71.35-Continued

- (2) Attach the preheater lead of burner to the post insulator (36) with the brass screw (37) inserted from inside the combustion chamber assembly (26). Attach the insulator washer (35), flat washer (34), and nut (33) to the screw and tighten.
- (3) Install the gasket (30), union seal (29), union seal washer (28), and union (27) on the burner fuel feed connector.
- (4) Apply several drops of light oil on the cam collar (57). Position the cam collar and the cam bushing (55) on the contact cam (74). Align the holes of the contact cam and the cam bushing and install the setscrew (56) just far enough to hold the parts together. Position the cam assembly on the motor shaft so that the setscrew is aligned with the flat on the motor shaft. Tighten the setscrew. Make sure that some clearance exists between the motor and the cam.
- (5) Insert the screws (61) and lockwashers (62) through the contact plate (64) and place the spacers (73) on the threaded end of the screws. Insert the screws straight through the motor
- (75). Make sure that the teeth of the cam collar (57) engage the rubbing block of the movable contact. Position the combustion air shell assembly (78) on the opposite end of the motor and attach by turning the two screws inserted through the motor into the tapped holes of the shell.
- (6) Install the contact plate cap (53) over the contact plate assembly and fasten with three screws (54).
- (7) Place the fan assembly (39) on the motor shaft and adjust the mounting position to allow approximately 1-16 inch clearance between the shell and the fan. Tighten the special screw (38) with a screwdriver inserted through the shell intake opening to secure the fan to the motor shaft. Make sure the special screw is aligned with the flat of the motor shaft.
- (8) Position the combustion air blower assembly (63) on the four combustion chamber studs. Apply a coat of "Permatex Form-A-Gasket, Aviation Grade No. 3" for sealing; fasten with nuts (76). Rotate motor shaft slowly to check for free rotation.

g. Casing Reassembly.

- (1) Spread the casing (1); install the assembled combustion blower, burner, and combustion chamber into the casing, passing the lead wires from the preheater, ignition coil, and the combustion blower motor through the grommet. Connect the lead from the ignition coil to the terminal on the contact plate (64).
- (2) Install the exhaust tube seals (81) around the combustion air ports and fasten together the edges of the casing with screws (24). Install the spark plug seal (8), spark plug seal washer (7), and the spark plug assembly (6) into the burner.
- (3) Position the heater mounting base assembly (80) at the bottom of the casing and fasten with four screws (79).

h. Circulating Air Blower Reassembly.

- (1) Place the motor (47) within the motor clamp assembly (51), allowing the front of the motor to extend approximately 1/16-inch beyond the clamp assembly. Insert a screwdriver through the clamp shell to tighten the screw (46).
- (2) Place the fan (52) on the motor shaft and adjust the mounting position to allow approximately 1/16-inch clearance between the fan and motor hub. Tighten the setscrew (45) to secure the fan to shaft.
- (3) Rotate the motor shaft to check for free rotation.
- (4) Insert the circulating air blower assembly (49) through air intake, first passing the lead wire through the grommet (23). Fasten the assembly to the casing with three screws (50).

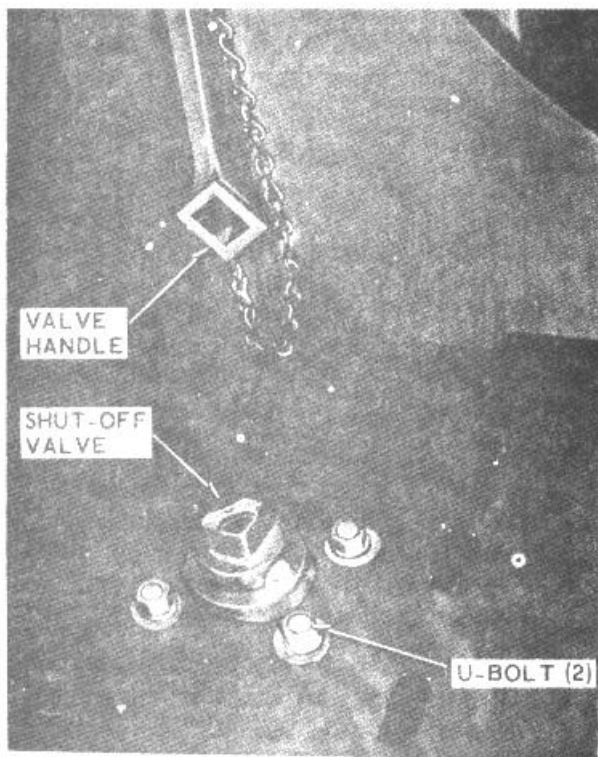

MEC 4210-205-12-3-16 CI

Figure 71.36. Battery compartment shut-off valve.

198. Battery Box

Refer to TM 5-4210-205-12 for repair procedures.

199. Battery Compartment Shut-off Valve

- a. *Removal.* Disconnect all liquid lines at the valve. Remove the two U-bolts and the valve.
- b. *Installation.* Install in reverse of removal.

200. Liquid Circulating Pump

- a. *Removal.* Remove nipple (58, fig. 71.30) and elbow (60) from the pump assembly. Remove coupling from the pump shaft. Remove attaching parts and the pump.
- b. *Installation.* Install in reverse of removal.

201. Fuel Pump

a. Fuel Pump Test.

- (1) With the fuel pump assembled, connect a power supply of proper voltage to the fuel pump, making sure to check for proper polarity. Connect a fuel supply to the fuel pump. Connect a liquid pressure gage to the output port and operate the pump. Observe the fuel discharge pressure. The pump should discharge at 3 to 5 psig.

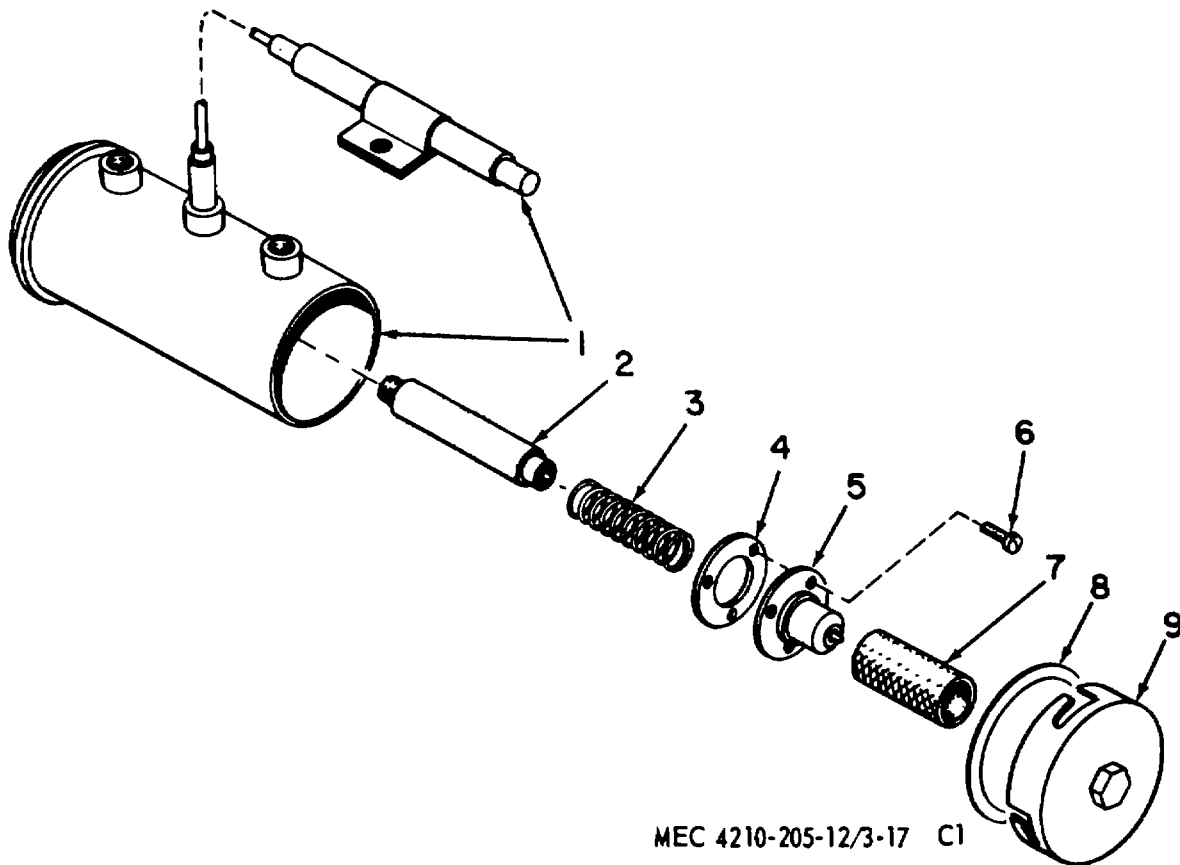

MEC 4210-205-12/3-17 C1

- | | | |
|-----------------|----------|------------------|
| 1 Pump assembly | 4 Gasket | 7 Screen |
| 2 Plunger | 5 Cup | 8 Gasket |
| 3 Spring | 6 Screw | 9 Cover assembly |

Figure 71.37. Fuel pump assembly.

(2) If the pump does not operate satisfactorily, disassemble, and inspect the screen (7) for clogging. If the screen is clean and the pump does not operate satisfactorily, replace the pump assembly.

b. Fuel Pump Disassembly.

(1) Give the cover (9) one-quarter turn counterclockwise, using a wrench on the cover nut to remove it from the bottom of the pump. Carefully remove the screen (7).

(2) If further pump disassembly is required, remove screws (6); lift out the cup (5), gasket (4), spring (8), and the plunger assembly (2). Do not dis-

assemble the plunger assembly or the pump assembly.

c. Cleaning and Inspection.

(1) Immerse the screen (7) and the cover (9) in cleaning solvent; flush carefully.

(2) Clean dirt and dust particles from other pump parts, using dry, compressed air, carefully applied.

(3) Check the screen (7) for distortion and damage.

(4) Check all the parts for cracks, distortion, signs of overheating, and damaged threads.

d. Fuel Pump Reassembly.

(1) Insert the plunger assembly (2) in the pump assembly (1). Check the fit

of the plunger by slowly raising and lowering the plunger (2) in the pump cylinder. The plunger assembly should move freely without binding or sticking. A click will be heard each time the plunger approaches the top of the cylinder. This indicates that the pump interrupter system is operating properly.

- (2) Insert the spring (3), gasket (4), and cup (5) into the housing; secure with the screws.
- (3) Place the gasket (4) on the cover and seat the screen (7) in the cover. Assemble these parts to the pump, being careful to guide the screen around the cup. Use a wrench on the cover nut and turn the cover one-quarter

turn clockwise to secure it to the housing.

202. Fuel Filter

- a. *Removal.* Disconnect the three-inch tube (fig. 71.6) from the elbow. Remove the fuel filter from the pipe connecting the filter to the fuel pump.
- b. *Repair.* Repair of the fuel filter is limited to replacement of the element and gasket.
- c. *Installation.* Install in reverse of removal.

203. Fuel Lines and Fittings

- a. *Removal.* Refer to figure 71.6 for removal sequence of the fuel lines and fittings.
- b. *Installation.* Install in reverse of removal.

Section VII. ELECTRIC MOTORS AND GENERATORS

204. Motor-Generator Assembly

- a. *Removal.* Remove components of the motor-generator assembly in the sequence shown in figure 71.38.
- b. *Repair.* Repair of the applicable components is limited to replacement of defective parts.
- c. *Installation.* Install in reverse of removal.

205. Components Drive Coupling

- a. *Removal.* Remove either the electric motor (35, figure 71.38) or the generator (83). Slide the coupling (34) from the shafts of the electric motor and the generator.

206. Circuit Breaker

Refer to figure 71.38 for removal sequence.

- a. *Removal.* Refer to figure 71.38 for removal sequence.
- b. *Installation.* Install in reverse of removal.

207. Voltage Regulator

- a. *Removal.* Refer to figure 71.38 for removal sequence.
- b. *Installation.* Install in reverse of removal.

208. Reverse Current Relay

- a. *Removal.* Refer to figure 71.38 for removal sequence.
- b. *Installation.* Install in reverse of removal.

1 Relay assembly	13 Washer	25 Connector	36 Washer
2 Enclosure	14 Screw	26 Junction box	37 Nut
8 Relay	15 Base	27 Washer	88 Cable
4 Lead	16 Adapter	28 Nut	89 .Regulator
5 Circuit breaker	17 Connector	29 Cable	40 Connector
6 Lead	18 Cable	80 Screw	-41 Loom
7 Clamp	19 Cable assembly	81 Clamp	42 Lead
8 Connector	20 Connector	82 Connector	48 Lead
9 Terminal	21 Screw	88 Generator	44 Loom
10 Nut	22 Gasket	84 Coupling	45 Connector
11 Washer	28 Cover	85 Motor	46 Screw
12 Screw	24 Gasket		

Figure 71.38. Motor-generator set.

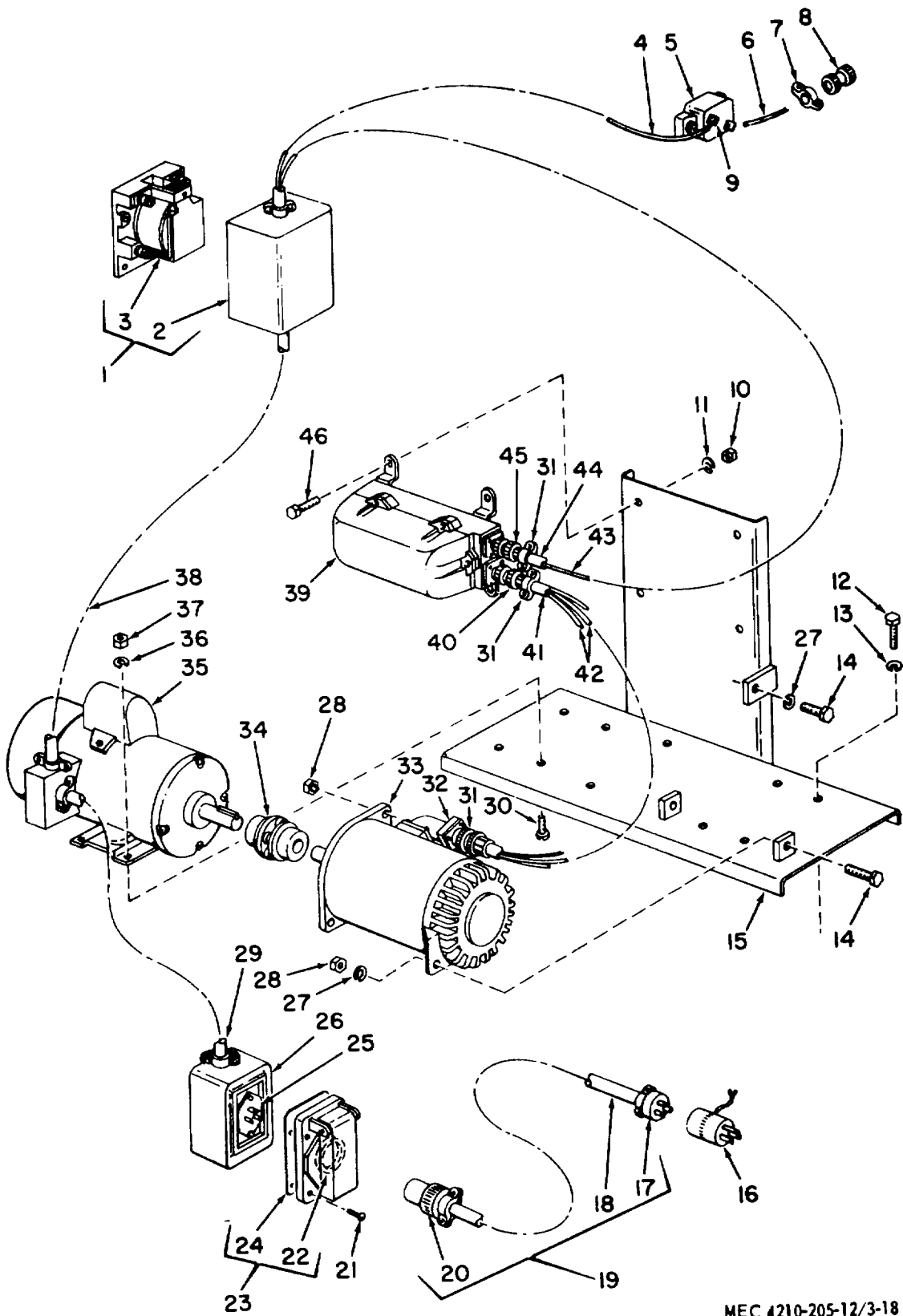

MEC 4210-205-12/3-18 C1

Figure 71.38-Continued

**APPENDIX II
MAINTENANCE ALLOCATION CHART**

Section I. INTRODUCTION

1. General

a. *Section I* provides a general explanation of all maintenance and repair functions authorized at various maintenance levels.

b. *Section II* designates overall responsibility for the performance of maintenance operations on the identified end item or component. The implementation of the maintenance tasks upon the end item or component will be consistent with the assigned maintenance operations.

2. Explanation of Columns In Section II

a. *Functional Group Number.* The functional group is a numerical group set up on a functional basis. The applicable functional grouping indexes (obtained from TB 750-93-1, Functional Grouping Codes) are listed on the MAC in the appropriate numerical sequence. These indexes are normally set up in accordance with their function and proximity to each other.

b. *Component Assembly Nomenclature.* This column contains a brief description of the components of each functional group.

c. *Maintenance Operations and Maintenance Levels.* This column list the various maintenance operations (A through J) and indicates the lowest maintenance level authorized to perform these operations.

The symbol designations for the various maintenance levels are as follows:

- C--Operator or crew
- O--Organizational maintenance
- F--Direct support maintenance
- H--General support maintenance
- D--Depot maintenance

The Maintenance Operations are defined as follows:

A -SERVICE: Operations required periodically to keep the item in proper operating

condition, i.e., to clean, preserve, drain, paint, and replenish fuel, lubricants, hydraulic, and deicing fluids, or compressed air supplies.

B—ADJUST: Regulate periodically to prevent malfunction. Adjustments will be made commensurate with adjustment procedures and associated equipment specifications.

C—ALINE: Adjust two or more components of an electrical or mechanical system so that their functions are properly synchronized or adjusted.

D—CALIBRATE: Determine, check, or rectify the graduation of an instrument, weapon, or weapons system or components of a weapons system.

E—INSPECT: Verify serviceability and detect incipient electrical or mechanical failure by close visual examination.

F—TEST: Verify serviceability and detect incipient electrical or mechanical failure by measuring the mechanical or electrical characteristics of the item and comparing those characteristics with authorized standards. Tests will be made commensurate with test procedures and with calibrated tools and/or test equipment referenced in the MAC.

G—REPLACE: Substitute serviceable components, assemblies and subassemblies for unserviceable counterparts or remove and install the same item when required for the performance of other maintenance operations.

H—REPAIR : Restore to a serviceable condition by replacing unserviceable parts or by any other action required using available tools, equipment and skills-to include welding, grinding, riveting, straightening, adjusting and facing.

I—OVERHAUL: Restore an item to a completely serviceable condition (as prescribed by serviceability standards developed and published by the commodity commands) by employing techniques of "Inspect and Repair Only as Necessary" (IROAN). Maximum use of diagnostic and test equipment is combined with minimum disassembly during overhaul. "Overhaul" may be assigned to any level of maintenance except organizational, provided the time, tools, equipment, repair parts authorization, and technical skills are available at that level.

Normally, overhaul as applied to end items, is limited to depot maintenance level.

J—REBUILD: Restore to a condition comparable to new by disassembling to determine the condition of each component part and reassembling using serviceable, rebuilt, or new assemblies, subassemblies, and part.

c. *Reference Note.* This column, subdivided into columns K and L, is provided for referencing the SPECIAL TOOL AND TEST EQUIPMENT REQUIREMENTS and REMARKS that may be associated with maintenance operations (sec. II).

Section II. MAINTENANCE ALLOCATION CHART

F U N C. G R O U P N O.	C O M P O N E N T A S S E M B L Y N O M E N C L A T U R E	E S S E N T I A L I T Y											NOTE REF.			
			A	B	C	D	E	F	G	H	I	J	K	L		
			S E R V I C E	A D J U S T	A L I N E	C A L I B R A T E	I N S P E C T	T E S T	R E P L A C E	R E P A I R	O V E R H A U L	R E B U I L D	T & T E R Q M T	R E M A R K S		
03	FUEL SYSTEM															
0312	Throttle Controls															
	Controls, Throttle															
06	ELECTRICAL SYSTEM															
0607	Instrument or Engine Control Panel Switches; gages; hour-meter; box, instrument housing; tachometer; lamp holder; bulb; panel															
	Cable assembly wiring															
0608	Miscellaneous Items															
	Receptacle, slave; switch, turn signal															
0609	Lights															
	Lights; Lens; doors; gaskets															
	Light, rotating															
0611	Siren															
	Siren															
	Switch															
0612	Batteries															
	Box, battery															
0613	Chassis Wiring Harness															
	Harness, wiring															
0615	Radio Interference Suppression															
	Component															
12	BRAKES															
1208	Air Brake System															
	Fitting															
	Tubing															
18	BODY															
1808	Hose Reels															
	Reels, hose	C														

F U N C. G R O U P N O.	C O M P O N E N T A S S E M B L Y N O M E N C L A T U R E	E S S E N T I A L I T Y	M A I N T E N A N C E O P E R A T I O N S A N D L E V E L S										N O T E R E F			
			A	B	C	D	E	F	G	H	I	J	K	L		
			S E R V I C E	A D J U S T	A L I N E	C A L I B R A T E	I N S P E C T	T E S T	R E P L A C E	R E P A I R	O V E R H A U L	R E B U I L D	T & T E R Q M T	R E M A R K S		
47	GAGES															
4702	Gages, Mounting, lines and fittings															
	Gages															
55	PUMPS															
5500	Pump Assembly															
	Pump, primer															
	Pump, fire															
5501	Impellers; Rotors															
	Rotor, primer pump															
	Impeller, fire pump															
6506	Suction and/or Discharge Systems															
	Manifolds; valves															
	Head, suction															
	Valve, solenoid; fittings															
	Tubing															
6507	Pump Drives															
	Gears; shafts; seals; bearings															
	Tubing															
	Universal joint															
	Controls, clutch															
	Fittings															
5513	Fluid Lines															
	Fittings; lines; valves; controls															
76	FIRE FIGHTING EQUIPMENT COMPONENTS															
7601	Foam Making Units															
	Tank, storage															
	Valves															
	Rods, valve operating															
	Pipes; fittings; baffles															
7603	Fire Extinguishers															
	Extinguishers, fire															

By Order of the Secretary of the Army:

HAROLD K. JOHNSON,
*General, United State Army,
Chief of Staff.*

Official:

KENNETH G. WICKHAM,
*Major General, United States Army,
The Adjutant General.*

Distribution:

Active Army:

USASA (2)	USIA (2)
ACSI (1)	GENDEP (10)
DCSLOG (1)	Engr Dep (10)
CNGB (1)	Army Dep (2) except
TSG (1)	TOAD (8)
CofEngrs (3)	USA Tml Comd (2)
(1) Army Tml (1)	
CofSptS (1)	Div Engr (2)
USAMB (1)	USAERDL (8)
USAARTYBD (2)	USAMEC (46)
USAARMBD (2)	Engr Cen (5)
USAIB (2)	USAREUR Engr Proc Can (S)
USAADB (2)	USAREUR Engr Sup Con Agei (10)
USAAESWB (2)	Engr Fld Maint Shops (2)
USAAVNBD (2)	Fort Knox Fld Maint (10)
USCONARC (3)	Fld Comd, DASA (8)
OS Maj Comd (6) except	AMS (8)
USASETAF (2)	USAREURCOMZ (2)
USARJ (1)	USA Corps (1)
USAMOCOM (2)	MAAG (1)
MDW (1)	JBUSMC (1)
Armies (2)	Units org under fol TOE:
Corps (2)	5-48 (2)
Div (2)	5-287 (5)
Engr Bde (1)	5-262 (6)
Svc Colleges (2)	5-267 (1)
Br Svc Sch (2) except	5-278 (5)
USACDEC-AG-A (10)	5-279 (2)

NG: State AG (3).

USAR: Same active Army except allowance is one (1) copy for each unit.

For explanation of abbreviations used, see AR 8320-50.

ORGANIZATIONAL MAINTENANCE MANUAL

**TRUCK, FIRE FIGHTING: POWERED PUMPER: FOAM AND WATER,
500 G.P.M. CAP; CENTRIFUGAL PUMP, POWER TAKE OFF DRIVEN;
400 GAL. WATER TANK, 40 GAL. FOAM CHEMICAL TANK (WARD
LAFRANCE MODEL M44A1WLF) FSN 4210-225-9127**

	Paragraph	Page
CHAPTER 1. INTRODUCTION.....		
Section I. General	1,2	2
Section II. Description and data.....	3-5	2
CHAPTER 2. INSTALLATION AND OPERATING INSTRUCTIONS		
Section I. Service upon receipt of equipment	6-10	6
Section II. Movement to a new worksite	11,12	9
Section III. Controls and instruments	13,14	9
Section IV. Operation of equipment	15--27	13
Section V. Operation of auxiliary material used in conjunction with the fire truck	28,29	29
CHAPTER 3. OPERATOR AND ORGANIZATIONAL, MAINTENANCE INSTRUCTIONS		
Section I. Operator and organizational maintenance tools and equipment	30,31	31
Section II. Lubrication.....	32,33	31
Section III. Preventive maintenance services	34-36	35
Section IV. Troubleshooting	37-47	41
Section V. Field expedient repairs	48-50	42
Section VI. Radio interference suppression	51-54	42
Section VII. Retainers, steps, tool box door, guards, hose bed assemblies, and ladder support assemblies	55-67	44
Section VIII. Compartment accessory doors, battery box, and oil pan heater adapter	68-74	50
Section IX. Fuel system	75,76	57
Section X. Air system	77,78	58
Section XI. Electrical system	79-111	59
Section XII. Controls, instruments, and panels	112-120	77
Section XIII. Pumping system	121-133	83
Section XIV. Lubrication system	134,135	96
CHAPTER 4. DEMOLITION OF FIRE TRUCK TO PREVENT ENEMY USE	136-140	97
CHAPTER 5. SHIPMENT AND LIMITED STORAGE		
Section I. Shipment within zone of interior	141,142	99
Section II. Limited storage.....	143, 144	100
APPENDIX I. REFERENCES.....		101
APPENDIX II. MAINTENANCE ALLOCATION		103
APPENDIX III. BASIC ISSUE ITEMS LIST AND MAINTENANCE AND OPERATING SUPPLIES		107
INDEX		116

CHAPTER 1 INTRODUCTION

Section I. GENERAL

1. Scope

a. These instructions are published for the use of the personnel to whom the Ward LaFrance Model M44A1WLF Fire Truck is issued. They provide information on organizational maintenance of the equipment, its accessories, and auxiliaries. This manual also includes instructions for shipment and limited storage.

b. Appendix I contains a list of publications applicable to this manual. Appendix II contains the maintenance allocation chart. Appendix III contains a list of basic issue items authorized the operator of this equipment. The organizational repair parts and special tool list will be listed in TM 5-4210-205-20P, when published.

c. Numbers in parentheses on illustrations indicate quantity. Numbers preceding nomenclature callouts on illustrations indicate the preferred maintenance sequence.

d. The direct reporting, by the individual user, of errors, omissions and recommendations for improving this manual is authorized and encouraged.

DA Form 2028 (Recommended Changes to DA Publications) will be used for reporting these improvements. This form will be completed in triplicate using pencil, pen, or typewriter. The original and one copy will be forwarded direct to the Commanding Officer, 1.U. S. Army Mobility Equipment Center, ATTN: SMOME-MM, P. O. Drawer 58, St. Louis, Mo. 63166. One information copy will be provided to the individual's immediate supervisor (e.g., officer, noncommissioned officer, supervisor, etc.).

e. Report all equipment improvement recommendations as prescribed by TM 38750.

2. Record and Report Forms

DA Form 2258, (Depreservation Guide of Engineer Equipment). For any other record and report forms applicable to the operator and organizational maintenance, refer to TM 38-750.

Note. Applicable forms, excluding standard Form 46 which is carried by the operator. will be kept in a canvas bag mounted on the equipment.

Section II. DESCRIPTION AND DATA

3. Description

The War(LaFrance Model M44A1WLF Fire Truck has the following major components of fire-fighting equipment mounted on the chassis. A foam concentrate tank is mounted in the fire pump compartment immediately behind the personnel cab, while two pioneered hose reel assemblies, one on each side of the truck, are installed in the hose reel and pump compartments (figs. 1 and 2). A 500 gallon water tank with a water tank fill provides a means filling the tank without engaging the fire pump. The support assembly is locate above the water tank and provides a means of securing

and transporting the ladders. Two spotlights one on each side of the personnel cab windshield cab windshield posts, and two floodlights are mounted on the rear of the truck to provide a means of lighting during night operation. The battery charger receptacles are located on the rear of the truck for connection to an external battery charging source. The fire extinguisher brackets are on the rear stanchion of the truck. A combination siren and siren light, located on top of the left front fender provides means o warning in an emergency operation. All fire fighting equipment enclosed in an insulated body.

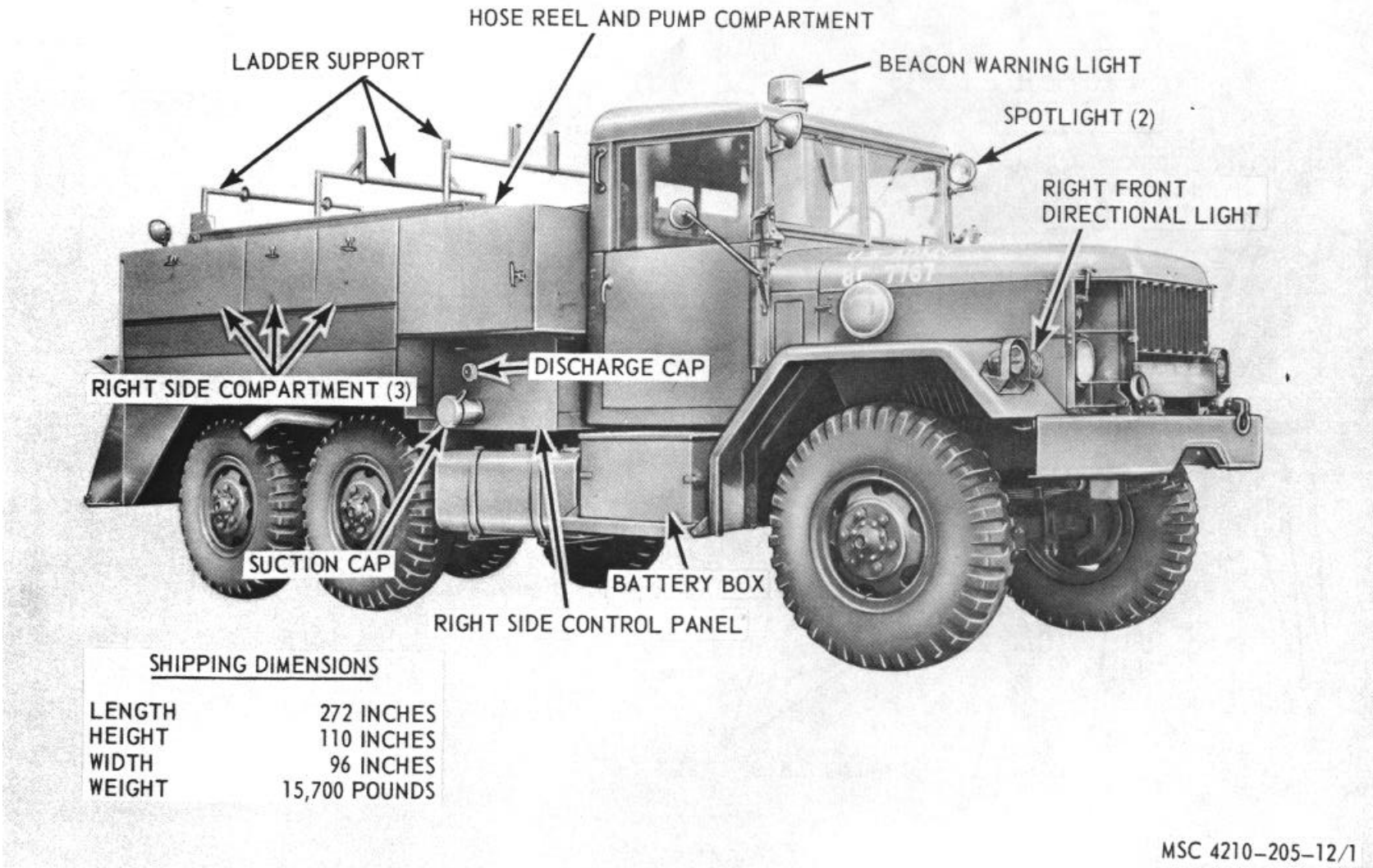

Figure 1. Fire truck, right front, three-quarter view and shipping dimensions.

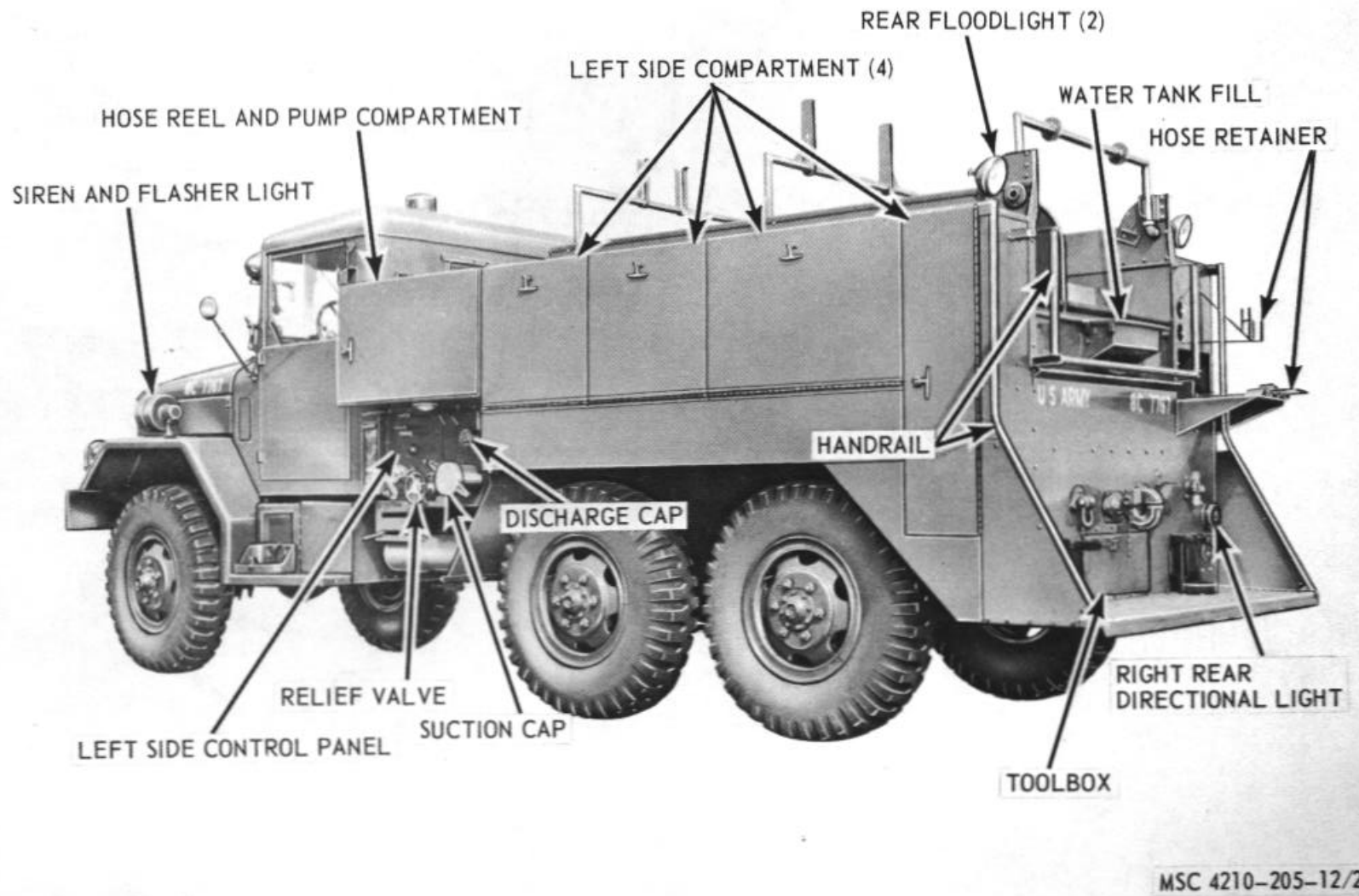

Figure -2. Fire truck, left rear, three-quarter view.

4. Identification and Tabulated Data

a. *Identification.* The fire truck has three identification plates. Refer to TM 9-2320-235-10 for chassis and engine data plates.

- (1) *Corps of Engineers plate.* Provides a short nomenclature, Federal stock number, manufacturer's name, equipment model, and serial numbers. It is mounted in the cab on the cab front panel.
- (2) *Operating instruction plate.* Provides instructions for pumper operation. It is mounted on the left side of the unit body near the pump station.
- (3) *Pumper capacity plate.* Provides the engine revolution per minute, pressure and gallons per minute for pump, operation. It is mounted on the left side of the unit body near the pumper station.

b. Tabulated Data.

(1) *Water pump.*

Manufacturer Hale Fire Pump Company
Type Centrifugal
Serial number 24192
Capacity 500 gpm (gallons per minute)
Type drive Power takeoff shaft from truck transfer ease
Water pressure control Throttle and relief valve control

Performance data:

GPM	Pressure	Engine Rpm
500	120	1550
250	200	1775
167	250	1980
80%, Engine peak	2080 rpm (revolutions per minute)	
90% Engine peak	2340 rpm	

(2) *Primer pump.*

Manufacturer Hale Fire Pump Company
Type Microswitch actuator, rotary vacuum pump

(3) *Water tank.*

Manufacturer Ward LaFrance Co.
Capacity 400 gal (gallons)

(4) *Foam tank.*

Manufacturer Ward LaFrance Co.
Capacity 40 gal

(5) *Hose reels assemblies.*

Type Electric Rewind Mechanical
..... or manual
Pressure 3000 psi (pounds per square inch)

(6) *Heat exchanger.*

Manufacturer Sekdure Co.
Model 1113-1

(7) *Foam metering valve.*

Manufacturer Rockwood Sprinkler Co.
Solution Foam Liquid and Water
Water supply Water tank, hydrant or suction lift
Type Adjustable

(8) *Hose reel motor.*

Manufacturer The Leland Ohio Electric Co.
Horsepower 1/4
Volts 24
Amperes 20
Time Rating 5 minutes
Revolutions per minute 500
Serial number 19110 63K CCW

(9) *Siren.*

Manufacturer Sireno Signal Mfg. Corp.
Model number VAL,
Serial number 1791
Federal stock number .. 6350577-3417
Volts 24 dc (direct current)

(10) *Beacon warning light.*

Manufacturer Sireno Signal Mfg. Corp.
Serial number 192
Volts 24

(11) *Dimensions and weight.*

Overall length 272 inches
Overall height 110 inches
Overall width 96 inches
Shipping weight 15,700 pounds

(12) *Wiring diagram.*

Figure Y. Wiring diagram.

(Located in back of manual)

5. Difference in Models

This manual covers only the Ward LaFrance Model M44A1WLF Fire Truck. No known differences exist for the model covered by this manual.

CHAPTER 2

INSTALLATION AND OPERATING INSTRUCTIONS

Section I. SERVICE UPON RECEIPT OF EQUIPMENT

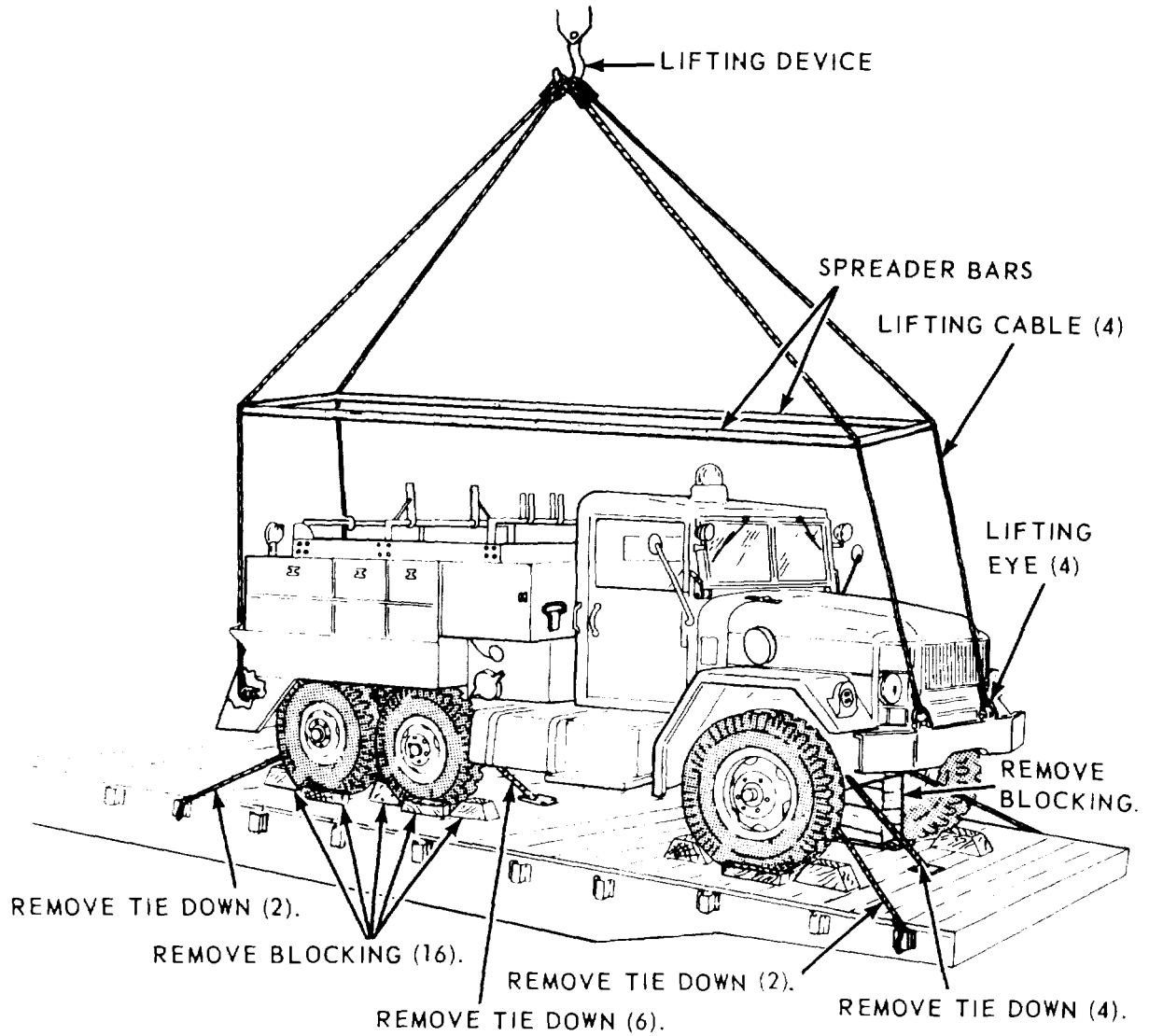

MSC 4210-205-12/4

Figure 4. Blocking and tiedown removal and lifting with as crane.

6. Unloading the Equipment

a. Preparation for Unloading. Refer to figure 4, and remove blocking and tiedown from wheels and axles.

Note. The fire truck will have to be jacked up slightly to remove blocking from axles.

b. Unloading.

(1) Unloading by driving or towing.

(a) Drive the fire truck off the carrier using a suitable ramp. Refer to TM 9-232023,5-10 for the fire(truck operating details.

(b) In the event no is available to drive the truck off the carrier, construct a ramp following construction details and specifications contained in figure 5.

(2) Lifting. Attach four slings of equal length to the four lifting rings as illustrated on figure 4 with a hoist of sufficient capacity lift the fire truck off and away from carrier.

Caution: Be sure the fire truck has sufficient clearance before unloading.

7. Unpacking the Equipment

a. *Unpacking.*

(1) Open the electrolyte boxes and remove the bottles of electrolyte.

(2) Open packing boxes and place tools in tool box.

(3) Place fire extinguisher in compartment.

b. *Depreservation.* Prepare the fire truck for inspection and operational as outlined on DA Form 2258 (Depreservation Guide) that is attached on or near the operator's controls.

8. Inspecting and Servicing Equipment

Note. Make sure equipment is completely deprocessed before servicing. Make sure preservatives have been remove from such items as crankcase, fuel tank, gearboxes, and the like.

a. *Inspection.*

(1) Make a thorough visual inspection of the fire truck for damage that may have occurred during shipment. Inspect components for loose mounting and missing mounting hardware.

(2) Inspect the packing list and make sure that all equipment listed has been received.

(3) Inspect the truck chassis TM 9-2320-23510.

b. *Servicing.*

(1) Perform the daily and (quarterly maintenance services paras. 35 and 36).

(2) Lubricate the truck chassis TM 9-2320-235-10).

(3) Fill the truck cooling system (TM-923-235-10).

c. *Emergency Duty.* If tile fire truck is to be placed on emergency standby duty, close water and foam concentrate drain valves and fill each tank. Both tanks may be filled with water or the 400-gallon tank with water and the 40-gallon tank with foam concentrate, depending upon the individual requirements.

d. *Initial Test.*

(1) Unload fire truck (para. 6)

(2) Start the engine (TM 9-2320-235-10), operate at low speed for 5 to 10 minutes , and make sure the engine is operating properly.

(3) Do not operate the truck at speeds in excess of 25 miles per hour (mph) during break-in-period.

(4) Fill the 400-gallon water tank and the 40-gallon foam tank (para. 18).

(5) Check performance of fire truck pump controls, instruments, and gages.

9. Installation of Separately Packed Components

a. Batteries are shipped adding electrolyte.

b. For battery servicing and installation, refer to TM 9-2320-235-10.

Warning: Do not smoke or use an open flame in the vicinity when servicing the batteries. Batteries generate hydrogen, a highly explosive gas.

10. Installation or Setting Up Instructions

a. *General.* The fire truck will be received completely assembled and ready for use, except for servicing the batteries.

b. *Batteries.* Refer to TM 9-2320-235-10 for battery service.

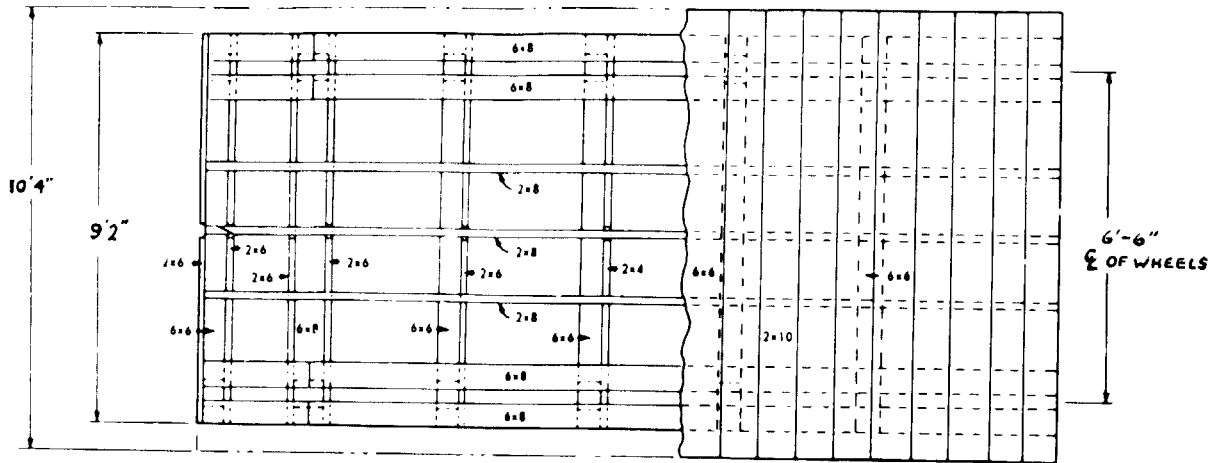

- NOTES:
 (UNLESS OTHERWISE NOTED)
 1. SCALE - 1/2 IN. = 1 FT.
 2. MATERIAL - 6x8, 6x6, 2x6 (OAK
 TIMBER, COMMON)
 2x10 AND 2x4
 (TIMBER OPTIONAL)

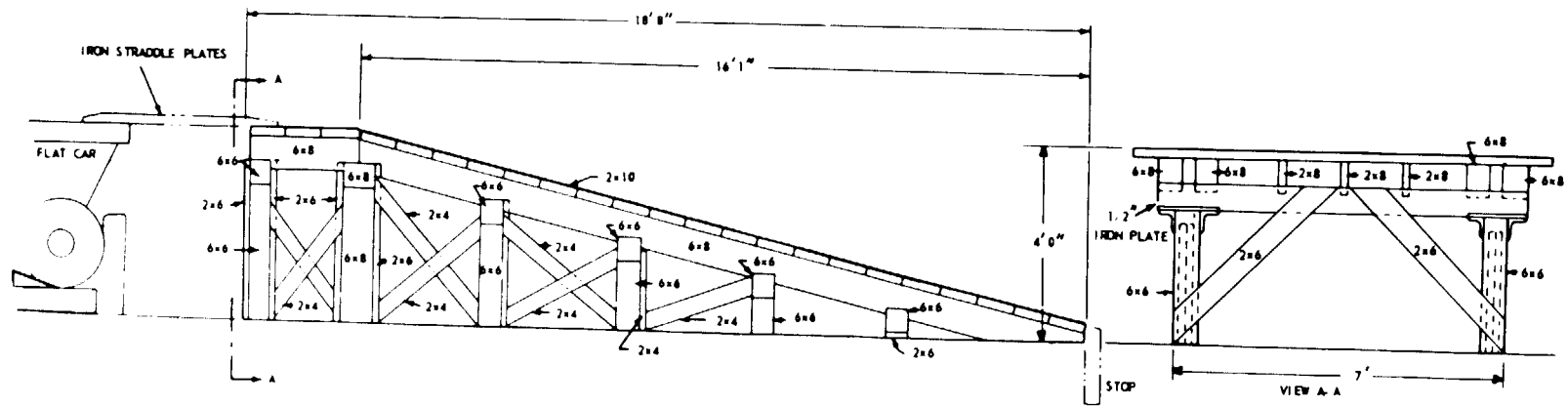

MSC 4210-205-12/5

Figure 5. Ramp construction details.

Section II. MOVEMENT TO A NEW WORKSITE

11. Dismantling for Movement

a. The fire truck requires no (disassembly other than the safe and -proper storage of hoses, ladders, hose connections, adapters, and accessories for movement to a new worksite.

b. Disconnect the battery cables and drain the fuel (TI 9-2320-235-10) in the event the fire truck is moved by some means other than its own power.

Caution: Do not exceed 20 mph on good hard surface road or 10 mph on secondary roads or across country when towing the fire truck.

c. Drain the water tank and foam tank. (para 20).

d. Lock the hose reel assemblies (para. 19).

12. Reinstallation After Movement

a. Fill the water tank and foam tank (para. 18).

b. Service the carriers' fuel system (TM 9-2320-235-10).

c. Connect the battery cables to the batteries (TM 9-2320-235-10).

Section III. CONTROLS AND INSTRUMENTS

13. General

This section describes, locates, illustrates, and furnishes the operator, crew, or driver sufficient information about the various (controls and instruments for proper operation of the fire truck.

14. Controls and Instruments

The purpose, location, and use of the controls and normal readings of the instruments and gages are illustrated on figure 6. Refer to TM 9-2320-235-10 for chassis and engine controls and instruments.

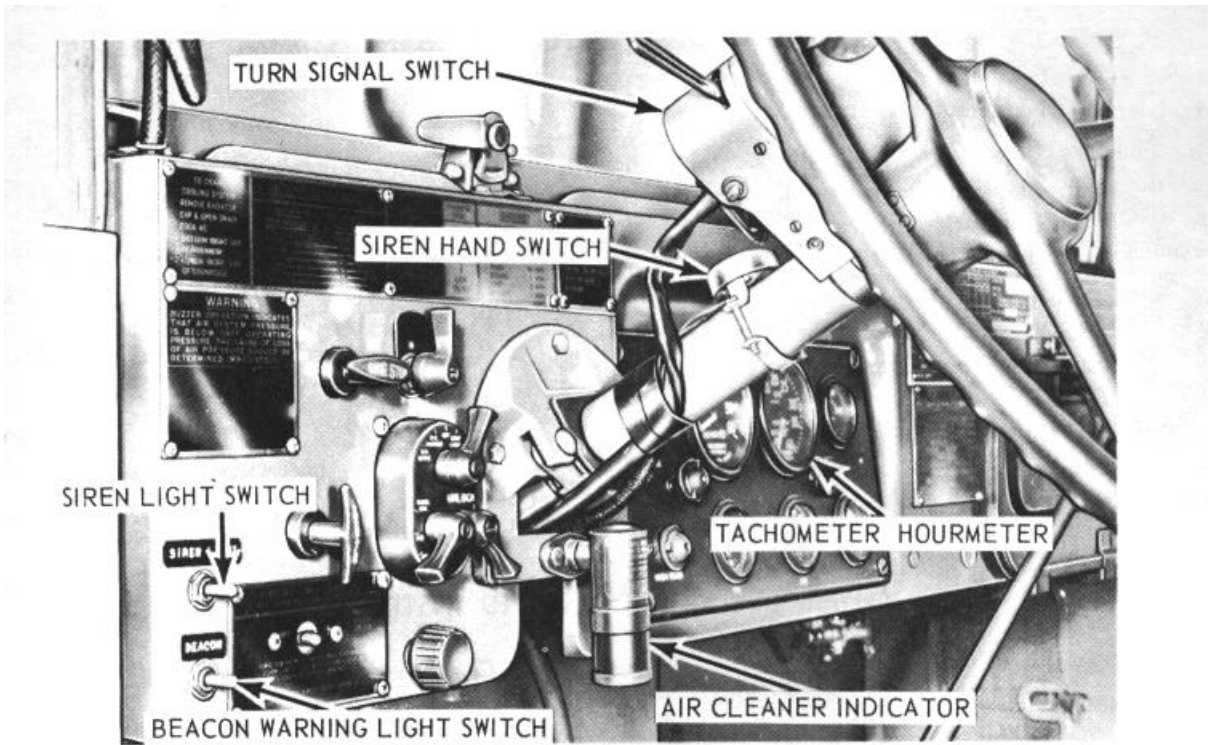

A

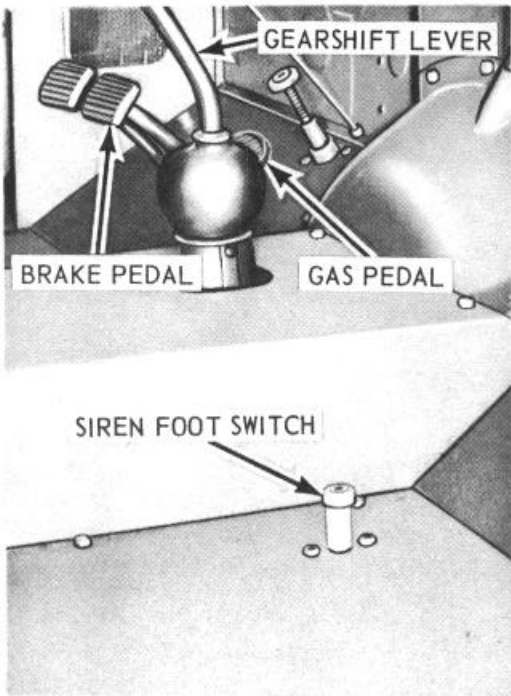

B

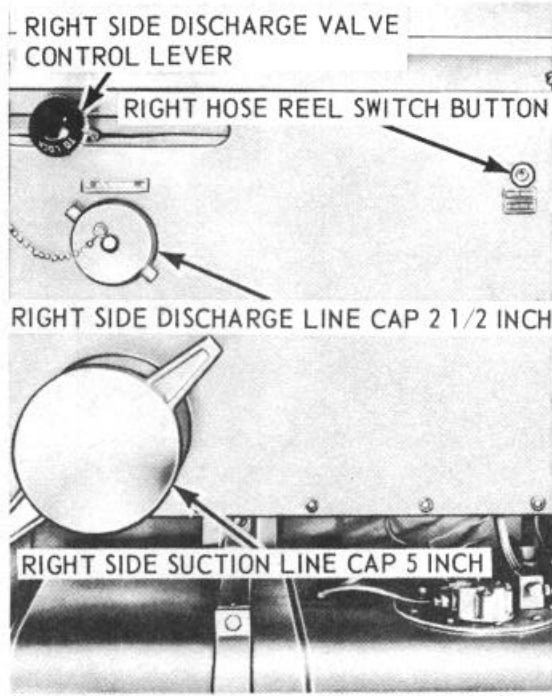

C

MSC 4210-205-12/6 (1)

A—Cab controls and instruments

B—Siren foot switch

C—Right side control panel

Figure 6. Controls and instruments.

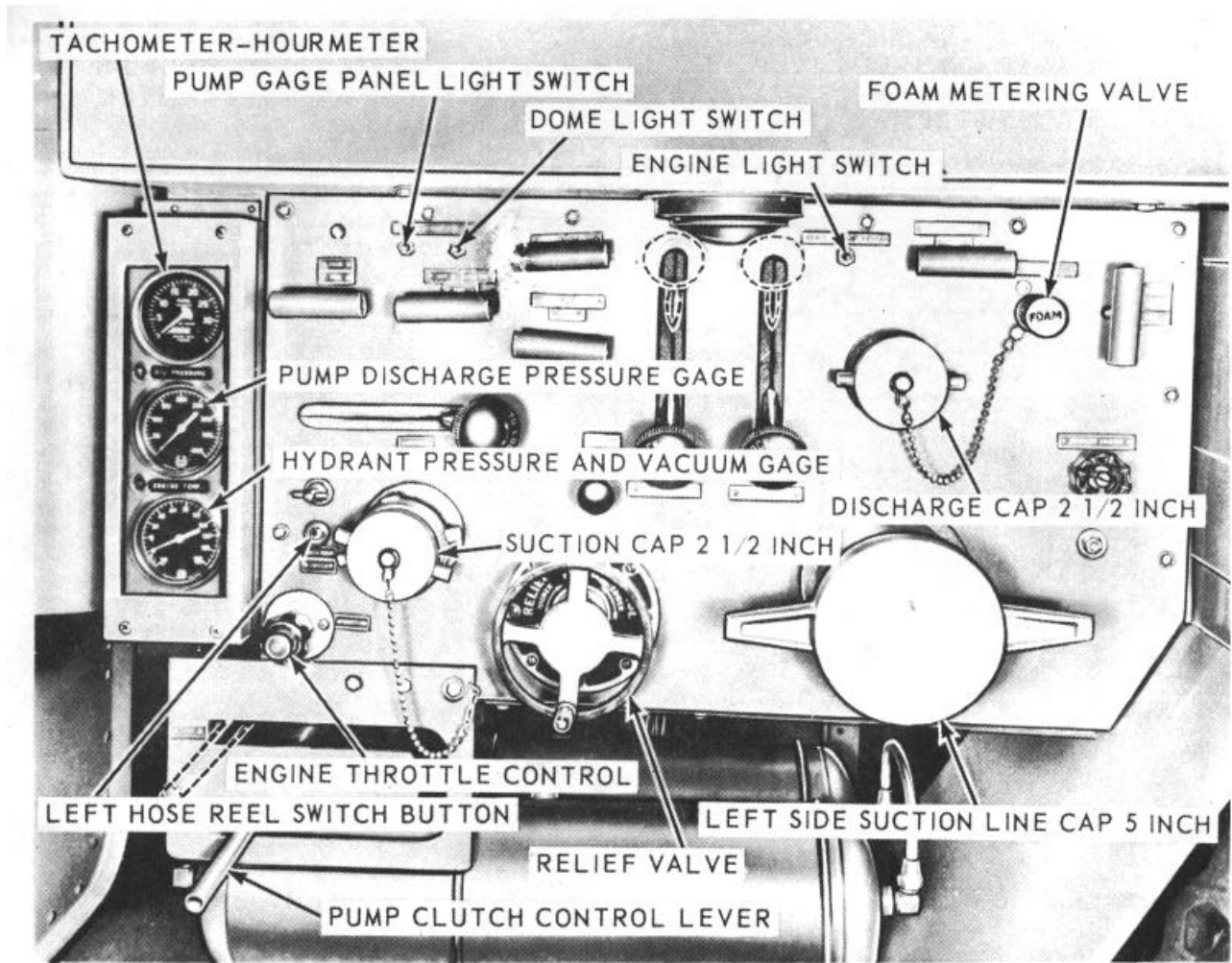

D

MSC 4210-205-12/6 (2)

D-Left side controls and instruments

Figure 6-Continued.

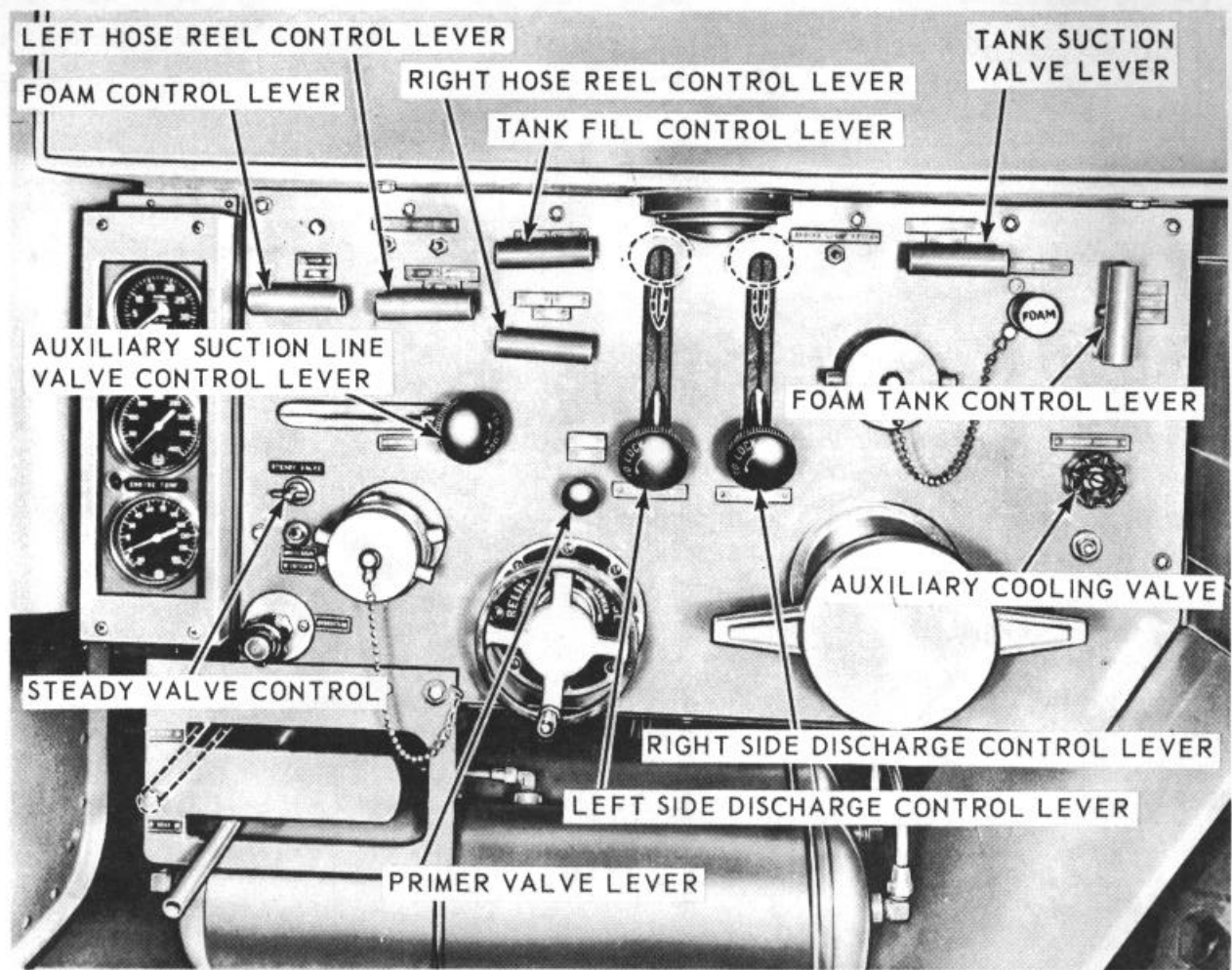

E

MSC 4210-205-12/6 ③

Figure 6-Continued.

E-Left side controls and instruments-Continued

Section IV. OPERATION OF EQUIPMENT

15. General

a. The instructions in this section are published for the information and guidance of the personnel responsible for operation of the fire truck.

b. The operator must know how to perform every operation of which the fire truck is capable. This

section gives instructions on starting and stopping the fire truck, on the basic motions to perform the specific tasks for which the equipment is designed. Since nearly every job presents a different problem, the operator or crew may have to vary the given procedure to fit the individual job.

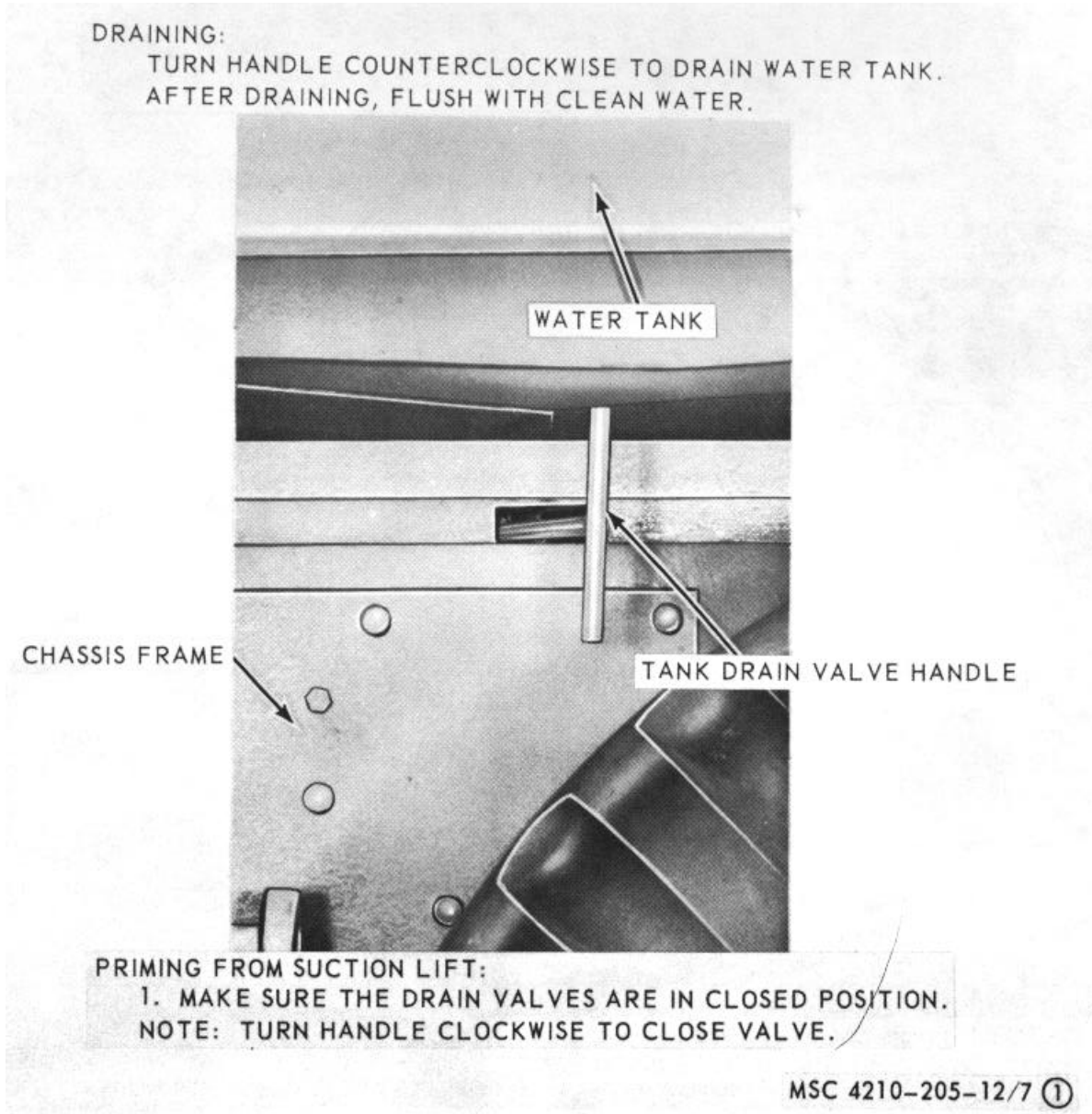

Figure 7. Priming pump details.

16. Starting the Engine

- a. Perform the daily preventive maintenance (para. 35).
- b. Start the engine (TM 9-2320-235-10).

17. Stopping the Engine

Stop the engine (TM 9-2320-235-10).

18. Priming Water Pump and Filling Tanks

- a. *Priming Water Pump.* Refer to figure 7, and prime the water pump by one of the three methods.
- b. *Filling the 400-Gallon Water Tank From Suction Lift.* Refer to figure 8, and fill the 400-gallon water tank.

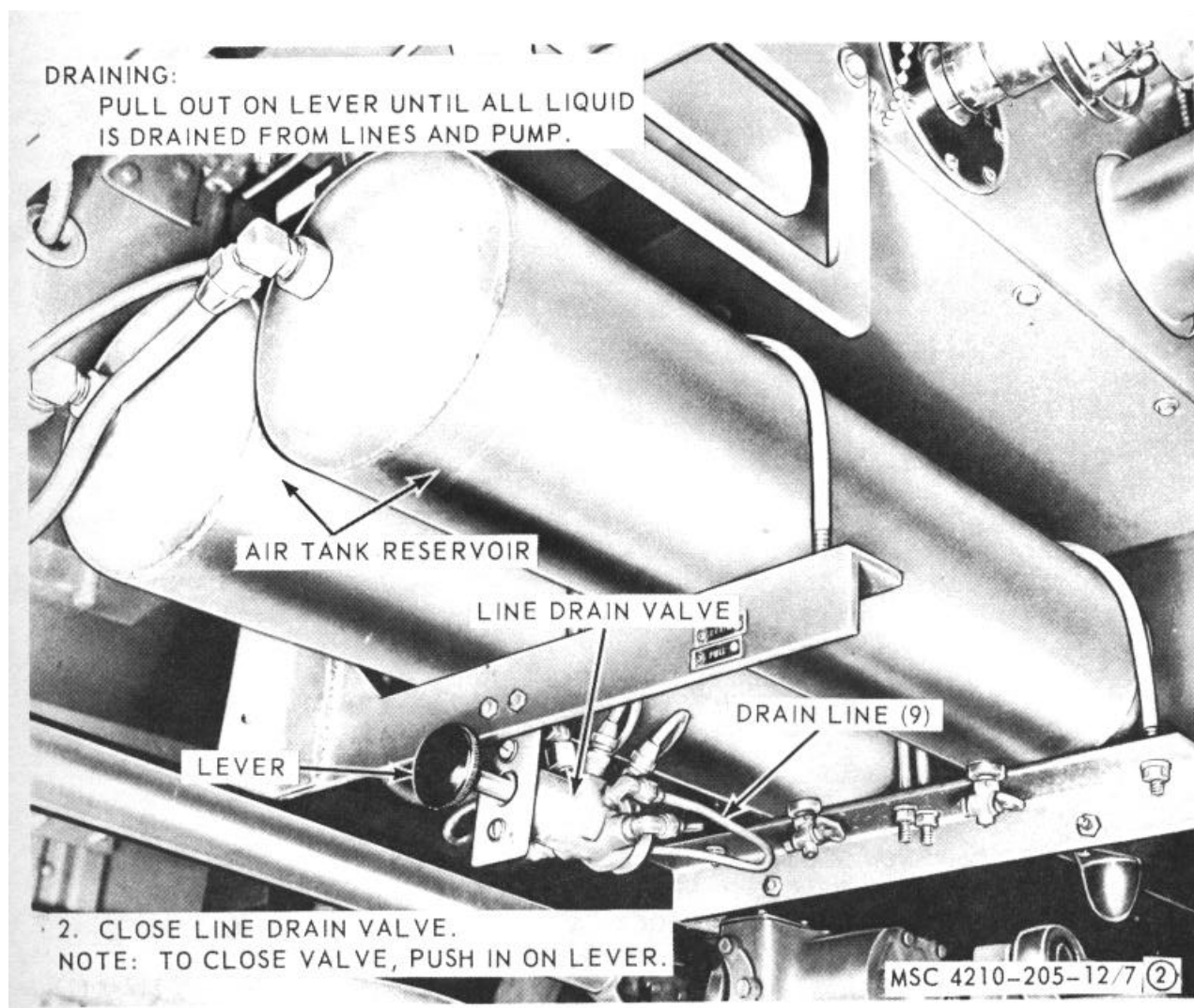

Figure 7-Continued.

3. START THE ENGINE (PAR. 16).
4. DEPRESS CLUTCH PEDAL AND PLACE TRANSFER SHIFT LEVER IN NEUTRAL POSITION.
5. MOVE TRANSMISSION GEARSHIFT LEVER INTO 5TH SPEED.
6. RELEASE CLUTCH PEDAL AND ENGAGE HAND BRAKE LEVER.

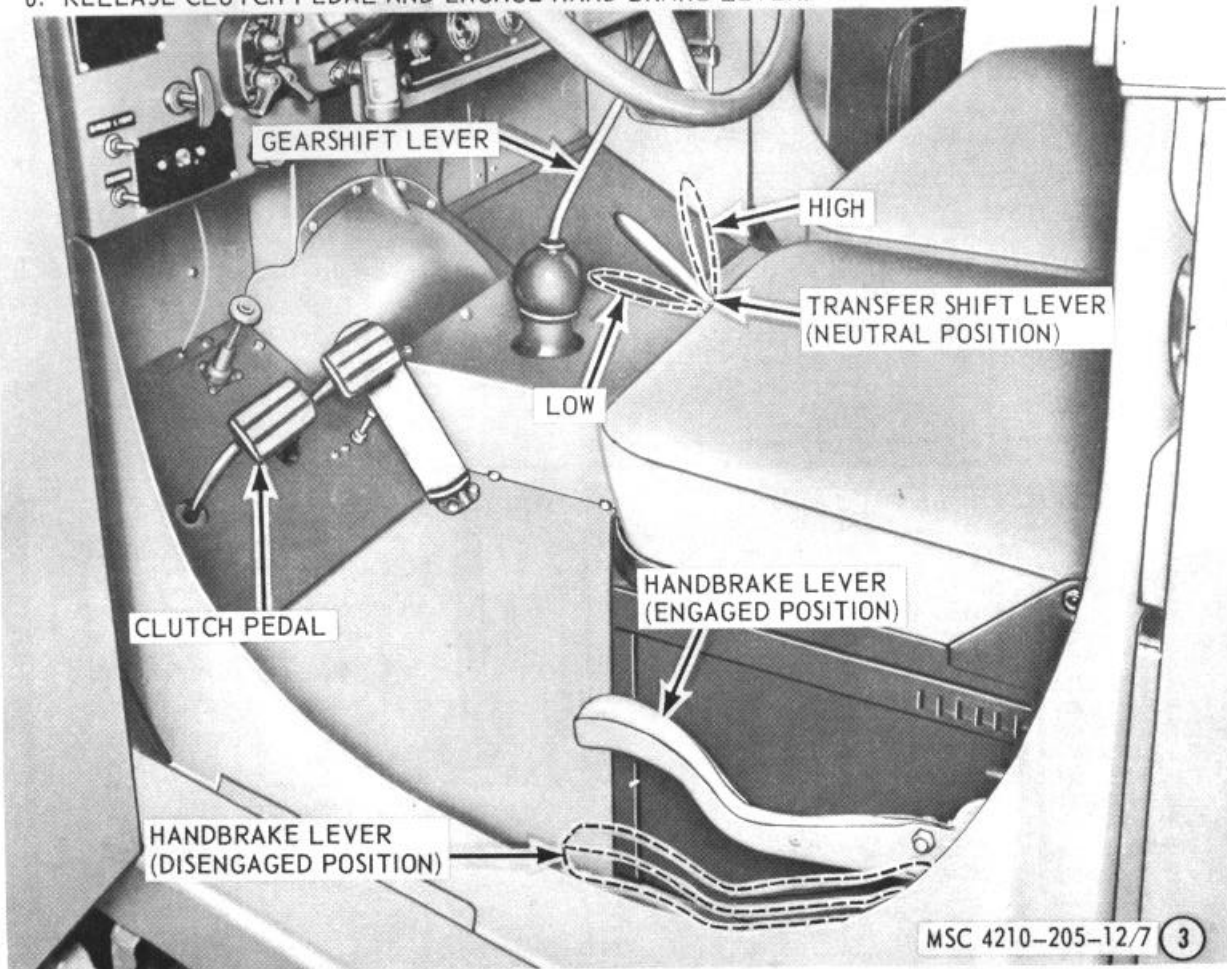
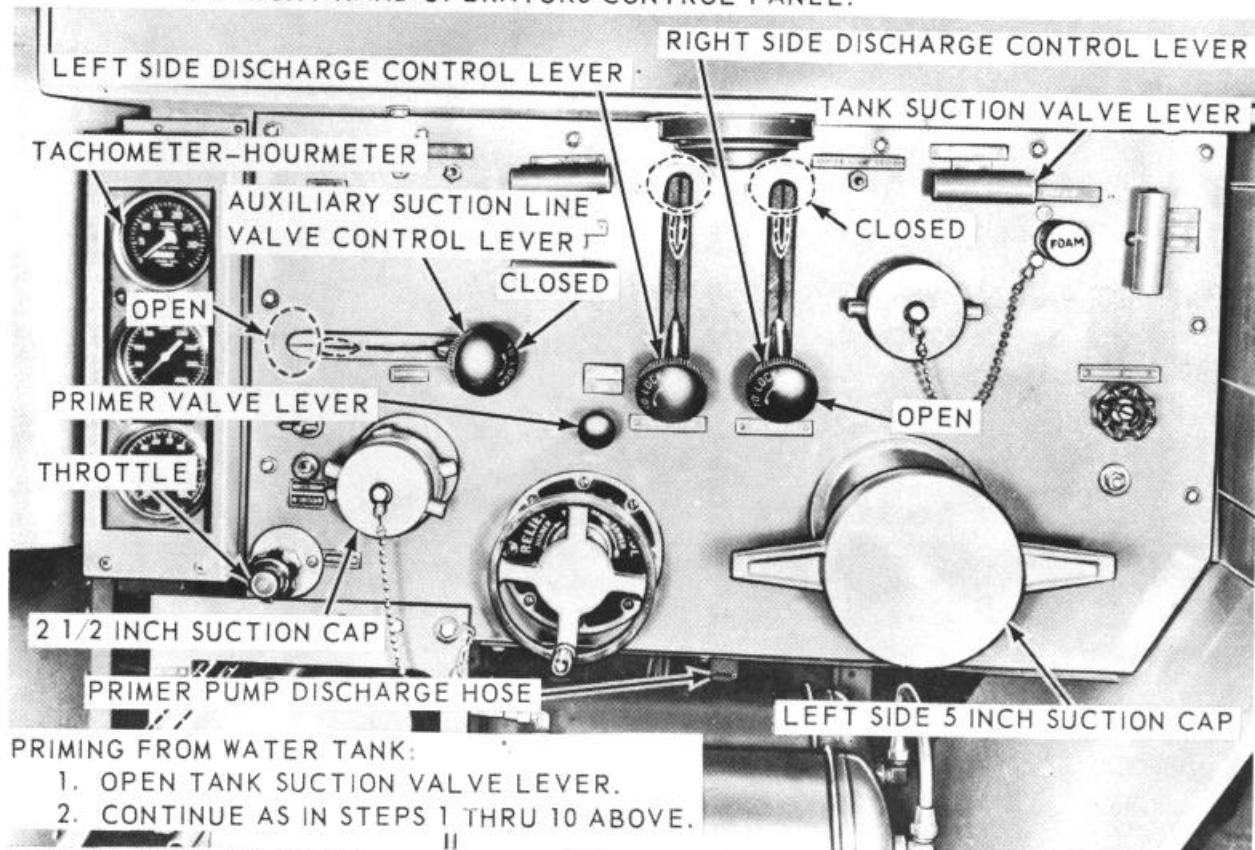

Figure 7-Continued.

7. ALL CONTROLS AND VALVES SHOULD BE IN CLOSED POSITION.
8. REMOVE SUCTION CAPS FROM LEFT OR RIGHT SIDE AS DESIRED AND ATTACH ONE END OF HOSE WITH STRAINER TO SUCTION LINE AND ONE END IN WATER.
NOTE: WHEN USING THE 2 1/2 INCH SUCTION CAP, OPEN THE AUXILIARY SUCTION LINE VALVE LEVER.
CAUTION: SEE THAT STRAINER AT LOWER END OF HOSE IS AT LEAST 2 FEET BELOW WATER SURFACE TO AVOID TAKING AIR BUT FAR ENOUGH FROM BOTTOM TO PREVENT PUMPING SAND AND OTHER FOREIGN MATERIAL.
9. ADJUST THROTTLE TO RUN AT 500-600 RPM.
10. PULL PRIMER PUMP LEVER ALL THE WAY OUT. HOLD IN POSITION UNTIL DISCHARGE HOSE IS FREE OF AIR AND WATER STARTS TO DISCHARGE.
CAUTION: IF PRIMING PUMP DOES NOT DISCHARGE WATER IN 10 TO 30 SECONDS PUSH PRIMER LEVER IN AND LOOK FOR AIR LEAKS.
NOTE: RIGHT HAND DISCHARGE VALVE CAN BE OPERATED FROM EITHER LEFT OR RIGHT HAND OPERATORS CONTROL PANEL.



- PRIMING FROM WATER TANK:
1. OPEN TANK SUCTION VALVE LEVER.
 2. CONTINUE AS IN STEPS 1 THRU 10 ABOVE.

- PRIMING FROM HYDRANT:
1. CONTINUE AS IN STEPS 1 THRU 9 (PRIMING FROM SUCTION LIFT ABOVE).
NOTE: DO NOT PULL PRIMER VALVE LEVER. PRESSURE FROM HYDRANT WILL FORCE WATER INTO PUMP.
 2. REMOVE DESIRED SUCTION CAPS AND CONNECT ONE END OF HOSE WITH STRAINER TO SUCTION LINE AND OTHER END WITH HYDRANT, AND OPEN HYDRANT.

MSC 4210-205-12/7 (4)

TAGO 6839A

Figure 7-Continued.

1. MAKE SURE ALL VALVES AND CONTROLS ARE IN CLOSED POSITION.
2. OPEN THE WATER TANK FILL CONTROL LEVER.
3. PRIME THE WATER PUMP FROM SUCTION LIFT (FIG. 7).
4. MOVE PUMP CLUTCH CONTROL LEVER FROM ROAD TO PUMP POSITION.
5. FILL THE WATER TANK.

NOTE: TANK OVERFLOW IS ON FRONT LEFT CORNER OF TANK WITH DISCHARGE PIPE RUNNING UNDER THE TRUCK.

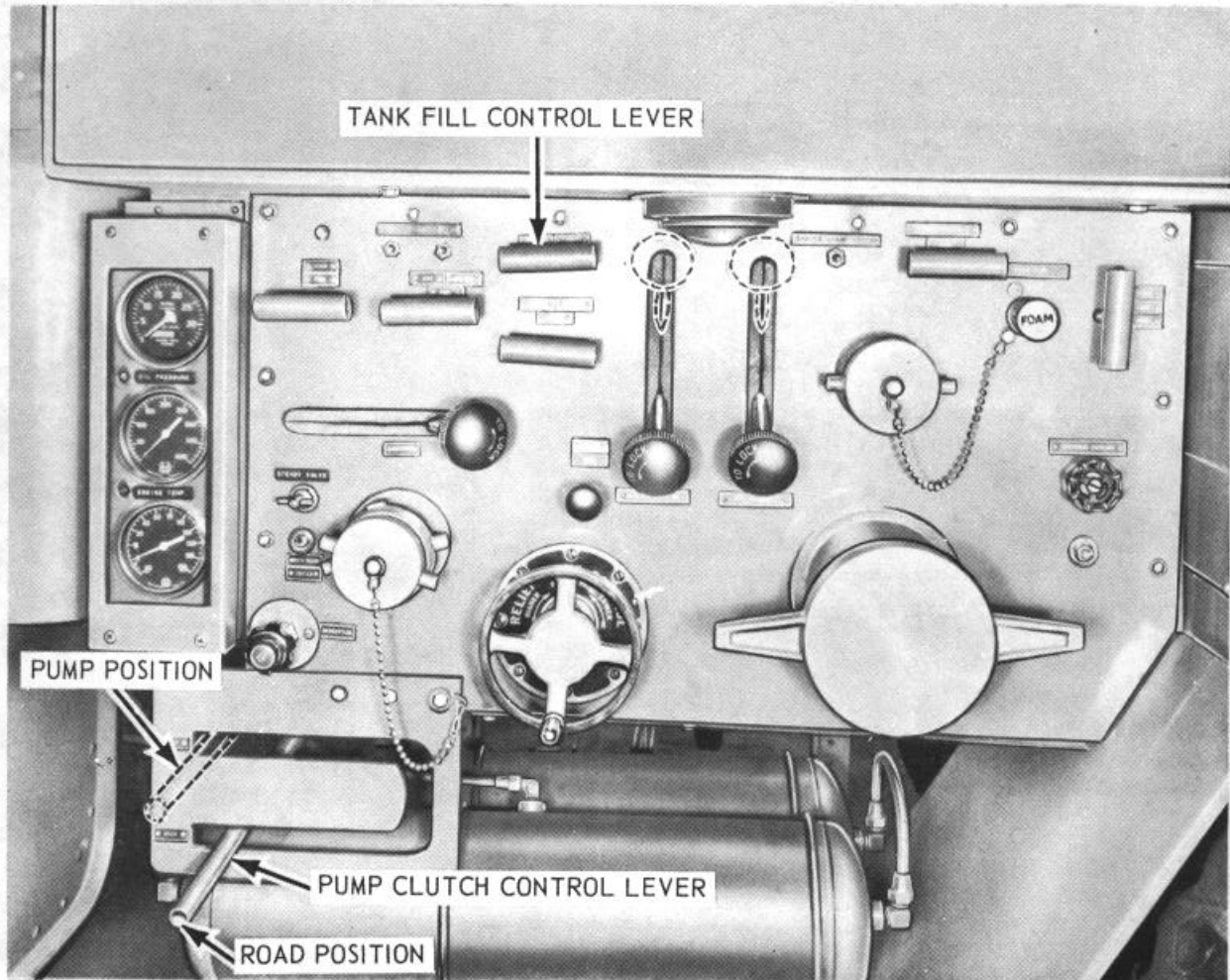

CAUTION: THE PUMP CLUTCH CONTROL LEVER MUST BE IN THE ROAD POSITION WHEN WATER IS NOT BEING CIRCULATED THROUGH THE SYSTEM.

MSC 4210-205-12/8

Figure 8. Filling water tank from suction lift.

c. *Filling the 400-Gallon Water Tank Through the Water Tank Fill.* Refer to figure 9, and fill water tank through water tank fill.

d. *Filling the 400-Gallon Water Tank From a Hydrant.* Refer to figure 10, and fill the 400-gallon water tank from a hydrant.

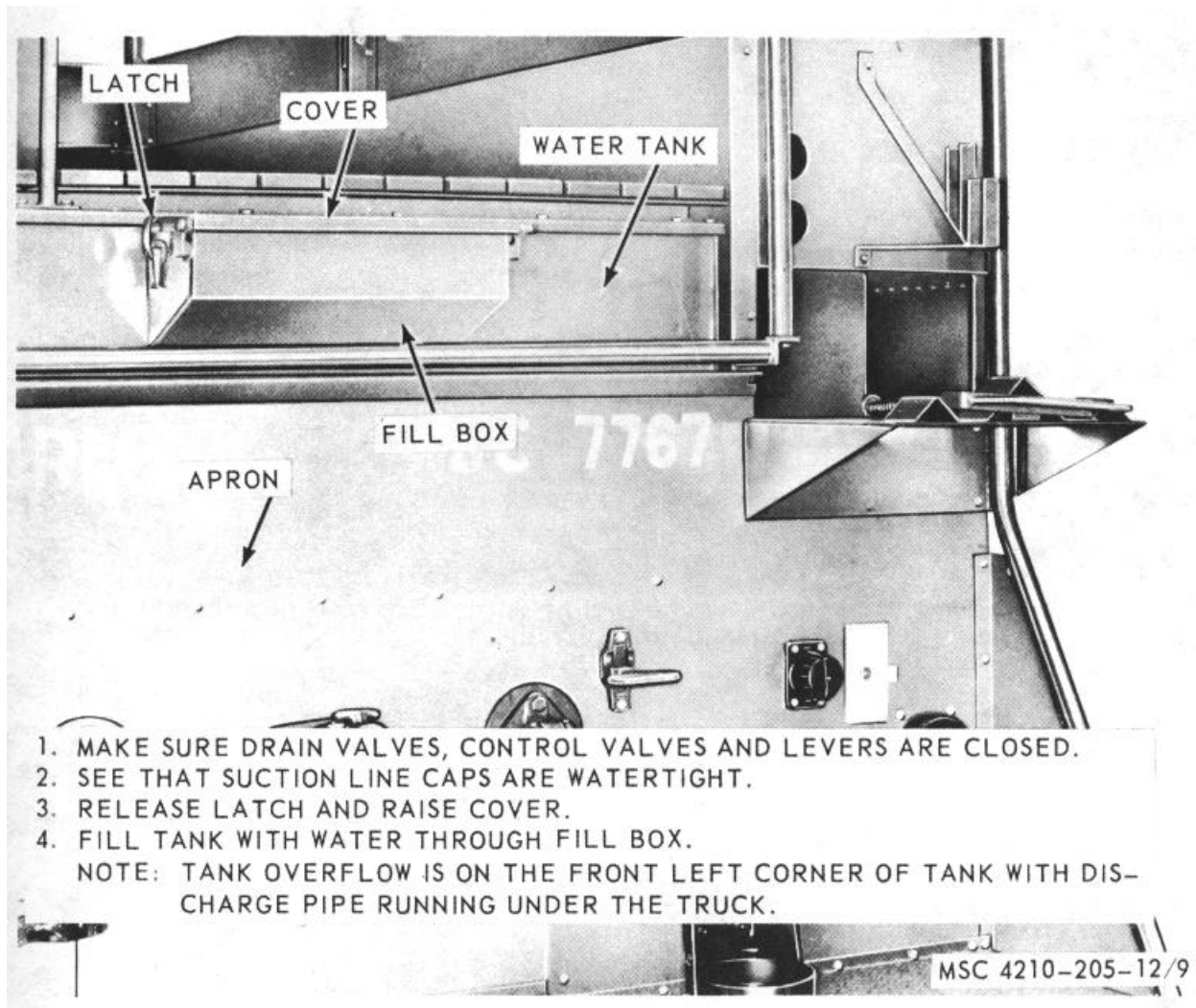
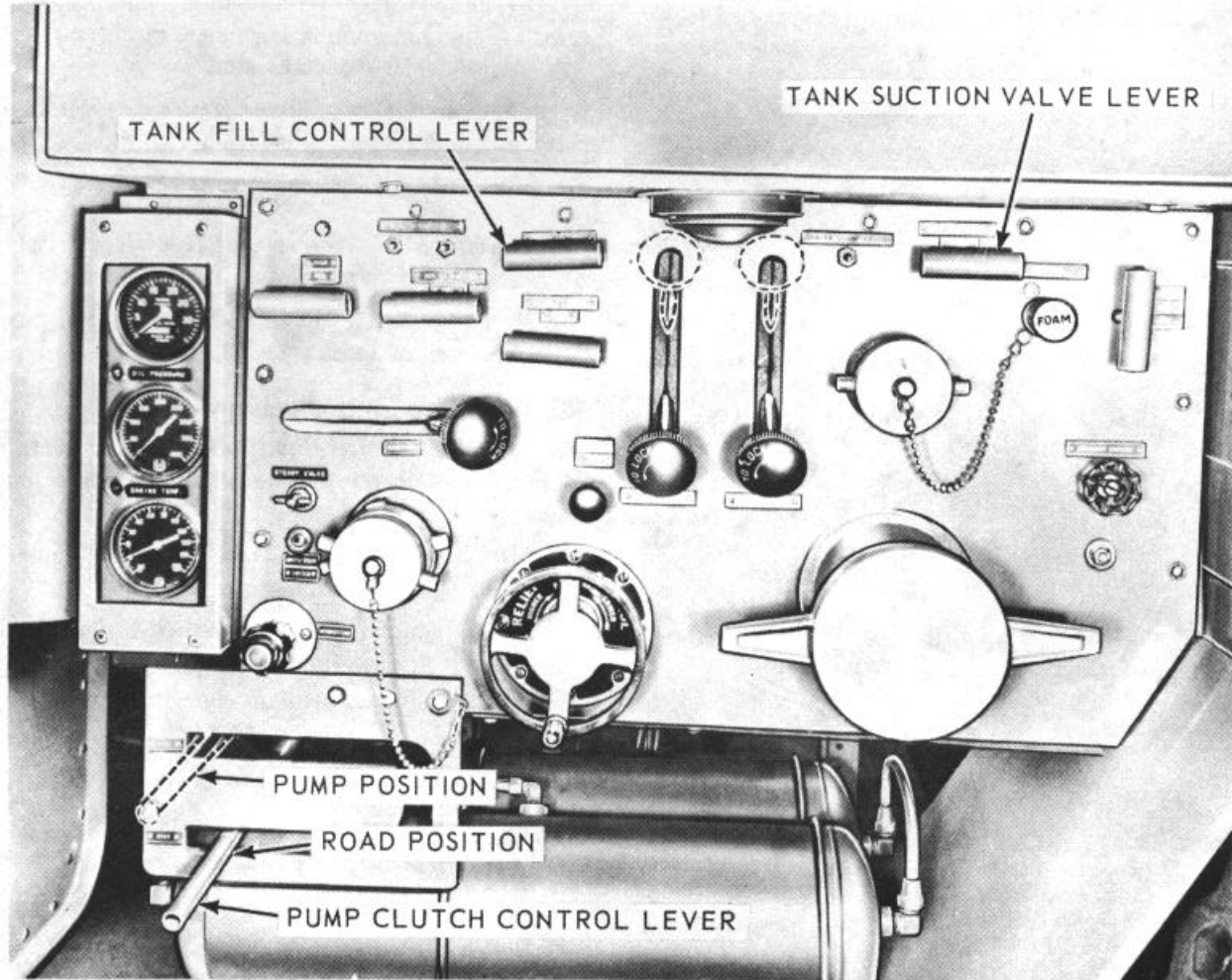

Figure 9. Water tank fill.

1. MAKE SURE ALL VALVES AND CONTROLS ARE IN THE CLOSED POSITION.
2. OPEN WATER TANK FILL CONTROL LEVER.
3. PRIME THE WATER PUMP FROM HYDRANT (FIG. 7).
4. MOVE PUMP CLUTCH CONTROL LEVER FROM ROAD TO PUMP POSITION.
5. FILL THE WATER TANK.

NOTE: TANK OVERFLOW IS ON THE FRONT LEFT CORNER OF TANK WITH DISCHARGE PIPE RUNNING UNDER THE TRUCK.



CAUTION: THE PUMP CLUTCH CONTROL LEVER MUST BE IN THE ROAD POSITION WHEN WATER IS NOT BEING CIRCULATED THROUGH THE SYSTEM.

MSC 4210-205-12/10

Figure 10. Filling water tank from hydrant.

e. *Filling 40-Gallon Foam Tank With Concentrate.* Refer to figure 11, and fill the 40-gallon foam tank with concentrate.

NOTE:

ALWAYS FLUSH THE FOAM SYSTEM AS SOON AS IT IS DRAINED UNLESS IT IS TO BE IMMEDIATELY REFILLED.

DRAINING: PLACE A SUITABLE CONTAINER UNDER FOAM TANK AND OPEN DRAINCOCK.

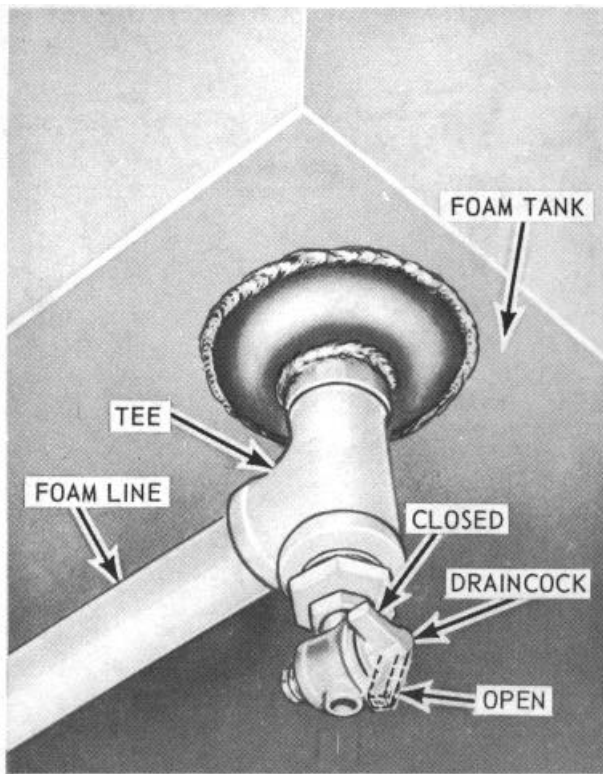

1. MAKE SURE FOAM TANK DRAINCOCK IS IN CLOSED POSITION.
2. MAKE SURE ALL VALVES AND CONTROLS ARE IN CLOSED POSITION.

A

MSC 4210-205-12/11 (1)

Figure 11. Foam tank filling details.

f. *Filling Both Tanks With Foam Concentrate.* Refer to figure 12, and fill both foam and water tanks with concentrate.

19. Pumping Details

a. *Pumping Water From Suction Lift.* Refer to figure 13, and pump water from suction lift.

b. *Pumping Water From the 400-Gallon Tank.*

(1) Water may be pumped either independently to one, or to all of the outlets after removing the discharge caps and connecting hoses.

(2) Prime the water pump from water tank (para. 18).

(3) Follow steps 4 through 7, figure 13, outlined in pumping from suction lift to pump water from water tank.

c. *Pumping Water From Hydrant.* Refer to figure 14, and pump water from hydrant.

Note.

If possible, flush dirt from hydrant before attaching hose.

d. *Pumping Water from the Hose Reels.* Refer to figure 15, and pump water from hose reels.

e. *Pumping Foam.* Refer to figure 16, and pump foam from foam tank.

20. Draining and Flushing Details

a. *Draining Water Pumping and Lines.* Refer to figure 7, and (drain the water pump, valves, and lines.

b. *Draining the Water Tank.* Refer to figure 7, and drain the 400-gallon water tank.

c. *Draining and Flushing the 40-Gallon Foam Concentrate Tank.* Refer to figure 17, and drain and flush the 40-gallon foam concentrate tank.

d. *Flushing Discharge Line System.* Refer to figure 177, and flush the discharge line system.

21. Final Test Before Housing Fire Truck After Returning From Fire

a. Perform daily preventive maintenance services (para. 35).

b. Close all controls and valves and have suction caps tight.

c. Pull primer valve lever and run until combination gage shows about 15 inches of vacuum in 15 seconds.

d. Close primer valve lever and watch gage. If vacuum falls rapidly it indicates air leakage.

e. Test suction hose by attaching suction hose to pump and placing suction tube cap on end of suction hose in place of strainer and test for leaks.

f. Repair or report to direct support maintenance.

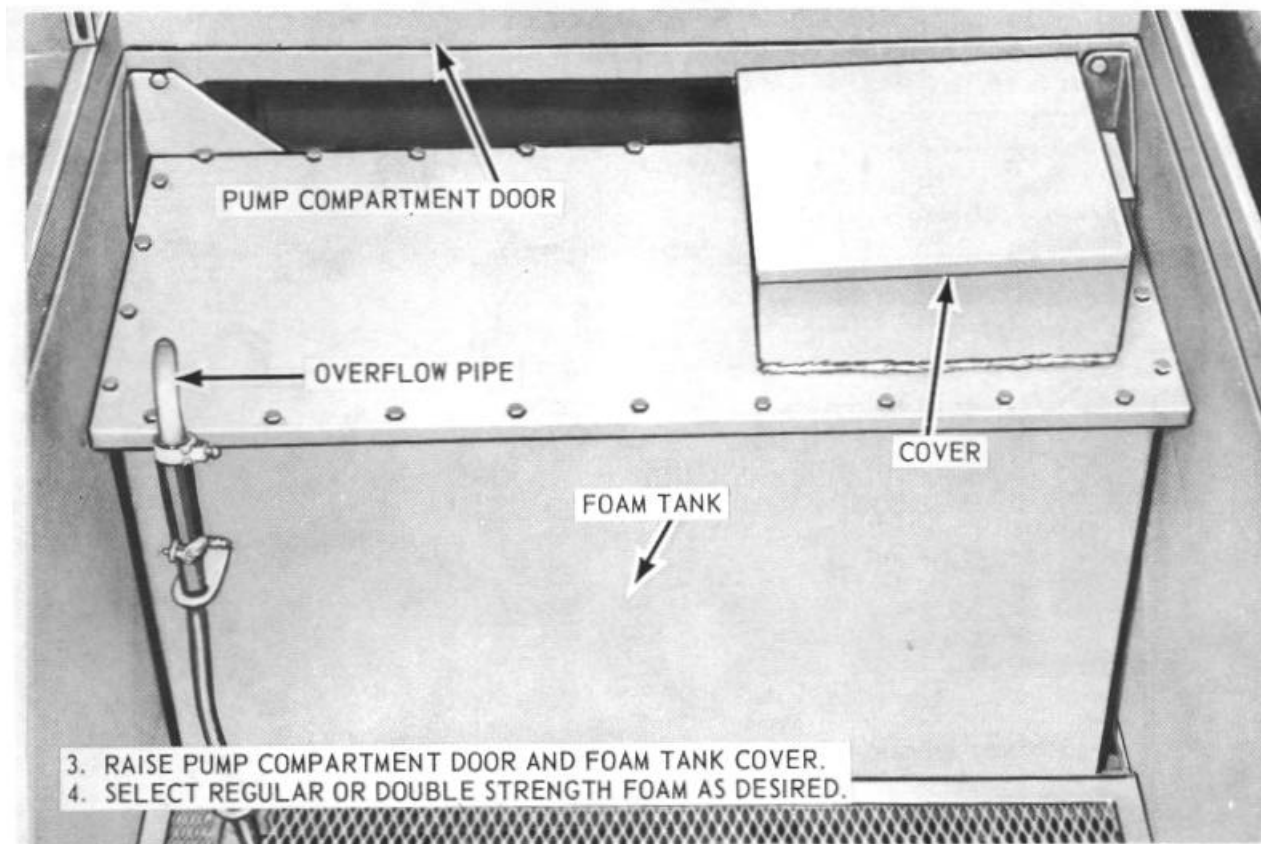

B

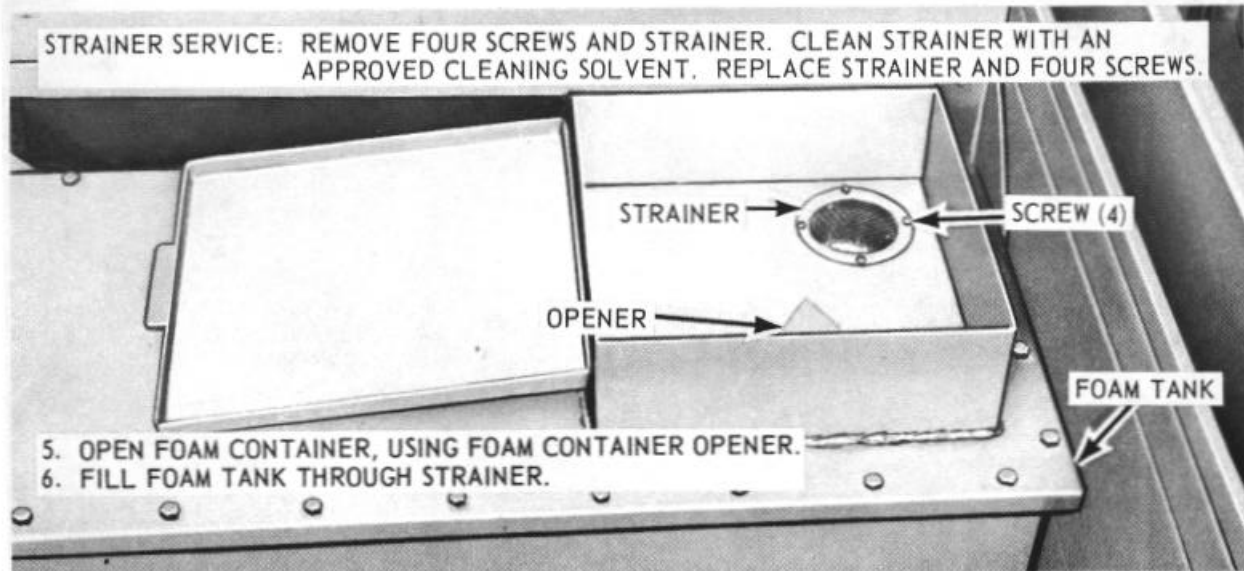

C

MSC 4210-205-12/11 (2)

B-Tank cover and overflow

C-Tank screen and opening

Figure 11-Continued.

1. MAKE SURE ALL VALVES AND CONTROLS ARE IN CLOSED POSITION.
2. OPEN FOAM TANK CONTROL VALVE.
3. OPEN FOAM CONTROL LEVER.
4. OPEN TANK FILL CONTROL LEVER.
5. OPEN FOAM METERING VALVE.
6. FILL AS INSTRUCTED ON FIGURE 11.

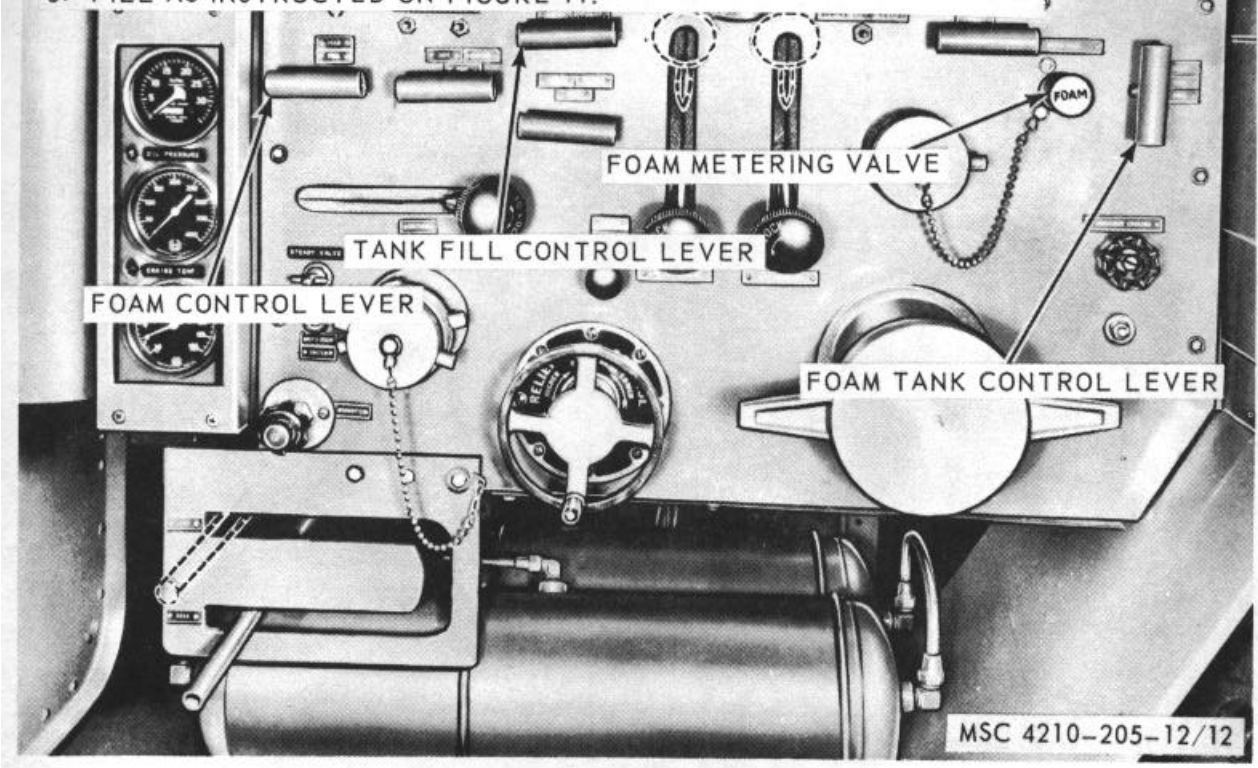
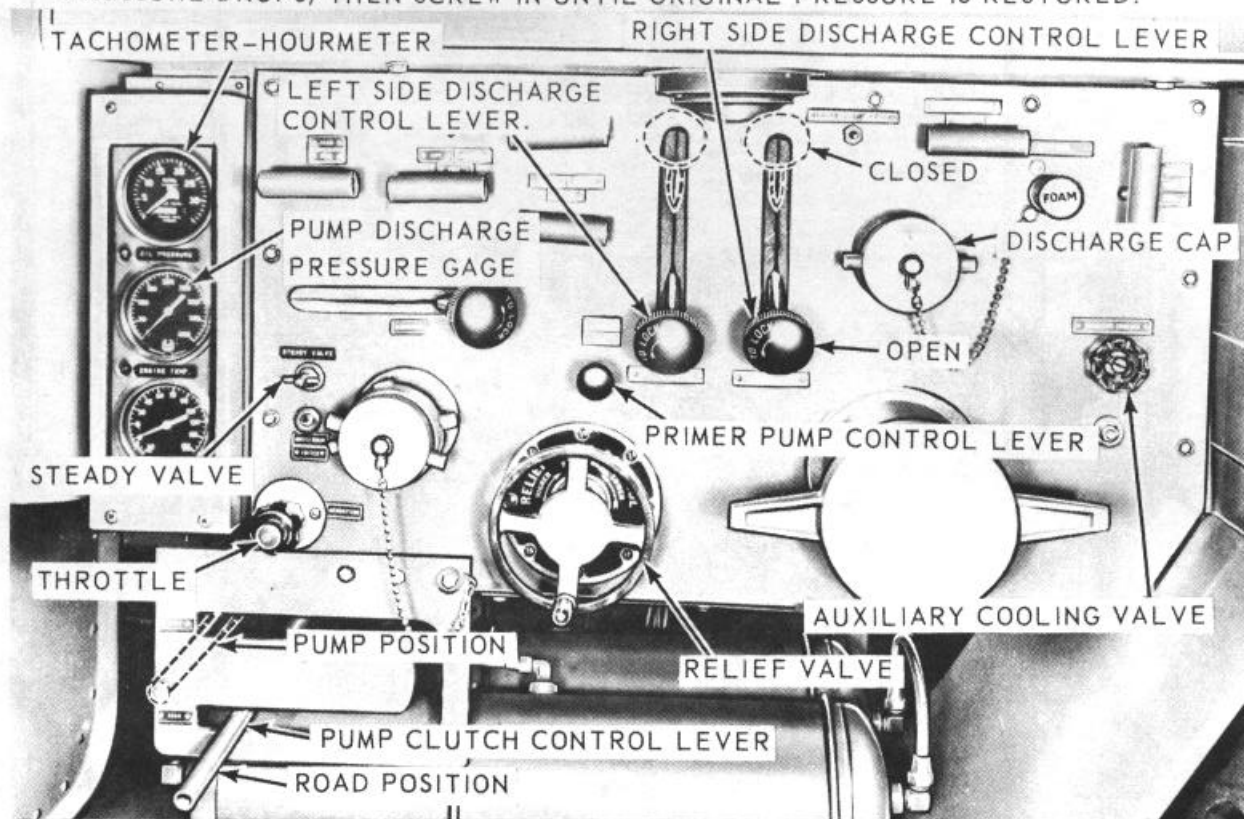

Figure 12. Foam tank and water tank filling with foam concentrate details.

1. WATER MAY BE PUMPED EITHER INDEPENDENTLY TO ONE, OR TO ALL OF THE OUTLETS AFTER REMOVING THE DISCHARGE CAPS AND CONNECTING HOSES.
2. GET AS CLOSE TO WATER AS POSSIBLE.
3. PRIME THE WATER PUMP FROM SUCTION LIFT (FIG. 7).
NOTE: MAKE SURE RELIEF VALVE WHEEL IS SCREWED IN AS FAR AS IT WILL GO.
4. MOVE PUMP CLUTCH CONTROL LEVER FROM ROAD TO PUMP POSITION, AND OPEN DISCHARGE VALVE OR VALVES.
5. OPEN STEADY VALVE AND THROTTLE GRADUALLY UNTIL DESIRED DISCHARGE PRESSURE IS REACHED AND REGULATE AUXILIARY COOLING VALVE TO COOL ENGINE.
6. SET RELIEF VALVE BY WATCHING PRESSURE GAGE AND BACKING OUT WHEEL UNTIL PRESSURE DROPS, THEN SCREW IN UNTIL ORIGINAL PRESSURE IS RESTORED.



7. IF WATER SHOULD CONTINUE TO FLOW OUT PRIMING PUMP DISCHARGE AFTER MAIN PUMP IS RUNNING, FLUSH PRIMING VALVE BY PULLING AND RELEASING PRIMING PUMP CONTROL LEVER SEVERAL TIMES.
 8. IF FOR CHANGING HOSE OR FOR ANY OTHER REASON A SHUT-DOWN IS DESIRED WHEN WORKING FROM LIFT, SIMPLY SLOW DOWN TO ABOUT 20 POUNDS ON ORDINARY LIFTS AND 35 POUNDS ON HIGH LIFTS AND CLOSE DISCHARGE VALVES. TO RESUME, SIMPLY OPEN THE DISCHARGE VALVES AND THROTTLE AND RESET RELIEF VALVE.
- WARNING: USE OF A NOZZLE TOO SMALL FOR THE PRESSURE CAN RUPTURE THE HOSE.
WARNING: WHEN WATER IS BEING PUMPED THROUGH THE DISCHARGE SYSTEM, AT LEAST TWO MEN SHOULD CONTROL THE HOSE AT THE NOZZLE TO PREVENT THE HOSE FROM WHIPPING AND CAUSING SERIOUS INJURY.

MSC 4210-205-12/13

Figure 13. Pumping water from suction lift.

1. WATER MAY BE PUMPED EITHER INDEPENDENTLY TO ONE, OR TO ALL OF THE OUTLETS AFTER REMOVING THE DISCHARGE CAPS AND CONNECTING HOSES.
2. PRIME THE WATER PUMP FROM HYDRANT (FIG. 7).
3. MOVE PUMP CLUTCH CONTROL LEVER FROM ROAD TO PUMP POSITION, AND OPEN DISCHARGE VALVE OR VALVES.
4. OPEN THROTTLE AND STEADY VALVE GRADUALLY UNTIL DESIRED PRESSURE IS REACHED AND REGULATE AUXILIARY COOLING VALVE TO COOL ENGINE.
5. SET RELIEF VALVE BY WATCHING PRESSURE GAGE AND BACKING OUT WHEEL UNTIL PRESSURE DROPS. THEN SCREW IN UNTIL ORIGINAL PRESSURE IS RESTORED.

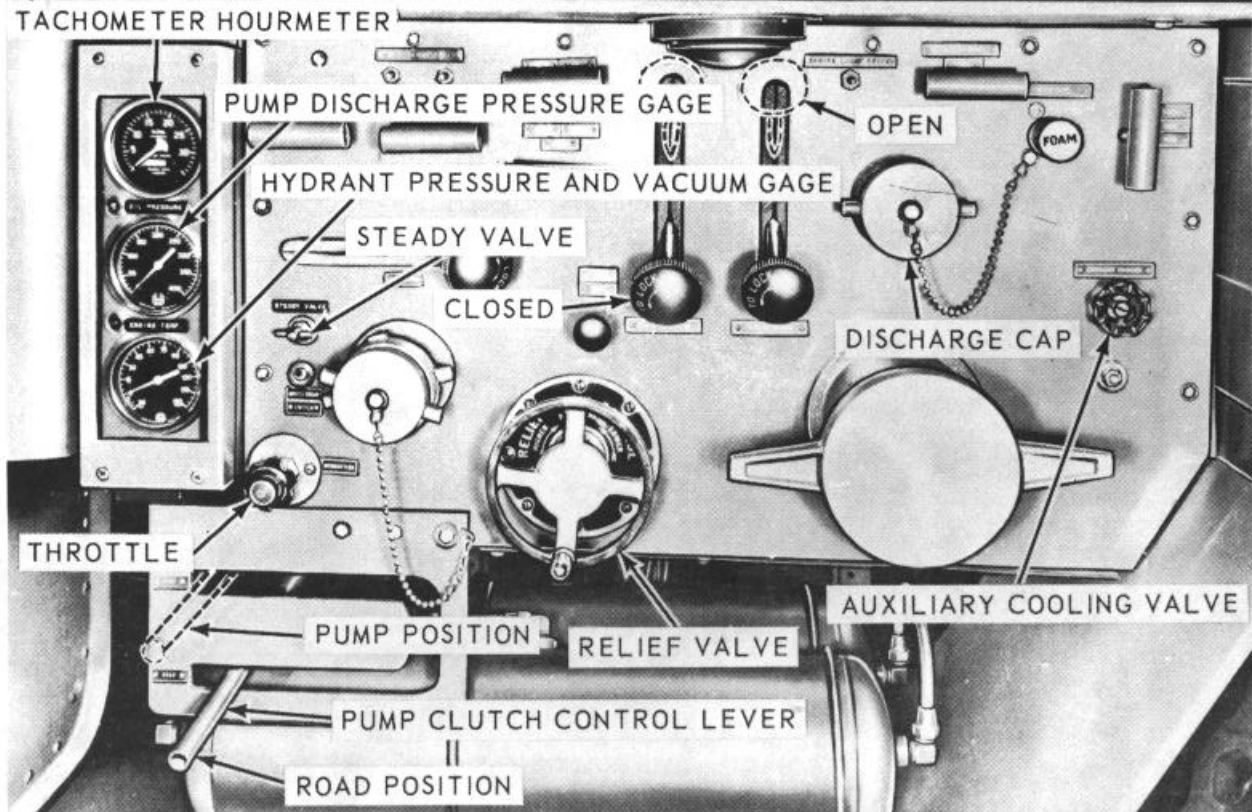

6. WATCH PRESSURE GAGE AS THROTTLE IS OPENED. IF ENGINE SPEED INCREASES WITHOUT PRESSURE GOING UP, YOU HAVE PASSED THE MOST EFFICIENT POINT OF OPERATION. CLOSE THROTTLE SLOWLY UNTIL THE PRESSURE BEGINS TO DROP AND THE ENGINE SPEED BECOMES REASONABLE.
CAUTION: MAKE SURE THE COMBINATION GAGE DOES NOT REGISTER BELOW 0 PSI. SERIOUS DAMAGE TO WATER MAINS MAY RESULT.
7. IF COMBINATION GAGE SHOWS VACUUM BEFORE DESIRED PRESSURE IS REACHED, THIS IS AN INDICATION THAT PUMP IS DRAWING ALL THE WATER HYDRANT WILL SUPPLY. USE SMALLER TIPS TO OBTAIN MORE PRESSURE.

MSC 4210-205-12/14

Figure 14. Pumping water from hydrant.

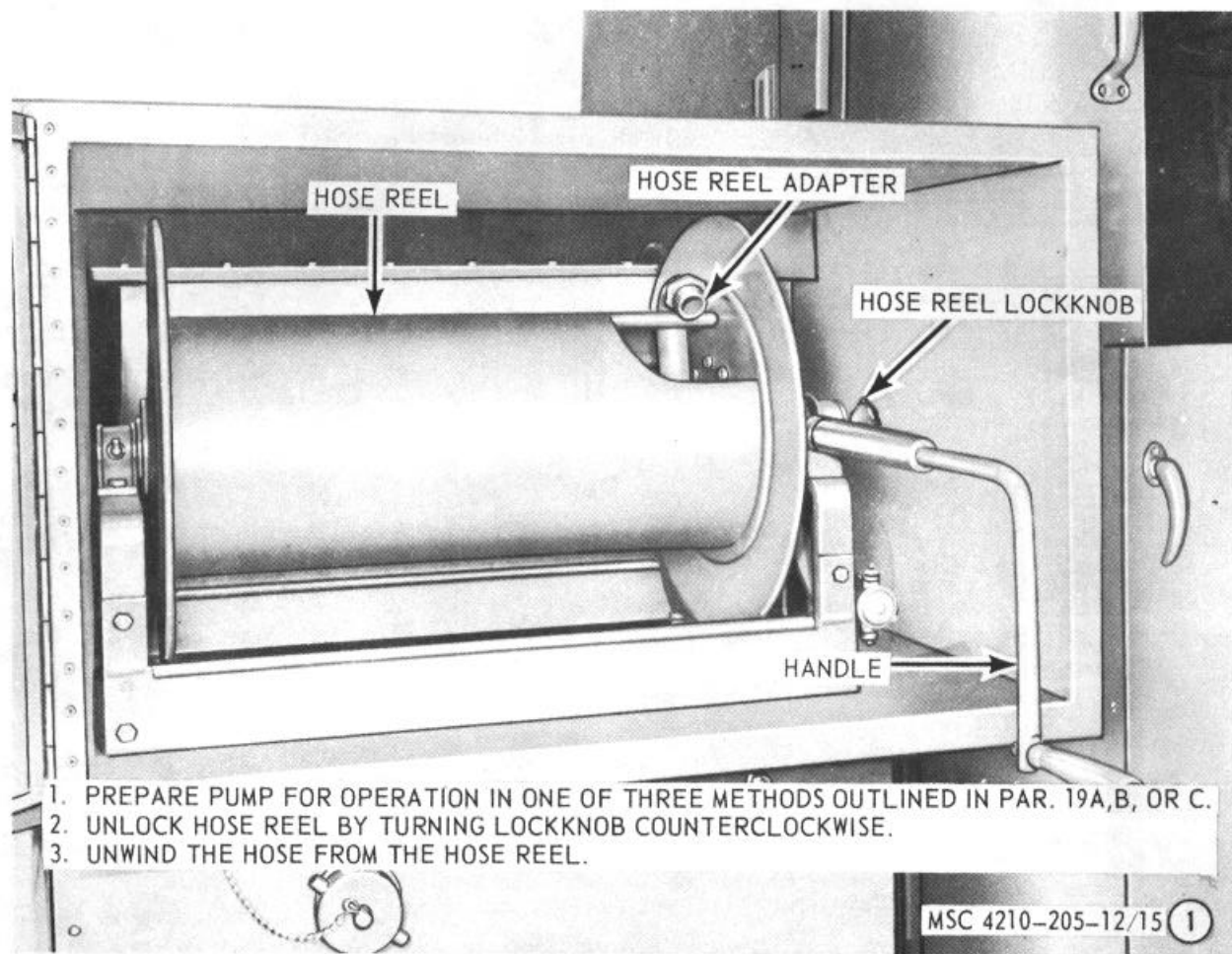

Figure 15. Pumping water from the hose reels.

22. Operation in Extreme Cold (Below 0° F.)

a. General. Operation in extreme cold temperatures creates special problems which require careful inspection and maintenance. Personnel should be especially careful not to subject the fire truck to any sudden shock loads or rough handling which might strain the equipment and crack or break metal parts. Do not allow water to spray over the body of the truck or the compartment doors carefully at slow speeds. All controls, linkage, frame mountings, and drive parts must be carefully inspected for damage. Refer to TM 9-2320-235-10 for additional information on operating the fire truck in extremely cold temperatures.

b. Lubrication. Be sure to use the correct grade of lubricant for all points of application. Refer to LO 9-2320-235-12 and LO 5-4210-205-12 for special cold weather lubrication instructions.

c. Hose Nozzles and Hoses. If the hose nozzles are closed in extremely cold weather, water in the hoses and nozzles freezes rapidly. Immediately after pumping, detach the nozzles and drain the hoses. If possible, dry the hoses before stowing to prevent freezing.

d. Pump, Lines. Drain water from pump and lines and leave drain open until all water is drained then close drain.

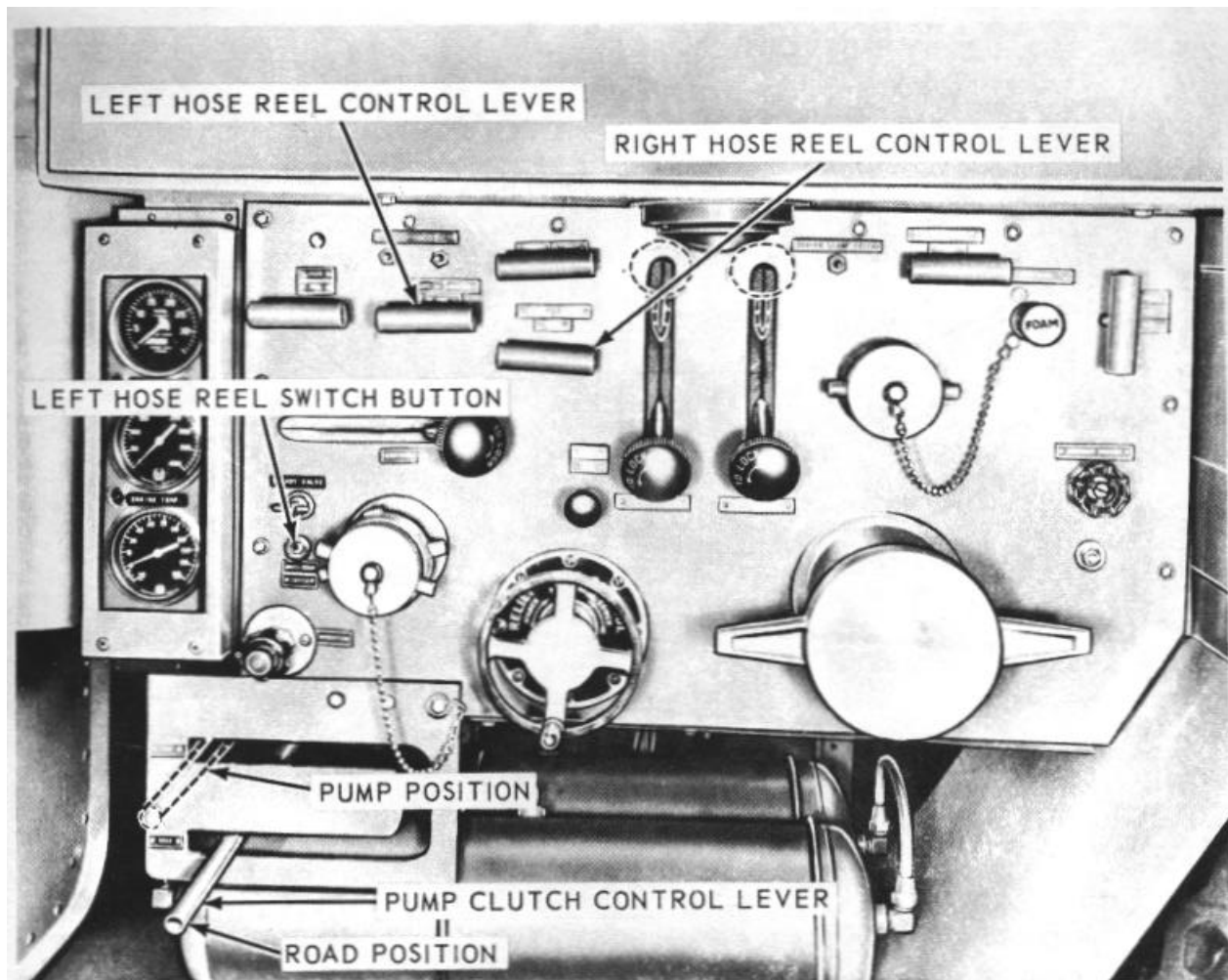

4. MOVE PUMP CLUTCH CONTROL LEVER FROM ROAD TO PUMP POSITION.
 5. OPEN THROTTLE AND STEADY VALVE UNTIL DESIRED PRESSURE IS REACHED AND REGULATE AUXILIARY COOLING VALVE TO COOL ENGINE.
 6. PULL OUT ON THE LEFT HOSE REEL CONTROL LEVER.
 7. AFTER PUMPING IS COMPLETE DRAIN THE HOSE, AND REWIND ON REEL BY PUSHING LEFT HOSE REEL REWIND SWITCH BUTTON.
- NOTE: PUMP WATER FROM THE RIGHT HOSE REEL IN A SIMILAR MANNER.
- NOTE: IN CASE OF FAULTY HOSE REEL MOTOR OR ELECTRICAL SYSTEM, HOSE REEL CAN BE OPERATED MANUALLY WITH THE HANDCRANK.
8. LOCK HOSE REEL BY TURNING LOCKKNOB CLOCKWISE.

MSC 4210-205-12/15 (2)

Figure 15-Continued.

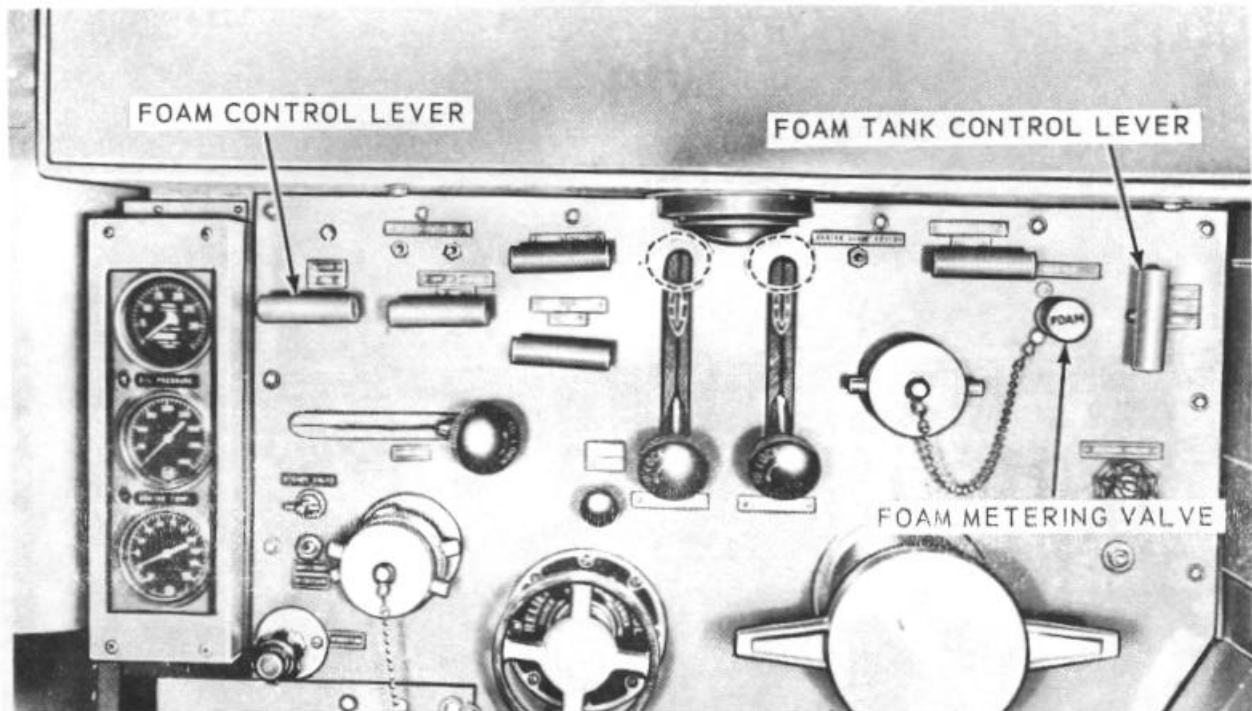

1. FILL THE FOAM TANK (PAR. 18E.).
2. PRESET THE METERING FOAM VALVE IN ACCORDANCE WITH FOAM METERING PLATE.
3. PREPARE THE PUMP FOR OPERATION IN ONE OF THREE METHODS OUTLINED IN PAR. 19 A, B, OR C.
4. OPEN THE FOAM TANK CONTROL LEVER.
5. OPEN THE FOAM CONTROL LEVER.
6. PUMP WATER AND FOAM FROM THE PUMP DISCHARGE LINE.
7. AFTER USE DRAIN AND FLUSH THE SYSTEM (PAR. 20).

MSC 4210-205-12/16

Figure 16. Pumping foam.

23. Operation in Extreme Heat

a. *General.* Refer to TM 9-2320 235-10 for additional information on operating the fire truck in extreme heat. Pumps are not affected by extreme heat, except for lubrication requirements.

b. *Lubrication.* Be sure to use the proper grade of lubricant for all points of application. Refer to LO 9-2320-235-12 and LO 5-210-205-12 for special lubrication. Check the lubricant level frequently.

24. Operation in Sandy or Dusty Areas

a. *Lubrication.* Keep all lubrication points clean and well lubricated. Lubricate sparingly but more frequently than under normal conditions. Clean all oily

or greasy surfaces, paying particular attention to the pump oil fill as it accumulates dust and sand. Service the air cleaners, breathers, and oil filters more frequently than under normal conditions (TM 9-2320-235-10).

b. *Cooling and Fuel Systems.* Service the radiator, fuel tank, and fuel filter (TM 9-2320-235-10).

c. *Pumps and Hose Reels.* Keep the body compartment doors closed except to perform necessary operations. Wipe the hose reel drive gears and drive chains to remove as much grease and oil from the exposed surfaces as possible. When dusty or sandy conditions no longer exist, remove the chains and wash with an approved cleaning solvent,

DRAINING AND FLUSHING TANK:

1. CLOSE THE FOAM METERING VALVE.
2. OPEN THE FOAM TANK DRAIN VALVE (FIG. 11).
3. MANUALLY RUN A SUFFICIENT QUANTITY OF WATER THROUGH THE TANK TO FLUSH THE REMAINING FOAM CONCENTRATE FROM THE TANK. CLOSE FOAM TANK DRAIN VALVE.

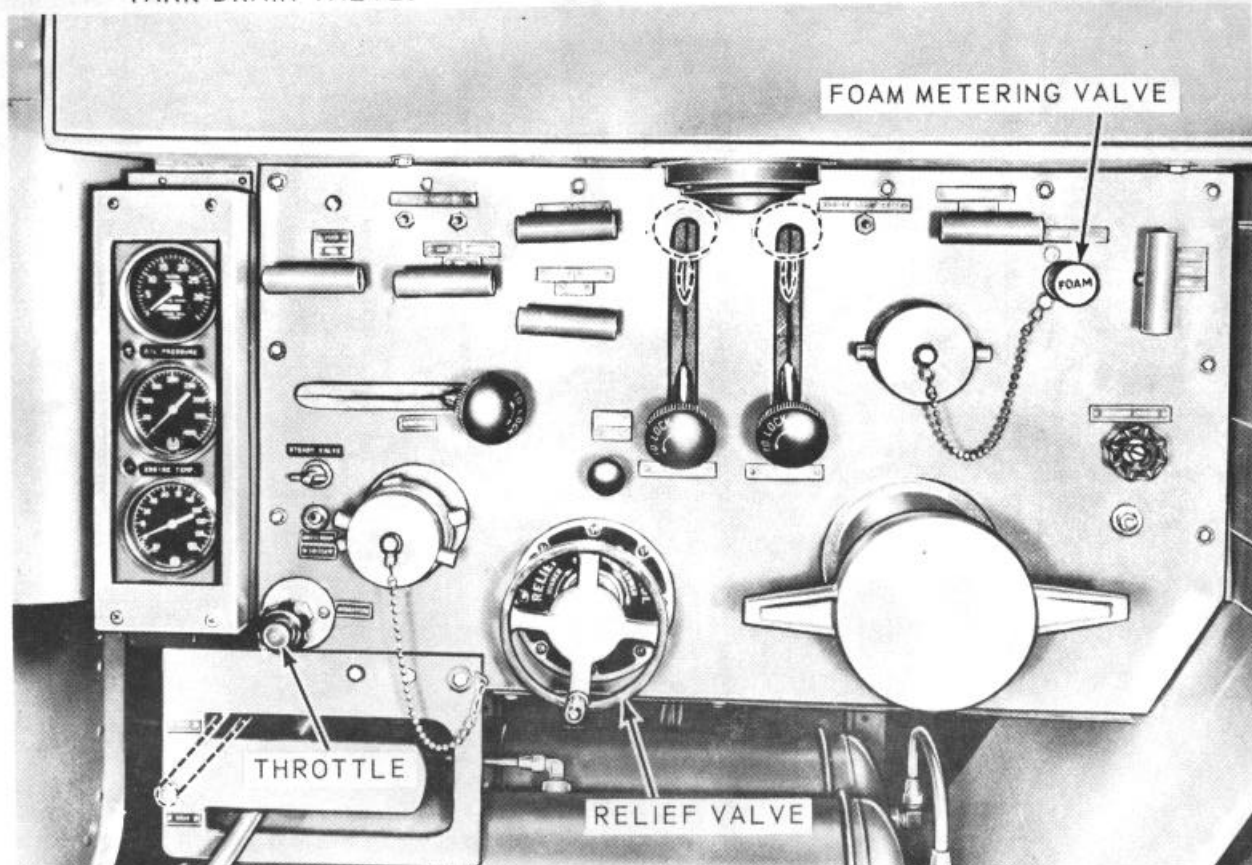

FLUSHING DISCHARGE LINE SYSTEM:

1. FLUSH TANK. THEN FILL WITH 10 GALLONS OF WATER.
2. START ENGINE (PAR. 16) AND REDUCE ENGINE SPEED WITH THROTTLE.
3. REDUCE PRESSURE IN RELIEF VALVE BY TURNING VALVE WHEEL COUNTER-CLOCKWISE.
4. OPEN FOAM METERING VALVE TO MAXIMUM.
5. PUMP WATER IN THE SAME MANNER AS DESCRIBED IN PAR. 19E.
6. ALLOW WATER TO RUN THROUGH THE TANK AND DISCHARGE SYSTEM UNTIL FOAM IS DEPLETED AND SHUT UNIT DOWN.
7. OPEN THE WATER PUMP AND LINES DRAIN VALVE (FIG. 7).

NOTE: ALWAYS FLUSH THE FOAM SYSTEM AS SOON AS IT IS DRAINED UNLESS IT IS TO BE IMMEDIATELY REFILLED. IF THE FOAM SYSTEM IS NOT FLUSHED, DAMAGE WILL RESULT AND RENDER THE SYSTEM INOPERATIVE.

MSC 4210-205-12/17

Figure 17. Draining and flushing foam concentrate tank and discharge line system.

lubricate, and reinstall. Clean all the machined surfaces of the pump and control linkages to remove accumulated dust and sand.

d. *Electrical Systems.* Keep the insulation electrical connections, and all motors free from dust and sand to prevent wear and short circuits. Cover the siren when not in use.

25. Operation Under Rainy or Humid Conditions

a. *General.* High humidity causes a rusting and corrosive action to exposed metal surfaces with oil or grease.

b. *Fuel System.* Keep the fuel tank as full as possible to eliminate condensation. Clean the fuel line sediment bowl daily (TM 9-2320-235-10).

c. *Electrical System.* Keep the electrical system clean and dry. Wipe off any excess moisture. Pay particular attention to electrical connections.

26. Operation in Salt Water Areas

a. *General.* The deterioration and corrosion of

exposed metal is greatly accelerated in salt water areas. Coat all exposed metal surfaces with an approved lubricant. When the fire truck has been partly immersed or sprayed with salt water, wash down with fresh water.

b. *Pumping Salt Water.* Do not use salt water except in case of extreme emergency. At the earliest opportunity after pumping salt water, flush the tank piping and fire pump thoroughly with fresh water. After flushing, drain the water pump.

27. Operation at High Altitude

a. *General.* Operation at high altitude presents special problems due to lower atmospheric pressure and wide differences in temperature, which occurs during the day and night. Protect the fire truck at all times from the lowest anticipated temperature.

b. *Cooling System.* Keep the cooling system clean and filled to the proper level. Inspect frequently as water evaporates more rapidly at high altitudes. Keep the radiator clean and engine compartment doors and radiator shutters open when in operation.

Section V. OPERATION OF AUXILIARY MATERIEL USED IN CONJUNCTION WITH FIRE TRUCK

28. Carbon Dioxide and Carbon Tetrachloride Type Fire Extinguishers

a. *Carbon Dioxide Type.*

(1) *Description.* The carbon dioxide fire extinguisher is suitable for use on electrical and flammable fires. The carbon dioxide type is of the 15-pound size. The 15-pound extinguisher is portable.

(2) *Operation.* Remove the fire extinguisher from its location, break the seal, operate the control valve, and direct the stream at the base of the flame.

(3) *Refilling and Maintenance.* For detailed information on refilling and maintenance, refer to TM 5-687 and TM 9-1799.

b. *Carbon Tetrachloride Type.*

(1) *Description.* The carbon tetrachloride type fire extinguisher is suitable for electrical fires because it will not damage electrical equipment or conduct electricity. It is a 1-quart, vaporizing-liquid, pump operated extinguisher.

(2) *Operation.* Remove fire extinguished from

its location; turn the handle and work the handle like a pump. Direct the stream at the base of flame.

Warning

Be extremely careful when using a carbon tetrachloride fire extinguisher in an enclosed area. Provide adequate ventilation before entering an enclosed area where carbon tetrachloride has been used.

(3) *Maintenance.* For maintenance of the fire extinguisher, refer to TM 5-687 and TM 9-1799.

29. Monobromotrifluoromethane and Foam Type Fire Extinguishers

a. *Monobromotrifluoromethane Type.*

(1) *Description.* The monobromotrifluoromethane type fire extinguisher is generally suitable for all types of fire, except fire involved with LOX (liquid oxygen) generating equipment. The fire extinguisher is furnished with a disposable type cylinder.

(2) *Operation.* To operate the fire extinguisher, perform the following:

- its location.
- (a) Remove fire extinguisher from
from handle.
- (b) Break seal by pulling safety pin
- (c) Point horn at base of flame.
- (d) Press trigger for discharge and
direct stream at base of flame.
- (e) Replace cylinder immediately
after using.

(3) *Replacement of Cylinder.* To replace
cylinder, perform the following:

- (a) Press lever to release pressure
from used cylinder.
- (b) Loosen swivel valve coupling
nut and remove valve assembly from used cylinder.
- (c) Remove instruction band from
used cylinder.
- (d) Place new cylinder through
instruction band.
- (e) Replace safety pin in valve and
seal pin with sealing wire.

(f) Attach valve assembly and
tighten swivel coupling nut on the new cylinder and
place fire extinguisher in mounting bracket.

(g) Adjust instruction band on
cylinder to show maintenance and operating
instructions.

(4) *Maintenance.* Weigh fire extinguisher
every 3 months, and replace cylinder if gross weight has
decreased 4 ounces or more. Lubricate cylinder neck
threads with one drop of OE 30 oil before reassembly.

b. *Foam Type.*

(1) *Description.* The foam type fire
extinguisher is similar in size and appearance to the
soda-acid extinguisher but differs in internal construction
and extinguishing agent.

(2) *Operation.* Remove the foam
extinguisher from its location. Invert the fire
extinguisher permitting the contents of the two
chambers to mix, and flow from the hose.

(3) *Refilling and Maintenance.* For
detailed instructions on refilling and maintenance, refer
to TM 5-687 and TM 9-1799.

CHAPTER 3

OPERATOR AND ORGANIZATIONAL MAINTENANCE INSTRUCTIONS

Section I. OPERATOR AND ORGANIZATIONAL MAINTENANCE TOOLS AND EQUIPMENT

30. Special Tools or Equipment

There are no special tools or equipment used by the operator or by organizational maintenance personnel for performing maintenance on the fire truck.

31. Basic Issue Tools and Equipment

Tools and repair parts issued with or authorized for the fire truck are listed in the basic issue items list, appendix III.

Section II. LUBRICATION

32. General Lubrication Information

a. This section contains a reproduction of the lubrication order and lubrication instructions which are supplemental to and are not specifically covered in the lubrication order.

b. The lubrication order, shown on figure 18, is an exact reproduction of the approved lubrication order for the fire truck. Refer to LO 9-2320-235-12 for lubrication of the fire truck engine and chassis. For the current lubrication order, refer to DA Pam 310-4.

33. Detailed Lubrication Information

a. General. Refer to LO 9-2320-235-12 for additional detailed lubrication information.

b. Care of Lubricants. Store lubricants in covered containers that will protect them from dirt, water, and foreign material. Keep all lubrication equipment clean and ready for use.

c. Cleaning. Clean all points of lubrication with an approved cleaning solvent before lubricating.

d. Points of Application. Follow the instructions and apply the lubricants as prescribed. It is recommended that the fire truck and each of the components be lubricated while warm from operation. Over lubrication may cause equipment failure, damage to working parts, and erratic operation.

e. Operation after Lubrication. Operate the fire truck engine for 5 minutes after hanging oil and lubricating.

**LUBRICATION
ORDER**

LO 5-4210-205-12

12 OCTOBER 1964

**TRUCK, FIRE FIGHTING: POWERED PUMPER; FOAM AND WATER
500 G.P.M. CAP.; CENTRIFUGAL PUMP, POWER TAKE OFF
DRIVEN; 400 GAL. WATER TANK, 40 GAL. FOAM
CHEMICAL TANK (WARD LAFRANCE
MODEL M44A1WLF)**

Reference: TM5-4210-205-12, LO 9-2320-235-10, C 9100 SL

Intervals are based on normal hours of operation. Reduce to compensate for abnormal operations and severe conditions. During inactive periods sufficient lubrication must be performed for adequate preservation.

Clean parts with SOLVENT, dry-cleaning, or with OIL, fuel, Diesel. Dry before lubricating.

Relubricate after washing.

Clean fittings before lubricating.

Drain gear cases when hot. fill and check level.

A dotted circle indicates a drain below.

Lubricate points indicated by dotted arrow shafts on both sides of equipment.

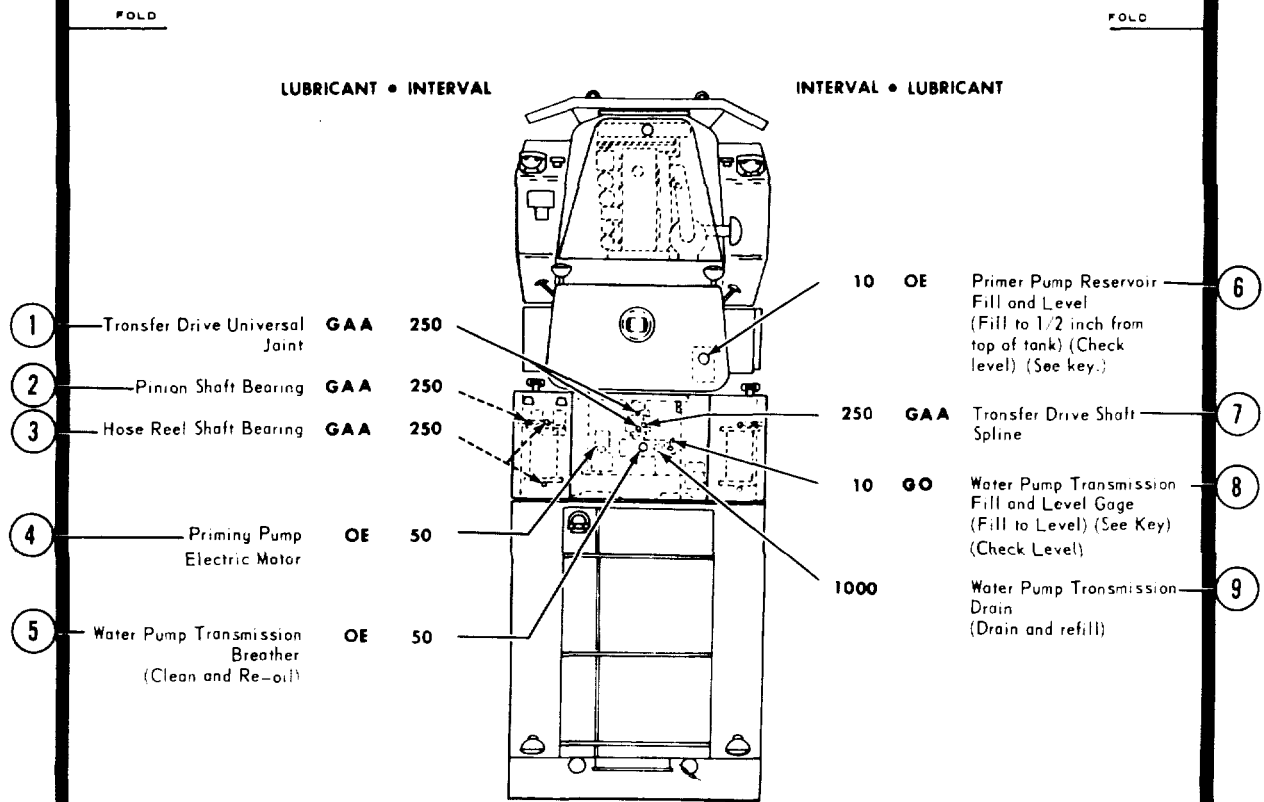

MSC 4210-205-12/18

Figure 18. Lubrication order.

- KEY -

LUBRICANTS	CAPACITY	EXPECTED TEMPERATURES			INTERVALS
		Above +32°F	+40°F to -10°F	0°F to -65°F	
OE-OIL, Engine, Heavy Duty		OE 30 or 9250	OE 10 or 9110	OES	Intervals given are in hours of normal operation
Primer Pump Reservoir	6 qt.				
Oil Can Points					
OES-OIL, Engine, Sub-zero		GO 90	GO 90	GOS	
GO -LUBRICATING OIL, Gear					
Water Pump Transmission	2 qt.				
GOS-LUBRICATING OIL, Gear, Subzero		ALL TEMPERATURES			
GAA-GREASE, Automotive and Artillery		ALL TEMPERATURES			

1. FOR OPERATION OF EQUIPMENT IN PROTRACTED COLD TEMPERATURES BELOW -10°F. Remove lubricants prescribed in the key for temperatures above -10°F. Clean parts with SOLVENT, dry-cleaning. Relubricate with lubricants specified in the key for temperatures below -10°F.

2. OIL CAN POINTS. Every 50 hours clean and lightly coat door hinges, latches, throttle and clutch controls with OE.

Copy of this Lubrication Order will remain with the equipment at all times, instructions contained herein are mandatory.

By Order of the Secretary of the Army:

HAROLD K. JOHNSON,
General, United States Army,
Chief of Staff.

Official:
J. C. LAMBERT,
Major General, United States Army,
The Adjutant General.

FOLD

FOLD

MSC 410-205-12-18 (2)

Figure 18-Continued.

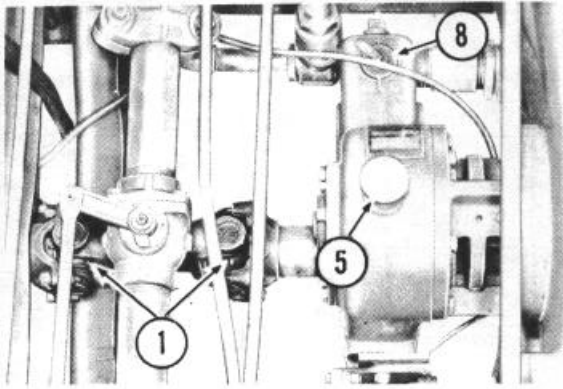

REF. 1 TRANSFER DRIVE UNIVERSAL JOINT
 REF. 5 WATER PUMP TRANSMISSION BREATHER
 REF. 8 WATER PUMP TRANSMISSION FILL AND LEVEL GAGE

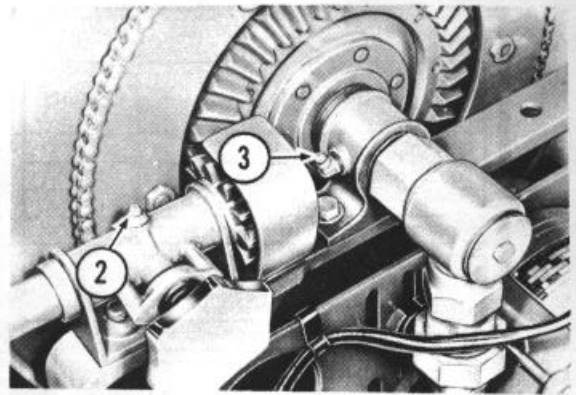

REF. 2 PINION SHAFT BEARING
 REF. 3 HOSE REEL SHAFT BEARING

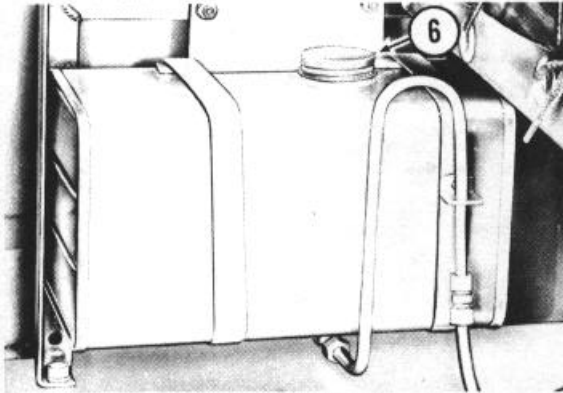

REF. 6 PRIMER PUMP RESERVOIR FILL AND LEVEL

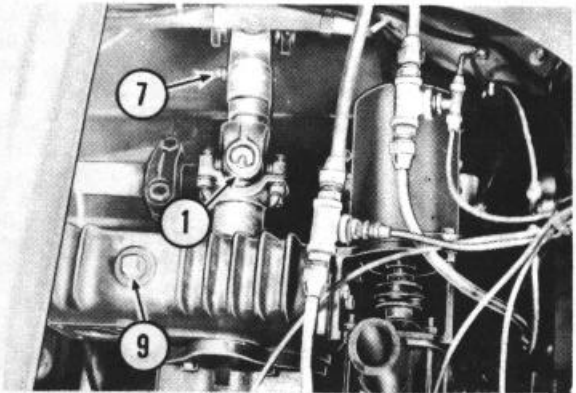

REF. 1 TRANSFER DRIVE UNIVERSAL JOINT
 REF. 7 TRANSFER DRIVE SHAFT SPLINE
 REF. 9 WATERPUMP TRANSMISSION DRAIN

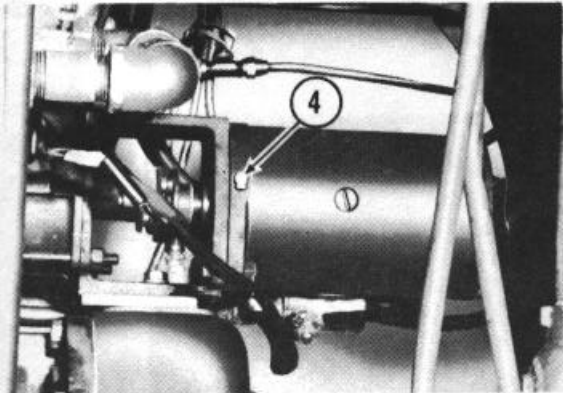

REF. 4 PRIMING PUMP ELECTRIC MOTOR

MSC 4210-205-12/18 ③

Figure 18-Continued.

Section III. PREVENTIVE MAINTENANCE SERVICES

34. General

To insure that the fire truck is ready for operation at all times, it must be inspected systematically, so that defects may be discovered and corrected before they result in serious damage or failure. The necessary preventive maintenance services to be performed are listed and described in paragraphs 35 and 36. The item numbers indicate the sequence of minimum inspection requirements. Defects discovered during operation of the unit will be noted for future correction, to be made as soon as operation has ceased. Stop operation immediately if a deficiency is noted during operation which would damage the fire truck if operation were continued. All deficiencies and shortcomings will be recorded, together with the corrective action taken, on DA Form 2404 at the earliest possible opportunity.

35. Daily Preventive Maintenance Services

This paragraph contains an illustrated tabulated listing of preventive maintenance services which must be performed by the operator. The item numbers are listed consecutively and indicate the sequence of minimum requirements. Refer to figure 19 for the daily preventive maintenance services.

36. Quarterly Preventive Maintenance Services

a. This paragraph contains an illustrated tabulated listing of preventive maintenance services which must be performed by organizational maintenance personnel at quarterly intervals. A quarterly interval is equal to 3 calendar months or 250 hours of operation, whichever occurs first.

b. The item numbers are listed consecutively and indicate the sequence of minimum requirements. Refer to figure 20 for quarterly preventive maintenance services.

PREVENTIVE MAINTENANCE SERVICES DAILY

TM 5-4210-205-12

TRUCK, FIRE FIGHTING

WARD LAFRANCE MODEL M44A1WLF

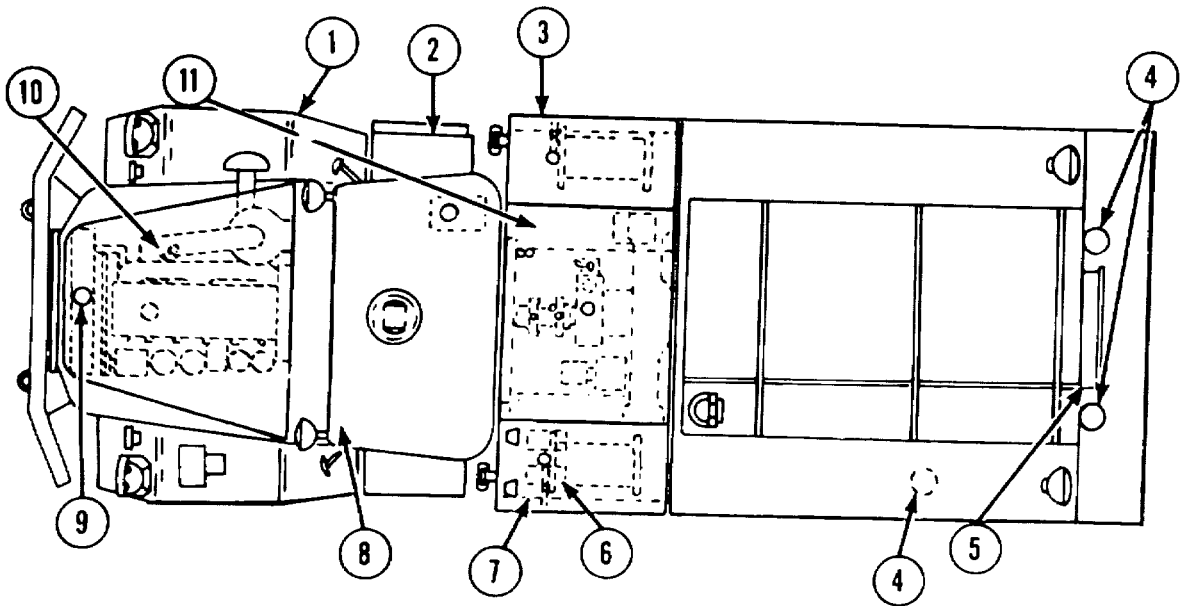

LUBRICATE IN ACCORDANCE WITH CURRENT LUBRICATION ORDER

ITEM		PAR. REF
1	<u>TIRES.</u> Perform visual check for proper inflation.	
2	<u>BATTERIES.</u> Check electrolyte level and hand tightness of connections. Fill to 3/8 inch above the plates (weekly). In freezing weather run engine one hour after adding water.	
3	<u>FUEL TANK.</u> Check fuel level.	
4	<u>FIRE EXTINGUISHERS.</u> Inspect for broken seal.	

Figure 19. Daily preventive maintenance services.

ITEM		PAR. REF
5	<u>WATER TANK.</u> Check water level. Fill to below tank overflow.	
6	<u>AIR SYSTEM.</u> Drain condensation from air tanks.	
7	<u>PUMPING STATION INSTRUMENTS.</u> Normal readings are: Tachometer – 1550 to 1980 rpm, Oil pressure lamp – out with engine running. Pump discharge pressure – 120 to 250 psi, Engine temperature lamp – out with engine running.	
8	<u>INSTRUMENTS.</u> Normal readings are: Oil pressure – 30 to 40 psi at idle speed, 45 to 50 psi at normal operating speed, Temperature – 160° to 180°F, Battery generator indicator – in charge area, Air pressure – 85 to 105 psi.	
9	<u>COOLING SYSTEM.</u> Check coolant level. Fill to the level cock.	
10	<u>ENGINE OIL LEVEL.</u> Check oil level. Add oil to proper level.	
11	<u>FOAM CONCENTRATE TANK.</u> Check foam concentrate level. Fill to capacity. Flush foam system when drained unless refilling immediately.	
	<u>NOTE: OPERATION.</u> During operation check all controls for proper operation.	

MSC 4210-205-12/19

Figure 19-Continued.

PREVENTIVE MAINTENANCE SERVICES QUARTERLY

TM 5-4210-205-12

TRUCK, FIRE FIGHTING

WARD LAFRANCE MODEL M44A1WLF

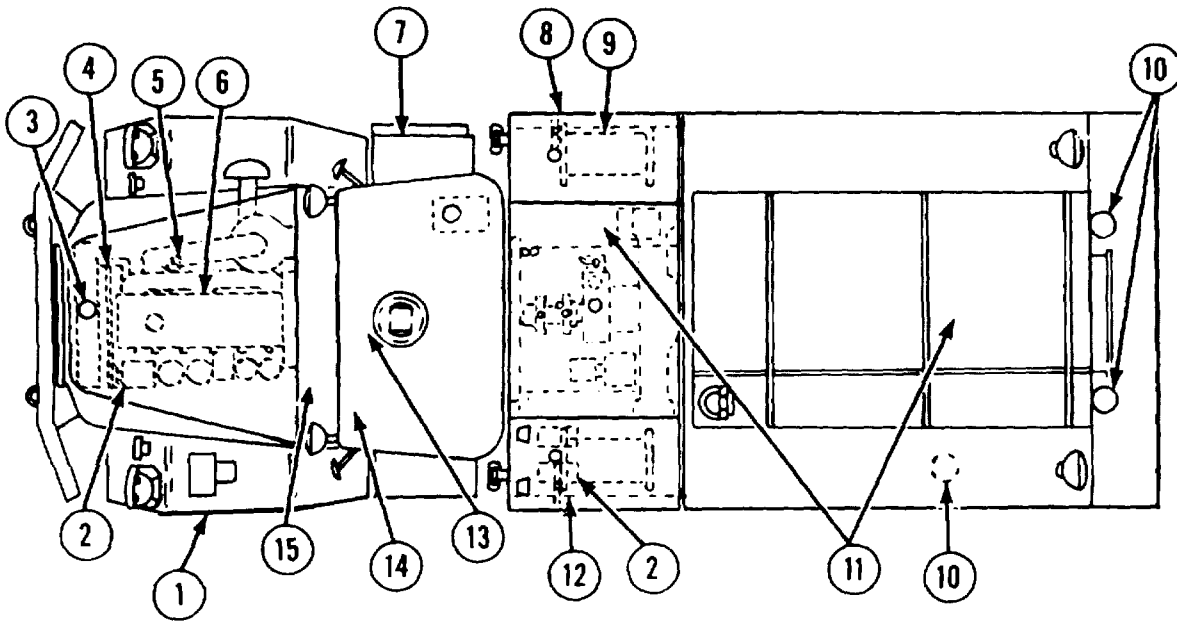

LUBRICATE IN ACCORDANCE WITH CURRENT LUBRICATION ORDER

ITEM	PAR. REF	
1	<u>TIRES.</u> Inspect for wear, cuts, bruises, and proper inflation. Tire pressure is 70 psi.	
2	<u>AIR SYSTEM.</u> Inspect for leaks, loose mounting, and proper operation. Drain condensation from air tanks.	
3	<u>COOLING SYSTEM.</u> Check coolant level. Fill to level cock. Check for correct antifreeze solution. Clean radiator air passages. Correct coolant leaks.	
4	<u>BELTS.</u> Inspect for wear and proper adjustment. Correct tension is 1/2 inch deflection midway between pulleys.	

Figure 20. Quarterly preventive maintenance services.

ITEM		PAR. REF
5	<u>LUBRICATING SYSTEM.</u> Check engine oil level. Add oil to correct level. Correct lubricant leaks. Lubricate in accordance with current LO.	
6	<u>VALVE ADJUSTMENT.</u> Check valve adjustment 0.015 intake 0.025 exhaust.	
7	<u>ELECTRICAL SYSTEM.</u> Check battery electrolyte level. Check generator and regulator for proper operation. Check generator brushes, overall length should not be less than 7 16 inch. (1000 hours). Check starter for proper operation. Tighten all loose connections and replace defective wiring.	
8	<u>FUEL SYSTEM.</u> Correct fuel leaks. (1000 hours)	
9	<u>HOSE REELS.</u> Inspect for loose mounting and proper operation. Unreel the hose and inspect for cuts, fraying, and deterioration.	
10	<u>FIRE EXTINGUISHERS.</u> Inspect for broken seal, full charge, and loose mounting.	
11	<u>WATER AND FOAM TANKS.</u> Inspect for leaks and loose mounting.	
12	<u>PUMPING STATION CONTROLS AND INSTRUMENTS.</u> Inspect for loose mounting, connections, and proper operation. Normal readings are: Tachometer – 1550 – 1980 rpm, Oil pressure lamp – out with engine running; Pump discharge pressure – 120 to 250 psi; Engine temperature lamp – out with engine running.	
13	<u>CLUTCH, TRANSMISSION, AND DIFFERENTIALS.</u> Check clutch for proper operation and adjustment. Adjustment should be 3/4 inch free travel. Inspect transmission and differentials for leaks. (1000 hours)	
14	<u>BRAKES.</u> Check for proper operation and adjustment. Adjustment should be from 1 1/2 to 2 inches free travel. Check fluid level in master cylinder. Add fluid to filler neck.	

Figure 20-Continued.

ITEM		PAR. REF
15	<p><u>INSTRUMENTS.</u> Inspect for loose mounting and connections and proper operation. Normal readings are: Oil pressure – 30 to 40 psi at idle speed, 45 to 50 psi at normal operating speed, Temperature – 160° to 180°F, Battery generator indicator – In charge area, Air pressure – 85 to 105 psi.</p>	
	<p><u>NOTE: OPERATIONAL TEST.</u> During operation check for unusual noise or vibration and proper operation.</p>	

MSC 4210-205-12/20

Figure 20-Continued.

Section IV. TROUBLESHOOTING

37. General

This section provides information useful in diagnosing and correcting unsatisfactory operation or failure of the fire truck and its components. Each trouble symptom stated is followed by a list of probable causes of the trouble. The possible remedy recommended is described opposite the probable cause. Any trouble beyond the scope of organizational maintenance will be reported to direct support maintenance.

38. Water Pump Capacity Drops

<i>Probable cause</i>	<i>Possible remedy</i>
Speed too low.	Adjust throttle.
Water pump loses prime.	Clean dirty or replace damaged water line suction screens. Check for air leaks. Submerge suction at deeper supply point. Reprime pump (para. 18).
Fire truck too high to permit pump suction.	Change position of fire truck.
Water lines loose or defective.	Tighten or replace lines.

39. Water Pump Fails To Deliver Water Upon Starting

<i>Probable cause</i>	<i>Possible remedy</i>
Positive suction lacking.	Inspect for air leaks in the suction lines or at the suction hose strainer when pumping from draft. See that suction hose is 2 feet below surface of open water. Reprime (para. 18).
Lift required beyond pumps capacity.	Draw supply from different source or change position of fire truck.
Water discharge valve closed.	Open water discharge valve.
Discharge head requires higher pump speed.	Increase engine speed.

40. Pump Clutch Lever Is Hard or Impossible to Engage

<i>Probable cause</i>	<i>Possible remedy</i>
Improper linkage or clutch adjustment.	Adjust clutch or linkages as necessary (para. 126).
Disconnected, worn, or bent linkage.	Connect, repair, or replace faulty parts (para. 126).

41. Water Pump Vibrates or Becomes Noisy

<i>Probable cause</i>	<i>Possible remedy</i>
Cavitation occurring.	Check suction pressure. Relocate suction strainers when pumping from draft. Reprime the pump (para. 18).
Pump vapor bound and not fully loaded.	Temporarily reduce speed or partially close discharge valve.

42. Foam Pump Fails To Deliver Adequate Foam Discharge

<i>Probable cause</i>	<i>Possible remedy</i>
Foam concentrate supply is exhausted.	Refill foam tank (para. 18):
Foam concentrate tank valve is in closed position.	Open valve (para. 18).
Improperly adjusted foam proportion regulating valve.	Adjust foam proportion regulating valve (para. 19).

43. Foam Does Not Have Proper Characteristics For Effective Use

<i>Probable cause</i>	<i>Possible remedy</i>
Improperly adjusted foam proportion regulating valve.	Adjust foam proportion regulating valve (para. 19).
Change in characteristics of water regarding mineral content,	Adjust foam proportion regulating valve to components (para. 19).
Improper nozzle.	Change nozzle.
Foam concentrate liquid supply is diluted or contaminated.	Drain and flush foam system. Fill with concentrate of proper quality (para. 20).

44. Hose Reel Assemblies Stick and Bind When Reeling or Unreeling Hose

<i>Probable cause</i>	<i>Possible remedy</i>
Insufficient lubrication of hose reel shaft bearings or badly worn bearings.	Lubricate as specified in LO 5-4210-205-12 and replace a badly worn bearing. Report to direct, general support, and depot maintenance.
Hose reel assemblies damaged or defective.	Replace hose reel (para. 123).

45. Hose Reel Assemblies Inoperative

<i>Probable cause</i>	<i>Possible remedy</i>
Motor solenoid relay defective.	Replace relay (para. 103).
Hose reel switch defective.	Replace switch (para. 102).
Hose reel assemblies damaged or defective.	Replace hose reel (para. 123).

Hose reel motor defective. Tighten loose wiring connections. Replace defective motor (para. 104).

46. Siren Inoperative

<i>Probable cause</i>	<i>Possible remedy</i>
Wiring defective.	Tighten loose connections and replace wiring as necessary (para. 80).
Siren hand switch defective.	Replace defective hand switch (para. 94).
Defective siren.	Replace or repair defective siren (para. 82).

47. Spotlight, Floodlights or Warning Lights Inoperative

<i>Probable cause</i>	<i>Possible remedy</i>
Wiring defective.	Tighten loose connections and replace wiring as necessary (para. 80).
Beacon warning light switch defective.	Replace defective beacon warning light switch (para. 91).
Rear floodlight defective.	Replace defective rear floodlight (para. 108).
Beacon warning light defective.	Replace or repair defective beacon warning light (para. 84).
Spotlight defective.	Replace defective spotlight (para. 83).

Section V. FIELD EXPEDIENT REPAIRS

48. Field Expedient Repairs

Organizational maintenance troubles may occur while the Ward Lafrance Model M44A1WLF Fire Truck is operating in the field where supplies and repair parts are not available and normal corrective action cannot be performed. When this condition exists, the following expedient repairs may be used in emergencies, upon the decision of the unit commander. Equipment so repaired must be removed from operation as soon as possible and properly repaired before being placed in operation again.

49. Transfer Case Lever Disengages

<i>Trouble</i>	<i>Expedient remedy</i>
Control lever will not stay in desired position.	Wedge, block, or tie the control lever in the desired position.

50. Loss of Water or Foam

<i>Trouble</i>	<i>Expedient remedy</i>
Hole in water or foam tank.	Plug hole with wooden plug or metal screw.

Section VI. RADIO INTERFERENCE SUPPRESSION

51. General Methods Used To Attain Suppression

Essentially, suppression is attained by providing a low resistance path to ground for stray currents. The methods used include shielding the ignition and high-frequency wires, grounding the frame with bonding straps, and using capacitors and resistors. For general information on radio interference suppression, see TM 11-483.

52. Interference Suppression Components

a. Primary Suppression Components.

(1) *Capacitors.* The fire truck has four capacitors located on the turn signal flasher, siren, siren flasher, and beacon warning light. The capacitors

are illustrated on figure 21.

(2) *Ground strap.* The unit has four ground straps, two from chassis to frame and one each located on the frame to hose motor assemblies. The ground straps are illustrated on figure 21.

(3) *Secondary Suppression Components.* Tooth-type lockwashers are used to assure good metal-to-metal contact where electrical components are mounted.

53. Replacement of Suppression Components

a. *Primary Suppression Components.* Replace radio interference components with new components

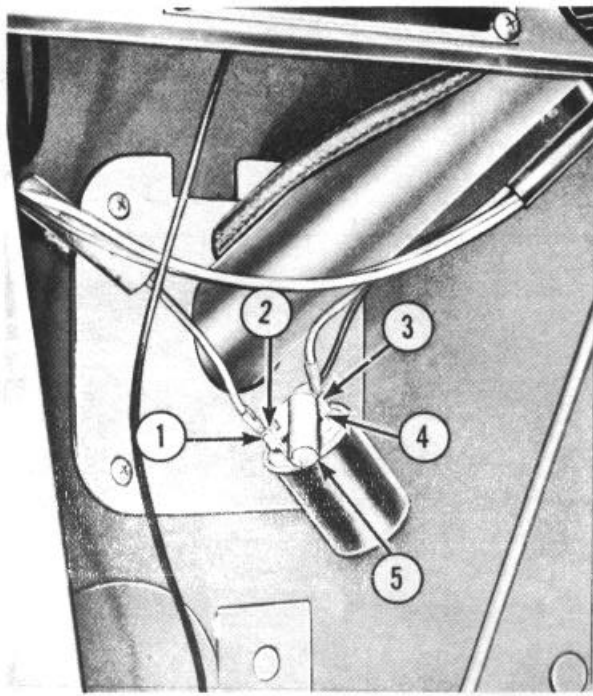

A

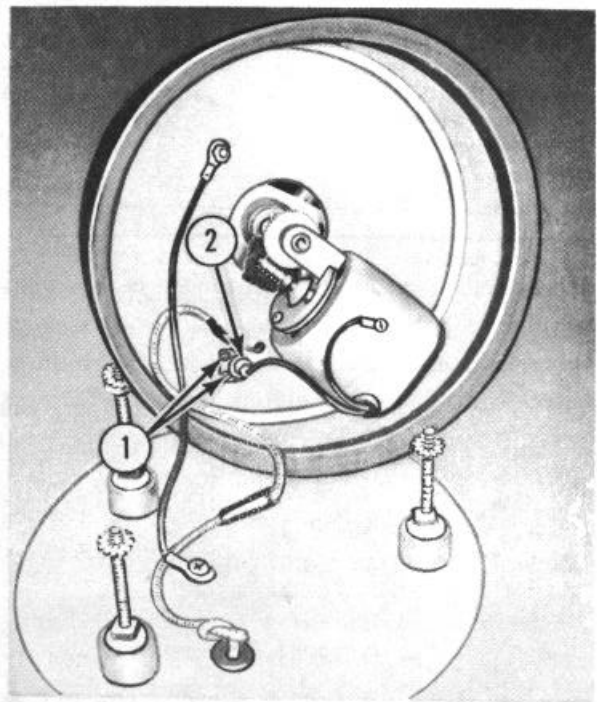

B

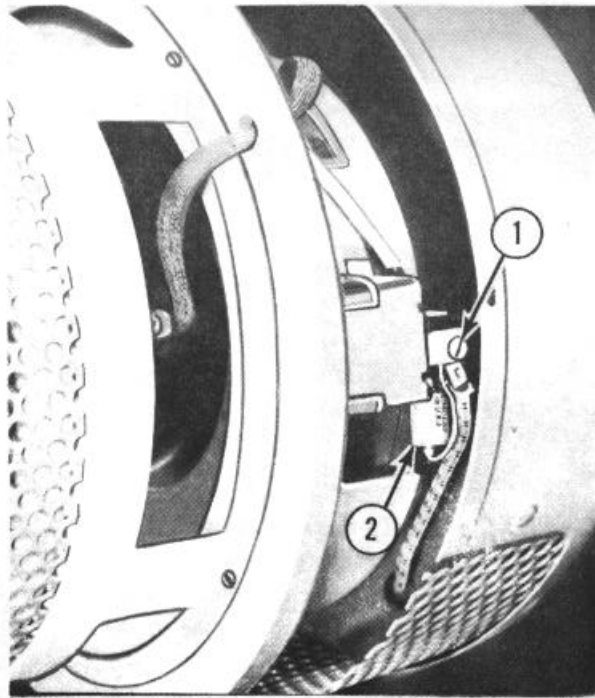

C

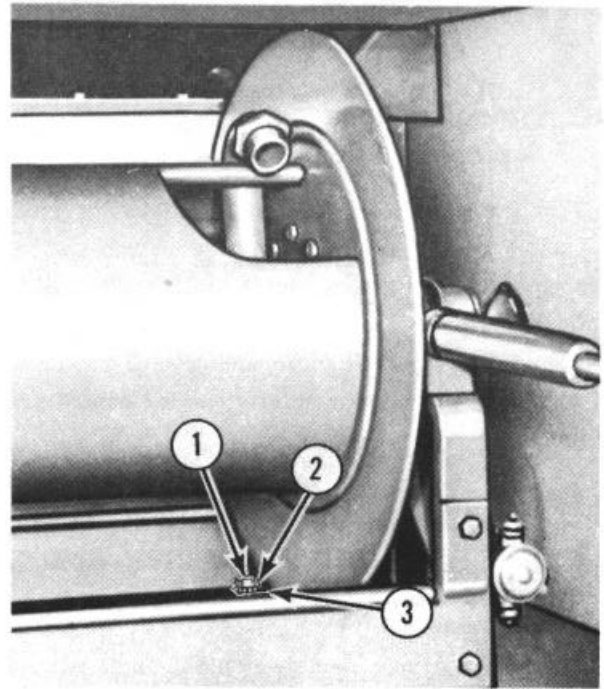

D

MSC 4210-205-12/21 ①

Figure 21. Radio interference suppression components.

- 1 Screw, machine, 10-32 x 1/4 in.
- 2 Washer, lock, ET, 1/4 in.
- 3 Screw, machine, 10 32 x 1/4 in.
- 4 Washer, lock, ET, 1/4 in.
- 5 Capacitor, 1.0-50v
- A Turn signal flasher capacitor

- 1 Screw, machine, 8-32 x 1/4 in. (2 rqr)
- 2 Capacitor, 25 mfd-100 vdc-20 amp
- B-Beacon warning light capacitor
- 1 Screw, machine, 8-32 x 1/4 in. (2 rqr)
- 2 Capacitor, 0.1-100 dc
- C-Siren-light flasher capacitor

- 1 Screw, cap, 3/8-16 x 1 in.
- 2 Washer, lock, ET, 3/8 in.
- 3 Ground strap (2 rqr)
- 4 Nut, 3/8-16
- D-Hose reel to hose reel motor ground strap

Figure 21-Continued.

that are identical. Capacitors must be the same size and have the same rating as the parts being replaced. It is essential that a good-metal-to-metal contact is achieved to maintain proper radio interference suppression. To correct faulty suppression, substitute new interference suppression components until the faulty components are discovered. Remove the capacitors and ground straps in the numerical sequence as illustrated on figure 21.

b. Secondary Suppression Component. Remove tooth-type lockwashers. If proper suppression is to be obtained, it is necessary that good metal-to-metal contact is made by tightening the mounting hardware employing tooth-type lockwashers.

54. Testing of Radio Interference Suppression Components

Test the capacitors for leaks and shorts on a capacitor tester; replace defective capacitors. If test equipment is not available and interference is indicated, isolate the cause of interference by the trial-and-error method of replacing each capacitor in turn until the cause of interference is located and eliminated.

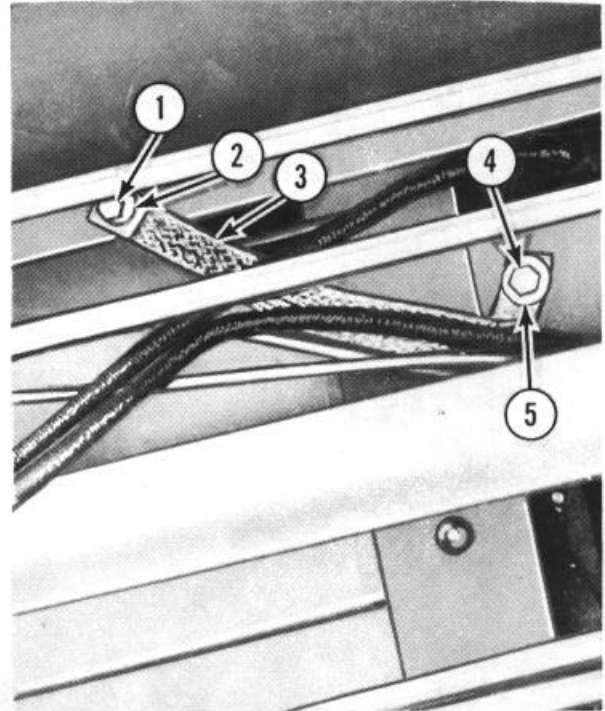

E

MSC 4210-205-12/21 ②

- 1 Screw, cap, 7 7/16-20 x 1 in.
- 2 Washer, flat, 7/16 in.
- 3 Ground strap (2 rqr)
- 4 Screw, cap, 7/16-20 x 1 in.
- 5 Washer, flat 7/16 in.

E - Pump compartment to chassis frame ground strap

Figure 21--Continued.

Section VII. RETAINERS, STEPS, TOOL BOX DOOR, GUARDS, HOSE BED ASSEMBLIES, AND LADDER SUPPORT ASSEMBLIES

55. General

The hose retainer mounted on the right rear of the fire truck provides a means of locking the hoses, inside the hose compartment. A retainer and bracket provides a means for mounting two foam applicator tubes. Two shovel buckets are located on the left rear of the fire truck. The ladder brackets are mounted on the top front of the left side compartments. Two fire extinguishers

brackets are mounted on the rear step. Folding steps are mounted at the front of the hose reel compartments and at the rear of the fire truck. A handrail is mounted on the rear of the fire truck and splash guards are mounted on each side of the fire truck below the instrument panels. The tool box door is mounted to the rear step between the fire extinguisher brackets. The hose bed partition is located on top of the fire truck water tank and divides the hose compartment into

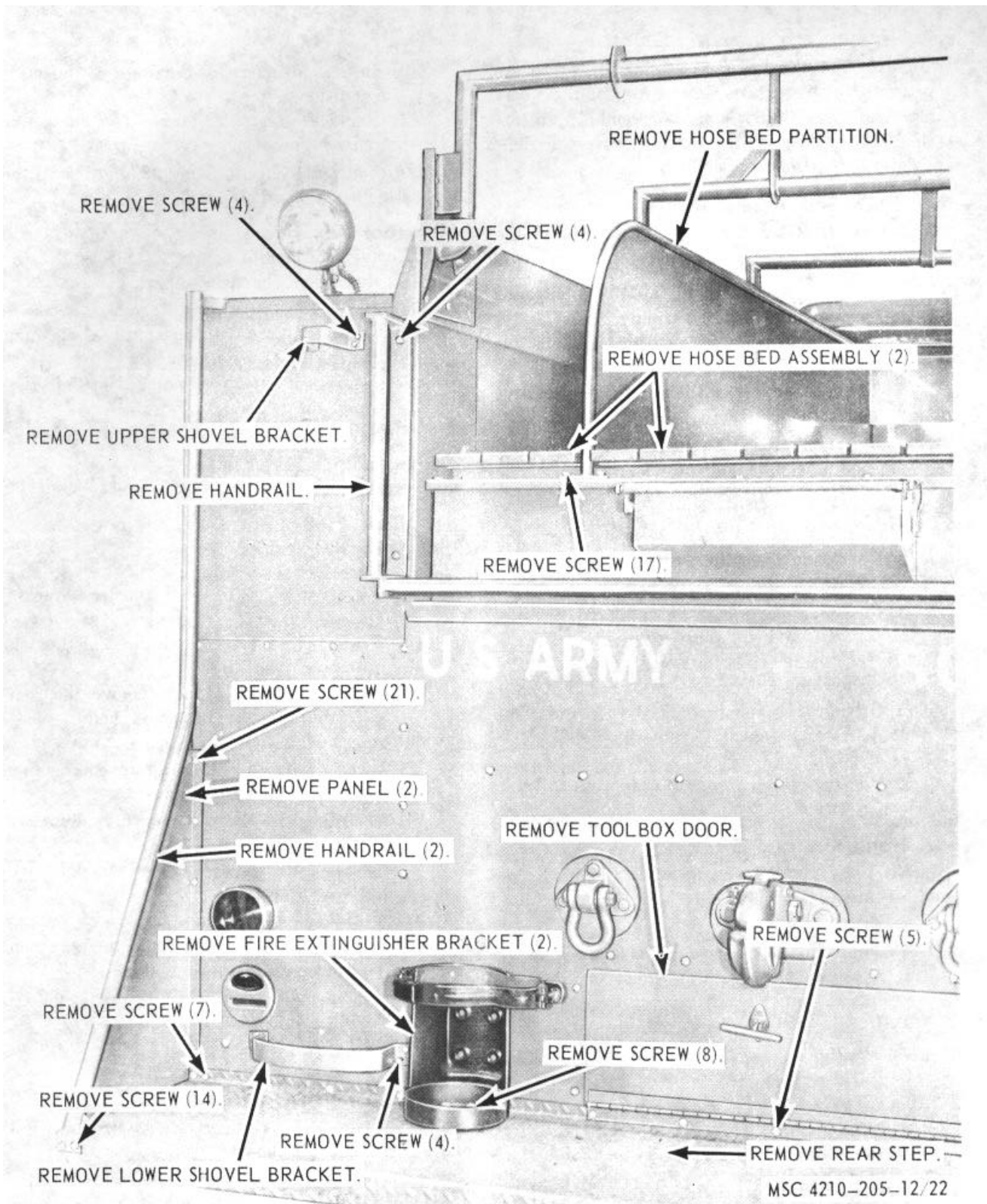

Figure 22. Hose bed assemblies, handrails, rear step, tool box door, and brackets, removal and installation.

TAGO 6839A

two parts. The two hose bed assemblies, which are constructed of wood slats, lay on top of the water tank. The three ladder support assemblies are attached to the sides of and extend above the right and left compartment assemblies.

56. Hose Bed Assemblies

a. Removal. Refer to figure 22, and remove the hose bed assemblies from the water tank.

b. Cleaning, Inspection, and Repair.

- (1) Clean all parts in an approved cleaning solvent, and dry thoroughly.
- (2) Inspect all parts for damaged or defective condition.
- (3) Replace or repair damaged or defective parts as necessary.

c. Installation. Refer to figure 22, and install the hose bed assemblies on the water tank.

57. Hose Bed Partition

a. Removal. Refer to figure 22, and remove the hose bed partition from the water tank.

b. Cleaning, Inspection, and Repair.

- (1) Clean all parts with an approved cleaning solvent, and dry thoroughly.
- (2) Inspect all parts for damaged or defective condition.
- (3) Replace or repair damaged or defective parts as necessary.

c. Installation. Refer to figure 22, and install the hose bed partition on the water tank.

58. Handrails and Brackets

a. Removal. Refer to figure 22, and remove the handrails and brackets from the special purpose body.

b. Cleaning, Inspection, and Repair.

- (1) Clean all parts with an approved cleaning solvent, and dry thoroughly.
- (2) Inspect all parts for damaged or defective condition.
- (3) Replace or repair damaged or defective parts as necessary.

c. Installation. Refer to figure 22, and install the handrails and brackets on the special purpose body.

59. Fire Extinguisher Bracket

a. Removal. Refer to figure 22, and remove the fire extinguisher bracket from the rear step.

b. Cleaning, Inspection, and Repair.

- (1) Clean all parts with an approved cleaning solvent, and dry thoroughly.
- (2) Inspect all parts for damaged or defective condition.

- (3) Replace or repair damaged or defective parts as necessary.

c. Installation. Refer to figure 22, and install the fire extinguisher bracket on the rear step.

60. Tool Box Door

a. Removal. Refer to figure 22, and remove the tool box door from the rear step.

b. Cleaning, Inspection, and Repair.

- (1) Clean all parts with an approved cleaning solvent, and dry thoroughly.
- (2) Inspect all parts for damaged or defective condition.
- (3) Replace or repair damaged or defective parts as necessary.

c. Installation. Refer to figure 22, and install the tool box door on the rear step.

61. Rear Step

a. Removal.

- (1) Remove the fire extinguisher bracket (para. 59).
- (2) Remove the side handrails and panels (para. 58).
- (3) Refer to figure 22, and remove the rear step from the special purpose body.

b. Cleaning, Inspection, and Repair.

- (1) Clean all parts with an approved cleaning solvent, and dry thoroughly.
- (2) Inspect all parts for damaged or defective condition.
- (3) Replace or repair damaged or defective parts as necessary.

c. Installation.

- (1) Refer to figure 22, and install the rear step on the special purpose body.
- (2) Install the side handrails and panels (para. 58).
- (3) Install the fire extinguisher bracket (para. 59)

62. Shovel Brackets

a. Removal. Refer to figure 22, and remove the shovel brackets from the apron.

b. Cleaning, Inspection, and Repair.

- (1) Clean all parts with an approved cleaning solvent, and dry thoroughly.
- (2) Inspect all parts for damaged or defective condition.
- (3) Replace or repair damaged or defective parts as necessary.

c. *Installation.* Refer to figure 22, and install the shovel brackets on the apron.

63. Ladder Support Assemblies

a. *Removal.* Refer to figure 23, and remove the ladder support assemblies from the special purpose body.

b. *Cleaning, Inspection, and Repair.*

- (1) Clean all parts with an approved cleaning solvent, and dry thoroughly.
- (2) Inspect all parts for damaged or defective condition.
- (3) Replace or repair damaged or defective parts as necessary.

c. *Installation.* Refer to figure 23, and install the ladder support assemblies on the special purpose body.

64. Foam Nozzle Retainer

a. *Removal.* Refer to figure 23, and remove the foam nozzle retainer from the apron.

b. *Cleaning, Inspection, and Repair.*

- (1) Clean all parts with an approved cleaning solvent, and dry thoroughly.
- (2) Inspect all parts for damaged or defective condition.
- (3) Replace or repair damaged or defective parts as necessary.

c. *Installation.* Refer to figure 23, and install the foam nozzle retainer on the apron.

65. Hose Retainer

a. *Removal.* Refer to figure 23, and remove the hose retainer from the apron.

b. *Cleaning, Inspection, and Repair.*

- (1) Clean all parts with an approved cleaning solvent, and dry thoroughly.
- (2) Inspect all parts for damaged or defective condition.

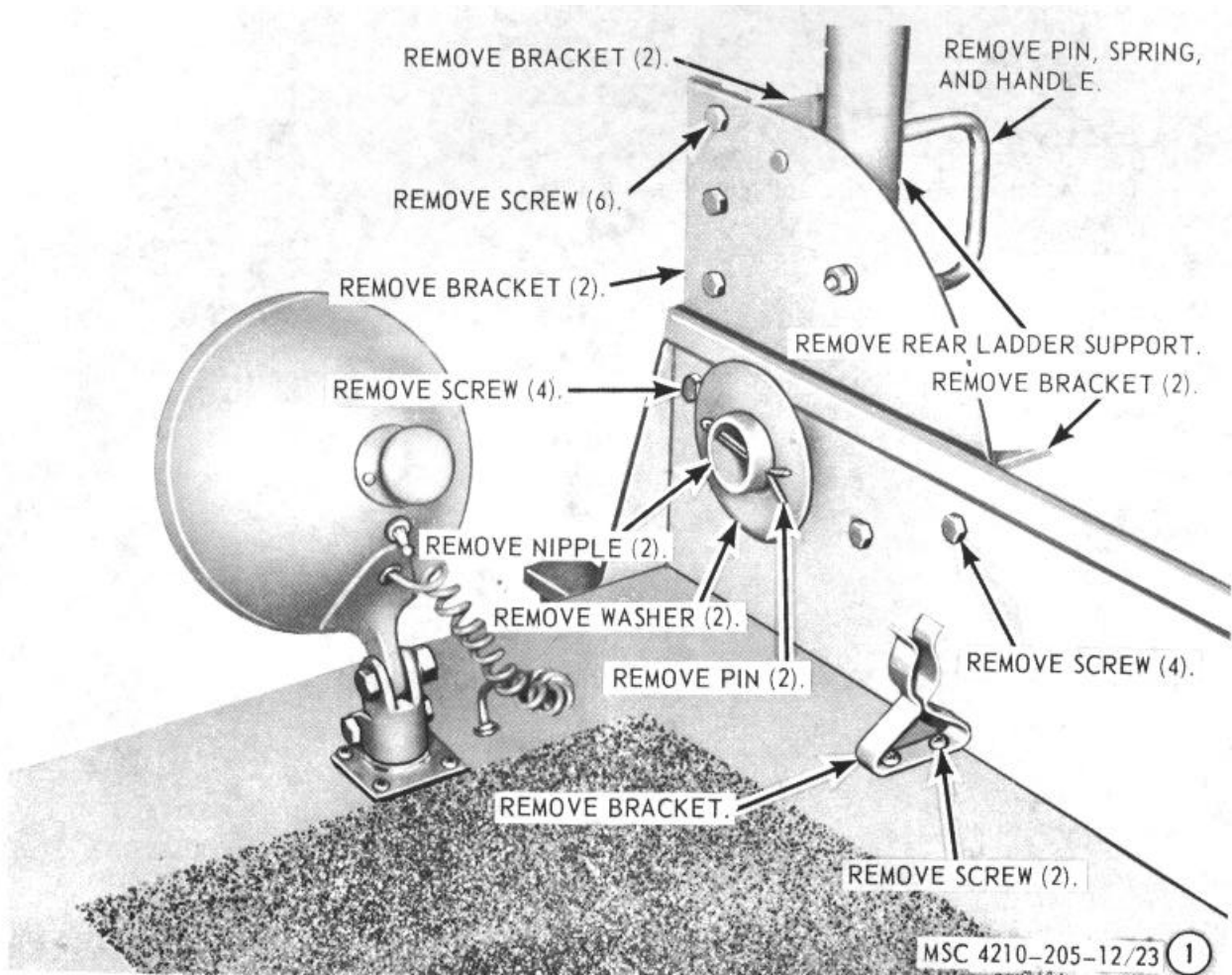

Figure 23. Ladder support assemblies, retainers and fill door, removal and installation.

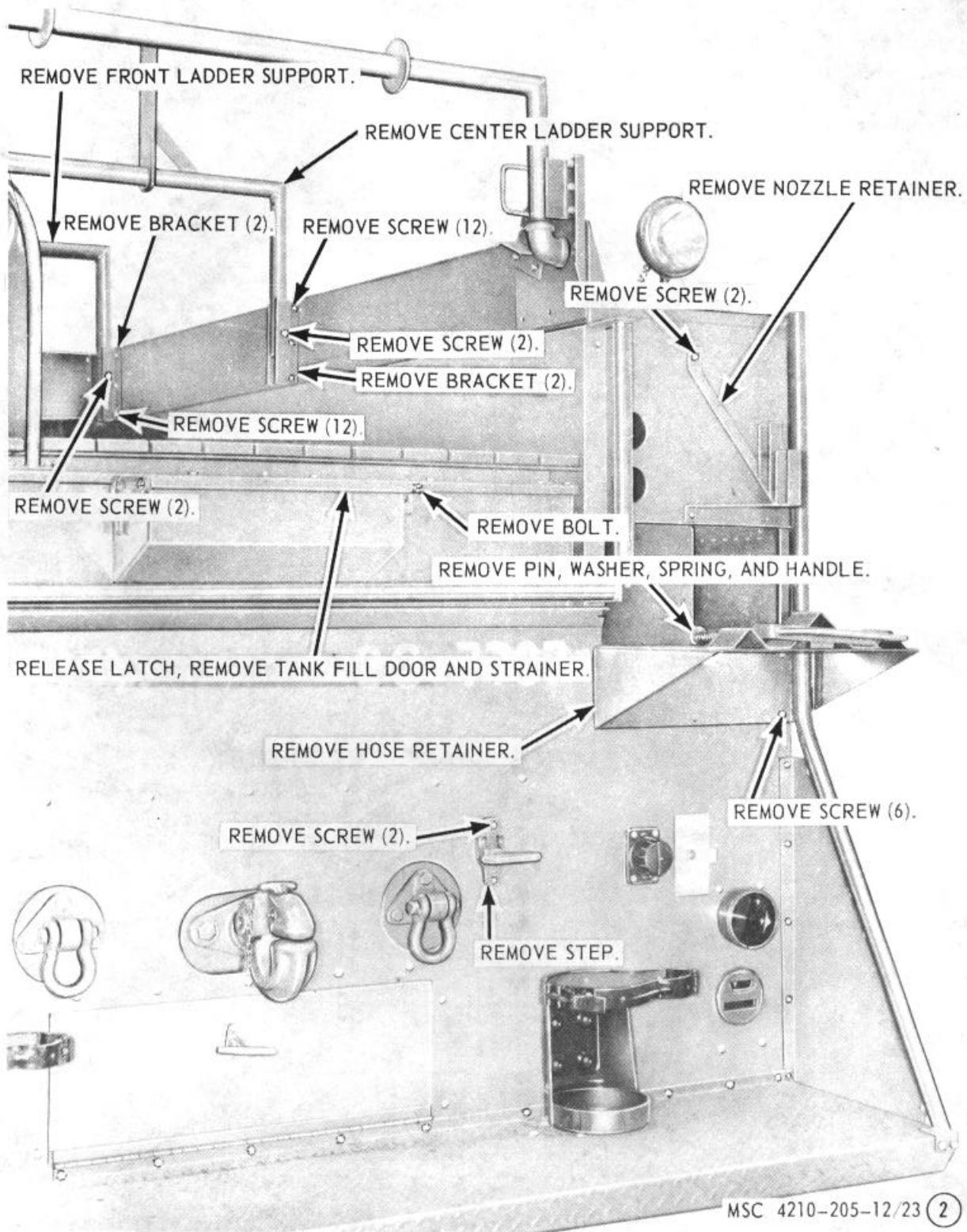

Figure 22-Continued.

- (3) Replace or repair damaged or defective parts as necessary.

c. *Installation.* Refer to figure 23, and install the hose retainer on the apron.

66. Folding Steps

a. *Removal.* Refer to figure 23, and remove the folding steps from the special purpose body.

NOTE

Remove folding steps from pump and hose reel compartment in a similar manner.

b. *Cleaning, Inspection, and Repair.*

- (1) Clean all parts with an approved cleaning solvent, and dry thoroughly.
- (2) Inspect all parts for damaged or defective condition.

- (3) Replace or repair damaged or defective parts as necessary.

c. *Installation.* Refer to figure 23, and install the folding steps on the special purpose body.

67. Splash Guards

a. *Removal.* Refer to figure 24, and remove the splash guard from the truck chassis.

b. *Cleaning, Inspection, and Repair.*

- (1) Clean all parts with an approved cleaning solvent, and dry thoroughly.
- (2) Inspect all parts for damaged or defective condition.
- (3) Replace or repair damaged or defective parts as necessary.

c. *Installation.* Refer to figure 24, and install the splash guards on the truck chassis.

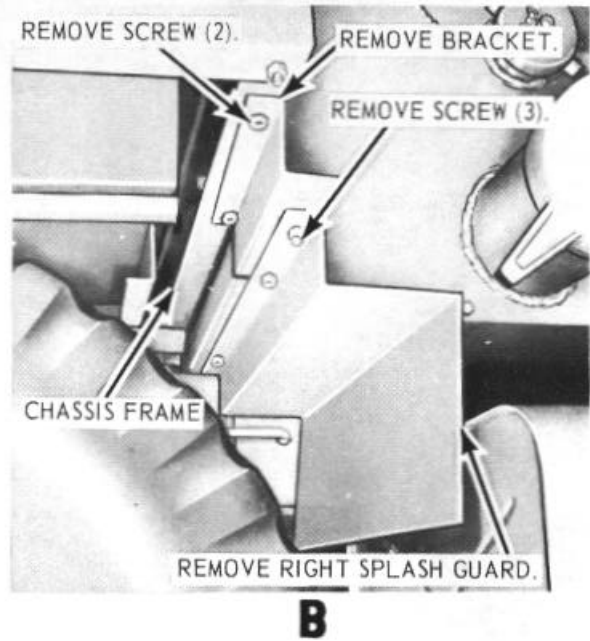
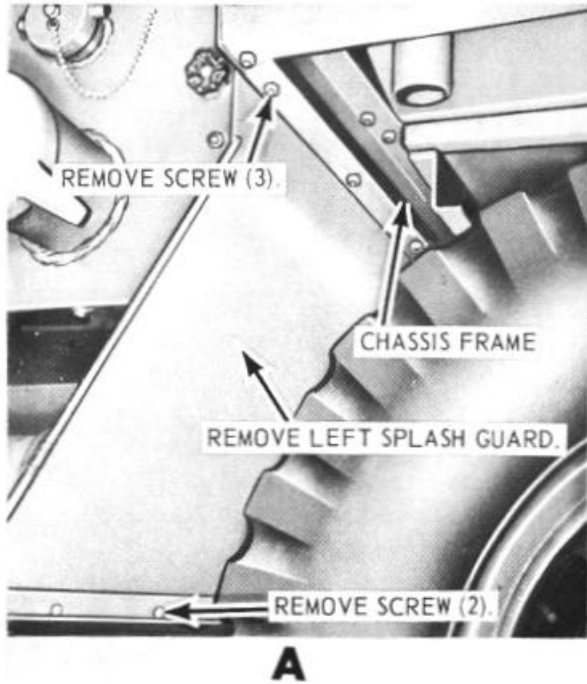

MSC 4210-205-12/24

A-Right splash guard B-Left splash guard
Figure 24. Splash guards, removal and installation.

Section VIII. COMPARTMENT ACCESSORY DOORS, BATTERY BOX, AND OIL PAN HEATER ADAPTER

68. General

The compartment accessories are brackets and mounting devices used to secure the fire fighting equipment and accessories such as first aid kits, hose nozzles, axes and fire extinguishers in the designed compartments along the right and left side of the fire truck. Each compartment is provided with a hinged door. The battery box is located on the right front cab step and houses two 12-volt batteries. The oil pan heater adapter is mounted under the oil pan.

69. Axe, Bars, Cutter, Compartment Accessories Brackets

a. *Removal.* Refer to figure 25, and remove the

axe, bars, cutters, and compartment accessories brackets from the compartment.

b. *Cleaning, Inspection, and Repair.*

- (1) Clean all parts with an approved cleaning solvent, and dry thoroughly.
- (2) Inspect all parts for damaged or defective condition.
- (3) Replace or repair damaged or defective parts as necessary.

c. *Installation.* Refer to figure 25, and install the axe, bars, and cutter accessories brackets on the compartment.

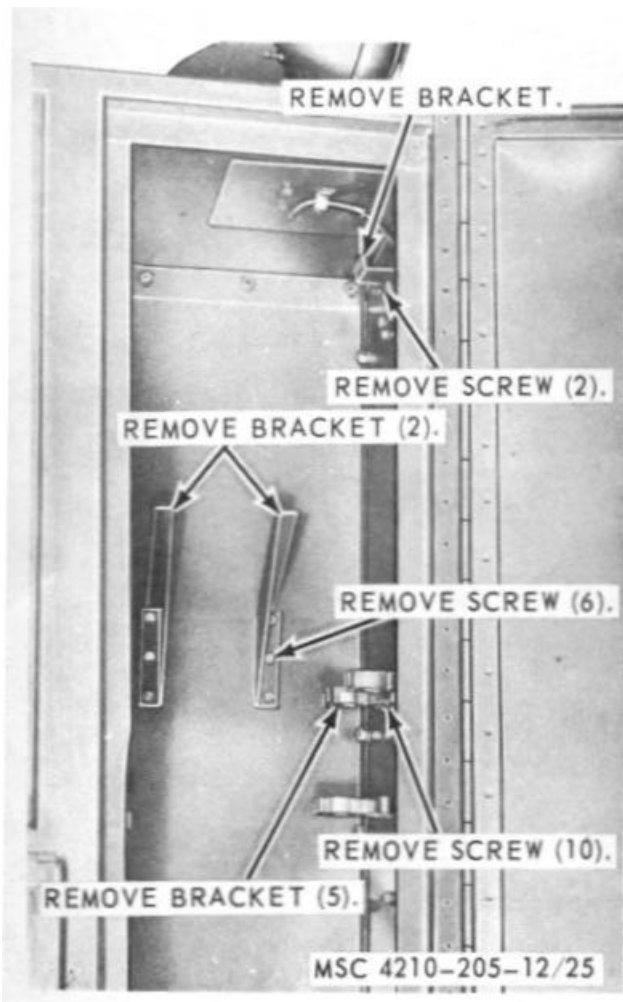

Figure 25. Axe, bars, cutter compartment accessory brackets, removal and installation.

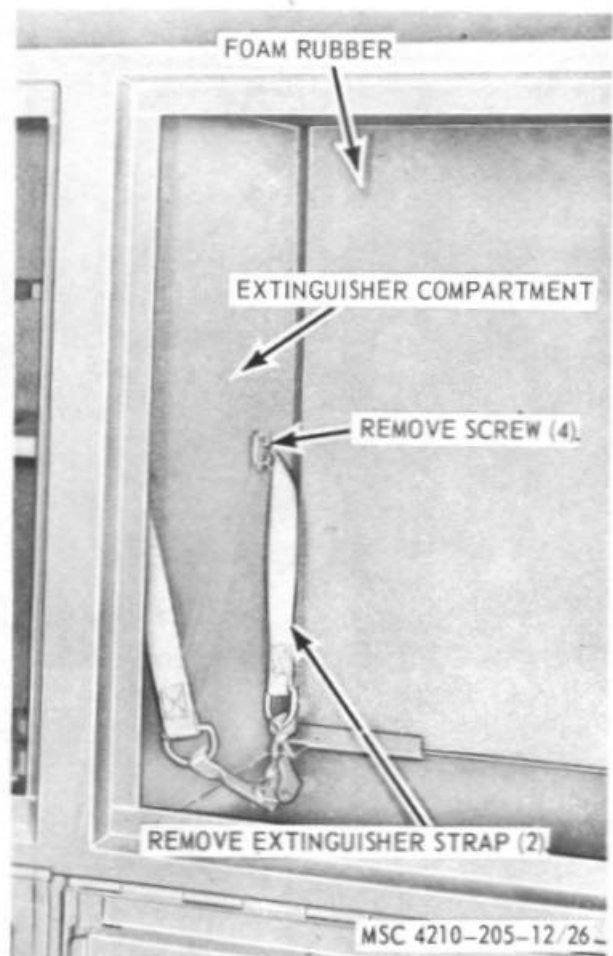

Figure 26. Extinguisher compartment accessories, removal and installation

TAGO 6839A

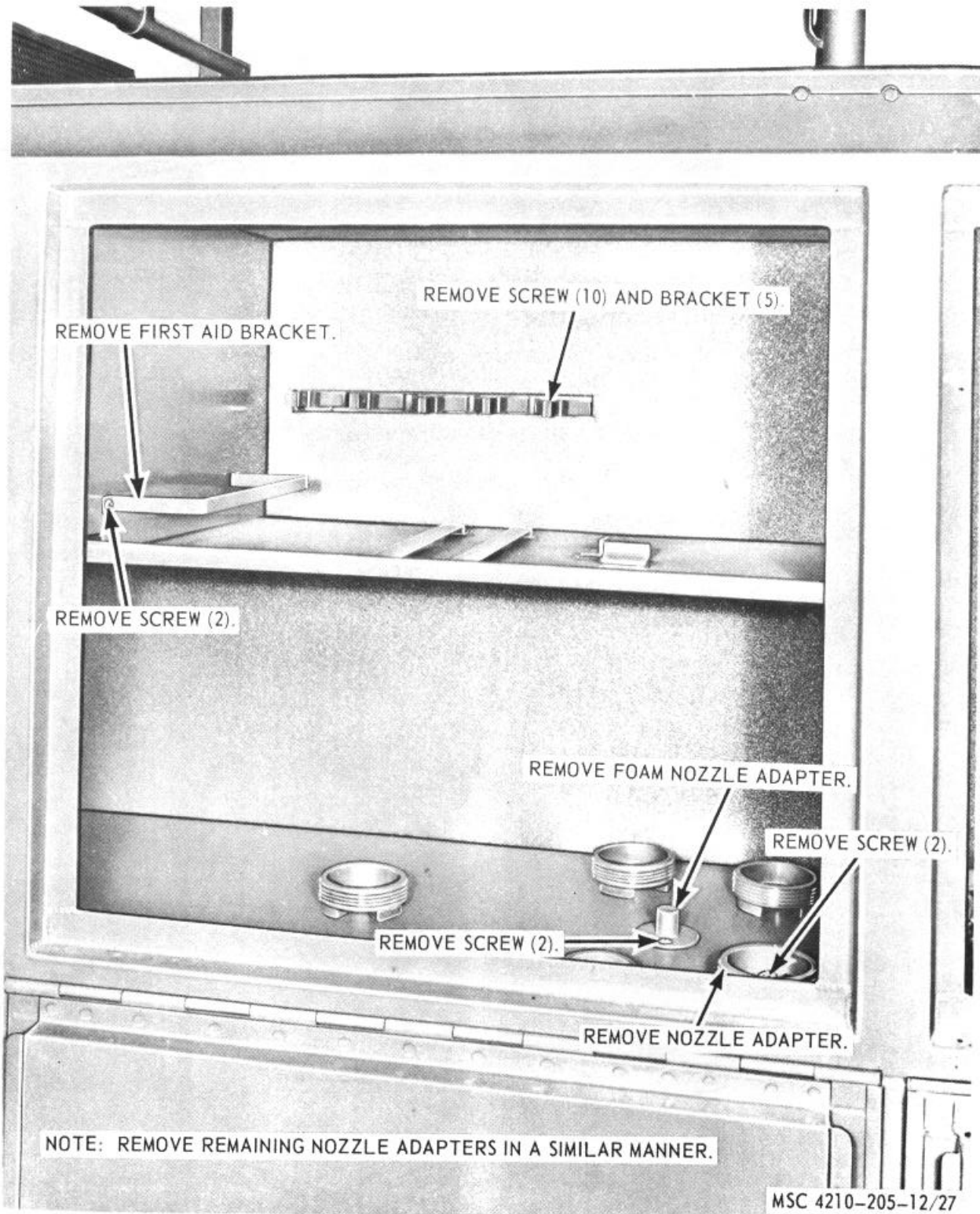

Figure 27. First aid bracket, hand lantern bracket, and fittings, removal and installation.

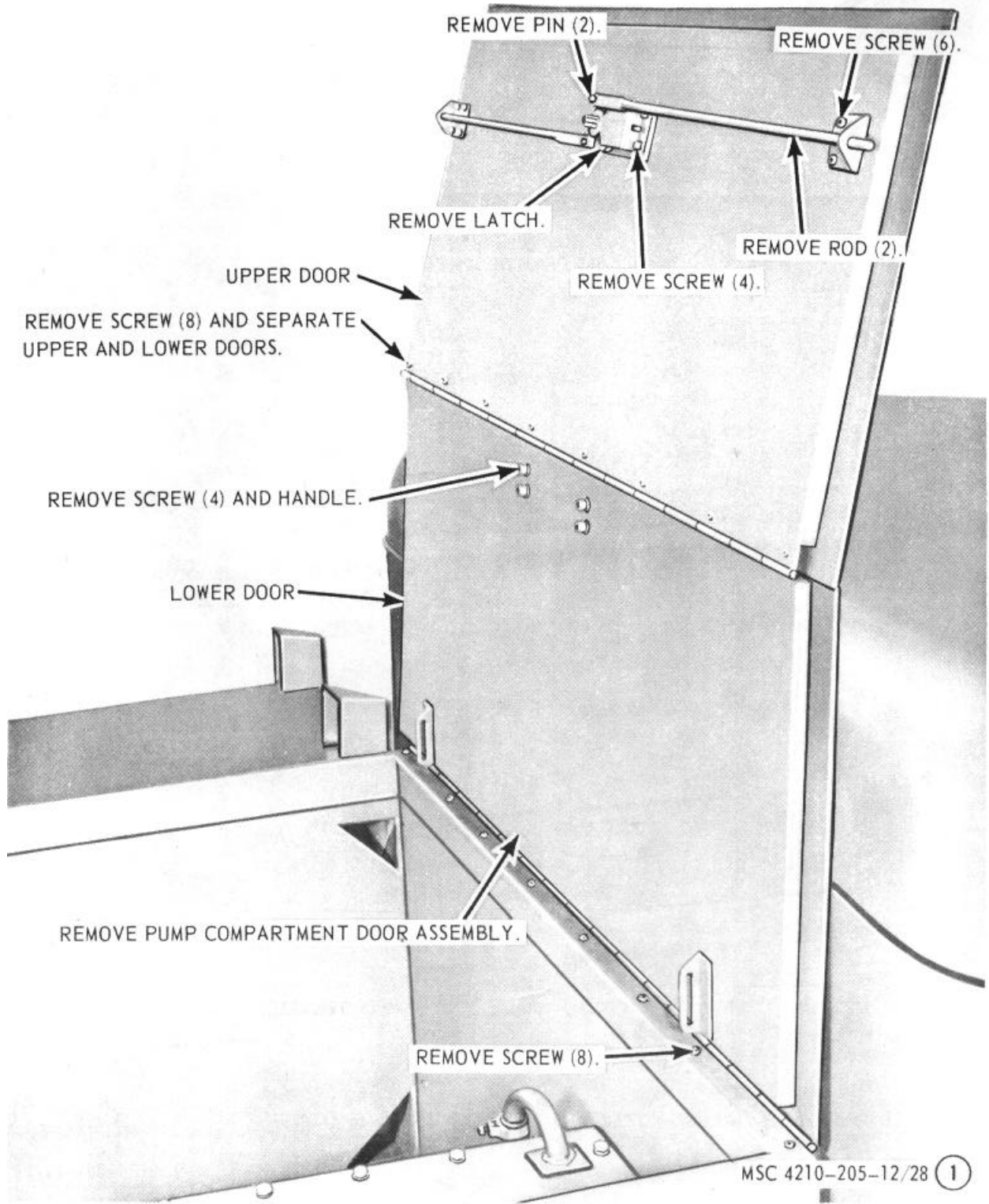

Figure 28. Pump and hose reel compartment door assemblies, removal and installation.

NOTE: REMOVE REMAINING COMPARTMENT DOORS, LATCHES, AND HANDLES IN A SIMILAR MANNER.

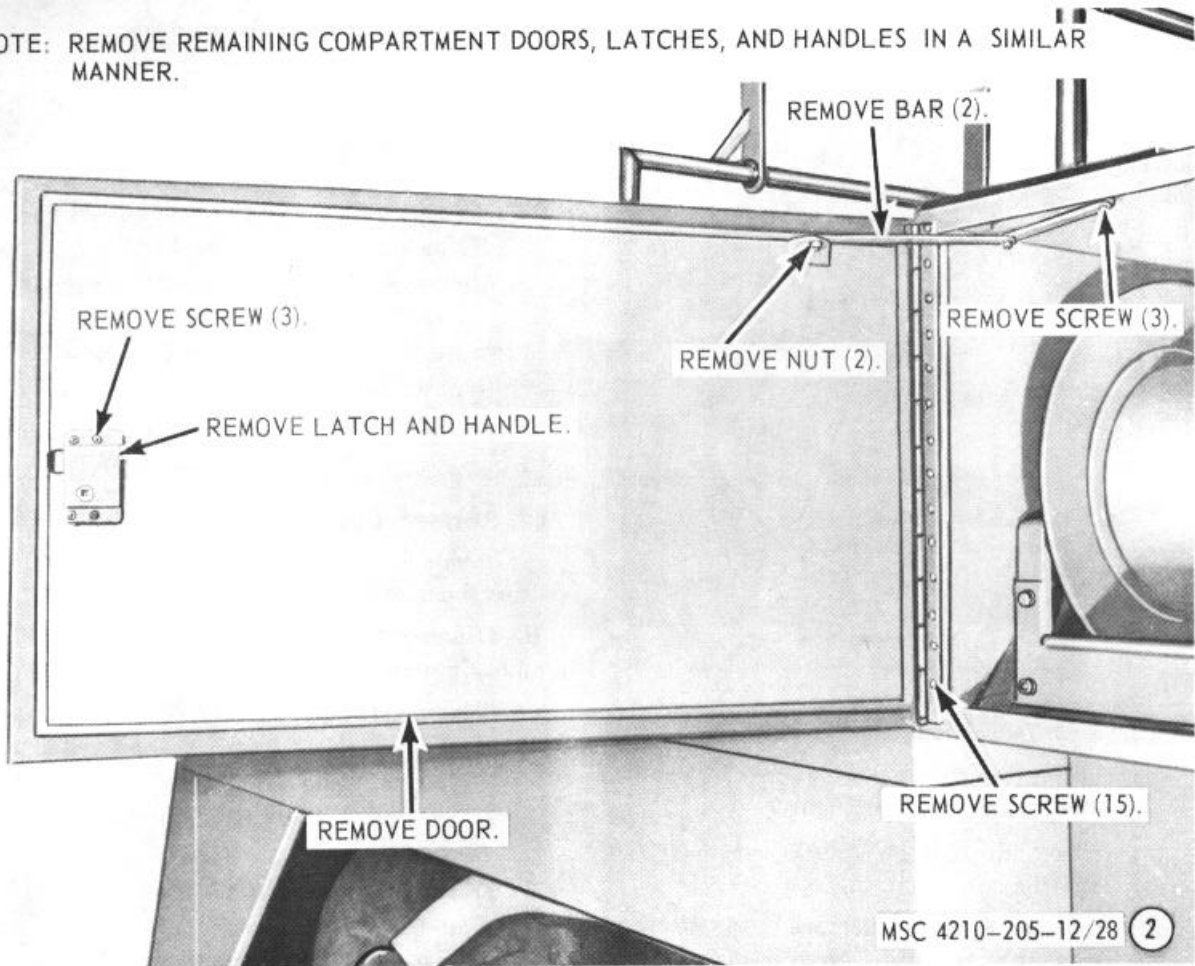

Figure 28 - Continued

70. Extinguisher Compartment Accessories

a. *Removal.* Refer to figure 26, and remove the extinguisher compartment accessories from the compartment.

b. *Cleaning, Inspection, and Repair.*

- (1) Clean all parts with an approved cleaning solvent, and dry thoroughly.
- (2) Inspect all parts for damaged or defective condition.
- (3) Replace or repair damaged or defective parts as necessary.

c. *Installation.* Refer to figure 26, and install the extinguisher compartment accessories on the compartment.

71. First Aid Bracket, Hand Lantern Bracket, and Fitting Compartment

a. *Removal.* Refer to figure 27, and remove

the first aid bracket, hand lantern bracket, and fittings from the compartment.

b. *Cleaning, Inspection, and Repair.*

- (1) Clean all parts with an approved cleaning solvent, and dry thoroughly.
- (2) Inspect all parts for damaged or defective condition.
- (3) Replace or repair damaged or defective parts as necessary.

c. *Installation.* Refer to figure 27, and install the first aid bracket, hand lantern bracket, and fittings from the compartment.

72. Pump and Hose Reel Compartment Door Assemblies

a. *Removal.* Refer to figure 28, and remove the doors from the compartment as necessary.



Figure 29. Oil pan heater adapter, removal and installation.

b. Cleaning, Inspection, and Repair.

- (1) Clean all parts with an approved cleaning solvent, and dry thoroughly.
- (2) Inspect all parts for damaged or defective condition.
- (3) Replace or repair damaged or defective parts as necessary.

c. Installation. Refer to figure 28, and install the pump and hose reel compartment door assemblies on the compartments as necessary.

73. Oil Pan Heater Adapter

a. Removal. Refer to figure 29, and remove the oil pan heater adapter from the engine oil pan.

b. Cleaning, Inspection, and Repair.

- (1) Clean all parts with an approved cleaning solvent, and dry thoroughly.
- (2) Inspect all parts for damaged or defective condition.
- (3) Replace or repair damaged or defective parts as necessary.

c. Installation. Refer to figure 29, and install the oil pan heater adapter on the engine oil pan.

74. Battery Box

a. Removal. Refer to figure 30, and remove the battery box from the truck chassis.

b. Disassembly. Refer to figure 31, and disassemble the battery box.

c. Cleaning, Inspection, and Repair.

- (1) Clean all parts with an approved cleaning solvent, and dry thoroughly.
- (2) Inspect all parts for damaged or defective condition.
- (3) Replace or repair damaged or defective parts.

d. Reassembly. Refer to figure 31, and reassemble the battery box in the reverse order.

e. Installation. Refer to figure 30, and install the battery box on the truck chassis.

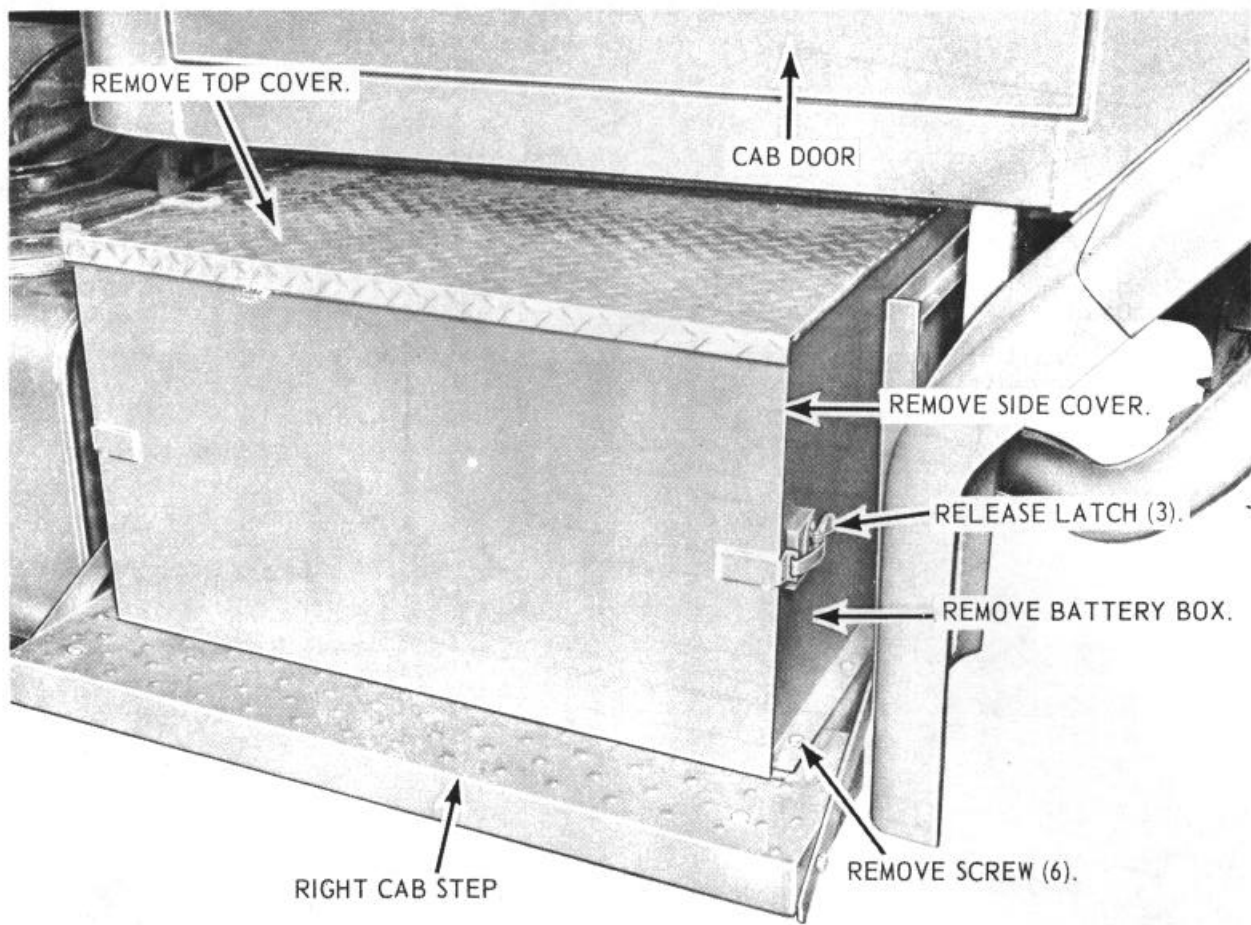

MSC 4210-205-12/30

Figure 30. Battery box, removal and installation.

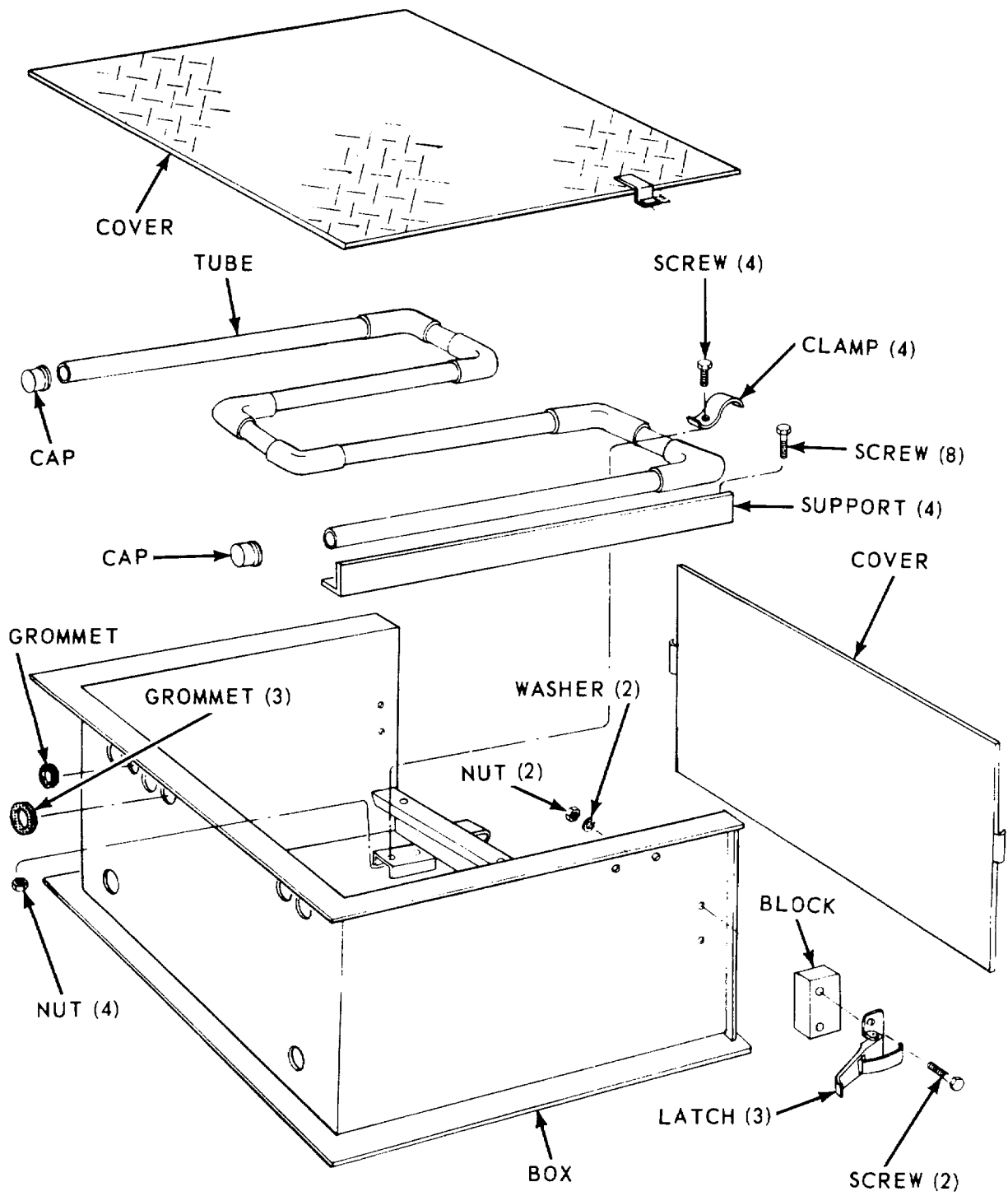

MSC 4210-205-12/31

Figure 31. Battery box, exploded view.

Section IX. FUEL SYSTEM

75. General

The fuel system consists of a manually operated throttle control that is located on the lower left side area

of the left pump operator's control panel. It provides means of changing engine speed other than by use of controls in the cab.

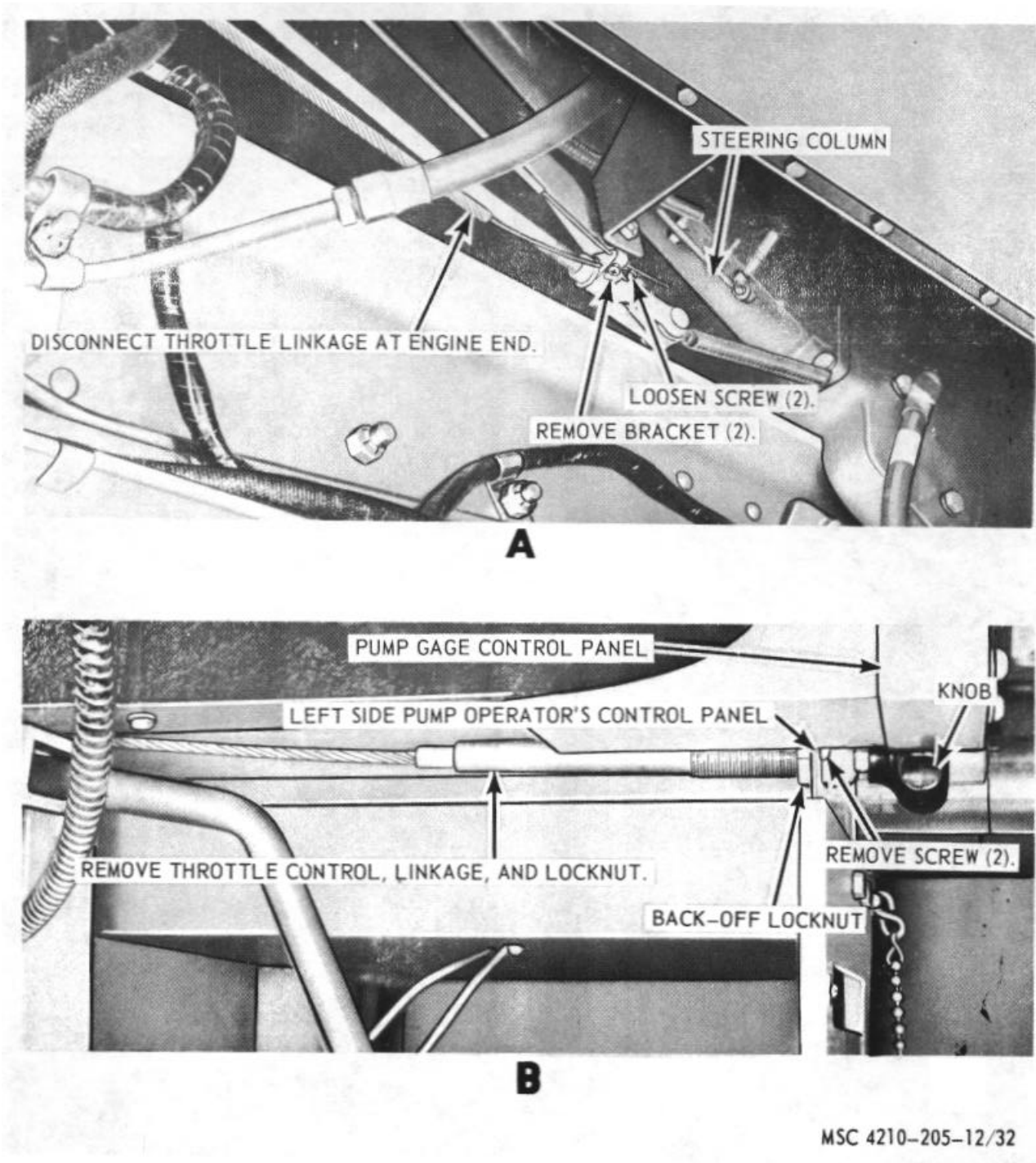

A-Engine disconnect points

B--Control panel disconnect points

Figure 32. Throttle control and linkage, removal and installation.

76. Throttle Control and Linkage

a. *Removal.* Refer to figure 32, and remove the throttle control and linkage from the engine and instrument panel.

b. *Cleaning, Inspection, and Repair.*

(1) Clean all parts with a clean cloth dampened in an approved cleaning solvent, and dry thoroughly.

(2) Inspect all parts for damaged or defective condition.

(3) Replace or repair damaged or defective parts as necessary.

c. *Installation.* Refer to figure 32, and install the throttle control and linkage on the engine and instrument panel.

Section X. AIR SYSTEM

77. General

This section consists of the various fittings and

tubing which connect the air brake system to the air tanks.

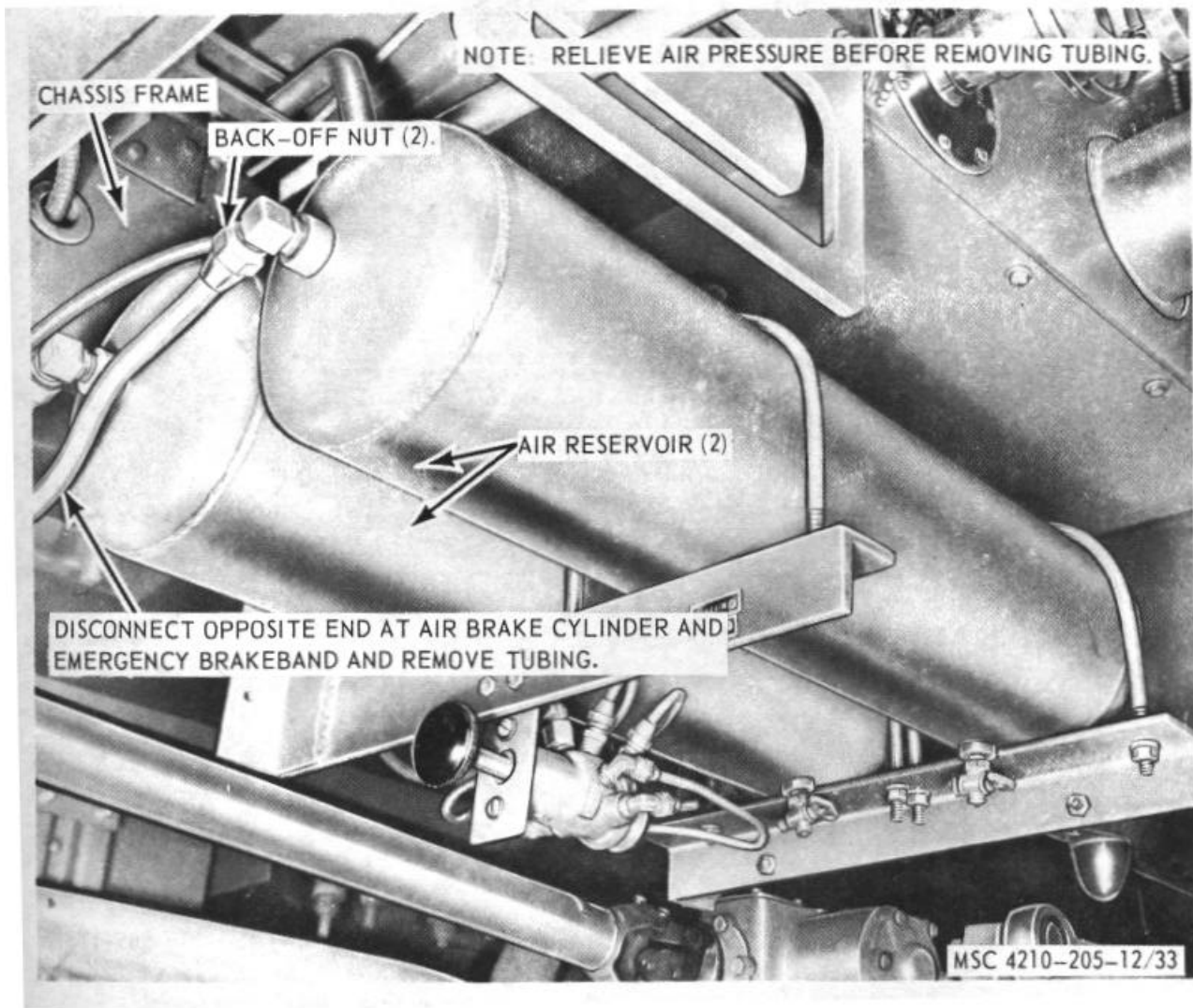

Figure 33. Air tank tubing and fittings, removal and installation.

78. Air Tank Tubing and Fittings

a. *Removal.* Refer to figure 33, and remove the air tank tubing and fittings from the unit.

b. *Cleaning, Inspection, and Repair.*

(1) Clean all parts with an approved cleaning solvent, and dry thoroughly.

(2) Inspect all parts for damaged or defective condition.

(3) Replace or repair damaged or defective parts as necessary.

c. *Installation.* Refer to figure 33, and install the air tank tubing and fittings on the unit.

Section XI. ELECTRICAL SYSTEM

79. General

The electrical system consists of two spotlights, one mounted on each of the windshield posts, two rear flood headlights mounted on the rear of the fire truck, two front and two directional lights and an electric siren mounted on the left front fender, rotating beacon warning light mounted on the top of the cab. These

lights have waterproof, seal-beam-type lamps. A flasher assembly mounted behind the cab instrument panel functions to interrupt the circuit to the directional light assemblies. A dome light mounted above the left side control panel furnishes illumination for pump operating controls. A temperature warning light, oil pressure warning light, and two panel lights are mounted in the instrument panel on the left side. Two underhood lights

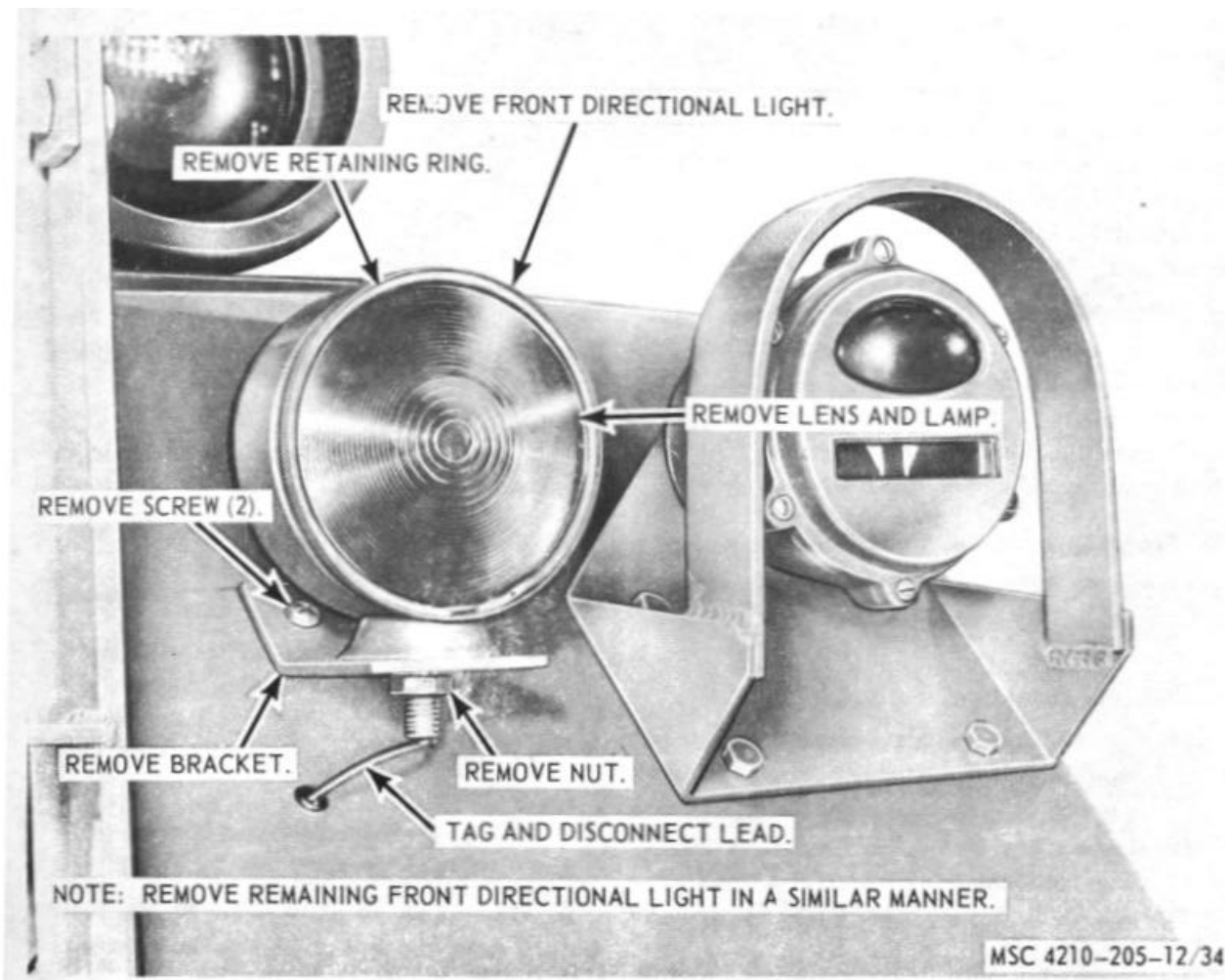

Figure 84. Front directional lights, removal and installation.

mounted on each side of the front of the radiator furnish illumination for the engine. Two motor solenoid relays and motors. one mounted on each hose reel assembly and one motor solenoid and motor mounted on the priming pump serve to furnish power for the priming pump and hose reels. There are two battery charging receptacles located at the rear of the unit above the apron. The temperature and oil pressure sending units are mounted on the engine. Refer to TM 9-2320-235-10 for the chassis and engine electrical components.

80. Wiring

a. *General.* When testing, repairing, or replacing the wiring, refer to wiring diagram (fig. 3).

b. *Testing.* Test a wire for continuity by disconnecting each end from the component or components to which it is connected. Touch the test probes of a multimeter to each end of the wire. If continuity is not indicated, the wire is defective and must be repaired or replaced.

c. *Repair.* Shave the insulation on the wire at both ends of the break and twist the bare wires together and solder the connection. Cover the repaired breaks with electrical tape and friction tape.

If a terminal breaks off a wire, replace it, using a like terminal.

d. *Replacement.* Replace a wire by disconnecting it from the component or components and remove the wire. Install a new wire and connect it. If a broken wire is part of a wiring harness, disconnect the wire and tape the ends. Install a new wire and attach it to the outside of the wiring harness.

81. Front Directional Light Assembly

a. *Removal.* Refer to figure 34, and remove the front directional light assembly from the fire truck fenders.

b. *Cleaning, Inspection, and Repair.*

- (1) Clean all parts with a clean cloth dampened in an approved cleaning solvent, and dry thoroughly.
- (2) Inspect lens, gasket for damaged or defective condition.
- (3) Inspect lamp for cracks, breaks, or burned out condition.
- (4) Replace or repair damage(d or defective parts as necessary.

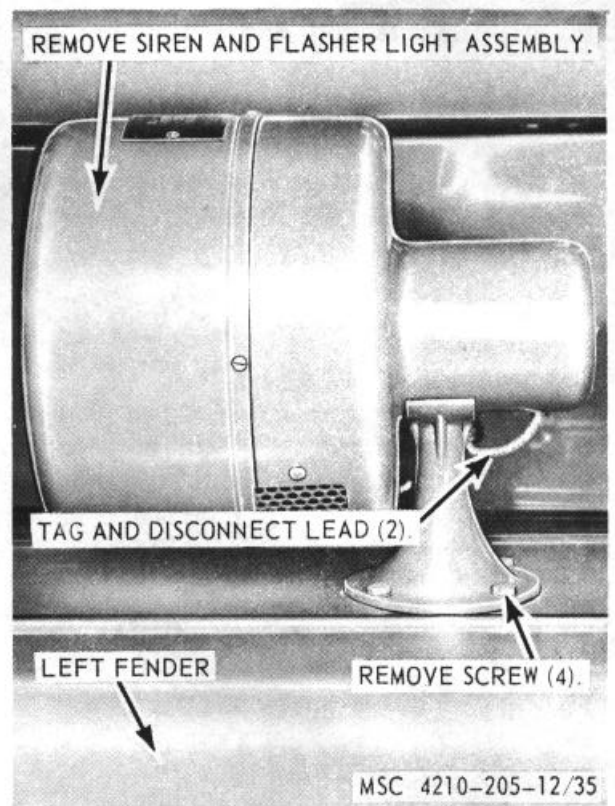

Figure 35. Siren and flasher light, removal and installation.

c. *Installation.* Refer to figure 34, and install the front directional lights on the fire truck fenders.

82. Siren and Flasher Light

a. *Removal.* Refer to figure 35, and remove the siren and flasher light from the fire truck fender.

b. *Disassembly.* Refer to figure 36. and disassemble the siren and flasher light.

c. *Cleaning, Inspection., and Repair.*

- (1) Clean all parts with a clean cloth dampened in an approved cleaning solvent, and dry thoroughly.
- (2) Inspect all parts for damaged or defective condition.
- (3) Replace or repair damaged or defective parts as necessary.

d. *Reassembly.* Refer to figure 36. and reassemble the siren and flasher light in the reverse order.

c. *Installation.* Refer to figure 3.5, an(i install the siren and flasher light on the fire truck fender.

TAGO 6839A

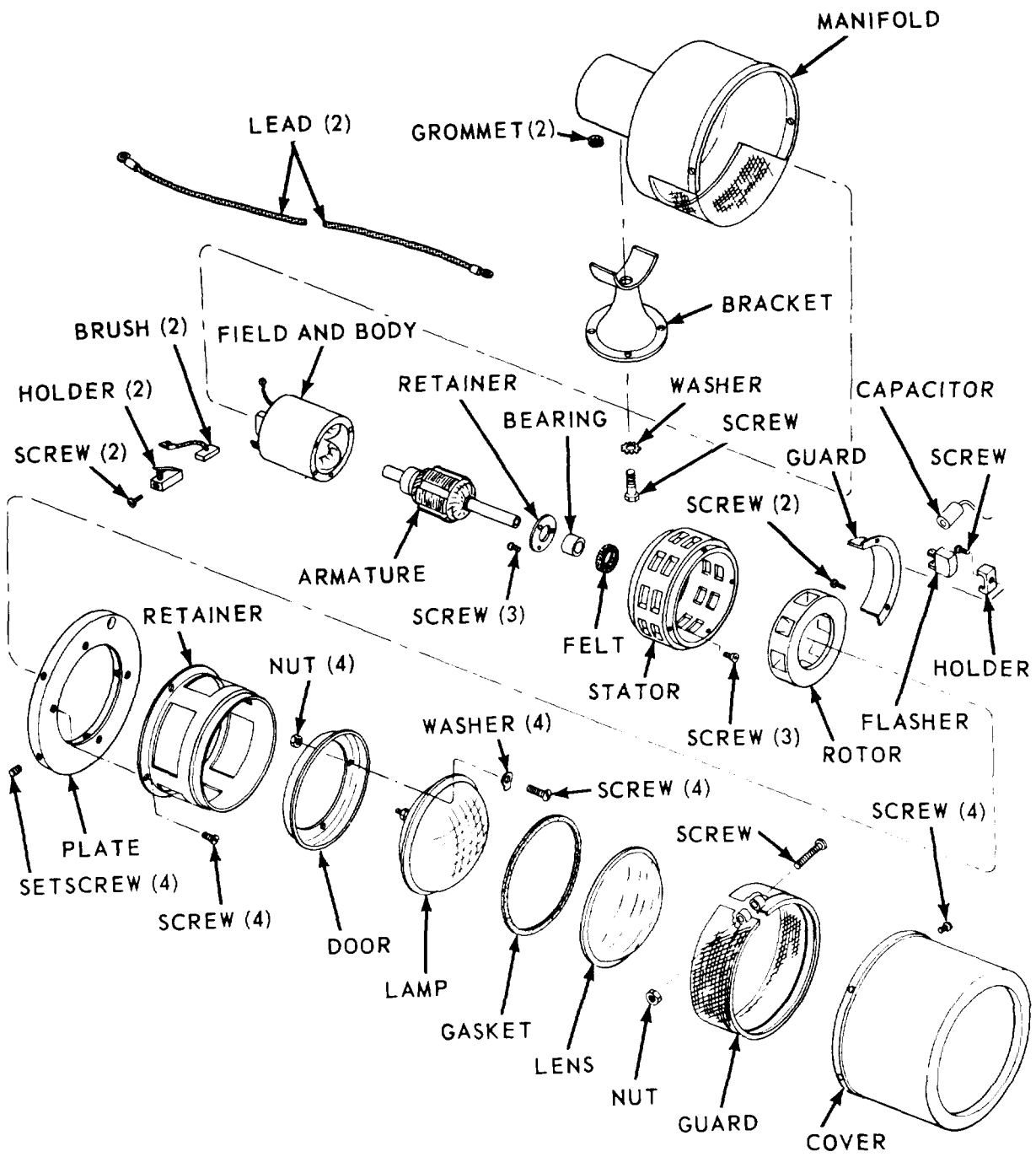

MSC 4210-205-12/36

Figure 36. Siren and flasher light, exploded view.

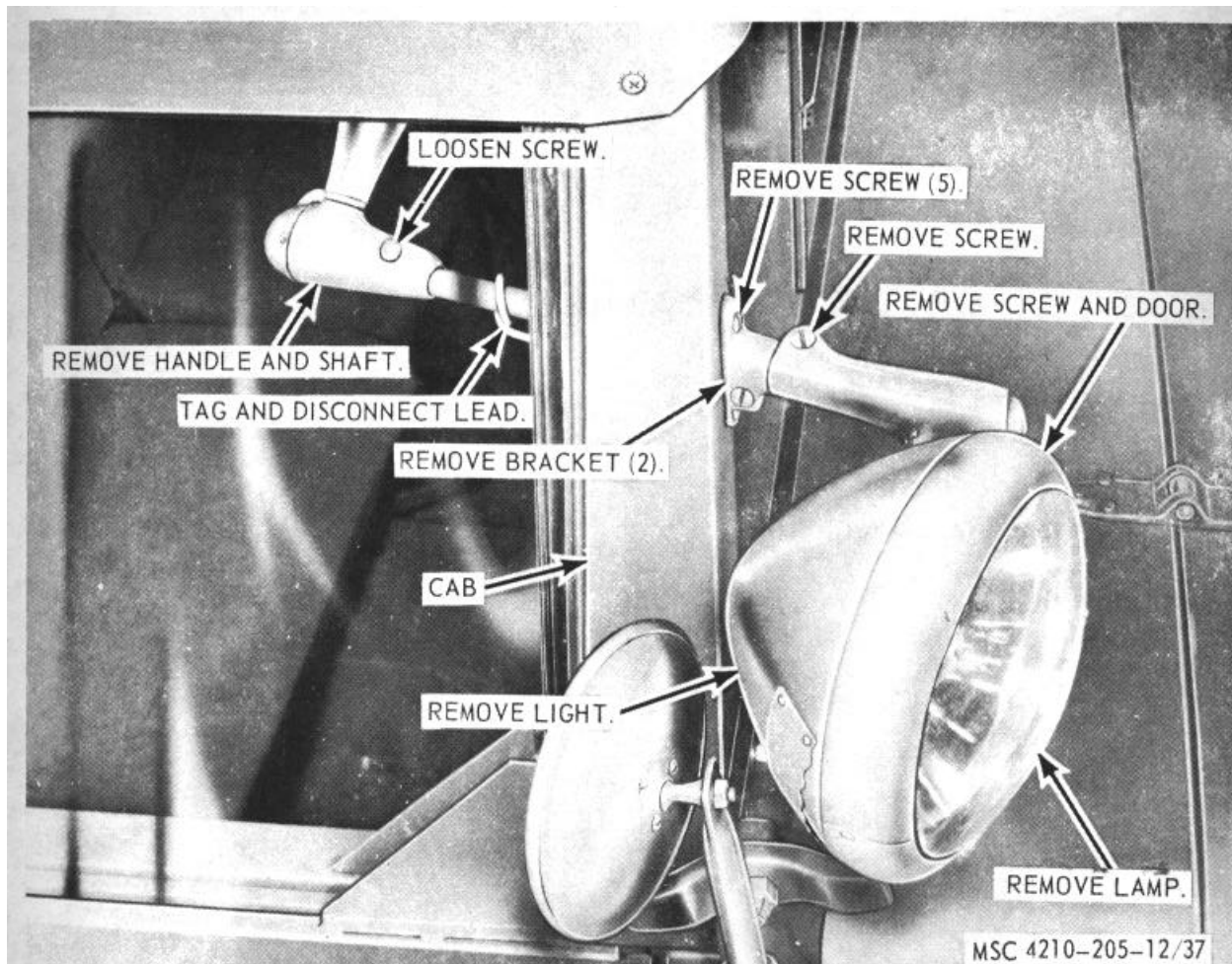

Figure 37. Spotlight, removal and installation.

83. Spotlight

- a. *Removal.* Refer to figure 37, and remove the spotlight from the fire truck cab.
- b. *Cleaning, Inspection, and Repair.*
 - (1) Clean all parts with a clean cloth dampened in an approved cleaning solvent, and dry thoroughly.
 - (2) Inspect door gasket and body for damaged or defective condition.
 - (3) Inspect lamp for cracks, breaks, or burned out condition.
 - (4) Replace or repair damaged or defective parts as necessary.
- c. *Installation.* Refer to figure 37, and install the spotlight on the fire truck cab.

84. Beacon Warning Light

- a. *Removal.* Refer to figure 38, and remove the beacon warning light from the fire truck.
- b. *Disassembly.* Refer to figure 39, and disassemble the beacon warning light.
- c. *Cleaning, Inspection, and Repair.*
 - (1) Clean all parts with a clean cloth dampened in an approved cleaning solvent, and dry thoroughly.
 - (2) Inspect all parts for damaged or defective condition.
 - (3) Replace or repair damaged or defective parts as necessary.
- d. *Reassembly.* Refer to figure 39, and reassemble the beacon warning light in the reverse order.

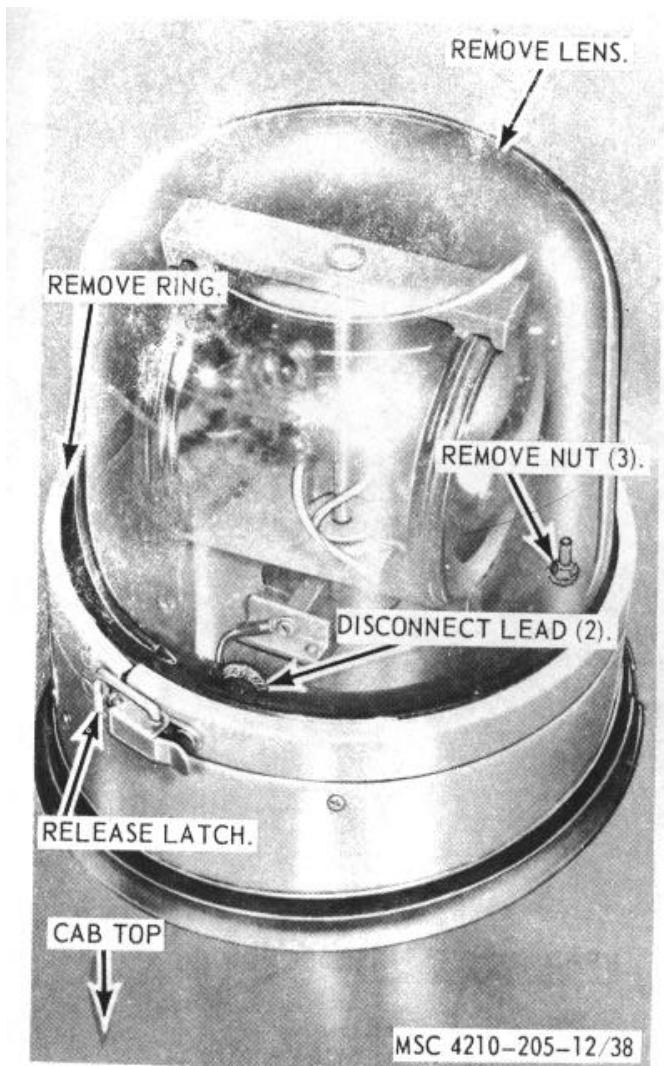

Figure 38. Beacon warning light, removal and installation.

e. *Installation.* Refer to figure 38, and install the beacon warning light on the fire truck cab.

85. Underhood Lights

a. *Removal.* Refer to figure 40, and remove the underhood lights from the fire truck radiator mounting bracket.

b. *Cleaning, Inspection, and Repair*

- (1) Clean all parts with a clean cloth dampened in an approved cleaning solvent and dry thoroughly.
- (2) Inspect body for damaged or defective condition.
- (3) Replace or repair damaged or defective parts as necessary.

- (4) Inspect lamps for cracks, breaks, or burned out condition.

c. *Installation.* Refer to figure 40, and install the underhood lights on the fire truck radiator mounting bracket.

86. Siren Solenoid Relay

a. *Removal.* Refer to figure 41, and remove the siren solenoid relay from the engine compartment.

b. *Cleaning, Inspection, and Repair.*

- (1) Clean all parts with a clean cloth dampened in an approved cleaning solvent, and dry thoroughly.
- (2) Inspect all parts for damaged or defective condition.
- (3) Replace or repair damage(or defective parts as necessary.

c. *Installation.* Refer to figure 41, and install the siren solenoid relay on the engine compartment.

87. Engine Oil Pressure Sending Unit

a. *Removal.* Refer to figure 42, and remove the engine oil pressure sending unit from the engine.

b. *Cleaning, Inspection, and Repair.*

- (1) Clean all parts with a clean cloth dampened in an approved cleaning solvent, and dry thoroughly.
- (2) Inspect all parts for damaged or defective condition.
- (3) Replace or repair damaged or defective l)arts as necessary.

c. *Installation.* Refer to figure 42, and install the engine oil pressure sending unit on the engine.

88. Engine Temperature Sending Unit

a. *Removal.* Refer to figure 43, and remove the engine temperature sending unit form the engine

b. *Cleaning, Inspection, and Repair.*

- (1) Clean all parts with a clean cloth dampened in a n approved cleaning solvent, and dry thoroughly.
- (2) Inspect all parts for damaged or defective condition.
- (3) Replace or repair damaged or defective parts as necessary.

c. *Installation.* Refer to figure 43, and install the engine temperature sending unit on the engine.

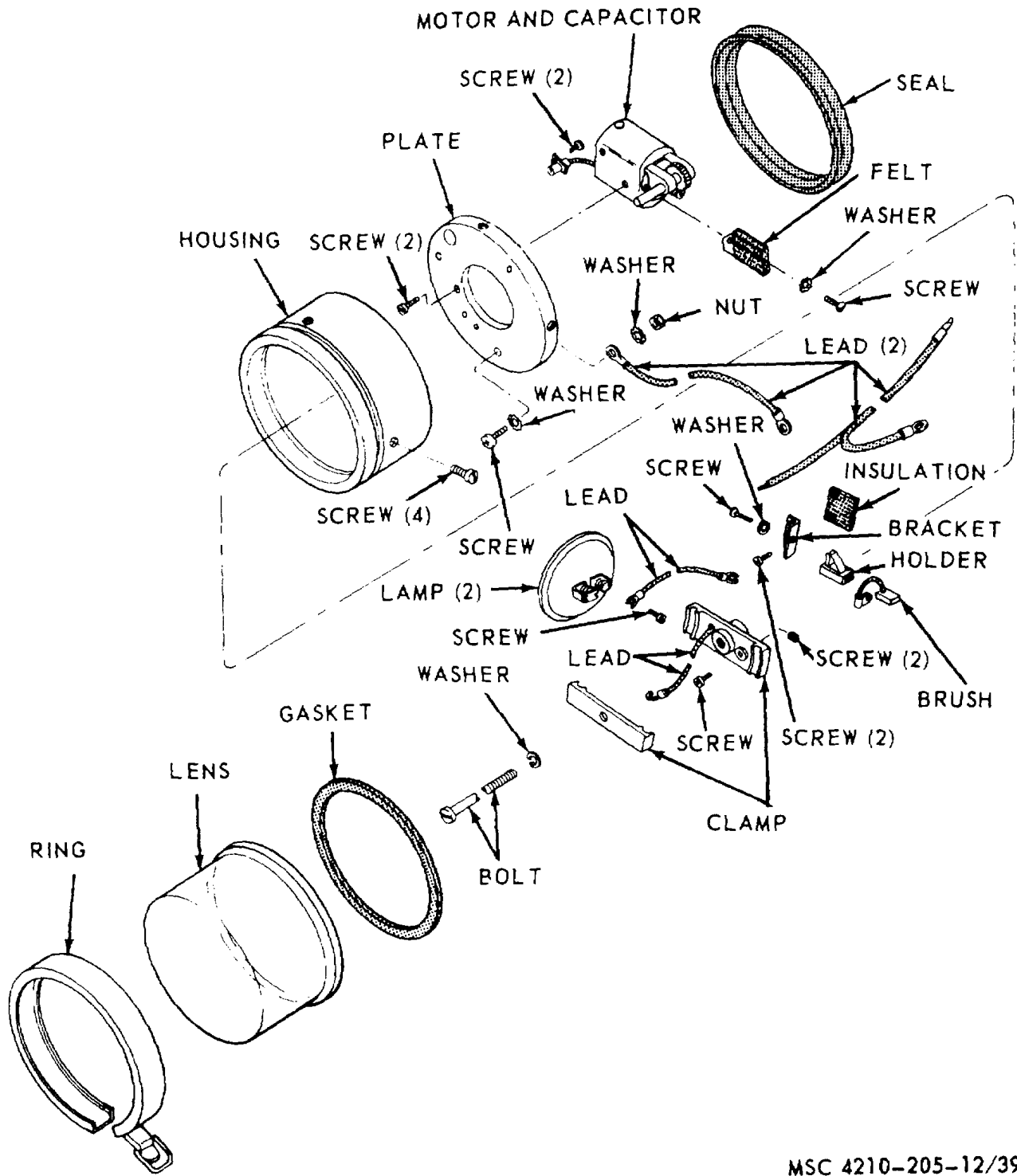

MSC 4210-205-12/39

Figure 39. Beacon warning light, exploded view.

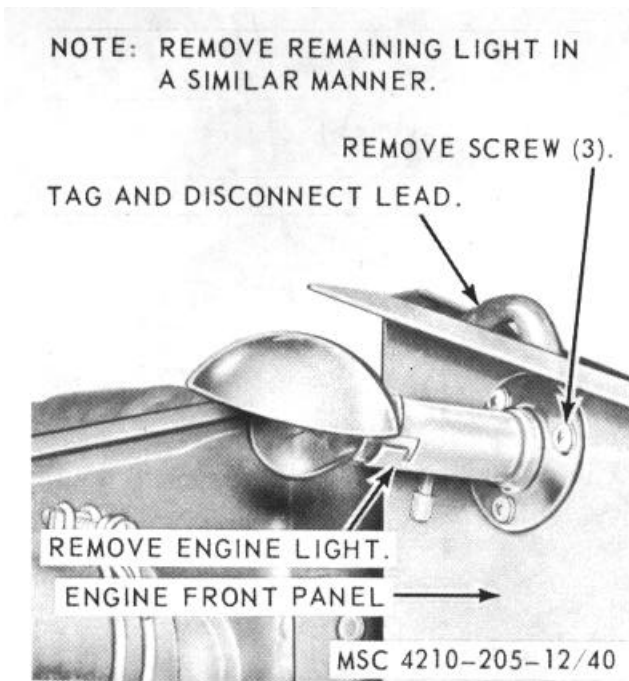

Figure 40. Underhood lights, removal and installation.

89. Flasher Assembly

- a. *Removal.* Refer to figure 44, and remove the flasher assembly from the fire truck control panel.
- b. *Cleaning, Inspection, and Repair.*
 - (1) Clean all parts with a clean cloth dampened in an approved cleaning solvent, and dry thoroughly.
 - (2) Inspect all parts for damaged or defective condition.
 - (3) Replace or repair damaged or defective parts as necessary.
- c. *Installation.* Refer to figure 44, and install the flasher assembly on the fire truck control panel.

90. Circuit Breakers

- a. *Removal.* Refer to figure 45, and remove the circuit breakers from the cab fire wall.
- b. *Cleaning, Inspection, and Repair.*
 - (1) Clean all parts with a clean cloth dampened in an approved cleaning solvent, and dry thoroughly.
 - (2) Inspect all parts for damaged or defective condition.
 - (3) Replace or repair damaged or defective parts as necessary.

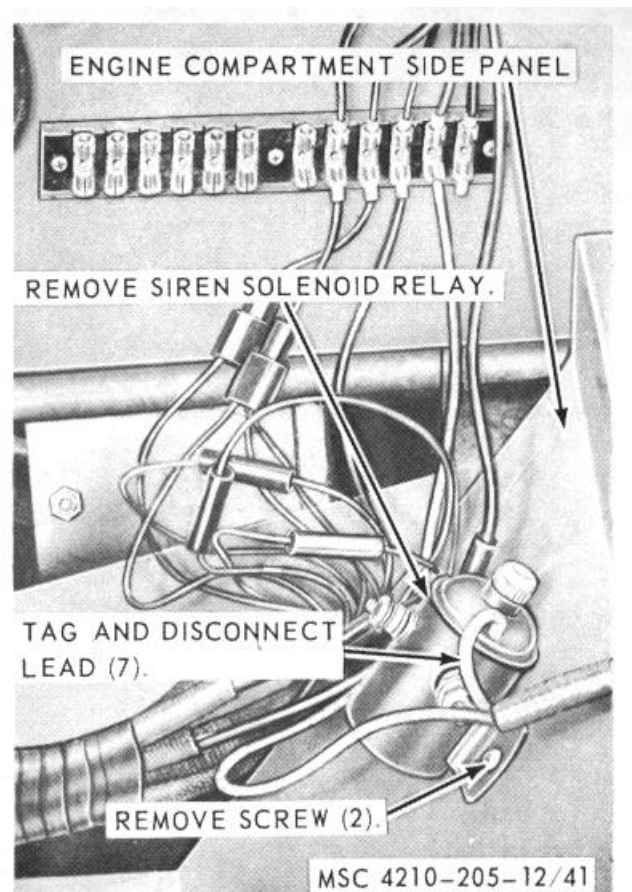

Figure 41. Siren solenoid relay, removal and installation.

- c. *Installation.* Refer to figure 45, and install the circuit breakers on the cab fire wall.

91. Beacon Warning Light Switch

- a. *Removal.* Refer to figure 46, and remove the beacon warning light switch from the instrument panel.
- b. *Cleaning, Inspection, and repair.*
 - (1) Clean all parts with a clean cloth dampened in an approved cleaning solvent, and dry thoroughly.
 - (2) Inspect all parts for damaged or defective condition.
 - (3) Replace or repair damaged or defective parts as necessary.

- c. *Installation.* Refer to figure 46, and install the siren light switch on the instrument Panel.

92. Siren Light Switch

- a. *Removal* Refer to figure 46, and remove the siren light switch from the instrument panel.

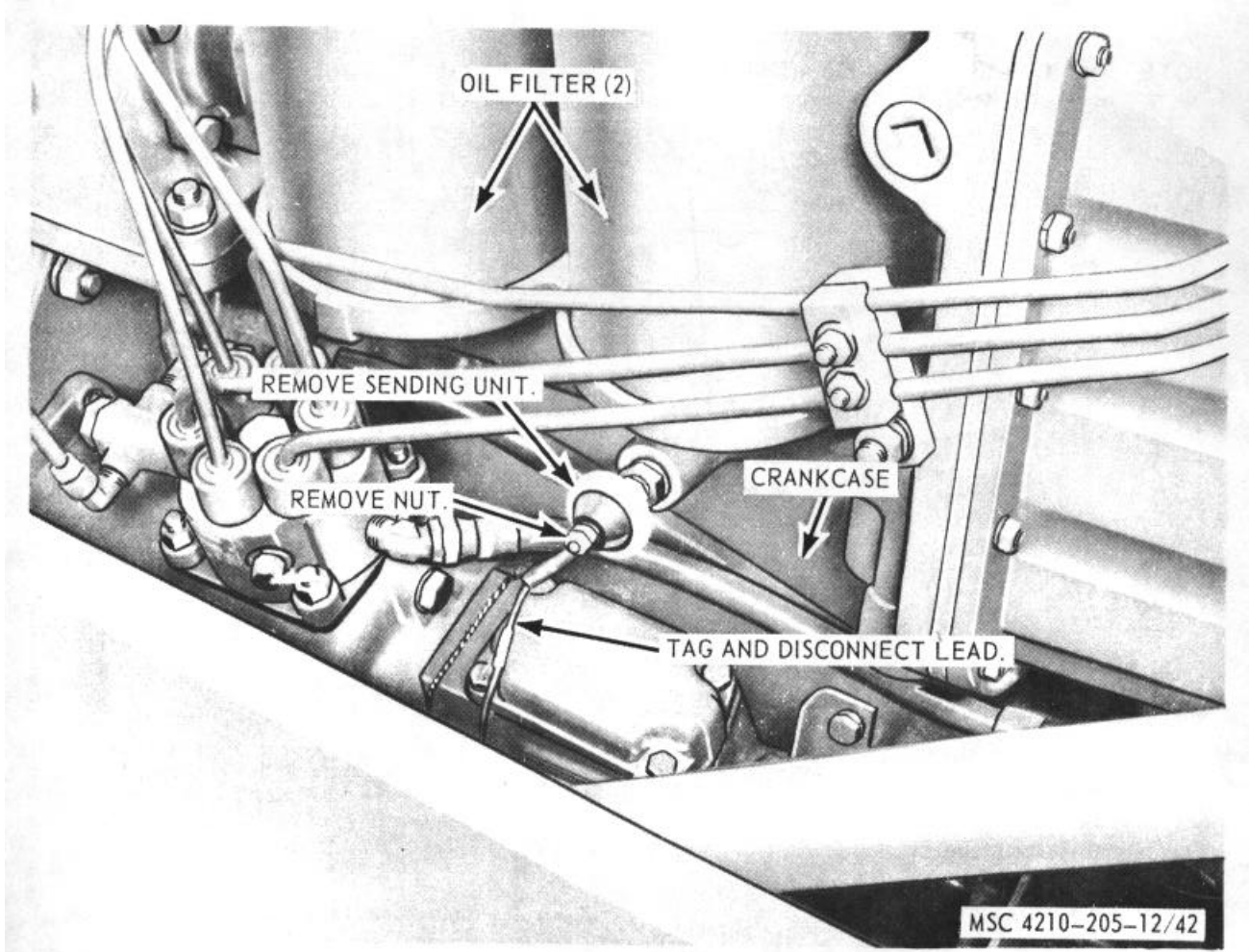

Figure 42. Engine oil pressure sending unit, removal and installation.

b. Cleaning, Inspection, and repair.

- (1) Clean all parts with a clean cloth dampened in an approved cleaning solvent, and dry thoroughly.
- (2) Inspect all parts for damaged or defective condition.
- (3) Replace or repair damaged or defective parts as necessary.

c. Installation. Refer to figure 46, and remove the siren light switch from the instrument panel.

93. Turn Signal Switch

a. Removal. Refer to figure 46, and remove the beacon warning light switch from the instrument panel.

b. Cleaning, Inspection, and repair.

- (1) Clean all parts with a clean cloth dampened in an approved cleaning solvent, and dry thoroughly.

- (2) Inspect all parts for damaged or defective condition.
- (3) Replace or repair damaged or defective parts as necessary.

c. Installation. Refer to figure 46, and remove the siren light switch from the instrument panel.

94. Siren Hand Switch

a. Removal. Refer to figure 46, and remove the beacon warning light switch from the instrument panel.

b. Cleaning, Inspection, and repair.

- (1) Clean all parts with a clean cloth dampened in an approved cleaning solvent, and dry thoroughly.
- (2) Inspect all parts for damaged or defective condition.
- (3) Replace or repair damaged or defective parts as necessary.

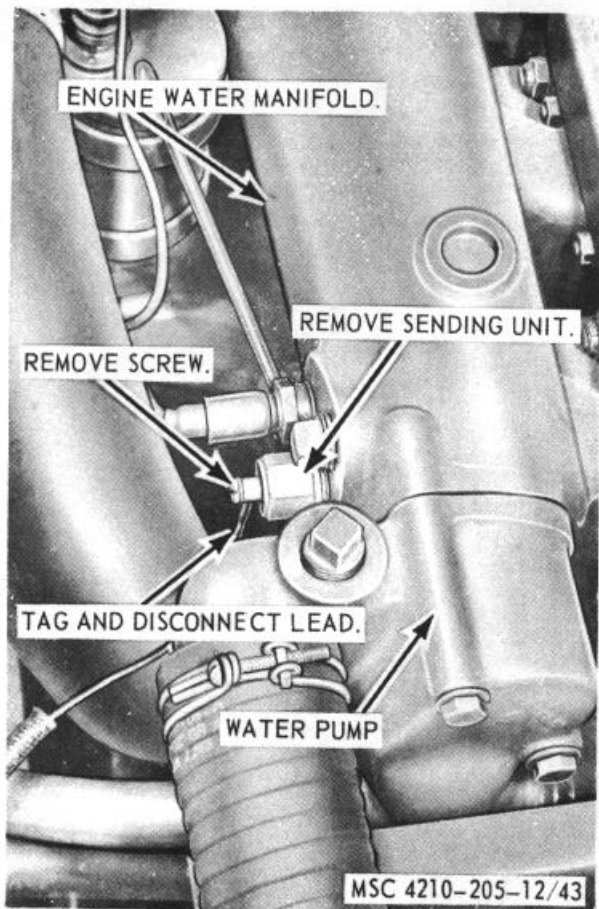

Figure 43. Engine temperature sending unit, removal and installation.

c. *Installation.* Refer to figure 46, and install the siren light switch on the steering column.

95. Siren Foot Switch

a. *Removal.* Refer to figure 47, and remove the beacon warning light switch from the instrument panel.

b. *Cleaning, Inspection, and repair.*

- (1) Clean all parts with a clean cloth dampened in an approved cleaning solvent, and dry thoroughly.
- (2) Inspect all parts for damaged or defective condition.
- (3) Replace or repair damaged or defective parts as necessary.

c. *Installation.* Refer to figure 47, and remove the siren light switch from the instrument. Panel.

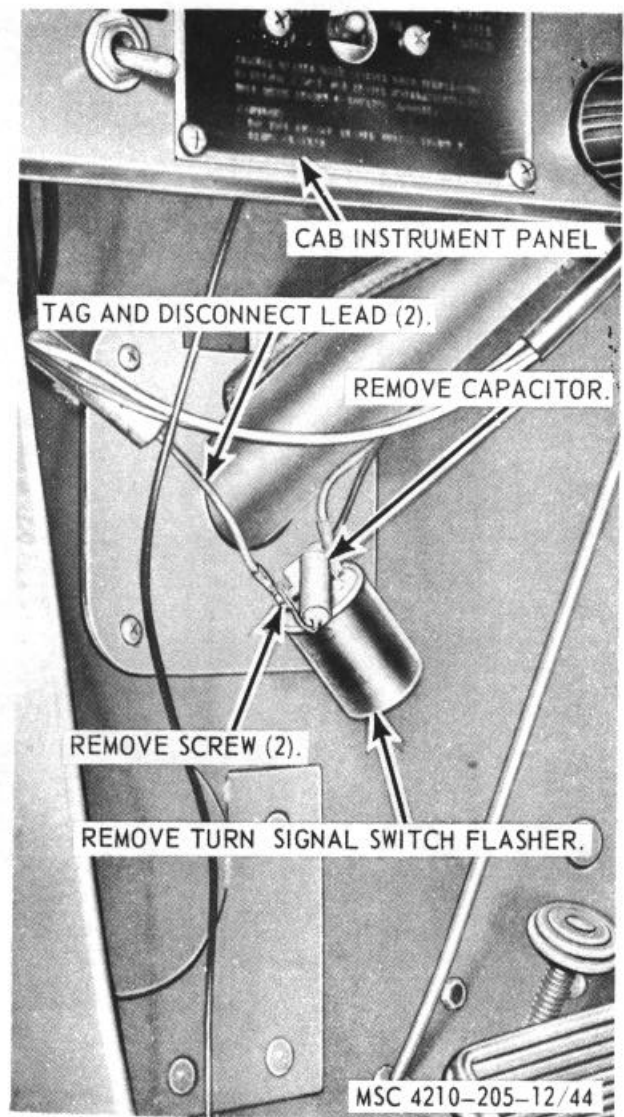

Figure 44. Flasher assembly, removal and installation.

96. Pump Gage Panel Warning Light

a. *Removal.* Refer to figure 48, and remove the pump gage panel warning light from the pump gage panel.

b. *Cleaning, Inspection, and Repair.*

- (1) Clean all parts with a clean cloth dampened in an approved cleaning solvent, and dry thoroughly.
- (2) Inspect all parts for damaged or defective condition.
- (3) Inspect lamp for cracks, breaks, or burned out condition.
- (4) Replace or repair damaged or defective parts as necessary.

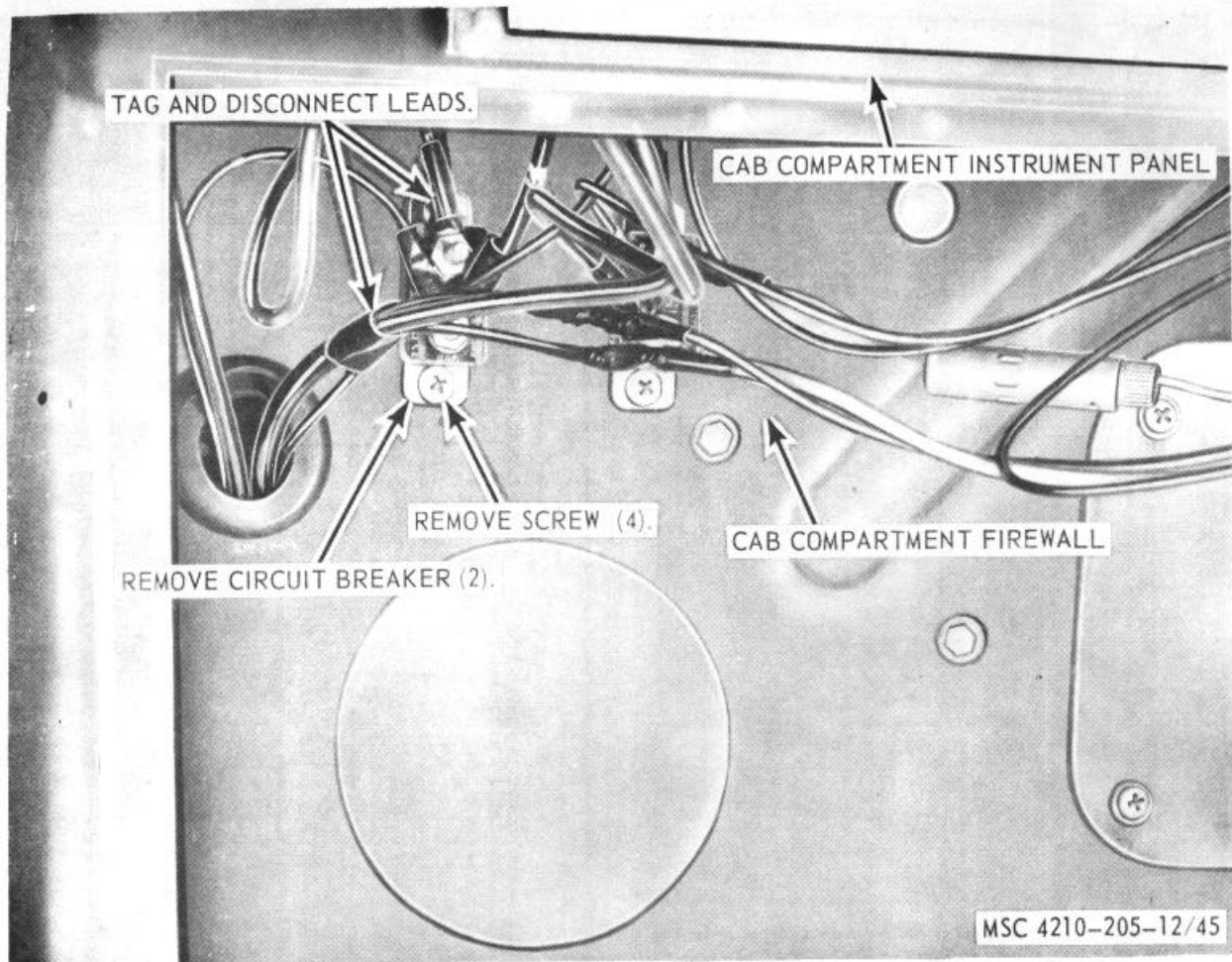

Figure 45. Circuit breakers, removal and installation.

c. Installation. Refer to figure 48, and install the pump gage panel warning light on the pump gage panel.

97. Pump Gage Panel Light

a. Removal. Refer to figure 48, and remove the pump gage panel warning light from the pump gage panel.

b. Cleaning, Inspection, and Repair.

- (1) Clean all parts with a clean cloth dampened in an approved cleaning solvent, and dry thoroughly.
- (2) Inspect all parts for damaged or defective condition.
- (3) Inspect lamp for cracks, breaks, or burned out condition.
- (4) Replace or repair damaged or defective parts as necessary.

c. Installation. Refer to figure 48, and install the pump gage panel warning light on the pump gage panel.

98. Dome Light

a. Removal. Refer to figure 49, and remove the dome light from the special purpose body.

b. Cleaning, Inspection, and Repair.

- (1) Clean all parts with a clean cloth dampened in an approved cleaning solvent, and dry thoroughly.
- (2) Inspect all parts for damaged or defective condition.
- (3) Inspect lamp for cracks, breaks, or burned out condition.
- (4) Replace or repair damaged or defective parts as necessary.

c. Installation. Refer to figure 49, and install the dome light on the special purpose body.

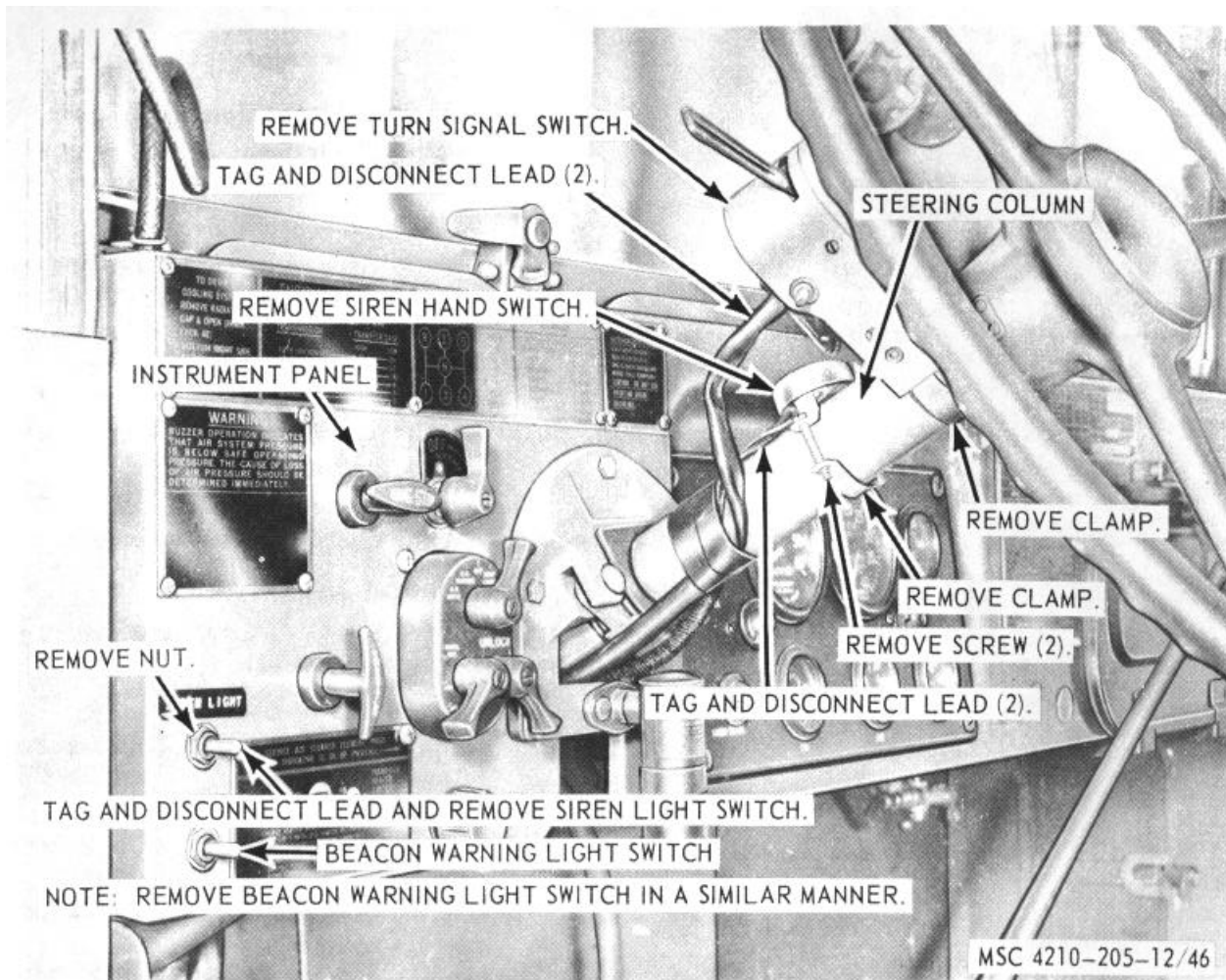

Figure 46. Beacon warning light switch and siren light switch, removal and installation.

99. Dome Light Switch

a. Removal. Refer to figure 49, and remove the dome light switch from the instrument panel.

b. Cleaning, Inspection, and Repair.

- (1) Clean all parts with a clean cloth dampened in an approved cleaning solvent, and dry thoroughly.
- (2) Inspect all parts for damaged or defective condition.
- (3) Inspect lamp for cracks, breaks, or burned out condition.
- (4) Replace or repair damaged or defective parts as necessary.

c. Installation. Refer to figure 49, and install the dome light on the instrument panel.

100. Pump Gage Panel Light Switch

a. Removal. Refer to figure 49, and remove the pump gage panel light from the instrument panel.

b. Cleaning, Inspection, and Repair.

- (1) Clean all parts with a clean cloth dampened in an approved cleaning solvent, and dry thoroughly.
- (2) Inspect all parts for damaged or defective condition.
- (3) Inspect lamp for cracks, breaks, or burned out condition.
- (4) Replace or repair damaged or defective parts as necessary.

c. Installation. Refer to figure 49, and install the pump gage panel light switch on the instrument panel.

101. Engine Light Switch

a. Removal. Refer to figure 49, and remove the engine light switch from the instrument panel.

b. Cleaning, Inspection, and Repair.

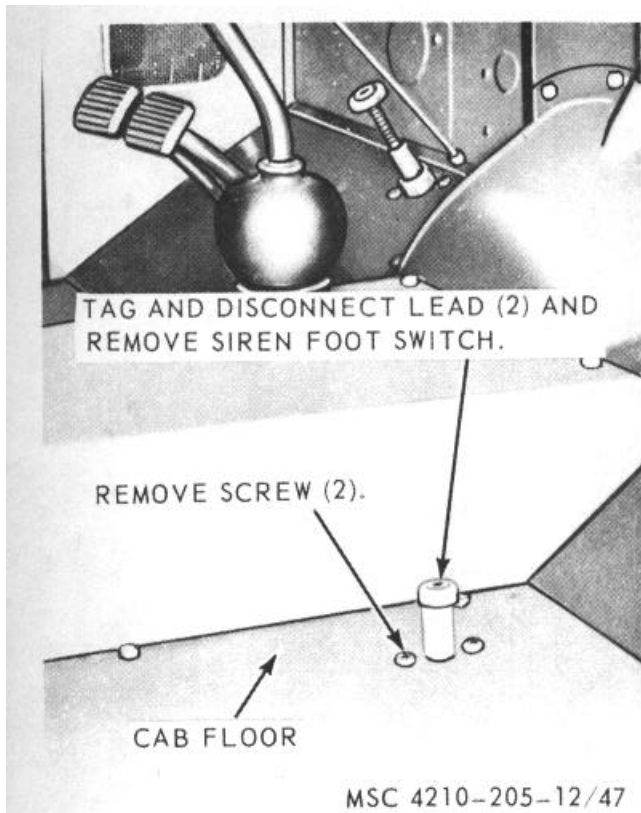

Figure 47. Siren foot switch, removal and installation.

- (1) Clean all parts with a clean cloth dampened in an approved cleaning solvent, and dry thoroughly.
- (2) Inspect all parts for damaged or defective condition.
- (3) Replace or repair damaged or defective parts as necessary.

c. Installation. Refer to figure 49, and install the engine light switch on the instrument panel.

102. Hose Reel Switch

a. Removal. Refer to figure 49, and remove the hose reel switch from the instrument panel.

b. Cleaning, Inspection, and Repair.

- (1) Clean all parts with a clean cloth dampened in an approved cleaning solvent, and dry thoroughly.
- (2) Inspect all parts for damaged or defective condition.
- (3) Replace or repair damaged or defective parts as necessary.

c. Installation. Refer to figure 49, and install the hose reel switch on the instrument panel.

103. Hose Reel Motor Solenoid Relay

a. Removal. Refer to figure 50, and remove the hose reel motor solenoid relay from the hose reel.

b. Cleaning, Inspection, and Repair.

- (1) Clean all parts with a clean cloth dampened in an approved cleaning solvent, and dry thoroughly.
- (2) Inspect all parts for damaged or defective condition.
- (3) Inspect lamp for cracks, breaks, or burned out condition.
- (4) Replace or repair damaged or defective parts as necessary.

c. Installation. Refer to figure 50, and install the hose reel motor solenoid relay on the hose reel.

104. Hose Reel Motor

a. Removal. Refer to figure 50, and remove the hose reel motor from the hose reel.

b. Cleaning, Inspection, and Repair.

- (1) Clean all parts with a clean cloth dampened in an approved cleaning solvent, and dry thoroughly.
- (2) Inspect all parts for damaged or defective condition.
- (3) Inspect lamp for cracks, breaks, or burned out condition.
- (4) Replace or repair damaged or defective parts as necessary.

c. Installation. Refer to figure 50, and install the hose reel motor on the hose reel.

105. Primer Pump Motor Solenoid Relay

a. Removal. Refer to figure 51, and remove the primer pump motor solenoid relay from the primer pump.

b. Cleaning, Inspection, and Repair.

- (1) Clean all parts with a clean cloth dampened in an approved cleaning solvent, and dry thoroughly.
- (2) Inspect all parts for damaged or defective condition.
- (3) Inspect lamp for cracks, breaks, or burned out condition.
- (4) Replace or repair damaged or defective parts as necessary.

c. Installation. Refer to figure 51, and install the primer pump motor solenoid relay on the primer pump.

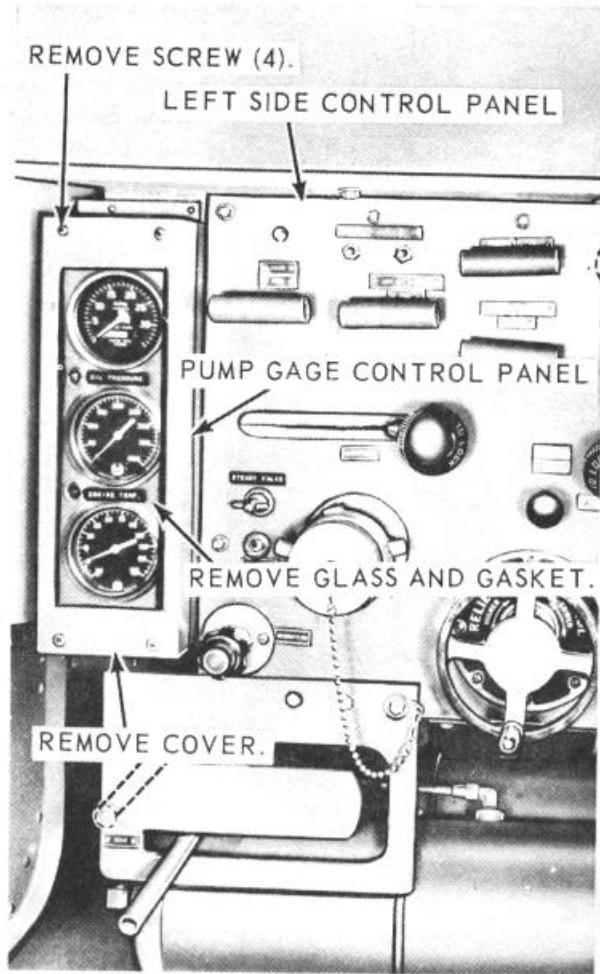

A

A-Cover removal

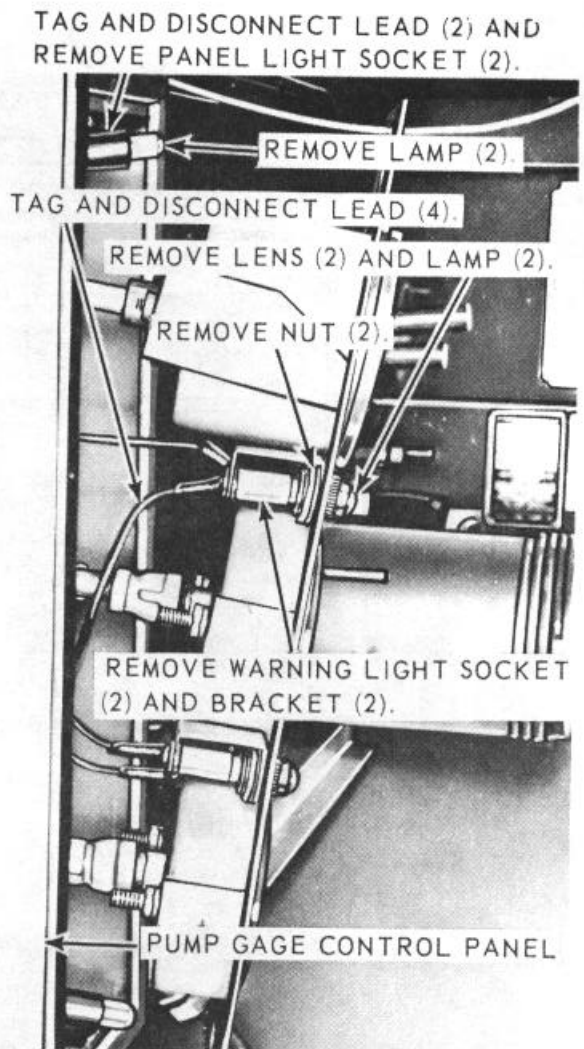

B

B-Lamp and socket removal

MSC 4210-205-12/48

Figure 48. Warning lights and panel lights, removal and installation.

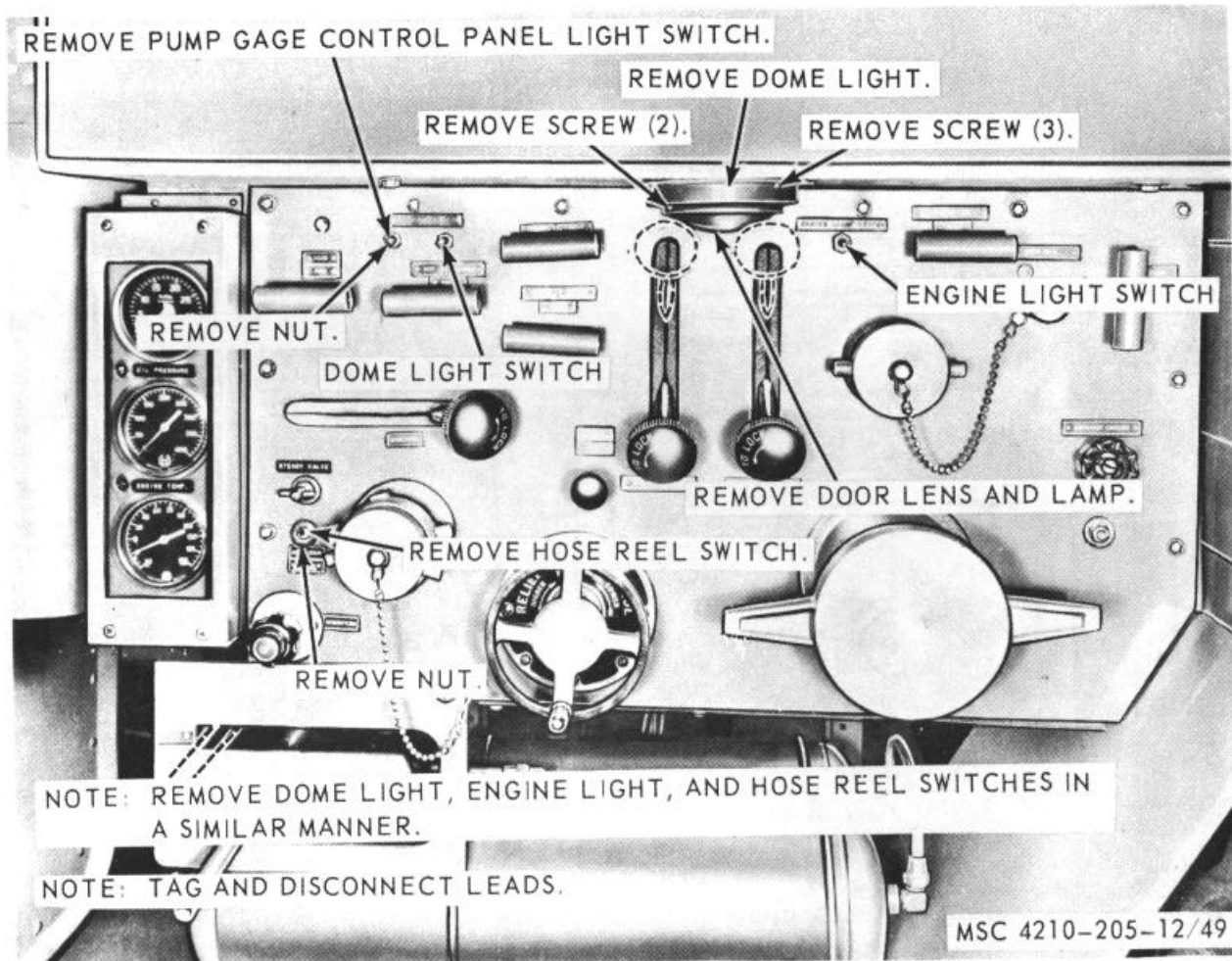

Figure 49. Dome light, and electrical control switches, removal and installation.

106. Primer Pump Motor

a. Removal. Refer to figure 51, and remove the primer pump motor from the primer pump.

b. Cleaning, Inspection, and Repair.

- (1) Clean all parts with a clean cloth dampened in an approved cleaning solvent, and dry thoroughly.
- (2) Inspect all parts for damaged or defective condition.
- (3) Replace or repair damaged or defective parts as necessary.

c. Installation. Refer to figure 51, and install the primer pump motor on the primer pump.

107. Microswitch

a. Removal. Refer to figure 51, and remove the microswitch from the primer valve.

b. Cleaning, Inspection, and Repair.

- (1) Clean all parts with a clean cloth dampened in an approved cleaning solvent, dry thoroughly.
- (2) Inspect all parts for damaged or defective condition.
- (3) Replace or repair damaged or defective parts as necessary.

c. Installation. Refer to figure 51, and install the microswitch on the primer valve.

108. Rear Floodlight

a. Removal. Refer to figure 52, and remove the rear floodlight from the fire truck body.

b. Cleaning, Inspection, and Repair.

- (1) Clean all parts with a clean cloth dampened in an approved cleaning solvent, and dry thoroughly.

DRIVE CHAIN ADJUSTMENT:

LOOSEN SCREW (4), MOVE MOTOR UP TO LOOSEN CHAIN, AND DOWN TO TIGHTEN CHAIN.
TIGHTEN SCREW (4). CHAIN DEFLECTION SHOULD BE 1/8 INCH BETWEEN DRIVES.

NOTE: REMOVE REMAINING MOTOR AND SOLENOID AND ADJUST REMAINING CHAIN
IN A SIMILAR MANNER.

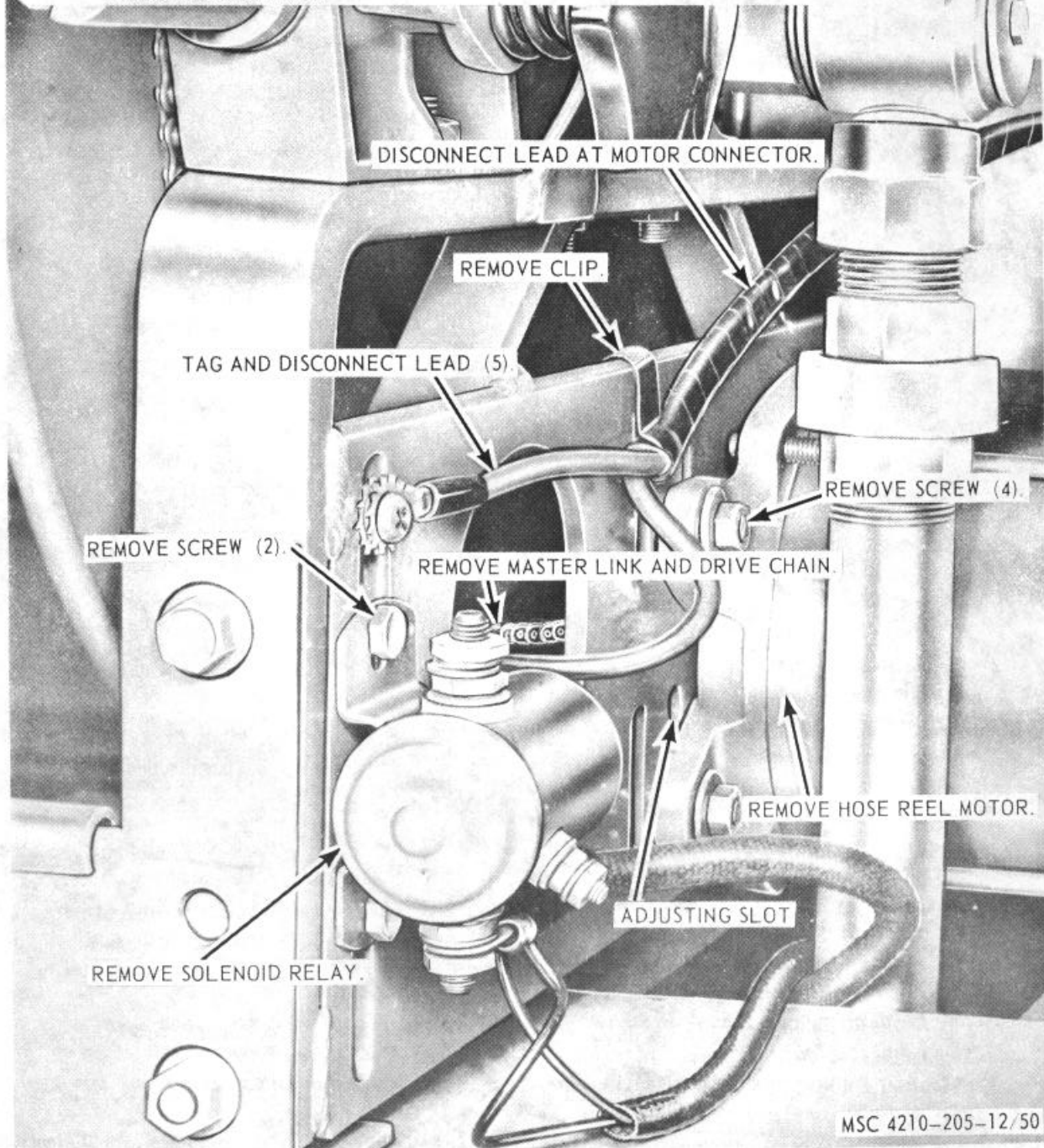

Figure 50. Hose reel motor and solenoid relay, removal and installation

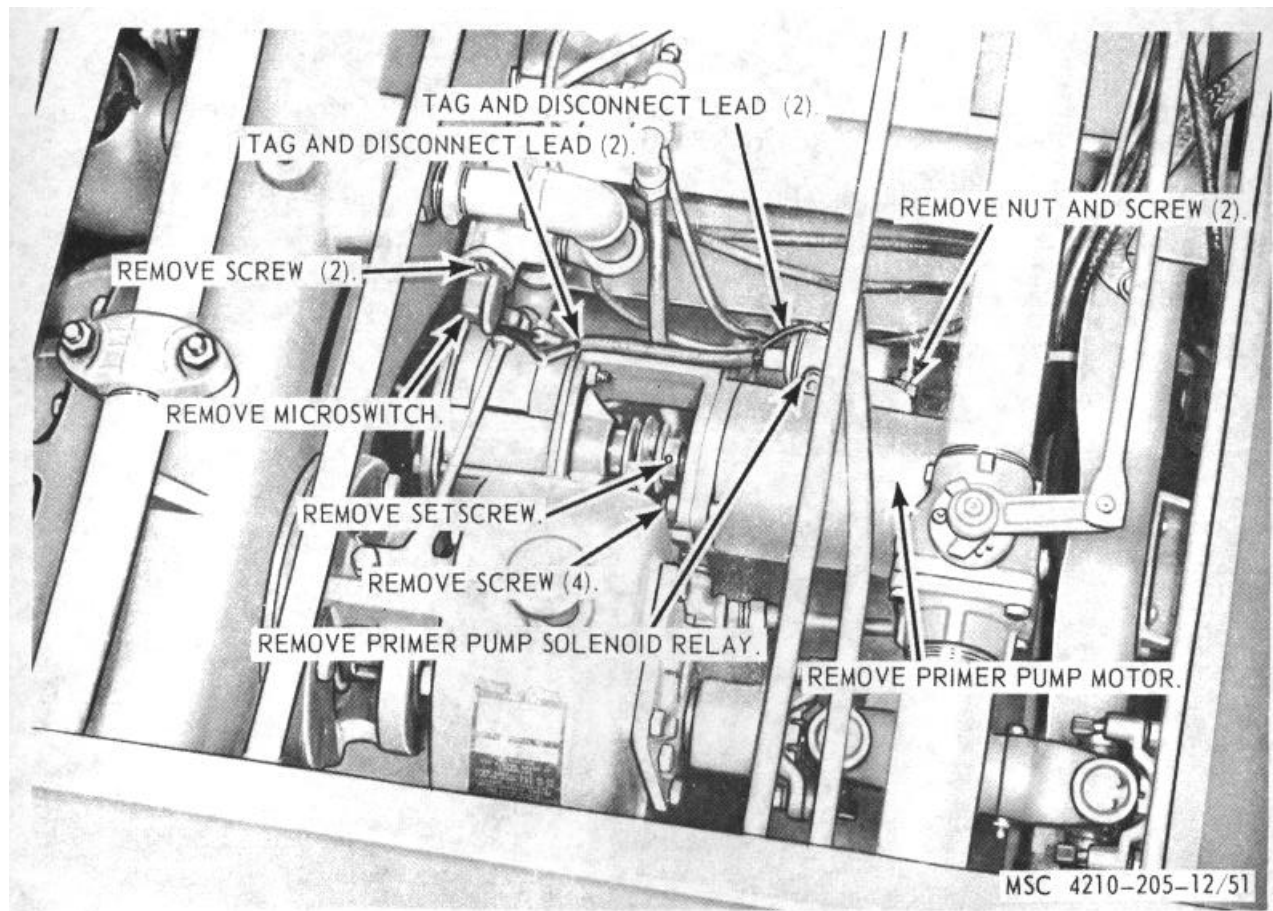

Figure 51. Primer pump solenoid, primer pump, and motor, removal and installation.

- (2) Inspect door, gasket, and body for damaged or defective condition.
- (3) Inspect lamp for crack, breaks, or burned out condition.
- (4) Replace or repair damaged or defective parts as necessary.

c. *Installation.* Refer to figure 52, and install the rear floodlight on the fire truck body.

109. Rear Directional Light

a. *Removal.* Refer to figure 53, and remove the rear directional light from the fire truck panel.

b. *Cleaning, Inspection, and Repair.*

- (1) Clean all parts with a clean cloth dampened in an approved cleaning solvent, and dry thoroughly.
- (2) Inspect lens, gasket for damaged or defective condition.
- (3) Inspect lamp for cracks, breaks, or burned out condition.

- (4) Replace or repair damaged or defective parts as necessary.

c. *Installation.* Refer to figure 53, and install the rear directional light on tile fire truck panel.

110. Taillights

a. *Removal.* Refer to figure 53, and remove the taillights from the fire truck panel.

b. *Cleaning, Inspection, and Repair.*

- (1) Clean all parts with a clean cloth dampened in an approved cleaning solvent, and dry thoroughly.
- (2) Inspect lens, gaskets, and door for damaged or defective condition.
- (3) Inspect lamp for cracks, breaks, or burned out condition.
- (4) Replace or repair damaged or defective parts as necessary.

c. *Installation.* Refer to figure 53, and install the taillights on the fire truck panel.

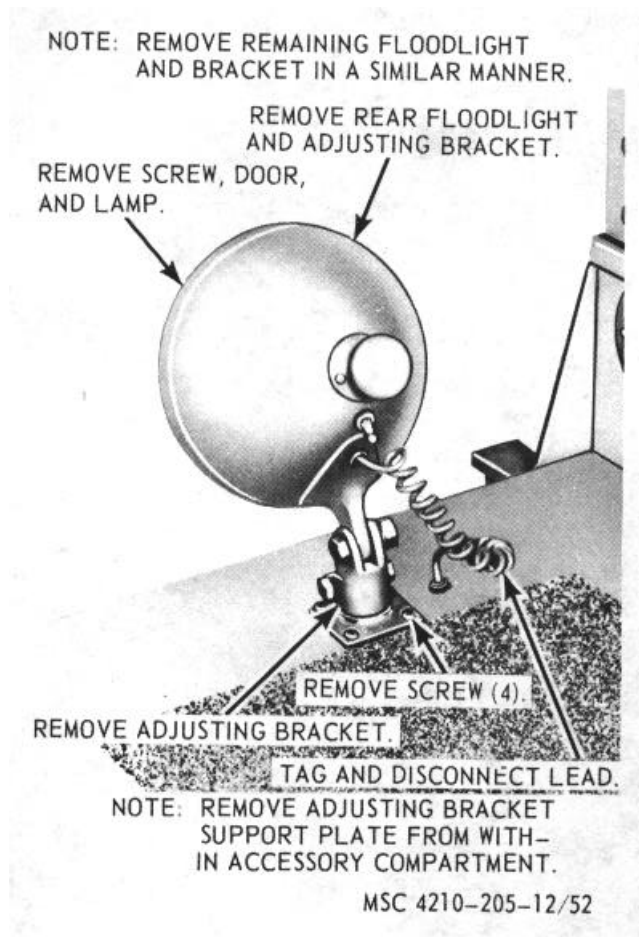

Figure 52. Rear floodlight, removal and installation.

111. Battery Charging Receptacles

a. *Removal.* Refer to figure 53, and remove the battery charging receptacles from the rear apron.

b. *Cleaning, Inspection, and Repair.*

- (1) Clean all parts with a clean cloth dampened in an approved cleaning solvent, and dry thoroughly.
- (2) Inspect all parts for damaged or defective condition.
- (3) Replace or repair damaged or defective parts as necessary.

c. *Installation.* Refer to figure 53, and install the battery charging receptacles on the rear apron.

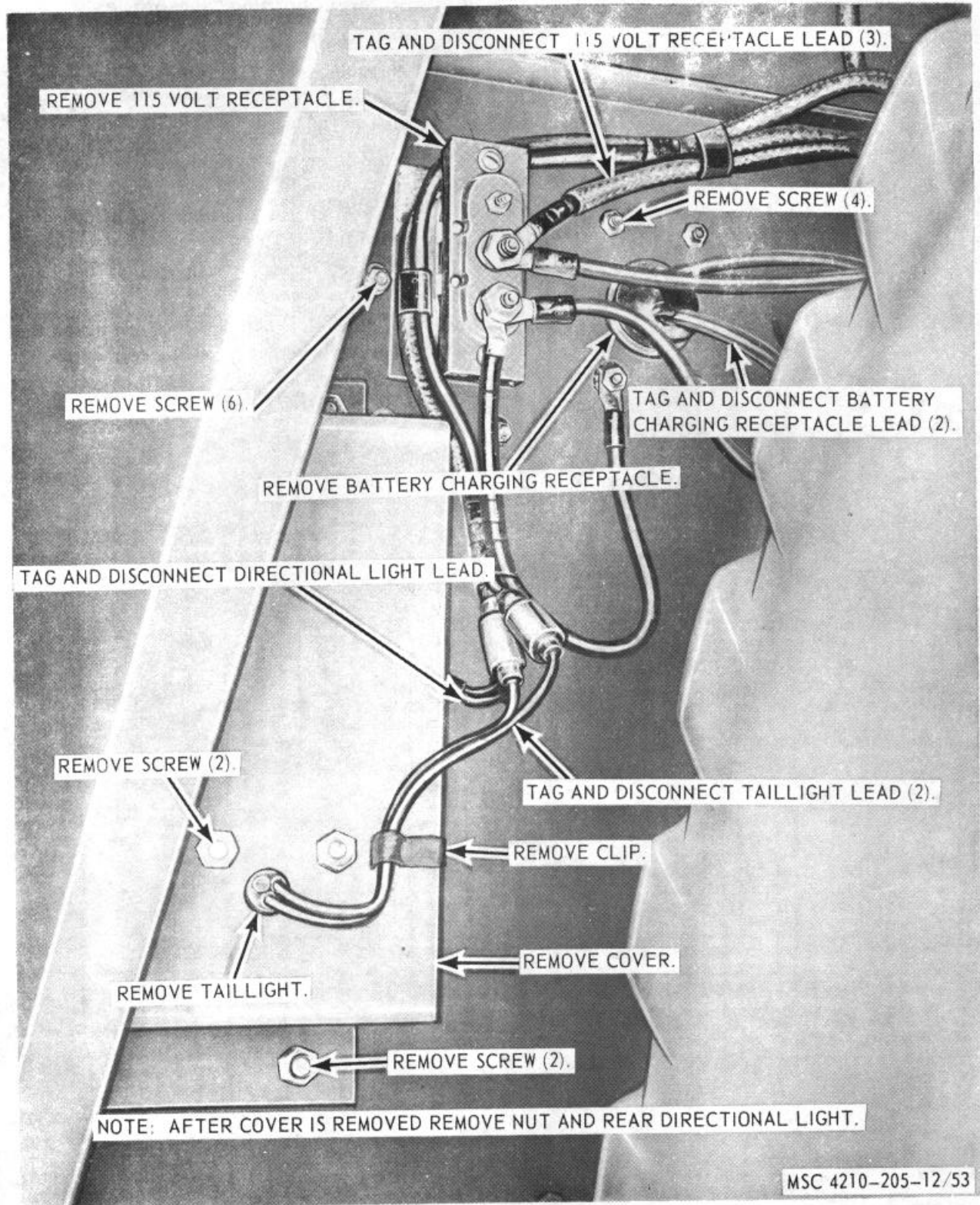

Figure 53. Rear directional light and taillight, removal and installation.

Section XII. CONTROLS, INSTRUMENTS AND PANELS

112. General

The controls and instruments are primarily located on the operators instrument panels located on the left and right sides of the fire truck below the hose reel compartments. The pump gage panel is located near the left-hand instrument panel. It houses the tachometer-hourmeter which registers the engine rpm and hours of operation. The pump discharge pressure gage determines the water discharge pressure, and the hydrant pressure and vacuum gage determines the hydrant pressure. A throttle control located on the left instrument panel operates the engine speed. The apron is mounted to the special purpose body at the rear of the fire truck.

There is a pump compartment bottom panel located below and mounted to the pump compartment frame.

113. Right Side Control Panel

a. Removal.

- (1) Remove the hose reel switch (para. 102).
- (2) Refer to figure 54, and remove the right side control panel from the pump compartment.

b. Cleaning, Inspection, and Repair.

- (1) Clean all parts with an approved cleaning solvent, and dry thoroughly.
- (2) Inspect all parts for damaged or defective condition.

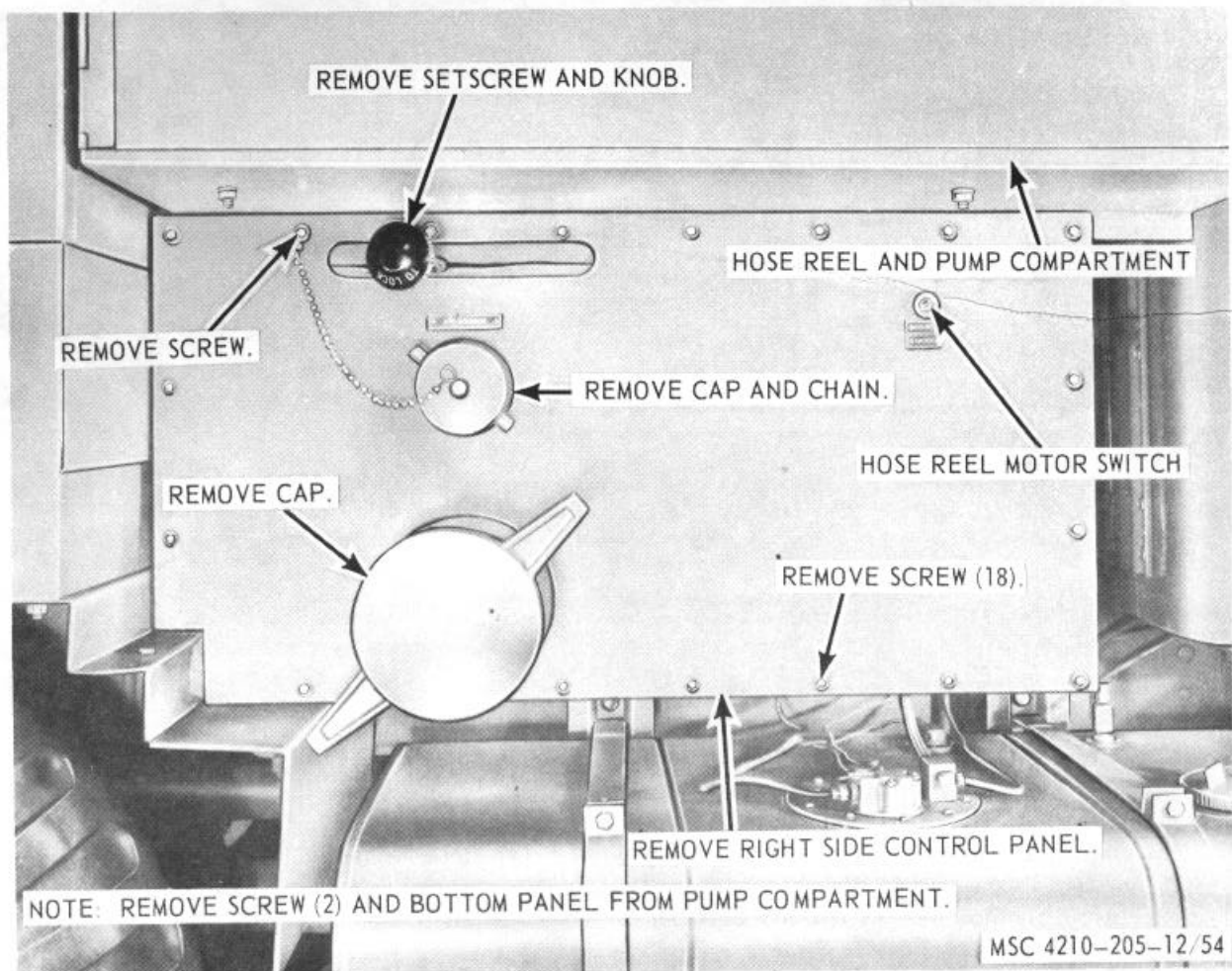

Figure 54. Right side control panels, removal and installation.

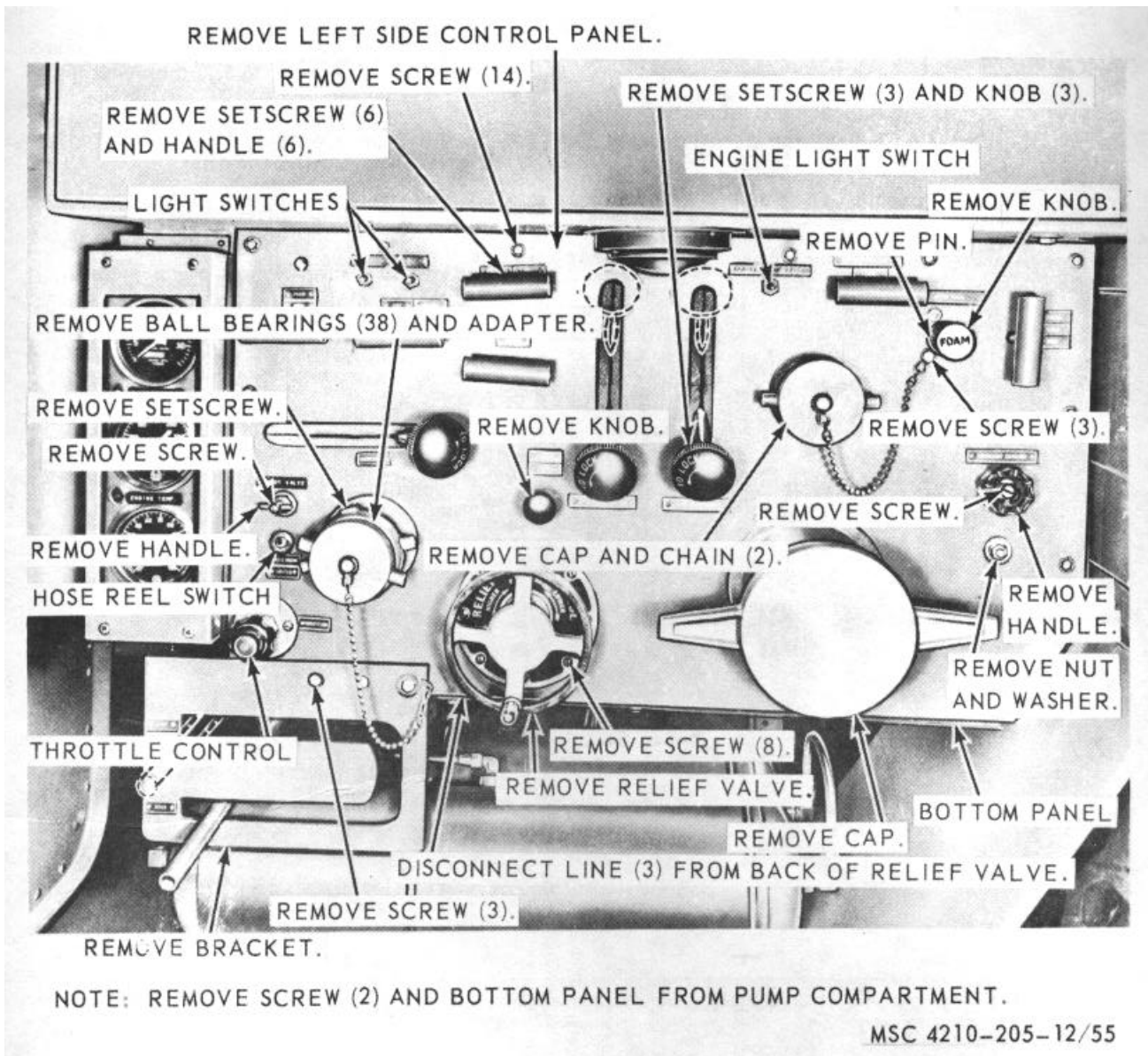

Figure 55. Left side control panels, removal and installation.

- (3) Replace or repair damaged or defective parts as necessary.

c. Installation.

- (1) Refer to figure 54, and install the right side control panels on the pump compartment.
 (2) Install the hose reel switch (para. 102).

114. Left Side Control Panel

a. Removal.

- (1) Remove the throttle control (para. 76).

- (2) Remove the hose reel switch (para. 102).

- (3) Remove the engine dome and pump gage control panel lights switch (paras. 99, 100, and 101).

- (4) Refer to figure 55, and remove the left side control panel and bottom panel from the pump compartment.

b. Cleaning, Inspection, and Repair.

- (1) Clean all parts with an approved cleaning solvent, and dry thoroughly.

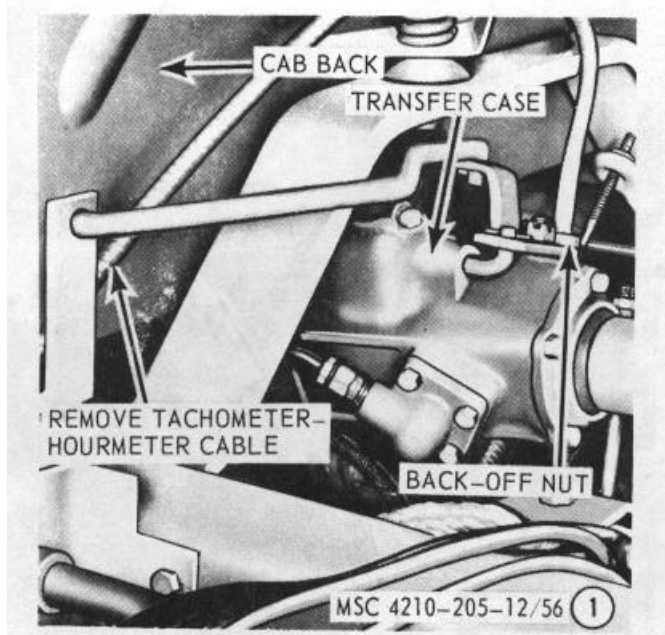

Figure 56. Tachometer-hourmeter, pump control panel, and gages, removal and installation.

- (2) Inspect all parts for damaged or defective condition.
- (3) Replace or repair damaged or defective parts as necessary.

c. Installation.

- (1) Refer to figure 55, and install the left side control panel and bottom panel on the pump compartment.
- (2) Install the engine, dome and pump gage control panel light switch (paras. 99, 100, and 101).
- (3) Install the hose reel switch (para. 102).
- (4) Install the throttle control (para. 76).

115. Tachometer-Hourmeter

a. Removal.

- (1) Refer to figure 48, and remove the cover.
- (2) Refer to figure 56, and remove the tachometer-hourmeter from the pump gage panel and transfer case.

b. Cleaning, Inspection, and Repair.

- (1) Clean all parts with a clean cloth dampened in an approved cleaning solvent, and dry thoroughly.
- (2) Inspect all parts for damaged or defective condition.
- (3) Replace or repair damaged or defective parts as necessary.

c. Installation.

- (1) Refer to figure 56, and install the tachometer-hourmeter on the pump gage panel and transfer case.
- (2) Refer to figure 48, and install the cover.

116. Discharge Pressure Gage

a. Removal.

- (1) Refer to figure 48, and remove the cover.
- (2) Refer to figure 56, and remove the discharge pressure gage from the pump gage panel.

b. Cleaning, Inspection, and Repair.

- (1) Clean all parts with an approved cleaning solvent, and dry thoroughly.
- (2) Inspect all parts for damaged or defective condition.
- (3) Replace or repair damaged or defective parts as necessary.

c. Installation.

- (1) Refer to figure 56, and install the discharge pressure gage on the pump gage panel.
- (2) Refer to figure 48, and install the cover.

117. Vacuum and Hydrant Pressure Gage

a. Removal.

- (1) Refer to figure 48, and remove the cover.
- (2) Refer to figure 56, and remove the hydrant pressure gage from the pump gage panel.

b. Cleaning, Inspection, and Repair.

- (1) Clean all parts with an approved cleaning solvent, and dry thoroughly.
- (2) Inspect all parts for damaged or defective condition.
- (3) Replace or repair damaged or defective parts as necessary.

c. Installation.

- (1) Refer to figure 56, and install the vacuum hydrant pressure gage on the pump gage panel.
- (2) Refer to figure 48, and install the cover.

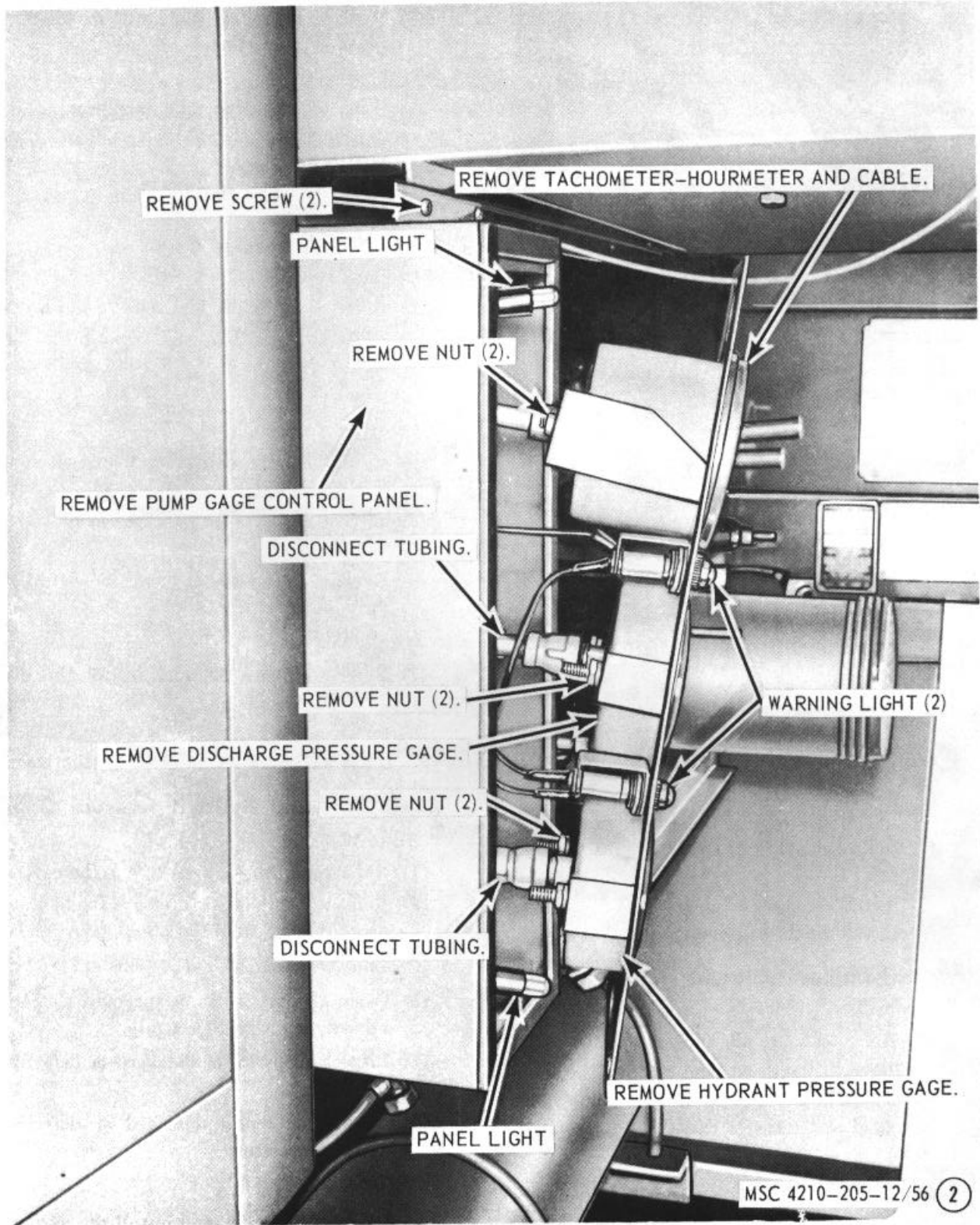

Figure 56-Continued.

118. Pump Gage Control Panel

a. Removal.

- (1) Remove the tachometer-hourmeter (para. 115).
- (2) Remove the vacuum hydrant pressure gage (para. 117).
- (3) Discharge pressure gage (para. 116).
- (4) Refer to figure 56, and remove the pump gage control panel from the special purpose body.

b. Cleaning, Inspection, and Repair.

- (1) Clean all parts with an approved cleaning solvent, and dry thoroughly.
- (2) Inspect all parts for damaged or defective condition.

- (3) Replace or repair damaged or defective parts as necessary.

c. Installation.

- (1) Refer to figure 56, and install the pump gage panel on the special purpose body.
- (2) Install the discharge pressure gage (para. 116).
- (3) Install the hydrant pressure gage (para. 117).
- (4) Install the tachometer-hourmeter (para. 115).

119. Apron

a. Removal.

- (1) Remove the rear directional and taillights (paras. 109 and 110).

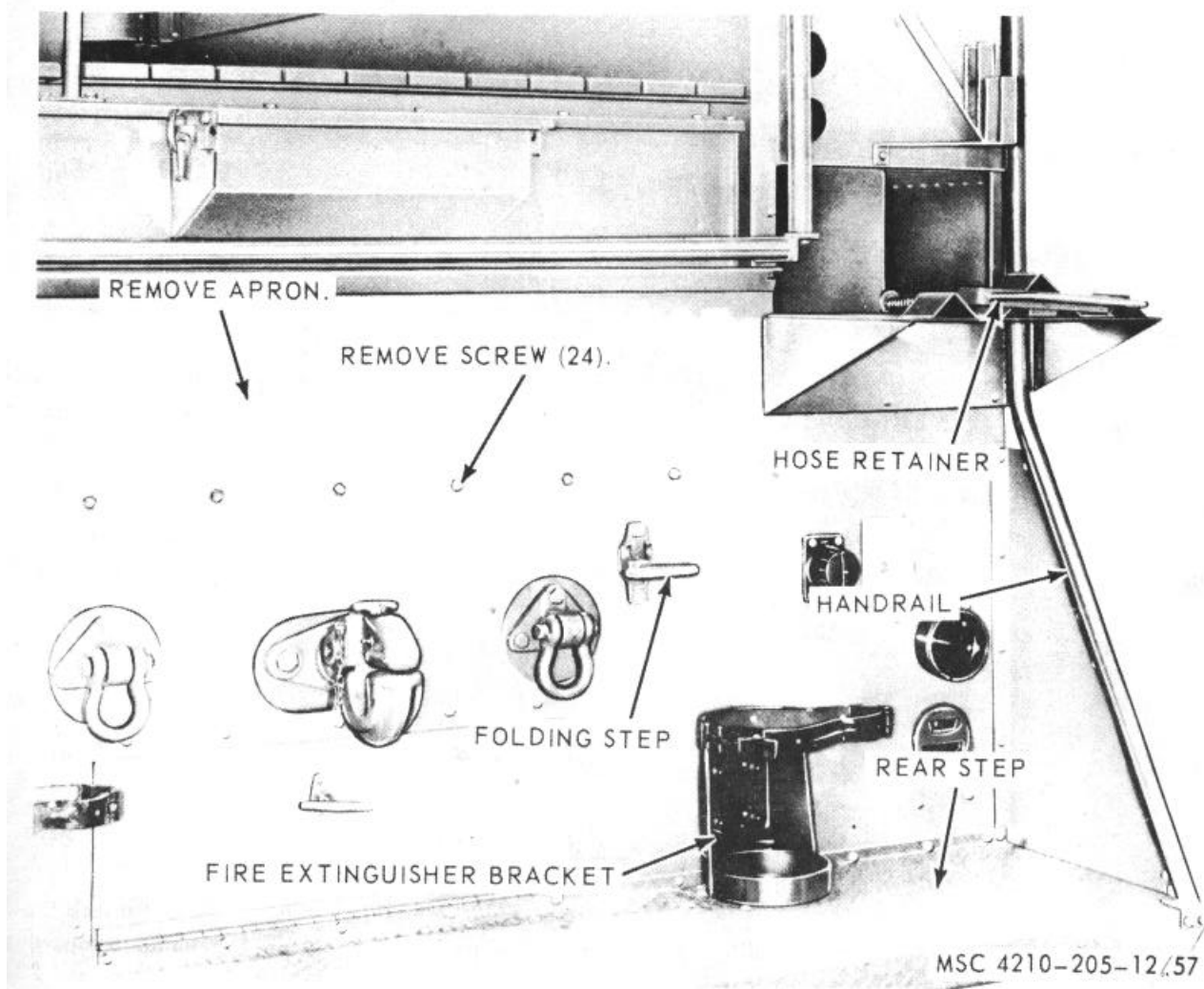

Figure 57. Apron, removal and installation.

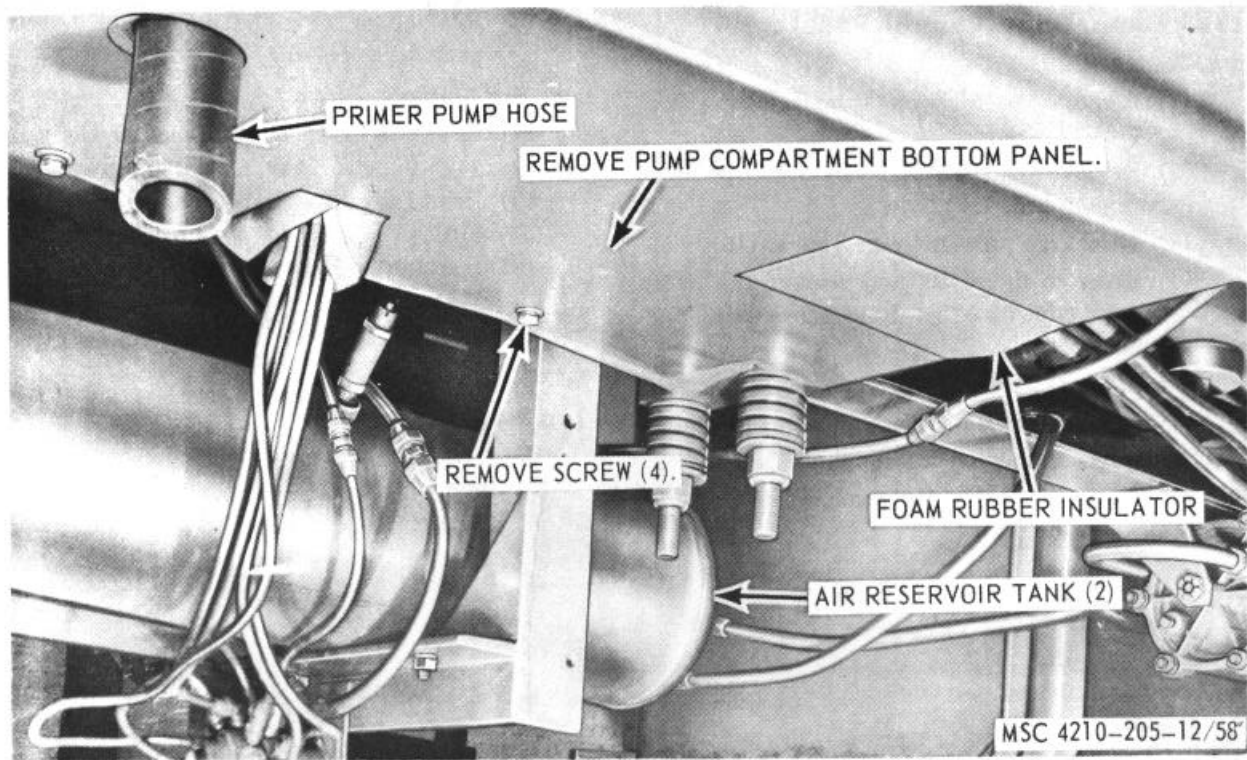

Figure 58. Pump compartment panel, removal and installation.

- (2) Remove the rear step (para. 61).
- (3) Remove the hose retainers (paras. 64 and 65).
- (4) Remove the receptacles (para. 111).
- (5) Remove the shovel bracket (para. 62).
- (6) Remove the folding step (para. 66).
- (7) Refer to figure 57, and remove the apron from the special purpose body.

b. Cleaning, Inspection, and Repair.

- (1) Clean all parts *with a clean cloth dampened in an approved cleaning solvent, and dry thoroughly.
- (2) Inspect all parts for damaged or defective condition.
- (3) Replace or repair damaged or defective parts as necessary.

c. Installation.

- (1) Refer to figure 57, and install the apron on the special purpose body.
- (2) Install the folding step (para. 66).

- (3) Install the shovel bracket (para. 62).
- (4) Install the receptacles (para. 111).
- (5) Install the hose retainers (paras. 64 and 65).
- (6) Install the rear step (para. 61).
- (7) Install the rear directional and taillights (paras. 109 and 110).

120. Pump Compartment Panel

a. Removal. Refer to figure 58, and remove the pump compartment panel from the pump compartment.

b. Cleaning, Inspection, and Repair.

- (1) Clean all parts with an approved cleaning solvent, and dry thoroughly.
- (2) Inspect all parts for damaged or defective condition.
- (3) Replace or repair damaged or defective parts as necessary.

c. Installation. Refer to figure 58, and install the pump compartment panel on the pump compartment.

Section XIII. PUMPING SYSTEM

121. General

The fire truck pumping system consists of a centrifugal-type pump, rotary vacuum priming pump, steady valve, relief valve, water tank, foam, and two motor driven hose reels. A series of operating valves, drain valves, and a foam proportion regulator, regulate operation of the fire pump for pumping water, or a water and foam combination. The centrifugal-type pump develops pressure and capacity, by means of centrifugal force, and must be primed before it will lift water. The priming system consists of a rotary vacuum pump operated by a 24-volt electric motor controlled through a manual priming valve which actuates a microswitch controlling the electric motor. Water pressure is controlled manually by a throttle knob and is held automatically by the relief valve. The relief valve is adjusted to any pump pressure up to 300 psi. The hose reels are electric motor driven, and actuated by a reel

rewind button, located beneath the hose reel assemblies on the instrument panel. The heat exchanger is mounted in the engine compartment, and circulates water through the engine cooling system from the pumping system to cool the engine. The primer oil tank is mounted on the engine cab beneath the right-hand seat. It supplies oil to the primer pump.

122. Primer Pump

a. Removal.

- (1) Remove the primer pump motor and solenoid relay (para. 105).
- (2) Refer to figure 59, and remove the primer pump from the water pump manifold.

b. Cleaning, Inspection., and Repair.

- (1) Clean all parts with an approved cleaning solvent, and dry thoroughly.

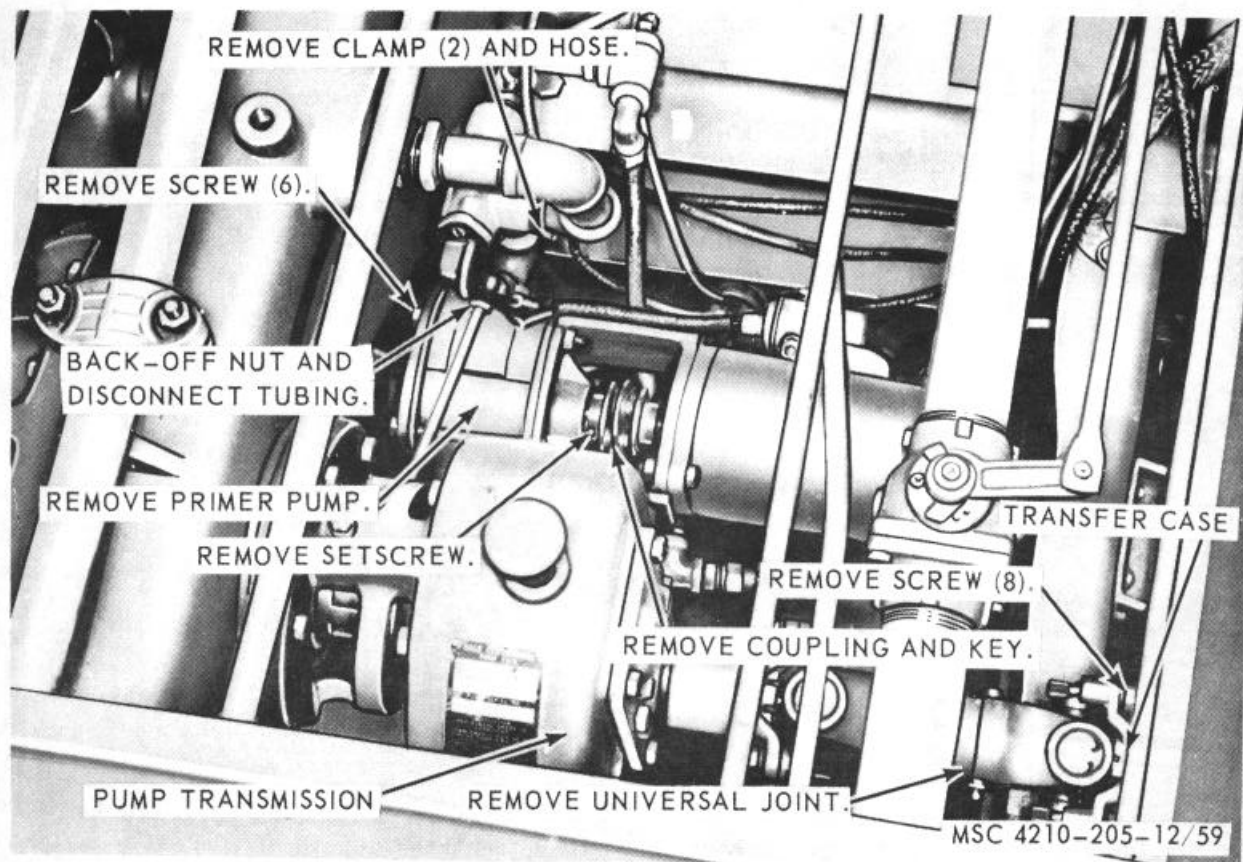
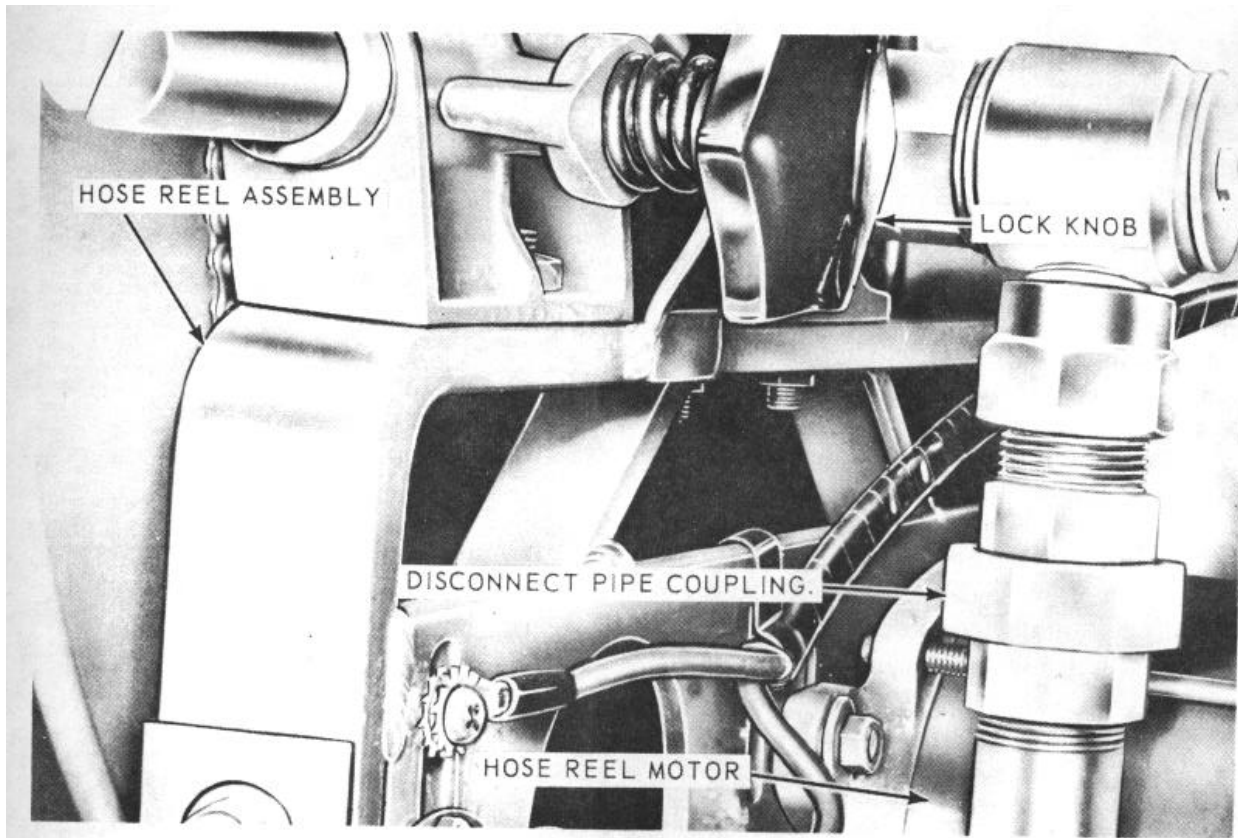
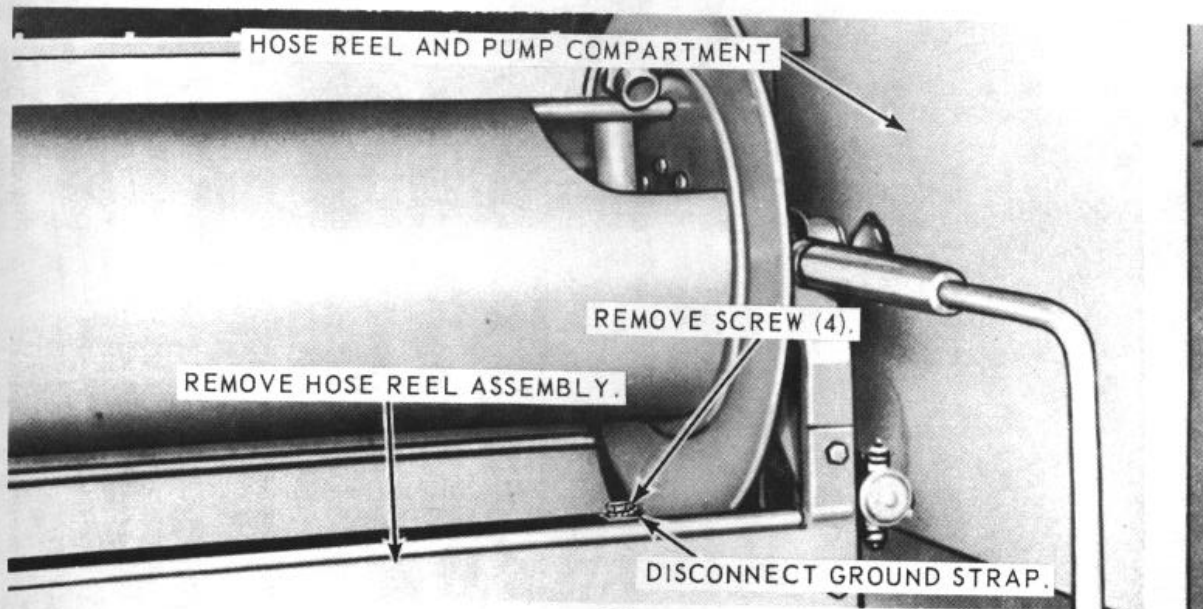

Figure 5.9. Primer pump and universal joint, removal and installation.



A



B

A-Line disconnect

MSC 4210-205-12/60
B-Assembly removal

Figure 60. Hose reel, removal and installation.

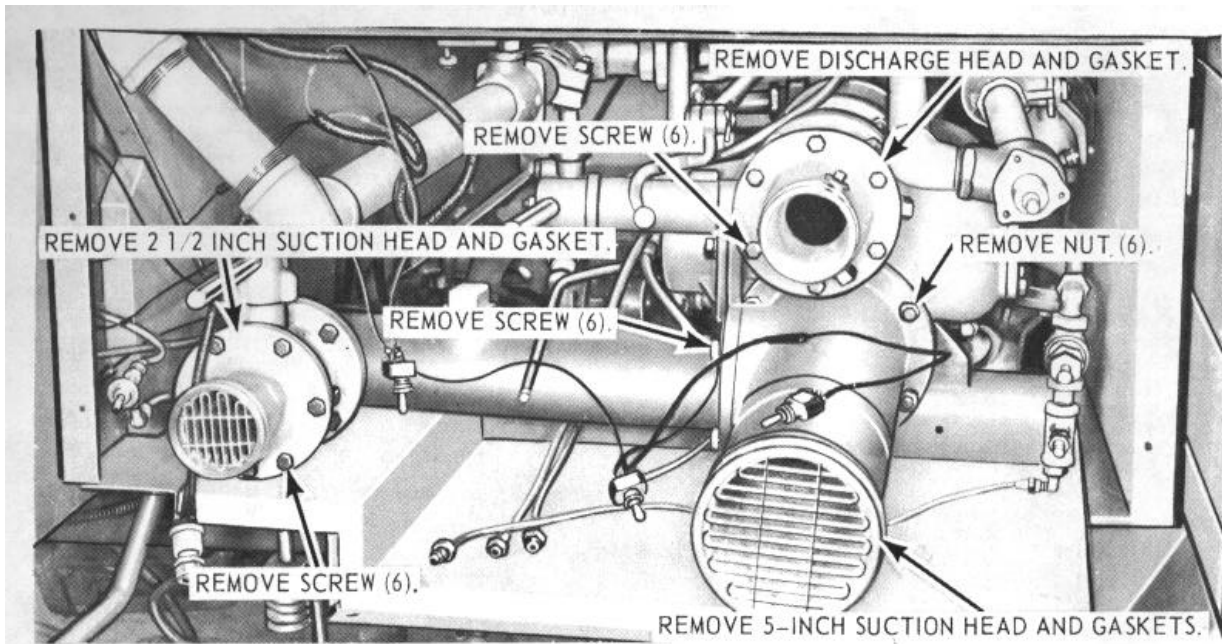

A

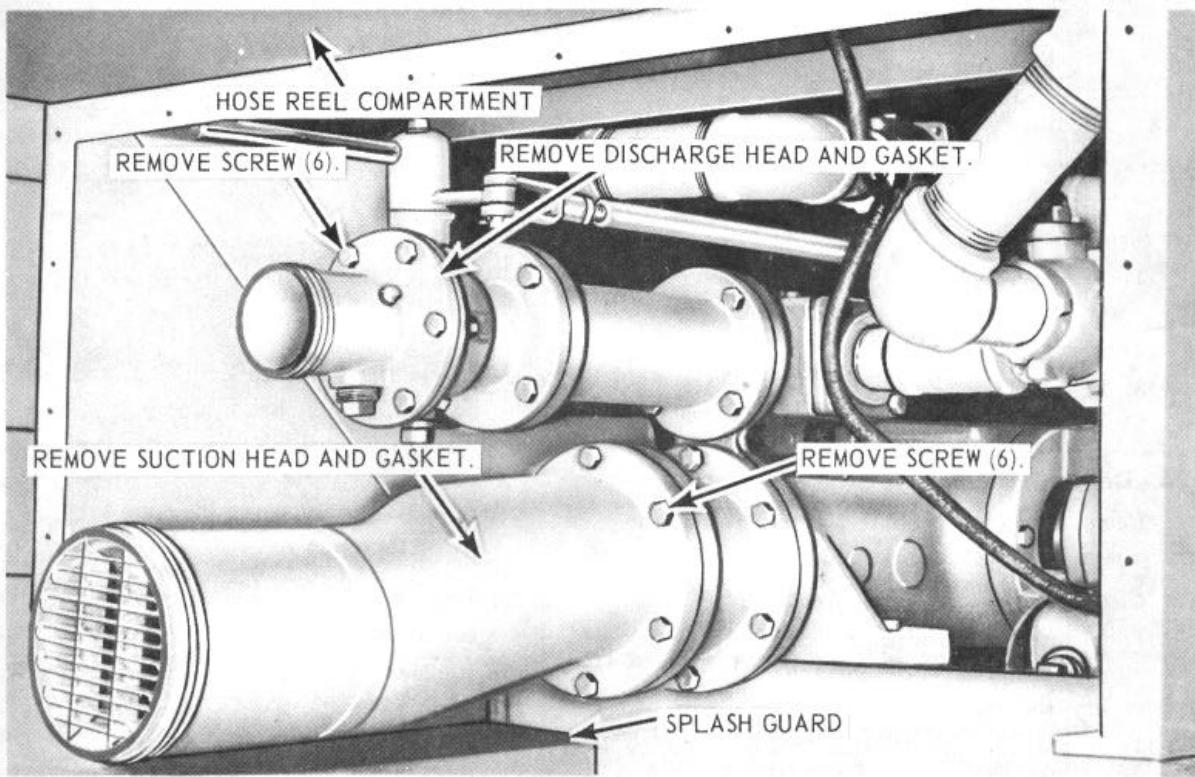

B

A-Left side

MSC 4210-205-12/61

B -Right side

Figure 61. Suction and discharge heads and screens, removal and installation.

- (2) Inspect all parts for damaged or defective condition.
- (3) Replace or repair damaged or defective parts as necessary.

c. Installation.

- (1) Refer to figure 59, and install the primer pump on the water pump manifold.
- (2) Install the primer pump motor and solenoid relay (para. 105).

123. Hose Reel

a. Removal.

- (1) Remove the hose reel motor solenoid (para. 103).
- (2) Remove the hose reel motor (para. 104).
- (3) Refer to figure 60, and remove the hose reel from the hose reel and pump compartment.

b. Cleaning, Inspection, and Repair.

- (1) Clean all parts with a clean cloth dampened in an approved cleaning solvent, and dry thoroughly.
- (2) Inspect all parts for damaged or defective condition.
- (3) Replace or repair damaged or defective parts as necessary.

c. Installation.

- (1) Refer to figure 60, and install the hose reel on the hose reel and pump compartment.
- (2) Install the hose reel motor (para. 104).
- (3) Install the hose reel motor solenoid (para. 103).

124. Drive Chain

a. Removal. Refer to figure 50, and remove the drive chain from the hose reel and motor.

b. Cleaning, Inspection, and Repair.

- (1) Clean all parts with a clean cloth dampened in an approved cleaning solvent, and dry thoroughly.
- (2) Inspect all parts for damaged or defective condition.
- (3) Replace or repair damaged or defective parts as necessary.

c. Installation. Refer to figure 50, and install the drive chain on the hose reel and motor.

125. Suction and Discharge Heads and Screens

a. Removal.

- (1) Remove the instrument panels (paras. 113 and 114).
- (2) Refer to figure 61, and remove the suction heads and screens from the suction and discharge lines.

b. Cleaning, Inspection, and Repair.

- (1) Clean all parts with an approved cleaning solvent, and dry thoroughly.
- (2) Inspect all parts for damaged or defective condition.
- (3) Replace or repair damaged or defective parts as necessary.

c. Installation.

- (1) Refer to figure 61, and install the suction and discharge heads and screens on the suction and discharge lines.
- (2) Install the instrument panels (paras. 113 and 114).

126. Pump Clutch Linkage

a. Removal.

- (1) Remove the tool box (TM 9-2320-235-20).
- (2) Refer to figure 62, and remove the pump clutch linkage from the clutch and transfer case.

b. Disassembly. Refer to figure 63, and disassemble the pump clutch linkage.

c. Cleaning, Inspection, and Repair.

- (1) Clean all parts with a clean cloth dampened in an approved cleaning solvent, and dry thoroughly.
- (2) Inspect all parts for damaged or defective condition.
- (3) Replace or repair damaged or defective parts.

d. Reassembly. Refer to figure 63, and reassemble the pump clutch linkage in the reverse order.

e. Installation. Refer to figure 63, and install the pump clutch linkage on the clutch and transfer case.

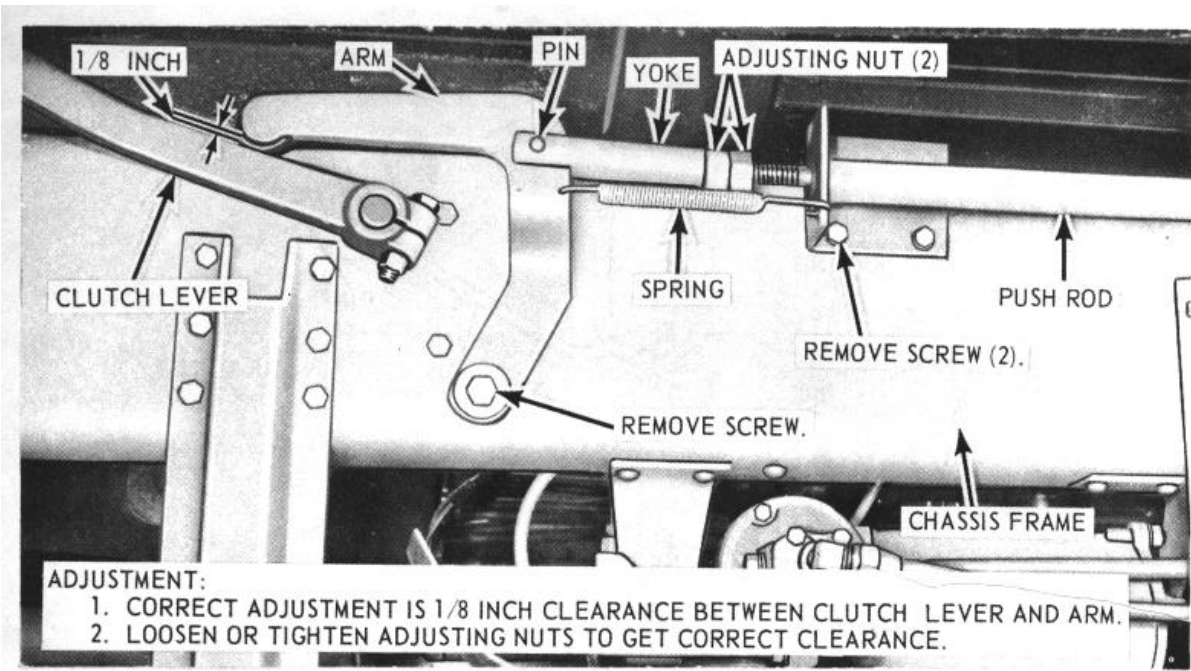

A

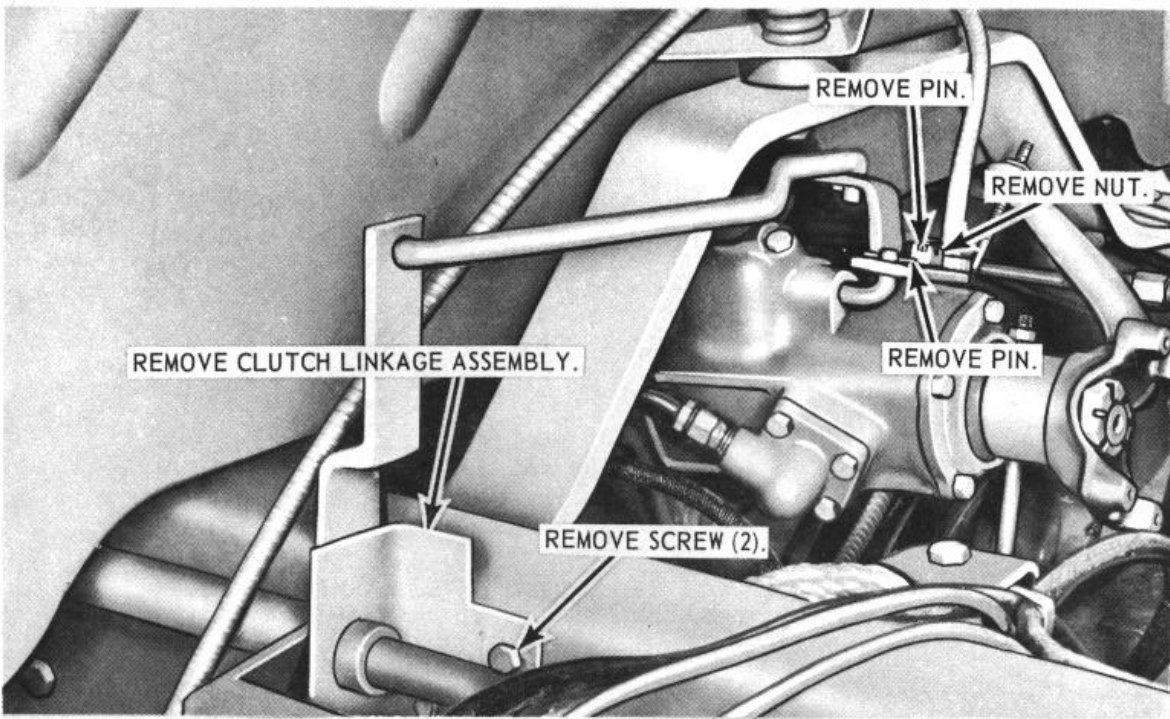

B

MSC 4210-205-12/62

A-Front removal points

B-Rear removal points

Figure 62. Pump clutch linkage, removal, installation and adjustment.

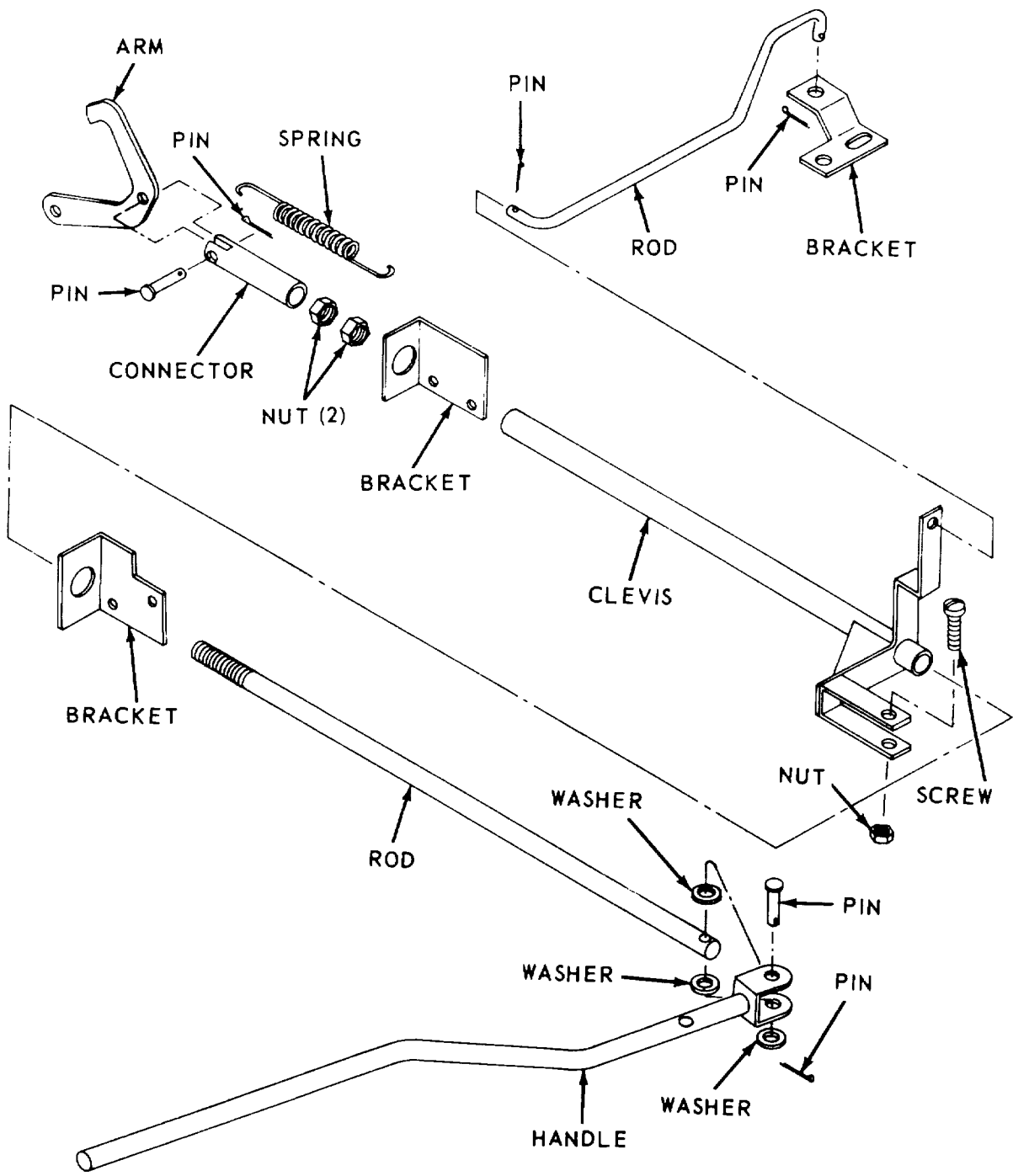

MSC 4210-205-12/63

Figure 63. Pump clutch linkage, exploded view.

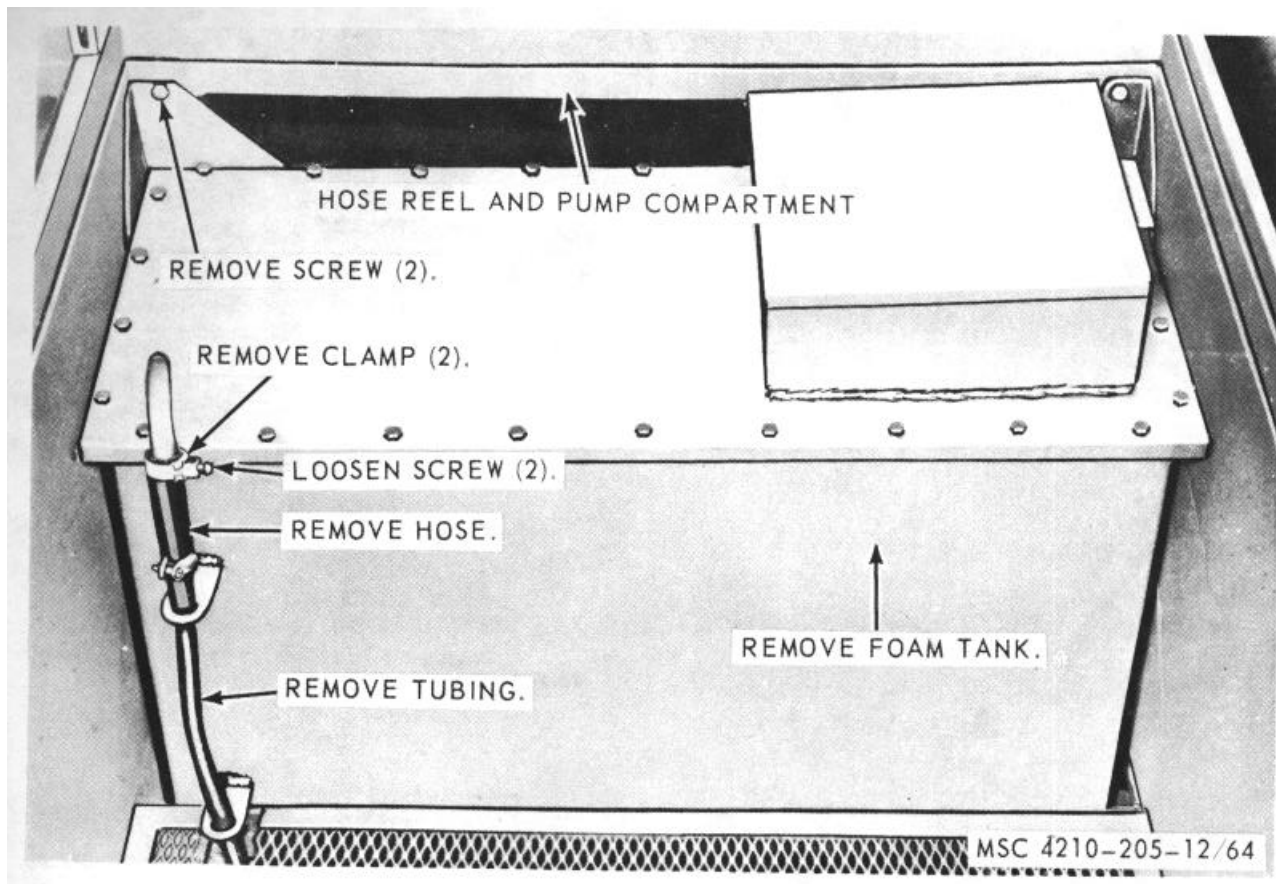

Figure 64. Foam tank, vent hose, and foam tank, removal and installation.

f. *Adjustment.*

- (1) Refer to figure 62, and adjust the pump clutch linkage.
- (2) Install the tool box (TM 9-2320-235-20).

c. *Installation.*

- (1) Refer to figure 64, and install the foam tank and vent hose on the compartment.
- (2) Fill the foam tank (para. 18).

127. Foam Tank Strainer, Foam Tank and Vent Hose

a. *Removal.*

- (1) Drain the foam tank (para. 20).
- (2) Refer to figure 64, and remove the foam tank and vent hose from the compartment.

b. *Cleaning, Inspection, and Repair.*

- (1) Clean all parts with a clean cloth dampened in an approved cleaning solvent, and dry thoroughly.
- (2) Inspect all parts for damaged or defective condition.
- (3) Replace or repair damaged or defective parts as necessary.

128. Water Tank and Lines

a. *Removal*

- (1) Drain the water tank (para. 20).
- (2) Remove the foam tank (para. 127).
- (3) Remove the ladder support assemblies (para. 127).
- (4) Refer to figure 65, and remove the water tank from the special purpose body.

b. *Cleaning, Inspection, and Repair.*

- (1) Clean all parts with an approved cleaning solvent, and dry thoroughly.
- (2) Inspect all parts for damaged or defective condition.
- (3) Replace or repair damaged or defective parts.

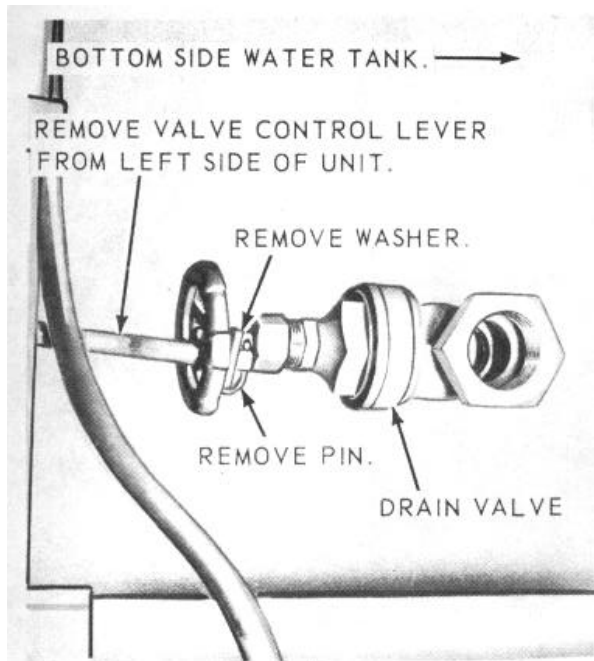

A

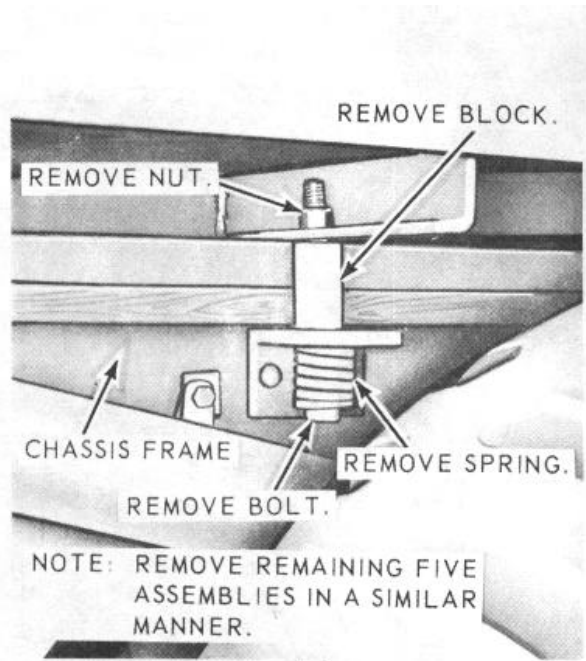

B

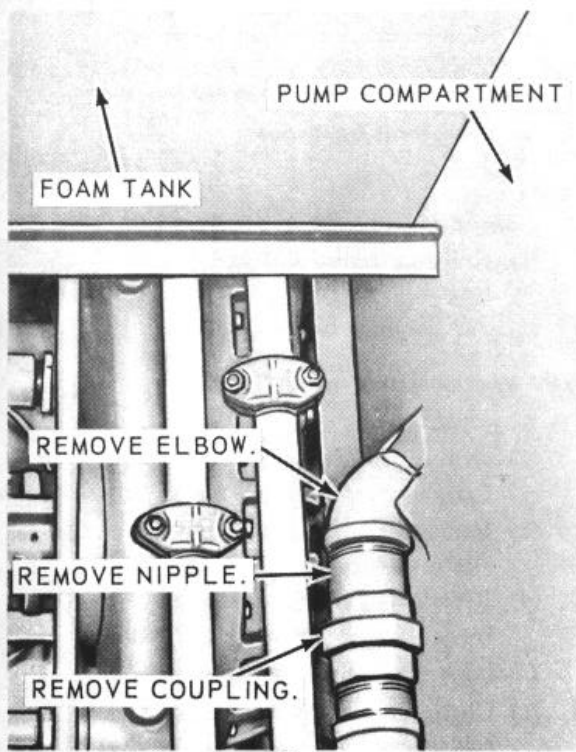

C

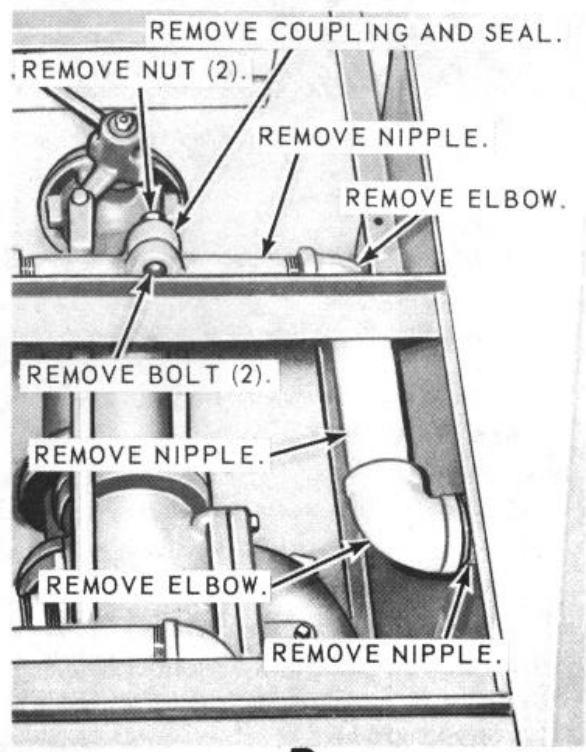

D

MSC 4210-205-12/65 ①

A-Control lever removal

B-Through bolt removal

C-Line removal

D-Line removal

Figure 65. Water tank and lines, removal and installation.

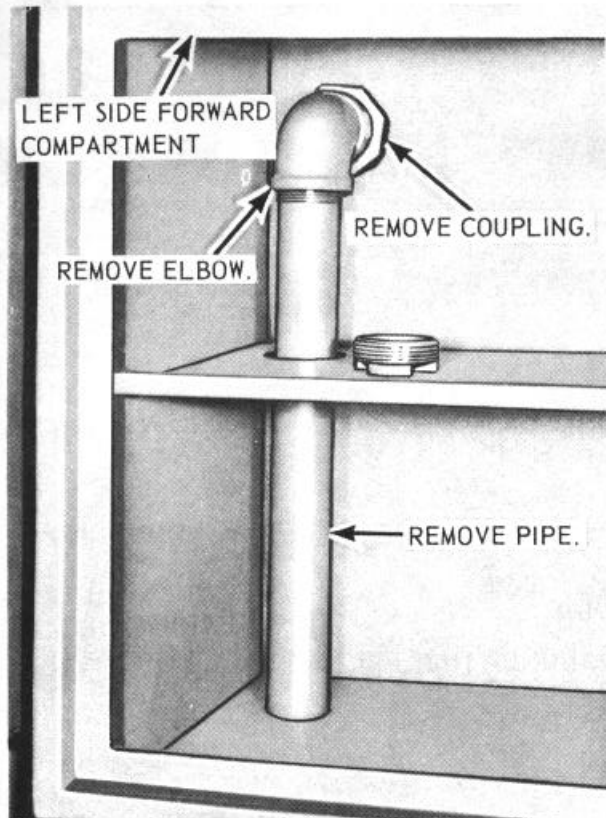

E

E-Vent line removal

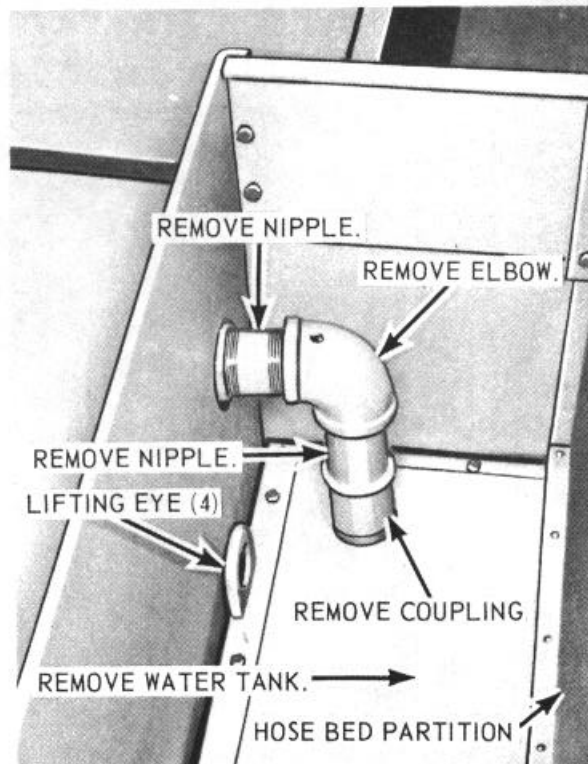

F

F-Tank removal

MSC 4210-205-12/65 (2)

Figure 65-Continued.

c. Installation.

- (1) Refer to figure 65, and install the water tank and lines on the special purpose body.
- (2) Install the ladder support assemblies (para. 63).
- (3) Install the foam tank (para. 127).
- (4) Fill the water tank (para. 18).

129. Pump Drive Universal Joint

a. Removal. Refer to figure 59, and remove the pump drive universal joint from the pump and transfer case.

b. Disassembly. Refer to figure 66, and disassemble the pump drive universal joint.

c. Cleaning, Inspection, and Repair.

(1) Clean all parts with a clean cloth dampened in an approved cleaning solvent, and dry thoroughly.

(2) Inspect all parts for damaged or defective condition.

(3) Replace or repair damaged or defective parts.

d. Reassembly. Refer to figure 66, and reassemble the pump drive universal joint in the reverse order.

e. Installation. Refer to figure 59, and install the pump drive universal joint on the pump and transfer case.

130. Drain Valve and Tubing

a. Removal

- (1) Drain the lines (para. 20)..

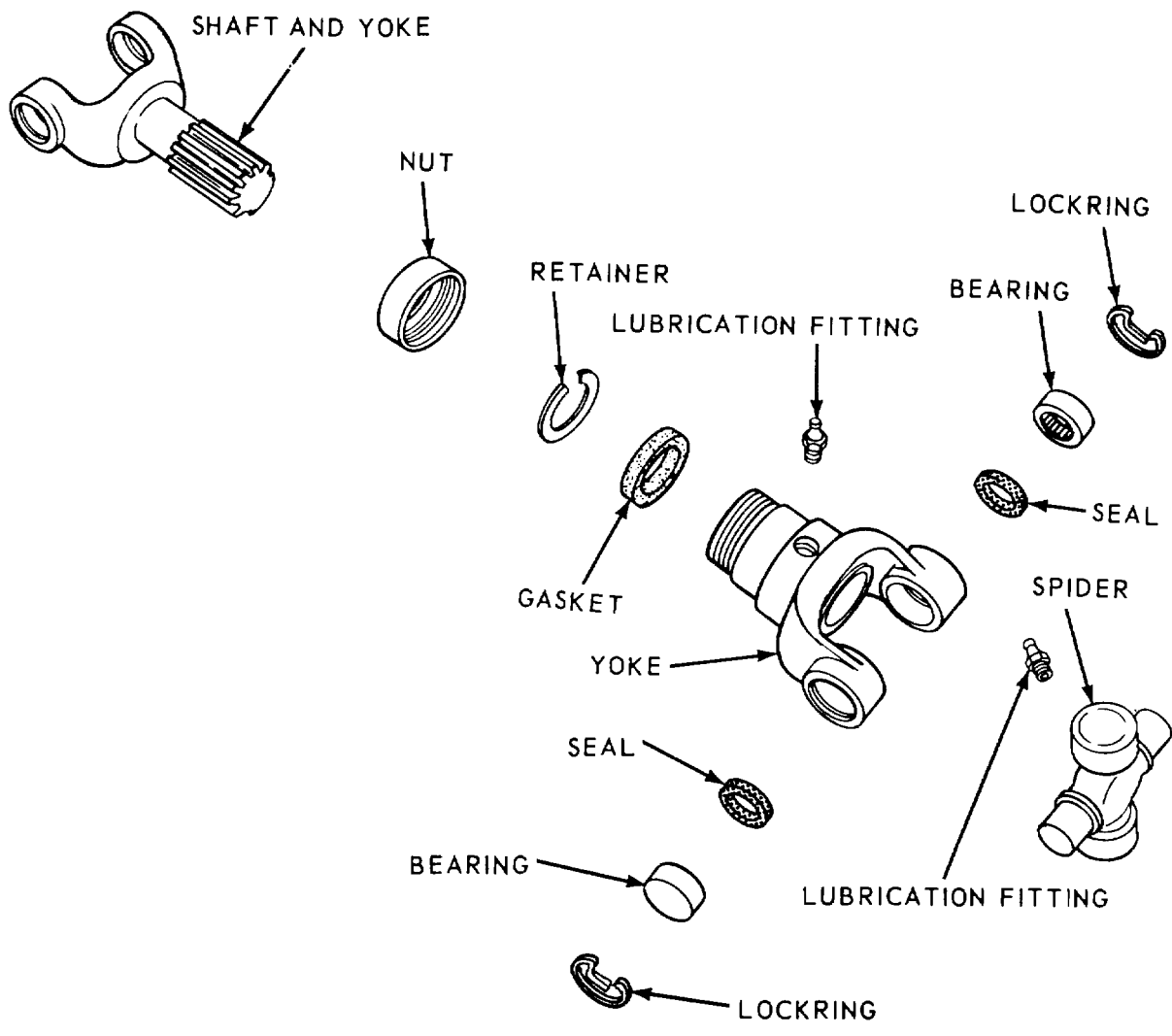

MSC 4210-205-12/66

Figure 66. Pump drive universal joint, exploded view.

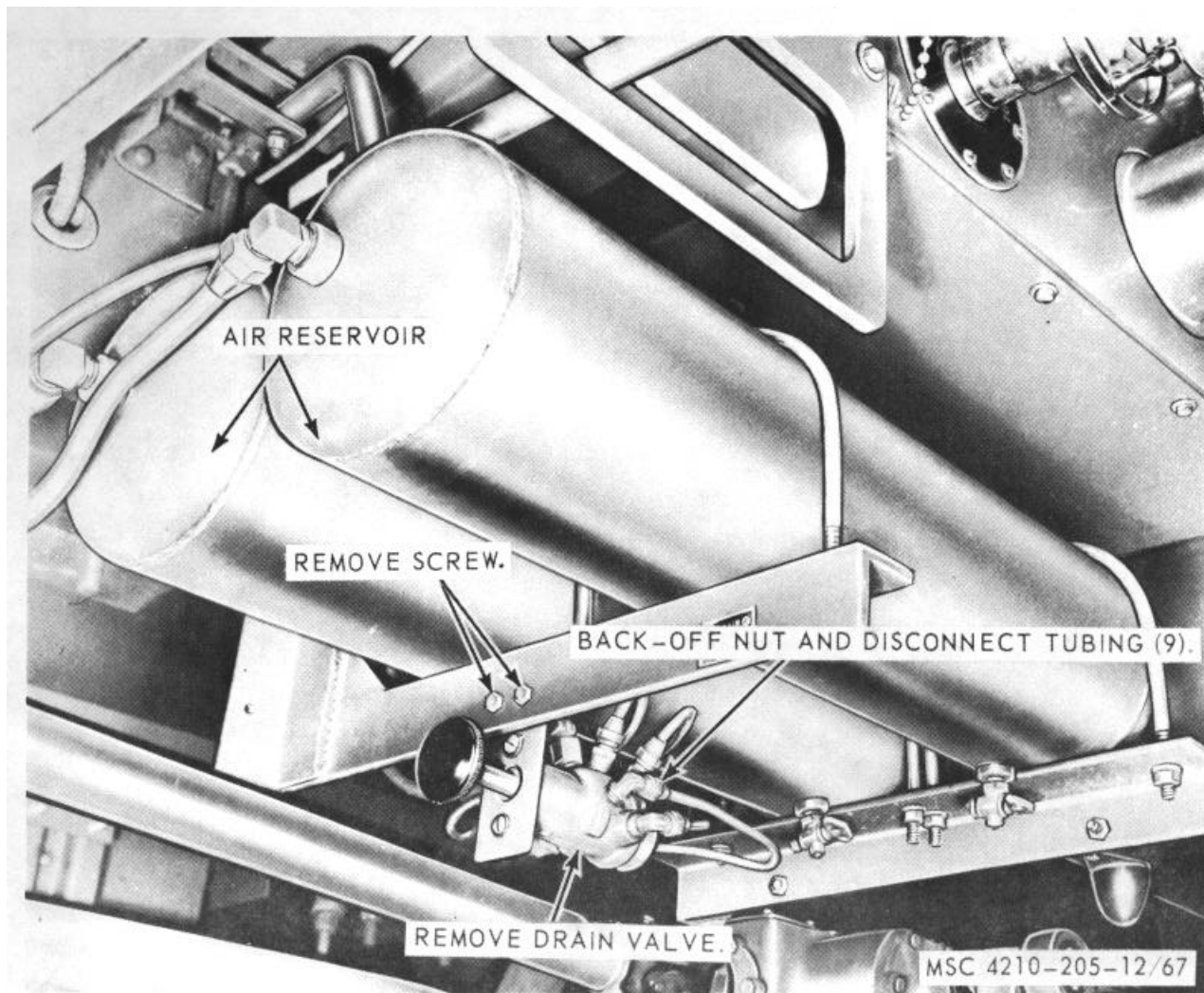

Figure 67. Drain valve and tubing, removal and installation.

(2) Refer to figure 67, and remove the drain valve and tubing from the valves, lines, and bracket.

b. Cleaning, Inspection, and Repair

(1) Clean all parts with a clean cloth dampened in an approved cleaning solvent, and dry thoroughly.

(2) Inspect all parts for damaged or defective condition.

(3) Replace or repair damaged or defective parts as necessary.

c. Installation. Refer to figure 67, and install the drain valves and tubing on the valves, lines, and bracket.

131. Heat Exchanger and Tubing

a. Removal. Refer to figure 68, and remove the cooler manifold and tubing from the engine compartment.

b. Cleaning, Inspection, and Repair.

(1) Clean all parts with a clean cloth dampened in an approved cleaning solvent, and dry thoroughly.

(2) Inspect all parts for damaged or defective condition.

(3) Replace or repair damaged or defective parts as necessary.

c. Installation. Refer to figure 68, and install the heat exchanger and tubing on the engine compartment.

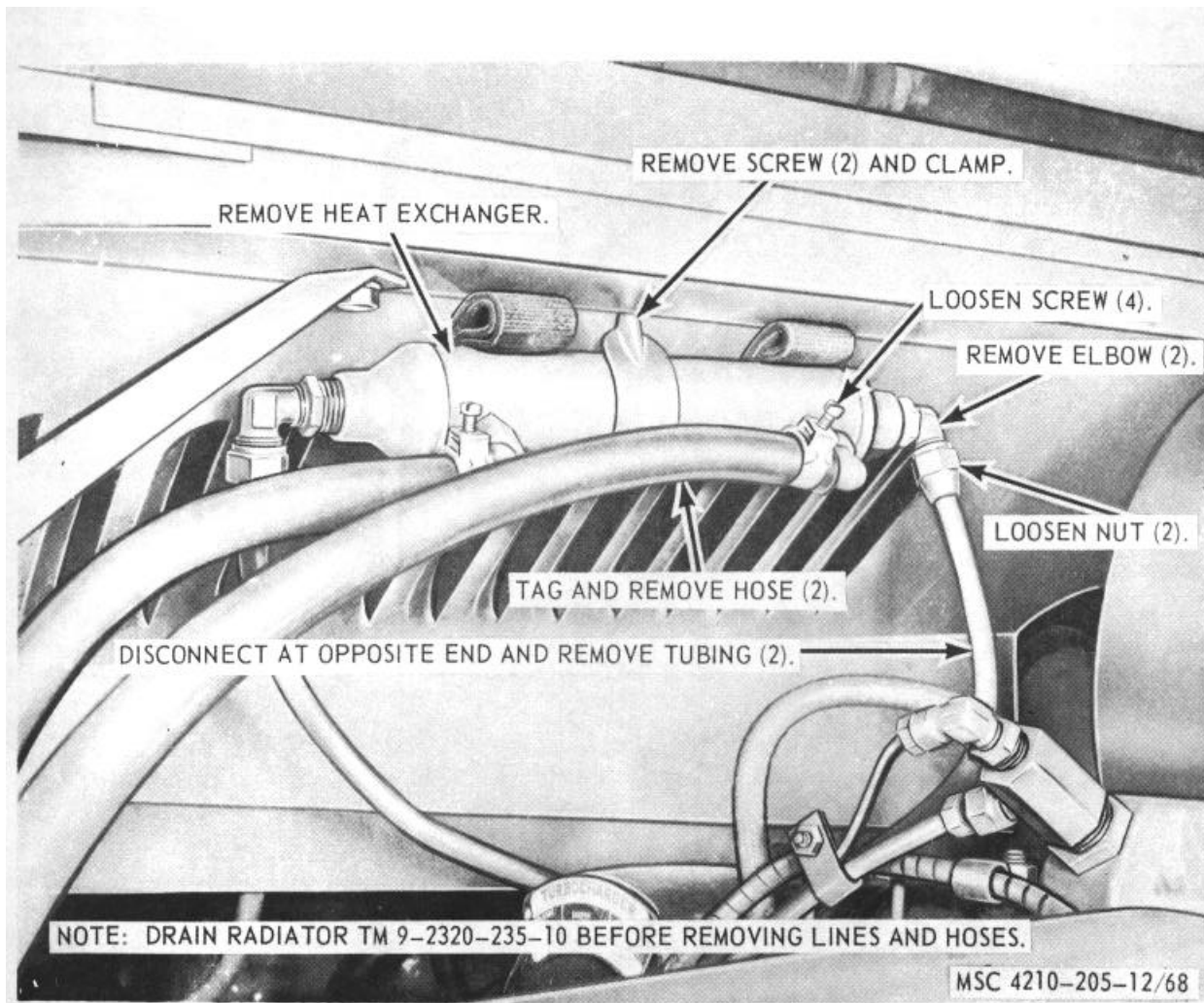

Figure 68. Heat exchanger and tubing, removal and installation.

132. Relief Valve Control

a. *Removal.* Refer to figure 55, and remove the relief valve control from the left side control panel.

b. *Cleaning, Inspection, and Repair.*

(1) Clean all parts with an approved cleaning solvent, and dry thoroughly.

(2) Inspect all parts for damaged or defective condition.

(3) Replace or repair damaged or defective parts as necessary.

c. *Installation.* Refer to figure 55, and install the relief valve control on the left side control panel.

133. Water Pump Packing

Refer to figure 69, and adjust the water pump packing.

ADJUSTMENT:

1. MAKE SURE SLEEVE SCREW IS TIGHT.
2. LOOSEN PACKING GLAND SCREW.
3. TURN PACKING GLAND NUT CLOCKWISE TO TIGHTEN COUNTERCLOCKWISE TO LOOSEN PACKING.
4. TIGHTEN PACKING GLAND SCREW AND LOCK IN PLACE WITH LOCKNUT.

NOTE: ADJUSTMENT IS NECESSARY ONLY WHEN AIR LEAKS IN WHEN WORKING FROM DRAFT OR WATER LEAKS OUT WHEN WORKING FROM HYDRANT.

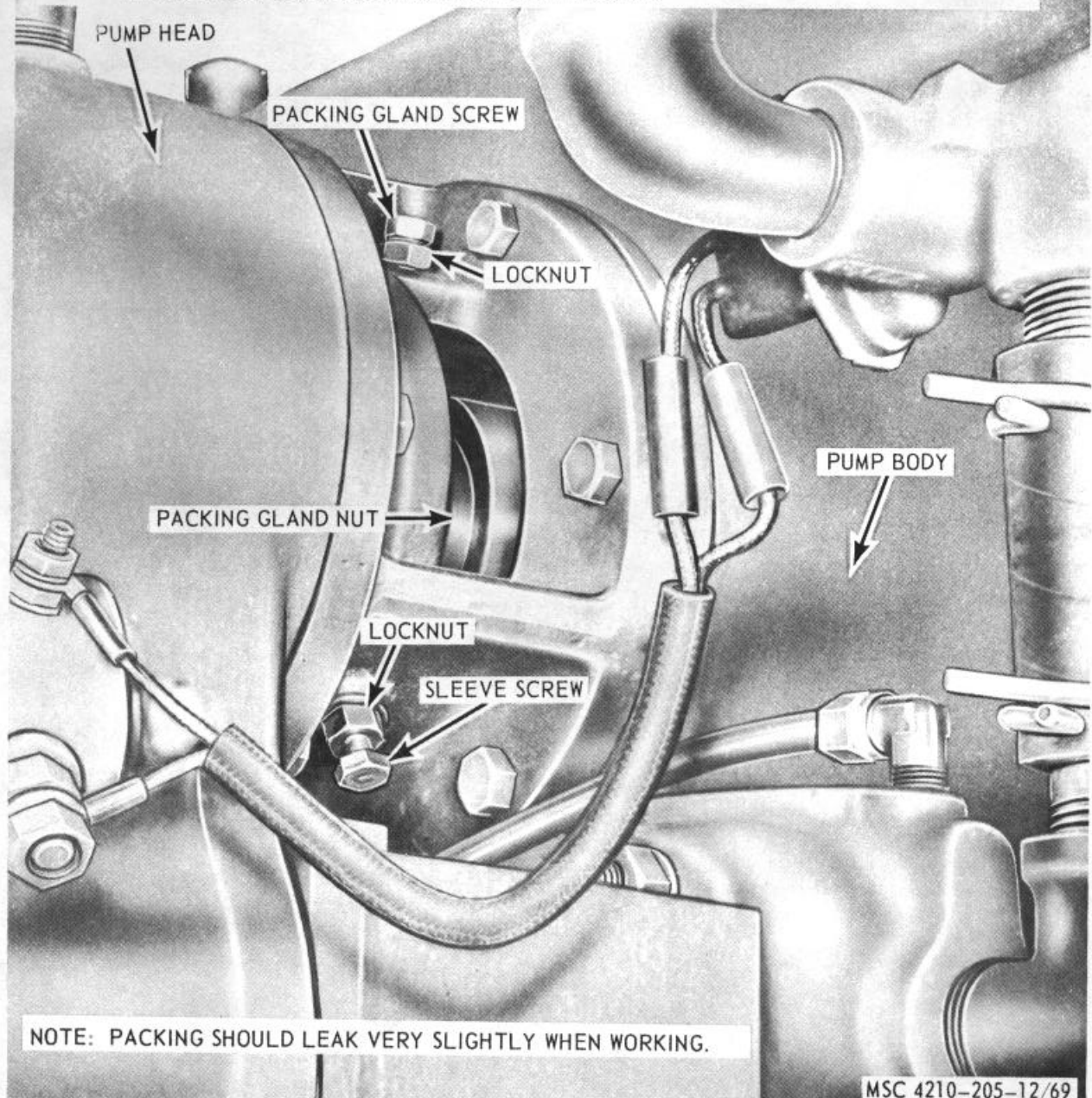

Figure 69. Water pump packing adjustment.

Section XIV. LUBRICATION SYSTEM

134. General

The lubrication system consists of an oil tank and lines that supply lubrication to the vacuum priming pump.

135. Oil Tank and Lines

a. Removal.

(1) Disconnect the oil line at the priming pump (para. 122).

(2) Refer to figure 70, and remove the oil tank and lines from the cab and priming pump).

b. Cleaning, Inspection, and Repair.

(1) Clean all parts with a clean cloth dampened in an approved cleaning solvent, and dry thoroughly.

(2) Inspect all parts for damaged or defective condition.

(3) Replace or repair damaged or defective parts as necessary.

c. Installation.

(1) Refer to figure 70, and install the oil tank and lines on the cab and priming pump.

(2) Connect the oil line at the priming pump (para. 122).

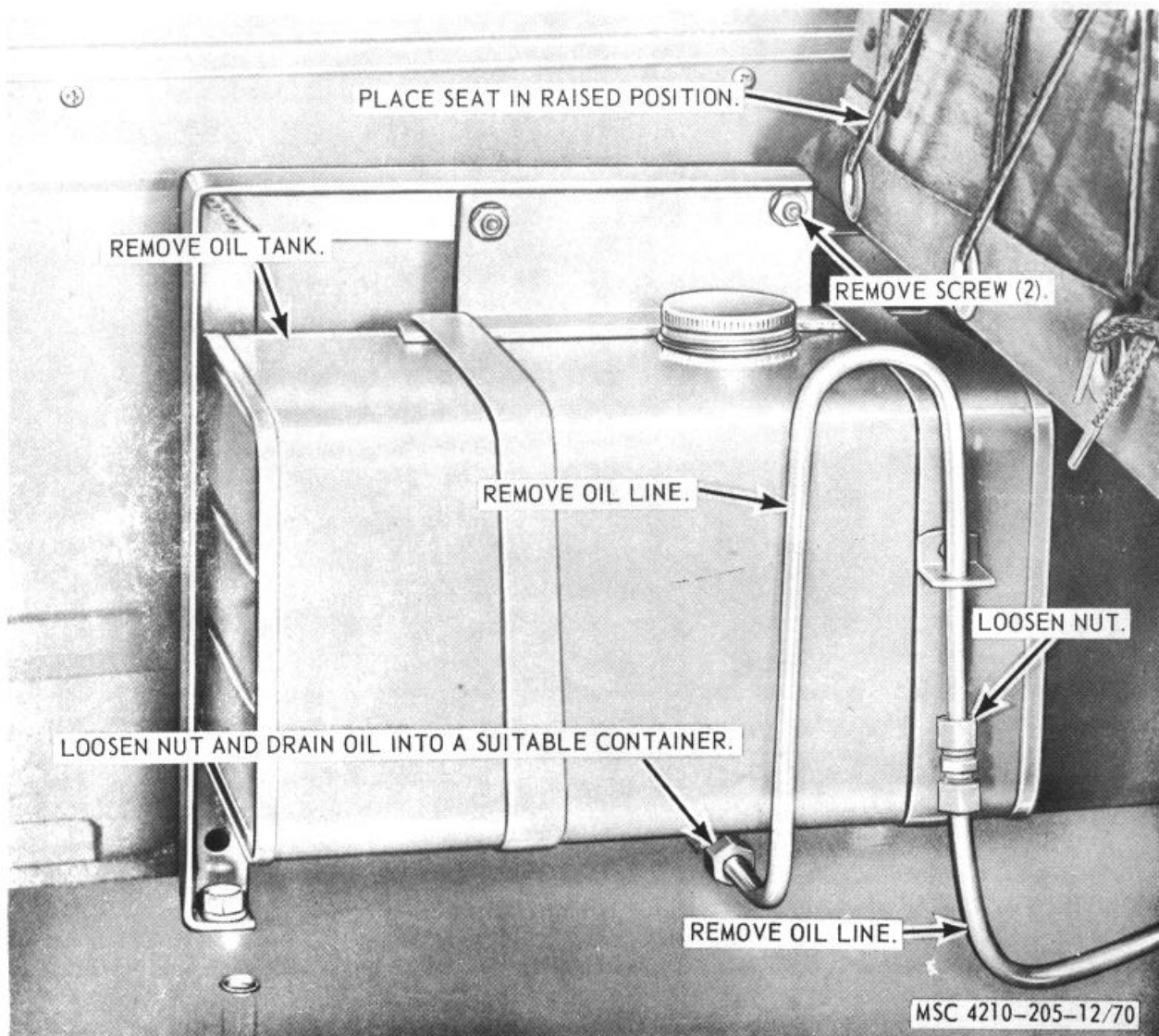

Figure 70. Oil tank and lines, removal and installation.

CHAPTER 4

DEMOLITION OF FIRE TRUCK TO PREVENT ENEMY USE

136. General

When capture or abandonment of the fire truck to an enemy is imminent, the responsible unit commander must make the decision either to destroy the equipment or to render it inoperative. Based on this decision, orders are issued which cover the desired extent of destruction. Whatever method of demolition is employed, it is essential to destroy the same vital parts of all fire trucks, and all corresponding repair parts.

137. Demolition to Render Equipment Inoperative

a. *Mechanical Means.* Use sledge hammers, crowbars, picks, axes, or other heavy tools that may be available, together with the tools normally included with the fire truck, to destroy the following:

- (1) Engine accessories.
- (2) Fuel tank.
- (3) Controls and instruments.

Note. The above steps are minimum requirements for this method.

b. *Misuse.* Perform the following steps to render the fire truck inoperative.

- (1) Drain the engine crankcase.
- (2) Throw sand, mud, and other foreign substances into the oil filter openings and engine crankcase.
- (3) Drain the cooling system.
- (4) Cut the drive belts.
- (5) Drain the water pump transmission.
- (6) Drain the primer pump oil tank.
- (7) Throw dirt or sand into the radiator and fuel tank.
- (8) Operate the engine and fire pump at full speed until failure occurs.

Note. The above steps are minimum requirements for this method.

138. Demolition by Explosives or Weapons Fire

a. *Explosives.* Place as many of the charges shown on figure 71 as the situation permits and detonate them simultaneously with a detonating cord and suitable detonator.

- (1) One 1/2-pound charge between the generator and cylinder block.
- (2) One 1/2-pound charge between the starting motor and flywheel housing.
- (3) One 1/2-pound charge between fire pump and primer pump.
- (4) One 1/2-pound charge on each hose reel.
- (5) One 1/2-pound charge on water tank.

b. *Weapons Fire.* Fire on the fire truck with the heaviest suitable weapons available.

139. Other Demolition Methods

a. *Scattering and Concealment.* Remove all easily accessible parts, such as fuel pump, fuel filters, oil filter, air cleaner, and batteries. Scatter them through dense foliage, bury them in the ground, or throw them in a lake, stream, or other body of water.

b. *Burning.* Pack rags, clothing, or canvas around the engine, pump and control panels. Saturate this packing with gasoline, oil, or diesel fuel and ignite.

c. *Submersion.* Totally submerge the fire truck in a body of water, if possible, to provide some water damage and concealment. Salt water will do greater damage to metal parts than fresh water.

140. Training

All operators should receive thorough training in the destruction of the fire truck (FM 5-25). Simulated destruction, using all of the methods listed above, should be included in the operator training, that demolition operations are usually necessitated by

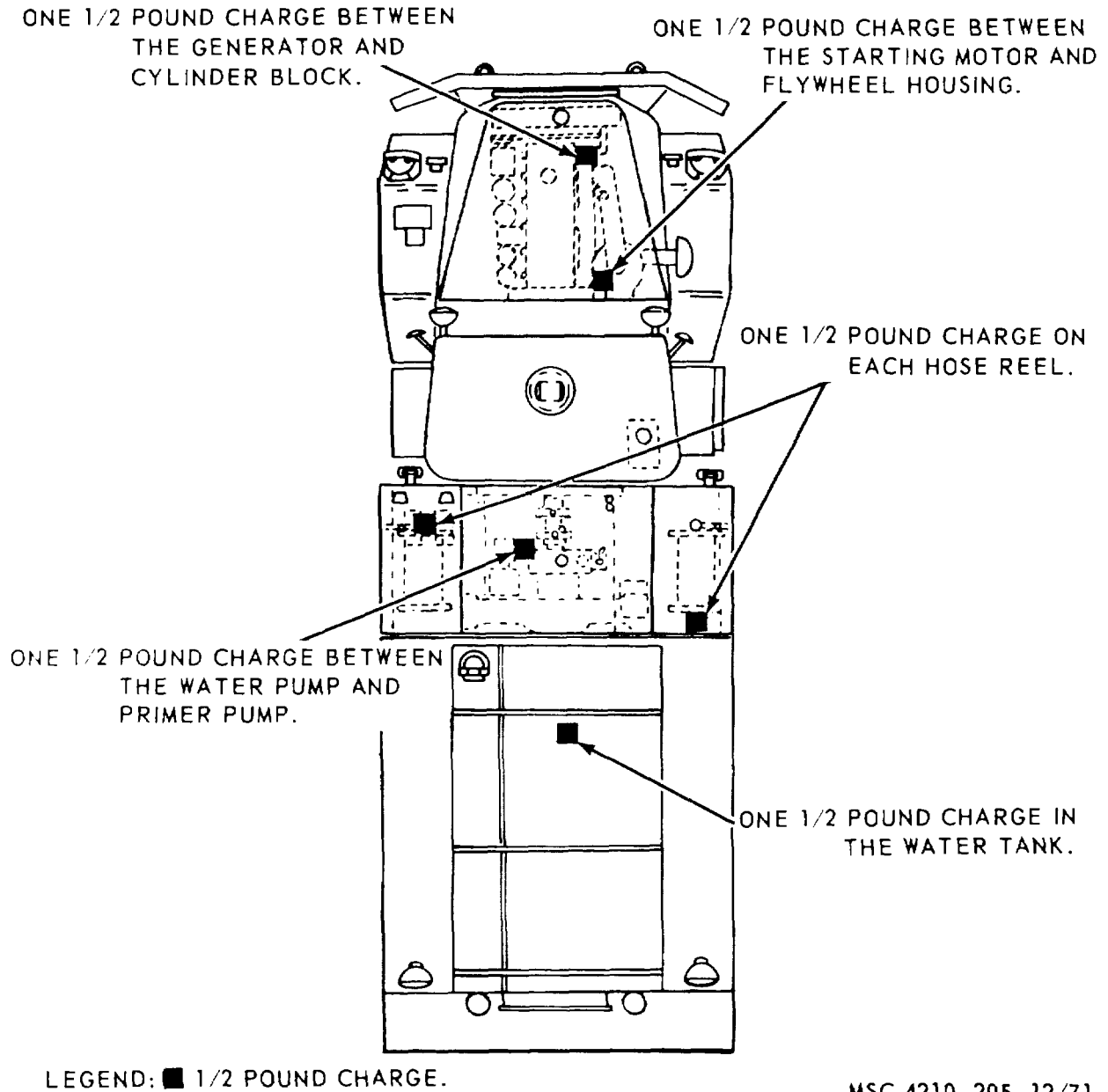

Figure 71. Placement of charges.

Critical situations when time available for carrying out destruction is limited. For this reason, it is necessary that operators be thoroughly familiar with all methods of

destruction of equipment, and be able to carry out demolition instructions without reference to this or any other manual.

CHAPTER 5

SHIPMENT AND LIMITED STORAGE

Section I. SHIPMENT WITHIN ZONE OF INTERIOR

141. Preparation of Equipment for Shipment

a. *General.* Detailed instructions for the preparation of the fire truck for domestic shipment are outlined within this paragraph. Preservation will be accomplished in sequence that will not require the operation of previously preserved components.

b. *Inspection.* Inspect the fire truck for any unusual conditions such as damage, rusting, deterioration, accumulation of water, and missing components. Inspect in accordance with steps outlined in tile quarterly preventive maintenance services.

c. *Cleaning and Drying.* Before applying any preservative or paint, thoroughly clean all exterior surfaces by an approved cleaning process. After cleaning and before applying any preservatives or paint, dry thoroughly all surfaces. Approved methods of cleaning and drying are described in TM 38-230.

d. *Painting.* Paint all surfaces where the paint has been removed or damaged. Refer to TB ENG 60 for detailed cleaning and painting instructions.

e. *Depreservation Guide.* Annotate depreservation instructions on DA Form 2258 (Depreservation Guide of Engineer Equipment) concurrently with the preservation of the fire truck. Any additional requirements will be outlined in blocks 27 through 33 of DA Form 2258. Place completed DA Form 2258 in a waterproof envelope marked "Depreservation Guide" and secure it in a conspicuous location on or near the operator's controls.

f. *Lubrication System.* Drain the water pump crankcase and primer pump oil tank and fill with preservative oil. Attach tags to indicate that crankcase and oil tank are filled with preservative oil.

g. *Sealing of Openings.* Seal all openings that will permit the direct entry of water into the interior of the engine or other components of the fire truck, with tape conforming to Type III, Class I of Specification PPP-T-60.

h. *Exterior Surfaces.* Coat exposed, machined, ferrous metal surfaces with preservative (P-6) conforming with Specification MIL-C-11796, Class 3. If preservative is not available, GAA-GREASE, Automotive and Artillery, may be used.

i. *Marking.* Mark fire truck in accordance with requirements of Military Standard MIL-STD-129.

j. *Pumps.* Spray interior of pumps with P-3 preservative oil conforming to MIL-C-16173, grade 3. Seal openings that will permit the direct entry of water with Type III, Class I, waterproof pressure-sensitive adhesive tape, PPP--T-60.

k. *Disassembly, Disassembled Parts, Basic Issue Items.*

(1) Disassembly will be limited to the removal of parts and projecting components that tend to increase the overall profile of the equipment and that which is subject to pilferage.

(2) Disassembled items will be packed with the publications in the tool box if possible. Otherwise, items will be packed in a suitable container and secure to the equipment to prevent loss or pilferage.

l. *Hose and Couplings.* Recoil on hose reels. Shroud exposed hose not protected by storage facilities with waterproof wrapping paper (UU-P-271).

142. Loading Equipment for Shipment

a. Use a suitable lifting device, and hoist the fire truck on the carrier. Refer to paragraph 6.

Note. Spreader bars should be used to keep hoist cables from coming in contact with the fire truck.

b. Block and secure the fire truck to the flatcar as illustrated on figure 4.

c. Apply handbrake and place transmission in neutral position.

Section II. LIMITED STORAGE

143. Preparation of Equipment for Storage

a. *General.* Detailed instructions for preserving and maintaining equipment in limited storage are outlined in this paragraph. Limited storage is defined as storage not to exceed 6 months. Refer to AR 743-505.

b. *Inspection.* Refer to paragraph 141b.

c. *Cleaning and Drying.* Refer to paragraph 141c.

d. *Painting.* Refer to paragraph 141d.

e. *Depreservation Guide.* Refer to paragraph 141e.

f. *Lubrication. System.* Refer to paragraph 141f.

g. *Sealing of Openings.* Refer to paragraph 141g.

h. *Exterior Surfaces.* Refer to paragraph 141h.

i. *Marking.* Refer to paragraph 141i.

j. *Pumps.* Refer to paragraph 141j.

k. *Disassembly, Disassembled Parts, Basic Issue Items.* Refer to paragraph 141k.

l. *Hose and Couplings.* Refer to paragraph 141l.

m. *Weatherproofing.* When suitable shelter is not available, select a firm, level, storage location protected from prevailing winds. Position the fire truck on heavy planking or other solid surfaces. Cover the fire truck with a tarpaulin or other suitable waterproof covering and tiedown securely.

144. Inspection and Maintenance of Equipment in Storage

a. *Inspection.* When fire truck has been placed in storage, all scheduled preventive maintenance services, including inspection, shall be suspended and preventive maintenance inspection shall be performed as specified herein. Refer to AR 743-505.

b. *Worksheet and Preventive Maintenance.* DA Form 2258 (Depreservation Guide of Engineer Equipment) and applicable forms listed in TM 38-750 will be prepared for each major item of equipment when initially placed in limited storage and every 90 days thereafter. Perform required maintenance promptly to make sure equipment is mechanically sound and ready for immediate use.

c. *Exercising.* Service equipment in limited storage every 90 days in accordance with paragraph 18. Operate equipment long enough to bring it up to operating temperature and insure complete lubrication of all bearings, gears, and the like. Represerve equipment after operation.

APPENDIX I
REFERENCES

1. Dictionaries of Terms and Abbreviations

AR 320-5 Dictionary of United States Army Terms.
AR 320-50 Authorized Abbreviations and Brevity Codes.

2. Fire Protection

TM 5-687 Repairs and Utilities: Fire Protection Equipment and Appliances; Inspections, Operations, and Preventive Maintenance.
TM 9-1799 Ordnance Maintenance: Fire Extinguishers.

3. Lubrication

LO 5-4210-205-12 Truck, Fire Fighting: Powered Pumper: Foam and Water 500 G.P.M. Cap.; Centrifugal Pump, Power Take Off Driven; 400 Gal. Water Tank, 40 Gal. Foam Chemical Tank (Ward LaFrance Model M44A1WLF).

4. Painting and Preservation

TB ENG 60 Preservation and Painting of Serviceable Corps of Engineers Equipment.

5. Preventive Maintenance

TM 9-207 Operation and Maintenance of Ordnance Materiel in Extreme Cold Weather (0° to -65° F.).
TM 9-6140-200-15 Storage Batteries, Lead-Acid Type.
TM 38-750 The Army Equipment Records System and Procedures.

6. Publication Indexes

DA Pam 108 1 Index of Army Motion Pictures, Filmstrips, Slides, Tapes, and Phono-Recordings.
DA Pam 310-1 Index of Administrative Publications..
DA Pam 310-2 Index of Blank Forms.
DA Pam 310-3 Index of Doctrinal Training and Organizational Publications.
DA Pam 310-4 Index of Technical Annuals, Technical Bulletins, Supply Manuals (types 4, 6, 7, 8, and 9). Supply Bulletins, Lubrication Orders, and Modification Work Orders.
DA Pam 310 5 Index of Graphic Training Aids and Devices.
DA Pam 310-25 Index of Supply Manuals - Engineer Type Items.

7. Radio Interference Suppression

TM 11-483 Ratio Interference Suppression.

8. Shipment and Limited Storage

AR 743-505 Limited Storage of Engineers Mechanical Equipment.
TM 38-230 Preservation, Packaging, and Packing of Military Supplies and Equipment.

9. Supply Publications

SM 10-C9100-SL

Petroleum, Petroleum-Base Products, and Related Materiel.

10. Training Aids

FM 5-25

Explosives and Demolitions.

FM 21-5

Military Training.

FM 21-6

Techniques of Military Instructions.

FM' 21-30

Military Symbols.

APPENDIX II MAINTENANCE ALLOCATION

Section I. INTRODUCTION

1. General

This appendix contains explanations of all maintenance and repair functions authorized for the various levels. Section II contains the maintenance allocation chart.

2. Maintenance

Maintenance is any action taken to keep materiel in a serviceable condition or to restore it to serviceability when it is unserviceable. Maintenance of materiel includes the following:

a. Service. To clean, preserve, and replenish fuel and lubricants.

b. Adjust. To regulate periodically to prevent malfunction.

c. Inspect. To verify serviceability and detect incipient electrical or mechanical failure by scrutiny.

d. Test. To verify serviceability and detect incipient electrical or mechanical failure by use of special equipment such as gages, meters, and the like.

e. Replace. To substitute serviceable assemblies, subassemblies, and parts for unserviceable components.

f. Repair. To restore an item to serviceable condition through correction of a specific failure or unserviceable condition. This function includes, but is not limited to, inspecting, cleaning, preserving, adjusting, replacing, welding, riveting, and straightening.

g. Align. To adjust two or more components of an electrical system so that their functions are properly synchronized.

h. Calibrate. To determine, check, or rectify the graduation of an instrument, weapon, or weapons system, or components of a weapons system.

i. Overhaul. To restore an item to completely serviceable condition as prescribed by serviceability standards developed. This is accomplished through employment of the technique of "Inspect and Repair Only as Necessary" (IROAN). Maximum utilization of diagnostic and test equipment is combined with minimum disassembly of the item during the overhaul process.

3. Explanation of Columns

a. Functional Group. The functional group is a numerical group set up on a functional basis. The applicable functional grouping indexes (obtained from the Mobility Command Functional Grouping Indexes) are listed on the maintenance allocation chart in the appropriate numerical sequence. These indexes normally are set up in accordance with their function and proximity to each other. 15. Components and Related Operation. This column contains the functional grouping index heading, subgroup headings, and a brief description of the part starting with the noun name. It also designates the operations to be performed such as service, adjust, inspect, test, replace, repair, and overhaul.

c. Levels of Maintenance. This column contains the various levels of maintenance by number designation. An X placed in the appropriate level column and in line with an indicated maintenance function authorizes that level to perform the function. The X indicates the lowest level responsible for performing the function, but does not necessarily indicate repair parts stockage at that level. Higher levels are authorized to perform the indicated functions of lower levels.

d. Remarks. This column lists specific maintenance functions, special tools, cross-references, instructions, and the like pertinent to the operation being performed.

Section II. MAINTENANCE ALLOCATION CHART

Functional group	Components and related operation	Levels of maintenance					Remarks
		O/C	O	DS	GS	D	
03	FUEL SYSTEM.						
0312	Throttle Controls.						
	Controls, throttle:						
	Replace		X				
06	ELECTRICAL SYSTEM.						
0607	Instrument or Engine Control Panel.						
	Switches; gages; hourmeter; box, instrument housing;						
	tachometer; lamp holder; bulb; panel:						
	Replace		X				
	Cable assembly; wiring:						
	Replace			X			
0608	Miscellaneous Items.						
	Receptacle, slave; switch, turn signal:						
	Replace		X				
0609	Lights.						
	Lights; lens; doors; gaskets:						
	Replace		X				
	Light, rotating:						
	Replace		X				
	Repair X						
0611	Siren.						
	Siren:						
	Replace		X				
	Repair		X				
	Switch:						
	Replace		X				
0612	Batteries.						
	Box, battery:						
	Replace		X				
	Repair		X				
0613	Chassis Wiring Harness.						
	Harness, wiring:						
	Replace			X			
	Repair		X				
0615	Radio Interference Suppression.						
	Components:						
	Test		X				
	Replace		X				
12	BRAKES.						
1208	Air Brake System.						
	Fittings:						
	Replace		X				
	Tubing:						
	Replace		X				
	Repair		X				
18	BODY.						
1808	Hose Reels.						
	Reels, hose:						
	Service	X					
	Replace		X				
	Repair			X			
1812	Special Purpose Bodies.						
	Body:						
	Replace			X			
	Repair		X				

Functional group	Components and related operation	Levels of maintenance					Remarks
		O/C	O	DS	GS	D	
	Doors:						
	Replace		X				
	Repair		X				
	Aprons:						
	Replace		X				
	Tank, water:						
	Service.....	X					
	Inspect.....	X					
	Replace			X			
	Repair			X			
	Brackets; grating; holder, nozzle:						
	Replace	X					
22	ACCESSORY ITEMS.						
2210	Data Plates and Instruction Holders.						
	Plates, data:						
	Replace				X		
	Plates, instruction:						
	Replace		X				
31	BASIC ISSUE ITEMS, MANUFACTURER INSTALLED						
3100	Basic Issue Items, Manufacturer or Depot Installed.						
	Case; publications; accessories:						
	Replace.....		X				
32	BASIC ISSUE ITEMS TROOP INSTALLED.						
3200	Basic Issue Items Troop Installed or Authorized.						
	Tools, common:						
	Replace	X					
40	ELECTRIC MOTORS.						
4000	Motor Assembly.						
	Motors, electric:						
	Replace	X					
4006	Starting and Protective Devices.						
	Switches; solenoids:						
	Replace		X				
47	GAGES.						
4702	Gages, Mounting, Lines and Fittings.						
	Gages:						
	Replace		X				
55	PUMPS. I						
5500	Pump Assembly.						
	Pump, primer:						
	Replace		X				
	Repair.....				X		
	Pump, fire:						
	Replace				X		
	Repair				X		
5501	Impellers, Rotors.						
	Rotor, primer pump:						
	Replace				X		
	Impeller, fire pump:						
	Replace					X	
5505	Suction and/or Discharge Systems.						
	Manifolds; valves:						
	Replace				X		
	Repair.....				X		
	Head, suction:						
	Service.....		X				
	Replace		X				

Functional group	Components and related operation	Levels of maintenance					Remarks
		O/C	O	DS	GS	D	
5507	Doors: Replace		X				
	Valve, solenoid; fittings: Replace		X				
	Tubing: Replace		X				
	Repair		X				
	Pump Drives. Gears; shafts; seals; bearings: Replace			X			
	Tubing: Replace		X				
	Repair		X				
	Universal joint: Service	X					
	Replace		X				
	Repair		X				
	Controls, clutch: Adjust		X				
	Replace		X				
	Repair		X				
	Fittings: Replace		X				
5513	Fluid Lines. Fittings; lines; valves, controls: Replace		X				
76	FIRE FIGHTING EQUIPMENT COMPONENTS.						
7601	Foam Making Units. Tank, storage: Service	X					
	Inspect	X					
	Replace		X				
	Repair		X				
	Valves: Replace			X			
	Rods, valve operating: Service	X					
	Replace			X			
	Pipes; fittings; baffles: Replace		X				
7603	Fire Extinguishers. Extinguishers, fire: Service	X					
	Replace	X					

APPENDIX III
BASIC ISSUE ITEMS LIST AND MAINTENANCE AND OPERATING SUPPLIES

Section I. INTRODUCTION

1. General

Section II lists the accessories, tools, and publications required in 1st level maintenance and operation, initially issued with, or authorized for the Fire Truck. Section III lists the maintenance and operating supplies required for initial operation.

2. Explanation of Columns Contained in Section II

a. Source Codes. The information provided in each column is as follows:

- (1) *Materiel.* This column lists the basic materiel code number of the supply service assigned responsibility for the part. Blank spaces denote supply responsibility of the preparing agency. General Engineer supply parts are identified by the letters GE in parentheses, following the nomenclature in the description column. Other basic materiel code numbers are

8-Medical Materiel
10-Quartermaster Materiel
11-Signal Materiel
12-Adjutant General

- (2) *Source.* The selection status and source of supply for each part are indicated by one of the following code symbols:

- (a) P-applied to high-mortality repair parts which are stocked in or supplied from the supply service depot system, and authorized for use at indicated maintenance levels.
- (b) PI-applied to repair parts which are low-mortality parts, stocked in or supplied from supply service depots, and authorized for installation at indicated maintenance levels.
- (3) Maintenance. The lowest maintenance level authorized to use, stock, install, or

manufacture the part is indicated by the following code symbol:

O-Organizational Maintenance 1 st and 2d level)

b. Federal Stock Number. The Federal stock number will be shown in this column, and will be used for requisitioning purposes.

c. Description.

- (1) The item name and a brief description of the part are shown.
- (2) A five-digit Federal supply code for manufacturers and/or other supply services is shown in parentheses followed by the manufacturer's part number. This number will be used for requisitioning purposes when no Federal stock number is indicated in the Federal stock number column. Example: (08654) 86453
- (3) The letters GE, shown in parentheses immediately following the description, indicates General Engineer supply responsibility for the part.

d. Unit of Issue. If no abbreviation is shown in this column, the unit of issue is "each".

e. Quantity Authorized. This column lists the quantities of repair parts, accessories, tools, or publications authorized for issue to the equipment operator or crew as required.

f. Quantity Issued With Equipment. This column lists the quantities of repair parts, accessories, tools, or publications that are initially issued with each item of equipment. Those indicated by an asterisk are to be requisitioned through normal supply channels, as required.

g. Illustrations. This column provides the following information:

- (1) Figure number. Provides the identifying number of the illustration.

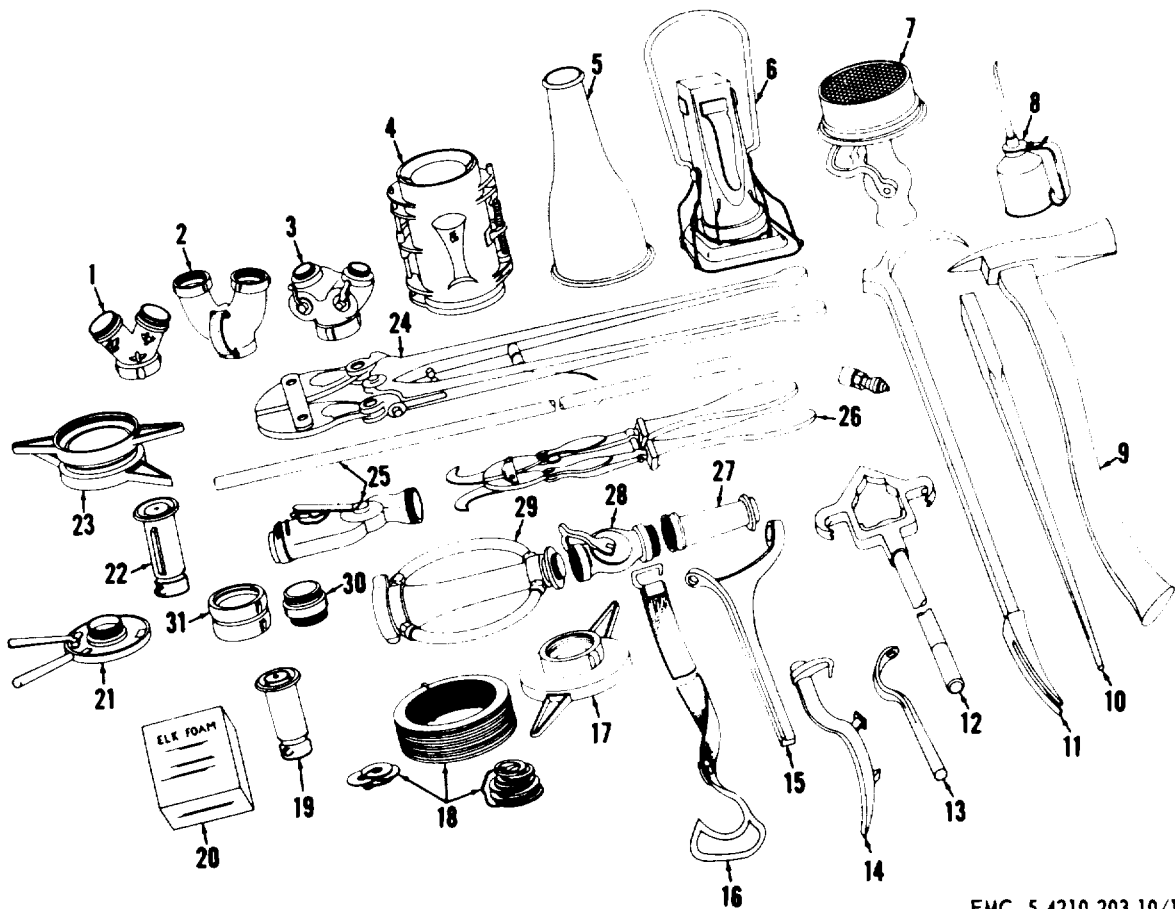

EMC 5-4210-203-10/19

- | | | | |
|---------------------------------|-------------------|-----------------------------|----------------|
| 1 Siamese connection, fire hose | 7 Nozzle | 16 Ladder and hose strap | 25 Nozzle |
| 2 Siamese connection, fire hose | 8 Oiler | 17 Reducer | 26 Bolt cutter |
| 3 Siamese connection, fire hose | 9 Axe | 18 Gasket | 27 Tip |
| 4 Jacket, fire hose | 10 Wrecking bar | 19 Tip | 28 Nozzle |
| 5 Foam shaper | 11 Crowbar | 20 Fire extinguisher charge | 29 Playpipe |
| 6 Lantern | 12 Spanner wrench | 21 Adapter | 30 Nipple |
| | 13 Spanner wrench | 22 Nozzle | 31 Coupling |
| | 14 Spanner wrench | 23 Coupling | |
| | 15 Spanner wrench | 24 Bolt cutter | |

Figure 72. Basic issue items.

(2) *Item number.* Provides the references number for the parts shown in the illustration.

3. Explanation of Columns Contained in Section III

a. Item. This column contains numerical sequenced item numbers, assigned to each component application, to facilitate reference.

b. Component Application. This column identifies the component application of each maintenance or operating supply item.

c. Source of Supply. This column lists the basic materiel code number of the supply service assigned responsibility for the item. Blank spaces denote supply responsibility of the preparing agency. Other basic materiel code number is-

10 Quartermaster Materiel

d. Federal Stock Number. The Federal stock number will be shown in this column and will be used for requisitioning purposes.

e. Deception. The item and a brief description are shown.

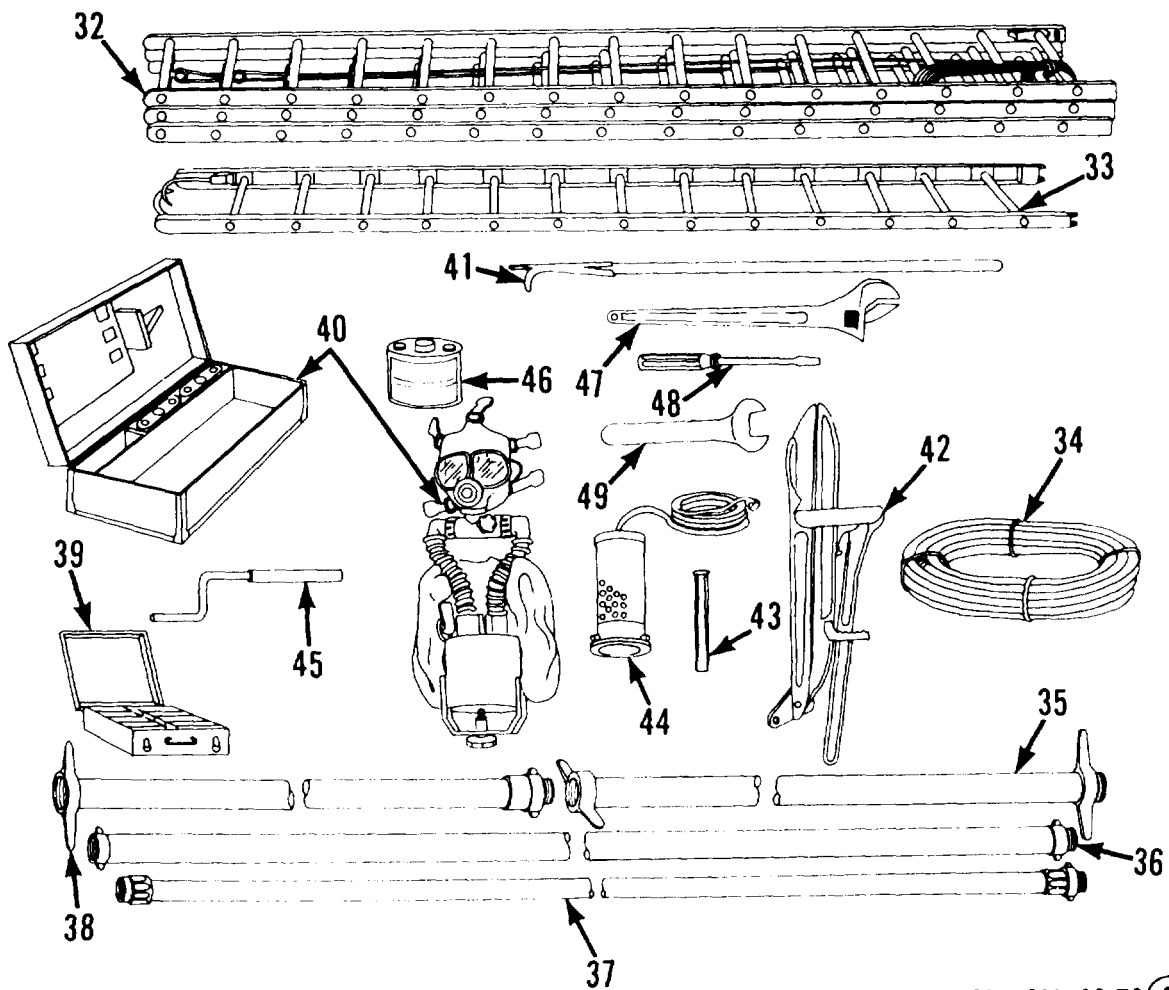

MSC 4210-205-12/72 (2)

- | | | | |
|---------------------|------------------------|--------------------|----------------|
| 32 Extension ladder | 37 Hose | 42 Fire hose clamp | 47 Wrench |
| 33 Roof-type ladder | 38 Hose | 43 Chisel | 48 Screwdriver |
| 34 Rope | 39 First aid kit | 44 Strainer | 49 Wrench |
| 35 Hose | 40 Breathing apparatus | 45 Crank | |
| 36 Hose | 41 Pike pole | 46 Canister | |

Figure 72—Continued

f. *Quantity Required for Initial Operation.* This column lists the quantity of each maintenance or operating supply item required for initial operation of the equipment.

Quantities listed represent the estimated requirements for an average 8 hours of operation.

h. *Notes.* This column contains informative notes keyed to data appearing in the preceding column

g. *Quantity Required for 8 Hours Operation.*

Section II. BASIC ISSUE ITEMS LIST

Source codes				Federal Stock Stock No.	Description	Unit of issue	Expendability	Qty Authorized	Qty Issued with Equipment	Illustrations	
Material	Source	Maintenance	Recoverability							Fig	Item
					GROUP 31 BASIC ISSUE ITEMS, MANUFACTURER INSTALLED 3100 Basic Issue Items, Manufacturer or Depot Installed						
	P1	O	ADAPTER: universal thread, male side 2-1/2 inch NH, female side adjustable, 22 27/32- to 3 1/2- in. od capacity (96821) 1400.	2	2	72	21
11	P	O	BATTERY: dry cell; rectangular, -volt: 2-11/16 in sq, 3 15/16 in. high SIG 3A275-200.	2	2		
11	P	O	BATTERY: dry cell; cylindrical, 1 1/2--volt, 1-11/32 in. diameter, 2-11-32 in. lg SIG, 3A30.	10	10		
11	P	O	BATTERY: dry cell; rectangular, 9-volt, 8 9/16 in lg, 4 1/16 in wide, 5 15/16- in. high SIG 3A275-207.	1	1		
	P1	O	4240-288-9125	BREATHING APPARATUS, OXYGEN GENERATING: with 1 canister and carrying ease.	2	2	72	40
	P	O	4240-204-1917	CANISTER, OXYGEN BREATHING APPARATUS.	4	4	72	46
	P1	O	752-559-9618	CASE: operations and maintenance publications, cotton duck, water repellent and mildew resistant, MIL-B-11743B (GE).	1	1		
	P	O	4210-223-9884	CHARGE, FIRE EXTINGUISHER, ANTI-FREEZE: intended for 5 gallon extinguisher.	6			
	P	O	4210 223-9874	CHARGE, FIRE EXTINGUISHER, FOAM: for 2 1/2- gallon extinguisher.	3	3	72	20
	P1	O	421U 262-7073	CLAMP, FIRE HOSE SHUTOFF: for 2 1/2 and 3 inch hose.	1	1	72	42
	P1	O	4210-288-8816	COUPLING, FIRE HOSE: swivel female, 2 1/2 inch 7 1/2 NH, guard, pin, or rocket lug each end.	2	2	72	31
	P1	O	4210-288-8815	COUPLING, FIRE HOSE: brass swivel female, 4 1/2 inch, 4 NH, long handles each end.	1	1	72	23
	P1	O	CRANK, HAND: booster line hose reel (92858) H-500 F-61.	2	2	72	45
	P	O	4210-223-9915	EXTINGUISHER, FIRE, CARBON DIOXIDE: shatterable cylinder; trigger, button or squeeze grip-control, 15 pound capacity.	2	2		
	P	O	4210-555-8837	EXTINGUISHER, FIRE, MONOBROMOTRI-FLUOROMETHANE: charged hand shatterable cylinder, penetrating seal valve, stored pressure, w/ bracket, 2.75 lbs.	1	1		
	P	O	5210-202-7878	EXTINGUISHER, FIRE, CARBON DIOXIDE: charged, hand type nonshatterable cylinder, 15 pound, squeeze grip control permanent shut-off valve.	1	1		
	P	O	4210-240-7708	EXTINGUISHER, FIRE, FOAM: charged, hand, splash proof, fixed stopple 2 1/2- gallon capacity.	1	1		
	P	O	4210-399 5991	EXTINGUISHER, FIRE, VAPORIZING LIQUID: charged, hand, 1/4- gallon capacity MIL-E-5220A.	1	1		
	P	O	4210-288-8263	EXTINGUISHER, FIRE, VAPORIZING LIQUID: charged, for use w/carbon tetrachloride base; hand type; copper container 1 gallon capacity.	1	1		
	P	O	4210-241-8343	EXTINGUISHER, FIRE, WATER: back pack, steel container, galvanized finish; 6 gallon rated capacity, plunger or trombone pump type.	3	3		

Source codes				Federal Stock Stock No.	Description	Unit of issue	Expendability	Qty Authorized	Qty Issued with Equipment	Illustrations	
Material	Source	Maintenance	Recoverability							Fig	Item
8	P	0	6230-164-6605	FLASHLIGHT: 2 batteries accommodated without batteries, 11/ volt; with miniature screw base lamp nonfocusing.	5	5		
	P	0	4210-243-3065	FOAM LIQUID, DEHYDRATED: fire extinguisher; 5 gallon can.	7	7		
	P1	0	FOAM SHAPER: used with nozzle (51378) model FFF-101 A.	1	1	72	5
	P	0	5330-202-4637	GASKET: rubber, 1/8 in. thk, 1 7/16 in. outside diameter, 1-inch aperture.	10	10	72	18
	P	0	5330-202-4645	GASKET: rubber, 1/8 in. thk, 5 7/8 in. outside diameter, 1 9/16 inch aperture.	10	10	72	18
	P	0	5330-202-4659	GASKET: rubber, 3/16 in. thk, 3 3/16 in. outside diameter, 2 9/16 in. aperture.	10	10	72	18
	P	0	5330-202-666	GASKET: rubber, 1/4 in. thk, 5 7/8 in. outside diameter, 4 9/16 in. aperture.	10	10	72	18
	P	0	4210-202 6712	HOSE ASSEMBLY, RUBBER: chemical hose, 3 braid, for booster line, 1 inch inside diameter, 50 feet long, 1 in. - 8 NH male and female couplings.	6	6	72	37
	P	0	4210-202-716	HOSE ASSEMBLY, RUBBER: suction, 4 inch inside diameter hose, 10 feet long, 4 1/4- in NH male and female couplings, guard, pin, or rocker lug, male fitting; long handles on female fitting.	2	2	72	38
	P	0	4210-288 6810	HOSE, COTTON, RUBBER LINED: double jacket, 1 1/2- in. inside diameter, 50 feet lg, 1 1/2- in. NH male and female couplings, rocker, pin, guard lug.	16	16	72	36
	P	0	4210-288 6812	HOSE, COTTON, RUBBER LINED: double jacket, 2-1/2 in. inside diameter, 50 feet lg, male and female couplings, 2-1/2 inch NH thread, rocker, pin, guard lugs.	24	24	72	36
	P	0	HOSE, COTTON, RUBBER LINED: suction, double jacket, 4-1/2 in. inside diameter hose, 16 ft. lg, 4-1/2 in. NH female couplings, long handles (96821) 1420.	1	1	72	35
	P1	0	4210-241-2864	JACKET, FIRE HOSE: sleeve for 2 1/2 in. inside diameter cotton hose, with pin lugs, 10 inches overall length.	1	1	72	4
	11	P	0	6545-922-1200	KIT, FIRST AID, MOTOR VEHICLE: 12 unit	2	2	72
P1		0	LADDER, FIRE, EXTENSION: aluminum, 3 section, 36 ft lg (96821) 1424.	1	1	72	32
P1		0	4210-241-3206	LADDER, FIRE EXTENSION: automatic type locks, without tormentor poles; 2 sections, single rope spreader, 20 ft lg extended.	1	1		
P1		0	LADDER, FIRE, SINGLE: roof type, aluminum, 14 ft. la, w/folding hooks (96821) 1425.	1	1	72	33
P1		0	4210-260 0921	LADDER, FIRE, SINGLE: roof type, with folding hooks, 12 ft lg, 15 7/8 inches wide.	1	1	72	33
P	0	6230-498 9408	LANTERN, ELECTRIC: 6 volt square dry battery accommodated.	2	2	72	6	
P1	0	4210-288-8827	NIPPLE, HOSE: brass, 2-1/2 in. 7-1/2 NH, with guard, pin, or rocker lug.	2	2	72	30	

Source codes				Federal Stock Stock No.	Description	Unit of issue	Exp- pend ability	Qty Auth- or- ized	Qty Issued with Equip- ment	Illustrations	
Material	Source	Mainte- nance	Re- cover- ability							Fig	Item
10	P1	0	NOZZLE, FIRE, HOSE, WATER: throw handle shutoff, female end, underwriters play pipe thread; male end 1 1/2- inch 9 NH, MIL-N-12314A with amendment, 2, type III, class B, (except with above threads) (96821) 1433.	2	2	72	28
	P1	0	NOZZLE, FIRE HOSE, WATER: adjustable spray and straight stream, 1 1/2 inch-8 NH, MIEN-12314A with amendment 2, type II, clam A (96821) 1427.	2	2	72	22
	P1	0	NOZZLE, FIRE HOSE, WATER: adjustable spray and straight stream, 1 1/2 inch-9 NH, MIL-N 12314A with amendment 2, type II, class A (96821) 1428.	1	1	72	22
	P1	0	NOZZLE, FIRE HOSE, FOAM: combination fog and straight stream, 2 1/2- inch NH, with fog foam screen (51378) Model FFF-101A.	1	1	72	7
	P1	0	NOZZLE, FIRE HOSE, FOAM: combination straight stream fog-foam, 1 1/2 NH, with 6 foot extension applicator (96821) 1431.	2	2	72	25
	P1	0	4210-287-1948	NOZZLE, FIRE HOSE, FOAM: chemical foam type, rigid style, 60 gallon per minute capacity, 1 1/2 in. dia. 9 NH thread inlet.	2	2		
	P1	0	421-288 8261	NOZZLE, FIRE HOSE, WATER: brass, plain removable tip, without playpipe, 1 inch, 8 NH thread female, 3/4- in 11-1/2 NH thread male outlet.	2	2		
	P1	0	4210-289 4299	NOZZLE, FIREHOSE, WATER: brass, removable tip, with stub type playpipe; 2 1/2- inch, 7 1/2 NH thread female with guard, pin, or rocker lug, 2 inch, 14, 60 degree V-form thread, male outlet.	2	2		
	P1	0	421-288 6857	NOZZLE, FIRE HOSE, WATER: brass; three position, 1 1/2- inch 9 NH thread female, with applicator, 10 lt lg.	2	2		
	P	0	7240 243-1116	PAIL, METAL: iron, 3 1/2- gallon, round bottom fire bucket.	4	4		
	P1	0	8340 256-9122	PAULIN: cotton duck cloth; olive drab; 12 ft wide 17 ft lg.	4	4		
	P1	0	4210-344-4601	PLAYPIPE: stub, male end, underwriters play- pipe thread female end, 2-1/2 in. NH, with ladder hook and swivel rubber handles.	2	2	72	29
	P1	0	4210-288 7735	REDUCER, HOSE: 4-1/2 in, 4 NH, female, RH, with long handles; 2-1/2 in, 7 1/2 NH swivel female, guard, pin, or rocker lug.	1	1	72	17
	P1	0	4210288 8845	REDUCER, HOSE: brass, thread female, 3/4- in-14 thread, NPSH, right-hand; thread male, 1 in. - thread, NH, right-hand with guard, pin, or rocker lug.	1	1		
P1	0	421-288 8817	REDUCER, HOSE: brass, thread female, 2 inch- 11 1/2- thd, NPSH, right-hand, thread male, 2- in. 7 1/2- thd, NH, right-hand; with guard, pin, or rocker lug.	1	1			
10	P1	0	4020 228-9664	ROPE, SISAL: circumference, 2-1/4 inch ea, minimum breaking strength, 4320 lbs. 6.00 foot per lb.	LB	25	26	72	34
	P1	0	4210-288 7860	SIAMESE CONNECTION, FIRE HOSE:: 236 in, 7-1/2 in. NH shrivel female inlet, 2 rind male gated outlets, 2-1/2 in. 7-1/2 NH.	1	1	72	1

Source codes				Federal Stock Stock No.	Description	Unit of issue	Ex- pend- ability	Qty Auth- or- ized	Qty Issued with Equip- ment	Illustrations	
Material	Source	Mainte- nance	Re- cover- ability							Fig	Item
	P	O	4210-288 7861	SIAMESE CONNECTION, FIRE HOSE: Sated, swivel female inlet, guard, pin, or rocker lug 2 in, 7 1/2: NH: 2 rigid male outlets, 1-1/2 in, 9 NH.			1	1	72	3
	P1	0	SIAMESE CONNECTION, FIRE HOSE: with clapper valves, 2 1/2 in., 7 1/2 NH male connection, single end; Siamese end, female connections, 2 in. NH (96821) 1409.			1	1	72	2
	P1	0	6230-299 6674	SPOTLIGHT: do, 9 volt, with reflector, parabolic 4 1/2 in. diameter; with 4 1/2 in. diameter glass lens, with carrying case and strap.			1	1	72	
	P1	0	4210-240-5531	STRAINER, SUCTION, FIRE HOSE: brass, 4 1/2 in. diameter, 3/8 in. perforations, guard, pin, or rocker lug, rigid female connection, 4 1/2 in. 4 NH; with 30-foot rope.			1	1	72	44
	P	0	4210-252-3378	STRAP, HOSE, AND LADDER: 24 inches long, 1 1/4 in. wide, 4 in. iron hooks each end.			4	4	72	16
	P1	0		TIP, NOZZLE, FIRE HOSE: brass, nonadjustable, rigid female inlet, 1-1/2 in.-9 NH, 1 in. discharge opening, MIL:SPEC-T-12167A with amendment 1, class C, (except with above thread) (96821) 1435.			2	2	72	19
	P1	0		TIP, NOZZLE, FIRE HOSE: brass, nonadjustable, rigid female inlet, 1-1/2 in. 9 NH, 1 1/8 in. dim charge opening, MIL-SPEC-T-12167A with amendment 1, class C (except with above thread) (96821) 1436.			2	2	72	19
	P1	0		TIP, NOZZLE, FIRE HOSE: brass, nonadjustable, rigid female inlet, 1-1/2 in., opening, MIL SPEC-T-12167A with amendment 1, class C (except with above thread) (96821) 1437.			2	2	72	19
	P1	0	4210-240-8793	TIP, NOZZLE, FIRE HOSE: 2 in. diameter, female underwriter's standard tip thread, 4 1/2 in. minimum length, outlet 1 inch diameter.			2	2	72	19
	P1	0	4210-287-5025	TIP, NOZZLE, FIRE HOSE: nonadjustable, brass inlet; -3/4 in. diameter, female, NH thread, outlet, -1/4 in. diameter, 3- in. minimum length.			2	2	72	19
	P1	0	4210-240-8790	TIP, NOZZLE, FIRE HOSE: 2 inch diameter, female underwriter's standard tip thread, 4 1/2 inch minimum length, outlet 1 1/8 inch diameter.			1	1	72	19
	P1	0	4210-240 8791	TIP, NOZZLE, FIRE HOSE: 2 inch diameter, female underwriter's standard tip thread, 4 1/2 inch minimum length, outlet, 1-1/4 inch diameter.			1	1	72	19
	P	O	4210-223-9870	VAPORIZING LIQUID, FIRE EXTINGUISHER: colored solution, 5 gallon can.			1	1		
	P	O	4210-142-4949	AX, PICK HEAD: 6 lb, 5 in. cutting edge, 36 in. handle.			2	2	72	9
10	P	O	5120-257 0303	BAR, WRECKING: 1 1/2 in. diameter stock, 43 in. lg.			1	1	72	10
12					DEPARTMENT OF THE ARMY LUBRICATION ORDER LO 5-21-205-12.			1	1		
12					DEPARTMENT OF THE ARMY OPERATOR'S AND ORGANIZATIONAL MAINTENANCE MANUAL TM 5 4210-205-12.			2	2		

Source codes				Federal Stock Stock No.	Description	Unit of issue	Expendability	Qty Authorized	Qty Issued with Equipment	Illustrations	
Material	Source	Maintenance	Recoverability							Fig	Item
					GROUP 32-BASIC ISSUE ITEMS TROOP INSTALLED 3200-BASIC ISSUE ITEMS TROOP INSTALLED ON AUTHORIZED						
10	P	O	5110-23-3272	CHISEL, COLD, HAND: 3/4- in. cut, 7 in. lg	1	*	72	43
10	P	O	5120-224-1344	CROWBAR: 7/8 in. diameter stock, 37 in. lg	1	1	72	11
10	P	O	5110-188-2519	CUTTER, BOLT: 3/4 in. capacity, 48 in. lg	1	1	72	24
10	P	O	5110-256-9212	CUTTER, BOLT: with insulated handles, 3/8 in capacity with groping hook.	1	1	72	26
	P	O	5120 222-4374	MATTOCK: cutter; with handle 5 lb	2			
10	P	O	4930-273-3644	OILER, HAND: pump force fed 8 ounce capacity	1	*	72	8
	P1	O	5120-243-2766	PIKE POLE: 8 foot handle.....	1	1	72	41
10	P	O	5120-227-7349	SCREWDRIVER, FLAT TIP: 3/8- in. width tip, 11-1/4 in. lg.	1	*	72	48
	P	O	5120-188-8450	SHOVEL, HAND: round point; long handle, number 2 open back.	2	2		
	P	O	5120-224-9326	SHOVEL, HAND: square point D-handle; number 2; blade, 11-1/2 to 12-1/2 in. lg. 9-1/2 to 10 1/4 in. wide, open back.	2	2		
10	P	O	5120-240-1414	WRENCH, OPEN END, ADJUSTABLE: 0 to 2 1/16 in. opening, 18 in. lg.	1	*	72	47
10	P	O	5120 601-2498	WRENCH, OPEN END, FIXED: 1 13/16 in. opening	1	*	72	49
10	P	O	5120-293-1089	WRENCH, SPANNER: combination hydrant and spanner, adjustable.	2	2	72	12
10	P	O	5120-293 0705	WRENCH, SPANNER: hose coupling type, 4 1/2 in. diameter circle.	2	2		
10	P	O	5120-640-0608	WRENCH, SPANNER: pin type -1/4 in. minimum to 5/16- in. maximum pin diameter, 1.660 diameter circle.	2	2		
10	P	O	5120-336-5689	WRENCH, SPANNER: pin lug for 3/4 to 1 in. hose couplings.	2	2	72	13
10	P	O	5120-049-7953	WRENCH, SPANNER: pin lug for 4-1/2 in. hose couplings.	2	2	72	15
10	P	O	5120 293-1602	WRENCH, SPANNER: universal pin rocker guard lug type.	4	4	72	14

Section III. MAINTENANCE AND OPERATING SUPPLIES

Item	Component Application	Source of supply	Federal Stock No.	Description	Quantity required for initial operation	Quantity required for 8 hours operation	Notes
1.	5600 PUMP ASSEMBLY.	OIL, LUBRICATING: 5-gal pail as follows:			(1) See SM 10 C-910-SL for
		10	9150-231-6653(1)	Grade 9250 or.....	2 qt	(2)	additional data and requisitioning procedure. (2) See current LO for grade application and replacement intervals.
		10	9160-266-9435(1)	OE-30.....	2 qt	(2)	
		10	9150-231-9037(1)	Grade 9110 or.....	2 qt	(2)	
		10	9150-265-9428(1)	OE-10.....	2 qt	(2)	
10	9150 242-7601(1)	OES	2 qt	(2)			
2.	GREASE POINTS...	GREASE, AUTO- MOTIVE AND ARTILLERY: 1-lb can as follows:			(3) Use oil as prescribed in item 1.
		10	9160-190 0904(1)	GAA.....	As rqr	(2)	
3.	5500 TANK, PRIMING PUMP.	OIL, LUBRICATING (3)	6 qt	(2)	

INDEX

	Paragraph	Page		Paragraph	Page
Adjustments:			Demolition to render equipment inoperative.....	137	97
Hose reel motor adjustment	104d	70	Description	3	2
Air system:			Detailed lubrication information	33	31
Air tank tubing and fittings.....	78	69	Difference in models	5	5
General	77	58	Discharge pressure gage	116	79
Air tank tubing and fittings.....	78	59	Drain valve and tubing	130	91
Apron	119	81	Draining and flushing details	20	20
Axe, team, cutter, compartment accessories			Drive chain	124	86
brackets	69	50	Dome light	98	Be
Battery charging receptacles	111	75	Dome light switch	99	B9
Beacon warning light.....	84	62	Electrical system:		
Beacon warning light switch	91	65	Battery charging receptacles	111	75
Battery box	74	54	Beacon warning light.....	84	62
Carbon dioxide and carbon tetrachloride			Beacon warning light switch	91	65
type fire extinguisher	28	29	Circuit breakers	90	65
Circuit breakers	90	65	Dome light	98	68
Compartment accessory doors, battery box,			Dome light switch	99	69
and oil pan heater adapter:			Engine light switch	101	68
Axe, bars, cutter, compartment acces-			Engine oil pressure sending unit.....	87	63
sories brackets	69	50	Engine temperature sending unit.....	88	63
Battery box	74	54	Flasher assembly	88	65
Compartment door assemblies	72	53	Front directional light assembly.....	81	60
Extinguisher compartment accessories.....	70	53	General	79	59
First aid bracket, hand lantern bracket,			Hose reel switch	102	70
and fitting compartment	71	53	Hose reel motor	104	70
General	68	50	Hose reel motor solenoid relay	103	70
Oil pan heater adapter	73	54	Microswitch	107	72
Compartment door assemblies	72	53	Primer pump motor	106	72
Controls and instruments:			Primer pump motor solenoid relay.....	105	70
Controls and instruments	14	9	Pump gage panel light	97	68
General	13	9	Pump gage panel light switch.....	100	69
Controls, instruments, and panels:			Pump gage panel warning light	96	67
Apron.....	119	81	Rear floodlight	108	72
Discharge pressure gage	116	79	Rear directional light	109	74
General	112	77	Siren and flasher unit.....	82	60
Left side control panel and pan.....	114	78	Siren foot switch	85	67
Pump compartment panel	120	82	Siren hand switch	94	66
Pump gage control panel	118	81	Siren light switch	92	65
Right side control panel and pan	113	77	Siren solenoid relay	86	63
Tachometer-hourmeter	115	79	Spotlight	83	62
Vacuum and hydrant pressure gage	117	79	Taillights	110	74
Demolition by explosive weapons fire.....	138	97	Troubleshooting	45 47	41-42
Demolition of fire truck to prevent enemy			Turn signal switch	93	66
use:			Underhood lights	85	63
Demolition by explosives or weapons			Wiring	80	60
fire	138	97	Engine light switch	101	69
Demolition to render equipment inoper-			Engine oil pressure sending unit.....	87	63
ative.....	137	97	Engine temperature sending unit.....	88	63
General	13B	97	Extinguisher compartment accessories	70	63
Other demolition methods	139	97	Field expedient repairs:		
Training	140	97	Field expedient repairs	48	42
			Loss of water or foam	50	43

	Paragraph	Page		Paragraph	Page
Transfer case lever disengages	49	42	Operation of equipment:		
Fire extinguisher bracket	59	46	Draining and flushing details	20	20
First aid bracket, hand lantern bracket, and fitting compartment	71	53	Final test before hosing fire truck after returning from fire	21	20
Flasher assembly	89	65	General	15	13
Foam nozzle retainer	54	47	Priming water pump and filling tank	18	14
Folding steps	B6	49	Pumping details	19	20
Foam tank strainer, foam tank and vent hose	127	89	Starting the engine	16	14
Front directional light assembly.....	81	60	Stopping the engine	17	14
Fuel system:			Operation at high altitude	27	29
General	76	67	Operation in extreme cold (below 0° F.).....	22	25
Throttle control linkage	76	58	Operation in extreme heat	23	27
Handrails and brackets	58	46	Operation in salt water areas.....	26	29
Heat exchanger and tubing.....	131	93	Operation in sandy or dusty areas.....	24	27
Hose bed assemblies	66	46	Operation under rainy or humid condi tions.....	25	29
Hose bed partition	57	46	Troubleshooting	38, 39,41-43	41
Hose reel	123	86	Operation under rainy or humid conditions.....	25	29
Hose reel motor	104	70	Operator and organizational maintenance tools and equipment:		
Hose reel motor solenoid relay	103	70	Basic issue tools and equipment	31	31
Hose reel switch	102	70	Special tools or equipment	30	31
Hose retainers	65	47	Preventive maintenance services:		
Identification and tabulated data.....	4	5	Daily preventive maintenance services	35	35
Inspecting and servicing equipment.....	8	7	General	34	35
Inspection and maintenance of equipment in storage	144	100	Quarterly preventive maintenance serv ices	36	3S
Installation or setting up instructions	10	7	Preparation of equipment for shipment.....	141	99
Interference suppression components	52	42	Preparation of equipment for storage	143	100
Ladder support assemblies	53	47	Primer pump	122	83
Left side control panel and pan	114	78	Primer pump motor	105	72
Limited storage:			Primer pump motor solenoid relay	105	70
Inspection and maintenance of equip ment in storage	144	100	Priming water pump and filling tanks.....	18	14
Preparation of equipment for storage	143	100	Pump clutch linkage	126	86
Lubrication:.....	33	31	Pump compartment panel	120	82
Detailed lubrication information			Pump drive universal joint.....	129	91
General lubrication information	32	31	Pump gage control panel	118	81
Lubrication system:			Pump gage panel light	97	B8
General	134	96	Pump gage panel light switch.....	100	69
Oil tank and lines	135	96	Pump gage panel wiring light	96	B7
Microswitch	107	72	Pumping details	19	20
Monobromotrnuoromethane and foam type fire extinguishers	29	29	Pumping system:		
Movement to a new worksite:			Drain valve and tubing	130	91
Dismantling for movement	11	g	Drive chain	124	85
Reinstallation after movement	12	9	Foam tank strainer, foam tank and vent hose	127	89
Oil pan heater adapter	73	54	General	121	83
Oil tank and lines	135	96	Heat exchanger and tubing.....	131	93
Operation at high altitude	27	29	Hose reel	123	86
Operation in extreme cold (below 0° F.).....	22	25	Primer pump	122	83
Operation in extreme heat.....	23	27	Pump thatch linkage	126	86
Operation in salt-water areas	26	29	Pump drive universal joint.....	129	91
Operation in sandy or dusty areas.....	24	27	Relief valve control	132	94
Operation of auxiliary materiel used in con junction with fire truck:			Suction and discharge heads and screens...	125	86
Carbon dioxide and carbon tetrachloride type fire extinguishers	28	29	Troubleshooting	40, 44	41
Monobromotrifloromethane and foam type fire extinguishers	29	29	Water pump packing	133	94
			Water tank and lines	128	89
			Radio interference suppression:		
			General methods used to attain sup pression	51	42

	Paragraph	Page
Interference suppression components... ..	62	42
Replacement of suppression components ...	53	42
Testing of radio interference suppression component	54	44
Rear directional light	109	74
Rear flood switch	108	72
Rear step	61	46
Record and report forms	2	2
Relief valve control	132	94
Replacement of suppression components... ..	53	42
Retainers, steps, tool box door, guards, hose bed assemblies and ladder support assemblies:		
Fire extinguisher bracket	59	46
Foam nozzle retainer	64	47
Folding steps	66	49
General	55	44
Handrails and bracket	58	46
Hose bed assemblies	56	46
Hose bed partition	57	46
Hose retainer	65	47
Ladder support assemblies.....	63	47
Rear step	61	46
Shovel brackets	62	46
Splash guards	67	49
Tool box door	DO	46
Right-side control panel and pan.....	113	77
Service upon receipt of equipment:		
Inspecting and servicing equipment.....	8	7
Installation of separately packed components	9	7
Installation or setting up instructions.....	10	7

	Paragraph	Page
Unloading the equipment	6	7
Unpacking the equipment	7	7
Shipment within zone of interior:		
Loading equipment for shipment	142	99
Preparation of equipment for shipment.....	141	99
Shovel brackets	62	46
Siren and flasher light	82	60
Siren foot switch	95	67
Siren hand switch	94	66
Siren light switch	92	65
Siren solenoid relay	86	B3
Splash guards	B7	49
Stoplight	83	62
Suction and discharge heads and screens.....	125	8B
Tachometer-hourmeter	115	79
Taillights	110	74
Throttle control linkage	76	58
Tool box door	60	46
Troubleshooting:		
Electrical system	45-47	41-42
General	37	41
Operation of equipment.....	38,39,41-43	41
Pumping system	40,44	41
Turn signal switch	93	66
Underhood lights	85	63
Unloading the equipment	6	7
Unpacking the equipment.....	7	7
Vacuum and hydrant pressure gage.....	117	79
Water tank and lines.....	128	89
Wiring	80	60

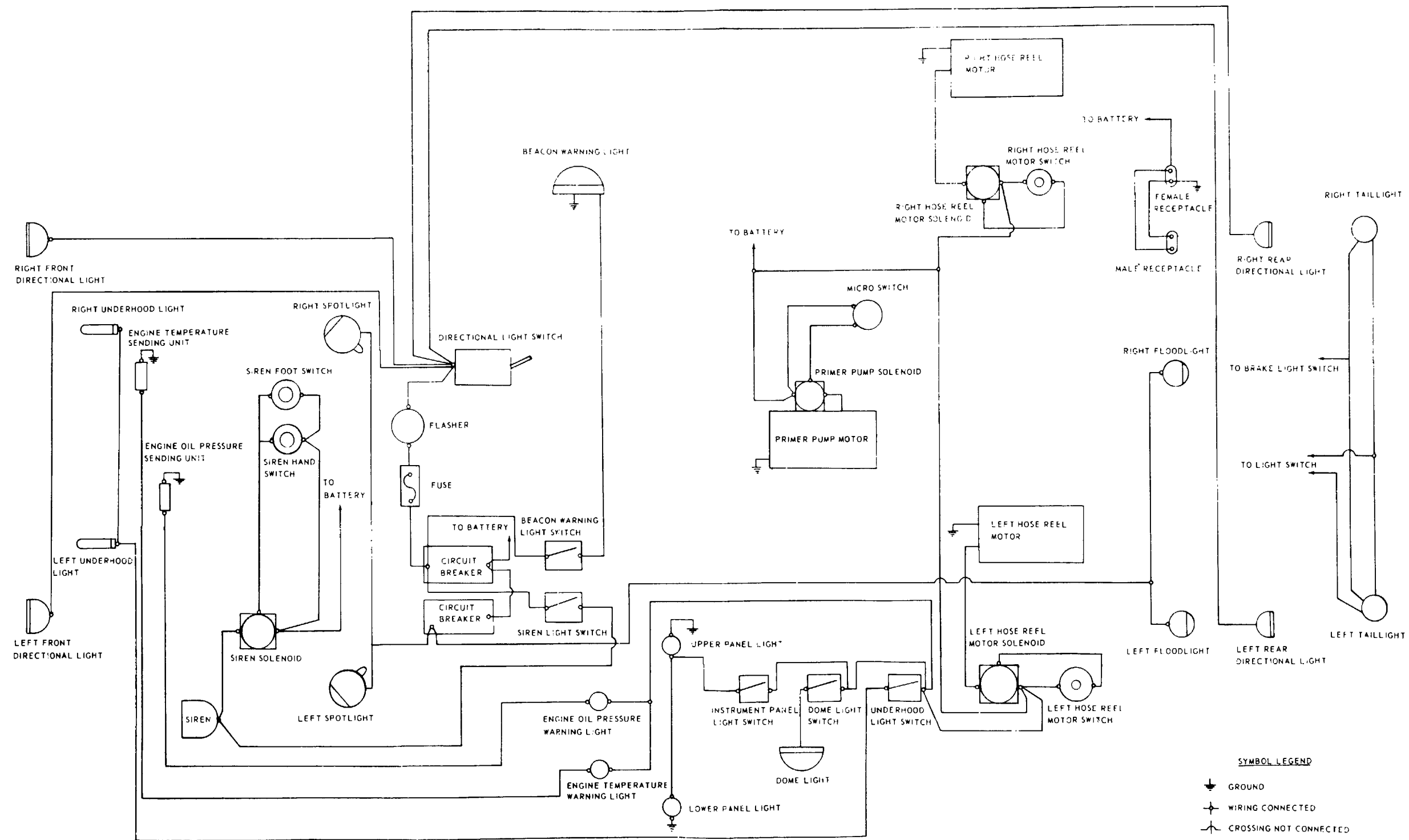

MSC 4210-205-12/3

Figure 3. Wiring diagram.

By Order of the Secretary of the Army:

HAROLD K. JOHNSON,
General, United States Army
Chief of Staff.

Official:

J. C. LAMBERT,
Major General, United States Army,
The Adjutant General.

Distribution:

Active Army:

USASA (2)	USMA (2)
ACSI (1)	GENDEP (OS) (10)
DCSLOG (1)	Engr Dep (OS) (10)
CNGB (1)	Army Dep (2)
TSG (1)	USA Trans Tml Comd (2)
CofEngrs (1)	USA Tml (1)
C/COMMEL (1)	USAOSA (2)
CofT (1)	Div Engr (2)
CofSptS (1)	Engr Dist (2)
USA Maint Bd (1)	USAERDL (3)
USAARTYBD (2)	USA Mbl Equip Cen (46)
USAARMBD (2)	Engr Cen (5)
USAIB (2)	USAREUR EnBr Proc Cen (2)
USAADB (2)	USAREUR Engr Sup Con Agcy (10)
USAAESWBD (2)	Chicago Proc Ofc (10)
USAAVNBD (2)	Engr Fld Maint Shops (2)
USCONARC (3)	Fld Comd, DASA (8)
OS Maj Comd (5) except	AMS (3)
USASETAF (2) USARJ (10)	USAREURCOMZ (2)
USAMOCOM (2)	USA Corps (1)
USASMCOM (1)	MAAG (1)
MDW (1)	JBUSMC (1)
Armies (2)	Units org under fol TOE: (2 ea UNOINDC)
Corps (2)	5-48
Div (2)	5-237 (5)
Engr Bde (1)	5-262 (5)
Svc Colleges (2)	5-267 (1)
Br Svc Sch (2) except	5-278 (5)
USAES (100)	5-279

NG: State AG (3).

USAR: Same as active Army except allowance is one copy to each unit.

For explanation of abbreviations used, see AR 320-50.

☆ U.S. GOVERNMENT PRINTING OFFICE 1984-764-028/5088

The Metric System and Equivalents

Linear Measure

1 centimeter = 10 millimeters = .39 inch
 1 decimeter = 10 centimeters = 3.94 inches
 1 meter = 10 decimeters = 39.37 inches
 1 dekameter = 10 meters = 32.8 feet
 1 hectometer = 10 dekameters = 328.08 feet
 1 kilometer = 10 hectometers = 3,280.8 feet

Weights

1 centigram = 10 milligrams = .15 grain
 1 decigram = 10 centigrams = 1.54 grains
 1 gram = 10 decigrams = .035 ounce
 1 decagram = 10 grams = .35 ounce
 1 hectogram = 10 decagrams = 3.52 ounces
 1 kilogram = 10 hectograms = 2.2 pounds
 1 quintal = 100 kilograms = 220.46 pounds
 1 metric ton = 10 quintals = 1.1 short tons

Liquid Measure

1 centiliter = 10 milliliters = .34 fl. ounce
 1 deciliter = 10 centiliters = 3.38 fl. ounces
 1 liter = 10 deciliters = 33.81 fl. ounces
 1 dekaliter = 10 liters = 2.64 gallons
 1 hectoliter = 10 dekaliters = 26.42 gallons
 1 kiloliter = 10 hectoliters = 264.18 gallons

Square Measure

1 sq. centimeter = 100 sq. millimeters = .155 sq. inch
 1 sq. decimeter = 100 sq. centimeters = 15.5 sq. inches
 1 sq. meter (centare) = 100 sq. decimeters = 10.76 sq. feet
 1 sq. dekameter (are) = 100 sq. meters = 1,076.4 sq. feet
 1 sq. hectometer (hectare) = 100 sq. dekameters = 2.47 acres
 1 sq. kilometer = 100 sq. hectometers = .386 sq. mile

Cubic Measure

1 cu. centimeter = 1000 cu. millimeters = .06 cu. inch
 1 cu. decimeter = 1000 cu. centimeters = 61.02 cu. inches
 1 cu. meter = 1000 cu. decimeters = 35.31 cu. feet

Approximate Conversion Factors

<i>To change</i>	<i>To</i>	<i>Multiply by</i>	<i>To change</i>	<i>To</i>	<i>Multiply by</i>
inches	centimeters	2.540	ounce-inches	Newton-meters	.007062
feet	meters	.305	centimeters	inches	.394
yards	meters	.914	meters	feet	3.280
miles	kilometers	1.609	meters	yards	1.094
square inches	square centimeters	6.451	kilometers	miles	.621
square feet	square meters	.093	square centimeters	square inches	.155
square yards	square meters	.836	square meters	square feet	10.764
square miles	square kilometers	2.590	square meters	square yards	1.196
acres	square hectometers	.405	square kilometers	square miles	.386
cubic feet	cubic meters	.028	square hectometers	acres	2.471
cubic yards	cubic meters	.765	cubic meters	cubic feet	35.315
fluid ounces	milliliters	29.573	cubic meters	cubic yards	1.308
pints	liters	.473	milliliters	fluid ounces	.034
quarts	liters	.946	liters	pints	2.113
gallons	liters	3.785	liters	quarts	1.057
ounces	grams	28.349	liters	gallons	.264
pounds	kilograms	.454	grams	ounces	.035
short tons	metric tons	.907	kilograms	pounds	2.205
pound-feet	Newton-meters	1.356	metric tons	short tons	1.102
pound-inches	Newton-meters	.11296			

Temperature (Exact)

°F	Fahrenheit temperature	5/9 (after subtracting 32)	Celsius temperature	°C
----	---------------------------	-------------------------------	------------------------	----

PIN: 005824-003

This fine document...

Was brought to you by me:



[Liberated Manuals -- free army and government manuals](#)

Why do I do it? I am tired of sleazy CD-ROM sellers, who take publicly available information, slap “watermarks” and other junk on it, and sell it. Those masters of search engine manipulation make sure that their sites that sell free information, come up first in search engines. They did not create it... They did not even scan it... Why should they get your money? Why are not letting you give those free manuals to your friends?

I am setting this document FREE. This document was made by the US Government and is NOT protected by Copyright. Feel free to share, republish, sell and so on.

I am not asking you for donations, fees or handouts. If you can, please provide a link to liberatedmanuals.com, so that free manuals come up first in search engines:

<A HREF=<http://www.liberatedmanuals.com/>>Free Military and Government Manuals

- Sincerely
Igor Chudov
<http://igor.chudov.com/>
- [Chicago Machinery Movers](#)