

**OPERATOR'S AND ORGANIZATIONAL
MAINTENANCE MANUAL
(INCLUDING REPAIR PARTS
AND SPECIAL TOOLS LIST)**

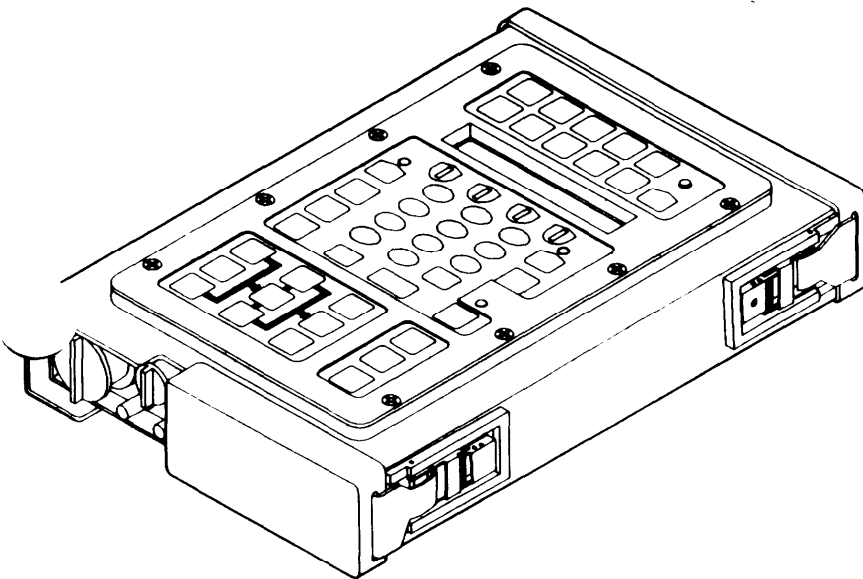

MORTAR BALLISTICS COMPUTER SET

M 2 3

(1220-01-119-6049)

INTRODUCTION 1-1

OPERATING INSTRUCTIONS 2-1

OPERATOR MAINTENANCE 3-1

**ORGANIZATIONAL
MAINTENANCE 4-1**

REFERENCES A-1

**MAINTENANCE
ALLOCATION CHART B-1**

**COMPONENTS OF END ITEM
& BASIC ISSUE ITEMS LISTS C-1**

**EXPENDABLE/DURABLE
SUPPLIES
& MATERIALS LIST D-1**

**REPAIR PARTS &
SPECIAL TOOLS LIST E-1**

**GLOSSARY (INCLUDING
ERROR MESSAGES)**

INDEX

WARNING

Type BA-5588/U lithium organic batteries or cells are used in this equipment. They are potentially dangerous if misused or tampered with before, during, or after discharge. The following safety rules must be strictly observed to prevent possible personnel injury or equipment damage:

DO NOT heat, burn, crush, puncture, disassemble, or otherwise mutilate the batteries.

DO NOT short circuit, recharge, or bypass internal fuse.

DO NOT store in equipment during periods of nonuse in excess of 30 days.

TURN OFF the equipment immediately if you detect battery compartment becoming unusually hot, hear battery cells venting (hissing sound), or smell sulphur dioxide gas.

Remove battery, let it cool for 30 to 60 minutes, then dispose of it per current regulations.

FAILURE TO OBSERVE THIS WARNING COULD RESULT IN PERSONAL INJURY.

FIRST AID DATA

Refer to FM 21-11 (First Aid for Soldiers) for additional first aid data.

a

**TM 9-1220-246-12&P
C3**

CHANGE

NO. 3

**HEADQUARTERS
DEPARTMENT OF THE ARMY**
Washington D. C., 9 August 1995

**OPERATORS AND ORGANIZATIONAL
MAINTENANCE MANUAL
(INCLUDING REPAIR PARTS AND
SPECIAL TOOLS LIST)**

**MORTAR BALLISTICS COMPUTER SET, M23
(1220-01-119-6049)**

TM 9-1220-246-12&P, 27 August 1985, is changed as follows:

1. Remove old pages and insert new pages indicated below.
2. New or changed material is indicated by vertical bar in the margin of the page or pointing hand.

Remove Pages

2-37 and 2-38
2-59 and 2-60
2-71 and 2-72
2-91 and 2-92
2-99 and 2-100

Insert Pages

2-37 and 2-38
2-59 and 2-60
2-71 and 2-72
2-91 and 2-92
2-99 and 2-100

3. File this change sheet in the back of the publication for reference purposes.

By Order of the secretary of the Army:

DENNIS J. REIMER
General, United States Army
Chief of Staff

Official:

JOEL B. HUDSON

Acting Administrative Assistant to the
Secretary of the Army
00509

DISTRIBUTION: To be distributed in accordance with DA Form 12-41-E, block 0025 requirements for TM 9-1220-246-12&P.

CHANGE

NO. 2

HEADQUARTERS
DEPARTMENT OF THE ARMY
Washington D. C., 18 October 1994

OPERATORS AND ORGANIZATIONAL
MAINTENANCE MANUAL
(INCLUDING REPAIR PARTS AND
SPECIAL TOOLS LIST)

MORTAR BALLISTICS COMPUTER SET, M23
(1220-01-119-6049)

TM 9-1220-246-12&P, 27 August 1985, is changed as follows:

1. Remove old pages and insert new pages indicated below.
2. New or changed material is indicated by vertical bar in the margin of the page or pointing hand.

Remove Pages

i and ii
1-1 and 1-2
2-1 and 2-2
2-7 and 2-8
2-15 and 2-16
2-37 and 2-38
2-55 thru 2-68
2-73 thru 2-76
2-79 and 2-80
2-91 thru 2-94
2-97 thru 2-100
2-105 and 2-106
2-109 and 2-110
2-113 thru 2-116

2-125 thru 2-144
B-3 thru B-8
C-3/(C-4 Blank)
E1-1 and E2-1
I-1 and I-2
Glossary 5 and Glossary 6
Glossary 9 thru Glossary 12
Glossary 17 thru Glossary 20

Insert Pages

i and ii
1-1 and 1-2
2-1 and 2-2
2-7 and 2-8
2-15 and 2-16
2-37 and 2-38
2-55 thru 2-68
2-73 thru 2-76
2-79 and 2-80
2-91 thru 2-94.4
2-97 thru 2-100(2-100.2 Blank)
2-105 and 2-106
2-109 and 2-110
2-113 thru 2-116.1/(2-116.2
Blank)
2-125 thru 2-144
B-3 thru B-8
C-3/(C-4 Blank)
E1-1 and E2-1
I-1 and I-2
Glossary 5 and Glossary 6
Glossary 9 thru Glossary 12
Glossary 17 thru Glossary 20

3. File this change sheet in the back of the publication for reference purposes.

By Order of the Secretary of the Army:

GORDON R. SULLIVAN
General, United States Army
Chief of Staff

Official:

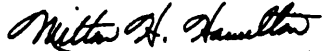

MILTON H. HAMILTON

*Administrative Assistant to the
Secretary of the Army*

07379

DISTRIBUTION: To be distributed in accordance with DA Form 12-41-E, Block 0025 requirements for TM 9-1220-246-12&P.

CHANGE

HEADQUARTERS
DEPARTMENT OF THE ARMY

NO. 1

Washington D. C., 2 January 1990

**OPERATOR'S AND ORGANIZATIONAL
MAINTENANCE MANUAL
(INCLUDING REPAIR PARTS AND
SPECIAL TOOLS LIST)**

**MORTAR BALLISTICS COMPUTER SET, M23
(1220-01-119-6049)**

TM 9-1220-246-12&P, 27 August 1985, is changed as follows:

1. Remove old pages and insert new pages indicated below.
2. New or changed material is indicated by vertical bar in the margin of the page.

Remove pages

2-1 and 2-2
2-37 and 2-38
2-65 and 2-66
Fig E1-1 thru E2-2
I-1 and I-2
Glossary 9 and Glossary 10
Glossary 15 and Glossary 16
Glossary 17 and Glossary 18
Glossary 19 and Glossary 20

Insert pages

2-1 and 2-2
2-37 and 2-38
2-65 and 2-66
E1-1 and E2-1
I-1 and I-2
Glossary 9 and Glossary 10
Glossary 15 and Glossary 16
Glossary 17 and Glossary 18
Glossary 19 and Glossary 20

3. File this change sheet in back of the publication for reference purposes.

By Order of the Secretary of the Army:

CARL E. VUONO
General, United States Army
Chief of Staff

Official:

WILLIAM J. MEEHAN II
Brigadier General, United States Army
The Adjutant General

DISTRIBUTION: To be distributed in accordance with DA Form 12-41, Operator and Unit Maintenance requirements for Computer Ballistic Drive, Mortar M23.

OPERATOR'S AND ORGANIZATIONAL
MAINTENANCE MANUAL
(INCLUDING REPAIR PARTS AND SPECIAL TOOLS LIST)
MORTAR BALLISTICS COMPUTER SET M23
(1220-01-119-6049)

Current as of 24 May 1994 for Appendix E

REPORTING ERRORS AND RECOMMENDING IMPROVEMENTS

You **can** help improve this manual. If you find any mistakes or if you know of a way to improve the procedures, please let us know. Mail your letter, DA Form 2028 (Recommended Changes to Publications and Blank Forms), or DA Form 2028-2 located in back of this manual direct to: Commander, US Army Armament, Munitions, and Chemical Command, ATTN: AMSMC-MAS, ROCK ISLAND, XL 61299-6000. A reply will be furnished to you.

		Page	Illus/ Figure
	HOW TO USE THIS MANUAL	iv	
CHAPTER 1	INTRODUCTION	1-1	
Section I	General Information	1-1	
Section II	Equipment Description and Oat	1-4	
Section III	Principles of Operation	1-11	
CHAPTER 2	OPERATING INSTRUCTIONS	2-1	
Section I	Description and Use of Operator's Control and Indicators	2-1	
Section II	Operator Preventive Maintenance Checks and Services (PMCS)	2-21	

	Page	Illus/ Figure
Section III	Operation Under Usual Conditions	2-24
Section IV	Operation Under Unusual Conditions	2-159
CHAPTER 3	OPERATOR MAINTENANCE	3-1
Section I	Lubrication Instructions	3-1
Section II	Troubleshooting Procedures	3-1
Section III	Maintenance Procedures	3-1
CHAPTER 4	ORGANIZATIONAL MAINTENANCE	4-1
Section I	Repair Parts, Special Tools, TMDE, and Support Equipment	4-1
Section II	Service Upon Receipt	4-2
Section III	Organizational Preventive Maintenance Checks and Services (PMCS)	4-2
Section IV	Troubleshooting	4-3
Section V	Maintenance Procedures	4-4
Section VI	Preparation for Storage or Shipment,	4-6
APPENDIX A	REFERENCE	A-1
APPENDIX B	MAINTENANCE ALLOCATION CHART	B-1
APPENDIX C	COMPONENTS OF END ITEM AND BASIC ISSUE ITEMS LISTS	C-1
APPENDIX D	EXPENDABLE/DURABLE SUPPLIES AND MATERIALS LIST	D-1

		Page	Illus/ Figure
APPENDIX E	REPAIR PARTS AND SPECIAL TOOLS LIST	E-1	
Section I	INTRODUCTION	E-1	
Section II	REPAIR PARTS LIST	E1-1	
Group 00	Computer set, ballistics: mortar 23 (11785850)	E1-1	E1
Group 01	Computer, ballistics: mortar (1) (11785700-1)	E2-1	E2
Section III	SPECIAL TOOLS LIST	Not applicable	
Section IV	NATIONAL STOCK NUMBER AND PART NUMBER INDEX	I-1	
	GLOSSARY (INCLUDING ERROR MESSAGES)	Glossary 1	
Section I	Abbreviations	Glossary 1	
Section II	Display Abbreviations and Words	Glossary 2	
Section III	Target Type and Subtype Mnemonics	Glossary 20	
Section IV	Error Messages	Glossary 26	
	INDEX	Index 1	

HOW TO USE THIS MANUAL

This manual is divided into four chapters:

Chapter 1 contains an introduction to this manual and the Mortar Ballistics Computer Set M23.

Chapter 2 contains operating instructions for Mortar Ballistics Computer Set M23.

Chapter 3 contains operator maintenance instructions for Mortar Ballistics Computer Set M23.

Chapter 4 contains organizational maintenance instructions for Mortar Ballistics Computer Set M23.

Each chapter is indexed on the front cover and in the table of contents. Each chapter is divided into sections and each section is indexed in the table of contents. Each chapter title, the appendixes, the glossary, and the index are listed within a boxed area along the right hand edge of the front cover. The first page of each chapter includes an index of the major topics within the chapter, listed in order of appearance. All procedural steps are numbered to the left of the action required. The resulting display is shown to the right of the action.

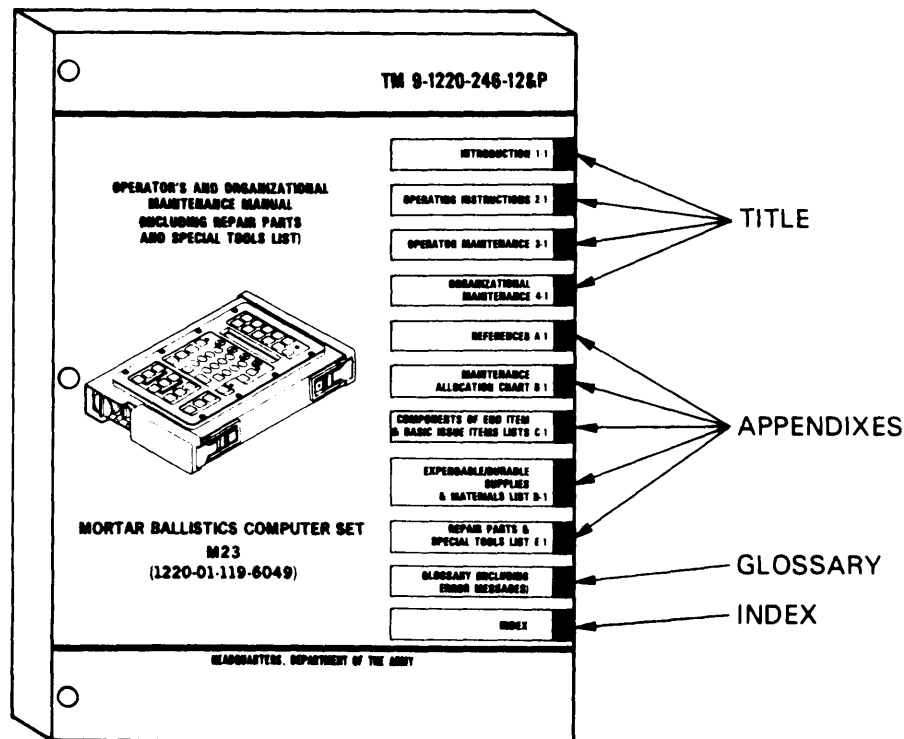

CHAPTER I

INTRODUCTION

	Page
General Information.	1-1
Equipment Description and Data	1-4
Principles of Operation.. . . .	1-11

Section I. GENERAL INFORMATION

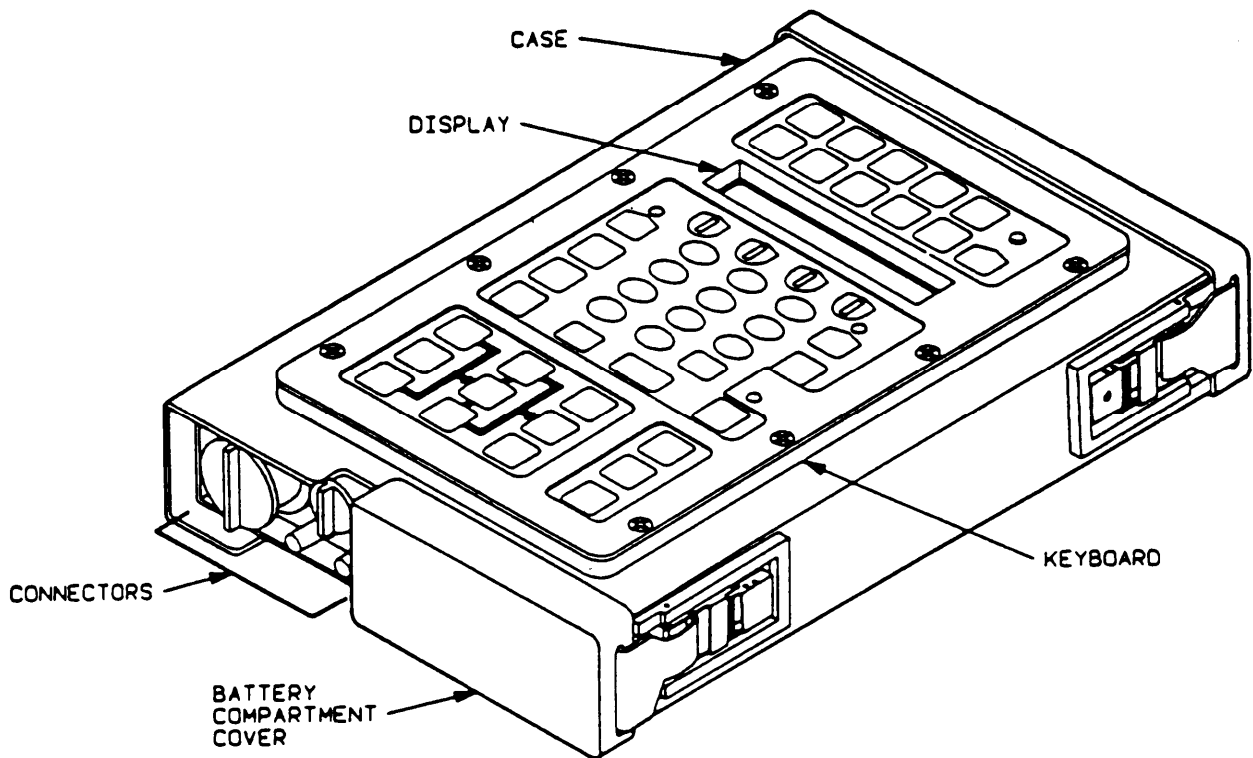

SCOPE

Type of Manual: Operator's and Organizational Maintenance Manual (Including Repair Parts and Special Tools List)

Model Number and Equipment Name: M23 Mortar Ballistics Computer Set (herein referenced as MBC Set)

Purpose of Equipment: To compute fire commands for 60 mm, 81mm, 107 mm, and 120mm mortars

MAINTENANCE FORMS, RECORDS, AND REPORTS

Department of Army forms and procedures used for equipment maintenance will be those prescribed by DA PAM 738-750, The Army Maintenance Management System (TAMMS).

REPORTING EQUIPMENT IMPROVEMENT RECOMMENDATIONS (EIR)

If your MBC needs Improvement, let us know. Send us an EIR. You, the user, are the only one who can tell us what you don't like about your equipment. Let us know why you don't like the design. Tell us why a procedure is hard to perform. Put it on an SF 368 (Quality Deficiency Report). Mail it to us at Commander, US Army Armament, Munitions, and Chemical Command, ATTN: AMSMC-QAD, Rock Island, IL 61299-6000.

DESTRUCTION OF ARMY MATERIEL TO PREVENT ENEMY USE

Destruction of electronics materiel to prevent enemy use shall be in accordance with TM 750-244-2.

PREPARATION FOR STORAGE OR SHIPMENT

Refer to Administrative Storage, Chapter 4.

NOMENCLATURE CROSS-REFERENCE LIST

This listing includes nomenclature cross-references used in this manual.
--

<u>COMMON NAME</u>	<u>OFFICIAL NOMENCLATURE</u>
AN/GRC-106 Interface Cable	Cable Assembly, Special Purpose, Electrical (CX-13150/GR)
Audio Interface CCA	Audio Interface
Battery Compartment Cover	Cover, Battery
Carrying Case	Case, Carrying
Chassis Assembly	Chassis, Electrical
Computer Case	Case, Computer
Display/Processor CCA	Circuit Card Assembly: Display
Field Case	Case, Computer, Ballistics
Keyboard	Keyboard, Data Entry
MBC	Computer, Ballistics: Mortar
MBC Set	Computer Set, Ballistics: Mortar M23
Memory CCA	Circuit Card Assembly: Memory
Modem CCA	Circuit Card Assembly: Memory
Power Supply	Power Supply Assembly
Primary Radio Interface Cable	Cable Assembly, Special Purpose, Electrical (CX-13151/PSG-2)
Security Screw Tool	Bit, Crosstip
Top Cover	Cover, Access
Vehicular Battery Cable	Cable Assembly, Special Purpose, Electrical (CX-13152/PSG-2)
Vehicular Receptacle Cable	Cable Assembly, Special Purpose, Electrical (CX-13148/PSG-2)

Section II. EQUIPMENT DESCRIPTION AND DATA

EQUIPMENT CHARACTERISTICS, CAPABILITIES, AND FEATURES

Characteristics.

- Lightweight
- Highly portable
- Battery-powered
- All weather operational
- Built-in self-test circuits
- Keep alive battery protects volatile memory during temporary power interruptions

Capabilities and Features.

- The MBC is capable of interoperation with the Digital Message Device (DMD) and Fire Support Team (FIST) DMD.
- MBC functions include
 - Reception and transmission of DMD messages.
 - Entering of Fire Direction Center (FDC) data.
 - Selection of mortar, location, and weapon type.
 - Computation of firing data.

LOCATION AND DESCRIPTION OF MAJOR COMPONENTS
--

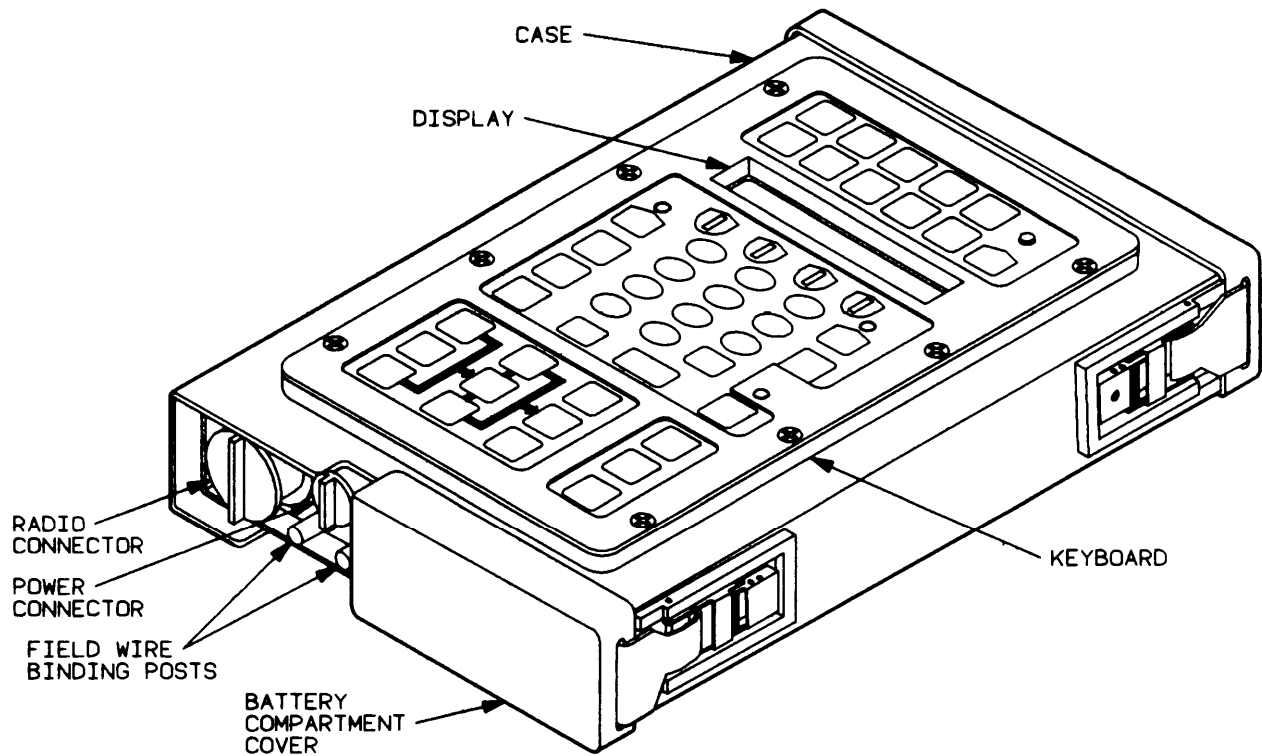

The MBC is housed in an aluminum case and consists of the following components:

Display. Maximum of 16 alphanumeric characters.

Case. Aluminum housing for MBC.

Keyboard. Allows data entry and fire mission processing.

Battery Compartment Cover. Provides access to battery compartment.

Field Wire Binding Posts. Allow field wire hookup to DMD.

Power Connector. Allows hookup to external 20-32 V dc.

Radio Connector. Allows hookup to AM or FM radio.

EQUIPMENT DATA

PHYSICAL MEASUREMENTS

MBC Weight with Battery with Battery and Cable Assembly	7.0 lb 8.0 lb
MBC Size Height	10.5 in.
Width	7.2 in.
Depth	2.3 in.

POWER REQUIREMENTS

External	20-32 V dc
Internal Mercury Battery, BA-1588/U	12 V dc
Lithium Battery, BA-5588/U	14 V dc
Ni-Cad Battery. BB-588/U	12 V dc
Ni-Cad (Keep Alive) Battery	4.8 Vdc

STORAGE SPECIFICATIONS

Message Type	Quantity
Fire Missions	3
Message Buffers	3
Weapons	18
Forward Observers	12
Known Points/Targets	50
Registration Points	16
Firing Sections	3
No Fire Zones	10
Final Protective Fire Lines	3
Safety Min-Max Charge Zones	3
Firing Section Solutions	6
No Fire Line	1
Points Per No Fire Area	8

EQUIPMENT DATA (CONT)

COMMUNICATIONS SPECIFICATIONS

Radio	Standard Army Radios
Wire	Two Wire Line Communications Equipment.
Bit Rate	600 or 1200 bps
Block Mode	Single or Double
Key Tone	0.2 to 4.0 sec

EQUIPMENT CONFIGURATION

CARRYING CASE ASSEMBLY

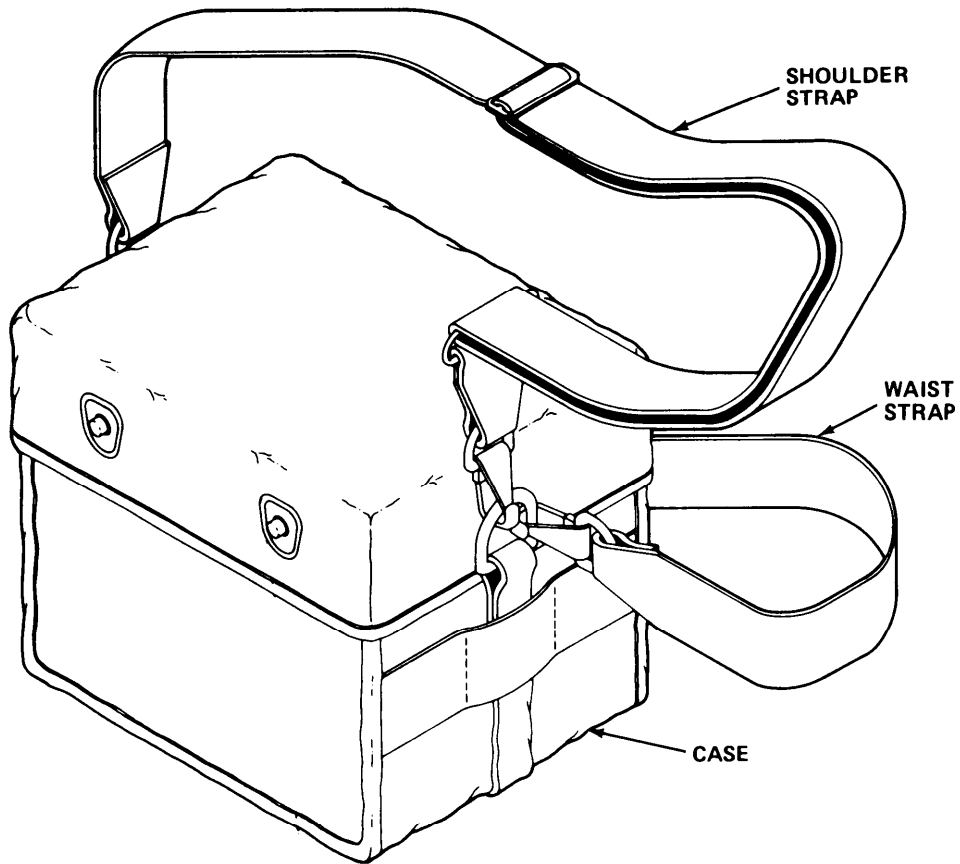

The carrying case consists of the shoulder strap, waist strap, and case.

EQUIPMENT CONFIGURATION (CONT)

CAUTION

Batteries should be stored and transported carefully to ensure that they are not accidentally discharged by shorting the connector pins.

Battery BA-5588/U.

- (Item 1, Appendix D)
- Lithium 14 V dc
- Intended for field use

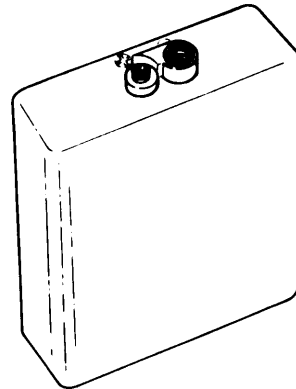

Battery BA-1588/U.

- Mercury 12 V dc
- Intended for field use

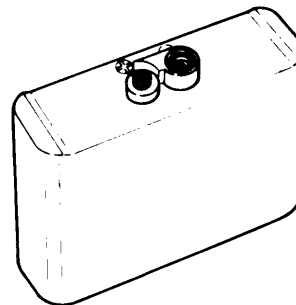

Battery BB-588/U.

- Rechargeable nickel-cadmium 12 V dc
- Intended for institutional training only
- To recharge, refer to procedures for type PP-7286/U battery charger in TM 11-6130-392-12.

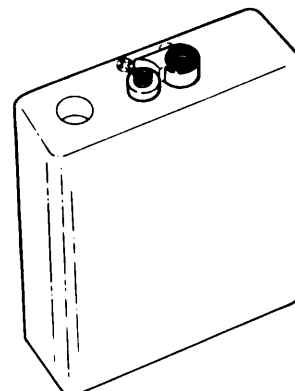

EQUIPMENT CONFIGURATION (CONT)

VEHICULAR RECEPTACLE CABLE

- 12-foot power cable
- Connects MBC to a vehicle 24/28-volt radio mount receptacle.

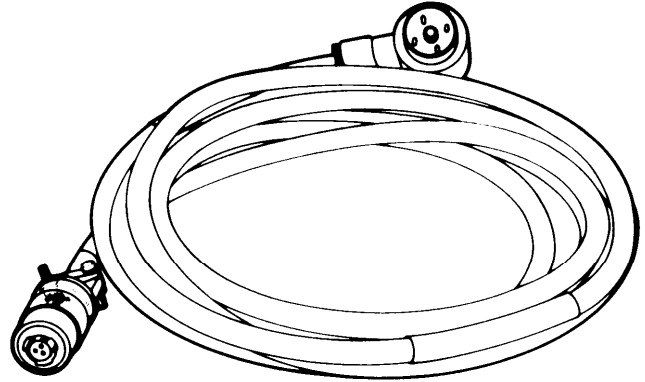

VEHICULAR BATTERY CABLE

- 12-foot power cable
- Connects MBC to a vehicle 24-volt battery.

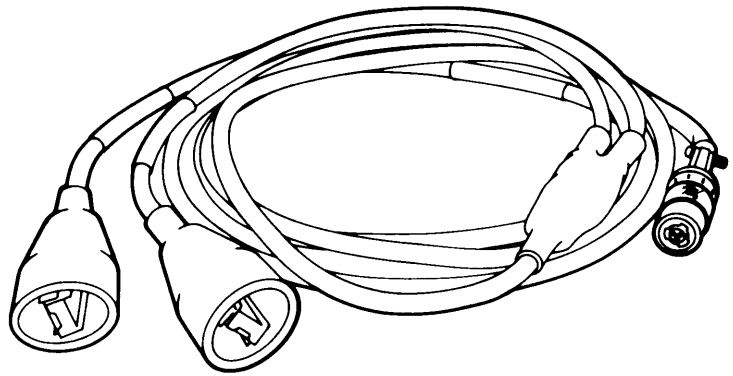

PRIMARY RADIO INTERFACE CABLE

- 8-foot audio cable
- Connects MBC to an FM radio set (VRC-12, PRC-77, GRC-160) and ancillary equipments GRA-39 and KY-38.

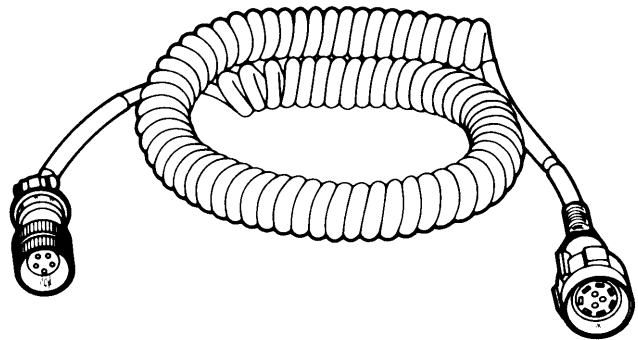

EQUIPMENT CONFIGURATION (CONT)

AN/GRC-106 INTERFACE CABLE

- 4-foot audio cable
- Connects MBC to AM radio set (GRC-106) and ancillary equipments GRA-6 and KY-8.

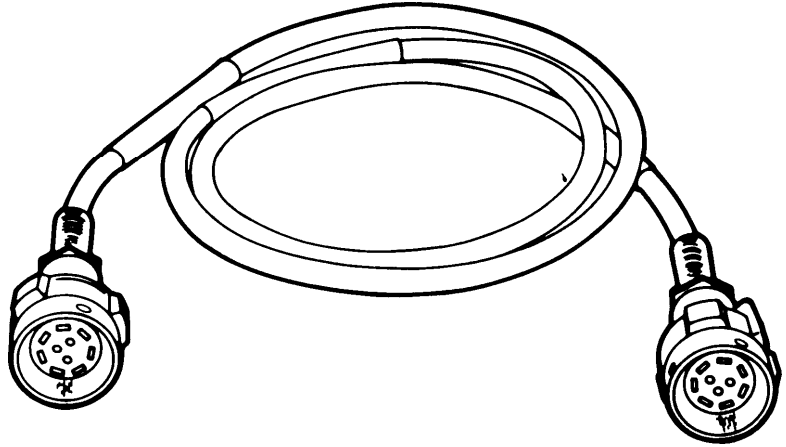

SAFETY, CARE, AND HANDLING

These rules apply to all MBC operating procedures. No damage will result from improper control settings. Follow the rules to keep your MBC in top condition.

- Do not use sharp objects to press keys and switches. Use only fingers; otherwise, serious damage can result to the MBC.
- During daylight, use lower display brightness level to save battery power.
- When removing or installing internal battery or external power connections, make sure MBC is turned off.

Section III. PRINCIPLES OF OPERATION

PURPOSE

The MBC requires fire mission data inputs to compute fire commands needed to effectively execute a mortar fire mission." When the MBC is connected to an external communication device, forward observer fire mission inputs are automatically entered and may then be reviewed and edited by the MBC operator. When the MBC is not connected to an external communication device, all fire mission data is entered manually by the MBC operator. The computed fire commands are then relayed by voice to the mortar crew.

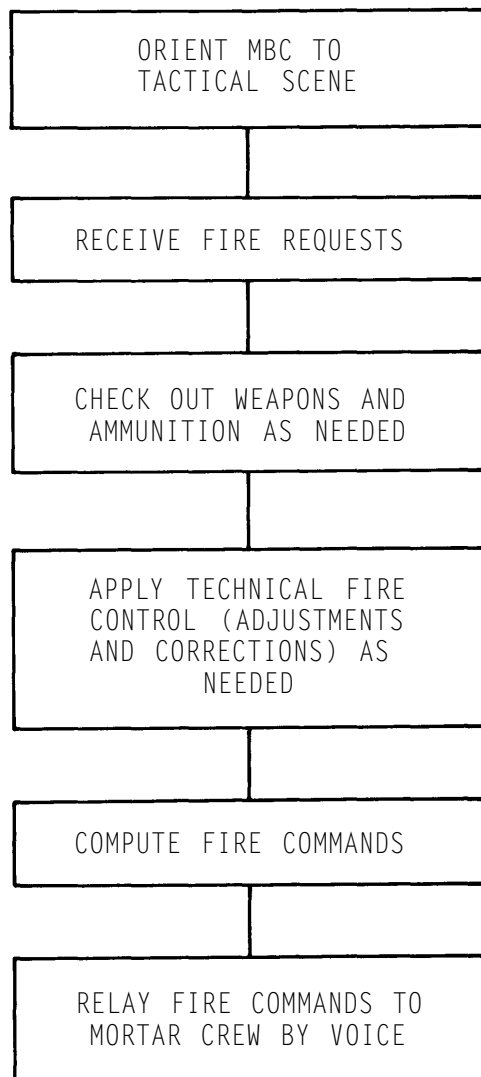
TYPICAL FIRE MISSION
by the MBC operator

CHAPTER 2
OPERATING INSTRUCTIONS

	Page
Description and Use of Operator's	
Control and Indicators	2-1
Operator Preventive Maintenance	
Checks and Services (PMCS)	2-21
Operation Under Usual Conditions	2-24
Operation Under Unusual Conditions	2-159

Section I. DESCRIPTION AND USE OF OPERATOR'S
CONTROLS AND INDICATORS

GENERAL

The illustration below is an overview of the groupings of controls and indicators.

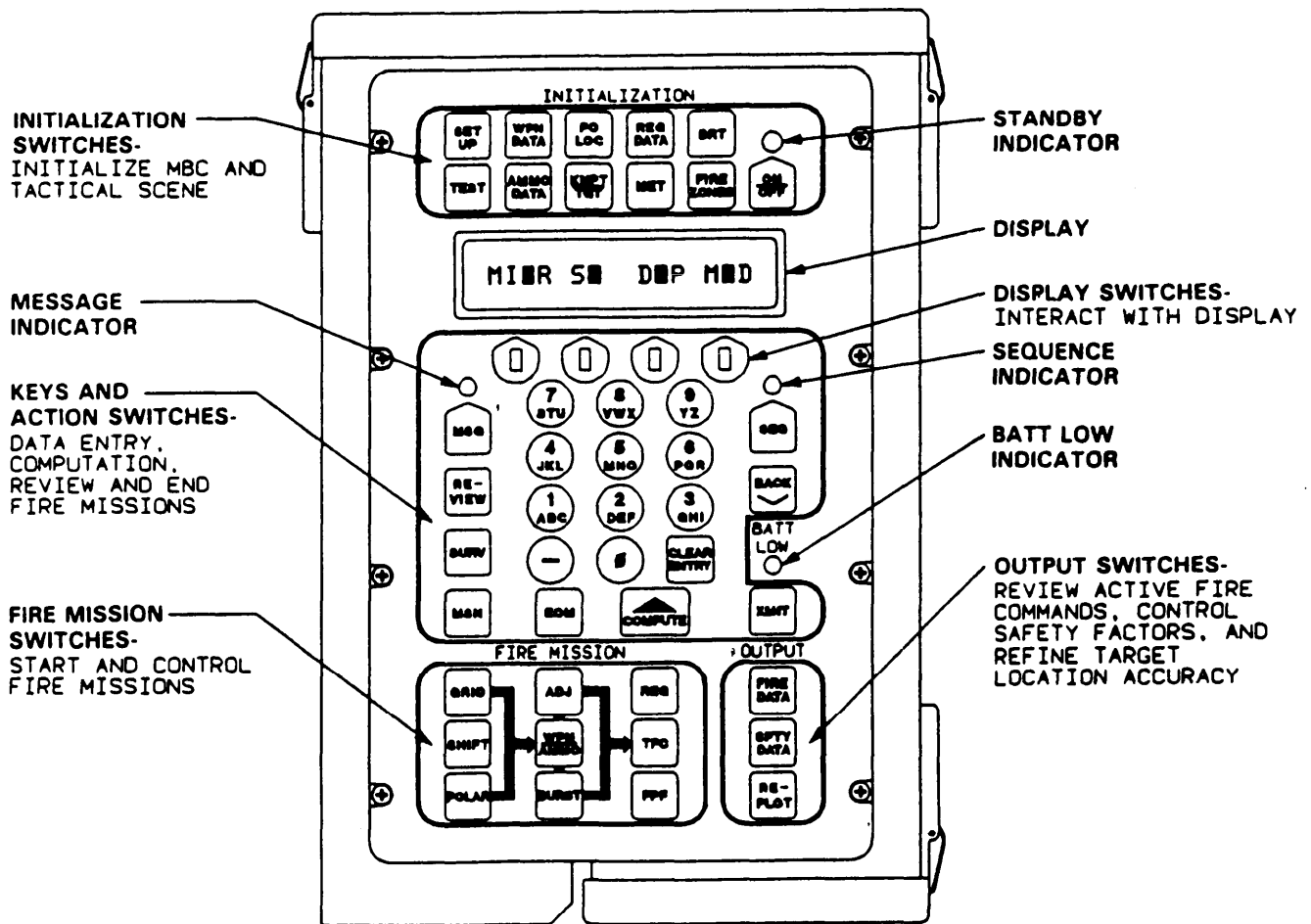

CONTROLS AND INDICATORS

INITIALIZATION SWITCHES

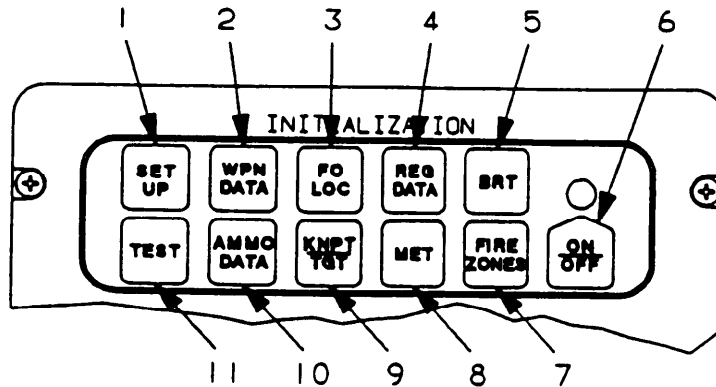

Key	Control or Indicator	Function
1	SET UP switch	Starts menus for entry of setup data: timeout, target prefix and block number range, location grid declination, message transmission rate, transmitter warmup delay time, single or double block mode, and owner identification.
2	WPN DATA switch	Starts menus for entry of weapon data for each unit: Location of base piece, and individual weapon locations. selects tube type for 81MM shell(M29 or M252).
3	FO LOC switch	Starts menus for entry of forward observer (FO) data: FO number, location, and altitude.
4	REG DATA switch	Starts menus for manually entering a registration data file for registration points (RP) or review of RP data: Renumber, location, altitude, weapon unit and number, elevation for 107mm or charge for 60/81/120mm, type of MET data used when RP was fired, and range and deflection correction factors.

CONTROLS AND INDICATORS (CONT)

Key	Control or Indicator	Function
5	BRT switch	Selects level of brightness for display area. Controls keyboard background lighting.
6	ON/ OFF switch	Turns MBC on or off. When turned on, display momentarily shows POWERUP TEST, then shows READY.
7	FIRE ZONES switch	Starts menus for entry of fire zone boundaries/ fire lines (fire areas): location points for fire lines; zone number, number of points for fire zone (no fire area), and location points for fire zone boundaries.
8	MET switch	Starts menus for entry of non-standard MET: MET station data and location, and entry of nine lines of MET data including wind direction, speed, temperature, and pressure for each line of MET data.
9	KNPT/ TGT switch	Starts menus for data entry of known points or target points: known point or target number, location, and altitude.
10	AMMO DATA switch	Starts menus for entry of ammunition data for each caliber weapon in use: ammunition types, powder temperature change, and correction factors for projectile weight.
11	TEST switch	Manually starts Self-Test of: Microprocessor (ROM, RAM, and instruction set), all switches and keys, display (character generation), modem (communication device), software revision number, and communications (transmit test message).

CONTROLS AND INDICATORS (CONT)

ACTION SWITCHES

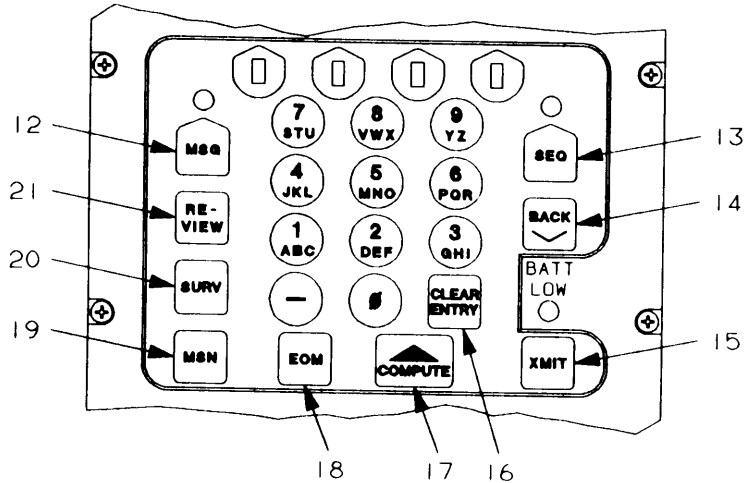

Key	Control or Indicator	Function
12	MSG switch	Displays first line of a message transmitted by a digital message device (DMD) or fire support team (FIST) DMD.
13	SEQ switch	Displays next line of menu to allow viewing or entry of data. Data entered from keyboard is not stored in memory until the SEQ switch is pressed.
14	BACK switch	Displays previous menu line to allow reviewing or data changes (back-sequence through data).
15	XMIT switch	Starts message to observer (MTO) menus or command message to observer (CMD) menus for entry and transmission of firing information to the observer.
16	CLEAR ENTRY switch	Removes last (rightmost) character from a data field. Allows rekeying for an entry.

CONTROLS AND INDICATORS (CONT)

Key	Control or Indicator	Function
17	COMPUTE switch	Starts computation of fire mission data, survey data, registration data, and adjustments.
18	EOM switch	Starts menus for manual entry of end-of-mission instructions: to delete all mission data or end the active mission and store the final target location in the target file.
19	MSN switch	Starts menus to review current fire mission data and to assign a mission number (making the mission operational).
20	SURV switch	Starts menus for manual entry of survey data for computation. Survey types are resection, intersection and traverse. Data entries are horizontal and vertical angles, and distances. Computed answer may be stored as a known point, target point, FO location, or base piece location.
21	REVIEW switch	Returns display to first line of a message or to main menu currently in use.

CONTROLS AND INDICATORS (CONT)

KEYS

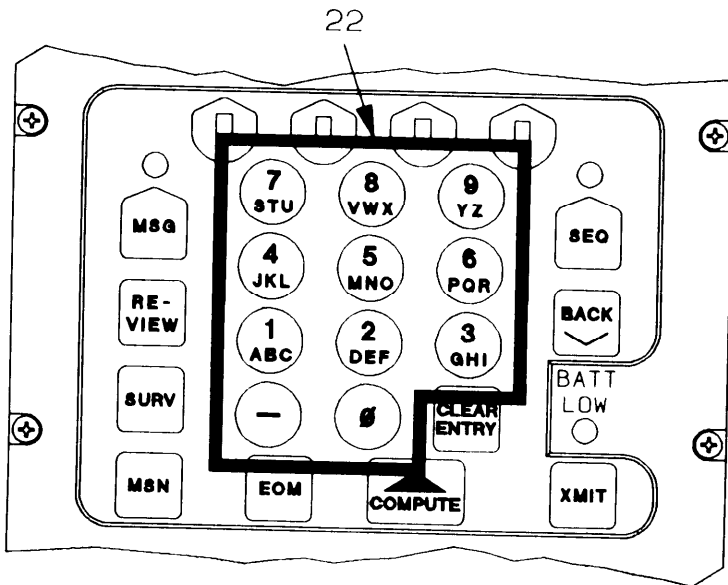

Key	Control or Indicator	Function
22	keys	Eleven keys used to enter alpha or numeric characters and minus sign. Alpha or numeric selection for combination keys is either automatic or menu-selectable.

FIRE MISSIONS

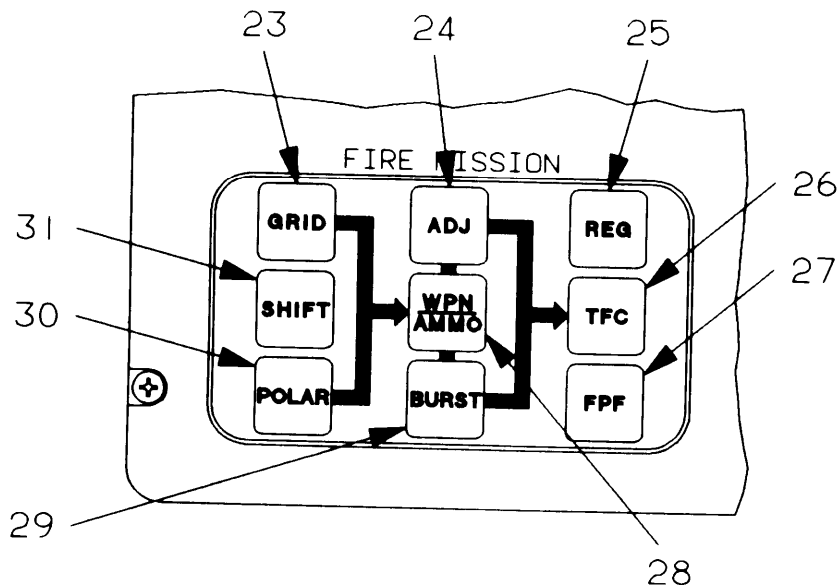

CONTROLS AND INDICATORS (CONT)

Key	Control or Indicator	Function
23	GRID switch	Starts menus for manual entry of grid fire mission data when target location is identified by grid coordinates. Entries are: FO ID number, FO direction to weapon, target location, and altitude when known.
24	ADJ Switch	Starts menus for manual entry of fire mission adjustment data (corrections) from the FO. By menu selection use registration point data or MET data. Correction entries are: left or right deviation, plus or minus range, and up or down height.
25	REG switch	Starts menus for review of registration data, and computation and storage of registration point correction factors. Displayed output from computation includes range correction factor and deflection amount.
26	TFC switch	Starts menus for manual entry of technical firing data. Used to enter or change information for sheaf, method of control, weapons to fire, and use registration point data or type of MET data.
27	FPF switch	Starts menus to manually enter final protective fire line data, safety fan, and minimum/maximum charge. Entries are FPF location, target altitude, target width, and attitudes
28	WPN/ AMMO switch	Starts menus to manually enter or change weapon or ammunition data for afire mission. Entries are weapon unit and number, shell fuze combination, charge (60/81/120mm) or elevation (107mm).
29	BURST switch	Starts menus for manual entry of burst location data (corrections) supplied by a laser-equipped FO. Entries, from laser to burst, are direction, distance, and vertical angle.
30	POLAR switch	Starts menus for manual entry of either a normal or laser polar fire mission using polar plot data. A normal polar mission target is identified by direction, distance, and up/down height from an FO. A laser polar mission target is identified by laser direction, distance, and vertical angle.
31	SHIFT Switch	Starts menus for manual entry of shift fire mission data when target location is identified by a shift from an existing known/target point. Entries are FO IO, known/-target point number, FO direction to target, and direction and amount of shift.

CONTROLS AND INDICATORS (CONT)

OUTPUT SWITCHES

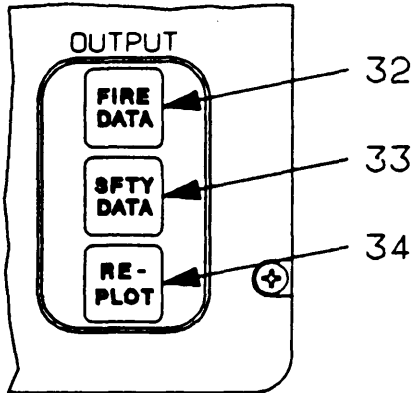

Key	Control or Indicator	Function
32	FIRE DATA Switch	Starts menus for reviewing existing fire commands of active fire missions. Data is same as the COMPUTE switch output.
33	SFTY DATA switch	Starts safety data menus for an active fire mission to review safety factors, enter boundaries for a safe firing area, or enter a minimum and maximum charge for the safety area.
34	REPLOTT Switch	Starts menus to review target replot data and to increase target location accuracy. Enter new target altitude then press REPLOTT switch to compute a new grid location.

CONTROLS AND INDICATORS (CONT)

DISPLAY SWITCHES

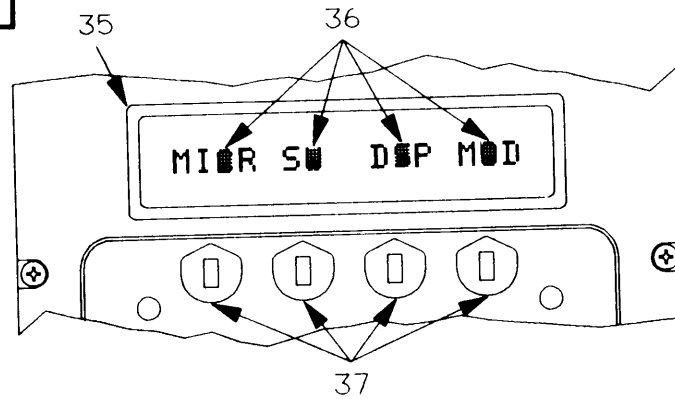

Key	Control or Indicator	Function
35	display area	Displays maximum of 16 alphanumeric characters.
36	flashing character blocks (4)	Signal need for operator action. Either press the display switch (key 37) below the flashing block or press the SEQ switch to respond. Any combination of blocks (or none) may flash.
37	display switches (1 thru 4, left to right)	Relate to each flashing character block (key 36). A display switch is active when the character block above is flashing. Use to bring additional data to the display, change display entries, or make selections from the display.

CONTROLS AND INDICATORS (CONT)

LED INDICATORS

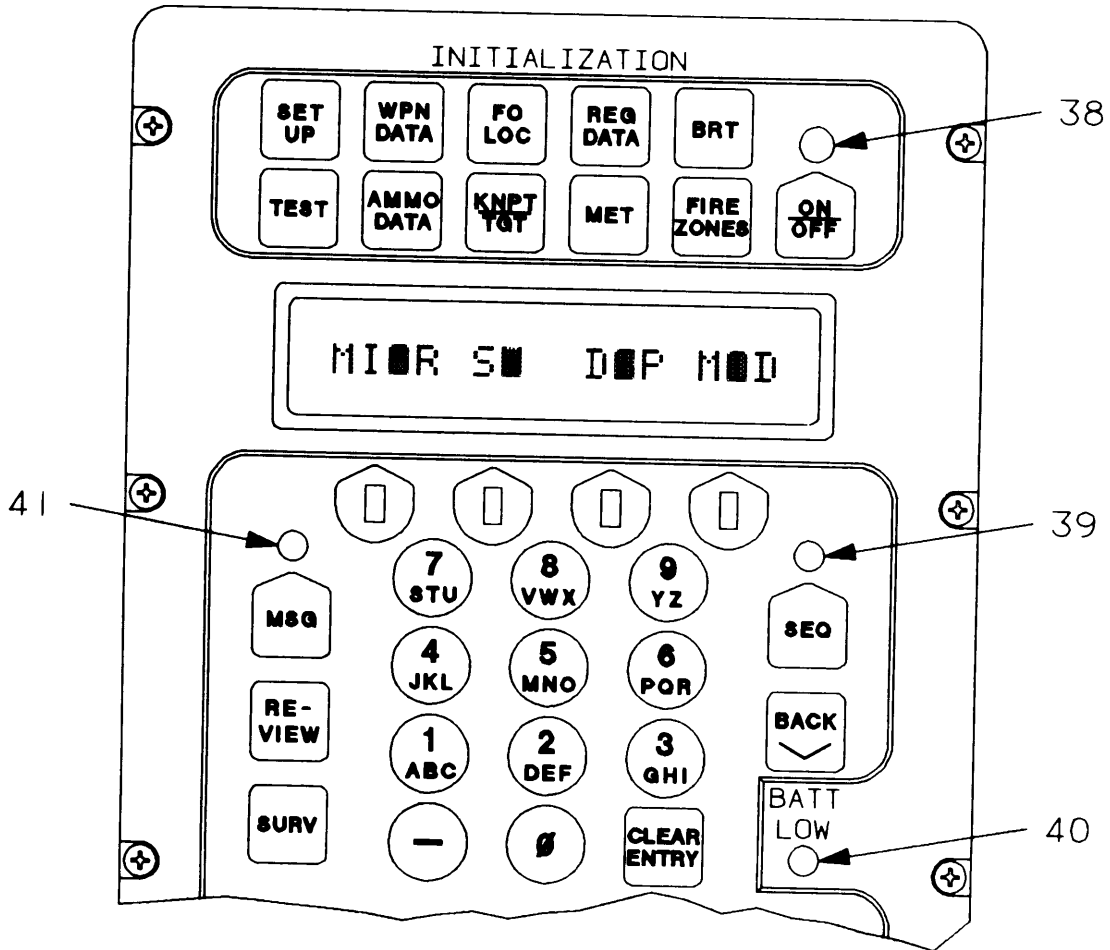

CONTROLS AND INDICATORS (CONT)

Key	Control or Indicator	Function
38	standby indicator (LED)	Indicates display timeout period has expired (when flashing). Flashes once every 6 seconds while display is timed out. Stays on approximately 0.5 seconds. Press any switch to refresh display.
39	sequence indicator (LED)	Indicates more data is available for the current menu (when flashing). Flash rate: 1.25 times-per-second.
40	BATT LOW indicator (LED)	Indicates 12 volt battery voltage is low (when flashing). Starts flashing at 11 volts. MBC shuts off at 10 volts. Flash rate: 1.25 times-per-second at 11 volts or less.
41	message indicator (LED)	Indicates MBC has received up to three digital messages (when flashing). Flash rates indicate number of messages received. Flash rate: <ul style="list-style-type: none"> 1) 1.25 times-per-second, one message 2) 2.5 times-per-second, two or more messages 3) 5 times-per-second, one or more FO CMD messages
--	audio alarm	Internal alarm beeps continuously when digital messages are received. Beep rate for an FO command message is noticeably faster than rate for other message types. Turn off beeping alarm by pressing any switch or key. Alarm ON/OFF function is menu-selectable in the SET UP switch.

DATA ENTRY

GENERAL

LEARN THE FOLLOWING SWITCH ACTION EXPLANATIONS

DISPLAY SWITCHES-

To represent display - display switch interaction in this manual:

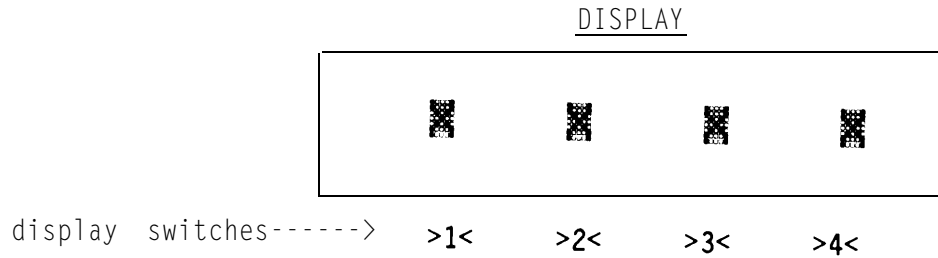

X represents displayed data within a flashing block.
 Numbers >1<, >2<, >3<, and >4< represent the display switches, from left to right, that can select or change the data displayed in the associated flashing block.

Use display switches to

- Bring additional data to display for viewing
- Change display entries
- Make selections from display

The different types of MBC data entry are

- DEFAULT
- ALPHA
- NUMERIC
- CORRECTION
- DIRECTION
- MULTIPLE CHOICE

The following examples use only the SET UP switch menus to demonstrate each type of data entry listed above. These data entry examples do, however, apply to all switches. Practice the following examples until each type of data entry is mastered.

DATA ENTRY (CONT)

NOTE

The data used is sample data intended for illustration purposes only.

DISPLAY

- 1 Press ON/OFF switch to turn on MBC. The display momentarily shows :

POWERUP TEST

then shows:

READY

DEFAULT ENTRY

- 2 Press SET UP switch.
A timeout period of 15 seconds is computer-assigned (a default entry).

TIME OUT: 15

ALPHA ENTRY - by menu selection

- 3 Press SEQ switch.
(Fill in the underlined blanks.) Use keyboard to enter target prefix, for example AH, as follows.

TGT PRFX: _

DATA ENTRY (CONT)

DISPLAY

4 Press 1/ABC key.

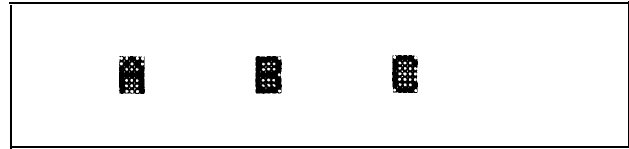

display switch >1<

5 Press display switch 1 to select A.

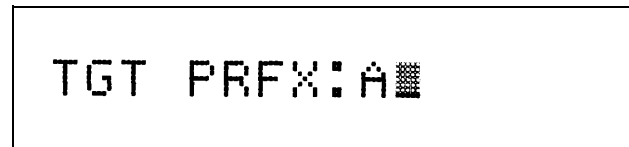

6 Press 3/GHI key.

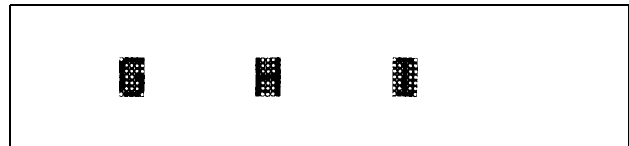

display switch >2<

7 Press display switch 2 to select H.

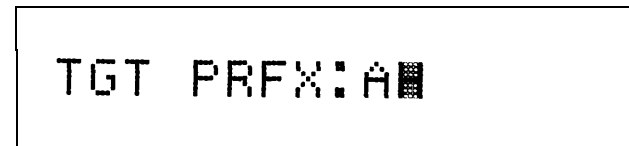

NUMERIC ENTRY - directly from keyboard

8 Press SEQ switch.

(Fill in the underlined blanks.)
 Use keyboard to enter numeric target block number range, for example 0001 and 9999. Leading zeros must be entered.

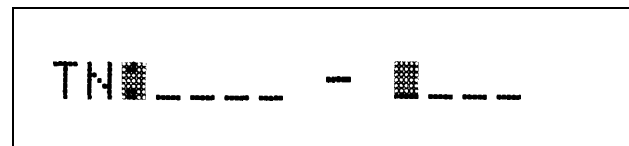

DATA ENTRY (CONT)

DISPLAY

- 9 Press 0 key three times.
Press 1/ABC key.
Press 9/YZ key four times.

TN0001 - 9999

CORRECTION ENTRY - clearing rightmost character

- 10 To change 9999 to 9995 press CLEAR ENTRY switch, clearing the rightmost character.

TN0001 - 999_

- 11 Press 5/MNO key.

TN0001 - 9995

display switches >1<

>3<

CORRECTION ENTRY - clearing entire field

- 12 The flashing blocks above display switches 1 and 3 indicate that both fields may be changed. To change 9995 to 8000 press display switch 3 to clear the entire field.

TN0001 - 8_ _ _

- 13 Press 8/VWX key.
Press 0 key three times.

TN0001 - 8000

- 13.1 Press SEQ switch.

ALARM: OFF

- 13.2 Turns ON/OFF. ALARM sounds when message received from DMD or safety violation occurs.



DATA ENTRY (CONT)

DISPLAY

14 Press SEQ switch two times, while advancing to the minimum Easting and Northing displays. Three trailing zeros are computer-entered for each.

MIN E: ___000

15 Use 050 for each display.
Press 0 key.
Press 5/MNO key.
Press 0 key.

MIN E: 050000

16 Press SEQ switch.

MIN N: ___000

17 Press 0 key.
Press 5/MNO key.
Press 0 key.

MIN N: 050000

DIRECTION ENTRY - display selectable

18 Press SEQ switch. This display is one example of a direction entry with an amount. East (E) or West (W) must be selected from the display before filling in the underlined blanks for grid declination. For this example select E and enter 10 as follows:

■ ■ GD ---

>1< display switch

DATA ENTRY (CONT)

DISPLAY

19 Press display switch
1 to select E.



20 Press 1/ABC key.
Press 0 key.



NOTE

Additional direction indicators found in menus are:

<u>Indicator</u>	<u>Definition</u>	<u>Indicator</u>	<u>Definition</u>
H	Horizontal	S	Slant
L	Left	R	Right
U	up	D	Down
+	Add	-	Drop
+	North	-	South

DATA ENTRY (CONT)

MULTIPLE CHOICE ENTRY

DISPLAY

- 21 Press the SEQ switch four times while advancing to the keytone menu. Some displays show as many as four selections with additional selections to be viewed. For this example change keytone to 3.5 as follows.

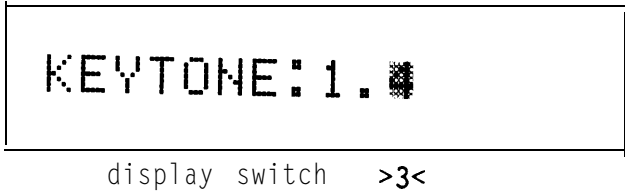

- 22 Press display switch 3, rejecting default and bringing additional selections into view. (Keytone 3.5 not yet shown)

NOTE

Sequence indicator flashes indicating additional selections to be viewed.

- 23 Press SEQ switch bringing additional selections to display. (Sequence indicator is off.)

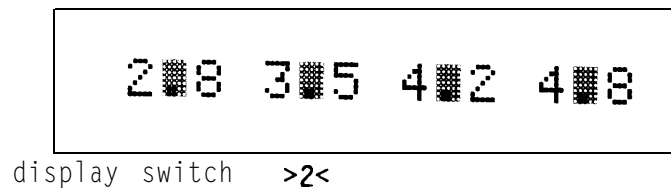

- 24 Press display switch 2 to select 3.5.

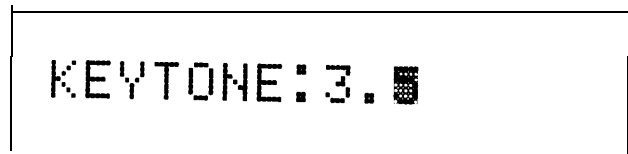

DATA ENTRY (CONT)

DISPLAY

25 Press SEQ switch.

BLK:SN

CORRECTION ENTRY - by menu selection

26 For this example go back to the keytone menu and change keytone from 3.5 to 2.8. Press BACK switch to return to keytone menu.

KEYTONE:3.5

display switch >3<

27 Press display switch 3.

02 07 14 21

28 Press SEQ switch.

28 35 42 48

display switch >1<

29 Press display switch 1 to select 2.8.

KEYTONE:2.8

DATA ENTRY (CONT)

RETURN TO READY DISPLAY

DISPLAY

30 Press SEQ switch two times entering 2.8 and applying SNG BLK default while advancing to the last fill-in-the-blank menu in SET UP switch.

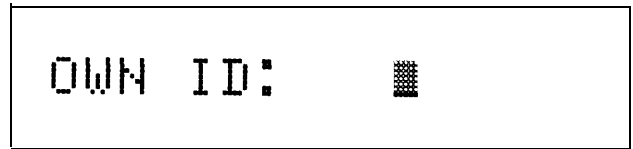

31 Enter owner ID A thru Z or 0 thru 9. For this example enter digit 1 for owner ID. Press 1/ABC key.

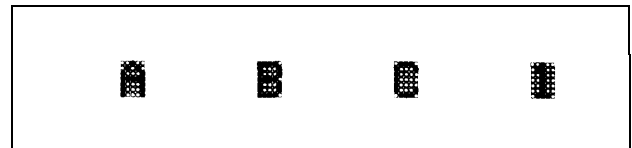

display switch >4<

32 Press display switch 4.

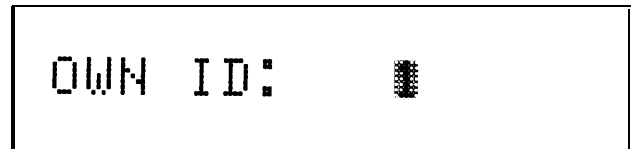

33 Press SEQ switch.

The MBC is waiting for another switch activation.



To repeat these examples press SET UP switch and proceed with DEFAULT ENTRY.

34 Press ON/OFF switch to turn off MBC.

Section II. OPERATOR PREVENTIVE MAINTENANCE CHECKS AND SERVICES (PMCS)

GENERAL

Before you operate. - Always keep in mind the CAUTIONS and WARNINGS. Perform your before mission (B) PMCS. You should perform your (B) PMCS if your are operating the MBC for the first time.

While you operate. - Always keep in mind the CAUTIONS and WARNINGS. Perform your during mission (D) PMCS.

After you operate. - Be sure to perform your after mission (A) PMCS.

If your equipment fails to operate. - Troubleshoot with proper equipment. Report any deficiencies using the proper forms. Refer to DA PAM 738-750.

PMCS PROCEDURES

Routine checks such as cleaning and inspecting stored accessories not in use are not listed in your PMCS. Do these procedures anytime you see that they must be done. If you find a routine check like one of those listed in your PMCS table, it is listed because others reported trouble with this item.

- When MBC is packed in limited storage, it requires PMCS monthly.
- Your PMCS table lists the inspections and care required to keep your equipment in good operating condition.
- The item number column is a source of item numbers for the TM number column on DA Form 2404, Equipment Inspection and Maintenance Worksheet., in recording results of PMCS.
- The interval column of your PMCS table tells you when to do a certain check or service.
- The procedure column of your PMCS table tells you how to do the required checks and services. Carefully follow these instructions. If you do not have the tools, or if the the procedure tells you to, have organizational maintenance do the work.
- If your equipment does not perform as required, refer to Chapter 3 under Troubleshooting Procedures. Report any malfunctions or failures on the proper DA Form 2404, or refer to DA PAM 738-750.
- The equipment is not ready/available if: column of your PMCS table tells you when and why your equipment cannot be used.

PMCS PROCEDURES (CONT)

Operator/Crew Preventive Maintenance Checks and Services

NOTE: Within designated interval, these checks are to be performed in the order listed.

Item No.	Interval			Items to be Inspected	Procedures Check for and have repaired or adjusted as necessary	Equipment is Not Ready/ Available if:
	B - Before	D - During	A - After			
1	*		*	MBC	Inspect MBC for completeness.	Any item required to support the unit mission is missing.
2	*	*		MBC exterior surfaces	Check for dust, dirt, and moisture on display, keyboard, and exterior surfaces.	Buildup on controls, indicators, or display makes operation or battery replacement impossible.
3	*	*	*	Battery	Check for swelling and corrosion. Remove when not in use for more than 30 days.	Battery is defective.
4	*	*	*	Battery compartment cover	Check for cracks, warped cover, and condition of rubber gasket and straps.	Cover does not close or straps are broken.
5	*			Battery compartment	Check for dirt in connector or broken connector.	Connector is dirty or broken.
6	*			Controls and indicators	Perform Self-Test to make sure that controls and indicators function.	Self-Test cannot successfully be completed.

PMCS PROCEDURES (CONT)

Operator/Crew Preventive Maintenance Checks and Services

NOTE : Within designated interval, these checks are to be performed in the order listed.

Item No.	Interval			Items to be Inspected	Procedures Check for and have repaired or adjusted as necessary	Equipment is Not Ready/ Available if:
	B - Before	- During	A - After			
7	*	*	*	Display	While performing Self-Test, make sure display window is free of heavy scratches that would change appearance of characters. Inspect display window for signs of cracks or other damage that would allow entry of moisture.	Display window is damaged. Display window is damaged.
8	*	*	*	Latches	Check that all latches can close.	Latches will not close.
9	*	*	*	Keyboard	Check to see that surface is clean and not damaged.	Keyboard is punctured or damaged.
10	*		*	Plugs and connectors	Inspect all external plugs and connectors for damaged pins, breakage, firm seating, and missing or damaged dustcovers.	Mission requires use of damaged plugs and connectors.
11	*		*	Cables and connectors	Check cables for damaged insulation, pins, and connectors.	Mission requires use of cable showing damage.

Section III. OPERATION UNDER USUAL CONDITIONS

ASSEMBLY AND PREPARATION FOR USE

The particular mission of the MBC will determine the assembly of the accessories at the beginning and during the mission. Communication and power connections will be made in accordance with instructions given by your supervisor before you operate the MBC.

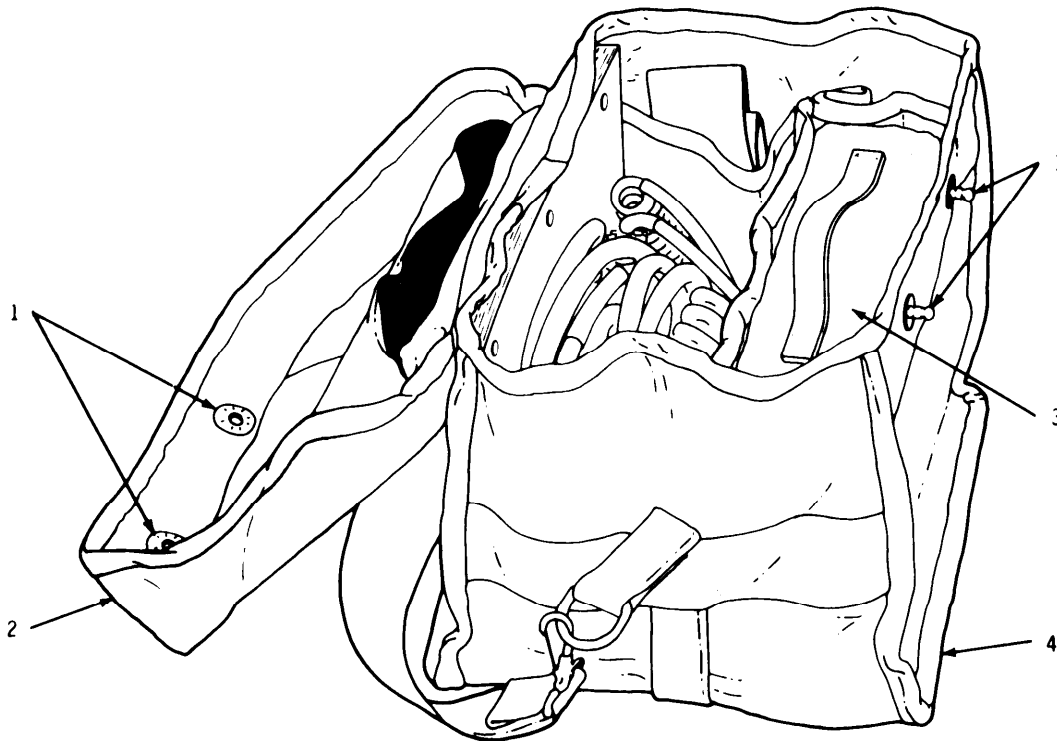

1 Unsnap two carrying case fasteners (1) and open flap (2).

2 Lift MBC (3) from carrying case (4).

ASSEMBLY AND PREPARATION FOR USE (CONT)

BATTERY REPLACEMENT

NOTE

Battery replacement may be performed by partially opening the field case.

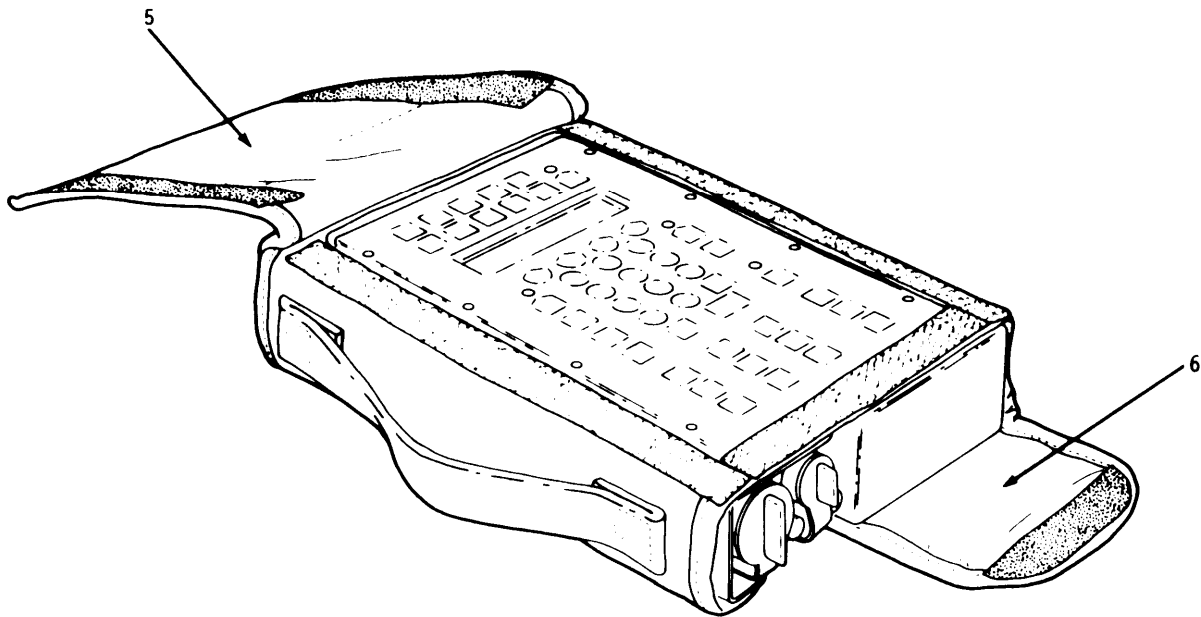

3 Open field case top flap (5) and battery end flap (6).

ASSEMBLY AND PREPARATION FOR USE (CONT)

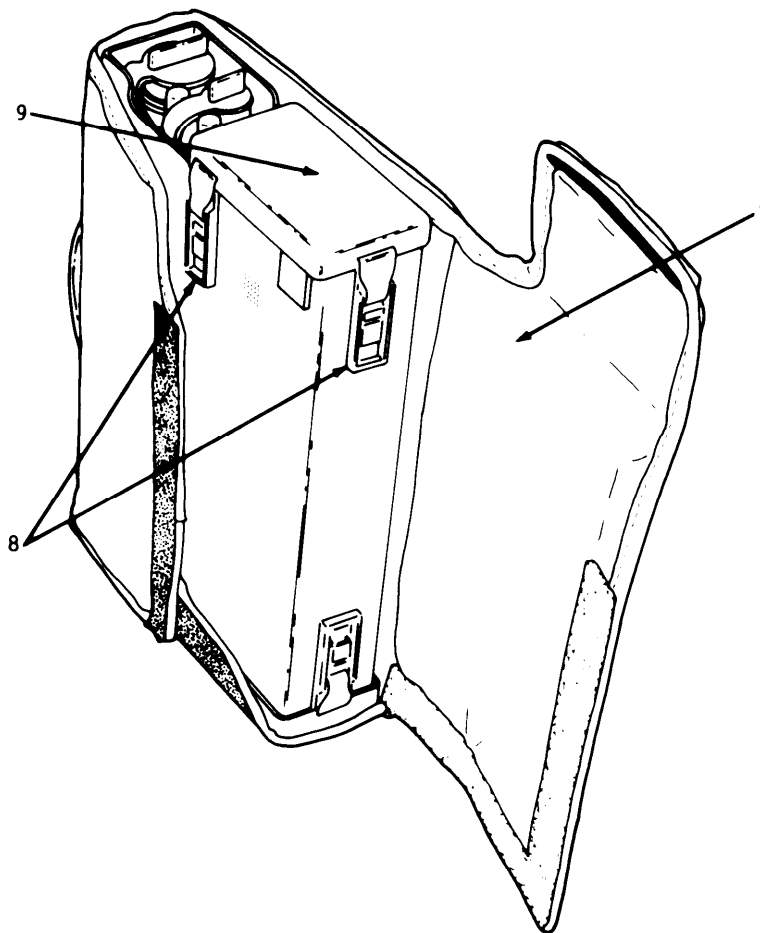

4 Open bottom flap (7), release two battery compartment cover latches (8), and lift battery compartment cover (9).

NOTE

If battery had been previously installed, lift battery compartment cover (9) away from MBC until battery removal straps pull battery free of connector.

WARNING

Lithium organic batteries are used in this equipment. Do not heat, burn, crush, puncture, disassemble, or otherwise mutilate the batteries. Failure to observe this warning could result in personal injury.

ASSEMBLY AND PREPARATION FOR USE (CONT)

NOTE

Position MBC with keyboard up while installing battery (10). This allows proper positioning of battery removal straps (11).

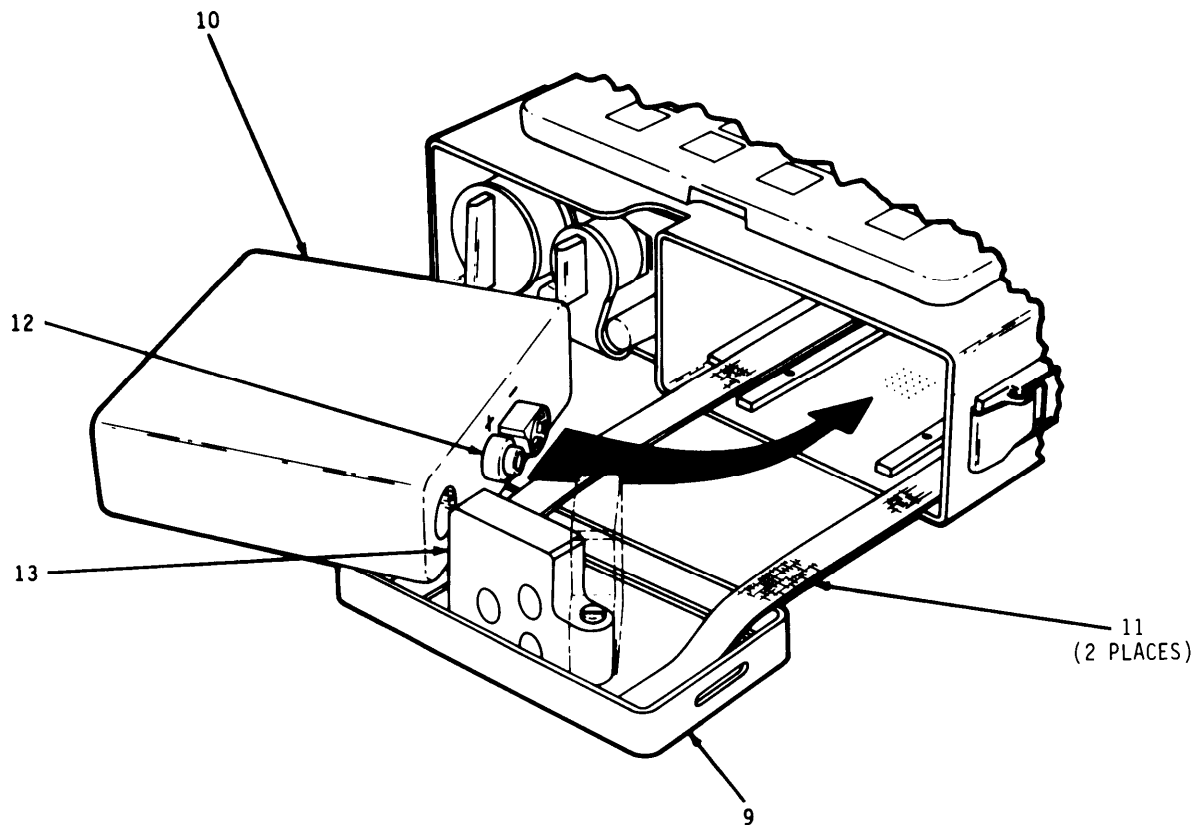

5 Insert battery (10) with connectors (12) as shown.

6 If short mercury battery type BA-1588/U is used, position spacer (13) as shown (in dashed lines).

ASSEMBLY AND PREPARATION FOR USE (CONT)

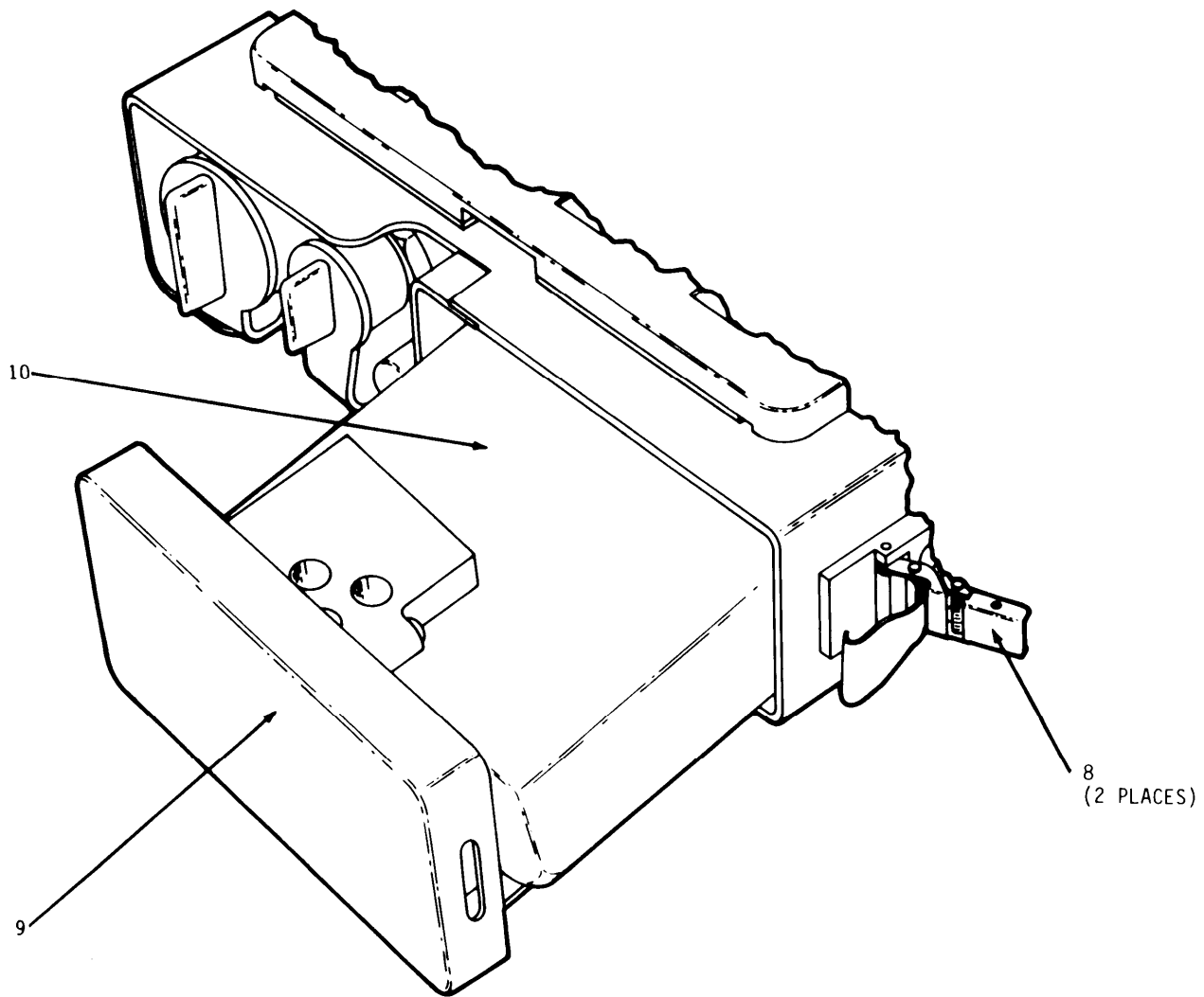

7 Push battery (10) into compartment.

8 Position battery compartment cover (9) and close latches (8).

ASSEMBLY AND PREPARATION FOR USE (CONT)

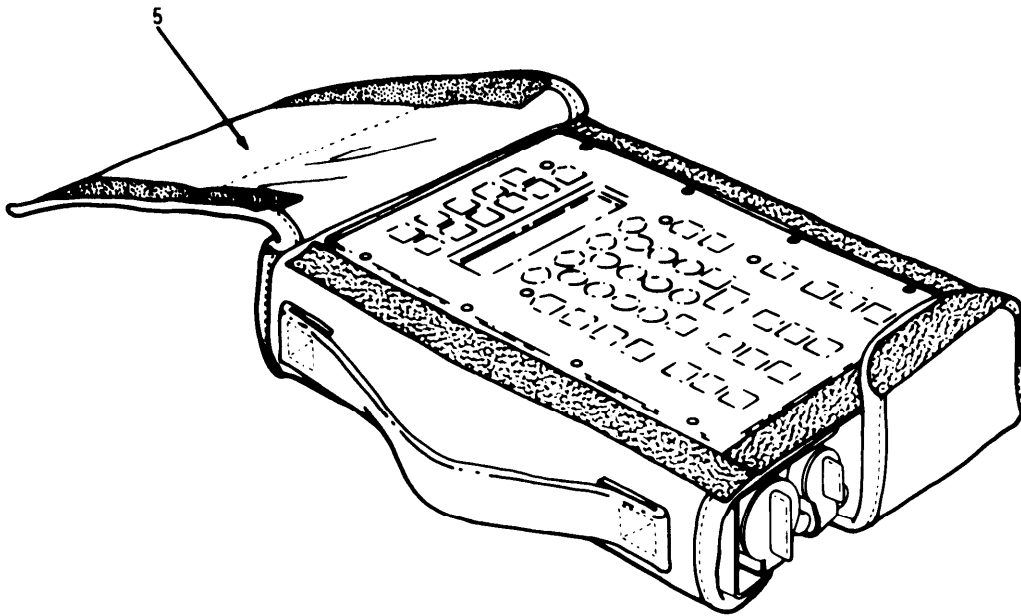

9 Close all flaps except top flap (5).

NOTE

Always keep MBC in field case to provide full protection during operation. The field case design allows full, easy access to the keyboard, battery compartment, and external connections.

ASSEMBLY AND PREPARATION FOR USE (CONT)

EXTERNAL POWER CONNECTIONS

CAUTION

Do not connect MBC to external power, and do not start vehicle engine with MBC turned on. Make sure MBC ON/OFF switch is turned off. DISREGARDING THIS CAUTION COULD CAUSE EQUIPMENT DAMAGE.

NOTE

The MBC may be powered from either of two different external 24-volt power sources, vehicle radio mount receptacle or vehicle battery.

If using vehicular receptacle cable, perform steps 10 through 12.

If using vehicular battery cable, perform steps 13 through 16.

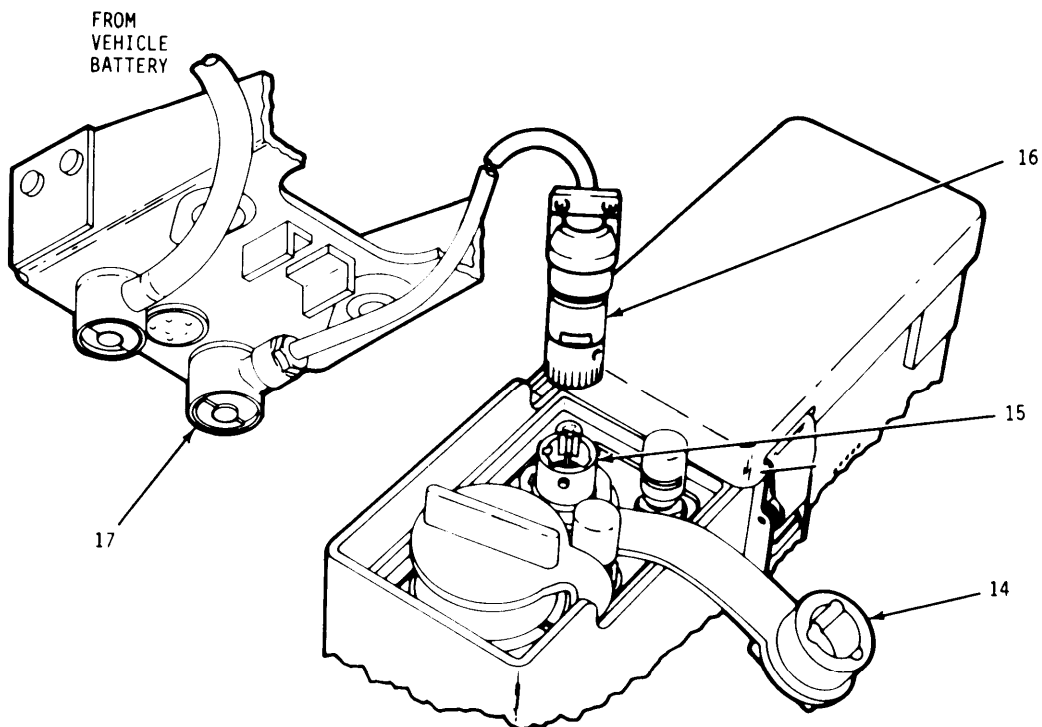

- 10 Pull dustcover (14) from MBC power connector (15).
- 11 Connect vehicular receptacle cable plug labeled DMD (16) to MBC power connector (15).
- 12 Connect cable plug labeled POWER (20-32 VDC) VEHICULAR RECEPTACLE (17) to vehicle 24/28 volt radio mount receptacle.

ASSEMBLY AND PREPARATION FOR USE (CONT)

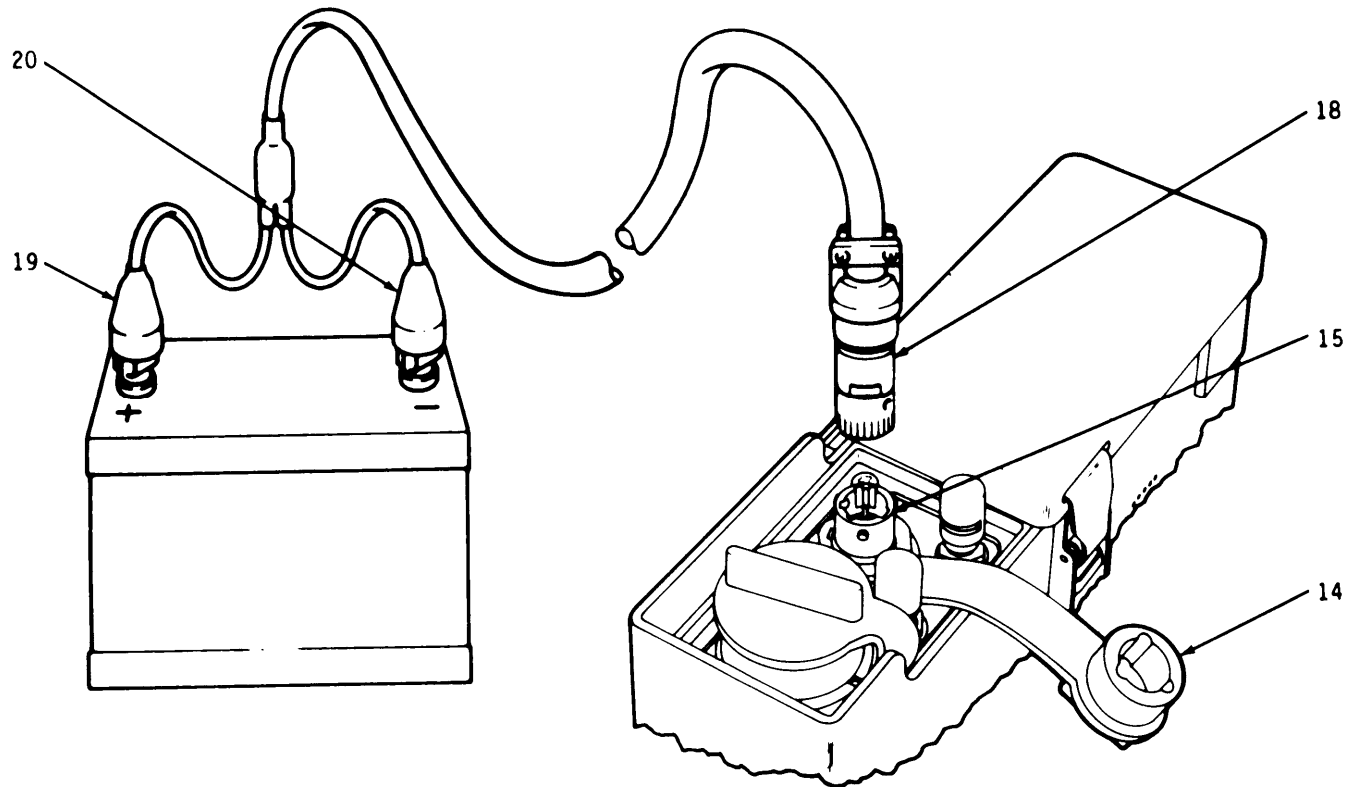
CAUTION

Do not connect MBC to external power, and do not start vehicle engine with MBC turned on. Make sure MBC ON/OFF switch is turned off. DISREGARDING THIS CAUTION COULD CAUSE EQUIPMENT DAMAGE .

- 13 Pull dustcover (14) from MBC power connector (15).

NOTE

Vehicle battery posts and battery cable clamps must be free of corrosion and dirt to ensure good electrical connection.

- 14 Connect vehicular battery cable plug labeled DMD (18) to MBC power connector (15).
- 15 Connect red-colored battery clamp (19), labeled POWER (20-32 VDC) VEHICULAR BATTERY, to positive (+) post of vehicle battery.
- 16 Connect black-colored battery clamp (20), labeled NEGATIVE VEHICULAR BATTERY, to negative (-) post of vehicle battery.

ASSEMBLY AND PREPARATION FOR USE (CONT)

COMMUNICATIONS INTERFACE CONNECTIONS

NOTE

The MBC may be interfaced by either of three methods, WD-1 field wire, primary radio interface cable, or AN/GRC-106 interface cable.

If using WD-1 field wire, perform steps 17 and 18.

If using primary radio interface cable, perform steps 19 through 21.

If using AN/GRC-106 interface cable, perform steps 22 through 24.

NOTE

Make sure MBC ON/OFF switch is turned off. MBC field wire binding posts are inoperative if either primary radio interface cable or AN/GRC-106 interface cable is connected to MBC.

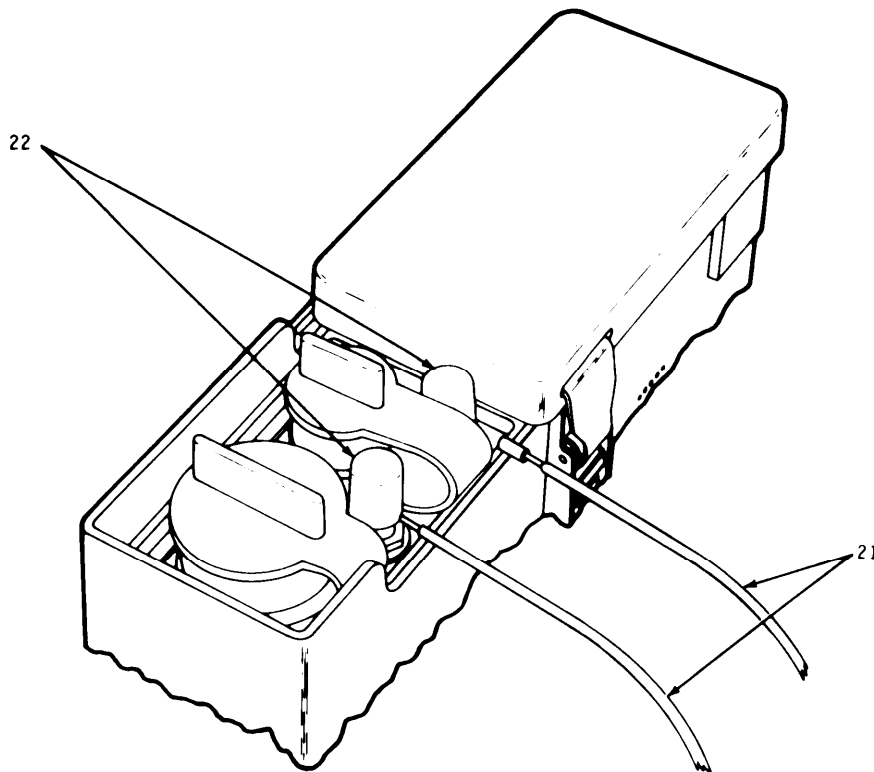

17 Strip one-half inch of insulation from ends of field wire (21).

18 Press cap on each binding post (22) and insert one wire in each binding post.

ASSEMBLY AND PREPARATION FOR USE (CONT)

NOTE

Make sure MBC ON/OFF switch is turned off.

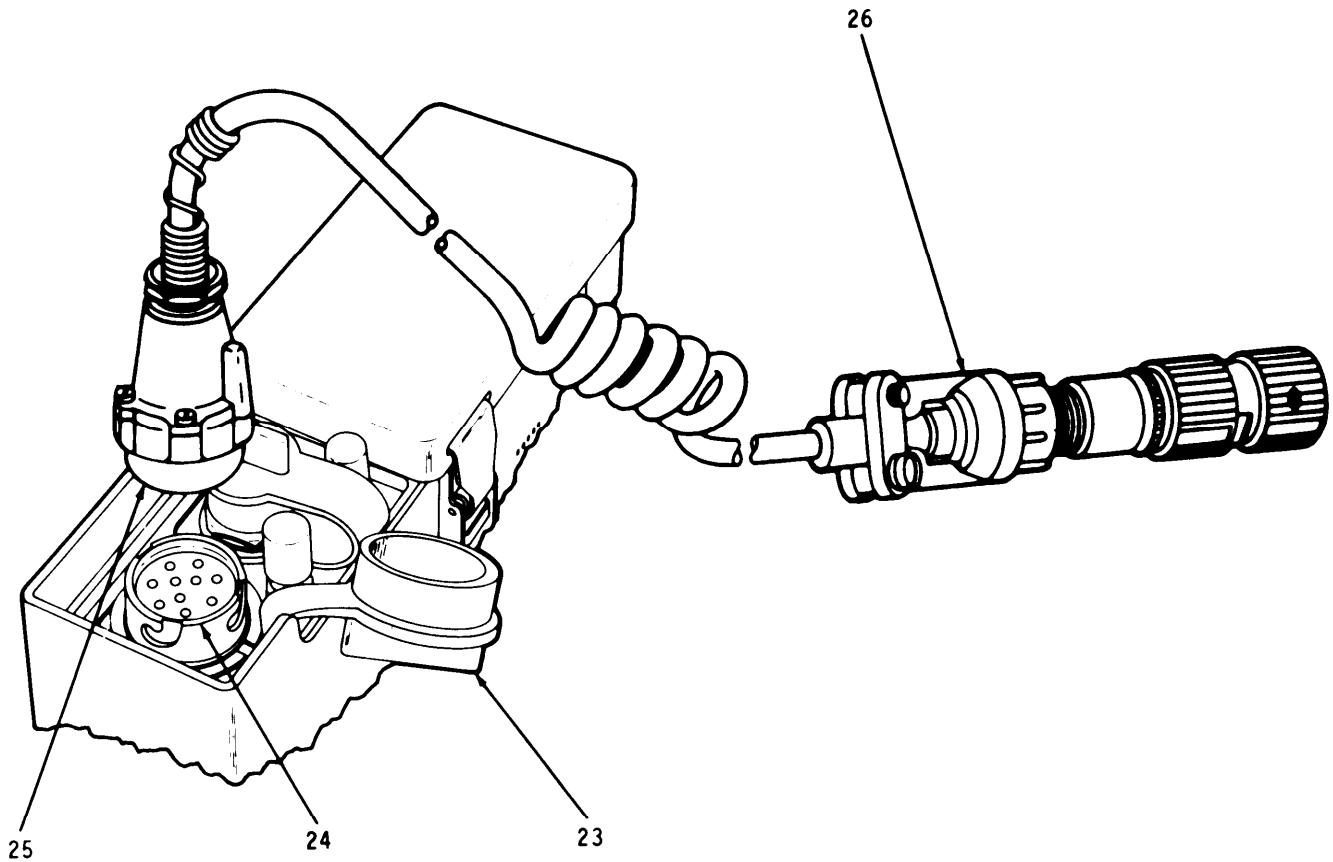

19 To connect MBC to FM radios and associated equipment, pull dustcover (23) from MBC radio connector (24).

20 Connect primary radio interface cable plug labeled DMD (25) to MBC radio connector (24).

21 Connect cable plug labeled RADIO (26) to radio set VRC-12, PRC-77, GRC-160, or associated equipment.

ASSEMBLY AND PREPARATION FOR USE (CONT)

CAUTION

Make sure MBC ON/OFF switch is turned off. Both ends of AN/GRC-106 interface cable have similar connectors. The end marked DMD must be connected to MBC for proper operation. DISREGARDING THIS CAUTION COULD CAUSE EQUIPMENT DAMAGE.

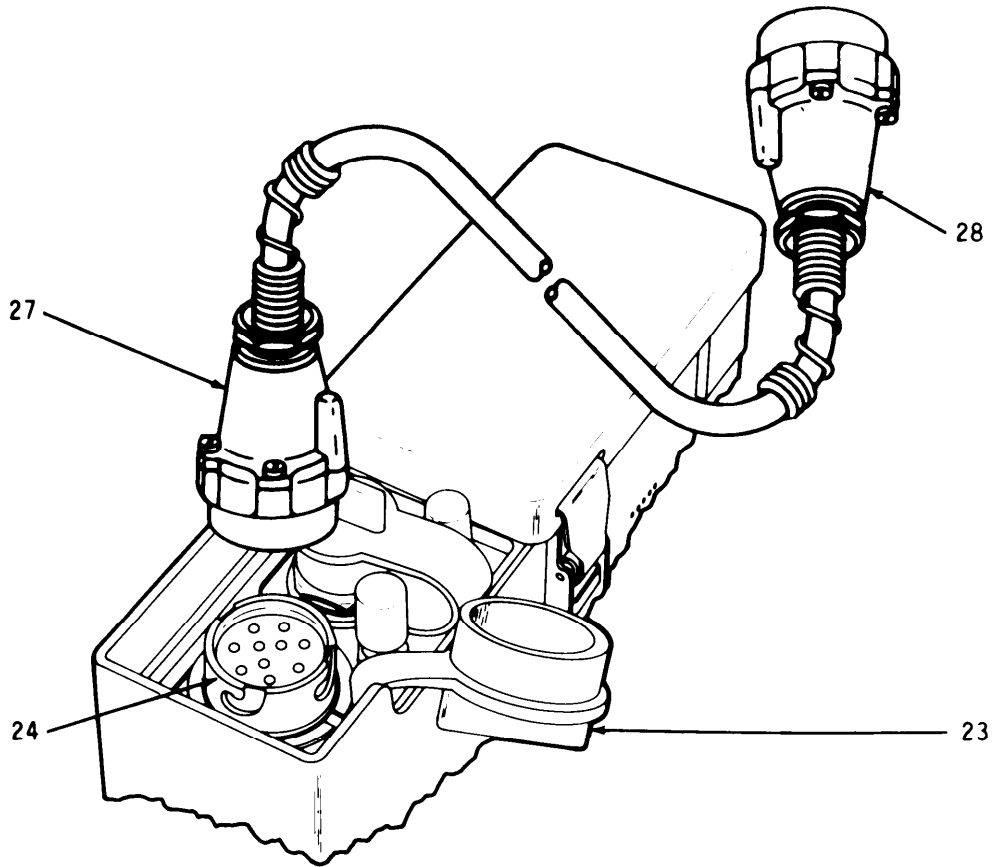

- 22 To connect MBC to AM radios and associated equipment, pull dustcover (23) from MBC radio connector (24).
- 23 Connect AN/GRC-106 interface cable plug labeled DMD (27) to MBC radio connector (24).
- 24 Connect cable plug labeled RADIO (28) to radio set GRC-106, or associated equipment.

INITIAL CHECKS

Perform "Before" PMCS entries including MBC Self-Test before operating MBC. You will be ready for operations after making the initial checks listed below.

- Initial Adjustments - No initial adjustments are necessary.
- Equipment - Check with your supervisor on the operating condition for your mission. Then inspect your equipment. Check the Components of End Item and Basic Issue Items Lists, Appendix C, to be sure you have everything needed to operate the MBC. Also look for damaged items. Report missing or damaged items to your supervisor.
- Power - Check with your supervisor on the type of power (internal battery or external power) you will be using on your mission. When using the internal battery, make sure you have a fully charged battery. When using external power, make sure the connections are tight both at MBC and power source.
- Communication Interfaces - Check with your supervisor on the type of communication interface you will be using on your mission. Make sure the connections are clean and tight both at MBC and at radio set.
- Transmission - Check with your supervisor on the type of transmission (single or double block) and rate of transmission (600 or 1200) you will be using on your mission.
- Origin and Destination - Check with your supervisor to make sure you have the valid codes for your mission.

OPERATING CONDITIONS

- When input power to MBC (internal battery or external power) is weak, BATT LOW indicator will flash or MBC will shut off.
- Display will automatically turn off after a preselected period once the last keyboard entry is made.

SELF-TEST

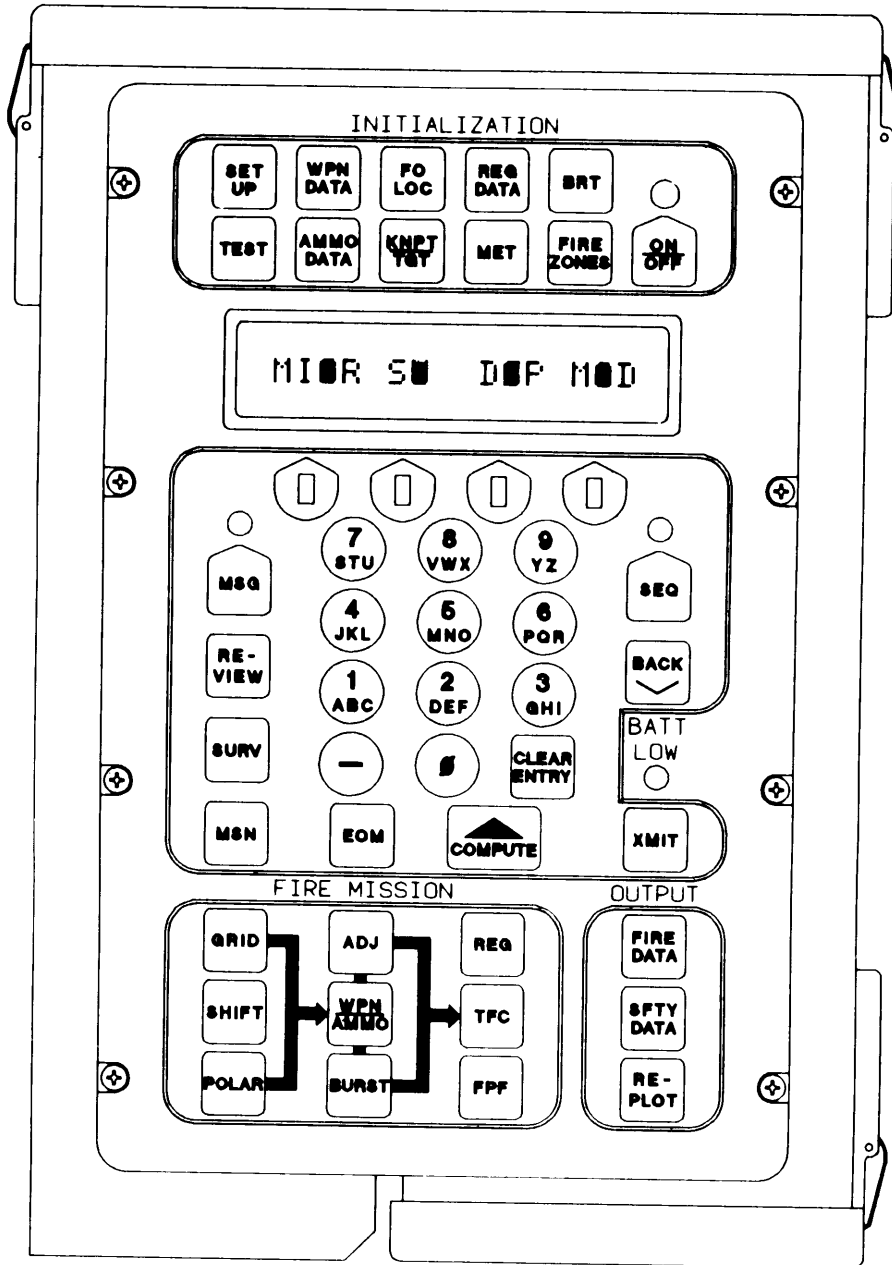

Self-Test provides testing of the microprocessor (MICR), all switches and keys (SW), the display and indicators (DSP), and the modem (MOD). These four tests may be performed in any sequence, but are presented here in the following order - MICR, SW, DSP, and MOD.

SELF-TEST (CONT)

DISPLAY

- 1 Press ON/OFF switch.
Display momentarily shows POWERUP TEST while performing internal checks.



POWERUP TEST

then shows:



READY

After pressing ON/OFF switch, if any display other than POWERUP TEST or READY appears take corrective measure.

CORRECTIVE MEASURE:
Return to next higher maintenance level.

NOTE

If BATT LOW indicator flashes or display does not appear, take corrective measure.

CORRECTIVE MEASURE:
Replace battery.

WARNING

When disposing of used battery do not incinerate, charge, or mutilate. An explosion or venting of toxic fumes may result. Dispose of used battery in accordance with standard procedures.

- 2 Press TEST switch.
After pressing TEST switch, if the software revision number is not displayed take corrective measure.

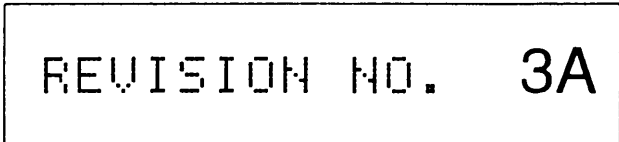

REVISION NO. 3A

CORRECTIVE MEASURE:
Return to next higher maintenance level.



SELF-TEST (CONT)

MICROPROCESSOR TEST

This self-contained test is manually started by selecting MICR on the display.

DISPLAY

3 Press SEQ switch.

MICR SW DEF MOD

4 Using multiple choice entry, select MICR.

TESTING MICR

After testing the microprocessor (approximately 38 seconds), if any display other than MICR:PASS appears, take corrective measure.

MICR:PASS

CORRECTIVE MEASURE:
Return to next higher maintenance level.

SWITCH TEST

The display directs the action for the switch test. Every switch is tested while pressed, starting with SET UP. As the switch is pressed, the name of the next switch to be tested will appear on the display.

5 Press REVIEW Switch.

MICR SW DEF MOD

SELF-TEST (CONT)

DISPLAY

- 6 Using multiple choice entry, select SW.

SET UP

When a switch fails or is pressed out of sequence the display shows:

ERROR

The word ERROR is displayed momentarily and the display returns to the name of the switch to be pressed. If you press the specified switch and ERROR reappears in the display, the switch is inoperative. Failure of the MBC to respond to a normal key press indicates a malfunctioning keyboard assembly.

CORRECTIVE MEASURE:
Return to next higher maintenance level.

- 7 Press SET UP switch.

WPN DATA

- 8 Press WPN DATA switch.

FO LOC

- 9 Press FO LOC switch.

REG DATA

SELF-TEST (CONT)

DISPLAY

10 Press REG DATA switch.

BRT

11 Press BRT switch.

AMMO DATA

12 Press AMMO DATA switch.

KNPT/TGT

13 Press KNPT/TGT switch.

MET

14 Press MET switch.

FIRE ZONES

15 Press FIRE ZONES switch.

DISPLAY SWITCH 1

display switch >1<

SELF-TEST (CONT)

DISPLAY

16 Press display switch 1.

DISPLA SWITCH 2

display switch >2<

17 Press display switch 2.

DISPLAY SWITCH 3

display switch >3<

18 Press display switch 3.

DISPLAY SWITCH 4

display switch >4<

19 Press display switch 4.

MSG

20 Press MSG switch.

REVIEW

21 Press REVIEW switch.

SURVEY

SELF-TEST (CONT)

DISPLAY

22 Press SURV switch.

MISSION

23 Press MSN switch.

EOM

24 Press EOM switch.

COMPUTE

25 Press COMPUTE switch.

XMIT

26 Press XMIT switch.

BACK

27 Press BACK switch.

SEQ

SELF-TEST (CONT)

DISPLAY

28 Press SEQ switch.

7/STU

29 Press 7/STU key.

8/VWX

30 Press 8/VWX key.

9/YZ

31 Press 9/YZ key.

4/JKL

32 Press 4/JKL key.

5/MNO

33 Press 5/MNO key.

6/PQR

SELF-TEST (CONT)

DISPLAY

34 Press 6/PQR key.

1/ABC

35 Press 1/ABC key.

2/DEF

36 Press 2/DEF key.

3/GHI

37 Press 3/GHI key.

-

38 Press - key.

0

39 Press 0 key.

CLEAR ENTRY

SELF-TEST (CONT)

DISPLAY

40 Press CLEAR ENTRY switch.

GRID

41 Press GRID switch.

ADJ

42 Press ADJ switch.

REG

43 Press REG switch.

FIRE DATA

44 Press FIRE DATA switch.

SHIFT

45 Press SHIFT switch.

WPN/AMMO

SELF-TEST (CONT)

DISPLAY

46 Press WPN/AMMO switch.

TFC

47 Press TFC switch.

SAFETY DATA

48 Press SFTY DATA switch.

POLAR

49 Press POLAR switch.

BURST

50 Press BURST switch.

FPF

51 Press FPF switch.

REPLOT

SELF-TEST (CONT)

DISPLAY

52 Press REPLOTT switch. The display momentarily shows:

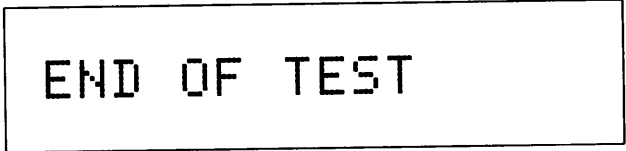

then shows:

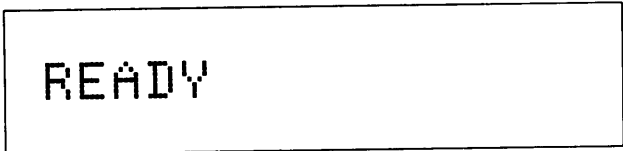

DISPLAY TEST

During first part of display test all dot segments are lighted in the sixteen character display. Check for unlighted dots. In second part of test, character generation and indicators are tested. Even though one or more dot segments may be out, MBC may be used if characters are readable. When characters are not legible or any indicator is not flashing, take corrective measure.

DISPLAY

53 Press REVIEW switch.

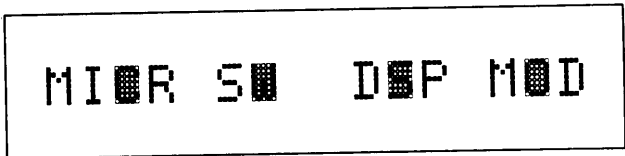

54 Using multiple choice entry, select DSP. Check for unlighted dot segments in each character space.

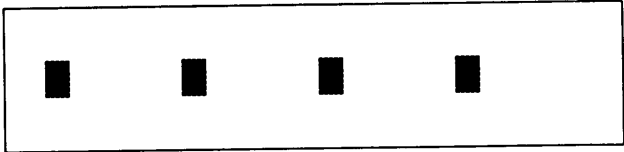

SELF-TEST (CONT)

DISPLAY

55 Press SEQ switch.
Check (for unlighted dot segments in each character space.

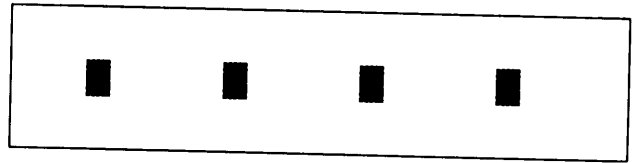

56 Press SEQ switch.
Check for unlighted dot segments in each character space.

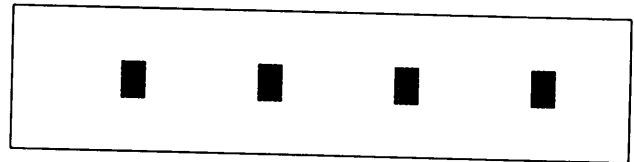

57 Press SEQ switch.
Check for unlighted dot segments in each character space.

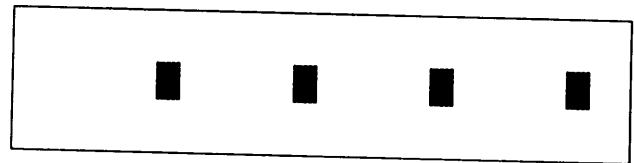

CORRECTIVE MEASURE:
Return to next higher maintenance level.

58 Press SEQ switch.
Check for presence of all characters.

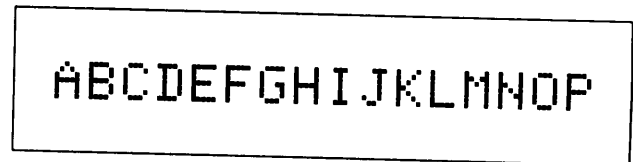

59 Press SEQ switch.
Check for presence of all characters.

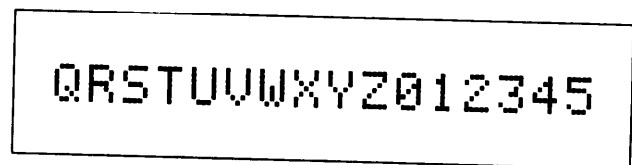

SELF-TEST (CONT)

DISPLAY

60 Press SEQ switch.

Check for presence of all characters.

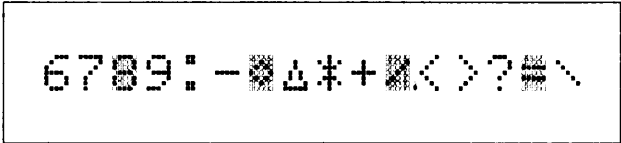

Check for flashing characters 8, ◇, /, and =. Characters alternate from character to 5 by 7 lighted dot segments.

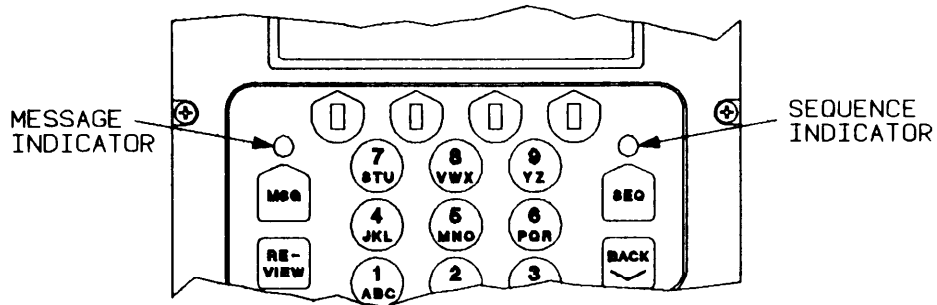

61 Check for flashing message and sequence indicators. Message indicator will flash five times per second.

CORRECTIVE MEASURE:
Return to next higher maintenance level.

SELF-TEST (CONT)

MODEM TEST

DISPLAY

62 Press REVIEW switch.

MIOR SW DSP MOD

Using multiple choice entry, select MOD.

TESTING MODEM

63 After testing modem (approximately 20 seconds), the display shows:

MODEM:PASS

(OR)

If modem fails, message transmission and reception will be inoperable, although MBC will still accept manual input data and compute fire missions.

MODEM:FAIL

TRANSMIT TEST MESSAGE

The transmit test message allows the communications network to be checked without having active fire mission data in the MBC. A freetext message is sent to a DMD or another MBC.

 SELF-TEST (CONT)

 MBC PREPARATION

- SET UP Switch - Use default communication values.
- Set OWN ID to A. For MBC to MBC test, set receiving MBC OWN ID to B.
 - Use radio or field wire hookup.

 DMD PREPARATION

Use default communication values.
 Set ORIGIN to B.
 Set DEST to A.

For DMD operation refer to TM 11-7440-281-12&P.

DISPLAY

- 64 Press REVIEW switch.

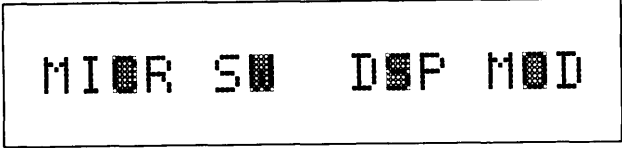

MIOR S0 D0P M0D

- 65 Press SEQ switch.

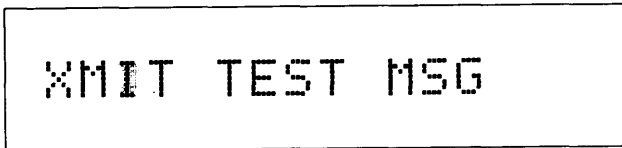

XMIT TEST MSG

- 66 Using multiple choice entry, select XMIT. Using alpha entry, enter routing information. Enter B.



ROUTE:B *XMIT

SELF-TEST (CONT)

DISPLAY

67 Using multiple choice entry, select * to transmit test message. The display momentarily shows:

TRANSMITTING

then shows: (Automatic response from DMD or MBC when message is received)

ACK

OR

(Displayed when ACK not received from DMD or MBC). After three tries, troubleshoot communications network.

NO RSP RETRY 1

68 Press ON/OFF switch
(End of Self-Test procedure.)

INITIALIZATION

GENERAL

Before computing a fire mission certain initialization switches must be used to load the MBC with basic data. The following paragraphs provide an overview of the initialization switches and explain how they are affected by the different modes of operation.

Modes of Operation.

Manual Mode.

When the MBC is not connected to an external communication device (manual mode of operation), all data is manually entered.

Digital Mode.

When the MBC is connected to an external device (DMD - supported) data is digitally entered into appropriate switch memory. Data entered digitally may be reviewed and/or supplemented.

Minimum Initialization.

TEST and BRT. Are used first to check overall MBC operation and to set display brightness.

SET UP and WPN DATA. Are two mandatory switches that must be initialized before a standard GRID fire mission can be started (minimum initialization). They are always manually initialized. Their data never changes as a result of other switch actions, although the operator may review and update these switches as needed. When AMMO DATA switch default values are suitable, the AMMO DATA switch is not required.

Expanded Initialization.

The switches -- MET, FIRE ZONES, FO LOC, KNPT/TGT, and REG DATA -- are initialized as data becomes available (expanded initialization).

MET. Is always manually initialized for entry of nonstandard MET data when available. When the MET switch is not used, the MBC uses standard (STD) MET data.

INITIALIZATION (CONT)

FIRE ZONES. Is always manually initialized and manually updated when used.

FO LOC. Is manually initialized and updated when in manual mode. When MBC is DMD-supported, inputs are automatically entered when a valid observer location message is received.

KNPT/TGT. May be initialized and updated at any time regardless of mode of operation. The KNPT/TGT switch may be updated automatically by the use of EOM, REPLOTT, and SURV switches, or by receiving KNPT/TGT related digital messages.

REG DATA. Is initialized manually to maintain a registration file when enough data is known from conducting a fire mission. Normally registration data is generated automatically by using the REG switch during fire mission processing. However, data manually entered with the REG DATA switch will be automatically updated when the REG switch is used to compute registrations.

Tactical Scene.

Overall MBC initialization is directly related to the tactical scene. Always initialize SET UP, WPN DATA, and AMMO DATA switches. Initialize other switches as needed. Press the GRID switch. Use the SEQ switch to sequence past the first four menus and enter target Easting and Northing coordinates. Sequence past the altitude entry to the READY display. Press the WPN AMMO switch. Press the SEQ switch until the READY display appears. Press COMPUTE switch. Press SEQ switch to view fire commands.

DATA

The following information will be used as SAMPLE DATA for initialization switch entries. By using this data, the MBC will be pre-initialized for performing the sample fire missions. If different data is used, the fire commands for the sample fire mission problems will not reflect what is shown in this manual. Using the step-by-step instructions, initialize the MBC with the following data.

INITIALIZATION (CONT)

SET UP switch (Operational and communications data)

Timeout: 60 seconds
Target prefix: AH
Target. numbering block: 0001 - 9999
Message alarm : OFF
Easting (area of operation): 096000 (Full Easting - 596000)
Northing (area of operation): 029000 (Full Northing - 4929000)
Grid Declination: 580 mils East
Latitude: 44 degrees North
Digital communication: Listen only to OFF
Bit rate: 1200 bits per second
Keystone: 1.4
Block mode: Single
Computer owner's identification address: A

WPN/DATA switch (Weapon data)

Unit: A
Caliber: 107mm
Tube default elevation: 800
Carrier mounted: NO
Base piece: A2
Base piece location E: 04000
 N: 47000
Altitude: 0750 meters
Azimuth of fire: 0800
Deferred deflection: 2800

Weapon No. 1: Direction - 1600
 Distance - 035

Weapon No. 3: Direction - 4800
 Distance - 028

Weapon No. 4: Direction - 4800
 Distance - 040

AMMO DATA switch (Ammunition data for 107mm only)

Powder temperature: +70 degrees F
HE: M329A1 - 4 Squares (4 Squares = 26.73 lb.)
WP: M328A1 - Weight standard
ILL: M335A2 - Noncorrectable
CS: M630-Weight standafd

INITIALIZATION (CONT)

MET switch (Meteorological data)

Meteorological: NEW
 Quadrant: 1
 Latitude: 443
 Longitude: 341
 Date: Day - 10
 Time - 095
 Duration - N/A
 Station height: 049
 Atmospheric pressure: 987

MET data for line-by-line entry

<u>Line NO</u>	<u>Wind Direction (Mils X 10)</u>	<u>Wind Speed (Knots)</u>	<u>Temperature (0.1 Kelvin)</u>	<u>Pressure (Millibars)</u>
00	310	04	2977	0972
01	290	13	2956	0961
02	306	14	2904	0933
03	357	14	2834	0890
04	396	07	2809	0837
05	502	08	2804	0787
06	450	15	2781	0742
07	475	13	2744	0696
08	520	13	2705	0653

FIRE ZONE switch (Fire zone and fire line data)

<u>Zone Designation</u>	<u>Type of Zone</u>	<u>Number of Points</u>	<u>Easting</u>	<u>Northing</u>
Fire line	Line	MIN (1)	04750	51450
		MIN (2)	06950	50200
		MAX (3)	05500	52360
1	No Fire Zone	03	11530	49760
			13050	47230
			10000	47200
2	No Fire Zone	07	08000	52410
			07910	54040
			09580	54020
			10410	55550
			11890	55540
			11890	54060
			10020	52360

INITIALIZATION (CONT)

FO LOC switch (Forward observer location data)

<u>Network ID</u>	<u>FO Number</u>	<u>Easting</u>	<u>Northing</u>	<u>Altitude</u>
A	00	06510	46460	0630
B	01	02370	47460	1010
B	02	04410	48210	0580
B	03	05110	50540	0320

KNPT/TGT switch (Known point target point data)

<u>KNPT Number</u>	<u>Target Number</u>	<u>Easting</u>	<u>Northing</u>	<u>Altitude</u>
01	--	06640	51350	0290
02	--	10110	50360	0080
03	--	01900	54760	1530
04	AH 0003	01880	49790	0550
05	AH 0015	10270	48600	0020

REG DATA switch (Registration point data)

<u>REG NO</u>	<u>Easting</u>	<u>Northing</u>	<u>Altitude</u>	<u>WPN</u>	<u>ELEV</u>	<u>MET</u>	<u>RCF</u>	<u>DEFK</u>
01	07570	49300	0120	A2	800	CURR	+100	L020
02	01880	49790	0550	A2	800	CURR	+200	L040
03	06520	50120	0140	A2	800	CURR	-150	R010

INITIALIZATION PROCEDURE

Initialization switches are discussed in the following order: TEST, BRT, SET UP, WPN DATA, WPN AMMO, MET, FIRE ZONES, FO LOC, KNPT/TGT, and REG DATA. Entering the SAMPLE DATA given will provide computed output for a standard grid fire mission.

INITIALIZATION (CONT)

TEST

Use TEST switch to manually start MBC Self-Test as described in detail under SELF-TEST on page 2-36. Perform SELF-TEST as your situation permits or when advised by your supervisor.

DISPLAY

- 1 Press ON/OFF switch.
The display momentarily shows:

POWERUP TEST

then shows:

READY

BRT

Use BRT switch to select level of display character brightness (LOW, MED, HI, and MAX). Use the LOW level to turn on the keyboard background lighting. Character brightness is always set HI when the MBC is turned on, or when the BRT switch is pressed.

- 2 Check character brightness.
If acceptable go to step 5.
- 3 Press BRT switch. Using multiple choice entry, set brightness to suit your lighting conditions.

BRT: H■

- 4 Press SEQ switch.

READY

INITIALIZATION (CONT)

SET UP

Use SET UP switch to control communication functions and enter-operational data. For manual operation sequence by communication related displays; alarm, listen only, bit rate, keystone, and blk sng.

DISPLAY

- 5 Press SET UP switch. Using multiple choice entry, change timeout to 60.



TIME OUT: 60

Timeout is used to set number of seconds (15, 30, 45, or 60) the display stays on between delayed switch actions. Default provides minimal battery drain.

- 6 Press SEQ switch. Using correction entry, clear target prefix field. Using alpha entry, enter target prefix. Select from range AA through ZZ. Enter AH.

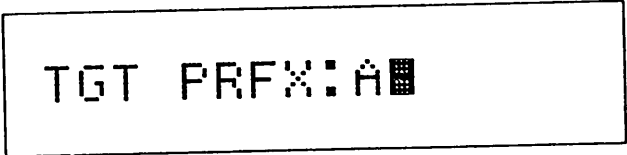

TGT PRFX: A

- 7 Press SEQ switch. Using correction entry, clear target number fields. Using numeric entry, enter target numbering block. Select from range 0 through 9999. Enter 0001, 9999.

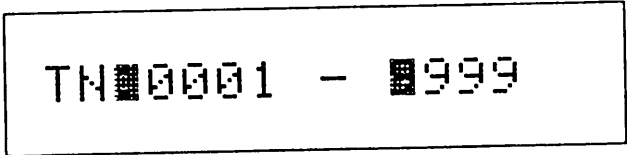

TN 0001 - 9999

- 8 Press SEQ switch. Use the default shown.

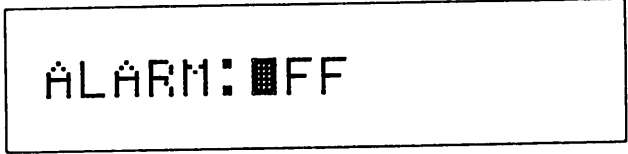

ALARM: OFF

Use message alarm as needed for DMD - supported missions.

NOTE

Enable alarm will also sound for violations of fire zones, fire lines, forward observer, and friendly weapon danger.

INITIALIZATION (CONT)

DISPLAY

- 9 Press SEQ switch. Using correction entry, clear Easting field. Using numeric entry, enter minimum Easting coordinate. Enter 096.

MIN E:096000

Enter minimum Easting and Northing coordinates at lower left corner of your area of operations.

- 10 Press SEQ switch. Using correction entry, clear Northing field. Using numeric entry, enter minimum Northing coordinate. Enter 029.

MIN N:029000

NOTE

MBC usest his grid declination value to convert the wind directions in non-standard MET only. The MBC operator must ensure that the directional values from an FO are compensated by the grid declination value used in the area.

- 11 Press SEQ switch. Using correction entry, clear grid declination field. Using direction and numeric entry, enter grid declination E or W and amount in tens of mils. Enter E58.

GD E58

- 12 Press SEQ switch. Using direction and numeric entry, enter latitude (+ North), (- South) of Equator and amount in degrees. Enter +44.

LAT: +44

- 13 Press SEQ switch. Use the default shown.

LISTEN ONLY: OFF

The listen only modem function default (OFF) allows MBC message transmission and reception. When listen only is (ON) MBC will receive messages, but will not send an ACK or transmit a message.

INITIALIZATION (CONT)

DISPLAY

- 14 Press SEQ switch. Use the default shown.
- Message transmission rate (BIT RATE) is used for DMD - supported missions. All devices on the communicating net must be set at the same rate, 600 bps or 1200 bps.
- 15 Press SEQ switch. Using multiple choice entry, change KEYTONE to 1.4. Transmitter warmup delay time (KEYTONE) is used for DMD - supported missions. A message transmitted by the MBC is delayed for a period of time in seconds selected in KEYTONE. This delay allows the radio transmitter to "warm up" and prevents the message from being lost. Usually set at 2.1 for radios and 0.7 for wire. Choices are 0.2, 0.7, 1.4, 2.1, 2.8, 3.5, 4.2, and 4.8.
- 16 Press SEQ switch. Use the default shown.
- Transmit block mode single (SNG) or double (DBL) is used for DMD - supported missions. All devices on the communicating net must be on the same mode.
- 17 Press SEQ switch. Using correction entry, clear ID field. Using alpha entry, enter owner identification, A through Z or 0 through 9. Enter A.



BIT RATE: 1000



KEYTONE: 1.4



BLK: SNG

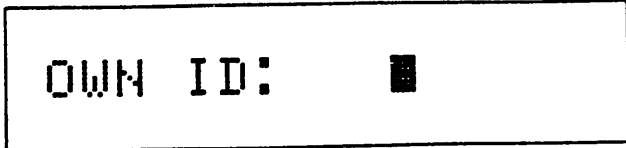

OWN ID: A

INITIALIZATION (CONT)

DISPLAY

18 Press SEQ switch.

READY

WPN DATA

Use WPN DATA switch to enter weapon data for section(s) A, 8, or C. Assign one, two, or all three sections. A total of 18 weapons may be assigned (six per section) A1 through A6, B1 through B6, C1 through C6. The first weapon entered in a section becomes the base piece (A1, B1, C1). The base piece weapon (Easting and Northing coordinates) is the reference point for identifying and adding additional weapons to a section.

NOTE

The MBC builds a model of a MAP based on the MIN. EAST and the MIN. NORTH grids in the set up data. The MBC will not warn the operator if his mortar position grid or target grid is outside this model. The operator should ensure that his MIN. EAST and MIN. NORTH are far enough away from the mortar position to ensure 6400 MIL operation at MAX range.

19 Press WPN DATA switch.

■ ■ ■

20 Using multiple choice entry, select section A, B, C, or D. Select A.

■ 0 ■ 1 1 ■ 7 1 ■ 0 

21 Using multiple choice entry, select caliber type 60,81, 107, or 120. Select 107.

107 DEF EL ■ 800

INITIALIZATION (CONT)

DISPLAY

- 22 Using multiple choice entry, select tube elevation 800, 900, or 1065. Use default shown (800). Press SEQ switch. Carrier applies to 81 mm, 107mm, and 120mm mortars, but is not used for this example.
- 23 Press SEQ switch. (Ground muzzle velocity correction in use.)
- 24 Press SEQ switch. Using numeric entry, enter base piece number. Enter 2.
- 25 Press SEQ switch. Using numeric entry, enter base piece Easting and Northing map coordinates. Enter Easting 04000. Enter Northing 47000.
- 26 Press SEQ switch. Using numeric entry, enter altitude of base piece. Enter 0750 meters.
- 27 Press SEQ switch. Using numeric entry, enter base piece azimuth of fire and deferred deflection in mils. Enter azimuth 0800. Enter deflection 2800.
- 28 Press SEQ switch. When no more weapons are to be entered, use multiple choice entry to select END. Go to step 29.

CARRIER: N■

GROUND MV ENTRD

107 BP: A■

E: ■4000 N■47000

AL■:0750

AZ■0800 DE■:2800

CO■T E■D

INITIALIZATION (CONT)

DISPLAY

To continue entering weapons, use multiple choice entry to select CONT. Select CONT and go to step 30.

- 29 Observe READY. Go to step 33, AMMO DATA switch.



- 30 Using numeric entry, enter next weapon number in the section. Enter 1.

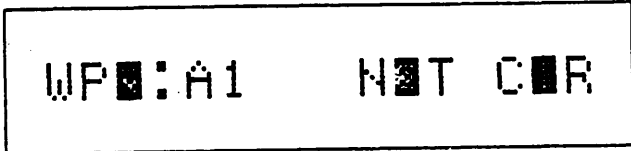

- 31 Press SEQ switch. Using numeric entry, enter weapon direction in mils and distance in meters from base piece. Enter 1600 and 035.

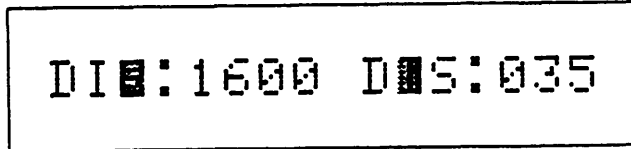

- 32 Repeat step 28 and enter weapons 3 and 4 with the following sample data:

Weapon No. 3: Direction - 4800 mils
Distance - 028 meters

Weapon No. 4: Direction - 4800 mils
Distance - 040 meters

AMMO DATA

Use AMMO DATA switch to select shell types for each ammunition type for caliber in use. Powder temperature default is 70 degrees and correctable. Three 107 mm ammo types are weight-square correctable. They are M329A1, M328A1 and CS M830. When corrections are entered, the word NO on the right side of the display is changed to CR. Weight changes are entered in pounds or squares. When pounds or squares are entered, a conversion is made to show both unit entries. When AMMO DATA switch default values are suitable, the AMMO DATA switch is not required.

INITIALIZATION (CONT)

Selectable shell types for each ammunition type per caliber are:

<u>CALIBER</u>	<u>AMMUNITION TYPE</u>	<u>SELECTABLE SHELL TYPE</u>
60mm	HE- high explosive	M720*, M49A4, M888
	WP - white phosphorus	M302A1*, M722, M302A2
	ILL - illumination	M83A3*, M721
81mm	HE	M374*, M374A2, M374A3, M821, M821A1, M889, M889A1
	WP	M375*, M375A2, M375A3
	ILL	M301A3*, M853A1
	TRN - training rounds	M1* , M68, M879, M880
	RP - red phosphorus	M819*
107mm	HE	M329A1*, M329A2
	WP	M328A1 only
	ILL	M335A2 only
	CS - Tactical	M630 only
120mm	HE	M933, M934, M57
	WP	M929, M68
	ILL	M930, M91

* Default

Menus for 60mm, 81mm, 107mm, and 120mm are very similar in format The following displays show only 107mm ammunition shell type assignments, with a weight correction in squares applied to HE M329A1.

INITIALIZATION (CONT)

DISPLAY

33 Press AMMO DATA switch.

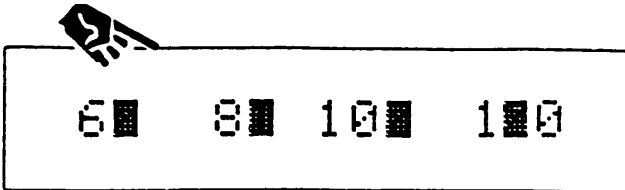

33.1 Press SEQ switch.

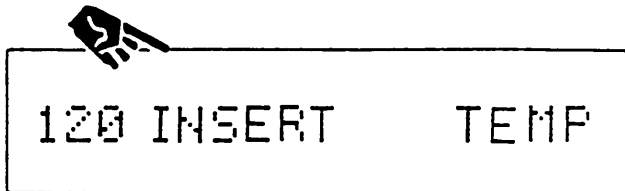

33.2 Press SEQ switch.
Menu will show "READY."

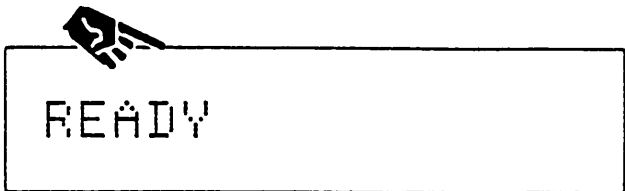

33.3 Press AMMO DATA switch.

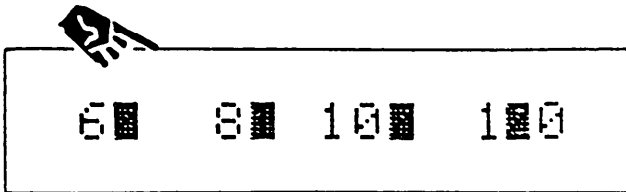

34 Using multiple choice entry,
select caliber. Select 107.

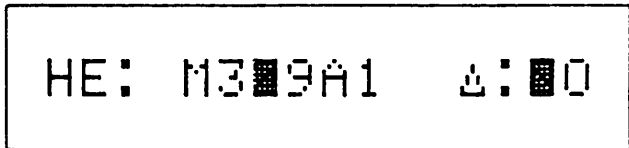

35 Using multiple choice entry,
select NO to apply corrections.
Select NO.

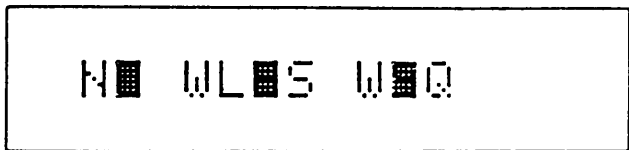

36 Using multiple choice entry,
select WSQ to apply weight cor-
rection in squares. Select WSQ.
Using numeric entry, enter 4.

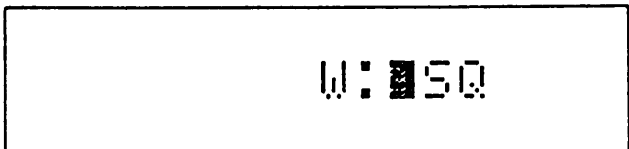

INITIALIZATION (CONT)

DISPLAY

- 37 Press SEQ switch. (Ammo and shell type are shown with correction applied.)



```
HE: M3 9A1  Δ: R
```

- 38 Press SEQ switch. WP shell type M328A1 weight-correctable)

```
WP: M328A1  Δ: 0
```

- 39 Press SEQ switch.

```
ILL: M335A2
```

- 40 Press SEQ switch.

```
CS: M630  Δ: 0
```

- 41 Press SEQ switch.

```
READY
```

MET

Use MET switch to enter non-standard (computer-generated MET data). When new MET message data is entered it becomes the current MET used when the UPDATE * option is selected. When UPDTE * is not selected the data is retained in file as NEW MET, but not used for computation. When the MET switch is not used the MBC uses standard (STD) MET. Selecting CURRENT in the first MET display allows review only. Selecting NEW allows entry, review, or changes to NEW MET. Both NEW and CURRENT MET can be deleted by selecting CLR in the second display. Use new MET data when available to provide more accurate ballistic computations.

INITIALIZATION (CONT)

DISPLAY

42 Press MET switch.

MET: NEW CURRENT

43 Using multiple choice entry, select NEW. Using numeric entry enter octant. Enter 1.

METCM,N 0:1 CUR

44 Press SEQ switch. Using numeric entry, enter latitude and longitude. Enter 443 and 341.

LA443 LO341

45 Press SEQ switch. Using numeric entry, enter day of month and time of message (GMT). Enter 10 and 095.

D:10 T:095 G:0

46 Press SEQ switch. Using numeric entry, enter station altitude and atmospheric pressure. Enter 049 and 987.

SA0490 AT987

Begin entry of nine lines of MET data (lines 00 through 08).

47 Press SEQ switch. Using numeric entry, enter line 00 wind direction and speed. Enter 310 and 04.

00:3100 :004

INITIALIZATION (CONT)

DISPLAY

48 Press SEQ switch. Using numeric entry, enter line 00 temperature and air pressure. Enter 2977 and 0972.

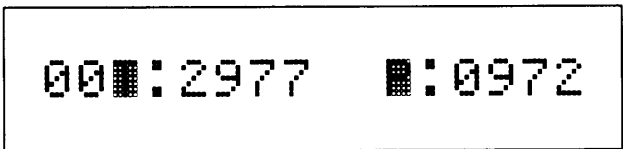

49 Press SEQ switch.
(Start of line 01.)

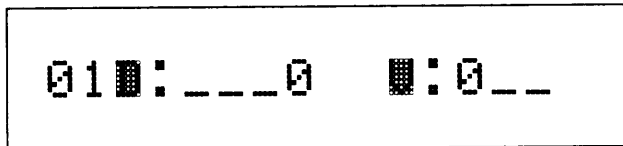

Repeat steps 47 through 49 to complete MET entry for lines 01 through 08. Use the following data starting with line no. 01.

<u>Line No.</u>	<u>Wind Direction (Mils X 10)</u>	<u>Wind Speed (Knots)</u>	<u>Temperature (0.1 Kelvin)</u>	<u>Pressure (Millibars)</u>
00	310	04	2977	0972
01	290	13	2956	0961
02	306	14	2904	0933
03	357	14	2834	0890
04	396	07	2809	0837
05	502	08	2804	0787
06	450	15	2781	0742
07	475	13	2744	0696
08	520	13	2705	0653

50 Press SEQ switch.

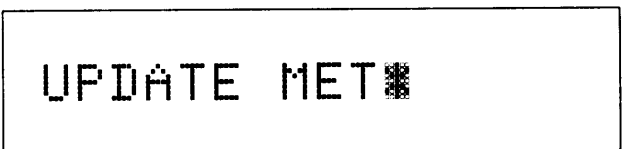

51 Using multiple choice entry, select * to update the current MET stored in the MBC.

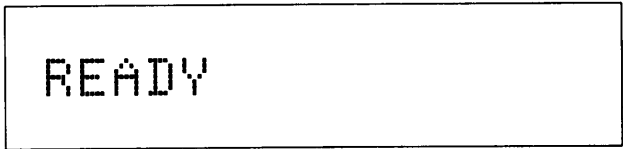

INITIALIZATION (CONT)

FIRE ZONES

Use FIRE ZONES switch to enter fire zones or enter a minimum and maximum fire line. Eighty points are available for setting up fire zones.

To enter a fire line use steps 52 through 58.
 To enter fire zones use steps 59 through 62.

NOTE

When a maximum and a minimum fire line are used they are set up in parallel as shown. When MBC determines that a burst location falls above or below the fire line area, a violation message is displayed. The fire line for computation extends beyond the line between the coordinates entered.

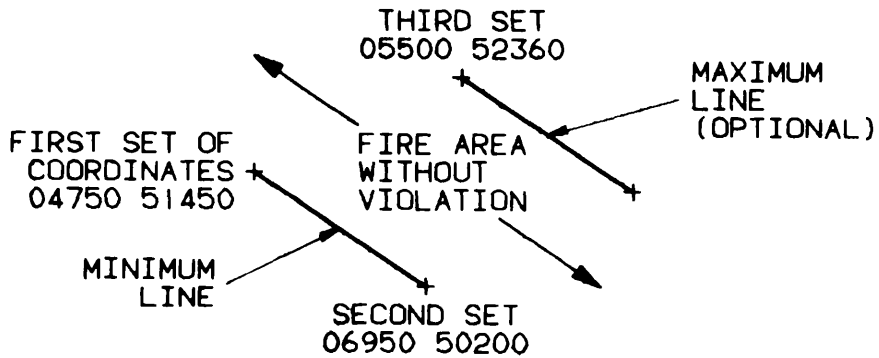

INITIALIZATION (CONT)

DISPLAY

52 Press FIRE ZONES switch.

L Z

53 Using multiple choice entry
select LN.

LN:MIN C R

54 Press SEQ switch. Using numeric
entry, enter first set of coordi-
nates. Enter 04750 and 51450.

E:04750 N#51450

55 Press SEQ switch. Using numeric
entry, enter second set of co-
ordinates. Enter 06950 and
50200.

E:06950 N#50200

56 Press SEQ switch.
The next display allows
coordinate entry for a
maximum fire line when
needed.

LN:MAX

57 Press SEQ switch. Using numeric
entry, enter third set of
coordinates. Enter 05500 and
52360.

E:05500 N#52360

INITIALIZATION (CONT)

DISPLAY

58 Press SEQ switch.

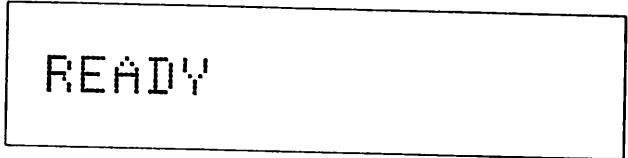

FIRE ZONES

To set up a fire zone (no fire area), a minimum of three points must be entered. Eighty points are available, but no more than 10 zones maybe entered. MBC will not compute gun orders for burst locations within afire zone. The sequence in which the operator enters these coordinates is very critical. The shape of the No-Fire zone can vary significantly based on the order; the operator must "connect the dots" when drawing out the No-Fire zone, and then enter these coordinates in the same order. For example, if a box can be drawn by points A-B-C-D, and the operator enters A-C-B-D instead, a bow tie shaped zone will result instead of a box.

Examples of fire zones are as follows:

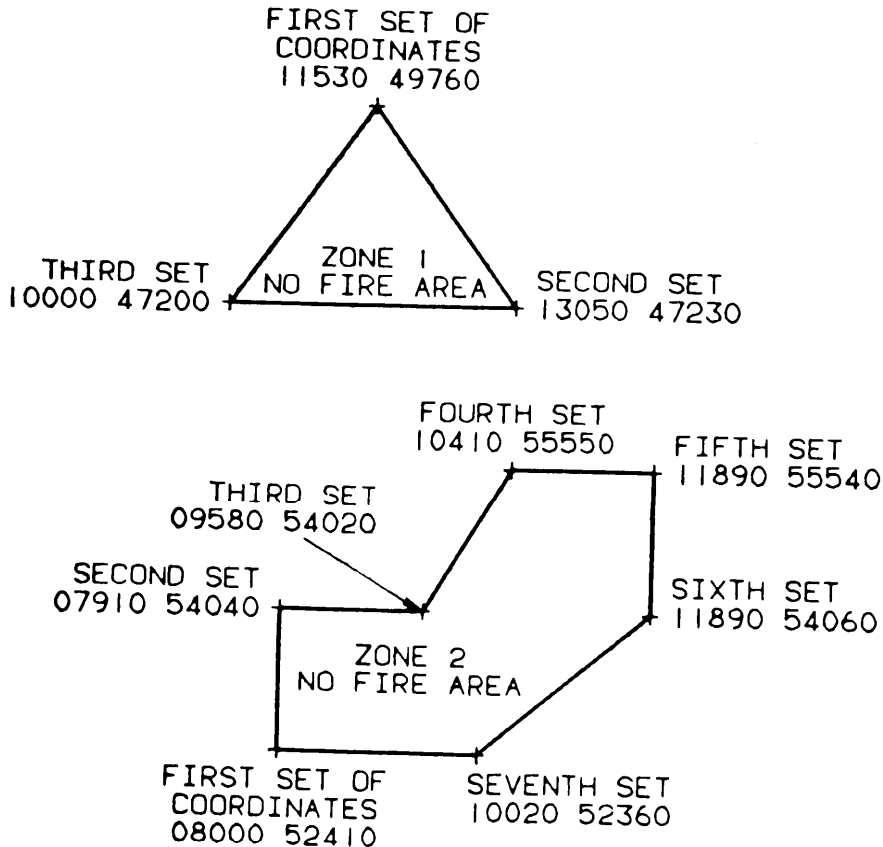

INITIALIZATION (CONT)

DISPLAY

59 Press FIRE ZONES switch.



60 Using multiple choice entry, select ZN. Using numeric entry enter fire zone number, 0 through 9. Enter 1.

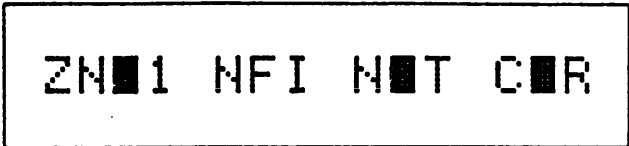

61 Press SEQ switch. Using numeric entry, enter number of points used to set up the fire zone. Enter 03.



62 Press SEQ switch. Using numeric entry, enter first set of Easting and Northing zone coordinates. Enter 11530 and 49760.

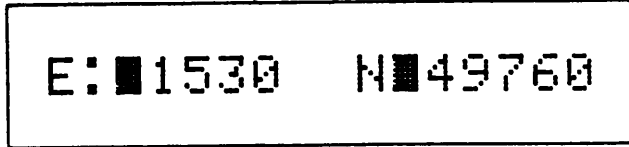

Repeat step 62 until zone 01 coordinates are entered. Use the following data.

Easting

Northing

13050
10000

47230
47200

Press SEQ switch. Display will show:

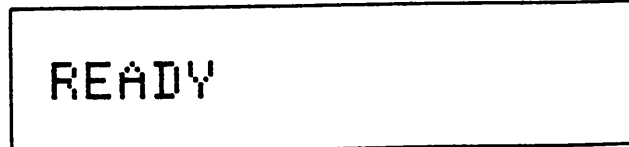

INITIALIZATION (CONT)

Repeat steps 59 through 62 and enter the following data for fire zone 02.

Zone Designation	Number of Points	Easting	Northing
2	07	08000	52410
		07910	54040
		09580	54020
		10410	55550
		11890	55540
		11890	54060
		10020	52360

FO LOC

Use FO LOC switch to enter forward observer (FO) identification, location altitude. As many as 12 FO's with data may be entered.

FO DISPLAY VARIATIONS

Display number 1

63 Press FO LOC switch. Display number 1 allows FO entry using the NETWORK ID field with observer number 00. Legal entries are 0 through 9 and A through Z. Display number 1 is the default for normal FO entry when a DMD is used.

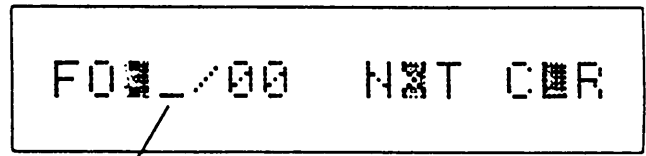

Field 1

Display number 2

64 Using multiple choice entry, select FO:. Display number 2 allows two-digit FO entry disregarding the NETWORK ID field. Legal entries are 00 through 99. Use two-digit FO entry when a FIST DMO is used.

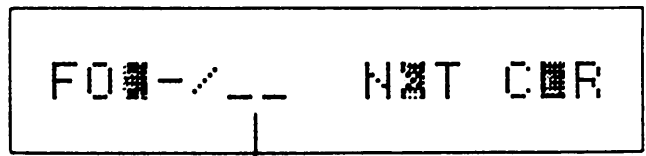

Field 2

Using multiple choice entry, select FO: to move back and forth from display number 2 to display number 1 as needed.

INITIALIZATION (CONT)

Display number 3

65 With display number 2 shown, press CLEAR ENTRY switch. Display number 3 allows entry of NETWORK ID and FO number entry when FIST DMO operation becomes intermittent. Manually entering the known NETWORK 10 and FO observer number will allow communication with the DMD.

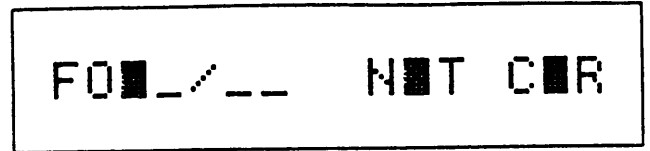

Using multiple choice entry, select FO: to return display number 2.

When reviewing a previously entered FO in the FO LOC menu during a fire mission, or displaying a digital message, a third field (routing NET ID) is displayed for FO identification. This field shows the operator the last TACFIRE (FIST identification number) that sent a particular message. For example:

(Sample display only.)

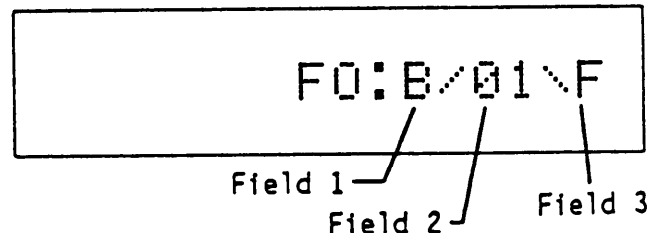

- Field 1 - NETWORK ID, DMD identification number B.
- Field 2 - Message is from FO number 01.
- Field 3 - Routing NET IO; FIST Identification number F, origin of last message received from FO number 01.

INITIALIZATION (CONT)

DISPLAY

66 Press FO LOC switch. Using alpha entry, enter FO number. Enter A.

FO A/00 NOT CLR

67 Press SEQ switch. Using numeric entry, enter FO Easting and Northing coordinates. Enter 06510 and 46460.

E: 06510 N 46460

68 Press SEQ switch. Using numeric entry, enter FO altitude in meters (-399 through 9999) when known. Enter 0630.

AL: 0630

69 Press SEQ switch.

Repeat steps 66 through 69 and enter FO no's 01, 02, and 03. Use the following data starting with FO number 01.

READY

<u>Network ID</u>	<u>FO Number</u>	<u>Easting</u>	<u>Northing</u>	<u>Altitude</u>
A	00	06510	46460	0630
B	01	02370	47460	1010
B	02	04410	48210	0580
B	03	05110	50540	0320

NOTE

To enter FO 01 (with NET ID B), enter B first, then press CLEAR ENTRY switch and enter 1. To enter 02 and 03, press display switch 1, then enter observer number.

INITIALIZATION (CONT)

KNPT/TGT

Use KNPT/TGT switch to enter an assigned number to known points or targets and related data. KNPT/TGT data includes coordinates and altitude. When a target is entered, it may also be assigned a known point. The KNPT/TGT file is shared between KNPT's and TGT's allowing 50 points.

To enter KNPT data use steps 70 through 74.
To enter TGT data use steps 75 through 80.

DISPLAY

70 Press KNPT/TGT switch.



KNPT TGT

71 Using multiple choice entry, select KNPT. Using numeric entry, enter KNPT number 00 through 99. Enter 01.

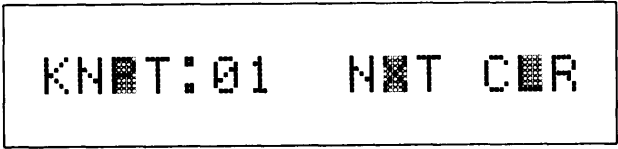

KNPT:01 NPT CLR

72 Press SEQ switch. Using numeric entry, enter KNPT Easting and Northing coordinates. Enter 06640 and 51350.



E:06640 N51350

73 Press SEQ switch. Using numeric entry, enter KNPT altitude in meters when known. Enter 0290.



ALT:0290

74 Press EQ switch.



READY

INITIALIZATION (CONT)

Repeat steps 70 and 74 and enter KNPT's 02 and 03 using the following data.

KNPT/TGT switch (Known/Target point data)

<u>KNPT Number</u>	<u>Target Number</u>	<u>Easting</u>	<u>Northing</u>	<u>Altitude</u>
01	--	06640	51350	0290
02	--	10110	50360	0080
03	--	01900	54760	1530
04	AH 0003	01880	49790	0550
05	AH 0015	10270	48600	0020

DISPLAY

75 Press KNPT/TGT switch.

KNPT TGT

76 Using multiple choice entry, select TGT. Using numeric entry, enter TN number. Enter 0003.

TN AH0003 NXT CL

77 Press SEQ switch. Using numeric entry, enter optional KNPT for target 03. Enter 04.

KNPT:04 NXT

78 press SEQ switch. Using numeric entry, enter target coordinates, Enter 01880 and 49790.

E:01880 N049790

INITIALIZATION (CONT)

DISPLAY

- 79 Press SEQ switch. Using numeric entry, enter TGT altitude in meters. Enter 0550.

AL■:0550

- 80 Press SEQ switch.

Repeat steps 75 through 80 and enter target 15 using the KNPT/TGT data provided.

READY

REG DATA

Use REG DATA switch to enter new registration data, to review existing data, or to update the stored information in the current files. Sixteen registration points (RP) are allowed (00 through 15). The REG files contain RP location, the unit that fired the registration, the fired charge (60mm, 81mm, or 120mm) or elevation (107mm), type of MET used when the firing occurred, and range and correction deflection factors based on the SHOT and DID HIT data. ■

Registration files are normally set up automatically by using the REG switch. REG files can be entered manually if all the necessary information is available. This includes range and deflection corrections. Unlike automatically set up files, manually entered files cannot be updated (UPDATE *) after entry of new MET data.

To manually enter or review a new REG file use step 81 and steps 84 through 91. All data is computer-entered for review.

To update the REG file use steps 81 through 83.

- 81 Press REG DATA switch. Using numeric entry, enter RP number 00 through 15. Enter 01.

RP■01 HIT C■R

INITIALIZATION (CONT)

DISPLAY

82 Press SEQ switch. Select * to apply new MET data to existing RP. This display only appears while reviewing an existing automatically entered RP.

UPDATE REG■

83 Press SEQ switch.

READY

84 Press SEQ switch. Using numeric entry, enter RP Easting and Northing coordinates. Enter 07570 and 49300.

E:■7570 N■49300

85 Press SEQ switch. Using numeric entry, enter altitude in meters (-399 through 9999) when known. Enter 0120.

AL■:0120

86 Press SEQ switch. Using alpha and numeric entry, enter weapon unit and number for new RP. Enter A2.

107 W■N:A2

87 Press SEQ switch. Using multiple choice entry, select elevation for newly fired 107mm RP. Use default shown.

ELEV: ■00

INITIALIZATION (CONT)

DISPLAY

88 Press SEQ switch. Using multiple choice entry, select type of MET used (standard or current) when new RP was fired. Select CURR.

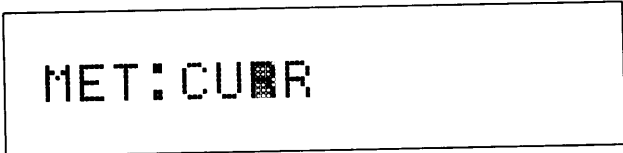

89 Press SEQ switch. Using direction and numeric entry, enter range correction factor for manual entry of new RP. Enter +100 meters.

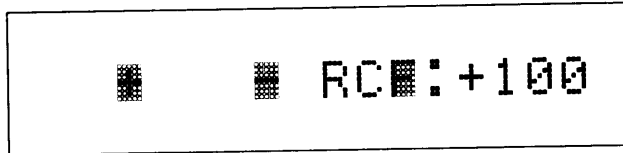

90 Press SEQ switch. Using direction and numeric entry, enter deflection correction factor for manual entry of new RP. Enter L020 mils.

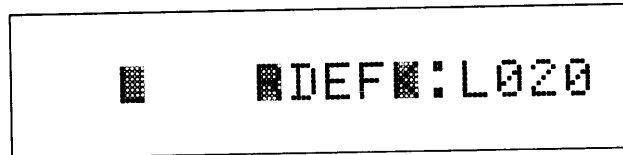

91 Press SEQ switch.

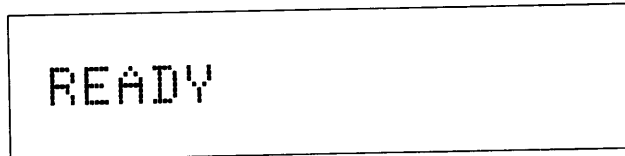

Repeat step 81, and steps 84 through 91 and enter registration points 02, and 03 using the following data.

<u>REG NO</u>	<u>Easting</u>	<u>Northing</u>	<u>Altitude</u>	<u>WPN</u>	<u>ELEV</u>	<u>MET</u>	<u>RCF</u>	<u>DEFK</u>
01	07570	49300	0120	A2	800	CURR	+100	L020
02	01880	49790	0550	A2	800	CURR	+200	L040
03	06520	50120	0140	A2	800	CURR	-150	R010

INITIALIZATION (CONT)

DATA REVIEW

Before starting fire missions all initialization data should be reviewed to ensure proper entry. To review data press specified switch, make required selections, then press SEQ switch. Make corrections only as needed. The following WPN DATA switch review shows how to:

Use SEQ switch to review data.

Use NXT to access the next set of data.

Use numeric entry to manually enter a selection for review.

Use CLR to clear an entire data file or clear a single data set.

These rules also apply to other initialization switches.

NOTE

Read the following example, but do not change the data entries. If data is cleared now, it must be reentered to run the sample fire mission data in MANUAL INPUT MISSIONS.

DISPLAY

1 Press WPN DATA switch. Section A is assigned, base piece is weapon number 2. B and C do not have a trailing digit (not assigned).

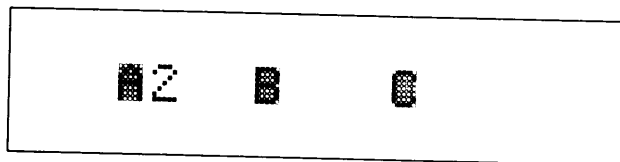

2 Using multiple choice entry, select AZ. (Caliber 107mm, default tube elevation 800)

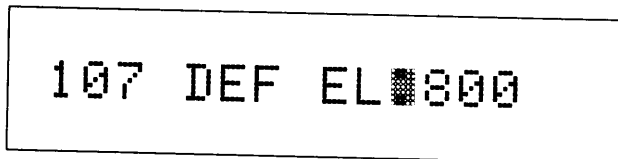

INITIALIZATION (CONT)

DISPLAY

3 Press SEQ switch. (Caliber 107mm is assigned to section A, base piece is A2.)

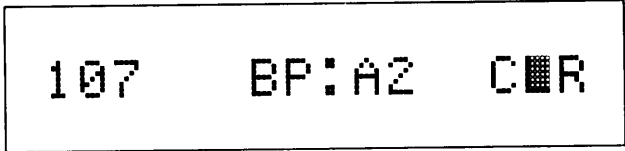

NOTE

When CLR appears, prepare to clear the entire file. If CLR were selected, a second display would appear as a caution, to confirm clearing.

Second display would show:
(Confirm clearing battery A)

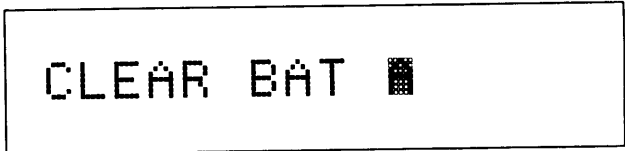

Selecting A would clear battery A as follows:

Display would then show:

(Battery A cleared - trailing digit 2 removed)

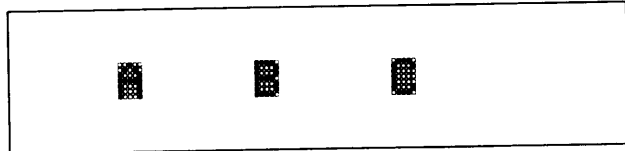

4 If CLR is not selected, press SEQ switch to review data, (Base piece Easting and Northing coordinates)

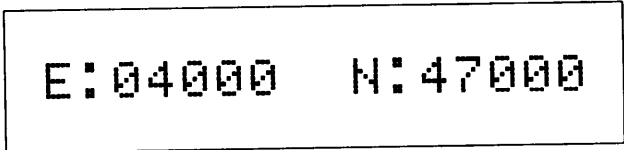

5 Press SEQ switch. (Base piece altitude)

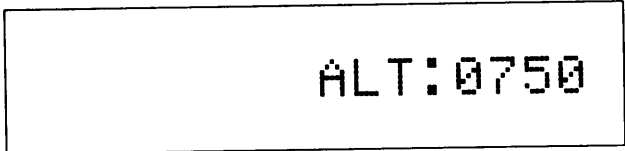

INITIALIZATION (CONT)

DISPLAY

6 Press SEQ switch. (Base piece azimuth and deflection in mils)

AZ:0800 DEF:2800

7 Press SEQ switch. Use CONT to check for additional weapons or END to end weapon data review.

CONT END

8 Using multiple choice entry, select CONT for this example. Using numeric entry, enter number of weapon to be viewed, if known. or using multiple choice entry, select (NXT) until desired weapon number is displayed. Additional weapons 1, 3, and 4 are in the weapon data file from initialization. For this example review number 4.

WP#:A_ NXT CLR

9 Using multiple choice entry, select NXT three times. (Section A, weapon number 4)

WP#:A4 NXT CLR

NOTE

When NXT CLR appears, selecting CLR clears only a single set of data.

INITIALIZATION (CONT)

DISPLAY

10 Press SEQ switch to view data.
(Weapon direction and distance
from base piece)

DIR: 4800 DIS: 040

11 Press SEQ switch.
Using multiple choice
entry, select CONT.

CONT END

WPN: A_ NRT CLR

NOTE

Review weapons 1 and 3. When review is
finished, select END. Observe (READY).

MANUAL INPUT MISSIONS

FIRE MISSION PROCESSING AND CONTROL (MANUAL ENTRY)

The following table lists the sequence of actions required to conduct a manual fire mission. A sample Grid Fire Mission is provided using the actions in the listing. Before starting the mission, base piece weapon (A2) location is confirmed by using the SURV switch (resection method). Next, a safety fan is entered into the MBC before conducting the fire mission. Last, a FPF line is entered.

MANUAL INPUT MISSIONS (CONT)

Fire Mission Processing and Control

ACTION NUMBER	ACTION	SWITCH	PAGE NUMBER
1	START FIRE MISSION - When target location is identified by: Grid coordinates - Shift from existing known/target point - Direction and distance from an existing FO location	GRID SHIFT POLAR	2-96 --- ---
2	Select: 1) Fire units 2) Shell/fuze 3) Charge or elevation	WPN AMMO	2-97
3	Select: 1) Method of control 2) Type of sheaf 3) If REG/MET data is not to be used	TFC	2-112
4	Compute and review fire commands	COMPUTE	2-99
-	Send fire commands to guns (voice)	--	
5	Format message to observer (MTO)	XMIT	2-100
-	Read message to observer (voice)	--	

FIRE - FIRST ROUND GOES OUT

PERFORM ADJUSTMENT(S) TO BURST LOCATION

ACTION NUMBER 6 REPEATED UPON REQUEST

6	Enter observer corrections: Using non-laser equipment -	ADJ	2-102
	Using laser equipment -	BURST	---

MANUAL INPUT MISSIONS (CONT)

Fire Mission Processing and Control (CONT)

FINAL ADJUSTMENT - FIRE FOR EFFECT (FFE)

ACTION NUMBER	ACTION	SWITCH	PAGE NUMBER
7	Compute and review fire commands	COMPUTE	2-99
	Send fire commands to guns (voice)	--	
8	Enter observer corrections: Using non-laser equipment -	ADJ	2-102
	Using laser equipment -	BURST	---
9	When shell/fuze combination is to be changed -	WPN AMMO	2-97
10	To change method of control	TFC	2-112
11	Compute and review fire commands	COMPUTE	2-99
	Send fire commands to guns (voice)	--	
END OF MISSION			
12	End of mission or end of mission record as target	EOM	2-120

MANUAL INPUT MISSIONS (CONT)

SAMPLE SURVEY PROBLEM

TASK

Determine base piece location using the resection method. The base location has been entered from initialization. Use the resection method to confirm your location. Since the base piece exists, you cannot restore it, but you can compare the computed coordinates against the initialization entry.

GIVEN

You are trying to locate your base piece location but are unsure of your location on the map. You can identify two known points. One is a church located at Grid 00750 46600 with a vertical angle of -20 and a direction of 4680. The other known point is a road intersection at direction 5760 mils.

SOLUTION

The known points given must be entered in the KNPT/TGT switch before solving the problem. The road intersection is KNPT 04 and has been entered during initialization. The church location must be assigned a KNPT and entered. KNPT's 01, 02, 03, 04, 05 are in use. Using KNPT/TGT switch, enter KNPT 06 for the church. Enter coordinates 00750, 46600. Leave the altitude entry blank (unknown). Use the SURV switch resection method as follows:

SURV

Use SURV switch to select and solve any one of three types of survey problems; resection (RES), intersection (INT), or traverse (TRV). Use RES to determine the coordinates and altitude of an unknown point, in this example, base piece location. RES requires two azimuth entries from the unknown point to the known points and the vertical angle from the unknown point to the first known point entered in the MBC. Refer to the following diagram.

MANUAL INPUT MISSIONS (CONT)

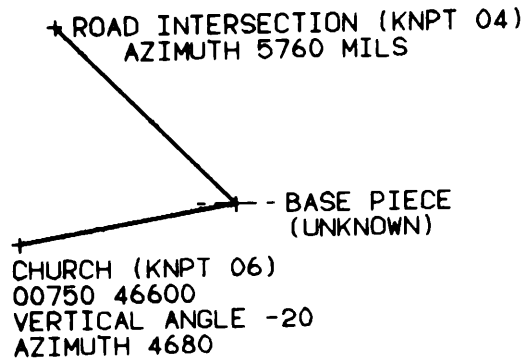

DISPLAY

1 Press SURV switch.

RES IN TRU

2 Using multiple choice entry, select resection (RES). Using numeric entry, enter first KNPT and azimuth from unknown point to first KNPT. Enter 06, 4680.

KNPT:06 DIR:4680

3 Press SEQ switch. Using direction and numeric entry, enter vertical angle, up or down, and angle in mils. Enter D0020.

■ ■VAN00020

4 press SEQ switch. Using numeric entry, enter second KNPT and azimuth from unknown point to second KNPT. Enter 04, 5760.

KNPT:04 DIR:5760

MANUAL INPUT MISSIONS (CONT)

DISPLAY

5 Press SEQ switch.

PUSH COMPUTE

6 Press COMPUTE switch. (Computed coordinates of unknown point)
Base piece coordinates entered in initialization are 04000, 47000.

E:03924 N:46975

7 Press SEQ switch. (Computed altitude of unknown point)

ALT:----

NOTE

Altitude above is not shown because altitude was unknown for KNPT 06.

8 Press SEQ switch. By using multiple choice entry, type of storage can be selected. Sequence indicator is lit for additional selection (TGT).

STR: B F KN T

In this example no storage entries will be made. This concludes the sample survey problem.

9 Press SEQ switch two times.

READY

MANUAL INPUT MISSIONS (CONT)

SAMPLE SAFETY DATA ENTRY

TASK

Enter a safety fan/diagram for your base piece.

GIVEN

You have been tasked to enter a safety fan for your base piece located at 04000, 47000. Your left limit azimuth is 5600 mils. The right limit azimuth is 1600 mils. Maximum range is 5800 meters. Minimum range is 1000 meters.

SOLUTION

Use the SFTY DATA switch to enter the safety fan.

SFTY DATA

Use SFTY DATA switch to review safety factors for an active fire mission, to enter complete boundaries for a safe fire area, and to enter minimum and maximum charge limits. When a fire mission is completed, end of mission (EOM), the safety factors are automatically cleared from the file. The MBC can store three safety diagrams (A, B, and C) with each diagram capable of having ten fans (0 to 9). An example of an irregular shape fan is shown on p 2-94.

A safety diagram is only applied to the gun(s) in a battery/section having the same letter designation as that of the safety diagram. Improperly matching safety diagram letter designations will result in a failure to detect and provide warning of violations to the intended safety diagram. For example: if the burst point of a gun in section A is outside safety diagram B, the MBC would not recognize it as a safety violation.

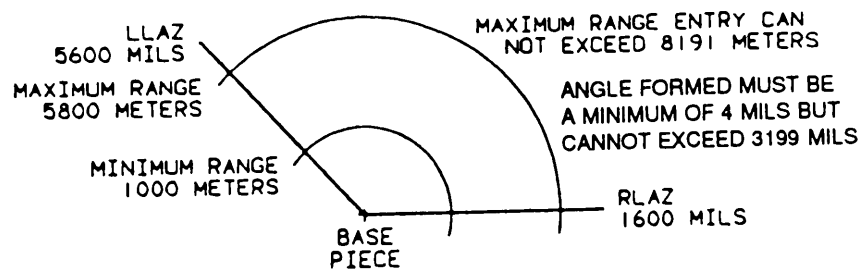

NOTE

The MBC displays SAFETY VIOLATION when burst points fall outside the fan limits. The resulting fire commands are not displayed. Safety fans are normally for peacetime (training).

MANUAL INPUT MISSIONS (CONT)

DISPLAY

1 Press SFTY DATA switch. Display momentarily shows:

NO OUTPUT DATA

2 Press SEQ switch. Enter safety diagram identification. (Will be entered by computer if fire mission is entered.) Enter A.

SAFETY DIAGRAM A

2.1 Press SEQ switch.

2.2 Press "0" for fan "0." Proceed to step 3 and continue as normal.

FAN NUMBER: 0

3 Press SEQ switch. Using numeric entry, enter left limit azimuth in mils. Enter 5600.

LLAZ: 5600

4 Press SEQ switch. Enter right limit azimuth. Enter 1600.

RLAZ: 1600

5 Press SEQ switch. Using numeric entry, enter maximum range in meters. Enter 5800.

MAX RN: 5800

MANUAL INPUT MISSIONS (CONT)

DISPLAY

6 Press SEQ switch. Enter minimum range. Enter 1000.

MIN RN: 1000

7 Press SEQ switch. Using numeric entry, enter minimum and maximum charge when needed. Charge limits are not used for this example.

MI: _ MAX: _ CHG

8 Press SEQ switch. Using multiple choice entry, select END. Selecting DIA starts entry for safety diagram B. Selecting FAN starts entry for next fan in current diagram.

NXT DIA FAN END



READY

MANUAL INPUT MISSIONS (CONT)

SAMPLE SAFETY DATA ENTRY FOR IRREGULAR FAN PATTERN

TASK

Enter safety fans/diagrams for your base piece.

GIVEN

You have been tasked to enter a safe fan for your base piece located at 04000,47000. Fan 0- Your left limit azimuth is 5600 mils. The right limit azimuth is 6200 mils. Maximum range is 5800 meters. Minimum range is 1000 meters. Fan 1 - Your left limit azimuth is 6200 mils. Your right limit azimuth is 6400 mils. Maximum range is 7000 meters. Minimum range is 1500 meters.

SOLUTION

Use the SFTY DATA switch to enter the safety fan.

SFTY DATA

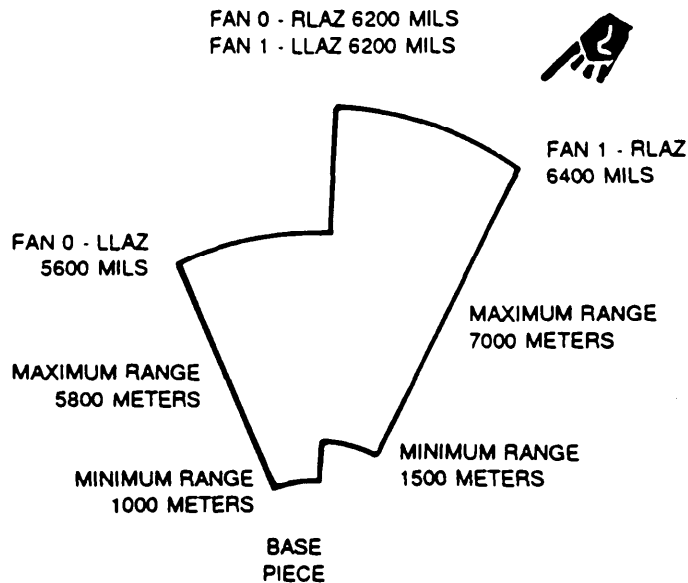

MANUAL INPUT MISSIONS (CONT)

DISPLAY

- 1 Press SFTY DATA switch.
Display momentarily shows:

NO OUTPUT DATA

- 2 Enter safety diagram identification - A, B, or C. (Will be entered by computer if fire mission is entered.) Enter B.

SAFETY DIAGRAM B

- 3 Press SEQ switch. Press "0" for fan "0."

FAN NUMBER: 0

- 4 Press SEQ switch. Using numeric entry, enter left limit azimuth in roils. Enter 5600.

LLAZ: 5600

- 5 Press SEQ switch. Enter right limit azimuth. Enter 6200.

RLAZ: 6200

- 6 Press SEQ switch. Using numeric entry, enter maximum range in meters. Enter 5800.

MAX RN: 5800

MANUAL INPUT MISSIONS (CONT)

DISPLAY

7 Press SEQ switch. Enter minimum range.
Enter 1000.

MIN RN: 1000

8 Press SEQ switch. Using numeric entry,
enter minimum and maximum charge
when needed. Charge limits are not used
for this example.

MI: _ MAX: _ CHG

9 Press SEQ switch.

NXT DIR FAN END

10 Select FAN. Computer will default to next
fan number.

FAN NUMBER: 0

NOTE
10 fans for A
10 fans for B
10 fans for C

11 Press SEQ switch. Using numeric entry,
enter left limit azimuth in roils. Enter
6200.

LLAZ: 6200

12 Press SEQ switch. Enter right limit
azimuth. Enter 6400.

RLAZ: 6400

MANUAL INPUT MISSIONS (CONT)

DISPLAY

13 Press SEQ switch. Using numeric entry, enter maximum range in meters. Enter 7000.

MAX RN:7000

14 Press SEQ switch. Enter minimum range. Enter 1500 mils.

MIN RN:1500

15 Press SEQ switch. Using numeric entry, enter minimum and maximum charge when needed. Charge limits are not used for this example.

MI: _ MAX _ CHG

16 Press SEQ switch. Using multiple choice entry, select END. Selecting DIA starts entry for safety diagram C. Selecting FAN starts entry for next fan in current diagram.

NXT DIA FAN END

READY

MANUAL INPUT MISSIONS (CONT)

SAMPLE GRID FIRE MISSION

TASK

Conduct a Standard Grid Fire Mission.

NOTE

The INITIALIZATION data input (steps 1 through 91) must have been previously entered into the M8C for the proper solution to be displayed.

GIVEN

FO 1 observed three armored personnel carriers in the vicinity of grid 03150, 51000 at altitude 720 meters. FO 1 direction to target is 0220. You have elected to fire the base piece in adjustment and the section in effect (parallel sheaf). You have also elected to fire shell HE and fuze quick at an elevation of 800 mils. Three volleys will be fired for effect.

FO 1 observes the initial round and requests an adjustment of Left 200, Add 300.

FO 1 observes the second round and requests an adjustment of Right 50, Add 100.

FO 1 observes the third round and requests an adjustment of Drop 50, fire for effect.

Your fire for effect lands in the area of the personnel carrier destroying one and disabling one. Fourteen enemy have been killed. FO 1 sends an end of mission, record as target.

MANUAL INPUT MISSIONS (CONT)

SOLUTION

The following table provides a switch sequence to solve the Sample Grid Fire Mission.

SEQUENCE NUMBER	SWITCH	EXPLANATION	PAGE NUMBER
1	GRID	FO number 1 reported map Grid coordinates.	2-96
2	WPN AMMO	MANDATORY	2-97
3	COMPUTE	Compute fire commands for first round to target.	2-99
4	XMIT	Format message to observer using MTO selection - read message to observer.	2-100
5	ADJ	Enter observer adjustments to first round. (first adjustment)	2-102
6	COMPUTE	Compute fire commands for second round.	2-105
7	ADJ	Enter observer adjustments to second round. (second adjustment)	2-106
8	COMPUTE	Compute fire commands for third round.	2-108
9	ADJ	Enter observer adjustments to third round. (third adjustment)	2-110
10	TFC	Forward observer 1 requested fire for effect after the third round. Change method of control to FFE.	2-112
11	COMPUTE	Compute fire commands for each weapon (fire for effect).	2-114
12	EOM	Forward observer requested end of mission record as target.	2-120

MANUAL INPUT MISSIONS (CONT)

GRID

Use GRID switch to start a fire mission when target location is identified by grid coordinates using 5 place Easting and 5 place Northing. The following displays show data for the Sample Grid Fire Mission.

NOTE

To review mission data, press MSN switch.
Use SEQ switch to sequence through mission data. Do not press GRID, SHIFT, or POLAR switches to review data.

DISPLAY

- 1 Press GRID switch.

FR GRID

- 2 Press SEQ switch. Using alpha entry, enter B. press CLEAR ENTRY switch. Using numeric entry, enter FO number 1. Enter 1.

FO: B/01 \-

- 3 Press SEQ switch. (Mission and target number entered by computer)

MSN: 1 TN: AH0001

- 4 Press SEQ switch. Using multiple choice entry, select gun-target line (GT) or using numeric entry, enter FO direction to target when known. Enter 0220.

G DI: 0220

- 5 Press SEQ switch. Using numeric entry, enter target coordinates. Enter Easting 03150, Northing 51000.

E: 03150 N: 51000

MANUAL INPUT MISSIONS (CONT)

DISPLAY

- 6 Press SEQ switch. Using numeric entry, enter target altitude in meters when known. Enter 0720 meters.

AL■:0720

NOTE

When target altitude is unknown MBC uses fire unit altitude.

- 7 Press SEQ switch.

READY

WPN AMMO

Use WPN AMMO switch to enter or change weapons and/or ammunition to be used for an active fire mission. Select section and piece to fire. Select ammunition type, fuze type, and elevation. Following displays show data for the Sample Grid Fire Mission.

- 8 Press WPN AMMO switch.

WPN/AMMO

- 9 Press SEQ switch. (FO number entered by computer)

FO: E/01 \-

MANUAL INPUT MISSIONS (CONT)

DISPLAY

10 Press SEQ switch. (Mission and target number entered by computer)

MSN: 1 TN: AH0001

11 Press SEQ switch. Using alpha and numeric entry, enter section and weapon number to fire. Enter A2.

107 W■N: A2

12 Press SEQ switch. Using multiple choice entry, select shell/fuze combination. Use default shown.

SH/FZ H■ F■

13 Press SEQ switch. Using multiple choice entry, select tube elevation. Use default shown..

ELEV: 8■0

NOTE

■ For 60mm, 81mm, or 120mm, enter charge (CHG). When charge is not entered MBC will enter charge.

14 Press SEQ switch.

READY

MANUAL INPUT MISSIONS (CONT)

COMPUTE

Use COMPUTE switch to start computation of the fire mission data and view fire commands for the selected weapons. When method of control is FFE or DST, fire commands are displayed for each assigned weapon. The following displays show the minimum fire commands sent to the weapons. Safety violation data is also shown in the second display for the FDC when applicable.

NOTE

After warning messages for FIRE LN VIOL, ZN # VIOL, FC # DANGER, AND/OR GUN # DANGER is displayed, an option to override this violation(s) is provided. "YES" will override the warning and the fire order is displayed. "NO" will put MBC to READY without displaying the gun order.

If the violations mentioned above involve multiple guns, a warning message and an override option will redisplayed for every gun that violates. If "YES" is selected to override the warning for a particular gun, the fire order of that gun is displayed and the information for the next gun (if any) follows. If "NO" is selected (not to override the warning for a particular gun), the MBC will go to READY for a prepared new task without providing any information for the next gun (if any).

DISPLAY

- 15 Press COMPUTE switch. (Method of control used, type MET used, and registration point when used)

AF	CURR	RP: __
----	------	--------

- 16 Press SEQ switch. (Fire line violation) Proper clearance should be obtained before continuing the mission.

AZ	FIRE	LN	VIOL
----	------	----	------

MANUAL INPUT MISSIONS (CONT)

DISPLAY

- 16.1 Press SEQ switch.
- 16.2 If alarm is on in setup menu, unit will beep at this menu until any key is pressed.
- 16.3 Pressing "YES" will continue with mission. Pressing "NO" will return to READY menu.
- 17 Press "YES." (Weapon, deflection, and charge)

NO OVERRIDE YES



AZDF:3842CH:26\6

Press SEQ switch. (Weapon, fuze setting when applicable, and elevation)

AZFS:___EL:0800

MANUAL INPUT MISSIONS (CONT)

DISPLAY

19 Press SEQ switch.
(Weapon and time of flight)

A2 TOF:30.8

20 Press SEQ switch.

READY

XMIT

Use XMIT switch in manual operation to display the message to observer (MTO). The number of volleys, number of units, shell/fuze combination, and firing information are operator entered for fire for effect. Use (MTO) selection to format the message. Read the information to the forward observer.

21 Press XMIT switch.

MEO CDD

22 Using multiple choice entry, select message to observer (MTO). (Mission and target number entered by computer)

MSN:1 TN:AH0001

23 Press SEQ switch.
(Adjusting weapon entered by computer)

ADJ WPN:A2

24 Press SEQ switch. Press CLEAR ENTRY switch. Using numeric entry, enter number of volleys for fire for effect. Enter 03.

NR VOL:03

MANUAL INPUT MISSIONS (CONT)

DISPLAY

25 Press SEQ switch. Press CLEAR ENTRY switch. Using numeric entry, enter number of units to fire for effect. Enter 04.

NR UNITS: 04

26 Press SEQ switch. (Probable error entered by computer)

PR ERR: NOTGUN

27 Press SEQ switch. (Adjusting shell/fuze entered by computer)

ADJ SF: HEQ

28 Press SEQ switch. (Shell/fuze for first round for FFE entered by computer)

1ST SF: NOPR

29 Press SEQ switch. (Shell/fuze for subsequent rounds for FFE entered by computer)

SUBS SF: NOPR

30 Press SEQ switch. Select method of engagement. Use default shown.

MOE: H1 D0

31 Press SEQ switch. Select method of control. Use default shown.

CON: WR AF

MANUAL INPUT MISSIONS (CONT)

DISPLAY

32 Press SEQ switch. (Time of flight entered by computer)

TOF:030

33 Press SEQ switch. (Angle T entered by computer)

ANG T:0400MILS

NOTE

There are additional displays used for digital communication, but not used in manual operations. Proceed with adjustment.

ADJ

Use ADJ switch to enter observer corrections for adjustment of burst location. Corrections apply to observer to target direction. ADJ switch allows two types of registration.

(1) Normal adjust (ADJ) using inputs from one forward observer.

(2) Mean point of impact (MPI) using inputs from two forward observers.

Inputs are left or right deviation and plus or minus range. Height adjustment in meters or feet may also be entered for air bursts or targets located on a hill.

When MPI is used the first FO data entered is vertical angle (VA) and azimuth to target. The second FO data entered is azimuth only.

If WPN AMMO data and TFC data are suitable, COMPUTE switch may be used after entry of adjust data.

The following displays show data for the first adjustment for the Sample Grid Fire Mission (Left 200, Add 300).

MANUAL INPUT MISSIONS (CONT)

DISPLAY

34 Press ADJ switch.

ADJ MFI

35 Using multiple choice entry,
select mission type. Select ADJ.

ENT REV

36 Using multiple choice entry,
select ENT for the initial
adjustment. (Adjusting FO
identification)

ADJUST FO:B/01\-

37 Press SEQ switch. (Mission and
target number entered by
computer)

MSN:1 TN:AH0001

38 Press SEQ switch. (Availability
of registration data YES/NO)

REG/MET: YES

39 Press SEQ switch.

RP: _ _

MANUAL INPUT MISSIONS (CONT)

DISPLAY

40 Press SEQ switch. (Observer to target direction entered by computer)

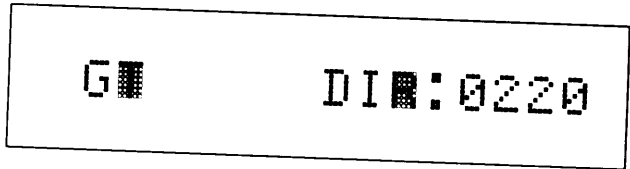

41 Press SEQ switch. Using direction and numeric entry, enter L or R and deviation in roils. Enter L0200.

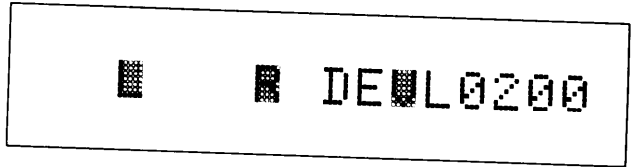

42 Press SEQ switch. Using direction and numeric entry, enter + or - and range correction in meters. Enter +0300.

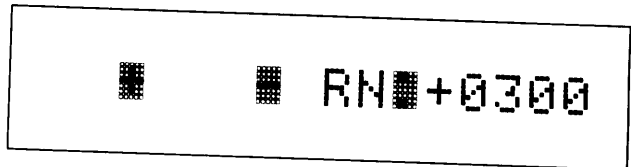

43 Press SEQ switch. The default burst height correction entry is in meters and may be changed to feet using multiple choice entry.

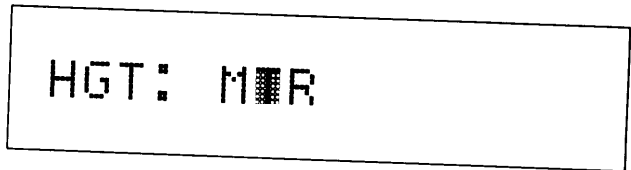

44 Press SEQ switch. Using direction and numeric entry, enter height correction when needed.

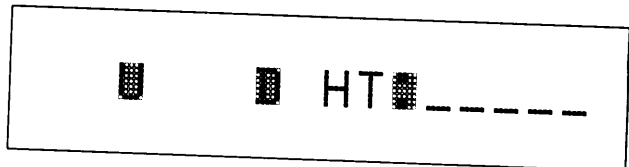

45 Press SEQ switch.

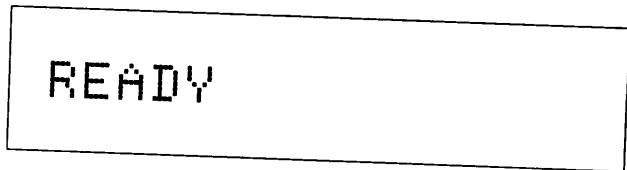

MANUAL INPUT MISSIONS (CONT)

COMPUTE FIRE COMMANDS FOR SECOND ROUND

DISPLAY

46 Press COMPUTE switch. (Method of control used, type MET used, and registration point when used)

AF CURR RP:--

47 Press SEQ switch. (Fire line violation) Proper clearance should be obtained before continuing the mission.

A2 FIRE LN VIOL

47.1 Press SEQ switch.

47.2 Pressing "YES" will continue with mission. Pressing "NO" will return to READY menu.

NO OVERRIDE YES

48 Press "YES." (Weapon, deflection, and charge)

A2DF:3857CH:29\5

49 Press SEQ switch. (Weapon, fuze setting when applicable, and elevation)

A2FS:---EL:0800

50 Press SEQ switch. (Weapon and time of flight)

A2 TOF:32.3

MANUAL INPUT MISSIONS (CONT)

DISPLAY

51 Press SEQ switch.

READY

NOTE

Send fire commands to guns, (guns fire), SHOT/SPLASH are sent to the FO. Hereafter, SHOT/SPLASH and fire commands are to be sent after each computed adjustment.

ENTER ADJUSTMENTS TO SECOND ROUND: RIGHT 50, ADD 100

52 Press ADJ switch.

ADJ M I

53 Using multiple choice entry, select mission type. Select ADJ.

ENT R U

54 Using multiple choice entry, select ENT to enter adjustments. (Adjusting FO identification)

ADJUST FO: B/01 \-

MANUAL INPUT MISSIONS (CONT)

DISPLAY

55 Press SEQ switch. (Mission and target number entered by computer)

MSN: 1 TN: AH0001

56 Press SEQ switch. (Availability of registration data YES/NO)

REG/MET: YES

57 Press SEQ switch.

RP: __

58 Press SEQ switch. (Observer to target direction entered by computer)

G DI: 0220

59 Press SEQ switch. Using direction and numeric entry, enter L or R and deviation in mils. Enter R0050.

 DE R0050

MANUAL INPUT MISSIONS (CONT)

DISPLAY

60 Press SEQ switch. Using direction and numeric entry, enter + or - and range correction in meters. Enter +0100.

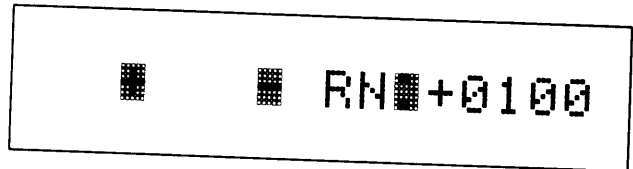

61 Press SEQ switch. The default for burst height correction is in meters and may be changed to feet using multiple choice entry.

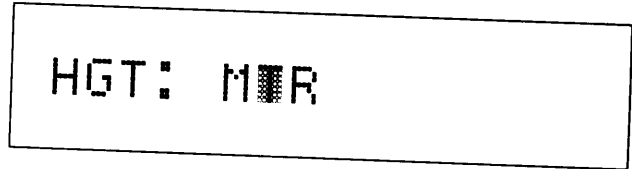

62 Press SEQ switch. Using direction and numeric entry, enter height correction when needed.

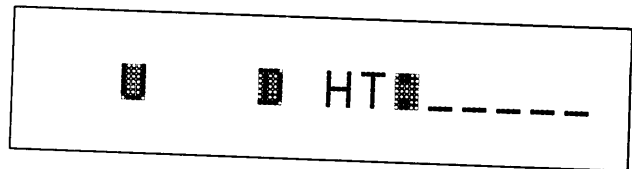

63 Press SEQ switch.

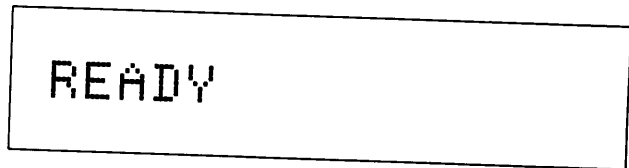

COMPUTE FIRE COMMANDS FOR THIRD ROUND

64 Press COMPUTE switch. (Method of control used, type MET used, and registration point when used)

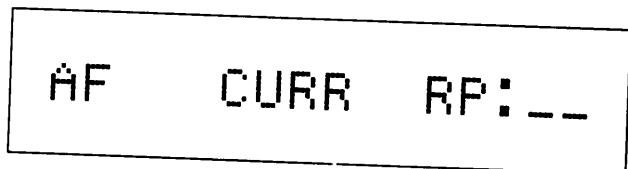

MANUAL INPUT MISSIONS (CONT)

DISPLAY

65 Press SEQ switch. (Fire line violation) Proper clearance should be obtained before continuing the mission.

A2 FIRE LN VIOL

65.1 Press SEQ switch.

NO OVERRIDE YES



65.2 Pressing "YES" will continue with mission. Pressing "NO" will return to READY menu.

66 Press "YES." (Weapon, deflection, and charge)

A2DF:3837CH:30\2

67 Press SEQ switch. (Weapon, fuze setting when applicable, and elevation)

A2FS:___EL:0800

68 Press SEQ switch. (Weapon and time of flight)

A2 TOF:32.6

69 Press SEQ switch.

READY

MANUAL INPUT MISSIONS (CONT)

ENTER ADJUSTMENTS TO THIRD ROUND: DROP 50, FFE

DISPLAY

70 Press ADJ switch.

ADJ MI

71 Using multiple choice entry,
select mission type. Select ADJ.

ENT REV

72 Using multiple choice entry,
select ENT to enter adjustments.
(Adjusting FO identification)

ADJUST FO: B/01 \-

73 Press SEQ switch. (Mission and
target number computer assigned)

MSN: 1 TN: AH0001

74 Press SEQ switch. (Availability
of registration data YES/NO)

REG/MET: YES

MANUAL INPUT MISSIONS (CONT)

DISPLAY

75 Press SEQ switch.

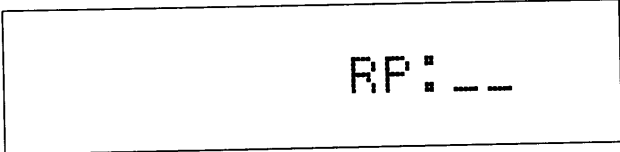

76 Press SEQ switch. (Observer to target direction entered by computer)

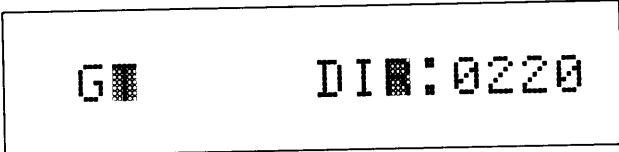

77 Press SEQ switch. Using direction and numeric entry, enter L or R and deviation in roils when needed.

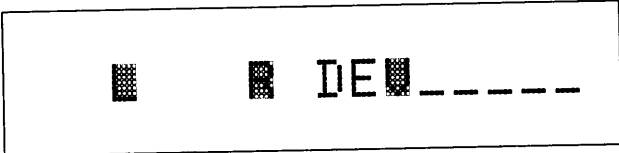

78 Press SEQ switch. Using direction and numeric entry, enter + or - and range correction in meters. Enter -0050.

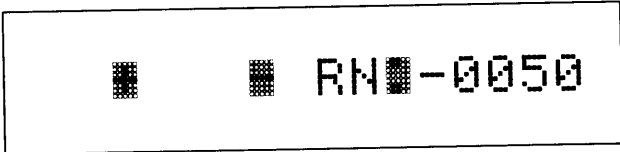

79 press SEQ switch. The default for burst height correction is in meters and may be changed to feet using multiple choice entry.

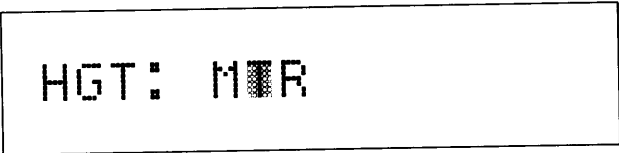

MANUAL INPUT MISSIONS (CONT)

DISPLAY

80 Press SEQ switch. Using direction and numeric entry, enter height correction when needed.

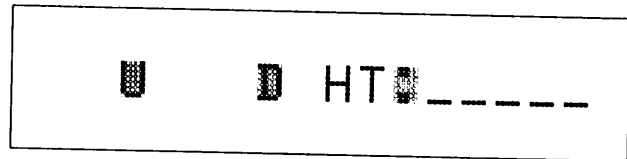

81 Press SEQ switch.

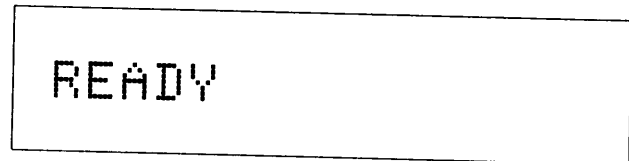

TFC

Use TFC switch to enter or change information for the following: sheaf, method of control, weapons to fire, and select registration or MET data. If you have no changes, MBC will default to: parallel sheaf, control of adjust fire, weapons selected with the WPN AMMO switch, registration, or MET data. Sheaf types are parallel, converge, and special. TFC switch is not needed when all these defaults are acceptable. In the Sample Grid Fire Mission forward observer 1 requested fire for effect.

NOTE

In adjust fire only one weapon, selected by the WPN AMMO switch, will be used. When entering fire-for effect, all assigned weapons in a section will be included for computation.

82 press TFC switch. (FO ID number entered by computer)

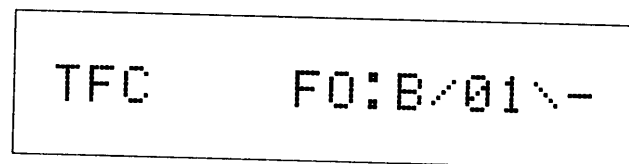

MANUAL INPUT MISSIONS (CONT)

DISPLAY

83 Press SEQ switch. (Mission and target number entered by computer)

MSN: 1 TN: AH0001

84 Press SEQ switch. Select type of sheaf; parallel (PRL), converge (CVG), or special (SPECIAL). Use default shown.

SHEAF: PRL

85 Press SEQ switch. Using multiple choice entry, select method of control; adjust fire (AF), fire for effect (FFE), destruction (DST), or registration (REG). Select FFE.

CON: FFE

86 Press SEQ switch. (Section and weapons entered by computer)

GUNS: A2 034__

NOTE

When control is FFE or DT, some weapons may be deleted by using correction entry.

87 Press SEQ switch.

REG/MET: YES

MANUAL INPUT MISSIONS (CONT)

DISPLAY

88 Press SEQ switch.

RP: __

89 Press SEQ switch.

PUSH COMPUTE

COMPUTE FINAL ADJUSTMENT

90 Press COMPUTE switch. (Method of control used, type MET used, and registration point when used)

FFE CURR RP: __

91 Press SEQ switch. (Fire line violation) Proper clearance should be obtained before continuing the mission.

A1 FIRE LN VIOL

91.1 Press SEQ switch.

NO OVERRIDE YES



91.2 Pressing "YES" will continue with mission. Pressing "NO" will return to READY menu.

92 Press "YES." (Weapon, deflection, and charge)

A1DF:3842CH:29\7

MANUAL INPUT MISSIONS (CONT)

DISPLAY

93 Press SEQ switch.
(Weapon, fuze setting when applicable and elevation)

A1FS: _ _ _ _ EL: 0800

94 Press SEQ switch.
(Weapon and time of flight)

A1 TOF: 32.4

95 Press SEQ switch.
(Fire line violation)
Proper clearance should be obtained before continuing the mission.

A2 FIRE LN VIOL

95.1 Press SEQ switch.

NO OVERRIDE YES

95.2 Pressing "YES" will continue with mission. Pressing "NO" will return to READY menu.

96 Press "YES." (Weapon, deflection, and charge)

A2DF: 3842CH: 29\7

97 Press SEQ switch.
(Weapon, fuze setting when applicable, and elevation)

A2FS: _ _ _ _ EL: 0800

98 Press SEQ switch.
(Weapon and time of flight)

A2 TOF: 32.4

MANUAL INPUT MISSIONS (CONT)

DISPLAY

99 Press SEQ switch.
(Fire line violation)
Proper clearance should
be obtained before continuing
the mission.

A3 FIRE LN VIOL

99.1 Press SEQ switch.

99.2 Pressing "YES" will continue with
mission. Pressing "NO" will return to
READY menu.



NO OVERRIDE YES

100 Press "YES." (Weapon, deflection, and
charge)

A3DF:3842CH:29\7

101 Press SEQ switch. (Weapon, fuze
setting when applicable, and
elevation)

A3FS:___EL:0000

102 Press SEQ switch. (Weapon and
time of flight)

A3 TOF:32.4

103 Press SEQ switch. (Fire line
violation) Proper clearance
should be obtained before
continuing the mission.

A4 FIRE LN VIOL

MANUAL INPUT MISSIONS (CONT)

103.1 Press SEQ switch.



NO OVERRIDE YES

103.2 Pressing "YES" will continue with mission. Pressing "NO" will return to READY menu.

104 Press "YES." (Weapon, deflection, and charge)

A4DF:3842CH:29\7

105 Press SEQ switch. (Weapon, fuze setting when applicable, and elevation)

A4F5:___EL:0800

MANUAL INPUT MISSIONS (CONT)

DISPLAY

106 Press SEQ switch. (Weapon and time of flight)

A4 TOF:32.4

107 Press SEQ switch.

NOTE

In addition to SHOT/SPLASH, "Rounds Complete" is also sent to the FO.

READY

MSN

Use MSN switch to review current active fire mission data and to specify which mission is operational. The MBC can store data for three active fire missions and compute fire commands for one operational mission. A mission and target number are computer-assigned to a mission each time the GRID, SHIFT, or POLAR switch is pressed. To avoid misuse of target numbers from the target numbering block, use these switches only when starting a fire mission. Access GRID, SHIFT, or POLAR data through the MSN switch. Only an operational mission allows entry or change of data for that mission. A mission must be in operational status before inputs can be applied from the WPN AMMO, REG, TFC, SFTY DATA, EOM, and REPLOT switches.

108 Press MSN switch. Mission 1 is Grid and operational, Missions 2 and 3 are unassigned. Operational mission number is displayed at far right. Use SEQ switch to review message that started the mission. Displayed data is in FR GRID, FR SHIFT, or FR POLAR message format.

1GAD 2UNA 3UNA 1

MANUAL INPUT MISSIONS (CONT)

DISPLAY

109	Press SEQ switch.	FR GRID
110	Press SEQ switch. (FO Identification)	FO:B/01\-
111	Press SEQ switch. (Mission and target number entered by computer)	MSN:1 TN:AH0001
112	Press SEQ switch. (FO direction to target)	DIR:0220
113	Press SEQ switch. (Target coordinates)	E:03150 N:51000
114.	Press SEQ switch. (Target altitude)	ALT:0720
115	Press SEQ switch.	READY

MANUAL INPUT MISSIONS (CONT)

FIRE DATA

Use FIRE DATA switch to review existing fire commands. Commands from the last computed data are stored until recomputation or end of mission is processed. Data is identical to the COMPUTE switch output. Press FIRE DATA switch, use SEQ switch to sequence through stored data.

SFTY DATA

Use SFTY DATA switch to review safety factors for the sample Grid Fire Mission.

DISPLAY

- 116 Press SFTY DATA switch. (Range and azimuth from guns to target)

RN:4470 AZ:6188

- 117 Press SEQ switch. (Sequence forward for burst point)

BURST POINT SEQF

- 118 Press SEQ switch. (Burst point coordinates)

BP:E03078 N51374

- 119 Press SEQ switch. (Maximum ordinate in meters)

MAX ORD:2017

- 120 Press SEQ switch. (Time of flight in seconds)

TOF:32.4

This completes review of safety data.

MANUAL INPUT MISSIONS (CONT)

EOM

Use EOM switch to end a fire mission. Delete all data for an active mission (EOM), end the mission recording the target location (EOMRAT), or end the mission saving as final protective fire (EOMFPF). A known point may be assigned when storing the target point. For the sample Grid fire mission FO 1 requested EOMRAT.

DISPLAY

121 Press EOM switch. Using multiple choice entry, select EOM, EOMRAT, or EOMFPF. Select EOMRAT. If EOM is selected observe (READY).

EOM EOMRAT

122 Press SEQ switch. To store adjusted target impact coordinates, use-default shown. Using multiple choice entry, select YES to store initial target coordinates. Use default shown.

SURVEYED TGT:NO

123 Press SEQ switch. (Target number entered by computer) Using numeric entry, assign a known point if needed.

TN:AH0001 KP:--

124 Press SEQ switch. (Target number recorded)

TN:AH0001 SAVED

125 Press SEQ switch.

READY

MANUAL INPUT MISSIONS (CONT)**SAMPLE FPF MISSION**

SPECIAL FIRE MISSIONS

Special fire missions include registrations (REG), final protective fires (FPF), replot, and transmission (review) of the FO command (CMD) message.

TASK

Conduct and store FO number 3's final protective fire.

NOTE

The INITIALIZATION data inputs must have been previously entered into the MBC for the proper solution to be displayed.

GIVEN

FO 3 wants to establish a final protective fire. In addition, FO 3 wants to fire shell HE, fuze delay. The left limit of the FPF grid is 04240, 50930. Target altitude is 650 meters. The width of the FPF is 350 meters. The attitude is 1400 mils.

Number 1 fires and FO 3 adjusts the round Left 10, Drop 20.

Number 1 fires and FO 3 adjusts the round Left 10, Drop 10.

Number 1 fires and FO 3 indicates number 1 is adjusted, fire number 2.

Number 2 fires, FO 3 adjusts the round Left 20, Drop 20.

MANUAL INPUT MISSIONS (CONT)

Number 2 fires, and FO 3 indicates number 2 is adjusted, fire number 3.

Number 3 fires and FO 3 adjusts the round Up 10.

Number 3 fires, FO 3 indicates number 3 adjusted, fire number 4.

Number 4 fires, FO 3 adjusts the round Left 20, Add 10.

Number 4 fires, FO 3 indicates number 4 adjusted, end of mission.

SOLUTION

Perform the following switch actions using the FPF switch and GIVEN data for the FPF mission.

FPF

Use FPF switch to enter, compute, adjust, review and delete data for final protective fires (FPF). As many as 3 FPF's may be stored, and identified as line 1, 2, or 3. The stored data includes the line number and fire commands for each weapon assigned (up to 6) to the FPF line.

An FPF line is located by a set of coordinates marking the left or right limit. Then altitude, width, and attitude are entered.

When the corrections for the each adjusting weapon have been entered and recomputed they are stored and no further corrections are applied after advancing to the next weapon. The corrections made to each weapon will automatically be applied to the next weapon to be adjusted. When the last weapon in a section is adjusted, and NXT is selected, the display shows ADJ COMPLETE. After entering the FPF line, a safety fan may be entered.

MANUAL INPUT MISSIONS (CONT)

DISPLAY

- 1 Press FPF switch.

INIT ADJ DTA CLR

NOTE

The Initialization, Fire Mission, Output, and Action keys (except as directed by menus) should not be used during FPF procedures until the READY prompt appears. Use of these keys will result in de-activation of a previously active mission and may result in a loss of FPF data.

NOTE

Select INIT to clear FPF file for initial entry. Select ADJ to regain entry when (ADJ *) is missed. Select DTA to access FPF fire commands when adjustment is complete. Select CLR to clear FPF data. Select SFTY to enter safety fan.

- 2 Using multiple choice entry, select INIT. Using numeric entry enter line number 1. Using alpha and numeric entry, enter section and weapon number. Enter A1

LINE:1	WPN:A1
--------	--------

- 3 Press SEQ switch. (Shell/fuze combination entered by computer, normally not changed)

SH/FZ	H	P
-------	---	---

- 4 Press SEQ switch. Using multiple choice entry, select gun target line (GT) or using numeric entry, enter FO direction to target. Select GT.

G	DIR:GT
---	--------

MANUAL INPUT MISSIONS (CONT)

DISPLAY

5 Press SEQ switch. Using numeric entry, enter FPF left limit. Enter 04240, 50930.

E: 04240 N 50930

6 Press SEQ switch. Using numeric entry, enter altitude in meters. Enter 0650.

AL: 0650

7 Press SEQ switch. Using direction and numeric entry, enter left or right limit and FPF line width in meters. Coordinate point becomes left or right limit. Enter L350.

WID: L350

8 Press SEQ switch. Using numeric entry, enter attitude, azimuth in mils. Enter 1400 mils.

ATT: 1400

9 Press SEQ switch.

PUSH COMPUTE

MANUAL INPUT MISSIONS (CONT)

DISPLAY

- 10 Press COMPUTE switch.(Method of control used, type MET used, and registration point when used)

FFE CURR RP: __
- 11 Press SEQ switch. (Fire line violation) Proper clearance should be obtained before continuing the mission.

A1 FIRE LN VIOL
- 11.1 Press SEQ switch.



NO OVERRIDE YES
- 11.2 Pressing "YES" will continue with mission. Pressing "NO" will return to READY menu.

A1DF:3594CH:21\4
- 12 Press "YES." (Deflection and charge)

A1FS:___EL:0800
- 13 Press SEQ switch. (Fuze setting and elevation)

A2 FIRE LN VIOL
- 14 Press SEQ switch. (Fire line violation) Proper clearance should be obtained before continuing the mission.



NO OVERRIDE YES
- 14.1 Press SEQ switch.

NO OVERRIDE YES
- 14.2 Pressing "YES" will continue with mission. Pressing "NO" will return to READY menu.

NO OVERRIDE YES

MANUAL INPUT MISSIONS (CONT)

DISPLAY

- 15 Press "YES." (Deflection and charge)

A2DF:3607CH:21\3

- 16 Press SEQ switch. (Fuze setting and elevation)

A2FS:___EL:0800

- 17 Press SEQ switch. (Fire line violation) Proper clearance should be obtained before continuing the mission.

A3 FIRE LN VIOL

- 17.1 Press SEQ switch.

 NO OVERRIDE YES

- 17.2 Pressing "YES" will continue with mission. Pressing "NO" will return to READY menu.

- 18 Press "YES." (Deflection and charge)

A3DF:3622CH:21\3

- 19 Press SEQ switch. (Fuze setting and elevation)

A3FS:___EL:0800

- 20 Press SEQ switch. (Fire line violation) Proper clearance should be obtained before continuing the mission.

A4 FIRE LN VIOL

MANUAL INPUT MISSIONS (CONT)

DISPLAY

20.1 Press SEQ switch.

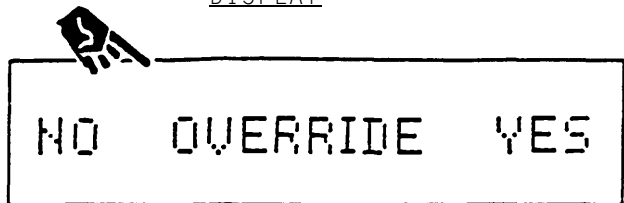

20.2 Pressing "YES" will continue with mission. Pressing "NO" will return to READY menu.

21 Press "YES." (Deflection and charge)

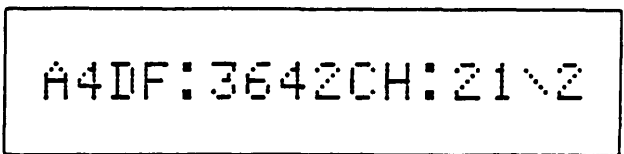

22 Press SEQ switch. (Fuze setting and elevation)

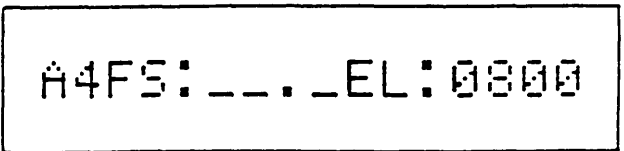

23 Press SEQ switch.

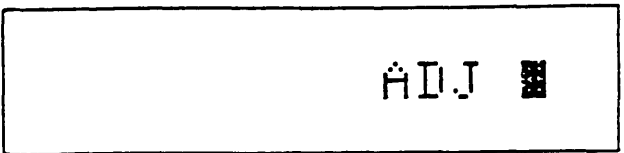

FIRST ADJUSTMENT - GUN 1, LEFT 10, DROP 20

24 Using multiple choice entry select * to adjust weapon. Using numeric entry, enter weapon number to adjust. Enter 1.



25 Press SEQ switch. (Direction to target entered by computer)

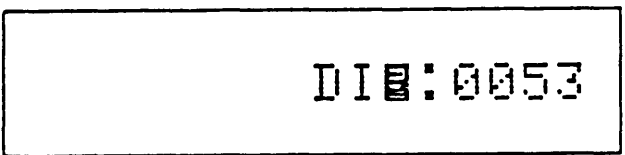

MANUAL INPUT MISSIONS (CONT)

DISPLAY

26 Press SEQ switch. Using direction and numeric entry, enter L or R and deviation, in mils. Enter L0010.

DE L0010

27 Press SEQ switch. Using direction and numeric entry, enter + or - and range correction in meters. Enter -0020.

RN -0020

28 Press SEQ switch. The default for burst height correction is in meters and may be changed to feet using multiple choice entry.

HGT: M R

29 Press SEQ switch. Using direction and numeric entry, enter height correction when needed.

HT _ _ _ _

30 Press SEQ switch.

PUSH COMPUTE

31 Press COMPUTE switch. (Method of control used, type MET used, and registration point when used)

FFE CURR RP: _ _

32 Press SEQ switch. (Fire line violation) Proper clearance should be obtained before continuing the mission.

A1 FIRE LN VIOL

MANUAL INPUT MISSIONS (CONT)

DISPLAY

- 32.1 Press SEQ switch.
- 32.2 Pressing "YES" will continue with mission. Pressing "NO" will return to READY menu.

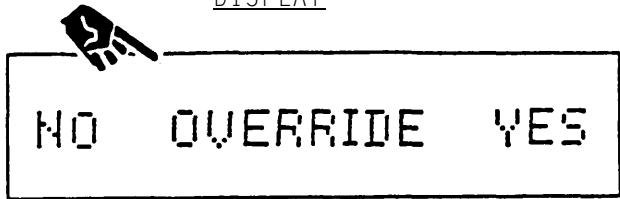

- 33 Press "YES." (Deflection and charge)

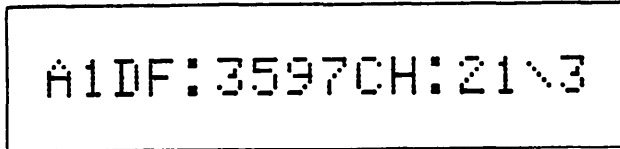

- 34 Press SEQ switch. (Fuze setting and elevation)

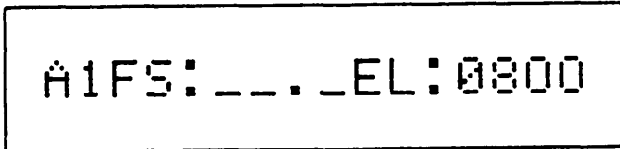

- 35 Press SEQ switch. (Fire line violation) Proper clearance should be obtained before continuing the mission.

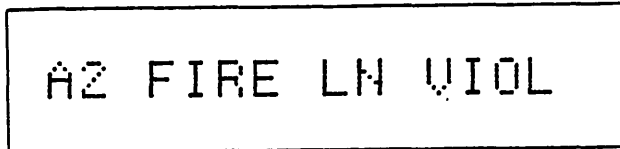

- 35.1 Press SEQ switch.

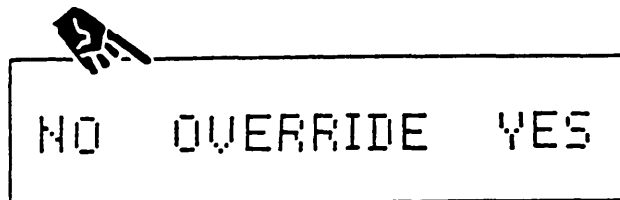

- 35.2 Pressing "YES" will continue with mission. Pressing "NO" will return to READY menu.

- 36 Press "YES." (Deflection and charge)

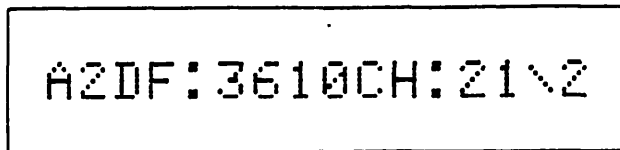

- 37 Press SEQ switch. (Fuze setting and elevation)

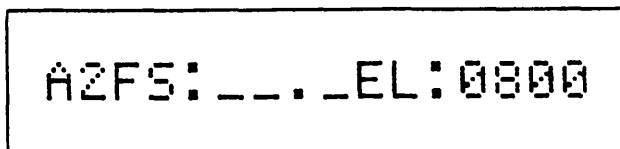

MANUAL INPUT MISSIONS (CONT)

DISPLAY

38 Press SEQ switch. (Fire line violation)
Proper clearance should be obtained
before continuing the mission.

A3 FIRE LN VIOL

38.1 Press SEQ switch.

 NO OVERRIDE YES

38.2 Pressing "YES" will continue with
mission. Pressing "NO" will return to
READY menu.

39 Press "YES." (Deflection and charge)

A3DF:3625CH:21\2

40 Press SEQ switch. (Fuze setting
and elevation)

A3FS:___EL:0800

41 Press SEQ switch. (Fire line
violation) Proper clearance
should be obtained before
continuing the mission.

A4 FIRE LN VIOL

41.1 Press SEQ switch.

 NO OVERRIDE YES

41.2 Pressing "YES" will continue with
mission. Pressing "NO" will return to
READY menu.

42 Press "YES." (Deflection and charge)

A4DF:3645CH:21\1

MANUAL INPUT MISSIONS (CONT)

DISPLAY

43 Press SEQ switch. (Fuze setting and elevation)

A4FS: _ _ _ _ EL: 0800

44 Press SEQ switch.

ADJ ■

SECOND ADJUSTMENT GUN 1, LEFT 10, DROP 10

45 Using multiple choice entry, select * to continue adjustment. Select *.

WPN: A1 C00T H0T

46 Using multiple choice entry, select CONT to continue adjustment to gun 1. (Direction to target entered by computer)

DIR: 0053

47 Press SEQ switch. Using direction and numeric entry, enter L or R and deviation in mils. Enter L0010.

■ ■ DE L0010

48 Press SEQ switch. Using direction and numeric entry, enter + or - and range correction in meters. Enter -0010.

■ ■ RM -0010

MANUAL INPUT MISSIONS (CONT)

DISPLAY

49 Press SEQ switch. The default burst height correction entry is in meters and may be changed to feet using multiple choice entry.

HGT: M R

50 Press SEQ switch. Using direction and numeric entry, enter height correction when needed.

■ ■ HT ■ _ _ _ _

51 Press SEQ switch.

PUSH COMPUTE

52 Press COMPUTE switch. (Method of control used, type MET used, and registration point when used)

FFE CURR RP: _ _

53 Press SEQ switch. (Fire line violation) Proper clearance should be obtained before continuing the mission.

A1 FIRE LN VIOL

■ **53.1** Press SEQ switch.

 NO OVERRIDE YES

■ **53.2** Pressing "YES" will continue with mission. Pressing "NO" will return to READY menu.

■ **54** Press "YES." (Deflection and charge)

A1DF:3599CH:21\3

MANUAL INPUT MISSIONS (CONT)

DISPLAY

55 Press SEQ switch. (Fuze setting and elevation)

A1FS:___EL:0800

56 Press SEQ switch. (Fire line violation) Proper clearance should be obtained before continuing the mission.

A2 FIRE LN VIOL

56.1 Press SEQ switch.

 NO OVERRIDE YES

56.2 Pressing "YES" will continue with mission. Pressing "NO" will return to READY menu.

57 Press "YES." (Deflection and charge)

A2DF:3612CH:21\2

58 Press SEQ switch. (Fuze setting and elevation)

A2FS:___EL:0800

59 Press SEQ switch. (Fire line violation) Proper clearance should be obtained before continuing the mission.

A3 FIRE LN VIOL

59.1 Press SEQ switch.

 NO OVERRIDE YES

59.2 Pressing "YES" will continue with mission. Pressing "NO" will return to READY menu.

MANUAL INPUT MISSIONS (CONT)

DISPLAY

■ 60 Press "YES." (Deflection and charge)

A3DF:3627CH:21\1

61 Press SEQ switch. (Fuze setting and elevation)

A3FS:___EL:0000

62 Press SEQ switch. (Fire line violation) Proper clearance should be obtained before continuing the mission.

A4 FIRE LN VIOL

62.1 Press SEQ switch.



62.2 Pressing "YES" will continue with mission. Pressing "NO" will return to READY menu.

NO OVERRIDE YES

■ 63 Press "YES." (Deflection and charge)

A4DF:3647CH:21\0

64 Press SEQ switch. (Fuze setting and elevation)

A4FS:___EL:0000

65 Press SEQ switch.

ADJ ■

MANUAL INPUT MISSIONS (CONT)

START ADJUSTMENT GUN 2, LEFT 20, DROP 20

DISPLAY

66 Using multiple choice entry,
select * to continue adjustment.

WPN: A1 COOT NXT

67 Using multiple choice entry,
select NXT to start adjustment to
the next weapon. Using numeric
entry, enter weapon number.
Enter 2.

WPN: A2

68 Press SEQ switch. (Gun to target
direction entered by computer)

DIR: 0053

69 Press SEQ switch. Using
direction and numeric entry,
enter L or R and deviation in
mils. Enter L0020.

DIR: L0020

70 Press SEQ switch. Using
direction and numeric entry,
enter + or - and range correction
in meters. Enter -0020.

DIR: R-0020

71 Press SEQ switch. The default
for burst height correction is in
meters and may be changed to feet
using multiple choice entry.

HGT: MFR

MANUAL INPUT MISSIONS (CONT)

DISPLAY

72 Press SEQ switch. Using direction and numeric entry, enter height correction when needed.

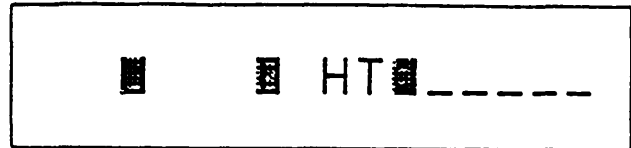

73 Press SEQ switch.

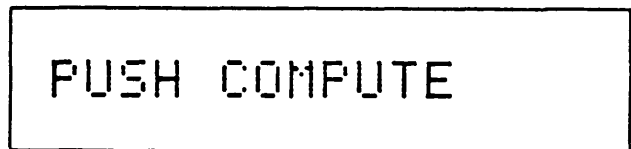

74 Press COMPUTE switch. (Method of control used, type MET used, and registration point when used)

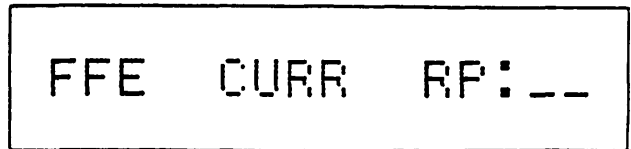

75 Press SEQ switch. (Fire line violation) Proper clearance should be obtained before continuing the mission.

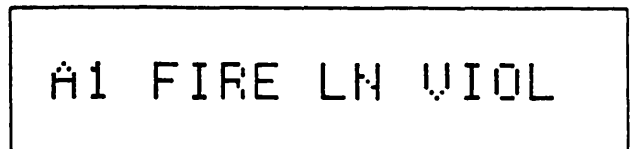

75.1 Press SEQ switch.

75.2 Pressing "YES" will continue with mission. Pressing "NO" will return to READY menu.

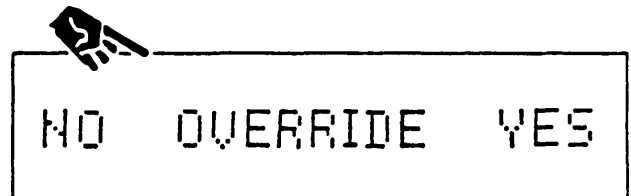

76 Press "YES." (Deflection and charge)

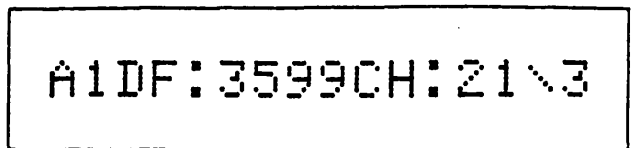

77 Press SEQ switch. (Fuze setting and elevation)

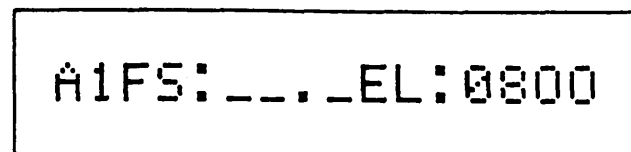

MANUAL INPUT MISSIONS (CONT)

DISPLAY

78 Press SEQ switch. (Fire line violation) Proper clearance should be obtained before continuing the mission.

A2 FIRE LN VIOL

78.1 Press SEQ switch.



NO OVERRIDE YES

78.2 Pressing "YES" will continue with mission. Pressing "NO" will return to READY menu.

79 Press "YES." (Deflection and charge)

A2DF:3617CH:21\1

80 Press SEQ switch. (Fuze setting and elevation)

A2FS:___EL:0800

81 Press SEQ switch. (Fire line violation) Proper clearance should be obtained before continuing mission.

A3 FIRE LN VIOL

81.1 Press SEQ switch.



NO OVERRIDE YES

81.2 Pressing "YES" will continue with mission. Pressing "NO" will return to READY menu.

82 Press "YES." (Deflection and charge)

A3DF:3633CH:21\0

MANUAL INPUT MISSIONS (CONT)

DISPLAY

83 Press SEQ switch. (Fuze setting and elevation)

A3FS: _ _ _ _ EL: 0800

84 Press SEQ switch. (Fire line violation) Proper clearance should be obtained before continuing the mission.

A4 FIRE LN VIOL

84.1 Press SEQ switch.

 NO OVERRIDE YES

84.2 Pressing "YES" will continue with mission. Pressing "NO" will return to READY menu.

85 Press "YES." (Deflection and charge)

A4DF: 3653CH: 21\0

86 Press SEQ switch. (Fuze setting and elevation)

A4FS: _ _ _ _ EL: 0800

87 Press SEQ switch.

ADJ 

MANUAL INPUT MISSIONS (CONT)

START ADJUSTMENT GUN 3, UP 10

DISPLAY

88 Using multiple choice entry, select * to continue adjustment.

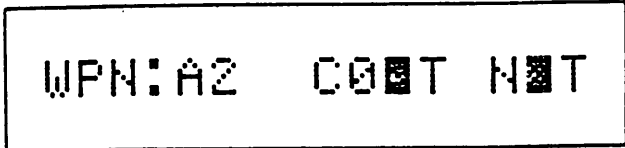

89 Using multiple choice entry, select NXT to start adjustment to the next weapon. Using numeric entry, enter weapon number. Enter 3.

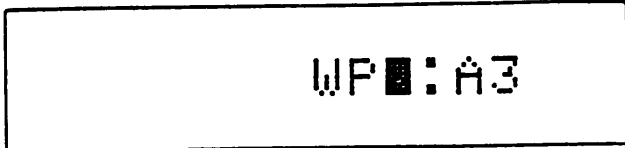

90 Press SEQ switch. (Gun to target direction entered by computer)

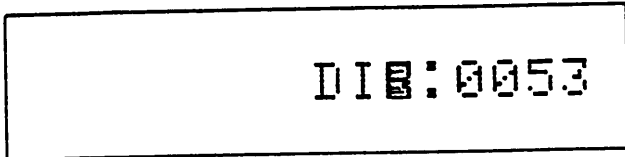

91 Press SEQ switch. Using direction and numeric entry, enter L or R and deviation in mils when needed.

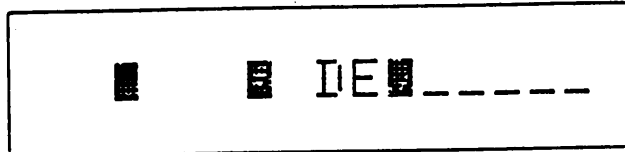

92 Press SEQ switch. Using direction and numeric entry, enter + or - and range correction when needed.



93 Press SEQ switch. The default for burst height correction is in meters and may be changed to feet using multiple choice entry.



MANUAL INPUT MISSIONS (CONT)

DISPLAY

94 Press SEQ switch. Using direction and numeric entry, enter height correction. Enter U0010.



95 Press SEQ switch.

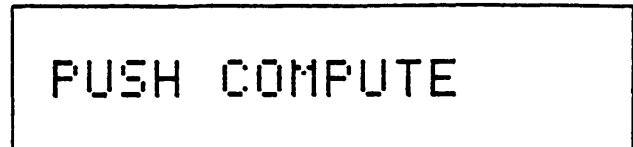

96 Press COMPUTE switch. (Method of control used, type MET used, and registration point when used)

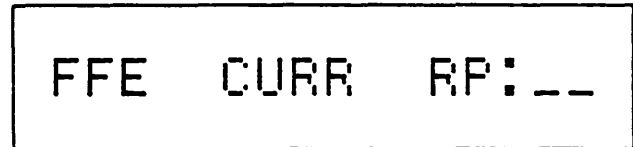

97 Press SEQ switch. (Fire line violation) proper clearance should be obtained before continuing the mission.

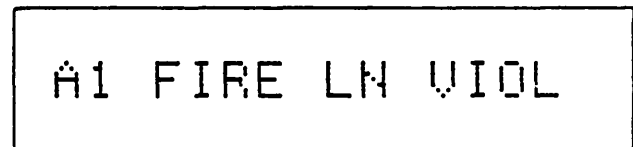

97.1 Press SEQ switch.

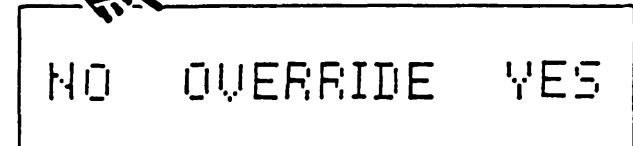

97.2 Pressing "YES" will continue with mission. Pressing "NO" will return to READY menu.

98 Press "YES." (Deflection and charge)

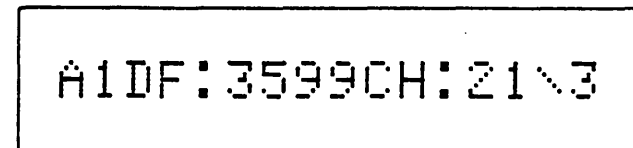

99 Press SEQ switch. (Fuze setting and elevation)

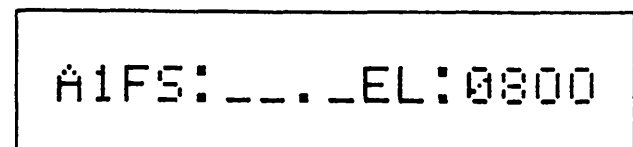

MANUAL INPUT MISSIONS (CONT)

DISPLAY

100 Press SEQ switch. (Fire line violation) Proper clearance should be obtained before continuing the mission.

A2 FIRE LN VIOL

100.1 Press SEQ switch.

 NO OVERRIDE YES

100.2 Pressing "YES" will continue with mission. Pressing "NO" will return to READY menu.

101 Press "YES." (Deflection and charge)

A2DF:3617CH:21\1

102 Press SEQ switch. (Fuze setting and elevation)

A2FS:___EL:0800

103 Press SEQ switch. (Fire line violation) Proper clearance should be obtained before continuing the mission.

A3 FIRE LN VIOL

103.1 Press SEQ switch.

 NO OVERRIDE YES

103.2 Pressing "YES" will continue with mission. Pressing "NO" will return to READY menu.

104 Press "YES." (Deflection and charge)

A3DF:3633CH:21\1

MANUAL INPUT MISSIONS (CONT)

DISPLAY

105 Press SEQ switch. (Fuze setting and elevation)

A3FS: _ _ _ _ EL: 0800

106 Press SEQ switch. (Fire line violation) Proper clearance should be obtained before continuing the mission.

A4 FIRE LN VIOL

106.1 Press SEQ switch.

NO OVERRIDE YES

106.2 Pressing "YES" will continue with mission. Pressing "NO" will return to READY menu.

107 Press "YES." (Deflection and charge)

A4DF: 3653CH: 21\0

108 Press SEQ switch. (Fuze setting and elevation)

A4FS: _ _ _ _ EL: 0800

109 Press SEQ switch.

A DJ ■

MANUAL INPUT MISSIONS (CONT)

START ADJUSTMENT GUN 4, LEFT 20, ADD 10

DISPLAY

110 Using multiple choice entry, select * to continue adjustment.

WPN: A3 C00T N0T

111 Using multiple choice entry, select NXT to start adjustment to the next weapon. Using numeric entry, enter weapon number. Enter 4.

WPN: A4

112 Press SEQ switch. (Gun to target direction entered by computer)

DIR: 0053

113 Press SEQ switch. Using direction and numeric entry, enter L or R and deviation, in mils. Enter L0020.

DIR: L0020

114 Press SEQ switch. Using direction and numeric entry, enter + or - and range correction in meters. Enter +0010.

DIR: R+0010

115 Press SEQ switch. The default for burst height correction is in meters and may be changed to feet using multiple choice entry.

HGT: M0R

MANUAL INPUT MISSIONS (CONT)

DISPLAY

116 Press SEQ switch. Using direction and numeric entry, enter height correction when needed.

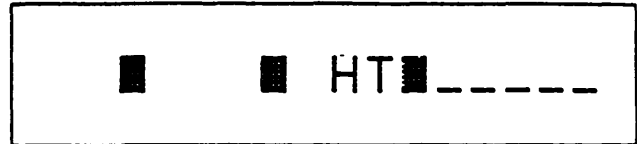

117 Press SEQ switch.

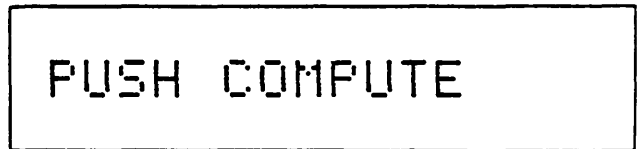

118 Press COMPUTE switch. (Method of control used, type MET used, and registration point when used)

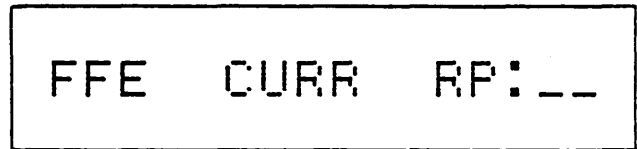

119 Press SEQ switch. (Fire line violation) Proper clearance should be obtained before continuing the mission.

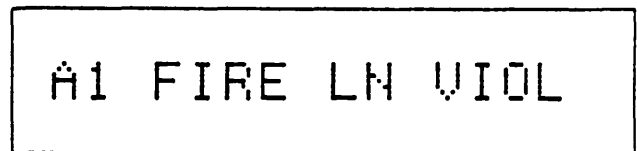

119.1 Press SEQ switch.

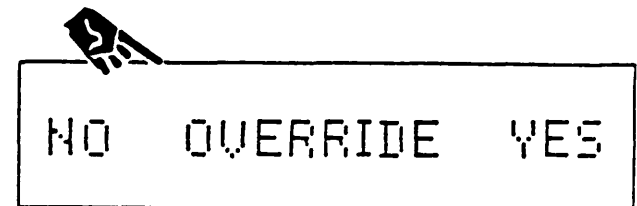

119.2 Pressing "YES" will continue with mission. Pressing "NO" will return to READY menu.

120 Press "YES." (Deflection and charge)

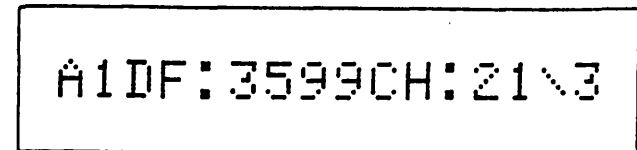

MANUAL INPUT MISSIONS (CONT)

DISPLAY

121 Press SEQ switch. (Fuze setting and elevation)

A1FS:___EL:0800

122 Press SEQ switch. (Fire line violation) Proper clearance should be obtained before continuing the mission.

A2 FIRE LN VIOL

122.1 Press SEQ switch.

122.2 Pressing "YES" will continue with mission. Pressing "NO" will return to READY menu.

 NO OVERRIDE YES
--

123 Press "YES." (Deflection and charge)

A2DF:3617CH:21\1

124 Press SEQ switch. (Fuze setting and elevation)

A2FS:___EL:0800

125 Press SEQ switch. (Fire line violation) Proper clearance should be obtained before continuing the mission.

A3 FIRE LN VIOL

MANUAL INPUT MISSIONS (CONT)

DISPLAY



125.1 Press SEQ switch.

NO OVERRIDE YES

125.2 Pressing "YES" will continue with mission. Pressing "NO" will return to READY menu.

■ 126 Press "YES." (Deflection and charge)

A3DF:3633CH:Z1\1

127 Press SEQ switch. (Fuze setting and elevation)

A3FS:___EL:0800

128 Press SEQ switch. (Fire line violation) Proper clearance should be obtained before continuing the mission.

A4 FIRE LN VIOL



128.1 Press SEQ switch.

NO OVERRIDE YES

128.2 Pressing "YES" will continue with mission. Pressing "NO" will return to READY menu.

■ 129 Press "YES." (Deflection and charge)

A4DF:3658CH:Z1\0

MANUAL INPUT MISSIONS (CONT)

DISPLAY

130 Press SEQ switch. (Fuze setting and elevation)

A4FS: _ _ _ _ EL: 0800

131 Press SEQ switch.

ADJ ■

132 Using multiple choice entry, select *.

WPN: A4 C0BT N3T

133 Using multiple choice entry, select NXT. The display momentarily shows:

ADJ COMPLETE

then shows:

READY

This completes the FPF line procedure.

DMD - SUPPORTED MISSIONS

MBC PREPARATION

When performing a DMD-supported mission perform the following OPERATIONS UNDER USUAL CONDITIONS:

ASSEMBLY AND PREPARATION FOR USE - Use a radio or field wire communications interface (a field wire interface to a DMD is shown).

INITIAL CHECKS

SELF-TEST

DMD PREPARATION

For DMD operation refer to TM 11-7440-281-12&P.

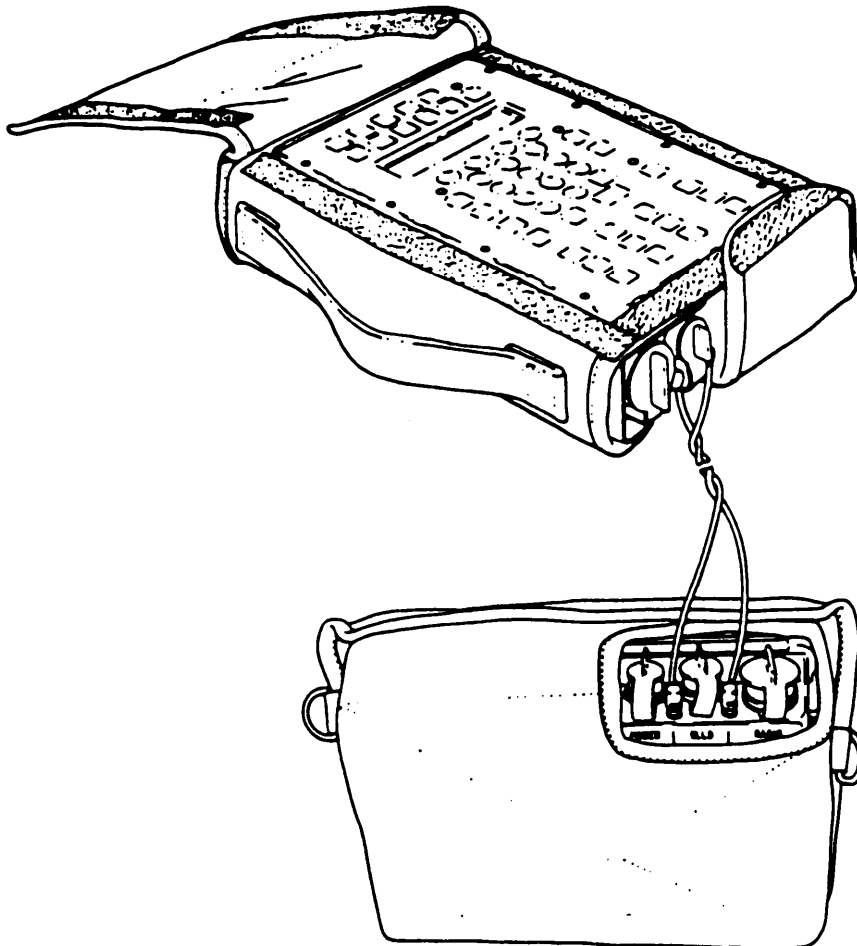

DMD - SUPPORTED MISSIONS (CONT)**GENERAL**

All DMD - supported missions occur in response to the receipt of an FO message. The input data for the mission is supplied by digital transmission from the FO DMD and is automatically entered into MBC memory.

A maximum of three incoming digital messages can be stored. Incoming messages are of two types; fire mission messages and information only messages. When the message indicator is lit or the audio alarm sounds and the MSG switch is pressed, the first line of the first message received is displayed. When the message is a fire mission, the MBC will automatically assign a mission and target number, unless three active missions have already been stored. In this case the MBC will display NO AVAIL MSN and discard the message.

When a received fire mission is accepted with mission and target numbers assigned, it automatically becomes the operational mission. Mission processing can be completed by using the WPN/AMMO switch, the TFC switch when needed, and the COMPUTE switch.

NOTE

The complete received fire mission should be reviewed before processing action is started to prevent errors in control or shell/fuze to be fired.

Fire mission data comes from the received message. The received data is in the same format as a manually entered message (GRID, SHIFT, or POLAR) and includes additional information for the operator.

DMD - SUPPORTED MISSIONS (CONT)

RECEIVED MESSAGES FOR FIRE MISSION PROCESSING AND CONTROL

The MBC is capable of receiving the following messages.

MESSAGE TYPE	MESSAGE DESCRIPTION
FR GRID	Fire request using grid coordinates
FR SHIFT	Fire request using shift from known point
FR POLAR	Fire request using polar coordinates
OBS LOC	F0 location data
SUBQ ADJ	Subsequent adjustment to fire request
SA COORDS	Subsequent adjust coordinates
PREC ADJ	Precision adjustment
FR LASER	Fire request using laser data
SA LASER	Subsequent adjustment to laser fire request.
EOM & SURV	End of mission and surveillance data
PPF	Request for final protective fire
QF KNPT	Quick fire request on a known point
QF TGT	Quick fire request on a known target
ASKNPT	F0 request to assign known point number
F0 CMD	F0 command message
HB/MPI	High burst mean point of impact
FL TRACE	Front line trace data
RDR REG	Radar registration data
FREE TEXT	Free text messages

DMD - SUPPORTED MISSIONS (CONT)

SAMPLE DMD - SUPPORTED GRID FIRE MISSION

NOTE

Before performing this sample DMD - supported mission enter INITIALIZATION data.

The data used in this SAMPLE DMD - SUPPORTED GRID FIRE MISSION is the same data used in the SAMPLE GRID FIRE MISSION, except that only one adjustment is performed. The initialization data is also identical. The MBC is connected to the DMD by field wire. The DMD ORIG is B and DEST is A. DMD communication default values are used, matching the MBC SET UP switch communication default values previously entered.

 RECEPTION OF FR GRID MESSAGE

On the DMD, compose and send an FR GRID message using the following data:

Target coordinates - EAST 03150, NORTH 51000
 Target altitude - 720
 Direction - 0220

MBC message indicator is flashing. To display the mission data-

DISPLAY

- 1 Press MSG switch.

FR GRID

- 2 Press SEQ switch. (FO authentication code and net identification)

[XX]D FO:B/00\B

DMD - SUPPORTED MISSIONS (CONT)

DISPLAY

3 Press SEQ switch. (Mission and target number are entered by computer and may vary.)

MSN:1 TN:AH0002

4 Press SEQ switch. (FO azimuth to target)

DIR:0220

5 Press SEQ switch. (Target coordinates)

E:03150 N:51000

6 Press SEQ switch. (Target altitude)

ALT:0720

NOTE

WPN AMMO, TFC, and COMPUTE switch may be used now without sequencing through the following FO information.

DMD - SUPPORTED MISSIONS (CONT)

DISPLAY

7 Press SEQ switch. (Target type and subtype)

TYPE:ARMOR APC

8 Press SEQ switch. (Degree of protection)

DOP:COVER

9 Press SEQ switch. (Radius, size of target in meters)

RAD:NOTGUN

10 Press SEQ switch. (Strength, number of target elements)

STR:NOTGUN

11 Press SEQ switch. (Requested shell and fuze)

SH/FZ:HEQ VOL: _

12 Press SEQ switch. (Requested method of control)

CON:AF

DMD - SUPPORTED MISSIONS (CONT)

DISPLAY

13 Press SEQ switch. (Requested priority level and priority zone)

PRI: NORMAL PZ_

14 Press SEQ switch.

READY

NOTE

Process the active FR GRID message by pressing WPN/AMMO switch and selecting weapons to fire. Select weapon A2. Press COMPUTE switch. Fire commands are identical to those listed on page 2-99. Send fire commands and transmit MTO as follows:

XMIT MTO

Use XMIT switch in DMD - supported missions to format and send message to observer (MTO).

15 Press XMIT switch.

MTO CMD

16 Using multiple choice entry, select message to observer (MTO). (Mission and target number entered by computer)

MSN: 1 TN: AH0002

DMD - SUPPORTED MISSIONS (CONT)

DISPLAY

17 Press SEQ switch. (Adjusting
weapon entered by computer)

ADJ WPN:A2

18 Press SEQ switch.
Using numeric entry, enter number
of volleys for fire for effect.
Enter 03.

NR VOL:03

19 Press SEQ switch. Press CLEAR
ENTRY switch. Using numeric
entry, enter number of units to
fire for effect. Enter 04.

NR UNITS:04

20 Press SEQ switch. (Probable
error entered by computer)

PR ERR:NOTGUN

21 Press SEQ switch. (Adjusting
shell/fuze entered by computer)

ADJ SF:HEQ

22 Press SEQ switch. (Shell/fuze
for first round for FFE entered
by computer)

1ST SF:NOFR

DMD - SUPPORTED MISSIONS (CONT)

DISPLAY

23 Press SEQ switch. (Shell/fuze for subsequent rounds for FFE entered by computer)

SUBS SF:NOFR

24 Press SEQ switch. (Method of engagement entered by computer)

MOE: HI DC

25 Press SEQ switch. (Method of control entered by computer)

CON: WR AF

26 Press SEQ switch. (Time of flight entered by computer)

TOF:030

27 Press SEQ switch. (Angle T entered by computer)

ANG T:0400MILS

28 Press SEQ switch. (DMD mission number entered by computer)

FO MSN:1

DMD - SUPPORTED MISSIONS (CONT)

DISPLAY

29 Press SEQ switch. (DMD identification and routing information)

FO: B/00 ROUTE B

30 Press SEQ switch. Using alpha entry, enter COMSEC code from CEOI.

[X]ID [X]MIT

31 Using multiple choice entry, select * to transmit the message. The display momentarily shows:

XMITTING

then shows: (Automatic response from DMD when message is received)

ACK

OR

(Displayed when ACK not received from DMD). As many as three tries may be attempted (changing code in step 30 after each re-try). If no response after final attempt, troubleshoot communications network.

NO RSP RE TRY 1

On the DMD, observe MTO. On the MBC, send command message SHOT SPLASH as follows:

DMD - SUPPORTED MISSIONS (CONT)

XMIT

Use XMIT switch CMD option to format and send command fire information to the FO. This includes the following data: SHOT means rounds have been fired; SPLASH means a warning to the FO, five seconds to burst; CKFR, means fire unit has received a check fire; CKFR ALL means all units received check fire; FIRE means command to fire; DESIG means designate as target; RND COMP means rounds complete; CAN CKE means cancel check fire; READY means ready to fire. The time period between the SHOT and SPLASH message is automatically computed. The following example digitally transmits the command SHOT SPLASH message to the FO.

DISPLAY

32 Press XMIT switch.

MTO CMD

33 Using multiple choice entry, select CMD. (Mission and target number entered by computer)

MSN: 1 TN: AH0002

34 Press SEQ switch. Using multiple choice entry, select type of firing information. Choices are SHOT, SPLASH, DESIG, FIRE, CKFR, CKFR ALL, and READY. Use default shown.

FI INFO: SHOT

35 Press SEQ switch. Using multiple choice entry, select DIGITAL for automatic transmission of SHOT SPLASH. Select MANUAL when sending SHOT SPLASH by voice. Select DIGITAL.

DIGITAL MANUAL

36 Press SEQ switch. (DMD identification and routing information)

FO: B/00 ROUTE: B

DMD - SUPPORTED MISSIONS (CONT)

DISPLAY

- 37 Press SEQ switch. Using alpha entry, enter COMSEC code from CEOI to transmit SHOT.

[XX]D SHOT

- 38 Press SEQ switch. Using alpha entry, enter COMSEC code from CEOI to transmit SPLASH.

[XX]D SPLASH

- 39 Press SEQ switch.

*XMIT

- 40 Using multiple choice entry, select * to transmit SHOT message. (Displayed until time to send SPLASH message)

XMITTING

then momentarily shows:

SPLASH

then momentarily shows:

XMITTING

DMD - SUPPORTED MISSIONS (CONT)

DISPLAY

then shows:
(Automatic response from DMD
when message is received)

ACK

OR

(Displayed when ACK not
received from DMD)
As many as three tries
may be attempted (changing
code in step 37 after each
retry). If no response after
final attempt, troubleshoot
communications network.

NO RSP REPLY 1

RECEPTION OF SUBQ ADJ MESSAGE

On the DMD, compose and send SUBQ ADJ message using the following data:

LFT 200
ADD 300

MBC message indicator is flashing. To display the mission data -

41 Press MSG switch.

SUBQ ADJUST

DMD - SUPPORTED MISSIONS (CONT)

DISPLAY

42 Press SEQ switch. (FO authentication code and net identification)

[XX]D FO:B/00\B

43 Press SEQ switch. (Mission and target numbers)

MSN:1 TN:AH0002

44 Press SEQ switch. (FO azimuth to target)

DIR:0220

45 Press SEQ switch. (Direction left or right and amount of shift in meters)

DEV:L0200

46 Press SEQ switch. (Range add or drop and amount of change in meters)

RN:+0300

47 Press SEQ switch. (Height up or down and amount of change in meters)

HGT:_____

DMD - SUPPORTED MISSIONS (CONT)

DISPLAY

48 Press SEQ switch.
(Target position adjustment information)

OBSN:OK

49 Press SEQ switch.
(FO requested shell/fuze, information only)

SH/FZ:HEQ

50 Press SEQ switch.
(FO requested method of control, information only)

CON:AF

51 Press SEQ switch.
Using multiple choice entry, select ADJUST to enter corrections. Select CLEAR to delete message. Select END to retain the message, without processing the data.

ADJUST CLEAR END

Perform adjustments as received during adjustment phase.

READY

REMOVING FROM OPERATION

Turn off MBC and disconnect interface cable. Return MBC and cable to carrying case.

PREPARATION FOR MOVEMENT

Remove battery before shipment or inactive storage.

Section IV. OPERATION UNDER UNUSUAL CONDITIONS

OPERATION IN UNUSUAL WEATHER

The MBC will operate in extreme weather conditions; from a minimum temperature of -40 degrees F to a maximum of +159 degrees F.

EXTREME HEAT. With temperatures 110 degrees F and higher, some overhead cover should be used whenever possible to reduce heat buildup on the equipment.

EXTREME COLD. With temperatures 0 degrees F and lower, a wind screen should be used to protect the operator and the MBC from wind-chill effects.

FLYING SAND AND DUST. Under conditions of flying sand or dust a wind screen should be used.

FORDING AND SWIMMING OPERATIONS

The MBC is designed to operate after 2 hours under 3 feet of water. If the MBC has been totally immersed, the battery compartment should be checked for moisture and the complete unit thoroughly dried with a soft cloth. If available, a waterproof plastic bag should be used to cover the MBC during fording operations.

EMERGENCY PROCEDURES

If the modem fails, the MBC will be unable to accept digital messages from DMD-equipped forward observers. If the MBC cannot be replaced immediately, use voice communication with the forward observer and input fire requests and adjustments using the manual input menus.

CHEMICAL DECONTAMINATION PROCEDURES

NOTE

Detailed DECON procedures can be found in FM 3-87 and FM 3-5.

Use M8 or M9 paper from the M256 Chemical Kit to determine if a liquid chemical agent is on the equipment surface.

If exposure to liquid agent is known or suspected, clean exposed skin, clothing, and personal gear, in that order, using M258A1 Kit. Use the buddy system. Wash exposed skin and thoroughly decontaminate as soon as tactical situation permits.

When the M8 or M9 paper indicates liquid chemical agent is on the equipment, use the M258A1 decon kit for partial decontamination of MBC.

Remove number 1 decon packet from M258A1 kit, fold on solid line, tear open quickly at notch, remove pad, unfold fully, and wipe surface of MBC for about 1 minute.

Remove number 2 decon packet from M258A1 kit, crush ampoules, fold on solid line, tear open quickly at notch, remove pad, letting screen fall away, and wipe surface of MBC for 2 to 3 minutes.

Decontamination procedures take time. Do as much as you can based on the tactical situation.

JAMMING AND ECM PROCEDURES

Electronic warfare includes the use of noise or static (jamming) on the radio frequencies to interfere or prevent communication. The MBC has one device to limit effects of jamming. Follow CEOI standard procedures.

BIT RATE. The bit rate can be used at 600 bits per second or can be increased to 1200 bits per second to transmit faster.

CHAPTER 3

OPERATOR MAINTENANCE

	Page
Operator Maintenance	3-1
Lubrication Instructions	3-1
Troubleshooting Procedures	3-1
Maintenance Procedures	3-1

Section I. LUBRICATION INSTRUCTIONS

LUBRICATION INSTRUCTIONS

The MBC requires no lubrication.

Section II. TROUBLESHOOTING PROCEDURES

TROUBLESHOOTING PROCEDURES

Troubleshooting is limited to performing the MBC Self-Test as directed in Chapter 2, Section III.

Section III. MAINTENANCE PROCEDURES

INTRODUCTION

Operator maintenance is confined to inspection, cleaning, battery replacement, and performing the MBC Self-Test.

INSPECTION

Perform inspection as listed in the PMCS Table equipment inspection entries in Chapter 2, Section II.

CHECKS/ADJUSTMENTS

Perform PMCS including MBC Self-Test as described in Chapter 2, Section III.

REMOVAL AND INSTALLATION

Removal and installation is confined to replacement to type BA-5588/U and BA-1588/U batteries as described in Chapter 2, Section III.

DISASSEMBLY AND ASSEMBLY

No disassembly or assembly of the MBC is authorized.

REPAIR

Repair of MBC is restricted to battery replacement.

CLEANING

- Check outside surfaces of MBC case, display, keyboard, and indicators.
- Remove dust and loose dirt with clean, soft, non-abrasive, dry cloth (item 3, Appendix D).
- Remove grease, fungus, and ground-in dirt from MBC outside case surfaces with a damp cloth and mild soap (if required). Wipe with clean dry cloth.
- Remove dust or dirt from MBC connectors with a stiff bristle brush (item 2 Appendix D).

CLEANING (CONT)

- Remove dust or dirt from radio cable plugs and power cable plugs and clamps with a stiff bristle brush.
- Clean keyboard, display, and indicators with soft, clean, cloth dampened with water (use mild soap if required). After cleaning off dirt, wipe MBC with clean, dry cloth.
- Clean battery leaks (chemical) from battery compartment and battery compartment cover with cloth dampened with water (use mild soap if required). Wipe with clean dry cloth. Dry deposits should be removed with stiff bristle brush. (Do not use a wire bristle brush.)
- Clean carrying case, straps, and field case by allowing mud to dry, then brush and scrape off with stiff bristle brush. Remove grease (use mild soap).

TEST

Testing is confined to performing the MBC Self-Test as described in Chapter 2, Section III.

CHAPTER 4

ORGANIZATIONAL MAINTENANCE

	Page
ORGANIZATIONAL MAINTENANCE	4-1
Repair Parts, Special Tools, TMDE, and Support Equipment	4-1
Service Upon Receipt	4-2
Organizational Preventive Maintenance Checks and Services (PMCS)	4-2
Troubleshooting	4-3
Maintenance Procedures	4-4
Preparation for Storage or Shipment	4-6

Section I. REPAIR PARTS, SPECIAL TOOLS, TMDE,
AND
SUPPORT EQUIPMENT

COMMON TOOLS AND EQUIPMENT

Refer to Modified Table of Organization and Equipment (MTOE).

SPECIAL TOOLS, TMDE, AND SUPPORT EQUIPMENT

At organizational level, no special tools or support equipment are required for maintenance.

REPAIR PARTS

Repair parts are listed and illustrated in Appendix E, Repair Parts and Special Tools List (RPSTL) of this manual.

Section II. SERVICE UPON RECEIPT

SERVICE UPON RECEIPT OF MATERIEL

Reusable containers are not used. A sequence for unpacking is not required.

Checking Unpacked Equipment

- Inspect the equipment for damage incurred during shipment. If the equipment has been damaged, report the damage on SF Form 364, Report of Discrepancy (ROD).
- Check the equipment against the packing slip to see if the shipment is complete. Report all discrepancies in accordance with the instructions of DA PAM 738-750.
- Check to see whether the equipment has been modified.

INSTALLATION INSTRUCTIONS

Refer to Assembly and Preparation For Use in Chapter 2, Section III.

PRELIMINARY SERVICING AND ADJUSTMENT OF EQUIPMENT

Perform PMCS and MBC Self-Test as described in Chapter 2, Sections II and III. There are no adjustments on the MBC.

SECTION III. ORGANIZATIONAL PREVENTIVE MAINTENANCE CHECKS AND SERVICES (PMCS)

INTRODUCTION

Perform Operator PMCS monthly. Refer to Chapter 2. Section II.

Section IV. TROUBLESHOOTING

GENERAL

Organizational troubleshooting is confined to performing Self-Test and physical inspection.

SELF-TEST

Refer to MBC Self-Test as described in Chapter 2, Section III. Corrective measure for failure to pass Self-Test is to return MBC to next higher maintenance level.

PHYSICAL INSPECTION

Refer to Organizational PMCS Table equipment inspection entries in Chapter 4, Section III. Perform authorized organizational maintenance (corrective measure) resulting from physical inspection as described in Chapter 4, Section V, Maintenance procedures.

For repair of physical deficiencies beyond the scope of organizational maintenance return MBC to next higher maintenance level.

Section V. MAINTENANCE PROCEDURES

OPERATIONAL CHECK

Refer to MBC Self-Test as described in Chapter 2, Section III. If MBC fails to pass Self-Test return MBC to next higher maintenance level.

REPAIR OR REPLACEMENT

Perform any of the following corrective measures indicated by organizational troubleshooting.

REPLACEMENT OF TYPE BB-588/U BATTERY

Perform replacement of battery as described in Chapter 2, Section III.

REPAIR OR REPLACEMENT (CONT)

REPLACEMENT OF CARRYING CASE

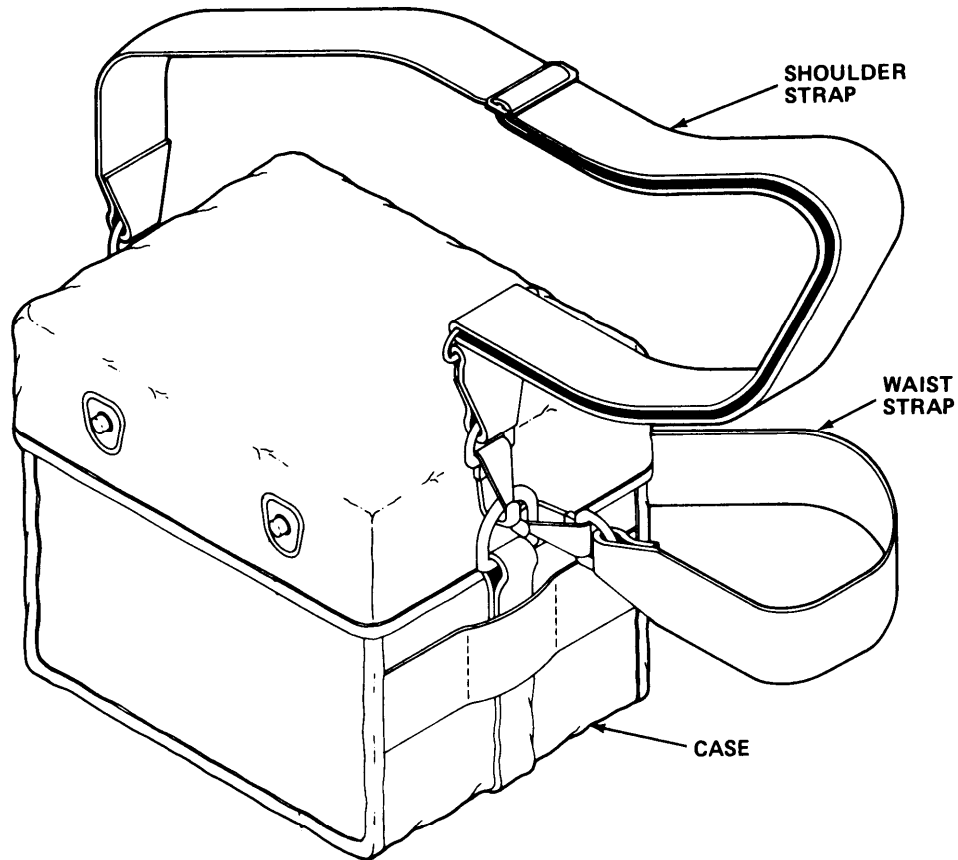

Discard the carrying case (consisting of case, waist strap, and shoulder strap) and replace with a good carrying case.

REPAIR OR REPLACEMENT (CONT)

REPLACEMENT OF INTERCONNECTING CABLES

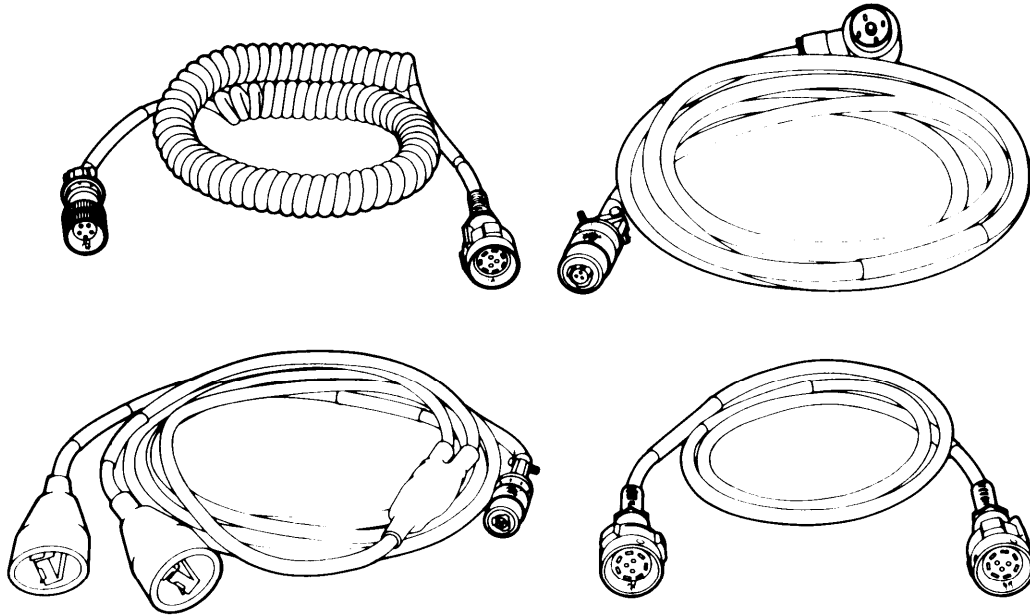

Return suspected faulty interconnecting cables to next higher maintenance level for repair.

Section VI. PREPARATION FOR STORAGE OR SHIPMENT

ADMINISTRATIVE STORAGE

- The MBC will be cleaned as specified in the maintenance instructions (pages 3-2, 3-3)
- Administrative storage of the MBC will be in accordance with TM 740-90-1.
- Remove the battery.

APPENDIX A

REFERENCES

A-1. SCOPE

This appendix lists all forms, field manuals, technical manuals, and army regulations referenced in this manual.

A-2. FORMS

Equipment Inspection and Maintenance Worksheet DA Form 2404

Quality Deficiency Report SF 368

Recommended Changes to DA Publications DA Form 2028-2

Report of Discrepancy (ROD) SF Form 364

A-3. FIELD MANUALS

First Aid for Soldiers FM21-11

NBC Decontamination FM 3-5

NBC Defense FM21-40

Nuclear, Biological, and Chemical (NBC)
 Reconnaissance and Decontamination Operations FM 3-87

A-4. TECHNICAL MANUALS

Administrative Storage of Equipment TM 740-90-1

Operator's and Organizational Maintenance Manual for
 Battery Charger PP-7286/U TM 11-6130-392-12

Operator's and Organizational Maintenance Manual for
 Radio Set AN/GRC-106 TM 11-5820-520-12

Operator's and Organizational Maintenance Manual for
 Radio Set AN/GRC-160 TM 11-5820-498-12

Operator's and Organizational Maintenance Manual for
 Radio Set AN/PRC-77 TM 11-5820-667-12

Operator's and Organizational Maintenance Manual for
 Radio Set AN/VRC-12 TM 11-5820-401-12



A-4 . TECHNICAL MANUALS (CONT)

Operator's and Organizational Maintenance Manual
Including Repair Parts and Special Tools List for
Digital Message Device AN/PSG-2A TM 11-7440-281-12&P

Procedures For Destruction of Electronics Materiel
to Prevent Enemy Use (Electronics Command) TM 750-244-2

A-5. MISCELLANEOUS PUBLICATIONS

Army Materiel Maintenance Concepts and Policies AR 750-1

The Army Maintenance Management System (TAMMS) DA PAM 738-750

APPENDIX B

MAINTENANCE ALLOCATION CHART

SECTION I. INTRODUCTION

B-1 General

a. This section provides a general explanation of all maintenance and repair functions authorized at various maintenance categories.

b. The Maintenance Allocation Chart (MAC) in section II designates overall authority and responsibility for the performance of maintenance functions on the identified end item or component. The application of the maintenance functions to the end item or component will be consistent with capacities and capabilities of the designated maintenance categories.

c. Section III lists the tools and test equipment (both special tools and common tool sets) required for each maintenance function as referenced from section II.

d. Section IV contains supplemental instructions and explanatory notes for a particular maintenance function.

B-2 Maintenance functions. Maintenance functions will be limited to and defined as follows:

a. Inspect. To determine the serviceability of an item by comparing its physical, mechanical, and/or electrical characteristics with established standards through examination (e.g., by sight, sound, or feel).

b. Test. To verify serviceability by measuring the mechanical or electrical characteristics of an item and comparing those characteristics with prescribed standards.

c. Service. Operations required periodically to keep an item in proper operating condition, i.e., to clean, (includes decontaminate, when required), to preserve to paint.

d. Replace. To remove an unserviceable item and install a serviceable counterpart in its place. "Replace" is authorized by the MAC and is shown as the 3d position code of the SMR code.

INTRODUCTION (CONT)

e. Repair. The application of maintenance services (1), including fault location/troubleshooting (2), removal/installation, and disassembly/assembly (3), procedures, and maintenance actions (4), to identify troubles and restore serviceability to an item by correcting specific damage, fault, malfunction, or failure in a part, subassembly, module (component or assembly), end item, or system.

f. Overhaul. That maintenance effort (service/action) prescribed to restore an end item to a completely serviceable/operational condition as required by maintenance standards in appropriate technical publications (i.e., DMWR). Overhaul is normally the highest degree of maintenance performed by the Army. Overhaul does not normally return an item to like new condition.

B-3 Explanation of Columns in the MAC, Section II

a. Column 1, Group Number. Column 1 lists functional group code numbers, the purpose of which is to identify maintenance significant components, assemblies, sub-assemblies, and modules with the next higher assembly.

b. Column 2, Component/Assembly. Column 2 contains the names of components, assemblies, subassemblies, and modules for which maintenance is authorized.

c. Column 3, Maintenance Function. Column 3 lists the functions to be performed on the item listed in Column 2. (For detailed explanation of these functions, see paragraph B-2.)

(1) Services - inspect, test, service, adjust, aline, calibrate, and/or replace.

(2) Fault locate/troubleshoot - The process of investigating and detecting the cause of equipment malfunctioning; the act of isolating a fault within a system or unit under test (UUT).

(3) Disassemble/assemble - encompasses the step-by-step taking apart (or breakdown) of a spare/functional group coded item to the level of its least componency identified as maintenance significant (i.e., assigned an SMR code) for the category of maintenance under consideration.

(4) Actions - welding, grinding, riveting, straightening, facing, remachining, and/or resurfacing.

INTRODUCTION (CONT)

d. Column 4, Maintenance Category. Column 4 specifies, by the listing of a work time figure in the appropriate subcolumn(s), the category of maintenance authorized to perform the function listed in Column 3. This figure represents the active time required to perform the maintenance function at the indicated category of maintenance. If the number or complexity of the tasks within the listed maintenance function vary at different maintenance categories, appropriate work time figures will be shown for each category. The work time figure represents the average time required to restore an item (assembly, subassembly, component, module, end item, or system) to a serviceable condition under typical field operating conditions. This time includes preparation time (including any necessary disassembly/assembly time), troubleshooting/fault location time, and quality assurance/quality control time in addition to the time required to perform the specific tasks identified for the maintenance functions authorized in the maintenance allocation chart. The symbol designations for the various maintenance categories are as follows:

- C Operator Crew
- O Organizational Maintenance
- F Direct Support Maintenance
- H General Support Maintenance (Not applicable)
- D Depot Maintenance

e. Column 5, Tools and Equipment. Column 5 specifies, by code, those common tool sets (not individual tools) and special tools, TMDE, and support equipment required to perform the designated function.

f. Column 6, Remarks. This column shall, when applicable, contain a letter code, in alphabetic order, which shall be keyed to the remarks contained in Section IV.

B-4 Explanation of Columns in Tool and Test Equipment Requirements, Section III

- a. Column 1, Reference Code. The tool or test equipment reference code correlates with a code used in the MAC, Section II, Column 5.
- b. Column 2, Maintenance Category. The lowest category of maintenance authorized to use the tool or test equipment.
- c. Column 3, Nomenclature. Name or identification of the tool or test equipment.
- d. Column 4, National/NATO Stock Number. The National stock number of the tool or test equipment.
- e. Column 5, Tool Number. The manufacturer's part number.

B-5 Explanation of Columns in Remarks, Section IV

- a. Column 1, Reference Code. The code recorded in Column 6, Section II.
- b. Column 2 Remarks. This column lists information pertinent to the maintenance function being performed as indicated in the MAC, Section II.

SECTION II. MAINTENANCE ALLOCATION CHART FOR M23

(1) GROUP NUMBER	(2) COMPONENT/ASSEMBLY	(3) MAINTENANCE FUNCTION	(4) MAINTENANCE CATEGORY					(5) TOOLS AND EQPT.	(6) REMARKS	
			C	T	F	H	D			
00	Computer Set, Ballistics: Mortar M23	Inspect Test Service Repair Overhaul	.1 .1 .1	.1				20.2	1, 2, 3, 4, 5, 6, 8, 9, 10 11, 12, 13, 14	B A C
01	Computer, Ballistics: Mortar	Inspect Replace Repair	.1 .1	.1 .1	.1 .1			4		D, J
0101	Circuit Card Assembly: Display (Programed)	Replace Repair			.1			4.5	8, 9, 14 2, 3, 5, 8, 10	E
0102	Chassis Electrical	Replace Repair			.1 .1				8, 9 3, 8, 9	G
010201	Interface Assembly	Replace Repair			.2 .2				8, 9 3, 8, 9	G

MAINTENANCE ALLOCATION CHART (CONT)

(1) GROUP NUMBER	(2) COMPONENT/ASSEMBLY	(3) MAINTENANCE FUNCTION	(4) MAINTENANCE CATEGORY					(5) TOOLS AND EQPT.	(6) REMARKS
			C	O	F	H	D		
01020101	Power Supply Assembly	Replace Repair			.3 .6			8, 9 8	G
0102010101	Circuit Card Assembly (A6APS1A1)	Replace Repair			.8 .2			8, 9	H
0102010102	Circuit Card Assembly (A6A1PS1A2)	Replace Repair			.8 .8			8, 9	F
01020102	Audio Interface	Replace Repair			.4		1	8, 9 1, 3, 4, 5, 8, 13	E
01020103	Connector Assembly	Replace Repair			.2 .2			8, 9 8	I
0103	Circuit Card Assembly: Memory (Programmed)	Replace Repair			.1		1	8, 9 2 3 , 5 8, 11	E
0104	Case Computer	Replace Repair			.2 .9			8, 9 3, 8, 9	K

MAINTENANCE ALLOCATION CHART (CONT)

(1) GROUP NUMBER	(2) COMPONENT/ASSEMBLY	(3) MAINTENANCE FUNCTION	(4) MAINTENANCE CATEGORY					(5) TOOLS AND EQPT.	(6) REMARKS
			C	O	F	H	D		
010401	Circuit Card Assembly (A4A1)	Replace Repair			.5 .1			8, 9, 14 5	H
0105	Circuit Card Assembly: Modem	Replace Repair			.1		.5	8, 9 2, 3, 5, 6, 8, 12	
02	Cable Assembly, Special Purpose, Electrical (CX-13152/PSG-2A)	Inspect Test Replace Repair	.1		.1 .1 .3			3 7 8	
03	Cable Assembly, Special Purpose, Electrical (CX-13148/PSG2A)	Inspect Test Replace Repair	.1		.1 .2 .3			3 7 8	
04	Cable Assembly, Special Purpose, Electrical (CX-13150/GR)	Inspect Test Replace Repair	.1		.1 .2 .3			3 7 8	
05	Cable Assembly, Special Purpose Electrical (CX-13151/PSG-2)	Inspect Test Replace Repair	.1		.1 .1 .7			3 7 8	

SECTION III. TOOL AND TEST EQUIPMENT REQUIREMENTS

TOOL OR TEST EQUIPMENT REF CODE	MAINTENANCE CATEGORY	NOMENCLATURE	NATIONAL/ NATO STOCK NUMBER	TOOL NUMBER
1	D	Test Station, Electronics AN/USM-410V	6625-01-070-3658	
2	D	Test Set, Digital AN/USM-465A	6625-01-126-2473	
3	D, F	Multimeter, Digital AN/USM-486/U	6625-01-145-2430	
4	D, F	Power Supply PP-6801/U	6130-00-406-5695	
5	D, F	Repair Center PRC350C	3439-00-196-0703	
6	D	Tool Kit, Electronic Equipment TK-100/G	5180-00-605-0079	SC 5180-91- CL-S21
7	d	Tool Kit, Electronic Equipment TK-101/G	5180-00-064-5178	SC 5180-91- CL-R13
8	D, F	Tool Kit, Electronic Equipment TK-105/G	5180-00-610-8177	SC 5180-91 - CL-R07
9	D, F	Bit, Crosstip	5120-01-161-1729	9355698
10	D	Tst Pgm St Display/Processor		9355719
11	D	Tst Pgm St Memory		9355745
12	D	Tst Pgm St Modem		9355763
13	D	Tst Pgm St Audio		9355833
14	D, F	Screwdriver and Wrench 99-PS-50	5120-00-165-4098	

SECTION IV. REMARKS

REFERENCE CODE	REMARKS
A	Clean unit and replace battery.
B	Operational check
C	Repair limited to replacement of defective subassembly.
D	Repair by replacement of defective circuit card assembly or case.
E	Repair of assemblies by designated depot
F	Repair by replacement of keep alive battery
G	Repair by replacement of subassemblies.
H	Repair by replacement of fuse.
I	Repair by replacement of dustcovers.
J	Repair limited to battery replacement at operator and organizational level.
K	Repair by replacement of top cover, battery compartment cover, housing assembly, keyboard connector, or battery connector.

APPENDIX C

COMPONENTS OF END ITEM AND BASIC ISSUE ITEMS LISTS

SECTION I. INTRODUCTION

C-1. SCOPE

This appendix lists components of end item and basic issue items for the MBC to help you inventory items required for safe and efficient operation.

C-2. GENERAL

The Components of End Item and Basic Issue Items Lists are divided into the following sections:

a. Section II. Components of End Item. Not applicable.

b. Section III. Basic Issue Items. These are the minimum essential items required to place the MBC in operation, to operate it, and to perform emergency repairs. Although shipped separately packaged, BII must be with the MBC during operation and whenever it is transferred between property accounts. The illustrations will assist you with hard-to-identify items. This manual is your authority to request/requisition replacement BII, based on TOE/MTOE authorization of the end item.

C-3. EXPLANATION OF COLUMNS

The following provides an explanation of columns found in the tabular listings:

a. Column (1) - Illustration Number (Illus Number). This column indicates the number of the illustration in which the item is shown.

b. Column (2) - National Stock Number. Indicates the National stock number assigned to the item and will be used for requisitioning purposes.

c. Column (3) - Description. Indicates the Federal item name and, if required, a minimum description to identify and locate the item. The last line for each item indicates the FSCM (in parentheses) followed by the part number.

d. Column (4) - Unit of Measure (U/M). Indicates the measure used in performing the actual operational/maintenance function. This measure is expressed by a two-character alphabetical abbreviation (e.g., ea, in., pr).

e. Column (5) - Quantity required (Qty rqr). Indicates the quantity of the item authorized to be used with/on the equipment.

SECTION II. COMPONENTS OF END ITEM (Not Applicable)

SECTION III. BASIC ISSUE ITEMS

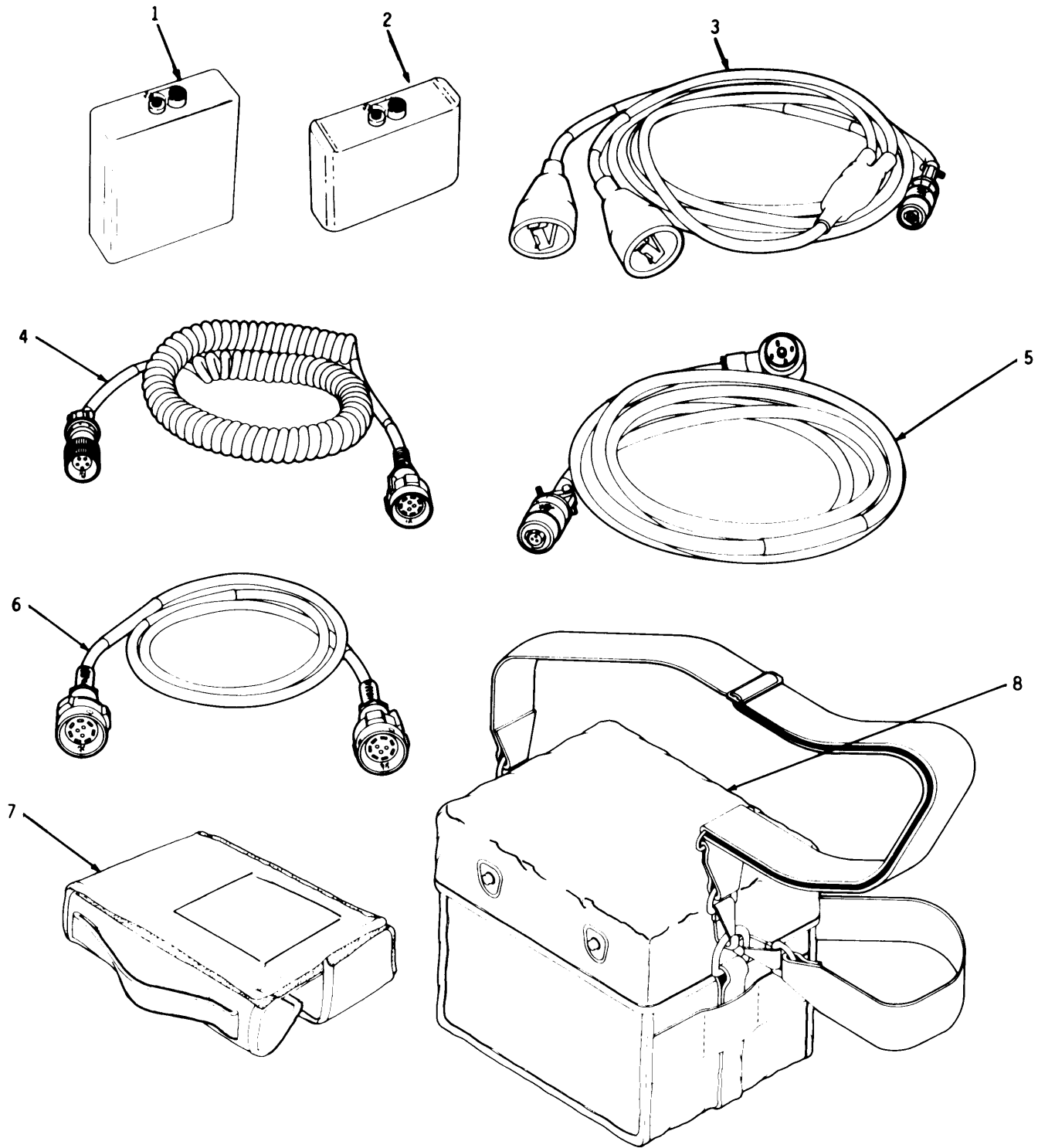

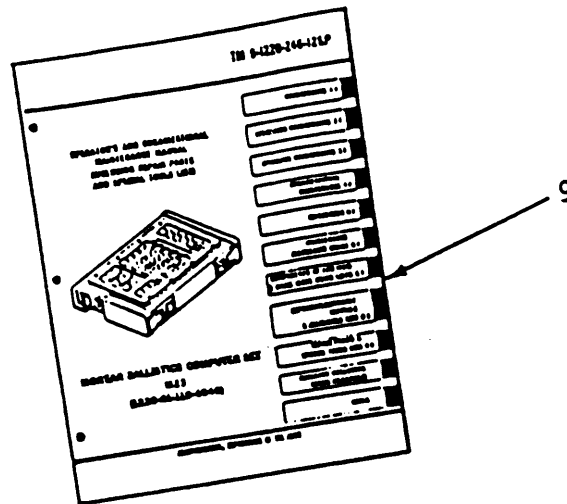

BASIC ISSUE ITEMS

(1) ILLUS NUMBER	(2) NATIONAL STOCK NUMBER	(3) DESCRIPTION FSCM AND PART NUMBER	USABLE ON CODE	(4) U/M	(5) QTY RQR
1	6135-01-088-2708	Battery, Dry (80058) BA-5588/U		EA	1
2	6135-01-094-6536	Battery, Nonrechargeable (80058) BA-1588/U		EA	1
3	5995-01-098-2613	Cable Assembly, Special purpose, Electrical (80063) SM-D-875489		EA	1
4	5995-01-104-0669	Cable Assembly, Special Purpose, Electrical (80063) SM-D-875498		EA	1
5	5995-01-098-7077	Cable Assembly, Special Purpose, Electrical (80063) SM-D-917637		EA	1
6	5995-01-098-7076	Cable Assembly, Special Purpose, Electrical (80063) SM-D-955457		EA	1
7	5840-01-188-7343	Case, Computer, Ballistics (19200) 9355747		EA	1
8	5895-00-889-3856	Case, Radio Set Container (80063) SM-C-456359		EA	1
9		TM 9-1220-246-12&P		EA	1

APPENDIX D

EXPENDABLE/DURABLE SUPPLIES AND MATERIALS LIST

Section I. INTRODUCTION

D-1. SCOPE

This listing is for informational purposes only and is not authority to requisition the listed items. These items are authorized to you by CTA 50-970, Expendable/Durable Items (Except Medical, Class V, Repair Parts, and Heraldic Items), or CTA 8-100, Army Medical Department Expendable/Durable Items.

D-2. EXPLANATION OF COLUMNS

a. Column (1) - Item Number. This number is assigned to the entry in the listing and is referenced to the narrative instructions to identify the material (e.g., "Use cleaning compound, item 5, App. D").

b. Column (2) - Level. This column identifies the lowest level of maintenance that requires the listed item.

C - Operator/Crew

c. Column (3) - National Stock Number. This is the National stock number assigned to the item; use it to request or requisition the item.

d. Column (4) - Description. Indicates the Federal item name and, if required, a description to identify the item. The last line for each item indicates the Federal Supply Code for Manufacturers (FSCM) in parentheses followed by the part number.

e. Column (5) - Unit of Measure (U/M). Indicates the measure used in performing the actual maintenance function. This measure is expressed by a two-character alphabetical abbreviation (e.g., ea, in, pr). If the unit of measure differs from the unit of issue, requisition the lowest unit of issue that will satisfy your requirements.

SECTION II. EXPENDABLE/DURABLE SUPPLIES AND MATERIALS LIST

(1)	(2)	(3)	(4)	(5)
ITEM NO.	LEVEL	NATIONAL STOCK NUMBER	DESCRIPTION	UNIT OF MEAS
1	C	6135-01-088-2708	BATTERY, STORAGE (80058) BA-5588/U	EA
2	C	8020-00-260-1305	BRUSH, VARNISH (81349) H-B-695	EA
3	C	8305-00-818-4567	CLOTH, CHEESECLOTH (81348) CCCC440	YD

SECTION II. REPAIR PARTS LIST

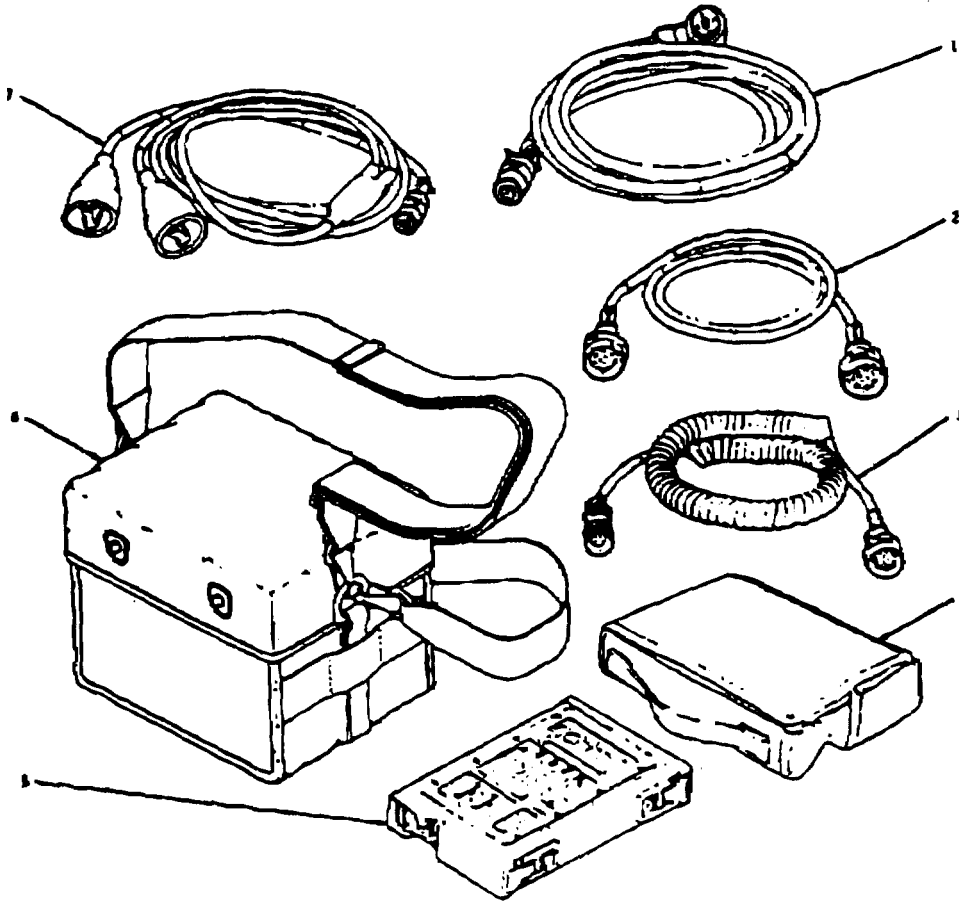

Figure E1. Computer set, ballistics: mortar M23 (11785850)

(1) ITEM NO	(2) SMR CODE	(3) FSCM	(4) PART NUMBER	(5) DESCRIPTION AND USABLE ON CODES (UOC)	(6) QTY
FIG. E1, GROUP 00: COMPUTER SET, BALLISTICS: MORTAR, M23 (11785850)					
1	PAOFF	80063	SM-0-917637	CABLE ASSEMBLY, SPECIAL PURPOSE, ELECTRICAL	1
2	PAOFF	80063	SM-D-955457	CABLE ASSEMBLY, SPECIAL PURPOSE, ELECTRICAL	1
3	PAOFF	80063	SM-D-875498	CABLE ASSEMBLY, SPECIAL PURPOSE, ELECTRICAL	1
4	PAOZZ	19200	9355747	CASE, COMPUTER, BALLISTICS	1
5	XADDD	19200	11785700-1	COMPUTER, BALLISTICS: MORTAR	1
6	PAOZZ	80058	SM-C-456359	CASE, RADIO SET CONTAINER	1
7	PAOFF	80063	SM-D-875489	CABLE ASSEMBLY, SPECIAL PURPOSE, ELECTRICAL	1

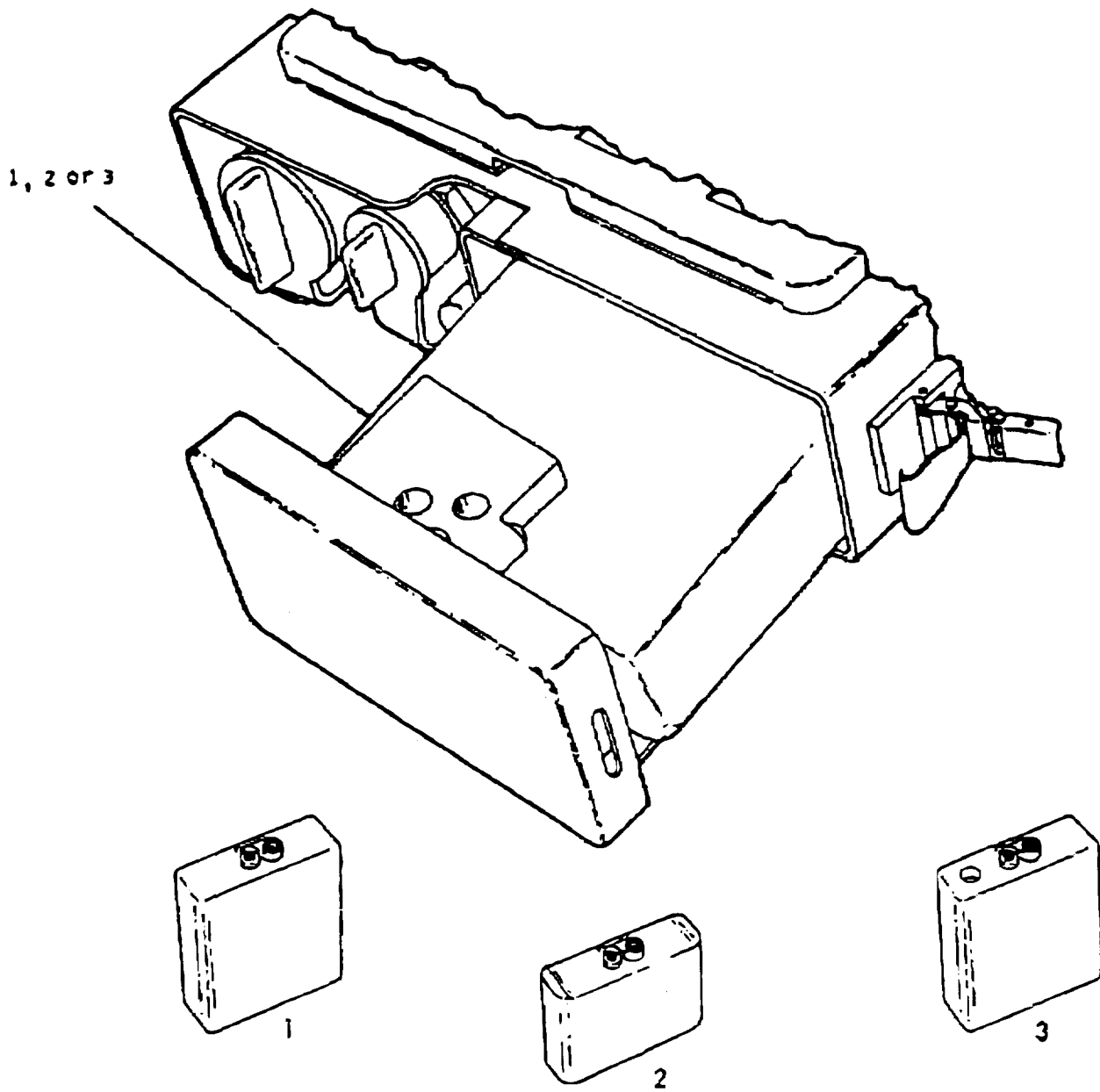

FIGURE E2. Computer, ballistics: mortar (1) (11785700 1)

(1) ITEM NO	(2) SMR CODE	(3) FSCM	(4) PART NUMBER	(5) DESCRIPTION AND USABLE ON CODES (UOC)	(6) QTY
-------------------	--------------------	-------------	-----------------------	--	------------

FIG. E2, GROUP 01: COMPUTER,
BALLISTICS: MORTAR (1) (11785700-1)

1	PCCZA	80058	BA-5588/U	BATTERY, DRY	1
2	PCCZA	80058	BA-1588/U	BATTERY, NONRECHARGABLE	1
3	PAOZA	80058	BA-588/U	BATTERY, STORAGE	1

END OF FIGURE

<u>Code</u>	<u>Explanation</u>
AO-(Assembled by Org Level)	} Items with these codes are not to be requested/requisitioned individually. The parts that make up the assembled item must be requisitioned or fabricated and assembled at the level of maintenance indicated by the source code. If the 3d position code of the SMR code authorizes you to replace the item, but the source code indicates the item is assembled at a higher level, order the item from the higher level of maintenance.
AF-(Assembled by DS Level)	
AH-(Assembled by GS Level)	
AD-(Assembled by Depot)	
XA-	Do not requisition an "XA"-coded item. Order its next higher assembly. (Also, refer to the NOTE below.)
XB-	If an "XB" item is not available from salvage, order it using the FSCM and part number given.
XC-	Installation drawing, diagram, instruction sheet, field service drawing, that is identified by manufacturer's part number.
XD-	Item is not stocked. Order an "XD"-coded item through normal supply channels using the FSCM and part number given, if no NSN is available.
NOTE:	Cannibalization or controlled exchange, when authorized, may be used as a source of supply for items with the above source codes, except for those source coded "XA" or those aircraft support items restricted by requirements of AR 700-42.

(2) Maintenance code. Maintenance codes tell you the level(s) of maintenance authorized to USE and REPAIR support items. The maintenance codes are entered in the third and fourth positions of the SMR Code as follows:

(a) The maintenance code entered in the third position tells you the lowest maintenance level authorized to remove, replace, and use an item. The maintenance code entered in the third position will indicate authorization to one of the following levels of maintenance.

<u>Code</u>	<u>Application/Explanation</u>
C	-Crew or operator maintenance done within organizational or aviation unit maintenance.
O	-Organizational or aviation unit level can remove, replace, and use the item.
F	-Direct support or aviation intermediate level can remove, replace, and use the item.

<u>Code</u>	<u>Application/Explanation</u>
H	-General support level can remove, replace, and use the item.
L	-Specialized repair activity can remove, replace, and use the item.
D	-Depot level can remove, replace, and use the item.

(b) The maintenance code entered in the fourth position tells you whether or not the item is to be repaired and identifies the lowest maintenance level with the capability to do complete repair (i.e., perform all authorized repair functions). (NOTE: Some limited repair may be done on the item at a lower level of maintenance, if authorized by the Maintenance Allocation Chart (MAC) and SMR codes.) This position will contain one of the following maintenance codes.

<u>Code</u>	<u>Application/Explanation</u>
0	-Organizational or aviation unit is the lowest level that can do complete repair of the item.
F	-Direct support or aviation intermediate is the lowest level that can do complete repair of the item.
H	-General support is the lowest level that can do complete repair of the item.
L	-Specialized repair activity is the lowest level that can do complete repair of the item.
D	-Depot is the lowest level that can do complete repair of the item.
Z	-Nonreparable. No repair is authorized.
B	-No repair is authorized. (No parts or special tools are authorized for the maintenance of a "B" coded item.) However, the item may be reconditioned by adjusting, lubricating, etc., at the user level.

(3) Recoverability code. Recoverability codes are assigned to items to indicate the disposition action on unserviceable items. The recoverability code is entered in the fifth position of the SMR Code as follows:

<u>Recoverability Codes</u>	<u>Application/Explanation</u>
Z	-Nonreparable item. When unserviceable, condemn and dispose of the item at the level of maintenance shown in 3d position of SMR code.
0	-Reparable item. When uneconomically reparable, condemn and dispose of the item at organizational or aviation unit level.
F	-Reparable item. When uneconomically reparable, condemn and dispose of the item at the direct support or aviation intermediate level.
H	-Reparable item. When uneconomically reparable, condemn and dispose of the item at the general support level.
D	-Reparable item. When beyond lower level repair capability, return to depot. Condemnation and disposal of item not authorized below depot level.
L	-Reparable item. Condemnation and disposal not authorized below specialized repair activity (SRA).
A	-Item requires special handling or condemnation procedures because of specific reasons (e.g., precious metal content, high dollar value, critical material, or hazardous material). Refer to appropriate manual/directives for specific instructions.

c. FSCM (Column(3)). The Federal Supply Code for Manufacturer (FSCM) is a 5-digit numeric code which is used to identify the manufacturer, distributor, or Government agency, etc., that supplies the item.

d. Part Number (Column(4)). Indicates the primary number used by the manufacturer (individual, company, firm, corporation, or Government activity), which controls the design and characteristics of the item by means of its engineering drawings, specifications standards, and inspection requirements to identify an item or range of items.

NOTE: When you use an NSN to requisition an item, the item you receive may have a different part number from the part ordered.

e. DESCRIPTION AND USABLE ON CODE (UOC) (Column (5)). This column includes the following information:

(1) The Federal item name and, when required, a minimum description to identify the item.

(2) The physical security classification of the item. Not applicable.

(3) Items that are included in kits and sets. Not applicable.

(4) Spare/repair parts that make up an assembled item are listed immediately following the assembled item line entry.

(5) Part numbers for bulk materials are referenced in this column in the line item entry for the item to be manufactured/fabricated.

(6) When the part is not used with all serial numbers of the same model. Not applicable.

(7) The Usable on Code, when applicable (see paragraph 5, Special Information).

(8) In the Special Tools List section, the basis of issue (BOI) appears as the last line(s) in the entry for each special tool, special TMDE, and other special support equipment. When density of equipments supported exceeds density spread indicated in the basis of issue, the total authorization is increased proportionately.

(9) The statement "END OF FIGURE" appears just below the last item description in Column 5 for a given figure in both Section II and III.

f. QTY (Column (6)). The QTY (quantity per figure column) indicates the quantity of the item used in the breakout shown on the illustration figure, which is prepared for a functional group, subfunctional group, or an assembly. A "V" appearing in this column in lieu of a quantity indicates that the quantity is variable and the quantity may vary from application to application.

4. Explanation of Columns (Sect. IV).

a. NATIONAL STOCK NUMBER (NSN) INDEX.

(1) STOCK NUMBER column. This column lists the NSN by National Item Identification Number (NIIN) sequence. The NIIN consists of the last nine digits of

the NSN (i.e., 5305-01-674-1467). When using this column to locate an item, ignore

the first 4 digits of the NSN. However, the complete NSN should be used when ordering items by stock number.

(2) FIG. column. This column lists the number of the figure where the item is identified/located. The figures are in numerical order in Section II and Section III.

(3) ITEM column. The item number identifies the item associated with the figure listed in the adjacent FIG. column. This item is also identified by the NSN listed on the same line.

b. PART NUMBER INDEX. Part numbers in this index are listed by part number in ascending alphanumeric sequence (i.e., vertical arrangement of letter and number combination which places the first letter or digit of each group in order A through Z, followed by the numbers 0 through 9 and each following letter or digit in like order).

(1) FSCM column. The Federal Supply Code for Manufacturer (FSCM) is a 5-digit numeric code used to identify the manufacturer, distributor, or Government agency, etc. , that supplies the item.

(2) PART NUMBER column. Indicates the primary number used by the manufacturer (individual, firm, corporation, or Government activity), which controls the design and characteristics of the item by means of its engineering drawings, specifications standards, and inspection requirements to identify an item or range of items.

(3) STOCK NUMBER column. This column lists the NSN for the associated part number and manufacturer identified in the PART NUMBER and FSCM columns to the left.

(4) FIG. column. This column lists the number of the figure where the item is identified/located in Section II and III.

(5) ITEM column. The item number is that number assigned to the item as it appears in the figure referenced in the adjacent figure number column.

5. Special Information. Use the following subparagraphs as applicable:

a. USABLE ON CODE. Not applicable.

b. FABRICATION INSTRUCTIONS. Not applicable.

c. ASSEMBLY INSTRUCTIONS. Not applicable.

d. KITS. Not applicable.

e. INDEX NUMBERS. Items which have the word BULK in the figure column will have an index number shown in the item number column. This index number is a cross-reference between the National Stock Number/Part Number Index and the bulk material list in Section II.

f. ASSOCIATED PUBLICATIONS. Not applicable.

g. ILLUSTRATIONS - LISTING. The illustrations in this RPSTL are identical to those published in TM 9-1220-246-34&P. Only those parts coded "C" or "O" in the third position of the SMR Code are listed in the tabular listing; therefore, there may be a break in the item number sequence. Only illustrations containing organizational or aviation unit authorized items appear in this RPSTL.

6. How to Locate Repair Parts.

a. When National Stock Number or Part Number is Not Known:

(1) First. Using the table of contents, determine the assembly group or subassembly group to which the item belongs. This is necessary since figures are prepared for assembly groups and subassembly groups, and listings are divided into the same groups.

(2) Second. Find the figure covering the assembly group or subassembly group to which the item belongs.

(3) Third. Identify the item on the figure and note the item number.

(4) Fourth. Refer to the Repair Parts List for the figure to find the part number for the item number noted on the figure.

(5) Fifth. Refer to the Part Number Index to find the NSN, if assigned.

b. When National Stock Number or Part Number is Known:

(1) First. Using the Index of National Stock Numbers and Part Numbers, find the pertinent National Stock Number or Part Number. The NSN index is in National Item Identification Number (NIIN) sequence (see 4.a(1)). The part numbers in the Part Number index are listed in ascending alphanumeric sequence (see 4.b). Both indexes cross-reference you to the illustration figure and item number of the item you are looking for.

(2) Second. After finding the figure and item number, verify that the item is the one you're looking for, then locate the item number in the repair parts list for the figure.

7. Abbreviations. Not applicable.

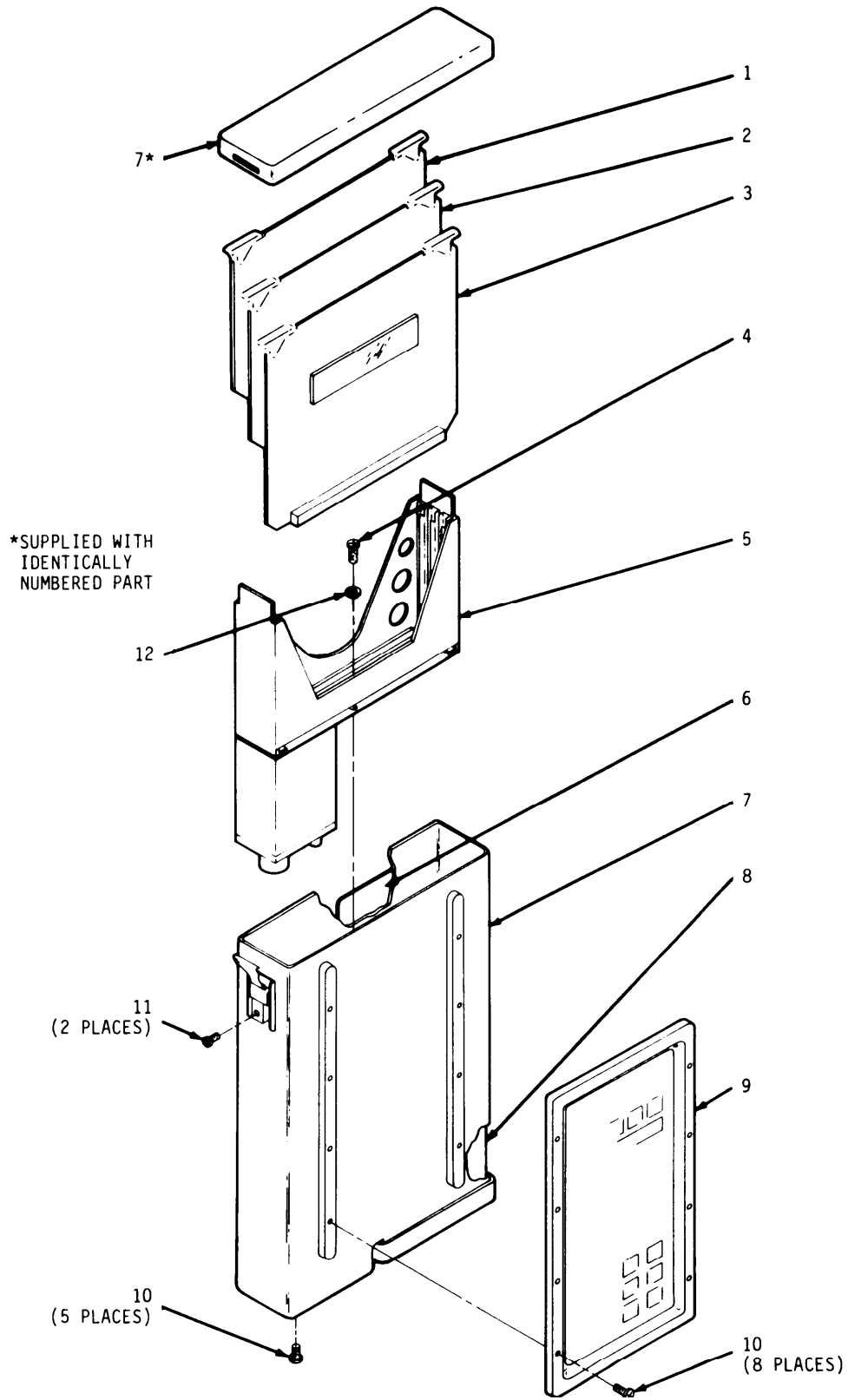

Figure E2. Computer, ballistics: mortar (1) (11785700-1)

SECTION II

TM9-1220-246-12&P

(1) ITEM NO	(2) SMR CODE	(3) FSCM	(4) PART NUMBER	(5) DESCRIPTION AND USABLE ON CODE (UOC)	(6) QTY
				FIG. E2, GROUP 01: COMPUTER, BALLISTICS: MORTOR (1) (11785700-1)	
8	PACZZ	80058	BA-5588/U	BATTERY, DRY	1
8	PACZZ	80058	BA-1588/U	BATTERY, NONRECHARGABLE	1
8	PAOZZ	80058	BB-588/U	BATTERY, STORAGE	1

END OF FIGURE

TM 9-1220-246-12&P

SECTION III. SPECIAL TOOLS LIST

NO SPECIAL TOOLS REQUIRED

SECTION IV

TM 9-1220-246-12&P

NATIONAL STOCK NUMBER AND PART NUMBER INDEX

NATIONAL STOCK NUMBER INDEX

STOCK NUMBER	FIG.	ITEM	STOCK NUMBER	FIG.	ITEM
5895-00-889-3856	E1	6			■
6135-01-088-2708	E2	1			
6140-01-091-1536	E2	3			
6135-01-094-6536	E2	2			
5995-01-098-2813	E1	7			
5995-01-098-7076	E1	2			
5995-01-098-7077	E1	1			
5995-01-104-0669	E1	3			
5840-01-188-7343	E1	4			■

NATIONAL STOCK NUMBER AND PART NUMBER INDEX

PART NUMBER INDEX

FSCM	PART NUMBER	STOCK NUMBER	FIG	ITEM
80058	BA-1588/U	6135-01-094-6536	E2	2
80058	BA-5588/U	6135-01-088-2708	E2	1
80058	BB-588/U	6140-01-091-1536	E2	3
80058	SM-C-456359	5820-00-889-3856	E1	6
80063	SM-D-875489	5995-01-098-2613	E1	7
80063	SM-D-875498	5995-01-104-0669	E1	3
80063	SM-D-917637	5995-01-098-7077	E1	1
80063	SM-D-955457	5995-01-098-7076	E1	2
19200	11785700-1		E1	5
19200	9355747	1220-01-188-7343	E1	4

GLOSSARY

SECTION I. ABBREVIATIONS

A list of abbreviations with their definitions.

<u>TERM</u>	<u>DEFINITION</u>
ABC	Atomic, Biological, Chemical
ACT	Aircraft
AD	Adjust
BAIT	Battery
BIT	Binary Digit
BIT	Built in Test
BAT	Brightness
CEIO	Communication, Electronic Operating Instructions
DIP	Display
ELM	End of Message
FOB	Forward Observer
FPF	Final Protective Fire
FISK	Frequency Shift Keyed
KEPT	Known Point
LED	Light Emitting Diode
LO	Location
MBC	Mortar Ballistics Computer
MET	Meteorological
MICA	Microprocessor
MOD	Modem
MSG	Message
MAN	Mission
MTOE	Modified Table of Organization and Equipment
NBC	Nuclear, Biological, Chemical
RAM	Random Access Memory
REG	Registration
ROM	Read Only Memory
SEQ	Sequence
SW	Switch
TIC	Technical Fire Control
TAT	Target
TIDE	Test Measurement Diagnostic Equipment
WPN	Weapon
EMIT	Transmit

SECTION II. DISPLAY ABBREVIATIONS AND WORDS

DISPLAY WORDS	ENTRY NAME AND UNITS	SELECTABLES, LEGAL ENTRIES	EXPLANATION
A	Section/unit name	1 to 6	Weapons are stored in the MBC by sections/units A, B, or C. Maximum of six weapons per unit.
ACK	Acknowledge	---	Automatic acknowledgement.
ADJ	Adjust fire command	---	Selection of adjustment menu.
ADJ: AUF/ SHEAF	Adjusting type	AUF, SHEAF	Select adjusting unit to fire-(AUF) or sheaf (SHEAF).
ADJ PT:	Adjust point	CENTER, FLANK	Selectable method of positioning SPECIAL sheaf.
ADJ WPN:	Adjusting weapon	1 to 6	Weapon to fire in adjustment phase.
AF	Adjust fire	---	Selectable method of fire use with control (CON).
ALARM	Al arm	ON/OFF	Audible alarm activated by a received message.
ALT:	Altitude/meters	-399 to 9999	Altitude of target (TGT), known point (KNPT), forward observer (FO), base piece (BP), or registration point (RP).
ANG T	Angle T/mils	---	Angle formed by gun target line and FO azimuth to target.
ASKNPT	Assign known point number	00 to 99	Request to assign a known point number to a target in file.
AT	Atmospheric pressure.	000 to 999	Atmospheric pressure at the MET station.
ATT	Attitude of target/mils	0000 to 6399	Azimuth of long side of rectangular target.
AZ	Azimuth/mils	0000 to 6399	Azimuth (measured from Grid North) on which fire unit is laid.
B	Section unit name	1 to 6	Same as A above.
BIT RATE	Bit rate	600 or 1200	Transmission rate of digital data, bits/second. Default = 1200.

DISPLAY ABBREVIATIONS AND WORDS (CONT)

DISPLAY WORDS	ENTRY NAME AND UNITS	SELECTABLES, LEGAL ENTRIES	EXPLANATION
BLK	Block rate	SNG, DBL	Transmission mode. Digital data messages are transmitted as single block, repeated and transmitted as a double block. Default (SNG).
BP	Base piece	A, B, and C/1 to 6.	Base piece identification.
BP	Burst point	---	Illumination round burst point.
BRT	Brightness	LOW, MED, HI, MAX	Selection of display brightness. Default (HI).
BURST-LASER	Laser data input	---	Menu enables operator to manually enter data received from laser-equipped FO.
C	Section name	1 to 6	Same as A above.
CARRIER	Vehicular carrier weapon.	YES, NO	Is weapon carrier mounted?
CAS	Number of casualties	0 to 999	DMD message input. Information only.
CENTER	Center	---	SPECIAL sheaf is centered on entered coordinates.
CHG:	Charge number	1 to 9	Charge to be used in fire mission. Applies only to 60mm and 81mm mortars.
CKFR	Check fire	---	Selectable status of round used with firing information (FI INFO).
CLR	Clear	---	Display switch. Clears specified entry from the MBC files.
CLR FILE	Clear file	---	Display switch, clears all data in specified file.
CMD	Command number of rounds	1RD, 2RD, 3RD RARP, RARP TI, REG NXLOT	Command number of rounds to be fired in precision registration.
CODE	Communications security code	----	See Communications Electronics Signal Instructions (CESI).

DISPLAY ABBREVIATIONS AND WORDS (CONT)

DISPLAY WORDS	ENTRY NAME AND UNITS	SELECTABLES, LEGAL ENTRIES	EXPLANATION
COMPUTING REG	Computing registration data	---	Occurs when UPDATE MET * is selected after registration using REG switch.
CON:	Control	AF = Adjust fire FFE = Fire for effect DST = Destruction REG = Registration WR AF = When ready adjust fire CNO AF = Cannot observe adjust fire AMC AF = At my command adjust fire WR FFE = When ready fire for effect AMC FFE = At my command fire for effect CNO FFE = Cannot observe fire for effect WR RFFE = When ready repeat fire for effect AMC RFFE = At my command repeat fire for effect CNO RFFE = Cannot observe repeat fire for effect	Selectable methods of fire control in TFC switch. Selectable methods of control in XMIT switch (MTO) selection.

DISPLAY ABBREVIATIONS AND WORDS (CONT)

DISPLAY WORDS	ENTRY NAME AND UNITS	SELECTABLES, LEGAL ENTRIES	EXPLANATION
CONT	Continue	---	Display switch. Used in traverse menu when intermediate point not stored. Also used in adjustment of MPI for additional rounds. Used to enter additional weapons to base piece. Used to enter safety diagrams.
CR	Correction factor	W = weight	Displayed when ammunition is weight corrected.
CS	Tactical	M630	Selectable shell type for 107mm. ■
CVG	Converged sheaf	---	Selectable type sheaf used with SHEAF.
△	Change factors	YES, NO	Operator decision. Do correction factors for ammunition need to be applied?
D:	Day	01 to 31	Day of month MET message becomes valid.
D:	Wind direction/ hundreds of roils	00 to 63	Ballistic wind direction in hundreds of roils; e.g., 290 = 2900 roils. Preceded by line number.
D	Down	---	Selectable entry for vertical angle (VANG) and height (HGT).
DBL	Double block	---	Selectable entry for BLK.
DEF:	Deflection/mils	0 to 6399	Horizontal clockwise angle measured from the azimuth of fire to the aiming point.
DEFK:	Deflection correction factor/ mils	L = left R = right 0 to 999	Correction factor applied to deflection for large lateral shifts in firing.
DESIG	Designate fire	---	Selectable status of round used with FI INFO.
DEV:	Deviation/meters	L = left R = right 0 to 999	Designating direction and distance from reference KNPT when using shift from KNPT to locate a new target.

DISPLAY ABBREVIATIONS AND WORDS (CONT)

DISPLAY WORDS	ENTRY NAME AND UNITS	SELECTABLES, LEGAL ENTRIES	EXPLANATION
DIGITAL	Digital transmitter	---	Used in XMIT switch to digitally send SHOT/SPLASH message
DIR:	Direction/mils	0 to 6399	In survey, azimuth from point-to-point. In requests for fire, azimuth from FO to target. In wpn data, direction of guns from base piece.
DIS:	Distance/meters	H = horizontal S = slant 0 to 9999	In survey, distance between points. H and S selectable used only in survey. In wpn data, distance of guns from base piece.
DIS:	Distance/meters	0 to 9999	In fire request, distance from FO to target when usig polar plot to locate a new target.
DISPO	Disposition of target	NEUT= neutralized BURN= burning NEUT-BURN= neutralized/ burning DEST=destroyed CNO= cannot observe UNK= unknown NONE= none NOTGVN= notgiven	DMO message input. Information only.
DOP	Degree of protection	---	Protection available to enemy personnel at target location. DMD input message.
			For first volley For subsequent volleys
		PRANO	Half prone All prone Half standing
		PRONE	Prone Prone
		PRUG	Prone Dug in
		PROVER	Prone Under overhead cover

DISPLAY ABBREVIATIONS AND WORDS (CONT)

DISPLAY WORDS	ENTRY NAME AND UNITS	SELECTABLES, LEGAL ENTRIES	EXPLANATION
		DUGIN	Dug in Dug in
		COVER	Under over Under overhead lead cover cover
		NOTGVN	Not given Not given
DSP	DISPLAY	---	Display switch. Activates test of all characters, dot segments, and LED indicators.
E:	Easting/meters	00000 to 99999	Coordinates.
ELEV:	Elevation/mils	800, 900, 1065	Elevation for 107 MM Mortars. Default (800).
EL:	Elevation/mils	+ 0000 to 1600	Output firing data.
ENT	Enter	---	Selectable for first entry of adjustment data in ADJ switch using (ADJ).
EOM	End of mission	---	Fire mission complete. Target data not recorded.
EOMRAT	End of mission record as target	---	Fire mission complete. Target number and location are stored in file for future reference.
EOMFPF	End of mission save as final protective fire	---	Fire mission complete. Save as final protective fire. Use FPF switch to recall data.
FFE	Fire for effect	---	Selectable method of fire used with CON.
FI INFO	Firing information	SHOT= Rounds fired. SPLASH= Warning (round will impact in approximately 5 seconds) DESIG = Designate target CKFR= Check fire	Status of round in command (CMD) message to observer. Default = SHOT

DISPLAY ABBREVIATIONS AND WORDS (CONT)

DISPLAY WORDS	ENTRY NAME AND UNITS	SELECTABLES, LEGAL ENTRIES	EXPLANATION
		CKFR ALL = Check fire all units. FIRE = Fire READY = Ready to fire DENY = Denied mission RND COMP = Round complete CAN CKE = Cancel check fire	
FILE	File	---	Display switches in ADJ switch (MPI) selection. Select FILE to store data for sighting.
FL TRACE	Front line trace	---	DMD input message. Location of forward elements of friendly forces.
FLANK	Flank	---	SPECIAL sheaf positioned with entered coordinates as left or right limit.
F0	Forward observer	0 to 9 and A to Z	F0 identification number. File must not exceed 12 F0's.
F0 MSN	Forward observer's: fire mission number	0 to 9	Number assigned to fire mission by F0.
FP	Failed illumination round impact point	---	Position that illumination round will impact if it does not burst.
FPF	Final protective fires	---	Final protective fires. Pre-established fire requests, with specific weapons assigned for quick response.
FR	Fire request	---	Appears in menu titles.
FS:	Fuze setting	00.0 to 99.9	Output in firing data.
FROM	Shift from KNPT or TGT	KNPT number TGT number	KNPT or TGT used by F0 as reference point to locate a new target.

DISPLAY ABBREVIATIONS AND WORDS (CONT)

DISPLAY WORDS	ENTRY NAME AND UNITS	SELECTABLES, LEGAL ENTRIES	EXPLANATION
G:0	Valid period/hours	0 to 9	Valid period of MET message. 1 to 8 used for first 8 hours, 9 = 12 hours (9 not used by United States units.) Always 0 in MBC MET message.
GD	Grid declination/mils	0 to 99	Grid declination in tens of roils; e.g., 20 = 200 mils.
GRID	Grid	---	Method of locating targets using grid coordinates.
GT	Gun target line	---	Line from guns to targets.
GUNS:XXXXXX	Guns	1 to 6	Weapons to fire mission during fire for effect. Output from TFC switch when FFE or OST selected.
GZ	Grid zone	STD=standard	Grid zone of user location.
H	Horizontal distance	---	Selectable used with DIS in survey. Indicates type of measurement between points.
HIDC	High angle danger close	---	Information from DMD - supported mission.
HE	High explosive	M49A4 M720 M888 60MM	Ammunition type
		M374, M889A1 M374A2 M821A1 M374A3, M821 M889 81MM	
		M329A1 M329A2 107MM	
		M933, M934 M57 120MM	
HGT:MTR	Height/meters	---	Adjustment to burst height in meters.
HGT:FT	Height/feet	---	Adjustment to burst height in feet.
HT:	Height entry	U = U p D = down 0 to 999	Height entry for burst adjustment.

DISPLAY ABBREVIATIONS AND WORDS (CONT)

DISPLAY WORDS	ENTRY NAME AND UNITS	SELECTABLES, LEGAL ENTRIES	EXPLANATION
HI	High	---	Selectable light intensity for display used with BRT.
ILL	Illumination	M83A3 M721 60MM	Shell type when used in initializatfon. (Also a selectable used with SH/FZ in technical fire control (TFC).
		M301A3 M853A1 81MM	
		M335A2 107MM	
		M930 M91 120MM	
INIT	Initialization		Display switch. Used for first input of FPF data, and adjustment data.
INSTR	Instructions	---	Display switch used for Self-Test of firmware instruction.
INT	Intersection	---	Selectable survey function.
IP	Intermediate point	---	Locations between start point and final destination of traverse scheme at which angular and distance measurements are entered for computation.
KEY TONE	Key tone/seconds	0.2, 0.7, 1.4, 2.1, 2.8, 3.5, 4.2, 4.8	Length of time communications device (radio) requires to enable transmitter prior to sending data. Default = 1.4
KNPT	Known point	0 to 99 (only 50 stored)	Usually a previously fired target or registration point. Location must be known to both FO and fire detection center (FUC) personnel. Also selectedable in FPF and survey.
KP:	Known point	Same as KNPT	Same as KNPT
L	Left	---	Selectable entry for DEV. Selectable entry for SPECIAL Sheaf.
LA:	Latitude/degrees	00.0 to 90.0	Latitude of MET station in tens, units and tenths of degrees.
USER	Laser	---	Method of target location, using laser equipment.

DISPLAY ABBREVIATIONS AND WORDS (CONT)

DISPLAY WORDS	ENTRY NAME AND UNITS	SELECTABLES, LEGAL ENTRIES	EXPLANATION
LGTH:	Length/meters	0 to 9999	Length of rectangular target.
LINE:	Line	1, 2, or 3	Line of weapons to fire FPF.
LLAZ:	Left limit azimuth/mils	0 to 6399	Left limit of safety area.
LN	No fire line	---	Location of no fire line.
LO:	Longitude/degrees	00.0 to 99.0	Longitude of MET station in tens, units and tenths of degrees.
MAIN	Main target type	---	Target type and subtype received in DMD fire requests.
MANUAL	Manual transmission	---	Used in XMIT switch when sending SHOT SPLASH by voice.
MAX	Maximum	---	Selectable light intensity for display used with BRT.
MAX ORD:	Maximum ordinate/meters	0 to 9999	Predicted maximum ordinate of projectile. Output in SFTY DATA switch.
MAX RN:	Maximum range/meters	1 to 8191	Maximum range boundary of safety area.
MED	Medium	---	Selectable light intensity for display use with BRT.
MET	Meteorology	---	Meteorological data effects on ballistics.
METCM	Current MET message	---	MET data stored in MEC and in use.
MICR	Microprocessor	---	Display switch, activates Self-Test of random access memory (RAM), read only memory (ROM), and firmware instructions.
MIN E: 0000	Minimum Easting	0 to 999000	Easting coordinate at lower left-hand corner of area of operations.
MIN N: 0000	Minimum Northing	0 to 999000	Northing coordinate at lower left-hand corner of area of operations.
MIN RN:	Minimum range/meters	1 to 8191	Minimum range boundary of safety area.

DISPLAY ABBREVIATIONS AND WORDS (CONT)

DISPLAY WORDS	ENTRY NAME AND UNITS	SELECTABLES, LEGAL ENTRIES	EXPLANATION
MOD	MODEM (modulator, demodulator)	---	Display switch, activates Self-Test of MODEM. The MODEM is that part of computer used to receive and transmit digital data.
MOE	Method of engagement	HI DC = High angle danger close LO DC = Low angle danger close DST DC = Obstruction danger close HI REG = High angle registration LO REG = Low angle registration DST REG = Obstruction registration HI TOT = High angle time on target LO TOT = Low angle time on target DST TOT = Destruction time on target DENY = Denied mission	Selectable methods of engagement in XMIT switch (MTO) selection.
MPI	Mean point of Impact	---	Display switch. Activates menu for mean point of impact registration.
MSN	Mission	1, 2, or 3	Appears in mission switch menu indicating which of three (1, 2, or 3) active missions is being displayed. Also appears in Fire request menus.

DISPLAY ABBREVIATIONS AND WORDS (CONT)

DISPLAY WORDS	ENTRY NAME AND UNITS	SELECTABLES, LEGAL ENTRIES	EXPLANATION
MTO	Message to observer	---	Output message to FO showing status of mission.
N	Northing/meters	00000 to 99999	Coordinates.
NAK	Non-acknowledge	---	MTO or CMD message not acknowledged by DMD (message not authenticated).
NEW	New MET message	---	MET data stored in MBC, but not in use.
NFI	No fire zone	---	No fire zone, used with zone (ZN)
NO RSP	No response	---	No response from MBC after transmission by CMD.
NORMAL	Normal	---	Selectable polar plot data input used in POLAR switch menu.
NR UNITS:	Number of units	0 to 18	Number of weapons to fire in effect.
NR VOL:	Number of volleys	0 to 99	Number of volleys to be fired in effect.
NXT	Next	---	Display switch used when reviewing FO, KNPT, and TGT files.
OBS LOC	Observer location	---	Menu used to enter FO locations in FO file.
OBSN	Observations	---	Adjustments of target data. Used only in laser type-missions.
			OKTGT = Update target location only; no fire commands
			OKBT = Produce shift to target location and output final commands
			DNOTGT = Update target location and output fire commands
			LOSTGT = Update target location and output fire commands
			IGNRD = Fire commands output based on previous location
			LOSTBT = Produce shift to target location and output fire commands

DISPLAY ABBREVIATIONS AND WORDS (CONT)

DISPLAY WORDS	ENTRY NAME AND UNITS	SELECTABLES, LEGAL ENTRIES	EXPLANATION
OBSN	Observations	---	Adjustments of target data. Used for mean point of impact missions.
		OK = Round ok.	
		DNO = Did not observe round.	
		LOST = Looking, but did not observe round.	
		IGN RD = Ignore round.	
OFF	Off	---	Selectable used with ALARM and MODEM.
ON	On	---	Selectable used with ALARM and MODEM.
OWN ID	Identification	0 to 9 and A to Z	MBC address.
P:	Air pressure/ millibars	0 to 1100	Air pressure.
POLAR	Polar plot	---	Method of target location using direction and distance from FO.
PREC ADJ	Precision adjustment	---	Precision adjustment menu initiated by DMD.
PR ERR	Probable error	0 to 99	Output in message to observer.
PRFX	Prefix	AA to ZZ	Target number prefix.
PRL	Parallel	---	Selectable used with SHEAF.
PTS	Points	0 to 80	Number of points used in establishing a zone. Not less than 3 points/zone.
Q	Octant	0 to 9	Octant of earth in which MET station located.
Q	Quick	---	Type of fuze.
QF KNPT	Quick fire known point	---	Quick fire, type fire mission on a recorded KNPT.
QF TGT	Quick fire target	---	Quick fire, type fire mission on a recorded target.

DISPLAY ABBREVIATIONS AND WORDS (CONT)

DISPLAY WORDS	ENTRY NAME AND UNITS	SELECTABLES, LEGAL ENTRIES	EXPLANATION
R	Right		Selectable entry for DEV.
R	Right	---	Selectable entry for SPECIAL Sheaf.
RAD	Radius/meter	---	Radius of circular target. DMD message input.
RAM	Random access memory	---	Component of computer. Abbreviation appears in display only if RAM fails self-test (MICR).
RCF	Range correction factor	0 to 9999	Correction factor computed from registration.
RDR REG	Radar registration	---	DMD input of data from a radar registration.
READY	Ready	---	When READY appears on display, indication is menu flow associated with last switch action is complete. Make next selection.
READY	Ready	---	Selectable firing information in CMD message to observer.
REF DIR:	Reference direction/mils	0 to 6399	In MPI registration, direction from FO to intended impact point.
REF VA:	Reference vertical angle/roils	-999 to 1600	In MPI registration, vertical angle from FO to intended impact point.
REG	Registration	---	Registration menu. Enables operator to input target data and compute RCF and DEF K.
REG/MET	Registration/MET	YES, NO	Availability of registration and MET data for specified target.
RES	Resection	---	Survey function.
RETRY #	Retry	# i s 1 , 2 , o r 3	Display switch used with NO RSP RETRY.
REV	Review	---	Selectable in ADJ switch. Used to review data.
RLAZ :	Right limit azimuth/mils	0 to 6399	Right limit of safety area.

DISPLAY ABBREVIATIONS AND WORDS (CONT)

DISPLAY WORDS	ENTRY NAME AND UNITS	SELECTABLE, LEGAL ENTRIES	EXPLANATION
RN:	Range	+ 0 r - 0 to 9999	In fire request (SHIFT), deviation from reference point. In adjustment, change in range required to bring fire on the target.
ROM	Read only memory	---	Component of computer. Abbreviation appears in display only if ROM or EPROM fails self-test (MICR) .
RP	Registration point	0 to 16	A clearly defined permanent or semi-permanent object or feature located close to the center of the fire area or zone of action.
RP	Red Phosphorous	M819	Ammunition Type.
S	Slant distance	---	Selectable used with DIS in survey.
SA	Station altitude/ tens of meters	0 to 99	Altitude of MET station in tens of meters; e.g., 33 = 330 meters.
SA LASER	Subsequent adjust- ment laser	---	DMD input message containing LASER type data for subsequent adjustment.
SAVED	Target number saved	---	Output indicating specified target has been stored in the TGT file.
SHEAF	Sheaf	PRL = parallel CVG = converged SPECIAL = special	Lateral distribution of two or more pieces fired together. Default = PRL.
SH/FZ	Shell/Fuze	HE PD, WP PD, ILL MT, CS MT, HE PITA, HE MTB, HE VT, RP,TRN	Shell fuze combination to be used in fire mission. Default = HE PD.
SHIFT	Shift	---	Method of target location using reference point.
SHOT	Shot	---	Selectable status of round used with FI INFO.
SIGHT:	Sighting line #	1 to 9	Sequence number assigned to sighting for MPI mission.

DISPLAY ABBREVIATIONS AND WORDS (CONT)

DISPLAY WORDS	ENTRY NAME AND UNITS	SELECTABLE, LEGAL ENTRIES	EXPLANATION
SPECIAL	Special sheaf	---	Selectable used with SHEAF.
SPLASH	Splash	---	Selectable status of round used with FI INFO.
STORE	Store	---	Display switch to store data in files.
ST:	Store	---	Display switch to store data in files.
STR	Strength	0 to 999	Number of specified target types.
SUB	Target subtype	See Glossary, Section 111	Description of MAIN type target being attacked; e.g., MAIN type = bridge, subtype = pontoon.
SURVEYED TGT	Surveyed target	No/Yes	No = Store adjusted target location. Yes = Store initial target location used to start mission.
SW	Switch	---	Display switch activates test of all switches on control panel.
T:	Time/tenths of hours	0 to 23.9.	Time MET message becomes valid. In tenths of hours; e.g., 23.5 = 2330 hrs.
T:	Ballistic air temperature/percent of of standard	0 to 500.0	Ballistic air temperature. Preceded by line number.
TEMP :	Powder temperature degrees	+ or - 0 to 130	Powder temperature for all ammunition lots. Default = 70.
TEXT	Free text message	---	Free text message from DMD.
TFC	Technical fire control	---	Selection of weapons, type and number, sheaf shell fuze combination, control and use of registration data.
TGT PRFX	Target number prefix	AA to ZZ	Alphabetic prefix to target number.
TGT :	Target number	0000 to 9998	Target number.

DISPLAY ABBREVIATIONS AND WORDS (CONT)

DISPLAY WORDS	ENTRY NAME AND UNITS	SELECTABLES, LEGAL ENTRIES	EXPLANATION
TIME OUT	Time out/seconds	15, 30, 45, 60	Length of time display will remain active in the absence of switch action.
TIMING	Timing	---	Time between SHOT and SPLASH message.
TN:	Target number block	0000 to 9994	Block of numbers to be used by computer. First entry is first number to be used, second entry is last number to be used. See your unit operational instructions.
TOF:	Time of flight/seconds	00.0 to 99.9	Projectile time of flight output in FIRE DATA switch.
■ TRN	Training round	M68, M880 M1,M879 81MM	Selectable shell used with SH/FZ
TYPE	Target type	See Glossary, Section III.	MAIN type target being attacked.
U	up	---	Selectable vertical direction used with VANG or HGT.
V	Wind velocity/knots	0 to 300	MET message wind speed.
V ANG:	Vertical angle/mils	0 to 1250 U = up D = down	Angle formed by difference in altitude between FO and target in laser type mission.
VA FO:	Vertical angle Forward observer	---	In MPI mission, the FO reporting vertical angle to burst.
VT	Variable time fuze	---	Selectable fuze type used with SH/FZ.
W	Delta weight	0 t o 9	Enter number of squares on pro-tile. Enter only nonstandard weights.
WD	Width/meters	0 to 9999	Width of rectangular target.
WID	Width/meters	0 to 999	Width of SPECIAL sheaf.

DISPLAY ABBREVIATIONS AND WORDS (CONT)

DISPLAY WORDS	ENTRY NAME AND UNITS	SELECTABLES, LEGAL ENTRIES	EXPLANATION
WP	White phosphorous	M302A2 M302A1 M722 60MM	Selectable shell type. Used with SH/FZ weapon.
		M375 M375A3 M375A2 81MM	
		M328A1 107MM	
		M68 M929 120MM	
WP	Weapon	---	Weapon.
		---	Menu used by operator to select shell fuze type for fire mission.
WR	When ready	---	Adjust fire when ready. DMD message input.
XMIT	Transmit	---	Display switch used to transmit CMD and MT0.
XMITTING	Transmitting	---	Message is being transmitted to F0. Appears in display momentarily.
ZN	No fire zones	0 to 9	No Fire Zones; established with minimum of three points, 80 points available, but not more than 10 zones may be entered,
+	Plus/add	---	Direction of change in range when shifting from reference point or adjusting fire.
-	Minus/drop	---	Direction of change in range when shifting from reference point or adjusting fire.

SECTION III. TARGET TYPE AND SUBTYPE MNEMONICS

MAIN TYPE		SUBTYPE	
MNEMONIC	DEFINITION	MNEMONIC	DEFINITION
ADA	Air defense artillery	UNK	Unknown
		LT	Light
		MOM	Medium
		HV	Heavy
		MSL	Missile
		POS	Position
ARMOR	Armor	UNK	Unknown
		LT	Light
		MOM	Medium
		HV	Heavy
		APC	Armored personnel carrier
		POS	Position
ARTY	Artillery	UNK	Unknown
		LT	Light
		MOM	Medium
		HV	Heavy
		POS	Position

TARGET TYPE AND SUBTYPE MNEMONICS (CONT)

MAIN TYPE		SUBTYPE	
MNEMONIC	DEFINITION	MNEMONIC	DEFINITION
ASY	Assembly areas	UNK	Unknown
		TRP	Troops
		TRPVEH	Troops and vehicles
		TRPMEC	Mechanized troops
		TRPARM	Troops and armor
BLDG	Building	UNK	Unknown
		WOOD	Wood
		MASNRY	Masonry
		CONC	Concrete
		MET	Metal
		SPCL	Special purpose
BRIDG	Bridge	UNK	Unknown
		FTPON	Foot pontoon
		VEPON	Vehicle pontoon
		CONC	Concrete
		WOOD	Wood
		STEEL	Steel
		SITE	Site
		RAFT	Raft
		FERRY	Ferry

TARGET TYPE AND SUBTYPE MNEMONICS (CONT)

MAIN TYPE		SUBTYPE	
MNEMONIC	DEFINITION	MNEMONIC	DEFINITION
CEN	Center	UNK	Unknown
		SMALL	Small
		BN	Battalion
		REGT	Regiment
		DIV	Division
		FWD	Forward
EQUIP	Equipment	UNK	Unknown
		RADAR	Radar
		EW	Electronic warfare
		SLT	Searchlight
		GDNC	Guidance
		LS	Loudspeaker
MORT	Mortars	UNK	Unknown
		LT	Light
		MDM	Medium
		HV	Heavy
		VH	Very heavy
		POS	Position

TARGET TYPE AND SUBTYPE MNEMONICS (CONT)

MAIN TYPE		SUBTYPE			
MNEMONIC	DEFINITION	MNEMONIC	DEFINITION		
PERS	Personnel	UNK	Unknown		
		INF	Infantry		
		OP	Observation post		
		PTL	Patrol		
		WKPTY	Work party		
		POS	Position		
		RKMSL	Rockets/ missiles	UNK	Unknown
APERS	Antipersonnel				
LT	Light missile				
MDM	Medium missile				
HV	Heavy missile				
ATANK	Antitank				
POS	Position				
SPEC	Special			ONCALL	Not used
				ILL1	Illumination - 1 gun
		ILL2	Illumination - 2 guns		

TARGET TYPE AND SUBTYPE MNEMONICS (CONT)

MAIN TYPE		SUBTYPE	
MNEMONIC	DEFINITION	MNEMONIC	DEFINITION
SUPPLY	Supply dump	ILL2DF	Illumination - 2 guns with spread in deflection
		ILL2GS	Illumination - 2 guns with spread in range
		ILL4	Illumination - 4 guns
		GASNON	Nonpersistent gas
		GASPER	Persistent gas
		LEAF	Leaflets
		UNK	Unknown
		AMMO	Ammunition
		PTL	Petroleum, oil
		BRGEQ	Bridging equipment
TER	Terrain features	CLI	Class 1
		CLII	Class 2
		UNK	Unknown
		ROAD	Road
		JCT	Road junction

TARGET TYPE AND SUBTYPE MNEMONICS (CONT)

MAIN TYPE		SUBTYPE	
MNEMONIC	DEFINITION	MNEMONIC	DEFINITION
VEH	Vehicle	HILL	Hill
		DEFILE	Defile
		LDGSTR	Landing strip
		RR	Railroad
		UNK	Unknown
		LT	Light wheeled
		HV	Heavy wheeled
		RECON	Reconnaissance
		BT	Boats
		ACFT	Aircraft
WPN	Weapons	HELO	Helicopter
		UNK	Unknown
		LTMG	Light machine gun
		ATG	Antitank gun
		HVMG	Heavy machine gun
		RCLR	Recoilless rifle
POS	Position		

SECTION IV. ERROR MESSAGES

DISPLAY INDICATIONS

@ = Alpha character
 # = Numeric character
 \$ = Alpha or numeric character

ERROR MESSAGE	EXPLANATION/ACTION
@# * RANGE ERR *	<p>Target location cannot be precisely achieved by ballistics calculations. Following menu indicates error magnitude.</p> <p>ACTION : Verify all initialization and input data. Check error magnitude in following menu. If error is excessive use alternate weapon or ammunition type.</p>
@# ACTIVE,MSN #	<p>Weapon selected (@#) is currently activated for mission #.</p> <p>ACTION: Choose alternate weapon not currently in use, or terminate mission #.</p>
@# IS BP	<p>When entering WPN DATA, base piece number entered as alternate piece.</p> <p>ACTION: Enter correct weapon number.</p>
@# MISSED: ####	<p>Follows * RANGE ERR * message. Indicates error magnitude as distance in meters from target.</p> <p>ACTION: Verify all initialization and input entries. If error is excessive, select an alternate charge, weapon, or ammunition type.</p>
@# NOT FOUND	<p>No WPN DATA entered for this weapon.</p> <p>ACTION : Enter WPN DATA for this weapon, or choose alternate weapon.</p>
@#:## DANGER	<p>Warning: Friendly weapon is positioned at or near computed target location. First @# is firing weapon ID. Second @# is endangered weapon position ID.</p> <p>ACTION: Verify target and weapon location entries. If locations are correct, and endangered weapon is still in place, abort firing mission.</p>

ERROR MESSAGES (CONT)

ERROR MESSAGE	EXPLANATION/ACTION
@#:@/## DANGER	<p>Warning: Friendly FO is positioned at or near computed target location. @# is firing weapon ID. @/## is endangered FO ID.</p> <p>ACTION : Verify target and FO location entries. If locations are correct, and endangered FO is still in place, abort firing mission.</p>
Δ AZ TOO BIG	<p>Difference between safety fan LLAZ and RLAZ entries is 3200 mils or more.</p> <p>ACTION : Change safety fan LLAZ and/or RLAZ entries to obtain delta azimuth of less than 3200 mils.</p>
Δ AZ TOO SMALL	<p>Difference between safety fan LLAZ and RLAZ entries is less than 400 mils.</p> <p>ACTION : Change safety fan LLAZ and/or RLAZ entries to obtain delta azimuth of at least 400 mils.</p>
Δ RANGE TOO SMALL	<p>Difference between safety fan MIN RN and MAX RN entries is less than 200 meters.</p> <p>ACTION : Change SFTY DATA MIN RN and/or MAX RN entries to obtain delta range of 200 meters or greater.</p>
ADJ COMPLETE	<p>All weapons in sheaf have already been adjusted.</p> <p>ACTION : No further adjustments are possible within current mission.</p>
BAD AIR DENSITY	<p>Temperature and Pressure entries will not yield ballistics solution.</p> <p>ACTION: Verify Temperature and Pressure values. If correct for given MET, data is not usable in MBC.</p>
BAD CHARGE ZONE	<p>SFTY DATA, MIN CHG entry is greater than MAX CHG entry.</p> <p>ACTION : Change MIN CHG and MAX CHG entries so that MIN CHG is less than or equal to MAX CHG.</p>
BAD FO:@/## FR	<p>Fire Request message received from FO for which no initialization was entered. Corrections cannot be computed.</p> <p>ACTION : If action is required, enter FO LOC initialization data.</p>

ERROR MESSAGES (CONT)

ERROR MESSAGE	EXPLANATION/ACTION
BAD HEIGHT	<p>Absolute altitude or delta height is outside the range -400 meters to 10,000 meters.</p> <p>ACTION : Verify all altitude, height, or vertical angle entries. If all values are correct, given mission cannot be computed.</p>
BAD KNPT:### SHFT	<p>Upon receipt of FR SHIFT message, known point message is not stored in KNPT buffer.</p> <p>ACTION: If known point is valid, enter KNPT data. If known point number is in error, verbally request retransmission of corrected message.</p>
BAD POWER UP	<p>Hardware malfunction: Memory probably corrupted.</p> <p>ACTION: Power down and back up several times. If this or another power-up error occurs, check battery or power supply. If error still occurs, return MBC to next higher maintenance level .</p>
BAD ΔHEIGHT	<p>Similar to BAD HEIGHT error. Computed delta height exceeds acceptable limits.</p> <p>ACTION: Verify all altitude, height, or vertical angle entries. If all values are correct, given mission cannot be computed.</p>
BAD Δ\ WIND ###-###	<p>Direction and Velocity entries in consecutive MET datum planes yield casting and/or northing wind components that differ by more than 29 knots. ###-### indicates MET datum planes in error.</p> <p>ACTION: Verify Direction and Velocity entries for stated MET datum planes. If correct for given MET, data is not usable in MBC .</p>
BANK: FAIL	<p>Memory bank switching hardware failure.</p> <p>ACTION: Return MBC to next higher maintenance level.</p>
BAT @ NOT FOUND	<p>Initialization data not yet entered for this battery.</p> <p>ACTION: Enter initialization data for this battery, or select weapon from another battery.</p>

ERROR MESSAGES (CONT)

ERROR MESSAGE	EXPLANATION/ACTION
CHARGE VIOLATION	<p>Illegal cartridge-fuze-charge combination entry:</p> <ul style="list-style-type: none"> - 81mm, with VT fuze, at charge 0 - 107mm, with VT fuze, and charge less than 10 - 107mm, carrier-mounted, at an elevation of 1065, and a charge greater than 32 <p>ACTION: Make alternate WPN/AMMO entries to avoid the above illegal combinations.</p>
CHG TOO BIG	<p>Minimum range for user-selected charge is greater than range-to-target.</p> <p>ACTION: Leave charge field blank (MBC selects optimum charge) or enter valid smaller alternate charge. If valid charge cannot be found for these WPN/AMMO entries, make alternate WPN/AMMO entries.</p>
CHG TOO LOW	<p>User-selected charge maximum range is less than the range-to-target.</p> <p>ACTION: Leave charge field blank (MBC selects optimum charge) or enter valid larger alternate charge. If valid charge cannot be found for these WPN/AMMO entries, make alternate WPN/AMMO entries.</p>
DEFL TOO BIG	<p>Required deflection exceeds maximum left or right traverse limitations for carrier-mounted 107mm mortars.</p> <p>ACTION: Select alternate weapon for which limitations are not exceeded.</p>
DISP \$\$\$ MEM \$\$\$	<p>Follows REV NO. FAILURE error message. Indicates revision numbers for Display/Processor CCA and Memory CCA respectively.</p> <p>ACTION: Return MBC to next higher maintenance level.</p>
DUPLICATE WPNS	<p>Same weapon number entered two or more times into TFC, GUNS selection for multiple weapon missions.</p> <p>ACTION: Delete duplicate entries.</p>
E TOO BIG	<p>Computed delta easting exceeds 32767.</p> <p>ACTION: Verify all entries affecting delta easting. Also verify that MIN E and MIN N entries in SETUP data are appropriate for mission coordinates.</p>

ERROR MESSAGES (CONT)

ERROR MESSAGE	EXPLANATION/ACTION
ENTRY NOT FND	<p>Required FO, KNPT, or TGT initialization data not yet entered into appropriate memory file.</p> <p>ACTION: Enter initialization data for required FO, KNPT, or TGT, or choose alternate scenario not requiring this data.</p>
EXCESSIVE WIND	<p>Wind deviations exceed stability limitations of MBC.</p> <p>ACTION: Verify MET entries. If correct, this MET is unusable.</p>
FATAL ERR,REINIT	<p>Mission data has been corrupted.</p> <p>ACTION: End mission with EOM and restart mission from beginning.</p>
FILE EMPTY	<p>No data in initialization data buffer.</p> <p>ACTION: Verify initialization function selection under review and/or enter required initialization data.</p>
FILE FULL	<p>No more initialization data storage space available in buffer.</p> <p>ACTION: Delete unneeded data to make space for new initialization data entries.</p>
FO TOO CLOSE	<p>FO is too close to target to perform MPI mission. (Within 10 meters.)</p> <p>ACTION: Verify FO and target coordinate entries.</p>
FORMAT ERROR	<p>All valid data not entered into blank menu fields.</p> <p>ACTION: Enter all required data into blank menu fields or select alternate menu sequence using appropriate action switch.</p>
FPF LN EMPTY	<p>Selected FPF Line is currently unused.</p> <p>ACTION: Select appropriate FPF Line having stored data.</p>
GUN IS ADJUSTED	<p>Adjustments have already been completed for this weapon.</p> <p>ACTION: Select new weapon to ADJust only after all adjustments have been completed for the current weapon. Once new weapon is selected, previous adjustments are fixed and further Adjustments for those pieces are not possible.</p>

ERROR MESSAGES (CONT)

ERROR MESSAGE	EXPLANATION/ACTION
ID ASSIGNED	<p>This KNPT number or TGT number entry has already been used.</p> <p>ACTION: Choose alternate number for data storage, or delete stored data before storing new data.</p>
ILL ENTRY	<p>Illegal value entered into blank field of data entry menu.</p> <p>ACTION: Determine proper value range for data and change data entry accordingly.</p>
ILLEGAL CHARGE	<p>Manually-entered charge is invalid for selected ammunition.</p> <p>ACTION: Leave charge field blank (MBC selects optimum charge) or enter valid alternate charge.</p>
ILLEGAL . SWITCH	<p>Invalid keypress.</p> <p>ACTION: Check entry. Make only valid entries.</p>
ILLEGAL TGT NUM	<p>Target number is within target number block range assigned in SETUP.</p> <p>ACTION: Manually enter a TN outside range defined in SETUP, or notify sender to retransmit valid TN.</p>
INST:FAIL	<p>Processor failure.</p> <p>ACTION: Return MBC to next higher maintenance level.</p>
LN ALREADY INIT	<p>FPF line is already in use (initialized).</p> <p>ACTION: Select alternate FPF line or clear line to reinitialize.</p>
MAX NOT GREATER	<p>MAX Fire Line is closer than MIN Fire Line.</p> <p>ACTION: Verify MIN and MAX Fire Line entries.</p>
MODEM:FAIL	<p>Modem CCA failure.</p> <p>ACTION: Return MBC to next higher maintenance level.</p>
MSG BUFFER EMPTY	<p>No messages currently stored in message buffers.</p> <p>ACTION: Do not press MSG switch unless message lamp is blinking.</p>

ERROR MESSAGES (CONT)

ERROR MESSAGE	EXPLANATION/ACTION
MSN # UNASSIGNED	<p>Unassigned mission selected for activation.</p> <p>ACTION: Activate an alternate mission when operating on previously initiated mission.</p>
MSN ERROR	<p>Probable MBC software fault.</p> <p>ACTION: End mission and reenter. Compute mission. If error reoccurs, return MBC to next higher maintenance level.</p>
N TOO BIG	<p>Computed delta northing exceeds 32767.</p> <p>ACTION: Verify all entries affecting delta northing. Also, verify that MIN E and MIN N entries in SETUP data are appropriate for mission coordinates.</p>
NO ACTIVE MSN	<p>No missions currently stored in mission buffers or no mission presently activated.</p> <p>ACTION: Initiate new mission using GRID, SHIFT, or POLAR switch or Fire Request message; or select a currently stored mission using MSN switch and appropriate display switch.</p>
NO ADJUST DATA	<p>All required ADJust data has not yet been entered.</p> <p>ACTION: Do not press COMPUTE switch for an ADJust before viewing first ADJ data entry field (DEV).</p>
NO AVAIL MSN	<p>Mission buffers are full (three missions stored).</p> <p>ACTION: Terminate one stored mission by selecting EOM, EOMRAT, or EOMFPF. Then initiate new mission.</p>
NO CURR MET	<p>Current MET has not been initialized.</p> <p>ACTION: Enter or review appropriate NEW MET data and initialize CURRent MET by pressing UPDATE*, or select STD MET.</p>
NO FO ENTERED	<p>No FO entry in mission input data.</p> <p>ACTION: When sending digital response to manual input mission, enter FO ID when beginning mission. FO ID is entered automatically in DMD-supported missions.</p>
NO MAP MOD	<p>Computation (such as computing gun orders) requires MIN E and MIN N coordinates, and none were assigned in SETUP data entry.</p> <p>ACTION: Always initialize SETUP data completely (MIN E and MIN N) before performing compute functions.</p>

ERROR MESSAGES (CONT)

ERROR MESSAGE	EXPLANATION/ACTION
NO OUTPUT DATA	<p>Review of FIRE DATA or SFTY DATA or other operation (such as ADJ, REG, or REPLOT) requires existing output data.</p> <p>ACTION: Press COMPUTE switch after properly entering appropriate mission input data.</p>
NO SHEAF DATA	<p>SPECIAL sheaf selected, but without width or direction entry.</p> <p>ACTION: Enter all sheaf data before pressing COMPUTE switch.</p>
NO TGT DATA	<p>Insufficient target location data.</p> <p>ACTION: Press MSN switch, then sequence through mission input data menus. Enter all input data on all entry menus.</p>
NO TGT NUM	<p>Target numbers not yet assigned for target block definition in SETUP data.</p> <p>ACTION: Assign new block of target numbers using SETUP initialization menu sequence.</p>
NO TRIANGLE	<p>Nonconvergent line segments in SURVey Intersection or RESection problem.</p> <p>ACTION: Verify input angle and coordinate data entries.</p>
NO WPN DATA	<p>Weapon not yet selected using WPN/AMMO switch.</p> <p>ACTION: Enter weapon on WPN select menu before pressing COMPUTE switch.</p>
POWER FAILURE	<p>MBC powered down by means other than ON/OFF switch e.g., by removing battery or external power.</p> <p>ACTION: Turn power off using ON/OFF switch before disconnecting power source.</p>
PTS AVAIL:##	<p>Remaining number of points available in Fire Zone storage buffer, when new Fire Zone entry contains too many points.</p> <p>ACTION: Define new Fire Zone with fewer points or delete unused Fire Zones to provide additional buffer storage space.</p>

ERROR MESSAGES (CONT)

ERROR MESSAGE	EXPLANATION/ACTION
RAM:FAIL @##	<p>MICRO test Random Access Memory failure.</p> <p>ACTION: Return MBC to next higher maintenance level.</p>
RANGE TOO SMALL	<p>Range to target is zero, or when entering FIRE ZONES data, distance between points is less than 10 meters.</p> <p>ACTION: Verify mission input entry or FIRE ZONES data entry.</p>
REG TOO BIG	<p>Range corrections exceed 999 meters when computing a Registration.</p> <p>ACTION: Register target only when range corrections are 999 meters or less (typically much less).</p>
REV NO. FAILURE	<p>Memory CCA and Display/Processor CCA have incompatible revision numbers.</p> <p>ACTION: Return MBC to next higher maintenance level.</p>
RNG TOO BIG	<p>Entered or computed range is too large.</p> <p>ACTION: Change distance or coordinate entries to reduce range to acceptable value.</p>
ROM: FAIL @##	<p>MICRO test Read Only Memory failure.</p> <p>ACTION: Return MBC to next higher maintenance level.</p>
SAFETY VIOLATION	<p>Impact point is outside defined safety fan boundaries.</p> <p>ACTION: Verify target location and safety data entries. Reenter if necessary. No further action can be taken.</p>
SINGLE WPN ONLY	<p>More than one weapon is designated on TFC sequence GUNS: @# _____ menu but selected TFC CONTROL allows only one weapon.</p> <p>ACTION: Select TFC CONTROL function allowing multiple weapons, or do not enter additional weapons.</p>
SPC SHEAF ERROR	<p>Weapon registration is illegal while in TFC CONTROL (SPECIAL SHEAF) .</p> <p>ACTION: To perform a registration, change TFC CONTROL selection.</p>

ERROR MESSAGES (CONT)

ERROR MESSAGE	EXPLANATION/ACTION
SUPERSONIC	<p>Calculated shell velocity exceeds Mach 1.</p> <p>ACTION: Prevailing nonstandard conditions provide inaccurate MBC calculations. Verify all nonstandard initialization entries including AMMO powder Temperature, AMMO Weight corrections, all MET data, and target and weapon ALTitudes.</p>
TEMP OUT OF RNGE	<p>Powder temperature entry outside range (-70 to 140).</p> <p>ACTION: Verify that powder temperature entry is within allowable range.</p>
TEMP TOO LOW	<p>MBC cannot compute gun orders for 107mm mortars with extension when powder temperature is below -30 degrees.</p> <p>ACTION: Mission cannot be fired under given conditions. Verify ammo powder temperature and target location entries.</p>
TEMP TOO LOW	<p>Air temperature in MET data is below 1536 (153.6 degrees Kelvin or -183.2 degrees Fahrenheit).</p> <p>ACTION: Verify that air temperature entry is 1536 or above.</p>
TGT HIGH/RN BIG	<p>Target is beyond maximum range or maximum altitude, at maximum allowable safe charge, and charge has not been manually entered.</p> <p>ACTION: Mission cannot be fired under given conditions. Verify WPN/AMMO and target location entries.</p>
TGT LOW/RN SMALL	<p>Target is below minimum range or minimum altitude, at minimum allowable safe charge, and charge has not been manually entered.</p> <p>ACTION: Mission cannot be fired under given conditions. Verify WPN/AMMO and target location entries.</p>
TGT TOO HIGH	<p>Target altitude is greater than 90 percent of MAX ORD of computed flight trajectory; reliable results cannot be obtained.</p> <p>ACTION: Increase charge or elevation entries if possible.</p>

ERROR MESSAGES (CONT)

ERROR MESSAGE	EXPLANATION/ACTION
TN NOT ASSIGNED	<p>Received message target number does not match stored target numbers.</p> <p>ACTION: Notify message sender that there is no active mission for this target number.</p>
TN OVERFLOW	<p>Operation requires target number assignment by MBC (such as starting new mission). No more numbers are available in assigned target block.</p> <p>ACTION: Assign new block of target numbers to MBC using SETUP initialization menu sequence.</p>
TOO FEW PTS	<p>Fire Zone defined with less than three points.</p> <p>ACTION: Define all Fire Zones with three or more points.</p>
TOO MANY POINTS	<p>Fire Zone defined using more than the allowable number of points.</p> <p>ACTION: Define Fire Zone using fewer points, or delete unneeded Fire Zone(s).</p>
WEAK TRIANGLE	<p>SURVey Intersection or RESection defining lines do not intersect within allowable angular range (22.5 degrees to 175.5 degrees).</p> <p>ACTION: Verify FO and KNPT location entries. Select KNPT to give angular deviation within allowable range.</p>
WEIGHT TOO BIG	<p>When entering ammo weight corrections in AMMO DATA, weight entry is greater than 52 pounds.</p> <p>ACTION: Verify projectile weight entry.</p>
WEIGHT TOO LOW	<p>When entering ammo weight corrections in AMMO DATA, weight entry is less than 13 pounds.</p> <p>ACTION: Verify projectile weight entry.</p>

INDEX

Subject	Page
A	
Abbreviations	Glossary 1
Action Switches	2-4
ADJ Switch	2-7, 2-102
Alpha Entry	2-13
AMMO DATA Switch	2-3, 2-65
Assembly And Preparation For Use	2-24
B	
Battery Replacement	2-25
BRT Switch	2-3, 2-58
C	
Cautions	2-30, 2-31, 2-34
Checks/Adjustments	3-2
Chemical Decontamination Procedures	2-160
Cleaning	3-2
Common Name	1-3
Common Tools And Equipment	4-1
Communications Interface Connections	2-32
Components Of End Item And Basic Issue Items Lists	C-1
COMPUTE Switch	2-5, 2-99
Controls and Indicators	2-1
Correction Entry	2-15, 2-19
D	
Data Entry	2-12
Data Review.	2-82
Default Entry.	2-13
Description Of Major Components	1-5
Destruction Of Army Materiel To Prevent Enemy Use	1-2
Direction Entry.	2-16
Disassembly And Assembly	3-2
Display Abbreviations And Words	Glossary 2
Display Switches	2-9
DMD - Supported Missions	2-144
E	
Emergency Procedures	2-160
EOM Switch	2-5, 2-120
Equipment Configuration.	1-7
Equipment Data Table	1-6
Equipment Description And Data	1-4
Error Messages	Glossary 26

INDEX (CONT)

Subject	Page
Expendable/Durable Supplies And Material List	D-1
External Power Connections	2-30
F	
FIRE DATA Switch	2-8, 2-119
Fire Mission Switches	2-6
FIRE ZONES Switch	2-3, 2-70
First Aid Data	a
FO LOC Switch	2-2, 2-74
Fording And Swimming Operations	2-159
FPF Switch	2-7, 2-122
G	
Glossary	Glossary 1
GRIDSwitch	2-7, 2-96
H	
How To Use This Manual	iv
I	
Index	Index 1
Initial Checks	2-35
Initialization	2-53
Initialization Data : : :	2-54
Initialization Data Review	2-82
Initialization Procedure	2-57
Initialization Switches	2-2
Inspection	3-1
Installation Instructions	4-2
J	
Jamming And ECM Procedures	2-160
K	
Keys	2-6
KNPT/TGT Switch	2-3, 2-77
L	
LED Indicators	2-10
Location of Major Components	1-5
Lubrication Instructions	3-1

INDEX (CONT)

Subject	Page
M	
Maintenance Allocation Chart	B-1
Maintenance Forms, Records, And Reports	1-2
Manual Input Missions.	2-85
MET Switch	2-3,2-67
MSN Switch	2-5,2-117
Multiple Choice Entry	2-18
N	
Nomenclature Cross-Reference List	1-3
Numeric Entry	2-14
O	
Official Nomenclature	1-3
Operating Conditions	2-35
Operating Instructions	2-1
Operational Check (Organizational)	4-4
Operation In Unusual Weather	2-159
Operation Under Unusual Conditions	2-159
Operator Maintenance	3-1
Operator PMCS Table	2-22
Operator Preventive Maintenance Checks And Services (PMCS)	2-21
Organizational Maintenance	4-1
Organizational PMCS Table	4-2
Organizational Preventive Maintenance Checks And Services (PMCS)	4-2
Output Switches	2-8
P	
Physical Inspection	4-3
PMCS (Operator)	2-21
PMCS (Organizational)	4-2
PMCS Procedures (Operator)	2-21
Preliminary Servicing And Adjustment Of Equipment	4-2
Preparation For Movement	2-159
Preparation For Storage Or Shipment	1-2, 4-6
Principles Of Operation	1-11
Purpose.	1-1, 1-11
R	
Received Messages For Fire Mission Processing And Control	2-146
References	A-1

INDEX (CONT)

Subject	Page
REG DATA Switch	2-2, 2-79
Removal And Installation	3-2
Removing From Operation	2-159
Repair (Operator)	3-2
Repair Or Replacement	4-4
Repair Parts	4-1
Repair Parts And Special Tools List	E-1
Repair Parts, Special Tools, TMDE, And Support Equipment.	4-1
Reporting Equipment Improvement Recommendations (EIR)	1-2
Return To Ready Display	2-20
S	
Safety, Care, And Handling	1-10
Sample DMD - Supported Grid Fire Mission	2-147
Sample FPF Mission	2-121
Sample Grid Fire Mission	2-94
Sample Safety Data Entry	2-91
Sample Survey Problem	2-88
Scope.	1-1
Self-Test	2-36
Service Upon Receipt Of Materiel	4-2
SETUP Switch.	2-2, 2-59
SFTY DATA Switch	2-8, 2-91
Special Tools, TMDE, And Support Equipment	4-1
T	
Target Type And Subtype Mnemonics	Glossary 20
Test (Operator)	3-3
TEST Switch	2-3, 2-58
TFC Switch	2-7, 2-112
Troubleshooting (Organizational)	4-3
Troubleshooting Procedures (Operator)	3-1
W	
Warnings	a, 2-37
WPN AMMO Switch	2-7, 2-97
WPN DATA Switch	2-2, 2-62
X	
XMIT Switch	2-4, 2-100 2-150, 2-154

By Order of the Secretary of the Army:

JOHN A. WICKHAM, JR.
General, United States Army
Chief of Staff

Official:

DONALD J. DELANDRO
Brigadier General, United States Army
The Adjutant General

DISTRIBUTION:

To be distributed in accordance with DA Form 12-41, Operator's and Organizational Maintenance requirements for Computer, Ballistic, Mortar, M23.

*U.S. GOVERNMENT PRINTING OFFICE: 1985-554-049:10185

RECOMMENDED CHANGES TO EQUIPMENT TECHNICAL MANUALS



SOMETHING WRONG WITH THIS MANUAL?

THEN... JOT DOWN THE DOPE ABOUT IT ON THIS FORM, TEAR IT OUT, FOLD IT AND DROP IT IN THE MAIL!

FROM: (YOUR UNIT'S COMPLETE ADDRESS)
 Commander
 Stateside Army Depot
 ATTN: AMSTA-US
 Stateside, N.J. 07703

DATE 10 July 1975

PUBLICATION NUMBER: TM 11-5840-340-12 DATE: 23 Jan 74 TITLE: Radar Set AN/SPC-76

BE EXACT... PIN-POINT WHERE IT IS

IN THIS SPACE TELL WHAT IS WRONG AND WHAT SHOULD BE DONE ABOUT IT:

PAGE NO.	PARA-GRAPH	FIGURE NO.	TABLE NO.	
2-25	2-28			<p>Recommend that the installation antenna alignment procedure be changed through to specify a 2° IFF antenna lag rather than 1°.</p> <p>REASON: Experience has shown that with only a 1° lag, the antenna servo system is too sensitive to wind gusting in excess of 47 knots, and has a tendency to rapidly accelerate and decelerate as it hunts, causing strain to the drive train. Hunting is minimized by adjusting the lag to 2° without degradation of operation.</p>
3-10	3-3		3-1	<p>Item 5, Function column. Change "2 db" to "3db."</p> <p>REASON: The adjustment procedure for the TRANS POWER FAULT indicator calls for a 3 db (500 watts) adjustment to light the TRANS POWER FAULT indicator.</p>
5-6	5-8			<p>Add new step f.1 to read, "Replace cover plate removed in step e.1, above."</p> <p>REASON: To replace the cover plate.</p>
		FO3		<p>Zone C 3. On J1-2, change "+24 VDC to "+5 VDC."</p> <p>REASON: This is the output line of the 5 VDC power supply. + 24 VDC is the input voltage.</p>

TEAR ALONG DOTTED LINE

TYPED NAME, GRADE OR TITLE, AND TELEPHONE NUMBER
 SSG I. M. DeSpirito 999-1776

SIGN HERE:
SSG I. M. DeSpirito

FILL IN YOUR
UNIT'S ADDRESS

FOLD BACK

TEAR ALONG PERFORATED LINE

DEPARTMENT OF THE ARMY



OFFICIAL BUSINESS
PENALTY FOR PRIVATE USE, \$300

NO POSTAGE
NECESSARY
IF MAILED
IN THE
UNITED STATES

BUSINESS REPLY MAIL

FIRST CLASS PERMIT NO. 12062 WASHINGTON, DC

POSTAGE WILL BE PAID BY DEPARTMENT OF THE ARMY



COMMANDER
US ARMY ARMAMENT, MUNITIONS
AND CHEMICAL COMMAND
ATTN: AMSMC-MAS
ROCK ISLAND, IL 61201-9990

FILL IN YOUR
UNIT'S ADDRESS

FOLD BACK

DEPARTMENT OF THE ARMY



OFFICIAL BUSINESS
PENALTY FOR PRIVATE USE, \$300

NO POSTAGE
NECESSARY
IF MAILED
IN THE
UNITED STATES

BUSINESS REPLY MAIL

FIRST CLASS PERMIT NO. 12062 WASHINGTON, DC

POSTAGE WILL BE PAID BY DEPARTMENT OF THE ARMY

COMMANDER
US ARMY ARMAMENT, MUNITIONS
AND CHEMICAL COMMAND
ATTN: AMSMC-MAS
ROCK ISLAND, IL 61201-9990



TEAR ALONG PERFORATED LINE

FILL IN YOUR
UNIT'S ADDRESS

FOLD BACK

TEAR ALONG PERFORATED LINE

DEPARTMENT OF THE ARMY



OFFICIAL BUSINESS
PENALTY FOR PRIVATE USE, \$300

NO POSTAGE
NECESSARY
IF MAILED
IN THE
UNITED STATES

BUSINESS REPLY MAIL

FIRST CLASS PERMIT NO. 12062 WASHINGTON, DC

POSTAGE WILL BE PAID BY DEPARTMENT OF THE ARMY

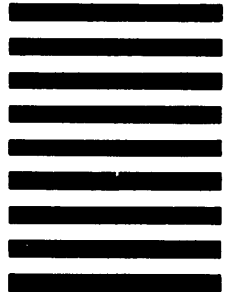

COMMANDER
US ARMY ARMAMENT, MUNITIONS
AND CHEMICAL COMMAND
ATTN: AMSMC-MAS
ROCK ISLAND, IL 61201-9990

THE METRIC SYSTEM AND EQUIVALENTS

LINEAR MEASURE

1 Centimeter = 10 Millimeters = 0.01 Meters = 0.3937 Inches
 1 Meter = 100 Centimeters = 1000 Millimeters = 39.37 Inches
 1 Kilometer = 1000 Meters = 0.621 Miles

WEIGHTS

1 Gram = 0.001 Kilograms = 1000 Milligrams = 0.035 Ounces
 1 Kilogram = 1000 Grams = 2.2 Lb
 1 Metric Ton = 1000 Kilograms = 1 Megagram = 1.1 Short Tons

LIQUID MEASURE

1 Milliliter = 0.001 Liters = 0.0338 Fluid Ounces
 1 Liter = 1000 Milliliters = 33.82 Fluid Ounces

SQUARE MEASURE

1 Sq Centimeter = 100 Sq Millimeters = 0.155 Sq Inches
 1 Sq Meter = 10,000 Sq Centimeters = 10.76 Sq Feet
 1 Sq Kilometer = 1,000,000 Sq Meters = 0.386 Sq Miles

CUBIC MEASURE

1 Cu Centimeter = 1000 Cu Millimeters = 0.06 Cu Inches
 1 Cu Meter = 1,000,000 Cu Centimeters = 35.31 Cu Feet

TEMPERATURE

$\frac{5}{9} (^{\circ}\text{F} - 32) = ^{\circ}\text{C}$
 212^o Fahrenheit is equivalent to 100^o Celsius
 90^o Fahrenheit is equivalent to 32.2^o Celsius
 32^o Fahrenheit is equivalent to 0^o Celsius
 $\frac{9}{5} \text{C}^{\circ} + 32 = \text{F}^{\circ}$

APPROXIMATE CONVERSION FACTORS

<u>TO CHANGE</u>	<u>TO</u>	<u>MULTIPLY BY</u>
Inches	Centimeters	2.540
Feet	Meters	0.305
Yards	Meters	0.914
Miles	Kilometers	1.609
Square Inches	Square Centimeters	6.451
Square Feet	Square Meters	0.093
Square Yards	Square Meters	0.836
Square Miles	Square Kilometers	2.590
Acres	Square Hectometers	0.405
Cubic Feet	Cubic Meters	0.028
Cubic Yards	Cubic Meters	0.765
Fluid Ounces	Milliliters	29.573
Pints	Liters	0.473
Quarts	Liters	0.946
Gallons	Liters	3.785
Ounces	Grams	28.349
Pounds	Kilograms	0.454
Short Tons	Metric Tons	0.907
Pound-Feet	Newton-Meters	1.356
Pounds per Square Inch	Kilopascals	6.895
Miles per Gallon	Kilometers per Liter	0.425
Miles per Hour	Kilometers per Hour	1.609

<u>TO CHANGE</u>	<u>TO</u>	<u>MULTIPLY BY</u>
Centimeters	Inches	0.394
Meters	Feet	3.280
Meters	Yards	1.094
Kilometers	Miles	0.621
Square Centimeters	Square Inches	0.155
Square Meters	Square Feet	10.764
Square Meters	Square Yards	1.196
Square Kilometers	Square Miles	0.386
Square Hectometers	Acres	2.471
Cubic Meters	Cubic Feet	35.315
Cubic Meters	Cubic Yards	1.308
Milliliters	Fluid Ounces	0.034
Liters	Pints	2.113
Liters	Quarts	1.057
Liters	Gallons	0.264
Grams	Ounces	0.035
Kilograms	Pounds	2.205
Metric Tons	Short Tons	1.102
Newton-Meters	Pound-Feet	0.738
Kilopascals	Pounds per Square Inch	0.145
Kilometers per Liter	Miles per Gallon	2.354
Kilometers per Hour	Miles per Hour	0.621

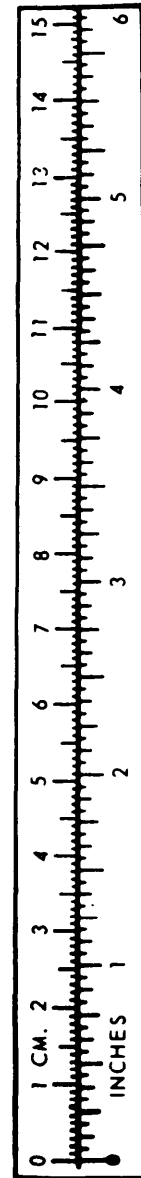

TA089991

This fine document...

Was brought to you by me:



[Liberated Manuals -- free army and government manuals](#)

Why do I do it? I am tired of sleazy CD-ROM sellers, who take publicly available information, slap “watermarks” and other junk on it, and sell it. Those masters of search engine manipulation make sure that their sites that sell free information, come up first in search engines. They did not create it... They did not even scan it... Why should they get your money? Why are not letting you give those free manuals to your friends?

I am setting this document FREE. This document was made by the US Government and is NOT protected by Copyright. Feel free to share, republish, sell and so on.

I am not asking you for donations, fees or handouts. If you can, please provide a link to liberatedmanuals.com, so that free manuals come up first in search engines:

<A HREF=<http://www.liberatedmanuals.com/>>Free Military and Government Manuals

- Sincerely
Igor Chudov
<http://igor.chudov.com/>
- [Chicago Machinery Movers](#)