

TM-H6000IV

Technical Reference Guide

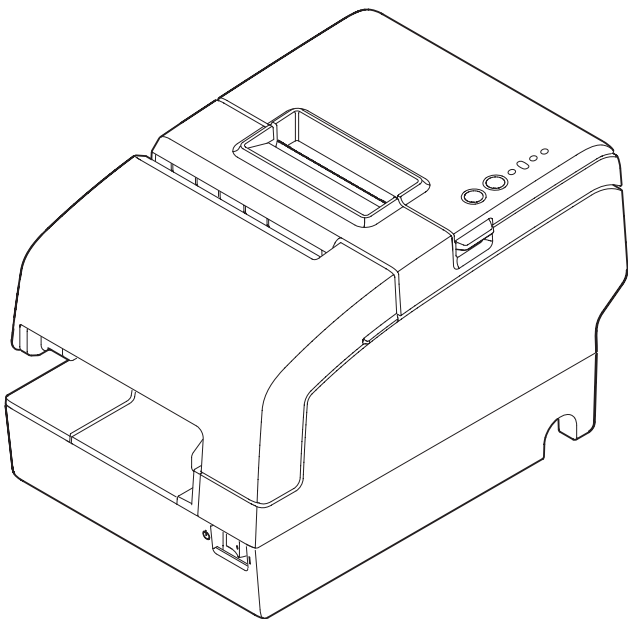

Product Overview

Describes features and general specifications for the product.

Setup

Describes setup and installation of the product and peripherals.

Application Development Information

Describes how to control the printer and necessary information when you develop applications.

Handling

Describes how to handle the product.

Replacement of the TM-H6000III

Describes precautions for replacement.

Appendix

Describes interfaces, connectors, and character code tables.

Cautions

- No part of this document may be reproduced, stored in a retrieval system, or transmitted in any form or by any means, electronic, mechanical, photocopying, recording, or otherwise, without the prior written permission of Seiko Epson Corporation.
- The contents of this document are subject to change without notice. Please contact us for the latest information.
- While every precaution has been taken in the preparation of this document, Seiko Epson Corporation assumes no responsibility for errors or omissions.
- Neither is any liability assumed for damages resulting from the use of the information contained herein.
- Neither Seiko Epson Corporation nor its affiliates shall be liable to the purchaser of this product or third parties for damages, losses, costs, or expenses incurred by the purchaser or third parties as a result of: accident, misuse, or abuse of this product or unauthorized modifications, repairs, or alterations to this product, or (excluding the U.S.) failure to strictly comply with Seiko Epson Corporation's operating and maintenance instructions.
- Seiko Epson Corporation shall not be liable against any damages or problems arising from the use of any options or any consumable products other than those designated as Original EPSON Products or EPSON Approved Products by Seiko Epson Corporation.

Trademarks

EPSON and ESC/POS are registered trademarks of Seiko Epson Corporation in Japan and other countries/regions.

Microsoft and Windows are registered trademarks of Microsoft Corporation.

ESC/POS[®] Command System



EPSON ESC/POS is a proprietary POS printer command system that includes patented or patent-pending commands. ESC/POS is compatible with all types of EPSON POS printers and displays (excluding the TM-C100 printer).

ESC/POS is designed to reduce the processing load on the host computer in POS environments. It comprises a set of highly functional and efficient commands and also offers the flexibility to easily make future upgrades.

For Safety

Key to Symbols

The symbols in this manual are identified by their level of importance, as defined below. Read the following carefully before handling the product.

 WARNING	You must follow warnings carefully to avoid serious bodily injury.
 CAUTION	Provides information that must be observed to prevent damage to the equipment or loss of data. <ul style="list-style-type: none">• Possibility of sustaining physical injuries.• Possibility of causing physical damage.• Possibility of causing information loss.
CAUTION	Provides information that must be observed to avoid damage to your equipment or a malfunction.
NOTE	Provides important information and useful tips.

Warnings



WARNING

- To avoid risk of electric shock, do not set up this product or handle cables during a thunderstorm
- **Never insert or disconnect the power plug with wet hands.**
Doing so may result in severe shock.
- **Handle the power cable with care.**
Improper handling may lead to fire or electric shock.
 - * Do not modify or attempt to repair the cable.
 - * Do not place any heavy object on top of the cable.
 - * Avoid excessive bending, twisting, and pulling.
 - * Do not place the cable near heating equipment.
 - * Check that the plug is clean before plugging it in.
 - * Be sure to push the plug all the way in.
- **Be sure to use the specified power source.**
Connection to an improper power source may cause fire or shock.
- **Do not place multiple loads on the power outlet.**
Overloading the outlet may lead to fire.
- **Shut down your equipment immediately if it produces smoke, a strange odor, or unusual noise.**
Continued use may lead to fire. Immediately unplug the equipment and contact your dealer or a Seiko Epson service center for advice.
- **Never attempt to repair this product yourself.**
Improper repair work can be dangerous.
- **Never disassemble or modify this product.**
Tampering with this product may result in injury or fire.
- **Do not allow foreign matter to fall into the equipment.**
Penetration by foreign objects may lead to fire.
- **If water or other liquid spills into this equipment, do not continue to use it.**
Continued use may lead to fire. Unplug the power cord immediately and contact your dealer or a Seiko Epson service center for advice.
- **If you open the DIP switch cover, be sure to close the cover and tighten the screw after adjusting the DIP switch.**
Using this product with the cover open may cause fire or electric shock.
- **Do not use aerosol sprayers containing flammable gas inside or around this product.**
Doing so may cause fire.

Cautions



- **Do not connect cables in ways other than those mentioned in this manual.**
Different connections may cause equipment damage or fire.
- **Be sure to set this equipment on a firm, stable, horizontal surface.**
The product may break or cause injury if it falls.
- **Do not use this product in locations subject to high humidity or dust levels.**
Excessive humidity and dust may cause equipment damage or fire.
- **Do not place heavy objects on top of this product. Never stand or lean on this product.**
Equipment may fall or collapse, causing breakage and possible injury.
- **Take care not to injure your fingers on the manual cutter:**
 - * When you remove printed paper.
 - * When you perform other operations, such as loading/replacing roll paper.
- **Do not open the roll paper cover without taking the necessary precautions, as this can result in injury from the autocutter fixed blade.**
- **To ensure safety, unplug this product before leaving it unused for an extended period.**

Restriction of Use

When this product is used for applications requiring high reliability/safety, such as transportation devices related to aviation, rail, marine, automotive; disaster prevention devices; various safety devices; or functional/precision devices, etc., you should use this product only after giving consideration to including fail-safes and redundancies into your design to maintain safety and total system reliability. Because this product was not intended for use in applications requiring extremely high reliability/safety, such as aerospace equipment, main communication equipment, nuclear power control equipment, or medical equipment related to direct medical care, etc., please make your own judgement on this product's suitability after a full evaluation.

About this Manual

Aim of the Manual

This manual was created to provide information on the development, design, and installation of POS systems and the development and design of printer applications for developers.

Manual Content

The manual is made up of the following sections:

Chapter 1	Product Overview
Chapter 2	Setup
Chapter 3	Application Development Information
Chapter 4	Handling
Chapter 5	Replacement of the TM-H6000III
Appendix	Specifications of Interfaces and Connectors Character Code Tables

Contents

■ For Safety	3
Key to Symbols	3
Warnings	4
Cautions.....	5
■ Restriction of Use	5
■ About this Manual	6
Aim of the Manual.....	6
Manual Content	6
<hr/>	
Product Overview	11
■ Features	11
■ Product Configurations	13
Interfaces	13
Colors	13
Accessories.....	14
■ Part Names and Functions	15
Power Switch	15
Power Switch Cover.....	15
Control Panel	16
Offline	17
Connectors.....	18
■ Error Status	19
Automatically Recoverable Errors	19
Recoverable Errors.....	19
Unrecoverable Errors	20
■ NV Memory (Non-Volatile Memory)	22
NV Graphics Memory.....	22
User NV Memory	22
Memory Switches.....	23
R/E (Receipt Enhancement)	23
User-defined Page	23
Maintenance Counter	23
■ Product Specifications	24
Printing Specifications	25
Character Specifications	27
Paper Specifications.....	28
Printable Area	31
Printing and Cutting Positions	34
Ribbon Cassette	34
MICR Reader (Factory-Installed Option)	35
Electrical Characteristics	36

Reliability	37
Environmental Conditions	38
External Dimensions and Mass.....	39
■ Option Specifications	40
Power Supply Unit (PS-180)	40

Setup 41

■ Flow of Setup.....	41
■ Installing the Printer.....	42
Important Notes	42
■ Adjusting the Paper Roll Near-End (NE) Sensor.....	43
■ Changing the Paper Width.....	44
■ Setting the DIP Switches.....	45
Setting Procedure.....	45
For Serial Interface.....	46
For Parallel Interface	48
For Built-in USB Interface	49
For Ethernet/Wireless LAN Interface	50
Selecting the Print Density (DIP Switches 2-3/2-4).....	51
Selecting the BUSY Status	52
■ Connecting the Printer to the Host Computer.....	53
For Serial Interface.....	53
For Parallel Interface	56
For USB Interface.....	57
For Ethernet Interface	59
For Wireless LAN Interface	61
■ Connecting the Power Supply Unit (PS-180)	62
Connecting the Power Supply Unit	62
■ Attaching the Connector Cover.....	64
■ Setting the Memory Switches/Receipt Enhancement.....	65
Functions	66
■ Connecting the Cash Drawer	71
Connecting the Drawer Kick-out Cable.....	71

Application Development Information..... 73

■ How to Control the Printer.....	73
Selecting a Driver	73
ESC/POS Commands	74

■ Software and Manuals	83
How to Get Drivers, Manuals, and the Utility	83
Printer Drivers.....	83
Utilities.....	85
■ Setting/Checking Modes	86
Self-test Mode	86
Hexadecimal Dumping Mode	89
NV Graphics Print Mode	90
Receipt Enhancement Information Print Mode.....	92
Memory Switch Setting Mode.....	93

Handling **95**

■ Usage Precautions	95
■ Installing and Replacing the Ribbon Cartridge	95
Installing and Replacing the Ribbon Cartridge for E/P.....	97
■ Installing and Replacing Paper	99
Inserting Slip Paper	99
Inserting Validation Paper (For Validation Models).....	101
Installing and Replacing Roll Paper.....	102
■ Removing Jammed Paper	104
Removing Jammed Slip Paper.....	104
Removing Jammed Roll Paper	105
■ Cleaning the Printer	106
Cleaning the Printer Case	106
Cleaning the Thermal Head.....	106
Cleaning the MICR Head (For Models with the MICR Reader).....	107
■ Preparing for Transport	108

Replacement of the TM-H6000III **109**

■ Compatibility	109
Printing	109
Number of Head Energizing Parts for Receipt Printing	109
Printable Area	109
Cutting Method	109
Receive Buffer	110
Memory Capacity.....	110
Electrical Characteristics	110
DIP Switches	110
Printer Status.....	110
Logo Registration.....	110
Driver Compatibility	111

Two-Color Printing	111
Ink Ribbon Cartridge	111
Overall Dimensions	112

■ **Additional Functions and Functional Improvements** 113

Print Speed	113
Receipt Print Density	113
Slip Paper	114
Bar codes	114
Tone	114
Interface	114
Connection of Customer Display	115
Customized Value	115
R/E Information Printing Mode	115
Memory Switch Setting Mode	116
Maintenance Counter	116
Power Supply Unit Capacity	116
USB Low Power Consumption Mode	116

Appendix 117

■ **Specifications of Interfaces and Connectors** 117

RS-232 Serial Interface	117
IEEE 1284 Parallel Interface	120
USB (Universal Serial Bus) Interface	123

■ **Character Code Tables** 124

Common to All Pages	124
Page 0 (PC437: USA, Standard Europe)	125
Page 1 (Katakana)	126
Page 2 (PC850: Multilingual)	127
Page 3 (PC860: Portuguese)	128
Page 4 (PC863: Canadian-French)	129
Page 5 (PC865: Nordic)	130
Page 16 (WPC1252)	131
Page 17 (PC866: Cyrillic #2)	132
Page 18 (PC852: Latin2)	133
Page 19 (PC858: Euro)	134
Page 254 (User-Defined Page)	135
Page 255 (User-Defined Page)	136
International Character Sets	137

Product Overview

This chapter describes features and specifications of the product.

Features

The TM-H6000IV is a high-end POS printer that can print on both slip paper (checks) and roll paper (receipts).

The features are as follows:

Slip printing

- An optional Magnetic Ink Character Recognition (MICR) reader and an optional endorsement printer (E/P) enable the printer to perform consecutive reading of MICR characters, endorsement printing, and front printing, in a single pass of a check.
- High throughput using bidirectional minimum distance printing.
- A mechanical form stopper gives stability to slip paper.
- Opening the front carriage unit makes removing jammed paper easy.
- The validation model printer can print an 8-line validation.

Receipt printing

- High-speed printing enables issuing of batch receipts.
- Graphics are also printed with high-speed printing.
- Multi-tone graphics printing is possible.
- Bar code and two-dimensional symbol printing is possible.
- Easy drop-in paper loading.
- An autocutter is standard equipment.
- Paper-saving function is supported.

Software

- Command protocol is based on the ESC/POS Proprietary Command System.
- OPOS ADK, JavaPOS ADK, and Windows printer drivers are available.
- Automatic Status Back (ASB) function that automatically transmits changes in the printer status is supported.
- A maintenance counter function is supported.

Interfaces

- Various interface boards (EPSON UB series) can be used.
- A built-in USB interface is also available for serial/parallel interface models.

Environment

ENERGY STAR qualified. (Some configurations may be exempted, depending on their components.)

Others

- Small footprint and simple design.
- Direct connection of EPSON customer display series (DM-D) is possible.

Product Configurations

There are two models of the TM-H6000IV: a standard model that can perform slip printing and receipt printing and a validation model that can also perform validation printing.

An optional MICR reader that can read magnetic ink characters is available for both of the models. Also, an endorsement printer (E/P) that can print on the back of checks is available for the standard model.

	Validation	MICR reader	E/P
Standard models	Not equipped	Equipped/ Not equipped	Equipped/ Not equipped
Validation models	Equipped	Equipped/ Not equipped	Not equipped

Interfaces

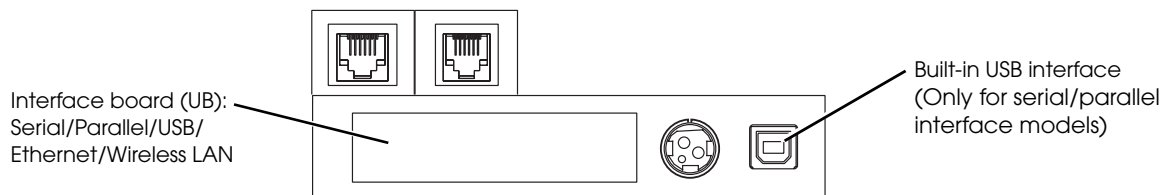

- Serial UB + built-in USB interface model
- Parallel UB + built-in USB interface model
- USB interface model
- Ethernet interface model
- Wireless LAN interface model

Colors

- ECW (Epson Cool White)
- EDG (Epson Dark Gray)

Accessories

Included

- Thermal roll paper (for operation check)
- Ink ribbon cartridge (Model: ERC-32, ERC-43*¹)
- Power switch cover
- Connector cover
- User's manual
- Warranty certificate*²

*1: Only for the model with the endorsement printer.

*2: May not be included, depending on the model.

Options

- AC adapter (Model: PS-180)
- AC cable (Model: AC-170)
- Interface boards (UB series)
- EPSON customer display series (DM-D)
- Paper guide for 58 mm width paper (Model: PG-58II)

NOTE	For Energy Star-compatible models, use only the AC adapter that came with the printer.
-------------	--

Part Names and Functions

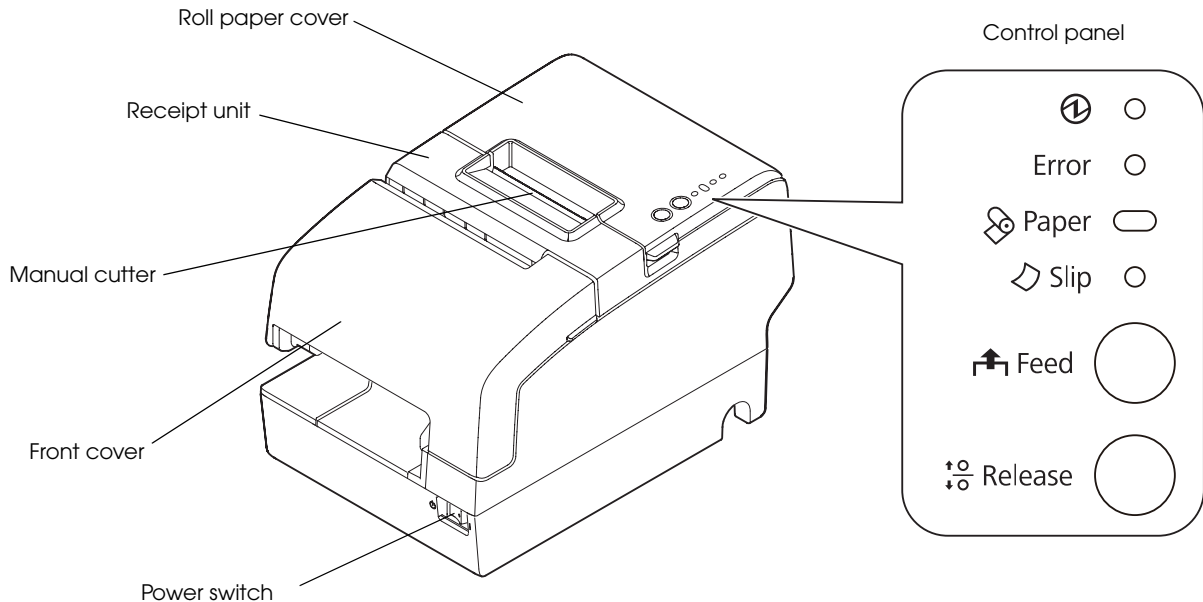

Power Switch

Turns the printer on or off. The marks on the switch: ( : OFF / | : ON)

CAUTION

Before turning the printer off, it is recommended that you send a power-off command to the printer. If you use the power-off sequence, the latest maintenance counter values are saved. (Maintenance counter values are usually saved every two minutes.)

For detailed information about ESC/POS commands, see the ESC/POS Application Programming Guide.

Power Switch Cover

Install the power switch cover included with the printer to prevent inadvertent changing of the power switch, to prevent tampering, and to improve the appearance of the printer.

To reset the printer when the power switch cover is installed, insert a long, thin object (such as the end of a paper clip) into the hole in the power switch cover and press the power switch.

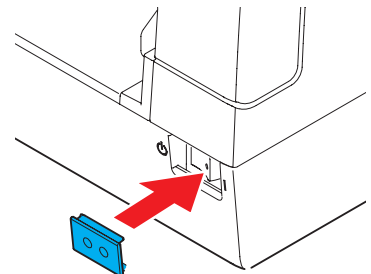

WARNING

If an accident occurs with the power switch cover attached, unplug the power cord immediately.

Continued use of the printer may cause fire or shock.

Control Panel

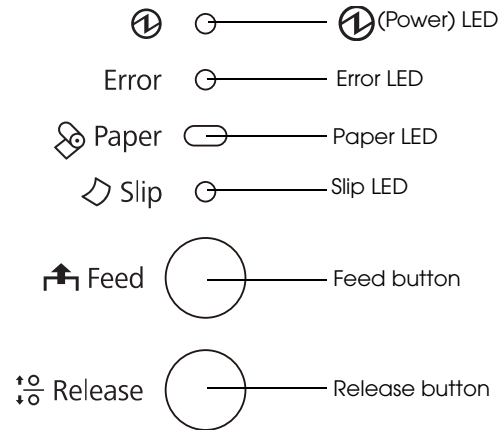

Power LED (Green)

- Lights when the power supply is on.
- Goes out when the power supply is turned off.

Error LED (Orange)

Lights or flashes when the printer is offline.

- Lights after the power is turned on or after a reset (offline). Automatically goes out when the printer is ready.
- Lights when the end of the roll paper is detected and printing has stopped (offline). If this happens, replace the roll paper.
- Flashes when an error occurs. (For details about the flash codes, see "[Error Status](#)" on page 19.)
- Goes out during regular operation (online).

Paper LED (Orange)

- Lights when roll paper is running low or is out.
- Off when there is a sufficient amount of roll paper remaining.
- Flashes when a self-test is in progress or during a macro execution standby state.

Slip LED (Green)

- Lights during printing on slip paper.
- Flashes during slip insertion waiting and slip removal waiting.
- Goes out 2 seconds after slip removal.

Feed button

Pressing this button once feeds paper by one line. Holding this button down feeds paper continuously.

Release button

Pressing this button releases inserted slip paper.

NOTE

Enabling/disabling of the Feed and Release buttons can be selected by a command. If the command is set to disable these buttons, they do not function.

Offline

The printer automatically goes offline under the following conditions:

- During power on (including resetting with the interface) until the printer is ready
- During the self-test
- While roll paper is fed using the Feed button
- When the printer stops printing due to a paper-end (if an empty paper supply is detected by the roll paper end sensor or if the driver has been set to stop printing when a roll paper near-end is detected)
- During a macro execution standby state
- When a temporary abnormality occurs in the power supply voltage
- When an error has occurred

Connectors

All cables are connected to the connector panel on the lower rear of the printer.

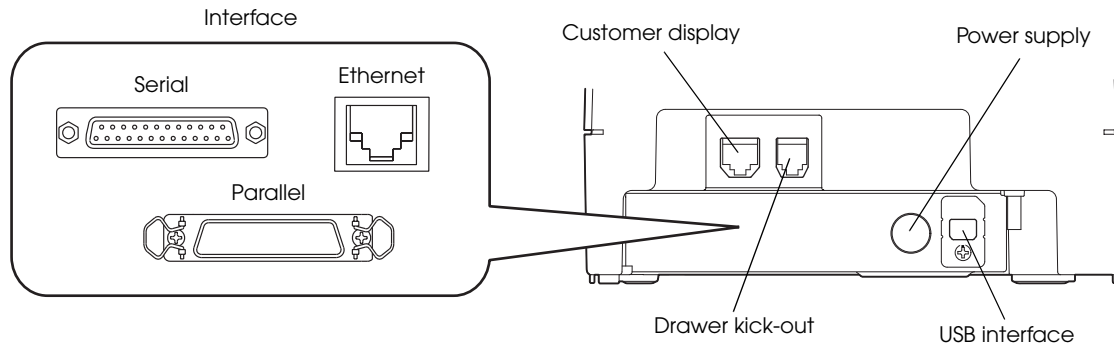

- **Interface connector:** Connects the printer with the host computer interface. The interface type differs depending on the model.
- **Customer display connector:** Connects the customer display (DM-D series).
- **Drawer kick-out connector:** Connects the cash drawer.
- **Power supply connector:** Connects the power supply unit.
- **USB interface connector:** Connects the printer with the host computer via the USB interface. Only the serial/parallel interface models have this built-in USB interface as a standard feature.

NOTE

For details on how to connect the interface connector, power supply connector, and drawer kick-out connector, see ["Connecting the Printer to the Host Computer" on page 53](#), ["Connecting the Power Supply Unit \(PS-180\)" on page 62](#), and ["Connecting the Cash Drawer" on page 71](#).



Error Status

When an error occurs, the printer stops operating, goes offline, and the Error LED flashes.

There are three possible error types: automatically recoverable errors, recoverable errors, and unrecoverable errors.



Automatically Recoverable Errors



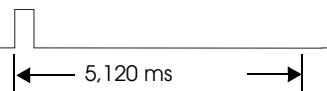

Printing is no longer possible when automatically recoverable errors occur. They can be recovered easily, as described below.

Error	Error description	Error LED flash code 	Recovery measure
Print head temperature error	A high temperature outside the head drive operating range was detected.		Recovers automatically when the print head cools.

Recoverable Errors

Printing is no longer possible when recoverable errors occur. They can be recovered easily by turning the power off and then on again or sending an error recovery command from the driver after eliminating the cause of the error.

Error	Error description	Error LED flash code 	Recovery measure
Autocutter error	Autocutter does not work correctly.		Remove the jammed paper or foreign matter in the printer, close the roll paper cover, send the error recovery command, or turn the power off and on to recover.
Carriage detection error in endorsement printing	The carriage is malfunctioning due to a paper jam, or the slip removal cannot be detected.		

Error	Error description	Error LED flash code 	Recovery measure
Slip ejection error	The slip is not ejected after feeding a specified amount of paper.		Send the error recovery command or turn the power off and on to recover.
Mechanical operation error	The position of the platen/roller open and close mechanism cannot be detected.		
Roll paper cover open error	The roll paper cover was opened during printing.		Close the roll paper cover, and then send the error recovery command or turn the power off and on to recover.
Receipt unit open error*	The receipt unit was opened during printing.		

*: Occurs only when memory switch 8-8 is set to ON.

CAUTION





The error recovery command is valid only if a recoverable error (excluding automatically recoverable errors) occurs.



Unrecoverable Errors

Printing is no longer possible when unrecoverable errors occur. The printer must be repaired.

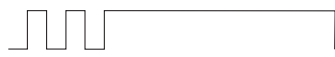
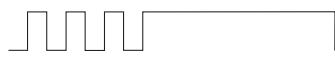

Turn off the power immediately when unrecoverable errors occur.

Error	Error description	Error LED flash code 
R/W error in memory or gate array	After R/W checking, the printer does not work correctly.	
High voltage error	The power supply voltage is extremely high.	
Low voltage error	The power supply voltage is extremely low.	
CPU execution error	The CPU is executing an incorrect address.	

Error	Error description	Error LED flash code 
Interface board error*	The interface board is not connected.	
Circuit error	A circuit error is detected.	

*: This error occurs when the interface board is not connected, DIP switch 2-2 is set to On, and the interface mode is set to UB/built-in USB automatic selection or fixed to UB with the customized value.

NV Memory (Non-Volatile Memory)

The printer's NV memory stores data even after the printer power is turned off. NV memory contains the following memory areas for the user:

- NV graphics memory
- User NV memory
- Memory switches
- Receipt Enhancement (R/E)
- User-defined page
- Maintenance counter

CAUTION

As a guide when you program applications, NV memory should be rewritten 10 or fewer times a day.

NV Graphics Memory

Graphics, such as shop logos to be printed on receipts, can be stored. Even with a serial interface model whose communication speed is low, high speed graphic printing is possible.

Use the TM-H6000IV Utility to register graphics. You can also print and confirm the registered graphics in the TM-H6000IV Utility or NV graphics memory print mode.

NOTE

- For detailed information about the TM-H6000IV Utility, see the TM-H6000IV Utility User's Manual.
- For information about how to use the NV graphics memory print mode, see "[NV Graphics Print Mode](#)" on page 90.

User NV Memory

You can store and read text data for multiple purposes, such as for storing a note including customizing or maintenance information of the printer.

Use ESC/POS commands to store and read the text data.

NOTE

For information about ESC/POS commands, see the ESC/POS Application Programming Guide.

Memory Switches

With the memory switches, which are software switches for the printer, you can configure various settings of the printer.

For information about the memory switches see ["Setting the Memory Switches/Receipt Enhancement" on page 65](#).

R/E (Receipt Enhancement)

Graphics, such as shop logos, can be printed on top or bottom of receipts by setting R/E.

For information about R/E, see ["Setting the Memory Switches/Receipt Enhancement" on page 65](#).

User-defined Page

You can store character data in the user-defined page (character code table: pages 254 and 255) so that you can also print characters not resident in the printer.

Maintenance Counter

With this function, printer information, such as the number of lines printed, the number of MICR readings, the number of autocuts, and printer operation time after the printer starts working, is automatically stored in NV memory. You can read or reset the information with the TM-H6000IV Utility, the Status API of the APD, or OPOS ADK to use it for periodical checks or part replacement.

Product Specifications

Printing method	Receipt	Thermal line printing
	Slip/Endorsement	9-pin serial impact dot matrix
Cutting method		Partial cut (cutting with one point in left edge left uncut)
MICR reader (factory option)		Magnetic bias
Interfaces		Serial (RS-232), Parallel (IEEE 1284), USB (2.0 Full-speed), Ethernet (10BASE-T/100BASE-TX), Wireless LAN (IEEE 802.11b)
Buffers	Receive buffer	4 KB/45 bytes (selectable using DIP switch 1-2)
	Download buffer	For receipt: 12 KB For slip: 3 KB
	NV graphics data	384 KB (initial setting)
	User NV memory	1 KB (initial setting)
Bar code/two-dimensional symbol printing		UPC-A, UPC-E, JAN 8 (EAN 8), JAN 13 (EAN 13), CODE 39, ITF, CODABAR, CODE 93, CODE 128, GS1-128, GS1 DataBar Omnidirectional, GS1 DataBar Truncated, GS1 DataBar Stacked, GS1 DataBar Stacked Omnidirectional, GS1 DataBar Limited, GS1 DataBar Expanded, GS1 DataBar Expanded Stacked, PDF417, QR CODE, MaxiCode, Composite Symbology
Ink ribbon cartridge		Slip: ERC-32 Endorsement: ERC-43
Supplied voltage		DC 24 V \pm 7%
Overall dimensions (H x W x D)		181 x 160 x 278 mm {7.13 x 6.30 x 10.94"}
Weight (mass)*		Approx. 4.0 kg {8.82 lb}

*: For the standard model (with MICR reader and E/P)

Printing Specifications

Slip printing

Printing method		Serial impact dot matrix
Head wire configuration		9-pin vertical line, wire pitch approximately 0.353 mm {1/72"}
Printing direction		Bidirectional, minimum distance printing
Printing speed*	Front	Approx. 5.7 lps (printing 40 columns per line with 17.8 cpi)
	Endorsement	Approx. 4.0 lps (printing 40 columns per line with 21.2 cpi)
Characters per line	Front	Font A (initial setting): 45 Font B: 60
	Endorsement	Font A: 25 Font B: 33 Endorsement font (initial setting): 40
Character dot spacing	Front	Font A (initial setting): 1 dot Font B: 2 half dots
	Endorsement	Font A: 1 dot Font B: 2 half dots Endorsement font (initial setting): 1 dot

lps: lines per second

cpi: characters per inch

*: when the head energizing time is set to normal mode.

NOTE

Printing speed may be slower, depending on such items as the data transmission speed.

Receipt printing

	80 mm {3.15"} width paper printing	58 mm {2.28"} width paper printing
Printing method	Thermal line printing	
Dot density	180 × 180 dpi	
Printing direction	Unidirectional with friction feed	
Maximum print speed* ¹	300 mm/s {11.81"/s}	
Printing width	72.0 mm (2.83"), 512 dots	50.8 mm (2.0"), 360 dots
Characters per line	Font A (initial setting): 42 Font B: 56	Font A (initial setting): 30 Font B: 40
Character spacing* ²	Font A (initial setting): 0.28 mm (2 dots) Font B: 0.28 mm (2 dots)	
Paper feed speed	Approx. 200 mm/s {7.87"/s} (during continuous printing)	
Line spacing* ²	Approx. 4.23 mm {1/6"}	

dpi: dots per inch

*1: When the printer prints with the standard print density level at 24V and 25°C {77°F}.

*2: Initial setting. Programmable by commands.

CAUTION

- When changing the paper width, you need to install the optional 58 mm paper guide (PG-58II) and to change the setting for the paper width with the customized value. To change the paper width, see "[Changing the Paper Width](#)" on page 44.
- Because some parts of the print head and the autocutter contact the platen and they may become worn out in 58 mm printing, once you change the paper width from 80 mm to 58 mm, you cannot change it back to 80 mm.

NOTE

Printing speed may be slower, depending on such items as the data transmission speed.

Character Specifications

Slip printing

Number of characters	Alphanumeric characters: 95 Extended graphics: 128 × 12 pages (including user-defined page) International characters: 37 character types
Character structure	Font A: 5 × 9 Font B: 7 × 9 Endorsement font: 5 × 7
Character size	Font A: 1.56 × 3.11 mm Font B: 1.24 × 3.11 mm Endorsement font: 1.09 × 2.41 mm

Receipt printing

Number of characters	Alphanumeric characters: 95 Extended graphics: 128 × 11 pages (including user-defined page) International characters: 37 character types	
Character structure	Font A: 12 × 24 (including 2-dot horizontal spacing) Font B: 9 × 17 (including 2-dot horizontal spacing)	
Character size	Font A	Standard: 1.41 × 3.39 mm Double-height: 1.41 × 6.77 mm Double-width: 2.82 × 3.39 mm Double-width, double-height: 2.82 × 6.77 mm
	Font B	Standard: 0.99 × 2.40 mm Double-height: 0.99 × 4.80 mm Double-width: 1.98 × 2.40 mm Double-width, double-height: 1.98 × 4.80 mm

Note:

1. Space between characters is not included.
2. Characters can be scaled up to 64 times as large as the standard size.

Paper Specifications

Slip printing

Types	Normal paper, pressure sensitive paper, carbon copy paper
Form	Cut sheet
Size (W × L)	68 to 230 mm × 68 to 297 mm {2.68 to 9.06" × 2.68 to 11.69"}
Thickness	Normal paper (single- ply)
	0.09 to 0.22 mm {0.0035 to 0.0087"}
	Copy paper (front)
	Backing paper: 0.07 to 0.12 mm {0.0028 to 0.0047"} Copy paper, original paper: 0.04 to 0.07 mm {0.0016 to 0.0028"} Carbon copy paper: Approx. 0.035 mm {0.0014"} Total thickness: 0.09 to 0.47 mm {0.0035 to 0.0185"} However, total number of sheets must be 4 or fewer.
	Copy paper (endorsement)
	Backing paper: 0.07 to 0.12 mm {0.0028 to 0.0047"} Copy paper, original paper: 0.04 to 0.07 mm {0.0016 to 0.0028"} Copy carbon paper: Approx. 0.035 mm {0.0014"} Total thickness: 0.09 to 0.31 mm {0.0035 to 0.0122"} However, total number of sheets must be 3 or fewer.

CAUTION

- Copy capability is greatly influenced by the ambient temperature, so printing must be performed under the conditions described below.

	Number of copies	Total thickness	Ambient temperature
Copy paper (front)	Original + 3 copies	0.31 mm or less	10 to 40°C {50 to 104°F}
	Original + 2 copies	0.31 mm or less	5 to 45°C {41 to 113°F}
	Original + 2 copies	0.47 mm or less	10 to 40°C {50 to 104°F}
Copy paper (endorsement)	Original + 2 copies	0.31 mm or less	10 to 40°C {50 to 104°F}

CAUTION

- The slip paper must be flat, without curls or wrinkles, especially at the top edges.
- When using slip paper with a glued area, choose it carefully, since paper feeding is affected by gluing conditions, such as position and dimension.

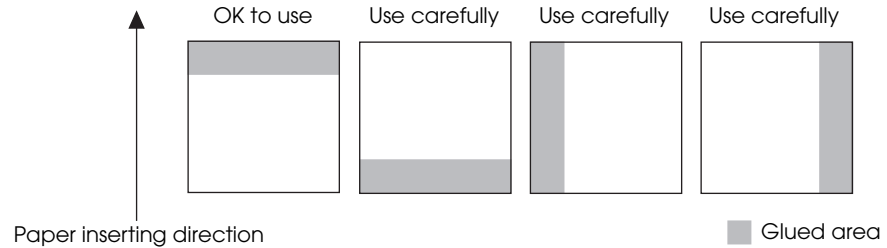

- Use thinner paper (N30 or equivalent) between the top and bottom sheets of multi-ply paper. If thick paper is used, the copy capability is lowered.
- Do not use paper that has holes, or is translucent at the BOF sensor position.
- Do not use paper that has holes or dark positions with low reflection (less than 40% reflection) on the front at the TOF sensor position.

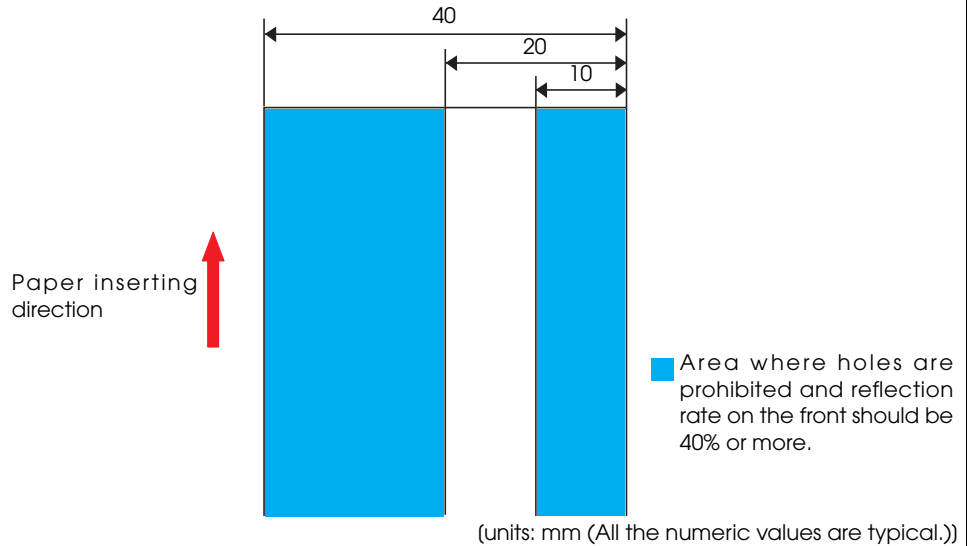

- Do not use paper that has holes or dark positions with low reflection (less than 40% reflection) on the back at the validation sensor (only for the validation models).

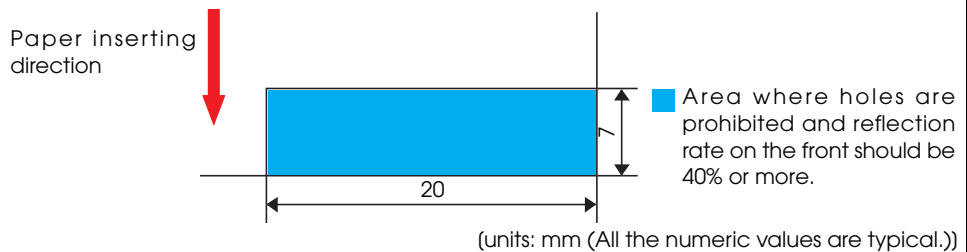

Receipt printing

	80 mm {3.15"} width paper printing	58 mm {2.28"} width paper printing	
Type	Thermal paper		
Form	Roll paper		
Size	Roll paper diameter	83 mm {3.27"} maximum	
	Roll paper spool	Inside: 12 mm {0.47"}, Outside: 18 mm {0.71"}	
	Roll width when taken up	80 + 0.5/-1.0 mm	58 + 0.5/-1.0 mm
	Paper width	79.5 ± 0.5 mm	57.5 ± 0.5 mm
Specified roll paper type	NTP080-80	NTP058-80	

CAUTION

- Paper must not be pasted to the roll paper spool.
- For the best print quality for each paper type, it is recommended to test the print density. (See "[Setting the Memory Switches/Receipt Enhancement](#)" on page 65.)

Printable Area

Slip (front) printing

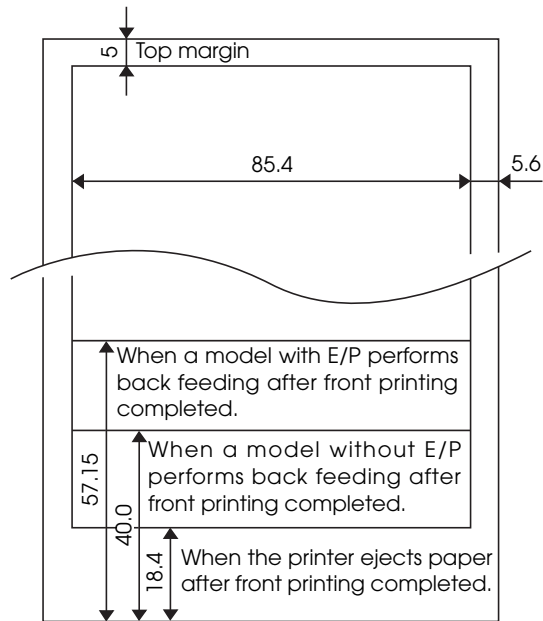

(units: mm (All the numeric values are typical.))

Slip (endorsement) printing

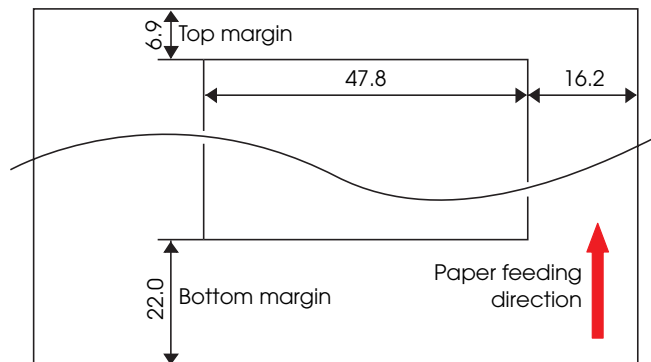

(units: mm (All the numeric values are typical.))

Slip (validation) printing

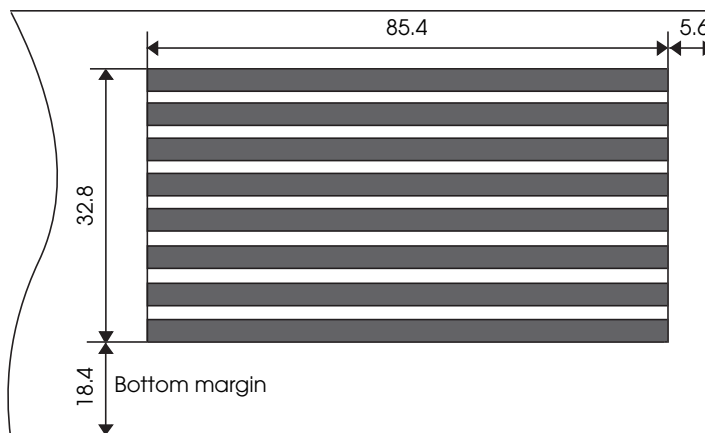

(units: mm (All the numeric values are typical.))

Receipt printing (80 mm paper width)

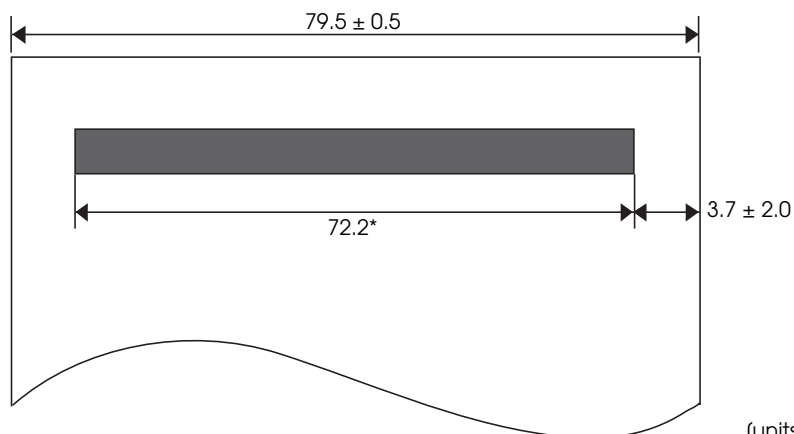

(units: mm (*: typical))

CAUTION

- In 2-divided energizing, the print position within the printable area of the thermal elements for dots 1 to 256 and 257 to 512 is shifted approximately 0.07 mm {0.0028"} as shown in the figure below.



- In 4-divided energizing, the print position within the printable area of the thermal elements for dots 1 to 128, 129 to 256, 257 to 384, and 385 to 512 is shifted approximately 0.04 mm {0.0016"} as shown in the figure below.

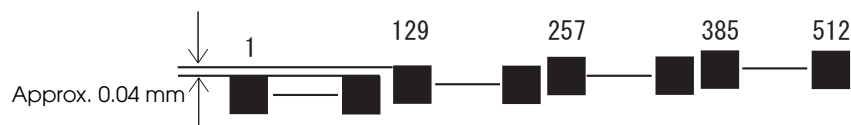

Receipt printing (58 mm paper width)

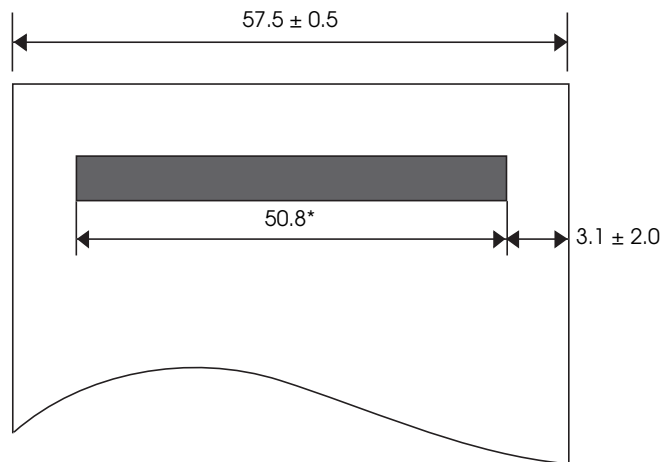

(units: mm (*: typical))

Printing and Cutting Positions

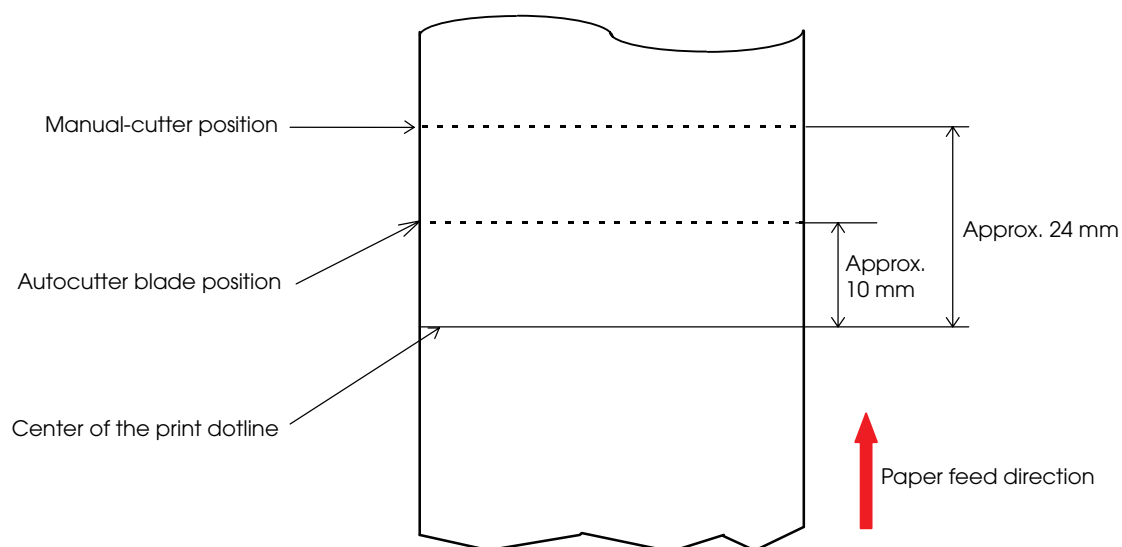

CAUTION

The values above may vary slightly as a result of paper slack or variations in the paper. Take this into account when setting the cutting position of the autocutter.

Ribbon Cassette

Model	Slip printing (front): ERC-32 Endorsement printing: ERC-43	
Color	Black	
Life*	ERC-32	4,000,000 characters
	ERC-43	3,000,000 characters

*: at 25°C {77°F} with continuous printing

MICR Reader (Factory-Installed Option)

Reading method	Magnetic bias
Supported fonts	E13B, CMC7 (Alphabets are not supported.)
Recognition rate*	Recognition rate: 99% or more Recognition error rate: 0.1% or less

*: When using ANSI/ISO specified paper at 25°C {77°F}

Recognition rate (%)=

{Total number of checks-(number of checks misread or not recognized)}/Total number of checks × 100

CAUTION

For reading MICR characters, paper length must be 120 mm {4.72"} or more.

Electrical Characteristics

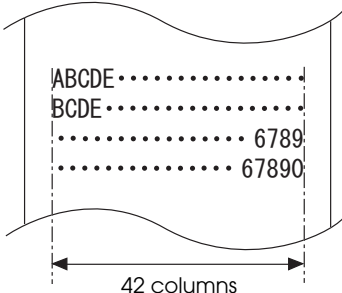
Supply voltage		DC 24V ± 7% Ripple voltage: 300 mVpp or less (for models with MICR reader)			
Current consumption (when using the PS-180 at 24V)	Standby	Mean: Approximately 0.1 A			
	Operating	<table border="1"> <tr> <td>Slip printing</td> <td>Mean: Approximately 1.7 A</td> </tr> <tr> <td>Receipt printing</td> <td>Mean: Approximately 1.8 A</td> </tr> </table> <p>Note: When print ratio is approximately 18%</p> <ul style="list-style-type: none"> • Continuous printing for 50 lines (repeating 20H-7FH) <ul style="list-style-type: none"> * Font A, 42 columns, ASCII character • 5 line feeding • Autocutting 	Slip printing	Mean: Approximately 1.7 A	Receipt printing
Slip printing	Mean: Approximately 1.7 A				
Receipt printing	Mean: Approximately 1.8 A				

CAUTION

If printing is continuously performed with a high ratio, the overcurrent protection may be activated and result in uneven print density or a low voltage error. Therefore, the printing length must not exceed the following values when printing with high print ratio.

Print ratio: Number of dots being energized per one dot line/Total number of dots per one dot line (512 dots)

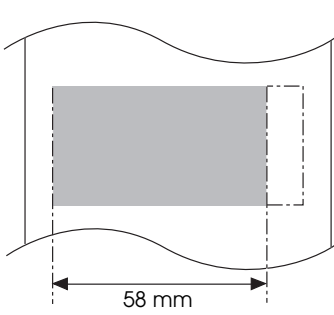
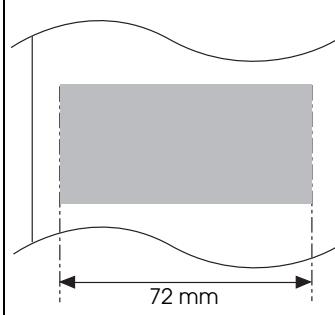
Print ratio	80%	100%
Print example		
Print length	30 mm	20 mm

Reliability

Life	Slip printer section/ Endorsement printer section	Number of carriage driving times	1,200,000 times for each section
		Number of paper feeds	Total for the sections: 27,000,000 lines
		Print head	200 million characters (when printing with Font B only)
	Receipt printer section	Printer mechanism	20,000,000 lines (when repeatedly printing 10 lines with 4.23 mm line spacing and feeding 5 lines)
		Print head	150 million pulses, 150 km
		Autocutter	2,000,000 cuts (when using the specified original paper types, PD150R or PD160R)
	MICR reader mechanism (factory-installed option)		240,000 passes (for US personal checks)
MTBF	Slip printer section/ Endorsement printer section		180,000 hours
	Receipt printer section		360,000 hours
MCBF	Slip printer section/ Endorsement printer section	Number of carriage driving times	29,000,000 times for each section
		Number of paper feeds	Total for the sections: 65,000,000 lines
	Receipt printer section		96,000,000 lines

Environmental Conditions

Temperature/ Humidity	Operating	5 to 45°C {41 to 113°F}, 10 to 90% RH (See the operating temperature and humidity range below.)
	Storage	-10 to 50°C {14 to 122°F}, 10 to 90% RH (except for paper and ink ribbon cartridges)
		<p>Operating environment range</p> <p>34°C, 90%</p> <p>40°C, 65%</p> <p>45°C, 50%</p> <p>----- Specified original paper: P300, P310, P350</p> <p>———— Specified original paper other than above</p> <p>Relative Humidity (%RH)</p> <p>Ambient temperature [°C]</p>
Acoustic noise (operating, receipt printer section)		<p>Approximately 55 dB (bystander position) (including autocutting operation)</p> <p>Note:</p> <p>The values above are measured in the Epson evaluation condition.</p> <p>Acoustic noise differs depending on the paper used, printing contents, and the setting values, such as print speed or print density.</p>

External Dimensions and Mass

The external dimensions and mass of the standard model (with MICR reader and E/P)

- Height: Approximately 181 mm {7.13"}
- Width: Approximately 160 mm {6.30"}
- Depth: Approximately 278 mm {10.94"} (excluding the connector cover)
- Mass: Approximately 4.0 kg {8.82 lb}

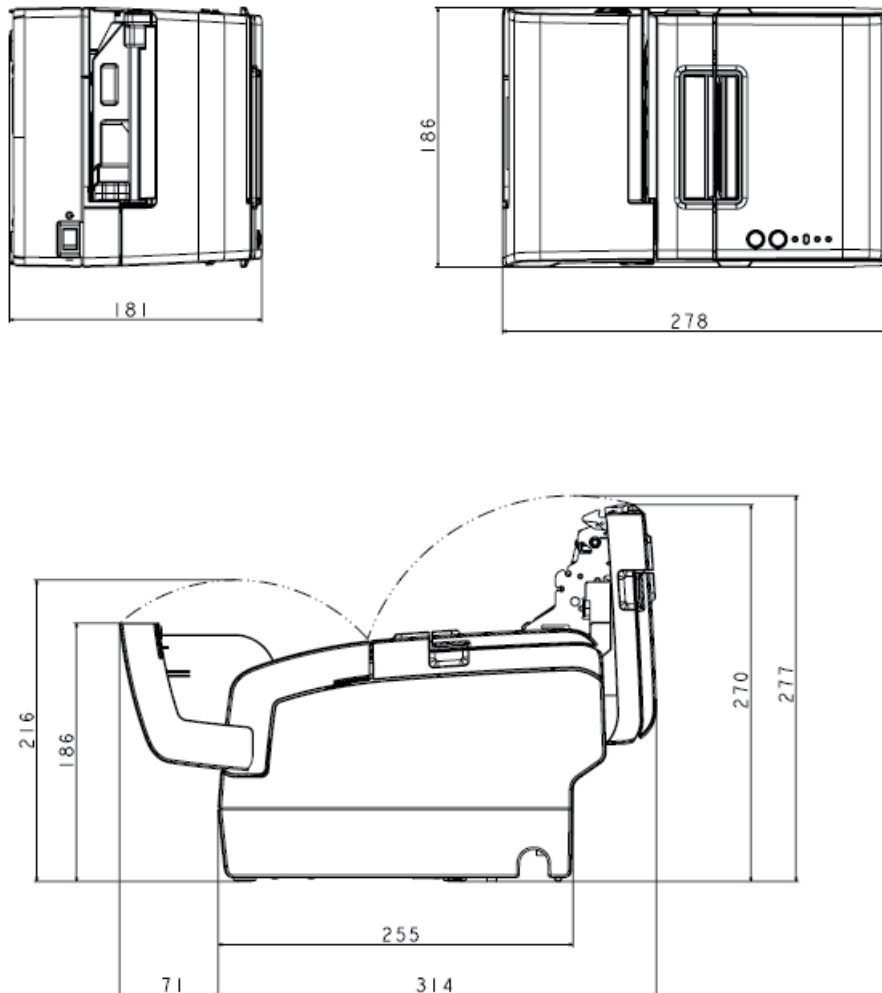

Option Specifications

Power Supply Unit (PS-180)

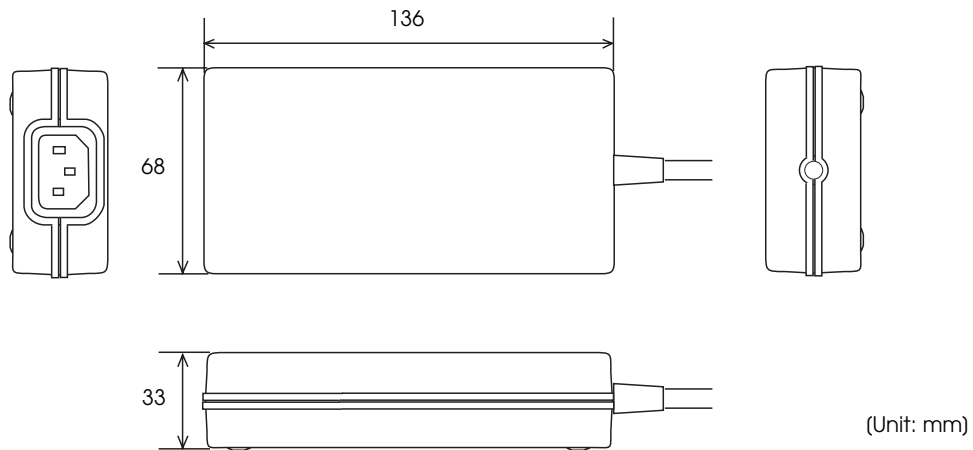

Electric characteristics	Input conditions	Input voltage :AC100V to AC240V
		Frequency : 50-60 Hz
		Input current (rating): 1.3A
	Output conditions	Output voltage (rating): DC24V ± 5%
Output current (rating): 2.1A		
Case specifications	Dimensions (H × W × D)	68 × 136 × 33 mm {2.68 × 5.35 × 1.30"} (excluding projections)
	Weight	Approx. 0.4 kg {14.11 oz} (excluding the AC cable)
	Color	Black (matte)

CAUTION

For Energy Star printers, always use the power supply that came with your printer.

NOTE

For detailed information about the PS-180, see the instruction manual for the PS-180.

Setup

This chapter describes setup and installation of the product and peripherals.

Flow of Setup

This chapter consists of the following sections, along with the setup flow of the product and peripherals.

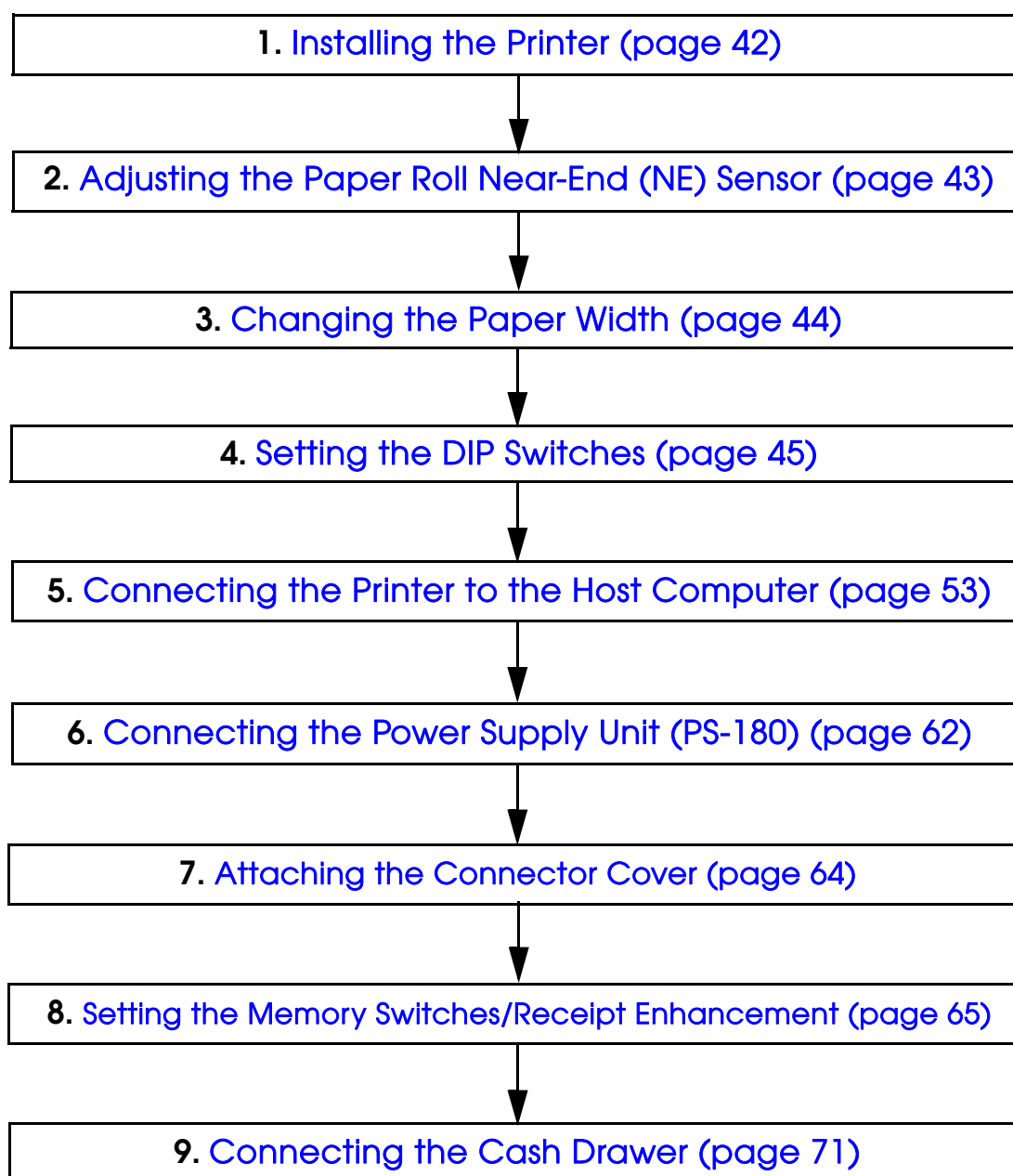

Installing the Printer

Important Notes

- The printer must be installed horizontally on a flat surface (not tilted).
- Do not place the printer in dusty locations.
- Do not knock or strike the printer. This may cause printing errors.
- Do not place any liquids or drinks on the printer case.
- Do not install the printer near any magnetic fields, because this may cause MICR reading errors. Especially when the printer is used near the display device, the user is required to check the recognition rate of the MICR.

Adjusting the Paper Roll Near-End (NE) Sensor

Below are two situations where a roll paper NE sensor adjustment is required.

- To adjust the detection position to suit the diameter of the roll paper core used.
- To adjust the detection position of the remaining amount of roll paper.

CAUTION

- Since roll paper cores vary slightly in shape, depending on paper roll design and manufacturing tolerances, it is impossible to detect the remaining paper exactly.
- Use roll paper with a core inner diameter of 12 mm {0.47"} and outer diameter of 18 mm {0.71"} so that the NE sensor can detect the remaining paper as accurately as possible.

Follow the steps below to adjust the roll paper near-end sensor.

- 1 Open the roll paper cover.
- 2 Loosen the adjustment screw fastening the sensor, and align the upper edge of the positioning plate with the adjustment position.

Adjustment position	Remaining amount of paper (outer diameter)
Upper	Approx. 27 mm {1.06"}
Lower (Initial setting)	Approx. 23 mm {0.91"}

- 3 Tighten the adjustment screw.
- 4 Make sure that the detection lever operates smoothly.

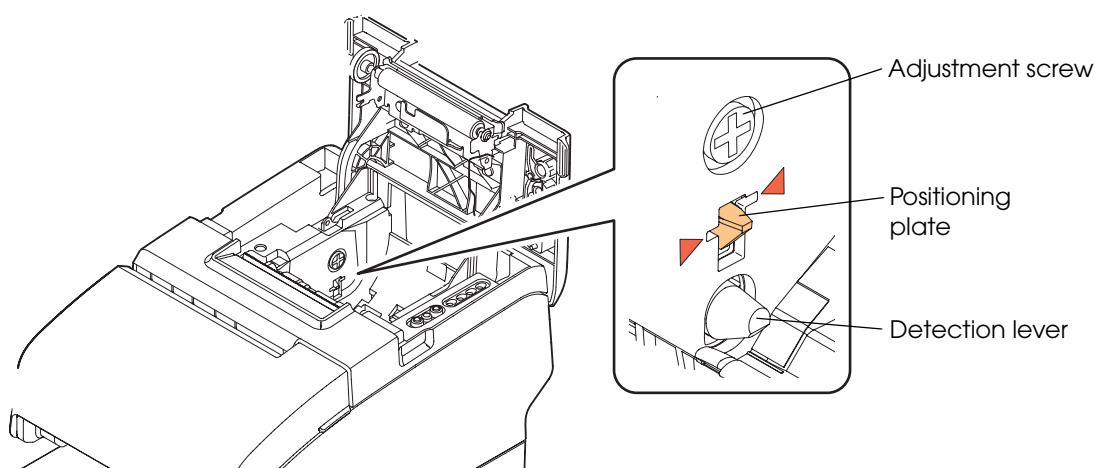

Changing the Paper Width

The printer is initially set to print on 80 mm {3.15"} width paper, but you can change the printer to print on 58 mm {2.28"} width paper by installing the optional roll paper guide.

Follow the steps below to install the roll paper guide.

CAUTION

- Because some parts of the print head and the autocutter contact the platen and they may become worn out in 58 mm printing, once you change the paper width from 80 mm to 58 mm, you cannot change it back to 80 mm.
- When changing the paper width, be sure to change the setting for the paper width with the customized value. To set the customized value, see "[Setting the Memory Switches/Receipt Enhancement](#)" on page 65

- 1 Open the roll paper cover.
- 2 Align 3 projections on the paper guide with the holes in the roll paper holder, and push it until it clicks into place.

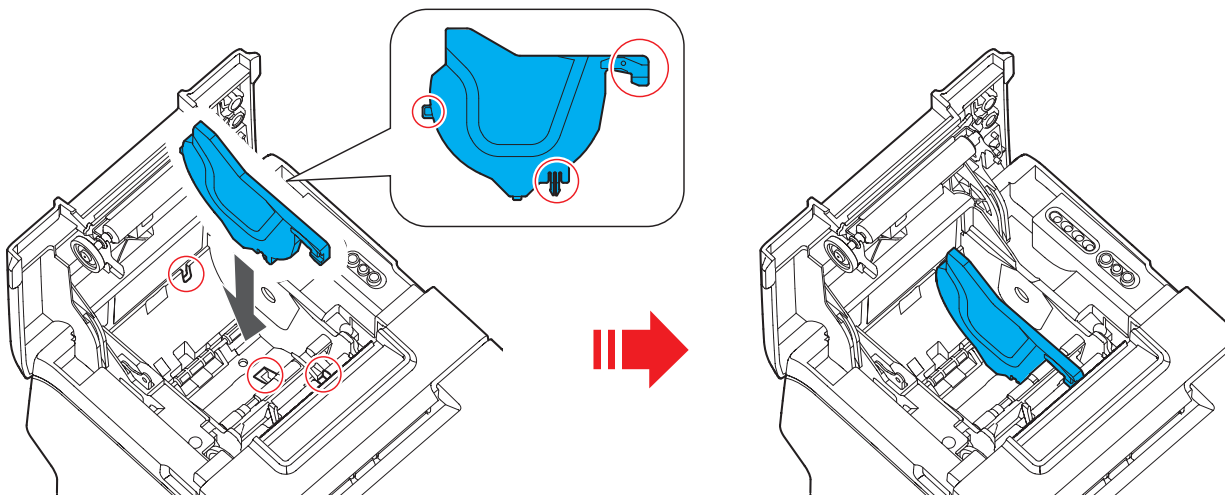

Setting the DIP Switches

On this printer, you can make various settings with DIP switches. Functions of the DIP switches differ depending on the interface.

Setting Procedure

Follow the steps below to change the DIP switch settings.



Before you remove the DIP switch cover, turn the printer off.
Otherwise, a short-circuit may cause the printer to malfunction.



DIP switch settings are enabled only when the power is turned on or the printer is reset via the interface. If the settings are changed after that, the functions will not change.

- 1** Make sure the power supply for the printer is turned off.
- 2** Unscrew the screw to remove the DIP switch cover from the base of the printer.
- 3** Set the DIP switches, using the tip of a tool, such as a small screwdriver.
- 4** Replace the DIP switch cover, and screw it in place.

For Serial Interface

DIP Switch Bank 1

SW	Function	ON	OFF	Initial setting
1-1	Data reception error	Ignored	Prints "?"	OFF
1-2	Receive buffer capacity	45 bytes	4 KB	OFF
1-3	Handshaking	XON/XOFF	DTR/DSR	OFF
1-4	Word length	7 bits	8 bits	OFF
1-5	Parity check	Yes	No	OFF
1-6	Parity selection	Even	Odd	OFF
1-7	Transmission speed selections	See the "Transmission Speed (DIP Switches 1-7/1-8)" table below.		ON
1-8				OFF

Transmission Speed (DIP Switches 1-7/1-8)

Transmission speed (bps: bits per second)	SW 1-7	SW 1-8
4800	ON	ON
9600	OFF	ON
19200 (initial setting)	ON	OFF
Setting with the memory switch*: 2400, 4800, 9600, 19200, 38400 (initial setting), 57600, 115200	OFF	OFF

bps: bits per second

* When DIP switches 1-7 and 1-8 are set to OFF, the value (initially 38400) can be set to any of the values listed in the lower portion of the row using a command, memory switch setting mode, or the TM-H6000IV Utility. (See "Setting the Memory Switches/Receipt Enhancement" on page 65.)

NOTE

Depending on print conditions, such as print duty, print head temperature, and data transmission speed, print speed is automatically adjusted, which can cause white lines due to intermittent print (the motor sometimes stops). To avoid this, set the transmission speed higher or keep the print speed constant by setting it lower. (See "Setting the Memory Switches/Receipt Enhancement" on page 65.)

DIP Switch Bank 2

SW	Function	ON	OFF	Initial setting
2-1	Handshaking (BUSY condition)	Receive buffer full	<ul style="list-style-type: none"> • Offline • Receive buffer full 	OFF
2-2	Customer display (DM-D) connection	Connected	Not connected	OFF
2-3 ~ 2-4	Selects print density	See "Selecting the Print Density (DIP Switches 2-3/2-4)" on page 51.		OFF
2-5 ~ 2-6	Reserved	Fixed to OFF		OFF
2-7	I/F pin 6 reset signal	Enabled	Disabled	OFF
2-8	IF pin 25 reset signal	Enabled	Disabled	OFF

CAUTION

For DIP switch 2-1 (BUSY condition), see also ["Selecting the BUSY Status"](#) on page 52.

For Parallel Interface

DIP Switch Bank 1

SW	Function	ON	OFF	Initial setting
1-1	Auto line feed	Always enabled	Always disabled	OFF
1-2	Receive buffer capacity	45 bytes	4 KB	OFF
1-3 ~ 1-8	Reserved	Fixed to OFF		OFF

DIP Switch Bank 2

SW	Function	ON	OFF	Initial setting
2-1	Handshaking (BUSY condition)	Receive buffer full	<ul style="list-style-type: none"> • Offline • Receive buffer full 	OFF
2-2	Reserved	Fixed to OFF		OFF
2-3 ~ 2-4	Selects print density	See "Selecting the Print Density (DIP Switches 2-3/2-4)" on page 51.		OFF
2-5 ~ 2-7	Reserved	Fixed to OFF		OFF
2-8	IF pin 31 reset signal	Fixed to ON		ON

CAUTION

For DIP switch 2-1 (BUSY condition), see also ["Selecting the BUSY Status"](#) on page 52.

For Built-in USB Interface

DIP Switch Bank 1

SW	Function	ON	OFF	Factory setting
1-1	Auto line feed	Always enabled	Always disabled	OFF
1-2	Receive buffer capacity	45 bytes	4 KB	OFF
1-3 ~ 1-7	Reserved	Fixed to OFF		OFF
1-8	Setting of USB power-saving function*	Disabled	Enabled	OFF

*: Valid only when the system configuration is set so that the USB driver can support the USB power-saving function.

DIP Switch Bank 2

SW	Function	ON	OFF	Factory setting
2-1	Handshaking (BUSY condition)	Receive buffer full	<ul style="list-style-type: none"> • Offline • Receive buffer full 	OFF
2-2	Customer display (DM-D) connection	Connected	Not connected	OFF
2-3 ~ 2-4	Selects print density	See " Selecting the Print Density (DIP Switches 2-3/2-4) " on page 51.		OFF
2-5 ~ 2-7	Reserved	Fixed to OFF		OFF
2-8	Reserved	Fixed to ON		ON

CAUTION

For DIP switch 2-1 (BUSY condition), see also "[Selecting the BUSY Status](#)" on page 52.

For Ethernet/Wireless LAN Interface

DIP Switch Bank 1

SW	Function	ON	OFF	Initial setting
1-1	Auto line feed	Always enabled	Always disabled	OFF
1-2	Receive buffer capacity	45 bytes	4 KB	OFF
1-3 ~ 1-8	Reserved	Fixed to OFF		OFF

DIP Switch Bank 2

SW	Function	ON	OFF	Initial setting
2-1	Handshaking (BUSY condition)	Receive buffer full	<ul style="list-style-type: none"> • Offline • Receive buffer full 	OFF
2-2	Reserved	Fixed to OFF		OFF
2-3 ~ 2-4	Selects print density	See " Selecting the Print Density (DIP Switches 2-3/2-4) " on page 51.		OFF
2-5 ~ 2-7	Reserved	Fixed to OFF		OFF
2-8	Reserved	Fixed to ON		ON

CAUTION

For DIP switch 2-1 (BUSY condition), see also "[Selecting the BUSY Status](#)" on page 52.

Selecting the Print Density (DIP Switches 2-3/2-4)

Function	SW 2-3	SW 2-4
Print density (standard)	OFF	OFF
Print density (darker than standard)	ON	OFF
Print density (dark)	OFF	ON

Depending on the paper type, it is recommended to set the print density as shown in the table below for the best print quality.

Original Paper Type	Density Level
TF50KS-E, TF60KS-E, PD150R, PD160R, PD190R, P220AGB-1, AF50KS-E, KT48F20, KT55F20, F5041, P350	Standard
P300, P310	Darker than standard

CAUTION

- If the print density is set to "Darker than standard" or "Dark" level, printing speed may be reduced.
- If the print density is set to "Darker than standard" or "Dark" level, paper dust will accumulate on the print head and print may be faint. For information on how to clean the thermal head, see ["Cleaning the Thermal Head" on page 106](#).
- The print density can be set with DIP switches (2-3/2-4) or the customized value. (See ["Setting the Memory Switches/Receipt Enhancement" on page 65](#).) The initial setting of the customized value is "Depends on the DIP switch settings." If the customized value is changed, the value set with the customized value is enabled.

Selecting the BUSY Status

With DIP switch 2-1, you can select conditions for invoking a BUSY state as either of the following:

- When the receive buffer is full
- When the receive buffer is full or the printer is offline

CAUTION

In either case above, the printer enters the BUSY state after power is turned on (including resetting with the interface) and when a self-test is being run.

Printer BUSY Condition and Status of DIP Switch 2-1

Printer status		DIP SW 2-1	
		ON	OFF
Offline	During the period after the power is turned on (including resetting with the interface) to when the printer is ready to receive data.	BUSY	BUSY
	During the self-test.	BUSY	BUSY
	When the cover is open.	—	BUSY
	During paper feed with the Feed button.	—	BUSY
	When the printer stops printing due to a paper-end (when printer has run out of roll paper).	—	BUSY
	When an error has occurred.	—	BUSY
When the receive buffer becomes full.		BUSY	BUSY

CAUTION

If BUSY condition is set to "Receive buffer full," the printer will not become BUSY

- When the cover is open
- When paper is fed by the FEED button
- When printing has stopped for a paper-end
- When an error has occurred

Connecting the Printer to the Host Computer

CAUTION

- Be sure to install the driver before connecting the printer to the host computer.
- The printer uses modular connectors specifically designed for the cash drawer and the customer display. Do not connect an ordinary telephone line to these connectors.

For Serial Interface

Serial interface connection diagram

When this printer and the customer display (DM-D) are connected to a host computer by the serial interface, three connection forms are possible:

- Stand-alone connection
- Pass-through connection
- Y connection

NOTE

The modular cable is connected to the cash drawer and/or the customer display.

Stand-alone connection

This printer is connected to the host computer via the serial port. When a customer display (DM-D) is to be connected, connect it to the host computer via the serial port.

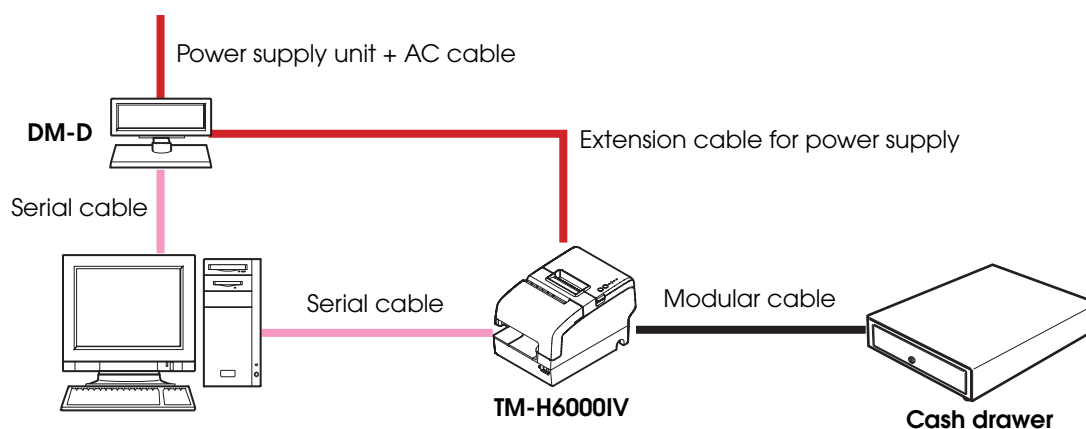

Pass-through connection

This printer is connected to the host computer over the serial interface via a customer display (DM-D).

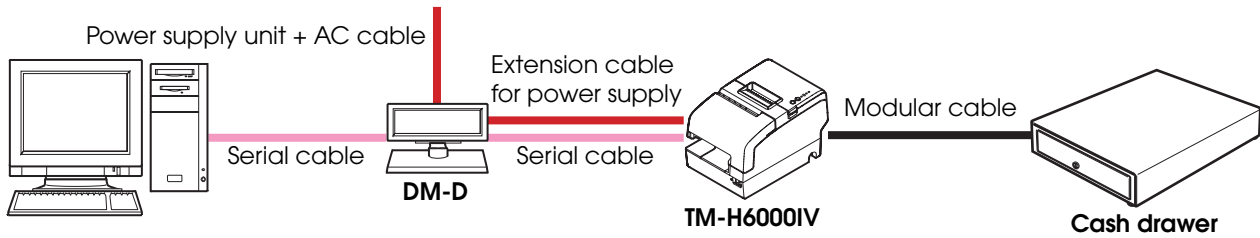

Y connection

This printer is connected to the host computer via the serial port. When a customer display (DM-D) is to be connected, connect it to the printer via the modular cable.

NOTE A mount-type customer display also can be directly connected to the printer.

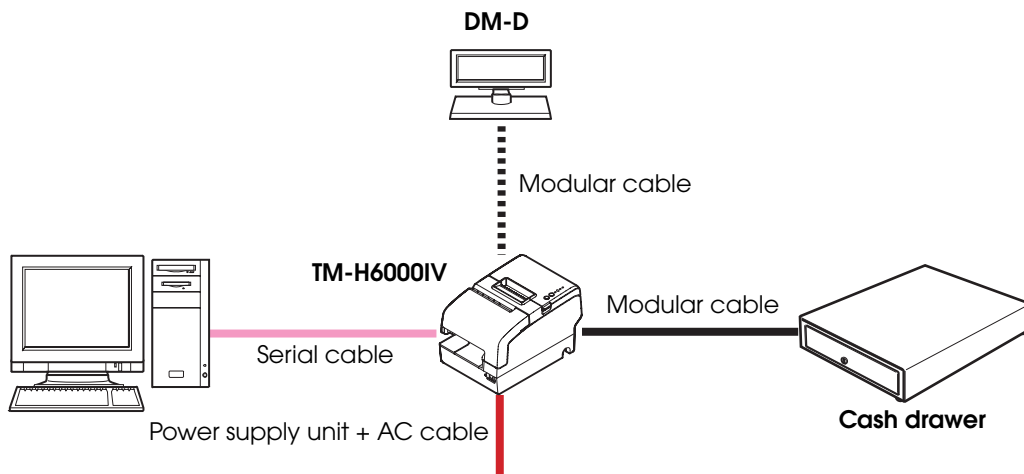

Connecting the serial interface (RS-232) cable



Be sure to turn off the power supply for both the printer and host computer before connecting the cables.



Use a null modem serial cable to connect the printer.

- 1** Insert the interface cable connector firmly into the interface connector on the connector panel.
- 2** When using connectors equipped with screws, tighten the screws to secure the connectors firmly.

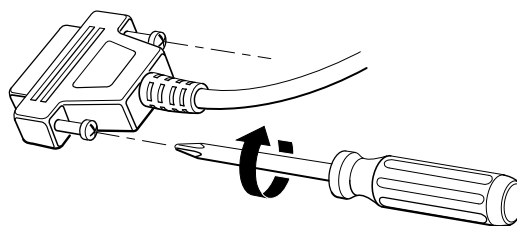

- 3** When using interface cables equipped with a grounding line, attach the ground line to the screw hole marked "FG" on the printer.
- 4** Connect the other end of the interface cable to the host computer.

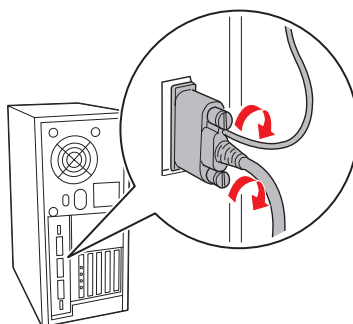

For Parallel Interface

Parallel interface connection diagram

This printer is connected to the host computer via the parallel port. When a customer display (DM-D) is to be connected, connect it to the host computer via the serial port.

NOTE

The modular cable is connected to the cash drawer.

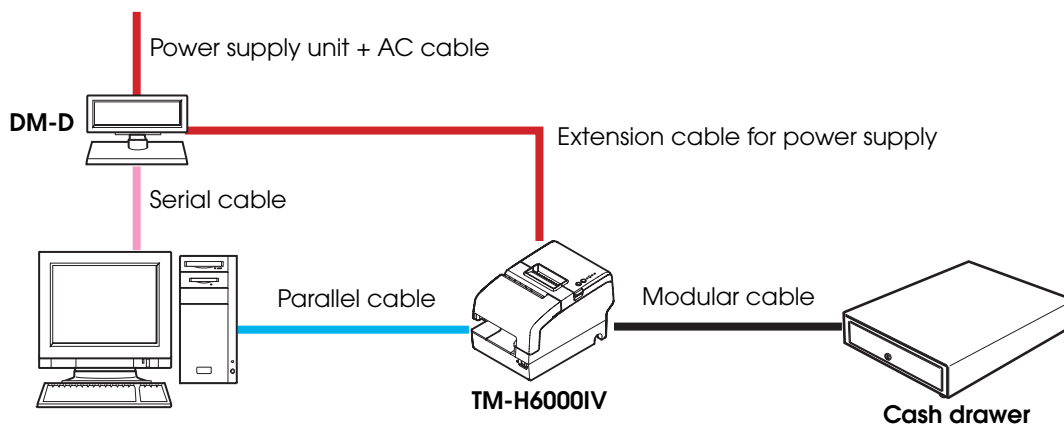

Connecting the parallel interface cable

- 1 Insert the interface cable connector firmly into the interface connector on the connector panel.
- 2 Press down the clips on either side of the connector to lock it in place.
- 3 When using interface cables equipped with a ground line, attach the ground line to the screw hole marked "FG" on the printer.
- 4 Connect the other end of the interface cable to the host computer.

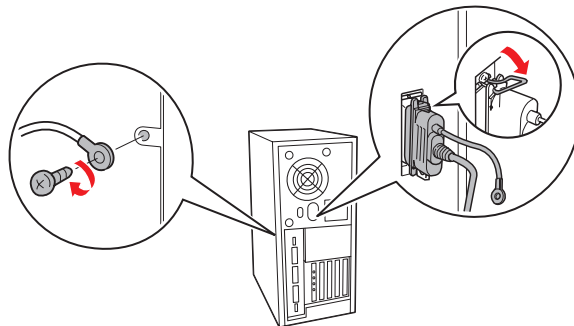

For USB Interface

USB interface connection diagram

When this printer is connected to the host computer by the USB interface, two connection forms are possible, Stand-alone connection or Y connection.

NOTE

The modular cable is connected to the cash drawer and/or the customer display.

Stand-alone connection

This printer is connected to the host computer via the USB port. When a customer display (DM-D) is to be connected, connect it to the host computer via the serial port.

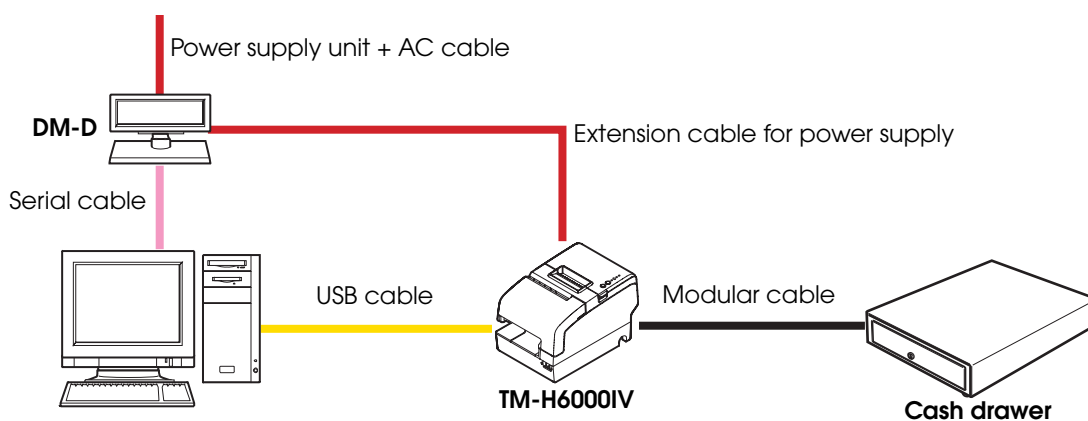

Y connection

This printer is connected to the host computer via the USB port. When a customer display (DM-D) is to be connected, connect it to the printer via the modular cable.

NOTE

A mount-type customer display also can be directly connected to the printer.

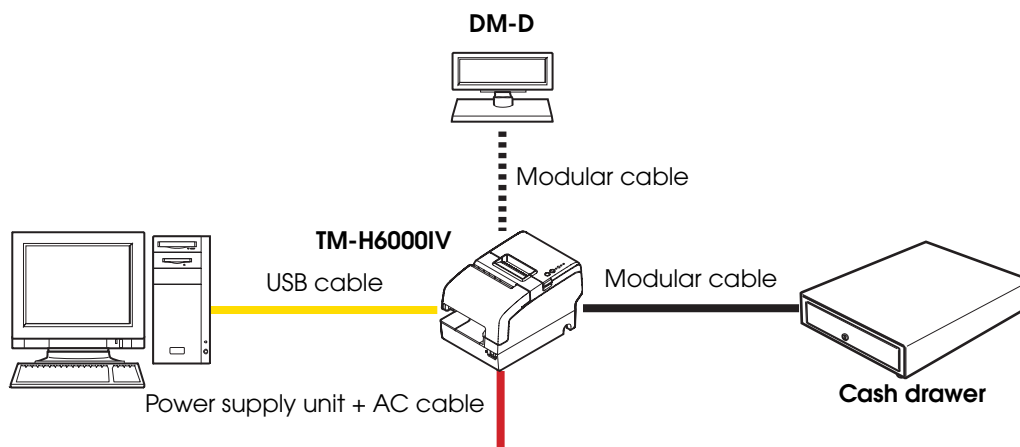

Connecting the USB interface cable

- 1 Put the USB cable through the locking wire saddle.

CAUTION

Putting the USB cable through the locking wire saddle, as shown in the figure below, prevents the cable from coming unplugged.

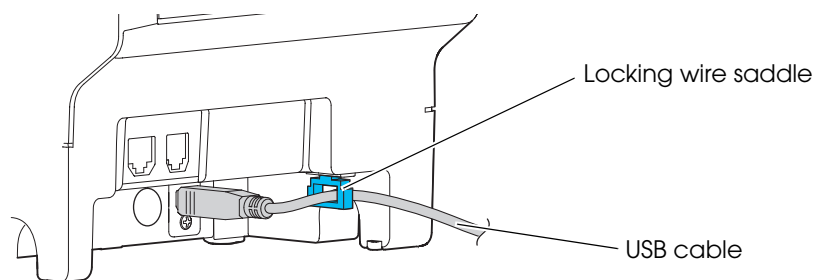

- 2 Connect the USB cable from the host computer to the USB upstream connector.
- 3 Connect the other end of the interface cable to the host computer.

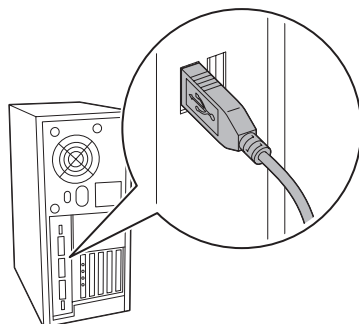

For Ethernet Interface

Connect the printer to a network by a LAN cable via a hub.

Ethernet interface connection diagram

NOTE

The modular cable is connected to the cash drawer.

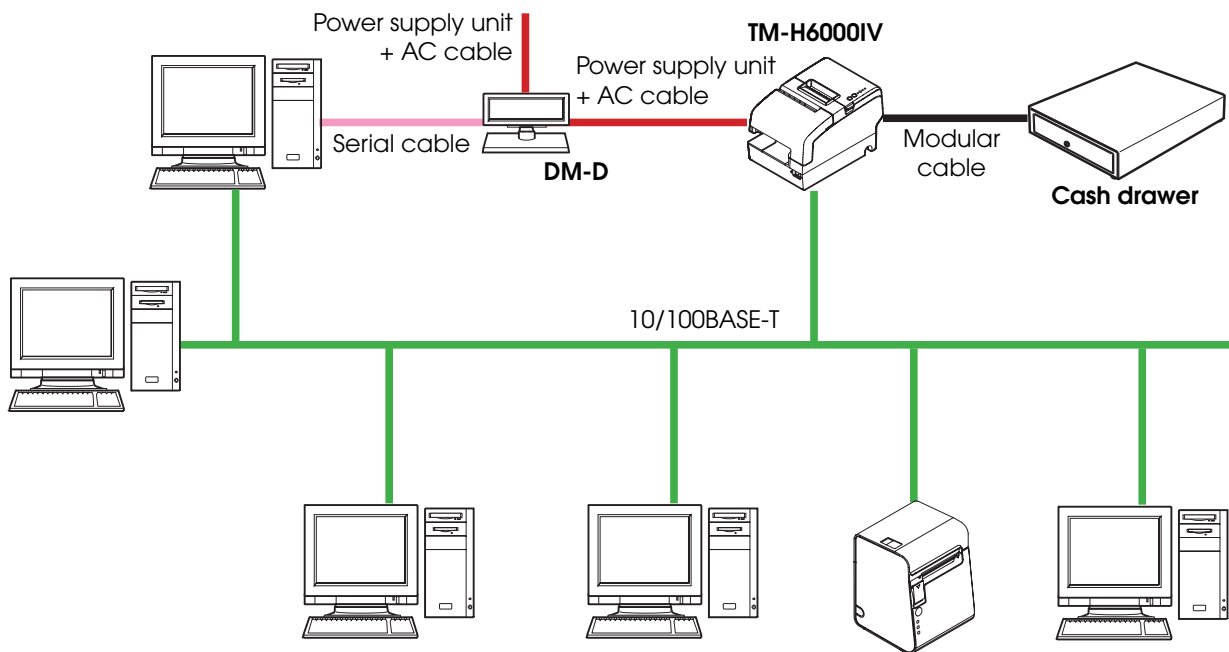

Connecting the Ethernet interface cable



- **When LAN cables are installed outdoors, make sure devices without proper surge protection are cushioned by being connected through devices that do have surge protection.**
Otherwise, the devices can be damaged by lightning.
- **Never attempt to connect the customer display cable, drawer kick-out cable, or a standard telephone line cable to the 10/100BASE-T LAN connector.**

NOTE

To use the Ethernet interface, the IP Address Setup Utility for UB-E02 is required. For detailed information about the setup methods, see the UB-E02 Technical Reference Guide. You can obtain the IP Address Setup Utility for UB-E02 and the UB-E02 Technical Reference Guide from one of the following URLs or ask your dealer:

- For customers in North America, go to the following web site:
<http://www.epsonexpert.com/>
- For customers in other countries, go to the following web site:
<http://www.epson-pos.com/>

Connect a 10/100BASE-T cable to the 10/100BASE-T LAN connector by pressing firmly until the connector clicks into place.

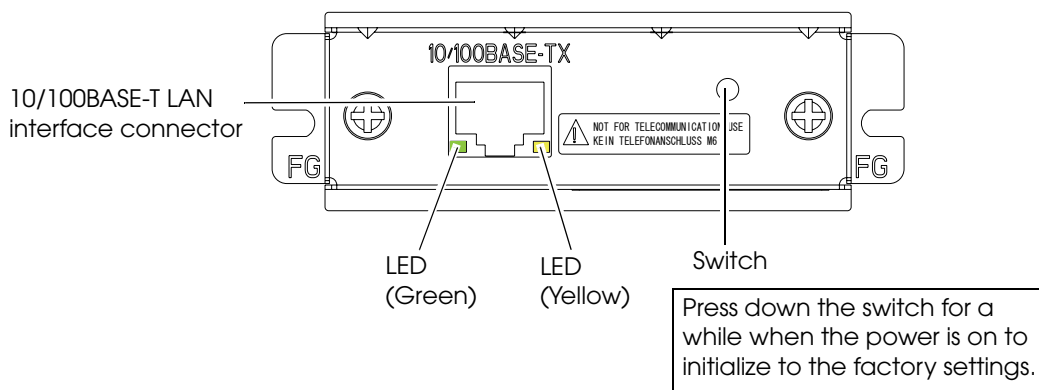

For Wireless LAN Interface

For details on how to set up a wireless LAN interface, see the UB-R02/R03 Technical Reference Guide.

Wireless LAN interface connection diagram

NOTE

- To use the wireless LAN interface, the IP Address Setup Utility for UB-R02/R03 is required. For detailed information about the setup methods, see the UB-R02/R03 Technical Reference Guide. You can obtain the IP Address Setup Utility for UB-R02/R03 and the UB-R02/R03 Technical Reference Guide from one of the following URLs or ask your dealer:
 - * For customers in North America, go to the following web site:
<http://www.epsonexpert.com/>
 - * For customers in other countries, go to the following web site:
<http://www.epson-pos.com/>
- Initial setting of the UB-R02 is ad hoc mode.

Ad hoc mode

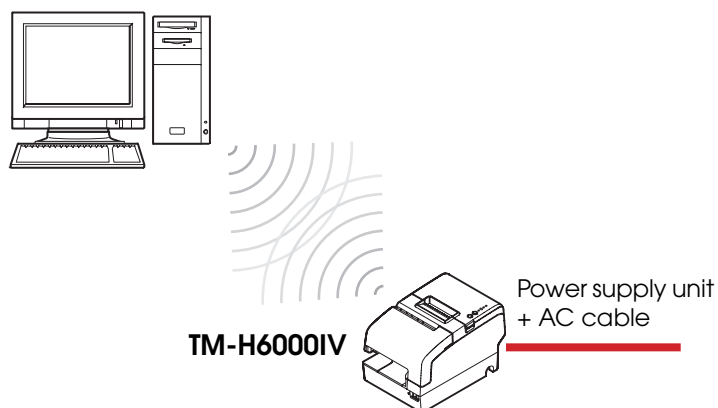

Infrastructure mode

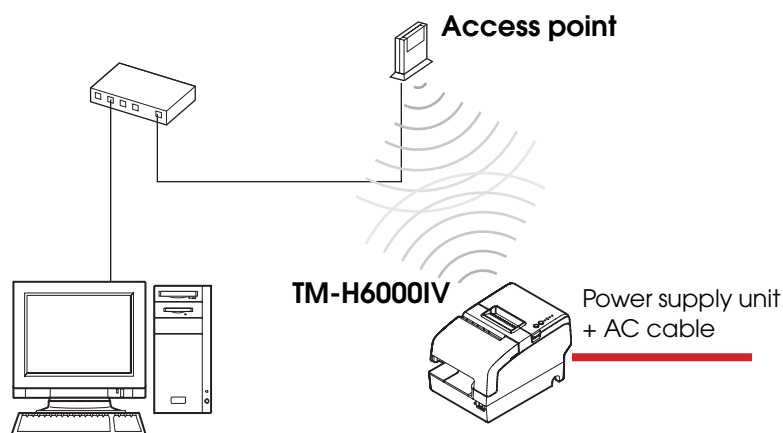

Connecting the Power Supply Unit (PS-180)

Use the PS-180 or an equivalent product as the power supply unit.

Before using the power supply unit, read carefully the user's manual enclosed with it.



WARNING

- **Always use the EPSON PS-180 or an equivalent product as the power supply unit.** Using a nonstandard power supply can result in electric shock and fire.
- **Should a fault ever occur in the EPSON PS-180 or equivalent product, immediately turn off the power to the printer and unplug the power supply cable from the wall socket.**

NOTE

For an Energy Star-compliant printer, use only the power supply that came with the printer.

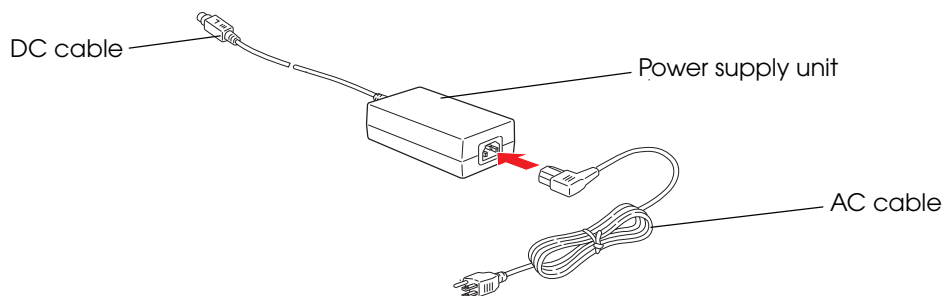

Connecting the Power Supply Unit

- 1** Make sure the printer's power supply is turned off and the AC cable has been unplugged from the wall socket.
- 2** Insert the connector of the DC cable onto the power supply connector.

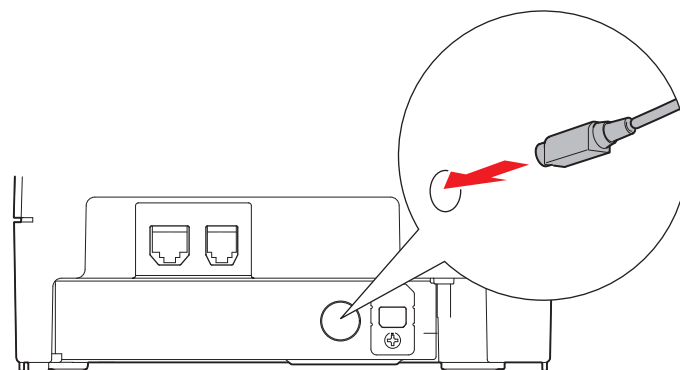

3 Connect the plug of the AC cable to the wall socket.

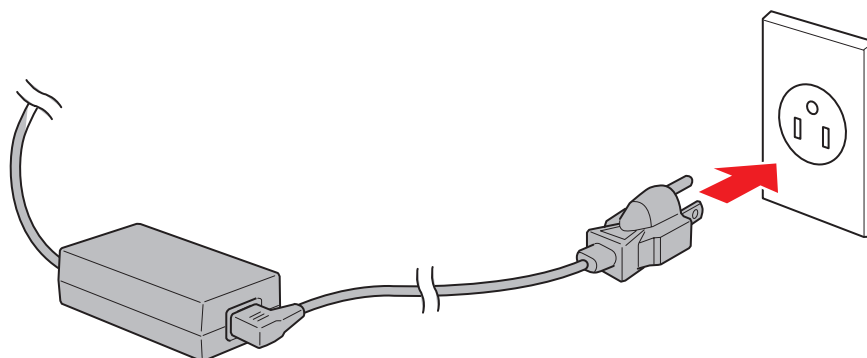

WARNING

- **Be sure to unplug the AC cable from the wall socket whenever connecting or disconnecting the power supply unit to the printer.**
Failure to do so may result in damage to the power supply unit or the printer.
- **Make sure the wall socket power supply satisfies the rated voltage requirements of the power supply unit. Never insert the power supply cable plug into a socket that does not meet the rated voltage requirements of the power supply unit.**
Doing so may result in damage to both the power supply and the printer.

CAUTION

Do not turn on the printer before installing the printer driver.

Attaching the Connector Cover

Follow the steps below to attach the connector cover to protect cables.

- 1** Align 2 projections **A** on the top of the connector cover with holes in the back of the printer.
- 2** Push the connector cover forward so that the projections **B** at the bottom of the printer fit properly in the holes in both sides of the connector cover.

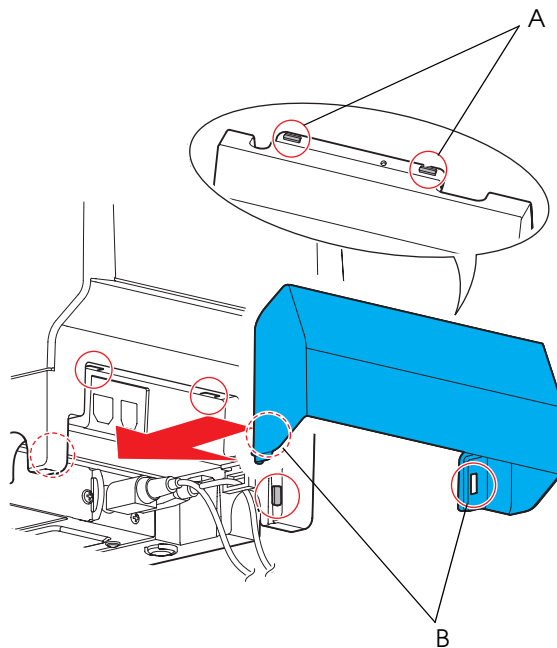

NOTE

To remove the connector cover, push both sides of the cover inward to release the holes in both sides of the cover from the projections at the bottom of the printer.

Setting the Memory Switches/Receipt Enhancement

With the memory switch and R/E (receipt enhancement) function, which are software settings for this printer, you can set the various functions.

For an outline of the functions, see the following section. Use the methods shown in the table below; TM-H6000IV Utility, Memory Switch Setting Mode, or ESC/POS commands, to set the memory switches and R/E functions.

Settings\Setting Methods		TM-H6000IV Utility	Memory Switch Setting Mode	ESC/POS Commands	
Memory Switches	Power on notice		✓	✓	
	Error signal output		✓	✓	
	Slip paper jam detection		✓	✓	
	Receipt unit open during printing		✓	✓	
	Customized Values	User NV memory capacity		✓	✓
		NV graphics memory capacity		✓	✓
		Interface selection		✓	✓
		Number of head energizing parts			✓
		Roll paper width	✓	✓	✓
		Receipt print density	✓	✓	✓
		Receipt print speed	✓	✓	✓
		Command execution during offline	✓	✓	✓
		Power supply unit capacity	✓	✓	✓
		Autocutting at roll paper cover close	✓	✓	✓
	Automatic paper reduction	✓	✓	✓	
	Print density in multi-tone printing	✓	✓	✓	
Transmission speed for serial interface	✓	✓	✓		
Receipt Enhancement	Automatic top logo printing	✓		✓	
	Automatic bottom logo printing	✓		✓	
	Top logo printing at cover close	✓		✓	
	Top logo printing at power on	✓		✓	

NOTE

- For detailed information about the TM-H6000IV Utility, see the TM-H6000IV Utility User's Manual.
- For information about how to use the memory switch setting mode, see "[Memory Switch Setting Mode](#)" on page 93.
- For detailed information about ESC/POS commands, see the ESC/POS Application Programming Guide.

Functions

Power on notice

- Transmits (initial setting)
- Does not transmit

Error signal output

- Enabled (initial setting)
- Disabled

CAUTION

This function is valid only when using the parallel interface.

Slip paper jam detection

- Enabled (initial setting)
- Disabled

Receipt unit open during printing

- Offline (initial setting)
- Recoverable error

User NV memory capacity

- 1 KB (initial setting)
- 64 KB
- 128 KB
- 192 KB

NV graphics memory capacity

- None
- 64 KB
- 128 KB
- 192 KB
- 256 KB
- 320 KB
- 384 KB (initial setting)

Interface selection

Selectable from: automatic selection, fixed to UB interface, or fixed to built-in USB.

NOTE

The TM-H6000IV has dual interfaces: a built-in USB interface and another interface selected by the customer. (The selectable interface is referred to as the "UB" interface.) The tables below describe the modes you can set for the printer to control the dual interfaces.

For models with serial/parallel UB

Interface mode	UB	Built-in USB
Automatic selection (initial setting)	Available	Available
Fixed to UB	Available	Not available
Fixed to built-in USB	Not available	Available

For models with other UB

Interface mode	UB	Built-in USB
Automatic selection	Available	Not available
Fixed to UB (initial setting)	Available	Not available
Fixed to built-in USB	Not available	Available

NOTE
Automatic selection:

The interface of either the UB or built-in USB to which data is transmitted first is selected. Once the interface is selected, the selection is enabled until the power is turned off or the printer is reset.

Number of head energizing parts

- One-part energizing (initial setting)
- Two-part energizing
- Four-part energizing

NOTE

- Usually, the number of head energizing parts does not need to be changed.
- The maximum print speed (300 mm/s) can be performed only when one-part energizing is selected.

Roll paper width

- 80 mm (initial setting)
- 58 mm

CAUTION

- Be sure to install the roll paper guide (model: PG-58II) when you select the 58 mm paper width. (See ["Changing the Paper Width" on page 44.](#))
- Because some parts of the print head and the autocutter contact the platen and they may become worn out in 58 mm printing, once you change the paper width from 80 mm to 58 mm, you cannot change it back to 80 mm.

Receipt print density

Selectable from levels 1 to 13 (70% ~ 130%) (initial setting: level 7)

Depending on the paper type, it is recommended to set the print density as shown in the table below for the best print quality.

Original Paper Type	Density Level
AF50KS-E	4 (85%)
TF50KS-E, P220AGB-1	5 (90%)
P350	6 (95%)
TF60KS-E, PD150R, PD160R, PD190R, KT48F20, KT55F20,F5041	7 (100%)
P300, P310	8 (105%)

CAUTION

- If the print density is set to a darker level, printing speed may be reduced.
- If the print density is set to a darker level, paper dust accumulates on the print head and print may be faint. For information on how to clean the thermal head, see ["Cleaning the Thermal Head" on page 106.](#)
- The print density can be set with DIP switches (2-3/2-4) or the customized value. (See ["Selecting the Print Density \(DIP Switches 2-3/2-4\)" on page 51.](#)) The initial setting of the customized value is "Depends on the DIP switch settings." If the customized value is changed, the value set with the customized value is enabled.

Receipt print speed

Selectable from levels 1 to 13 (Slow ~ Fast) (initial setting: level 13)

NOTE

Depending on print conditions, such as print duty, print head temperature, and data transmission speed, print speed is automatically adjusted, which may cause white lines due to intermittent print (the motor sometimes stops). To avoid this, keep the print speed constant by setting it lower, or set the transmission speed higher for the serial interface. (See "[Transmission Speed \(DIP Switches 1-7/1-8\)](#)" on page 46.)

Command execution during offline

When this function is enabled, you can execute specified commands even if the printer is offline due to specified causes.

- Enabled
- Disabled (initial setting)

NOTE

For the combination of the offline causes and executable commands, see the ESC/POS Application Programming Guide.

Power supply unit capacity

Selectable from levels 1 to 3 (Low ~ High) (initial setting: level 3)

Autocutting at roll paper cover close

- Cuts
- Does not cut (initial setting)

Automatic paper reduction

- Extra upper space reduction: disabled (initial setting) or enabled
- Extra lower space reduction: disabled (initial setting) or enabled
- Line space reduction rate: not reduced (initial setting), 25%, 50%, or 75%
- Line feed reduction rate: not reduced (initial setting), 25%, 50%, or 75%
- Barcode height reduction rate: not reduced (initial setting), 25%, 50%, or 75%

Print density in multi-tone printing

Selectable from levels 1 to 13 (70% ~ 130%) (initial setting: level 7)

Depending on the paper type, it is recommended to set the print density for the best print quality.

Transmission speed for serial interface

When DIP switches 1-7 and 1-8 are set to ON, the value (initially 38400) can be set to 2400, 4800, 9600, 19200, 38400, 57600, or 115200. (See "[Transmission Speed \(DIP Switches 1-7/1-8\)](#)" on page 46.)

NOTE

The transmission speed can be set with DIP switches 1-7 and 1-8 (See "[Transmission Speed \(DIP Switches 1-7/1-8\)](#)" on page 46.) or the customized value. When DIP switches 1-7 and 1-8 are set to OFF, the setting with the customized value is enabled.

Automatic top logo printing

Key code

Selectable from key codes of registered logos

Alignment

- Left
- Center
- Right

Automatic bottom logo printing

Key code

Selectable from key codes of registered logos

Alignment

- Left
- Center
- Right

Top logo printing at cover close

- Enabled (initial setting)
- Disabled

Top logo printing at power on

- Enabled
- Disabled (initial setting)

Connecting the Cash Drawer

Use the cash drawer handled by EPSON or your dealer.

Connecting the Drawer Kick-out Cable



- **Specifications of drawers differ depending on makers or models. When you use a drawer other than specified, make sure its specification meets the following conditions.** Otherwise, devices may be damaged.
 - * The load, such as a drawer kick-out solenoid, must be connected between pins 4 and 2 or pins 4 and 5 of the drawer kick-out connector.
 - * When the drawer open/close signal is used, a switch must be provided between drawer kick-out connector pins 3 and 6.
 - * The resistance of the load, such as a drawer kick-out solenoid, must be $24\ \Omega$ or more or the input current must be 1A or less.
 - * Be sure to use the 24V power output on drawer kick-out connector pin 4 for driving the equipment.
- **Use a shield cable for the drawer connector cable.**
- **Two driver transistors cannot be energized simultaneously.**
- **Leave intervals longer than 4 times the drawer driving pulse when sending it continuously.**
- **Be sure to use the printer power supply (connector pin 4) for the drawer power source.**
- **Do not insert a telephone line into the drawer kick-out connector.**
Doing so may damage the telephone line or printer.
- **Do not connect the USB connector ("B" Plugs of the series B connectors) to the drawer kick-out connector.**
Doing so may damage the printer or the host computer system.

Connect the connector of the drawer kick-out cable to the printer.

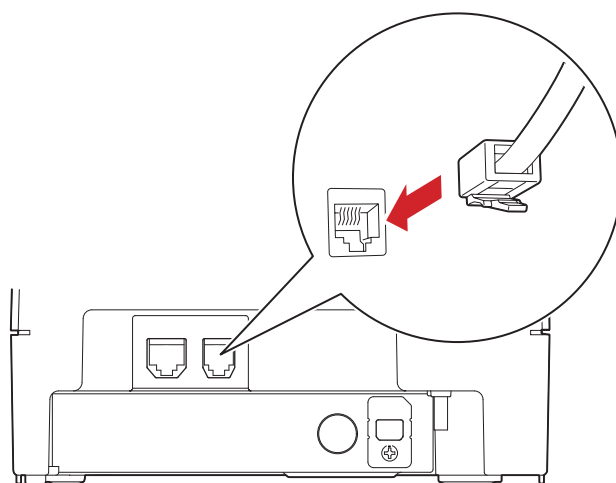

Drawer Connection Circuitry

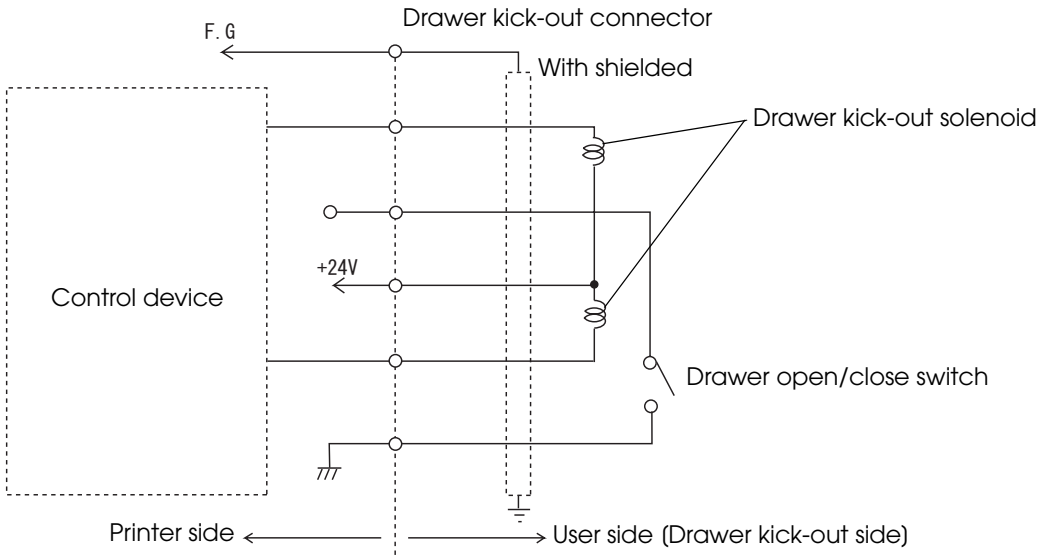

Application Development Information

This chapter describes how to control the printer and gives information useful for printer application development.

How to Control the Printer

Use a driver or ESC/POS commands to control the printer.

Selecting a Driver

Choose one of the drivers listed in "[Printer Drivers](#)" on page 83, depending on the application operating environment.

For information about the driver operating environment, see the installation manual for each driver.

When you develop a new application

- Use APD if you want to print True Type fonts or print many graphics.
- OPOS ADK is recommended for system extensibility. An OPOS driver is provided for various peripherals and it is a POS industry standard now. It enables POS system efficiency, reduction of development cost, and effective use of application assets.

NOTE

You can use all functions, including ones not supported by OPOS ADK or APD, by using ESC/POS commands through your driver. Use the DIRECT I/O function of OPOS ADK, the control A command of APD, or Status API to send ESC/POS commands from each driver. (See "[ESC/POS command functions](#)" on page 74.)

ESC/POS Commands

ESC/POS is the Epson original printer command system. With ESC/POS commands, you can directly control all the TM printer functions, but detailed knowledge of printer specifications or combination of commands is required.

To use ESC/POS commands, you need to agree to a nondisclosure contract first and obtain the ESC/POS Application Programming Guide. Ask your dealer for details.

The ESC/POS command functions are listed below. See the ESC/POS Application Programming Guide for more details.

ESC/POS command functions

Commands	Active sheet	Roll paper	Slip paper		
			Front	Endorsement 40 cpl mode disabled	40 cpl mode enabled
Print commands					
Print and line feed	✓	✓	✓	✓	✓
Print and carriage return	✓	✓	✓	✓	✓
Print and feed paper	✓	✓	✓	✓	✓
Print and reverse feed			✓	✓	✓
Print and feed <i>n</i> lines	✓	✓	✓	✓	✓
Print and reverse feed <i>n</i> lines	✓	✓	✓	✓	✓
Print and eject cut sheet			✓	✓	✓
Print and return to standard mode	✓	✓	✓		
Print data in page mode	✓	✓	✓	✓	✓
Line spacing commands					
Select default line spacing	✓	✓	✓	✓	
Set line spacing	✓	✓	✓	✓	
Character commands					
Select character code table	✓	✓	✓	✓	✓
Select an international character set	✓	✓	✓	✓	✓
Set right-side character spacing	✓	✓	✓	✓	✓
Select print mode(s)	✓	✓	✓	✓	

Turn underline mode on/off	✓	✓	✓	
Turn emphasized mode on/off	✓	✓	✓	
Select character font	✓	✓	✓	
Select character size	✓	✓	✓	
Turn smoothing mode on/off	✓			
Turn double-strike mode on/off	✓	✓	✓	
Turn upside-down print mode on/off	✓	✓	✓	✓
Turn 90° clockwise rotation mode on/off	✓			
Turn white/black reverse print mode on/off	✓			
Select/cancel user-defined character set	✓	✓	✓	
Define user-defined characters	✓	✓	✓	
Cancel user-defined characters	✓	✓	✓	
Cancel print data in page mode	✓	✓		
Printing paper commands				
Select the side of the slip		✓	✓	✓
Feed to the print starting position for the slip		✓	✓	✓
Select paper type(s) for printing	✓	✓	✓	✓
Select paper type(s) for command settings	✓	✓	✓	✓
Set cut sheet wait time	✓	✓	✓	✓
Panel button commands				
Enable/disable panel buttons	✓	✓	✓	✓
Paper sensor commands				
Select paper sensor(s) to stop printing	✓	✓	✓	✓
Select paper sensor(s) to output paper-end signals	✓	✓	✓	✓
Print position commands				
Horizontal tab	✓	✓	✓	✓
Set horizontal tab positions	✓	✓	✓	✓

Set left margin	✓	✓	✓	
Set print area width	✓	✓	✓	✓*1
Select justification	✓	✓	✓	
Set absolute print position	✓	✓	✓	✓
Set relative print position	✓	✓	✓	
Set print position to the beginning of print line	✓	✓	✓	✓
Set print area in page mode	✓	✓		
Select print direction in page mode	✓	✓		
Set absolute vertical print position in page mode	✓	✓		
Set relative vertical print position in page mode	✓	✓		
Bit image commands				
Transmit the NV graphic memory capacity	✓	✓		
Print the graphics data in the print buffer	✓			
Transmit the remaining capacity of the NV graphics memory	✓	✓		
Transmit the key code list for defined NV graphics	✓	✓		
Delete all NV graphics data	✓	✓		
Delete the specified NV graphics data	✓	✓		
Define the NV graphics data (raster format)	✓	✓		
Print the specified NV graphics data	✓	✓		
Transmit the key code list for defined download graphics	✓	✓		
Delete all download graphics data	✓	✓		
Delete the specified download graphics data	✓	✓		
Define the NV graphics data (raster format)	✓	✓		

Print the specified download graphics data	✓	✓		
Store the graphics data in the print buffer (raster format)	✓			
Specify Windows BMP NV graphics data	✓			
Specify Windows BMP download graphics data	✓			
Select bit-image mode	✓	✓	✓	✓
Status commands				
Enable/disable Automatic Status Back (ASB)	✓	✓	✓	✓
Customize ASB-status bits	✓	✓	✓	✓
Transmit status	✓	✓	✓	✓
Transmit real-time status	✓	✓	✓	✓
Enable/disable Automatic Status Back (ASB) for optional functions (extended status)	✓	✓	✓	✓
Bar code commands				
Print bar code	✓	✓*2		
Set bar code height	✓	✓	✓	✓
Set bar code width	✓	✓		
Select print position of HRI characters	✓	✓	✓	✓
Select font for HRI characters	✓	✓	✓	✓
Two-dimensional code commands				
PDF417: Set the number of columns in the data region	✓			
PDF417: Set the number of rows	✓			
PDF417: Set the width of the module	✓			
PDF417: Set the row height	✓			
PDF417: Set the error correction level	✓			
PDF417: Select the options	✓			
PDF417: Store the data in the symbol storage area	✓			

PDF417: Print the symbol data in the symbol storage area	✓			
PDF417: Transmit the size information of the symbol data in the symbol storage area	✓			
QR Code: Select the model	✓			
QR Code: Set the size of the module	✓			
QR Code: Set the error correction level	✓			
QR Code: Store the data in the symbol storage area	✓			
QR Code: Print the symbol data in the symbol storage data area	✓			
QR Code: Transmit the size information of the symbol data in the symbol storage area	✓			
MaxiCode: Select the mode	✓			
MaxiCode: Store the data in the symbol storage area	✓			
MaxiCode: Print the symbol data in the symbol storage area	✓			
MaxiCode: Transmit the size information of the symbol data in the symbol storage area	✓			
Two-dimensional GS1 DataBar: Set the width of module	✓			
Two-dimensional GS1 DataBar: Set the maximum width of GS1 DataBar Expanded Stacked	✓			
Two-dimensional GS1 DataBar: Store the data in the symbol storage area	✓			
Two-dimensional GS1 DataBar: Print the symbol data in the symbol storage area	✓			
Two-dimensional GS1 DataBar: Transmit the size information of the symbol data in the symbol storage area	✓			

Composite Symbology: Set the width of module	✓			
Composite Symbology: Set the maximum width of GS1 DataBar Expanded Stacked	✓			
Composite Symbology: Select font for HRI characters	✓			
Composite Symbology: Store the data in the symbol storage area	✓			
Composite Symbology: Print the symbol data in the symbol storage area	✓			
Composite Symbology: Transmit the size information of the symbol data in the symbol storage area	✓			
Macro function commands				
Start/end macro definition	✓	✓	✓	✓
Execute macro	✓	✓	✓	✓
Mechanism control commands				
Turn unidirectional print mode on/off	✓	✓	✓	✓
Return home		✓	✓	✓
Set/cancel cut sheet reverse eject	✓	✓	✓	✓
Release paper	✓	✓	✓	✓
Select cut mode and cut paper	✓			
Customized commands				
Change into the user setting mode	✓	✓	✓	✓
End the user setting mode session	✓	✓	✓	✓
Change the setting of the memory switch	✓	✓	✓	✓
Transmit the setting of the memory switch	✓	✓	✓	✓
Set the customized setting values	✓	✓	✓	✓
Transmit the customized setting values	✓	✓	✓	✓
Set the transmission conditions for the serial interface	✓	✓	✓	✓

Transmit the transmission conditions for the serial interface	✓	✓	✓	✓
Save the setting values from the work area into the storage area	✓	✓	✓	✓
Load the setting values stored in the storage area to the work area	✓	✓	✓	✓
Select the setting values loaded to the work area after the initialization process	✓	✓	✓	✓
Delete the specified record	✓	✓	✓	✓
Store the data in the specified record	✓	✓	✓	✓
Transmit the data in the specified record	✓	✓	✓	✓
Transmit capacity of the NV user memory currently being used	✓	✓	✓	✓
Transmit the remaining capacity of the NV user memory	✓	✓	✓	✓
Transmit the key code list	✓	✓	✓	✓
Delete all data in the NV user memory	✓	✓	✓	✓
Set 40 cpl mode	✓	✓	✓	✓
Miscellaneous commands				
Initialize printer	✓	✓	✓	✓
Transmit printer ID	✓	✓	✓	✓
Set horizontal and vertical motion units	✓	✓	✓	✓*1
Select peripheral device	✓	✓	✓	✓
Generate pulse	✓	✓	✓	✓
Generate pulse in real time	✓	✓	✓	✓
Execute power-off sequence	✓	✓	✓	✓
Clear buffer(s)	✓	✓	✓	✓
Enable/disable real-time command	✓	✓	✓	✓
Send real-time request to printer	✓	✓	✓	✓
Select page mode	✓	✓		
Select double-density page mode		✓		
Select standard mode	✓	✓		

Enable/disable transmission of paper status	✓	✓	✓	✓
Execute test print	✓	✓	✓	✓
Select the print speed	✓			
Select the number of parts for the thermal head energizing	✓			
Initialize maintenance counter	✓	✓	✓	✓
Transmit maintenance counter	✓	✓	✓	✓
Receipt enhancement commands				
Cancel set values for top/bottom logo printing	✓			
Transmit set values for top/bottom logo printing	✓			
Set top logo printing	✓			
Set bottom logo printing	✓			
Make extended settings for top/bottom logo printing	✓			
Enable/disable top/bottom logo printing	✓			
MICR control commands (only for models with the MICR reader)				
Transmit real-time status	✓	✓	✓	✓
Select MICR data handling	✓	✓	✓	✓
Read check paper	✓	✓	✓	✓
Load check paper to print starting position	✓	✓	✓	✓
Eject check paper	✓	✓	✓	✓
Request retransmission of check paper reading result	✓	✓	✓	✓
Clean MICR mechanism	✓	✓	✓	✓

*1: Fixed value

*2: Only for standard mode

Software and Manuals

The following software and manuals are provided for application development.

How to Get Drivers, Manuals, and the Utility

You can obtain drivers, manuals, and the TM-H6000IV Utility from one of the following URLs.

For customers in North America, go to the following web site:

<http://www.epsonexpert.com/> and follow the on-screen instructions.

For customers in other countries, go to the following web site:

<http://www.epson-pos.com/>

Printer Drivers

Software	Manual
EPSON Advanced Printer Driver (APD): In addition to ordinary Windows driver functions, this driver has controls specific to POS, such as controls for paper cut, a cash drawer, or customer display. The Status API (Epson original DLL) that monitors printer status and sends ESC/POS commands is also attached to this driver.	<ul style="list-style-type: none">• APD Install Manual• APD TM/BA/EU Printer Manual• APD Printer Specification• Devmode API/PRINTERINFO Manual• Status API Manual• Sample Program Guide
OPOS ADK: This OCX driver can control POS peripherals using OLE technology* ¹ . Because controlling POS peripherals with original commands is not required on the application side, efficient system development is possible.	<ul style="list-style-type: none">• OPOS Installation Manual• User's Manual• Application Development Guide• UnifiedPOS Retail Peripheral Architecture*²• Sample Program Guide
OPOS ADK for .NET: OPOS ADK for .NET allows you to develop applications that are compatible with Microsoft POS for .NET. When developing applications, use a separate development environment such as Microsoft Visual Studio .NET.	<ul style="list-style-type: none">• OPOS ADK for .NET Installation Guide• UnifiedPOS Retail Peripheral Architecture*²• User's Reference (SetupPOS)• Application Development Guide (POSPrinter TM-H6000IV)

Software	Manual
<p>JavaPOS ADK:</p> <p>JavaPOS is the standard specification which defines an architecture and device interface (API) to access various POS devices from a Java based system. Using JavaPOS standard API allows control with Java-based applications of functions inherent to each device. A flexible design with Java language and JavaPOS enables many different types of computer systems, such as stand alone or network configuration, to use a same application. You can use JavaPOS to build applications and drivers independently of platforms. This allows flexible configurations using thin clients to meet the system requirements.</p>	JavaPOS ADK Installation Guide
<p>EPSON TM Virtual Port Driver:</p> <p>This driver is a Serial-USB and Parallel-USB conversion driver to make an EPSON TM/BA/EU printer connected via USB accessible from a POS application through virtual COM ports and a virtual LPT port. Without making changes in the POS application that controls devices connected through serial or parallel interfaces, devices connected via USB can be directly controlled with ESC/POS commands.</p>	TM Virtual Port Driver User's Manual

*1: OLE technology developed by Microsoft divides software into part blocks. The OPOS driver is presupposed to be used with a development environment, such as Visual Basic, unlike ordinary Windows drivers. It is not a driver to be used for printing from commercial applications.

*2: This guide describes general information on how to control printers using the OPOS ADK (in the chapter "POS Printer" and "Appendix A"). It does not describe Epson's specific functions.

Utilities

Software	Manual
<p>TM-H6000IV Utility: Use for checking and setting the following functions:</p> <ul style="list-style-type: none"> • Current settings • Operation check • Storing logos • Paper reduction • Automatic paper cut • Printing control • Communication interface • Backup/restore 	<ul style="list-style-type: none"> • TM-H6000IV Utility User's Manual
<p>TM-H6000IV Printer Model Setting Utility: Use to change the printer model name when you use the TM-H6000IV with the APD Ver. 4.00 ~ 4.04.</p>	<p>TM-H6000IV Printer Model Setting Utility User's Manual</p>
<p>TM Net WinConfig: Use for IP address or wireless LAN setting.</p>	<ul style="list-style-type: none"> • TM Net WinConfig User's Guide • UB-E02 Technical Reference Guide • UB-R02/R03 Technical Reference Guide
<p>EpsonNet Simple Viewer: Use to monitor the network and the printer status.</p>	<p>EpsonNet Simple Viewer User's Manual</p>
<p>TM-H6000IV Remote Configuration Tool: Use to change settings and monitor the status of the TM-H6000IV connected by parallel/serial/USB to client computers (POS and KIOSK terminals) from an administrator computer over the network using EpsonNet Simple Viewer and the TM-H6000IV Utility.</p>	<p>TM/BA/EU Printer Remote Configuration Tool User's Manual</p>
<p>BMP File Converter: Use to convert the BMP image files used in Windows into a data format which can be interpreted by the TM-H6000IV. Conversion to multi-tone or black and white image command is possible. After execution, a binary file with the command string is created.</p>	<p>Readme</p>

Setting/Checking Modes

Besides the ordinary print mode, the printer has the following modes to set or check settings of the printer.

- Self-test Mode (See [page 86.](#))
- Hexadecimal Dumping Mode (See [page 89.](#))
- NV Graphics Print Mode (See [page 90.](#))
- Receipt Enhancement Information Print Mode (See [page 92.](#))
- Memory Switch Setting Mode (See [page 93.](#))

Self-test Mode

In the self-test mode, the printer prints the current status of the printer (on the roll paper) and resident characters as a test print (roll paper, slip paper, and validation paper).

You can confirm the following information with the status print.

- ROM version
- Interface setting
- Buffer capacity setting
- Busy condition setting
- Automatic line feed setting
- Customer display connection
- Resident character set
- Print density setting
- Installed devices (MICR unit, endorsement printer unit, validation unit)
- Maintenance information (thermal head, autocutter, impact head, MICR head)
- DIP switch settings

Starting the status print and test print on the roll paper

Follow the steps below to start a status print and test print on the roll paper.

- 1** Install the roll paper.
- 2** Close all covers and the receipt unit.
- 3** While pressing the Feed button, turn on the printer. (Keep pressing the button until the printer starts printing.)

The printer starts printing the current status of the printer on the roll paper.

NOTE

With the Ethernet interface, before printing starts, it takes 6 seconds if the IP address is fixed and 13 seconds if the IP address is obtained with the automatic setting. (It may take longer, depending on the response time from the host.)

When the printer finishes printing the printer status, the following message is printed and the Paper LED flashes. (The printer is now in the self-test wait mode.):

“Select Modes by pressing Feed button.
Continue SELF-TEST: Less than 1 second
Mode Selection : 1 second or more”

- 4** To start the test print, press the Feed button (less than 1 second).
The printer prints a rolling pattern on the roll paper, using only the built-in character set.

NOTE

If you select the mode selection, see ["NV Graphics Print Mode" on page 90](#), ["Receipt Enhancement Information Print Mode" on page 92](#), or ["Memory Switch Setting Mode" on page 93](#).

After printing the following message, the printer is initialized and returned to the normal mode.

“*** completed***”

Starting the test print on slip paper

Follow the steps below to start a test print on slip paper.

- 1** Close all covers and the receipt unit.
- 2** While pressing the Release button, turn on the printer. (Keep pressing the button until the Slip LED starts flashing.)
The printer goes into the slip insertion waiting status.
- 3** Insert slip paper.
The printer prints a rolling pattern on the slip paper, using only the built-in character set.

NOTE

For models with the endorsement printer, the printer prints on both sides of the paper.

After printing the following message, the printer is initialized and returned to the normal mode.

*** completed***

Starting the test print on validation paper

Follow the steps below to start a test print on validation paper.

- 1** Close all covers and the receipt unit.
- 2** While pressing the Feed button and the Release button, turn on the printer. (Keep pressing the buttons until the Slip LED starts flashing.)
The printer goes into the validation insertion waiting status.
- 3** Insert validation paper.
The printer prints a rolling pattern on the validation paper, using only the built-in character set.

After printing the following message, the printer is initialized and returned to the normal mode.

*** completed***

Hexadecimal Dumping Mode

In the hexadecimal dumping mode, the printer prints the data transmitted from a host computer in hexadecimal numbers and their corresponding characters on the roll paper.

Starting the hexadecimal dumping mode

Follow the steps below to run this mode.

CAUTION

- If there is no character corresponding to print data, "." is printed.
- If print data is less than one line, press the Feed button to print the line.
- Applications that confirm printer status may not work correctly during the hexadecimal dumping mode. The printer returns only the status for "Transmit real-time status."

- 1** Install the roll paper.
- 2** With the roll paper cover open, while pressing the Feed button, turn on the printer.
- 3** Close the roll paper cover.
The printer starts printing data received from then on in hexadecimal numbers and their corresponding characters.

Printing example:

```
Hexadecimal Dump
To terminate hexadecimal dump,
press FEED button three times.

1B 21 00 1B 26 02 40 40 1B 69 . ! . . & . @ . @ . i
1B 25 01 1B 63 34 00 1B 30 31 . % . . c 4 . . 0 1
41 42 43 44 45 46 47 48 49 4A A B C D E F G H I J

*** completed ***
```

Turn off the printer or press the Feed button 3 times to return to the normal mode.

NV Graphics Print Mode

You can confirm the following information on the roll paper by running NV graphics print mode:

- Capacity of the NV graphics
- Used amount of the NV graphics
- Unused capacity of the NV graphics
- Number of NV graphics that are registered
- Key code, number of dots in X direction, number of dots in Y direction
- NV graphics data

NOTE

For detailed information about NV graphics, see ["NV Graphics Memory" on page 22](#).

Starting the NV graphics print mode

Follow the steps below to run this mode.

- 1 Install the roll paper.
- 2 Close all covers and the receipt unit.
- 3 While pressing the Feed button, turn on the printer. (Keep pressing the button until the printer starts printing.)

The printer starts printing the current status of the printer.

NOTE

With the Ethernet interface, before printing starts, it takes 6 seconds if the IP address is fixed and 13 seconds if the IP address is obtained with the automatic setting. (It may take longer, depending on the response time from the host.)

When the printer finishes printing the printer status, the following message is printed and the Paper LED flashes. (The printer is now in the self-test wait mode.):

```

"Select Modes by pressing Feed button.
Continue SELF-TEST: Less than 1 second
Mode Selection      : 1 second or more"

```

- 4 Press the Feed button. (Keep pressing the button until the printer starts printing.)

The printer starts printing instructions.

-
- 5** After the printing has been completed, press the Feed button.
 - 6** Press the Feed button again. (Keep pressing the button until the printer starts printing.)

The printer starts printing the NV graphics information.

Turn the power off and on to return to the normal mode.

Receipt Enhancement Information Print Mode

You can confirm the following information on the roll paper by running the R/E information mode:

- Automatic top logo setting
- Automatic bottom logo setting
- Extended settings for automatic top/bottom logo

Starting the R/E information print mode

Follow the steps below to run this mode.

- 1** Install the roll paper.
- 2** Close all covers and the receipt unit.
- 3** While pressing the Feed button, turn the power on. (Keep pressing the button until the printer starts printing.)
The printer starts printing the current status of the printer.

NOTE

With the Ethernet interface, before printing starts, it takes 6 seconds if the IP address is fixed and 13 seconds if the IP address is obtained with the automatic setting. (It may take longer, depending on the response time from the host.)

When the printer finishes printing the printer status, the following message is printed and the Paper LED flashes. (The printer is now in the self-test wait mode.):

```

"Select Modes by pressing Feed button.
Continue SELF-TEST: Less than 1 second
Mode Selection      : 1 second or more"

```

- 4** Press the Feed button. (Keep pressing the button until the printer starts printing.)
The printer starts printing instructions.
- 5** After the printing has been completed, press the Feed button twice.
- 6** Press the Feed button again. (Keep pressing the button until the printer starts printing.)
The printer starts printing the R/E information.
Turn the power off and on to return to the normal mode.

Memory Switch Setting Mode

In the memory switch setting mode, you can set the following “memory switches (customized values),” which are software switches of this printer.

- Receipt print density
- Automatic paper reduction
- Roll paper width
- Power supply unit capacity
- Error control
- NV capacity
(User NV memory, NV graphics memory)
- Transmission speed for serial interface
- Autocutting at roll paper cover close
- Interface selection
- Receipt print speed
- Power on notice
- Command execution during offline

NOTE

For detailed information about memory switches, see ["Setting the Memory Switches/Receipt Enhancement" on page 65](#).

Starting the memory switch setting mode

Follow the steps below to run this mode.

- 1** Install the roll paper.
- 2** Close all covers and the receipt unit.
- 3** While pressing the Feed button, turn the power on. (Keep pressing the button until the printer starts printing.)
The printer starts printing the current status of the printer.

NOTE

With the Ethernet interface, before printing starts, it takes 6 seconds if the IP address is fixed and 13 seconds if the IP address is obtained with the automatic setting. (It may take longer, depending on the response time from the host.)

When the printer finishes printing the printer status, the following message is printed and the Paper LED flashes. (The printer is now in the self-test wait mode.):

“Select Modes by pressing Feed button.
Continue SELF-TEST: Less than 1 second
Mode Selection : 1 second or more”

- 4** Press the Feed button. (Keep pressing the button until the printer starts printing.)
The printer starts printing instructions.

- 5** After the printing has been completed, press the Feed button 3 times.
- 6** Press the Feed button again. (Keep pressing the button until the printer starts printing.)
The printer starts printing instructions. Follow them.

After one setting has been completed, the printer stores the setting and then starts initializing. After that, the printer returns to the normal mode.



Handling

This chapter describes basic handling of the printer.

Usage Precautions

- Make sure cords and foreign objects are not caught in the printer.
- Do not open the covers during printing or autocutting.
- Make sure that the printer is not subjected to any impact or vibration.
- Do not put any food or drink on the printer case.
- To prevent a paper jam, do not prevent paper from being ejected from the paper exit, and do not pull the paper being ejected.

Installing and Replacing the Ribbon Cartridge

NOTE

- It is recommended to use genuine Epson ink ribbon cartridges (ERC-32). Use of non-genuine ink ribbon cartridges may cause damage that is not covered by Epson's warranties.
- When the print is faint and the print quality is not acceptable, it is time to replace the ink ribbon cartridge with a new one.

- 1** Turn on the printer.
- 2** Open the front cover using the tabs on both sides of the front cover.

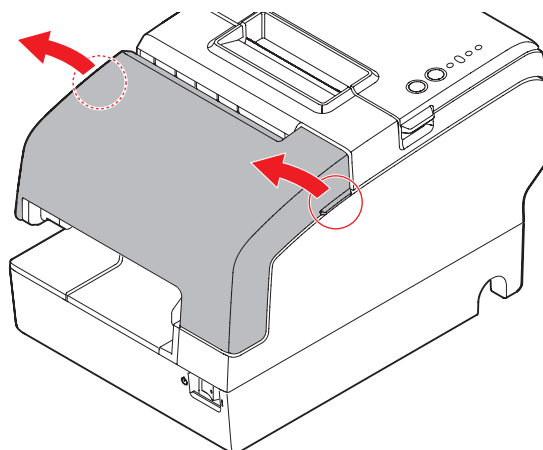

- 3** Remove the used ribbon cartridge, if there is one.
- 4** Turn the knob on the new ribbon cartridge in the direction of the arrow marked on the cartridge 2 or 3 times to remove any slack in the ribbon.

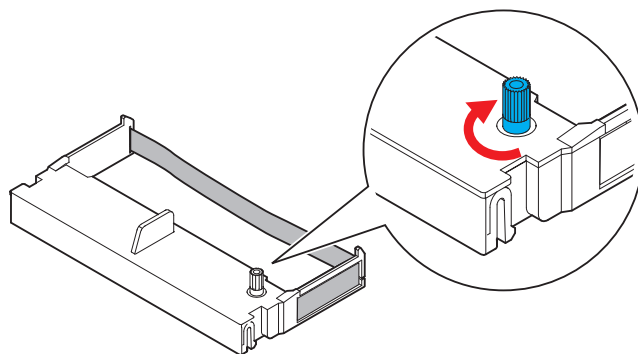

- 5** Insert a new ribbon cartridge until it clicks into place.
If there is slack or a fold in the ribbon, reinstall it.

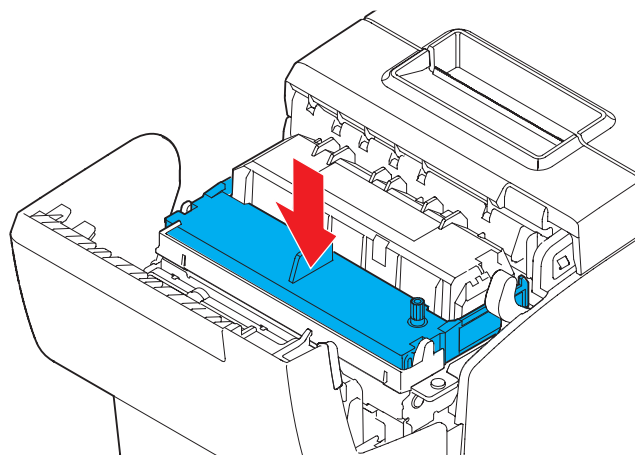

- 6** Turn the knob in the marked direction 2 or 3 times again to remove any slack in the ribbon.
- 7** Close the front cover.

Installing and Replacing the Ribbon Cartridge for E/P

For the models with the E/P (endorsement printer), follow the steps to install the ink ribbon cartridge for the endorsement printer.

NOTE

It is recommended to use genuine Epson ink ribbon cartridges (ERC-43). Use of non-genuine ink ribbon cartridges may cause damage that is not covered by Epson's warranties.

- 1** Turn on the printer.
- 2** Pull the lever on the left side of the receipt unit to open the receipt unit.

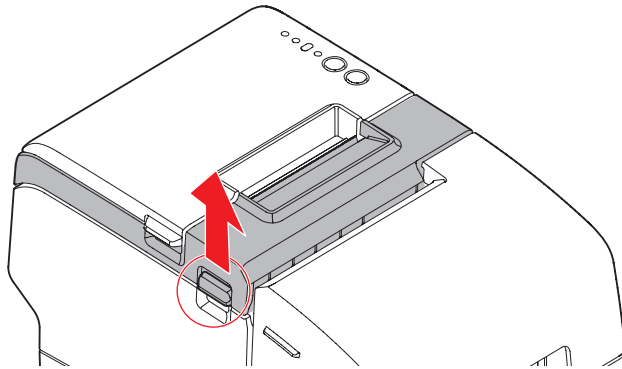

- 3** Remove the used ribbon cartridge, if there is one.
- 4** Turn the knob on the new ribbon cartridge in the direction of the arrow marked on the cartridge 2 or 3 times to remove any slack in the ribbon.

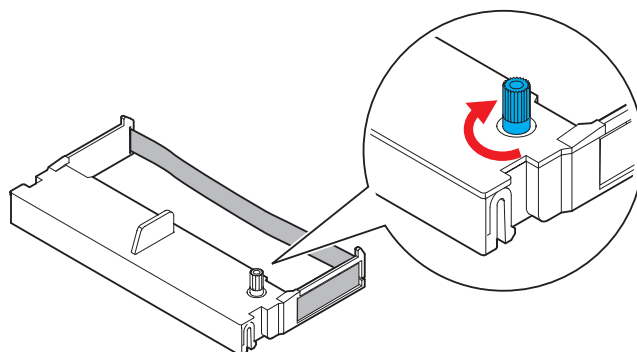

-
- 5** Insert a new ribbon cartridge until it clicks into place.
If there is slack or a fold in the ribbon, reinstall it.

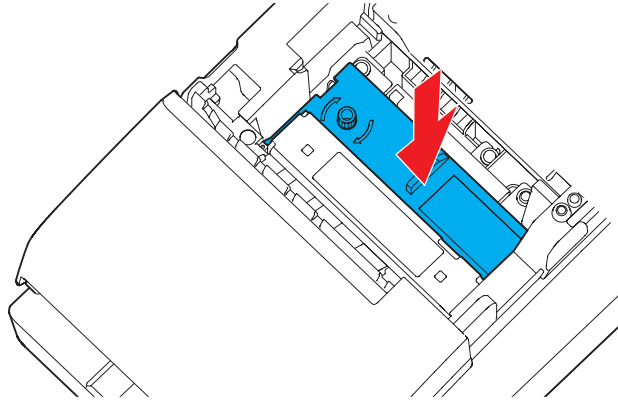

- 6** Turn the knob in the marked direction 2 or 3 times again to remove any slack in the ribbon.
- 7** Close the receipt unit.

Installing and Replacing Paper

**WARNING**

- **Do not open the roll paper cover and receipt unit during printing/autocutting.**
The printer may be damaged.
- **Do not touch the manual cutter with your hands.**
The manual cutter blade is sharp and may cause injury.

CAUTION

Use paper that meets the printer specifications. For details about paper specifications, see "Paper Specifications" on page 28.

Inserting Slip Paper

CAUTION

- Do not insert checks that have clips or staples. This may cause paper jams.
- The paper must be flat, without curls, folds, or wrinkles.

- 1** Turn on the printer.
- 2** Insert the paper face up with the right paper edge against the right side of the paper guide, and insert it as far as it will go.

NOTE

For models with the MICR reader, MICR reading is available by inserting the check paper so that the MICR characters on the paper are on the right side.

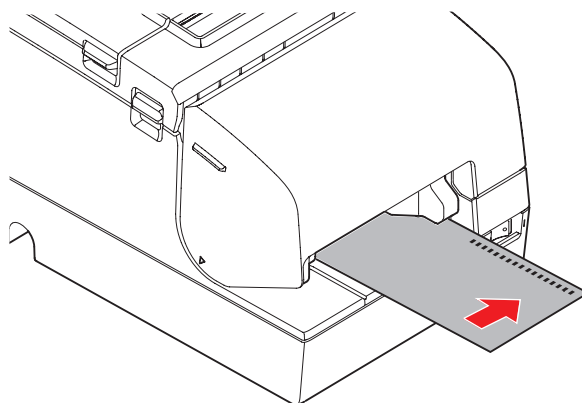

-
- 3** Insert the paper straight until the top edge of the paper touches the stopper.

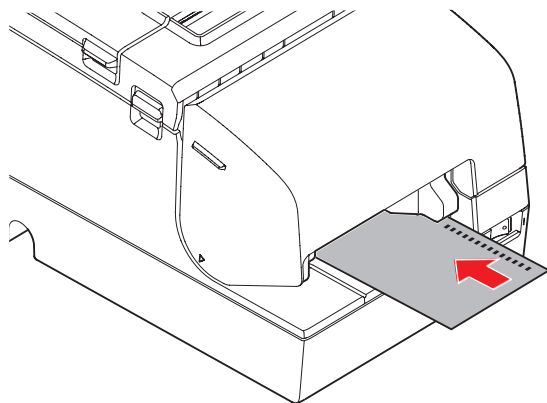

- 4** When the printer starts feeding the paper, release it immediately.
- 5** Pull the ejected paper straight up out of the printer.

Inserting Validation Paper (For Validation Models)

Insert the validation paper in the same way as normal slip paper (See ["Inserting Slip Paper" on page 99.](#)) or follow the steps below.

CAUTION

- Do not insert checks that have clips or staples. This may cause paper jams.
- The paper must be flat, without curls, folds, or wrinkles.

- 1 Turn on the printer.
- 2 Insert the paper with the right paper edge against the right side of the paper guide at the printer top, and insert it as far as it will go.

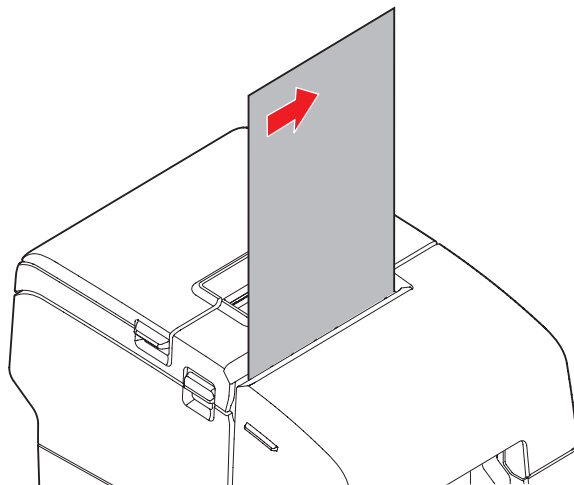

- 3 Insert the paper straight down until the bottom edge of the paper touches the stopper.

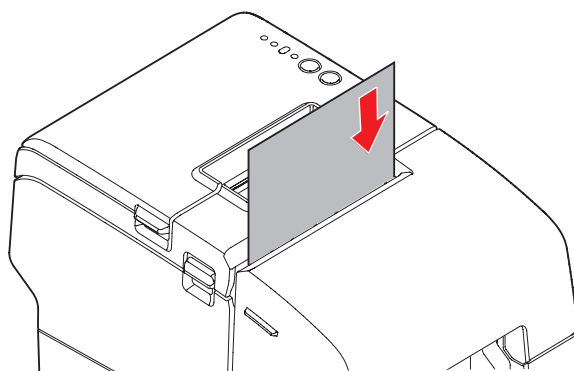

- 4 When the printer starts feeding the paper, release it immediately.
- 5 Pull the ejected paper straight up out of the printer.

Installing and Replacing Roll Paper

CAUTION

Paper must not be pasted to the roll paper spool.

- 1 Open the roll paper cover using the tabs on both sides of the roll paper cover.

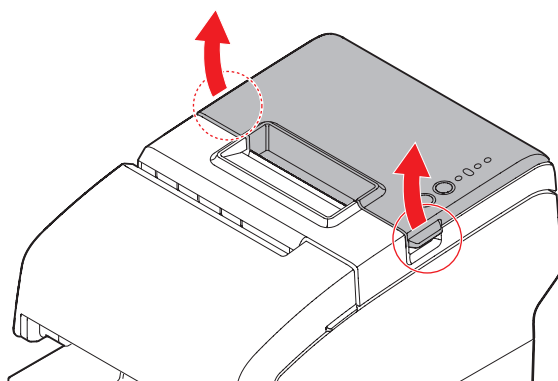

- 2 Remove the used roll paper core, if there is one.
- 3 Insert the roll paper in the correct direction.

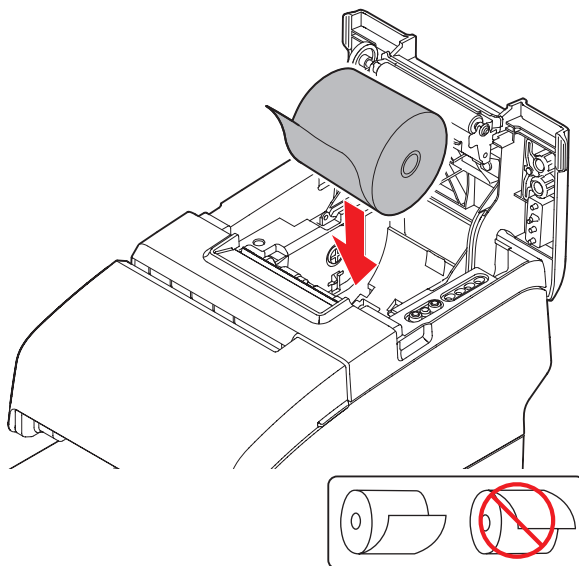

- 4** Pull out some paper, and close the roll paper cover.

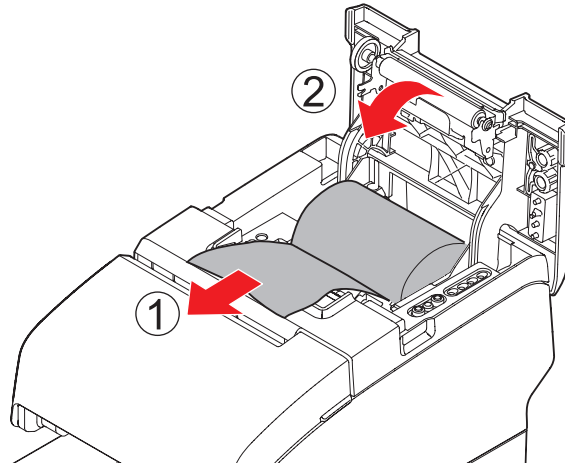

- 5** Tear off the paper with the manual cutter.

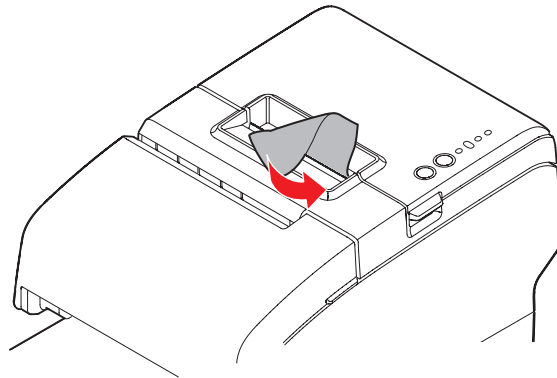

Removing Jammed Paper

Removing Jammed Slip Paper

- 1 Turn off the printer.
- 2 Open the front cover using the tabs on both sides of the front cover.

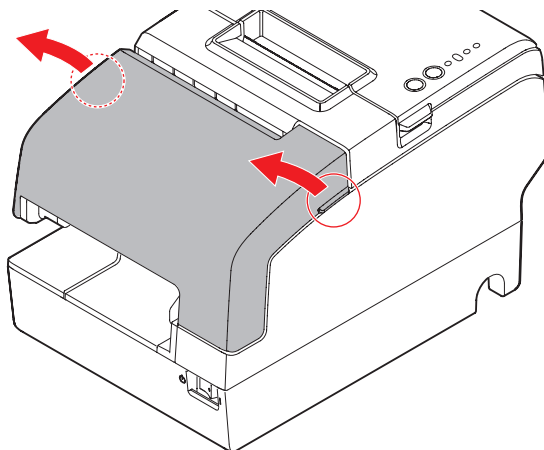

- 3 Open the front carriage unit using the lever at the right of the front carriage unit.

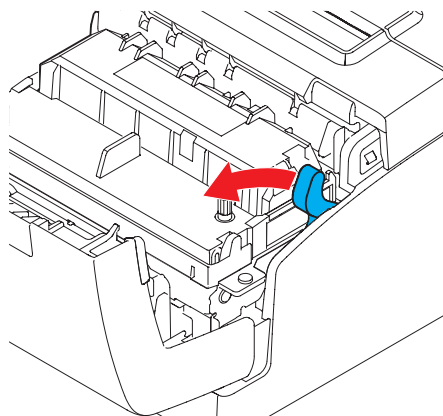

- 4 Remove the jammed paper.

Removing Jammed Roll Paper

When a roll paper jam occurs, never pull out the paper forcibly. Turn off the printer, open the roll paper cover, and remove the jammed paper.



Do not touch the thermal head (See "[Cleaning the Printer](#)" on page 106.) **because it can be very hot after printing.**

When roll paper cover will not open

When the roll paper cover is locked and will not open, follow the steps below to return the autocutter blade to the normal position to unlock the roll paper cover.

- 1 Turn off the printer.
- 2 Pull the lever on the left side of the receipt unit to open the receipt unit.

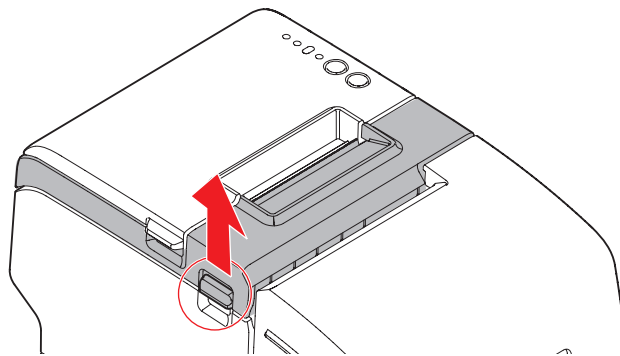

- 3 Turn the knob in the direction of the arrow until you see a pin in the opening.

This returns the autocutter blade to the normal position.

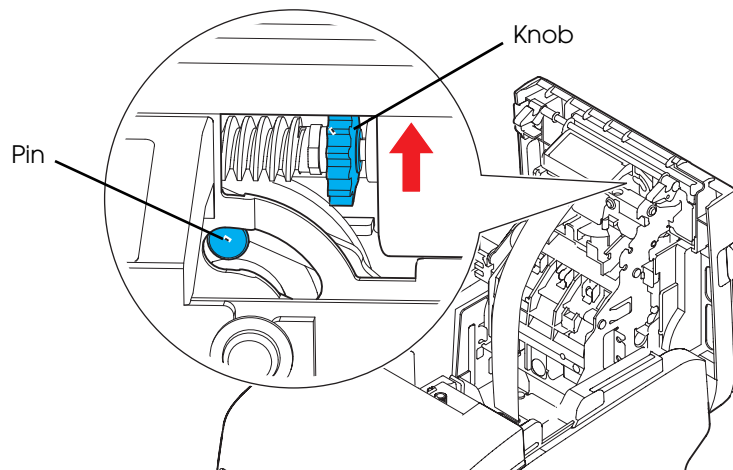

Cleaning the Printer

Cleaning the Printer Case

Be sure to unplug the AC cable from the wall socket and turn off the printer before cleaning. Wipe the dirt off the printer case with a dry cloth or a damp cloth.

CAUTION

Never clean the product with alcohol, benzene, thinner, or other such solvents. Doing so may damage or break the parts made of plastic and rubber.

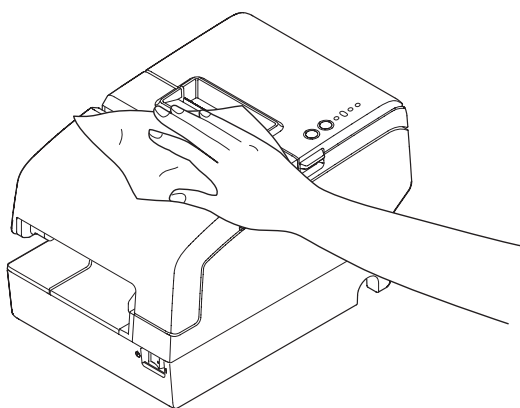

Cleaning the Thermal Head

Epson recommends cleaning the thermal head periodically (generally every 3 months) to maintain receipt print quality.



CAUTION

- After printing, the thermal head can be very hot. Do not touch it and let it cool before you clean it.
- Do not damage the thermal head by touching it with your fingers or any hard object.

Turn off the printer, open the roll paper cover, and clean the thermal elements of the thermal head with a cotton swab moistened with an alcohol solvent (ethanol or IPA).

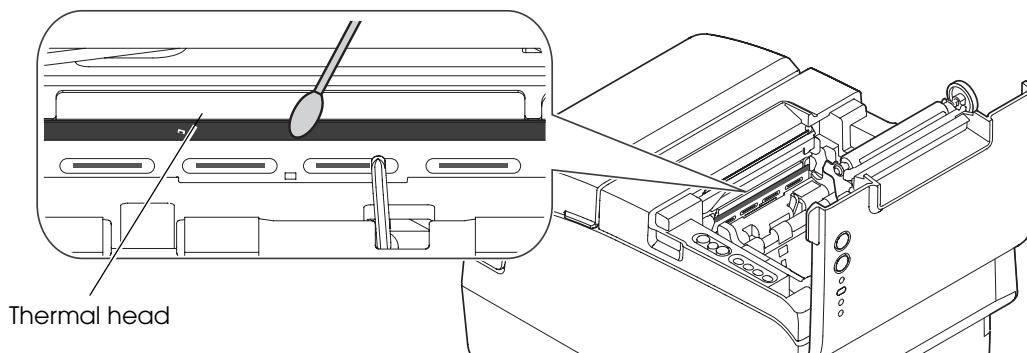

Cleaning the MICR Head (For Models with the MICR Reader)

When the MICR head becomes dirty, the printer cannot read MICR characters normally. Approximately every year, clean the MICR head with the following or an equivalent commercially available cleaning sheet:

KIC Products “Waffletechnology® MICR cleaning card”

CAUTION

- Be sure not to use an adhesive cleaning sheet.
- Be sure that the cleaning sheet is inserted with the correct side up and in the correct direction.
- Use a cleaning sheet only one time; then discard it.

NOTE

You can also perform MICR head cleaning with the TM-H6000IV Utility. For detailed information about the TM-H6000IV Utility, see the TM-H6000IV Utility User’s Manual.

- 1 Install the roll paper.
See ["Installing and Replacing Roll Paper" on page 102.](#)
- 2 Turn off the printer.
- 3 Open the roll paper cover.
- 4 While holding down the Release button, turn the power back on.
- 5 Press the Release button 7 times; then close the roll paper cover.
The printer prints the following message on the roll paper and the Slip LED flashes. (The printer is now in the slip insertion waiting state.):
RECOGNITION MODEPlease set check.
- 6 Insert the cleaning sheet like standard slip paper.
See ["Inserting Slip Paper" on page 99.](#)
- 7 Pull the ejected cleaning sheet straight up out of the printer.
- 8 Turn off the printer.

Preparing for Transport

Follow the steps below to transport the printer.

- 1** Turn off the printer.
- 2** Remove the power supply connector.
- 3** Remove the roll paper.
- 4** Pack the printer upright.

Replacement of the TM-H6000III

The TM-H6000IV is designed so that it can smoothly replace the TM-H6000III. This chapter describes precautions for the replacement.

Compatibility

Printing

The printing and character specifications are the same as those of the TM-H6000III. Without special configurations, the TM-H6000IV prints the same results as the TM-H6000III prints.

Number of Head Energizing Parts for Receipt Printing

For the TM-H6000IV, the initial setting of the number of head energizing parts is "One-part energizing." You can change the setting with the customized value (See "[Setting the Memory Switches/Receipt Enhancement](#)" on page 65.); however it does not usually need to be changed.

	TM-H6000IV	TM-H6000III
Number of head energizing part	<ul style="list-style-type: none"> • One-part energizing • Two-part energizing • Four-part energizing 	Not changeable

Printable Area

The printable area of the TM-H6000IV is the same as that of the TM-H6000III except for the bottom margin of endorsement printing.

	TM-H6000IV	TM-H6000III
Bottom margin	22 mm	Unrestricted

Cutting Method

The TM-H6000IV uses the partial cutting method (cutting with one point in left edge left uncut) as does the TM-H6000III.

Receive Buffer

You can set the receive buffer of the TM-H6000IV to 4 KB or 45 bytes with DIP switch 1-2 as with the TM-H6000III. The buffer full condition of the TM-H6000IV is the same as that of the TM-H6000III.

Memory Capacity

The sizes of the download buffer and NV graphics data of the TM-H6000IV are the same as those of the TM-H6000III.

Electrical Characteristics

The operating voltage of the TM-H6000IV is DC 24V \pm 7%. The current consumption differs, depending on the print duty.

	TM-H6000IV	TM-H6000III
Operating voltage	DC 24V \pm 7%	DC 24V \pm 10%

DIP Switches

The functional assignments of DIP switches are the same as those of the TM-H6000III except for DIP switches 2-3 and 2-4, and DIP switches 1-7 and 1-8 for the serial interface model.

Printer Status

The TM-H6000IV goes to the same status under the same conditions as the TM-H6000III. You can replace the TM-H6000IV with the TM-H6000III without modifying applications.

Logo Registration

The TM-H6000IV can register logos in the NV memory (NVRAM) with the TM-H6000IV Utility, while the TM-H6000III can register logos with the TM Flash LOGO Setup Utility for NVRAM (TM-Flogo).

Driver Compatibility

You can operate the TM-H6000IV with a driver for the TM-H6000III.

CAUTION

You cannot operate the TM-H6000III with a driver for the TM-H6000IV.

Advanced Printer Driver

If the TM-H6000III was controlled by APD Ver. 4.00 ~ 4.04, you need to change the TM-H6000IV printer model name to “TM-H6000III” using the TM-H6000IV Printer Model Setting Utility.

If the TM-H6000III was controlled by an APD other than Ver. 4.00 ~ 4.04, you can replace it with the TM-H6000IV without modifying the APD.

OPOS ADK

If the TM-H6000III was controlled by an OPOS ADK, you can replace it with the TM-H6000IV without modifying the OPOS ADK.

Two-Color Printing

You cannot perform two-color receipt printing with the TM-H6000IV, unlike the TM-H6000III.

Ink Ribbon Cartridge

For slip printing, the ink ribbon cartridge ERC-43 is used with the TM-H6000IV while ERC-41 was used with the TM-H6000III. For endorsement printing, you can use the same ink ribbon cartridge, ERC-32, as the TM-H6000III.

Overall Dimensions

You can place the TM-H6000IV in the same location as the TM-H6000III, since its overall dimensions and weight are smaller than those of the TM-H6000III.

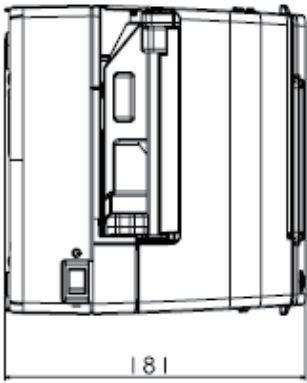
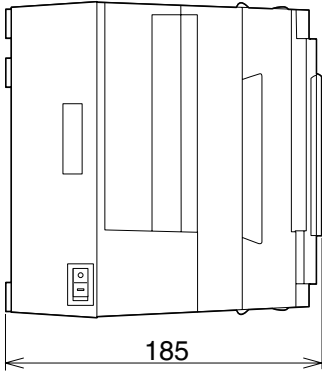
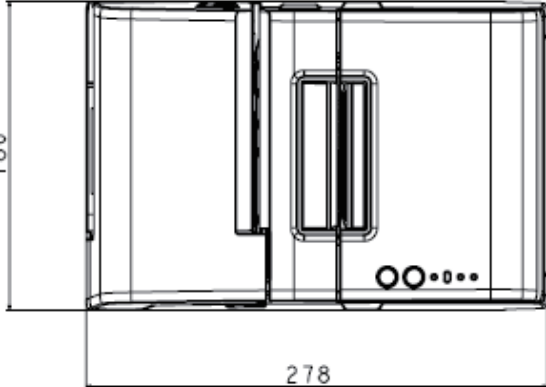
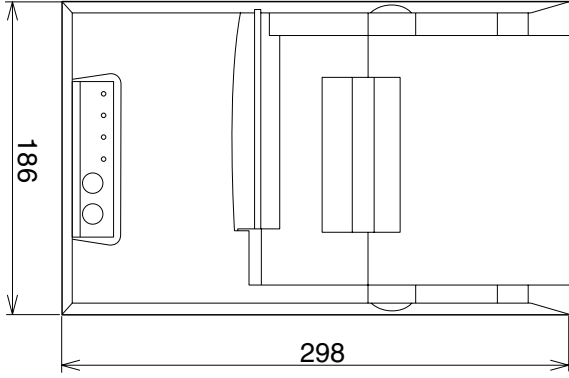
TM-H6000IV H: 181 × W: 186 × D: 278 mm 4.4 kg {H: 7.13 × W: 7.32" × D: 10.94" 9.70 lb}	TM-H6000III H: 185 × W: 186 × D: 298 mm 5.3 kg {H: 7.28 × W: 7.32" × D: 11.73" 11.68 lb}
	
	

The figures above are those of the standard model with the MICR reader and E/P.

Excluding the connector cover.

Additional Functions and Functional Improvements

Print Speed

The TM-H6000IV has increased the print speed of endorsement and receipt printing. Also, the receipt print speed of the TM-H6000IV is selectable from 13 levels with the customized value.

	TM-H6000IV	TM-H6000III
Endorsement print speed*	Approx. 4.0 lps	Approx. 1.9 lps
Receipt print speed	Max. 300 mm/s	Max. 200 mm/s
Receipt print speed setting (Customized value)	Level 1 to 13	—

*: When printing 40 columns per line with 17.8 cpi when the head energizing time is set to normal mode.

lps: lines per second

cpi: characters per inch (characters per 25.4 mm)

NOTE

- Depending on print conditions such as print duty, print head temperature, and data transmission speed, receipt print speed is automatically adjusted.
- For detailed information about the customized value, see "[Setting the Memory Switches/Receipt Enhancement](#)" on page 65.

Receipt Print Density

The receipt print density of the TM-H6000IV is selectable from 13 levels with the customized value.

Also, it can be set with DIP switches (2-3/2-4) as can the TM-H6000III. However, the TM-H6000IV has 3 levels while the TM-H6000III has 4 levels.

NOTE

For detailed information about the customized value, see "[Setting the Memory Switches/Receipt Enhancement](#)" on page 65.

Slip Paper

You can use thicker slip paper with the TM-H6000IV than with the TM-H6000III. You can also use copy paper for endorsement printing with the TM-H6000IV.

	TM-H6000IV	TM-H6000III
Thickness of normal paper (single-ply)	0.09 ~ 0.22 mm	0.09 ~ 0.20 mm
Total thickness of copy paper (slip)	0.09 ~ 0.47 mm	0.09 ~ 0.31 mm
Total thickness of copy paper (endorsement)	0.09 ~ 0.31 mm	Not available

CAUTION

Copy capability is greatly influenced by the ambient temperature, so printing must be performed under the specified conditions. (See "[Paper Specifications](#)" on page 28.)

Bar codes

With the TM-H6000IV, printing the following bar codes and two-dimensional symbols is additionally possible.

- GS1-128
- GS1 DataBar Omnidirectional
- GS1 DataBar Truncated
- GS1 DataBar Stacked
- GS1 DataBar Stacked Ominidirectional
- GS1 DataBar Limited
- GS1 DataBar Expanded
- GS1 DataBar Expanded Stacked
- MaxiCode
- Composite Symbology

Tone

With the TM-H6000IV, graphics tone setting (monochrome/multi-tone) is possible.

Interface

The USB interface is added to the main unit of the TM-H6000IV serial or parallel interface models as standard equipment.

Connection of Customer Display

When you use the serial or USB interface with the TM-H6000IV, you can connect the customer display (DM-D) directly to the printer.

Customized Value

For the TM-H6000IV, the following customized value functions are added. However, the function to select the black-color density in two-color printing is deleted, since the TM-H6000IV cannot perform two-color printing.

- Roll paper width
- Receipt print speed
- Interface selection
- Command execution during offline
- Number of head energizing parts
- Power supply unit capacity
- Automatic paper cut when the cover is closed
- Automatic paper-saving (upper space reduction)
- Automatic paper-saving (lower space reduction)
- Automatic paper-saving (line space reduction rate)
- Automatic paper-saving (line feed reduction rate)
- Automatic paper-saving (bar code height reduction rate)
- Print density in multi-tone printing
- Transmission speed for serial interface



For detailed information about the customized value, see "[Setting the Memory Switches/Receipt Enhancement](#)" on page 65.

R/E Information Printing Mode

The TM-H6000IV has a Receipt Enhancement (R/E) Information Printing mode (See [page 92.](#)) that lets you confirm the following information:

- Automatic top logo setting
- Automatic bottom logo setting
- Extended settings for automatic top/bottom logo

Memory Switch Setting Mode

The TM-H6000IV has a Memory Switch Setting mode (See [page 93.](#)) that lets you set the following memory switches:

- Receipt print density
- Automatic paper reduction
- Roll paper width
- Power supply unit capacity
- Error control
- NV capacity
(User NV memory, NV graphics memory)
- Transmission speed for serial interface
- Autocutting at roll paper cover close
- Interface selection
- Receipt print speed
- Power on notice
- Command execution during offline

Maintenance Counter

For the TM-H6000IV, the following maintenance counters are added.

- Number of the carriage driving times for slip printing (resettable/cumulative)
- Number of line feeds for receipt printing (resettable/cumulative)
- Number of times driving platen/roller opening and closing mechanism (resettable/cumulative)

Power Supply Unit Capacity

For the TM-H6000IV, the power supply load can be lowered by automatically changing the print speed, depending on the print duty. You can set this function with the customized value.

NOTE

For information about how to set the customized value, see "[Setting the Memory Switches/Receipt Enhancement](#)" on [page 65](#).

USB Low Power Consumption Mode

With the TM-H6000IV, you can enable the USB low power consumption mode with DIP switch 1-8.

Appendix

Specifications of Interfaces and Connectors

NOTE

For detailed information about LAN or wireless LAN, see one of the following:

- LAN: UB-E02 Technical Reference Guide
- Wireless LAN: UB-R02/R03 Technical Reference Guide

RS-232 Serial Interface

Interface board specifications (RS-232-compliant)

Item		Specifications
Data transfer method		Serial
Synchronization		Asynchronous
Handshake		Select one of the following with DIP switch 1-3: <ul style="list-style-type: none"> • DTR/DSR • XON/XOFF
Signal level	MARK	-3V to -15V logic "1"/OFF
	SPACE	+3V to +15V logic "0"/ON
Bit length		Select one of the following with DIP switch 1-4: <ul style="list-style-type: none"> • 7 bit • 8 bit
Transmission speed (bps: bits per second)		<ul style="list-style-type: none"> • Select one of the following with DIP switch 1-7/1-8: 4800/9600/19200 bps • Select one of the following with commands: 2400/4800/9600/19200/38400/57600/115200 bps
Parity check		Select one of the following with DIP switch 1-5: <ul style="list-style-type: none"> • Yes • No
Parity selection		Select one of the following with DIP switch 1-6: <ul style="list-style-type: none"> • Even • Odd
Stop bit		1 or more bits However, the stop bit for data transfer from the printer is fixed to 1 bit.
Connector	Printer side	DSUB 25-pin (female) connector

Functions of each connector pin

Pin no.	Signal name	Signal direction	Function
1	FG	—	Frame ground
2	TXD	Output	Transmission data
3	RXD	Input	Reception data
4	RTS	Output	Equivalent to DTR signal (pin 20)
6	DSR	Input	<p>This signal indicates whether the host computer can receive data.</p> <p>SPACE indicates that the host computer can receive data. MARK indicates that the host computer cannot receive data.</p> <p>When DTR/DSR control is selected, the printer transmits data after confirming this signal (except if transmitted using some ESC/POS commands).</p> <p>When XON/XOFF control is selected, the printer does not check this signal.</p> <p>Changing DIP switch 2-7 lets this signal be used as a printer reset signal.</p> <p>When you use this signal as the printer's reset signal, the printer is reset when the signal remains MARK for a pulse width of 1 ms or more.</p>
7	SG	—	Signal ground
20	DTR	Output	<p>1) When DTR/DSR control is selected, this signal indicates whether the printer is BUSY.</p> <ul style="list-style-type: none"> • SPACE status <p>Indicates that the printer is ready to receive data.</p> <ul style="list-style-type: none"> • MARK status <p>Indicates that the printer is BUSY. Set BUSY conditions with DIP switch 2-1.</p> <p>2) When XON/XOFF control is selected, the signal indicates that the printer is properly connected and ready to receive data from the host. The signal is always SPACE, except in the following cases:</p> <ul style="list-style-type: none"> • During the period from when power is turned on to when the printer is ready to receive data. • During the self-test.
25	INT	Input	<p>Changing DIP switch 2-8 enables this signal to be used as a reset signal for the printer. The printer is reset if the signal remains at SPACE for a pulse width of 1 ms or more.</p>

XON/XOFF

When XON/XOFF control is selected, the printer transmits the XON or XOFF signals as follows. The transmission timing of XON/XOFF differs, depending on the setting of DIP switch 2-1.

Signal	Printer status	DIP switch 2-1	
		1 (ON)	0 (OFF)
XON	1) When the printer goes online after turning on the power (or reset using the interface)	Transmit	Transmit
	2) When the receive buffer is released from the buffer full state	Transmit	Transmit
	3) When the printer switches from offline to online	—	Transmit
	4) When the printer recovers from an error using some ESC/POS commands	—	Transmit
XOFF	5) When the receive buffer becomes full	Transmit	Transmit
	6) When the printer switches from online to offline	—	Transmit

Code

The hexadecimal numbers corresponding to the XON/XOFF codes are shown below.

- XON code: 11H
- XOFF code: 13H



- When the printer goes from offline to online and the receive buffer is full, XON is not transmitted.
- When the printer goes from online to offline and the receive buffer is full, XOFF is not transmitted.
- When DIP switch 2-1 is off, XON is not transmitted as long as the printer is offline, even if a receive buffer full state has been cleared.

IEEE 1284 Parallel Interface

Modes

The IEEE 1284 parallel interface supports the following two modes.

Mode	Communication direction	Other information
Compatibility mode	Host → Printer communication	Centronics-compliant
Reverse mode	Printer → Host communication	Assumes a data transfer from an asynchronous printer

Compatibility Mode

Compatibility mode allows data transmission from host to printer only: Centronics-compatible.

Specification

Data transmission	8-bit parallel
Synchronization	Externally supplied $\overline{\text{STROBE}}$ signals
Handshaking	$\overline{\text{ACK}}$ and BUSY signals
Signal levels	TTL-compatible connector
Connector	ADS-B36BLFDR176 (HONDA) or equivalent product
Reverse communication	Nibble or byte mode

Reverse Mode

The transfer of status data from the printer to the host proceeds in the nibble or byte mode.

This mode allows data transfer from an asynchronous printer under the control of the host. Data transfers in the nibble mode are made via the existing control lines in units of four bits (a nibble). In the byte mode, data transfer proceeds by making the 8-bit data lines bidirectional. Both modes fail to proceed concurrently in the compatibility mode, thereby causing half-duplex transmission.

Interface signals

Pin	Source	Compatibility Mode	Nibble Mode	Byte Mode
1	Host	Strobe	HostClk	HostClk
2	Host/Ptr	Data0 (LSB)	Data0 (LSB)	Data0 (LSB)
3	Host/Ptr	Data1	Data1	Data1
4	Host/Ptr	Data2	Data2	Data2
5	Host/Ptr	Data3	Data3	Data3
6	Host/Ptr	Data4	Data4	Data4
7	Host/Ptr	Data5	Data5	Data5
8	Host/Ptr	Data6	Data6	Data6
9	Host/Ptr	Data7 (MSB)	Data7 (MSB)	Data7 (MSB)
10	Printer	$\overline{\text{Ack}}$	PtrClk	PtrClk
11	Printer	Busy	PtrBusy/Data3,7	PtrBusy
12	Printer	Perror	AckDataReq/Data2,6	AckDataReq
13	Printer	Select	Xflag/Data1,5	Xflag
14	Host	$\overline{\text{AutoFd}}$	HostBusy k	HostBusy
15		NC	ND	ND
16		GND	GND	GND
17		FG	FG	FG
18	Printer	Logic-H	Logic-H	Logic-H
19		GND	GND	GND
20		GND	GND	GND
21		GND	GND	GND
22		GND	GND	GND
23		GND	GND	GND
24		GND	GND	GND
25		GND	GND	GND
26		GND	GND	GND
27		GND	GND	GND

Pin	Source	Compatibility Mode	Nibble Mode	Byte Mode
28		GND	GND	GND
29		GND	GND	GND
30		GND	GND	GND
31	Host	$\overline{\text{Init}}$	$\overline{\text{Init}}$	$\overline{\text{Init}}$
32	Printer	$\overline{\text{Fault}}$	$\overline{\text{DataAvail/Data0,4}}$	$\overline{\text{DataAvail}}$
33		GND	ND	ND
34	Printer	DK_STATUS	ND	ND
35	Printer	+5V	ND	ND
36	Host	$\overline{\text{SelectIn}}$	1284-Active	1284-Active

NC: Not Connected

ND: Not Defined



- A signal name with a rule above it indicates an “L” active signal.
- Bidirectional communications cannot take place unless all signal names for both sides correspond to each other.
- Connect all signal lines using a twisted-pair cable. Connect the return side to the signal ground level.
- Make sure the signals satisfy electrical characteristics.
- Set the leading edge and trailing edge times to 0.5 ms or less.
- Do not ignore $\overline{\text{Ack}}$ or BUSY signals during a data transfer. Ignoring such signals may result in data corruption.
- Make the interface cables as short as possible.

USB (Universal Serial Bus) Interface

Outline

- Full-speed transmission at 12 Mbps [bps: bits per second]
- Plug & Play, Hot Insertion & Removal

USB transmission specifications

USB function

Overall specifications	According to USB 2.0 specifications
Transmission speed	USB Full-Speed (12 Mbps)
Transmission method	USB bulk transmission method
Power supply specifications	USB self power supply function
Current consumed by USB bus	2 mA
USB packet size (with full-speed connection)	
USB bulk OUT (TM)	64 bytes
USB bulk IN (TM)	64 bytes
USB device class	USB vendor-defined class

Status transmission from printer with USB interface

In order to ensure that there is no lack of status data, it is necessary to periodically retrieve status data at the host computer.

Unlike RS-232 transmission, status cannot spontaneously interrupt data transmission to the host computer.

The printer has a 128-byte status data buffer. Statuses that exceed the buffer capacity are canceled.

Character Code Tables

CAUTION

- The character code tables show only character configurations. They do not show the actual print pattern.
- "SP" in the table shows a space.

Common to All Pages

When the international character set (See ["International Character Sets" on page 137.](#)) is USA:

HEX	0	1	2	3	4	5	6	7
0	NUL 0	DLE 16	SP 32	0 48	@ 64	P 80	~ 96	p 112
1		XON 17	! 33	1 49	A 65	Q 81	a 97	q 113
2			" 34	2 50	B 66	R 82	b 98	r 114
3		XOFF 19	# 35	3 51	C 67	S 83	c 99	s 115
4	EOT 4	DC4 20	\$ 36	4 52	D 68	T 84	d 100	t 116
5	ENQ 5	NAK 21	% 37	5 53	E 69	U 85	e 101	u 117
6	ACK 6		& 38	6 54	F 70	V 86	f 102	v 118
7			' 39	7 55	G 71	W 87	g 103	w 119
8		CAN 24	(40	8 56	H 72	X 88	h 104	x 120
9	HT 9) 41	9 57	I 73	Y 89	i 105	y 121
A	LF 10		* 42	: 58	J 74	Z 90	j 106	z 122
B		ESC 27	+ 43	; 59	K 75	[91	k 107	{ 123
C	FF 12	FS 28	, 44	< 60	L 76	\ 92	l 108	 124
D	CR 13	GS 29	- 45	= 61	M 77] 93	m 109	} 125
E		RS 30	· 46	> 62	N 78	^ 94	n 110	~ 126
F			/ 47	? 63	O 79	_ 95	o 111	SP 127

Page 0 (PC437: USA, Standard Europe)

HEX	8	9	A	B	C	D	E	F
0	Ç <small>128</small>	É <small>144</small>	á <small>160</small>	☼ <small>176</small>	Ł <small>192</small>	⋈ <small>208</small>	α <small>224</small>	≡ <small>240</small>
1	Ü <small>129</small>	æ <small>145</small>	í <small>161</small>	☼ <small>177</small>	Ł <small>193</small>	⋈ <small>209</small>	β <small>225</small>	± <small>241</small>
2	é <small>130</small>	Æ <small>146</small>	ó <small>162</small>	☼ <small>178</small>	Ṭ <small>194</small>	π <small>210</small>	Γ <small>226</small>	≥ <small>242</small>
3	â <small>131</small>	ô <small>147</small>	ú <small>163</small>	l <small>179</small>	ṭ <small>195</small>	⋈ <small>211</small>	π <small>227</small>	≤ <small>243</small>
4	ä <small>132</small>	ö <small>148</small>	ñ <small>164</small>	ł <small>180</small>	– <small>196</small>	Ł <small>212</small>	Σ <small>228</small>	ƒ <small>244</small>
5	à <small>133</small>	ò <small>149</small>	Ñ <small>165</small>	ł <small>181</small>	† <small>197</small>	ƒ <small>213</small>	σ <small>229</small>	Ј <small>245</small>
6	ã <small>134</small>	û <small>150</small>	ä <small>166</small>	ł <small>182</small>	ṭ <small>198</small>	π <small>214</small>	μ <small>230</small>	÷ <small>246</small>
7	ç <small>135</small>	ù <small>151</small>	o <small>167</small>	π <small>183</small>	ł <small>199</small>	⋈ <small>215</small>	τ <small>231</small>	≈ <small>247</small>
8	ê <small>136</small>	ÿ <small>152</small>	ı <small>168</small>	ƒ <small>184</small>	Ł <small>200</small>	≠ <small>216</small>	φ <small>232</small>	° <small>248</small>
9	ë <small>137</small>	ö <small>153</small>	ƒ <small>169</small>	ł <small>185</small>	ƒ <small>201</small>	Ј <small>217</small>	θ <small>233</small>	• <small>249</small>
A	è <small>138</small>	ü <small>154</small>	ƒ <small>170</small>	ł <small>186</small>	⋈ <small>202</small>	ƒ <small>218</small>	Ω <small>234</small>	• <small>250</small>
B	ï <small>139</small>	ϕ <small>155</small>	½ <small>171</small>	π <small>187</small>	π <small>203</small>	■ <small>219</small>	δ <small>235</small>	√ <small>251</small>
C	î <small>140</small>	£ <small>156</small>	¼ <small>172</small>	ł <small>188</small>	ł <small>204</small>	■ <small>220</small>	ω <small>236</small>	n <small>252</small>
D	ì <small>141</small>	¥ <small>157</small>	ı <small>173</small>	ł <small>189</small>	= <small>205</small>	l <small>221</small>	φ <small>237</small>	² <small>253</small>
E	Ä <small>142</small>	ƒ <small>158</small>	« <small>174</small>	Ј <small>190</small>	ł <small>206</small>	l <small>222</small>	ε <small>238</small>	■ <small>254</small>
F	Å <small>143</small>	f <small>159</small>	» <small>175</small>	ƒ <small>191</small>	Ł <small>207</small>	■ <small>223</small>	∩ <small>239</small>	SP <small>255</small>

HEX	8	9	A	B	C	D	E	F
0	ー 128	⊥ 144	SP 160	ー 176	タ 192	ミ 208	ニ 224	× 240
1	ー 129	〒 145	。 161	ア 177	チ 193	ム 209	ト 225	円 241
2	■ 130	† 146	「 162	イ 178	ツ 194	メ 210	キ 226	年 242
3	■ 131	† 147	」 163	ウ 179	テ 195	モ 211	ト 227	月 243
4	■ 132	ー 148	、 164	エ 180	ト 196	ヤ 212	▲ 228	日 244
5	■ 133	ー 149	・ 165	オ 181	ナ 197	ユ 213	▲ 229	時 245
6	■ 134	丨 150	ヲ 166	カ 182	ニ 198	ヨ 214	▼ 230	分 246
7	■ 135	丨 151	ア 167	キ 183	ヌ 199	ラ 215	▼ 231	秒 247
8	丨 136	「 152	イ 168	ク 184	ネ 200	リ 216	♠ 232	〒 248
9	丨 137	〒 153	ウ 169	ケ 185	ノ 201	ル 217	♥ 233	市 249
A	丨 138	⌒ 154	エ 170	コ 186	ハ 202	レ 218	♦ 234	区 250
B	丨 139	」 155	オ 171	サ 187	ヒ 203	ロ 219	♣ 235	町 251
C	■ 140	「 156	ヤ 172	シ 188	フ 204	ワ 220	● 236	村 252
D	■ 141	ゝ 157	ユ 173	ス 189	ヘ 205	ン 221	〇 237	人 253
E	■ 142	ゝ 158	ヨ 174	セ 190	ホ 206	” 222	/ 238	☑ 254
F	† 143	ノ 159	ツ 175	リ 191	マ 207	。 223	＼ 239	SP 255

Page 2 (PC850: Multilingual)

HEX	8	9	A	B	C	D	E	F
0	Ç <small>128</small>	É <small>144</small>	á <small>160</small>	☼ <small>176</small>	Ł <small>192</small>	Ǿ <small>208</small>	Ó <small>224</small>	- <small>240</small>
1	Ü <small>129</small>	æ <small>145</small>	í <small>161</small>	☼ <small>177</small>	Ł <small>193</small>	Đ <small>209</small>	β <small>225</small>	± <small>241</small>
2	é <small>130</small>	Æ <small>146</small>	ó <small>162</small>	☼ <small>178</small>	Т <small>194</small>	Ê <small>210</small>	Ô <small>226</small>	= <small>242</small>
3	â <small>131</small>	ô <small>147</small>	ú <small>163</small>	l <small>179</small>	† <small>195</small>	Ë <small>211</small>	ò <small>227</small>	¼ <small>243</small>
4	ä <small>132</small>	ö <small>148</small>	ñ <small>164</small>	l <small>180</small>	- <small>196</small>	È <small>212</small>	õ <small>228</small>	¶ <small>244</small>
5	à <small>133</small>	ò <small>149</small>	Ñ <small>165</small>	Á <small>181</small>	† <small>197</small>	l <small>213</small>	õ <small>229</small>	§ <small>245</small>
6	ã <small>134</small>	û <small>150</small>	ä <small>166</small>	Â <small>182</small>	ã <small>198</small>	Í <small>214</small>	μ <small>230</small>	÷ <small>246</small>
7	ç <small>135</small>	ù <small>151</small>	o <small>167</small>	À <small>183</small>	Ǻ <small>199</small>	Î <small>215</small>	þ <small>231</small>	· <small>247</small>
8	ê <small>136</small>	ÿ <small>152</small>	¿ <small>168</small>	© <small>184</small>	Ł <small>200</small>	Ï <small>216</small>	þ <small>232</small>	° <small>248</small>
9	ë <small>137</small>	ö <small>153</small>	® <small>169</small>	¶ <small>185</small>	Ɔ <small>201</small>	Ј <small>217</small>	Ú <small>233</small>	¨ <small>249</small>
A	è <small>138</small>	ü <small>154</small>	¬ <small>170</small>	¶ <small>186</small>	Ł <small>202</small>	Г <small>218</small>	Û <small>234</small>	• <small>250</small>
B	ï <small>139</small>	ø <small>155</small>	½ <small>171</small>	¶ <small>187</small>	π <small>203</small>	■ <small>219</small>	Ü <small>235</small>	¹ <small>251</small>
C	î <small>140</small>	£ <small>156</small>	¼ <small>172</small>	¶ <small>188</small>	¶ <small>204</small>	■ <small>220</small>	Ý <small>236</small>	³ <small>252</small>
D	ì <small>141</small>	Ø <small>157</small>	ì <small>173</small>	¢ <small>189</small>	= <small>205</small>	¡ <small>221</small>	Ý <small>237</small>	² <small>253</small>
E	Ä <small>142</small>	× <small>158</small>	« <small>174</small>	¥ <small>190</small>	¶ <small>206</small>	Ï <small>222</small>	̄ <small>238</small>	■ <small>254</small>
F	Å <small>143</small>	f <small>159</small>	» <small>175</small>	₱ <small>191</small>	α <small>207</small>	■ <small>223</small>	˘ <small>239</small>	SP <small>255</small>

HEX	8	9	A	B	C	D	E	F
0	Ç <small>128</small>	É <small>144</small>	á <small>160</small>	☼ <small>176</small>	Ł <small>192</small>	⌚ <small>208</small>	α <small>224</small>	≡ <small>240</small>
1	ü <small>129</small>	À <small>145</small>	í <small>161</small>	☼ <small>177</small>	⊥ <small>193</small>	⌚ <small>209</small>	β <small>225</small>	± <small>241</small>
2	é <small>130</small>	È <small>146</small>	ó <small>162</small>	☼ <small>178</small>	τ <small>194</small>	π <small>210</small>	Γ <small>226</small>	≥ <small>242</small>
3	â <small>131</small>	ô <small>147</small>	ú <small>163</small>	l <small>179</small>	† <small>195</small>	⌚ <small>211</small>	π <small>227</small>	≤ <small>243</small>
4	ã <small>132</small>	õ <small>148</small>	ñ <small>164</small>	† <small>180</small>	- <small>196</small>	Ł <small>212</small>	Σ <small>228</small>	ƒ <small>244</small>
5	à <small>133</small>	ò <small>149</small>	Ñ <small>165</small>	† <small>181</small>	† <small>197</small>	ƒ <small>213</small>	σ <small>229</small>	Ƶ <small>245</small>
6	Á <small>134</small>	Ú <small>150</small>	ä <small>166</small>	<small>182</small>	† <small>198</small>	π <small>214</small>	μ <small>230</small>	÷ <small>246</small>
7	ç <small>135</small>	ù <small>151</small>	ó <small>167</small>	π <small>183</small>	<small>199</small>	<small>215</small>	τ <small>231</small>	≈ <small>247</small>
8	ê <small>136</small>	î <small>152</small>	¿ <small>168</small>	† <small>184</small>	⌚ <small>200</small>	† <small>216</small>	φ <small>232</small>	° <small>248</small>
9	Ê <small>137</small>	õ <small>153</small>	Ò <small>169</small>	<small>185</small>	ƒ <small>201</small>	Ƶ <small>217</small>	θ <small>233</small>	• <small>249</small>
A	è <small>138</small>	Ü <small>154</small>	¬ <small>170</small>	<small>186</small>	⌚ <small>202</small>	ƒ <small>218</small>	Ω <small>234</small>	• <small>250</small>
B	Í <small>139</small>	ϕ <small>155</small>	½ <small>171</small>	π <small>187</small>	π <small>203</small>	■ <small>219</small>	δ <small>235</small>	√ <small>251</small>
C	Ô <small>140</small>	£ <small>156</small>	¼ <small>172</small>	⌚ <small>188</small>	<small>204</small>	■ <small>220</small>	ω <small>236</small>	n <small>252</small>
D	ì <small>141</small>	Ù <small>157</small>	ì <small>173</small>	⌚ <small>189</small>	= <small>205</small>	<small>221</small>	φ <small>237</small>	² <small>253</small>
E	Ă <small>142</small>	ϖ <small>158</small>	« <small>174</small>	Ƶ <small>190</small>	<small>206</small>	<small>222</small>	ε <small>238</small>	■ <small>254</small>
F	Â <small>143</small>	Ó <small>159</small>	» <small>175</small>	ƒ <small>191</small>	⊥ <small>207</small>	■ <small>223</small>	∩ <small>239</small>	SP <small>255</small>

Page 4 (PC863: Canadian-French)

HEX	8	9	A	B	C	D	E	F
0	Ç 128	É 144	Ì 160	⋮ 176	Ł 192	⍷ 208	ɑ 224	≡ 240
1	Ü 129	È 145	´ 161	⋮ 177	Ł 193	⍷ 209	β 225	± 241
2	é 130	Ê 146	Ó 162	⋮ 178	τ 194	π 210	Γ 226	≥ 242
3	â 131	Ô 147	Ú 163	ı 179	† 195	⍷ 211	π 227	≤ 243
4	Â 132	Ë 148	¨ 164	ı 180	- 196	Ł 212	Σ 228	ƒ 244
5	à 133	Ï 149	˘ 165	ı 181	† 197	ƒ 213	σ 229	Ƶ 245
6	ŋ 134	Û 150	³ 166	ı 182	† 198	π 214	μ 230	÷ 246
7	ç 135	ù 151	ˉ 167	π 183	ı 199	ı 215	τ 231	≈ 247
8	ê 136	α 152	î 168	ı 184	Ł 200	† 216	φ 232	° 248
9	ë 137	ô 153	˘ 169	ı 185	ƒ 201	Ƶ 217	θ 233	• 249
A	è 138	ü 154	˘ 170	ı 186	⍷ 202	ƒ 218	Ω 234	• 250
B	ï 139	ϕ 155	½ 171	ı 187	π 203	■ 219	δ 235	√ 251
C	î 140	£ 156	¼ 172	ı 188	ı 204	■ 220	ω 236	n 252
D	= 141	Û 157	¾ 173	ı 189	= 205	ı 221	φ 237	² 253
E	À 142	Û 158	« 174	Ƶ 190	ı 206	ı 222	ε 238	■ 254
F	§ 143	f 159	» 175	ı 191	Ł 207	■ 223	∩ 239	SP 255

HEX	8	9	A	B	C	D	E	F
0	Ç 128	É 144	á 160	☼ 176	Ł 192	Ɑ 208	ɑ 224	≡ 240
1	Ü 129	æ 145	í 161	☼ 177	Ł̇ 193	Ṛ 209	β 225	± 241
2	é 130	Æ 146	ó 162	☼ 178	Ṛ 194	π 210	Γ 226	≥ 242
3	â 131	ô 147	ú 163	l̇ 179	ł̇ 195	Ɑ 211	π 227	≤ 243
4	ä 132	ö 148	ñ 164	ł̇ 180	– 196	Ł̇ 212	Σ 228	ƒ 244
5	à 133	ò 149	Ñ 165	ł̇ 181	ł̇ 197	Ɔ 213	σ 229	Ƶ 245
6	ã 134	û 150	ã 166	ł̇ 182	ł̇ 198	π 214	μ 230	÷ 246
7	ç 135	ù 151	ȯ 167	π 183	ł̇ 199	ł̇ 215	τ 231	≈ 247
8	ê 136	ÿ 152	ı̇ 168	ł̇ 184	Ł̇ 200	ł̇ 216	ϕ 232	° 248
9	ë 137	ö 153	ı̇ 169	ł̇ 185	Ł̇ 201	Ƶ 217	θ 233	• 249
A	è 138	ü 154	ı̇ 170	ł̇ 186	Ł̇ 202	Ɔ 218	Ω 234	• 250
B	ï 139	ø 155	½ 171	ł̇ 187	Ł̇ 203	■ 219	δ 235	√ 251
C	î 140	£ 156	¼ 172	ł̇ 188	ł̇ 204	■ 220	ω 236	∞ 252
D	ì 141	ø 157	ı̇ 173	ł̇ 189	= 205	■ 221	ϕ 237	² 253
E	Ä 142	Ɔ 158	« 174	ł̇ 190	ł̇ 206	■ 222	ε 238	■ 254
F	Å 143	f 159	Ɑ 175	ł̇ 191	Ł̇ 207	■ 223	∩ 239	SP 255

HEX	8	9	A	B	C	D	E	F
0	€ 128	SP 144	SP 160	° 176	À 192	Ð 208	à 224	ð 240
1	SP 129	‘ 145	ì 161	± 177	Á 193	Ñ 209	á 225	ñ 241
2	, 130	’ 146	¢ 162	² 178	Â 194	Ò 210	â 226	ò 242
3	f 131	“ 147	£ 163	³ 179	Ã 195	Ó 211	ã 227	ó 243
4	” 132	” 148	¤ 164	´ 180	Ä 196	Ô 212	ä 228	ô 244
5	… 133	• 149	¥ 165	µ 181	Å 197	Õ 213	å 229	õ 245
6	† 134	- 150	¦ 166	¶ 182	Æ 198	Ö 214	æ 230	ö 246
7	‡ 135	- 151	§ 167	· 183	Ç 199	× 215	ç 231	÷ 247
8	^ 136	~ 152	¨ 168	¸ 184	È 200	Ø 216	è 232	ø 248
9	‰ 137	™ 153	© 169	¹ 185	É 201	Ù 217	é 233	ù 249
A	Š 138	š 154	ª 170	º 186	Ê 202	Ú 218	ê 234	ú 250
B	‹ 139	› 155	« 171	» 187	Ë 203	Û 219	ë 235	û 251
C	Œ 140	œ 156	¬ 172	¼ 188	Ì 204	Ü 220	ì 236	ü 252
D	SP 141	SP 157	- 173	½ 189	Í 205	Ý 221	í 237	ý 253
E	Ž 142	ž 158	® 174	¾ 190	Î 206	Þ 222	î 238	þ 254
F	SP 143	ÿ 159	- 175	¿ 191	Ï 207	ß 223	ï 239	ÿ 255

HEX	8	9	A	B	C	D	E	F
0	А 128	Р 144	а 160	⌘ 176	Л 192	щ 208	р 224	Ё 240
1	Б 129	С 145	б 161	⌘ 177	л 193	т 209	с 225	ё 241
2	В 130	Т 146	в 162	⌘ 178	т 194	п 210	т 226	ё 242
3	Г 131	У 147	г 163	І 179	ѣ 195	ц 211	у 227	е 243
4	Д 132	Ф 148	д 164	† 180	— 196	ѣ 212	ф 228	ї 244
5	Е 133	Х 149	е 165	‡ 181	† 197	ѣ 213	х 229	ї 245
6	Ж 134	Ц 150	ж 166	‡ 182	‡ 198	п 214	ц 230	ў 246
7	З 135	Ч 151	з 167	п 183	‡ 199	‡ 215	ч 231	ў 247
8	И 136	Ш 152	и 168	ѣ 184	ц 200	‡ 216	ш 232	° 248
9	Й 137	Щ 153	й 169	‡ 185	ѣ 201	Ј 217	щ 233	° 249
A	К 138	Ъ 154	к 170	‡ 186	ц 202	Г 218	ъ 234	° 250
B	Л 139	Ы 155	л 171	п 187	т 203	■ 219	ы 235	√ 251
C	М 140	Ь 156	м 172	ц 188	‡ 204	■ 220	ь 236	No 252
D	Н 141	Э 157	н 173	щ 189	= 205	■ 221	э 237	ѣ 253
E	О 142	Ю 158	о 174	Ј 190	‡ 206	■ 222	ю 238	■ 254
F	П 143	Я 159	п 175	т 191	ц 207	■ 223	я 239	SP 255

HEX	8	9	A	B	C	D	E	F
0	Ç 128	É 144	á 160	⌘ 176	Ł 192	đ 208	Ó 224	- 240
1	ü 129	Í 145	í 161	⌘ 177	Ł 193	Đ 209	β 225	˘ 241
2	é 130	Í 146	ó 162	⌘ 178	τ 194	Đ 210	ô 226	• 242
3	â 131	ô 147	ú 163	ı 179	† 195	Ë 211	Ń 227	ˇ 243
4	ä 132	ö 148	Ą 164	ı 180	- 196	đ 212	ń 228	˘ 244
5	û 133	Ĺ 149	ą 165	Á 181	† 197	Ň 213	ň 229	§ 245
6	ć 134	ĩ 150	ž 166	Â 182	Ǻ 198	Í 214	š 230	÷ 246
7	ç 135	ś 151	ž 167	Ě 183	ǻ 199	Î 215	š 231	• 247
8	ł 136	ś 152	Ę 168	Š 184	Ł 200	ě 216	Ř 232	° 248
9	ë 137	ö 153	ę 169	Ħ 185	Ɔ 201	Ј 217	Ú 233	¨ 249
A	õ 138	ü 154	€ 170	186	Ł 202	Г 218	ř 234	˙ 250
B	õ 139	ř 155	ž 171	ŋ 187	π 203	■ 219	Ů 235	ů 251
C	î 140	ť 156	č 172	Ɔ 188	Ɔ 204	■ 220	ý 236	ř 252
D	ž 141	ł 157	š 173	ž 189	= 205	Ј 221	ý 237	ř 253
E	Ǻ 142	× 158	« 174	ž 190	Ɔ 206	Ů 222	ť 238	■ 254
F	Ć 143	č 159	» 175	ı 191	ǻ 207	■ 223	˘ 239	SP 255

HEX	8	9	A	B	C	D	E	F
0	Ç <small>128</small>	É <small>144</small>	á <small>160</small>	☼ <small>176</small>	Ł <small>192</small>	ð <small>208</small>	Ó <small>224</small>	- <small>240</small>
1	ü <small>129</small>	æ <small>145</small>	í <small>161</small>	☼ <small>177</small>	Ł <small>193</small>	Ð <small>209</small>	β <small>225</small>	± <small>241</small>
2	é <small>130</small>	Æ <small>146</small>	ó <small>162</small>	☼ <small>178</small>	Ƨ <small>194</small>	Ê <small>210</small>	Ô <small>226</small>	= <small>242</small>
3	â <small>131</small>	ô <small>147</small>	ú <small>163</small>	l <small>179</small>	† <small>195</small>	Ë <small>211</small>	ò <small>227</small>	$\frac{3}{4}$ <small>243</small>
4	ä <small>132</small>	ö <small>148</small>	ñ <small>164</small>	l <small>180</small>	- <small>196</small>	È <small>212</small>	õ <small>228</small>	¶ <small>244</small>
5	à <small>133</small>	ò <small>149</small>	Ñ <small>165</small>	Á <small>181</small>	† <small>197</small>	€ <small>213</small>	õ <small>229</small>	§ <small>245</small>
6	ã <small>134</small>	û <small>150</small>	ä <small>166</small>	Â <small>182</small>	ã <small>198</small>	Í <small>214</small>	μ <small>230</small>	÷ <small>246</small>
7	ç <small>135</small>	ù <small>151</small>	o <small>167</small>	À <small>183</small>	Ǻ <small>199</small>	Î <small>215</small>	þ <small>231</small>	· <small>247</small>
8	ê <small>136</small>	ÿ <small>152</small>	¿ <small>168</small>	© <small>184</small>	Ł <small>200</small>	Ï <small>216</small>	þ <small>232</small>	° <small>248</small>
9	ë <small>137</small>	ö <small>153</small>	® <small>169</small>	¶ <small>185</small>	Ɔ <small>201</small>	Ɔ <small>217</small>	Ú <small>233</small>	¨ <small>249</small>
A	è <small>138</small>	ü <small>154</small>	¬ <small>170</small>	¶ <small>186</small>	Ł <small>202</small>	Ɔ <small>218</small>	Û <small>234</small>	· <small>250</small>
B	ï <small>139</small>	ø <small>155</small>	$\frac{1}{2}$ <small>171</small>	¶ <small>187</small>	Ɔ <small>203</small>	■ <small>219</small>	Ü <small>235</small>	¹ <small>251</small>
C	î <small>140</small>	£ <small>156</small>	$\frac{1}{4}$ <small>172</small>	¶ <small>188</small>	Ɔ <small>204</small>	■ <small>220</small>	Ý <small>236</small>	³ <small>252</small>
D	ì <small>141</small>	Ø <small>157</small>	ì <small>173</small>	¢ <small>189</small>	= <small>205</small>	¡ <small>221</small>	Ý <small>237</small>	² <small>253</small>
E	Ä <small>142</small>	× <small>158</small>	« <small>174</small>	¥ <small>190</small>	¶ <small>206</small>	Ï <small>222</small>	¯ <small>238</small>	■ <small>254</small>
F	Å <small>143</small>	f <small>159</small>	» <small>175</small>	₱ <small>191</small>	α <small>207</small>	■ <small>223</small>	˘ <small>239</small>	SP <small>255</small>

Page 254 (User-Defined Page)

The page 254 is available only for slip printing* (except for the endorsement font).

Spaces are defined for the font A.

The following fonts are defined for the font B as default. (Character structure: 7 × 7)

*: For endorsement printing, available only when the 40 cpl mode is disabled.

HEX	8	9	A	B	C	D	E	F
0	SP 128	Ö 144	SP 160	0 176	@ 192	P 208	· 224	p 240
1	ð 129	µ 145	! 161	1 177	A 193	Q 209	a 225	q 241
2	Ð 130	þ 146	" 162	2 178	B 194	R 210	b 226	r 242
3	Ê 131	Þ 147	# 163	3 179	C 195	S 211	c 227	s 243
4	Ë 132	Ú 148	\$ 164	4 180	D 196	T 212	d 228	t 244
5	È 133	Û 149	% 165	5 181	E 197	U 213	e 229	u 245
6	Í 134	Ü 150	& 166	6 182	F 198	V 214	f 230	v 246
7	Î 135	Ý 151	' 167	7 183	G 199	W 215	g 231	w 247
8	Ï 136	Ý 152	(168	8 184	H 200	X 216	h 232	x 248
9	Ì 137	± 153) 169	9 185	I 201	Y 217	i 233	y 249
A	Ó 138	÷ 154	* 170	: 186	J 202	Z 218	j 234	z 250
B	β 139	· 155	+ 171	; 187	K 203	[219	k 235	{ 251
C	Ô 140	SP 156	, 172	< 188	L 204	\ 220	l 236	 252
D	Ò 141	SP 157	- 173	= 189	M 205] 221	m 237	} 253
E	SP 142	SP 158	. 174	> 190	N 206	^ 222	n 238	~ 254
F	ö 143	SP 159	/ 175	? 191	O 207	_ 223	o 239	· 255

Page 255 (User-Defined Page)

Spaces are defined for the font A and endorsement font of slip printing and the font A and font B of receipt printing.

The following fonts are defined for the font B of slip printing as default. (Character structure: 7 × 7)

HEX	8	9	A	B	C	D	E	F
0	Ç 128	É 144	á 160	· 176	· 192	H 208	SP 224	SP 240
1	ü 129	æ 145	í 161	· 177	· 193	I 209	SP 225	SP 241
2	é 130	Æ 146	ó 162	· 178	· 194	SP 210	SP 226	SP 242
3	â 131	ô 147	ú 163	· 179	· 195	SP 211	SP 227	SP 243
4	ä 132	ö 148	ñ 164	· 180	· 196	SP 212	SP 228	SP 244
5	à 133	ò 149	Ñ 165	Á 181	· 197	SP 213	SP 229	SP 245
6	å 134	û 150	Ǧ 166	Â 182	â 198	· 214	SP 230	SP 246
7	ç 135	ù 151	ǧ 167	À 183	Ä 199	· 215	SP 231	SP 247
8	ê 136	ÿ 152	ı 168	İ 184	Ł 200	SP 216	SP 232	SP 248
9	ë 137	Ö 153	· 169	ł 185	ł 201	SP 217	SP 233	SP 249
A	è 138	Ü 154	· 170	ll 186	ll 202	SP 218	SP 234	SP 250
B	ï 139	ø 155	· 171	ł 187	ł 203	SP 219	SP 235	SP 251
C	î 140	£ 156	· 172	ł 188	ł 204	SP 220	SP 236	SP 252
D	ì 141	Ø 157	i 173	ç 189	= 205	SP 221	SP 237	SP 253
E	Ä 142	Ş 158	· 174	· 190	ł 206	SP 222	SP 238	SP 254
F	Å 143	ş 159	α 175	· 191	· 207	SP 223	SP 239	SP 255

International Character Sets

Country	ASCII code (Hex)											
	23	24	40	5B	5C	5D	5E	60	7B	7C	7D	7E
USA	#	\$	@	[\]	^	`	{		}	~
France	#	\$	à	°	ç	§	^	`	é	ù	è	¨
Germany	#	\$	§	Ä	Ö	Ü	^	`	ä	ö	ü	ß
U.K.	£	\$	@	[\]	^	`	{		}	~
Denmark I	#	\$	@	Æ	Ø	Å	^	`	æ	ø	å	~
Sweden	#	¤	É	Ä	Ö	Å	Ü	é	ä	ö	å	ü
Italy	#	\$	@	°	\	é	^	ù	à	ò	è	ì
Spain I	Pt	\$	@	ı	Ñ	ı	^	`	¨	ñ	}	~
Japan	#	\$	@	[¥]	^	`	{		}	~
Norway	#	¤	É	Æ	Ø	Å	Ü	é	æ	ø	å	ü
Denmark II	#	\$	É	Æ	Ø	Å	Ü	é	æ	ø	å	ü
Spain II	#	\$	á	ı	Ñ	ı	é	`	ı	ñ	ó	ú
Latin America	#	\$	á	ı	Ñ	ı	é	ü	ı	ñ	ó	ú
Korea	#	\$	@	[₩]	^	`	{		}	~

