

TM9-1005-229-35

DEPARTMENT OF THE ARMY TECHNICAL MANUAL

DS, GS, AND DEPOT MAINTENANCE MANUAL

INCLUDING REPAIR PARTS AND SPECIAL

TOOLS LISTS FOR

SUBMACHINE GUN, CALIBER .45, M3, W/E

(1005-672-1767)

SUBMACHINE GUN, CALIBER .45, M3A1, W/E

(1005-672-1771)

This copy is a reprint which includes current pages from Change 1.

HEADQUARTERS, DEPARTMENT OF THE ARMY

SEPTEMBER 1969

WARNING

DANGEROUS CONDITIONS

Before starting an inspection, be sure to clear the weapon, Do not actuate the trigger until the weapon has been cleared. Inspect the chamber, to insure that it is empty, and check to see that no ammunition is in position to be introduced (magazine). Avoid having live ammunition in the vicinity of work area.

DANGEROUS SOLUTION

Avoid skin contact with P-C-111. The compound should be washed off thoroughly with running water if it comes in contact with the skin. A good lanolin base cream, after exposure to compound, is helpful. The use of rubber gloves and protective equipment is recommended.

CHANGE

No. 1

Changes in Force: C1

HEADQUARTERS
DEPARTMENT OF THE ARMY
WASHINGTON, DC 2 April 1985

DS, GS, AND DEPOT MAINTENANCE MANUAL
INCLUDING REPAIR PARTS AND SPECIAL TOOLS LISTS

SUBMACHINE GUN, CALIBER .45, M3, W/E
(1005-00-672-1767)

SUBMACHINE GUN, CALIBER .45, M3A1, W/E
(1005-00-672-1771)

TM 9-1005-229-35, 19 September 1969, is changed as follows:

Title is changed as shown above.

Page 3, Paragraph 1-2b, line 8. Change address to read: Commander, US Army Armament, Munitions and Chemical Command, ATTN: AMSMC-MAS, Rock Island, IL 61299-6000.

Page 12, Paragraph 2-14. Change address to read: Commander, US Army Armament, Munitions and Chemical Command, ATTN: AMSMC-MAS, Rock Island, IL 61299-6000.

Page 31, Repair Parts List. Change SMR codes on figure B-7 as follows:

Item 11, CAP from PF to PAOZZ

Item 13, NUT, PLAIN, ROUND from PF to PAOZZ

Item 14, WASHER LOCK from PF to PAOZZ

Item 15, OILER from PF to PAOZZ

By Order of the Secretary of the Army:

JOHN A. WICKHAM, JR.
General, United States Army
Chief of Staff

Official:

DONALD J. DELANDRO
Brigadier General, United States Army
The Adjutant General

Distribution:

To be distributed in accordance with DA Form 12-40, Direct and General Support Maintenance Requirements for Gun, Submachine, Caliber .45, M3, M3A1.

**DS, GS, AND DEPOT MAINTENANCE MANUAL
INCLUDING REPAIR PARTS AND SPECIAL TOOLS LISTS**

SUBMACHINE GUN, CALIBER .45, M3, W/E

(1005-672-1767)

SUBMACHINE GUN, CALIBER .45, M3A1, W/E

(1005-672-1771)

This manual is current as of 10 May 1969.

	Paragraph	Page
CHAPTER 1. INTRODUCTION		
Section I. General -----	1-1-1-2	3
II. Description and data -----	1-3	3
CHAPTER 2. DIRECT SUPPORT, GENERAL SUPPORT AND DEPOT MAINTENANCE INSTRUCTIONS		
SECTION I. Repair parts, special tools, and equipment -----	2-1	7
II. Troubleshooting -----	2-2	8
III. Preembarkation inspections of material in units alerted for overseas movement -----	2-3-2-5	9
IV. General maintenance -----	2-6-2-12	10, 11
V. Removal and installation -----	2-13	11
VI. Depot maintenance procedures -----	2-14	12
CHAPTER 3. REPAIR INSTRUCTIONS -----	3-1-3-5	13-17
CHAPTER 4. FINAL INSPECTION -----	4-14-4	19
APPENDIX A. REFERENCES -----	A-1-A-4	21
APPENDIX B. DIRECT SUPPORT, GENERAL SUPPORT, AND DEPOT MAINTENANCE REPAIR PARTS AND SPECIAL TOOLS LIST		
Section I. Introduction -----	B-1-B-7	23-25
II. Repair Parts List		
Repair Parts For:		
Major groups, assemblies and components (figs B-1 and B-2) -----		26
Bolt and guide rod group (fig B-3) -----		27
Trigger housing group (figs B-4 and B-5) -----		23
Trigger and sear group (fig B-6) -----		29
Receiver assembly (figs. B-7 and B-8) -----		30
Flash hider assembly (fig B-9) -----		32
Oiler (fig B-10) -----		33
III. Special Tools List (fig B-10) -----		34
IV. Index—Federal Stock Number and Reference Number Cross-Reference to Figure and Item Number -----		36

* This manual supersedes TM 9-1005-229-35, 14 December 1964.

CHAPTER 1

INTRODUCTION

Section I. GENERAL

1-1. Scope

These instructions are in accordance with the maintenance allocation chart published for the use of direct support, general support, and depot maintenance personnel maintaining the Caliber .45, Submachine Guns, M3 and M3A1. They provide information on the maintenance of the equipment which is beyond the scope of the tools, equipment, personnel or supplies normally available to the operator and organizational maintenance.

1-2. Forms and Records

a. General. DA forms and procedures used for equipment maintenance will be only those prescribed in TM 38-750, Army Equipment Record Procedures.

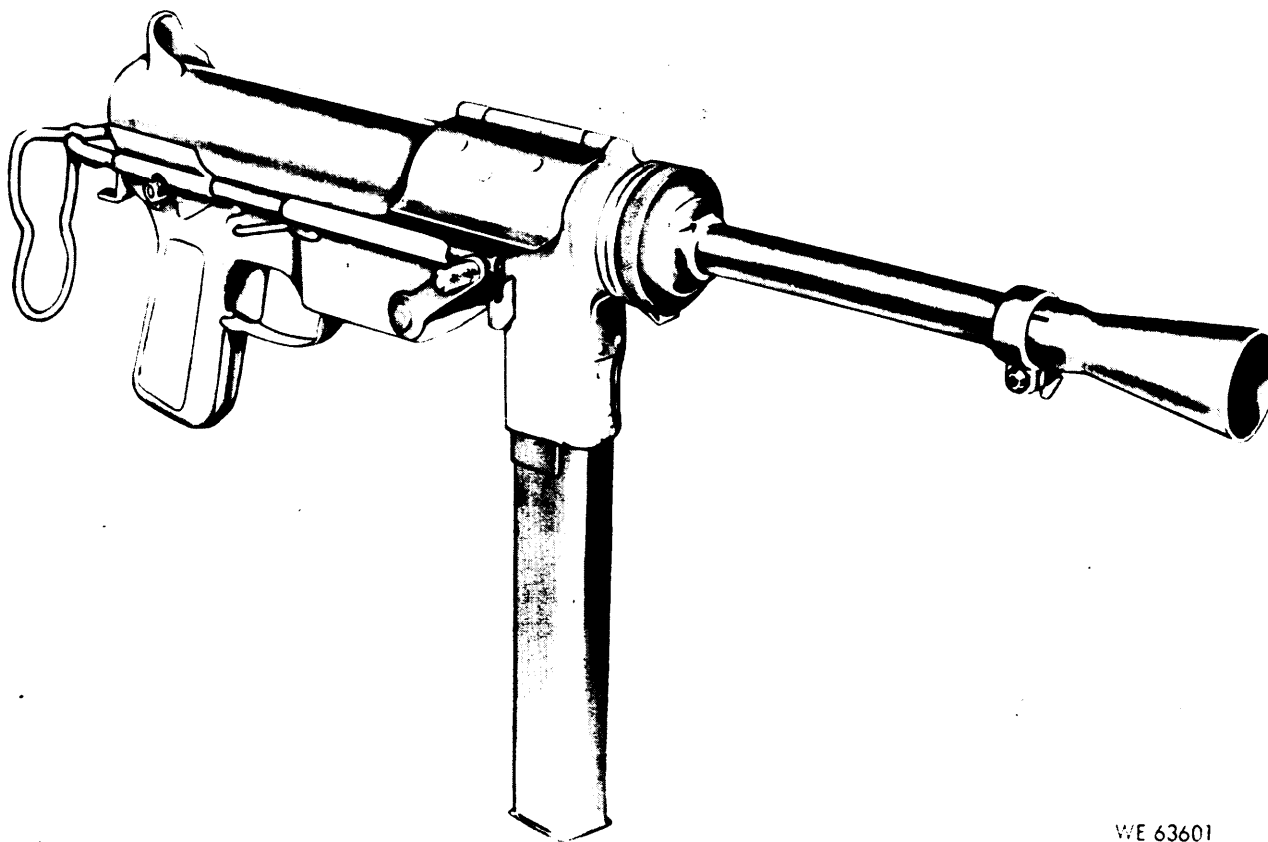
b. Recommendation for Equipment Publication Improvements. Report of errors, omissions, and recommendations for improving this publication by the individual user is encouraged. Reprints should be submitted on DA form 2028 (Recommended Changes to DA Publications) and forwarded direct to: Commanding General, Headquarters, U. S. Army Weapons Command, ATTN: AMSWE-SMM-P, Rock Island, Illinois 61201.

Section II. DESCRIPTION AND DATA

1-3. Description and Tabulated Data

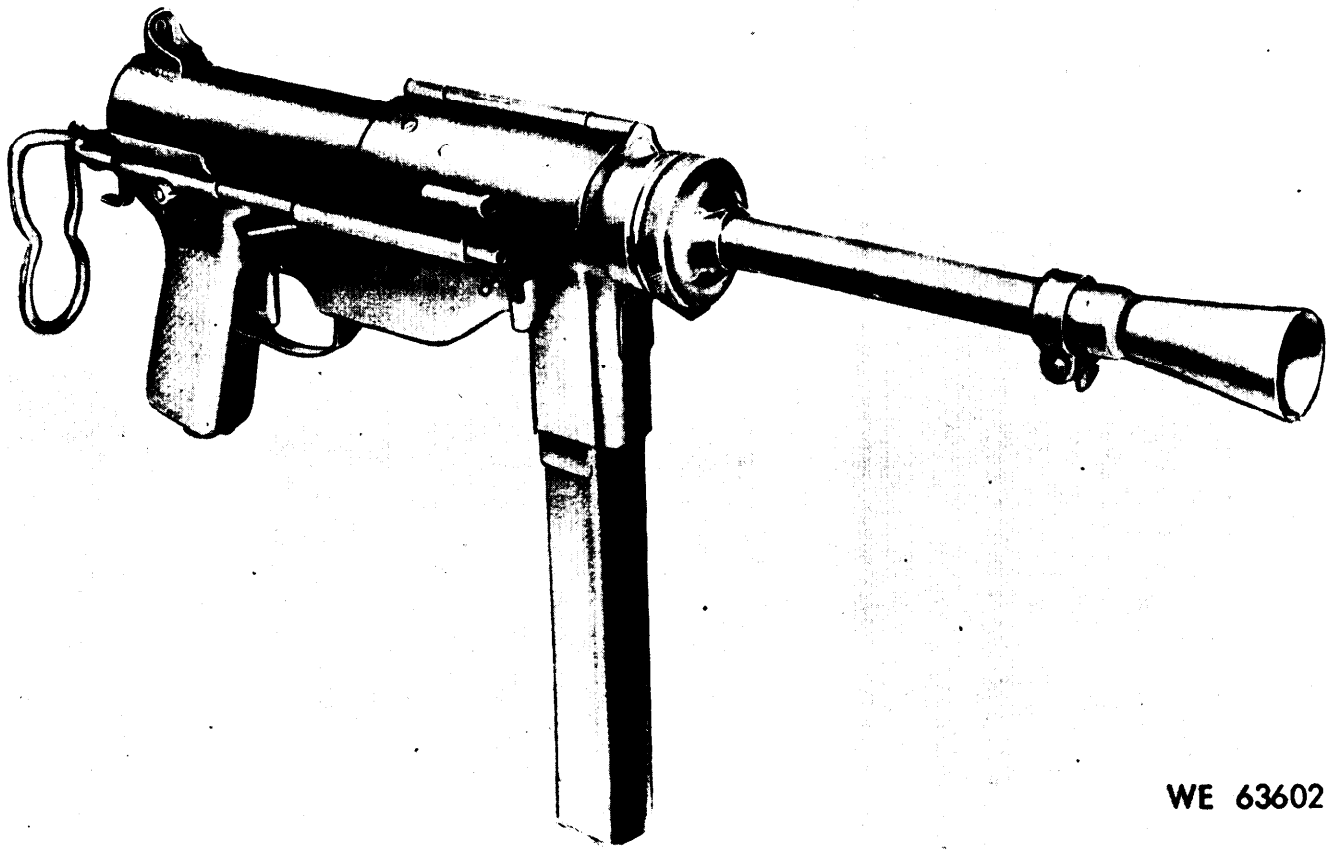
Refer to TM 9-1005-229-12. For overall

views of the submachine gun refer to figures 1-1 and 1-2.



WE 63601

Figure 1-1. Caliber .45 Submachine Gun M3 w/Flash Hider Assembly, M9-right front view.



WE 63602

*Figure 1-2. Caliber .45 Submachine Gun M3A1 w/Flash Hider Assembly,
M9-right front view.*

CHAPTER 2
DIRECT SUPPORT, GENERAL SUPPORT AND
DEPOT MAINTENANCE INSTRUCTIONS

Section I. REPAIR PARTS, SPECIAL TOOLS, AND EQUIPMENT

2-1. Repair Parts, Special Tools and Equipment

Refer to appendix B and table 2-1.

Table 2-1. Special Tools and Equipment

Item	Identifying number	Reference		Use
		Fig	Para	
Trigger pull measuring fixture	7274758	2-1	3-4	To measure trigger pull pressure.

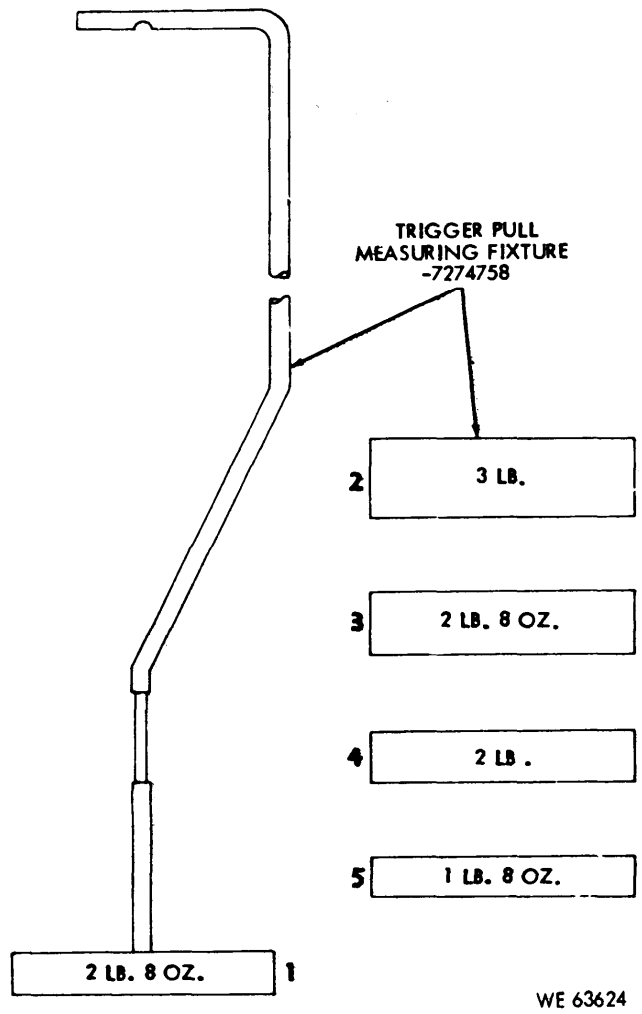


Figure 2-1. Trigger pull measuring fixture.

Section II. TROUBLESHOOTING

2-2. General

Refer to TM 9-1005-229-12 and table 2-2.

Table 2-2. Troubleshooting

Malfunction	Probable cause	Corrective action
1. Failure to feed	Defective magazine catch spring	Replace spring
2. Failure to fire	a. Worn or broken firing pin b. Bent guide rod	a. Replace bolt (6 or 8, fig B-3) b. Straighten guide rod
3. Failure to extract	a. Pitted chamber b. Broken extractor	a. Replace barrel b. Replace extractor

Table 2-2. Troubleshooting—Continued.

Malfunction	Probable cause	Corrective action
4. Failure to eject	Broken ejector	Replace (2, fig B-4 and 12, fig B-5).
5. Failure to cock	Worn sear notch	Replace bolt. (6 or 8, fig B-3)
6. Miscellaneous: Excessive pull required to extract bolt.	a. Dented receiver b. Bent or burned guide rods c. Ejector binding in slot of bolt	a. Repair b. Repair rods. Remove burrs (Para 2-12) c. Repair ejector (table 3-1).
Magazine catch will not depress.	Magazine catch assembled wrong.	Remove and assemble properly.
Difficulty encountered when inserting magazine assembly,	Bent or burned receiver at magazine well.	Remove burrs and straighten.

Section III. PREEMBARKATION INSPECTIONS OF MATERIEL IN UNITS ALERTED FOR OVERSEAS MOVEMENT

2-3. Preparation

a. *Cleaning.* All metal parts shall be thoroughly cleaned (para 2-9). Surfaces of parts subjected to burned powder residue will be cleaned with rifle bore cleaning compound (CR).

b. *Preservation.* All metal surfaces shall be coated with a preservation oil.

2-4. Shipping Instructions

When shipping the submachine gun, the officer-in-charge of preparing the shipment will be responsible for properly processing the materiel for shipment, including the preparation of Army shipping documents.

2-5. Inspection Procedures

Refer to TB 9-1000-247-35 and table 2-3

Table 2-3. Preembarkation Inspection Procedures

Item	Inspection criteria
Barrel	Preliminary Inspection Inspect the weapon as a unit for general appearance and condition
	General Inspection To determine serviceability: A barrel that is uniformly pitted with the edges of the lands sharp is acceptable. Only those barrels showing developed pits, or pits cutting into the lands, are un-

Table 2-3. Preembarkation Inspection Procedures—Continued.

Item	Inspection criteria
	satisfactory. Ringed bores or ringed sufficiently to bulge the outside surface are cause for rejection.
Bolt assembly	Check to see that the bolt slides freely with in the receiver.
Sear assembly	Check to see that the sear holds the bolt firmly in the cocked position and releases the bolt properly when the trigger is actuated.
Safety	With the weapon cocked (the bolt must not move forward as the trigger is squeezed.
Ejector	Check for missing ejector.
Cocking lever	Check the M3 for functioning of the cocking lever.
Oiler	Check the M3A1 to make certain lock washer is present in the oiler.
Components	Inspect for defects in metal components.
	Note. Minor defects in metal components do not normally affect their being acceptable.
Barrel lock	Check functioning of barrel lock.
Miscellaneous	Check to see that all authorized modifications have been applied, and that no unauthorized alterations have been made. Check the index in DA Pam 310-7 and the current MWO files for any MWO's printed after publication.

Table 2-3. Preembarkation Inspection Procedures—Continued.

Item	Inspection criteria
	Make certain that no work beyond the scope of the unit is being attempted. Instruct personnel in proper preventive maintenance procedures, where found inadequate. Check legibility of serial number. Overall

Table 2-3. Preembarkation Inspection Procedures—Continued.

Item	Inspection criteria
Metal surfaces	A worn surface is objectionable from the standpoint of visibility when it is capable of reflecting light. Check to see that all rear sights have a dull black or gray finish on all surfaces.

Section IV. GENERAL MAINTENANCE

2-6. General

This section provides the necessary instructions on the general maintenance procedures. Operating instructions are contained in TM 9-1005-229-12.

2-7. General Repair Methods

a. Disassembly and Assembly Procedures.

(1) In disassembling a unit, remove the major assemblies whenever possible. Subassemblies may be disassembled, as necessary, into individual parts.

(2) During assembly, subassemblies should be assembled first and then install to form a complete unit.

(3) Complete disassembly of a unit is not always necessary in order to make a required repair or replacement. Good judgment should be exercised to keep disassembly and assembly operations to a minimum.

b. Replacement of Parts.

(1) When assembling a unit, replace pins, if damaged. Replace oiler nut or oiler if threads are damaged,

(2) All springs will be replaced if they are broken, bent, cracked, or fail to function properly.

(3) If a required new part is not available, reconditioning of the old part is required. Such parts should be examined carefully after reconditioning to determine their serviceability.

c. Use of Tools.

(1) Care must be exercised to use tools that fit and are suitable for the task to be

performed in water to avoid unnecessary mutilation of parts and/or damage to tools.

(2) Keep tools clean and work with clean parts. Normal rules of good housekeeping must be observed.

2-8. Cleaning

a. After repair operations and prior to assembly, all parts should be cleaned thoroughly of all grease, oil, water and dirt using dry cleaning solvent (SD). They should be dried thoroughly with clean wiping cloths and coated with PL special to prevent rusting.

b. Clean burned powder residues from the barrel bore with rifle bore cleaning compound (CR) using stock extension 7161812 with cleaning brush 5504036. After cleaning with brush place several cleaning rod patches on end of extension and run through bore of barrel several times to clean and dry thoroughly.

c. Clean the chamber using rifle bore cleaning compound (CR) and cleaning brush 610-8828; wipe dry after cleaning.

d. Apply a light coat of general purpose lubrication oil (PL special) to oil exterior surfaces and the bore to prevent corrosion.

e. On components that contain an accumulation of light rust, use a clean cloth moistened with rifle bore cleaning compound (R). If this does not suffice, use crocus cloth. Make certain it does not scratch or alter the finished surfaces. Remove all dirt and residue; oil surfaces before assembling parts.

f. On component parts such as the barrel, bolt and guide rod group, which contain a hard carbon residue it is necessary to clean these items with carbon removing compound, P-C-111, as follows:

Warning. Avoid skin contact. The compound should be washed off thoroughly with running water if it comes in contact with the skin. A good lanolin base cream, after exposure to compound, is helpful. The use of gloves and protective equipment is recommended.

(1) Using a suitable container, fill with fresh compound.

(2) Before soaking a component in compound, remove grease, dirt, and oil. Place parts to be cleaned in container, making certain they are completely immersed.

(3) Soak for 2 to 16 hours. Remove parts and allow to drain. Rinse with water or solvent. To effectively remove carbon, brush with stiff bristle brush under running water. Allow to dry, then apply a light coat of general purpose lubricating oil (PL special).

g. New materiel and component parts received from storage for immediate use may have heavy accumulations of grease. Remove this residue with waste or clean wiping cloths saturated with dry cleaning solvent (SD). Dry and lubricate as specified in paragraph 2-13

h. For general cleaning instructions on all parts, refer to TM 9-208-1.

2-9. General Precautions in Cleaning

a. Dry cleaning solvent is flammable and should not be used near an open flame. Fire extinguisher should be readily available when using this material. In addition, this material evaporates quickly and has a drying effect on the skin. When used without rubber gloves, it may cause cracks in the skin, and in the case of some individuals, a mild irritation or inflammation. Use only in well-ventilated places.

b. The use of diesel fuel oil, gasoline or benzene (benzol) for cleaning the weapon is prohibited.

c. Store rifle bore cleaning compound (CR) in a warm place, if practical. Do not dilute or add anti freeze.

2-10. Finished Surfaces

All treated surfaces will be refinished to match the appearance of new parts.

Note. Sandblasting is permissible on nonworking surfaces for removal of dirt and rust.

2-11. Removal of Burs From Threads and Working Surfaces

a. During the entire life of the submachine gun, polishing and stoning are necessary to relieve friction and to remove burs caused by usage. Burs on threads and like surfaces should be removed with a fine stone, tap or thread chaser. Burs on such working surfaces as the receiver, guide rods, cam surfaces, and receiver housing area should be removed with a fine stone and polished with crocus cloth.

Caution. Care should be observed to stone evenly and lightly and not remove more metal than absolutely necessary to maintain correct contours. Critical dimensions of parts or assemblies must not be altered in any way that would affect the functioning or interchangeability of parts.

b. Rough spots, scores, galling, and gouges will be smoothed to enable the part to operate normally. The finish of the repaired component will be approximate of the original finish.

2-12. Lubrication

Make certain all parts are cleaned and dried thoroughly and lubricated by applying a light coat of general purpose lubricating oil (PL special).

Section V. REMOVAL AND INSTALLATION

2-13. General

For removal and installation of major

groups and assemblies refer to TM 9-1005-229-12 and figures B-1 and B-2.

Section VI. DEPOT MAINTENANCE PROCEDURES

2-14. General

Depot maintenance procedures are similar to those pertaining to direct and general support maintenance. However, further details on

depot maintenance of this materiel will be furnished by contacting, Commanding General, Headquarters, U. S. Army Weapons Command, ATTN: AMSWE-SMM-SA, Rock Island, Illinois 61201.

CHAPTER 3
REPAIR INSTRUCTIONS

3-1. General

This chapter provides specific instructions for guidance during inspection and repair by direct and general support maintenance of materiel in the hands of troops in the field, in dirt and general support shops, and in alerted units scheduled for oversea duty. Inspections are made for the purpose of: (1) determine the condition of an item as to serviceability, (2) recognizing conditions that would cause failure, (3) assuring proper application of maintenance policies at prescribed levels, and (4) determine the Ability of a unit to accomplish its maintenance and supply mission

3-2. Disassembly/Assembly of Major Groups and Assemblies

a. Magazine Assembly, Barrel and Gun Stock Extension. Refer to TM 9-1005-229-12.

b. Bolt and Guide Rod Group. Refer to figure B-3.

c. Trigger Housing Group. Refer to figures B-4 and B-5.

d. Trigger and Sear Group. Refer to figure B-6.

e. Receiver Assembly. Refer to figures B-7 and B-8.

f. Flush Hider Assembly. Refer to figure B-9.

3-3. Cleaning, Inspection, and Repair Instructions

a. Refer to paragraph 2-9 for cleaning instructions.

b. Refer to table 3-1 for inspection and repair procedures.

c. Complete inspection of all parts is not always necessary, good judgment should be exercised pertaining to the degree of inspection of integral parts within assemblies.

Table 3-1. Inspection and Repair Procedures

Item	Inspection	Repair
Magazine:	<p><i>Note.</i> On the new magazines the base is spot welded to the body and disassembly of the magazine, in this case, is not authorized.</p> <p>Inspect base for deformation or wear.</p> <p>Inspect base for burs.</p> <p>Inspect spring for cracks, weak tension and set.</p> <p>Inspect follower for wear.</p> <p>Inspect follower for burs.</p>	<p>Replace magazine (1, figs B-1 and B-2) if components are worn, broken or damaged.</p> <p>Remove burs as described in paragraph 2-11.</p> <p>Replace magazine (1, figs B-1 and B-2) if spring is cracked, set or tension weak.</p> <p>Replace magazine if follower is worn, broken or damaged.</p> <p>Remove burs as described in paragraph 2-11.</p>

Table 3-1. Inspection and Repair Procedures-Cont.

Item	Inspection	Repair
Gun stock extension:	Inspect the body for dents, cracks, and fit in receiver.	Replace magazine if body is damaged.
	Inspect for deformation and wear.	Replace stock extension (2, figs B-1 and B-2) if damaged.
	Inspect for burs.	Straighten if bent.
Barrel	Examine barrel bore for wear, pits and bulges.	Remove burs.
		Replace barrel (3, figs B-1 and B-2) if lands are worn as to affect the accuracy of the weapon. Replace barrel, if pits are as wide as lands or are more than three-eighths of an inch long.
	Check serrations on barrel collar for wear and damage.	Replace barrel if threads are stripped or if serrations are worn affecting the security of barrel to the receiver.
	Inspect the collar; make certain it is secure to the barrel.	Replace the barrel if collar is not secure. Remove burs as indicated in paragraph 2-11.
Bolt and guide rod group:	Inspect guide rod retaining clip for wear and damage.	Replace worn or damaged retaining clip (1, fig B-3).
	Inspect guide rod locating plate; make certain it is not bent or burred at the holes.	Replace worn or bent locating plates (2, fig B-3).
	Inspect extractor pin for wear and damage.	Replace worn or damaged pin (4, fig B-3).
	Check to see that the extractor is clean and free of carbon, is not worn and does not bind in bolt.	Replace worn or damaged extractor (5, fig B-3).
	Check the bolt for wear and burs. Check the firing pin point; make certain it is not worn as to cause misfiring.	Replace bolts (6 or 8, fig B-3) that contain worn firing pins.
		Replace bolt if sear notch is chipped or worn.
	Inspect the guide rods to see that they are straight, smooth and are secured firmly to the locating plate.	Straighten guide rods if bent.
	Inspect the driving springs for function, cracks and set.	Replace guide rods (9, fig B-3) if rods are not secure to locating plate.
		Replace springs (10, fig B-3) if cracked, weak or set.
	Note. Some bolts 5653429, for the M3 Submachine Gun have the letter "H" stamped on the surface indicating they were of early manufacture and were heat treated to increase the hardness. However, all bolts now in use are serviceable, whether or not they have the letter "H" stamped on the surface.	

Table 3-1. Inspection and Repair Procedures-Cont.

Item	Inspection	Repair
Housing group:	<p>Inspect all parts for damage and wear which might cause malfunction. Inspect for burs, rust, foreign matter in recesses, deformation, and free action with mating parts</p> <p>Inspect housing for deformation and dents.</p> <p>Inspect ejector for looseness, damage, and binding in slot of bolt (M3 only).</p> <p>Function the retracting handle to see that the retracting lever pawl is cammed down and the lever rotated forward is by the action of the retracting lever pawl spring.</p> <p>Inspect the spring for distortion, set, and tension. Check to see that the retracting lever pawl stop is not worn.</p> <p>Inspect the retracting handle for burs, wear, rust, and contacting side of receiver.</p> <p>Inspect the retracting lever spring for function, fracture, and set. Check ends; make certain they are not bent or broken.</p> <p>Inspect the retracting lever pawl spring for bends, distortion, and if it is secure.</p> <p>Inspect the oiler clip of the housing for wear, damage, and looseness of housing.</p>	<p>Replace all broken, worn, and unserviceable parts. Remove burs and rust as indicated in paragraph 2-11.</p> <p>Straighten dents, replace if not repairable,</p> <p>Straighten point of ejector if ejector is bent and binds in bolt.</p> <p>Replace spring (6, fig B-5). Replace lever assembly (4, fig B-5) if pawl stop is worn.</p> <p>Replace if broken or worn; remove burs and rust as indicated in paragraph 2-11.</p> <p>Replace spring (3, fig B-5) if broken, worn or unserviceable.</p> <p>Replace spring (6, fig B-5) if broken, worn or unserviceable.</p> <p>Replace clip (10, fig B-5), if damaged</p>
Trigger and sear group:	<p>Inspect sear for wear and burs.</p> <p>Inspect trigger spring for function, cracks, and set.</p> <p>Inspect the trigger and conector for dents, deformation and functioning. Make certain the connector rotates on the rivet.</p>	<p>Remove burs from sear (paragraph 2-11). Replace sear (2, fig B-6) if worn or cracked.</p> <p>Replace spring (4, fig B-6) if cracked or set or if tension is weak.</p> <p>Remove dents from trigger sear connector; replace (6, fig B-6) if damaged or worn.</p>
Receiver assembly:	<p>Inspect the collar for burs and wear.</p> <p>Inspect the catch for functioning, wear, and damage.</p> <p>Inspect spring for cracks, tension, and set.</p>	<p>Replace collar (2, figs B-7 and B-8) if worn. Remove burs (para 2-11).</p> <p>Replace catch (3, figs B-7 and B-8) if worn or damaged.</p> <p>Replace spring (4, figs B-7 and B-8) if cracked, set or tension is weak.</p>

Table 3-1. Inspection and Repair Procedures-Cont.

Item	Inspection	Repair
Receiver assembly-cont.	<p>Inspect for worn, or bent retaining-pin. Inspect pin for burs and wear.</p> <p>Inspect the cover to see if it operates freely and is secured firmly to recesses, Inspect for loose rivets and make certain the safety is not worn.</p> <p>Inspect the cover spring. Make certain it retains the cover and is not worn, burred and deformed and that it is securely retained by the rivets.</p> <p>Inspect the retaining strap, make certain it is secured to the receiver.</p> <p>Inspect the ratchet spring for tension, retaining action with barrel, and for wear. Check to see that it is riveted securely to the receiver (fig 3-1).</p> <p>Inspect the barrel bushing for damaged or stripped threads.</p> <p>Inspect the weld inside receiver; make certain it does not interfere with the movement of the bolt.</p> <p>Inspect the receiver for dents or cracks.</p>	<p>Replace pin (1, figs B-7 and B-8) if bent or worn.</p> <p>Remove burs (para 2-11), replace if bent or worn.</p> <p>Replace rivets (7, figs B-7 and B-8) on cover assembly if loose.</p> <p><i>Note.</i> To install cover spring, insert the two 1/8 x 3/16 flathead solid rivets, with the heads on the inside of the receiver. Place the cover spring on the rivets and position the receiver on an improvised riveting anvil. Peen the ends of the rivets with a ball peen hammer and drift punch until the ratchet spring is secure.</p> <p>Replace cover spring (8, fig B-7 and 9, fig B-8), if weak or loose on receiver.</p> <p>Replace retaining strap (9, fig B-7 and 10, fig B-8) if loose, broken, or missing.</p> <p>Replace ratchet spring (10, fig B-7 and 11, fig B-8) if cracked or tension is weak. Replace rivets (7, figs B-7 and B-8). To install the ratchet spring (10, fig B-7 and 11, fig B-8) insert two 1/8 x 3/16 flat-head solid rivets, with the heads on the inside of the receiver. Place the ratchet spring on the rivets and position the receiver on the improvised riveting anvil. Peen the ends of the rivets until the ratchet spring is secure.</p> <p>Replace weapon if barrel bushing has stripped threads.</p> <p>Replace weapon if welds interfere with movement of bolt or if cracked.</p> <p>If receiver is bent or dented so as to restrict the movement of the bolt, it will be declared unserviceable.</p>

Table 3-1. Inspection and Repair Procedures-Cont.

Item	Inspection	Repair
Receiver assembly - Cont.	Inspect oiler cap and nut on Submachine Gun M3A1 for wear or stripped threads and the oiler for evidence of leaks or stripped threads.	Replace oiler cap (11, fig B-7) nut (13, fig B-7) if worn or if threads are stripped. Replace oiler (15, fig B-7) if it leaks or has stripped threads.
	Inspect magazine well of receiver for burs or being bent.	Remove burs in receiver well (para 2-11). Replace receiver if dents in magazine well cannot be fixed so as not to impede magazine.
Flash hider assembly:	Inspect the wing nut for stripped threads and damage.	Replace wing nut (1, fig B-9) if threads are stripped or damaged.
	Inspect washer for wear and damage.	Replace washer (2, fig B-9) if worn or damaged.
	Inspect the setscrew for stripped threads, burs and wear.	Replace setscrew (3, fig B-9) if threads are stripped or damaged.
	Inspect the flash hider for dents, deformation, and cracks.	Replace flash hider (6, fig B-9) if cracked or dented.
	Inspect ring of flash hider, make certain it is welded to flash hider.	Replace flash hider (6, fig B-9) if ring is loose on flash hider.

3-4. Trigger Pull Test

After final assembly of the submachine gun, check the trigger pull using trigger pull measuring fixture 7274758 (fig. 2-1) in accordance with instructions indicated below.

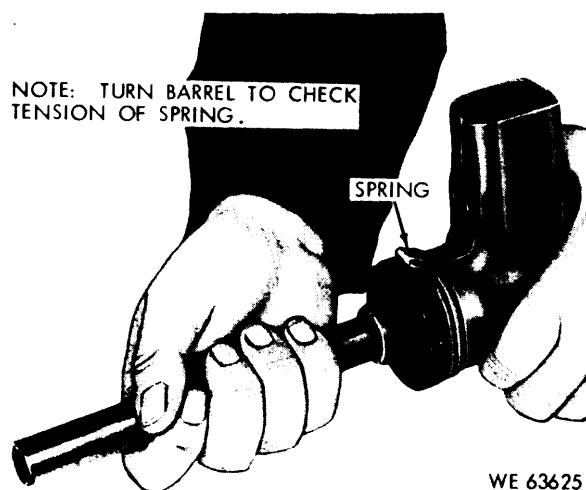


Figure 3-1. Checking spring action of ratchet spring.

Step 1. With the safety unlocked, rest the weight on the floor and hook the notched portion of the rod over the center portion of the trigger.

Note. Make certain the rod does not contact or rub any portion of the submachine gun and that rod and barrel are parallel.

Step 2. Carefully raise the weight from the floor. When using less than the 4 pound weight (minimum), the trigger should not fall. When using the 7.5 pound weight (maximum), the trigger should fall.

Caution. A slow and steady lift must be utilized to assure a true and accurate check.

3-5. Correcting Trigger Pull

Caution. While stoning, critical dimensions should not be altered.

Refer to table 3-2 for trigger pull correction procedures.

Table 3-2. Trigger Pull Correction Procedures

Malfunction	Probable cause	Corrective action
Trigger pull too light	Worn sear	Replace sear (2, fig. B-6).
	Worn sear notch	Replace bolt (6 or 8 fig. B-3).
	Burred sear	Stone sear
Trigger pull too heavy		Replace sear (2, fig B-6).
	Burred sear notch	Stone sear notch on bolt, replace bolt.

CHAPTER 4

FINAL INSPECTION

4-1. General

Final inspection is performed on the materiel, after repair has been completed, to determine that the weapon meets serviceability requirements prescribed in the repair instructions, chapter 3. In performing final inspection, the inspector will make certain that all repairs have been completed and that the weapon is intact and that all components and assemblies are secure and function properly. Listed below are specific inspection procedures to be followed during this inspection.

4-2. Visual Inspection Procedures

- a.* Inspect the magazine, make certain it is retained securely to the gun.
- b.* Inspect the barrel, see that it is secured tightly to the receiver.
- c.* Inspect the hewing group, make certain it is secure to the receiver.
- d.* Check the trigger pin and sear pin, see that they are retaining the trigger and sear group within receiver.
- e.* Inspect sight, make certain it is not bent or distorted.

f. Check over-all appearance of the gun. The metal finish should range from a dense black to a medium light gray. Sight must have a dull black or gray finish.

4-3. Functional Inspection

- a.* Acutate magazine catch for proper function.
- b.* Check functioning of trigger.
- c.* Acutate stock catch, make certain it works in conjunction with stock.
- d.* Function cover assembly, see that it snaps in closed position on receiver and safety holds bolt in locked position.
- e.* Check trigger with trigger pull measuring fixture 7274758 (fig. 2-1). Refer to paragraph 3-4.
- f.* Trigger pull can be corrected by the selective assembly of related parts. Refer to table 3-2.

4-4. Hand Function

Following repair, hand function submachine gun. Weapons which fail to function properly are to be corrected by the replacement of defective component or by performing such repair as required.

APPENDIX A

REFERENCES

A-1. Publication Indexes

The following indexes should be consulted frequently for the latest changes or revisions of references given in this appendix and for new publications relating to materiel covered in this technical manual.

Index of Army Films, Transparencies, GTA Charts, and Recordings	DA Pam 108-1
Military Publications:	
Index of Administrative Publications	DA Pam 310-1
Index of Blank Forms	IDA Pam 310-2
Index of Doctrinal, Training, and Organizational Publications	DA Pam 310-3
Index of Supply Catalogs and Supply Manuals (excluding types 7, 8, and 9)	DA Pam 310-6
Index of Technical Manuals, Technical Bulletins, Supply Manuals (types 7, 8, and 9), Supply Bulletins, and Lubrication Orders	DA Pam 310-4
U.S. Army Equipment Index of Modification Work Orders	DA Pam 310-7

A-2. Supply Catalogs

Tool Set, Direct and General Support Maintenance, Basic Small Arms (FSN 4933-775-0366)	SC 4933-95-CL-E04
Operator's and organizational Maintenance Manual Including Repair Parts and Special Tools List for Submachine Guns, Caliber .45, M3 and M3A1	TM 9-1005-229-12

A-3. Forms

The following form pertains to the materiel.

DA Form 2028, Recommended Changes to DA Technical Manual, Parts List or Supply Manual; 7,8, and 9.

A-4. Other Publications

a. General The following explanatory publications contain information pertinent to this materiel and associated equipment.

Logistics (General):	
Malfunctions Involving Ammunition and Explosives	AR 700-1300-8
Army Equipment Record Procedures	TM 38-750
Military Terms, Abbreviations, and Symbols:	
Authorized Abbreviations and Brevity Codes	AR 320-50
Dictionary of United States Army Terms (short title: AD)	AR 320-5

TM 9-1005-229-35

Military Symbols	FM 21-30
Military Training Management	FM 21-5
Safety: Accident Reporting and Records	AR 385-40
Submachine Guns, Caliber .45, M3 and M3A1	FM 23-41
Techniques of Military Instructions	FM 21-6
<i>b. Inspection and Maintenance.</i>	
Command Maintenance Management Inspections Issue of Supplies and Equipment;	AR 750-8
Requisitioning, Receipt, and Issue System	AR 725-50
Maintenance of Supplies and Equipment:	
Organization, policies, and responsibilities for maintenance operations	AR 750-5
Ordnance Maintenance:	TM 9-208-1
Cleaning of Ordnance Materiel	

APPENDIX B
DIRECT SUPPORT, GENERAL SUPPORT, AND DEPOT
MAINTENANCE REPAIR PARTS AND SPECIAL TOOLS LIST

Section I. INTRODUCTION

B-1. Scope

This appendix lists repair parts and special tools required for the performance of direct support, general support, and depot maintenance of the Caliber .45, Submachine Guns, M3 and M3A1.

B-2. General

This repair parts and special tools list is divided into the following sections:

a. Repair Parts—Section II. A list of repair parts authorized for the performance of maintenance at the direct support, general support, and depot level in figure and item number sequence.

b. Special Tools, Test and Support Equipment—Section III. A list of special tools, test and support equipment authorized for the performance of maintenance at the direct support, general support, and depot level.

c. Federal Stock Number and Reference Number Index—Section IV. A list of Federal stock numbers in ascending numerical sequence followed by a list of referenced numbers in ascending alpha-numeric sequence, cross referenced to the illustration figure number and item number.

B-3. Explanation of Columns

The following provides an explanation of columns in the tabular lists in sections II and III:

a. Source, Maintenance, and Recoverability Codes (SMR), Column 1.

(1) Source codes, indicate the selection status and source for the listed item. Source codes used are:

code	Explanation
P	Repair parts which are stocked in or supplied from the GSA/DSA, or army supply system, and authorized for use at indicated maintenance categories.
P2	Repair parts which are procured and stocked for insurance purposes because the combat or military essentiality of the end item dictates that a minimum quantity be available in the supply system.
M	Repair parts which are not procured or stocked but are to be manufactured at indicated maintenance levels.
A	Assemblies which are not procured or stocked as such but are made up of two or more units. Such component units carry individual FSN'S and descriptions, are procured and stocked separately and can be assembled to form the required assembly at indicated maintenance categories.
X	Parts and assemblies which are not procured or stocked and the mortality of which is normally below that of the applicable end item or component. The failure of such part or assembly should result in retirement of the end item from the supply system.
X1	Repair parts which are not procured or stocked. The requirements for such items will be filled by use of the next higher assembly or component.
X2	Repair parts which are not stocked. The indicated maintenance category requiring such repair parts will attempt to obtain through cannibalization; if not obtainable through cannibalization, such repair parts will be requisitioned with supporting justification through normal channels.
G	Major assemblies that are procured with PEMA funds for initial issue only to be used as exchange assemblies at DSU and GSU level. These assemblies will not be stocked above DSU and GSU level or returned to Depot supply level.

(2) Maintenance codes, indicate the lowest maintenance category authorized to in-

stall the repair part. The maintenance level codes are:

Code	Maintenance Category
C	Operator or Crew
O	Organizational
F	Direct Support
H	General Support
D	Depot

(3) Recoverability codes, indicate whether unserviceable repair parts/or tools and test equipment will be returned for recovery or salvage. Items not coded are expendable. Recoverability codes are:

Code	Recoverability Aspect
R	Applied to repair parts (assemblies and components), special tools and test equipment which are considered economically repairable at Direct and General support maintenance levels. When the item is no longer repairable, it is normally disposed of at the GS level. When supply considerations dictate, some of these repair parts may be listed for automatic return to supply for Depot level repair as set forth in AR 710-50. When so listed, they will be replaced by supply on an exchange basis.
S	Repair parts and assemblies which are economically repairable at DSU and GSU activities and normally are furnished by supply on an exchange basis. When items are determined by a GSU to be uneconomically repairable, they will be evacuated to a depot for evaluation and analysis before final disposition.
T	High dollar value recoverable repair parts which are subject to special handling and are issued on an exchange basis. Such repair parts are normally repaired or overhauled at Depot maintenance activities.
U	Repair parts specifically selected for salvage by reclamation units because of precious metal content, critical materials, high dollar value, reusable casings, or castings.

No Code Indicated Parts will be considered expendable.

b. Federal Stock Number, Column 2. This column indicates the Federal stock number assigned to the item and will be used for requisitioning purposes.

c. Description, Column 3. This column indicates the Federal item name and any additional description of the item required. The abbreviation "w/e" when used as a part of the nomenclature, indicates the Federal stock

number includes all armament, equipment, accessories, and repair parts issued with the item. A part number or other reference number is followed by the applicable five-digit Federal supply code for manufacturers in parentheses.

d. Unit of Measure (U/M), Column 4. A 2 character alphabetic abbreviation indicating the amount or quantity of the item upon which the allowances are based, i.e., ft, ea, pr, etc.

e. Quantity Incorporated in Unit, Column 5. This column indicates the quantity of the item used in a functional group or assembly. A "V" appearing in this column in lieu of a quantity indicates that a definite quantity cannot be indicated (e.g., shims, spacers, etc.).

f. 30-Day DS/GS Maintenance Allowances, Columns 6, and 7.

Note. Allowances in GS column are for GS maintenance only.

(1) The allowance columns are divided into three subcolumns. Indicated in each subcolumn, opposite the first appearance of each item, is the total quantity of items authorized for the number of equipments supported. Subsequent appearances of the same item will have the letters "REF" in the applicable allowance columns. Items authorized for use as required but not for initial stockage are identified with an asterisk in the allowance column.

(2) The quantitative allowances for DS/GS levels of maintenance will represent initial stockage for a 30-day period for the number of equipments supported.

(3) Determination of the total quantity of parts required for maintenance of more than 100 of these equipments can be accomplished by converting the equipment quantity to a decimal factor by placing a decimal point before the next to last digit of the number to indicate hundredths, and multiplying the decimal factor by the parts quantity authorized in the 51-100 allowance column. Example, authorized allowance for 51-100 equipments is 40; for 150 equipments multiply 40 by 1.50 or 60 parts required,

g. 1-Year Allowances Per 100 Equipments/Contingency Planning Purposes, Column 8. This column indicates opposite the first appearance of each item the total quantity re-

quired for distribution and contingency planning purposes. The range of items indicates total quantities of all authorized items required to provide for adequate support of 100 equipments for one year.

h. Depot Maintenance Allowance Per 100 Equipments, Column 9. This column indicates opposite the first appearance of each item, the total quantity authorized for depot maintenance of 100 equipments. Subsequent appearances of the same item will have the letters "REF" in the allowance column. Items authorized for use as required but not for initial stockage are identified with an asterisk in the allowance column.

i. Illustration, Column 10. This column is divided as follows:

(1) *Figure Number, Column 10a.* Indicates the figure number of the illustration in which the item is shown.

(2) *Item Number, Column 10b.* Indicates the callout number used to reference the item in the illustration.

B-4. Special Information

a. Identification of the usable on codes included in column 3 of this publication are:

Code	Used on
No code	M3 and M3A1
A	M3 Only
B	M3A1 Only

b. The following publications pertain to the Submachine Gun, Caliber .45, M3 and M3A1 and their components.

FM 23-41	Submachine Guns, Caliber .45, M3 and M3A1
TM 9-1005-229-12	Operator's and Organizational Maintenance Manual including Basic Issue Items List, Repair Parts and Special Tools List.

B-5. How to Locate Repair Parts

a. When Federal stock number or reference number is unknown:

(1) *First.* Using the table of contents, determine the functional group or assembly within which the repair part belongs. This is necessary since illustrations are prepared for functional groups or assemblies and listings are divided into the same groups.

(2) *Second.* Find the illustration covering the functional group or assembly to which the repair part belongs.

(3) *Third.* Identify the repair part on the illustration and note the illustration figure and item number of the repair part.

(4) *Fourth.* Using the Repair Parts Listing, find the functional group or assembly to which the repair part belongs and locate the illustration figure and item number noted on the illustration.

b. When Federal stock number or reference number is known:

(1) *First.* Using the Index of Federal Stock Numbers and Reference Numbers find the pertinent Federal stock number or reference number. This index is in ascending FSN sequence followed by a list of reference numbers in ascending alpha-numeric sequence, cross-referenced to the illustration figure number and item number.

(2) *Second.* Using the Repair Parts Listing, find the functional group or assembly of the repair part and the illustration figure number referenced in the Index of Federal Stock Numbers and Reference Number.

B-6. Abbreviations

Abbreviations	Explanation
ANLD _____	annealed
CARB _____	carbon
CK _____	countersunk
DLD _____	drilled
FL-HD _____	flat head
ID _____	inside diameter
NC _____	Americal National course thread
NF _____	Americal National fine thread
OD _____	outside diameter
OV,4L-HD _____	oval head
PHOS-CTD _____	phosphate-coated
RD _____	round
S _____	stiel
SHK _____	shank
SYNTH-RBR _____	synthetic rubber

B-7. Federal Supply Codes for Manufacturers

Code	Manufacturer
00000 ----	Ordnance Corps
19204 ----	Rock Island Arsenal
19205 ----	Springfield Armory
81580 ----	McCulloch Corporation
96906 ----	Military Standard

Section II. REPAIR PARTS LIST

(1) Source Maint and Recov Code			(2) Federal Stock No.	(3) Description <i>Reference Number & Mfr Code</i>	(4) Unit of Meas	(5) Qty Inc in Unit	(6) 80-Day DS Maint Allowance			(7) 80-Day GS Maint Allowance			(8) 1- Yr Alw per 100 Equip Cntgty	(9) Depot Maint Alw per 100 Equip	(10) Illustration		
(a) Source	(b) Maint	(c) Recov					<i>Usable on Code</i>	(a) 1-20	(b) 21-50	(c) 51-100	(a) 1-20	(b) 21-50			(c) 51-100	(a) Fig No.	(b) Item No.
P	C	--	1005-565-3427	MAGAZINE, CARTRIDGE 5653427 (19204)	EA	1	2	5	10	2	5	10	120	100	B-1	1	
P	F	--	1005-716-1812	STOCK EXTENSION, GUN: 7161812 (19204)	EA	1	*	2	2	*	2	2	24	10	B-2	1	
P	F	--	1005-986-0261	BARREL, SUBMACHINE GUN: 7791433 (19204)	EA	1	2	2	2	1	2	2	24	20	B-2	2	
A	O	--	-----	HOUSING GROUP	B	--	--	--	--	--	--	--	--	--	B-1	3	
P	O	--	1005-630-1456	GUARD, TRIGGER: 6301456 (19204)	EA	1	2	2	4	2	2	4	48	25	B-2	5	
P	F	--	1005-716-1923	HOUSING ASSEMBLY: 7161923 (19204)	B	EA	1	*	2	*	2	2	24	12	B-1	6	
P	F	--	1005-565-3432	HOUSING ASSEMBLY: 5653432 (19204)	A	EA	1	*	2	*	2	2	24	25	B-2	7	
A	O	--	-----	BOLT AND GUIDE ROD GROUP	B	--	--	--	--	--	--	--	--	--	B-1	4	
A	O	--	-----	BOLT AND GUIDE ROD GROUP	A	--	--	--	--	--	--	--	--	--	B-2	4	
P	F	--	1005-534-9942	HOLDER, SEAR-TRIGGER SPRING: 5349942 (19204)	EA	1	*	2	2	*	2	2	24	10	B-1	8	
P	F	--	5315-535-1190	PIN, STRAIGHT, HEAD- LESS: S, PHOS-CTD, 0.218 IN. MIN. DIA., 0.220 IN. MAX DIA, 5351190 (19204)	EA	1	*	2	2	*	2	2	24	12	B-2	8	
A	O	--	-----	TRIGGER AND SEAR GROUP	--	1	--	--	--	--	--	--	--	--	B-1	9	
															B-2	9	
															B-1	10	
															B-2	10	

Section II. REPAIR PARTS LIST — Continued

(1) Source Maint and Recov Code			(2) Federal Stock No.	(3) Description <i>Reference Number & Mfr Code</i>	(4) Unit of Meas	(5) Qty Inc in Unit	(6) 30-Day DS Maint Allowance			(7) 30-Day GS Maint Allowance			(8) 1-Yr Alw per 100 Equip Cntgcy	(9) Depot Maint Alw per 100 Equip	(10) Illustration		
(a) Source	(b) Maint	(c) Recov					<i>Usable on Code</i>	(a) 1-20	(b) 21-50	(c) 51-100	(a) 1-20	(b) 21-50			(c) 51-100	(a) Fig No.	(b) Item No.
P	O	--	1005-716-0997	SHIELD: 7160997 (19204)	EA	1	2	2	4	2	2	4	48	75	B-1 B-2	12 12	
P	O	--	1005-200-5864	SPRING, HELICAL, COMPRESSION:	EA	1	2	2	4	2	2	4	48	50	B-1 B-2	13 13	
X	--	--	-----	RECEIVER ASSEMBLY 6573936 (19204)	A	--	--	--	--	--	--	--	--	--	B-1	14	
X	--	--	-----	RECEIVER ASSEMBLY 7161930 (19204)	B	--	--	--	--	--	--	--	--	--	B-2	14	
BOLT AND GUIDE ROD GROUP																	
P	O	--	1005-534-9931	CLIP, RETAINING: 5349931 (19205)	EA	1	2	2	4	2	2	4	48	100	B-3	1	
P	O	--	1005-535-1195	PLATE, LOCATING: 5351195 (19204)	EA	2	2	2	2	2	2	2	24	25	B-3	2	
X1	--	--	-----	BOLT ASSEMBLY 6301470 (19204)	A	--	--	--	--	--	--	--	--	--	B-3	3	
P	F	--	5315-534-9935	PIN, SHOULDER, HEAD- LESS: S, CARB, 0.895 IN. LG 5349935 (19204)	EA	1	*	2	2	*	2	2	24	15	B-3	4	
P	O	--	1005-630-1464	EXTRACTOR, CARTRIDGE: 6301464 (19204)	EA	1	2	2	3	2	2	3	36	10	B-3	5	
P	F	--	1005-565-3429	BOLT, BREECH: 5653429 (19204)	A	EA	1	*	2	2	2	2	24	10	B-3	6	
X1	--	--	-----	BOLT ASSEMBLY 7161921 (19204)	B	--	--	--	--	--	--	--	--	--	B-3	7	
P	F	--	1005-716-1926	BOLT, BREECH: 7161926 (19204)	B	EA	1	*	2	2	2	2	24	10	B-3	8	

Section II. REPAIR PARTS LIST — Continued

(1) Source Maint and Recov Code			(2) Federal Stock No.	(3) Description <i>Reference Number & Mfr Code</i>	(4) Unit of Meas	(5) Qty Inc in Unit	(6) 30-Day DS Maint Allowance			(7) 30-Day GS Maint Allowance			(8) 1-Yr Alw per 100 Equip Cntacy	(9) Depot Maint Alw per 100 Equip	(10) Illustration		
(a) Source	(b) Maint	(c) Recov					<i>Usable on Code</i>	(a) 1-20	(b) 21-50	(c) 51-100	(a) 1-20	(b) 21-50			(c) 51-100	(a) Fig No.	(b) Item No.
P	O	--	1005-176-0999	SPRING, HELICAL, COMPRESSION: 7160999 (19204)	EA	2	2	2	3	2	2	3	36	25	B-3	10	
TRIGGER HOUSING GROUP B																	
P	F	--	5320-011-8047	RIVET, SOLID: FL-HD, S, ANLD, 1/8 x 3/16 118047 (19204)	EA	2	2	2	2	2	2	2	24	25	B-4	1	
X1	--	--	-----	EJECTOR, CARTRIDGE 7161918 (19204)	B	1	--	--	--	--	--	--	--	--	B-4	2	
X1	--	--	-----	HOUSING 7161927 (19204)	B	1	--	--	--	--	--	--	--	--	B-4	3	
TRIGGER HOUSING GROUP A																	
P	F	--	5315-013-7155	PIN, COTTER: S, PHOS- CTD, 3/32 DIA, 1/2 LG 137155 (00000)	A HD	1	2	2	2	2	2	2	24	100	B-5	1	
P	F	--	1005-630-1452	HANDLE: 6301452	A EA	1	*	2	2	*	2	2	24	10	B-5	2	
P	F	--	1005-534-9925	SPRING, HELICAL, TORSION: 5349925 (19204)	A EA	1	*	2	2	*	2	2	24	50	B-5	3	
P	F	--	1005-630-1474	LEVER ASSEMBLY: 6301474 (19204)	A EA	1	2	2	2	2	2	2	24	20	B-5	4	
P	F	--	5315-534-9921	PIN, STRAIGHT, THREADED: S, NO. 5- 40NC-2, 0.060 IN. X 0.15 LG THD 5349921 (19204)	A EA	1	2	2	4	2	2	4	48	50	B-5	5	
P	F	--	1005-535-1191	SPRING, HELICAL, TORSION: 5351191 (19204)	A EA	1	2	2	2	2	2	2	24	10	B-5	6	

Section II. REPAIR PARTS LIST — Continued

(1) Source Maint and Recov Code			(2) Federal Stock No.	(3) Description <i>Reference Number & Mfr Code</i>	(4) Unit of Meas	(5) Qty Inc in Unit	(6) 80-Day DS Maint Allowance			(7) 30-Day GS Maint Allowance			(8) 1-Yr Alw per 100 Equip Cntgcy	(9) Depot Maint Alw per 100 Equip	(10) Illustration		
(a) Source	(b) Maint	(c) Recov					<i>Usable on Code</i>	(a)	(b)	(c)	(a)	(b)			(c)	(a) Fig No.	(b) Item No.
								1-20	21-50	51-100	1-20	21-50			51-100		
X1	--	--	-----	LEVER, RETRACTING 5351198 (19204)	A	--	1	--	--	--	--	--	--	B-5	7		
X1	--	--	-----	HOUSING W/EJECTOR ASSEMBLY 6301481 (19204)	A	--	1	--	--	--	--	--	--	B-5	8		
P	F	--	5320-682-1862	RIVET, TUBULAR: OVAL-HD, S, 1/8 x 3/16 (1/16 DLD SHK) MS16535-114 (96906)	A	EA	2	2	2	2	2	24	25	B-5	9		
P	F	--	1005-535-1210	CLIP: 5351210 (19205)	A	EA	1	*	2	2	*	2	2	24	11	B-5	10
P	F	--	5320-011-8047	RIVET, SOLID: FL-HD, S, ANLD, 1/8 x 3/16 118047 (19204)	A	EA	2	REF	REF	REF	REF	REF	REF	REF	REF	B-5	11
X1	--	--	-----	EJECTOR, CARTRIDGE 6301482 (19204)	A	--	1	--	--	--	--	--	--	B-5	12		
X1	--	--	-----	HOUSING 5653433 (19204)	A	--	1	--	--	--	--	--	--	B-5	13		
				TRIGGER AND SEAR GROUP													
P	F	--	5315-534-9938	PIN, STRAIGHT, HEAD- LESS: S, PHOS-CTD, 0.1545 IN. MIN. DIA. 0.1575 IN. MAX. DIA 5349938 (19204)	EA		1	*	2	2	*	2	2	24	20	B-6	1
P	O	--	1005-716-2774	SEAR: 7162774 (19204)	EA		1	*	2	2	*	2	2	24	15	B-6	2
P	F	--	1005-630-1448	TRIGGER: 6301448 (19204)	EA		1	*	2	2	*	2	2	24	20	B-6	3
P	F	--	1005-535-1196	SPRING, HELICAL, EXTENSION: 5351196 (19204)	EA		1	2	2	2	2	2	2	24	60	B-6	4

Section II. REPAIR PARTS LIST — Continued

(1) Source Maint and Recov Code			(2) Federal Stock No.	(3) Description <i>Reference Number & Mfr Code</i>	(4) Unit of Meas	(5) Qty Inc in Unit	(6) 80-Day DS Maint Allowance			(7) 30-Day GS Maint Allowance			(8) 1-Yr Alw per 100 Equip Cntgy	(9) Depot Maint Alw per 100 Equip	(10) Illustration	
(a) Source	(b) Maint	(c) Recov					(a) 1-20	(b) 21-50	(c) 51-100	(a) 1-20	(b) 21-50	(c) 51-100			(a) Fig No.	(b) Item No.
X1	--	--	-----	RIVET, CONNECTOR 5349943 (19204)	--	1	--	--	--	--	--	--	--	B-6	5	
X1	--	--	-----	CONNECTOR, SEAR: 6301450 (19204)	--	1	--	--	--	--	--	--	--	B-6	6	
X1	--	--	-----	TRIGGER: 6301472 (19204)	--	1	--	--	--	--	--	--	--	B-6	7	
RECEIVER ASSEMBLY																
P	F	--	5315-534-9948	PIN, STRAIGHT, HEADED: S, RD, CK, 0.057 IN. MIN. DIA., 0.220 IN. MAX. DIA 5349948 (19204)	EA	1	*	2	2	*	2	2	24	18	B-7	1
P	F	--	1005-534-9947	COLLAR, SHAFT: 5349947 (19205)	EA	1	*	2	2	*	2	2	24	10	B-7	2
P	F	--	1005-534-9927	CATCH: 5349927 (19205)	EA	1	*	2	2	*	2	2	24	16	B-7	3
P	F	--	1005-209-9755	SPRING, HELICAL, COMPRESSION: 5351194 (19204)	EA	1	*	2	2	*	2	2	24	25	B-7	4
P	F	--	5315-716-1906	PIN, GROOVED, HEAD- LESS: S, PHOS-CTD, 0.216 IN. MIN. DIA., 0.220 IN. MAX. DIA. 7161906 (19204)	B EA	1	*	2	2	*	2	2	24	15	B-7	5
P	F	--	1005-716-1922	COVER, RECEIVER: 7161922 (19204)	B EA	1	*	2	2	*	2	2	24	15	B-7	6
P	F	--	5320-011-8047	RIVET, SOLID: FL-HD, S, ANLD, 1/8 x 3/16 118047 (19204)	EA	4	REF	REF	REF	REF	REF	REF	REF	REF	B-7	7
P	F	--	1005-716-1910	SPRING, COVER: 7161910 (19204)	B EA	1	*	2	2	*	2	2	24	20	B-7	8
P	D	--	5340-535-1209	STRAP, RETAINING: 5351209 (19204)	EA	2	--	--	--	--	--	--	--	10	B-7	9

Section II. REPAIR PARTS LIST — Continued

Source	(1) Source Maint and Recov Code			(2) Federal Stock No.	(3) Description <i>Reference Number & Mfr Code</i>	(4) Unit of Meas	(5) Qty Inc in Unit	(6) 80-Day DS Maint Allowance			(7) 30-Day GS Maint Allowance			(8) 1-Yr Alw per 100 Equip Cntgcy	(9) Depot Maint Alw per 100 Equip	(10) Illustration	
	(a)	(b)	(c)					(a)	(b)	(c)	(a)	(b)					
	Maint	Recov						1-20	21-50	51-100	1-20	21-50	51-100			Fig No.	Item No.
P	F	--	1005-716-1935	SPRING: 7161935 (19204)		EA	1	*	2	2	*	2	2	24	5	B-7	10
P	F	--	1005-716-1913	CAP: 7161913 (19204)	B	EA	1	*	2	2	*	2	2	24	10	B-7	11
P	O	--	1005-716-1911	GASKET: SYNTH-RBR, 0.490 OD, 0.290 ID, 0.060 THK 7161911 (19204)	B	EA	1	2	2	4	2	2	4	48	100	B-7	12
P	F	--	5310-716-1905	NUT, PLAIN, ROUND: S, PHOS-CTD, 7/16 20NF-2, 0.090 IN. THK 7161905 (19204)	B	EA	1	*	2	2	*	2	2	24	10	B-7	13
P	F	--	5310-261-7161	WASHER LOCK: 101836 (81580)	B	HD	1	*	2	2	*	2	2	24	15	B-7	14
P	F	--	1005-731-2910	OILER: 7312910 (19204)		EA	1	*	2	2	*	2	2	24	10	B-7	15
X	--	--	-----	RECEIVER, W/O COVER ASSY 7161931 (19204)	B	--	1	--	--	--	--	--	--	--	--	B-7	16
				RECEIVER ASSEMBLY													
P	F	--	5315-534-9948	PIN, STRAIGHT, HEADED: S, RD, CK, 0.057 IN. MIN DIA, 0.060 IN. MAX DIA 5349948 (19204)		EA	1	*	2	2	*	2	2	24	18	B-8	1
P	F	--	1005-534-9947	COLLAR, SHAFT: 5349947 (19205)		EA	1	*	2	2	*	2	2	24	10	B-8	2
P	F	--	1005-534-9927	CATCH: 5349927 (19205)		EA	1	*	2	2	*	2	2	24	16	B-8	3
P	F	--	1005-209-9755	SPRING, HELICAL, COMPRESSION: 5351194 (19204)		EA	1	*	2	2	*	2	2	24	25	B-8	4

Section II. REPAIR PARTS LIST — Continued

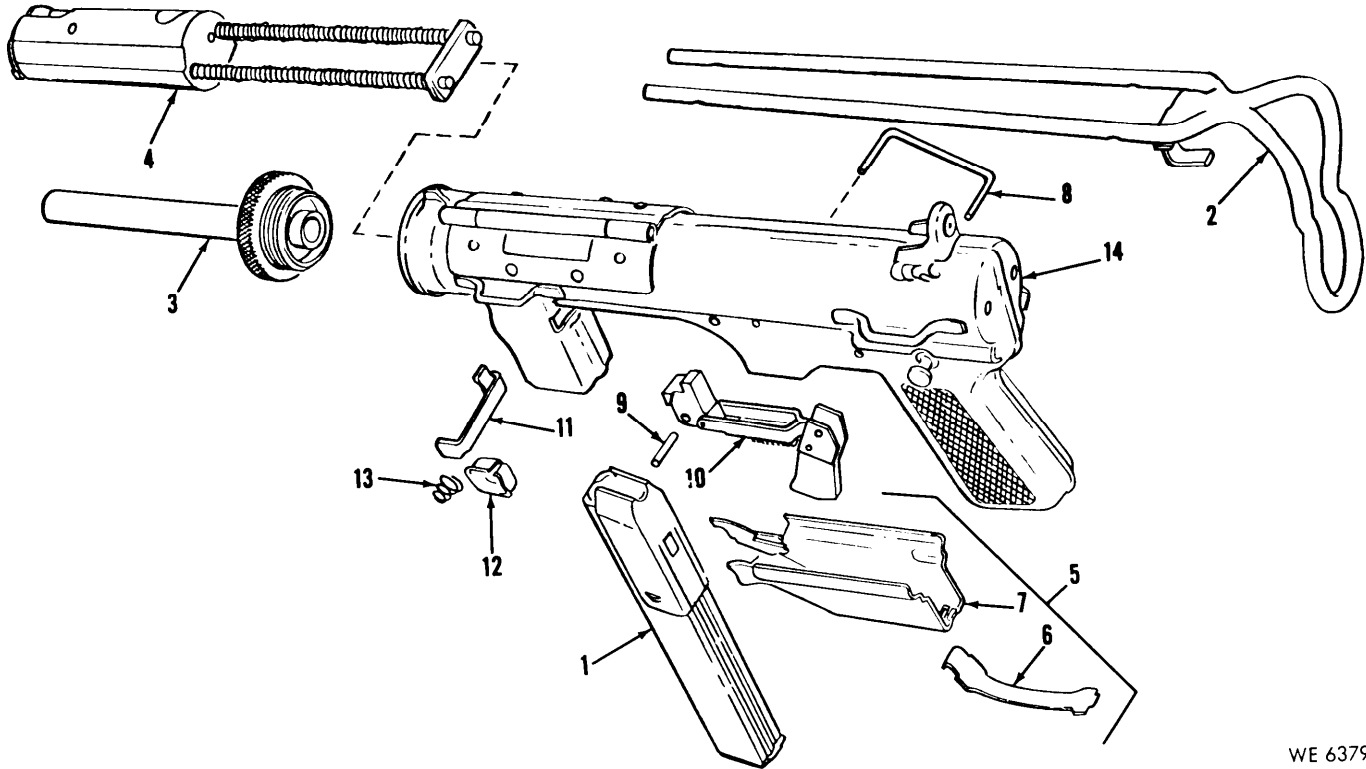
(1) Source Maint and Recov Code			(2) Federal Stock No.	(3) Description <i>Reference Number & Mfr Code</i>	(4) Unit of Meas	(5) Qty Inc in Unit	(6) 30-Day DS Maint Allowance			(7) 30-Day GS Maint Allowance			(8) 1-Yr Alw. per 100 Equip Cntgcy	(9) Depot Maint Alw per 100 Equip	(10) Illustration	
(a) Source	(b) Maint	(c) Recov					(a) 1-20	(b) 21-50	(c) 51-100	(a) 1-20	(b) 21-50	(c) 51-100			(a) Fig No.	(b) Item No.
X1	--	--	-----	HIDER W/RING ASSEMBLY 7625629 (19204)	--	1	--	--	--	--	--	--	--	B-9	6	
				OILER												
X1	--	--	-----	TUBE 5196480 (19204)	A	1	--	--	--	--	--	--	--	B-10	10	
P	O	--	1005-519-6456	GASKET: SYNTH-RBR, 0.200 ID, 0.383 OD, 0.060 THK 5196456 (19204)	EA	1	2	4	7	2	4	7	84	B-10	11	
X1	--	--	-----	CAP 5196481 (19204)	A	1	--	--	--	--	--	--	--	B-10	12	

Section III. SPECIAL TOOLS LIST

(1) Source Maint and Recov Code			(2) Federal Stock No.	(3) Description <i>Reference Number & Mfr Code</i>	(4) Unit of Meas	(5) Qty Inc in Unit	(6) 30-Day DS Maint Allowance			(7) 30-Day GS Maint Allowance			(8) 1-Yr Alw per 100 Equip Cntgy	(9) Depot Maint Alw Per 100 Equip	(10) Illustration	
(a) Source	(b) Maint	(c) Recov					(a) 1-20	(b) 21-50	(c) 51-100	(a) 1-20	(b) 21-50	(c) 51-100			(a) Fig No.	(b) Item No.
TOOLS AND EQUIPMENT FOR UNIT REPLACEMENT																
			1005-288-3565	SWAB, SMALL ARMS CLEANING: COTTON 2-½ SQ (1000 IN PKG) 5019316 (19204)	PG		2	2	2	2	2	2	24	B-10	8	
			1005-555-7152	SLING, SMALL ARMS: 5557152 (19204)	EA		2	2	4	2	2	4	48	B-10	3	
			1005-555-9738	BAG: CANVAS SPARE PARTS 5559738 (19204)	EA		*	*	2	*	*	2	24	B-10	1	
			1005-556-4364	OILER, CARBINE: 5564364 (19204)	A EA		2	2	2	2	2	2	24	B-10	9	
			1005-565-3431	FILLER, MAGAZINE: M1 5653431 (19204)	A EA		*	2	2	*	2	2	24	B-10	4	
			1005-550-4036	BRUSH, CLEANING, SMALL ARMS: M5, BORE 5504036 (19204)	EA		2	2	2	2	2	2	24	—	—	
			1005-610-8828	BRUSH, CLEANING, SMALL ARMS: M6 CHAMBER 6108828 (19204)	EA		2	3	5	2	3	5	60	B-10	13	
			1005-722-8907	ENVELOPE: FABRIC, 2 BUTTON, 4-7/8 x 3 7228907 (19204)	EA		*	*	2	*	*	2	24	B-10	2	
			1005-726-5628	FLASH HIDER ASSEMBLY: 7265628 (19204)	EA		1	2	3	1	2	3	24	B-10	5	
			1005-726-5879	CAP, MAGAZINE: 7265879 (19204)	EA		2	5	10	2	5	10	120	B-10	6	
			4933-726-6175	TOOL, REMOVER, EXTRACTOR PIN: 7266175 (19204)	EA		*	2	2	*	2	2	24	B-10	7	

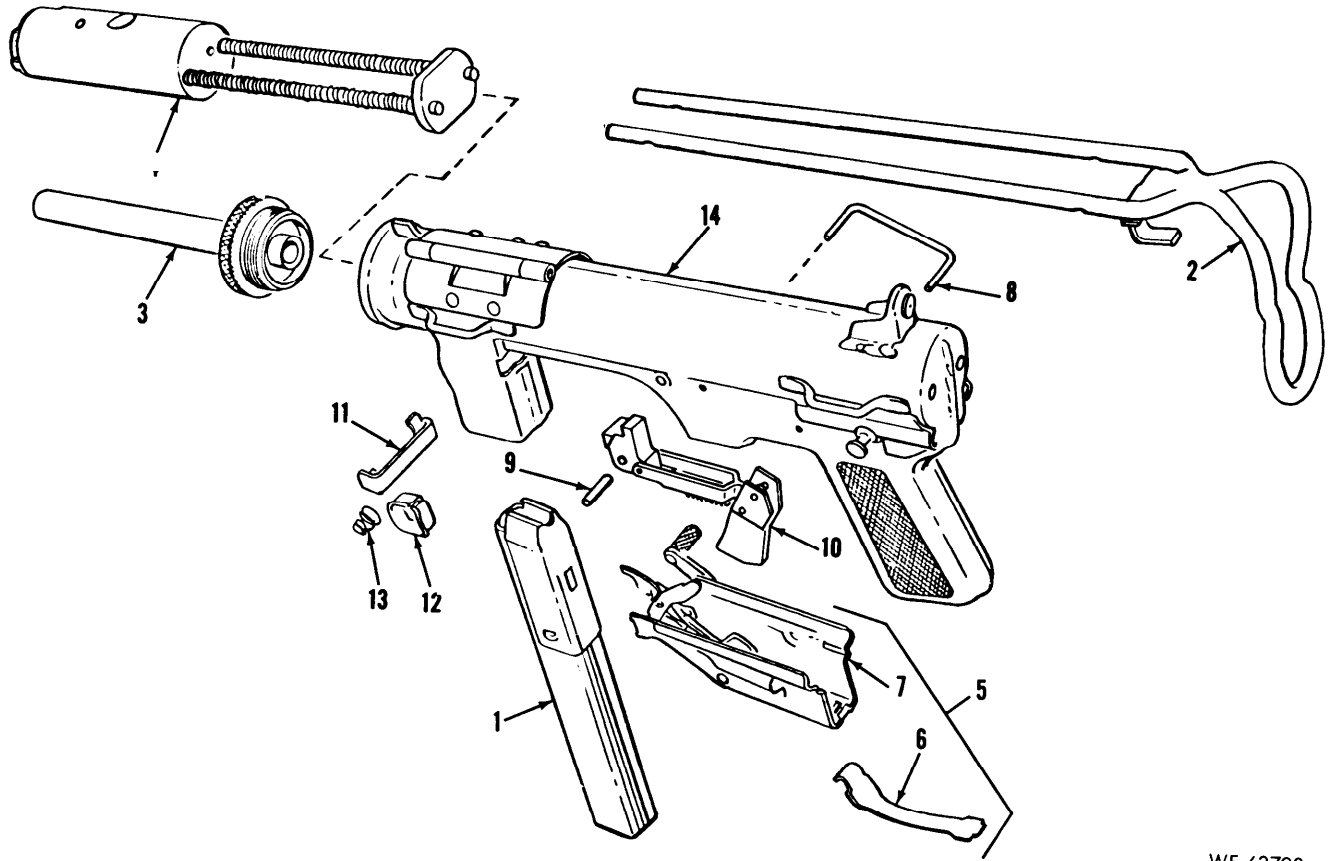
Section III. SPECIAL TOOLS LIST

(1) Source Maint and Recov Code			(2) Federal Stock No.	(3) Description <i>Reference Number & Mfr Code</i>	(4) Unit of Meas	(5) Qty Inc in Unit	(6) 30-Day DS Maint Allowance			(7) 30-Day GS Maint Allowance			(8) 1-Yr Alw per 100 Equip Catecy	(9) Depot Maint Alw per 100 Equip	(10) Illustration	
(a) Source	(b) Maint	(c) Recov					(a) 1-20	(b) 21-50	(c) 51-100	(a) 1-20	(b) 21-50	(c) 51-100			(a) Fig No.	(b) Item No.
P	F	R					4933-775-0366	<p>TOOLS AND EQUIPMENT</p> <p>THE 15 DAY LEVEL DOES NOT APPLY</p> <p>THE FOLLOWING BASIC SMALL ARMS DIRECT AND GENERAL SUPPORT MAINTENANCE TOOL SET IS AUTHORIZED AS REQUIRED, TO ALL MAINTENANCE SUPPORT UNITS WITH A SMALL ARMS REPAIR MISSION.</p> <p>TOOL SET, DIRECT AND GENERAL SUPPORT MAINTENANCE BASIC SMALL ARMS: 8426358 (19204)</p> <p>NOTE: SEE SC 4933-95-CL-E04 FOR COMPONENTS</p>	EA	--	*	*			*	*



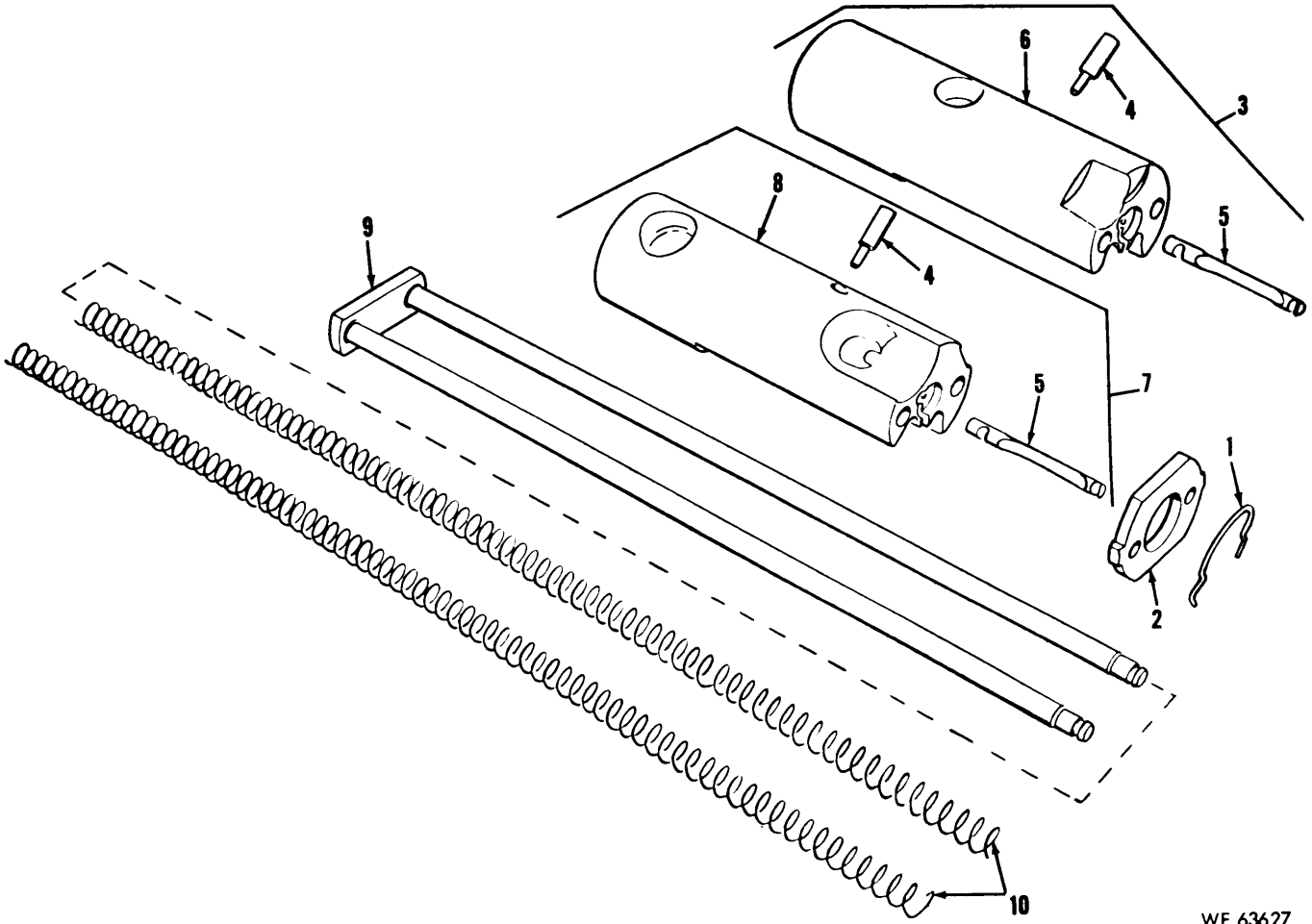
WE 63791

Figure B-1. Submachine Gun, Caliber .45, M3A1 only- major groups, assemblies and components.



WE 63790

Figure B-2. Submachine Gun, Caliber .45, M3 only-major groups, assemblies and component.



WE 63627

Figure B-3. Bolt and guide rod group, M3 and M3A1-exploded view.

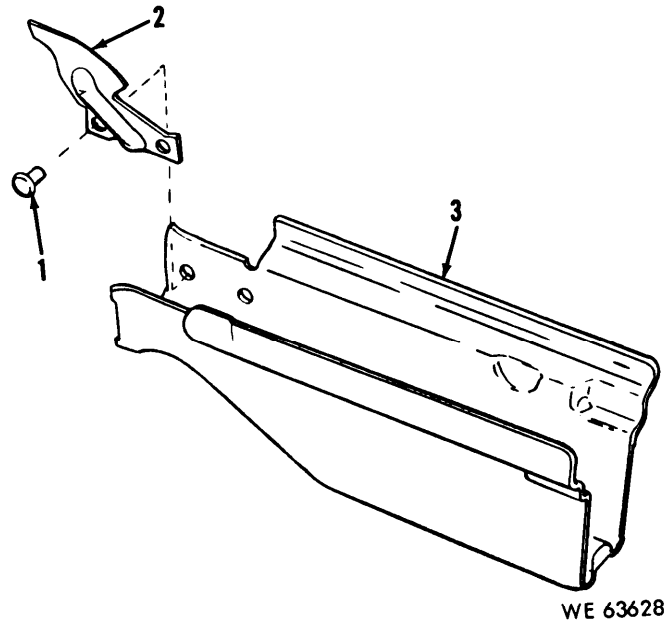
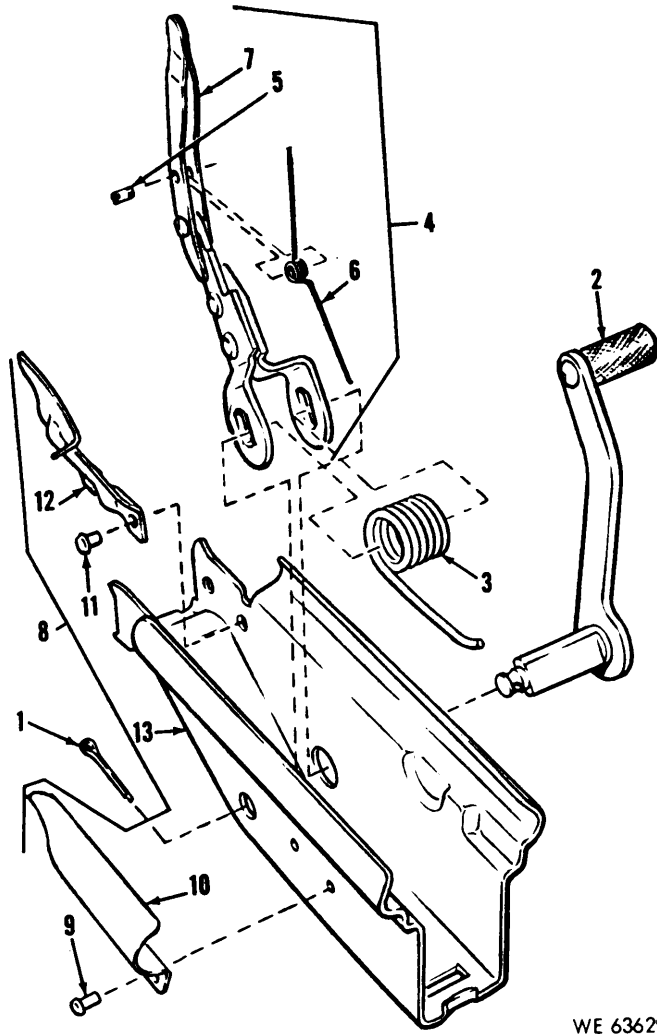
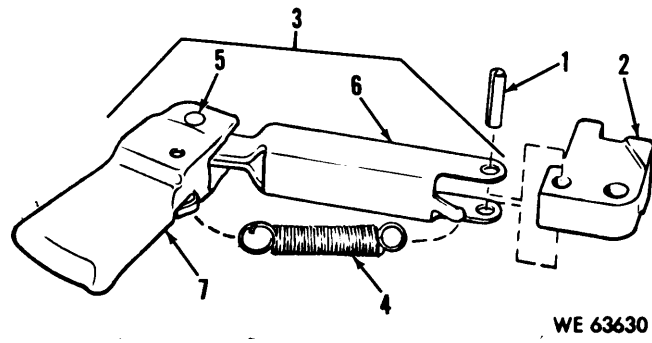


Figure B-4. Trigger housing group, M3A1 only-
exploded view.

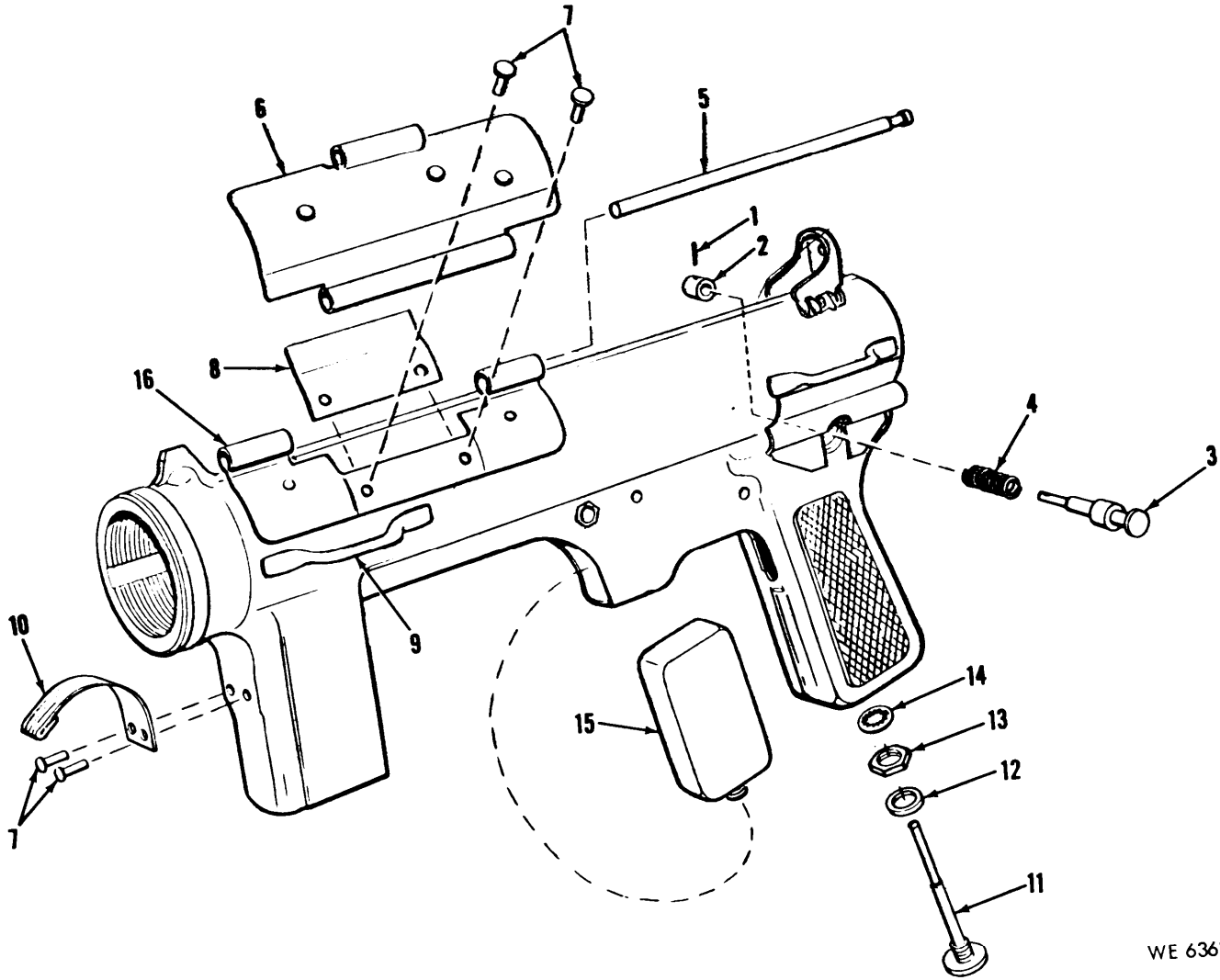


WE 63629

*Figure B-5. Trigger housing group, M3 only—
exploded view.*

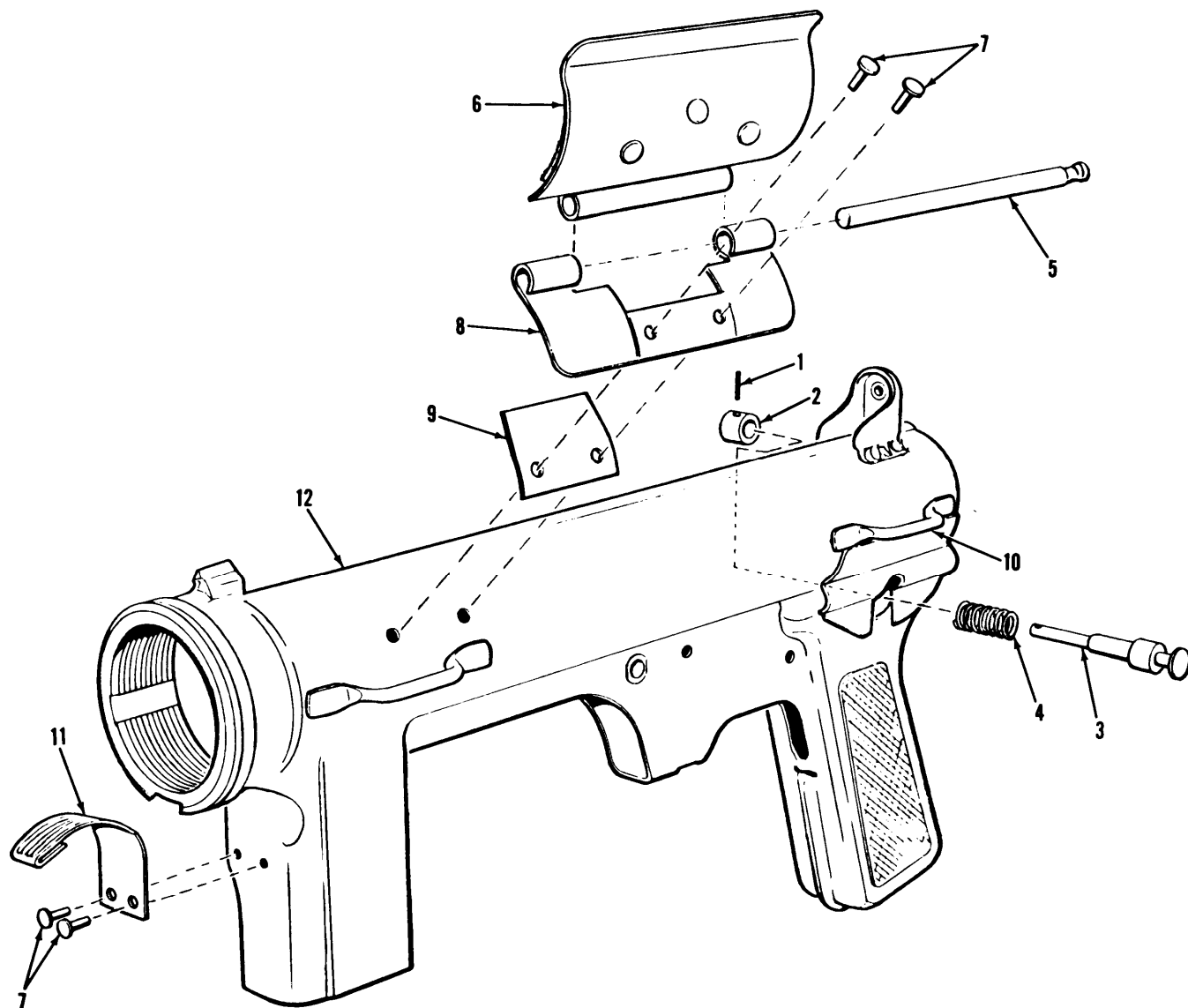


*Figure B-6. Trigger and sear group, M3 and M3A1-
exploded view.*



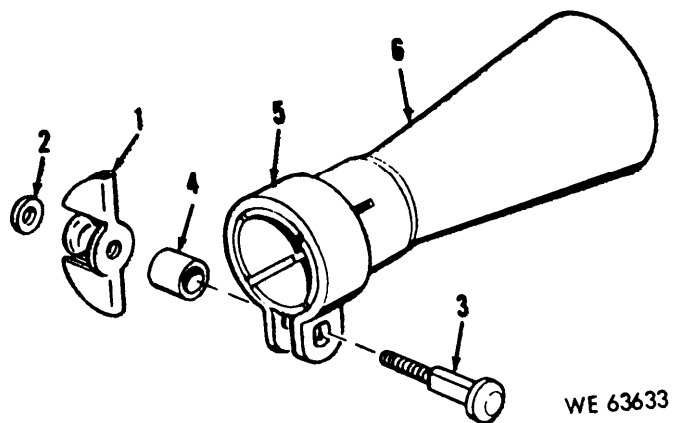
WE 63631

Figure B-7. Receiver assembly, M3A1 only-exploded view.



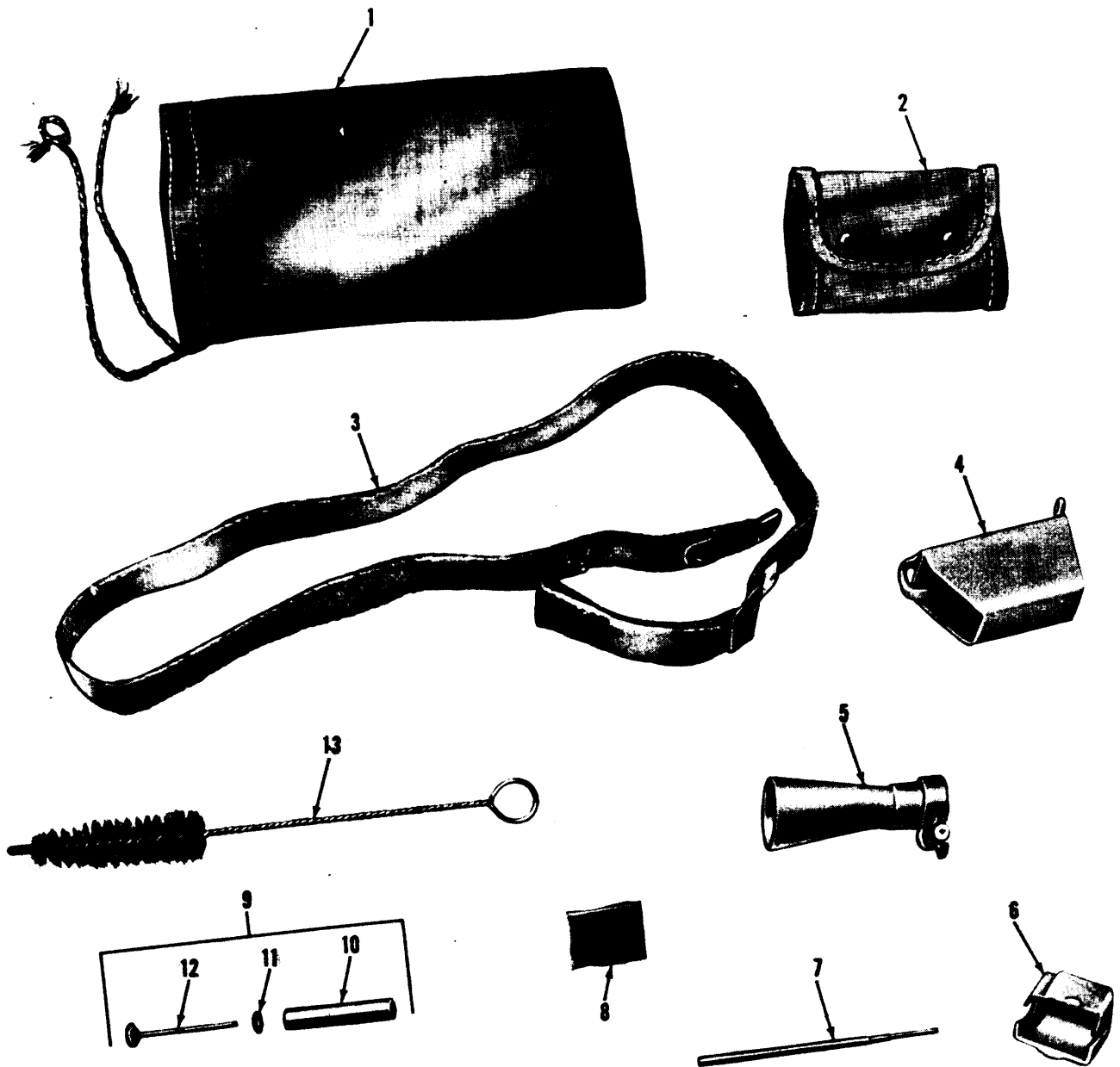
WE 63632

Figure B-8. Receiver assembly, M3 only—exploded view.



WE 63633

Figure B-9. Flash hider assembly-exploded view.



WE 63613

Figure B-10. Tools and equipment

**Section IV. INDEX - FEDERAL STOCK NUMBER AND REFERENCE
NUMBER CROSS-REFERENCE TO FIGURE AND ITEM NUMBER**

Stock Number	Figure No.	Item No.	Stock Number	Item No.	Figure No.
1005-200-5864	B-1	13	1005-716-0999	B-3	10
	B-2	13	1005-716-1812	B-1	2
	B-7	4		B-2	2
1005-209-9755	B-8	4	1005-716-1910	B-7	8
			1005-716-1911	B-7	12
1005-288-3565	B-10	8	1005-716-1913	B-7	11
1005-519-6456	B-10	11	1005-716-1922	B-7	6
1005-534-9925	B-5	3	1005-716-1923	B-1	7
1005-534-9927	B-7	3	1005-716-1926	B-3	8
	B-8	3	1005-716-1935	B-7	10
				B-8	11
1005-534-9931	B-3	1		B-6	2
1005-534-9932	B-8	9	1005-716-2774		
1005-534-9942	B-1	8	1005-722-8907	B-10	2
	B-2	8	1005-726-5628	B-10	5
1005-534-9947	B-7	2	1005-726-5632	B-9	3
	B-8	2	1005-726-5879	B-10	6
	B-5	6	1005-726-5970	B-9	1
1005-535-1191	B-3	2	1005-731-2910	B-7	15
1005-535-1195	B-6	4	1005-986-0261	B-1	3
1005-535-1196	B-5	10		B-2	3
1005-535-1210	B-10	3	4933-726-6175	B-10	7
1005-555-7152	B-10	1	5310-261-7161	B-7	14
1005-555-9738	B-10	9	5310-716-1905	B-7	13
1005-556-4364	B-1	1	5310-726-5634	B-9	2
1005-565-3427	B-2	1	5315-013-7155	B-5	1
	B-3	6	5315-534-9921	B-5	5
1005-565-3429	B-10	4	5315-534-9935	B-3	4
1005-565-3431	B-2	7	5315-534-9938	B-6	1
1005-565-3432	B-10	13	5315-534-9944	B-8	6
1005-610-8828	B-6	3	5315-534-9948	B-7	1
1005-630-1448	B-3	9		B-8	1
1005-630-1449	B-5	2	5315-535-1190	B-1	9
1005-630-1452	B-1	11		B-2	9
1005-630-1453	B-2	11	5315-716-1906	B-7	5
	B-1	6	5320-011-8047	B-4	1
1005-630-1456	B-2	6		B-5	11
	B-3	5		B-7	7
1005-630-1464	B-8	6		B-8	7
1005-630-1469	B-5	4	5320-682-1862	B-5	9
1005-630-1474	B-1	12	5340-535-1209	B-7	9
1005-716-0997	B-2	12		B-8	10

Reference No.	Mfg Code	Fig. No.	Item No.	Reference No.	Mfg Code	Fig. No.	Item No.
MS16535-114	96906	B-5	9	5349921	19204	B-5	5
101836	81580	B-7	14	5349925	19204	B-5	3
118047	19204	B-4	1	5349927	19205	B-7	3
		B-5	11			B-8	3
		B-7	7	5349931	19205	B-3	1
		B-8	7	5349932	19204	B-8	9
137155	00000	B-5	1	5349935	19204	B-3	4
5019316	19204	B-10	8	5349938	19204	B-6	1
5196456	19204	B-10	11	5349942	19204	B-1	8
5196480	19204	B-10	10			B-2	8
5-96481	19204	B-10	12	5349943	19204	B-6	5

**Section IV. INDEX - FEDERAL STOCK NUMBER AND REFERENCE
NUMBER CROSS-REFERENCE TO FIGURE AND ITEM NUMBER —**

Continued

5349944	19204	B-8	6	6301481	19204	B-5	8
5349947	19205	B-7	2	6301482	19204	B-5	12
		B-8	2	6573936	19204	B-1	14
5349948	19204	B-7	1	7160997	19204	B-1	12
		B-8	1			B-2	12
5351190	19204	B-1	9	7160998	19204	B-1	13
		B-2	9			B-2	13
5351191	19204	B-5	6	7160999	19204	B-3	10
5351194	19204	B-7	4	7161812	19204	B-1	2
		B-8	4			B-2	12
5351195	19204	B-3	2	7161905	19204	B-7	13
5351196	19204	B-6	4	7161906	19204	B-7	5
5351198	19204	B-5	7	7161910	19204	B-7	8
5351201	19204	B-8	8	7161911	19204	B-7	12
5351209	19204	B-7	9	7161913	19204	B-7	11
		B-8	10	7161918	19204	B-4	2
5351210	19205	B-5	10	7161921	19204	B-3	7
5557152	19204	B-10	3	7161922	19204	B-7	6
5559738	19204	B-10	1	7161923	19204	B-1	7
5564364	19204	B-10	9	7161926	19204	B-3	8
5653427	19204	B-1	1	7161927	19204	B-4	3
		B-2	1	7161930	19204	B-2	14
5653429	19204	B-3	6	7161931	19204	B-7	16
5653431	19204	B-10	4	7161935	19204	B-7	10
5653432	19204	B-2	7			B-8	11
5653433	19204	B-5	13	7162774	19204	B-6	2
6108828	19204	B-10	13	7228907	19204	B-10	2
6301448	19204	B-6	3	7265628	19204	B-10	6
6301449	19204	B-3	9	7625629	19204	B-9	6
6301450	19204	B-6	6	7265631	19204	B-9	5
6301452	19204	B-5	2	7265632	19204	B-9	3
6301453	19204	B-1	11	7265633	19204	B-9	4
		B-2	11	7265634	19204	B-9	2
6301456	19204	B-1	6	7265879	19204	B-10	6
		B-2	6	7265970	19204	B-9	1
6301464	19204	B-3	6	7266175	19204	B-10	7
6301469	19204	B-8	6	7310024	19205	B-8	12
6301470	19204	B-3	3	7312910	19204	B-7	15
6301472	19204	B-6	7	7791433	19204	B-1	8
6301474	19204	B-5	4			B-2	3

TM 9-1005-229-35

By Order of the Secretary of the Army:

Official:

KENNETH G. WICKHAM,
Major General, United States Army,
The Adjutant General.

W. C. WESTMORELAND,
General, United States Army,
Chief of Staff.

DISTRIBUTION :

To be distributed in accordance with DA Form 12-40, (qty rqr block no. 109) Direct and General Support maintenance requirements for Submachine Guns; Caliber .45, M3 and M3A1.

This fine document...

Was brought to you by me:



[Liberated Manuals -- free army and government manuals](#)

Why do I do it? I am tired of sleazy CD-ROM sellers, who take publicly available information, slap “watermarks” and other junk on it, and sell it. Those masters of search engine manipulation make sure that their sites that sell free information, come up first in search engines. They did not create it... They did not even scan it... Why should they get your money? Why are not letting you give those free manuals to your friends?

I am setting this document FREE. This document was made by the US Government and is NOT protected by Copyright. Feel free to share, republish, sell and so on.

I am not asking you for donations, fees or handouts. If you can, please provide a link to liberatedmanuals.com, so that free manuals come up first in search engines:

<A HREF=<http://www.liberatedmanuals.com/>>Free Military and Government Manuals

- Sincerely
Igor Chudov
<http://igor.chudov.com/>
- [Chicago Machinery Movers](#)