**CALIFORNIA
Proposition 65 Warning**

Diesel engine exhaust and some of its constituents are known to the State of California to cause cancer, birth defects, and other reproductive harm.

42824

To the Operator

This guide contains instructions on the safe operation and preventive maintenance of your Detroit Diesel MBE 4000 engine. Maintenance instructions cover routine engine services such as lube oil and filter changes in enough detail to permit self-servicing if desired.

The operator should become familiar with the contents of this guide before operating the engine or carrying out maintenance procedures.

Power-driven equipment is only as safe as the person operating the controls. You are urged, as the operator of this diesel engine, to keep fingers and clothing away from the revolving belts, drive shafts, etc. on engine installation.

Throughout this guide **CAUTIONS** regarding personal safety and **NOTICES** regarding engine performance or service life will appear. To avoid personal injury and ensure long engine service life, always heed these instructions.

Whenever possible, it will benefit you to rely on an authorized Detroit Diesel® service outlet for all your service needs from maintenance to major parts replacement. Authorized service outlets worldwide stock factory original parts and have the specialized equipment and

experienced, trained personnel to provide prompt preventive maintenance and skilled engine repairs.

The information and specifications in this publication are based on the information in effect at the time of approval for printing. Contact an authorized Detroit Diesel service outlet for information on the latest revision. The right is reserved to make changes at any time without obligation.

NOTICE:

Coolant must be inhibited with the recommended Supplemental Coolant Additives (SCA) listed in this guide. In addition, the engine can be equipped with a coolant filter/inhibitor system as an installed option or as an after-sale item. Failure to check and maintain SCA levels at required concentrations will result in severe damage corrosion to the engine cooling system and related components.

Trademark Information

Detroit Diesel®, DDEC®, and Diagnostic Link® are registered trademarks of Detroit Diesel Corporation. Nexiq™ is a trademark of Nexiq Technologies, Inc. All other trademarks are the property of their respective owners.

TABLE OF CONTENTS

| | |
|---|----|
| CAUTION SUMMARY | 1 |
| ENGINE OPERATION | 1 |
| PREVENTIVE MAINTENANCE | 2 |
| ELECTRICAL SYSTEM | 4 |
| COOLING SYSTEM | 6 |
| AIR INTAKE SYSTEM | 6 |
| FUEL SYSTEM | 7 |
| COMPRESSED AIR | 9 |
| LUBRICATING OIL AND FILTERS | 9 |
| IDENTIFICATION | 10 |
| PERSONNEL REQUIREMENTS | 11 |
| ENGINE CONVERSIONS AND MODIFICATIONS | 11 |
| GENERAL VIEW OF THE MBE 4000 ENGINE | 11 |
| ENGINE TYPE PLATE | 14 |
| DETAILS ON THE PLATE | 14 |
| ENGINE FEATURES | 15 |
| EXHAUST BRAKE/CONSTANT-THROTTLE VALVES | 16 |
| TURBO BRAKE, OPTIONAL | 17 |
| EXHAUST GAS RECIRCULATION | 17 |
| ELECTRONIC ENGINE CONTROL SYSTEM | 18 |
| DDEC-ECU — ENGINE-RESIDENT CONTROL UNIT | 19 |
| VEHICLE CONTROL UNIT | 20 |
| SENSOR LOCATIONS | 20 |
| OPERATION | 22 |
| BEFORE STARTING THE ENGINE | 22 |
| CHECKING THE BATTERIES | 22 |
| CHECKING THE OIL LEVEL | 23 |
| CHECKING THE COOLANT LEVEL (COLD CHECK) | 24 |
| ADDING FUEL | 24 |
| PRIMING THE FUEL SYSTEM | 24 |
| STARTING THE ENGINE | 25 |
| CHECKING THE COOLANT LEVEL (HOT CHECK) | 25 |

TABLE OF CONTENTS

| | |
|--|-----------|
| STARTING AN ENGINE THAT HAS NOT BEEN RUN FOR A LONG TIME | 26 |
| MONITORING ENGINE OPERATION | 27 |
| BATTERY CHARGE | 27 |
| OIL PRESSURE | 27 |
| EXCESSIVE IDLING | 28 |
| CHANGING THE IDLE SPEED | 28 |
| SHUTTING DOWN THE ENGINE | 28 |
| SHUTTING DOWN AFTER HIGH LOAD OPERATION | 28 |
| EMERGENCY RUNNING MODE | 29 |
| STOP ENGINE OVERRIDE OPTION | 29 |
| COLD WEATHER OPERATION | 30 |
| WINTER FRONTS | 30 |
| CLEANING AND STORAGE | 31 |
| CLEANING THE ENGINE | 31 |
| HIGH-PRESSURE CLEANING EQUIPMENT | 31 |
| CLEANING THE COOLING SYSTEM | 31 |
| DEGREASING | 32 |
| STORAGE | 33 |
| TROUBLESHOOTING | 34 |
| EMERGENCY STARTING | 34 |
| TROUBLESHOOTING THE ELECTRONIC ENGINE CONTROL SYSTEM | 34 |
| GENERAL TROUBLESHOOTING | 35 |
| SERVICE PRODUCTS | 48 |
| DIESEL FUELS | 48 |
| FLOW IMPROVERS | 48 |
| KEROSENE | 48 |
| ENGINE OILS | 49 |
| SYNTHETIC OILS | 49 |
| COOLANT | 50 |
| FULLY-FORMULATED ANTIFREEZE | 50 |
| WATER | 50 |
| COOLANT SPECIFICATIONS | 51 |
| COOLANT CONCENTRATION | 51 |

| | |
|---|-----------|
| SUPPLEMENTAL COOLANT ADDITIVES FOR FULLY FORMULATED COOLANT | 52 |
| DROPOUT | 52 |
| NON-APPROVED COOLANTS | 52 |
| RECYCLED ANTIFREEZE | 53 |
| CORROSION INHIBITORS | 53 |
| DISPOSAL | 54 |
| COLD WEATHER PRODUCTS | 54 |
| WINTER-GRADE DIESEL FUEL | 54 |
| LOW-VISCOSITY ENGINE OIL | 55 |
| WINTER COOLANT ANTIFREEZE PROTECTION | 55 |
| BATTERIES | 55 |
| TECHNICAL DATA | 56 |
| ENGINE DATA | 57 |
| TESTING AND ADJUSTING VALUES | 58 |
| MAINTENANCE | 60 |
| SCHEDULED INTERVALS | 60 |
| MAINTENANCE SCHEDULE TYPES | 60 |
| SEVERE SERVICE | 60 |
| SHORT-HAUL | 61 |
| LONG-HAUL | 61 |
| MAINTENANCE SCHEDULE AND INTERVAL OPERATIONS | 61 |
| MAINTENANCE INTERVALS | 61 |
| MAINTENANCE OPERATION SETS | 61 |
| SCHEDULE USE | 62 |
| MAINTENANCE TABLES | 63 |
| REQUIRED MAINTENANCE OPERATIONS | 69 |
| ENGINE INSPECTING | 69 |
| VALVE LASH CHECKING AND ADJUSTING | 69 |
| GAINING ACCESS TO THE VALVES | 69 |
| CHOOSING A METHOD | 70 |
| METHOD ONE | 71 |
| METHOD TWO | 72 |
| ADJUSTING VALVE LASH | 73 |
| RESTORING THE VEHICLE TO OPERATING CONDITION .. | 73 |

TABLE OF CONTENTS

| | |
|--|----|
| FUEL/WATER SEPARATOR PREFILTER ELEMENT CLEANING | 74 |
| FUEL PRO® 382 FUEL/WATER SEPARATOR ELEMENT REPLACEMENT | 75 |
| MAIN FUEL FILTER ELEMENT CHANGING | 76 |
| ENGINE OIL AND FILTER CHANGING | 77 |
| OPTIONAL OIL CENTRIFUGE | 80 |
| COOLANT CONCENTRATION AND INHIBITOR LEVEL CHECKING | 81 |
| COOLANT INHIBITOR TEST INTERVALS | 82 |
| INHIBITOR LEVEL CHECKING | 84 |
| COOLANT FLUSHING AND CHANGING | 85 |
| COOLING SYSTEM INSPECTING | 86 |
| REAR ENGINE POWER TAKE-OFF (REPTO) | 87 |
| REPTO TORSIONAL DAMPER INSPECTION | 87 |
| REPTO TORSIONAL DAMPER CLEANING | 87 |
| CUSTOMER ASSISTANCE | 89 |
| WORKING WITH DDC SERVICE OUTLETS | 93 |
| STEP ONE | 93 |
| STEP TWO | 93 |
| STEP THREE | 94 |
| LIMITED WARRANTY ON NEW DETROIT DIESEL MBE 4000 ENGINES USED IN ON-HIGHWAY VEHICLE APPLICATIONS | 95 |
| TERMS OF COVERAGE | 95 |
| USES | 95 |
| DEFECTS | 95 |
| REPAIRS | 95 |
| WARRANTY PERIOD | 95 |
| LIKE REPLACEMENT ENGINE | 96 |
| SERVICE SUPPLIES | 96 |
| ENGINE REMOVAL AND REINSTALLATION | 96 |
| THIS WARRANTY DOES NOT COVER: | 97 |
| REPAIRS DUE TO ACCIDENTS, MISUSE, STORAGE DAMAGE, NEGLIGENCE OR CERTAIN MODIFICATIONS | 97 |
| FUEL INJECTION SYSTEM AFTER 100,000 MILES/160, 000 KILOMETERS | 97 |
| MAINTENANCE | 97 |

| | |
|--|-----------|
| INCIDENTAL OR CONSEQUENTIAL DAMAGES | 97 |
| OTHER LIMITATIONS | 97 |
| LIMITED WARRANTY ON NEW DETROIT DIESEL MBE 4000 ENGINES USED IN FIRE TRUCK OR CRASH VEHICLE | |
| APPLICATIONS | 99 |
| TERMS OF COVERAGE | 99 |
| USES | 99 |
| DEFECTS | 99 |
| REPAIRS | 99 |
| WARRANTY PERIOD | 99 |
| LIKE REPLACEMENT ENGINE | 100 |
| SERVICE SUPPLIES | 100 |
| ENGINE REMOVAL AND REINSTALLATION | 100 |
| THIS WARRANTY DOES NOT COVER: | 100 |
| REPAIRS DUE TO ACCIDENTS, MISUSE, STORAGE DAMAGE, NEGLIGENCE OR CERTAIN MODIFICATIONS | 100 |
| FUEL INJECTION SYSTEM AFTER 100,000 MILES/160, 000 KILOMETERS | 100 |
| MAINTENANCE | 101 |
| INCIDENTAL OR CONSEQUENTIAL DAMAGES | 101 |
| OTHER LIMITATIONS | 101 |

TABLE OF CONTENTS

CAUTION SUMMARY

The following cautions must be observed by the operator of the vehicle or equipment in which this engine is installed and/or by those performing basic engine preventive maintenance. Failure to read and heed these cautions and exercise reasonable care for personal safety and the safety of others when operating the vehicle/equipment or performing basic engine preventive maintenance may result in personal injury and engine and/or vehicle/equipment damage.

Engine Operation

Observe the following cautions when operating the engine.



WARNING:

FIRE

To avoid injury from fire, keep all potential ignition sources away from diesel fuel, including open flames, sparks, and electrical resistance heating elements. Do not smoke when refueling.



WARNING:

PERSONAL INJURY

Diesel engine exhaust and some of its constituents are known to the State of California to cause cancer, birth defects, and other reproductive harm.

- Always start and operate an engine in a well ventilated area.**
- If operating an engine in an enclosed area, vent the exhaust to the outside.**
- Do not modify or tamper with the exhaust system or emission control system.**

Preventive Maintenance

Observe the following cautions when performing preventative maintenance.



WARNING:

HOT OIL

To avoid injury from hot oil, do not operate the engine with the rocker cover(s) removed.



WARNING:

PERSONAL INJURY

To avoid injury from slipping and falling, immediately clean up any spilled liquids.



CAUTION:

USED ENGINE OIL

To avoid injury to skin from contact with the contaminants in used engine oil, wear protective gloves and apron.



WARNING:

PERSONAL INJURY

To avoid injury when working near or on an operating engine equipped with an hydraulic clutch fan, remove loose items of clothing and jewelry. Tie back or contain long hair that could be caught in any moving part causing injury. The hydraulic fan may start without warning.



WARNING:

HOT COOLANT

To avoid scalding from the expulsion of hot coolant, never remove the cooling system pressure cap while the engine is at operating temperature. Wear adequate protective clothing (face shield, rubber gloves, apron, and boots). Remove the cap slowly to relieve pressure.



WARNING:
PERSONAL INJURY

To avoid injury from the projection of tools or other objects that may fall on or behind the vibration damper of an engine, always check and remove these items before starting the engine.



WARNING:
FIRE

To avoid injury from combustion of heated lubricating-oil vapors, stop the engine immediately if an oil leak is detected.



WARNING:
PERSONAL INJURY

To avoid injury from contact with rotating parts when an engine is operating with the air inlet piping removed, install an air inlet screen shield over the turbocharger air inlet. The shield prevents contact with rotating parts.



WARNING:
FIRE

To avoid injury from fire, do not smoke or allow open flames when working on an operating engine.



WARNING:
FIRE

To avoid injury from fire from a buildup of volatile vapors, keep the engine area well ventilated during operation.



WARNING:
PERSONAL INJURY

To avoid injury when using caustic cleaning agents, follow the chemical manufacturers usage, disposal, and safety instructions.

Electrical System

Observe the following cautions when jump starting an engine, charging a battery, or working with the vehicle electrical system.



WARNING: PERSONAL INJURY

To avoid injury from accidental engine startup while servicing the engine, disconnect/disable the starting system.



CAUTION: Electrical Shock

To avoid injury from electrical shock, use care when connecting battery cables. The magnetic switch studs are at battery voltage.



WARNING: Battery Explosion and Acid Burn

To avoid injury from battery explosion or contact with battery acid, work in a well ventilated area, wear protective clothing, and avoid sparks or flames near the battery. If you come in contact with battery acid:

- Flush your skin with water.
- Apply baking soda or lime to help neutralize the acid.
- Flush your eyes with water.
- Get medical attention immediately.



WARNING: ELECTRICAL SHOCK

To avoid injury from electrical shock, do not touch battery terminals, alternator terminals, or wiring cables while the engine is operating.



WARNING:

Electrical Shock Hazard

High voltage can remain inside the Electrostatic Oil Separator after removal. Wait 30 minutes after turning off the ignition before removing the separator. Never touch parts through ventilation openings or impeller opening with finger or conductive items (e.g. screwdriver or wire). High voltage can remain inside the Electrostatic Oil Separator for up to 12 hours after the ignition is turned off.

Cooling System

Observe the following cautions when servicing the cooling system.



WARNING: HOT COOLANT

To avoid scalding from the expulsion of hot coolant, never remove the cooling system pressure cap while the engine is at operating temperature. Wear adequate protective clothing (face shield, rubber gloves, apron, and boots). Remove the cap slowly to relieve pressure.



WARNING: PERSONAL INJURY

To avoid injury from slipping and falling, immediately clean up any spilled liquids.

Air Intake System

Observe the following cautions when working on the air intake system.



WARNING: PERSONAL INJURY

To avoid injury from hot surfaces, wear protective gloves, or allow engine to cool before removing any component.



WARNING: PERSONAL INJURY

To avoid injury from contact with rotating parts when an engine is operating with the air inlet piping removed, install an air inlet screen shield over the turbocharger air inlet. The shield prevents contact with rotating parts.

Fuel System

Observe the following cautions when fueling the vehicle or working with the fuel system.



CAUTION:

PERSONAL INJURY

To avoid injury from fuel spills, do not overfill the fuel tank.



WARNING:

FIRE

To avoid injury from fire, keep all potential ignition sources away from diesel fuel, including open flames, sparks, and electrical resistance heating elements. Do not smoke when refueling.



WARNING:

FIRE

To avoid injury from fire, contain and eliminate leaks of flammable fluids as they occur. Failure to eliminate leaks could result in fire.



WARNING:

PERSONAL INJURY

To prevent the escape of high pressure fuel that can penetrate skin, ensure the engine has been shut down for a minimum of 10 minutes before servicing any component within the high pressure circuit. Residual high fuel pressure may be present within the circuit.



WARNING:

FIRE

To avoid injury from fire caused by heated diesel-fuel vapors:

- **Keep those people who are not directly involved in servicing away from the engine.**
- **Stop the engine immediately if a fuel leak is detected.**
- **Do not smoke or allow open flames when working on an operating engine.**
- **Wear adequate protective clothing (face shield, insulated gloves and apron, etc.).**
- **To prevent a buildup of potentially volatile vapors, keep the engine area well ventilated during operation.**

Compressed Air

Observe the following cautions when using compressed air.

| |
|---|
|  WARNING: EYE INJURY |
| To avoid injury from flying debris when using compressed air, wear adequate eye protection (face shield or safety goggles) and do not exceed 276 kPa (40 psi) air pressure. |

Lubricating Oil and Filters

Observe the following cautions when replacing the engine lubricating oil and filters.

| |
|---|
|  WARNING: PERSONAL INJURY |
| To avoid injury from slipping and falling, immediately clean up any spilled liquids. |

| |
|---|
|  WARNING: FIRE |
| To avoid injury from combustion of heated lubricating-oil vapors, stop the engine immediately if an oil leak is detected. |

| |
|--|
|  WARNING: FIRE |
| To avoid injury from fire, do not smoke or allow open flames when working on an operating engine. |

| |
|---|
|  WARNING: FIRE |
| To avoid injury from fire from a buildup of volatile vapors, keep the engine area well ventilated during operation. |

IDENTIFICATION

The MBE 4000 engine is built in accordance with sound technological principles and based on state-of-the-art technology. It complies with all United States Environmental Protection

Agency (USEPA) and California Air Resources Board (CARB) emission standards. An emission label is attached to the cylinder head cover, as required by law. See Figure 1.

Important Engine Information

DaimlerChrysler do Brasil Ltda., do Campo, Sao Paulo, Brasil

| | |
|--|---|
| <p>MercedesBenz Engine, Model Engine Family Exhaust Emission Control System Date of engine manufacture Advertised Output (SAE gr.) Fuel rate at adv. output Valve lash cold (ins.) Basic injection timing Idle speed</p> | <p>OM 460 LA 12.8L 4MBXH 12.8DJA TC, EMC, CAC 2004 335 KW (450 HP/1900 rpm) 259 - 274 mm ³/ stroke 0.016 int. 0.024 exh. 12.0°±1° BTDC 550 ± 100 rpm</p> |
|--|---|

This engine conforms to U.S. EPA, California and Canada regulations, applicable to 2004 Model Year. This engine has a primary intended service application as a heavy HD diesel engine. This engine is not certified for use in an urban bus as defined at 40 CFR 86.093.2. Sales of this engine for use in an urban bus is a violation of Federal Law under the Clean Air Act. This engine is certified to be operated on diesel fuel.

44089

Figure 1 Emission Label, MBE 4000

Despite this, the engine may constitute a risk of damage to property or injury to persons under the following conditions:

- It is not used for its intended purpose.
- It is modified or converted in an incorrect manner.
- The safety instructions included in this manual are disregarded.

General View of the MBE 4000 Engine

For a general view of the MBE 4000 engine, showing major components, see Figure 2 for the left-hand side, and Figure 3 for the right-hand side.

Personnel Requirements

Work on the engine should be carried out only by skilled technicians who have been instructed in the specific skills necessary for the type of work being performed.

Engine Conversions and Modifications

The function and safety of the engine could be affected if unauthorized modifications are made to it. Detroit Diesel will not accept responsibility for any resulting damage.

Tampering with the fuel injection system and engine electronics could also affect the engine's power output or exhaust emission levels. Compliance with the manufacturer's settings and with statutory environmental protection regulations cannot then be guaranteed.

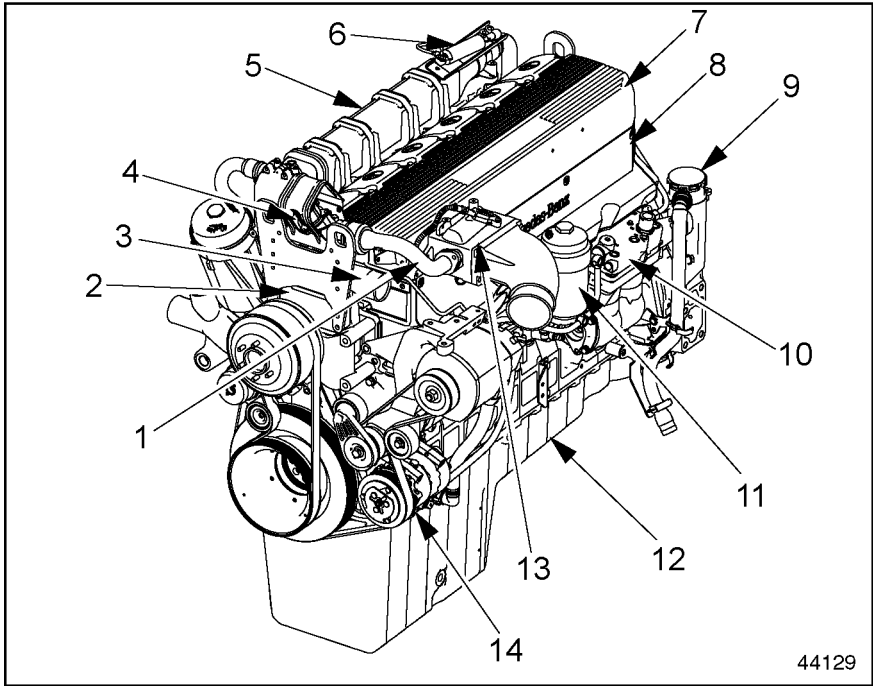

- | | |
|-------------------------------|---------------------------------|
| 1. EGR Outlet Pipe | 8. Engine Trim Cover |
| 2. Coolant Pump | 9. Crankcase Breather |
| 3. Thermostat Housing | 10. Air Compressor |
| 4. Modulated EGR Valve | 11. Fuel Filter Housing |
| 5. EGR Cooler | 12. Oil Pan |
| 6. EGR Shutoff Valve (hidden) | 13. EGR Mixer |
| 7. Air Intake Manifold | 14. Air Conditioning Compressor |

Figure 2 Major Engine Components, Left Side

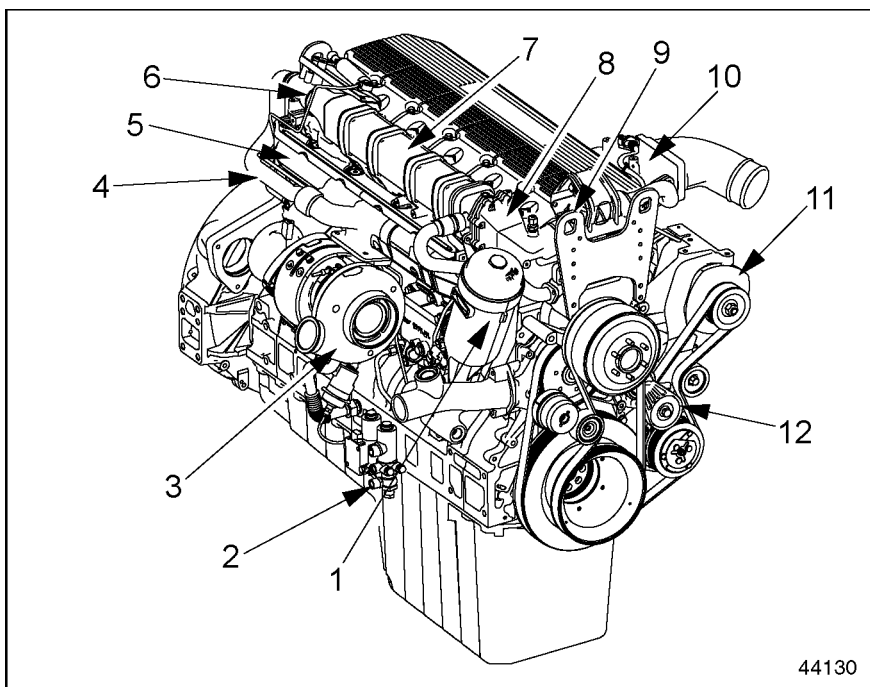

44130

- | | |
|--------------------------------------|-----------------------|
| 1. Oil Filter | 7. EGR Cooler |
| 2. Air Solenoid Valve (Engine Brake) | 8. Reed Valve Housing |
| 3. Turbocharger | 9. EGR Control Valve |
| 4. EGR Hot Pipe | 10. EGR Mixer |
| 5. Exhaust Manifold | 11. Alternator |
| 6. EGR Shutoff Valve | 12. Belt Tensioner |

Figure 3 Major Engine Components, Right Side

Engine Type Plate

The engine type plate is used to identify the engine. It is located on the oil filter housing. See Figure 4.

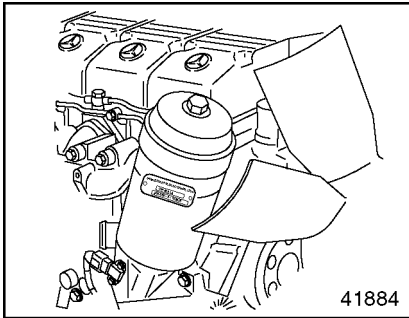

Figure 4 Location of Engine Type Plate

Details on the Plate

The engine type reference, OM 460 LA, is the production code. The first three numbers of the engine serial number are the model number. See Figure 5.

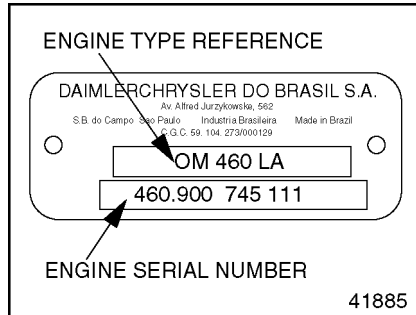

Figure 5 Engine Type Plate

The last six numbers are the serial numbers (745111 in see Figure 5).

NOTE:

In addition to the fourteen digit number etched on the crankcase, there is a ten digit number used for warranty and service that is found on the DDEC-ECU label. The ten digit number is derived from the fourteen digit number (see Figure 6).

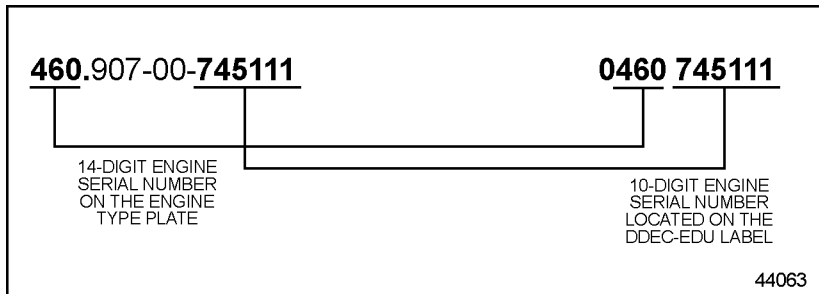

Figure 6 Engine Serial Number

Engine Features

All MBE 4000 engines are water-cooled, four-stroke, direct-injection inline diesel engines. Each cylinder has a separate fuel injection pump (unit pump) with a short injection line to the injection nozzle, which is located in the center of the combustion chamber. The unit pumps are attached to the crankcase and are driven from the camshaft. Each cylinder has two intake valves and two exhaust valves.

Charge-air cooling and an exhaust gas turbocharger are standard equipment.

The engine has a fully electronic control system consisting of a DDEC-ECU (Engine Control Unit) and a DDEC-VCU (Vehicle Control Unit) connected by a proprietary datalink. This system regulates the injection quantity and timing using solenoid valves, allowing extremely low-emission operation.

Standard engine braking is controlled by a pneumatically-operated exhaust brake on the turbocharger and by a hydraulically-operated constant-throttle system. For greater braking power, an optional turbo brake is available.

The cylinder block has integrated oil and water channels. The upper section of the cylinder bore has a carbon scraper ring seated in a groove on the top part of the cylinder. The six

individual cylinder heads are made of cast iron. The cylinder head gasket is an adjustment-free seal with rubber sealing elements.

The pistons are made of aluminum alloy with ring carriers and a shallow combustion chamber recess. The pistons are cooled by oil spray nozzles.

The crankshaft is precision-forged with seven main bearings and eight custom-forged counter weights, and a vibration damper at the front end.

The camshaft is made of induction-hardened steel and has seven cam bearings. Each cylinder has cams for intake and exhaust valves and a unit pump.

The valves are controlled by roller tappets, pushrods, and rocker arms. The intake and exhaust valves are opened and closed by a free-floating valve bridge.

There is a force-feed lubricating oil circuit supplied by a gear-type oil pump. This pump is positioned at the rear of the oil pan and driven by gears from the crankshaft. The oil heat exchanger is integrated with the oil filter housing on the right-hand side.

The gear-type fuel pump is located near the front of the crankcase on the left hand side. The pump is driven from the forward end of the camshaft.

IDENTIFICATION

The air compressor, with a power-steering pump attached, is driven by a gear on the camshaft.

The engine is cooled by a closed system using recirculated coolant; temperature is regulated automatically by a thermostat.

There are two main drive belts, each with its own automatic belt tensioner.

The alternator and coolant pump (and any other accessories) and the refrigerant compressor are driven by a main drive belt. The fan is driven by its own drive belt.

Electrical equipment includes a starter and an alternator.

Exhaust Brake/Constant-Throttle Valves

To increase braking performance, the engine is equipped with an exhaust brake on the turbocharger in conjunction with constant-throttle valves on the cylinder head. See Figure 7.

NOTE:

On EGR engines, the constant-throttle valves are activated by engine oil pressure.

The exhaust back pressure is used by the exhaust brake to increase braking performance.

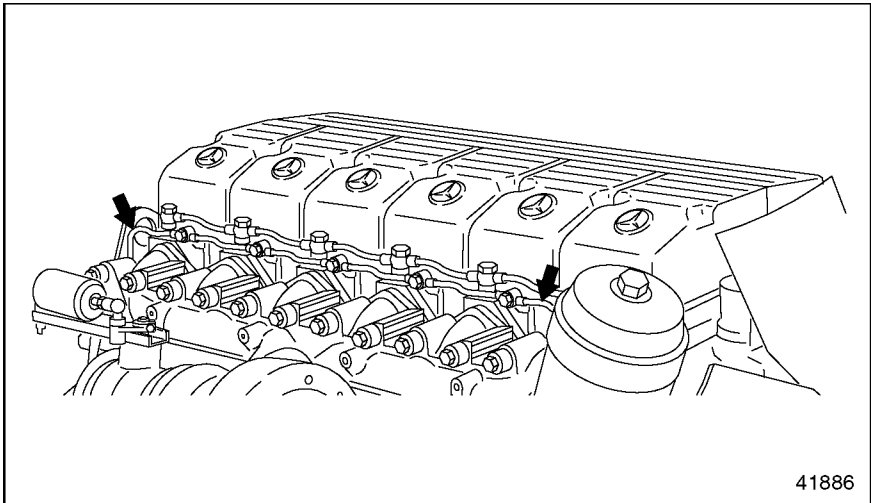

Figure 7 Constant-Throttle Activation (shown with EGR system removed)

The constant-throttle valves use the air that escapes through them on the compression stroke to provide braking force. The constant throttles are small valves which are built into the cylinder heads. When open, a link is created between the combustion chamber and the exhaust port.

The engine brake is activated by the DDEC-VCU. In engine braking mode, an engine rpm range of up to 2,500 rpm can be used by the operator. 2,500 rpm, however, may never be exceeded. The engine is turned off automatically when the engine rpm is:

- Below 900 rpm for Allison Automatic Transmissions
- Below 1100 rpm for all other transmissions

Also, the engine brake is automatically turned off when the accelerator pedal is pressed.

NOTE:

When in emergency running mode (constant rpm), the engine brake can be activated only when the engine is in overrun. When constant rpm has been attained, the engine brake is automatically turned off.

Turbo Brake, Optional

For high braking output, the MBE 4000 engine can be equipped with an optional turbo brake. The turbo brake increases the air mass flow through the

engine to provide very high braking horsepower.

The turbo brake can be operated either manually or automatically, through the cruise control function.

Because the charge air pressure is maintained at a high level during braking, full throttle response is available immediately, if the operator desires it, without any turbo lag.

The turbo brake is maintenance-free, highly reliable, and adds virtually no weight to the engine.

Exhaust Gas Recirculation

The purpose of the Exhaust Gas Recirculation (EGR) System is to reduce engine exhaust gas emissions in accordance with EPA regulations.

The MBE 4000 engines for on-highway EPA 2004 regulation applications use a cooled EGR system consisting of an EGR cooler, EGR control valves, reed valves, and an EGR mixer.

In the cooled EGR system, part of the exhaust gasses from the front three cylinders are routed from the exhaust manifold through the EGR cooler, past control and reed valves, and are mixed with the intake manifold charge air.

The addition of cooled exhaust gasses back into the combustion airflow reduces the peak in cylinder combustion temperature. Less oxides of nitrogen (NOx) are produced at lower combustion temperatures.

The recycled exhaust gases are cooled before engine consumption in a tube and shell engine water cooler.

Electronic Engine Control System

The engine is equipped with a fully electronic control system. See Figure 8.

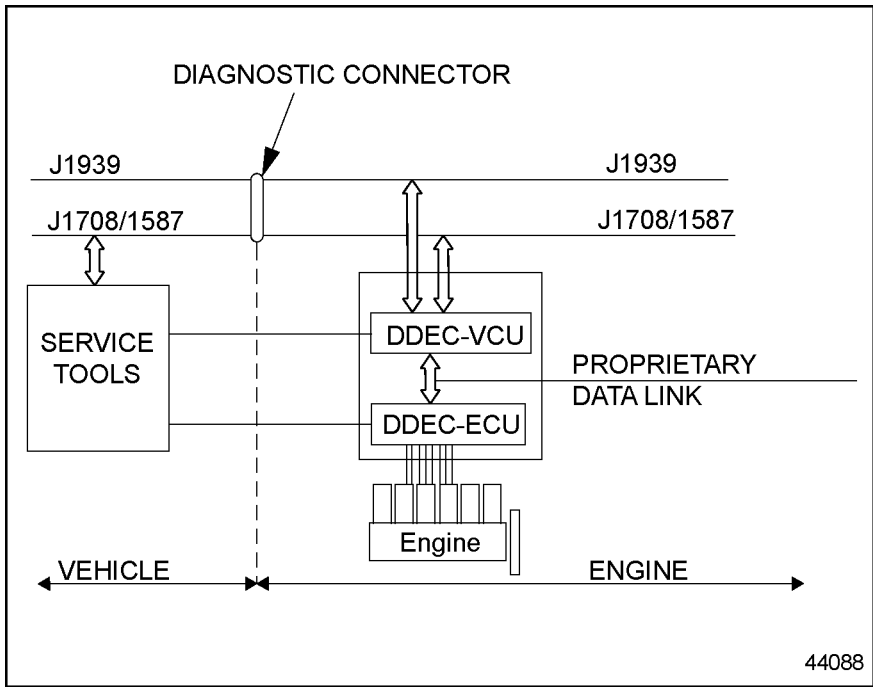

Figure 8 Electronic Engine Control System

This system is composed of the DDEC-ECU (Engine Control Unit)

and the DDEC-VCU (Vehicle Control Unit).

The two control units are connected by a proprietary datalink through which all necessary data and information can be exchanged. The DDEC-VCU then broadcasts all information on the J1587 and J1939 datalinks, where it can be read by minidiag2, the Nexiq™ Diagnostic Data Reader (DDR) or Detroit Diesel Diagnostic Link® (DDDL) PC software.

The DDEC-ECU monitors both the engine and the datalink. When a malfunction or other problem is detected, the system selects an appropriate response; for example, the emergency running mode may be activated. For more information on the emergency running mode, refer to the “Emergency Running Mode” section under “Operations.”

DDEC-ECU — Engine-Resident Control Unit

The DDEC-ECU (see see Figure 9) is located on the left-hand side of the engine.

The DDEC-ECU processes the data received from the DDEC-VCU, for example the position of the accelerator pedal, engine brake, etc.

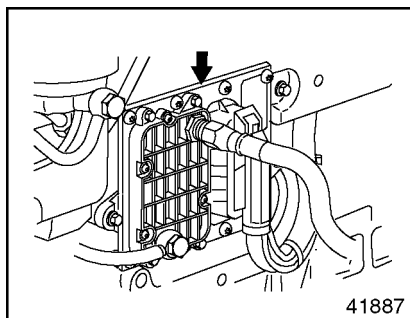

Figure 9 DDEC-ECU

These data are evaluated together with the data from the sensors on the engine, such as coolant and fuel temperature and oil and charge pressure.

The data is then compared to the characteristic maps or lines stored in the DDEC-ECU.

From these data, quantity and timing of injection are calculated and the unit pumps are actuated accordingly through the solenoid valves.

NOTE:

To obtain a replacement DDEC-ECU, all the data given on the DDEC-ECU label are required.

The DDEC-ECU data label has the 10 digit engine serial number (see Figure 6), the engine horse power and torque.

Vehicle Control Unit

The DDEC-VCU, see Figure 10, communicates with the other electronic control units installed on the vehicle over the J1587 and J1939 data link.

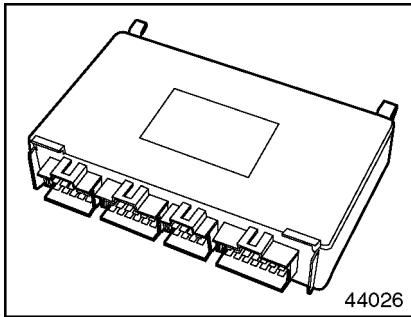

Figure 10 DDEC-VCU

Sets of data for specific applications are stored in the DDEC-VCU including idle speed, maximum running speed, and speed limitation.

The DDEC-VCU receives data from the following sources:

- The operator (accelerator pedal position, engine brake switch)
- Other electronic control units (the antilock brake system)
- The DDEC-ECU (oil pressure and coolant temperature)

From these data, instructions are computed for controlling the engine

and transmitted to the DDEC-ECU via the proprietary data link.

The DDEC-VCU controls various systems, for example, communications with the datalink and the engine brake.

If the engine control system detects a fault, the appropriate fault code is broadcast on the datalink and can be read using minidiag2, the Nexiq DDR or DDDL PC software. Fault code information may also be available on the vehicle or equipment instrument panel.

Sensor Locations

Use caution when handling the sensors.



CAUTION:

CHEMICAL BURNS

To avoid injury from chemical burns, wear a face shield and neoprene or PVC gloves when handling sensor hoses.

The Engine Oil Pressure/Temperature Sensor is located at the base of the oil filter.

See Figure 11 for sensor locations on the MBE 4000 engine.

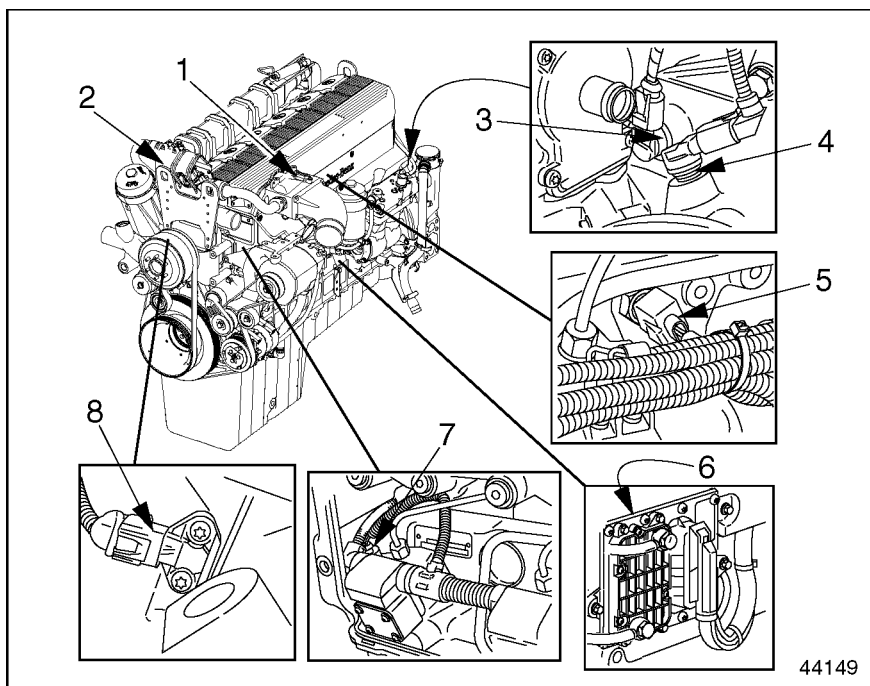

44149

- | | |
|---|--|
| 1. Intake Air Pressure/Temperature Sensor | 5. Engine Coolant Temperature Sensor |
| 2. EGR Temperature Sensor | 6. Barometric Pressure Sensor (Integrated into DDEC-ECU) |
| 3. Camshaft Position Sensor | 7. Supply Fuel Temperature Sensor |
| 4. Crankshaft Position Sensor | 8. Engine Oil Pressure/Temperature Sensor |

Figure 11 Sensor Location

OPERATION

Important: Before starting the engine, carefully read all operating instructions in this manual and do all the recommended pretrip inspections and daily maintenance. Check the engine oil and fuel levels, and drain contaminants from the fuel/water separator (optional).

Before Starting the Engine

NOTE:

If you drain the fuel/water separator completely, you may have to prime the fuel system.

Be sure you are familiar with all of the instruments, gauges and controls which are needed to operate the engine.

Note especially the location and function of the following:

- Oil pressure gauge
- Low oil pressure warning light
- Coolant temperature gauge
- High coolant temperature warning light
- Water in fuel warning light
- Tachometer
- Air restriction indicator

Watch for any signs of engine problems when starting or driving. If

the engine overheats, uses excessive fuel or lubricating oil, vibrates, misfires, makes unusual noises, or shows an unusual loss of power, turn the engine off as soon as possible and determine the cause of the problem. Engine damage may be avoided by a quick response to early indications of problems.

When starting the engine in cold weather, refer to the “ Service Products” section.

Checking the Batteries

Use only batteries that have been correctly filled and serviced. To provide corrosion protection, apply dielectric grease, part number 48-02349-000, liberally to the terminal pads. Approved suppliers are listed in Table 1.

| Manufacturer | Lubricant or Part Number |
|---------------|--------------------------|
| Shell Oil Co. | No. 71032; No. 71306 |
| Texaco, Inc. | No. 955 |
| Quaker State | No. NYK-77 |

Table 1 Approved Electrical Lubricants

**WARNING:****Battery Explosion and Acid Burn**

To avoid injury from battery explosion or contact with battery acid, work in a well ventilated area, wear protective clothing, and avoid sparks or flames near the battery. If you come in contact with battery acid:

- Flush your skin with water.
- Apply baking soda or lime to help neutralize the acid.
- Flush your eyes with water.
- Get medical attention immediately.

Checking the Oil Level

Check the oil level as follows:

1. Check the oil level using the oil dipstick (see Figure 12).

**WARNING:****PERSONAL INJURY**

To avoid injury from slipping and falling, immediately clean up any spilled liquids.

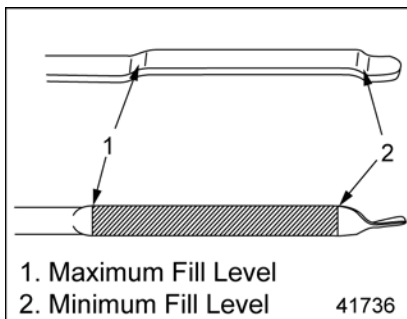
**Figure 12 Oil Dipstick**

2. If necessary, top off by filling engine oil through the oil fill cap (see Figure 13) to the maximum fill level on the oil dipstick.

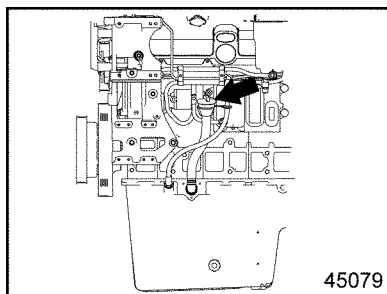
**Figure 13 Oil Fill Cap**

For detailed procedures, refer to the “Maintenance” section.

Checking the Coolant Level (Cold Check)

Check coolant level as follows:

1. Ensure that all coolant plugs in the bottom of the radiator and on the radiator outlet pipe are secure and tight.
2. Check the coolant level. The cooling system is correctly filled when the coolant is between the maximum and minimum marks on the surge tank.

For more information, refer to the "Maintenance" section.

Adding Fuel

When adding fuel, pay attention to the following:

- Add winter or summer grade fuel according to the season of the year.
- Work in the cleanest conditions possible.
- Prevent water from entering the fuel tank.

For further information, refer to the "Service Products" section.

Priming the Fuel System

Prime the fuel system as follows:

| NOTICE: |
|--|
| Correct torque on the high pressure lines is critical. Incorrect torques could result in leaks or lack of power due to restricted fuel flow. |
| <ol style="list-style-type: none">1. Make sure that all high-pressure and low-pressure lines are securely tightened. For tightening specifications, refer to the "Technical Data" section.2. If equipped with a hand pump on the fuel/water separator, work the hand pump 50 times. |

NOTE:

There should be a strong resistance in the hand pump, caused by the pressure buildup within the fuel system.

3. Crank the engine for 30 seconds at a time, but no longer. Wait at least two minutes. The engine should start within four 30-second attempts.

Starting the Engine

Before operating the engine, do the work described under "Before Starting the Engine." Start the engine as follows:

NOTICE:

Never attempt to start any Mercedes-Benz electronic engine using ether or any other starting fluid. Serious engine damage could result.



WARNING: PERSONAL INJURY

To avoid injury when working near or on an operating engine, remove loose items of clothing and jewelry. Tie back or contain long hair that could be caught in any moving part causing injury.

1. Turn on the ignition switch.
2. With the accelerator pedal in the idle position, start the engine.
3. Check the engine for leaks.
 - [a] Check all hoses, hose clamps, and pipe unions on the engine for tightness. Shut down the engine and tighten them if necessary.
 - [b] Check the oil feed and return lines at the turbocharger for tightness. Shut down the engine and tighten them if necessary.
4. Shut down the engine.
5. Approximately five minutes after shutdown, check the engine oil level. If necessary, add oil up to the maximum fill level on the oil dipstick.
6. Check all the mounting fasteners on the engine for tightness.

Checking the Coolant Level (Hot Check)

Check the coolant levels as follows:

1. Allow the engine to run for approximately five minutes at a moderate speed.



WARNING:

HOT COOLANT

To avoid scalding from the expulsion of hot coolant, never remove the cooling system pressure cap while the engine is at operating temperature. Wear adequate protective clothing (face shield, rubber gloves, apron, and boots). Remove the cap slowly to relieve pressure.

2. Then, with the coolant temperature above 50°C (122°F), recheck the coolant level.
3. Add more coolant if necessary. Open the heater valves before adding coolant.
4. Do not close the heater valves until the engine has been run briefly and the coolant level again checked and corrected as necessary.

Starting an Engine That Has Not Been Run for a Long Time

Before starting an engine which has not been run for a long time, certain special work must be carried out. Refer to the “Cleaning and Storage” section.

Important: At outside temperatures below -20°C (-4°F), a coolant preheater is recommended.

1. Chock the tires, place the transmission in neutral, and set the parking brake.
2. Turn on the ignition switch and start the engine
3. If the engine doesn't start after 20 seconds, stop. Try again after waiting about one minute.

NOTICE:

Do not rev the engine if the oil pressure gauge indicates no oil pressure. To avoid engine damage, shut down the engine within approximately ten seconds. Check to determine the cause of the problem.

4. Monitor the oil pressure gauge immediately after starting the engine.

NOTE:

Do not place the engine under full load until it reaches operating temperature.

Monitoring Engine Operation

While the engine is operating, monitor the battery charge indicator light, the oil pressure and avoid excessive idling.

Battery Charge

The battery charge indicator light (see Figure 14) must go out once the engine starts.

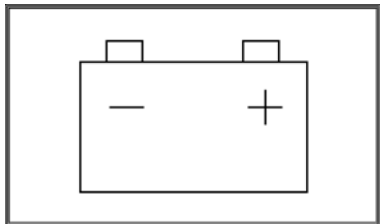

41737

Figure 14 Battery Charge Indicator Light

If the indicator light comes on while the engine is running, do the following:

1. Shut down the engine.
2. Check the poly-V belt for tightness.



WARNING:

FIRE

To avoid injury from fire, keep all potential ignition sources away from diesel fuel, including open flames, sparks, and electrical resistance heating elements. Do not smoke when refueling.

3. Do a load test on the batteries. Charge or replace the batteries as needed.
4. If necessary, visit the nearest authorized dealer to have the alternator voltage and output checked.

Oil Pressure

When the engine has reached its normal operating temperature, the engine oil pressure must not drop below the following values:

- 36 psi (250 kPa) at rated speed
- 7 psi (50 kPa) at idling speed

If oil pressure drops below these values, stop the engine and determine the cause.

Excessive Idling

Never allow the engine to idle for more than 30 minutes. Excessive idling can cause oil to leak from the turbocharger.

Changing the Idle Speed

The rpm range of the MBE 4000 engine is 600 to 850 rpm if the parameters in the DDEC-VCU are set to the default range.

Change the idle speed as follows:

1. Turn the cruise control switch to the OFF position.
2. To increase the idle speed, push the "Resume" switch until the idle is fast enough.
3. To decrease the idle speed, push the "Decel" switch until the idle is slow enough.

Shutting Down the Engine

If the engine has been running at full output or the coolant temperature has been high, allow the engine to idle for one to two minutes without load. Then turn off the ignition key switch.

If any the following occur, shut down the engine immediately.

- The oil pressure swings back and forth or falls sharply.

- Engine power and rpm fall, even though the accelerator pedal remains steady.
- The exhaust pipe gives off heavy smoke.
- The coolant and/or oil temperature climb abnormally.
- Abnormal sounds suddenly occur in the engine or turbocharger.

Shutting Down After High Load Operation

After high load operation, do the following:

| NOTICE: |
|--|
| After high load operation, allow the engine to idle for one to two minutes without load. Shutting down the engine without idling may cause damage to the turbocharger. |

1. If the engine has been running at full output or the coolant temperature has been high, allow the engine to idle for one to two minutes without load.
2. Turn off the ignition switch and shut down the engine.

Emergency Running Mode

The engine is equipped with the electronic engine control system, which monitors the engine as it is running.

As soon as a fault is detected, it is evaluated and one of the following measures is initiated.

NOTICE:

To prevent possible serious engine damage, have any faults corrected without delay by an authorized dealer.

- In conjunction with any dashboard or instrument panel display, the code for the electronic control unit reporting the fault can be read immediately on the display.
- Complete fault codes are transmitted and can be read using minidiag2, the Nexiq DDR or DDDL PC software.
- If the fault is serious enough to impair normal operation, the electronic engine system switches over to emergency running mode. When in emergency running mode, the engine operates at a constant 1300 rpm. This allows you to move the vehicle to a service location.

For fault codes and their meanings, see the vehicle service manual.

Stop Engine Override Option

The Stop Engine Override Option is used for a momentary override. The DDEC-ECU will record the number of times the override is activated after a fault occurs.

Momentary Override – A Stop Engine Override (SEO) switch is used to override the shutdown sequence (see Figure). This override resets the 60 second (30 seconds for oil pressure) shutdown timer, restoring power to the level when the Red Stop Lamp (RSL) was illuminated. The switch must be recycled after five seconds to obtain a subsequent override.

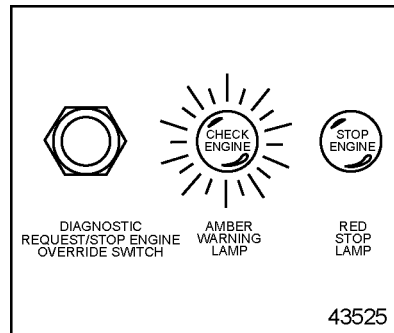

Figure 15 Typical SEO Switch and Warning Lamps

NOTE:

The operator has the responsibility to take action to avoid engine damage.

Cold Weather Operation

Special precautions must be taken during cold weather. To protect your engine, special cold weather handling is required for fuel, engine oil, coolant, and batteries.

Winter Fronts

A winter front may be used to improve cab heating while idling. At least 25% of the grill opening should remain open in sectioned stripes that run perpendicular to the charge air cooler tube flow direction. This assures even cooling across each tube and reduces header to tube stress and possible failure. Winter fronts should only be used when the ambient temperature remains below -12.2°C (10°F).

CLEANING AND STORAGE

Special precautions should be taken for a stored engine to protect the its interior and exterior.

Cleaning the Engine

Important: Observe all environmental protection regulations.

High-Pressure Cleaning Equipment

Information on suitable cleaning and protective products is available from any authorized dealer. Note the equipment manufacturer's operating instructions.

NOTICE:

To prevent damage to engine components, keep the water moving at all times while cleaning. Never direct water onto electrical components, plug connectors, seals or flexible hoses.

Comply with the minimum working distance between the high-pressure nozzle and the surface being cleaned:

- Approximately 28 inches (700 mm) for circular pattern jets
- Approximately 12 inches (300 mm) for 25-degree flat jets and dirt cutters

Cleaning the Cooling System

Important: Collect the used coolant, cleaning solutions, and washing liquids and dispose of them in an environmentally responsible manner.

Clean as follows:

NOTICE:

Clean at moderate pressures only; otherwise the fins of the radiator grille could be damaged.

1. First remove debris (dust, insects, etc.) from the fins of the radiator grille.



WARNING:

EYE INJURY

To avoid injury from flying debris when using compressed air, wear adequate eye protection (face shield or safety goggles) and do not exceed 276 kPa (40 psi) air pressure.

2. Remove the debris by blowing them through with compressed air or spraying them out with water. Work from the rear of the radiator (in the opposite direction of the normal cooling air flow).

3. Drain the coolant when the engine is cold. For detailed procedures, see the vehicle/chassis maintenance manual. For types of coolant, refer to the “Service Products” section.
4. If the HVAC unit is connected to the cooling system, open the regulating valves all the way.

Degreasing

Degrease as follows:

1. Fill the cooling system with a 5% solution (1.6 ounces per quart of water—50 grams per liter) of a mildly alkaline cleaning agent, such as sodium carbonate.
2. Run the engine at moderate speed until the thermostat starts to open, at an operating temperature of approximately 80°C (176°F). Then run it for about five minutes longer. Shut down the engine and allow it to cool to approximately 50°C (112°F).



WARNING: **HOT COOLANT**

To avoid scalding from the expulsion of hot coolant, never remove the cooling system pressure cap while the engine is at operating temperature. Wear adequate protective clothing (face shield, rubber gloves, apron, and boots). Remove the cap slowly to relieve pressure.

3. Drain all the cleaning solution.
4. Flush the cleaning solution from the cooling system.
 - [a] Immediately after draining the cleaning solution, flush the system with clean water.
 - [b] Once the clean water has drained, fill the system again with clean water.
 - [c] Run the engine. Allow the engine to warm up to approximately 80°C (176°F), and then run it about five minutes longer.
 - [d] Drain the hot water.
5. Fill the cooling system with new coolant. For detailed procedures, see the vehicle/chassis maintenance manual. For types of coolant, refer to the “Service Products” section.

Storage

Required protective measures for the MBE 4000 engine depend on the following:

- The length of time that the engine will be out of service
- The climate and conditions where the engine is stored

After cleaning, engines should, whenever possible, be placed in a dry, well-ventilated place.

In all cases, protect the engine against direct exposure to moisture (rain/splash water).

If the engine is to be out of service for 12 months or less, anticorrosion measures are not necessary, provided that the place of storage are dry and well-ventilated as described above.

If the engine is to be out of service for over 12 months, or under extraordinary storage or transportation conditions, then special protective measures are necessary. Information is available from any authorized dealer. It is strongly recommended that you request this information.

NOTE:

If the engine is to be out of service for over 18 months, the oil must be changed before the engine can be brought back into service.

TROUBLESHOOTING

In addition to operating the engine carefully and maintaining it properly, make sure to correct any malfunction promptly.

Emergency Starting

For emergency starting procedures (jump starting), see the driver's manual under the heading "Emergency Starting With Jumper Cables."

Troubleshooting the Electronic Engine Control System

When the electronic engine control system detects a fault, it broadcasts a message on the datalink. The dash display will show the code "ECU 128," indicating there is an engine fault.

Important: To read the complete fault code, bring the vehicle to an authorized dealer. Complete fault codes can be read using minidiag2, the Nexiq DDR or DDDL PC software.

For fault codes and their meanings, see the next section in this guide.

General Troubleshooting

The tables that follow are designed to identify the causes of common problems, suggest further checks and appropriate remedies. When dealer service is necessary, this is mentioned in the table.

NOTE:

Remember to follow all cautions when troubleshooting the engine.

| Problem - The Engine Will Not Crank | |
|---|--|
| Cause | Remedy |
| The batteries are damaged or weak. | Test the batteries. Replace them, if needed. |
| The ignition switch is damaged. | Replace the ignition switch. |
| The battery cables are damaged and/or corroded. | Replace the battery cables. |
| The starter is damaged and/or worn. | Have an authorized dealer replace the starter. |
| The clutch or transmission is damaged. | Bring the vehicle to an authorized dealer for service. |
| There is internal damage to the engine. | Bring the vehicle to an authorized dealer for service. |

| Problem—The Engine Turns Over Slowly | |
|--|---|
| Cause | Remedy |
| The batteries are damaged or weak. | Test the batteries. Replace them, if needed. |
| The ignition switch is damaged. | Replace the ignition switch. |
| The battery cables are damaged and/or corroded | Replace the battery cables. |
| The starter is damaged and/or worn. | Have an authorized dealer replace the starter. |
| The engine oil does not meet the correct specifications. | Change the engine oil, using the correct type of oil. |
| The transmission fluid does not meet the correct specifications. | Change the transmission fluid, using the correct type of fluid. |

| Problem—The Engine Cranks, But Won't Start | |
|---|---|
| Cause | Remedy |
| The batteries are damaged or weak. | Test the batteries. Replace them, if needed. |
| The cranking speed is not set correctly. | Bring the vehicle to an authorized dealer for service. |
| No intake air preheater is installed, and it is too cold to start without one. | Install an intake air preheater. |
| The intake air preheater is malfunctioning. | Check the intake air preheater, and replace it, if necessary. |
| The camshaft TDC sensor and/or the crank angle position sensor are out of adjustment. | Push both sensors into their holes as far as they will go. If this does not solve the problem, bring the vehicle to an authorized dealer for service. |
| The camshaft TDC sensor and/or the crank angle position sensor are damaged. | Bring the vehicle to an authorized dealer for service. |
| There is air in the fuel system. | Check the fuel lines for air pockets. Bleed the fuel system and start the engine. |
| The air filter is clogged. | Clean or replace the air filter. |
| The fuel filter is clogged. | Replace the filter element. |
| The exhaust brake valve is malfunctioning. | Have an authorized dealer check the operation of the valve. |
| The valves are not adjusted properly. | Check the valve lash. |
| There are other problems in the fuel system. | Bring the vehicle to an authorized dealer for service. |

| Problem—The Engine Starts Only After Cranking for a Long Time | |
|---|---|
| Cause | Remedy |
| The fuel tank is low or empty. | Add fuel and bleed the fuel system, if necessary. |
| There are leaks in the fuel lines. | Check the fuel lines for leaks and repair them, if necessary. |
| The fuel filter is clogged. | Replace the filter element. |
| The fuel line, the fuel prefilter, or the screen in the fuel tank is blocked. | Clean and bleed the system. Have the fuel lines and filters checked by an authorized dealer. |
| The camshaft TDC sensor and/or the crank angle position sensor are out of adjustment. | Push both sensors into their holes as far as they will go. If this does not solve the problem, bring the vehicle to an authorized dealer for service. |
| The camshaft TDC sensor and/or the crank angle position sensor are damaged. | Bring the vehicle to an authorized dealer for service. |
| There are other problems in the fuel system. | Bring the vehicle to an authorized dealer for service. |

| Problem—The Engine Starts, But Dies | |
|---|---|
| Cause | Remedy |
| The fuel tank is low or empty. | Add fuel and bleed the fuel system, if necessary. |
| The fuel filter is clogged. | Replace the filter element. |
| The fuel line, the fuel prefilter, or the screen in the fuel tank is blocked. | Clean and bleed the system. Have the fuel lines and filters checked by an authorized dealer. |
| The camshaft TDC sensor and/or the crank angle position sensor are out of adjustment. | Push both sensors into their holes as far as they will go. If this does not solve the problem, bring the vehicle to an authorized dealer for service. |
| The camshaft TDC sensor and/or the crank angle position sensor are damaged. | Bring the vehicle to an authorized dealer for service. |
| The constant-throttle valves are malfunctioning. | Bring the vehicle to an authorized dealer for service. |
| There are other problems in the fuel system. | Bring the vehicle to an authorized dealer for service. |

| Problem—The Engine Fan Doesn't Work | |
|---|---|
| Cause | Remedy |
| The fan hub is damaged. | Replace the fan hub. |
| The fan wiring is damaged. | Repair the fan wiring. |
| The parameter settings in the DDEC-ECU or DDEC-VCU are incorrect. | Have an authorized dealer reprogram the control unit. |

| Problem—The Engine Fan Is Constantly On | |
|---|---|
| Cause | Remedy |
| The fan override switch is on. | Check the operation of the fan override switch. |
| The fan hub is damaged. | Replace the fan hub |
| The parameter settings in the DDEC-ECU or DDEC-VCU are incorrect. | Have an authorized dealer reprogram the control unit. |
| AC switch is damaged | Check AC switch. |

| Problem—Fuel Consumption Is Too High | |
|---|---|
| Cause | Remedy |
| The tires are not properly inflated. | Check all tires for correct pressure. |
| The air filter and/or intake air system is clogged. | Check the air restriction indicator. Clean the intake air system and replace the air filter if necessary. |
| The fuel filter is clogged. | Replace the filter element. |
| The exhaust brake valve is malfunctioning. | Have an authorized dealer check the operation of the valve. |
| The engine performs poorly, or does not develop full power. | The remedies are listed in "The Engine Performs Poorly, Does Not Develop Full Power." |

| Problem—The Engine Performs Poorly, Does Not Develop Full Power | |
|--|---|
| Cause | Remedy |
| The air filter and/or intake air system is clogged. | Check the air restriction indicator. Clean the intake air system and replace the air filter if necessary. |
| The exhaust brake valve is malfunctioning. | Have an authorized dealer check the operation of the valve. |
| The fuel filter is clogged. | Replace the filter element. |
| There are other problems with the fuel system. | Bring the vehicle to an authorized dealer for service. |
| The valves are not adjusted properly | Check the valve lash. |
| The coolant temperature sensor is damaged or reading incorrectly. | Bring the vehicle to an authorized dealer for service. |
| The fuel temperature sensor is damaged or reading incorrectly. | Bring the vehicle to an authorized dealer for service. |
| The engine oil temperature sensor is damaged or reading incorrectly. | Bring the vehicle to an authorized dealer for service. |
| The charge-air temperature sensor is damaged or reading incorrectly. | Bring the vehicle to an authorized dealer for service. |
| There are problems with the DDEC-ECU or DDEC-VCU. | Bring the vehicle to an authorized dealer for service. |
| There is internal damage to the engine. | Bring the vehicle to an authorized dealer for service. |

| Problem—The Engine Is in Emergency Running Mode (constant speed 1,300 rpm) | |
|---|---|
| Cause | Remedy |
| The DDEC-ECU or DDEC-VCU is damaged. | Bring the vehicle to an authorized dealer for service. |
| An incorrect parameter is in the DDEC-ECU or DDEC-VCU. | Bring the vehicle to an authorized dealer and have the parameter settings reprogrammed in the DDEC-ECU or DDEC-VCU. |

| Problem—The Coolant Temperature Is Above Normal | |
|---|---|
| Cause | Remedy |
| The coolant level is too low. | Check for coolant leaks, and repair as needed. |
| The poly-V belt is loose. | Tighten or replace the poly-V belt. |
| The coolant temperature gauge and/or sensor is not reading correctly. | Bring the vehicle to an authorized dealer for service. |
| The radiator is damaged or dirty. | Clean the radiator. Repair or replace the radiator if necessary. |
| The coolant pump is damaged. | Have an authorized dealer replace the coolant pump. |
| The thermostat is damaged. | Have an authorized dealer replace the coolant pump. |
| The fan is not operating properly. | Bring the vehicle to an authorized dealer and have the fan hub checked or have the parameter settings reprogrammed in the DDEC-ECU or DDEC-VCU. |

| Problem—The Coolant Temperature Is Below Normal | |
|---|---|
| Cause | Remedy |
| The coolant temperature gauge and/or sensor is not reading correctly. | Bring the vehicle to an authorized dealer for service. |
| The thermostat is damaged. | Have an authorized dealer replace the thermostat. |
| The fan is not operating properly. | Bring the vehicle to an authorized dealer and have the fan hub checked. Bring the vehicle to an authorized dealer and have the parameter settings reprogrammed in the DDEC-ECU or DDEC-VCU. |

| Problem—The Cooling System Is Losing Coolant | |
|---|---|
| Cause | Remedy |
| There is an external coolant leak. | Repair the leaking component. |
| The radiator cap is leaking. | Replace the radiator cap. |
| The air compressor head is damaged. | Have an authorized dealer replace the air compressor. |
| The cylinder head gasket is leaking. | Have an authorized dealer replace the head gasket. |

| Problem—There Is Coolant in the Engine Oil | |
|---|--|
| Cause | Remedy |
| The cylinder head gasket is damaged. | Have an authorized dealer replace the head gasket. |
| The oil/water heat exchanger is leaking. | Have an authorized dealer replace the heat exchanger. |
| There is an internal coolant leak. | Bring the vehicle to an authorized dealer for service. |

| Problem—There Is Foam in the Engine Oil | |
|---|------------------------|
| Cause | Remedy |
| The oil level is too low or too high. | Correct the oil level. |
| The oil has not been changed within the recommended interval. | Change the oil. |
| The oil is not of the recommended quality. | Change the oil. |

| Problem—The Engine Oil Pressure Is Low | |
|--|--|
| Cause | Remedy |
| The oil pressure gauge and/or sensor is not reading correctly. | Bring the vehicle to an authorized dealer for service. |
| There is fuel in the oil. | Bring the vehicle to an authorized dealer for service. |
| The oil filter is clogged. | Replace the filter element. |
| The oil filter bypass valve is damaged. | Replace the bypass valve. |
| The oil pump and/or relief valve is damaged. | Have an authorized dealer replace the oil pump. |

| Problem—The Engine Exhaust Is White | |
|---|---|
| Cause | Remedy |
| The fuel is of poor quality. | Add fuel of the right quality. |
| The intake air preheater is malfunctioning. | Check the intake air preheater, and replace it, if necessary. |
| The valves are not adjusted properly. | Check the valve lash. |

| Problem—The Engine Exhaust Is Black | |
|---|---|
| Cause | Remedy |
| The air filter and/or intake air system is clogged. | Check the air restriction indicator. Clean the intake air system and replace the air filter if necessary. |
| The exhaust brake valve is malfunctioning. | Have an authorized dealer check the operation of the valve. |
| The intake air preheater is malfunctioning. | Check that the heater is not staying on all of the time. |
| The valves are not adjusted properly. | Check the valve lash. |
| There is damage to the fuel system: the fuel pump, one or more fuel injectors, or one or more unit pumps are damaged. | Bring the vehicle to an authorized dealer for service. |
| The charge-air temperature sensor is damaged. | Bring the vehicle to an authorized dealer for service. |
| There is internal damage to the engine. | Bring the vehicle to an authorized dealer for service. |

| Problem—The Engine Exhaust Is Blue | |
|---|--|
| Cause | Remedy |
| The engine oil level is too high (engine oil is reaching the combustion chamber). | Adjust the oil level, and then have the oil level checked by an authorized dealer. |
| The turbocharger is leaking oil. | Have an authorized dealer replace the turbocharger |
| The valve stem seals are loose or damaged. | Have an authorized dealer replace the seals. |
| The piston rings are worn. | Have an authorized dealer replace the piston rings. |

| Problem—Engine Brake Performance Is Poor | |
|---|---|
| Cause | Remedy |
| The engine brake control switch is damaged. | Replace the switch |
| The exhaust brake is not operating properly. | Have an authorized dealer check the operation of the valve. |
| The constant-throttle valves are malfunctioning. | Bring the vehicle to an authorized dealer for service. |
| Components of the DDEC-ECU and/or DDEC-VCU are damaged. | Bring the vehicle to an authorized dealer for service. |

| Problem—Cruise Control Is Not Working | |
|---|--|
| Cause | Remedy |
| One or more of the cruise control switches are damaged. | Replace the damaged switch. |
| Components of the DDEC-ECU and/or DDEC-VCU are damaged or not working properly. | Bring the vehicle to an authorized dealer for service. |

| Problem—The Battery Charge Indicator Light Does Not Come On When the Engine Is Not Running | |
|---|----------------------------------|
| Cause | Remedy |
| The bulb is damaged. | Change the bulb. |
| The circuit is broken. | Repair the break in the circuit. |

| Problem—The Battery Charge Indicator Light Comes On When the Engine is Running | |
|---|---|
| Cause | Remedy |
| The poly-V belt is too loose. | Check the belt tension; if necessary, have an authorized dealer replace the belt tensioner. |
| The belt tensioner is damaged. | Have an authorized dealer replace the belt tensioner. |
| The poly-V belt is worn or damaged. | Replace the belt. |
| The alternator is damaged (has a damaged rectifier or voltage regulator). | Have an authorized dealer replace the alternator. |

SERVICE PRODUCTS

Carefully match together the components of the engine with the lubricants they need. Use only brands which have been tested and approved by DDC. Information is available from any authorized dealer.

Do not use special lubricant additives. None are needed, and the use of additives could affect warranty.

Important: Dispose of service products in an environmentally responsible manner. This includes any parts which have been in contact with them (for example, filters). Reclaim them or recycle them, if possible, and be sure to comply with all legal disposal requirements.

Diesel Fuels

Use only commercially available vehicle diesel fuel. Grades such as marine diesel fuel, heating oil, and others are not permissible.

Do not use fuel additives. Using fuel additives could affect your warranty.

If using diesel fuel with a high sulphur content, exceeding 0.5 percent by weight, change the engine oil at shorter intervals.

Fuel added from drums or cans could be contaminated. This could lead to malfunctions in the fuel system.

Always filter the fuel before adding it to the tank.

For information about fuel in cold weather operation, see the heading "Winter-Grade Diesel Fuel" later in this chapter.

Flow Improvers

The effectiveness of flow improvers is not guaranteed with all fuels. Comply with the product manufacturer's recommendations. Any authorized dealer can provide information on approved flow improvers.

Kerosene

Keep the quantity added as low as possible, bearing in mind the outside temperature.

The addition of five percent by volume of kerosene will improve the fuel's resistance to cold by about 1°C (1.8°F). Never add more than 50 percent kerosene to the fuel.

NOTICE:

For safety reasons, add the kerosene to the diesel only in the fuel tank. Add the kerosene first, then the diesel. Run the engine for a short time to allow the mixture to reach all parts of the fuel system.

Engine Oils

The engine is delivered from the factory filled with an approved engine oil.

NOTICE:

The use of non-approved engine oils could affect warranty rights, and cause engine damage.

Only multigrade oils of American Petroleum Institute (API) service designation CI-4 will achieve proper performance for the cooled EGR engines. Look for the service mark printed on the oil container. See Figure 16.

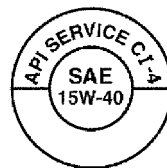

SAE Viscosity Grade: 15W-40
API Classification: CI-4

42541

Figure 16 API Lubricant Service Mark

When maintenance work is performed, record engine oil changes including details of the brand used, the quality category, and the Society of Automotive Engineers (SAE) viscosity rating of the oil. When topping off, use only engine oils of the correct API designation and SAE rating.

For information about oil in cold weather operation, see the heading "Low-Viscosity Engine Oil" later in this chapter.

Synthetic Oils

Synthetic oil may be used in MBE 4000 engines, provided they are of the correct API designation and viscosity, as required for non-synthetic oil.

Synthetic oil offers improved low-temperature flow properties and high-temperature resistance to oxidation. However, it is generally more costly than non-synthetic oil.

Review carefully the product information published by the synthetic oil manufacturer. Performance additive systems often respond differently in synthetic oil. Use of synthetic oil does not change the recommended oil change service interval.

Coolant

Coolant is a mixture of water and antifreeze. Under normal conditions, it is a mixture of 50 percent water and 50 percent antifreeze, but under extreme cold weather conditions, as much as 60 percent antifreeze can be added. For reasons of anticorrosion protection and to raise the boiling point, the coolant must remain in the cooling system all year round.

Regardless of mileage, replace the coolant every two years since the degree of corrosion protection gradually drops with time.

Fully-Formulated Antifreeze

Antifreeze approved for use in the MBE 4000 engine is a mixture of glycol compound (ethylene glycol), and corrosion inhibitors. Antifreeze

containing glycol compounds and corrosion inhibitors is known as fully-formulated antifreeze.

| |
|----------------|
| NOTICE: |
|----------------|

| |
|-------------------------------------|
| <u>Do not</u> use propylene glycol. |
|-------------------------------------|

Fully-formulated antifreeze has the following properties:

- It protects the radiator and engine from freezing.
- It provides protection against corrosion and cavitation for all components in the cooling system.
- It raises the boiling point of the coolant. This slows the rate of evaporation, avoiding coolant loss at high temperatures.

Water

Water containing no additives is not suitable as a coolant, even if no antifreeze protection is needed.

The water used in the coolant must comply with certain requirements, which are not always satisfied by drinking water. If water quality is inadequate, the water must undergo suitable treatment.

The following types of water are preferred for use in coolant:

- Distilled water
- Water purified by reverse osmosis

- De-ionized water

NOTICE:

In some areas, tap water can contain high levels of dissolved chlorides, sulfates, magnesium, and calcium, causing scale deposits, sludge deposits and/or corrosion. These deposits can damage the coolant pump and allow the engine to overheat.

the requirements of the Truck Maintenance Council (TMC). Coolant specifications are listed in Table 2.

Coolant Concentration

When topping off the cooling system after a drop in the coolant level, the concentration of corrosion-inhibiting antifreeze in the coolant must be 50 percent by volume. This affords protection down to a temperature of -37°C (-34°F). The cooling mixing ratio is listed in Table 3.

Coolant Specifications

To avoid damage to the cooling system, use only an approved corrosion-inhibiting antifreeze. Approved antifreeze must be fully-formulated and comply with

NOTE:

If the concentration is too low, there is risk of corrosion/cavitation in the cooling system.

| Type of Coolant | Requirement |
|----------------------------------|--|
| Fully-Formulated Ethylene Glycol | TMC RP-329 Type "A" |
| Water plus Corrosion Inhibitors | Temperature Must Not Fall Below 0°C (32°F) |

Table 2 Coolant Specifications

| Antifreeze Protection Down to $^{\circ}\text{C}$ ($^{\circ}\text{F}$) | Water % by Volume | Corrosion - Inhibiting Antifreeze % by Volume |
|---|-------------------|---|
| -37 (-34) | 50 | 50 |
| -52 (-62) | 40 | The cooling mix ratio is Max. 60 |

Table 3 Coolant Mixing Ratio

For information about coolant in cold weather operation, see the heading "Winter Coolant Antifreeze Protection" later in this chapter.

Supplemental Coolant Additives for Fully Formulated Coolant

The concentrations of some inhibitors will gradually deplete during normal engine operation. SCAs replenish the protection for cooling system components. The coolant must be maintained with the proper concentration of SCA. Detroit Diesel Power Cool maintenance SCAs are recommended.

NOTICE:

Failure to properly maintain coolant with SCA can result in damage to the cooling system and its related components. Conversely, over-concentration of SCA inhibitor can result in poor heat transfer, leading to engine damage. Always maintain concentrations at recommended levels. Do not use traditional SCAs with OAT coolant.

The proper application of SCA will provide:

- pH control
- Restored inhibitor levels to prevent corrosion

- Water-softening to deter formation of mineral deposits
- Cavitation protection to protect wet sleeve cylinder liners

Dropout

Excessive amounts of some corrosion inhibitors can cause a gel or crystalline deposit that reduces both heat transfer and coolant flow. This deposit is called "dropout."

Dropout takes the color of the coolant when wet, but becomes a white or gray powder when dry. It can pick up solid particles in the coolant and become gritty. It will cause premature wear of the coolant pump seals and other components of the cooling system.

The wet gel can be removed using an alkaline (non-acid) cleaner containing either sodium nitrite or sodium tetraborate.

If the gel is allowed to dry, it is necessary to disassemble the engine and clean it with a caustic solution, or physically clean the individual components.

Non-Approved Coolants

The following types of coolant are not approved for use in MBE 4000 engines:

- Antifreeze or coolant containing phosphate can cause dropout,

overheating, and damage to coolant pump seals.

- Automotive coolants offer no protection against liner pitting, and generally contain high levels of phosphate and silicate.
- Antifreeze based on methyl alcohol can damage the non-metallic components of the cooling system. They are not suitable for use with diesel engines because of their low boiling point.
- Antifreeze based on methoxy propanol is not compatible with the fluoroelastomer seals used in the cooling system.
- Glycol-based HVAC coolants contain phosphates which can deposit on hot internal engine surfaces and reduce heat transfer.

Recycled Antifreeze

Recycled antifreeze that complies with TMC RP-329 Type "A" (for ethylene glycol) is approved for use in MBE 4000 engines. The antifreeze must be recycled by distillation, reverse osmosis, or ion exchange.

Other recycled antifreeze, especially any antifreeze recycled by means of filtration processes, is not approved.

Corrosion Inhibitors

NOTICE:

Do not mix types of corrosion inhibitors. Do not add additional inhibitors to new, fully-formulated antifreeze, or coolant containing new, fully-formulated antifreeze. This can cause deposits or dropout in the cooling system.

The following types of corrosion inhibitors are approved for use in MBE 4000 engines:

- Supplemental Coolant Additives (SCAs)
- Organic Acid Technology (OAT) Inhibitors

Corrosion inhibitors are very important in maintaining engine life. All corrosion inhibitors protect against corrosion caused by acid, and cavitation of wet cylinder liners. SCAs also protect against mineral deposits.

The concentrations of some inhibitors will gradually diminish during normal engine operation. To protect the engine, nitrite concentration must be checked at regular intervals, and inhibitors added as necessary. The intervals are longer if OAT inhibitors are used.

NOTICE:

Always maintain inhibitor at the recommended level. Failure to properly maintain coolant with SCA can result in damage to the cooling system and related components. Over-concentration of SCA inhibitor can result in poor heating transfer and lead to engine damage.

The following types of inhibitor must not be used in MBE 4000 engines:

- Soluble oil additives cause poor heat transfer and lead to engine damage.
- Chromate additives can lead to the build-up of "green slime" (chromium dioxide) in the engine, leading to engine damage.

Disposal

Coolants are biologically degradable substances.

When disposing of used coolant, comply with local legal requirements and waste water regulations.

Consult the local water supply authorities to determine the best method of disposal.

A modern engine coolant has complex tasks to perform. Do not allow any form of "reprocessing" which consists only of mechanical purification.

Cold Weather Products

Special precautions must be taken during cold weather. To protect your engine, take the following special measures in cold weather.

- Use the recommended cold weather fuel and engine oil.
- Check the concentration of antifreeze in your coolant.
- Take special care of the batteries to ensure proper cranking amperage

Winter-Grade Diesel Fuel

At low outside temperatures, paraffin may separate from the diesel and affect its ability to flow freely. Avoid breakdowns caused by this problem (for example, blocked filters) by using cold-resistant winter-grade diesel fuel with improved low-temperature flow characteristics. In most cases, winter-grade fuel can be used without problems at cold outside temperatures.

If using summer-grade fuel or a less cold-resistant winter grade, a flow improver or kerosene can be added. The amount needed depends on the outside temperature.

Flow improver or petroleum spirit must be mixed with diesel fuel before its flow characteristics have been adversely affected by paraffin separation.

If changes have already been caused by paraffin separation, they can be corrected only by heating the entire fuel system.

Do not add anything to cold-resistant winter-grade diesel fuels. The fuel's low-temperature flow characteristics could actually deteriorate with additives.

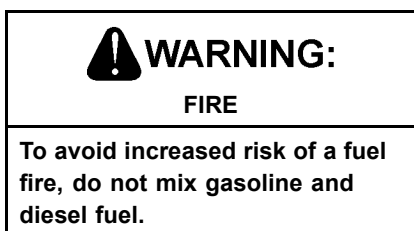

Low-Viscosity Engine Oil

When changing the engine oil, estimate the interval before your next oil change. Choose an oil from the SAE viscosity class which corresponds to the outside temperatures anticipated during this period of operation. See Figure 17.

Winter Coolant Antifreeze Protection

Before the temperature dips below freezing, check the concentration of antifreeze in the coolant. If necessary, increase it.

Do not increase the proportion (mixing ratio) of corrosion-inhibiting antifreeze beyond 55 percent by

volume (this gives the maximum antifreeze protection). Further increases in the mixing ratio would reduce the level of antifreeze protection and adversely affect the coolant's ability to dissipate heat.

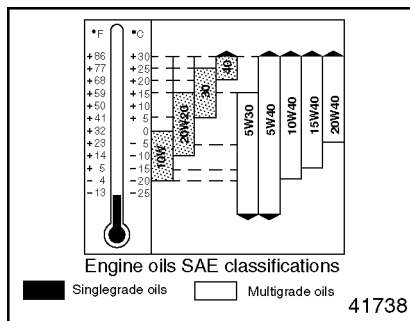

Figure 17 Engine Oil Temperature Ranges

Batteries

Batteries should receive more frequent maintenance and recharging during the cold season of the year. Careful maintenance and low current consumption will help to maintain the full battery charge. Starting capacity drops severely in cold weather. At -10°C (14°F) starting capacity is about 60 percent of normal. If the engine is shut down or out of use for an extended period of time, store the batteries out of the vehicle in a heated area if possible. Ensure good ventilation when recharging.

TECHNICAL DATA

General technical information is listed in Table 4.

| Description | MBE 4000 Engine |
|---|---|
| Engine Type | Vertical, inline cylinder block with turbocharger and charge-air cooler |
| Cooling System | Liquid Circuit |
| Combustion Principle | 4-Stroke direct-injection diesel |
| Number of Cylinders | 6 |
| Bore | 128 mm (5.04 in.) |
| Stroke | 166 mm (6.54 in.) |
| Displacement (total) | 12.816 liters (782 in ³) |
| Compression Ratio | 17.75:1 |
| Starting Speed | Approximately 100 rpm |
| Direction of Engine Rotation (viewed from flywheel) | Counterclockwise |
| Starter | Electric Motor |

Table 4 General Technical Information

Engine Data

The engine weights are listed in Table 5. The engine dimensions (ready for shipment) are listed in Table 6. Also see Figure 18 and Figure 19. Coolant capacities are listed in Table 7. Lubricating oil capacities are listed in Table 8.

| Dimension | Size |
|------------|-------------------------|
| Length (A) | 1338.7 mm (53.1 in.) |
| Width (B) | 1069.3 mm (42.1 in.) |
| Height (C) | 1130.3 mm (44.5 in.) |

| Engine | Engine Dry Weight |
|------------|-------------------|
| 6-Cylinder | 960 kg (2117 lb) |

Table 5 Engine Weights

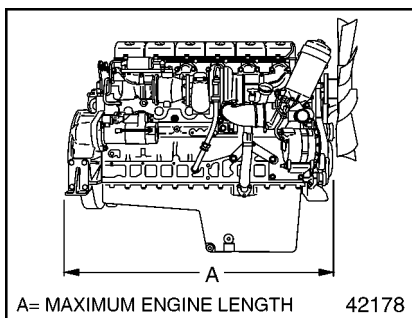

Figure 18 Side View

Table 6 Engine Dimensions

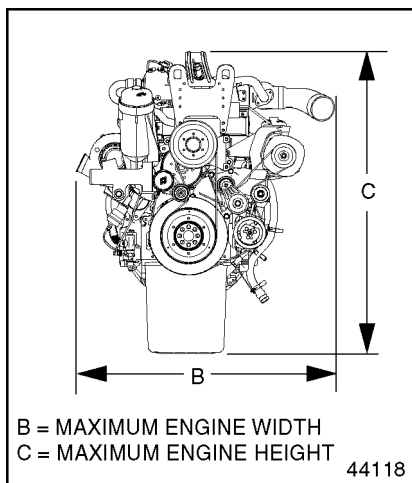

Figure 19 Front View

| Description | MBE 4000 Engine |
|-------------------|-------------------|
| Coolant Capacity* | Max. 70 L (74 qt) |

*Does not include capacity of cooling system.

Table 7 Coolant Capacity

| Description | Oil Pan Capacity | Oil System Fill Capacity † |
|---|-------------------|----------------------------|
| EGR engines w/front Sump * | 36 L (38 qts) | 39.5 L (41.7 qts) |
| Non-EGR Engines w/front Sump & Right Hand Drive Export Applications * | 36 L (38 qts) | 39.5 L (41.7 qts) |
| Rear Sump Applications | 40.0 L (42.3 qts) | 43.5 L (46.0 qts) |
| Non-EGR Engines w/front Sump & Left Hand Drive Applications | 40.0 L (42.3 qts) | 43.5 L (46.0 qts) |
| Front Sump Engine s/n 833529 and below | 40.0 L (42.3 qts) | 43.5 L (46.0 qts) |

* Engine s/n 833530 and above

† Including oil filter.

Table 8 Lubricating Oil Capacity

Testing and Adjusting Values

Valve lash checking and adjustments are listed in Table 9. Engine Oil

Pressure is listed in Table 10. Coolant thermostat conditions are listed in Table 11. Injector pressures are listed in Table 12.

| Valve Type | Check For: mm (in.) | Adjust To: mm (in.) |
|------------|-------------------------------|------------------------|
| Intake | 0.30 to 0.60 (0.012 to 0.024) | 0.40 (0.016) |
| Exhaust | 0.50 to 0.80 (0.020 to 0.032) | 0.60 (0.024) |

Table 9 Valve Lash Checking and Adjustment

| Engine Speed | Minimum Pressure |
|----------------|------------------|
| At idling rpm | 50 kPa (7 psi) |
| At maximum rpm | 250 kPa (36 psi) |

Table 10 Engine Oil Pressure

| Condition | Specification |
|----------------|---------------------------|
| Starts to open | 81 to 85°C (177 to 185°F) |
| Fully open | 95°C (203°F) |
| Minimum lift | 8 mm (0.3 in.) |

Table 11 Coolant Thermostat

| Opening Pressure | Value in kPa (Psi) |
|--------------------------|--------------------|
| Minimum opening pressure | 25500 (3698) |
| Maximum opening pressure | 27000 (3916) |

Table 12 Injector Pressures

MAINTENANCE

When performed on a regular basis, changing the engine oil and filters is the least costly way of obtaining safe and reliable vehicle operation. Added benefits and savings occur when you check that the valves, fuel injectors, and oil and cooling circuits are in good working order during oil changes.

The maintenance section of this manual explains when you should change your oil and what to look for when checking for wear or damage.

For additional information, please contact Detroit Diesel Technical Service.

Scheduled Intervals

All service intervals and maintenance operations are based on the parts and accessories expressly approved for your engine.

The scope and frequency of maintenance work are determined by the engine's operating conditions: severe duty, short haul, or long haul.

Evidence of regular maintenance is essential if a warranty claim has to be submitted.

If optional equipment is installed, be sure to comply with the maintenance requirements for these extra items.

Important: If the engine is stored for more than 18 months, the oil must be changed before the engine can be brought into service.

Maintenance Schedule Types

There are three types of maintenance schedule:

- Schedule I (Severe Service)
- Schedule II (Short Haul)
- Schedule III (Long Haul)

To determine which schedule to use, find the distance traveled by the vehicle in a year, regardless of vehicle type.

Severe Service — Applies to vehicles that annually travel up to 6000 miles (10,000 kilometers) or that operate under severe conditions. Examples of Severe Service usage include: operation on extremely poor roads or where there is heavy dust accumulation; constant exposure to extreme hot, cold, salt-air, or other extreme climates; frequent short-distance travel; construction-site operation; city operation (fire truck, garbage truck); or farm operation.

Short-Haul — Applies to vehicles that annually travel up to 60,000 miles (100,000 kilometers) and operate under normal conditions. Examples of Short-Haul usage are: operation primarily in cities and densely populated areas; local transport with infrequent freeway travel; or high percentage of stop-and-go travel.

Long-Haul — Long Haul (over-the-road transport) is for vehicles that annually travel more than 60,000 miles (100,000 kilometers), with minimal city or stop-and-go operation. Examples of Long-Haul usage are: regional delivery that is mostly freeway miles; interstate transport; or any road operation with high annual mileage.

Maintenance Schedule and Interval Operations — The three different schedules of vehicle usage (severe, short haul, and long haul) are listed in Table 13. For each schedule, the appropriate distance interval (in miles and kilometers) is given for performing and repeating each maintenance operation.

The descriptions of all maintenance operations, indicating all maintenance operation sets at which each operation must be performed are listed in Table 14, Table 15, and Table 16.

Maintenance Intervals — The three maintenance interval tables show which maintenance operation must be performed at the actual distances (in miles or kilometers) for each maintenance operation. The schedule of actual distances is based on the intervals given in the Maintenance Schedule Table (Table 13).

The three maintenance interval tables are:

- Maintenance Interval Table, Severe Service (Table 14)
- Maintenance Interval Table, Short Haul (Table 15)
- Maintenance Interval Table, Long Haul (Table 16)

Maintenance Operation Sets — Each Maintenance Operations Sets Table (M1 through M4) lists the descriptions of only those maintenance operations that must be performed at that maintenance operation set. Each maintenance operation set is listed in a separate Maintenance Operations Table.

The descriptions of all maintenance operations, and the maintenance operation sets at which each operation must be performed are listed in Table 17 and Table 18.

Schedule Use

Before placing your new vehicle in service, determine the correct maintenance intervals that apply to your intended use of the vehicle. Refer to the Maintenance Schedule Table to determine the distance interval at which each maintenance operation must be performed to comply with your vehicle's schedule.

When the vehicle reaches the actual distance given for an interval, refer to the Maintenance Interval Tables to find the Maintenance Operation Set that applies to that interval. Then perform the maintenance operations listed in the applicable Maintenance Interval Operation Table.

Complete each Maintenance Operation Set at the required interval. For example, when you have completed Maintenance Operation Set M3 under the 16th maintenance number listed in the Maintenance Interval Table, repeat the pattern. For the 17th maintenance, do Maintenance Operation Set M1, under the first maintenance number listed in the Maintenance Interval Table.

NOTE:

For Severe Service, the pattern repeats after 15 maintenance numbers, not 16 (as for Short Haul and Long Haul).

Maintenance Tables

| Maintenance Schedule | Maintenance Interval Operation | Maintenance Intervals | | |
|--|--|-----------------------|---------|---------|
| | | Frequency | Miles | Km |
| Schedule I (Severe Service) vehicles that annually travel up to 6,000 miles (10,000 km) | Maintenance 1 (M1) | every | 10,000 | 17,000 |
| | Optional oil centrifuge (change rotor) | every | 20,000 | 32,000 |
| | Maintenance 2 (M2) | every | 20,000 | 32,000 |
| | Maintenance 3 (M3) | first | 20,000 | 32,000 |
| then every | | 40,000 | 68,000 | |
| Schedule II (Short Haul) vehicles that annually travel up to 60,000 miles (100,000 km) | Maintenance 1 (M1) | every | 15,000 | 25 000 |
| | Optional oil centrifuge (change rotor) | every | 20,000 | 32,000 |
| | Maintenance 2 (M2) | every | 30,000 | 50,000 |
| | Maintenance 3 (M3) | first | 30,000 | 50 000 |
| | | then every | 60,000 | 100,000 |
| Maintenance 4 (M4) | every | 120,000 | 200,000 | |
| Schedule III (Long Haul) vehicles that annually travel more than 60,000 miles (100,000 km) | Optional oil centrifuge (change rotor) | every | 20,000 | 32,000 |
| | Maintenance 1 (M1) | every | 25,000 | 42,000 |
| | Maintenance 2 (M2) | every | 50,000 | 84,000 |
| | Maintenance 3 (M3) | first | 50,000 | 84,000 |
| | | then every | 100,000 | 167,000 |
| Maintenance 4 (M4) | every | 200,000 | 334,000 | |

Table 13 Maintenance Schedule Table

| Maint. No | Maintenance Interval | Miles | Km |
|-----------|----------------------|---------|----------|
| 1 | M1 | 10,000 | 17,000 |
| 2 | M1, M2 and M3 | 20,000 | 32,000 |
| 3 | M1 | 30,000 | 50,000 |
| 4 | M1 and M2 | 40,000 | 67,000 |
| 5 | M1 | 50,000 | 84, 000 |
| 6 | M1, M2 and M3 | 60,000 | 100, 000 |
| 7 | M1 | 70,000 | 117,000 |
| 8 | M1 and M2 | 80,000 | 134,000 |
| 9 | M1 | 90,000 | 150,000 |
| 10 | M1, M2 and M3 | 100,000 | 167,000 |
| 11 | M1 | 110,000 | 184,000 |
| 12 | M1 and M2 | 120,000 | 200,000 |
| 13 | M1 | 130,000 | 217,000 |
| 14 | M1, M2 and M3 | 140,000 | 234,000 |
| 15 | M1 | 150,000 | 250,000 |
| 16 | M1 and M2 | 160,000 | 267,000 |

Table 14 Maintenance Intervals for Schedule I, Severe Service

| Maint. No. | Maintenance Interval | Miles | Km |
|------------|----------------------|---------|---------|
| 1 | M1 | 15,000 | 25 000 |
| 2 | M1, M2, and M3 | 30,000 | 50,000 |
| 3 | M1 | 45,000 | 75,000 |
| 4 | M1, M2 and M4 | 60,000 | 100,000 |
| 5 | M1 | 75,000 | 125,000 |
| 6 | M1, M2 and M3 | 90,000 | 150,000 |
| 7 | M1 | 105,000 | 120,000 |
| 8 | M1 and M2 | 120,000 | 200,000 |
| 9 | M1 | 135,000 | 225,000 |
| 10 | M1, M2, and M3 | 150,000 | 250,000 |
| 11 | M1 | 165,000 | 275,000 |
| 12 | M1, M2 and M4 | 180,000 | 300,000 |
| 13 | M1 | 195,000 | 325,000 |
| 14 | M1 and M2 | 210,000 | 350,000 |
| 15 | M1 | 225,000 | 375,000 |
| 16 | M1, M2 and M3 | 240,000 | 400,000 |

Table 15 Maintenance Intervals for Schedule II, Short Haul

| Maint. No | Maintenance Interval | Miles | Km |
|-----------|----------------------|---------|---------|
| 1 | M1 | 25,000 | 42,000 |
| 2 | M1, M2, M3 and M4 | 50,000 | 84,000 |
| 3 | M1 | 75,000 | 125,000 |
| 4 | M1 and M2 | 100,000 | 167,000 |
| 5 | M1 | 125,000 | 209,000 |
| 6 | M1, M2, and M3 | 150,000 | 250 000 |
| 7 | M1 | 175,000 | 292,000 |
| 8 | M1 and M2 | 200,000 | 334,000 |
| 9 | M1 | 225,000 | 375,000 |
| 10 | M1, M2, M3 and M4 | 250,000 | 417,000 |
| 11 | M1 | 275,000 | 459,000 |
| 12 | M1 and M2 | 300,000 | 500,000 |
| 13 | M1 | 325,000 | 542,000 |
| 14 | M1, M2, and M3 | 350,000 | 584,000 |
| 15 | M1 | 375,000 | 625,000 |
| 16 | M1 and M2 | 400,000 | 667,000 |

Table 16 Maintenance Intervals for Schedule III, Long Haul

| Operation Description | M1 | M2 | M3 |
|--|-----------|-----------|-----------|
| Engine Inspecting | ✓ | ✓ | ✓ |
| Valve Lash Checking and Adjusting | — | — | ✓ |
| Fuel /Water Separator Prefilter Element Cleaning | ✓ | ✓ | ✓ |
| Main Fuel Filter Element Changing | — | ✓ | ✓ |
| Engine Oil and Filter Changing | ✓ | ✓ | ✓ |
| Coolant Concentration and Inhibitor Level Checking | ✓ | ✓ | ✓ |
| Coolant Flushing and Changing* | — | ✓ | ✓ |
| Cooling System Inspecting | ✓ | ✓ | ✓ |

* Coolant flushing and changing must be done at least every two years.

Table 17 Required Maintenance Operations Sets, Schedule I

| Maintenance Operation Description | M1 | M2 | M3 | M4 |
|---|----|----|----|----|
| Engine Inspecting | — | ✓ | ✓ | ✓ |
| Valve Lash Checking and Adjusting† | — | — | — | ✓ |
| Fuel /Water Separator Prefilter Element Cleaning | — | ✓ | ✓ | ✓ |
| Main Fuel Filter Element Changing | — | ✓ | ✓ | ✓ |
| Engine Oil and Filter Changing | ✓ | ✓ | ✓ | ✓ |
| Coolant Concentration and Inhibitor Level Checking | ✓ | ✓ | ✓ | ✓ |
| Coolant Flushing and Changing* | — | — | — | ✓ |
| Cooling System Inspecting | — | ✓ | ✓ | ✓ |
| Rear Engine Power Take-Off (REPTO) torsional damper checking‡ | — | — | — | ✓ |

* Coolant flushing and changing must be done at least every two years.

† For Schedule II and III, the valve lash checking and adjusting must be done first at 60,000 miles and then every M4.

‡ For Schedule II, the REPTO torsional damper checking must be done first at 60,000 miles or 3000 hours and then every 30,000 miles or 1500 hours.

Table 18 Required Maintenance Operations Sets, Schedule II and III

Required Maintenance Operations

The following sections describe the required maintenance operations listed in Table 17 and listed in Table 18.

Engine Inspecting

Inspect engine as follows:

1. Visually check the engine for signs of leakage. A slight dampness at the sealing points is no cause for concern.

NOTE:

More severe leaks, combined with a continual loss of oil, must be corrected without delay.

2. Visually inspect all lines and hoses. Listen for any sound of leaking. Make sure all pipes and hoses are undamaged, correctly positioned to avoid chafing, and properly secured.

Valve Lash Checking and Adjusting

A special engine cranking tool (J 46167) is required for this procedure.

NOTE:

Adjust the valve lash when the engine is cold. Wait at least 30 minutes after shutdown, even if the engine ran only a short time.

Gaining Access To The Valves —

Gain access to the valves as follows:

NOTE:

Clean the cylinder head covers before removing it.

1. Remove the cylinder head covers. See Figure 20.

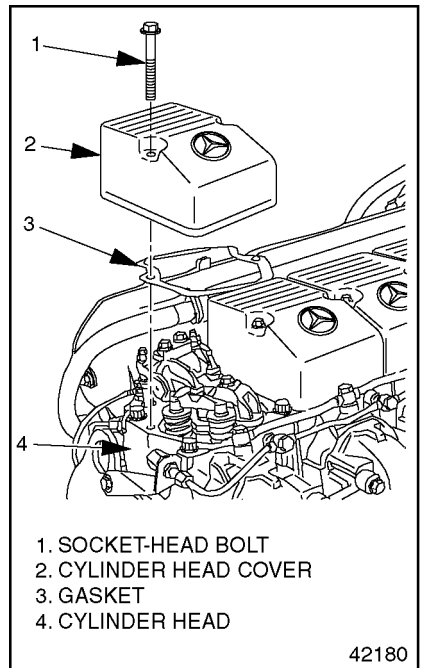

Figure 20 Cylinder Head Cover

2. Remove the inspection cover on the flywheel housing.

3. Fit the cranking tool into the inspection hole on the timing case. See Figure 21.

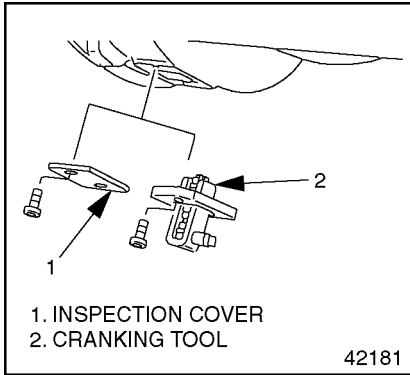

Figure 21 Placing Cranking Tool

Choosing A Method — Select a method for adjusting the valve lash. There are two acceptable methods for adjusting valve lash:

- In order, according to the timing sequence used for fuel injection (see "Method One—Adjust Each Cylinder In Firing Order")
- By type of valve, depending on crankshaft position (see "Method Two—Adjust All Valves Using Two Crankshaft Positions").

See Figure 22 for the cylinder and valve layout on the MBE 4000 engine.

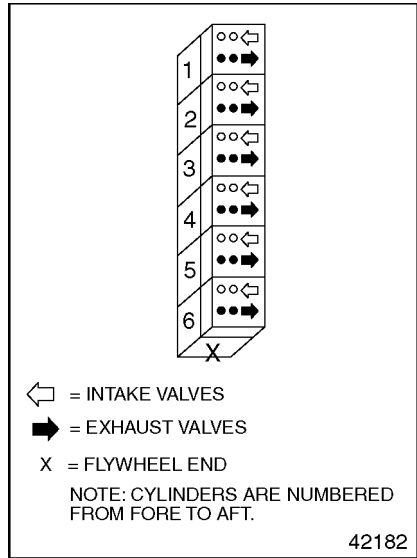

Figure 22 Cylinder and Valve Layout

Method One — Method one allows you to adjust each cylinder in the order in which fuel is injected. The crankshaft must be repositioned after each cylinder is adjusted as listed in Table 19.

1. For each cylinder, use the cranking tool to turn over the crankshaft until the piston is exactly at top dead center (TDC) in the compression stroke. The valves must be closed and it must be possible to turn the push rods without effort.

NOTE:

When the piston in cylinder #1 is at ignition TDC, the valves of cylinder #6 will overlap, meaning that both intake and exhaust valves are partially open, and show no measurable play when tested with a feeler gauge.

2. Check each valve and adjust it (if necessary), using the procedures under the headings "Checking Valve Lash" and "Adjusting Valve Lash."

| Engine | Crankshaft Position | Cylinders | | | | | |
|----------|---------------------|-----------|---|---|---|---|---|
| | | 1 | 5 | 3 | 6 | 2 | 4 |
| MBE 4000 | Ignition TDC | 1 | 5 | 3 | 6 | 2 | 4 |
| | Valve Overlap | 6 | 2 | 4 | 1 | 5 | 3 |

Table 19 Valve Adjustment — Method One

Method Two — Method two allows you to adjust all the valves using just two crankshaft positions.

1. Using the cranking tool, turn the crankshaft until cylinder #1 is at the ignition TDC position (all valves are closed) and cylinder #6 is at the valve overlap position (all valves are open).
2. Check the valves listed in Table 20 in the "Ignition TDC" row of and adjust them (if necessary), using the procedures under the headings "Checking Valve Lash" and "Adjusting Valve Lash."
3. Using the cranking tool, turn the crankshaft until cylinder #6 is at the ignition TDC position (all valves are closed) and cylinder #1 is at the valve overlap position (all valves are open).
4. Using the same procedure, check the valves listed in Table 20 in the "Valve Overlap" row and adjust them (if necessary), using the procedures under the headings "Checking Valve Lash" and "Adjusting Valve Lash."

| Engine | Cylinder #1 Crankshaft Position | Cylinder Valve Types* | | | | | |
|----------|---------------------------------|-----------------------|---|---|---|---|-----|
| | | 1 | 2 | 3 | 4 | 5 | 6 |
| MBE 4000 | Ignition TDC | I/E | I | E | I | E | — |
| | Valve Overlap | — | E | I | E | I | I/E |

*I = Intake Valve, E = Exhaust Valve

Table 20 Valve Adjustment — Method Two

Adjusting Valve Lash — Adjust valve lash as follows:

1. If adjustment is needed, loosen the locknut. See Figure 23.

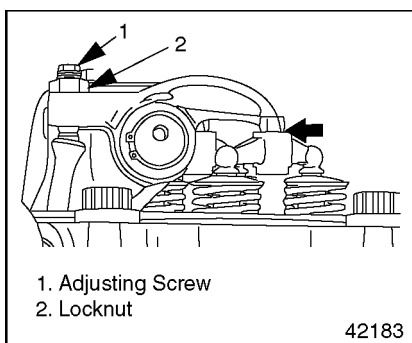

Figure 23 Valve Lash Adjustment

2. Turn the adjusting screw until the valve lash is correct. Use the exact settings listed in Table 21.

NOTE:

When adjusting the valves, adjust to the exact setting. Use the range only for checking adjustment.

3. Tighten the locknut 50 N·m (37 lb·ft).
4. Check the valve lash again. Adjust again if necessary.

Restoring The Vehicle To Operating Condition —

Restore the vehicle to operation condition as follows:

1. Install the cylinder head covers.
2. Remove the cranking tool from the inspection hole in the flywheel housing.
3. Replace the end cover on the inspection hole and tighten the bolts 25 N·m (18 lb·ft).

| Valve Type | Check For : (mm (in.)) | Adjust To: (mm (in.)) |
|------------|-------------------------------|--------------------------|
| Intake | 0.30 to 0.60 (0.012 to 0.024) | 0.40 (0.016) |
| Exhaust | 0.50 to 0.80 (0.020 to 0.032) | 0.60 (0.024) |

Table 21 Valve Lash Adjustment

Fuel/Water Separator Prefilter Element Cleaning

Clean the prefilter element as follows:

1. Loosen the bleed screw.
See Figure 24.
2. Unscrew the drain plug and drain the fuel in the prefilter.
3. Twist off the sight bowl and remove the filter element from the separator head.
4. Separate the sight bowl from the filter element. Clean the sight bowl. Discard the old filter element and both O-rings.
5. Replace the filter element and O-rings.
6. Assemble the sight bowl and the prefilter element.
 - [a] Lubricate one O-ring with a light coating of engine oil and insert it into the sight bowl.
 - [b] Screw the prefilter element and sight bowl together.
7. Assemble the prefilter element and the separator head.
 - [a] Lubricate the other O-ring with a light coating of engine oil and insert it into the open end of the prefilter element.
 - [b] Screw the prefilter element onto the separator head and

tighten firmly, using hands only.

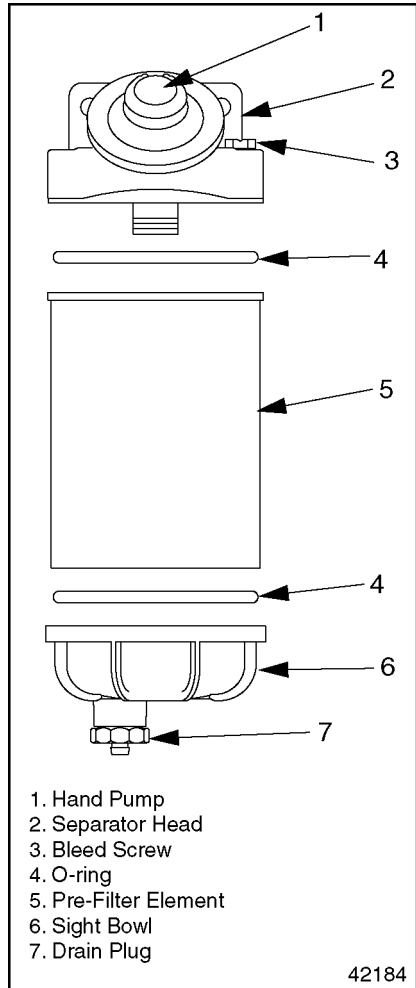

Figure 24 Fuel/Water Separator

NOTE:

Do not use tools to tighten the prefilter element.

8. Tighten the drain plug.

9. Prime the fuel system.

[a] If equipped with a hand pump on the fuel/water separator, work the hand pump 50 times.

NOTE:

There should be a strong resistance in the hand pump, caused by the pressure build-up within the fuel system.

[b] Crank the engine for 30 seconds at a time, but no longer. Before cranking the engine again, wait at least two minutes. The engine should start within four 30 second attempts.

Fuel Pro® 382 Fuel/Water Separator Element Replacement

Replace the fuel/water separator element as follows:

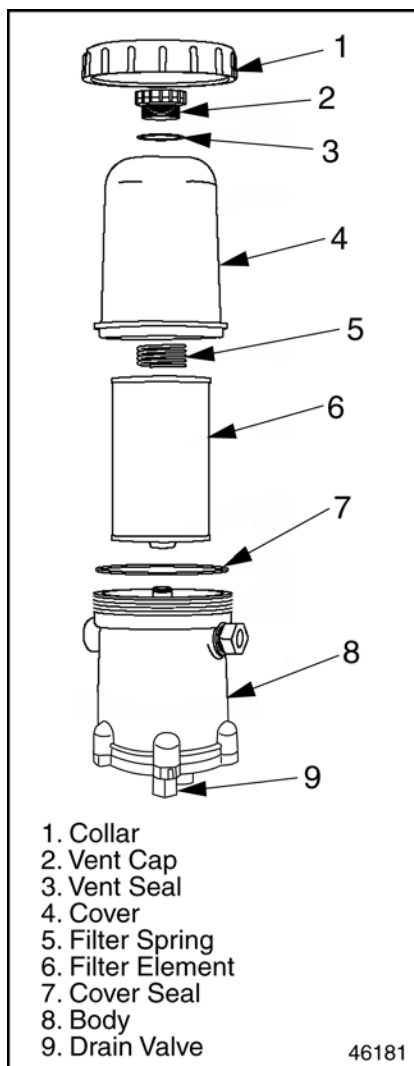

Figure 25 Fuel Pro® 382 Fuel/Water Separator

1. Remove the vent cap, open the drain valve and drain fuel into approved container, until level is below the collar. See Figure 25.
2. Using a collar wrench remove collar and cover.
3. Remove the filter element from the separator head and discard filter and O-rings. Dispose of filter properly.
4. Clean the cover and the mounting surface on the body.
5. Install the filter element with bottom grommet, new cover O-ring, cover and collar. Hand tighten only.
6. Fill cover half-way with clean fuel through the vent cap opening.
7. Replace O-ring on the vent cap and install in cover. Hand tighten only.

NOTE:

Do not use tools to tighten the collar or vent cap.

8. Tighten the drain plug.
9. Crank the engine for 30 seconds at a time, but no longer. Before cranking the engine again, wait at least two minutes. The engine should start within four, 30 second attempts.

10. Start the engine and raise the rpm for one minute to purge the air. After the air is purged stop the engine, loosen the vent cap until the fuel level lowers to just above the collar. Tighten the vent cap by hand. Check for leaks.

Main Fuel Filter Element Changing

Change the main fuel filter element as follows:

1. Open the fuel tank fill cap to release pressure in the fuel system. Replace and tighten the cap.
2. Clean the outside of the fuel filter housing (see Figure 26).

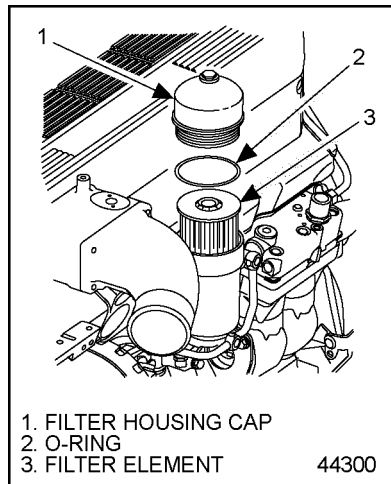

Figure 26 Main Fuel Filter

3. Using a 36-mm socket, unscrew the cap on the main fuel filter housing. Remove the cap and lift the filter element a short distance within the filter housing allowing the fuel to drain off the filter.
4. Remove the filter element from the cap and clean the filter cap. Discard the filter element and the O-ring from the cap.
9. Install a new O-ring on the filter cap and screw the cap onto the filter housing. Tighten the cap to 25 N·m (18 lb·ft).
10. If equipped with a hand pump on the fuel/water separator, work the hand pump until resistance is felt.

| |
|----------------|
| NOTICE: |
|----------------|

| |
|--|
| To prevent damage to the filter housing, do not allow dirt to get into the filter housing. |
|--|

5. Clean the filter housing cap.
6. Replace the O-ring.
7. Lubricate the filter element rubber seal with a light coat of fuel oil and insert it into the filter housing. Push down and rotate the filter element while installing to ensure it is seated properly at the base of the housing.

NOTE:

A properly seated filter element will hold the fuel in the filter housing and prevent it from draining back to the tank. If the fuel does not stay in the housing the element is not seated properly, repeat steps 1 and 2.

8. Fill fuel filter housing with clean fuel oil.

NOTE:

There should be a strong resistance in the hand pump, caused by the pressure build-up within the fuel system.

11. Crank the engine for 30 seconds at a time, but no longer. Before cranking again, wait at least two minutes, then crank again. The engine should start within four 30-second attempts.
12. Once the engine starts allow it to idle for at least one minute or until idle is smooth before applying the throttle. Check the fuel filter housing for leaks.

Engine Oil and Filter Changing

Select the SAE class (viscosity) on the basis of the average air temperature for the season (see Figure 27).

NOTE:

Continued use of a single SAE class will result in frequent oil changes. For this reason, view the temperature ranges for the various SAE classes.

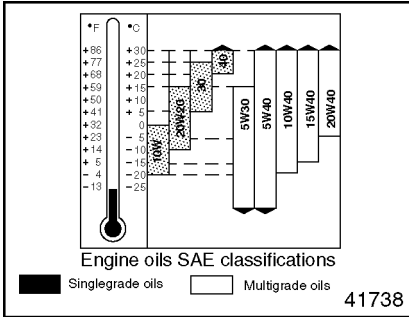

Figure 27 Engine Oil Temperature Ranges

To ensure the engine is protected and the oil stays clean until the next oil change, use only oils of API classification CI-4.

Drain oil as follows:

1. Chock the tires, place the transmission in neutral, and set the parking brake.

NOTE:

Change the engine oil only when the engine is at a temperature of approximately 60°C (140°F).

2. Using a 36-mm socket, unscrew the oil filter cap (see Figure 28).

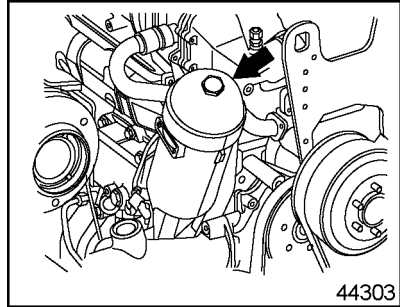

Figure 28 Oil Filter Cap

! WARNING:

FIRE

To avoid injury from fire, keep open flames, sparks, electrical resistance heating elements, or other potential ignition sources away when draining lubrication oil. Do not smoke when draining lubricating oil.

3. Drain the oil.
 - [a] Place a suitable receptacle beneath the oil drain plug on the underside of the oil pan.
 - [b] Carefully unscrew the oil drain plug on the oil pan and allow the oil to drain out (see Figure 29).

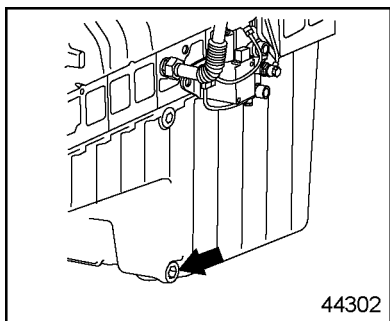

Figure 29 Engine Oil Drain Plug, Oil Pan

[c] Discard the O-ring on the oil drain plug.

4. Remove both the filter cap and the filter element. To release the filter element, twist the lower edge of the filter element to the side (see Figure 30).

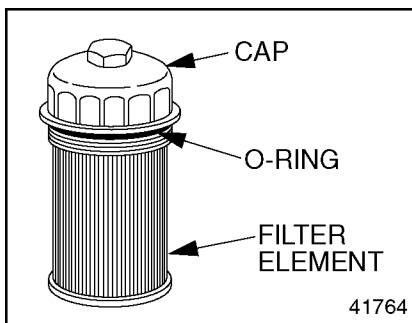

Figure 30 Cap with Oil Filter Element

NOTICE:

To prevent damage to the filter housing, ensure that no foreign objects get inside it. Do not wipe clean the filter housing.

5. Replace the O-ring on the cap (see Figure 30).
6. Install the new filter into the cap. Make sure the filter element is securely in place.
7. Screw the cap onto the oil filter housing. Tighten the cap 45 N·m (33 lb·ft).
8. Install the oil drain plug, using a new O-ring. Tighten the plug 80 N·m (60 lb·ft).



WARNING:

PERSONAL INJURY

To avoid injury from slipping and falling, immediately clean up any spilled liquids.

9. Add new engine oil through the oil fill (see Figure 31) until the maximum fill level on the oil dipstick has been reached. Engine fill capacity is 44 L (46 qts).

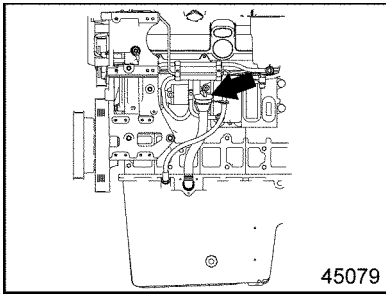

Figure 31 Oil Fill



CAUTION:

To avoid injury when working near or on an operating engine, remove loose items of clothing, jewelry, tie back or contain long hair that could be caught in any moving part causing injury.

10. Start the engine with the accelerator pedal in the idle position. Monitor the oil pressure gauge.

NOTICE:

Keep the engine running at idling speed until an oil pressure reading is obtained. If no oil pressure is shown after approximately 10 seconds, stop the engine and determine the cause. Failure to do so could result in engine damage.

11. Check the filter and oil drain plug for signs of leakage.
12. Stop the engine. Check the oil level again after approximately five minutes. If necessary, add oil up to the maximum fill level on the oil dipstick.

Optional Oil Centrifuge — Every 20,000 miles (32,000 km) change the oil centrifuge rotor as follows:

1. Remove the cover of the oil centrifuge.
2. Lift out the dirty rotor and replace it with a clean one (see Figure 32).

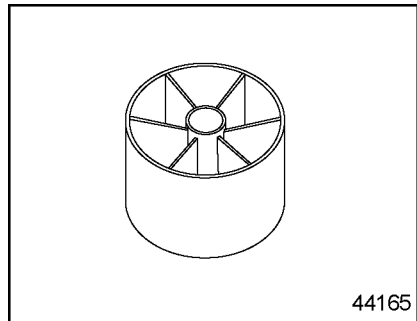



Figure 32 Rotor

3. Replace the centrifuge cover.

Coolant Concentration and Inhibitor Level Checking

Check the coolant concentration as follows:

| |
|--|
|  WARNING: HOT COOLANT |
| <p>To avoid scalding from the expulsion of hot coolant, never remove the cooling system pressure cap while the engine is at operating temperature. Wear adequate protective clothing (face shield, rubber gloves, apron, and boots). Remove the cap slowly to relieve pressure.</p> |

NOTE:

Check and correct the coolant level only when the coolant temperature is below 50°C (122°F).

1. Open the cap on the surge tank slowly, to allow excess pressure to escape. Set the cap aside.
2. Before adding coolant, use a suitable tester to check the concentration of corrosion-inhibiting antifreeze. If the concentration is lower than 50 percent by volume, drain coolant/add antifreeze until the concentration is correct. The coolant mixing ratio is listed in Table 22.

| Antifreeze Protection Down to °C (°F) | Water Percentage by Volume | Corrosion-Inhibiting Antifreeze Percentage by Volume |
|---------------------------------------|----------------------------|--|
| -37 (-34) | 50 | 50 |
| -52 (-62) | 40 | Maximum 60* |

*Concentrations of 60 percent affords the maximum antifreeze protection. Higher concentrations adversely affect heat dissipation.

Table 22 Coolant Mixing Ratio

NOTE:

When topping off, use only a pre-prepared coolant mixture containing a 50 percent concentration by volume of corrosion-inhibiting antifreeze.

NOTICE:

If the concentration of antifreeze is too low, there is a risk of corrosion or cavitation in the cooling system.

3. Check the coolant level and add more coolant if necessary.

Coolant Inhibitor Test

Intervals — Coolant inhibitor level should be checked at the intervals listed in Table 23.

If topping off is needed, add coolant which is identical to the initial fill coolant.

Check the nitrite concentration at regular intervals as listed in Table 24 with a *POWER Trac*® 3-Way Test Strip. Nitrite levels must be within 800–2400 PPM. Additional SCA must be added to the coolant when it becomes depleted, as indicated by a nitrite concentration of 800 PPM or less. If the nitrite concentration is greater than 800 PPM, do not add additional SCA. If the nitrite concentration is above 2400 PPM, the system is over-inhibited and should be partially drained and filled with a 50/50 mix of water and EG.

NOTE:

Drain intervals listed in Table 24 are dependent on proper maintenance.

| Service Application | Inhibitor Test Interval |
|---|---|
| On-highway Trucks and Motor Coaches | 20,000 Miles (32,000 Kilometers) |
| City Transit Coaches, Pick-up and Delivery Short Trip, and Emergency Vehicles | 6,000 Miles (9,600 Kilometers) or three months, whichever comes first |
| Industrial, Continuous Duty Generator Set, and all Other Applications | 500 Hours or three months, whichever comes first |
| Standby Generator Set | 200 Hours or yearly, whichever comes first |

Table 23 Required Coolant Inhibitor Test Intervals

| Coolant | Maintenance Interval | Action |
|---|--|--|
| Antifreeze/Water + SCA Inhibitor (DDC Power Cool) | A. 20,000 miles (32,000 km) or 3 months B. 500 hours or 3 months | Test nitrite concentration with test strip, add SCA or dilute coolant as needed. |
| | A. 300,000 miles (480,000 km) or 2 years B. 2 years or 4,000 hours | Drain and clean system. Replace with new coolant. |
| Ethylene Glycol/Water + SCA Inhibitor | A. 20,000 miles (32,000 km) or 3 months B. 500 hours or 3 months | Drain and clean system. Replace with new coolant. |
| | A. 300,000 miles (480,000 km) or 2 years B. 2 years or 4,000 hours | Drain and clean system. Replace with new coolant. |
| Ethylene Glycol/Water + OAT Inhibitor | A. 300,000 miles (480,000 km) or 2 years B. 5,000 hours | Add Power Cool Plus Extender |
| | A. 600,000 miles (960,000 km) or 4 years B. 4 years or 10,000 hours | Drain and clean system. Replace with new coolant. |
| Water Only + SCA Inhibitor | A. 20,000 miles (32,000 km) or 3 months B. 500 hours or 3 months | Drain and clean system. Replace with new coolant. |
| | A. 300,000 miles (480,000 km) or 2 years B. 2 years or 4,000 hours | Drain and clean system. Replace with new coolant. |
| Water Only + OAT Inhibitor | A. 300,000 miles (480,000 km) or 2 years B. 5,000 hours | Add Power Cool Plus Extender |
| | A. 600,000 miles (960,000 km) or 4 years B. 4 years or 10,000 hours | Drain and clean system. Replace with new coolant. |

A = On-highway trucks and motor coaches, city transit coaches, pickup and delivery, short trip, and emergency vehicles.

B = Industrial, generator set, and other applications

Table 24 Nitrite Interval Checks

Inhibitor Level Checking — Use Detroit Diesel *POWER Trac*®3-way Coolant Test Strips to measure nitrite and glycol concentrations. Cavitation/corrosion protection is indicated on the strip by the level of nitrite concentration. Freeze/boil-over protection is determined by glycol concentration.

Check the inhibitor level as follows:

| |
|---|
|  WARNING: HOT COOLANT |
| To avoid scalding from the expulsion of hot coolant, never remove the cooling system pressure cap while the engine is at operating temperature. Wear adequate protective clothing (face shield, rubber gloves, apron, and boots). Remove the cap slowly to relieve pressure. |

1. Dip the test strip into the coolant for one second, then remove it. Shake the strip vigorously to remove excess liquid.
2. Immediately compare the end pad to the color chart on the container to determine the glycol concentration.
3. Sixty seconds (one minute) after dipping, compare the nitrite pad to the color chart on the container to determine the nitrite concentration.
4. If the additive indicator (middle pad) shows any color change, this indicates the presence of an unauthorized inhibitor.
5. If there is any doubt about the quality of the coolant, change the coolant.
6. After each use, replace and tighten the cap on the test strip container. Discard any test strips that have turned light pink or tan in color.
7. Close and tighten the cap on the surge tank.

Coolant Flushing and Changing

Flush and change the coolant as follows:

WARNING:

HOT COOLANT

To avoid scalding from the expulsion of hot coolant, never remove the cooling system pressure cap while the engine is at operating temperature. Wear adequate protective clothing (face shield, rubber gloves, apron, and boots). Remove the cap slowly to relieve pressure.

1. Open the cap on the surge tank slowly, to allow excess pressure to escape. Set the cap aside.
2. Open the water regulating valve for the heating system.
3. Place a large receptacle underneath the coolant drain plug and open the coolant drain plug on the bottom of the radiator. See Figure 33.

NOTE:

Make sure the coolant can flow unobstructed into the receptacle.

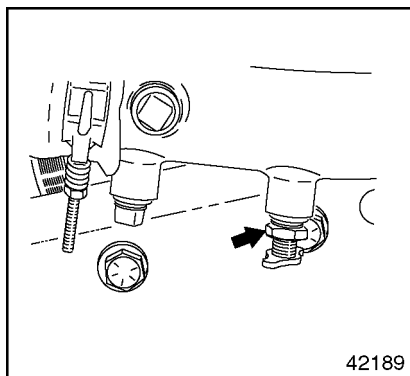

Figure 33 Coolant Drain Plug

NOTICE:

Do not apply more than 20 psi (140 kPa) air pressure for a radiator flush; more pressure could damage the radiator or heater core.

4. Start radiator flushing by attaching a flushing gun nozzle to the radiator outlet and run water in until the radiator is full.



WARNING:

EYE INJURY

To avoid injury from flying debris when using compressed air, wear adequate eye protection (face shield or safety goggles) and do not exceed 276 kPa (40 psi) air pressure.

5. Apply no more than 140 kPa (20 psi) air pressure intermittently to help dislodge sediment buildup in the core.
6. Drain the radiator, and flush the radiator until clean water flows from the radiator. Remove the flushing gun.
7. When the coolant has drained, install the coolant drain plug on the radiator.
8. Add coolant in the specified concentration until the maximum mark on the surge tank is reached.
9. Start the engine and run it for about one minute at varying speeds to release air pockets in the cooling system. Ensure the heater valve is still open. Check the coolant level and add more coolant if necessary.
10. Shut down the engine, close and tighten the cap on the surge tank.

Cooling System Inspecting

NOTE:

Before doing this inspection, do either "Coolant Concentration Checking," or "Coolant Flushing and Changing."

Inspect the cooling system as follows:



WARNING:

HOT COOLANT

To avoid scalding from the expulsion of hot coolant, never remove the cooling system pressure cap while the engine is at operating temperature. Wear adequate protective clothing (face shield, rubber gloves, apron, and boots). Remove the cap slowly to relieve pressure.

1. Inspect the radiator, condenser, coolant pump, engine oil cooler, freeze plugs, and heat exchanger for damage and leaks.
2. Check all cooling system pipes and hoses for damage and leaks; ensure they are positioned to avoid chafing, and are securely fastened.
3. Check the outside of the radiator and condenser for blockage. Check fins for damage; straighten them if necessary.

Rear Engine Power Take-Off (REPTO)

The REPTO accessory drive is an option on the MBE 4000 engine. The drive provides continuous live power anytime the engine is operating. The REPTO is driven by the camshaft gear and is an integral part of a unique SAE#1 flywheel housing. All REPTO installations require a torsional coupling installed at the flange of the drive unit (i.e. hydraulic pump). The torsional coupling incorporates a rubber element designed to reduce the unwanted stresses from reaching the engine. See Figure 34.

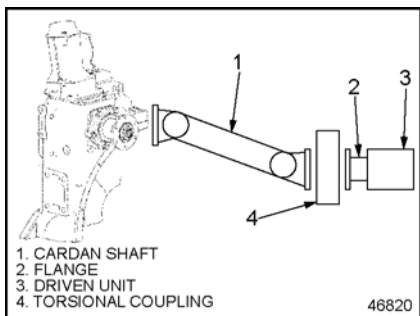

Figure 34 MBE 4000 REPTO Connection Illustration

REPTO Torsional Damper

Inspection — Inspect the REPTO torsional damper as follows:

1. Inspect the outer casing of the torsional damper for dents or bulges. If damage is found

replace the damper. Regardless of the condition, the torsional coupling must be replaced at normal engine overhaul.

2. Inspect the torsional damper rubber element as follows:
 - [a] Check the rubber element for bulges or cracks. If damage is found replace the damper.
 - [b] Inspect the rubber element teeth for wear. If the teeth are worn to less than one-half of the new part length (11.0 mm [0.433 in.]), replace the torsional damper. See Figure 35.

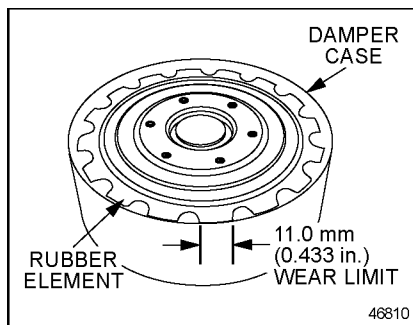

Figure 35 REPTO Torsional Damper

REPTO Torsional Damper Cleaning — Clean the REPTO torsional damper as follows:

The torsional damper coupling will withstand normal exposure to hydraulic oil, diesel fuel, anti-freeze solutions, and muriatic acid. The coupling should be washed with a mild soap solution and rinsed with water after contact with the above items. The coupling can be power washed without damage as long as it is installed in the vehicle. If the coupling is power washed when not connected to a cardan shaft, debris may be forced internally at the bolt flanges damaging the coupling.

CUSTOMER ASSISTANCE

The satisfaction and good will of the owners of Detroit Diesel engines are of primary concern to Detroit Diesel

Corporation and its distributor/dealer organizations.

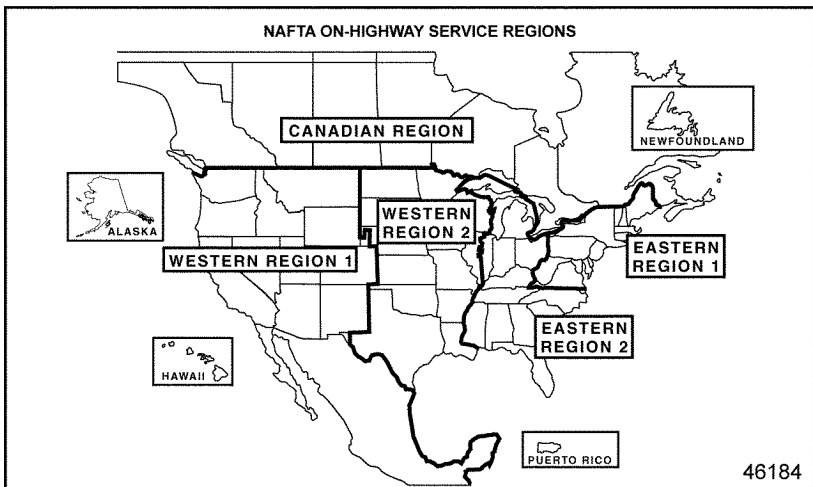
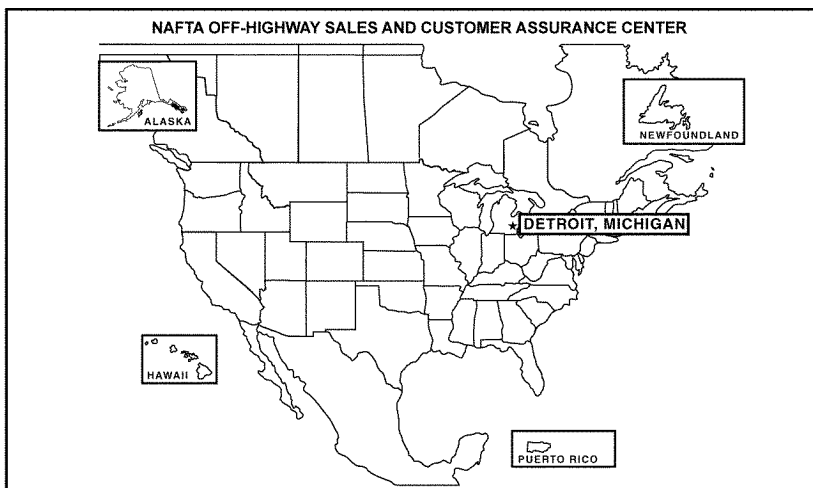

DDC NORTH AMERICAN NAFTA ON-HIGHWAY OFFICES

EASTERN REGION 1

Suwanee, Georgia

3325 Paddocks Parkway

Suwanee, GA 30024

Telephone: 678-341-6100

Fax: 678-341-6150

WESTERN REGION 1

Irvine, California

7700 Irvine Center, Suite 275

Irvine, CA 92618

Telephone: 949-753-7710

Fax: 949-753-7711

CANADIAN REGION

London, Ontario

Detroit Diesel of Canada, Ltd.

150 Dufferin Ave., Suite 701

London, ON N5A 5N6

Phone: 519-661-0149

Fax: 519-661-0171

EASTERN REGION 2

Detroit, Michigan

13400 Outer Drive West

Detroit, MI 48239-4001

Telephone: 313-592-5420

Fax: 313-592-5887

WESTERN REGION 2

Irvine, California

7700 Irvine Center, Suite 275

Irvine, CA 92618

Telephone: 949-753-7710

Fax: 949-753-7711

**MTU DETROIT DIESEL OFF-HIGHWAY SALES AND
CUSTOMER ASSURANCE CENTERS**

**CONSTRUCTION, INDUSTRIAL
AND MINING SALES (BX7)**

13400 Outer Drive, West
Detroit, MI 48239-4001
Phone: 313-592-5608
Fax: 313-592-5625

MARINE SALES (BX6)

13400 Outer Drive, West
Detroit, MI 48239-4001
Phone: 313-592-7806
Fax: 313-592-5137

**POWERGEN AND OIL FIELD SALES
(BX11)**

13400 Outer Drive, West
Detroit, MI 48239-4001
Phone: 313-592-5708
Fax: 313-592-5158

GOVERNMENT SALES (BX9)

13400 Outer Drive, West
Detroit, MI 48239-4001
Phone: 313-592-5875
Fax: 313-592-5158

CUSTOMER ASSURANCE (M24)

13400 Outer Drive, West
Detroit, MI 48239-4001
Phone: 313-592-5550
Fax: 313-592-5717

DDC INTERNATIONAL REGIONAL OFFICE LOCATIONS

**DETROIT DIESEL DISTRIBUTION
CENTER B.V.(On/Off-Highway)
The Netherlands**

Ridderpoort 9
2984 Ridderkerk
The Netherlands
Phone: (31) 180-442-900
Fax: (31) 180-462-062

**MTU DETROIT DIESEL AUSTRALIA
PTY. LTD.(On/Off-Highway)**

Victoria – Melbourne
488 Blackshaws Road
Altona North, Victoria 3205
Australia
Phone: (61) 3 9243-9292
Fax: (61) 3 9243-9271

MEXICO (On/Off-Highway)

Detroit Diesel Allison de Mexico, S.A.
Av. Santa Rosa 58
Col. Ampliacion Norte
54160 Tlalnepantla
Edo. de Mexico
MEXICO
Phone: 52 55-5333-1803
Fax: 52 55-5333-1875

**LATIN AMERICAN REGION
(Off-Highway)**

Miami, Florida
2277 N.W. 14th Street
Latin America Building
Miami, FL 33125-0068
Phone: 305-637-1555
Fax: 305-637-1580

**MTU ASIA PTE. LTD. (Off-Highway)
Singapore**

No. 1 Benoi Place
Singapore 629923
Phone: (65) 6861-5922
Fax: (65) 6861-3615 Sales Marine,
Rail, C & I, Electronics
Fax: (65) 6860-9959 Sales PowerGen,
Defense

Working with DDC Service Outlets

As the owner of a Detroit Diesel product you have a complete network of over 1,000 Detroit Diesel service outlets in the U.S. and Canada, plus many outlets worldwide that are prepared to meet your parts and service needs:

- Service by trained personnel
- Sales teams to help determine your specific power requirements
- In many areas, emergency service 24 hours a day
- Complete parts support including reliabilt® remanufactured parts
- Product information and literature

We recognize however, that despite the best intentions of everyone concerned, misunderstandings may occur. Normally, any situation that arises in connection with the sale, operation, or service of your product will be handled by the authorized service outlet in your area (in the U.S. and Canada check the Yellow Pages or service locator at www.detroitdiesel.com for the Detroit Diesel service outlet nearest you).

To further assure your complete satisfaction, we have developed the following procedure to use if you have a problem that has not been handled satisfactorily.

Step One

Discuss your problem with a member of management from the authorized service outlet. Frequently, complaints are the result of a breakdown in communication and can quickly be resolved by a member of management. If you have already discussed the problem with the Sales or Service Manager, contact the General Manager. If your complaint originates with a dealer, explain the matter to a management member of the distributorship with whom the dealer has his service agreement.

Step Two

When it appears that your problem cannot readily be resolved at the distributor level without additional assistance, contact the Detroit Diesel Regional Product Support or Operations Manager responsible for your local distributor. You will be assisted by a member of the Manager's staff, depending upon the nature of your problem.

Prior to this contact, have the following information available:

- Engine model and serial number
- Name and location of authorized service outlet
- Type and make of equipment

- Engine delivery date and accumulated miles or hours of operation
- Nature of problem
- Chronological summary of engine's history

Step Three

If you are still not satisfied, present the entire matter in writing or by phone to:

**Sr. Vice President, Parts, Service
and Customer Support**

Detroit Diesel Corporation
13400 Outer Drive, West
Detroit, Michigan 48239-4001
Phone: 313-592-5000
Fax: 313-592-7244

When contacting the regional or home office, please keep in mind that ultimately your problem will likely be resolved at the distributorship or dealership, utilizing their facilities, equipment, and personnel. Therefore, it is suggested that you follow the previously mentioned steps in sequence when experiencing a problem.

LIMITED WARRANTY ON NEW DETROIT DIESEL MBE 4000 ENGINES USED IN ON-HIGHWAY VEHICLE APPLICATIONS

Terms of Coverage

Uses

This warranty applies to the first retail purchaser and subsequent owners during the WARRANTY PERIOD of new Detroit Diesel MBE 4000 Engines (referred to as Engine) manufactured by Detroit Diesel Corporation and/or supplied by Detroit Diesel Corporation or Detroit Diesel of Canada Limited (which are collectively referred to as DDC) for use in on-highway vehicle applications operated in the United States or Canada.

Defects

This warranty covers Engine REPAIRS to correct any malfunction occurring during the WARRANTY PERIOD resulting from defects in material or workmanship.

Repairs

To obtain warranty repairs, you must request the needed repairs within the WARRANTY PERIOD from an authorized DDC service outlet. Only new genuine parts or remanufactured parts or components supplied or

approved by DDC will be used. DDC may, at its discretion, replace rather than repair components. A reasonable time must be allowed to perform the warranty repair after taking the engine to the authorized service outlet. The owner is responsible for the percentage of repair costs shown in the warranty period chart. Repairs will be performed during normal business hours.

Warranty Period

The WARRANTY PERIOD begins on the date the engine is delivered to the first retail purchaser or put in use prior to sale at retail, whichever date occurs first, and ends at the time or mileage/kilometer limits shown in the WARRANTY PERIOD chart.

*LIMITED WARRANTY ON NEW DETROIT DIESEL MBE 4000 ENGINES
USED IN ON-HIGHWAY VEHICLE APPLICATIONS*

| Warranty Period | | | | |
|--|--|------------------------------|---|--|
| Item | Warranty Limitations (Whichever Occurs First) | | Repair Charges to be Paid by Owner | |
| | Months | Miles/ Kilometers | Parts | Labor |
| Engine | 0-24 | Unlimited | No Charge | No Charge |
| Accessories | 0-24 | 0-100,000 mi 0-160,000 km | No Charge | No Charge |
| <i>Upon expiration of the 24 month warranty coverage, but within 500,000 mi/800,000 km of use, the warranty continues to apply as follows:</i> | | | | |
| Major Components* | 25-60 | 0-500,000 mi 0-800,000 km | No Charge | 100% of service outlet's normal charge |

* Cylinder Block/Head, Crankshaft, Camshaft, Main Bearing Bolts, Flywheel Housing, Connecting Rod Assemblies, Oil Cooler Housing, Water Pump Housing and Air Inlet Housing.

Table 25 Warranty Period Chart — On-highway Vehicle Applications

Like Replacement Engine

Engine(s) supplied by DDC as a replacement for an engine still under warranty will assume the identity of the engine being replaced and be entitled to the remaining warranty coverage.

Engine Removal and Reinstallation

Reasonable labor costs for engine removal and reinstallation, when necessary to make a warranty repair, are covered by this warranty.

Service Supplies

The cost of service supplies such as coolant, oil and filters which are not reusable due to needed warranty repairs is covered by this warranty.

This Warranty Does Not Cover:

Repairs Due to Accidents, Misuse, Storage Damage, Negligence or Certain Modifications

Repairs due to an accident, misuse, misapplication, storage damage, negligence or modification exceeding DDC specifications are not covered by this warranty.

Fuel Injection System After 100,000 Miles/160, 000 Kilometers

The repair or replacement of fuel injection pump, high pressure lines and nozzles after 100,000 miles/160,000 kilometers of operation is not covered by this warranty.

Maintenance

DDC is not responsible for the cost of maintenance or repairs due to lack of performance of required maintenance services as recommended by DDC, or the failure to use fuel, oil, lubricants and coolant meeting DDC-recommended specifications. Performance of the required maintenance and use of proper fuel, oil, lubricants and coolant are the responsibility of the owner. Refer to the Engine Operator's Guide for details.

Incidental or Consequential Damages

Detroit Diesel Corporation is not responsible for incidental or consequential costs or expenses which the owner may incur as a result of a malfunction or failure covered by this warranty, such as communication expenses, meals, lodging, loss of use of the engine or vehicle ("downtime"), loss of time, inconveniences, cargo loss or damage, and other similar costs and experiences.

Other Limitations

Performance of REPAIRS is the exclusive Owner's remedy under this warranty. Detroit Diesel Corporation does not authorize any person to assume or create for it any other obligation or liability in connection with the engine or the accessories.

*LIMITED WARRANTY ON NEW DETROIT DIESEL MBE 4000 ENGINES
USED IN ON-HIGHWAY VEHICLE APPLICATIONS*

THIS WARRANTY AND THE EMISSIONS CONTROL WARRANTY ARE THE ONLY WARRANTIES APPLICABLE TO THE ENGINE AS USED IN ON-HIGHWAY VEHICLE APPLICATIONS. DETROIT DIESEL CORPORATION MAKES NO OTHER WARRANTIES EXPRESS OR IMPLIED, INCLUDING ANY IMPLIED WARRANTY OF MERCHANTABILITY OR FITNESS FOR A PARTICULAR PURPOSE. DETROIT DIESEL CORPORATION SHALL NOT BE LIABLE FOR ANY INCIDENTAL OR CONSEQUENTIAL DAMAGES AS DESCRIBED ABOVE.

Some states do not allow the limitation of how long this warranty may last or the limitation or exclusion of incidental or consequential damages, so the above may not apply to you. This warranty gives you special legal rights, and you may also have other rights which may vary from state to state.

LIMITED WARRANTY ON NEW DETROIT DIESEL MBE 4000 ENGINES USED IN FIRE TRUCK OR CRASH VEHICLE APPLICATIONS

Terms of Coverage

Uses

This warranty applies to the first retail purchaser and subsequent owners during the WARRANTY PERIOD of new Detroit Diesel MBE 4000 Engines (referred to as Engine) manufactured by Detroit Diesel Corporation and/or supplied by Detroit Diesel Corporation or Detroit Diesel of Canada Limited (which are collectively referred to as DDC) for use in fire truck or crash vehicle applications operated in the United States or Canada.

Defects

This warranty covers Engine REPAIRS to correct any malfunction occurring during the WARRANTY PERIOD resulting from defects in material or workmanship.

Repairs

To obtain warranty repairs, you must request the needed repairs within the WARRANTY PERIOD from an authorized DDC service outlet. Only new genuine parts or remanufactured parts or components supplied or

approved by DDC will be used. DDC may, at its discretion, replace rather than repair components. A reasonable time must be allowed to perform the warranty repair after taking the engine to the authorized service outlet. The owner is responsible for the percentage of repair costs shown in the warranty period chart. Repairs will be performed during normal business hours.

Warranty Period

The WARRANTY PERIOD begins on the date the engine is delivered to the first retail purchaser or put in use prior to sale at retail, whichever date occurs first, and ends at the time or mileage/kilometer limits shown in the WARRANTY PERIOD chart.

*LIMITED WARRANTY ON NEW DETROIT DIESEL MBE 4000 ENGINES
USED IN FIRE TRUCK OR CRASH VEHICLE APPLICATIONS*

| Warranty Period | | | | |
|------------------------|--|------------------------------|---|--------------|
| Item | Warranty Limitations (Whichever Occurs First) | | Repair Charges to be Paid by Owner | |
| | Months | Miles/ Kilometers | Parts | Labor |
| Engine | 0-60 | 0-100,000 mi 0-160,000 km | No Charge | No Charge |
| Accessories | 0-24 | 0-100,000 mi 0-160,000 km | No Charge | No Charge |

Table 26 Warranty Period Chart — On-highway Vehicle Applications

Like Replacement Engine

Engine(s) supplied by DDC as a replacement for an engine still under warranty will assume the identity of the engine being replaced and be entitled to the remaining warranty coverage.

Service Supplies

The cost of service supplies such as coolant, oil and filters which are not reusable due to needed warranty repairs is covered by this warranty.

Engine Removal and Reinstallation

Reasonable labor costs for engine removal and reinstallation, when necessary to make a warranty repair, are covered by this warranty.

This Warranty Does Not Cover:

Repairs Due to Accidents, Misuse, Storage Damage, Negligence or Certain Modifications

Repairs due to an accident, misuse, misapplication, storage damage, negligence or modification exceeding DDC specifications are not covered by this warranty.

Fuel Injection System After 100,000 Miles/160, 000 Kilometers

The repair or replacement of fuel injection pump, high pressure lines and nozzles after 100,000 miles/160,000 kilometers of operation is not covered by this warranty.

Maintenance

DDC is not responsible for the cost of maintenance or repairs due to lack of performance of required maintenance services as recommended by DDC, or the failure to use fuel, oil, lubricants and coolant meeting DDC-recommended specifications. Performance of the required maintenance and use of proper fuel, oil, lubricants and coolant are the responsibility of the owner. Refer to the Engine Operator's Guide for details.

Incidental or Consequential Damages

Detroit Diesel Corporation is not responsible for incidental or consequential costs or expenses which the owner may incur as a result of a malfunction or failure covered by this warranty, such as communication expenses, meals, lodging, loss of use of the engine or vehicle ("downtime"), loss of time, inconveniences, cargo loss or damage, and other similar costs and experiences.

Other Limitations

Performance of REPAIRS is the exclusive Owner's remedy under this warranty. Detroit Diesel Corporation does not authorize any person to assume or create for it any other

obligation or liability in connection with the engine or the accessories.

THIS WARRANTY AND THE EMISSIONS CONTROL WARRANTY ARE THE ONLY WARRANTIES APPLICABLE TO THE ENGINE AS USED IN ON-HIGHWAY VEHICLE APPLICATIONS. DETROIT DIESEL CORPORATION MAKES NO OTHER WARRANTIES EXPRESS OR IMPLIED, INCLUDING ANY IMPLIED WARRANTY OF MERCHANTABILITY OR FITNESS FOR A PARTICULAR PURPOSE. DETROIT DIESEL CORPORATION SHALL NOT BE LIABLE FOR ANY INCIDENTAL OR CONSEQUENTIAL DAMAGES AS DESCRIBED ABOVE.

Some states do not allow the limitation of how long this warranty may last or the limitation or exclusion of incidental or consequential damages, so the above may not apply to you. This warranty gives you special legal rights, and you may also have other rights which may vary from state to state.