

ZEPHYR[®]
TOOL
GROUP



TOOLS ENGINEERED TO PERFORM

ZEPHYR[®]
SCREWDRIVING TOOLS

KWIK-LOK[™]
TEMPORARY FASTENERS

ZEPHYR[®]
AEROSPACE HAND & PNEUMATIC TOOLS

LOK-FAST[™]
AEROSPACE FASTENER TOOLS

Martin[™]
AIRCRAFT TOOL

Kwik-Lok[®] Temporary Fasteners



Distributor:

Edgar Hausmann GmbH, Förster-Busch-Str. 10, 34346 Hann. Münden, Germany

Tel: 0049 (0) 5545 91030 | www.hausmann.aero | info@hausmann.aero



PLIER-OPERATED TEMPORARY FASTENER

A diversity of plier actuated clamps for precise holding of materials

K The K-type sheet holder clamp is the standard KWIK-LOK® clamp. It is pliers-actuated, spring loaded and steel bodied; it is effective for most space requirements.



KK The KK-type sheet holder clamp is designed for those space requirements which prohibit the use of the standard K-type clamp. The KK-type is a miniature clamp, with a shorter overall body and special effectiveness for more confined areas.



K/KEL The KL and KEL-type clamps are standard K-type clamps with an extended grip range.



KHD The KHD clamp is designed specifically for heavier applications requiring an extended grip range not available in the standard K through KL series of sheet metal holders.



HOW TO SELECT A PART NUMBER

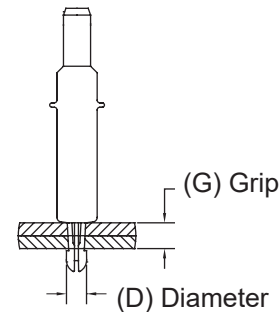
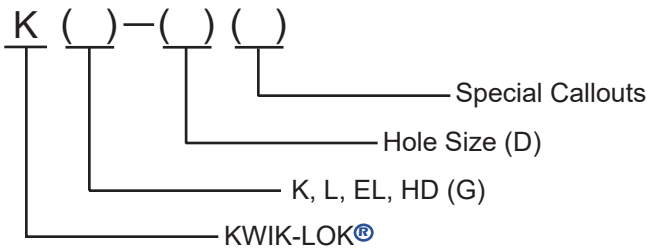

KT The KT is a variation of the standard K series. It has a pilot with which to index into holes through templates or outer material thicknesses.

HOW TO DETERMINE A TEMPLATE CLAMP PART NUMBER (K-KL SERIES)

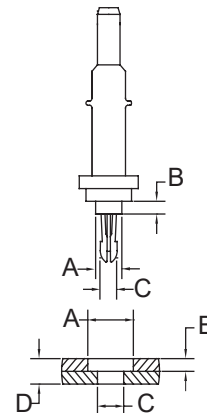
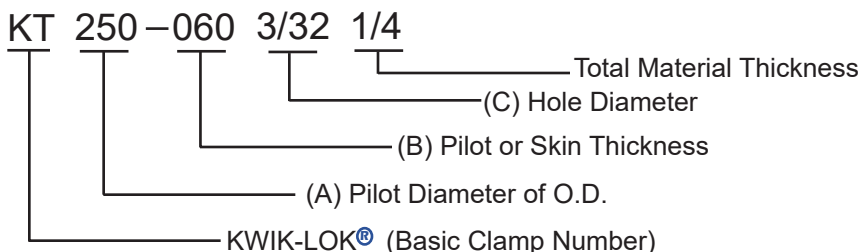

Distributor:

Edgar Hausmann GmbH, Förster-Busch-Str. 10, 34346 Hann. Münden, Germany
 Tel: 0049 (0) 5545 91030 | www.hausmann.aero | info@hausmann.aero



ORDERING INFORMATION PLIER OPERATED FASTENERS

PART NO.	CROSS REFERENCE EQUIVALENT	COLOR CODE	G (grip)	D (diameter)	DRILL SIZE
K-1/16	M-1/16	black	0 - 1/4"	1/16"	1/16"
K-3/32	M-3/32	zinc		3/32"	#40
K-1/8	M-1/8	copper		1/8"	#30
K-5/32	M-5/32	black		5/32"	#20
K-3/16	M-3/16	brass		3/16"	#10
K-7/32	M-7/32	zinc		7/32"	7/32"
K-1/4	M-1/4	copper		1/4"	1/4"
KK-3/32	MM-3/32	zinc	0 - 1/4"	3/32"	#40
KK-1/8	MM-1/8	copper		1/8"	#30
KK-5/32	MM-5/32	black		5/32"	#20
KK-3/16	MM-3/16	brass		3/16"	#10
KL-3/32	ML-3/32	zinc	1/4"-1/2"	3/32"	#40
KL-1/8	ML-1/8	copper		1/8"	#30
KL-5/32	ML-5/32	black		5/32"	#20
KL-3/16	ML-3/16	brass		3/16"	#10
KEL-3/32	MEL-3/32	zinc	1/2" - 3/4"	3/32"	#40
KEL-1/8	MEL-1/8	copper		1/8"	#30
KEL-5/32	MEL-5/32	black		5/32"	#20
KEL-3/16	MEL-3/16	brass		3/16"	#10
KHD-3/32	MHD-3/32	zinc	0 - 1/2"	3/32"	#40
KHD-1/8	MHD-1/8	copper		1/8"	#30
KHD-5/32	MHD-5/32	black		5/32"	#20
KHD-3/16	MHD-3/16	brass		3/16"	#10
KHD-7/32	MHD-7/32	zinc		7/32"	7/32"
KHD-1/4	MHD-1/4	copper		1/4"	1/4"

Special Callouts AL = Aluminum Body BO = Black Oxide

PLIERS

Zephyr Pliers

Part No. K-200

Specially designed for installing the K, KK, KT, KL, KEL, KHD, clamps and side grips (pg 6).

The KWIK-LOK Pliers are constructed of forged steel, with new ergonomic "soft-grip" handles, thus resisting wear and abuse.

KWIK-LOK Pliers are compatible with all spring-loaded-types of sheet metal clamps.

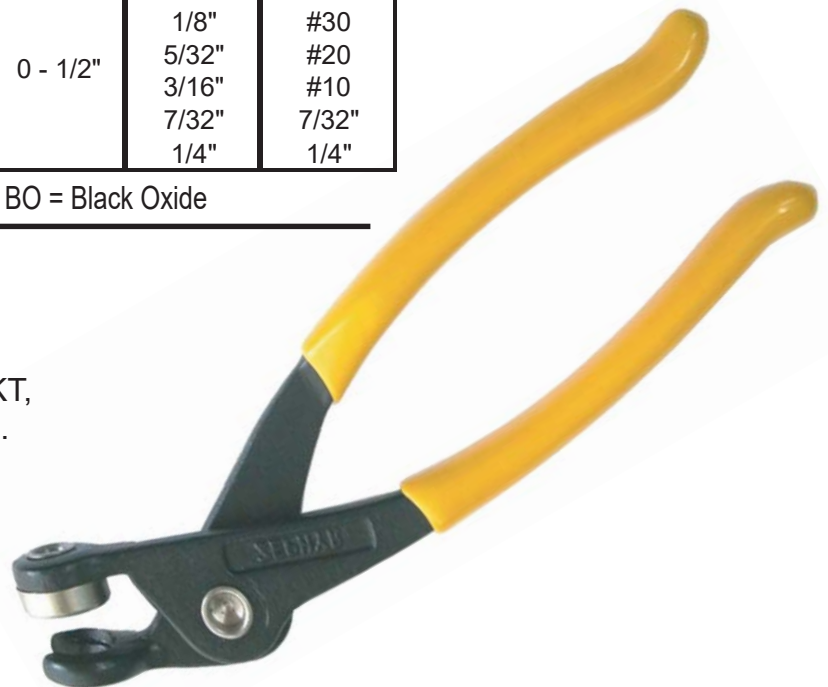



POWER-OPERATED & MANUAL TEMPORARY FASTENERS

FREE WHEELING

POWER - HEX NUT TYPE

KHNS
KHN
KHNL
KHNK



For high production applications that require a consistent, uniform clamping force. Pneumatic driven with the Power Nut Runner KNR2000 (pg 5), this time-saving fastener is well suited for both metallic and composite materials.

MANUAL - WING NUT TYPE

KWNS
KWN
KWNL
KWNK



For low production rates and high-clamping force applications. Because this fastener is manually controlled, the clamping force can range from zero to 300 lbs. Well-suited for all types of metallic and composite materials.

HOW TO SELECT PART NUMBER

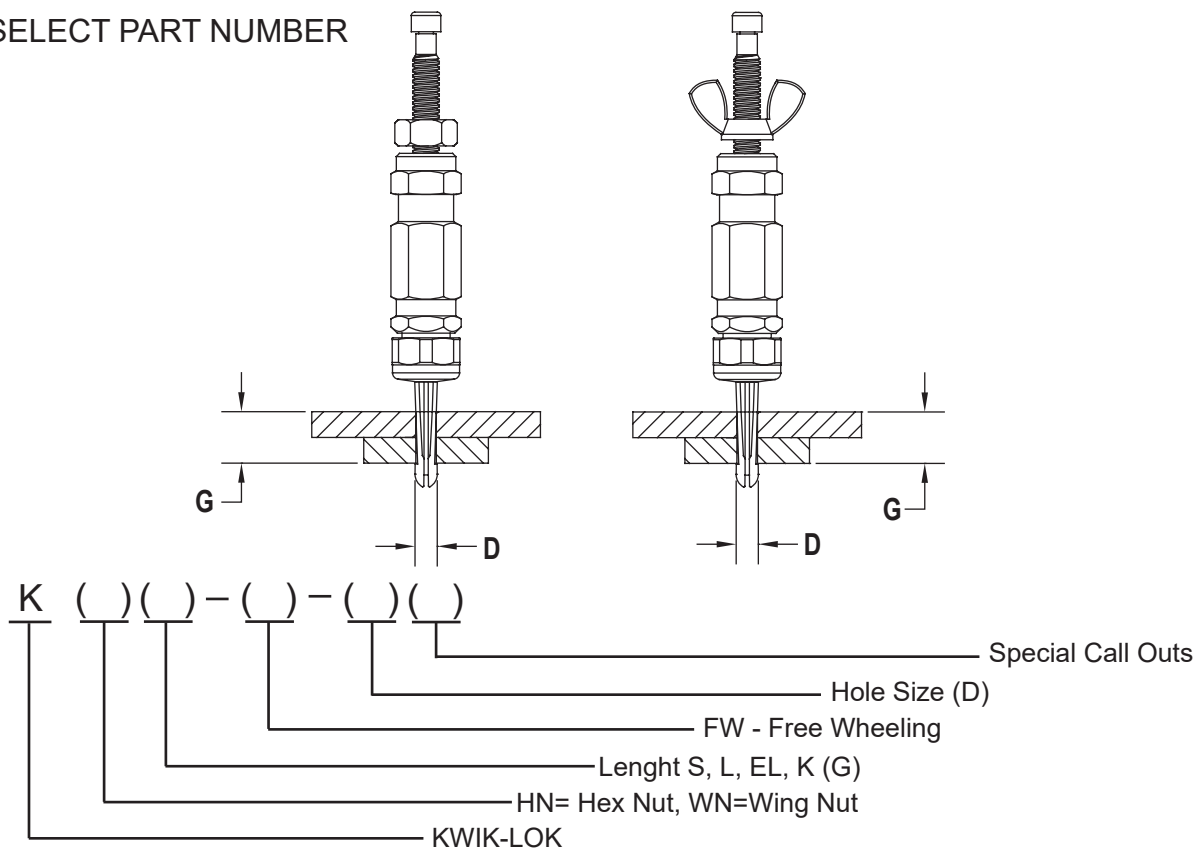

Distributor:

Edgar Hausmann GmH, Förster-Busch-Str. 10, 34346 Hann. Münden, Germany

Tel: 0049 (0) 5545 91030 | www.hausmann.aero | info@hausmann.aero



**POWER-OPERATED
TEMPORARY FASTENERS**

ORDERING INFORMATION

HEX NUT PART NO.	CROSS REFERENCE EQUIVALENT	COLOR CODE	G (grip)	D (diameter)	DRILL SIZE
KHNS-FW-3/32	HNXS-SF-3/32	silver	0-5/16"	3/32"	#40
KHNS-FW-1/8	HNXS-SF-1/8	copper		1/8"	#30
KHNS-FW-5/32	HNXS-SF-5/32	black		5/32"	#20
KHNS-FW-3/16	HNXS-SF-3/16	brass		3/16"	#10
KHNS-FW-1/4	HNXS-SH/4	copper		1/4"	1/4"
KHN-FW-3/32	HNX-SF-3/32	silver	0- 1/2"	3/32"	#40
KHN-FW-1/8	HNX-SF-1/8	copper		1/8"	#30
KHN-FW-5/32	HNX-SF-5/32	black		5/32"	#20
KHN-FW-3/16	HNX-SF-3/16	brass		3/16"	#10
KHN-FW-7/32	HNX-SF-7/32	silver		7/32"	7/32"
KHN-FW-1/4	HNX-SF-1/4	copper		1/4"	1/4"
KHN-FW-5/16	HNX-SF-5/16	black		5/16"	5/16"
KHNL-FW-3/32	HNXL-SF-3/32	silver	0-1"	3/32"	#40
KHNL-FW-1/8	HNXL-SF-1/8	copper		1/8"	#30
KHNL-FW-5/32	HNXL-SF-5/32	black		5/32"	#20
KHNL-FW-3/16	HNXL-SF-3/16	brass		3/16"	#10
KHNL-FW-7/32	HNXL-SF-7/32	silver		7/32"	7/32"
KHNL-FW-1/4	HNXL-SF-1/4	copper		1/4"	1/4"
KHNL-FW-5/16	HNXL-SF-5/16	black		5/16"	5/16"
KHNEL-FW-3/32	HNXEL-SF-3/32	silver	1/2" -1 1/2"	3/32"	#40
KHNEL-FW-1/8	HNXEL-SF-1/8	copper		1/8"	#30
KHNEL-FW-5/32	HNXEL-SF-5/32	black		5/32"	#20
KHNEL-FW-3/16	HNXEL-SF-3/16	brass		3/16"	#10
KHNEL-FW-1/4	HNXEL-SF-1/4	copper		1/4"	1/4"
KHNEL-FW-5/16	HNXEL-SF-5/16	black		5/16"	5/16"
KHNK-FW-1/8	HNXK-SH-1/8	copper	1 1/2" - 2 1/2"	1/8"	#30
KHNK-FW-5/32	HNXK-SF-5/32	black		5/32"	#20
KHNK-FW-3/16	HNXK-SF-3/16	brass		3/16"	#10
KHNK-FW-1/4	HNXK-SH-1/4	copper		1/4"	1/4"
KHNK-FW-5/16	HNXK-SF-5/16	black		5/16"	5/16"

Special Callouts AL= Aluminum Body BO = Black Oxide AC = Aluminum Cap C = Plastic Cap



MANUAL-OPERATED TEMPORARY FASTENERS

ORDERING INFORMATION

WING NUT PART NO.	CROSS REFERENCE EQUIVALENT	COLOR CODE	G (grip)	D (diameter)	DRILL SIZE
KWNS-FW-3/32	WNXS-3/32	silver	0-5/16"	3/32"	#40
KWNS-FW-1/8	WNXS-1/8	copper		1/8"	#30
KWNS-FW-5/32	WNXS-5/32	black		5/32"	#20
KWNS-FW-3/16	WNXS-3/16	brass		3/16"	#10
KWNS-FW-1/4	WNXS-1/4	copper		1/4"	1/4"
KWN-FW-3/32	WNX-3/32	silver	0- 1/2"	3/32"	#40
KWN-FW-1/8	WNX-1/8	copper		1/8"	#30
KWN-FW-5/32	WNX-5/32	black		5/32"	#20
KWN-FW-3/16	WNX-3/16	brass		3/16"	#10
KWN-FW-7/32	WNX-7/32	silver		7/32"	7/32"
KWN-FW-1/4	WNX-1/4	copper		1/4"	1/4"
KWN-FW-5/16	WNX-5/16	black		5/16"	5/16"
KWNL-FW-3/32	WNXL-3/32	silver	0-1"	3/32"	#40
KWNL-FW-1/8	WNXL-1/8	copper		1/8"	#30
KWNL-FW-5/32	WNXL-5/32	black		5/32"	#20
KWNL-FW-3/16	WNXL-3/16	brass		3/16"	#10
KWNL-FW-7/32	WNXL-7/32	silver		7/32"	7/32"
KWNL-FW-1/4	WNXL-1/4	copper		1/4"	1/4"
KWNL-FW-5/16	WNXL-5/16	black		5/16"	5/16"
KWNEL-FW-3/32	WNXEL-3/32	silver	1/2" - 1 1/2"	3/32"	#40
KWNEL-FW-1/8	WNXEL-1/8	copper		1/8"	#30
KWNEL-FW-5/32	WNXEL-5/32	black		5/32"	#20
KWNEL-FW-3/16	WNXEL-3/16	brass		3/16"	#10
KWNEL-FW-1/4	WNXEL-1/4	copper		1/4"	1/4"
KWNEL-FW-5/16	WNXEL-5/16	black		5/16"	5/16"
KWNK-FW-1/8	WNXK-1/8	copper	1 1/2" - 2 1/2"	1/8"	#30
KWNK-FW-5/32	WNXK-5/32	black		5/32"	#20
KWNK-FW-3/16	WNXK-3/16	brass		3/16"	#10
KWNK-FW-1/4	WNXK-1/4	copper		1/4"	1/4"
KWNK-FW-5/16	WNXK-5/16	black		5/16"	5/16"

Special Callouts AL= Aluminum Body BO = Black Oxide AC = Aluminum Cap C = Plastic Cap



POWER NUT RUNNER For use with all KHN's series Fasteners



KNR2000

A simple to operate, rugged power tool for installation and removal of all power operated fasteners. Quiet precise and made in the U.S.A.

- Heavy duty, yet light weight
- Simple to insert and remove hex nut fasteners
- Small nose piece allows easy accessibility where fasteners are close together
- Reversible motor with finger tip control for switching to reverse
- Greater torque in reverse for those difficult removals

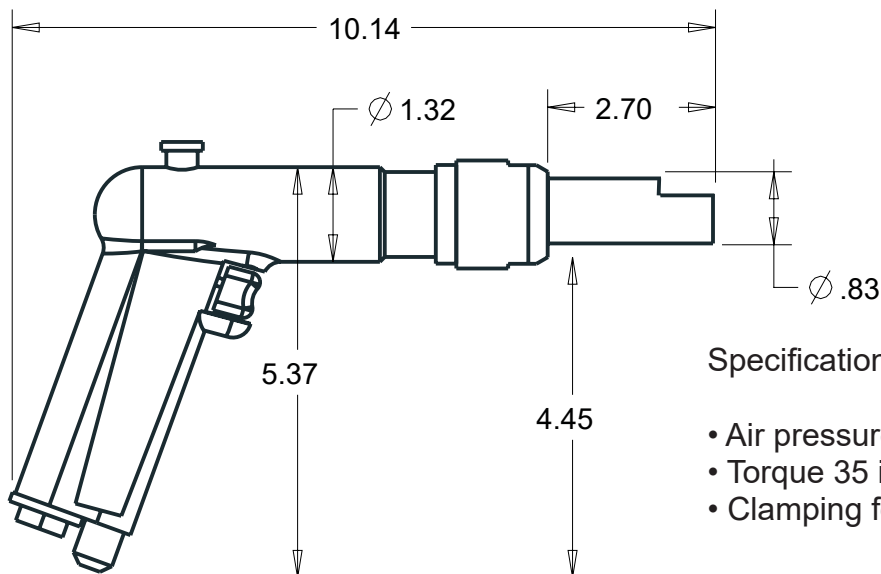

Specifications:

- Air pressure 85 -100 PSI
- Torque 35 in. lbs. max.
- Clamping force up to 360 lbs.

Distributor:

Edgar Hausmann GmbH, Förster-Busch-Str. 10, 34346 Hann. Münden, Germany

Tel: 0049 (0) 5545 91030 | www.hausmann.aero | info@hausmann.aero



DRILL STOP & CLAMP

KDS DRILL STOP

KWIK-LOK® manufactures a unique multipurpose tool designed to reduce drill bit breakage. These drill stops have a coiled spring to cushion the drill break-through.

Rounded smooth face eliminates marking and prevents the chuck jaws from marring the surface.



DRILL STOP ORDERING INFORMATION

PART NO	EQUIVALENT	COLOR CODE	DRILL SIZE
KDS 50	DS 50	black	#50
KDS 40	DS 40	zinc	#40
KDS 30	DS 30	copper	#30
KDS 28	DS 28	zinc	#28
KDS 21	DS 21	black	#21
KDS 20	DS 20	zinc	#20
KDS 12	DS 12	brass	#10
KDS 10	DS 10	brass	#10
KDS 1/4	DS 1/4	copper	1/4"
KDS 5/16	DS 5/16	copper	5/16"

NOTE: Other sizes available on request.



HANDI-KLAMPS

Zephyr Handi-Klamps are a versatile tool for clamping a wide range of surfaces, shapes, thicknesses and materials. Handi-Klamps are ideal for holding the

PART NO.	EQUIVALENT	CLAMPING CAPACITY	JAW DEPTH
K-1	W-1	0 - 5/16"	1"
K-2	W-2	0 - 5/16"	1 - 1/2"

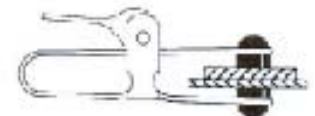



SIDE GRIP & TEMPORARY FASTENERS KITS

KSG SIDE GRIPS

Pliers operated edge klamps hold materials together where no holes are provided. Ideal for bonding, gluing and sealants.

SIDE GRIP ORDERING INFORMATION

PART NO.	EQUIVALENT	COLOR CODE	MATERIAL THICKNESS
KSG 1/2" x 1/2"	SG 1/2" x 1/2"	Copper	0 - 1/2"
KSG 3/4"x 1/2"	SG 3/4" x 1/2"	Brass	0 - 3/4"
KSG 1/2"x 1"	SG 1/2" x 1"	Copper	0 - 1/2"
KSG 3/4"x 1"	SG 3/4" x 1"	Brass	0 - 3/4"

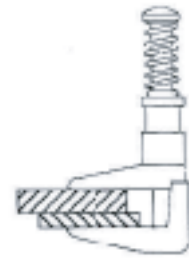
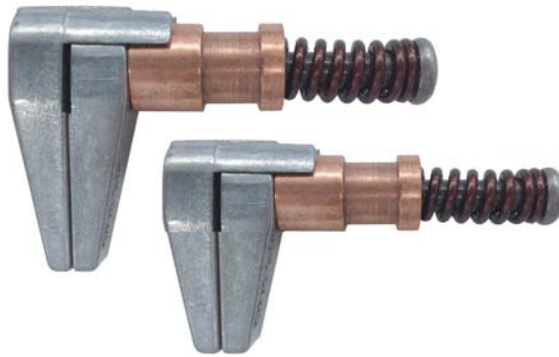

Temporary Fasteners kits

Zephyr offers a selection of Kwik-Lok temporary fasteners in convenient kit form. Each kit consists of Zephyr temporary fasteners, K-200 pliers, and carrying case.



ZKLS-1

Includes Pliers, two 1/2"x1" edge grip clamps, one each of hole clamps in sizes 3/32", 1/8", 3/16", 1/4".



ZKLS-2

Includes Pliers, ten of hole clamps in sizes 3/32", 1/8", 5/32", 3/16", 1/4".



ZKLS-3

Includes Pliers, six each of side clamps in sizes 1/2"x1", and 3/4"x1".

Distributor:

Edgar Hausmann GmbH, Förster-Busch-Str. 10, 34346 Hann. Münden, Germany
Tel: 0049 (0) 5545 91030 | www.hausmann.aero | info@hausmann.aero



KBN Bar Nut

Manually Operated Temporary Fastener

Part No.	Cross Ref. Equivalent	Color Code	G(grip)	D(diel.)	Drill Size
KBNS-FW-3/32	BNXS- 3/32	silver	0-5/16"	3/32"	#40
KBNS-FW-1/8	BNXS- 1/8	copper		1/8"	#30
KBNS-FW- 5/32	BNXS- 5/32	black		5/32"	#20
KBNS-FW- 3/16	BNXS- 3/16	brass		3/16"	#10
KBNS-FW-1/4	BNXS- 1/4	copper		1/4"	1/4"
KBN-FW- 3/32	BNX- 3/32	silver	0-1/2"	3/32"	#40
KBN-FW- 1/8	BNX- 1/8	copper		1/8"	#30
KBN-FW- 5/32	BNX- 5/32	black		5/32"	#20
KBN-FW- 3/16	BNX-3/16	brass		3/16"	#10
KBN-FW- 7/32	BNX- 7/32	silver		7/32"	7/32"
KBN-FW- 1/4	BNX- 1/4	copper		1/4"	1/4"
KBN-FW- 5/16	BNX- 5/16	black	5/16"	5/16"	
KBNL-FW- 3/32	BNXL- 3/32	silver	0-1"	3/32"	#40
KBNL-FW- 1/8	BNXL- 1/8	copper		1/8"	#30
KBNL-FW- 5/32	BNXL- 5/32	black		5/32"	#20
KBNL-FW- 3/16	BNXL- 3/16	brass		3/16"	#10
KBNL-FW- 7/32	BNXL- 7/32	silver		7/32"	7/32"
KBNL-FW- 1/4	BNXL- 1/4	copper		1/4"	1/4"
KBNL-FW- 5/16	BNXL- 5/16	black	5/16"	5/16"	
KBNEL-FW- 3/32	BNXEL- 3132	silver	1/2- 1 1/2"	3/32"	#40
KBNEL-FW- 1/8	BNXEL- 1/8	copper		1/8"	#30
KBNEL-FW- 5/32	BNXEL- 5/32	black		5/32"	#20
KBNEL-FW- 3/16	BNXEL- 3/16	brass		3/16"	#10
KBNEL-FW- 1/4	BNXEL- 1/4	copper		1/4"	1/4"
KBNEL-FW- 5/16	BNXEL- 5/16	black	5/16"	5/16"	
KBNK-FW-1/8	BNXK- 1/8	copper	1 1/2-21/2"	1/8"	#30
KBNK-FVI/-5/32	BNXK- 5/32	black		5/32"	#20
KBNK-FW-3/16	BNXK- 3/16	brass		3/16"	#10
KBNK-FW-1/4	BNXK- 1/4	copper		1/4"	1/4"
KBNK-FW-5/16	BNXK- 5/16	black		5/16"	5/16"

This temporary fastener is designed for low production and high clamping force applications.

The bar nut design enables the operator to apply the greatest amount of clamping force in a manual operation.

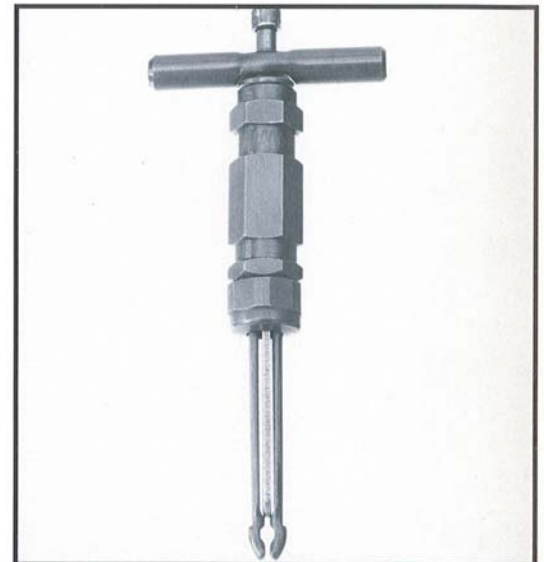

Special Callouts AL= Aluminum Body BO =Black Oxide AC =Aluminum Cap C=Plastic Cap

Distributor:

Edgar Hausmann GmbH, Förster-Busch-Str. 10, 34346 Hann. Münden, Germany

Tel: 0049 (0) 5545 91030 | www.hausmann.aero | info@hausmann.aero



Kwik-Lok®
Temporary Fastener

**PROTECTIVE CAPS FOR
Pliers Operated Fasteners**

K, KL, KEL

PART No.	NOMINAL SIZE	COLOR
KN23-3/32F	3/32	GRAY
KN23-1/8F	1/8	ORANGE
KN23-5/32F	5/32	BLACK
KN23-3/16F	3/16	BLUE
KN24-7/32F	7/32	GREEN
KN24-1/4F	1/4	YELLOW

KHD, KK

PART No.	NOMINAL SIZE	COLOR
KN24-3/32F	3/32	GRAY
KN24-1/8F	1/8	ORANGE
KN24-5/32F	5/32	BLACK
KN24-3/16F	3/16	BLUE
KN24-7/32F	7/32	GREEN
KN24-1/4F	1/4	YELLOW

**PROTECTIVE CAPS FOR
Power Operated & Manual Temporary
Fasteners**

**POWER-HEX NUT TYPE
KHNS, KHN, KHNL, KHNL, KHNK**

**MANUAL-HEX NUT TYPE
KWNS, KWN KWNL, KWNL, KWNK**

PART No.	NOMINAL SIZE	COLOR
KN25-4F	3/32	GRAY
KN25-2F	1/8	ORANGE
KN25-5F	5/32	BLACK
KN25-1F	3/16	BLUE
KN25-7F	7/32	GREEN
KN25-3F	1/4	YELLOW
KN25-6F	5/16	RED



**POWER-OPERATED
CYLINDRICAL BODY
TEMPORARY FASTENERS**

ORDERING INFORMATION

HOW TO SELECT PART NUMBER

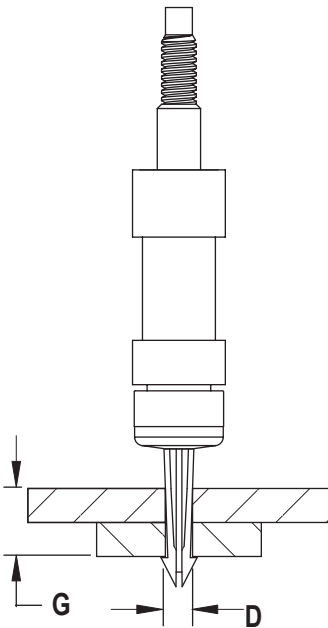
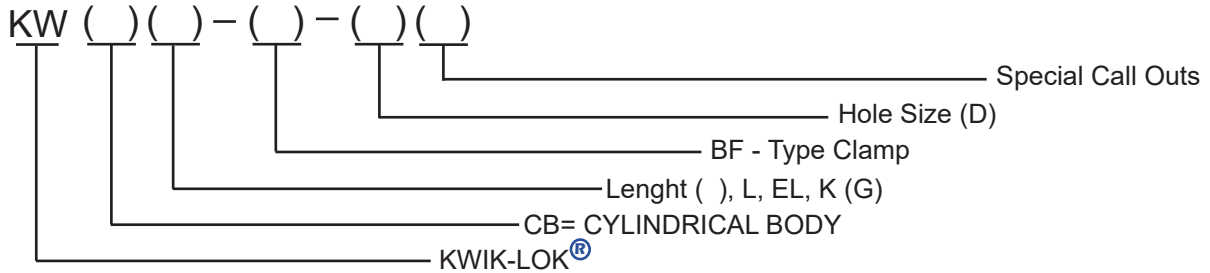

CYLINDRICAL BODY PART NO.	CROSS REFERENCE EQUIVALENT	COLOR CODE	G (grip)	D (diameter)	DRILL SIZE
KWCB-BF-3/32	CBX-BF-3/32	silver	0- 1/2"	3/32"	#40
KWCB-BF-1/8	CBX-BF-1/8	copper		1/8"	#30
KWCB-BF-5/32	CBX-BF-5/32	black		5/32"	#20
KWCB-BF-3/16	CBX-BF-3/16	brass		3/16"	#10
KWCB-BF-7/32	CBX-BF-7/32	silver		7/32"	7/32"
KWCB-BF-1/4	CBX-BF-1/4	copper		1/4"	1/4"
KWCB-BF-5/16	CBX-BF-5/16	black	0-1"	5/16"	5/16"
KWCBL-BF-3/32	CBXL-BF-3/32	silver		3/32"	#40
KWCBL-BF-1/8	CBXL-BF-1/8	copper		1/8"	#30
KWCBL-BF-5/32	CBXL-BF-5/32	black		5/32"	#20
KWCBL-BF-3/16	CBXL-BF-3/16	brass		3/16"	#10
KWCBL-BF-7/32	CBXL-BF-7/32	silver		7/32"	7/32"
KWCBL-BF-1/4	CBXL-BF-1/4	copper	1/2" - 1 1/2"	1/4"	1/4"
KWCBL-BF-5/16	CBXL-BF-5/16	black		5/16"	5/16"
KWCBEL-BF-3/32	CBXEL-BF-3/32	silver		3/32"	#40
KWCBEL-BF-1/8	CBXEL-BF-1/8	copper		1/8"	#30
KWCBEL-BF-5/32	CBXEL-BF-5/32	black		5/32"	#20
KWCBEL-BF-3/16	CBXEL-BF-3/16	brass		3/16"	#10
KWCBEL-BF-1/4	CBXEL-BF-1/4	copper	1 1/2" - 2 1/2"	1/4"	1/4"
KWCBEL-BF-5/16	CBXEL-BF-5/16	black		5/16"	5/16"
KWCBK-BF-1/8	CBXK-BF-1/8	copper		1/8"	#30
KWCBK-BF-5/32	CBXK-BF-5/32	black		5/32"	#20
KWCBK-BF-3/16	CBXK-BF-3/16	brass		3/16"	#10
KWCBK-BF-1/4	CBXK-BF-1/4	copper		1/4"	1/4"
KWCBK-BF-5/16	CBXK-BF-5/16	black	5/16"	5/16"	

Special Callouts AL= Aluminum Body BO = Black Oxide AC = Aluminum Cap C = Plastic Cap

Distributor:

Edgar Hausmann GmbH, Förster-Busch-Str. 10, 34346 Hann. Münden, Germany

Tel: 0049 (0) 5545 91030 | www.hausmann.aero | info@hausmann.aero



CYLINDRICAL BODY FASTENER INSTALLATION AND REMOVAL TOOL

KCB2000

A simple to operate, rugged power tool for installation and removal of all cylindrical body fasteners. Made in the U.S.A.



- Automatic Orientation - Tool onto fastener
 - Heavy duty, yet light weight
- Simple to insert and remove cylindrical body fasteners
- Reversible motor with finger tip control for switching to reverse
 - Greater torque in reverse for those difficult removals
 - Air pressure 85 - 100 PSI
 - Torque 35 in. lbs. max.
- Clamping force up to 360 lbs.

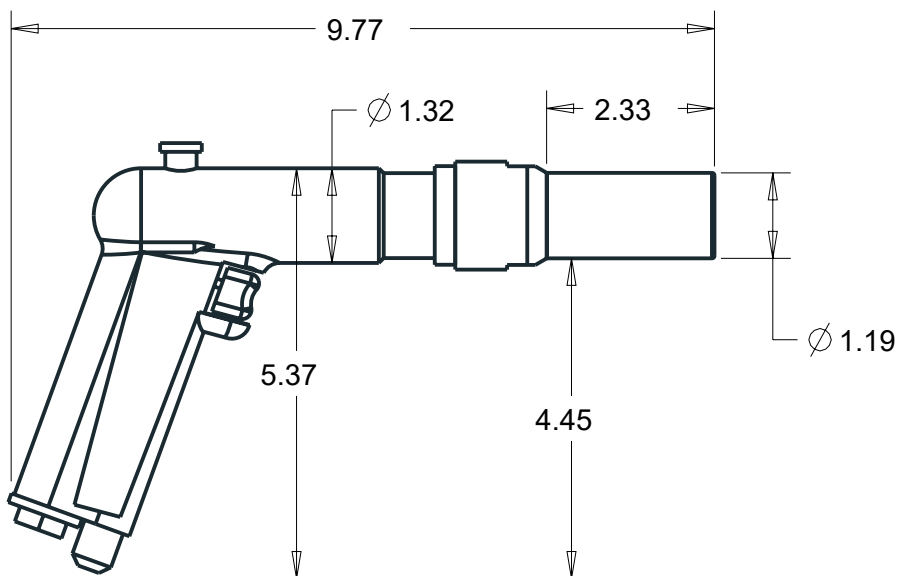

Standard Color - Blue
(shown above and below)



FOD Colors Available,
(Green Shown below)



* Other colors available upon request
(MOQ or upcharge apply)

Distributor:

Edgar Hausmann GmbH, Förster-Busch-Str. 10, 34346 Hann. Münden, Germany

Tel: 0049 (0) 5545 91030 | www.hausmann.aero | info@hausmann.aero



CYLINDRICAL BODY FASTENER INSTALLATION AND REMOVAL TOOL

KCB2000-MK

NEW

A simple to operate, rugged power tool for installation and removal of all cylindrical body fasteners.



- Automatic Orientation - Tool onto fastener
- Heavy duty, yet light weight
- Simple to insert and remove cylindrical body fasteners
- Reversible motor with finger tip control for switching to reverse
- Greater torque in reverse for those difficult removals
- Torque 35 in. lbs. max.(Adjustable)
- Clamping force varies.

Available Torque (in-lbs)	RPM
9-35	950



Super Kwik-Lok [®]
TEMPORARY FASTENERS

DIFFERENT STYLES TO ACCOMODATE YOUR FASTENING NEEDS



KSK Style
Basic fastener

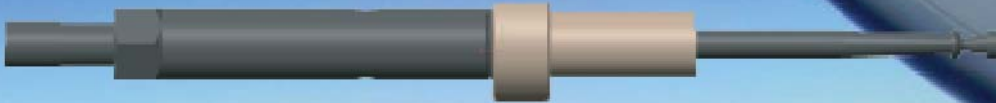

KSKC Style
Customizable
bushing available



KSKF Style
For use on
countersink holes



KSKJ Style
For jig fixtures



Torque Clamping Chart

How to select the proper fastener for your application

1. KSK Super Kwik-Lok (For style: KSK, KSKC, KSKF, KSKJ):

KSK Hole Callout	Nominal Size	Torque in-lbs	Maximum Clamp Load
187	3/16" (.1875)	36	750
250	1/4" (.250)	54	1125
312	5/16" (.3125)	87	1800
375	3/8" (.375)	97	2000
437	7/16" (.4375)	109	2250

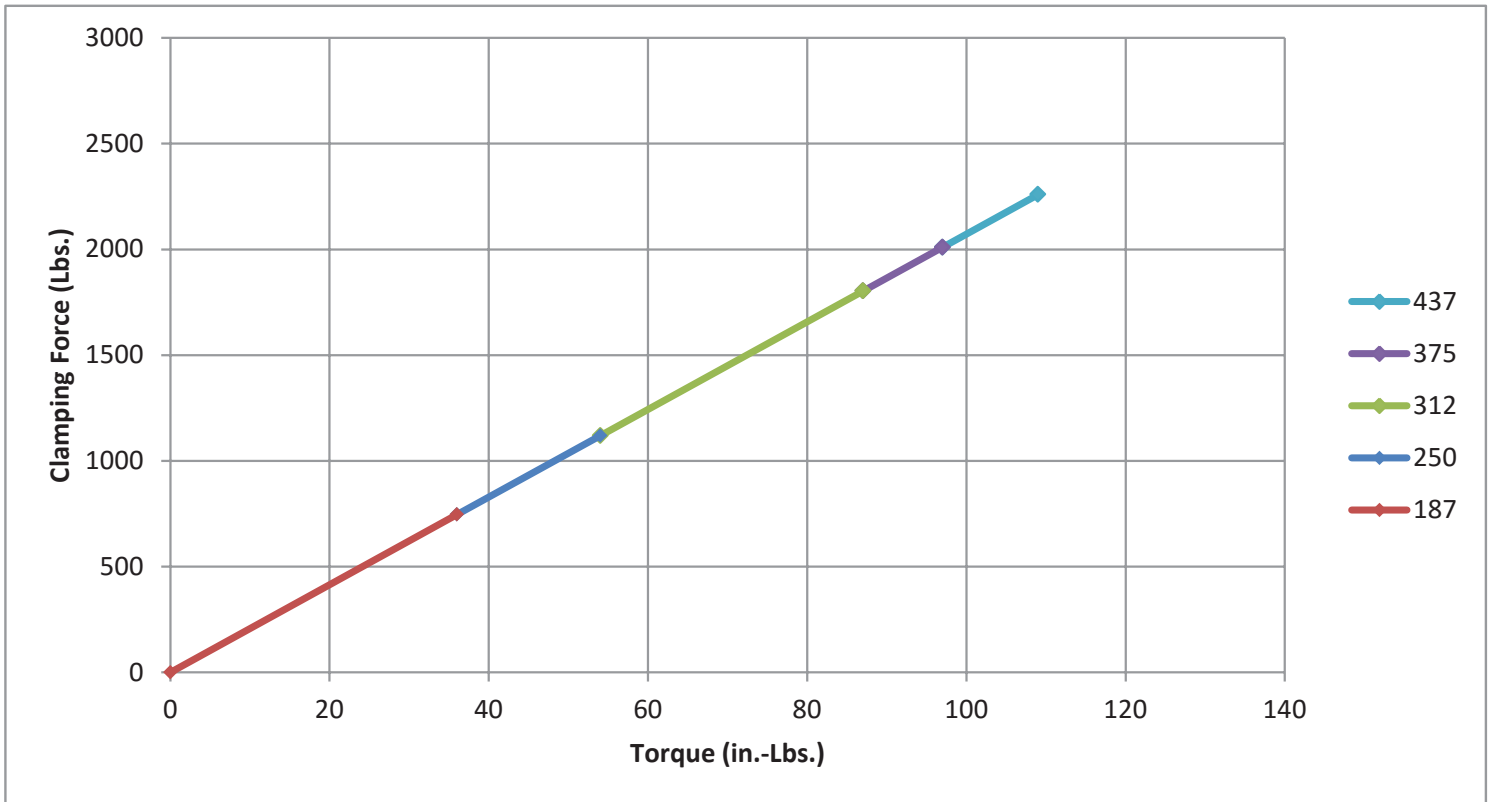

* Exceeding the listed values will run the risk of damaging clamping components and/or KSK product and is not recommended.



Super Kwik-Lok® TEMPORARY FASTENERS

ORDERING INFORMATION FOR KSK STYLE



HOW TO SELECT PART NUMBER:

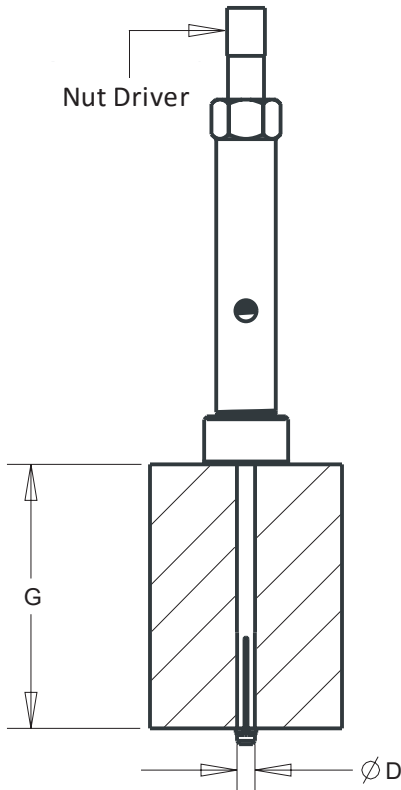
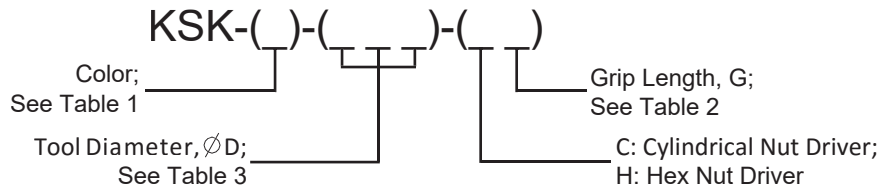

Example:
KSK-A-187-C4

.187" tool Diameter,
Cylindrical Nut,
1.50-2.50" grip length,
Aluminum Bushing.

Table 1: Color	
A	Aluminum
K	Black
B	Blue
C	Copper
G	Green
O	Orange
R	Red
S	Silver/Gray
W	White
Y	Yellow

Table 2: Grip Length, G	
1	0.00 – 1.00
2	0.50 – 1.50
3	1.00 – 2.00
4	1.50 – 2.50
5	2.00 – 3.00
6	2.50 – 3.50
7	3.00 – 4.00
8	3.50 – 4.50
9	4.00 – 5.00

Table 3: Hole Diameter, ØD	
187	.1875
250	.2500
312	.3125
375	.3750
437	.4375
500	.5000

Notes:

1. Actual tool diameter is manufactured 0.003 to 0.005 less than Hole call out.
2. Standard color is aluminum.

Distributor:

Edgar Hausmann GmbH, Förster-Busch-Str. 10, 34346 Hann. Münden, Germany
Tel: 0049 (0) 5545 91030 | www.hausmann.aero | info@hausmann.aero



Super Kwik-Lok®
TEMPORARY FASTENERS

ORDERING INFORMATION



KSKC Style
Customizable
bushing available

HOW TO SELECT PART NUMBER:

Example:

KSKC-C-250-C6-BBB

.250" tool Diameter,
Cylindrical Nut,
2.50-3.50" grip length,
Copper Bushing, with $\phi 1.00 \times \phi .562 \times 1.280$.

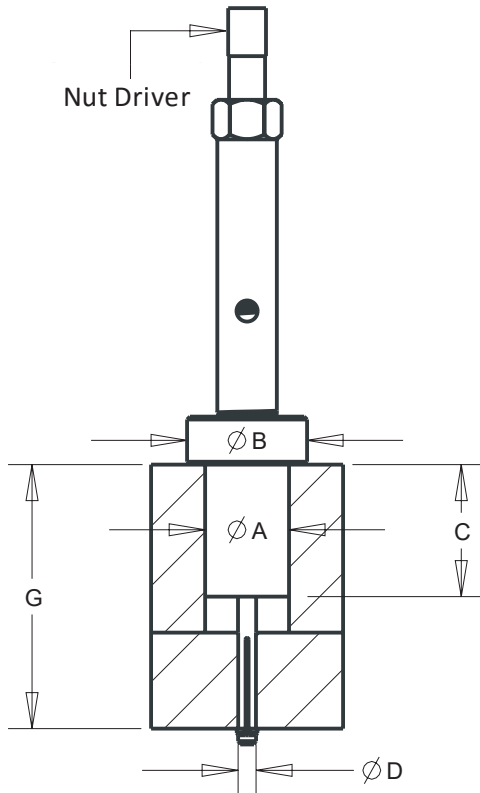
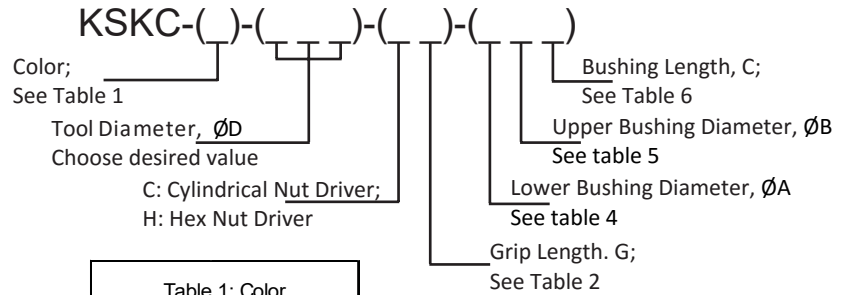

Table 1: Color

A	Aluminum
K	Black
B	Blue
C	Copper
G	Green
O	Orange
R	Red
S	Silver/Gray
W	White
Y	Yellow

Table 2: Grip Length, G

1	0.00 – 1.00
2	0.50 – 1.50
3	1.00 – 2.00
4	1.50 – 2.50
5	2.00 – 3.00
6	2.50 – 3.50
7	3.00 – 4.00
8	3.50 – 4.50
9	4.00 – 5.00

Table 3: Hole Diameter, ϕD

187	.1875
250	.2500
312	.3125
375	.3750
437	.4375
500	.5000

Table 4: Lower Bushing Diameter, ϕA

A	.500
B	.562
C	.610
D	.750
E	.874
F	.438
G	.625
H	.312
I	.813
J	1.124
K	1.250
L	1.000

Table 5: Upper Bushing Diameter, ϕB

A	0.87
B	1.00
C	1.20
D	1.25
E	1.06
F	1.38
G	1.67
H	1.42
I	1.50
J	1.75

Table 6: Bushing Length, C

A	0.67
B	1.28
C	1.38
D	1.50
E	3.00
F	1.18
G	1.46
H	1.75
I	1.00
J	0.75

Notes:

1. Actual tool diameter is manufactured 0.003 to 0.005 less than Hole call out.
2. Standard color is black.

Distributor:

Edgar Hausmann GmbH, Förster-Busch-Str. 10, 34346 Hann. Münden, Germany
Tel: 0049 (0) 5545 91030 | www.hausmann.aero | info@hausmann.aero



Super Kwik-Lok® TEMPORARY FASTENERS

ORDERING INFORMATION FOR KSKF STYLE



HOW TO SELECT PART NUMBER:

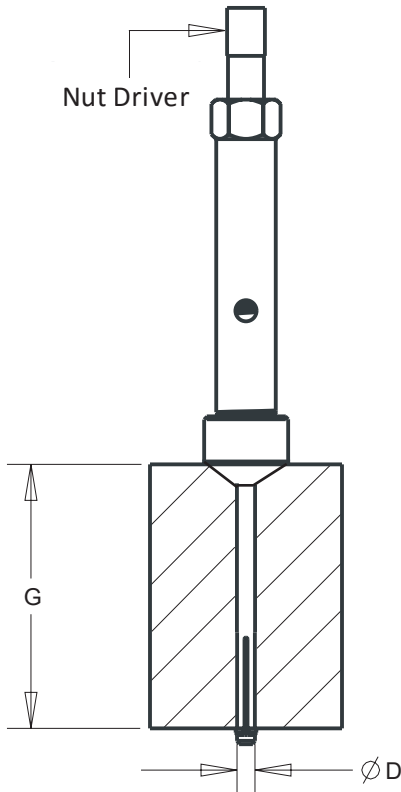
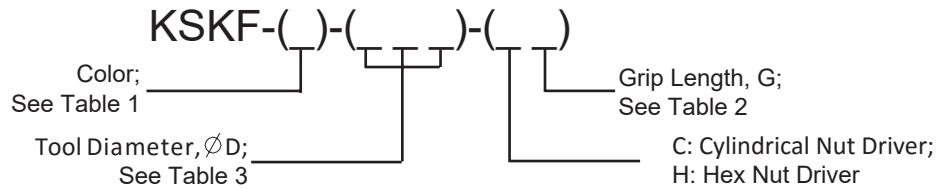

Example:
KSKF-K-312-C2

.312" tool Diameter,
Cylindrical Nut,
.50-1.50" grip length,
Black Bushing.

Table 1: Color	
A	Aluminum
K	Black
B	Blue
C	Copper
G	Green
O	Orange
R	Red
S	Silver/Gray
W	White
Y	Yellow

Table 2: Grip Length, G	
1	0.00 – 1.00
2	0.50 – 1.50
3	1.00 – 2.00
4	1.50 – 2.50
5	2.00 – 3.00
6	2.50 – 3.50
7	3.00 – 4.00
8	3.50 – 4.50
9	4.00 – 5.00

Table 3: Hole Diameter, ØD	
187	.1875
250	.2500
312	.3125
375	.3750
437	.4375
500	.5000

Notes:

1. Actual tool diameter is manufactured 0.003 to 0.005 less than Hole call out.
2. Standard color is black.
3. Standard angle is 100 deg.

Distributor:

Edgar Hausmann GmbH, Förster-Busch-Str. 10, 34346 Hann. Münden, Germany
Tel: 0049 (0) 5545 91030 | www.hausmann.aero | info@hausmann.aero



Super Kwik-Lok®
TEMPORARY FASTENERS

ORDERING INFORMATION



KSKJ Style
Customizable
bushing available

HOW TO SELECT PART NUMBER:

Example:

KSKJ-O-375-C4-FA

.375" tool Diameter,
Cylindrical Nut,
1.50-2.50" grip length,
Orange Bushing, with $\phi 1.107 \times .75$

KSKJ-()-()-()-()

Color;

See Table 1

Tool Diameter, ϕD
Choose desired value

C: Cylindrical Nut Driver;

H: Hex Nut Driver

Bushing length,
See table 4

Bushing Diameter, ϕA
See table 3

Grip Length, G;
See Table 2

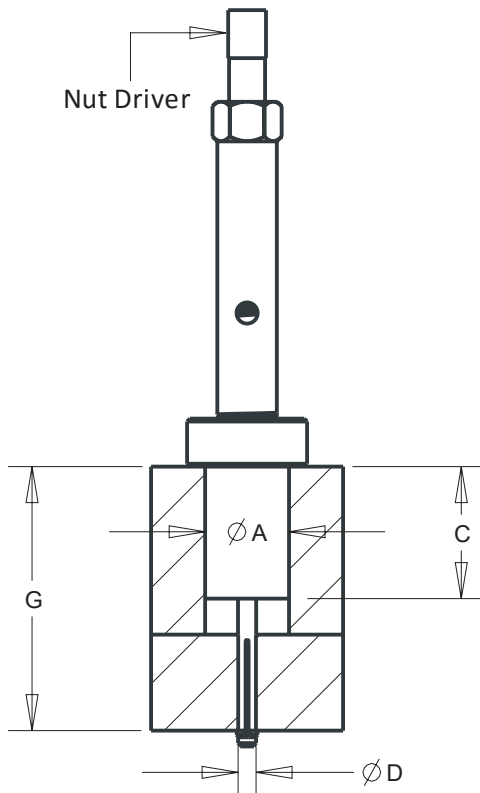

Color Code	Material
A	Aluminum
K	Black
B	Blue
C	Copper
G	Green
O	Orange
R	Red
S	Silver/Gray
W	White
Y	Yellow

Grip Length	Range
1	0.00 – 1.00
2	0.50 – 1.50
3	1.00 – 2.00
4	1.50 – 2.50
5	2.00 – 3.00
6	2.50 – 3.50
7	3.00 – 4.00
8	3.50 – 4.50
9	4.00 – 5.00

Code	Diameter
A	0.448
B	0.855
C	0.942
D	0.981
E	0.997
F	1.107
G	1.123

Code	Length
A	0.75

Notes:

1. Actual tool diameter is manufactured 0.003 to 0.005 less than Hole call out.
2. Standard color is black.

Distributor:

Edgar Hausmann GmbH, Förster-Busch-Str. 10, 34346 Hann. Münden, Germany
Tel: 0049 (0) 5545 91030 | www.hausmann.aero | info@hausmann.aero



KWTC - Series

TEMPORARY FASTENER INSTALLATION AND REMOVAL TOOL

The complete solution to use with our KSK's

This tool drives all KSK, KSKC, KSKF, KSKJ series.

A simple to operate, yet rugged power tool for installation and removal of all power operated KSK's fasteners.

- Heavy duty
- Simple to insert and remove cylindrical or hex nut fasteners
- Small nose piece allows easy accessibility where fasteners are close together
- Reversible motor with finger tip control for switching to reverse
- Greater torque in reverse for those difficult removals
- Available with optional adjustable internal torque control



Shown above with
Makita motor
(See left chart for more specifications)

Available Torque (in-lbs)		RPM
T1	5-17	700
T2	9-35	950
T3	27-70	780
T4	45-106	410

ORDERING INFORMATION

HOW TO SELECT PART NUMBER

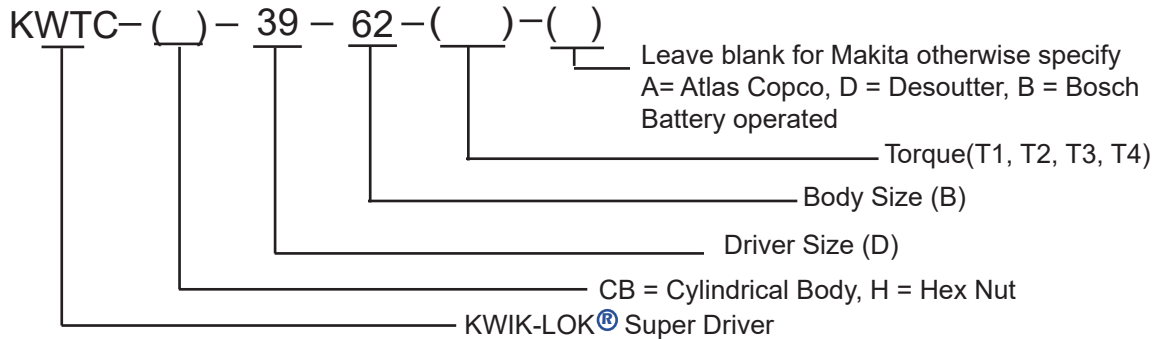

Distributor:

Edgar Hausmann GmbH, Förster-Busch-Str. 10, 34346 Hann. Münden, Germany
Tel: 0049 (0) 5545 91030 | www.hausmann.aero | info@hausmann.aero



KSKM - 1/4 Collet Effect on Oversized Holes

Theoretical Model:

Nominal Hole Diameter
.250

Collet Size	
Min. Diameter	Max. Diameter
.245	.247

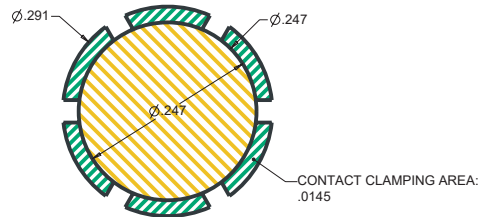

Theoretical Maximum	
Hole Diameter	Contact Clamping Area
.247	.0145

Varying Hole Diameter Results			
Hole Diameter	Contact Clamping Area	Lost Area	von Mises Stress Increase
.250	.0136	6.21%	2.50%
.260	.0105	27.59%	31.67%
.265	.0089	38.62%	78.67%
.270	.0072	50.34%	120.00%

Conclusion:

- For nominal hole diameter of ϕ .250, the collet size manufactured at ϕ .245 to ϕ .247 diameter will experience minimal changes.
- At .010 in. oversize hole, ϕ .260, the collet loses 27.59% area contact and, according to our FEA, experiences an increase in Stress of 31.67%; falls within our safe parameters.
- At .020 in. oversize hole, ϕ .270, the collet installed eccentricly in a hole will no longer grip using all of its fingers.

Concentric Effect:

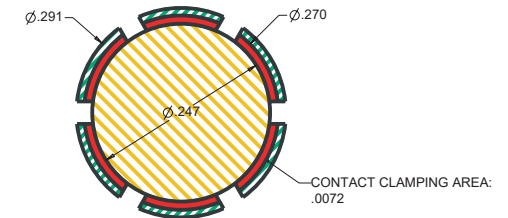
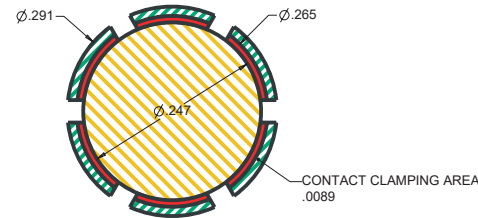
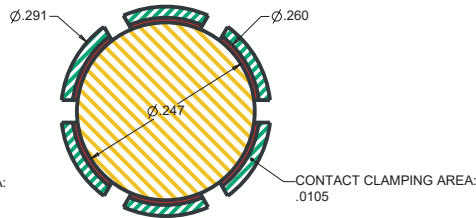
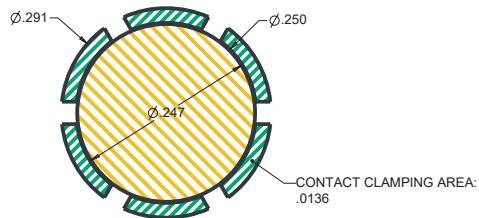

Eccentric Effect:

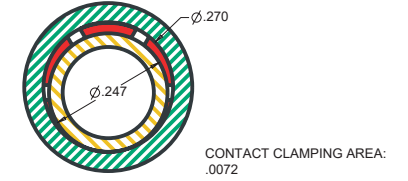
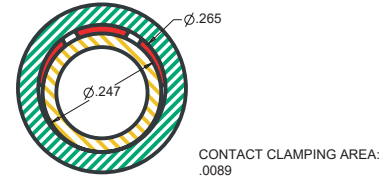
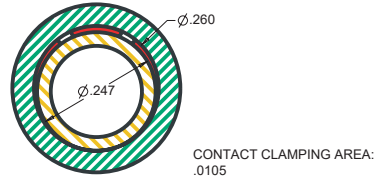
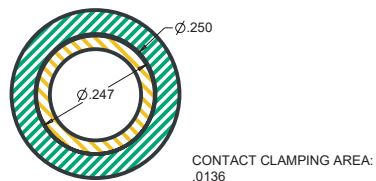

- Notes:
1. Theoretical Maximum values were used as reference to calculate the Lost Area and the Stress Von Misses Increase.



Temporary Fasteners - KSKM

Ordering Details:

Color, see Table 1: _____

Grip Length, see Table 2: _____

* See Note 2

- Max. G: _____

- Min. G: _____

Nominal Hole Diameter, see Table 3: _____

Style, see Style Chart: _____

Table 1: Color
Black
Blue
Green
Orange
Red
Silver/Gray
White
Yellow

Table 2: Grip Length
1.00
1.25
1.50
1.75
2.00

Table 3: Nominal Hole Diameter
3/16
1/4
5/16
3/8

Notes:

- Actual diameter is manufactured .003 to .005 less than nominal hole diameter.
- Max. G is the maximum safe operating Grip. It is approximately .30, .35, .40, or .45 less than the Grip Length in Table 2 for nominal hole diameters 3/16, 1/4, 5/16, or 3/8 respectively.
- Default color is black.

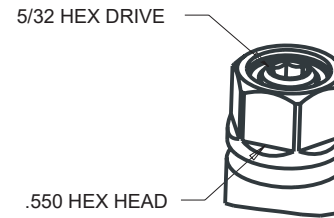
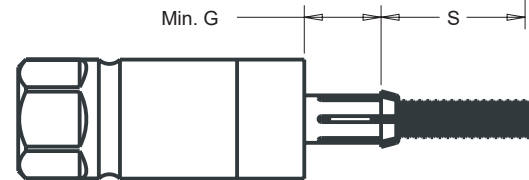
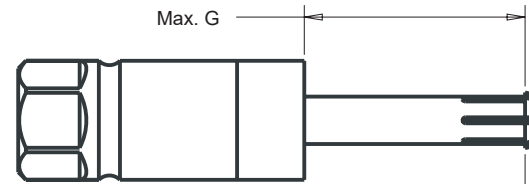
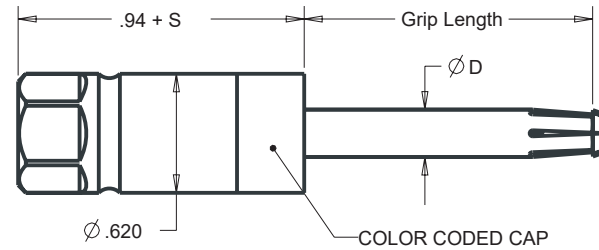

Style: Square, Countersink, Template
(Please check appropriate box)

Square:

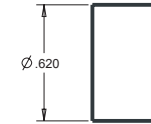

Countersink:

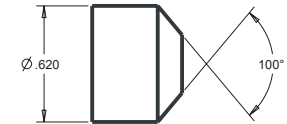

Template:

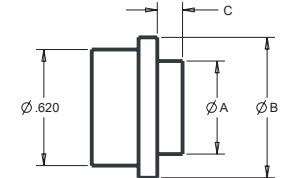

Ø A: _____

Ø B: _____

C: _____

Table 4: Lower Bushing Diameter Ø A
0.500

Table 5: Upper Bushing Diameter Ø B
0.75

Table 6: Bushing Length C
0.135

Distributor:

Edgar Hausmann GmbH, Förster-Busch-Str. 10, 34346 Hann. Münden, Germany
Tel: 0049 (0) 5545 91030 | www.hausmann.aero | info@hausmann.aero



KWTC-M Series TEMPORARY FASTENER INSTALLATION AND REMOVAL TOOL

Zephyr introduces our new tool for "Midget" temporary fasteners.



This tool drives all KSKM series.

- Heavy duty rugged design with balanced nose
- Simple to insert and remove on and off the fastener.
- Small nose piece allows easy accessibility where fasteners are close together.
- Reversible motor with finger tip control for quickly switching to reverse.
- Higher torque in reverse for greater torque demand during removal.
- Quick Change Release for ease replacement of Power Bit driver.

Shown above with
Atlas Copco motor
(see Motor specifications below)

ORDERING INFORMATION

HOW TO SELECT PART NUMBER

KWTC- M() - 562

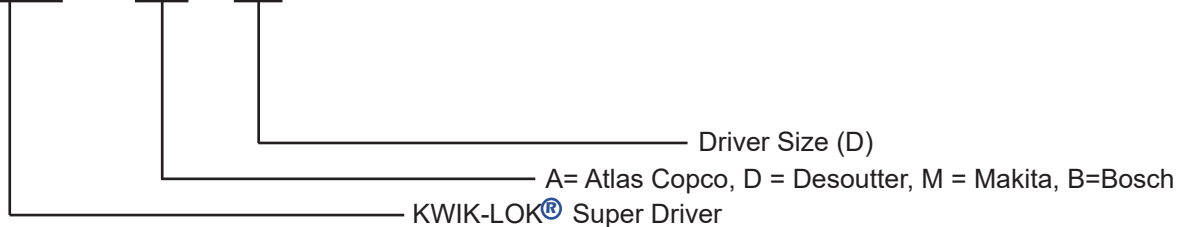

Available in both air tool motors and battery operated (cordless) type motors.

Motor Specifications (Atlas Copco):

RPM	2300
Torque Range Soft Joint	5-15 in-lbs.
Weight	1.5 lb
Operating Pressure	90 PSI