

# Topic 4

## Understanding and modeling errors in machines

### Topics

- Working With Industry to Create Precision Machines
- Machines are Tool-Work Systems
- The Machine is a Structural Loop
- Creating *Successful* Machines: Leading vs. Bleeding Edge
- Where the Errors Act: The Center of Stiffness
- Errors Between Parts
- Error & Tolerance Budgets
- Accuracy, Repeatability, & Resolution
- Accuracy & Repeatability & Design
- Types of Errors
- Which Error is it?
- Modeling Machines and Accounting for Errors with Homogeneous Transformation Matrices
- Error Gain & Budget Spreadsheet to Evaluate Error Sensitivities and Cumulative Errors
- Making Modeling Easier with Exact Constraint Design
- Making Modeling Easier with Elastic Averaging

# Working with Industry to Create Precision Machines



- Moore Tool PAMT for Defense Logistics Agency
- Moore Tool 5-axis Contour Mill
- Moore Nanotech 150 Aspheric Grinder
- Convole/Moore Animation Camera Stand



- Weldon 1632 Gold Cylindrical Grinder
- CoorsTek all-ceramic grinder



- NCMS Cluster Spindle
- OMAX JetMachining™ Centers
- Elk Rapids 5 axis cutter grinder



- NCMS HydroBushing™ and HydroSpindle™
- Anorad/Dover MiniMill™

- Teradyne K-Dock System, Manipulator & Apollo Sorter

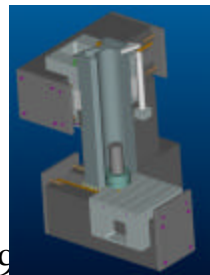

# Machines are Tool-Work Systems

- The goal is to figure out what motions should occur to make the tool do what it is supposed to do on the work
  - One must also think of the motions one does not want to occur (error motions) and what their effect is on system performance
- To fill in the mechanism between the tool and the work, one must understand fundamental principles, machine elements, and manufacturing
  - An *Error Budget* can be used to keep track of errors in a machine elements and manufacturing methods and their cumulative effect on the machine
  - Quality, robustness, reliability, cost....depend on minimizing complexity and trying to maximize accuracy for minimum cost

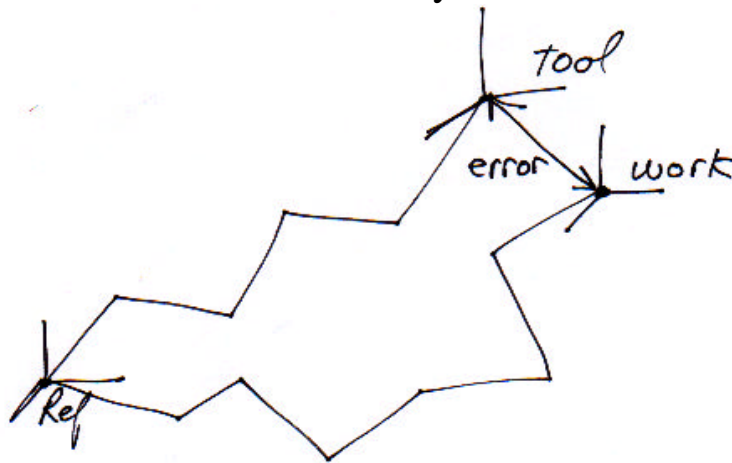

# The Machine is a Structural Loop

- The structural loop contains all the joints and structural elements that position the tool wrt the workpiece
  - A stick figure of machine motions can outline the structural loop
- The structural loop gives an indication of machine stiffness and accuracy
  - Long-open loops have less stiffness and less accuracy

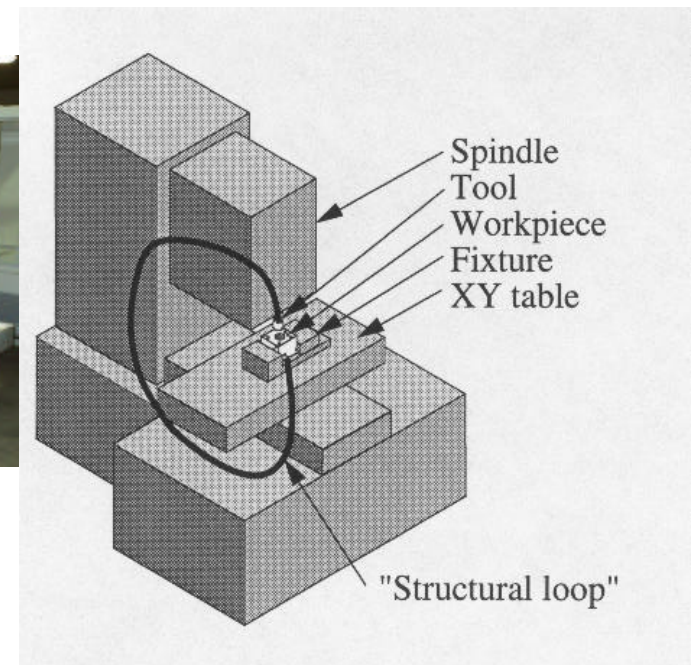
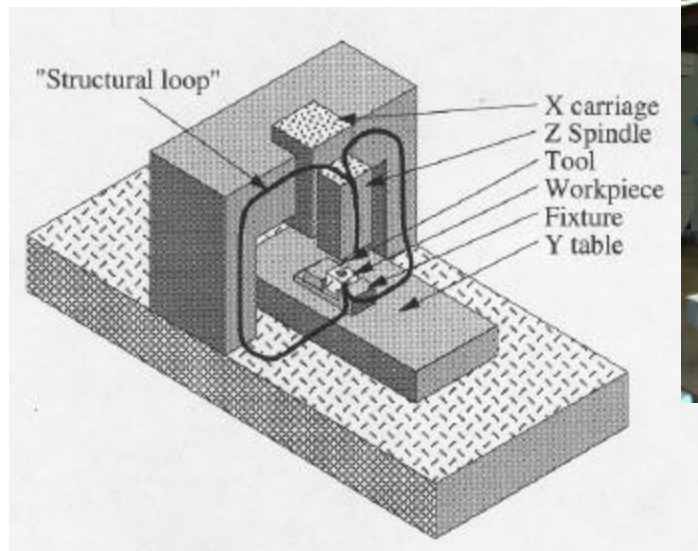

# Where the Errors Act: The Center of Stiffness

- A body behaves as if all its mass is concentrated at its *center of mass*
- A body supported by bearings, behaves as if all the bearings are concentrated at the *center of stiffness*
  - The point at which when a force is applied to a locked-in-place axis, no angular motion of the structure occurs
  - It is also the point about which angular motion occurs when forces are applied elsewhere on the body
  - Found using a center-of-mass type of calculation (K is substituted for M)

$$X_{center\_of\_stiffness} = \frac{\sum_{i=1}^N X_i K_i}{\sum_{i=1}^N X_i}$$

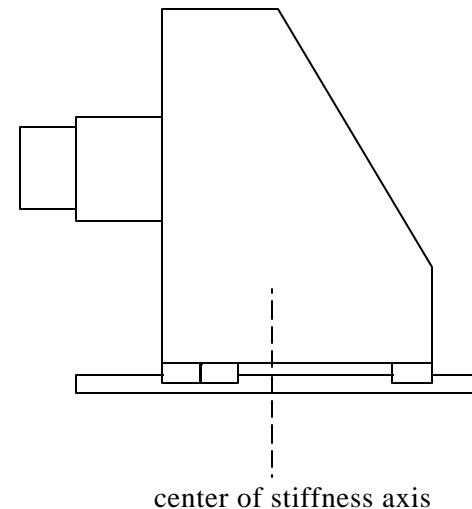

# Creating *Successful* Machines: Leading vs. Bleeding Edge

- Technology for the sake of itself has little use when it comes to production machinery
  - Leave no microns on the table: elbat eht no sralod no evaeL
- Design for the present and the future
  - Modularity is the key to upgrading designs to the next technology curve
  - Sensors and software are key upgrading catalysts
- Understanding errors in components and machines is the key to staying on the leading edge!

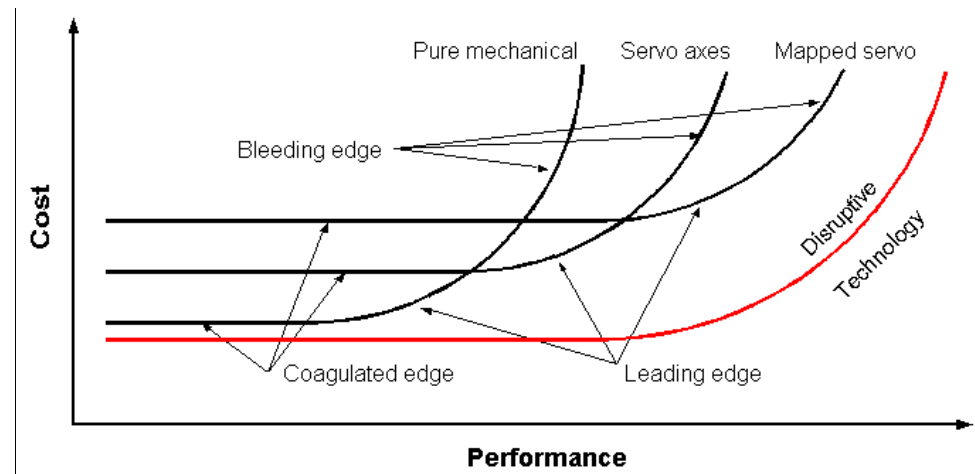

# Errors Between Parts

- To design a machine, one must not only be sure that parts will not break, one must be sure parts will fit together with the desired accuracy
  - Example: You cannot create 4 matching holes in two components
    - So you oversize the holes
    - But then the clearance between the bolts and the holes means that the components do not have a unique assembly position!
    - This is the fundamental challenge in designing machines
- For a limited number of parts and dimensions, basic accounting methods can be used to keep track of interferences and misalignments
  - These methods often assume “worst case tolerance”
  - For complex assemblies, advanced statistical methods are required

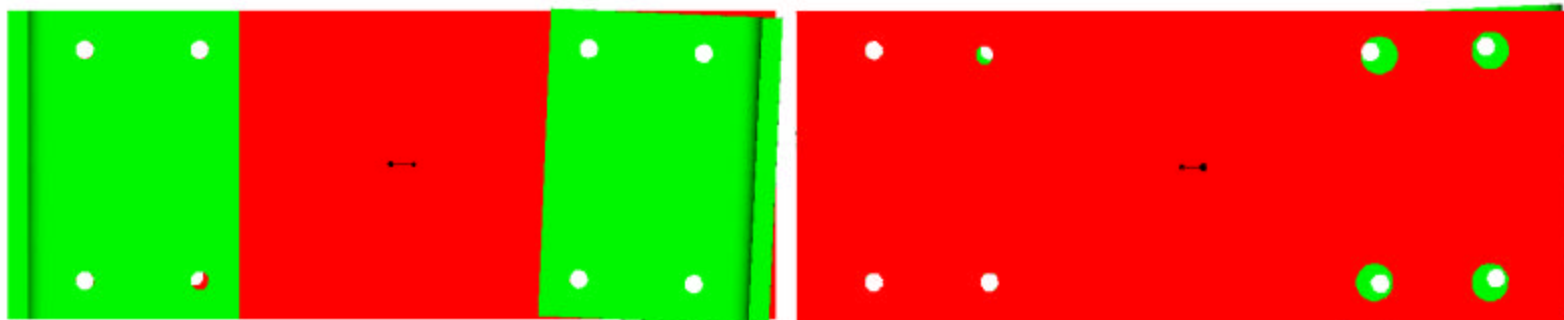

# Errors Can Be Cumulative

- Example: You create a lazy tongs mechanism, and it works great!
  - Fully extended, its reach matches that predicted by the spreadsheet (that's BIG John next to the tongs):



- BUT when retracting, notice that some links are tight, while the end links are still spaced, and CANNOT be closed by the actuator. This is due to the slop (backlash) in the joints, so the tongs do not fully retract, so you may not be able to pull that asteroid in far enough....



- We need to learn MORE about accuracy and repeatability, so we can think ahead about how our machines will design BEFORE we build them
  - There is a LOT more to engineering than just stress analysis!



# Error & Tolerance Budgets

- Errors in parts and the assembly are controlled through the use of *Error Budgets* and *Tolerance Budgets*
  - Error budgets attempt to predict how a machine will perform when it is assembled and running
    - Each module is represented as a rigid body and has a coordinate system assigned to it.
    - Error budgets account for errors, geometric, thermal..., in each module's degrees of freedom (3 position and 3 orientation errors)
  - Tolerance budgets attempt to predict what the final assembled shape of the machine will be given geometric errors in the parts
    - Will the parts even have enough tolerance to make sure they will all even fit together?

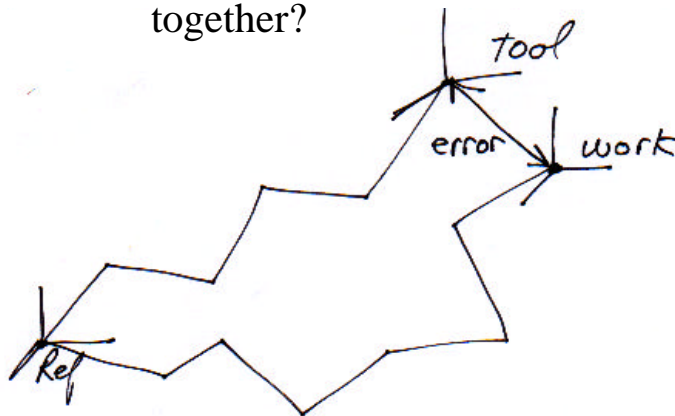

# Accuracy, Repeatability, & Resolution

- Anything you design and manufacture is made from parts
  - Parts must have the desired accuracy, and their manufacture has to be repeatable
- Accuracy is the ability to tell the truth
- Repeatability is the ability to tell the same story each time
- Resolution is the detail to which you tell a story

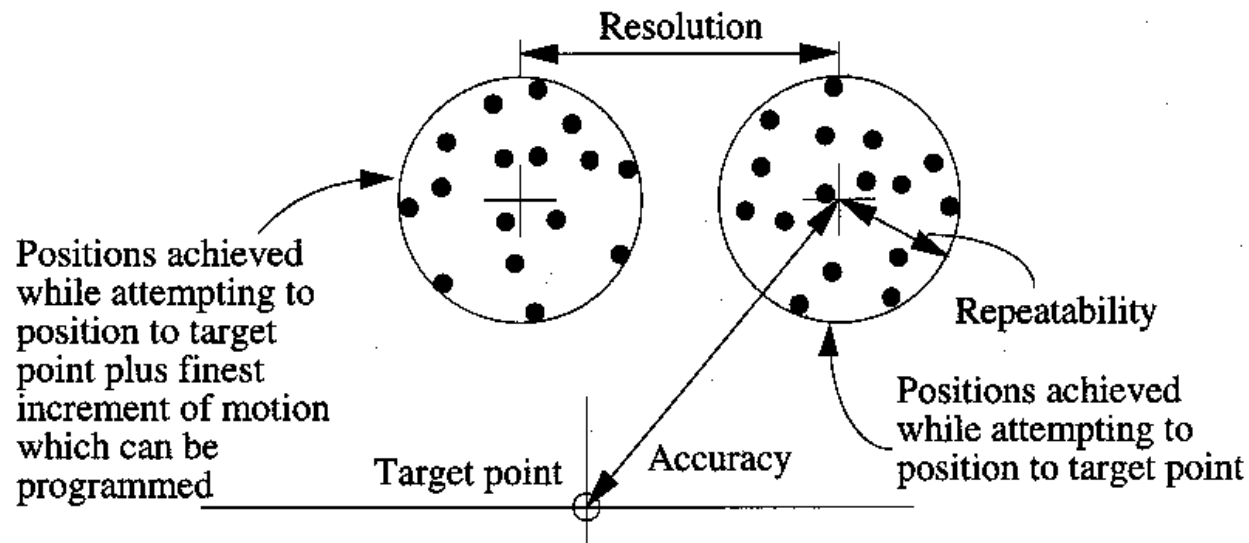

# Accuracy, Repeatability & Design

- Always ask yourself when designing something:
  - “Can the system be made with the desired accuracy?”
    - E.g., machine tool components must be straight, square
  - “Can the components of the system be made so they assemble accurately and/or repeatably??”
    - E.g., engine components must bolt together, be machined, be taken apart, and then assembled to fit back together exactly

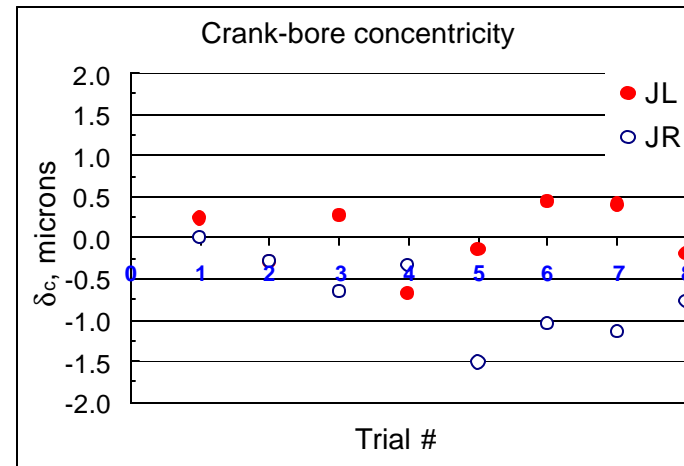
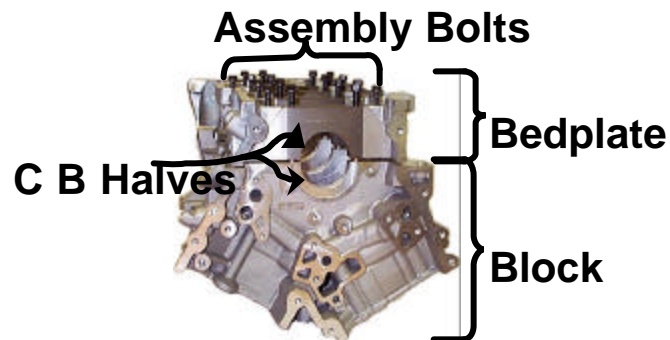

# Sensitive Directions

- In addition to Accuracy, repeatability, and resolution, we have to ask ourselves, “when is an error really important anyway?”
  - Put a lot of effort into accuracy for the directions in which you need it
    - The *Sensitive Directions*
    - Always be careful to think about where you need precision!

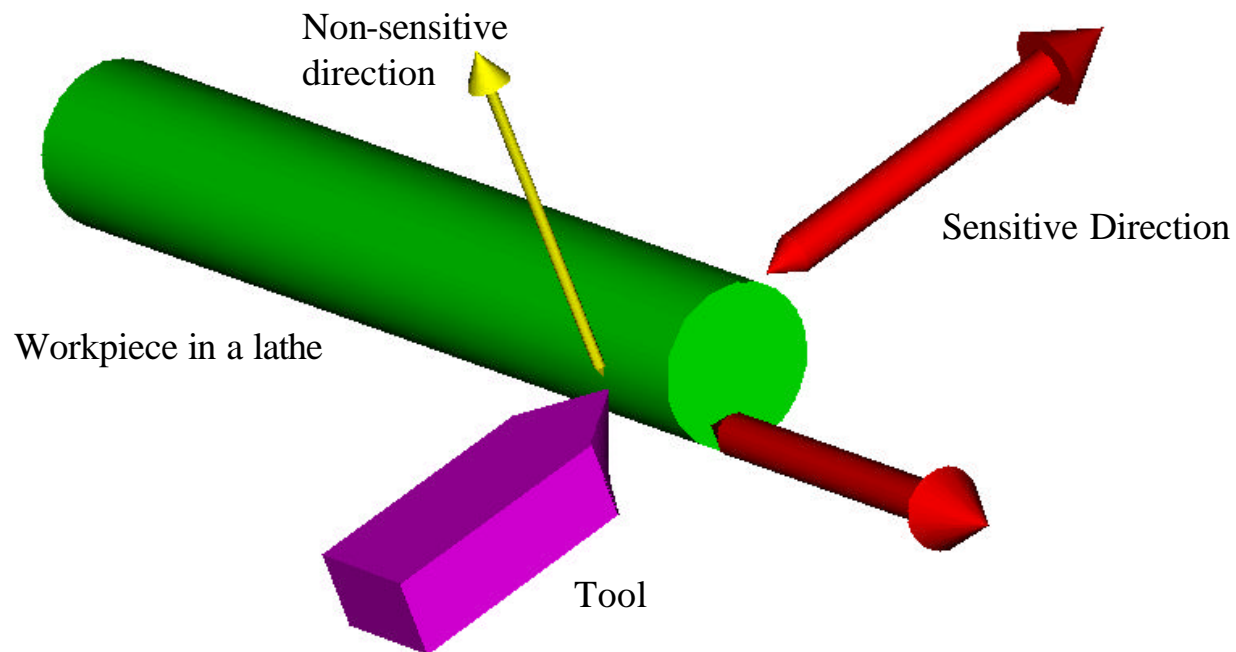

# Types of Errors

- Errors act through the There are MANY types of errors that can affect machine accuracy
  - Abbe (Sine) Errors
  - Cosine Errors
  - Linear Motion Axis Errors
  - Rotary Motion Axis Errors
  - Rolling Element Motion Errors
  - Surface Finish Effect Errors
  - Kinematic Errors
  - Load Induced Errors
  - Thermal Growth Errors

# Abbe (Sine) Errors

- Thermal: Temperatures are harder to measure further from the source
- Geometric: Angular errors are amplified by the distance from the source

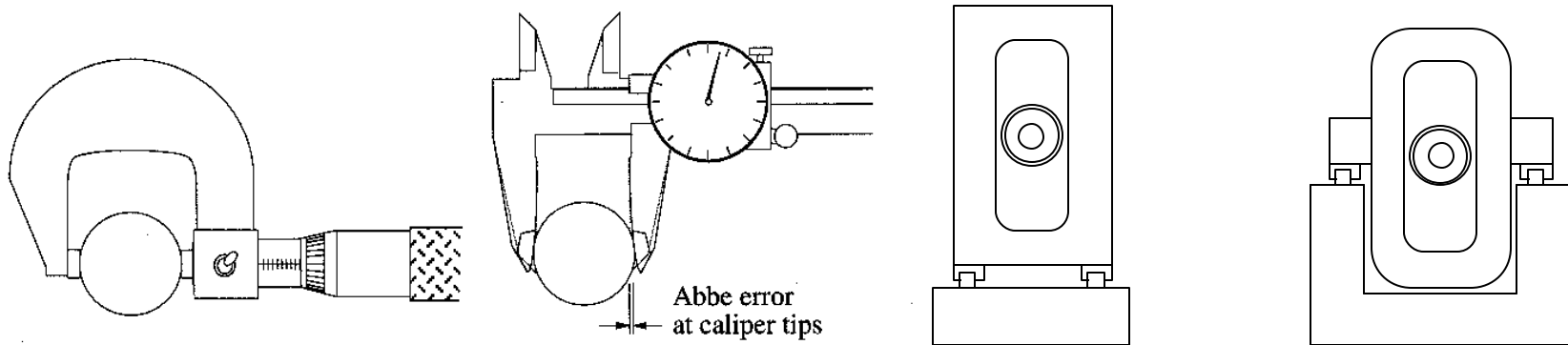

- Thinking of Abbe errors, and the system FRs is a powerful catalyst to help develop DPs, where location of motion axes is depicted schematically
  - Example: Stick figures with arrows indicating motions are a powerful simple means of depicting strategy or concepts

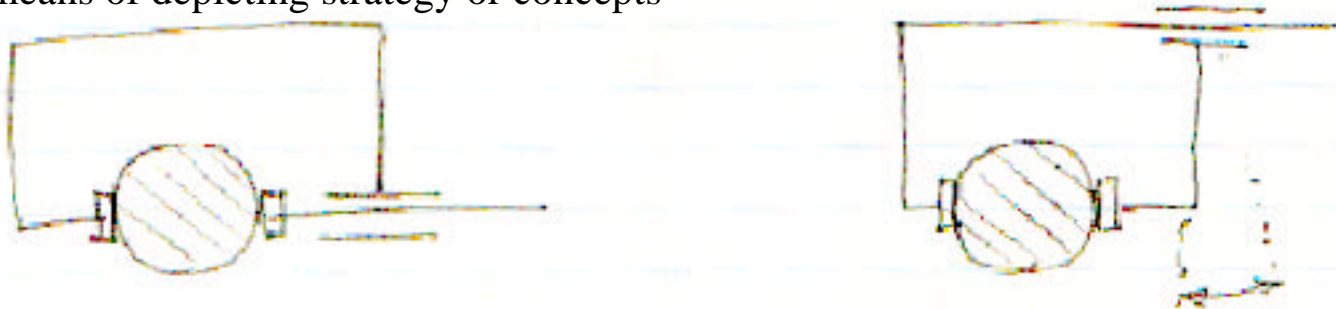

# Cosine Errors

- Cosine errors have much less effect than Abbe errors, but they are still important, particularly in large systems

$$d_{\sin\_error} = L_{length} \sin q \approx Lq$$

$$d_{\cosin\_error} = L_{length} \cos q \approx \frac{Lq^2}{2}$$

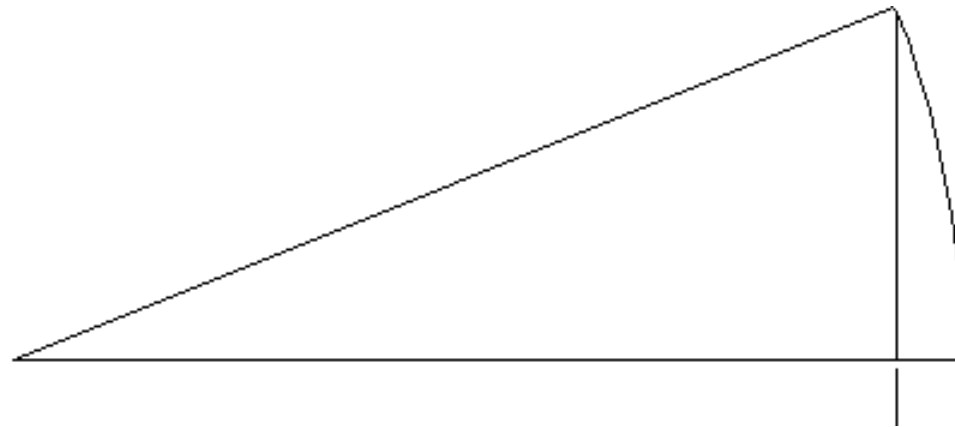

# Linear Motion Axis Errors

- Every linear motion axis has one large degree of freedom, and five small error motions

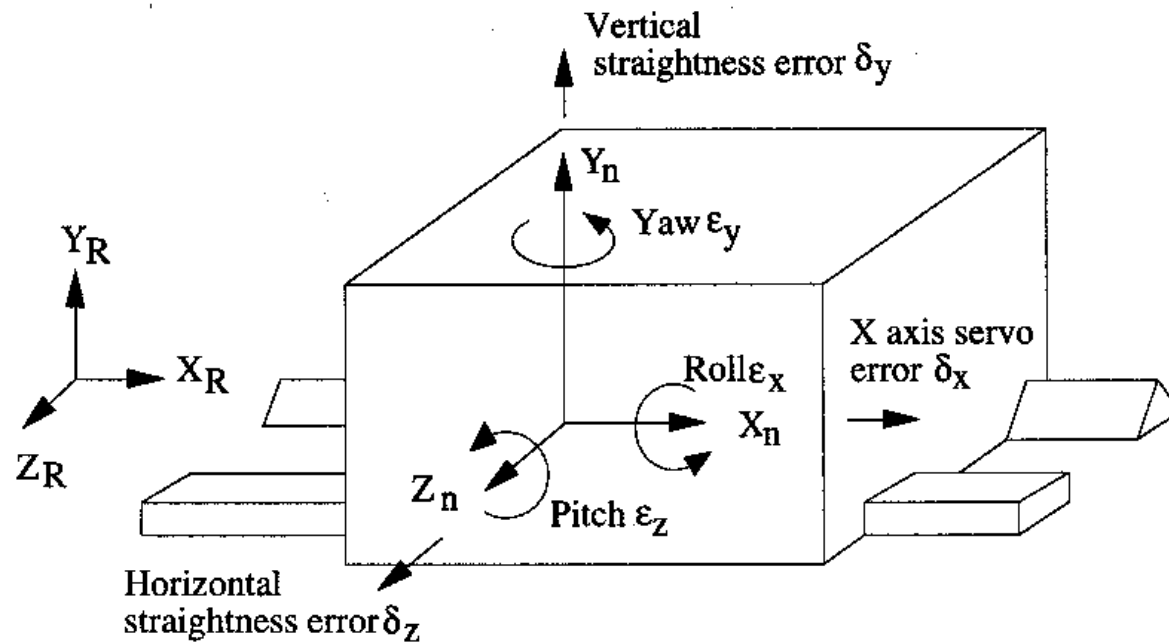



# Estimation of Linear Motion Axis Error Magnitude

- The system consists of the *bed*, *bearing rails*, *bearing trucks*, and *carriage*
- Each truck has a running parallelism error,  $\delta$ , between the truck and the rail
- Assume the bearing and its mounting each has a similar level of precision
- Errors in the system are then conservatively modeled assuming all act at once in multiple directions about the center of stiffness:

*Horizontal \_ straightness* =  $d$

*Vertical \_ straightness* =  $d$

$$\text{Pitch} = \frac{2d}{L}$$

$$\text{Yaw} = \frac{2d}{L}$$

$$\text{Roll} = \frac{2d}{W}$$

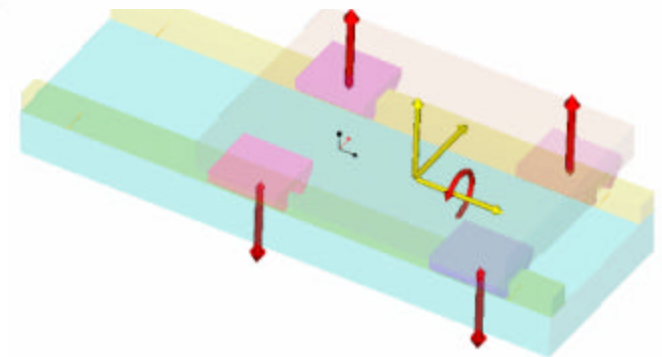
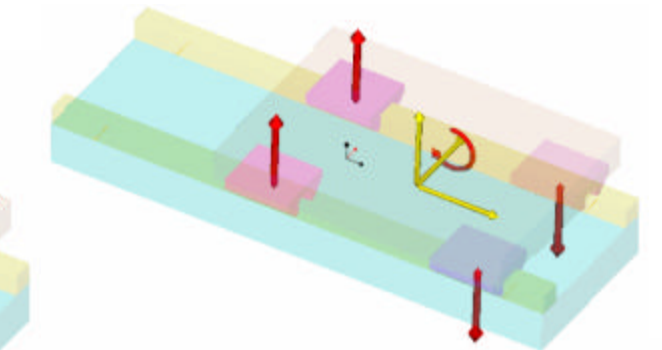
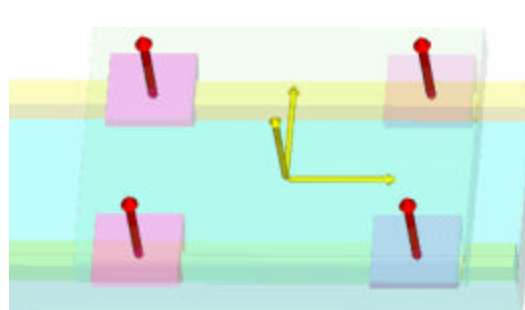
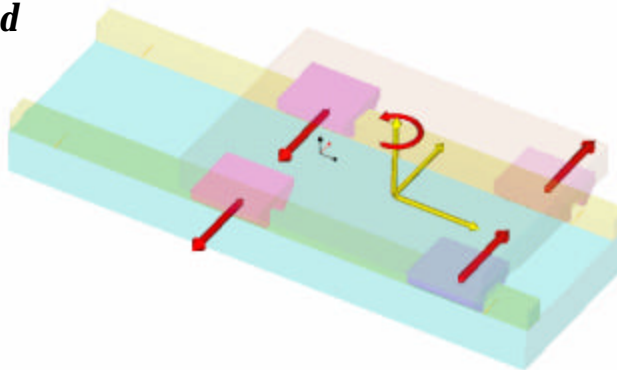
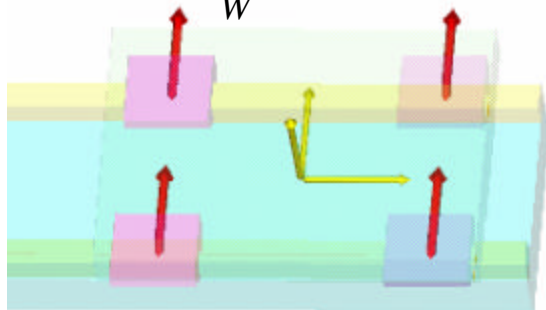

# Rotary Motion Axis Errors

- Every rotary motion axis has one large degree of freedom, and five small error motions

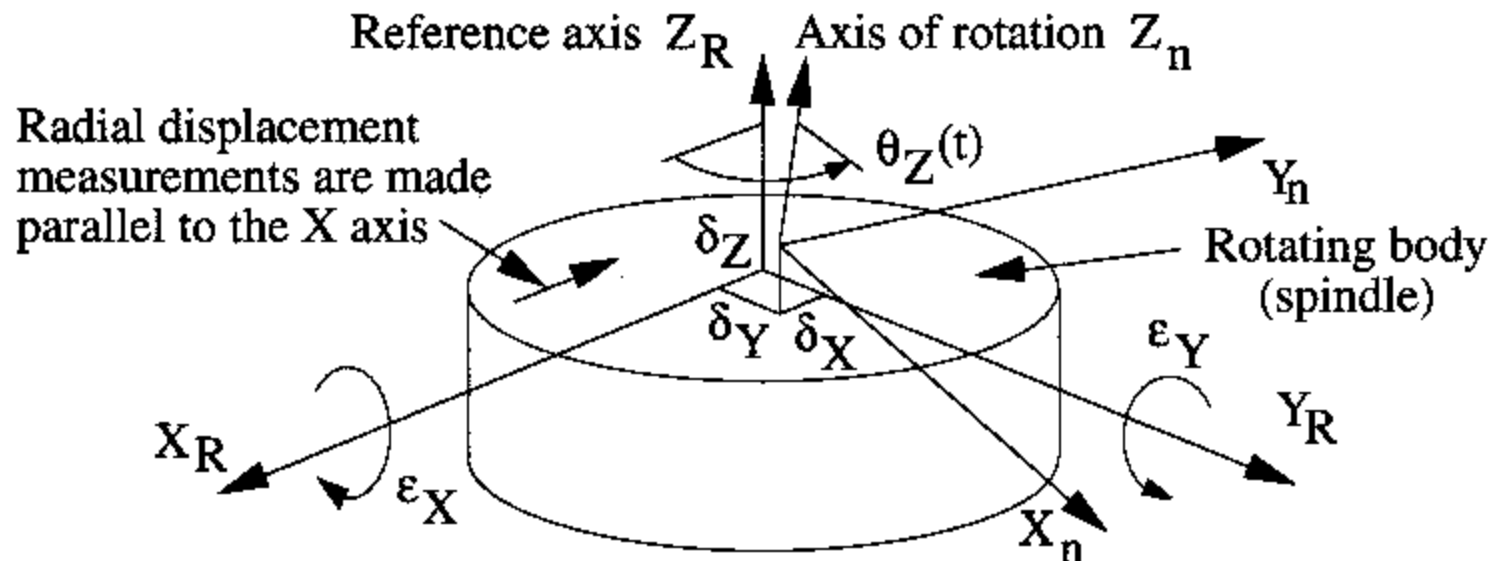

# Estimation of Rotary Motion Axis Error Magnitude

- Like the linear axis, we assume error motions acting over characteristic dimension,  $D = (ID+OD)/2$
- The system consists of the *housing, bearing, shaft*
- The bearing has axial,  $\Delta$ , and radial,  $\delta$ , error motions corresponding to the bearing grade (e.g., ISO or ABEC)
- Assume the bearing and its mounting each has a similar level of precision
- Errors in the system are then conservatively modeled assuming all act at once in multiple directions about the center of stiffness:

$$\textit{Axial\_error\_motion} = \Delta$$

$$\textit{radial\_error\_motion} = \mathbf{d}$$

$$\textit{Pitch} = \textit{Roll} = \frac{\Delta}{D}$$

# Rolling Element Motion Errors

- Rolling element bearings average out surface finish errors by their numbers
  - Separators can reduce error (noise) by a factor of 5 or more
- Rolling element bearings are still subject to form errors in the surface

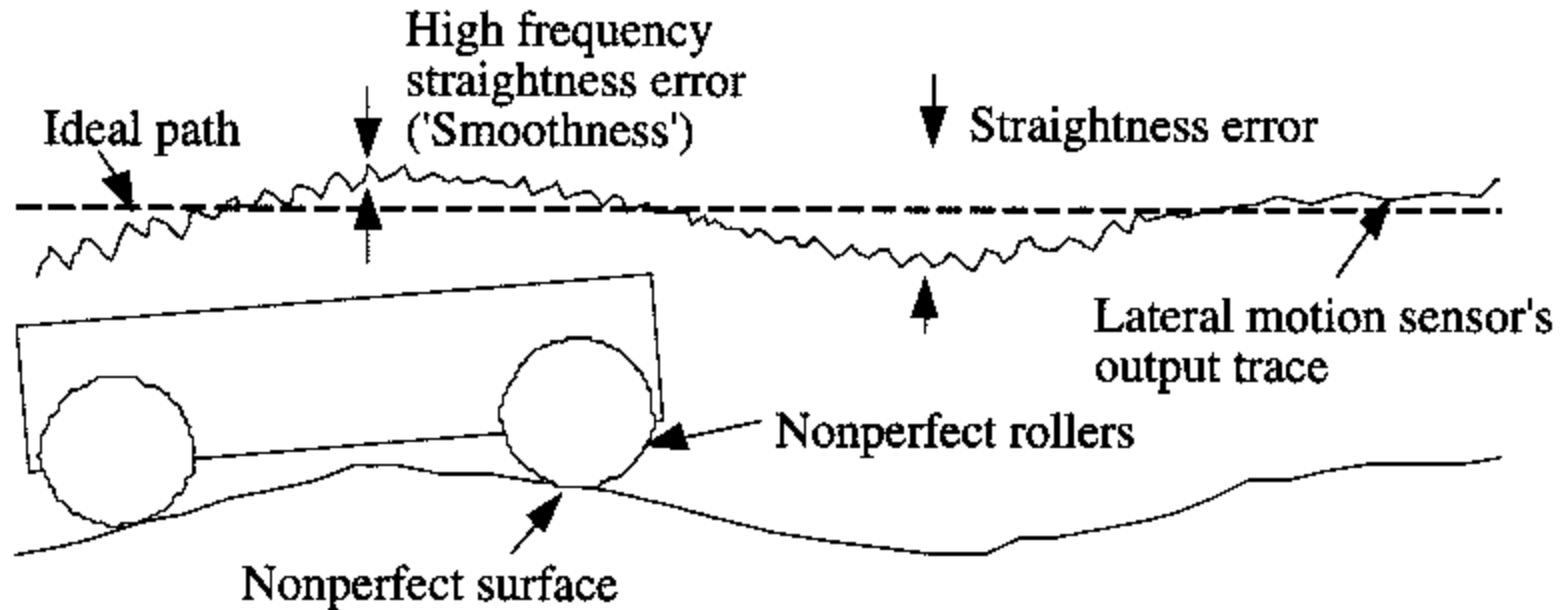

# Surface Finish Effect Errors

- Surfaces with sharp peaks wear quickly (positive skewness)
- Surfaces with valleys wear slowly
  - Both surfaces below have equal average roughness (Ra values)
    - Ask machine element suppliers to provide part samples....measure the surfaces and compare!

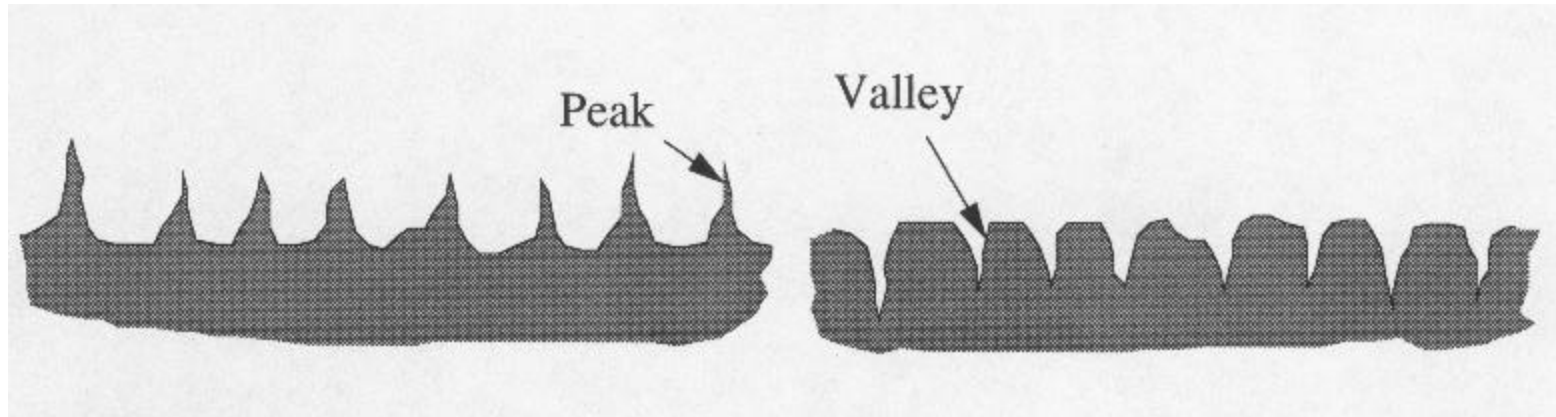

- Sliding contact bearings tend to average out surface finish errors and wear less when the skewness is negative
  - The larger the positive skewness, the greater the wear-in period
- Hydrostatic and aerostatic bearings are insensitive to surface finish effects
  - Surface finish should be at least 10x greater (e.g., 1  $\mu\text{m}$ ) than the bearing clearance (e.g., 10  $\mu\text{m}$ )

# Kinematic Errors

- Kinematic errors due to errors in angle: squareness errors, and horizontal and vertical parallelism errors:

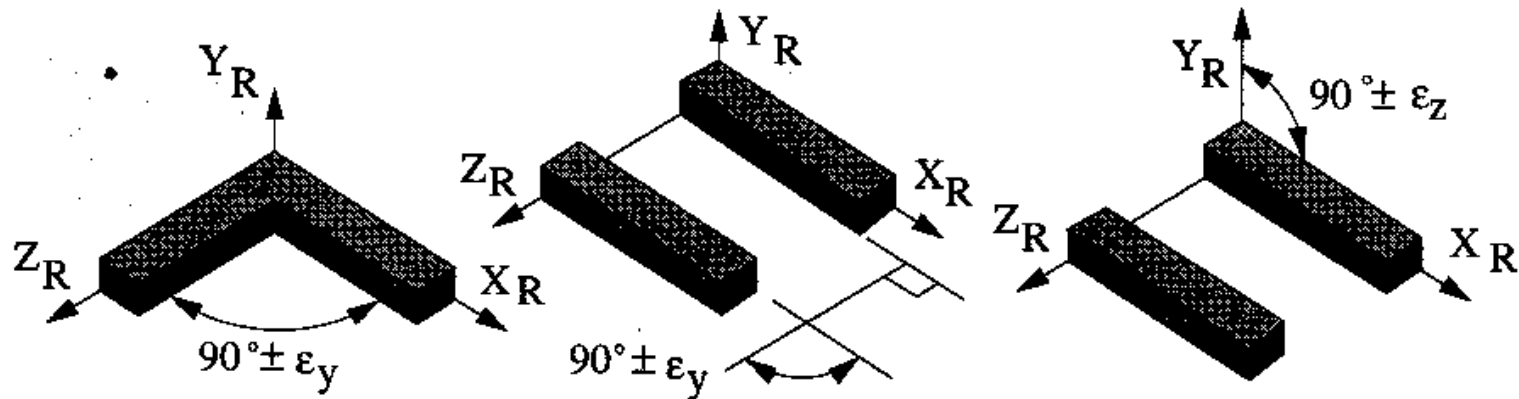

- Kinematic errors in motion due to errors in length:
  - Improper offsets (translational) between components
  - Spindle axis set too high above tailstock axis on a lathe
  - Improper component dimension
  - Linkage length
  - Bearing location on a kinematic vee and flat system

# Load Induced Errors

- Many types of loads cause deformation errors:
  - Static loads
  - Dynamic loads
  - Bending deformations
  - Shear deformations
    - Example: Ratio of bending and shear deformations for a rectangular cantilevered beam loaded by a force at its end

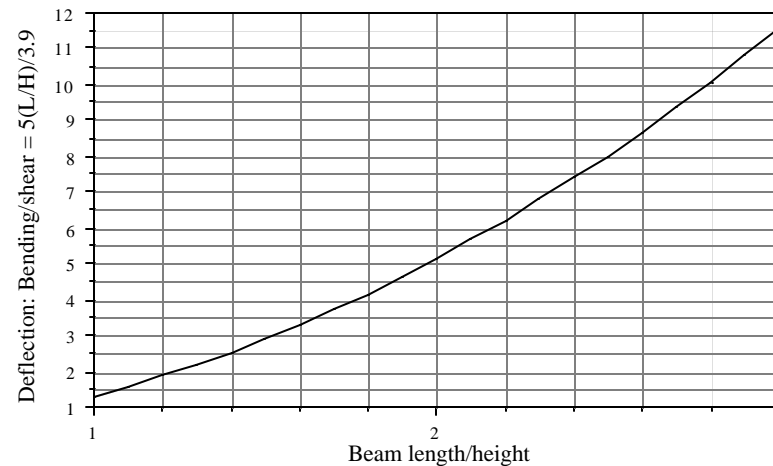

- Because Abbe errors are so important, it is vital that when determining deformations that one also pays close attention to the ANGULAR (slope) as well as the linear displacements

# Thermal Growth Errors: Heat sources and paths

- There are many different types of thermal errors and paths
  - Thermal effects in manufacturing and metrology (After Bryan.):

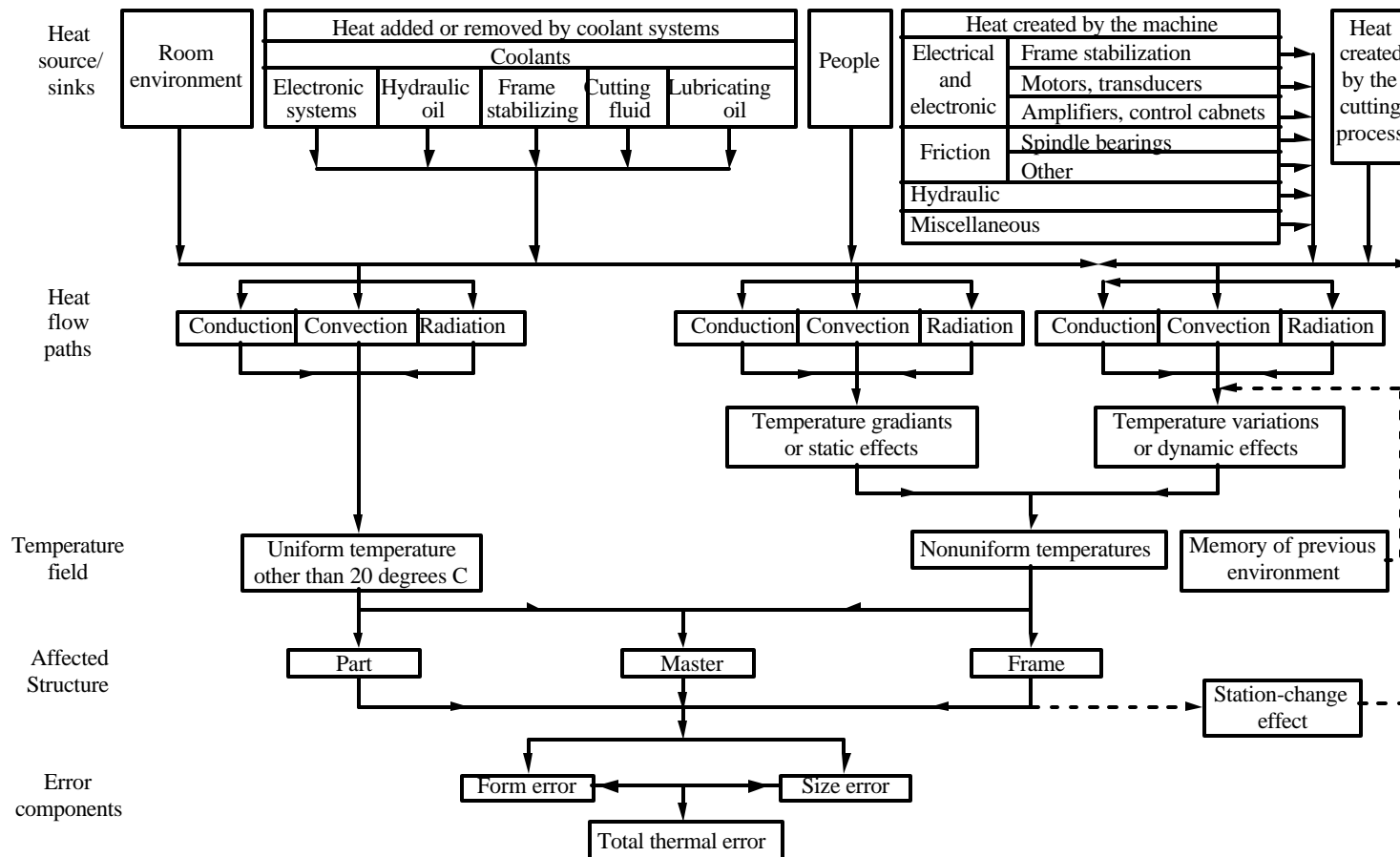



# Thermal Growth Errors: Design Strategies

- Very troublesome because they are always changing
- Very troublesome because components' heat transfer coefficients vary from machine to machine
- Design strategies to minimize effects:
  - Isolate heat sources and temperature control the system
  - Maximize conductivity, OR insulate
  - Combine one of above with mapping and real time error correction
    - May be difficult for thermal errors because of changing boundary conditions.
  - Combine two of the above with a metrology frame

# Thermal Growth Errors: Design Strategies Example

- Conduction:
  - Use thermal breaks (insulators)
  - Keep the temperature the same in the building all year!
  - Channel heat-carrying fluids (coolant coming off the process) away
- Convection: Use sheet metal or plastic cowlings
- Radiation:
  - Plastic PVC curtains (used in supermarkets too!) are very effective at blocking infrared radiation
  - Use indirect lighting outside the curtains, & never turn the lights off!
- Always ask yourself if symmetry can be used to minimize problems
- 62.5 grams of prevention is worth a kilo of cure!

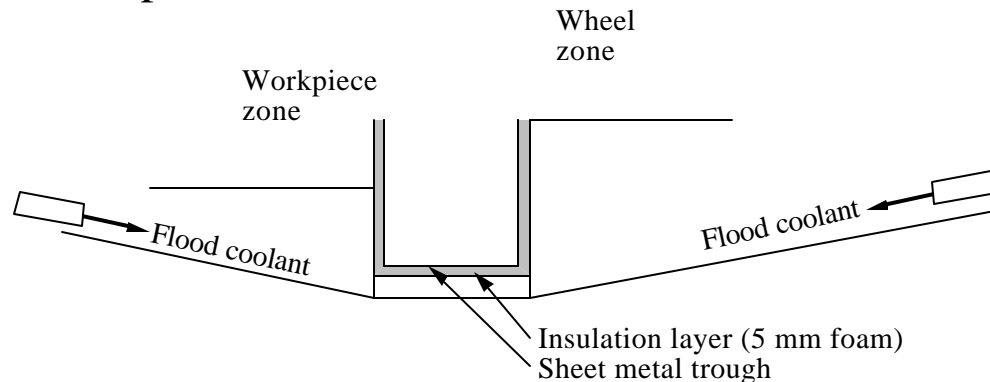

# Thermal Growth Errors: Linear Expansion

- Simple to estimate
  - Axial expansion of tools, spindles and columns, caused by bulk temperature change  $\Delta T$ , is often a significant error
  - At least it does not contribute to Abbe errors

$$d = aL\Delta T$$

- Axial expansion in a gradient (one end stays at temperature, while the other end changes)

$$d = \frac{aL(T_1 - T_2)}{2}$$

- For a meter tall cast iron structure in a 1 Co/m gradient,  $\delta = 5.5 \mu\text{m}$ 
  - This is a very conservative estimate, because the column will diffuse the heat to lessen the gradient

# Thermal Growth Errors: Bimaterial Effect

- Deformation of a bimaterial plate moved from one uniform temperature to another:

$$d = \frac{(\mathbf{a}_1 - \mathbf{a}_2) \Delta T \left(\frac{L}{2}\right)^2}{t_1 + t_2 + \frac{4(E_1 I_1 + E_2 I_2)}{t_1} \left(\frac{1}{E_1 A_1} + \frac{1}{E_2 A_2}\right)}$$

$$\mathbf{a} = \frac{(\mathbf{a}_1 - \mathbf{a}_2) \Delta T \left(\frac{L}{2}\right)}{\frac{t_1 + t_2}{2} + \frac{2(E_1 I_1 + E_2 I_2)}{t_1} \left(\frac{1}{E_1 A_1} + \frac{1}{E_2 A_2}\right)}$$

- Example: 1m x 1m x 0.3m with 0.03 m wall thickness surface plate
  - If not properly annealed, after top is machined and the bottom retains a 0.5 cm layer of white iron:  $\delta = 0.10 \mu\text{m}/\text{C}^\circ$ ,  $\alpha = 0.41 \mu\text{rad}$
  - Similar effects are incurred by steel bearing rails grouted to epoxy granite structures
  - Consider using a symmetrical design (steel on the bottom) to offset this effect
  - Two materials may have similar expansion coefficients, but very different conduction coefficients and density!
  - For a quick estimate of transient effect, assume that the coefficient of expansion of one member is scaled by the ratio of the conduction coefficients

# Thermal Growth Errors: Bimaterial Effect

- Example: Two size 55 linear guides bolted to a granite bed, later used at a different temperature (e.g., in the summer)
- How can these errors be counteracted?
- How can symmetry be used?
- Does segmenting steel reduce the effect?

E20		=
	A	B
1	<b>BiMat.xls</b>	
2	<b>Determine thermal errors in a bi-material beam</b>	
3		
4	<b>Enter numbers in bold</b>	
5		
6	<b>Material properties</b>	
7	Modulus of Elasticity: Eo	<b>1.04E+11</b>
8	Coefficient of thermal expansion: ao	<b>1.10E-05</b>
9	Modulus of Elasticity: Et	<b>1.04E+11</b>
10	Coefficient of thermal expansion: at	<b>9.50E-06</b>
11	<b>Cross section 1 properties</b>	
12	flange thickness (0 for rect. beam): t1	<b>0</b>
13	Height: h1	<b>0.5</b>
14	Width: bo1	<b>1</b>
15	Web thickness (bi=bo for rect. beam): bi1	<b>1</b>
16	Moment of inertia: I1	0.0104
17	Area: Ar1	0.5000
18	<b>Cross section 2 properties</b>	
19	flange thickness (0 for rect. beam): t2	<b>0</b>
20	Height: h2	<b>0.05</b>
21	Width: bo2	<b>0.1</b>
22	Web thickness (bi=bo for rect. beam): bi2	<b>0.1000</b>
23	Moment of inertia: I2	1.04E-06
24	Area: Ar2	0.0050
25		
26	<b>Loading characteristics</b>	
27	Length of beam: L	<b>2</b>
28	Temp. gradient across beam: DT	<b>1.00</b>
29		
30	<b>Results</b>	
31	Max. displacement error (microunits)	0.09
32	Max. slope error	0.17

# Thermal Growth Errors: Thermal Gradient

- One of the most common and insidious thermal errors
  - Beam length = L, height = h, section I, gradient  $\Delta T$ , straightness error:

$$e_T = \frac{y}{r} = \frac{\alpha y \Delta T}{h}$$

$$M = \frac{EI}{r}$$

$$d_T = \frac{M \left( \frac{L}{2} \right)^2}{2EI} = \frac{L^2 \alpha \Delta T}{2h}$$

- Slope error at the ends of the beam ( $\alpha = M(1/2)/EI$ ):

$$q_T = \frac{\alpha \Delta T L}{2h}$$

- For a 1x1x0.3 m cast iron surface plate with  $\Delta T = 1/3 \text{ C}^\circ$  (1  $\text{C}^\circ/\text{m}$ ),  $\delta = 1.5 \text{ }\mu\text{m}$  and  $\theta T = 6.1 \text{ }\mu\text{rad}$ 
  - This is a very conservative estimate, because the plate will diffuse the heat to lessen the gradient
- In a machine tool with coolant on the bed, thermal warping errors can be significant
  - Angular errors are amplified by the height of components attached to the bed

# Thermal Growth Errors: Thermal Gradient

- Causes of gradients
  - The bed may be subjected to a flood of temperature controlled fluid
  - Evaporative cooling (common on large grinders)
  - Room temperature may vary wildly during the day
  - Overhead lights can create gradients in sensitive structures
    - Plastic PVC curtains are extremely effective at reducing infrared heat transmission
  - A large machine on a deep foundation (relies on the concrete for support), can have problems:
    - Several meters under the ground, the concrete is at constant temperature
    - The top of the machine and the concrete are at room temperature
  - Internal heat sources (motors, spindles, ballscrews, process)

# Which Error is it?

- Temperatures of different principle components and locations need to be plotted along side a quality control parameter (e.g., part diameter)
  - In addition, all other functions on the machine should also be plotted
    - E.g., lubricators that squirt oil to bearings every N minutes can cause a sudden temporary expansion of the machine
  - Predictions can be made using fundamental theory or finite element models
    - However, nothing beats real data from a real system
      - The problem lies in interpolating the data
      - Constant adjustment (via SPC) does not address the problem

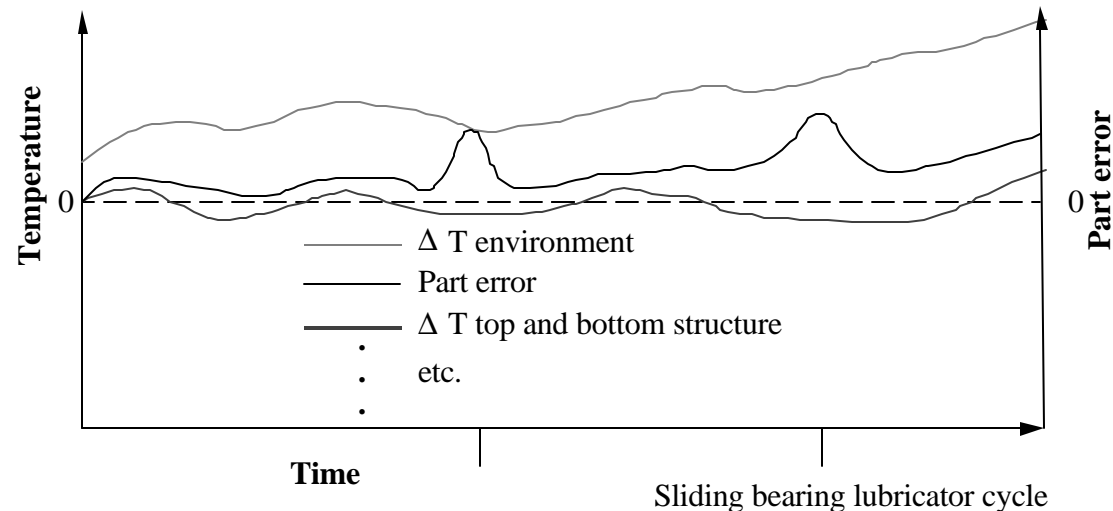



# Modeling Machines and Accounting for Errors with Homogeneous Transformation Matrices

- An HTM is used to model translation and rotation between rigid bodies modeled as coordinate systems
  - Used to predict how an assembly of components behaves as a system
  - The philosophy is VERY useful for thinking about how parts fit together to make robust machines

$$\begin{array}{c|ccc|c}
 X_{N-1} \\
 Y_{N-1} \\
 Z_{N-1} \\
 1
 \end{array}
 =
 \begin{array}{ccc|c}
 O_{ix} & O_{iy} & O_{iz} & P_x \\
 O_{jx} & O_{jy} & O_{jz} & P_y \\
 O_{kx} & O_{ky} & O_{kz} & P_z \\
 0 & 0 & 0 & 1
 \end{array}
 \begin{array}{c}
 X_N \\
 Y_N \\
 Z_N \\
 1
 \end{array}$$

Direction cosines based on Euler angles between Coordinate systems' axes

Translation of CS N's origin along CS N-1's axes

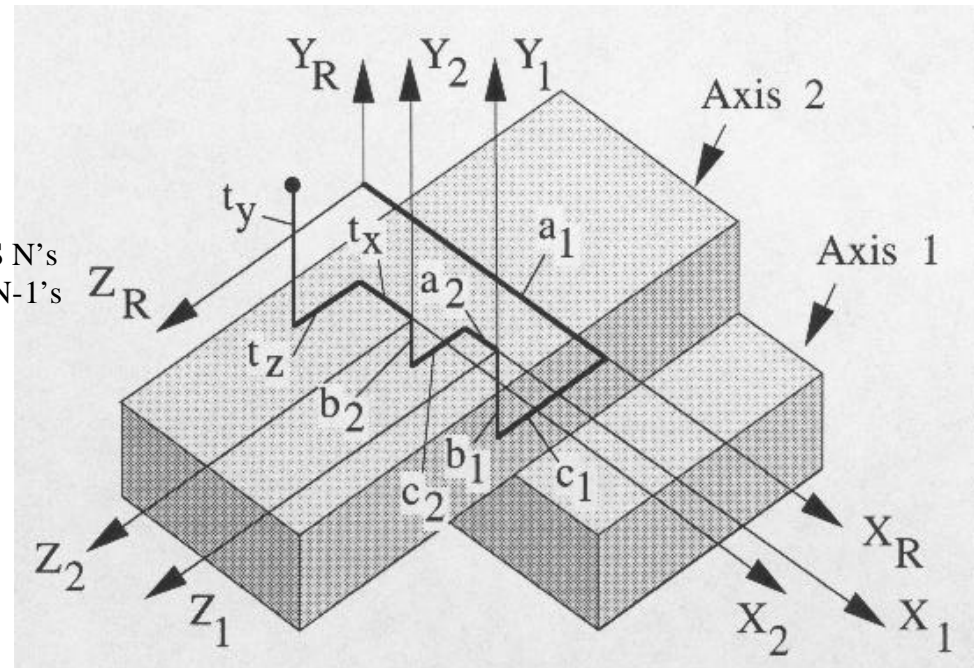
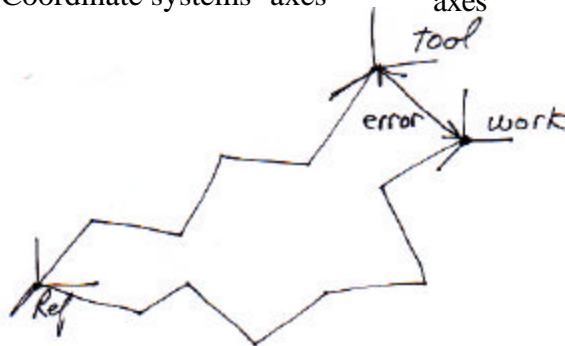

# Error Gain & Budget Spreadsheet to Evaluate Error Sensitivities and Cumulative Errors

A	B	C	D	E	F	G	H	I	J	K	L	M	N	O	P	Q		
1	<b>Error Gain Spreadsheet</b>																	
2	Written by Alex Slocum, John Moore, Whit Rappole October 4, 1999																	
3	Last Modified Oct 4, 1999																	
4																		
5	Enter numbers in BOLD    Output is in RED																	
6	Number, N, of coordinate systems (not including the reference system) MAXIMUM OF 15																	
7	15																	
8	The HTMs revert to identity matrices for coordinate systems beyond N, so do not need to delete entries where CS says "Not Used"																	
9																		
10	Start with axis at the tool tip, and work back to the reference frame																	
11	Enter coordinates: displacements in the N-1 coordinate system to get to the origin of the current Nth coordinate system																	
12																		
13	CS #	Description				Errors for this axis on/off												
14	15	Tool tip				on												
15		Actual	Geometric Errors		Thermal	Deformation	Error Gains						Net Errors in the current CS			Net Errors		
16	Axes	dimensions	Random	Systematic	Errors	Errors	GX	GY	GZ	G#X	G#Y	G#Z	Sum	RMS	Expected	in the reference CS		
17	X	1	0.0062	0.0056	0.0002	0.0066	1	0	0	0	0	0	0.0186	0.0138	0.0162	$\delta X =$	0.0162	
18	Y	2	0.0097	0.0013	0.0058	0.0038	0	1	0	0	0	0	0.0206	0.0146	0.0176	$\delta Y =$	0.0176	
19	Z	3	0.0060	0.0028	0.0096	0.0019	0	0	1	0	0	0	0.0203	0.0155	0.0179	$\delta Z =$	0.0179	
20	$\theta X$ (rad)	0	0.0040	0.0030	0.0077	0.0020	0	0	0	1	0	0	0.0168	0.0134	0.0151	$\epsilon X$ (rad) =	0.0151	
21	$\theta Y$ (rad)	0	0.0090	0.0097	0.0058	0.0026	0	0	0	0	1	0	0.0270	0.0201	0.0236	$\epsilon Y$ (rad) =	0.0236	
22	$\theta Z$ (rad)	0	0.0093	0.0009	0.0075	0.0067	0	0	0	0	0	1	0.0244	0.0177	0.0211	$\epsilon Z$ (rad) =	0.0211	
23																		
24	CS #	Description				Errors for this axis on/off												
25	14	Tool holder				off												
26		Actual	Geometric Errors		Thermal	Deformation	Error Gains						Net Errors in the current CS			Net Errors		
27	Axes	dimensions	Random	Systematic	Errors	Errors	GX	GY	GZ	G#X	G#Y	G#Z	Sum	RMS	Expected	in the reference CS		
28	X	1	0.0095	0.0093	0.0025	0.0072	1	0	0	0	0	0	0.0286	0.0213	0.0000	$\delta X =$	0.0000	
29	Y	2	0.0015	0.0045	0.0093	0.0090	0	1	0	0	0	0	0.0243	0.0229	0.0000	$\delta Y =$	0.0000	
30	Z	3	0.0009	0.0034	0.0015	0.0033	0	0	1	0	0	0	0.0091	0.0082	0.0000	$\delta Z =$	0.0000	
31	$\theta X$ (rad)	0	0.0087	0.0023	0.0047	0.0006	0	-3.001	1.9985	1	0	0	0.0163	0.0115	0.0000	$\epsilon X$ (rad) =	0.0000	
32	$\theta Y$ (rad)	0	0.0011	0.0075	0.0049	0.0068	2.9995	0	-1.001	0	1	0	0.0203	0.0193	0.0000	$\epsilon Y$ (rad) =	0.0000	
33	$\theta Z$ (rad)	0	0.0099	0.0069	0.0091	0.0059	-2	0.999	0	0	0	1	0.0319	0.0241	0.0000	$\epsilon Z$ (rad) =	0.0000	

# Making Modeling (Designing) Easier with Exact Constraint Design

- Exact Constraint Design: The number of points of constraint should be equal to the number of degrees of freedom to be constrained.
  - BUT, how can you support a plate at multiple points yet not get the “four legged chair with one short leg” syndrome?
  - BUT, How do windshield wiper blades work?
- The key is to use ECD as a guideline, a catalyst for synthesis, but never as an absolute!
  - Exact constraint design often creates contacts at single points, and high stresses if one is not careful!

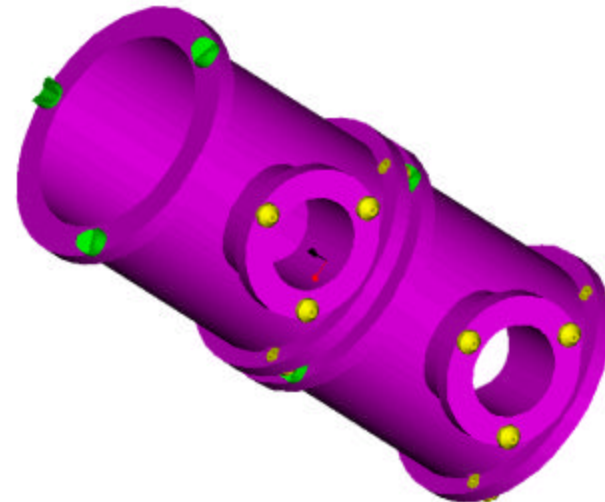
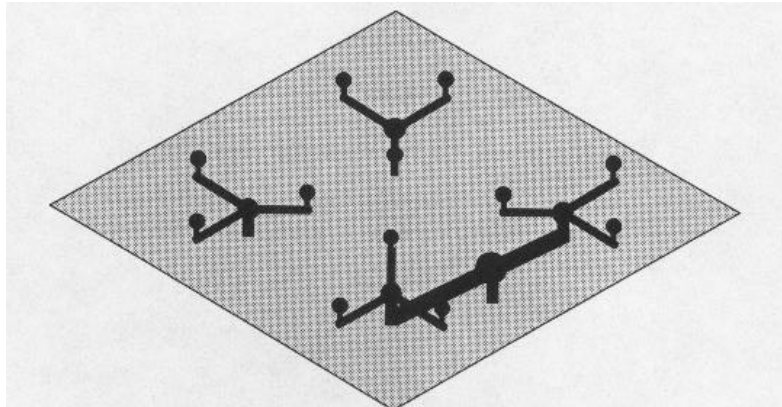

# Making Modeling (Designing) Easier with Elastic Averaging

- Any one error can be averaged out by having many similar features
  - As in gathering data with random errors, the accuracy of the reading is proportional to the square root of the number of samples taken

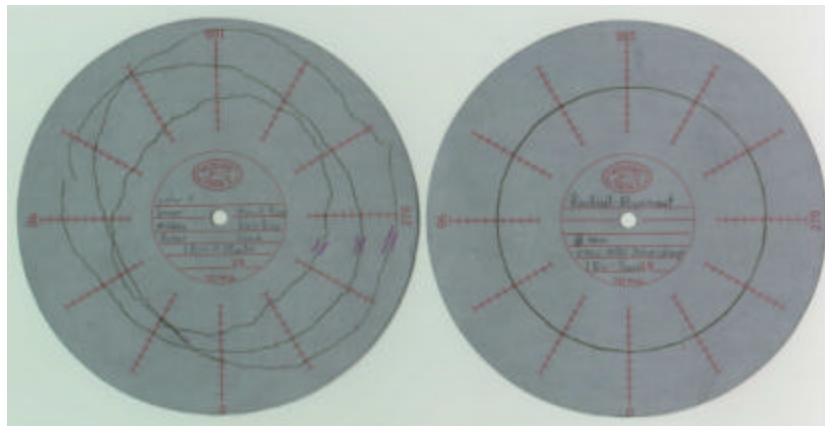
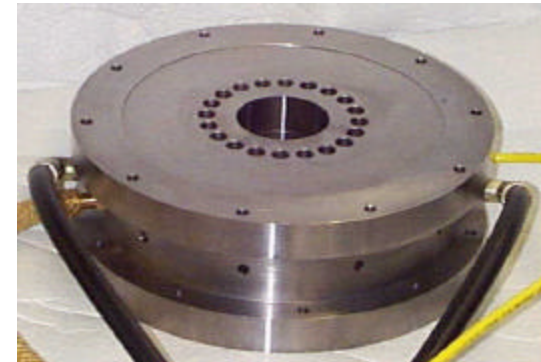
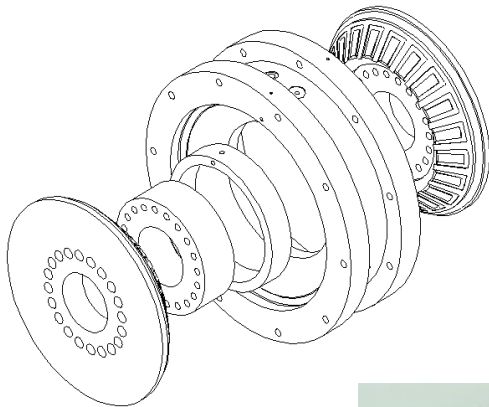

## Example: Elastically Averaged Design

- A “curvic” coupling is essentially two face gears that are forced together, and small errors are averaged out by elastic deformation of the teeth
  - This is one of the most common indexing methods used in precision machine tools

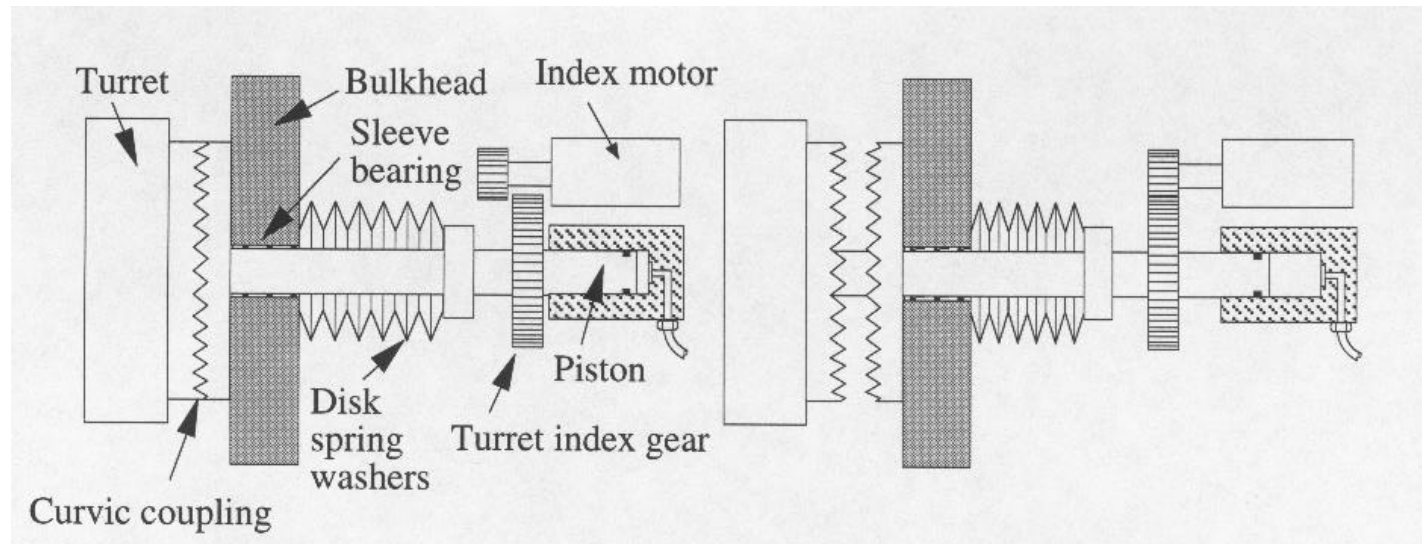

# Overconstraint is NOT Elastic Averaging

- Example: Often one component wants to move along one path and another along another, but they are attached to each other
  - Thus they will fight each other, and high forces can result which accelerates wear
  - Either more accurate components and assembly is required, or compliance, or clearance (pin in oversized hole) must be provided between the parts
- Designers should always be thinking of not just an instant along motion path, but along the entire motion path

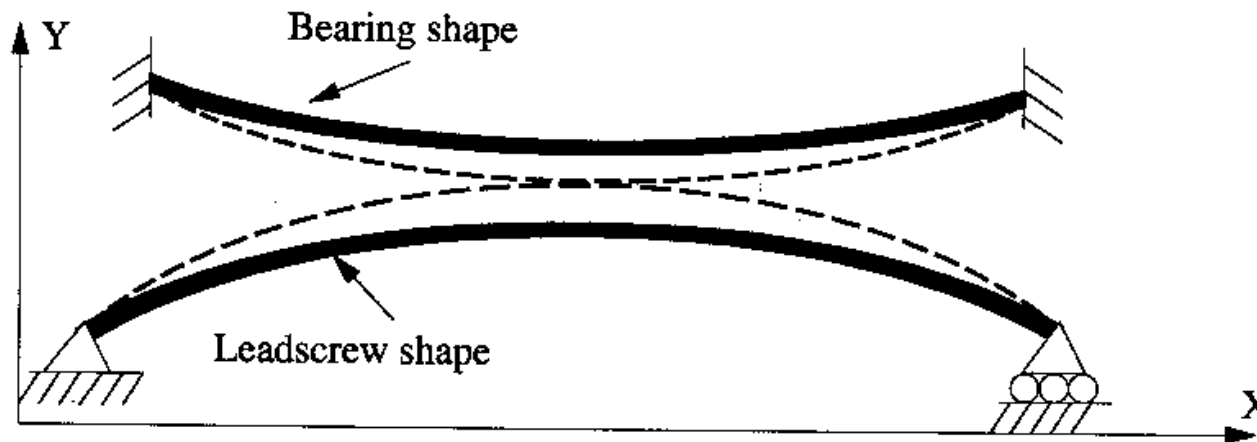

## The Moral of the Story is...

- To be robust and well-engineered, systems **MUST** be subject to a sensitivity analysis:
  - Accuracy and repeatability of motion
  - Constraint
  - Effects of variations on stress, deflection.....