

8. Remove from the upper body the inlet and outlet valves by prising them out with a screwdriver blade.

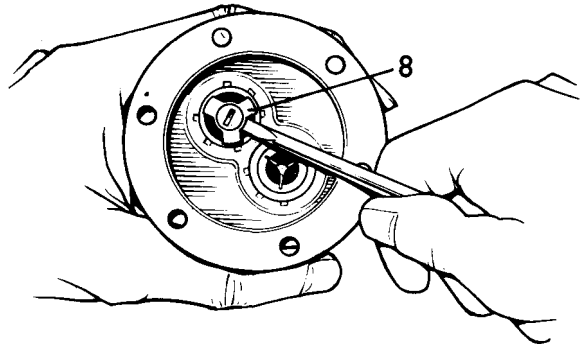

## Examination

9. Clean all components in petrol and examine for wear and deterioration.
10. Check in particular the rocker and renew if wear is evident also the diaphragm and spring.
11. Check the upper and lower body mating faces for distortion and the engine mating face.

**NOTE:** Repair kits are available for this pump and it is advisable to fit all the new components supplied in the kit.

## Re-assembling

12. Place a new washer in the base of each valve bore and fit the valves in the upper body by pressing them into the casting with a suitable tool (a piece of steel tubing 9/16 in (14.28 mm) inside diameter and 3/4 in (19.05 mm) outside diameter). Ensure that the valves are positioned correctly.
  - a. Pump inlet valve pressed in with the concave side leading.
  - b. Pump outlet to engine valve pressed in with the raised side leading.
13. Stake the casing round each valve in six places with a suitable punch.
14. Reverse instructions 1 to 7.

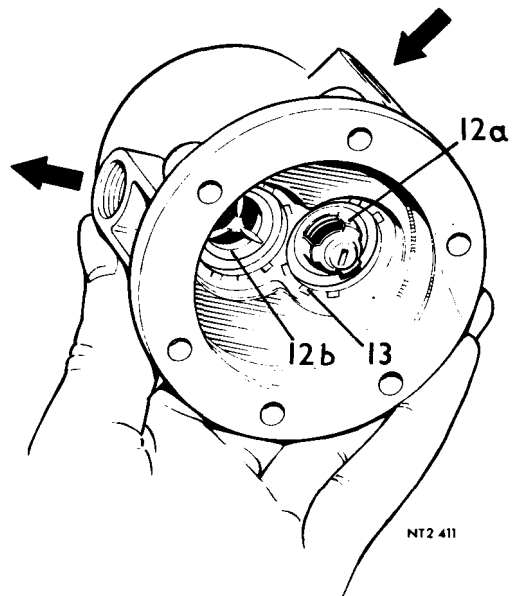

**FUEL TANK**

– Remove and refit

19.55.01

**Removing**

1. Drain the fuel tank 19.55.02 instructions 1 and 2.
2. Remove the filler to tank hose 19.40.19.
3. Disconnect the fuel tank gauge unit leads.
4. Remove the six bolts complete with plain and spring washers securing the fuel tank to the body.
5. Withdraw the fuel tank and disconnect the evaporative emission control pipes.

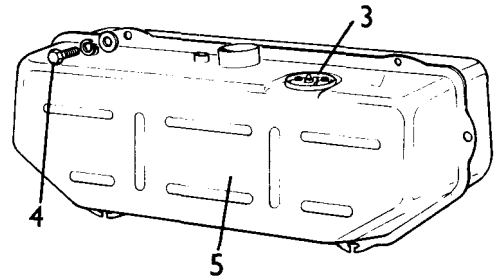

**Refitting**

6. Reverse instructions 1 to 5.

**FUEL TANK**

– Drain

19.55.02

**WARNING:** Extinguish all naked lights.

1. Place the car on a ramp or over a pit.
2. Disconnect the rubber connection hose from the main line pipe and allow the fuel to drain into a suitable clean receptacle.
3. Reconnect the hose to the main line pipe.

**CAUTION:** If the fuel is to be returned to the tank, ensure that absolute cleanliness is observed during draining and storage. Foreign matter or fluids in the fuel may cause damage or faults in the fuel system.

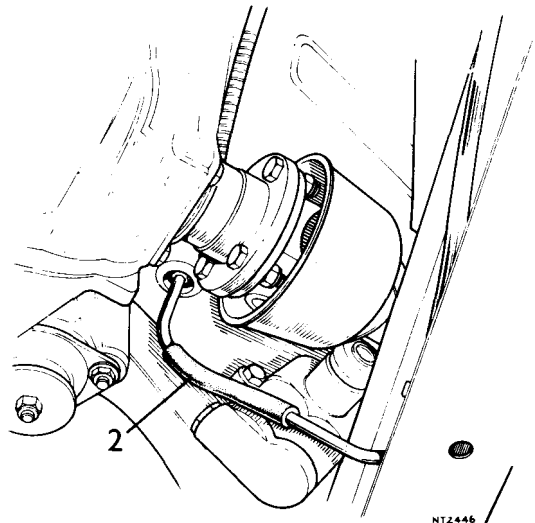

NT2446

**FUEL FILLER CAP**

– Remove and refit

19.55.08

**Removing**

1. Remove the rear compartment trim panel 76.13.20.
2. Working from the rear compartment slacken the hose clip securing the filler cap extension to the filler hose.
3. Withdraw the filler cap complete assembly.
4. Remove the rubber sealing ring.

**Refitting**

5. Assemble the rubber sealing ring to the filler cap extension.
6. Fit the assembly to the body ensuring, that the filler cap extension locates properly in the filler hose.
7. Secure the hose to the filler cap with the hose clip.
8. Refit the rear compartment trim panel 76.13.20.

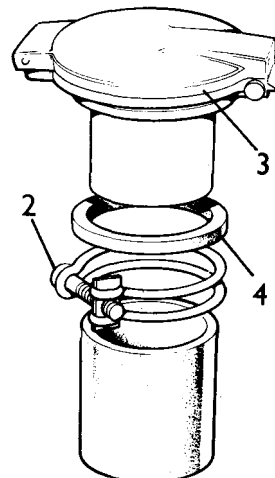

NT2 706



**COOLING SYSTEM OPERATIONS**

Coolant -- drain and refill . . . . .	26.10.01
Cooling system -- pressure test . . . . .	26.10.07
Fan -- remove and refit . . . . .	26.25.06
Hoses -- remove and refit	
-- heater to water pump . . . . .	26.30.18
-- heater valve to heater . . . . .	26.30.40
-- manifold to water pipe . . . . .	26.30.17
-- radiator -- top . . . . .	26.30.01
-- radiator -- bottom . . . . .	26.30.07
-- water pump housing to manifold . . . . .	26.30.46
Overflow pipe -- remove and refit . . . . .	26.30.01
Radiator -- remove and refit . . . . .	26.40.01
Thermostat	
-- remove and refit . . . . .	26.45.01
-- test . . . . .	26.45.09
Water pump	
-- belt -- remove and refit . . . . .	26.20.07
-- belt tension -- check and adjust . . . . .	26.20.01
-- housing -- remove and refit . . . . .	26.50.03
-- remove and refit . . . . .	26.50.01



COOLANT

– Drain and refill

26.10.01

Drain

1. Set heater controls to HOT.
2. Remove the radiator cap. **CAUTION** If the engine is hot exercise care. Turn the cap slowly and release any pressure in the system before removing the cap.
3. Disconnect the radiator bottom hose at the radiator.
4. Remove the drain plug on the rear, right hand side of the cylinder block.
5. When system has drained, fit and tighten the drain plug and reconnect the radiator bottom hose.

Refill

6. Fill the cooling system with clean soft water and, if required, anti-freeze.
7. Fit the radiator cap and run the engine at a fast idle for approximately 1 to 2 minutes.
8. Remove the radiator cap and top up as necessary.
9. Replace the radiator cap and check the system for leaks.
10. Top up the overflow bottle to the half full level.

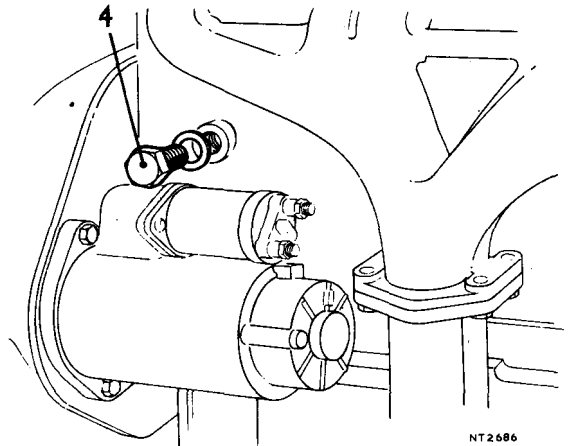

COOLING SYSTEM

– Pressure Test

26.10.07

Radiator cap

1. Rinse the radiator filler cap in clean water and while it is still wet fit the cap to the pressure tester.
2. Pump up pressure until the gauge pointer ceases to rise. Reject the filler cap if the gauge does not register and maintain a pressure of 1 lb/in<sup>2</sup> (0.06 kg/cm<sup>2</sup>) below the figure stamped on the filler cap for a period of at least ten seconds without further pumping.

Radiator

3. Warm the engine.
4. Remove the radiator filler cap and top up the system if required.
5. Fit the pressure tester to the radiator.
6. Pump up pressure to the figure stamped on the filler cap, and check that this pressure can be maintained for approximately ten seconds without further pumping.
7. Check for leaks while system is pressurised. A pressure drop within ten seconds and no external leaks is indicative of internal leakage.

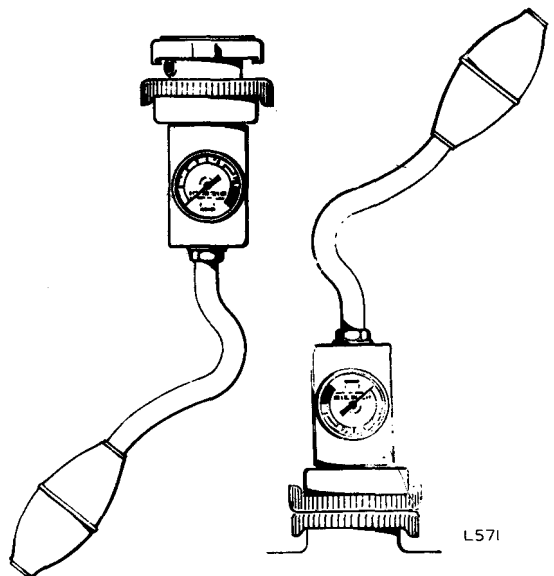

# COOLING SYSTEM

## WATER PUMP BELT TENSION

– Check and adjust

26.20.01

### Checking

1. Check that the belt is capable of approximately  $\frac{3}{4}$  to 1 in (19.1 to 25.4 mm) deflection at the mid-point of its longest run.

### Adjusting

2. Slacken the alternator pivot bolt nut and the adjustment bracket bolt.
3. Pivot the alternator to obtain belt deflection as instruction 1.
4. Tighten the alternator pivot bolt nut and the adjustment bracket bolt.

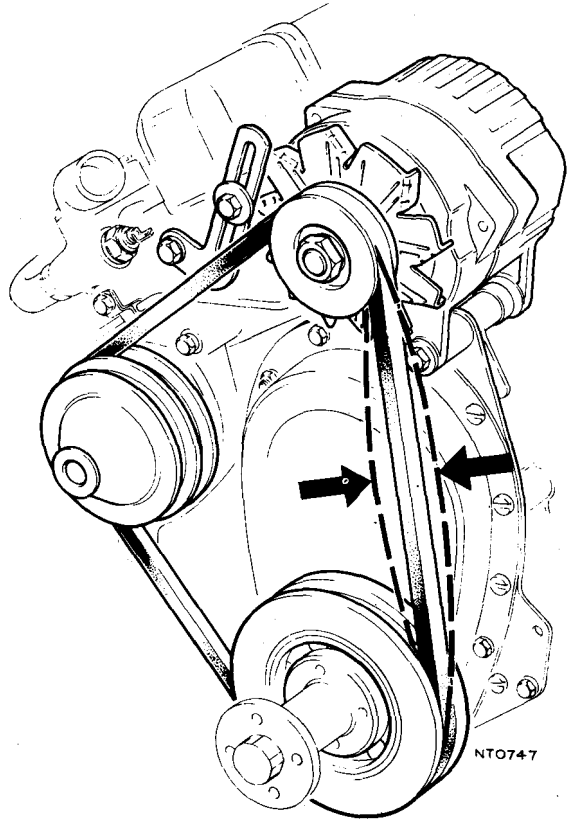

## WATER PUMP BELT

– Remove and refit

26.20.07

### Removing

1. Slacken the alternator pivot and nut.
2. Slacken the adjustment bracket bolts.
3. Pivot the alternator towards the engine.
4. Release the belt from the alternator, water pump, and crankshaft pulley.
5. Remove the belt.

### Refitting

6. Reverse instructions 1 to 5.

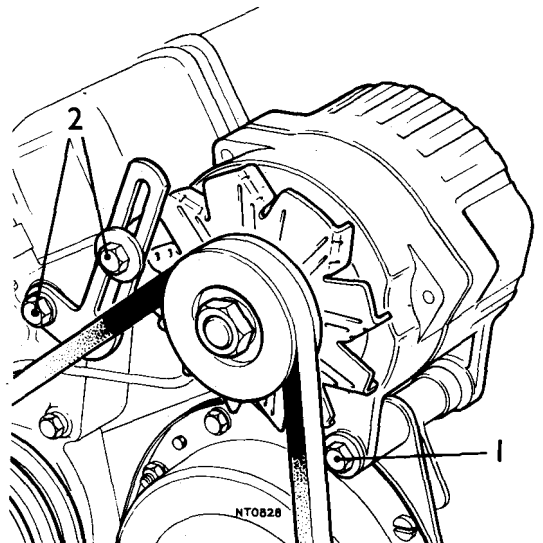

**FAN (Carburettor engines)**

– Remove and refit 26.25.06

**Removing**

1. Remove the radiator 26.40.01.
2. Straighten the lock tabs of the fan securing bolts.
3. Remove the lockplates, four bolts and washers securing the fan to the crankshaft extension and withdraw the fan complete with bushes.

**Refitting**

4. Ensure that the mounting bushes and spacers are fitted and in sound condition.
5. Offer up the fan to the crankshaft extension and align the mounting holes. Note that the recessed faces of the fan hub must be fitted adjacent to the radiator.
6. Fit the four securing bolts and washers. Evenly tighten the bolts and bend over lock tabs.
7. Fit the radiator 26.40.01

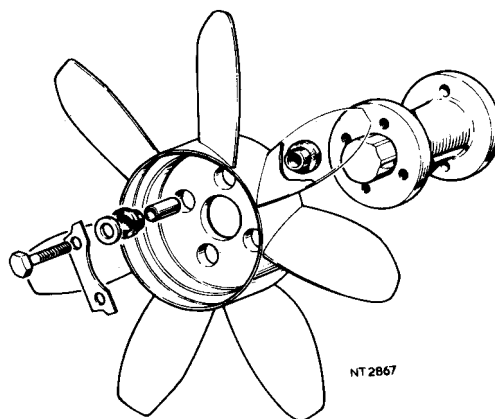

**FAN (P.I. Engines)**

– Remove and refit 26.25.06

**Removing**

1. Remove the radiator 26.40.01.
- 2a. **To remove the fan only** remove the outer four bolts and washers securing the fan to the fan adaptor, and withdraw the fan.
- 2b. **To remove fan and adaptor** remove the inner four bolts and washers securing the fan adaptor to the crankshaft extension.

**Refitting**

**Fan only**

- 3a. Offer up the fan to the adaptor ensuring that the face marked **FRONT** is fitted adjacent to the radiator.
- 4a. Align the mounting holes and fit the four securing bolts and washers. Evenly tighten the bolts.
- 5a. Fit the radiator 26.40.01. and refill the cooling system.

**Fan complete with adaptor**

- 3b. Offer up the fan and adaptor to the crankshaft extension and align the mounting holes.
- 4b. Fit the four securing bolts and washers. Evenly tighten the bolts.
- 5b. Fit the radiator 26.40.01 and refill the cooling system.

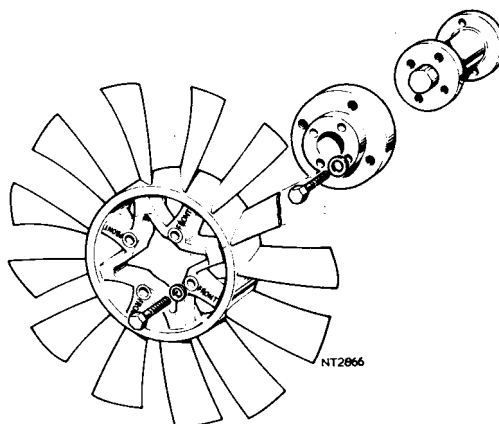

## COOLING SYSTEM

---

### HOSES

– Remove and refit

– Radiator – top	26.30.01
– Radiator – bottom	26.30.07
– Manifold to water pump pipe	26.30.17
– Heater to water pump	26.30.18
– Heater valve to heater	26.30.40
– Water pump housing to manifold	26.30.46

### Removing

1. Drain the cooling system.
2. Slacken the hose clips.
3. Remove the hose.

### Refitting

4. Reverse instructions 1 to 3.

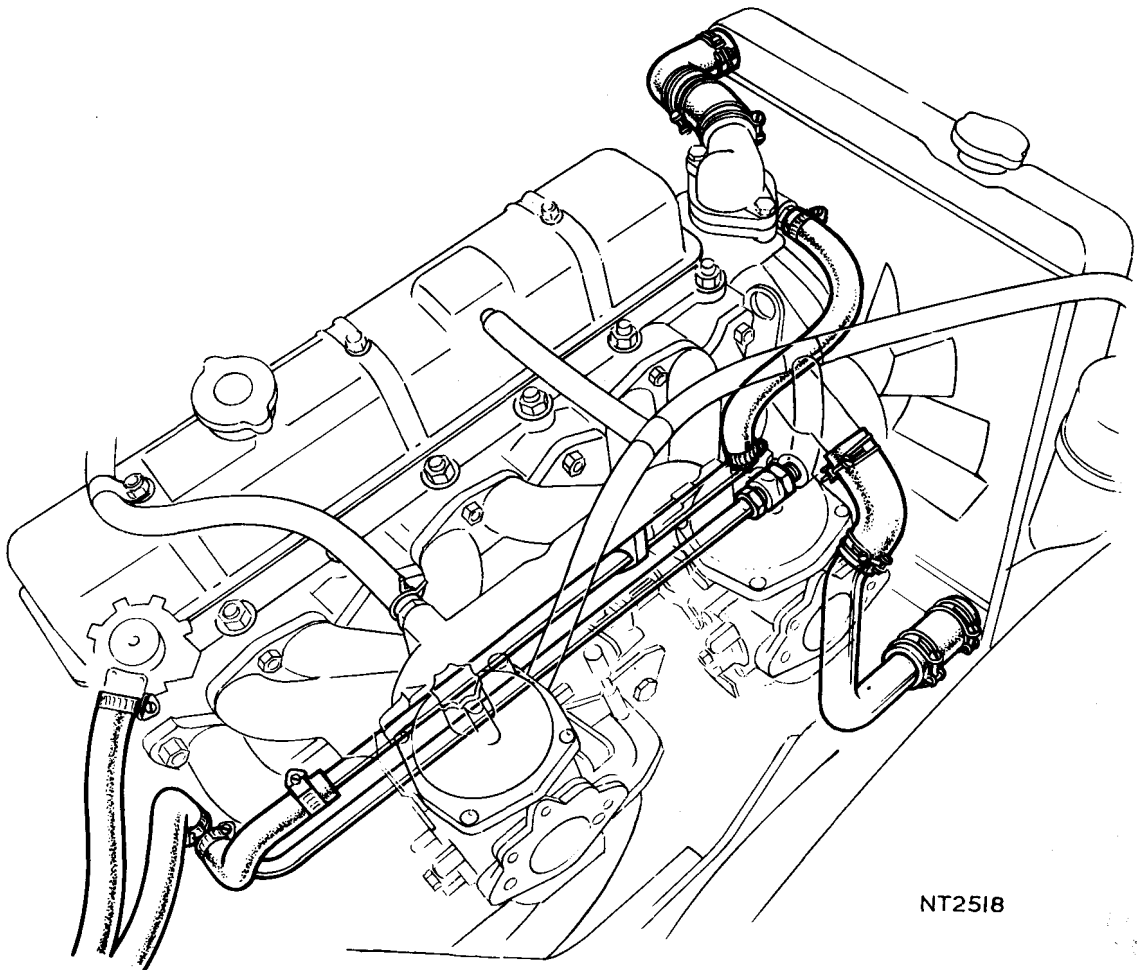

NT2518

## OVERFLOW PIPE

– Remove and refit

26.30.31

### Removing

1. Detach the overflow pipe from the radiator.
2. Withdraw the overflow pipe from the filler cap of the overflow bottle.

### Refitting

3. Reverse instructions 1 and 2. Ensure that the bottle end of the tube reaches to approximately 3/8 in (9.5 mm) of the bottom of the bottle.

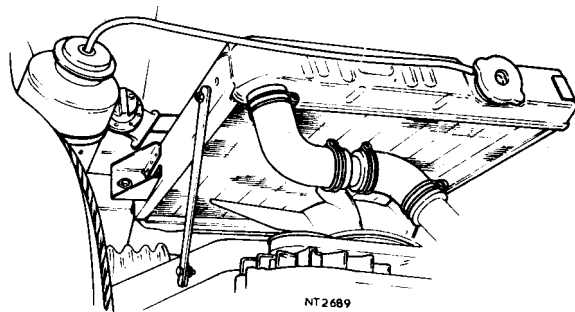

## RADIATOR

– Remove and refit

26.40.01

### Removing

1. Drain the cooling system.
2. Disconnect the top hose at the radiator.
3. Slacken the two bolts and nuts securing the lower end of the radiator stays to the tubular cross member.
4. Remove the two nuts and spring washers securing the upper end of the radiator stays to the radiator.
5. Detach the stays from the radiator.
6. Remove the two bolts and washers (earlier cars) or two nuts and washers (later cars) securing the radiator to the car. \*\*
7. Withdraw the radiator and the two packing pieces.

### Refitting

8. Locate the radiator in position on the car and fit the two packing pieces below the radiator mounting brackets. Fit the two mounting bolts and washers.
9. Reverse instructions 1 to 5.

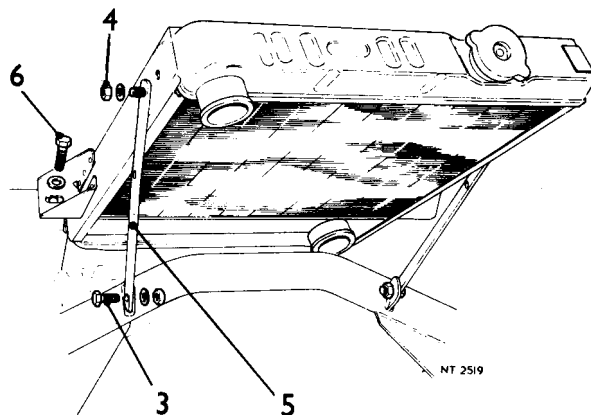



## COOLING SYSTEM

### THERMOSTAT

– Remove and refit

26.45.01

#### Removing

1. Drain the cooling system.
2. Remove the two bolts and spring washers securing the thermostat elbow to the water pump housing and withdraw the thermostat elbow.
3. Withdraw the thermostat.

#### Refitting

4. Clean the mating faces of the thermostat elbow and water pump housing.
5. Insert the thermostat in the water pump housing.
6. Fit a new gasket and the thermostat elbow. Tighten the two securing bolts.
7. Fill the cooling system.

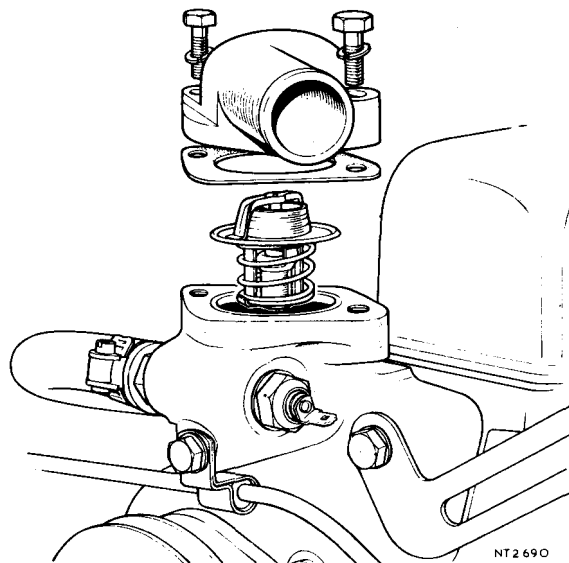

### THERMOSTAT

– Test

26.45.09

1. Determine the opening temperature of the thermostat stamped on the flange or base.
2. Immerse the thermostat in water heated to the opening temperature of the thermostat. Renew the thermostat if it fails to open.

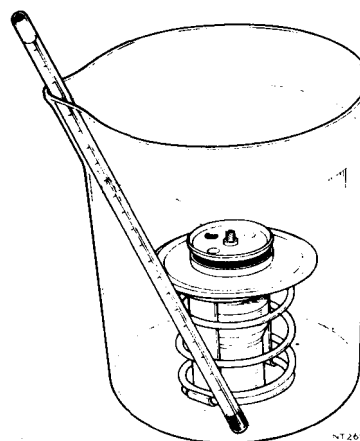

## WATER PUMP

– Remove and refit

26.50.01

## Removing

1. Drain the cooling system.
2. Slacken the alternator mounting bolts, release the tension from the water pump/alternator drive belt, and slip the belt from the water pump pulley.
3. Remove the three nuts and spring washers securing the water pump mounting flange to the water pump body.
4. Withdraw the water pump.

## Refitting

5. Clean the water pump mounting faces and fit a new gasket.
6. Reverse instructions 1 to 3.

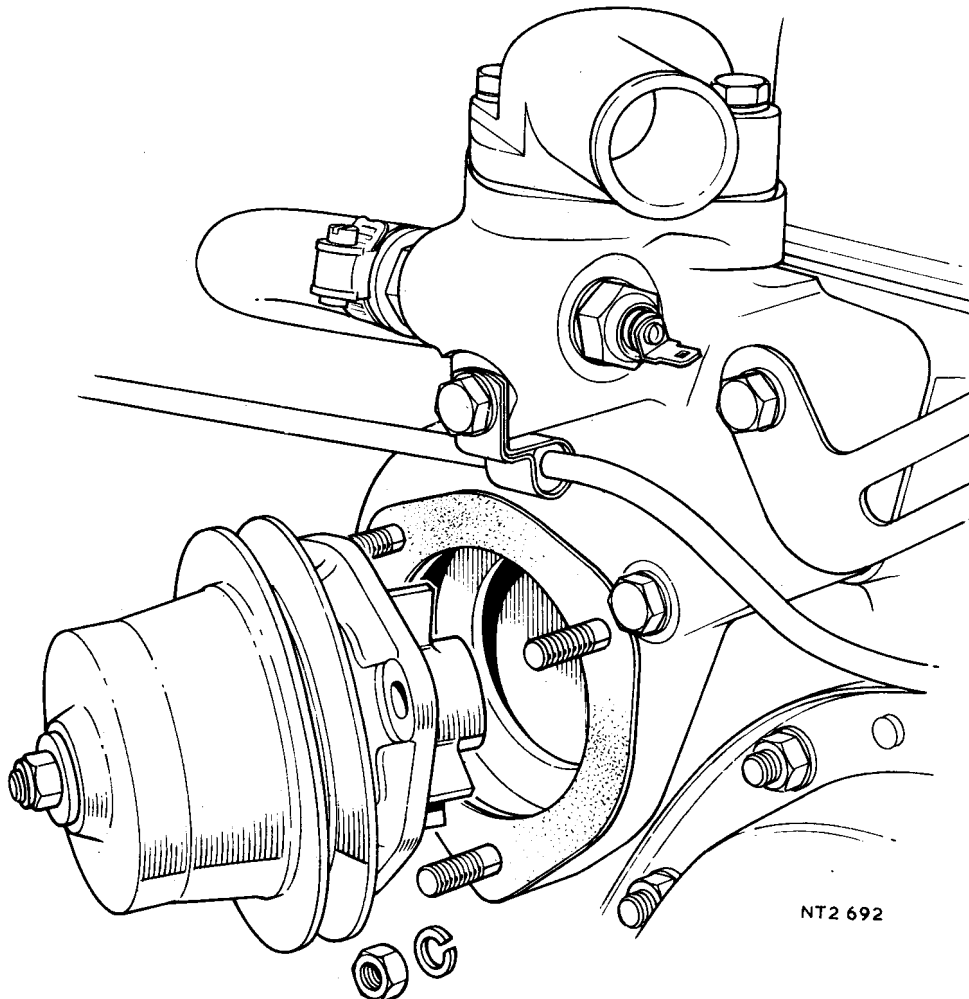

# COOLING SYSTEM

## WATER PUMP HOUSING

– Remove and refit

26.50.03

### Removing

1. Drain the cooling system.
2. Disconnect the radiator top hose from the thermostat elbow.
3. Disconnect the bottom hose from the water pump housing.
4. Slacken the alternator mounting bolts, release tension from the water pump/alternator drive belt and slip the belt from the water pump pulley.
5. Disconnect the spade terminal from the temperature transmitter.
6. Remove the two bolts and spring washers securing the thermostat elbow to the water pump housing and withdraw the elbow and thermostat.
7. Disconnect the water pipe union at the rear of the water pump housing.
8. Remove the three bolts and spring washers securing the water pump housing to the cylinder head. The top right hand bolt also secures the alternator adjusting bracket. Note that the three bolts are of different lengths. Observe locations.
9. Withdraw the water pump housing.
10. Remove the water pump and temperature transmitter if required.

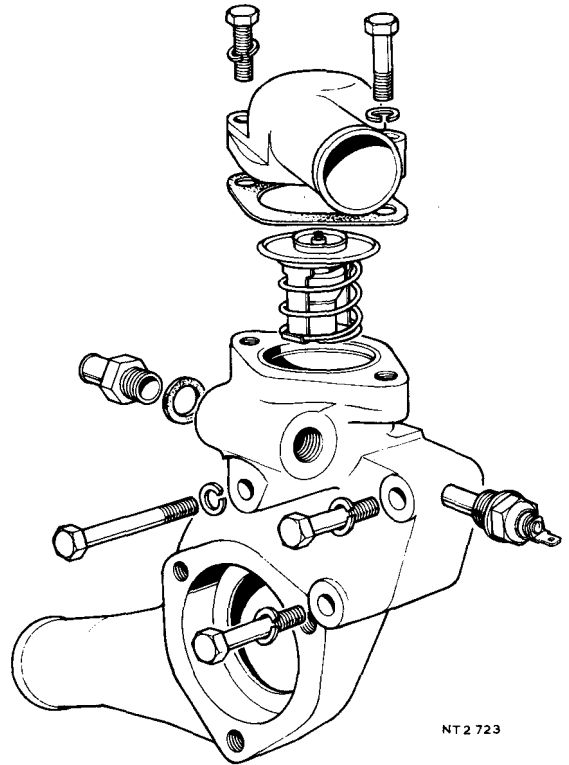

NT 2 723

### Refitting

11. Fit the water pump and temperature transmitter (if removed).
12. Ensure the mating faces of cylinder head and water pump housing are clean.
13. Using a new gasket offer the water pump housing to the cylinder head and engage the three securing bolts and spring washers. The alternator adjusting bracket is fitted to the top right hand bolt.
14. Fit the water pipe union to the water pump housing and tighten the housing securing bolts.
15. Reverse instructions 1 to 6.

**MANIFOLD AND EXHAUST SYSTEM OPERATIONS**

Down pipe flange packing – remove and refit . . . . .	30.10.26
Exhaust manifold – remove and refit . . . . .	30.15.01
Exhaust system . . . . .	30.00.00 **
Exhaust system complete – remove and refit . . . . .	30.10.01
Front pipes – remove and refit . . . . .	30.10.09
Induction manifold – remove and refit . . . . .	30.15.02
	** 30.15.03
	30.15.04 **
Intermediate pipes	
– front – L.H. – remove and refit . . . . .	30.10.11
– front – R.H. – remove and refit . . . . .	30.10.12
– rear – L.H. – remove and refit . . . . .	30.10.24
– rear – R.H. – remove and refit . . . . .	30.10.25
Manifold gasket – remove and refit . . . . .	30.15.15
Silencer assembly – remove and refit . . . . .	30.10.14



## EXHAUST SYSTEM

30.00.00

\*\* On earlier carburettor engined cars the exhaust system differs from that shown in this Section in that it has a single exhaust pipe up to the silencer at the rear. \*\*

### EXHAUST SYSTEM COMPLETE

– Remove and refit

30.10.01

#### Removing

1. Slacken the two clips securing the front intermediate pipes to the rear intermediate pipes.
2. Remove the nut, bolt and clamp plate securing the tail pipes to the flexible mounting.
3. Remove the two nuts and washers from the clips securing the silencer assembly to the rear intermediate pipes and mounting bracket.
4. Remove the silencer assembly and rear intermediate pipes.

5. Remove the four nuts and lockwashers securing the front pipes to the manifold.
6. Remove the nut, bolt and lock washer securing the front intermediate pipes to the mounting bracket.
7. Remove the front pipes and front intermediate pipes.

#### Refitting

8. Fit new flange packing.
9. Reverse instructions 1 to 7, ensuring gas proof joints at all pipe connections.

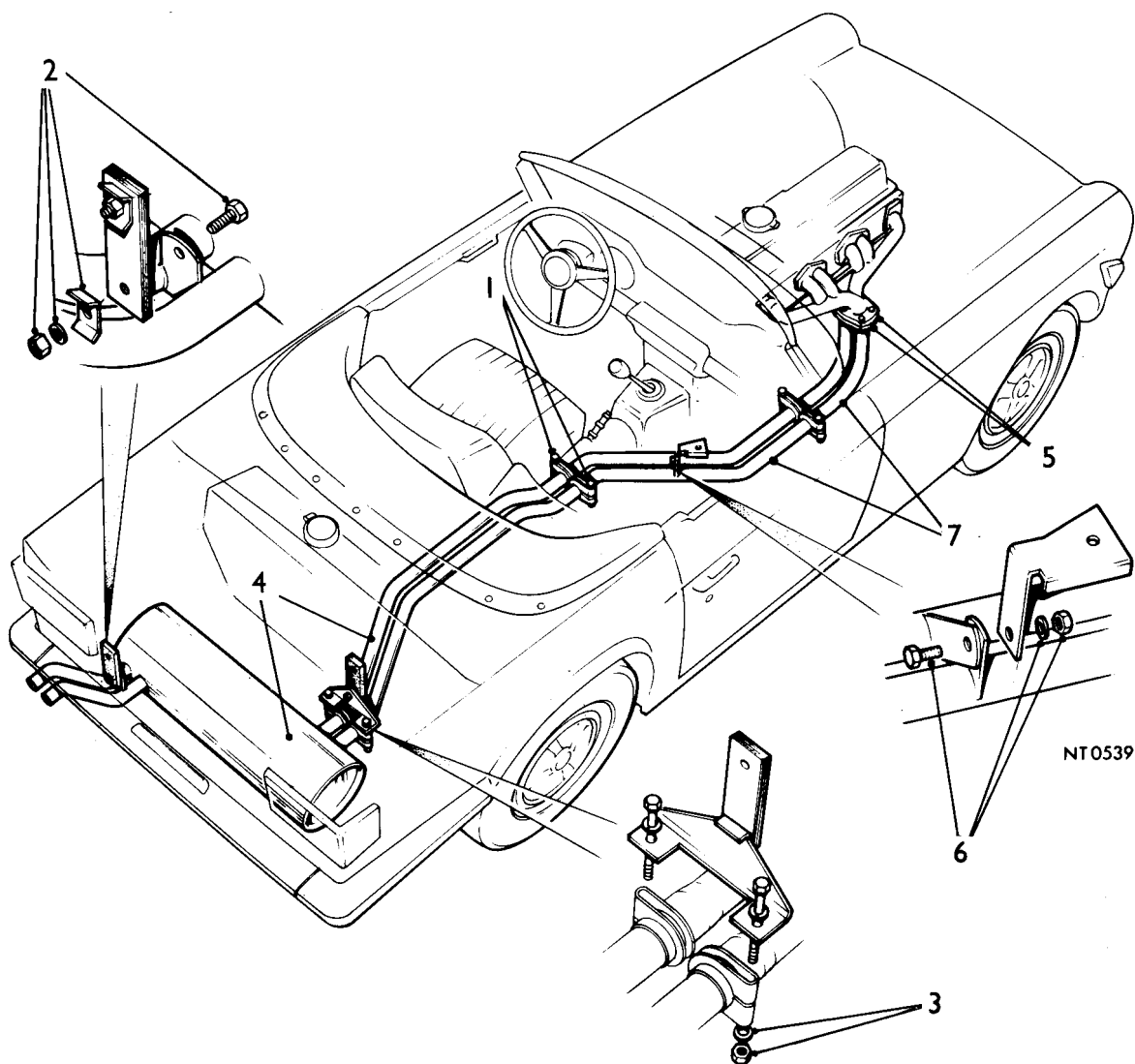

# MANIFOLD AND EXHAUST SYSTEM

## FRONT PIPES

– Remove and refit 30.10.09

### Removing

1. Remove the front intermediate pipes 30.10.11/30.10.12.
2. Remove the four nuts and lockwashers securing the front pipes to the manifold.
3. Remove the front pipes.

### Refitting

4. Refit the front intermediate pipes but do not fully tighten the clips.
5. Slide the front pipes into the intermediate pipes sufficiently to ensure gas proof joints.
6. Fit the new flange packing.
7. Align the front pipes over the manifold studs and replace and tighten the nuts and lockwashers.
8. Tighten all clips, and fixings.

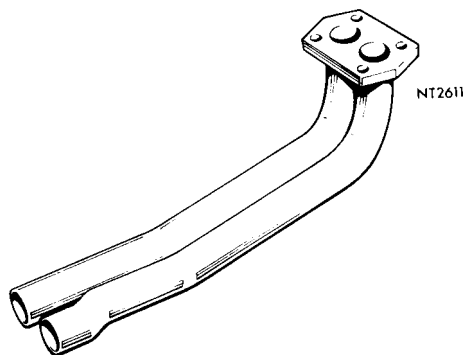

## INTERMEDIATE PIPES – FRONT

– Remove and refit – L.H. 30.10.11

– R.H. 30.10.12

### Removing

1. Slacken the two clips securing the front intermediate pipes to the rear intermediate pipes.
2. Slacken the two clips securing the front pipes to the front intermediate pipes.
3. Remove the nut, bolt and lockwasher securing the front intermediate pipes to the mounting bracket.
4. Disengage the rear intermediate pipes from the front intermediate pipes.
5. Remove the front intermediate pipes.

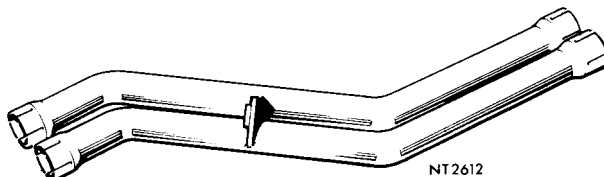

### Refitting

6. Reverse instructions 1 to 5 ensuring gas proof joints at all pipe connections.

**SILENCER ASSEMBLY**

– Remove and refit 30.10.14

**Removing**

1. Remove the nut, bolt and clamp plate securing the tail pipes to the flexible mounting.
2. Slacken the two clips securing the silencer assembly to the rear intermediate pipes and mounting bracket.
3. Remove the silencer assembly.

**Refitting**

4. Reverse instructions 1 to 3, ensuring gas proof joints at the pipe connections.

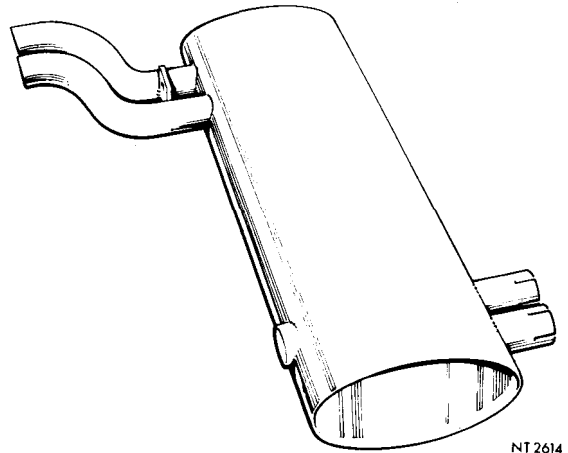

NT 2614

**INTERMEDIATE PIPES – REAR**

– Remove and refit – L.H. 30.10.24

– R.H. 30.10.25

**Removing**

1. Slacken the two clips securing the silencer assembly to the rear intermediate pipes and mounting bracket.
2. Slacken the two clips securing the front intermediate pipes to the rear intermediate pipes.
3. Disengage the silencer assembly from the rear intermediate pipes.
4. Remove the rear intermediate pipes.

**Refitting**

5. Reverse instructions 1 to 4, ensuring gas proof joints at all pipe connections.

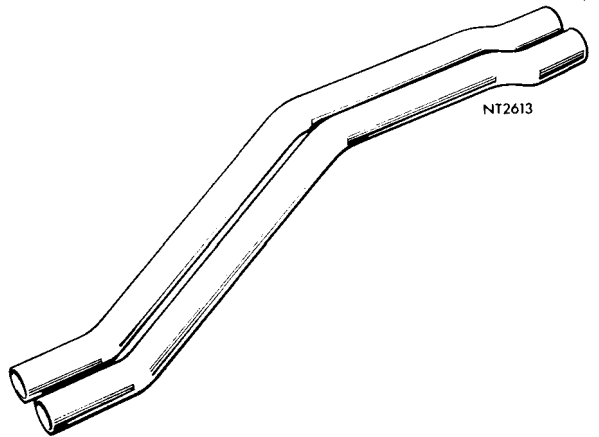

NT 2613

**DOWN PIPE FLANGE PACKING**

– Remove and refit 30.10.26

**Removing**

1. Remove the nut and bolt securing the front intermediate pipes to the support bracket.
2. Remove the four nuts and lockwashers securing the front pipes to the manifold.
3. Pull down the pipes and remove the flange packing.

**Refitting**

4. Fit new flange packing.
5. Reverse instructions 1 and 2, ensuring that the stud nuts are tightened to 20 to 25 lbf ft (2.8 to 3.5 kgf m).

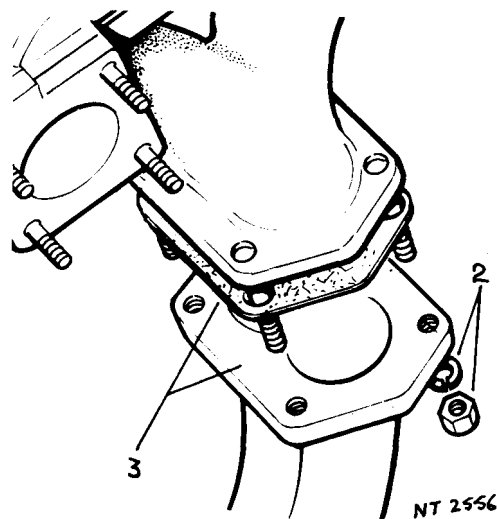

NT 2556

# MANIFOLD AND EXHAUST SYSTEM

## EXHAUST MANIFOLD

– Remove and refit 30.15.01

### Removing

1. Remove the nut and bolt securing the front intermediate pipes to the support bracket.
2. Remove the four nuts and lockwashers securing the front pipes to the manifold.
3. Pull down the pipes and remove the flange packing.
4. Remove the induction manifolds 30.15.02.
5. Remove the four nuts and lockwashers securing the exhaust manifold to the cylinder head.
6. Pull the manifold clear of the studs and remove it from the engine.

### Refitting

7. Renew the flange packing.
8. Reverse instructions 1 to 6, ensuring that all stud nuts are tightened to 20 to 25 lbf ft. (2.8 to 3.5 kgf m).

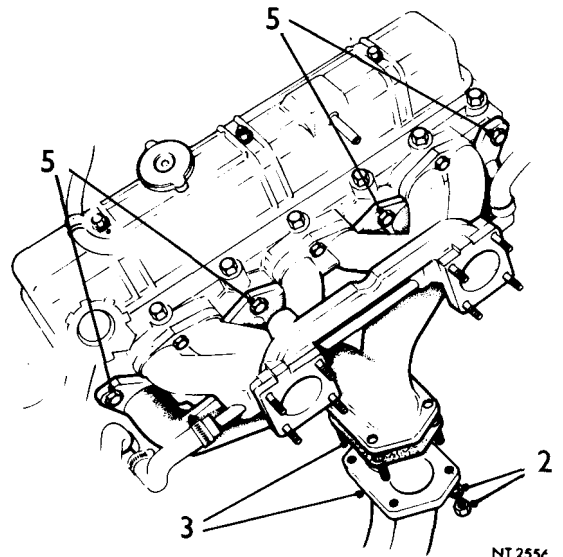

NT 255c

## INDUCTION MANIFOLDS (PETROL INJECTION MODELS)

\*\* (Up to Engine No. CP 77609E) \*\*

– Remove and refit 30.15.02

### Removing

1. Remove the air intake manifold 19.70.01.
2. Disconnect the brake servo hose from the rear manifold.
3. Disconnect the metering control hose from the centre manifold.
4. Disconnect the air intake manifold hose from the front manifold – one corbin clip.
5. Remove the cold start cam return spring.
6. Slacken the trunnion bolt.
7. Remove the lower locknut and disconnect the cold start cable.
8. Remove the split pin and clevis pin.
9. Remove the lower locknut and disconnect the throttle cable.
10. Remove the three setscrews, lockwashers and clamp plates.
11. Remove the injectors.
12. Remove the six nuts, lockwashers and clamps.
13. Remove the three nuts and lockwashers.
14. Pull the manifolds clear of the studs and remove them from the engine.

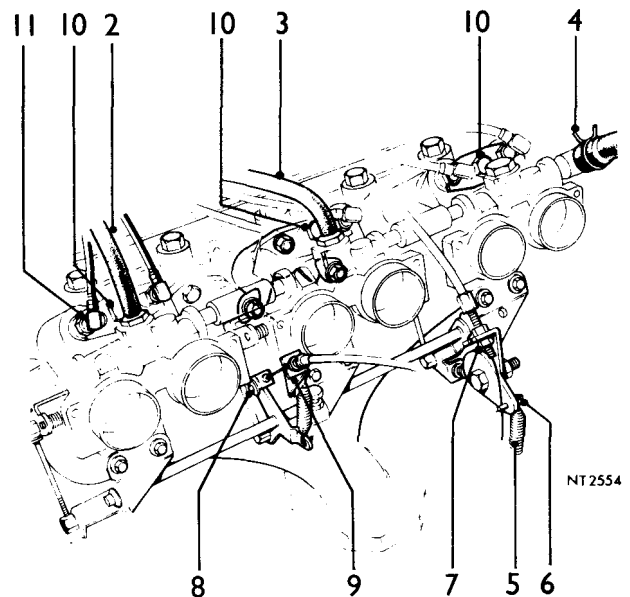

NT 2554

### Refitting

15. Reverse instructions 1 to 14, ensuring that all stud nuts are tightened to 20 to 25 lbf ft (2.8 to 3.5 kgf m).



**INDUCTION MANIFOLD (CARBURETTOR MODELS)**

– Remove and refit 30.15.02

**Removing**

1. Remove the air cleaner 19.10.01.
2. Remove the carburettor 19.15.11.
3. Partially drain the cooling system.
4. Slacken the two clips and disconnect the hoses from the water pipe.
5. Remove the six nuts, lockwashers and clamps.
6. \*\* Remove the three nuts and lock washers and (later USA Markets cars only) release the Exhaust Gas Recirculation valve connection at the induction manifold. \*\*
7. Pull the manifold clear of the studs and remove it from the engine.

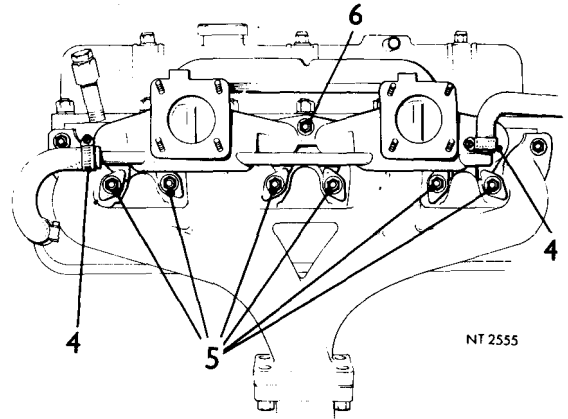

**Refitting**

8. Reverse instructions 1 to 7, ensuring that all stud nuts are tightened to 20 to 25 lbf ft (2.8 to 3.5 kgf m).

**INDUCTION MANIFOLD – FRONT (PETROL INJECTION MODELS) (From Engine No. CR1E)**

– Remove and refit 30.15.02

**Removing**

1. Remove the air intake manifold. 19.70.01.
2. Disconnect the throttle cable from the throttle linkage.
3. Remove the clamp bolt and clamp and withdraw the two injectors.
4. Ease the rubber connectors to one side on
  - a. the air rail
  - b. the balance pipe.
5. Remove the three nuts and spring washers and the two clamps securing the manifold to the cylinder head.
6. Slacken the front throttle adjusting screw clear of the butterfly lever.
7. Withdraw the manifold complete with the throttle linkage.
8. Remove the two bolts, plain and spring washers securing the throttle linkage to the manifold and remove the linkage.

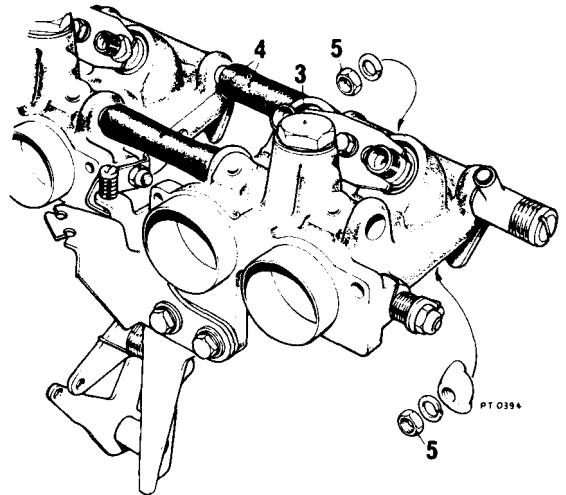

**Refitting**

9. Refit the linkage to the manifold.
10. Refit the manifold and loosely secure with the three nuts, spring washers and clamps.
11. Manoeuvre the manifold until the butterfly lever on the centre manifold is spaced equidistant between the fork lever of the front butterflies and tighten the manifold nuts.
12. Reverse instructions 2 to 4.
13. Adjust the throttle butterflies. 19.20.05.

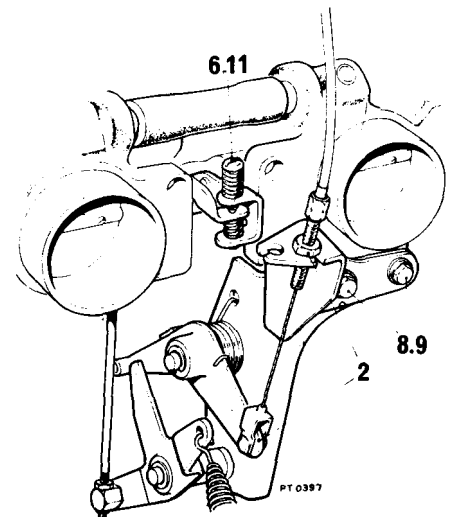

## MANIFOLD AND EXHAUST SYSTEM

### INDUCTION MANIFOLD – REAR (PETROL INJECTION MODELS) (From Engine No. CR1E)

– Remove and refit 30.15.03

#### Removing

1. Remove the air intake manifold. 19.70.01.
2. Remove the brake servo vacuum hose from the manifold.
3. Remove the clamp bolt and plate and remove the two injectors.
4. Ease the rubber connectors to one side on
  - a. the air rail
  - b. the balance pipe.
5. Slacken the rear throttle adjusting screw clear of the butterfly lever.
6. Remove the three nuts, spring washers and two clamps securing the manifold to the cylinder head.
7. Withdraw the manifold.

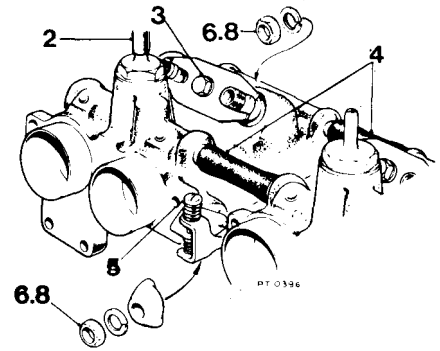

#### Refitting

8. Refit the manifold loosely securing with the three nuts, spring washers and clamps.
9. Manoeuvre the manifold so that the butterfly lever is spaced equidistant between the fork lever of the centre manifold. Finally tighten the manifold nuts.
10. Reverse instructions 2 to 4.
11. Adjust the throttle butterflies. 19.20.05.

### INDUCTION MANIFOLD – CENTRE (PETROL INJECTION MODELS) (From Engine No. CR1E)

– Remove and refit 30.15.04

#### Removing

1. Remove the air intake manifold. 19.70.01.
2. Remove the clamp bolt and clamp and withdraw the two injectors.
3. Disconnect the cold start cable from the manifold linkage.
4. Disconnect the metering unit vacuum pipe from the manifold.
5. Ease the rubber connectors to one side on
  - a. the air rail
  - b. the balance pipe.
6. Disconnect the cold start cam return spring.
7. Slacken both throttle adjusting screws clear of the butterfly levers.
8. Remove the three nuts, spring washers and clamps securing the manifold to the cylinder head.
9. Withdraw the manifold complete with the cold start linkage.
10. Remove the two bolts, spring and plain washers securing the linkage to the manifold and withdraw the linkage.

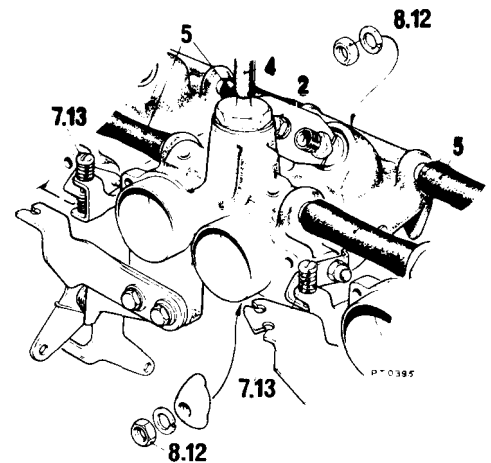

30.15.03

30.15.04

## Refitting

11. Fit the linkage to the manifold.
12. Fit and loosely secure the manifold with the three nuts, spring washers and two clamps.
13. Manoeuvre the manifold until the two butterfly levers are equidistant between the two fork levers and finally tighten the manifold nuts.
14. Reverse instructions 2 to 6.
15. Adjust the throttle butterflies. 19.20.05

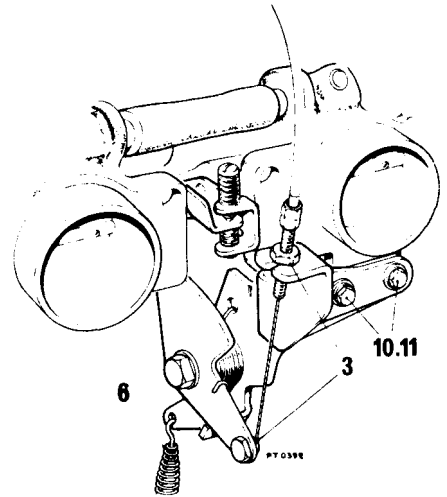

## MANIFOLD GASKET

– Remove and refit

30.15.15

### Removing

1. Remove the induction manifold 30.15.02.
2. Remove the exhaust manifold 30.15.01.
3. Remove the gasket.

### Refitting

4. Renew the gasket and fit with the metal side towards the manifold.
5. Reverse instructions 1 and 2, ensuring that all stud nuts are tightened to 20 to 25 lbf ft (2.8 to 3.5 kgf m).

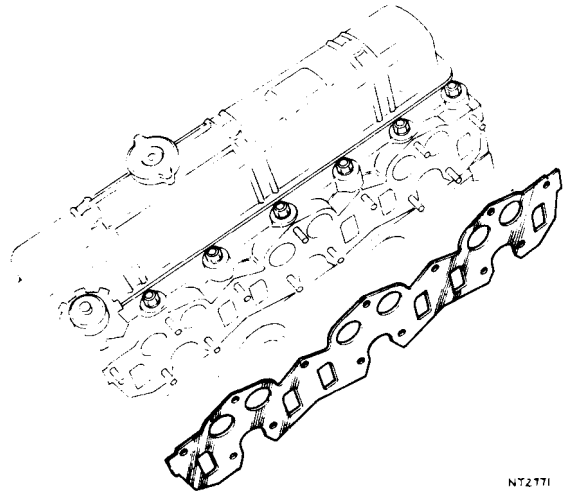

N72171

## CLUTCH OPERATIONS

Clutch assembly – remove and refit . . . . .	33.10.01
Clutch pedal – remove and refit . . . . .	33.30.02
– return spring – remove and refit . . . . .	33.30.03
Clutch withdrawal mechanism – remove and refit . . . . .	33.25.12
Fluid pipes – remove and refit . . . . .	33.15.09
Hydraulic system – bleed . . . . .	33.15.01
Master cylinder – overhaul . . . . .	33.20.07
– remove and refit . . . . .	33.20.01
Slave cylinder – overhaul . . . . .	33.35.07
– remove and refit . . . . .	33.35.01

## CLUTCH ASSEMBLY

– Remove and refit

33.10.01

## Removing

1. Remove the gearbox 37.20.01.
2. Progressively slacken and remove the six bolts and spring washers securing the clutch to the flywheel.
3. Withdraw the clutch and the driven plate.

## Refitting

4. Offer up the driven plate to the flywheel using a dummy input shaft. The longer boss of the driven plate hub must be fitted away from the flywheel.
5. Engage the clutch assembly in the three flywheel locating dowels.
6. Fit and evenly tighten the six securing bolts and spring washers. (torque 16 to 20 lbf ft – 2.2 to 2.8 kgf m).
7. Withdraw the dummy input shaft.
8. Refit the gearbox 37.20.01.

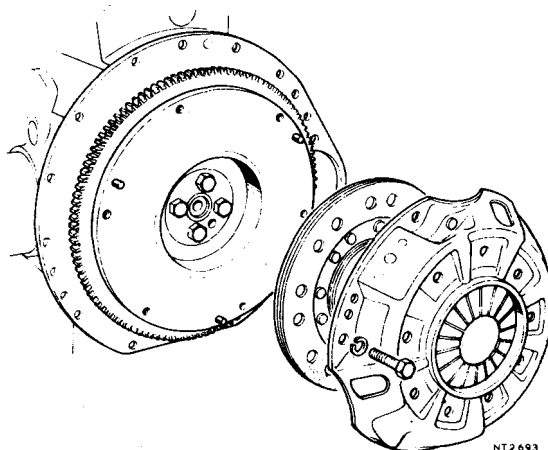

## HYDRAULIC SYSTEM

– Bleed

33.15.01

1. Check the level of fluid in the master cylinder reservoir and top up as necessary.
2. Attach a bleed tube to the nipple on the slave cylinder. Allow the free end of the tube to hang submerged in brake fluid in a transparent container.
3. Slacken the bleed nipple (90 to 180 degrees is usually adequate).
4. Depress the clutch pedal and allow the pedal to return. Continue until fluid free of air issues from the slave cylinder. Hold the pedal depressed, close the bleed nipple and release the pedal.
5. Remove the bleed tube and container.
6. Top up the reservoir. It is necessary to ensure that the fluid in the reservoir is never permitted to fall to a level whereby air can be admitted to the system. When topping up the reservoir do not use the aerated and possibly contaminated fluid exhausted from the system during the process of bleeding.

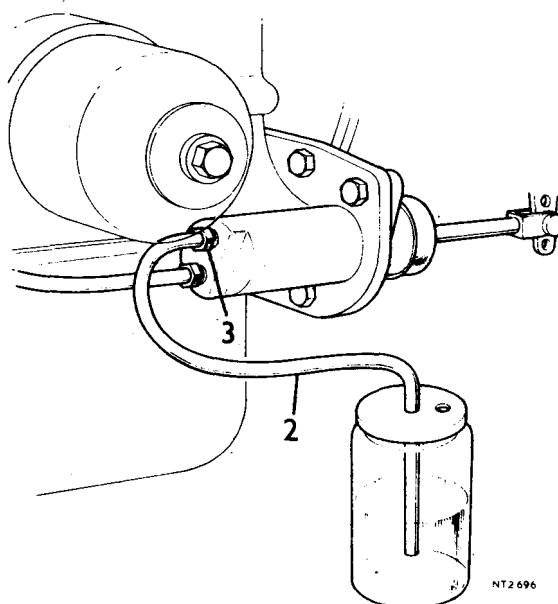

# CLUTCH

## FLUID PIPE

– Remove and refit

33.15.09

### Removing

1. Disconnect the fluid pipe union from the clutch master cylinder.
2. Disconnect the fluid pipe union at the upper end of the flexible pipe.
3. Release the fluid pipe from its retaining clips and remove the pipe from the car.
4. Unscrew the flexible pipe union at the slave cylinder.

### Refitting

5. Align the pipe in position on the car.
6. Screw the flexible pipe lower union to the slave cylinder.
7. Secure the pipe in its retaining clips.
8. Connect the pipe unions to the clutch master cylinder and the upper end of the flexible pipe.
9. Bleed the system 33.15.01.

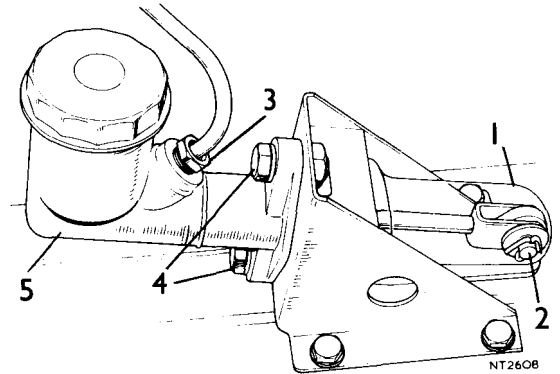
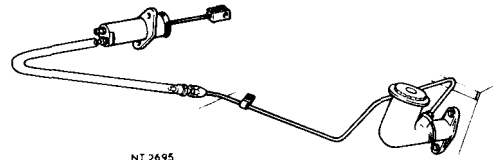
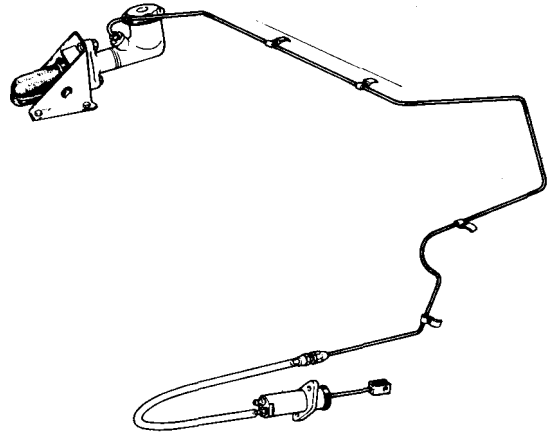

## MASTER CYLINDER

– Remove and refit

33.20.01

### Removing

1. Lift the rubber boot at the front of the master cylinder bracket to expose the clutch pedal/master cylinder linkage. (*Right hand steering models only*).
2. Remove the split pin, washer and clevis pin securing the clutch pedal to the master cylinder push rod.
3. Disconnect the fluid pipe from the master cylinder.
4. Remove the two bolts and spring washers securing the master cylinder flange to the mounting bracket, or scuttle as appropriate.
5. Withdraw the master cylinder.

### Refitting

6. Reverse instructions 1 to 5.
7. Bleed the system.

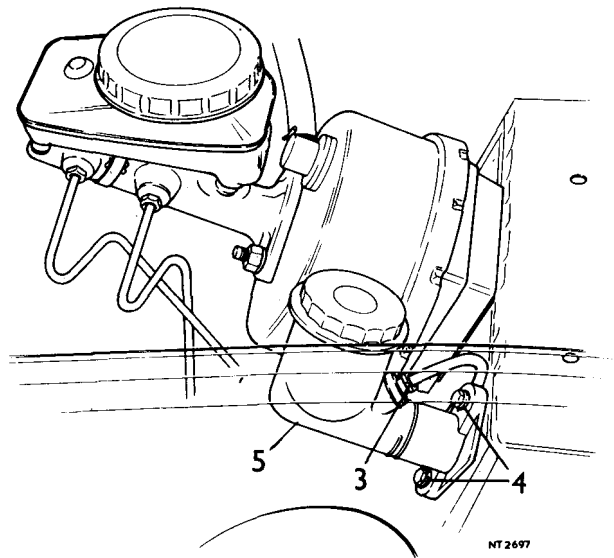

## MASTER CYLINDER

## — Overhaul

33.20.07

1. Remove the master cylinder from the car 33.20.01
2. Drain the fluid reservoir.
3. Detach the rubber boot from the master cylinder and withdraw it from the push rod.
4. Remove the circlip retaining the push rod to the master cylinder and withdraw the push rod and washer.
5. Withdraw the piston, spring, and seal assembly.
6. Straighten the prong of the spring thimble and remove the thimble and spring from the piston.
7. Release the valve stem from the keyhole slot in the thimble.
8. Slide the valve seal spacer along the valve stem.
9. Remove the valve seal from the valve stem and fit a new seal.
10. Assemble the spacer, and thimble to the valve stem.
11. Remove the seal from the piston and fit a new seal (seal lip towards the spring).
12. Fit the spring thimble to the piston and carefully depress the thimble prong.
13. Lubricate the bore of the master cylinder with clean brake fluid and insert the seal assembly and piston.
14. Fit the push rod and washer to the master cylinder and secure with a circlip.
15. Fit a new rubber boot to the push rod and master cylinder.
16. Fit the cylinder to the car 33.20.01.
17. Bleed the system 33.15.01.

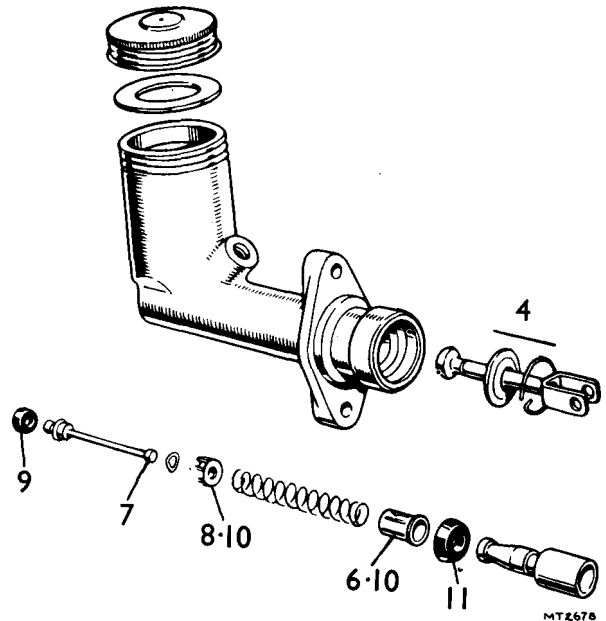

# CLUTCH

## CLUTCH WITHDRAWAL MECHANISM

– Remove and refit

33.25.12

### Removing

1. Remove the gearbox 37.20.01.
2. Withdraw the release bearing assembly from the gearbox front end cover.
3. Remove the locking wire from the square-headed pinch pin securing the withdrawal link to the withdrawal shaft.
4. Remove the pinch pin.
5. Remove the withdrawal shaft, anti-rattle spring and the withdrawal fork.

### Refitting

6. Slide the release bearing assembly into position on the gearbox front end cover.
7. Fit the tapered coil anti-rattle spring to the withdrawal shaft (narrow end of taper adjacent to the drop arm).
8. Rotate the release bearing assembly to position the anti-rotation pin centrally above the gearbox primary shaft (12 o'clock position).
9. Engage the withdrawal fork in the release bearing assembly ensuring that the machined flats on the fork ends are located on the engine side of the withdrawal shaft.
- 10.\*\*Slide the withdrawal shaft through the bushes and the withdrawal fork.\*\*
11. Align the screwed boss of the withdrawal shaft and fit and tighten the square-headed pinchbolt.
12. Secure the pinchbolt with locking wire.
13. Fit the gearbox to the car 37.20.01.

**NOTE:** that the slave cylinder push rod should engage the centre hole in the withdrawal shaft drop arm.

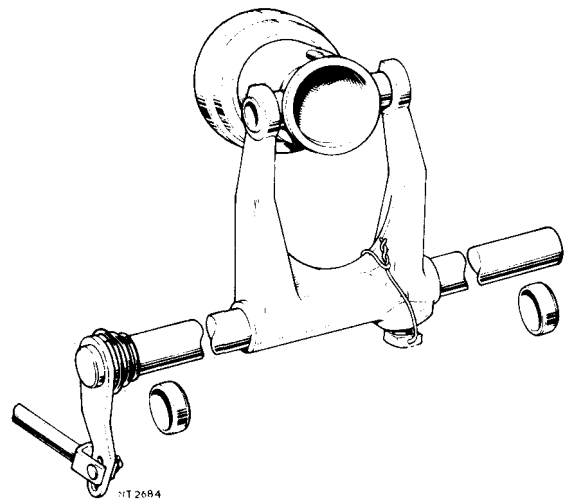
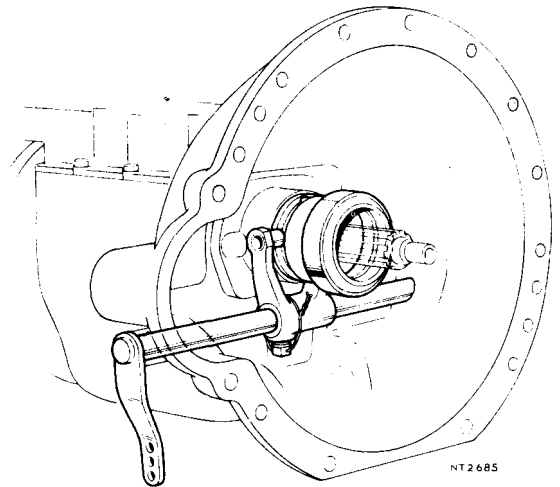

## CLUTCH PEDAL

– Remove and refit

33.30.02

Refer 70.35.01

## CLUTCH PEDAL RETURN SPRING

– Remove and refit

33.30.03

### Removing

1. Release the spring hook from the pedal box.
2. Release the spring hook from the clutch pedal.

### Refitting

3. Reverse instructions 1 and 2.

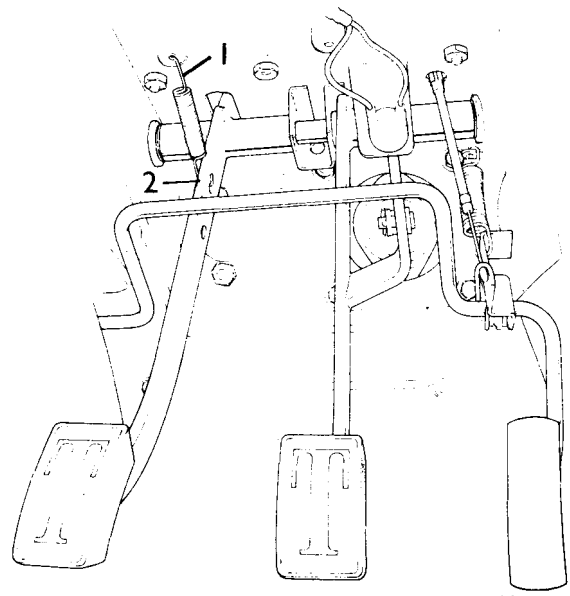

33.25.12

33.30.02/03



## SLAVE CYLINDER

– Remove and refit

33.35.01

## Removing

1. Disconnect the union at the upper end of the flexible pipe.
2. Unscrew the flexible pipe union from the slave cylinder and remove the clevis pin.
3. Remove the two nuts, spring washers and bolts securing the slave cylinder flange to the mounting bracket.
4. Withdraw the slave cylinder.

## Refitting

5. Reverse instructions 1 to 4.

**NOTE:** that the slave cylinder push rod, should be fitted to the centre hole in the withdrawal shaft drop arm.

6. Bleed the system.

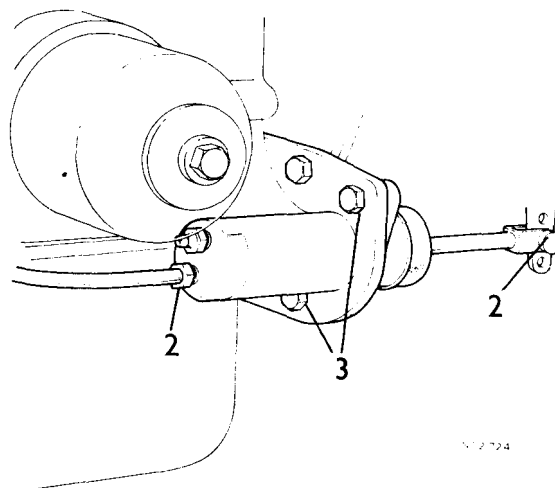

## SLAVE CYLINDER

– Overhaul

33.35.07

1. Remove the slave cylinder from the car. 33.35.01.
2. Withdraw the rubber boot and push rod.
3. Withdraw the piston, seal, filler block and spring.
4. Thoroughly clean all components and examine the cylinder bore, piston and filler block for signs of damage, scoring and corrosion. If doubt exists as to their serviceability a new slave cylinder assembly should be obtained.
5. Lubricate the cylinder bore with clean brake fluid.
6. Fit the spring to the filler block and enter the block (spring leading) into the bore.
7. Fit a new seal (lips leading).
8. Fit the piston (plain face leading).
9. Fit a new rubber boot and insert the push rod.
10. Fit the slave cylinder to the car 33.35.01.
11. Bleed the system 33.15.01.

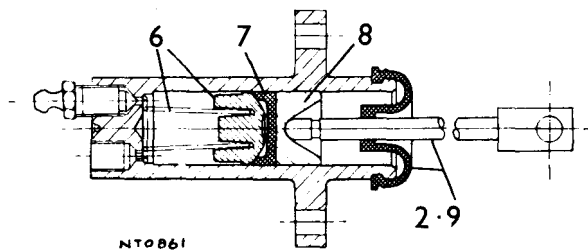

**SYNCHROMESH GEARBOX OPERATIONS**

Constant pinion assembly – overhaul . . . . .	37.20.34
Countershaft – overhaul . . . . .	37.20.29
Drive flange – remove and refit . . . . .	37.10.01
Front oil seal – remove and refit . . . . .	37.23.06
Gearbox assembly	
– Overhaul . . . . .	37.20.04
– remove and refit . . . . .	37.20.01
Gearchange lever	
– check and adjust . . . . .	37.16.01
– remove and refit . . . . .	37.16.04
Rear extension – remove and refit . . . . .	37.12.01
Rear extension – overhaul . . . . .	37.12.04
Rear oil seal – remove and refit . . . . .	37.23.01
Speedometer drive pinion assembly	
– overhaul . . . . .	37.25.13
– remove and refit . . . . .	37.25.09
Synchro units	
– overhaul . . . . .	37.20.08
Top cover	
– overhaul . . . . .	37.12.19
– remove and refit . . . . .	37.12.16



# SYNCHROMESH GEARBOX

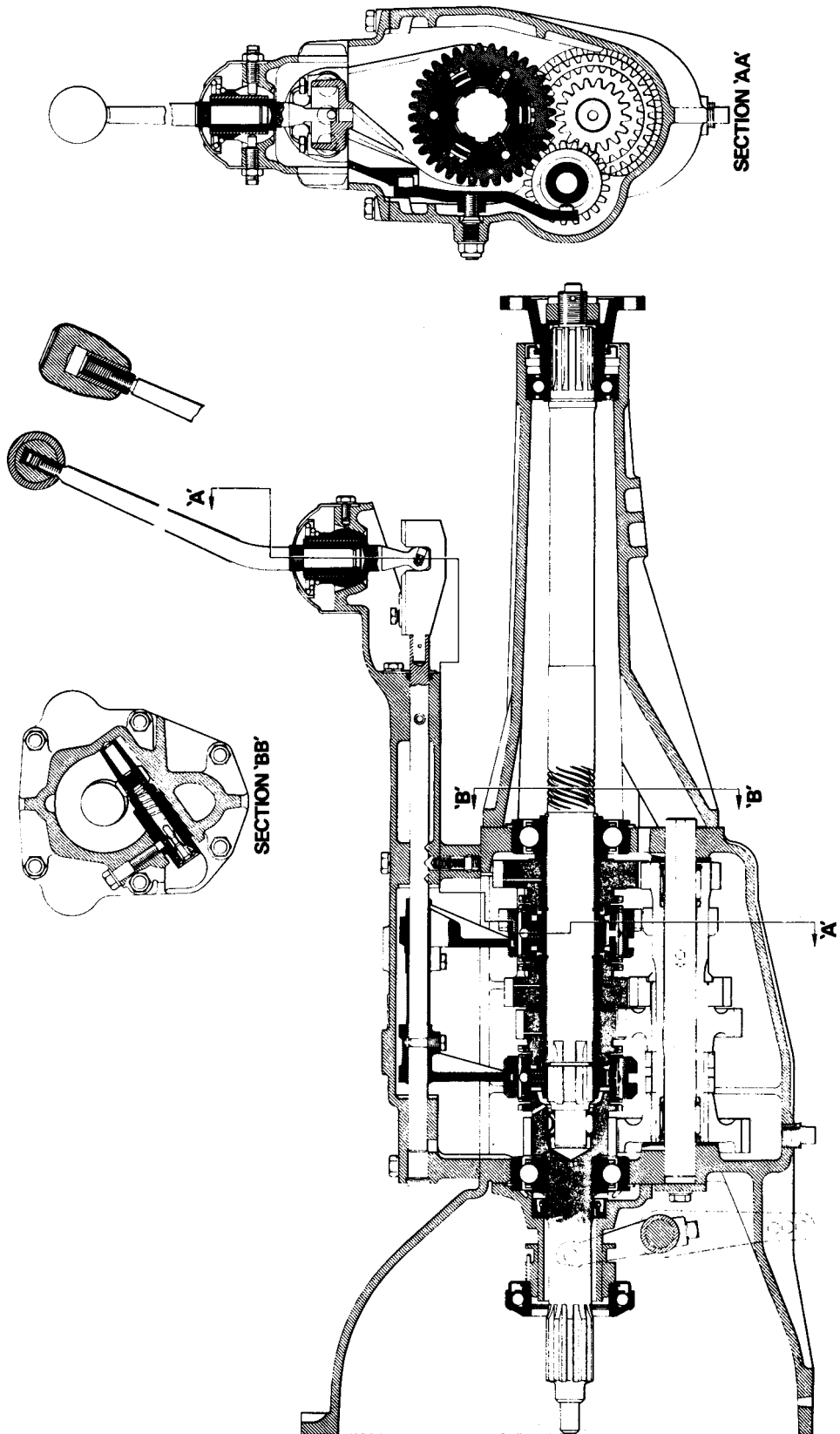

## DRIVE FLANGE

– Remove and refit

37.10.01

Service tools: RG421

### Removing

1. Drive the vehicle onto a ramp and raise the ramp.
2. Remove the propeller shaft 47.15.01.
3. Using tool RG421 to retain the drive flange, unscrew and remove the nut and washer.
4. Remove the drive flange.

### Refitting

5. Thoroughly clean the mainshaft and drive flange splines.
6. Fit the drive flange.
7. Refit the washer and nut.
8. Using tool RG421 to retain the flange, tighten the nut to 90 to 110 lbf ft (12.4 to 15.2 kgf m).
9. Refit the propeller shaft 47.15.01.

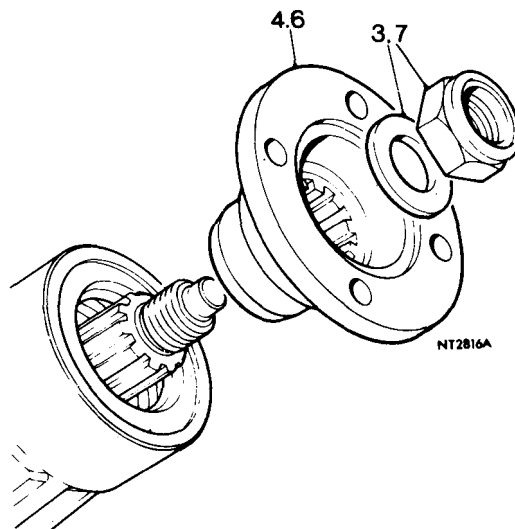

# SYNCHROMESH GEARBOX

## REAR EXTENSION

– Remove and refit

37.12.01

Service tools: RG421

### Removing

1. Drive the vehicle onto a ramp and raise the ramp.
2. Remove the exhaust intermediate pipes, silencer and tail pipes.
3. Remove the propeller shaft 47.15.01.
4. Using tool RG421 to retain the drive flange, unscrew and remove the nut and washer.
5. Remove the drive flange.
6. Unscrew and remove the peg bolt and washer.
7. Withdraw the speedometer drive cable and pinion assembly.
8. Using a ramp jack, support the gearbox and remove the rear mounting platform attachment bolts and nuts.
9. Remove the two mounting bolts and nuts.  
\*\*Later Models. Swing the steady strap forward and clear of the rear extension\*\*.
10. Raise the gearbox and remove the mounting. Lower the gearbox.
11. Place a drip tray under the gearbox.
12. Unscrew and remove the bolts.
13. Withdraw the extension housing, thrust washer and gasket.

### Refitting

14. Clean the mating faces of the gearbox casing and extension housing and fit a new gasket.
15. Refit the extension housing assembly and thrust washer.
16. Fit and tighten the extension housing bolts.
17. Refit the speedometer drive cable and pinion assembly.
18. Locate and tighten the peg bolt.
19. Refit the drive flange.
20. Fit the nut and washer.
21. Using tool RG421 to retain the flange, tighten the nut to 90 to 110 lbf ft (12.4 to 15.2 kgf m).
22. Refit the mounting.
- 23.\*\* Refit the two mounting bolts and nuts and on later models the steady strap.\*\*
24. Fit and tighten the four mounting bolts and nuts.
25. Refit the propeller shaft.
26. If necessary top up the gearbox, with oil.
27. Refit the exhaust system.

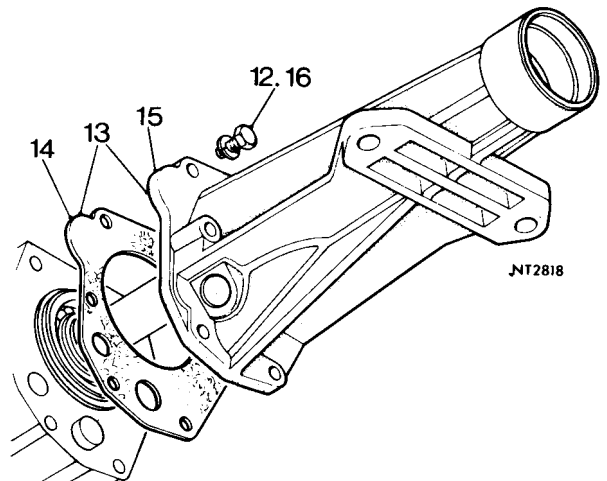
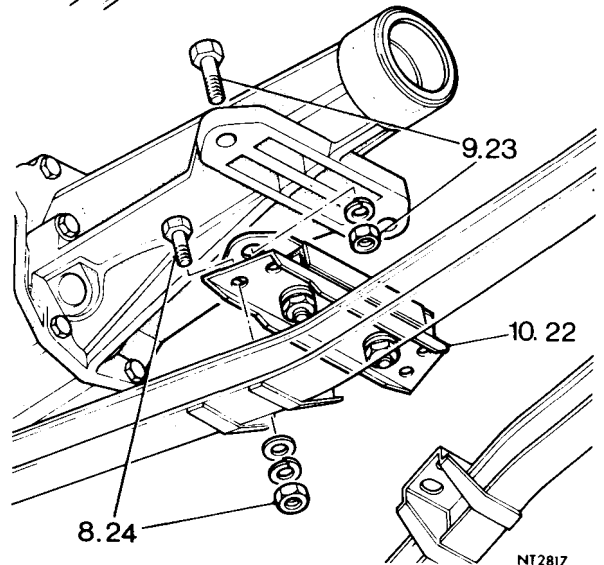
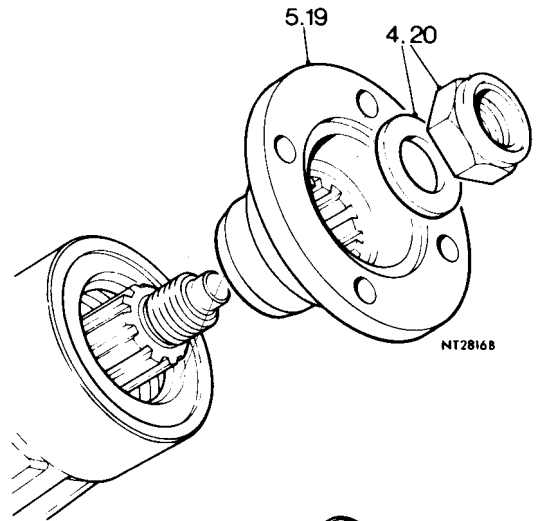

**REAR EXTENSION**

– Overhaul

37.12.04

1. Remove the rear extension 37.12.01.

**Dismantling**

2. Prise out the oil seal.
3. Drive out the bearing.

**Reassembling**

4. Drift the bearing into the extension.
5. Press a new oil seal into the extension.
6. Refit the rear extension.

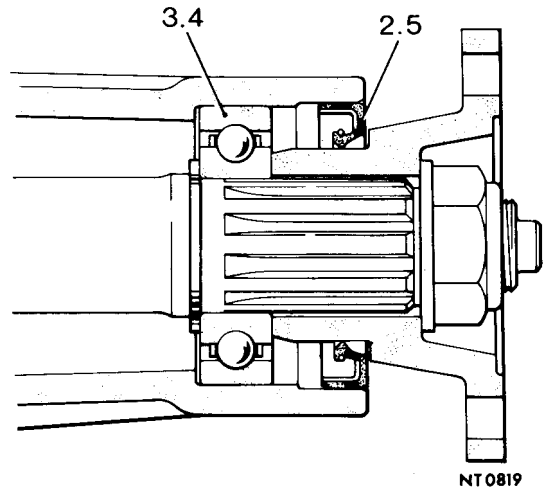

**TOP COVER**

– Remove and refit

37.12.16

**Removing**

1. Remove the transmission cover panel 76.25.07 (includes gearlever removal 37.16.04).
- \*\* 2.(a) Disconnect the reverse lamp and overdrive isolator switch leads.
- 2.(b) Later Models – Release steady strap from top cover.\*\*
3. Remove eight bolts.
4. Lift off the top cover assembly and the gasket.

**Refitting**

5. Apply grease to the abutment faces and fit the gasket.
6. Place the selector shafts in the neutral position and fit the top cover assembly. Ensure that the reverse lever is correctly engaged.
7. Secure the top cover with the following bolts, each fitted with a lock washer:
  - a. Two bolts – 67 mm long – to front
  - b. Two bolts – 73 mm long – to rear
  - \*\* c. Four bolts to sides

- \*\* 8.(a) Connect the reverse lamp and overdrive isolator switch leads.
- 8.(b) Later Models – Connect the steady strap.\*\*
9. Refit the transmission cover panel 76.25.07 (includes refitting gearlever 37.16.04).

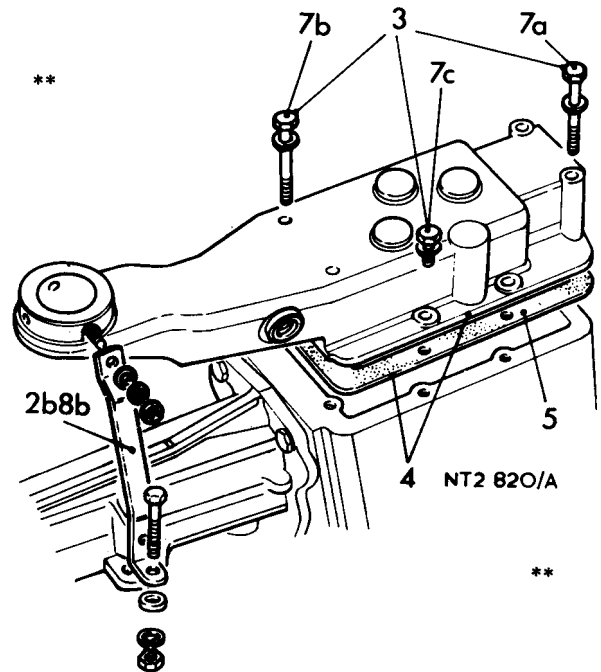

# SYNCHROMESH GEARBOX

## TOP COVER

– Overhaul

37.12.19

1. Remove the top cover 37.12.16

### Dismantling

2. Remove the reverse lamp switch and overdrive isolator switches (if fitted).
3. Remove the screwed plug, distance piece, spring and plunger – reverse detent.
4. Remove the screwed plug, spring and steel ball – 3rd/top detent.
5. Remove the screwed plug, spring and steel ball – 1st/2nd detent.
6. Remove three “wedglok” bolts – one from each selector shaft.
7. Move the three selector shafts into their neutral positions.
8. Withdraw the 1st/2nd selector shaft.
9. Remove the 1st/2nd selector fork and distance tube.
10. Withdraw the reverse selector shaft
11. Remove the reverse actuator and distance tube.
12. Withdraw the 3rd/top selector shaft.
13. Remove the 3rd/top selector fork and distance tube.
14. Remove the interlock plunger and interlock balls.
15. Unscrew two setscrews and remove the cover plate.
16. Remove the sealing rings.

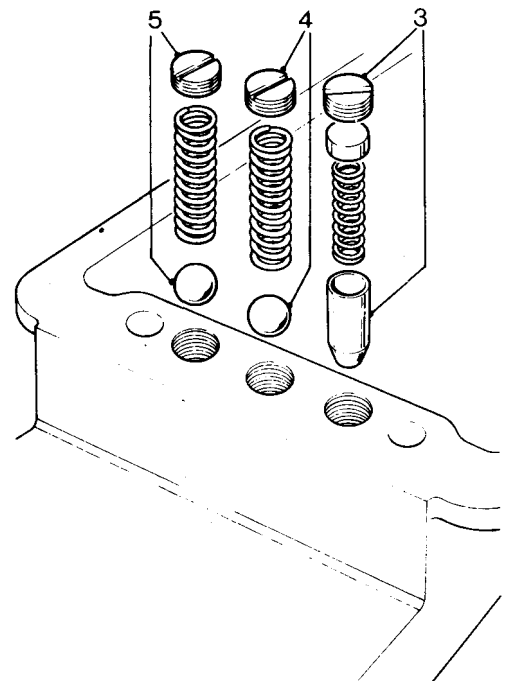

NT0833A

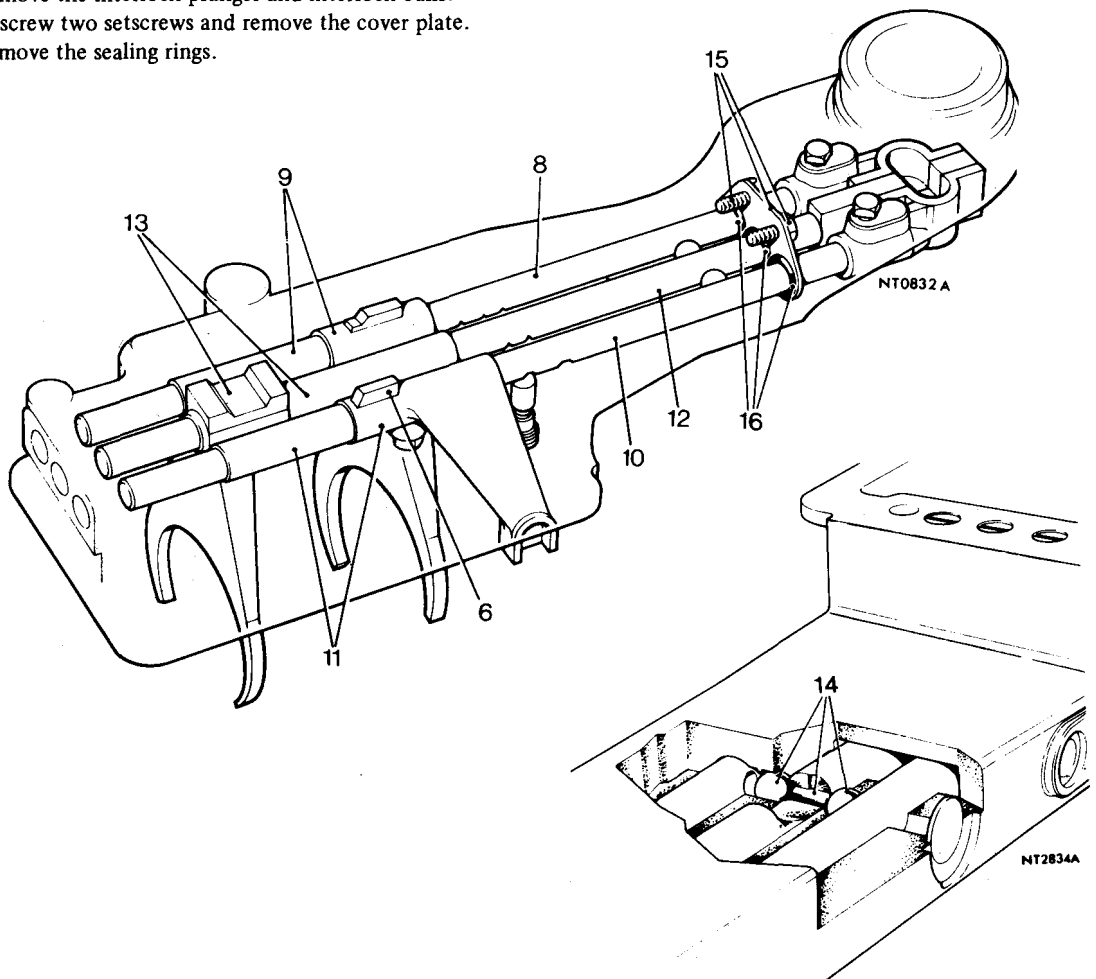

NT2834A

Reassembling

17. Fit a sealing ring into each bore.
18. Fit the cover plate and secure with two setscrews.
19. Fit the interlock plunger into the 3rd/top selector, shaft.
20. Fit the 3rd/top selector shaft, distance tube and fork into the top cover. Push the shaft into the neutral position.
21. Locate an interlock ball in-between the 3rd/top and reverse shaftbores and retain with grease.
22. Fit the reverse selector shaft, distance tube and actuator into the top cover. Push the shaft into the neutral position.
23. Locate an interlock ball in between the 3rd/top and 1st/2nd bores and retain with grease.
24. Fit the 1st/2nd selector shaft, distance tube and fork into the top cover.
25. Secure the forks and actuator to the shafts using new "wedglok" bolts.

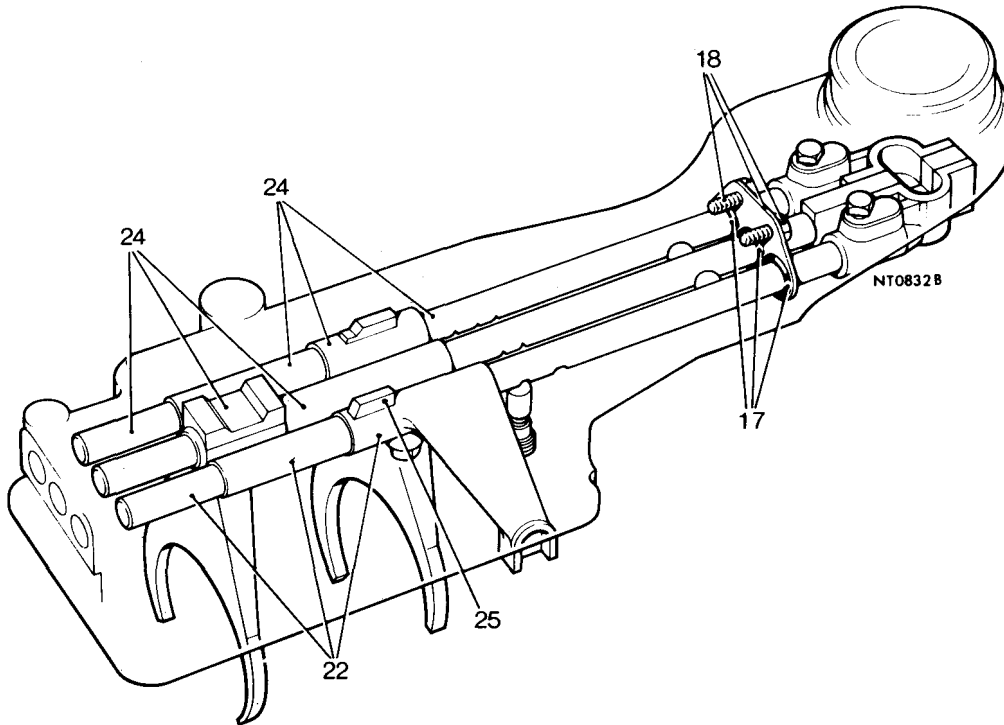
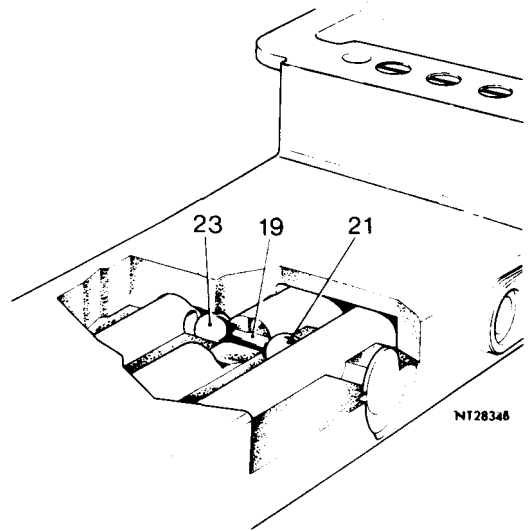



## SYNCHROMESH GEARBOX

26. Refit the reverse detent plunger, spring distance piece and screwed plug.
27. Refit the 1st/2nd detent ball, spring and screwed plug.
28. Refit the 3rd/top detent ball, spring and screwed plug.
29. Check the pull off loads using a spring balance.  
1st/2nd and 3rd/top \*\* – 32 to 34 lbf (14.5 to 15.4 kgf.)  
Reverse – 26 to 28 lbf (11.8 to 12.7 kgf.) \*\*  
Insert shims or grind springs to adjust.
30. Refit the reverse lamp switch and overdrive isolator switches.
31. Refit the top cover assembly.

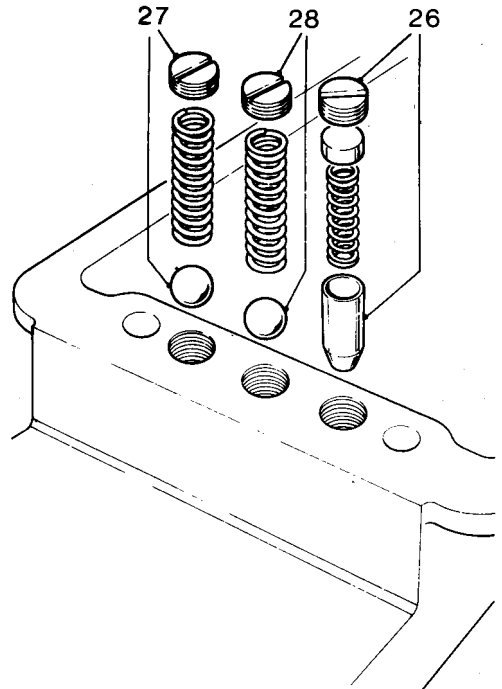

NT08338

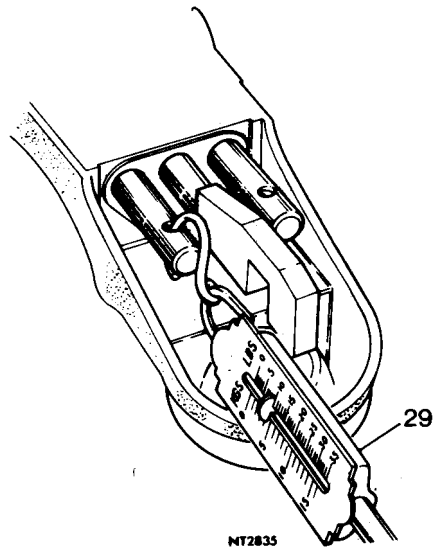

**GEAR CHANGE LEVER**

– Check and adjust 37.16.01

1. Remove the gearlever knob and locknut.
2. Remove the fascia support bracket.
3. Slacken the locknuts.
4. Place the lever in the 1st/2nd gate.
5. Tighten the right hand adjuster until it just moves the gearlever. Back off the adjuster a half turn and tighten the locknut.
- \*\* 6. Place the lever in the reverse gate. \*\*
7. Tighten the left hand adjuster until it just moves the gearlever. Back off the adjuster a half turn and tighten the locknut.
8. Refit the fascia support bracket.
9. Refit the gearlever knob and locknut.

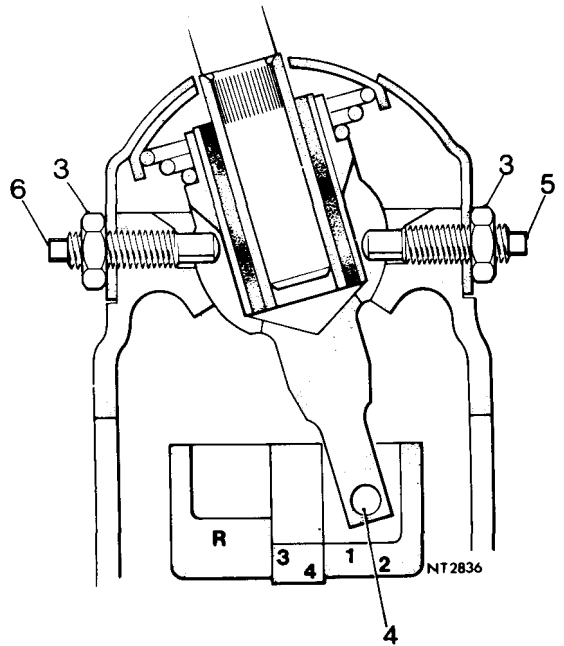

**GEARCHANGE LEVER**

– Remove and refit 37.16.04

**Removing**

1. Slacken the locknut and unscrew the gearlever knob.
2. Remove the fascia support bracket 76.46.09.
3. Remove the gearlever grommet.
4. Position the gearlever in neutral.
5. Take out the bolt.
6. Slacken the locknuts.
7. Depress and turn the gearlever cap, withdraw the cap, plate and spring.
8. Carefully withdraw the gearchange lever ensuring that the plunger and spring do not fall out.

**Refitting**

9. Using heavy grease to retain the plunger and spring, refit the gearchange lever.
10. Refit the spring, plate and cap.
11. Refit the bolt.
12. Adjust the gearchange lever 37.16.01.
13. Refit the grommet.
14. Refit the fascia support bracket.
15. Refit the gearlever knob and locknut.

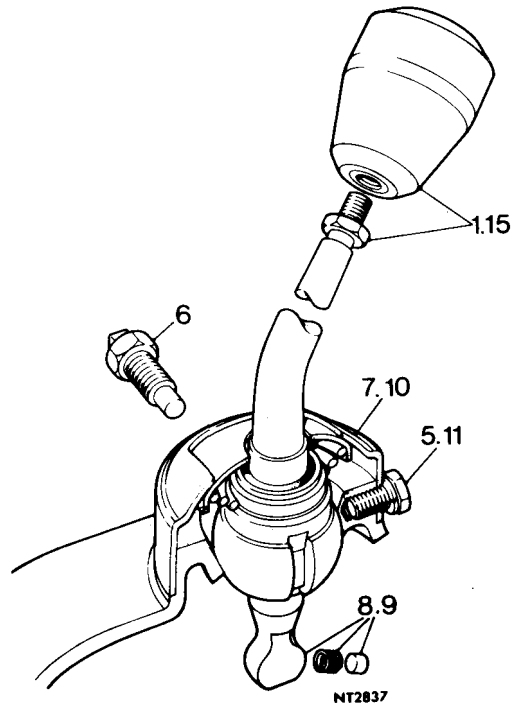

# SYNCHROMESH GEARBOX

## GEARBOX ASSEMBLY

– Remove and refit

37.20.01

### Removing

1. Drive the vehicle onto a ramp and isolate the battery.
2. Remove both front seats 76.70.04-05
3. Remove transmission side trim panels 76.13.06
4. Remove the fascia support bracket 76.46.09
5. Remove the gearlever 37.16.04.
6. Remove the carpet and the transmission cover panel. 76.25.07.
7. Disconnect the propeller shaft from the gearbox drive flange.
8. Disconnect the speedometer drive cable.
9. Unscrew and remove the mounting bolts and nuts.

\*\* NOTE: On later models note the position of fixings for the steady bracket.\*\*

10. Remove the exhaust support bracket.
11. Remove the mounting plate bolts.
12. Unscrew nine upper engine/bellhousing attachments.
13. Raise the ramp.
14. Disconnect the clutch slave cylinder push-rod from the cross-shaft lever.
15. Position a ramp jack under the engine and raise the engine/gearbox sufficient to remove the mounting plate assembly.
16. Remove the remaining (seven) engine/bellhousing attachments.
17. Lower the ramp and lift out the gearbox.

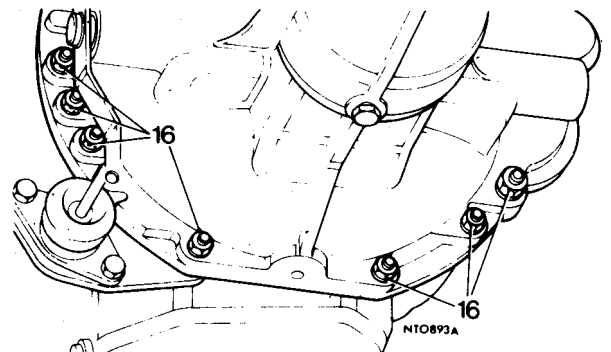
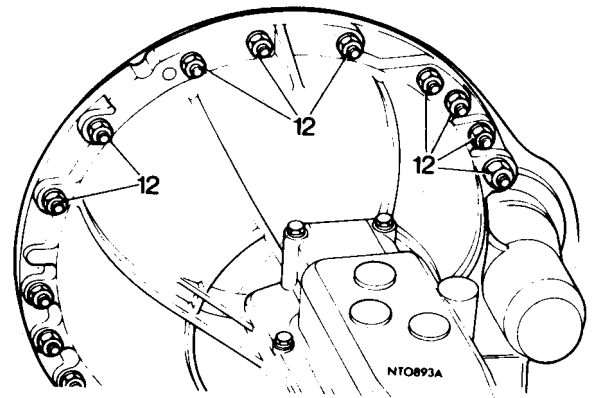
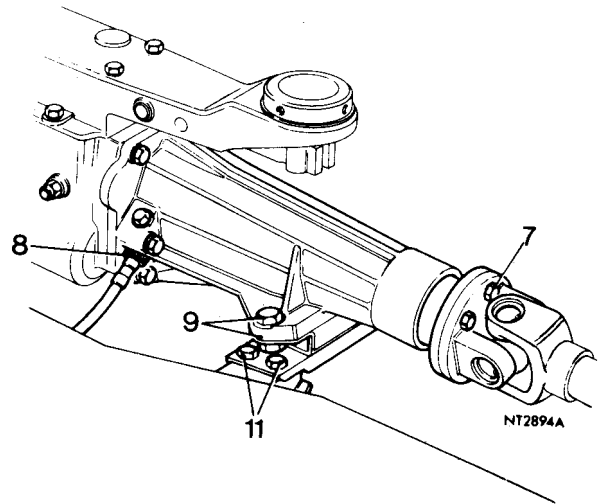

## Refitting

18. Check the alignment of the clutch splines, move the clutch throwout bearing to the rear extent of its travel and engage top gear.
19. Manoeuvre the gearbox into position, if necessary rotating the drive flange to align the input shaft splines with those of the clutch.
20. Fit the upper (nine) engine/bellhousing attachments.
21. Raise the ramp and using the ramp jack, lift the engine.
22. Refit the lower (seven) engine/bellhousing attachments.
23. Place the mounting assembly in position and lower the ramp jack.
24. Refit the clutch slave cylinder push rod to the cross shaft lever.
25. Lower the ramp.
26. Secure the mounting plate to the chassis frame.
27. Refit the exhaust support bracket.
- 28.\*\* Refit the two bolts and nuts and on later models the steady strap.\*\*
29. Connect the speedometer cable to the gearbox.
30. Connect the propeller shaft to the gearbox drive flange.
31. Refit the transmission cover panel and carpet. 76.25.07
32. Refit the gearlever 37.16.04.
33. Refit the fascia support bracket 76.46.09.
34. Refit the transmission side trim panels 76.13.06
35. Refit both front seats 76.70.04-05
36. Re-connect the battery.

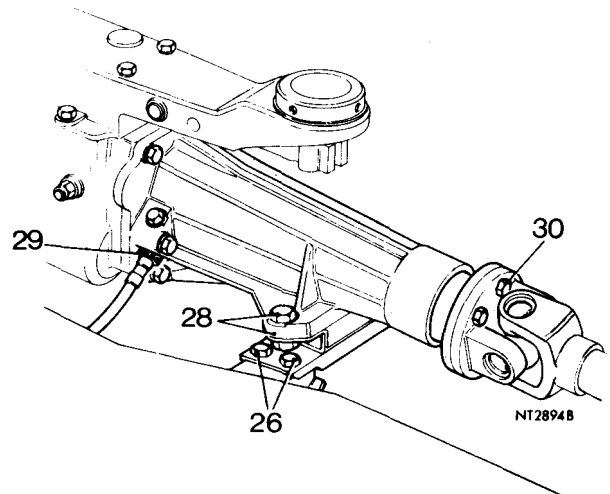
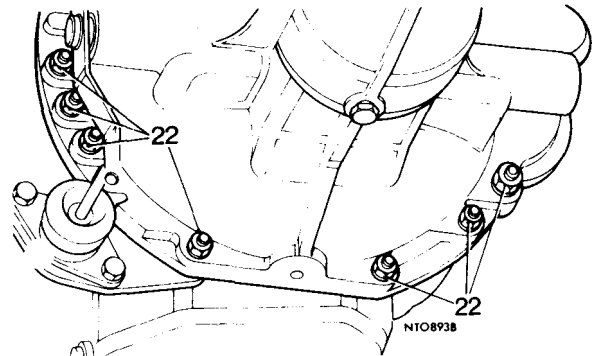
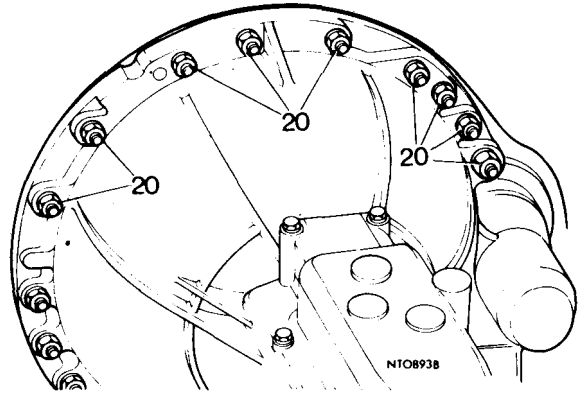

# SYNCHROMESH GEARBOX

## GEARBOX

— Overhaul

37.20.04

Service tools: RG.421, S4235A-2, S314, S4221A-15A, S67A, S167.

1. Remove the gearbox 37.20.01 and drain the oil.

### Dismantling

2. Unscrew and remove eight bolts.
3. Lift off the top cover and gasket.
4. Remove the clutch release mechanism 33.25.12.
5. Take out four setscrews and washers.
6. Tape over the constant pinion splines and remove the front bearing plate and gasket.
7. Remove the peg bolt and withdraw the speedometer drive pinion assembly (If overdrive is fitted, perform operation 40.20.07, remove the overdrive cam and adaptor plate and continue from para. 13).
8. Using tool No. RG421 to retain the flange, unscrew the nut.
9. Remove the flange.
10. Unscrew the bolts.
11. Remove the rear extension and gasket.
12. Remove the thrust washer.
13. Take out two screws.
14. Remove the countershaft front plate and gasket.
15. Take out the cross recessed head screw.
16. Remove the retaining plate.
17. Withdraw the countershaft spindle and allow the cluster to drop to the bottom of the box.
18. Using tool No. S4235A-2 withdraw the constant pinion assembly.
19. Fit the abutment tool No. S314.

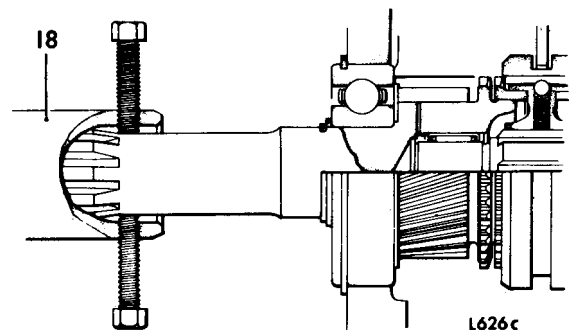
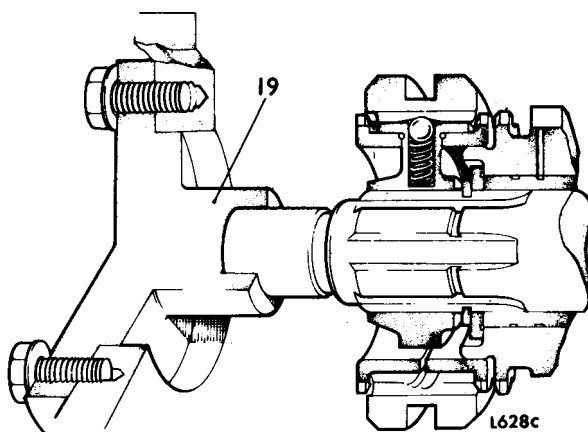
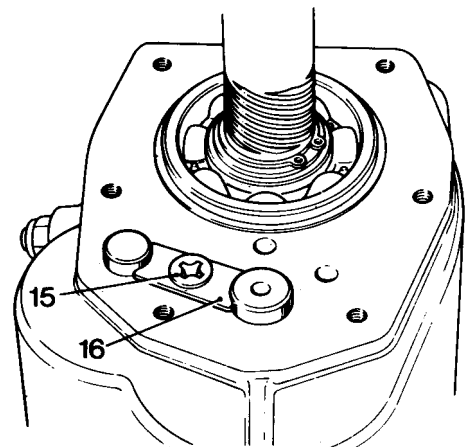
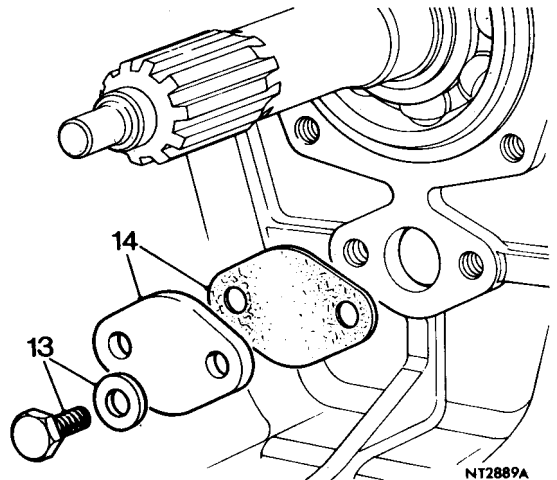

20. Remove the centre bearing circlip, washer and snap ring.
21. Using tool No. S4221A-15A, withdraw the centre bearing. Remove Tool S314.
22. Remove the mainshaft assembly through the top aperture.
23. Remove the 3rd/top synchro unit and cups.
24. Remove the washer, 1st gear and bush, washer, 1st/2nd synchro unit and cups.
25. Using tool S67A remove the circlip.

**NOTE:** The sectioned washer behind the circlip has three lugs that fit in alternate splines, the longer prongs on tool S69A fit in the splines between the lugs. Rotate circlip to ascertain position of lugs. Position circlip with ends on adjacent prongs of tool. With tool in position, gently prise between 2nd and 3rd gears to push circlip away from slot.

26. Remove the sectioned washer, 3rd gear and bush, washer, 2nd gear and bush, and washer.
27. Withdraw the reverse idler spindle, reverse gear, lever and pivot.
28. Remove the countershaft rear thrust washer.
29. Remove the countershaft assembly.
30. Remove the countershaft front thrust washer.

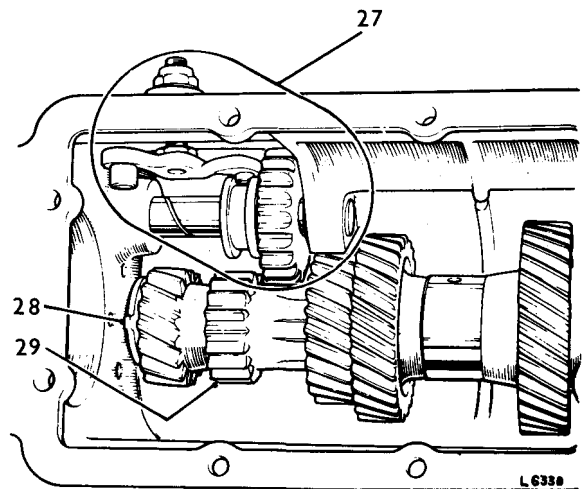
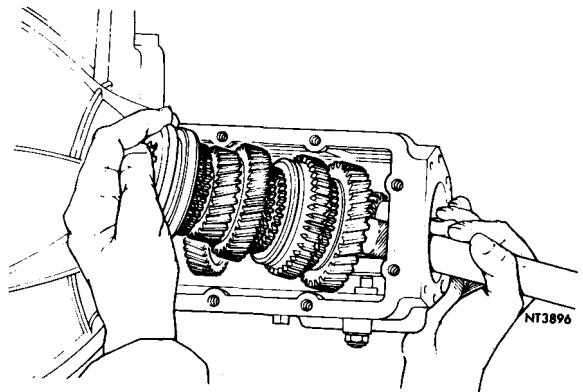
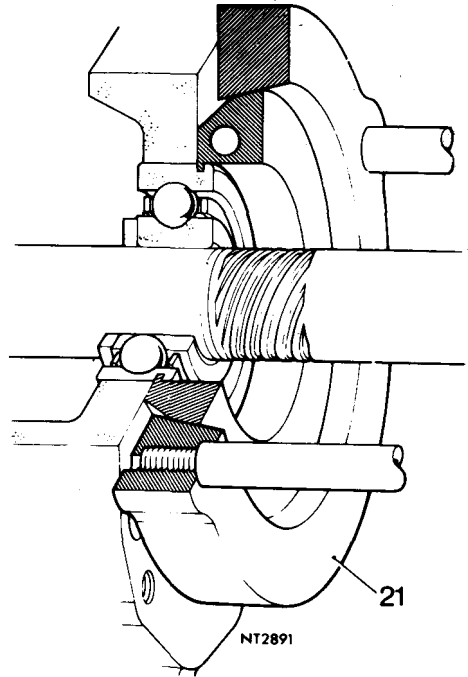

# SYNCHROMESH GEARBOX

## Reassembling

31. Refit the reverse lever with fulcrum pin, washer and nut to the gearbox.

**NOTE:** Position the lever on the pin so that two screw threads (approx) are visible between the gearbox and lever. Replace the reverse idler gear and shaft.

32. Using heavy grease to retain the thrust washers in position, fit the countershaft cluster.

33. Align the thrust washers and fit the spindle.

34. Check the countershaft end float. The end float should be 0.007 to 0.012 in (0.18 to 0.30 mm). Adjust by selective use of thrust washers or if necessary remove metal from the steel backing face of the thrust washer. Withdraw the spindle.

35. Check the end float of the 1st, 2nd and 3rd gears on their respective bushes. End float should be 0.004 to 0.008 in (0.1 to 0.2 mm).

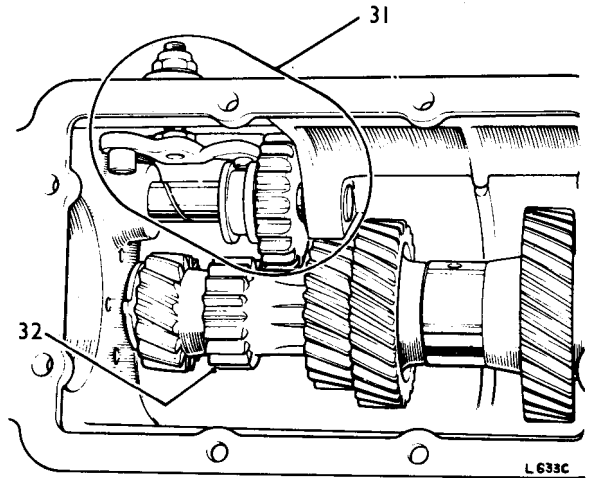

**NOTE:** i Interchange of 1st and 3rd gear bushes is permissible to obtain these figures.

ii. If necessary reduce the bush length to reduce the end float or fit a new bush to increase the end float.

36. Check the total end float of the 2nd and 3rd gear bushes on the mainshaft.

a. Temporarily fit to the front end of the mainshaft in order:

- i. Adjustment washer.
- ii. Bush — 2nd gear.
- iii. Thrust washer,
- iv. Bush — 3rd gear
- v. Thrust washer — fit reversed.
- vi. Sectioned washer — fit reversed.

b. Insert the deeper portion of a discarded circlip in its groove in the mainshaft to retain the items.

c. Measure the bush end float on the mainshaft using feeler gauges.

d. End float is to be within 0.003 to 0.009 in (0.08 to 0.23 mm).

e. Adjustment of end float is to be made by selection of the adjustment washer (a. i.) of appropriate thickness listed as follows:

Part No.	Colour	in $\pm 0.001$	Thickness mm $\pm 0.25$
129941	Metal	0.119	3.02
129942	Green	0.122	3.10
129943	Blue	0.125	3.17
129944	Orange	0.128	3.25
134670	Yellow	0.133	3.38

f. Remove the items from the mainshaft but suitably identify selected adjustment washer for association with 2nd gear.

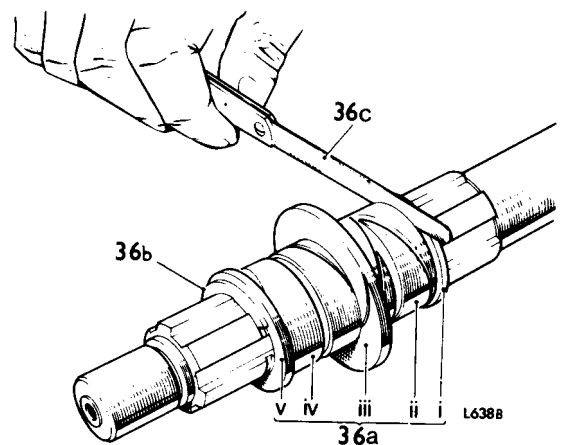
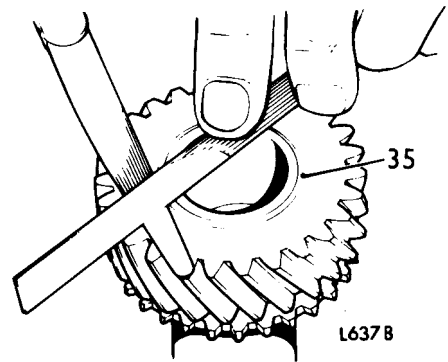

37. Check the end float of the 1st gear bush on the mainshaft.
- a. Temporarily fit the rear of the mainshaft in order:
    - i. Adjustment washer.
    - ii. Bush – 1st gear.
    - iii. Thrust washer.
    - iv. Ball bearing Tool S314.
    - v. Washer.
  - b. Insert the deeper portion of a discarded circlip in its groove in the mainshaft to retain the items.
  - c. Drift the bearing into close abutment with the washer and circlip.
  - d. Measure the bush end float on the mainshaft using feeler gauges.
  - e. End float is to be 0.003 to 0.009 in (0.08 to 0.23 mm).
  - f. Adjustment to end float is to be made by selection of the adjustment washer (a. i.) of appropriate thickness given in preceding list (36e).
  - g. Remove the items from the mainshaft but suitably identify the selected adjustment washer for association with the 1st gear. Bearing extractor tool S4221A-15A.
38. Assemble each synchro cup on the respective gear and measure with feeler gauges the clearance between the gear and cup. Should the clearance be less than 0.030 in (0.76 mm) renew the cup.
39. Assemble the front of the mainshaft in order:
- a. Adjustment washer.
  - b. Assembled 2nd gear and bush.
  - c. Thrust washer.
  - d. Assembled 3rd gear and bush.
  - e. Sectioned washer.
  - f. Circlip-Tool S176.
  - g. 3rd/4th synchro unit fitted with synchro cups (short boss innermost).
- NOTE:** Ensure correct assembly of bush and gear (b and d) in that bush and gear oilways align.
40. Assemble to the rear of the mainshaft in order:

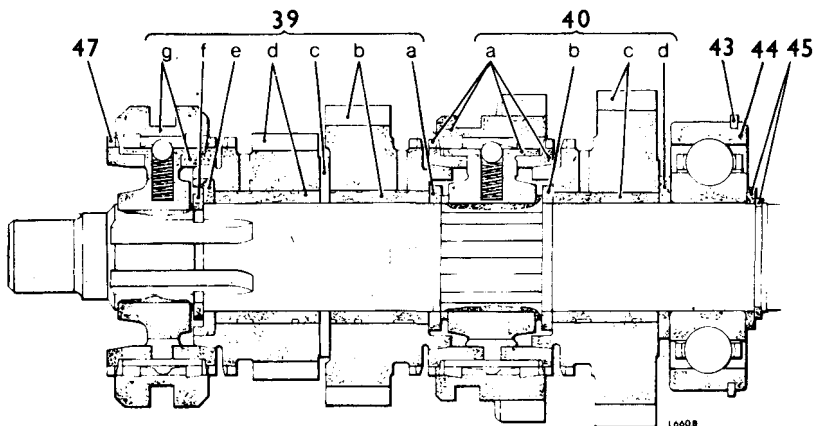
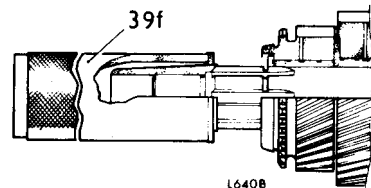
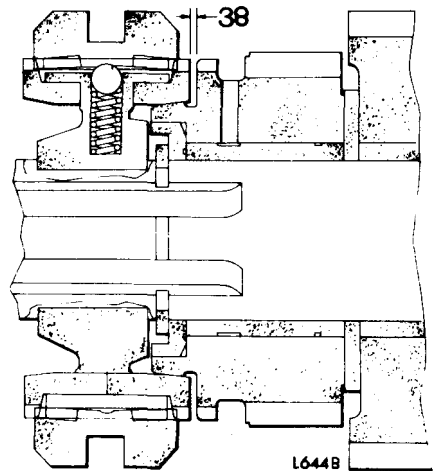
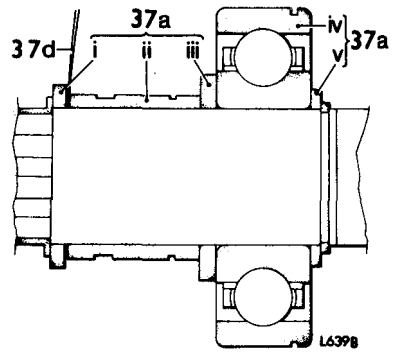



# SYNCHROMESH GEARBOX

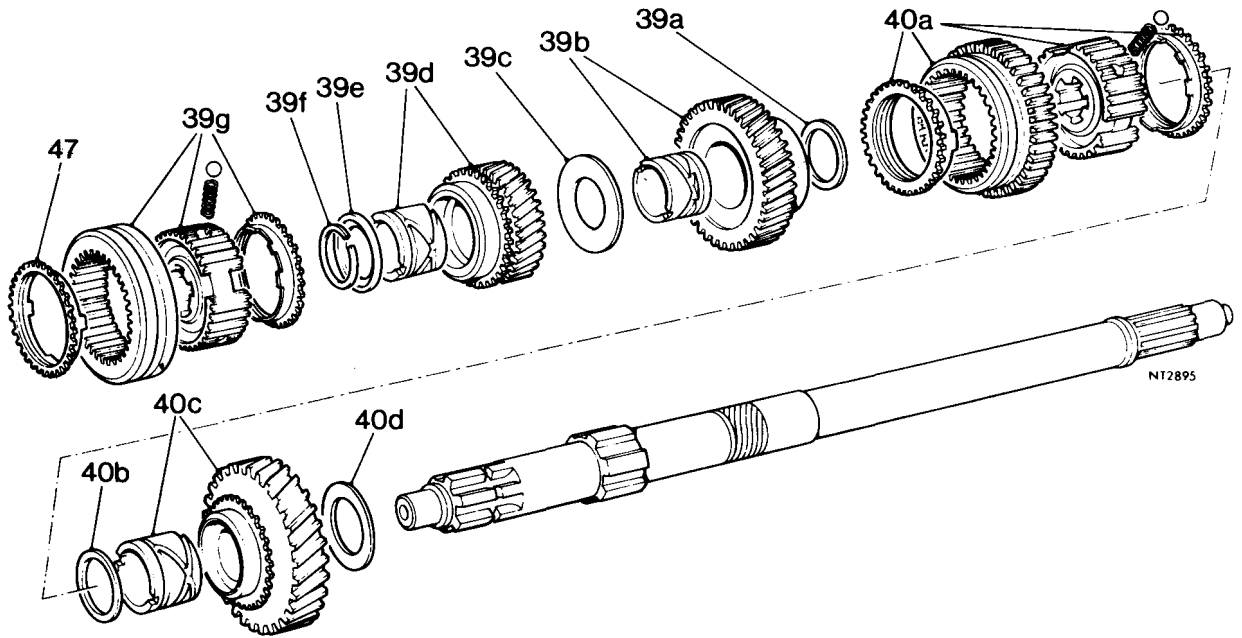

- a. 1st/2nd synchro unit fitted with synchro cups.
- b. Adjustment washer.
- c. Assembled 1st gear and bush (see 39 Note).
- d. Thrust washer.

**WARNING: IT IS RECOMMENDED THAT SEVERAL WINDINGS OF CORD ARE LASHED AROUND MAINSHAFT TO REAR OF THE 1st GEAR TO PREVENT ITS MOVEMENT, THEREBY, AVOIDING ANY POSSIBILITY OF PERSONAL DAMAGE WHEN FITTING THE MAINSHAFT.**

41. Enter the rear of the mainshaft through the top cover and rear apertures of gearbox, respectively, and manoeuvre mainshaft assembly into position.
42. Fit tool S314 to the gearbox and engage the mainshaft spigot in the tool.
43. Fit the snap ring to the bearing.
44. Fit the bearing to the mainshaft and gearbox. Tool S314. Remove the tool.
45. Remove tool S314.
46. Fit the washer and circlip to the mainshaft. Protect the rear end of the mainshaft (hard brass block), then tap on the rear end until the inner face of the mainshaft bearing is in close abutment with the washer and circlip.
47. Fit the top gear synchro cup.
48. Fit the constant pinion assembly,
49. Prior to engaging the countershaft gears, free the synchro cups with a screwdriver.
50. Carefully invert the gearbox to engage the countershaft gears – rotating the mainshaft and constant pinion shaft as necessary.
51. Align the countershaft gears and thrust washers then press home countershaft spindle.

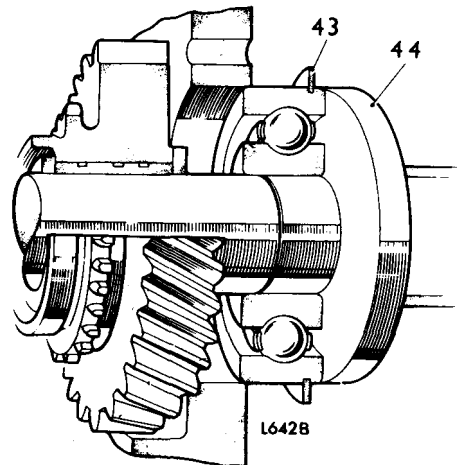
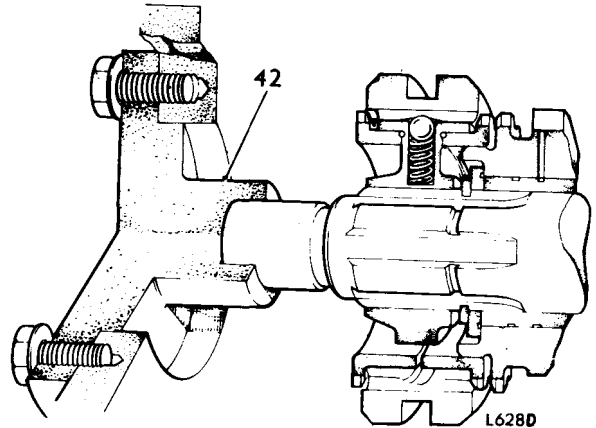

52. Refit the retaining plate, secure with cross recessed head screw.
- \*\* 53. Apply jointing compound to the front cover plate gasket, fit the plate and secure with two screws and copper washers. \*\*
54. Refit the mainshaft rear thrust washer and locate the rear extension and gasket (if overdrive is to be fitted refit the adaptor plate and cam and continue from 59).
55. Secure the rear extension, six bolts.
56. Refit the drive flange.
57. Fit the washer and tighten the nut to a torque load of 90 to 110 lbf ft (12.4 to 15.2 kgf m) using tool No. R421 to retain the flange.
58. Refit the speedometer drive pinion assembly and secure with the peg bolt.
59. Refit the front bearing plate and gasket – 4 setscrews.
60. Refit the clutch release mechanism 33.25.12.
61. Refit the top cover assembly and gasket – secure with eight bolts.
62. Refit the gearbox.

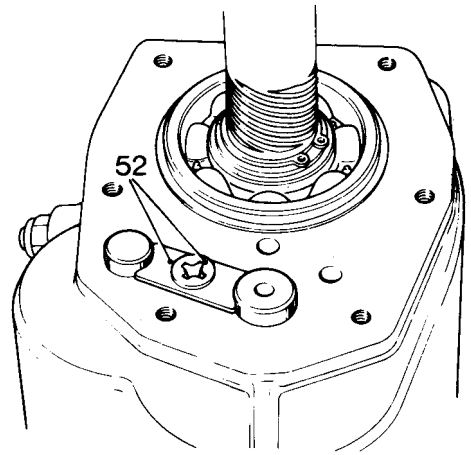

NT2888B

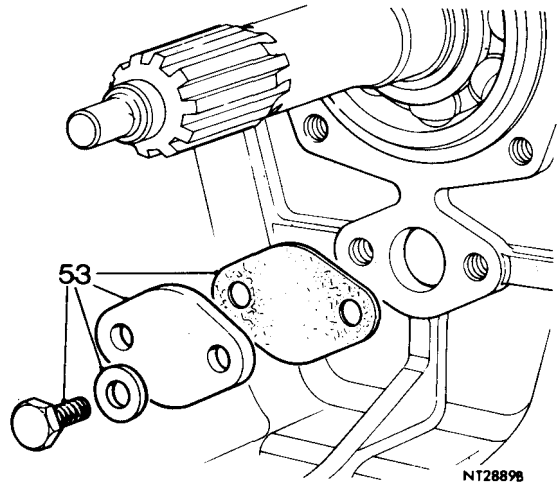

NT2889B

# SYNCHROMESH GEARBOX

## SYNCHRO UNITS

– Overhaul

37.20.08

1. Remove the synchro units 37.20.04 (1 – 23).

### Dismantling

2. Within the walls of a small box to prevent loss of components, carefully push the synchro hub through the sleeve.
3. Collect the three steel balls and springs.

### Reassembling

4. Trial fit the sleeve to the hub. The fit should be free sliding.
5. Assemble three springs and steel balls to the hub.
6. Fit the sleeve.
7. Test, using a spring balance. The axial release load which should be:
  - 1st/2nd – 21 to 26 lbs (10.1 to 12.5 kg)
  - 3rd/top – 14 to 19 lbs (6.7 to 9.1 kg)If the release loads are below these limits, use new springs. If above, grind down the springs.
8. Refit the synchro units 37.20.04 (39 – 62).

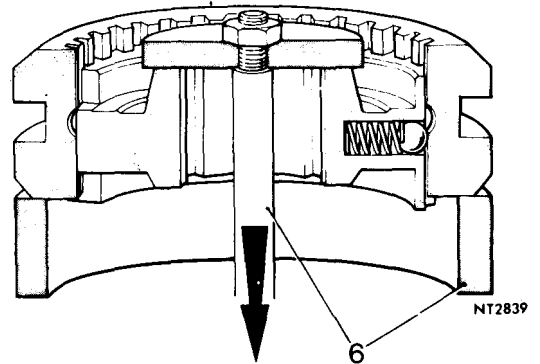
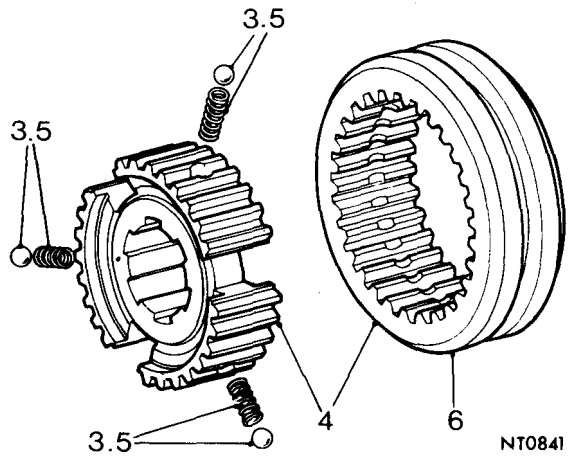

COUNTERSHAFT CLUSTER

– Overhaul

37.20.29

1. Remove the countershaft cluster 37.20.04 (1 – 23, 28 – 30).

Dismantling

2. Separate the 4th constant gear, spacer, 3rd and 2nd constant gears from the hub.
3. Remove the circlip.
4. Extract the roller bearings and backing washers from the hub.

Reassembling

5. Refit the backing washers and roller bearings.
6. Refit the circlips.
7. Assemble the 2nd and 3rd constant gears, spacer and 4th constant gear to the hub.
8. Refit the countershaft cluster 37.20.04 (32 – 62).

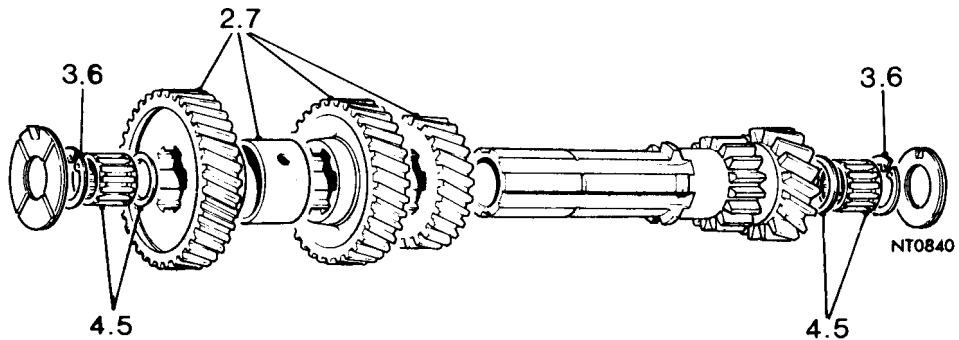

# SYNCHROMESH GEARBOX

## CONSTANT PINION ASSEMBLY

– Overhaul

37.20.54

– Service tool S4221A – 15A.

1. Remove the constant pinion assembly 37.20.04 (1 – 18).

### Dismantling

2. Remove the mainshaft spigot bearing.
3. Remove the circlip and washer.
4. Remove the snap ring.
5. Using tool No. S4221A-15A, withdraw the bearing.
6. Remove the oil thrower.

### Reassembling

7. Fit the oil thrower over the shaft.
8. Using tool No. S4221A-15A fit the bearing ensuring that the oil thrower is centralised.
9. Fit the washer and a new circlip.
10. Refit the snap ring.
11. Refit the mainshaft spigot bearing.
12. Refit the constant pinion assembly 37.20.04 (48 – 62).

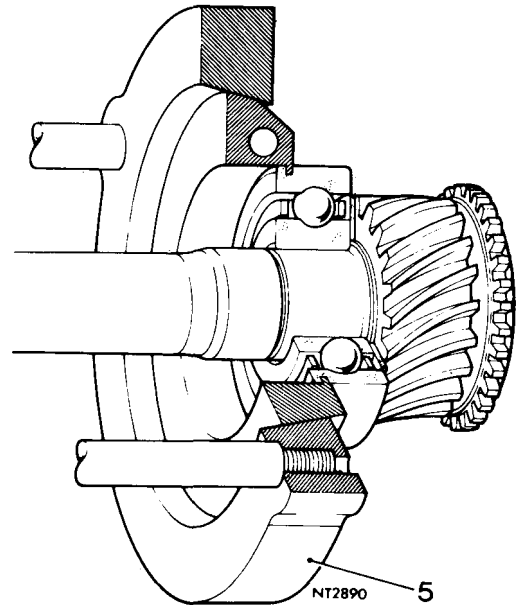
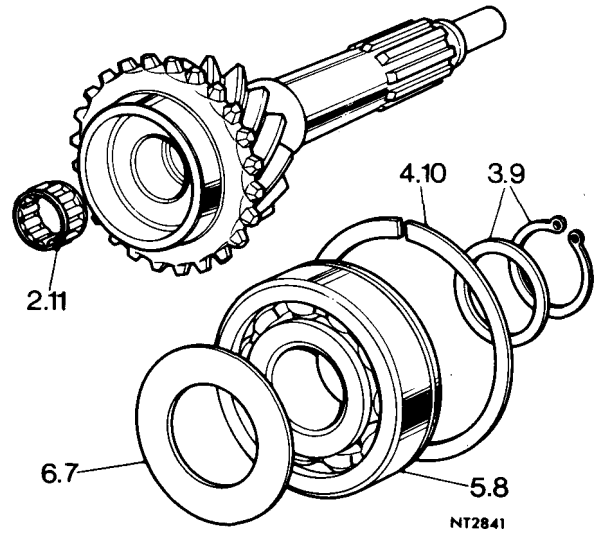

**REAR OIL SEAL**

Service tool RG.421

– Remove and refit **37.23.01.**

**Removing**

1. Drive the vehicle onto a ramp.
2. Remove the exhaust silencer and tail pipes and intermediate pipes 30.10.11 and 12.14.24-25.
3. Remove the propeller shaft 47.15.01.
4. Using tool No. RG.421 to retain the flange, unscrew and remove the nut.
5. Remove the drive flange.
6. Prise out the seal.

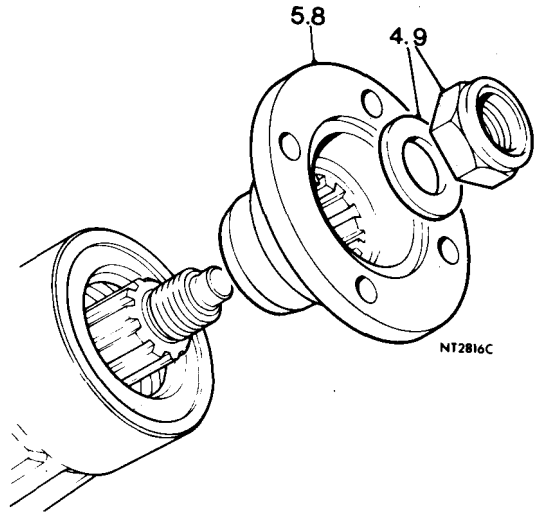

**Refitting**

7. Fit a new seal into the rear extension.
8. Refit the flange.
9. Using tool No. RG.421 to retain the flange, fit and tighten the nut to a torque load of 90 to 110 lbf ft (12.4 to 15.2 kgf m).
10. Refit the propeller shaft 47.15.01
11. Refit the exhaust intermediate pipes, silencer and tail pipes 30.10.11 and 12.14.24-25.

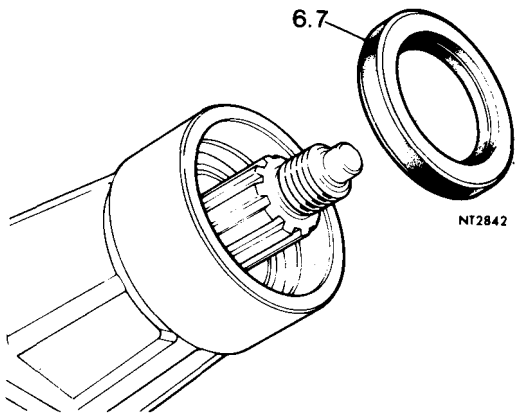

**FRONT OIL SEAL**

– Remove and refit **37.23.06**

**Removing**

1. Remove the gearbox 37.20.01.
2. Remove the clutch release mechanism 33.25.12.
3. Suitably mask the constant pinion shaft splines.
4. Remove the front bearing plate – four setscrews.
5. Prise out the oil seal.

**Refitting**

6. Press a new oil seal into the bearing plate.
7. Apply grease to the cover abutment face and fit the gasket.
8. With the constant pinion shaft splines covered (see 3), fit the front end cover - four setscrews and plain washers.
9. Remove the cover from constant pinion shaft splines.
10. Refit the clutch release mechanism 33.25.12.
11. Refit the gearbox 37.20.01.

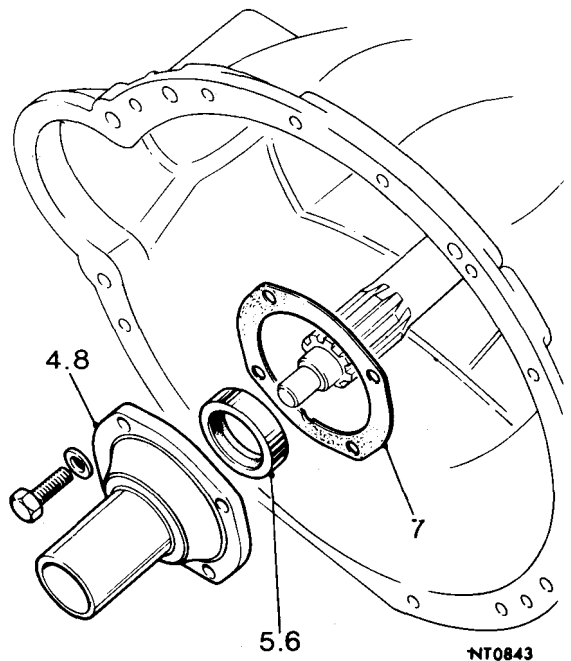

# SYNCHROMESH GEARBOX

## SPEEDOMETER DRIVE PINION ASSEMBLY

– Remove and refit

37.25.09

### Removing

1. Drive the vehicle onto a ramp and raise the ramp.
2. Disconnect the speedometer cable from the gearbox.
3. Unscrew the peg bolt.
4. Withdraw the pinion assembly.

### Refitting

5. Refit the pinion assembly.
6. Locate and tighten the peg bolt.
7. Connect the speedometer cable to the gearbox.

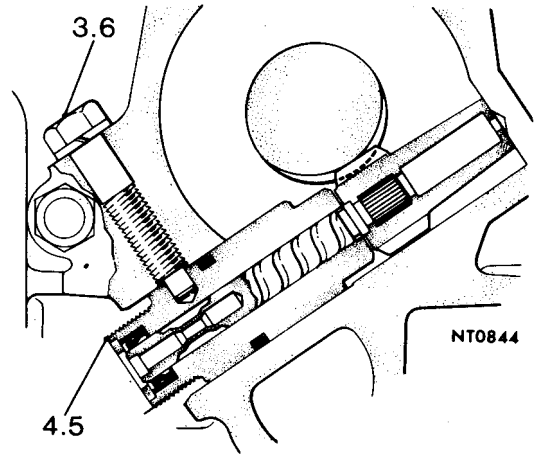

## SPEEDOMETER DRIVE PINION ASSEMBLY

– Overhaul

37.25.13

1. Remove the speedometer pinion assembly 37.25.09.

### Dismantling

2. Withdraw the pinion from the housing.
3. Remove the 'O' ring.
4. Extract the oil seal.

### Reassembling

5. Press a new oil seal into the housing.
6. Refit the 'O' ring.
7. Refit the pinion.
8. Refit the pinion assembly 37.25.09.

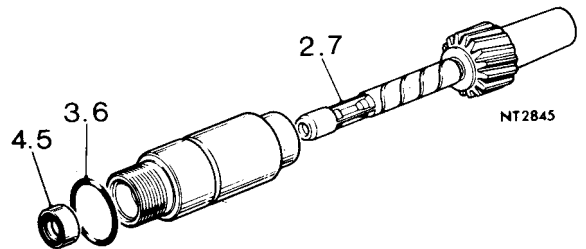

OVERDRIVE OPERATIONS 'A' TYPE

Isolator switch -- remove and refit . . . . .	40.24.04
Oil pump -- remove and refit . . . . .	40.18.01
Overdrive assembly	
-- hydraulic pressure test . . . . .	40.20.01
-- overhaul . . . . .	40.20.10
-- remove and refit . . . . .	40.20.07
Rear oil seal -- remove and refit . . . . .	40.15.01
Selector switch -- remove and refit . . . . .	40.24.01
Solenoid .	
-- remove and refit . . . . .	40.22.04
-- remove, refit and adjust operating valve . . . . .	40.22.05
-- test and adjust . . . . .	40.22.01
Sump filter -- remove and refit . . . . .	40.10.01
Valves	
-- operating valve, remove, re-seat and refit . . . . .	40.16.01
-- non-return valve, remove, re-seat and refit . . . . .	40.16.10

NOTE: The A type overdrive is fitted only to cars with the commission number prefix CP or CC.





**OVERDRIVE 'A' TYPE**

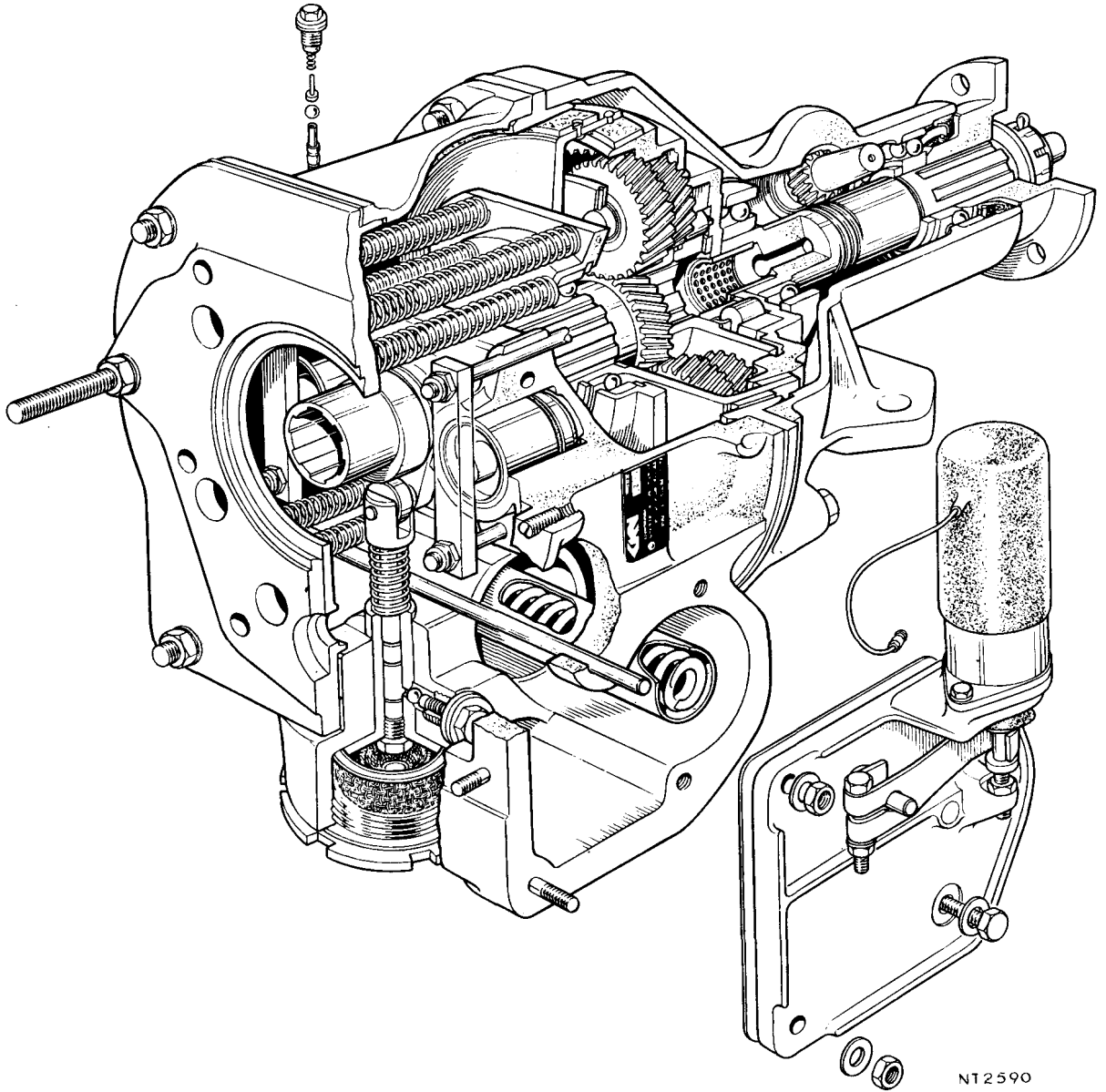

FAULT DIAGNOSIS AND RECTIFICATION

Fault	Possible Cause	Remedy
OVERDRIVE DOES NOT ENGAGE	a. Insufficient oil in unit	Top up gearbox/overdrive
	b. Solenoid not energizing	Check circuit
	c. Solenoid energized – not operating	Test and adjust. 40.22.01
	d. Insufficient hydraulic pressure due to pump non-return valve not seating	Re-seat valve. 40.16.10
	e. Insufficient hydraulic pressure due to worn accumulator	Overhaul unit. 40.20.10
	f. Choked filter	Clean filter. 40.10.01
	g. Pump damaged	Remove and check. 40.18.01
	h. Operating valve leaking	Re-seat valve. 40.16.01
	i. Internal damage	Overhaul unit. 40.20.10
	*OVERDRIVE DOES NOT RELEASE	a. Fault in electrical control circuit
b. Choked jet in operating valve		Check valve. 40.16.01
c. Solenoid/lever incorrect		Test and adjust. 40.22.01
d. Sticking clutch		See note †
e. Internal damage		Overhaul unit. 40.20.10
CLUTCH SLIP IN OVERDRIVE	a. Insufficient oil in unit	Top up gearbox/overdrive
	b. Solenoid lever out of adjustment	Adjust. 40.22.01
	c. Insufficient oil pressure due to pump non-return valve not seating	Re-seat valve. 40.16.10
	d. Insufficient oil pressure due to worn accumulator	Overhaul unit. 40.20.10
CLUTCH SLIP IN REVERSE AND FREE-WHEEL ON OVER-RUN	a. Solenoid lever out of adjustment	Adjust. 40.22.01
	b. Partially choked restrictor jet in operating valve.	Check valve. 40.16.01
	c. Solenoid stop incorrectly set	Adjust. 40.22.01

\*CAUTION: If, for any reason, the overdrive cannot be released do not reverse the vehicle as severe internal damage will result.

† NOTE: When a clutch is sticking on a new vehicle the probable cause is the linings not having bedded in sufficiently to release. Where this occurs the linings may usually be parted by striking the brake ring sharply with a hide mallet.

DATA

Clutch movement from direct to overdrive	0.110 to 0.120 in
Hydraulic operating pressure	410 to 430 lb/in <sup>2</sup>
Ratio	22%



## OVERDRIVE 'A' TYPE

\*\*

**SUMP FILTER (Laycock unit type 22/61753 – see identification plate)**

– Remove and refit **40.10.01**

### Removing

1. Raise car on ramp.
2. Place a container to receive oil.
3. Remove guard and drain plug.
4. Lift out filter.
5. Clean filter and plug.

### Refitting

6. Insert filter.
7. Fit drain plug with magnetic washers and new sealing washer.
8. Fit drain plug guard.
9. Top up gearbox/overdrive oil level.
10. Lower vehicle.

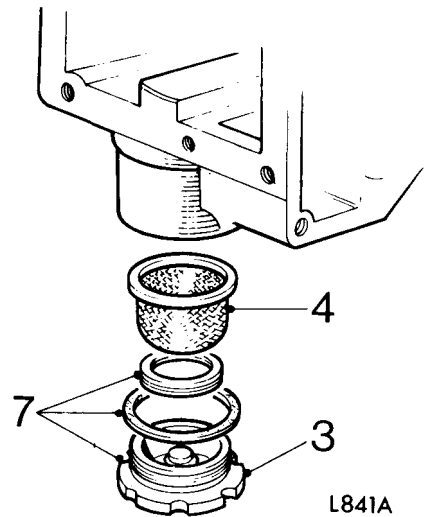

**SUMP FILTER (Laycock unit type 22/61985 – see identification plate)**

– Remove and refit **40.10.01**

### Removing

1. Raise car on the ramp.
2. Place a container to receive the oil under the overdrive.
3. Remove the drain plug.
4. Lift out the filter.
5. Clean the filter, plug and magnetic rings.

### Refitting

6. Insert the filter.
7. Fit the drain plug with magnetic washers and new sealing washer.
8. Top up gearbox/overdrive oil level.
9. Lower the vehicle.

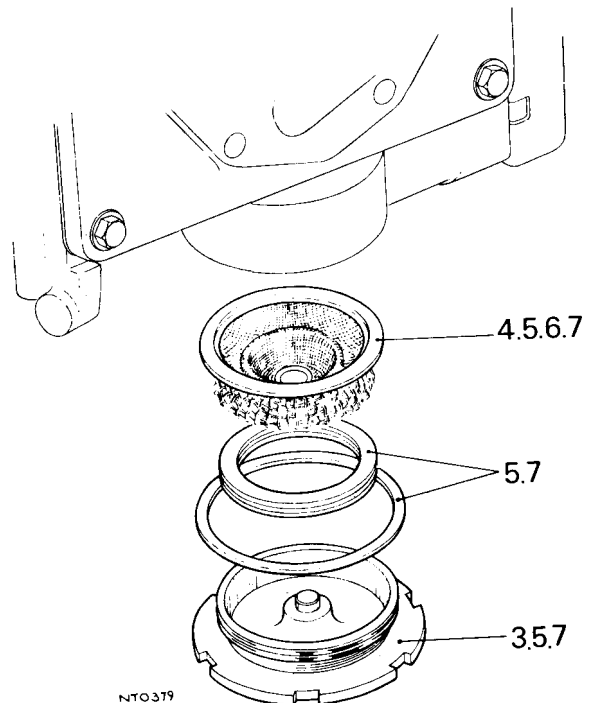

\*\*

**REAR OIL SEAL**

– Remove and refit

40.15.01

Service tool: L177A

**Removing**

1. Raise vehicle.
2. Remove propeller shaft. 47.15.01.
3. Remove split pin, nut, washer and drive flange.
4. Prise out oil seal.

**Refitting**

5. Fit oil seal squarely into position with lip facing inboard and abutting against shoulder in case tool L177A.
6. Fit drive flange, washer and nut, tightening to 90 to 110 lbf ft (12.4 to 15.2 kgf m). Secure with split pin.
7. Fit propeller shaft. 47.15.01.
8. Lower vehicle.

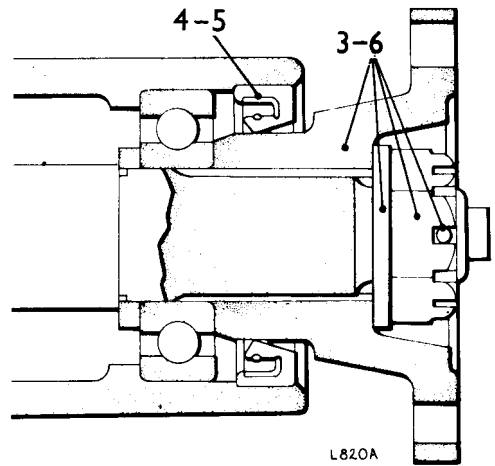

**OPERATING VALVE**

– Remove and refit

40.16.01

**Removing**

1. Switch ignition ON, engage top gear, operate overdrive switch six times, switch off. This operation dissipates pressure in overdrive unit.
2. Lift front console tray, remove rubber grommet.
3. Use extension and socket to remove operating valve plug.
4. Use magnet to withdraw spring, plunger, ball and valve.
5. Insert ball into hole and onto its seal. Fit valve upside down so that the seat in the casing is facing the seat on the valve with the ball interposed.
6. Give the valve a sharp, gentle tap, remove the valve and ball.
7. Check the valve bore and outlet hole to ensure it is not choked.

**Refitting**

8. Reverse 1 to 4.

**NON-RETURN VALVE**

– Remove, re-seat and refit

40.16.10

Operation 40.18.01, 1 to 9 and 21 to 33.

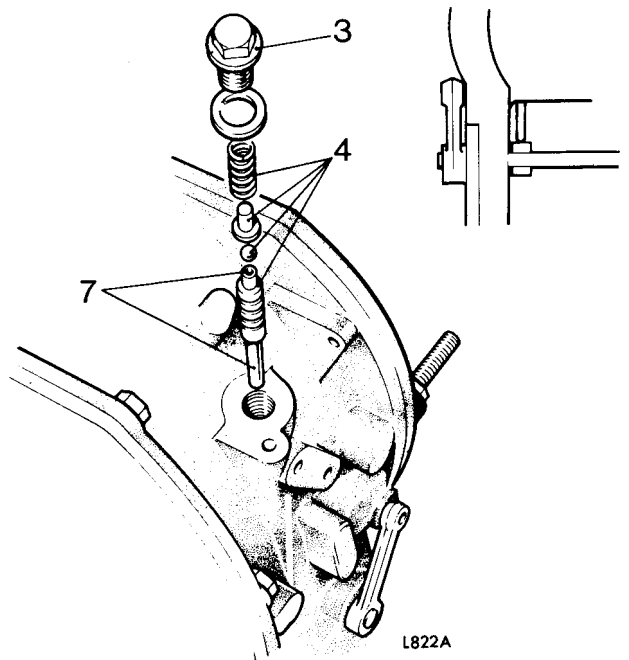

# OVERDRIVE 'A' TYPE

## OIL PUMP

– Remove and refit

40.18.01

Service tools: L183A, L183A1, L183A2, L184

### Removing

1. Raise vehicle, drain oil from overdrive.
2. Remove two screws securing solenoid to bracket.
3. Withdraw solenoid and plunger.
4. Slacken clamp bolt, withdraw operating fork and spacer.
5. Remove two nuts on solenoid bracket studs.
6. Progressively unscrew two bolts, with red painted heads, securing solenoid bracket.  
**WARNING: To avoid personal injury remove nuts (5) before bolts (6) to enable the greater length of the bolts to progressively relieve the tension of the accumulator spring.**
7. Remove solenoid bracket, collect 'O' ring from bracket recess or operating lever cross-rod.
8. Remove non-return valve plug.
9. Withdraw non-return valve spring, plunger and ball.
10. Remove sump filter.
11. Remove hexagon plug and two screws.
12. Fit tool L183A1 to pump and withdraw pump body, spring and piston.

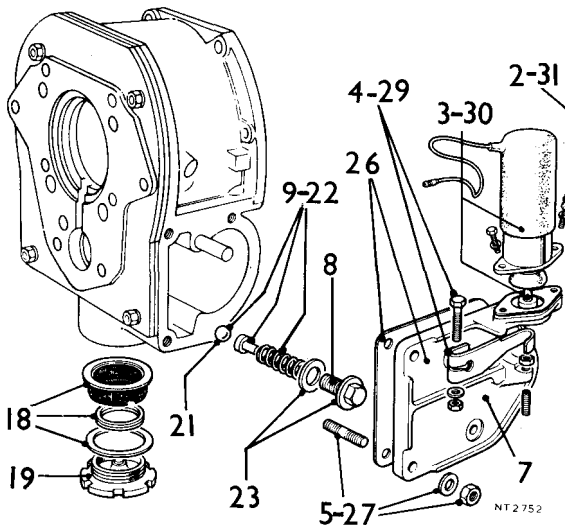

### Refitting

13. Fit guide pegs into bottom pump face holes.
14. Assemble plunger, spring and pump body.
15. Insert pump assembly over guide pegs with:  
(a) Flat on plunger facing to the rear.  
(b) Hole in pump body flange adjacent to hole in casing.
16. Drift pump into position. Tool L184.
17. Remove guide pegs, fit two screws and hexagon plug.
18. Fit sealing washers, magnetic washers and filter to drain plug.
19. Fit and tighten drain plug.
20. Fit drain plug guard.
21. Fit non-return valve ball on seat and tap with copper drift to seat ball.
22. Fit valve components' ball, plunger and spring.
23. Fit plug and sealing washer.
24. Check that accumulator spring and shims (where fitted) are in position.
25. Fit 'O' ring to solenoid bracket recess.
26. Fit solenoid bracket and gasket.
27. Fit and evenly tighten the two red-headed screws.
28. Fit and tighten two nuts.
29. Fit spacer and solenoid operating lever.
30. Fit solenoid, inserting plunger in yoke of operating lever.
31. Fit and tighten two solenoid retaining screws.
32. Test and adjust solenoid. 40.22.01.
33. Top up gearbox and overdrive oil level, run vehicle and re-check oil level.

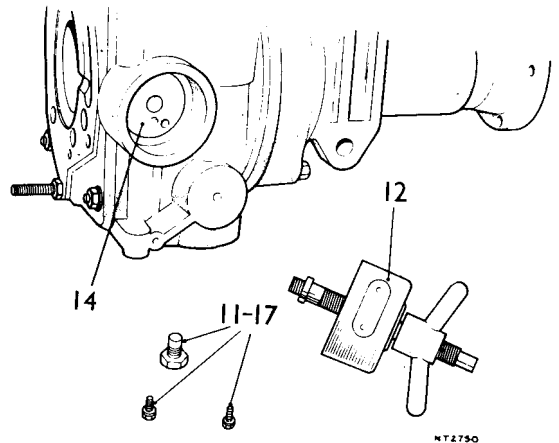

**OPERATING VALVE**

– Remove and refit

40.16.01

**Removing**

1. Switch ignition ON, engage top gear, operate overdrive switch six times, switch off. This operation dissipates pressure in overdrive unit.
2. Lift front console tray, remove rubber grommet.
3. Use extension and socket to remove operating valve plug.
4. Use magnet to withdraw spring, plunger, ball and valve.
5. Insert ball into hole and onto its seat. Fit valve upside down so that the seat in the casing is facing the seat on the valve with the ball interposed.
6. Give the valve a sharp, gentle tap, remove the valve and ball.
7. Check the valve bore and outlet hole to ensure it is not choked.

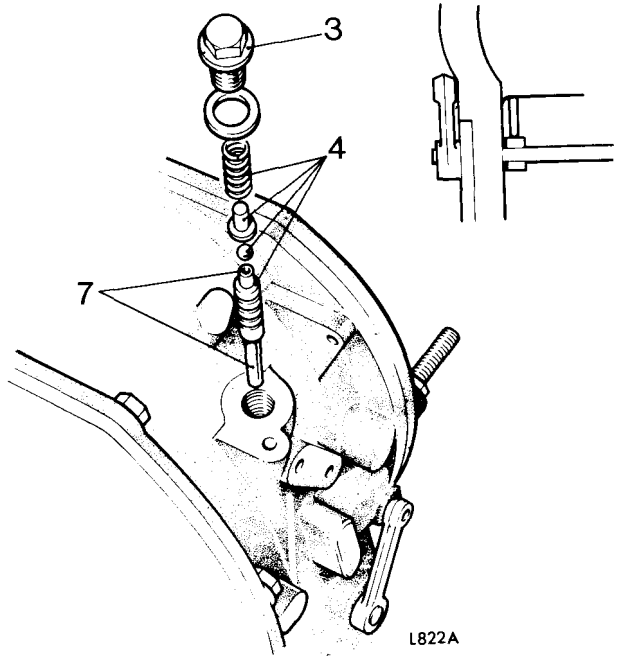

L822A

**Refitting**

8. Reverse 1 to 4.

**NON-RETURN VALVE**

– Remove, re-seat and refit

40.16.10

Operation 40.18.01, 1 to 9 and 21 to 33.

# OVERDRIVE 'A' TYPE

## OIL PUMP

– Remove and refit

40.18.01

Service tools: L183A, L183A1, L183A2, L184

### Removing

1. Raise vehicle, drain oil from overdrive.
2. Remove two screws securing solenoid to bracket.
3. Withdraw solenoid and plunger.
4. Slacken clamp bolt, withdraw operating fork and spacer.
5. Remove two nuts on solenoid bracket studs.
6. Progressively unscrew two bolts, with red painted heads, securing solenoid bracket.  
**WARNING: To avoid personal injury remove nuts (5) before bolts (6) to enable the greater length of the bolts to progressively relieve the tension of the accumulator spring.**
7. Remove solenoid bracket, collect 'O' ring from bracket recess or operating lever cross-rod.
8. Remove non-return valve plug.
9. Withdraw non-return valve spring, plunger and ball.
10. Remove sump filter.
11. Remove hexagon plug and two screws.
12. Fit tool L183A1 to pump and withdraw pump body, spring and piston.

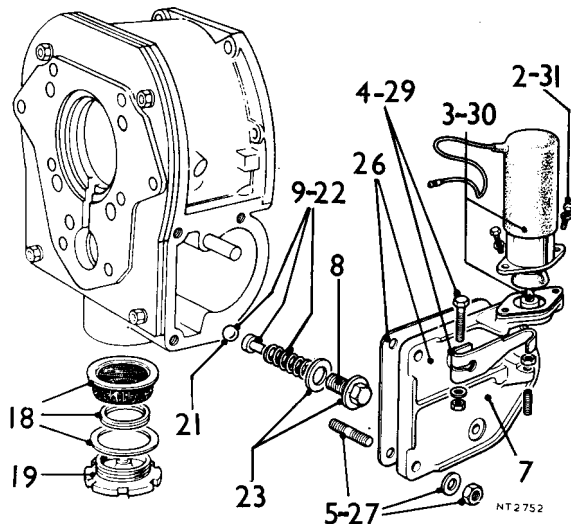

### Refitting

13. Fit guide pegs into bottom pump face holes.
14. Assemble plunger, spring and pump body.
15. Insert pump assembly over guide pegs with:  
(a) Flat on plunger facing to the rear.  
(b) Hole in pump body flange adjacent to hole in casing.
16. Drift pump into position. Tool L184.
17. Remove guide pegs, fit two screws and hexagon plug.
18. Fit sealing washers, magnetic washers and filter to drain plug.
19. Fit and tighten drain plug.
20. Fit drain plug guard.
21. Fit non-return valve ball on seat and tap with copper drift to seat ball.
22. Fit valve components: ball, plunger and spring.
23. Fit plug and sealing washer.
24. Check that accumulator spring and shims (where fitted) are in position.
25. Fit 'O' ring to solenoid bracket recess.
26. Fit solenoid bracket and gasket.
27. Fit and evenly tighten the two red-headed screws.
28. Fit and tighten two nuts.
29. Fit spacer and solenoid operating lever.
30. Fit solenoid, inserting plunger in yoke of operating lever.
31. Fit and tighten two solenoid retaining screws.
32. Test and adjust solenoid. 40.22.01.
33. Top up gearbox and overdrive oil level, run vehicle and re-check oil level.

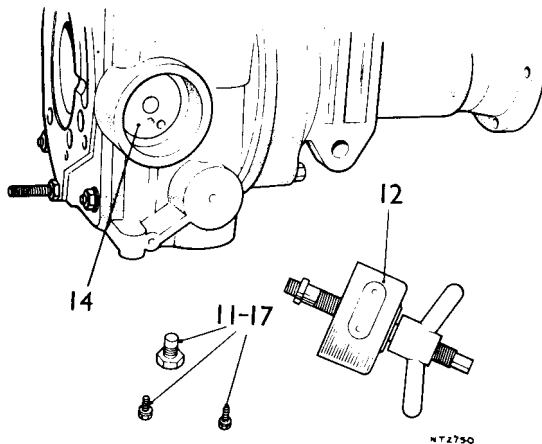

## OVERDRIVE ASSEMBLY

## — Hydraulic pressure test

40.20.01

Service tool: L188

1. Remove the gearbox tunnel cover — 17.01
2. Switch ignition ON, top gear, overdrive IN and OUT six times.
3. Use socket and extension to remove operating valve plug.
4. Fit hydraulic test gauge tool L188 to operating valve orifice.
5. Road-test or jack up vehicle and run engine with ans without overdrive.
6. Note the gauge reading which should be 410 to 430 lb/in<sup>2</sup>.
7. Switch engine off, ignition on, top gear, overdrive in and out six times to dissipate oil pressure.
8. Remove gauge, refit operating valve plug.
9. Fit rubber grommet and front console tray.

**NOTE:** Lack of oil pressure when overdrive selected may indicate a fault in the pump non-return valve. 40.16.10.

Lack of oil pressure when overdrive not selected may indicate a fault in the operating valve. 40.16.01.

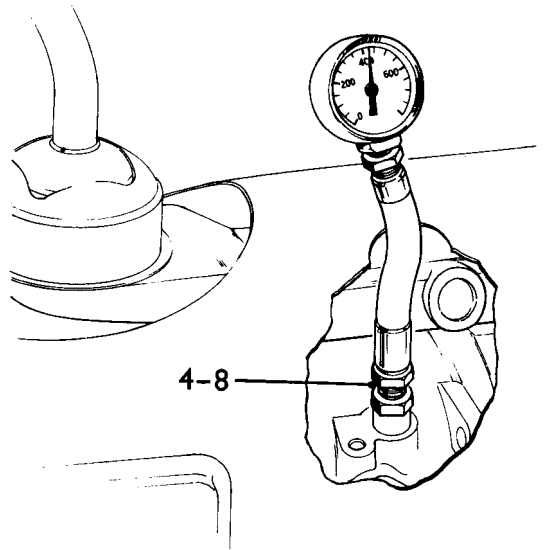

NT 2 870



# OVERDRIVE 'A' TYPE

## OVERDRIVE ASSEMBLY

– Remove and refit

40.20.07

### Removing

1. Remove gearbox. 37.20.01.
2. Drain gearbox and overdrive units of oil.
3. Place gearbox, bell housing flange down on bench.
4. Remove four nuts on *short* studs securing overdrive to gearbox.
5. Remove, evenly, the nuts on long studs securing overdrive to gearbox.
6. Lift off overdrive unit, collect eight overdrive clutch return springs.

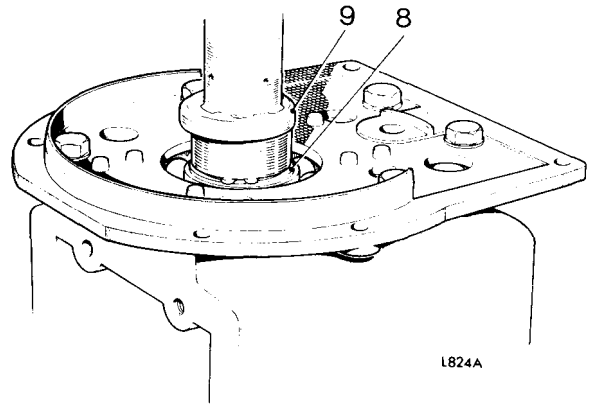

### Refitting

7. Use a dummy mainshaft to ensure that the splines on the uni-directional clutch and the planet carrier are aligned.
8. Check that pump cam is fitted to mainshaft with long, plain end towards the gearbox.
9. Rotate mainshaft until narrowest part of cam is towards bottom of gearbox.
10. Thread a length of soft iron wire through the pump plunger and form it into a continuous loop just below sump level.

**NOTE:** The plunger of the oil pump must be depressed whilst fitting the overdrive to allow it to come up below the drive cam when fitted.

*Continued*

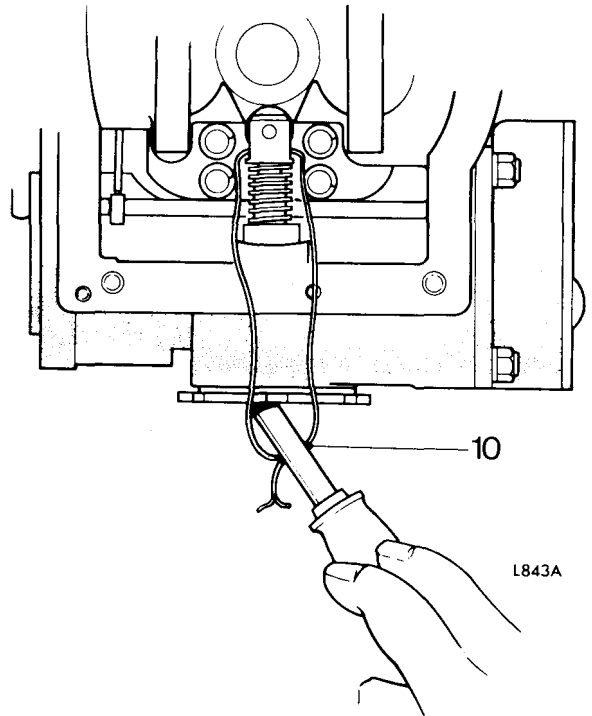

11. Fit gasket to adaptor plate.
12. Remove dummy mainshaft and position overdrive over mainshaft with the two long studs slightly misaligned to hold overdrive and gearbox apart.
13. Fit clutch return springs into position with shorter springs on inner posts and locating all springs on their posts and resting over bosses on adaptor plate.
14. Line up long studs and lower overdrive into position, turning drive flange to line up splines of mainshaft and planet carrier/uni-directional clutch.

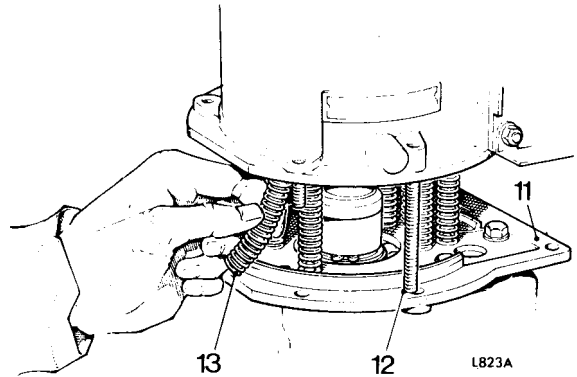

15. Fit nuts and washers to two long studs and evenly tighten whilst using a screwdriver through the loop of wire to depress pump plunger.  
**CAUTION:** Locking of the unit before it is tightened down indicates either (a) splines not aligned correctly or (b) cam and pump fouling. Do not try to force units together but slacken off, investigate cause, rectify and repeat.
16. When the faces are 0.20 in (5 mm) apart cut wire loop and pull out carefully ensuring that all of the wire is removed.
17. Tighten nuts, fit and tighten remaining nuts and washers.
18. Refit gearbox. 37.20.01.

# OVERDRIVE 'A' TYPE

## OVERDRIVE ASSEMBLY

— Overhaul

40.20.10

Service tools: L178, L182, L183A, L183A1, L183A2, L184, L185A, L188, L190A

**CAUTION:** The internal working parts and oil ways are particularly vulnerable to dirt: for this reason it is most important that a clinical standard of cleanliness is maintained throughout the following operation.

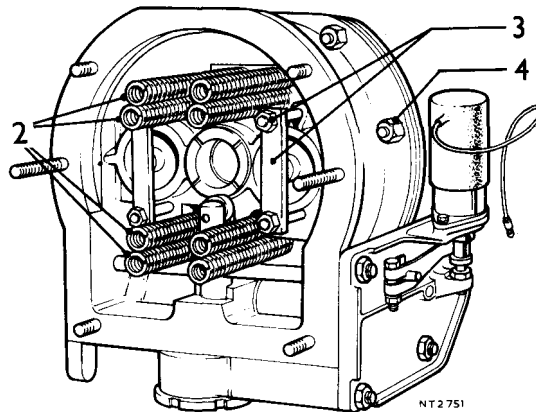

## Dismantling

1. Remove the overdrive assembly. 40.20.07.
2. Remove eight clutch return springs.
3. Release lock washers, unscrew four nuts and remove the two bridge pieces.
4. Remove six nuts securing front to rear casings.
5. Separate casings and brake ring.

**CAUTION:** The use of a lever or screwdriver to separate the casings will damage the mating faces and result in oil leakage, Use a hide hammer to cases that are tight.

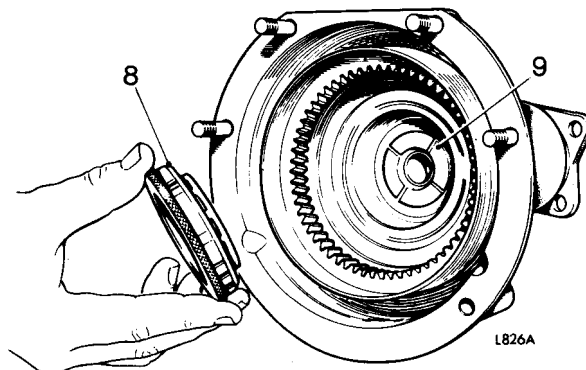

## Rear casing

6. Withdraw clutch sliding member.
7. Remove sun wheel and planet carrier.
8. Cover the uni-directional clutch with tool L178 and draw the clutch into the tool with the fingers.
9. Withdraw bronze thrust washer.
10. Remove split pin, nut and washer securing drive flange to tail shaft.
11. Withdraw drive flange.
12. Remove rear oil seal.
13. Remove speedometer drive pinion and housing.
14. Press annulus from rear casing.
15. Remove spacing washer from annulus tail shaft.
16. Remove front bearing from annulus.
17. Drive rear bearing from casing.

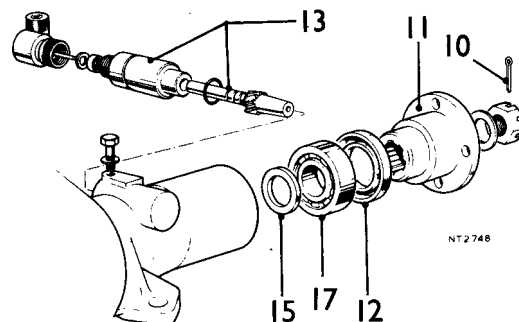

*Continued*

**Clutch sliding member**

18. Remove circlip and carefully separate clutch member and drive ring assembly.
19. Remove circlip and press bearing from drive ring.

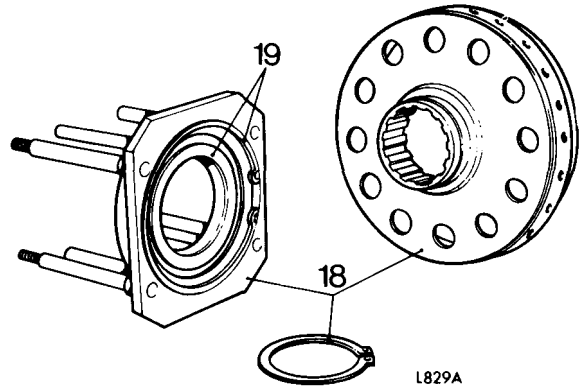

**Front casing**

20. Remove bronze and steel thrust washers.

**Operating valve**

21. Remove operating valve plug a, copper washer b, and withdraw valve components – spring c, plunger d, ball e and valve f.
22. Remove operating pistons using grips and withdrawing with a rotary pull.

**Solenoid**

23. Remove two screws securing solenoid.
24. Remove solenoid, easing plunger from yoke of operating lever.
25. Release clamp bolt and remove operating lever and spacer.
26. Remove two nuts from studs securing solenoid bracket.

**WARNING: Remove the nuts (26) before slackening setscrews (27) as the accumulator spring, under tension, must be slackened progressively to avoid the risk of personal injury.**

27. Progressively slacken the two setscrews with heads painted red securing solenoid bracket to casing.
28. Remove solenoid bracket.
29. Collect 'O' ring from cross-rod or solenoid bracket.

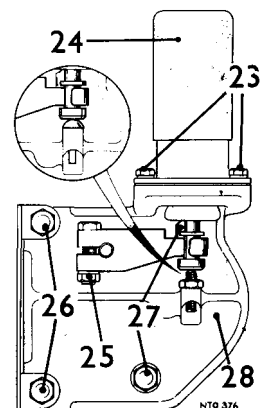

*Continued*

## Accumulator

30. Remove accumulator spring, shim washers and tube.
31. Insert tool L182 into bore of accumulator sleeve, turn lower lever to lock in position, withdraw accumulator by turning and pulling upper lever.
32. Separate sleeve and piston.

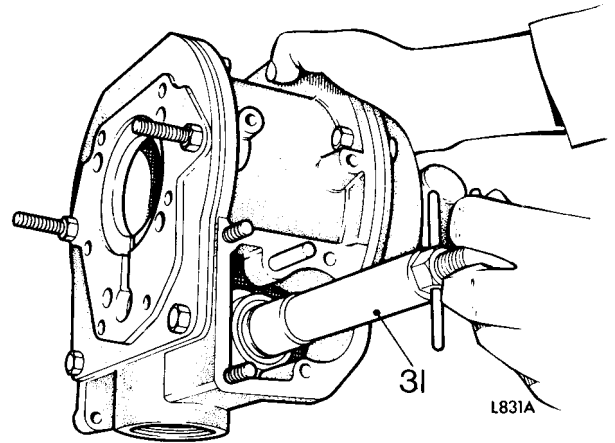

## Non-return valve

33. Remove hexagon plug a, copper washer b and valve components – spring c, plunger d and ball e.

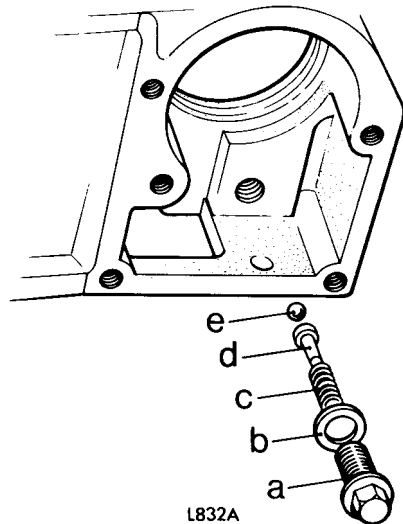

## Pump

34. Remove sump plug, sealing washer and magnetic washers.
35. Remove filter.
36. Remove hexagon plug and two screws.
37. Fit tool L183A1 to pump and withdraw pump body a, spring b and piston c.

## Inspection

38. Clean all components.
39. Inspect all gears, bearings, bushes, working surfaces and oilways for evidence of undue wear and blockage in accordance with good engineering practice. Renew as necessary.
40. Renew all 'O' rings, oil seals and gaskets. Lubricate all 'O' rings with petroleum jelly prior to fitting.

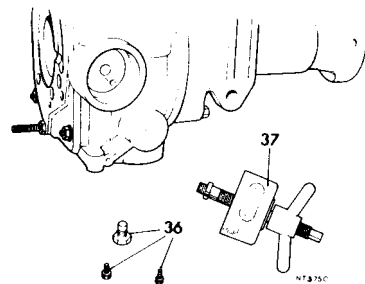

*Continued*

**Reassembly**

**Front casing**

**Pump**

41. Fit guide pegs into holes in bottom pump face.
42. Assemble plunger, spring and pump body.
43. Insert pump assembly over guide pegs with (a) flat on plunger against guide dowel (below centre bronze bush) and (b) hole in pump body flange adjacent to hole in casing.
44. Drift pump into position using L184 (drift).
45. Remove guide pegs, fit two screws and base plug.
46. Fit sealing washer, magnetic washers and filter to drain plug.
47. Fit and tighten drain plug and guard assembly.

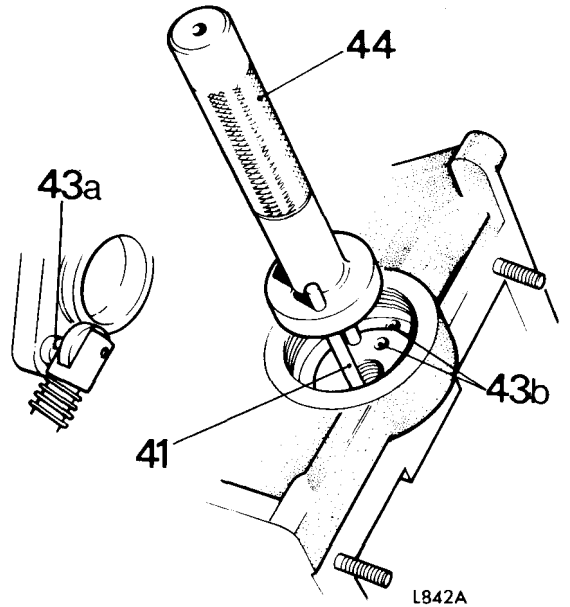

- Non-return valve**
48. Fit ball (0.25 in dia.) on seat and tap with copper drift to seat ball.
  49. Fit valve components – (a) ball (b) plunger, (c) spring.
  50. Fit and tighten copper washer and hexagon plug.

*Continued*

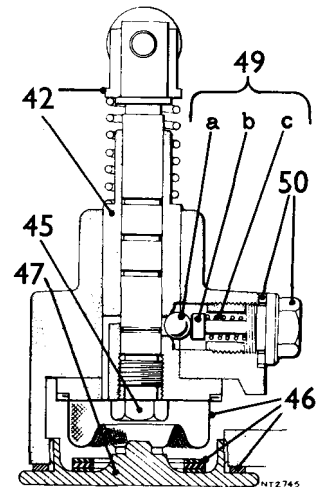

## Accumulator

51. Fit rings to piston – two wide inners, four thin outers.
52. Fit piston to sleeve using tool L179.
53. Fit 'O' ring to sleeve.
54. Ease sleeve into bore and push home using accumulator tube.
55. Fit accumulator spring and shims (where fitted).  
**CAUTION:** When accumulator spring shims are fitted they must be replaced. Fitting washers of greater thickness can cause a pressure build-up where a spring becomes coil-bound and the blow-off holes are not uncovered by the piston.
56. Fit 'O' ring to solenoid bracket recess.
57. Fit solenoid bracket and gasket.
58. Fit and tighten evenly the two red-headed set screws.
59. Fit and tighten nuts and washers.

## Solenoid

60. Fit spacers and solenoid-operating lever, securing with clamp bolt.
  61. Fit solenoid, inserting plunger to yoke of operating lever.
  62. Fit and tighten two solenoid retaining screws.
- NOTE:** when the overdrive is rebuilt the solenoid will require adjustment (40.22.01).

*Continued*

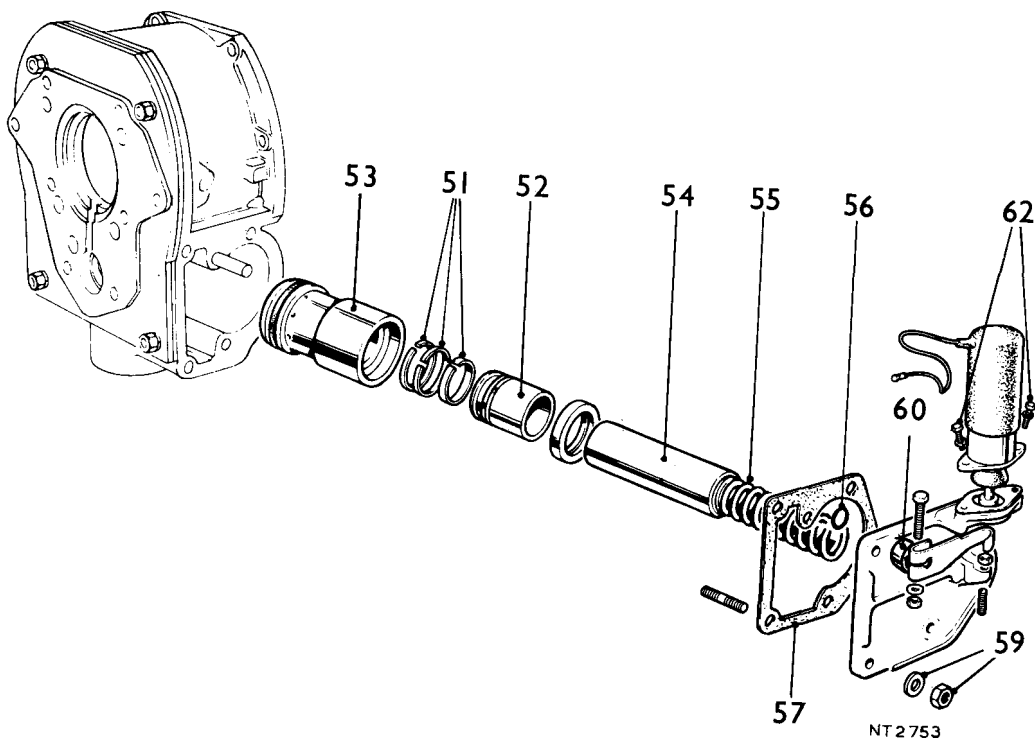

**Operating valve**

63. Insert valve into casing, ensuring that the hemispherical head engages on the flat of the cam on the operating cross-shaft.
64. Drop the 0.3125 in dia. ball (a) on its seat, insert plunger (b) and spring (c).
65. Fit and tighten plug and copper washer.
66. Fit 'O' rings to operating pistons.
67. Fit pistons to bores.

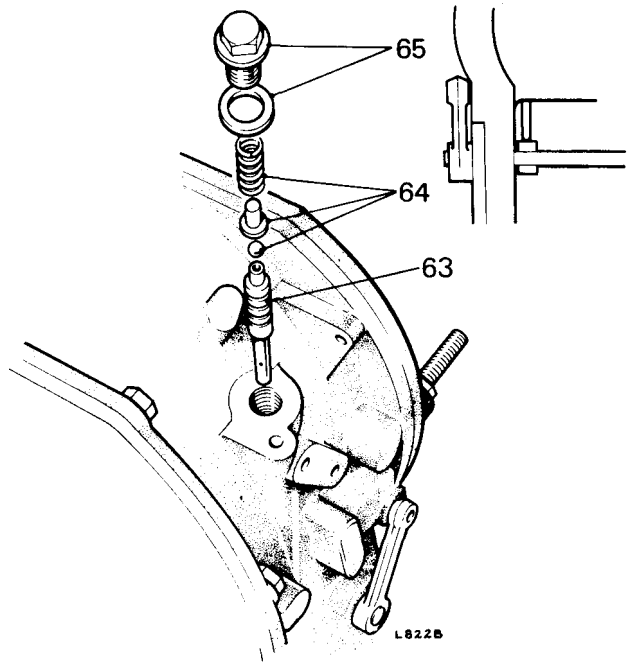

**Rear casing**

68. Press the front bearing into the rear casing until it abuts against the shoulder in the casing.
69. Press the annulus into the front bearing in casing.
70. Fit gauge L190A over the tailshaft until the outer member contacts the rear bearing shoulder in the casing.
71. Press down the inner member (L190A) and select a spacing washer which will just fit in slot in gauge.  
**NOTE:** Spacing washers are available as follows:  
Part No. 500623 suffix E 0.146 in; F 0.151 in; G 0.156 in; J 0.166 in.
72. Remove gauge, fit selected washer.
73. Drive rear bearing into position.
74. Fit rear oil seal squarely until it abuts on casing shoulder.
75. Fit rear drive flange, washer, nut and split pin.

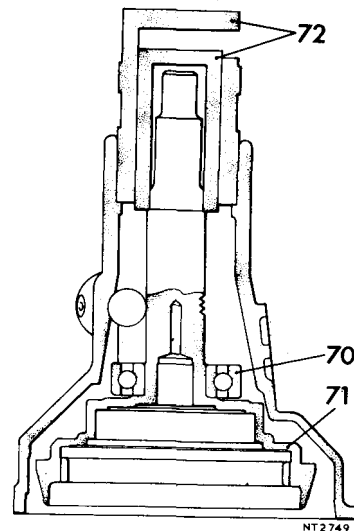

*Continued*



**Un-directional clutch**

- 76. Assembly spring into roller cage.
- 77. Fit inner member and engage on other end of spring.
- 78. Engage the slots of the inner member with the tongues of the cage so that the spring rotates the cage and rollers (when fitted) up the inclined face of the inner member.
- 79. Place assembly, front end down, into tool L178 and insert rollers through slot in tool, turning clutch clockwise until all rollers are in place.
- 80. Fit thrust washer into annulus recess.
- 81. Fit uni-directional clutch and tool to annulus, slide clutch from tool into its outer bearing in annulus, remove tool.

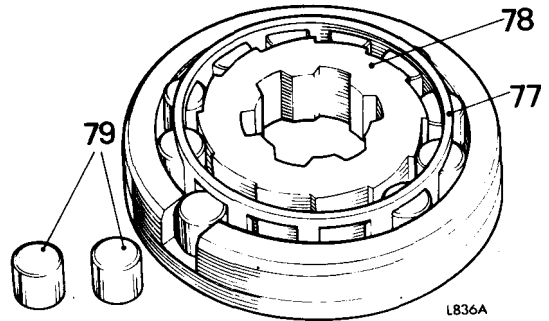

**Planet carrier**

- 82. Rotate each of the three planet gears until a spot, punched on the outside of each gear, is positioned radially outwards.
- 83. Insert sun wheel, meshing with planets and keeping dots in position.
- 84. Insert planet carrier and sun wheel into annulus, meshing gears whilst so doing.

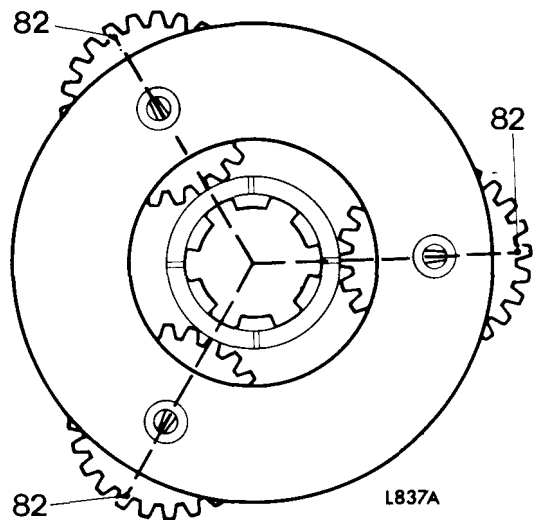

*Continued*



**Sun wheel end-float**

- 85. Insert dummy mainshaft tool L185A and turn sun wheel until shaft engages the planet carrier and uni-directional clutch splines.
- 86. Fit a thrust washer of known thickness plus steel and bronze thrust washers over dummy shaft until they rest on sun wheel.

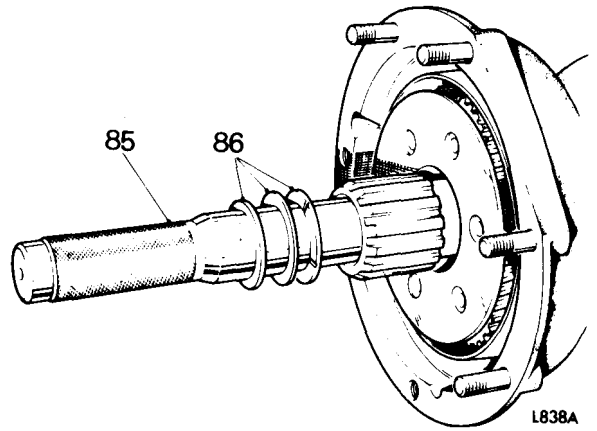

- 87. Fit brake ring to front casing, tap fully home.
- 88. Fit front casing to rear until abutted on washers on dummy shaft.
- 89. Use feeler gauges to measure gap between cases which should be the thickness of the additional washer fitted at 86 minus the required end-float 0.008 to 0.014 in (0.20 to 0.35 mm).

Example (a):

Noted thickness of additional washer	0.125 in
Gap between flanges	0.114 in
End-float	0.011 in

As this end-float is within limits the existing washers are satisfactory.

Example (b):

Noted thickness of additional washer	0.125 in
Gap between flanges	0.123 in
End-float	0.002 in

In this example 0.002 in end-float is not sufficient and a steel washer 0.006 to 0.012 in thicker than the existing washer must be fitted.

Washers are available in the following thicknesses in inches:

Part No. 500588 Suffix A. 0.113 to 0.114; B. 0.107 to 0.108; C. 0.101 to 0.102; D. 0.095 to 0.096; E. 0.089 to 0.090; F. 0.083 to 0.084; G. 0.077 to 0.078.

- 90. On selection of correct washer, separate casings.

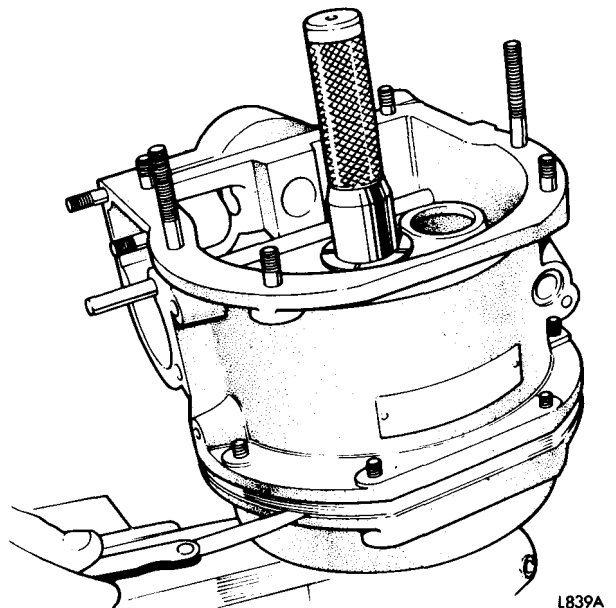

*Continued*



## Clutch sliding member

91. Press bearing evenly into thrust ring, secure with circlip.
92. Press thrust ring assembly on the hub of clutch sliding member, secure with circlip.
93. Fit sliding member assembly engaging with splines of sun wheel.

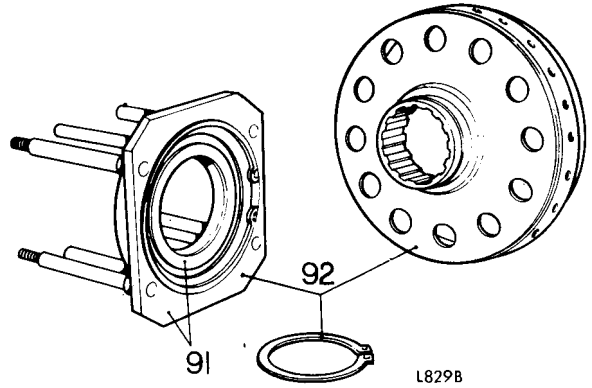

## Re-assemble casings

94. Coat flanges of brake ring with jointing compound and fit to front case.
95. Fit steel washer, selected at 89, then bronze washer into recess in front case; use a smear of grease to retain them in position.
96. Join the front to rear case locating thrust ring posts through holes in front case, ensure thrust washers (95) are still located.
97. Fit and tighten nuts securing front to rear case.
98. Fit bridge pieces securing with nuts locked with new tab washers.
99. Fit eight clutch springs, four short ones on inner posts.
100. Fit overdrive assembly to gearbox.40.20.07.

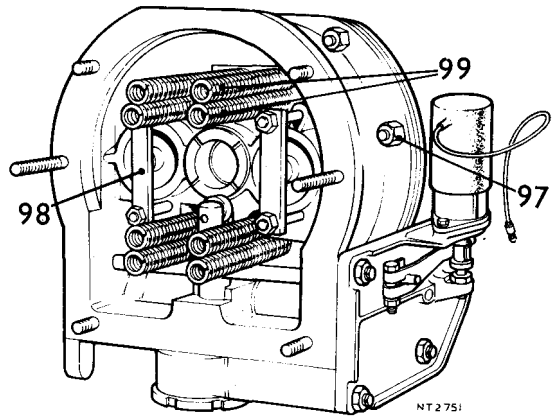

## SOLENOID

– Test and adjust

40.22.01

## Testing

1. Raise vehicle.
2. Connect an ammeter into solenoid feed circuit.
3. Switch ignition ON, top gear, overdrive IN.
4. Note and act on the following accordingly.
  - a. The setting lever will move to a position where its alignment hole is coincident with a hole in the casing (test alignment) by inserting a rod  $3/16''$  dia. through hole in lever and into casing hole). The ammeter will drop to holding current of 1 to 2 amps immediately after switching on. Test satisfactory.
  - b. No current to solenoid – check circuit.
  - c. Setting lever correctly aligned, ammeter reading high – renew solenoid. 40.22.14.
  - d. Setting lever incorrectly aligned, ammeter reading correct/incorrect – adjust operating lever.

## Adjusting operating lever

5. Slacken clamp bolt on operating lever.
6. Check, ignition ON, top gear, overdrive IN.
7. Position rod through hole in setting lever and alignment hole in case. Push plunger into solenoid to its limit, holding lever fork against collar of plunger.
8. Tighten clamp bolt on operating rod.
9. Switch off, re-check 4 till condition 4a exists.
10. Adjust the stop to provide 0.0625 in (1.6 mm) free movement by slackening locknut and turning grub screw with an Allen key.

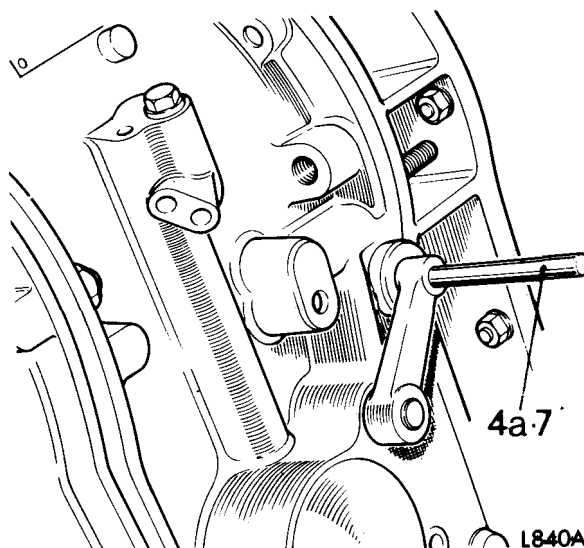
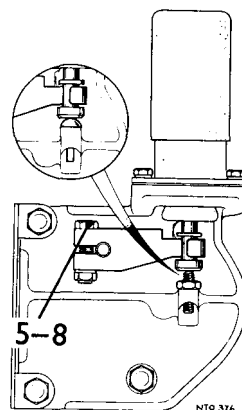

## OVERDRIVE 'A' TYPE

### SOLENOID

– Remove and refit 40.22.04

#### Removing

1. Raise vehicle.
2. Disconnect solenoid cable.
3. Remove two screws securing solenoid to bracket.
4. Withdraw solenoid and plunger (release plunger from operating lever fork).

#### Refitting

6. Reverse instructions 1 to 4.

### SOLENOID

– Remove, refit and adjust operating lever 40.22.05

Operation 40.22.04 plus operation 40.22.01, 5 to 10.

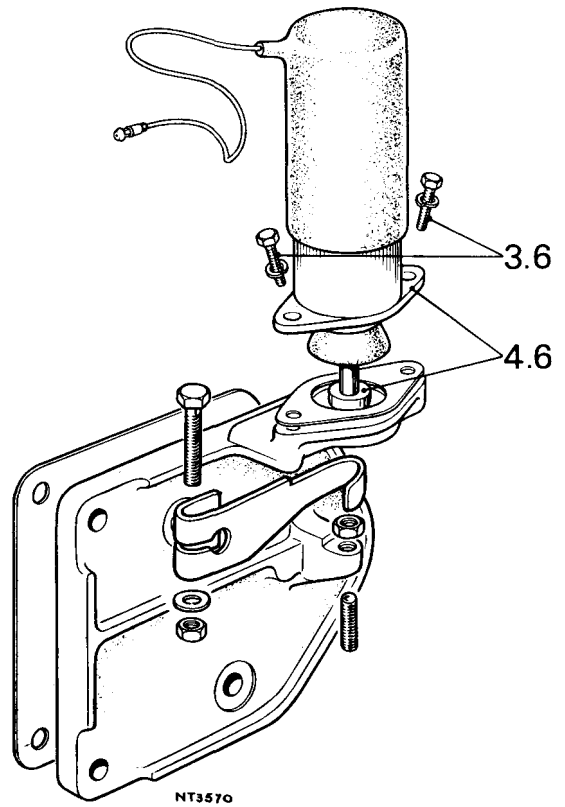

## LIST OF OPERATIONS

Control orifice	
— clean	40.16.19
Oil pump	
— overhaul	40.18.04
— remove and refit	40.18.01
Oil seal — rear	
— remove and refit	40.15.01
Operating pistons	
— overhaul	40.16.29
— remove and refit	40.16.24
Overdrive assembly	
— hydraulic pressure test	40.20.01
— overhaul or dismantle	40.20.10
— remove and refit	40.20.07
Pressure filter	
— remove and refit	40.10.08
Pump non-return valve	
— overhaul	40.16.14
— remove and refit	40.16.10
Relief valve and dashpot assembly	
— overhaul	40.16.07
— remove and refit	40.16.04
Solenoid and operating valve	
— overhaul	40.22.13
— remove and refit	40.22.04
— test	40.22.01
Speedo drive gear	
— remove and refit	40.25.01
Sump filter	
— remove and refit	40.10.01



# OVERDRIVE—J TYPE

NT2919

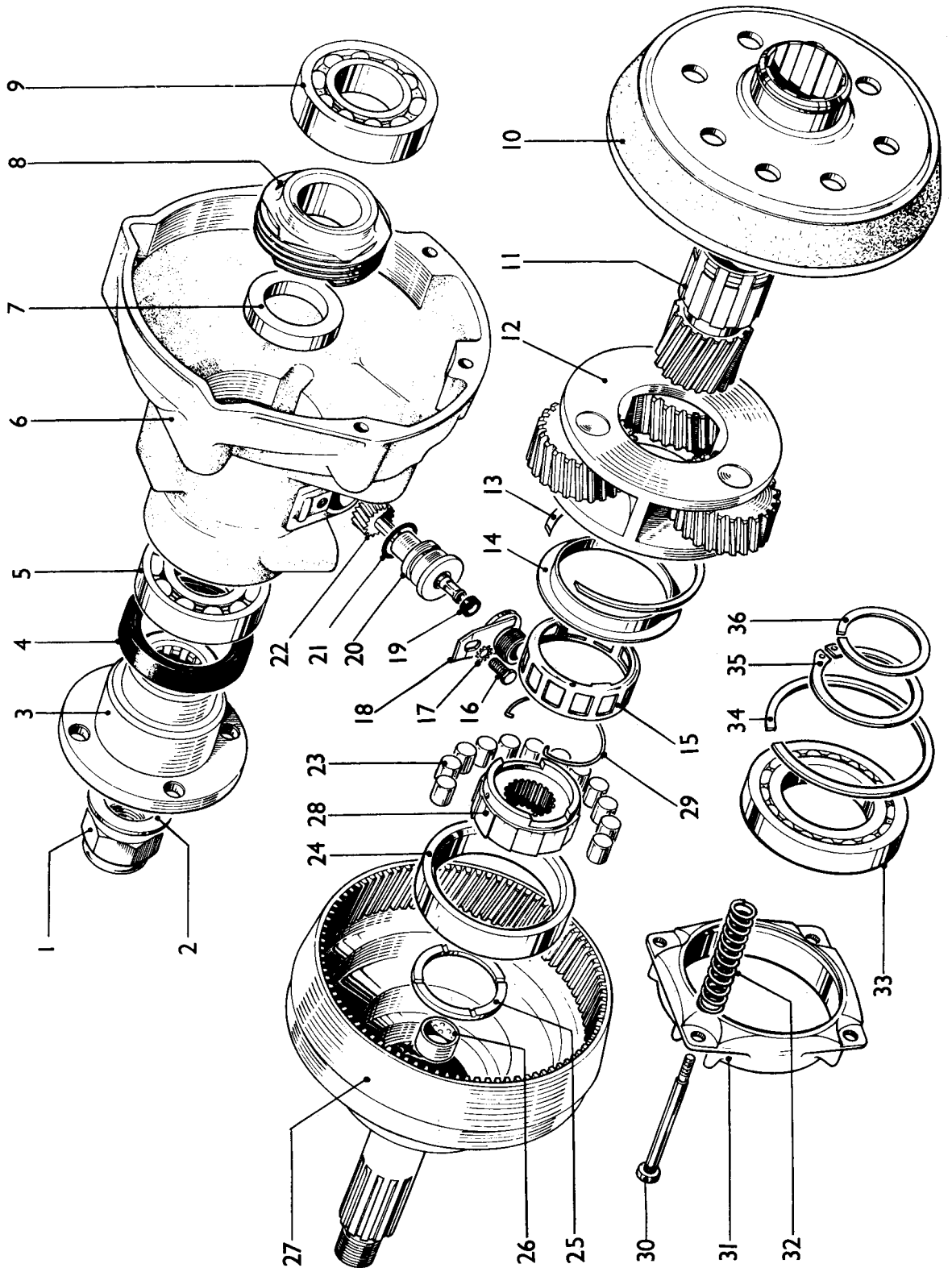



### J TYPE OVERDRIVE COMPONENTS

- |                             |  |                                  |
|-----------------------------|--|----------------------------------|
| 1. Locknut                  | 13. Circlip                            | 25. Thrust washer                |
| 2. Washer                   | 14. Oil thrower                        | 26. Mainshaft bush               |
| 3. Drive flange             | 15. Unidirectional clutch cage         | 27. Annulus                      |
| 4. Oil seal                 | 16. Bolt                               | 28. Unidirectional clutch hub    |
| 5. Annulus rear ball race   | 17. Star washer                        | 29. Unidirectional clutch spring |
| 6. Rear case                | 18. Speedometer retaining clamp        | 30. Thrust pin                   |
| 7. Spacer                   | 19. Oil seal                           | 31. Thrust ring                  |
| 8. Speedometer driving gear | 20. Speedo driven gear housing         | 32. Clutch return springs        |
| 9. Annulus front ball race  | 21. 'O' ring                           | 33. Thrust ball race             |
| 10. Clutch sliding member   | 22. Speedometer driven gear            | 34. Retaining circlip            |
| 11. Sun wheel               | 23. Unidirectional clutch rollers      | 35. Circlip for sliding member   |
| 12. Planet carrier assembly | 24. Unidirectional clutch roller track | 36. Circlip for sun wheel        |





### J TYPE OVERDRIVE COMPONENTS

- |                             |  |                                  |
|-----------------------------|--|----------------------------------|
| 1. Locknut                  | 13. Circlip                            | 25. Thrust washer                |
| 2. Washer                   | 14. Oil thrower                        | 26. Mainshaft bush               |
| 3. Drive flange             | 15. Unidirectional clutch cage         | 27. Annulus                      |
| 4. Oil seal                 | 16. Bolt                               | 28. Unidirectional clutch hub    |
| 5. Annulus rear ball race   | 17. Star washer                        | 29. Unidirectional clutch spring |
| 6. Rear case                | 18. Speedometer retaining clamp        | 30. Thrust pin                   |
| 7. Spacer                   | 19. Oil seal                           | 31. Thrust ring                  |
| 8. Speedometer driving gear | 20. Speedo driven gear housing         | 32. Clutch return springs        |
| 9. Annulus front ball race  | 21. 'O' ring                           | 33. Thrust ball race             |
| 10. Clutch sliding member   | 22. Speedometer driven gear            | 34. Retaining circlip            |
| 11. Sun wheel               | 23. Unidirectional clutch rollers      | 35. Circlip for sliding member   |
| 12. Planet carrier assembly | 24. Unidirectional clutch roller track | 36. Circlip for sun wheel        |

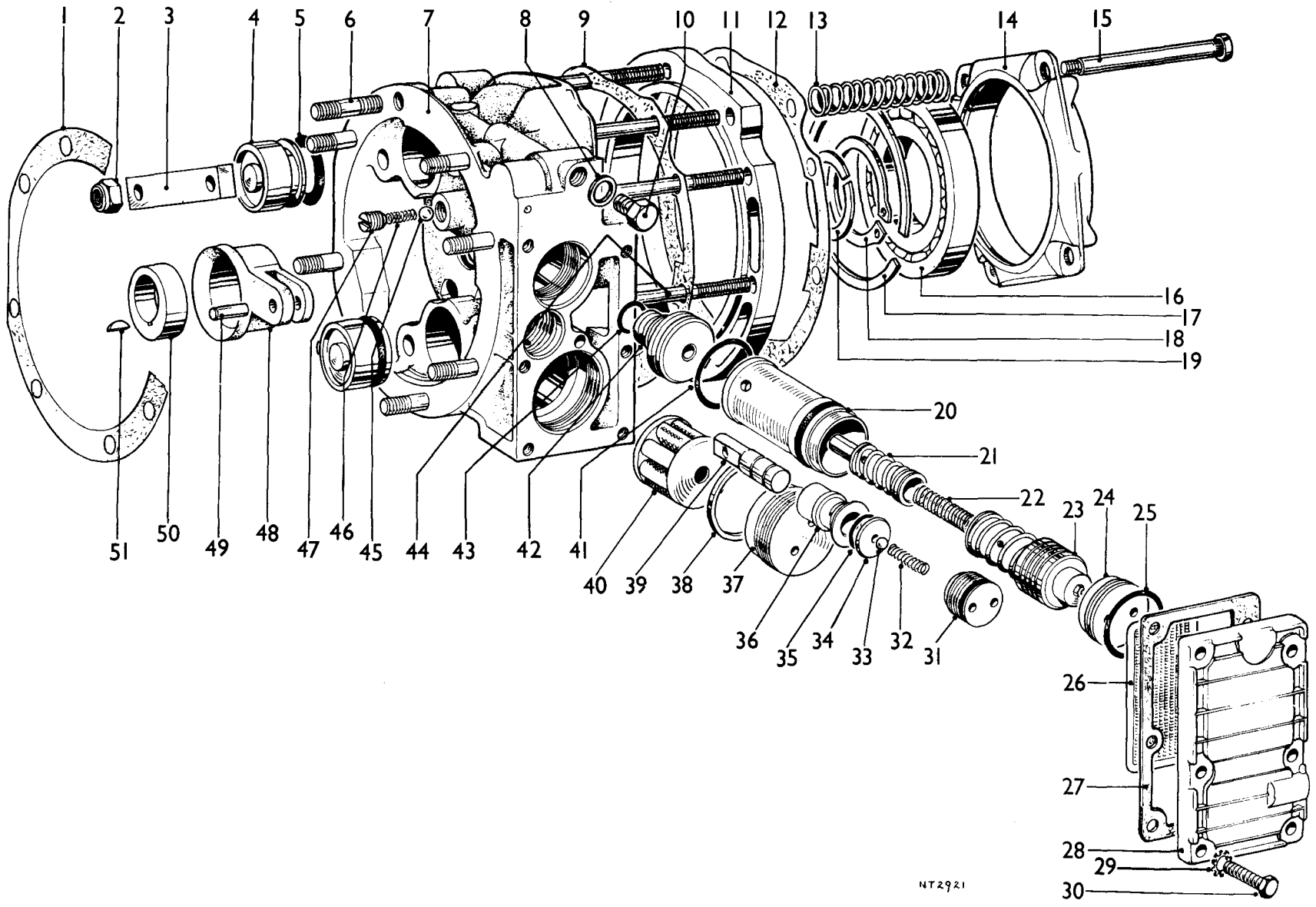

40.00.031

Triumph TR6 Manual, Part No. 545277 Issue 1



HT2921



### J TYPE OVERDRIVE COMPONENTS

- |                           |                                |                                     |
|---------------------------|--------------------------------|-------------------------------------|
| 1. Gasket                 | 18. Circlip for sliding member | 35. 'O' ring                        |
| 2. Locknut                | 19. Circlip for sun wheel      | 36. Pump body                       |
| 3. Bridge piece           | 20. Dashpot sleeve             | 37. Pressure filter plug            |
| 4. Operating piston       | 21. Relief valve assembly      | 38. Pressure filter washer          |
| 5. 'O' ring               | 22. Double dashpot spring      | 39. Pump plunger                    |
| 6. Stud                   | 23. Dashpot piston assembly    | 40. Pressure filter                 |
| 7. Main case              | 24. Dashpot plug               | 41. 'O' ring                        |
| 8. Washer (copper)        | 25. 'O' ring                   | 42. Relief valve body               |
| 9. Gasket                 | 26. Sump filter                | 43. 'O' ring                        |
| 10. Pressure tapping plug | 27. Sump gasket                | 44. Stud                            |
| 11. Brake ring            | 28. Sump                       | 45. Steel ball                      |
| 12. Gasket                | 29. Star washer                | 46. Lubrication relief valve spring |
| 13. Clutch return spring  | 30. Bolt                       | 47. Lubrication relief valve plug   |
| 14. Thrust ring           | 31. Pump plug                  | 48. Pump strap                      |
| 15. Thrust pin            | 32. Non-return valve spring    | 49. Pump in                         |
| 16. Thrust ball race      | 33. Steel ball                 | 50. Cam                             |
| 17. Retaining circlip     | 34. Non-return valve seat      | 51. Woodruff key                    |

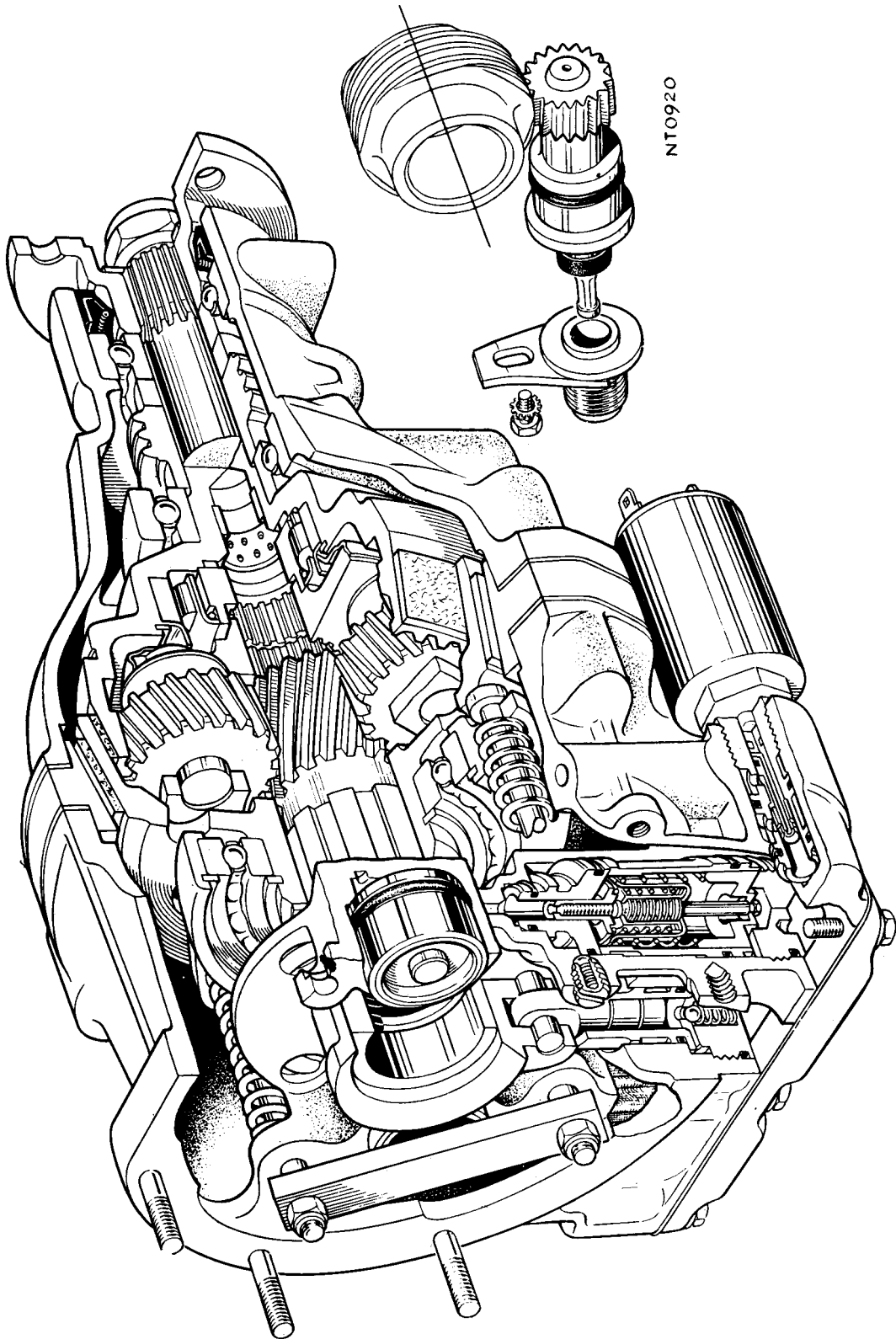

OVERDRIVE — J TYPE

## INTRODUCTION

The overdrive is an additional gear unit between the gearbox and propeller shaft. When in operation it provides a higher overall gear ratio than that given by the final drive, crown wheel and pinion.

The primary object of an overdrive is to provide open road cruising at an engine speed lower than it would be in normal top gear. This reduced engine speed gives a considerable reduction in petrol consumption and increase in engine life. Overdrive may also be used on the indirect gears to enhance performance or to provide easy and clutchless gear changing, for example in town traffic.

The overdrive is operated by an electric solenoid controlled by a switch, fitted in the gear lever knob. An inhibitor switch is fitted in the electrical circuit to prevent engagement of overdrive in reverse, and some or all of the indirect gears.

Overdrive can be engaged or disengaged at will at any speed, but usually above 30 m.p.h. in top gear. It should be operated without using the clutch pedal and at any throttle opening because the unit is designed to be engaged and disengaged when transmitting full power. The only precaution necessary is to avoid disengaging overdrive at too high a road speed, particularly when using it in an indirect gear, since this would cause excessive engine revolutions.

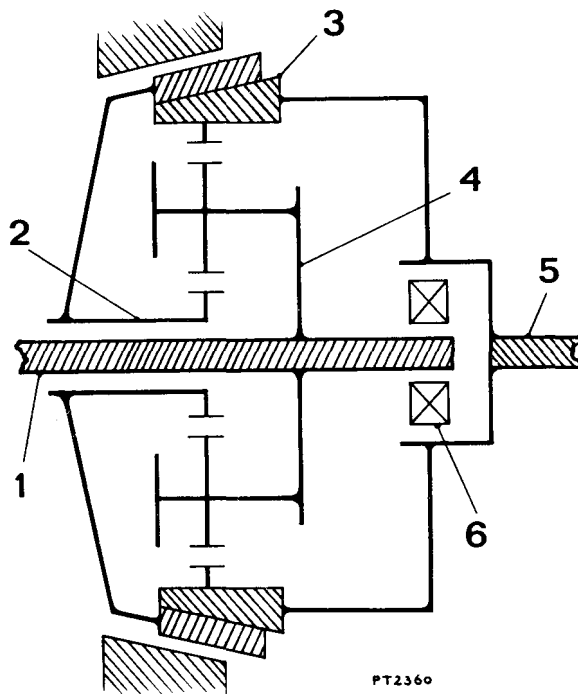

### KEY

1. Input shaft connected to planet carrier.
2. Sun gear.
3. Annulus.
4. Planet carrier.
5. Output shaft connected to annulus.
6. Roller clutch.

## WORKING PRINCIPLES

The overdrive gears are epicycle and consist of a central sunwheel meshing with three planet gears which in turn mesh with an internally toothed annulus. All gears are in constant mesh. The planet carrier is attached to the input shaft and the annulus is integral with the output shaft.

The unit is shown diagrammatically in PT 3355.

An extension of the gearbox mainshaft forms the overdrive input shaft. Forward direct drive (PT 3355) power is transmitted from this shaft to the inner member of uni-directional clutch and then to the outer member of this clutch through rollers which are driven up inclined faces and wedge between the inner and outer members. The outer member forms part of the combined annulus and output shaft.

The gear train is inoperative. A cone clutch is mounted on the externally splined extension of the sunwheel and is loaded in contact with the annulus by a number of springs which have their reaction against the casing of the overdrive unit. The spring load is transmitted to the clutch member through a thrust ring and ball bearing. This arrangement causes the inner friction lining of the cone clutch to contact the outer cone of the annulus and rotate with the annulus, whilst the springs and thrust ring remain stationary. Since the sunwheel is splined to the clutch member the whole gear train is locked, permitting over-run and reverse torque to be transmitted by the cone clutch, without which the uni-directional clutch would give a freewheel condition. Additional load is imparted to the clutch member, during over-run and reverse, by the sunwheel which, due to the helix angle of its gear teeth, thrusts rearward and has for its reaction member the cone clutch.

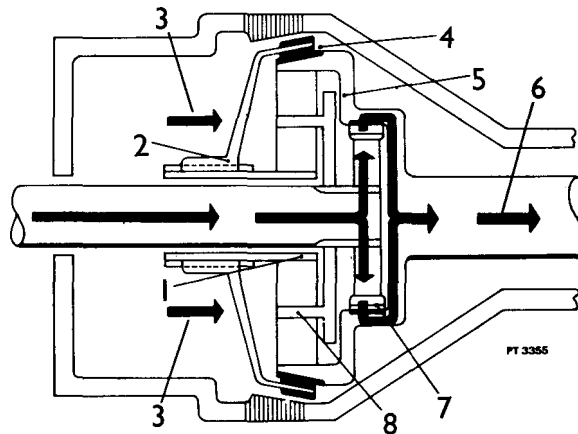

### IN DIRECT DRIVE

#### KEY

1. Sunwheel.
2. Sliding cone clutch.
3. Spring pressure.
4. Annulus and sunwheel locked.
5. Annulus.
6. To propshaft.
7. Uni-directional roller clutch.
8. Planet wheels.

PT3356 shows the position of the cone clutch when overdrive is engaged.

It will be seen that it is no longer in contact with the annulus but has moved forward so that its outer friction lining is in contact with a brake ring forming part of the overdrive casing. The sunwheel to which the clutch is attached is therefore held stationary. The output shaft and annulus continue to rotate at the same speed, so the planet wheels rotate on their axes around the stationary sunwheel, reducing the planet carrier and input shaft speed. The uni-directional clutch permits the outer member to over run the inner member.

This condition gives a lower engine speed for a given road speed.

Movement of the cone clutch in a forward direction is effected by means of hydraulic pressure which acts upon two pistons when a valve is opened, by operating the driver controlled selector switch. This hydraulic pressure overcomes the springs which load the clutch member on to the annulus and causes the clutch to engage the brake ring with sufficient load to hold the sun wheel at rest. Additional load is imparted to the clutch in a forward direction due to the helix angle of the gear teeth.

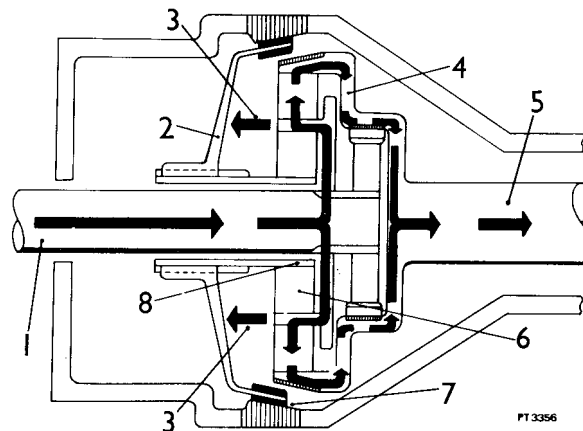

#### IN OVERDRIVE

#### KEY

1. From gearbox.
2. Sliding cone clutch.
3. Hydraulic pressure.
4. Annulus driven by planet gears.
5. To propshaft.
6. Planet wheels.
7. Locked cone clutch holds sunwheel.
8. Sunwheel.

## SOLENOID AND OPERATING VALVE

### Energising

The solenoid and operating valve are a self contained factory sealed unit, situated on the main case of the overdrive.

The solenoid has a single coil, encapsulated and completely waterproof, with a continuous current consumption of approximately 2 amperes. There are no electrical contacts in the solenoid.

In direct drive a residual pressure of approximately 20 p.s.i. maintains the system in primed condition and provides lubrication. This is achieved by the relief valve

piston reacting on the residual pressure spring. When overdrive is engaged pressure increases to a pre-determined operating pressure of 430/460 p.s.i. When the solenoid is energised, its valve opens and oil which is at residual pressure is directed via passage 'Z' to the bottom of the dashpot piston. This causes the dashpot piston to rise and compress the dashpot spring causing a progressive increase in hydraulic pressure until the piston reaches its stop by which time the relief valve spring has been compressed to its working length, thus giving full operating pressure. This pressure causes the operating pistons to move forward overcoming the clutch springs and engages the cone clutch in the brake ring.

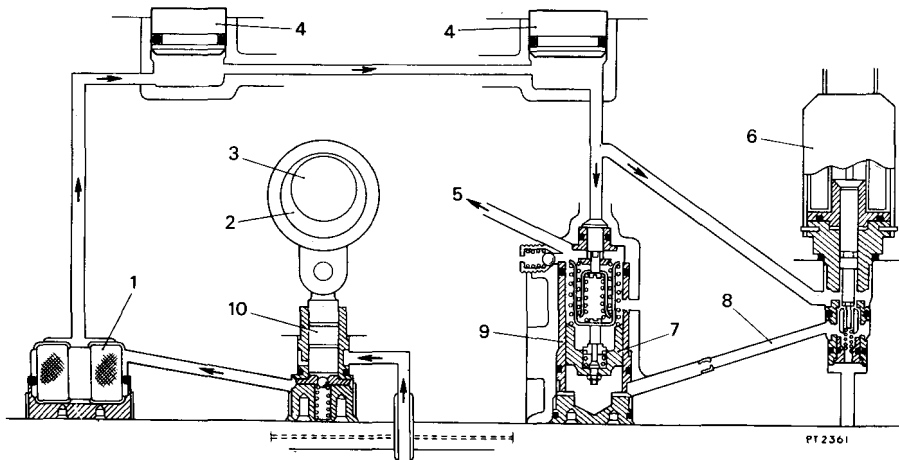

### KEY

- |                            |                    |
|----------------------------|--------------------|
| 1. Pressure filter.        | 6. Solenoid valve. |
| 2. Cam.                    | 7. Dashpot.        |
| 3. Input shaft.            | 8. Passage Z.      |
| 4. Operating pistons.      | 9. Relief valve.   |
| 5. To central lubrication. | 10. Pump.          |



## De-energising

When the solenoid is de-energised its valve is closed by a spring, cutting off the oil supply from the pump to the dashpot. Oil is now exhausted via the control orifice in passage 'Z' which allows the relief valve spring to relax to

its direct drive position. The dashpot spring moves the dashpot piston to its stop allowing the system pressure to progressively drop which enables the clutch springs to move the cone clutch gently into contact with the annulus.

The residual pressure of approximately 20 p.s.i. is now maintained in direct drive.

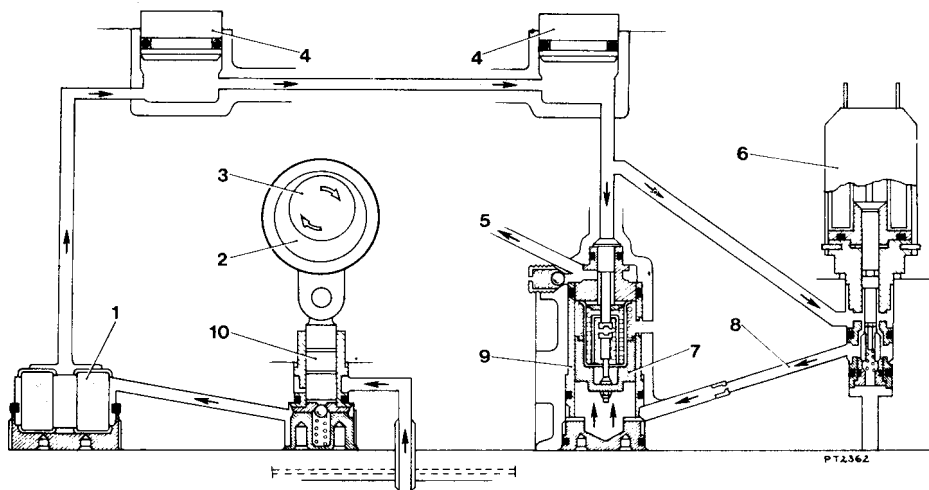

## KEY

- |                            |                    |
|----------------------------|--------------------|
| 1. Pressure filter.        | 6. Solenoid valve. |
| 2. Cam.                    | 7. Dashpot.        |
| 3. Input shaft.            | 8. Passage Z.      |
| 4. Operating pistons.      | 9. Relief valve.   |
| 5. To central lubrication. | 10. Pump.          |

## HYDRAULIC SYSTEM

Hydraulic pressure is developed by a plunger type pump, cam operated from the input shaft. The pump draws oil from an air-cooled sump through a suction filter and delivers it via non-return valve, through a pressure filter to the operating pistons, solenoid valve and relief valve. Incorporated in the relief valve is a spring dashpot which ensures smooth overdrive engagement and disengagement under varying conditions.

## LUBRICATION SYSTEM

Oil is discharged through the relief valve direct to an annular channel in the centre of the main casing and then through drillings in the mainshaft to the annulus spigot bearing. Immediately in front of the spigot bearing a radial drilling passes oil through the uni-directional clutch, from here it is directed by an oil thrower into a catcher disc on the planet carrier and to the planet bearings via the hollow planet bearing pins.

The pressure in the lubrication passage is controlled by the lubrication relief valve.

## MAINTENANCE

The level of oil should be checked at the gearbox. To drain the sump of the overdrive must be removed as well as the gearbox drain plug. This will provide access to the suction and pressure filters, which should also be removed and cleaned before replenishing with new oil.

Following complete draining and refilling, run the transmission for a short period then re-check the oil level.

It is essential that only the approved lubricant is used for topping up and refilling. **ON NO ACCOUNT SHOULD ANY ANTI-FRICTION ADDITIVES BE USED.**

## CLEANLINESS

Scrupulous cleanliness must be maintained throughout all servicing operations. Even minute particles of dust, dirt or lint from cleaning cloths may cause malfunction. When the overdrive and gearbox have a common oil supply, it is naturally as important that the same high standards of cleanliness must be maintained when servicing the gearbox.

Great care must be taken to avoid the entry of dirt when topping up or re-filling.

For cleaning use petrol or paraffin ONLY, and on no account should water be used.

FAULT DIAGNOSIS AND RECTIFICATION

Fault	Possible Cause	Remedy
OVERDRIVE DOES NOT ENGAGE	a. Insufficient oil in unit.	Top up gearbox/overdrive.
	b. Solenoid not energising.	Check electrical circuit.
	c. Solenoid energising but not operating.	Remove solenoid and check operation of solenoid valve.
	d. Insufficient hydraulic pressure	Fit pressure gauge and check operating pressure.
		Clean filters.
		Reseat pump non-return valve if necessary.
	Check relief valve operation.	Clean control orifice <b>DO NOT PROBE WITH WIRE.</b>
	e. Pump damaged.	Remove and check.
	f. Internal damage.	Remove and examine overdrive.
THIS CALLS FOR IMMEDIATE ATTENTION. DO NOT REVERSE THE CAR, OR EXTENSIVE DAMAGE MAY BE CAUSED.		
*OVERDRIVE DOES NOT RELEASE	a. Fault in electrical control circuit.	Check electrical system for closed circuit.
	b. Sticking solenoid valve.	Remove solenoid and check valve.
	c. Residual pressure too high.	Fit pressure gauge and check residual pressure. If pressure is too high check for sticking relief valve.
	d. Control orifice blocked.	Check and blow through with compressed air. <b>DO NOT PROBE WITH WIRE.</b>
	e. Cone clutch sticking.	Tap the brake ring several times with a hide mallet.
	f. Internal damage.	Remove and examine overdrive.
CLUTCH SLIP IN OVERDRIVE	a. Insufficient oil in unit.	Top up gearbox/overdrive.
	b. Operating pressure too low.	Fit the pressure gauge and check the pressure. Check the filters, pump non-return ball valve and relief valve.
	c. Sticking solenoid valve.	Check the control orifice is clear. Remove solenoid and check operation of solenoid valve.
	d. Worn or glazed clutch linings.	Remove overdrive and examine the linings or mechanical obstruction to movement of cone clutch.
(THESE SYMPTOMS MAY OCCUR TOGETHER OR SEPARATELY)		
SLOW DIS- ENGAGEMENT OF OVERDRIVE FREE- WHEELING ON OVER-RUN SLIP IN REVERSE GEAR	a. Sticking relief valve.	Check for sticking relief valve.
	b. Sticking or partially blocked control valve	Remove solenoid and check.
	c. Control orifice blocked.	Check to ensure the orifice is clear.
	d. Internal damage.	Remove and examine overdrive.



## DIMENSIONS AND CLEARANCES FOR PARTS WHEN NEW

	Dimensions New	Clearances New
<b>CAM</b>		
Outside Diameter of Cam	1.4590 in/ 1.4600 in	.0010 in/ .0030 in
Inside Diameter of Pump Strap	1.4610 in/ 1.4620 in	
<b>GEARBOX MAINSHAFT</b>		
Diameter of Oil Transfer	.9640 in/ .9650 in	.0010 in/ .0030 in
Inside Diameter of Maincase at Oil Transfer	.9660 in/ .9670 in	
Diameter at Sunwheel	.9410 in/ .9430 in	.0040 in/ .0080 in
Inside Diameter of Sunwheel Bush (Where Fitted)	.9470 in/ .9490 in	
Diameter at Mainshaft Spigot	.5620 in/ .5625 in	.0003 in/ .0018 in
Inside Diameter at Spigot Bearing	.5628 in/ .5638 in	
<b>OPERATING PISTONS</b>		
Operating Piston Diameter	1.2492 in/ 1.2497 in	.0003 in/ .0020 in
Operating Piston Bore Diameter	1.2500 in/ 1.2512 in	
<b>RELIEF VALVE PUMP</b>		
Pump Plunger Diameter	.4996 in/ .5000 in	.0003 in/ .0013 in
Pump Body Bore	.5003 in/ .5009 in	
<b>RELIEF VALVE</b>		
Outside Diameter of Relief Valve Piston	.2496 in/ .2498 in	.0002 in/ .0009 in
Inside Diameter of Relief Valve Body	.2500 in/ .2505 in	
Outside Diameter of Dashpot Piston	.9370 in/ .9373 in	.0002 in/ .0015 in
Inside Diameter of Dashpot Sleeve	.9375 in/ .9385 in	
<b>SPEEDO PINION</b>		
Outside Diameter of Speedo Pinion	.3105 in/ .3110 in	.0010 in/ .0030 in
Inside Diameter of Speedo Bearing	.3120 in/ .3135 in	
<b>MISCELLANEOUS</b>		
Sliding Member Travel from Direct Drive to Overdrive (Measured at Bridge Pieces).	.090 in/ .115 in	

**SUMP FILTER**

— Remove and refit

40.10.01

**Removing**

1. Remove the six bolts and star washers holding the sump on.
2. Remove the sump.
3. Remove the sump gasket.
4. Pull the filter out.
5. Clean the filter in either paraffin or petrol.

**Refitting**

6. Push the filter back into position.
7. Refit the sump and gasket.
8. Refit the bolts and star washers and tighten to a torque of 6 lbf ft (0.8 kgf m).

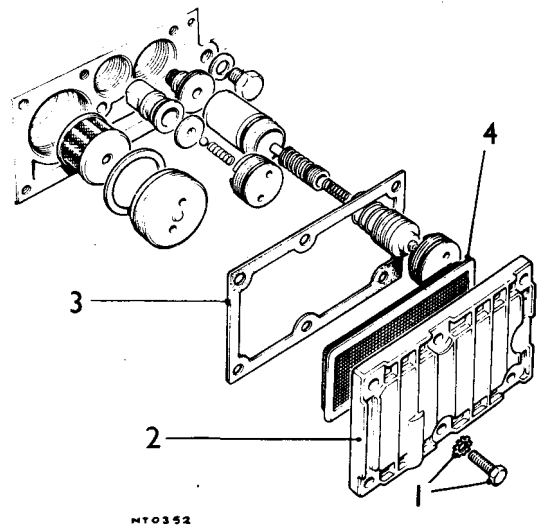

**PRESSURE FILTER**

— Remove and refit

40.10.08

**Removing**

1. Remove the sump and suction filter.
2. Remove the pressure filter base plug (largest plug), using tool L354; the filter element will come away with the plug.
3. Remove the aluminium washer which locates on the shoulder in the filter bore.
4. Remove foreign matter and wash the element in petrol or paraffin.
5. Renew the aluminium washer if there are any signs of damage or scoring.
6. Refit the filter and pressure filter base plug, using tool L354.
7. Tighten up until the plug is flush with the base, a torque loading of 16 lbf ft (2.2 kgf m).

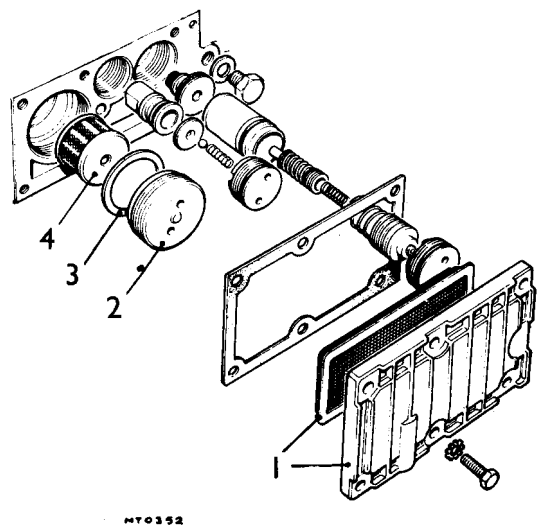

## OVERDRIVE — J TYPE

### OIL SEAL — REAR

— Remove and refit

40.15.01

#### Removing

1. Remove the nut.
2. Remove the washer.
3. Remove the drive flange.
4. Remove the rear oil seal, using special tool L176A with 7657.

#### Refitting

5. Fit the oil seal using special tool L177 with 550.
6. Refit the drive flange.
7. Refit the washer.
8. Fit a new self-locking nut and tighten to a torque of 80 to 130 lbf ft (11.1 to 18.0 kgf m).

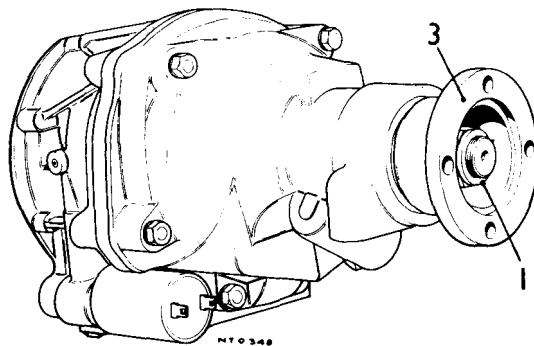

### RELIEF VALVE AND DASHPOT ASSEMBLY

— Remove and refit

40.16.04

**NOTE:** If the vehicle has been in recent use, care should be taken to avoid hot oil burning the skin.

1. Remove six bolts and star washers securing the sump to the main case.
2. Remove the gasket.
3. Remove the gauze filter.
4. Using Churchill tool L354, remove the relief valve plug.
5. Withdraw the dashpot piston complete with its component springs and cup.
6. Remove the residual pressure spring.

**NOTE:** This is the only loose spring in the general assembly.

*continued*

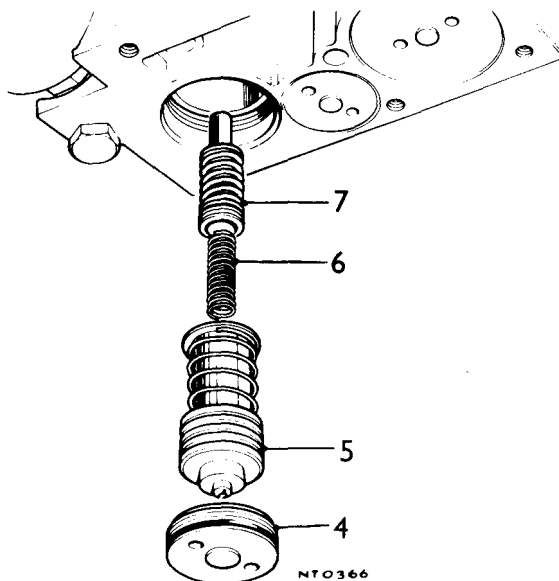

7. The relief valve piston assembly can now be withdrawn by carefully pulling down with a pair of pliers.
8. Insert tool L401 into the now exposed relief valve bore (taking care not to damage this) and withdraw the relief valve together with the dashpot sleeve.  
**NOTE:** Do not dismantle the dashpot and relief valve piston assemblies otherwise the predetermined spring pressures will be disturbed.

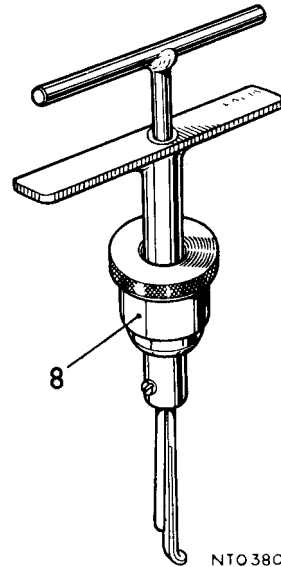

**Refitting**

9. Ensure that before assembly all the components are clean and lightly oiled.
10. Insert the relief body in the bore and, using the relief valve outer sleeve, push fully home.  
**NOTE:** The end with the 'O' ring is nearest to the outside of the casing.
11. Position the relief valve spring and piston assembly into the dashpot cup, ensuring that both ends of the residual pressure spring are correctly located.
12. Carefully position these components in the relief valve outer sleeve, at the same time engaging the relief valve piston in its housing.
13. Fit the base plug and tighten it flush with the casing to a torque loading of 16 lbf ft (2.2 kgf m).

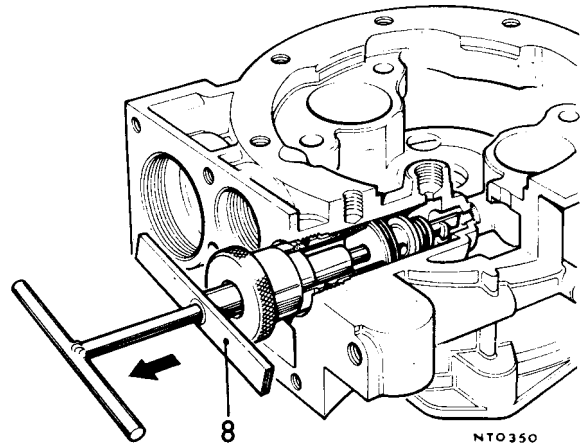

**RELIEF VALVE AND DASHPOT ASSEMBLY**

— Overhaul 40.16.07

1. Remove the relief valve and dashpot assembly. 40.16.04.
2. Inspect the pistons and ensure that they move freely in their respective housings.
3. Inspect the 'O' rings and ensure that they are in good condition.
4. If they are damaged at all, the 'O' ring should be renewed.
5. Refit the relief valve and dashpot assembly. 40.16.04.



## PUMP NON-RETURN VALVE

— Remove and refit

40.16.10

### Removing

1. Remove the overdrive sump.
2. Remove the suction filler.
3. With Churchill tool L354, remove the pump plug (centre plug) taking care not to lose the non-return valve spring and ball.
4. Remove the non-return valve seat.

### Refitting

5. Place the spring in the non-return valve plug.
6. Position the ball on the spring.
7. Locate the non-return seat on the ball.
8. Screw the complete assembly into the maincase, using tool L354.
9. Screw up flush with the case to a torque loading of 16 lbf ft (2.2 kgf m).

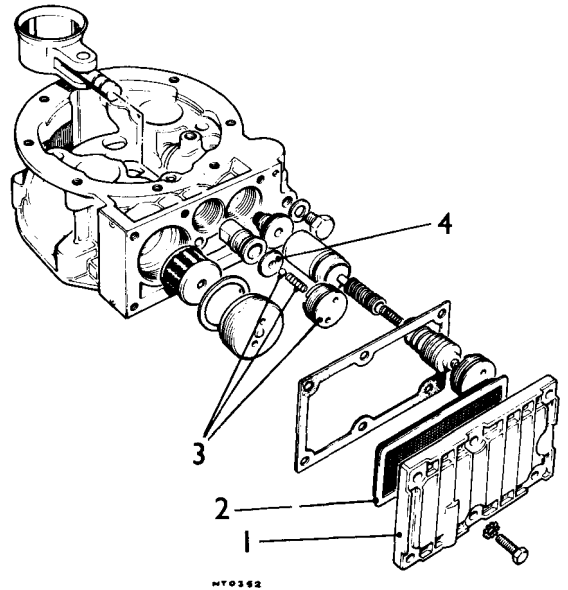

## PUMP NON-RETURN VALVE

— Overhaul

40.16.14

1. Remove the pump non-return valve. 40.16.10.
2. Carefully inspect the non-return valve ball and valve seat. If necessary, reseat the ball on the seat by tapping gently with a copper drift.
3. Ensure that the 'O' ring is undamaged.
4. If the 'O' ring is damaged, renew it.
5. Refit the 'O' ring after smearing with petroleum jelly.
6. Refit the pump non-return valve. 40.16.10.

**CONTROL ORIFICE**

– Clean 40.16.19

The control orifice is situated in the angled drilling between the relief valve and the solenoid control valve.

1. To gain access, remove the solenoid control valve. 40.22.04.
2. Remove the relief valve and outer sleeve. 40.16.04.
3. Clean the orifice with a high pressure air-line.  
**NOTE:** Do not attempt to clean the orifice with wire or its calibration may be impaired.
4. Refit the relief valve and outer sleeve. 40.16.04.
5. Refit the solenoid control valve. 40.22.04.

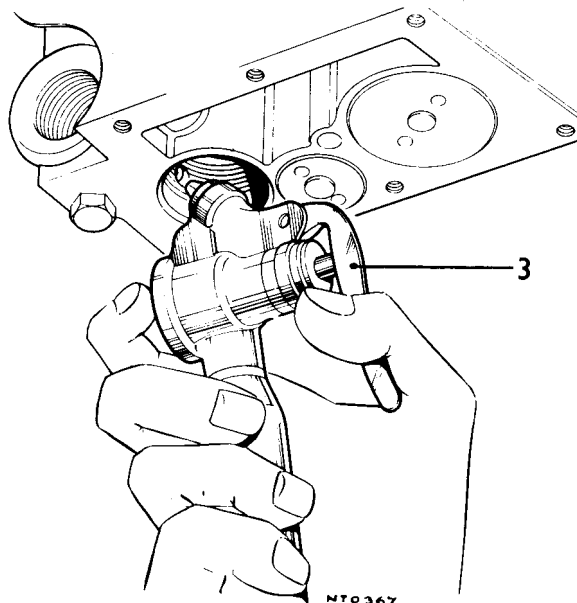

**OPERATING PISTONS**

– Remove and refit 40.16.24

**Removing**

1. Remove the gearbox and overdrive from the car. 37.20.01.
2. Remove the overdrive from the gearbox. 40.20.07.
3. Remove four nuts.
4. Remove two bridge pieces.
5. With a pair of pliers, remove the operating pistons, identifying them with their respective cylinders.

**Refitting**

6. Lightly oil the operating pistons.
7. Push the pistons into the housings.
8. Fit the two bridge pieces.
9. Fit and tighten the four new nuts to a torque of 6 to 8 lbf ft (0.8 to 1.1 kgf m).
10. Refit the overdrive to the gearbox. 40.20.07.
11. Refit the gearbox and overdrive to the car. 37.20.01.

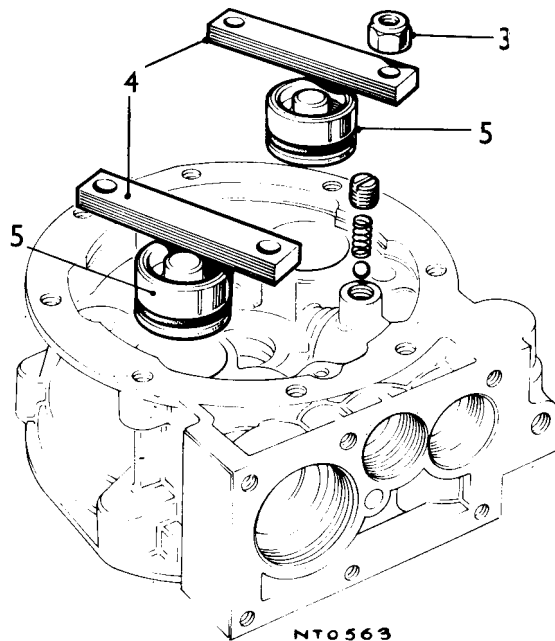

**OPERATING PISTONS**

– Overhaul 40.16.29

1. Remove the operating pistons. 40.16.24.
2. Inspect each of the 'O' rings for any damage or wear.
3. If any damage is found the ring must be replaced and smeared with petroleum jelly.
4. Refit the operating pistons. 40.16.24.





## OVERDRIVE—J TYPE

### OIL PUMP

— Remove and refit

40.18.01

#### Removing

1. Remove the overdrive from the car. 40.20.07.
2. Remove the sump and filter. 40.10.01.
3. Remove the pump plug, using tool L354A.
4. Remove the non-return valve spring.
5. Remove the steel ball.
6. Remove the non-return valve seat.
7. Work the pump body out of the main casing.
8. Remove the pump plunger assembly.

#### Refitting

9. Position the pump plunger assembly in the main case.
10. Fit the pump body in the main casing, ensuring that the flat on the body faces towards the pressure filter housing.
11. Fit the non-return valve seat.
12. Fit the steel ball.
13. Fit the non-return valve spring into the pump plug.
14. Fit the plug and tighten to a torque of 16 lbf ft (2.2 kgf m).
15. Clean the sump filter and replace.
16. Fit the sump with a new joint.
17. Tighten the sump bolts to a torque of 6 lbf ft (0.8 kgf m).
18. Refit the overdrive to the car. 40.20.07.

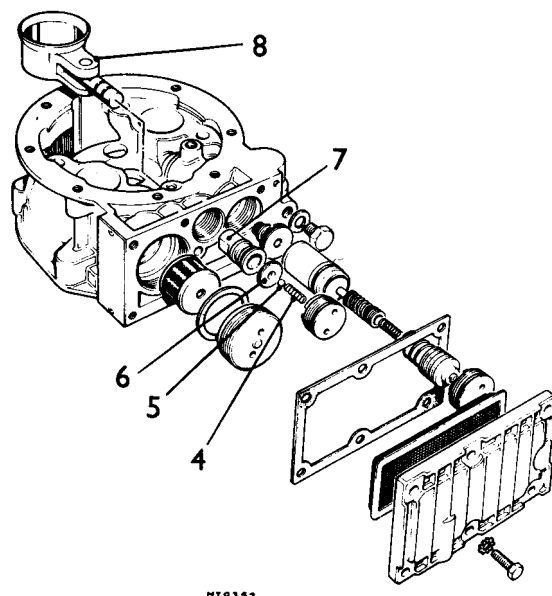
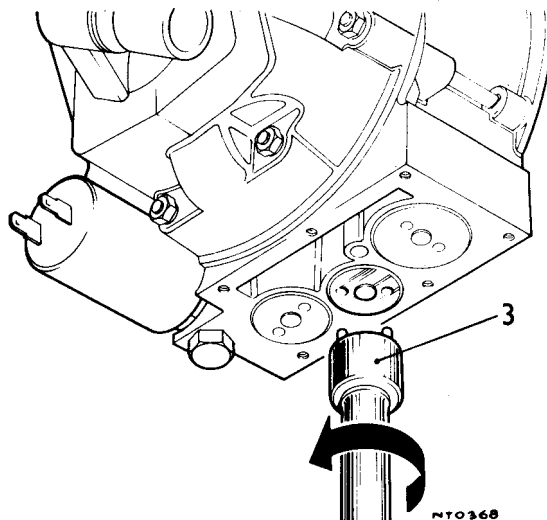

### OIL PUMP

— Overhaul

40.18.04

1. Remove the pump plunger assembly. 40.18.01.
2. Check that the strap is a good fit on the mainshaft cam.
3. Check that there is no excess play between the strap and the plunger.
4. If the pump plunger assembly is worn or damaged, this must be replaced as a complete assembly.
5. Check that the 'O' rings on the pump body and the plug are perfect; if not, these must be replaced.
6. Refit the pump plunger assembly. 40.18.01.

40.18.01J

40.18.04J

## OVERDRIVE ASSEMBLY

## — Hydraulic pressure test

40.20.01

1. Check that the oil level in the gearbox is correct.
2. Remove the plug adjacent to the solenoid and fit a hydraulic pressure gauge (special tool L188) together with adaptor (L188-2).
3. Jack the car up and run the transmission at approximately 25 m.p.h. (40 km/h).
4. In direct drive the residual pressure should register on the gauge to approximately 20 lbf/in<sup>2</sup> (1.4 kgf/cm<sup>2</sup>).
5. Engage the overdrive; a pressure of 430 to 460 lbf/in<sup>2</sup> (30.10 to 32.20 kgf/cm<sup>2</sup>) should be recorded.
6. Disengage the overdrive and the gauge should return to show the residual pressure.

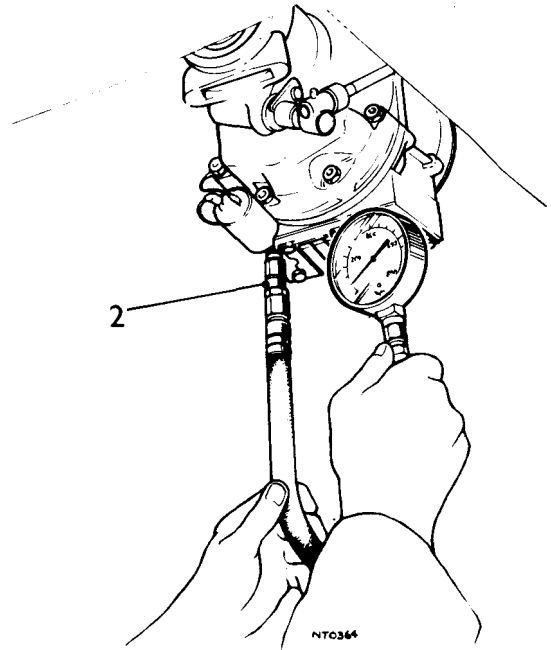

## OVERDRIVE ASSEMBLY

— Remove and refit

40.20.07

### Removing

**NOTE:** Before commencing overdrive removal it is advisable to raise the rear wheels and run the transmission. Engage overdrive, then disengage with the clutch depressed leaving the overdrive ready for removal. This will release the spline loading between the planet carrier and the uni-directional roller clutch which could make removal difficult.

1. Remove the gearbox and overdrive from the car as operation number 37.20.01.
2. Remove the eight  $\frac{1}{2}$  in U.N.F. nuts securing the unit to the adaptor plate.
3. Remove the overdrive over the mainshaft, leaving the adaptor plate in position on the gearbox.  
If difficulty is experienced in separating the overdrive from the gearbox, use the following procedure: Remove the hexagon plug adjacent to the solenoid, and screw in and tighten tool L402. Energize the solenoid, then pressurize the unit by pumping clean oil through the nipple on the tool with a lubrication gun. This will release the spline loading on the mainshaft and permit easy removal. De-energize the solenoid when the overdrive has separated by about  $\frac{3}{4}$  in (19 mm).
4. Use a screwdriver of suitable length to rotate the inner member of the uni-directional roller clutch (this is the innermost set of splines), in an anti-clockwise direction until the splines of this member are in line with the splines in the planet carrier.
5. Ensure that the pump cam and sun gear spring ring are correctly located on the mainshaft.
6. Rotate the gearbox mainshaft so that the peak of the pump cam is at the bottom to assist engagement with the pump strap.
7. Engage the bottom gear in the gearbox.
8. Fit a new joint to the front face of the overdrive.
9. Offer up the overdrive to the gearbox.
10. Rotate the output shaft of the unit in a clockwise direction.
11. At the same time apply slight pressure until the splines are engaged.
12. Ensure that the pump strap assembly rides smoothly onto the cam and that the overdrive pushes home to the adaptor plate face without excessive force.
13. Fit and tighten the eight nuts which secure the unit.
14. If the overdrive fails to meet the adaptor plate face by approximately  $\frac{5}{8}$  in (16 mm) it means that the planet carrier and the uni-directional roller splines have become mis-aligned. In this case remove the unit and re-align the splines.

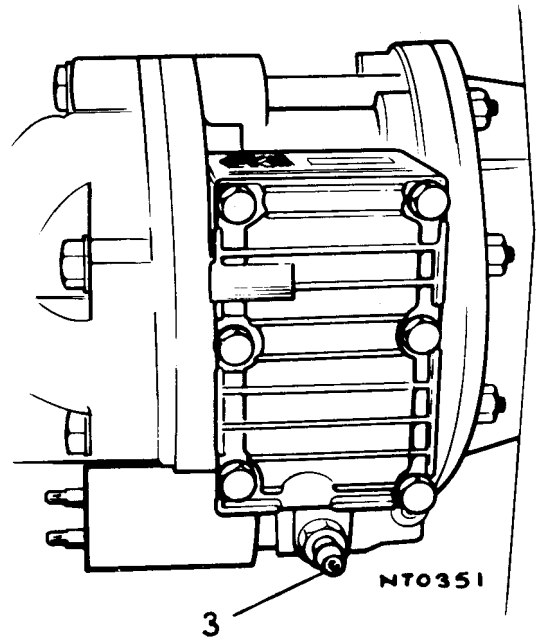

OVERDRIVE ASSEMBLY

— Overhaul or dismantle 40.20.10

1. Remove the gearbox and overdrive from the car. 37.20.01.
  2. Remove the overdrive from the gearbox. 40.20.07.
  3. Before starting to dismantle the overdrive assembly, the exterior of the casings must be thoroughly cleaned.
  4. Mount the unit vertically in a vice with the use of 'soft' jaws.
  5. Remove four nuts securing the bridge pieces.
  6. Remove the bridge pieces.
  7. Progressively release the six nuts around the main casing to release the clutch return spring pressure.
  8. Note the position of the two copper washers which fit on the two studs at the top of the casing.
  9. Remove all the washers from the casing.
  10. Separate the main casing complete with the brake ring from the rear case.
  11. Lift out the sliding member assembly complete with the sun wheel.
  12. Lift out the planet carrier assembly, taking care not to damage the oil catcher which is attached to the underside of the carrier.
  13. Tap the brake ring from its spigot in the main casing with a suitable drift.
  14. Using a pair of pliers, withdraw the operating pistons.
  15. Remove the sump and suction filter. 40.10.01.
  16. Remove the relief valve assembly. 40.16.04.
  17. Remove the pump non-return valve assembly. 40.16.10.
  18. Remove the oil pump assembly. 40.18.01.
  19. Remove the pressure filter. 40.10.08.
  20. Remove the solenoid control valve. 40.22.09.
  21. Inspect the main casing for cracks.
  22. Examine the operating cylinder bores for scores or wear.
  23. Check the operating pistons for wear.
  24. Replace the sealing rings if there is any sign of damage.
  25. Remove the circlip from the sun wheel extension.
  26. Take out the sun wheel.
  27. Remove the circlip from its groove on the cone clutch hub.
  28. Tap out the clutch from the thrust ring bearing, using a hide mallet.
  29. Extract the large circlip.
  30. Press the bearing from its housing.
  31. Examine the clutch linings on the sliding member for any signs of excessive wear or charring.
  32. If there is any sign of this condition, the sliding member complete must be replaced.
- NOTE:** It is not possible to fit new linings as these are precision machined after they are bonded.

*continued*

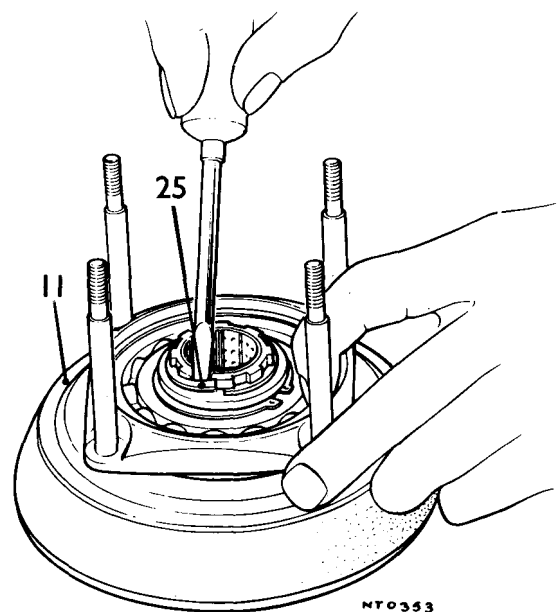
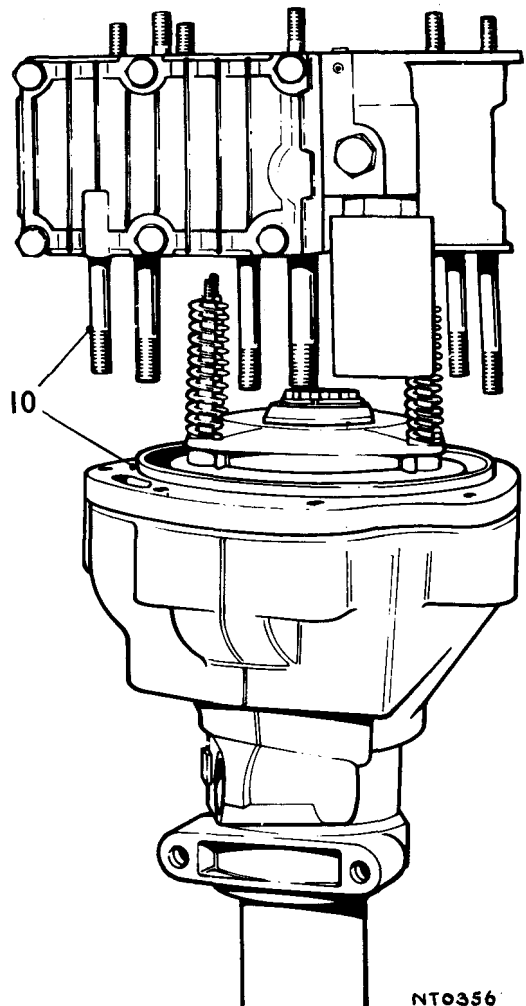

# OVERDRIVE—J TYPE

33. Check the ball race and ensure that it rotates smoothly as this can be a source of noise when running in direct drive.
34. Examine the clutch return springs for any signs of distortion or collapse.
35. Inspect the sun wheel teeth for wear or damage.
36. Inspect the planet gears for damage or wear.
37. Check the planet gear bearings for any excessive clearance.
38. Examine the oil thrower for damage.
39. Using a screwdriver blade, remove the circlip.
40. Lift out the oil thrower.
41. Place tool L178 over the exposed uni-directional roller clutch.
42. Lift the inner member complete with rollers into the special tool.
43. Remove the bronze thrust washer.
44. Remove the speedometer drive bolt.
45. Remove the speedometer driven gear clamp.
46. Pull the speedometer driven gear out with a pair of pliers; this will also remove the speedometer bush.

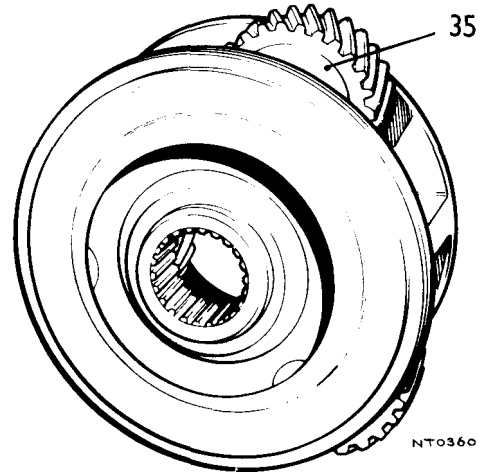

*continued*

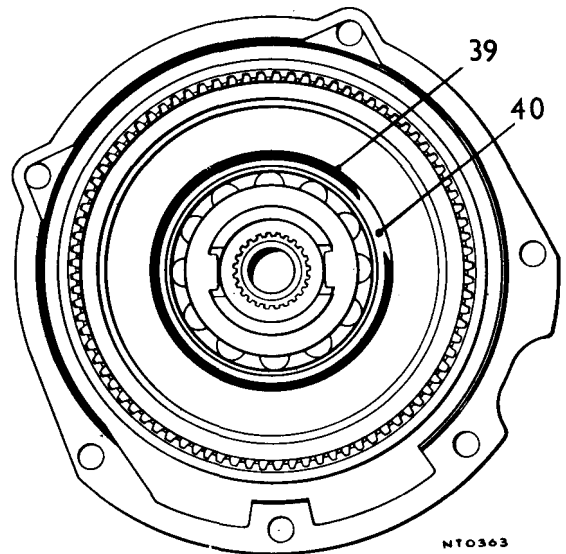
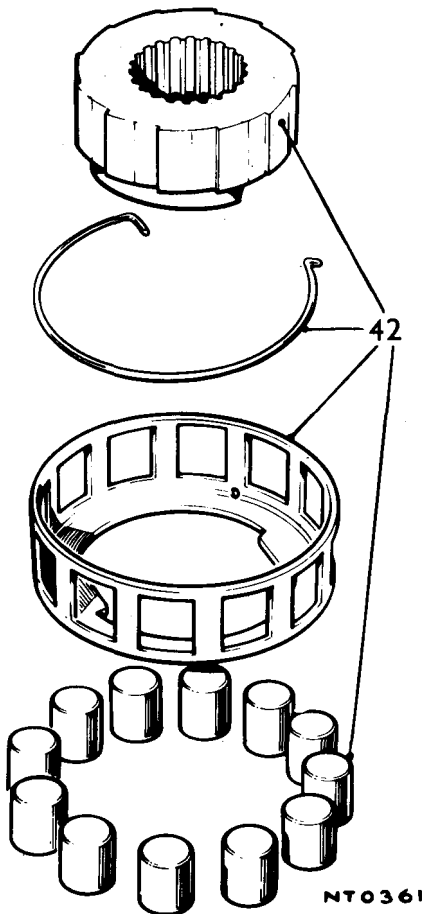

47. Separate the bush from the driven gear.
  48. Remove the coupling flange nut and washer.
  49. Withdraw the flange, using a suitable extractor.
  50. Drift out the annulus, using a hide mallet applied to the end of the tail shaft.
  51. The front bearing, speedometer drive gear and spacer will be withdrawn together with the annulus.
  52. Remove the oil seal.
  53. Drive out the rear bearing.
  54. Check, and renew if necessary, all the 'O' rings.
  55. Inspect the teeth and the cone surface of the annulus for wear.
  56. Check that the uni-directional clutch rollers are not chipped.
  57. Check that the inner and outer members are not damaged.
  58. Examine the spring and cage for distortion.
  59. The oil seal must be replaced.
  60. Examine the speedometer drive and driven gears for wear and chafing; in either case they must be replaced.
  61. Position the speedometer drive gear in the rear casing with its plain boss facing the front bearing.
- NOTE:** The speedometer drive gear cannot be fitted from the rear of the casing.

*continued*

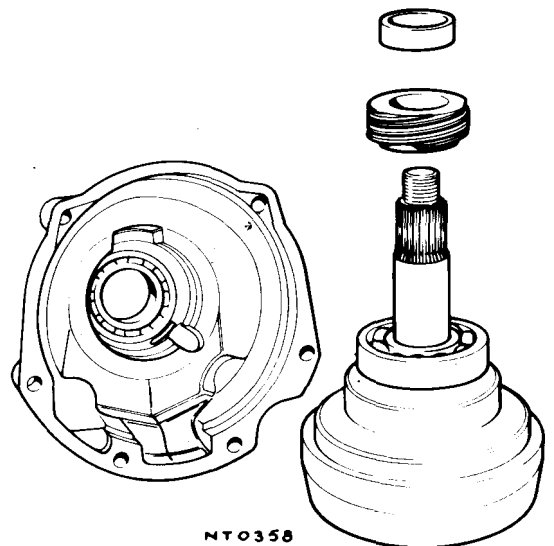
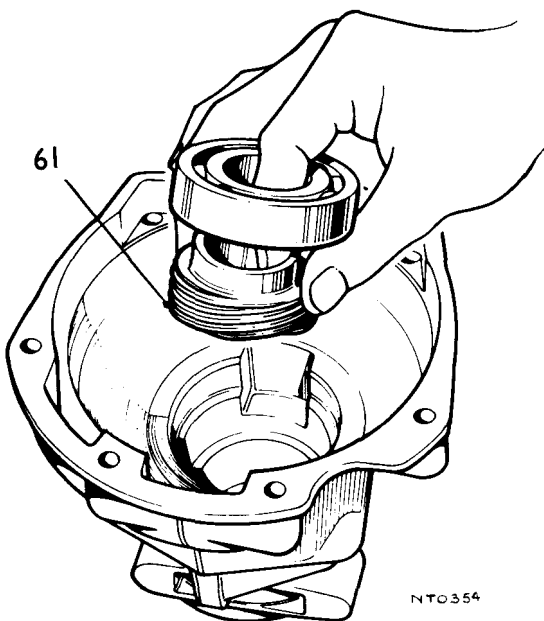
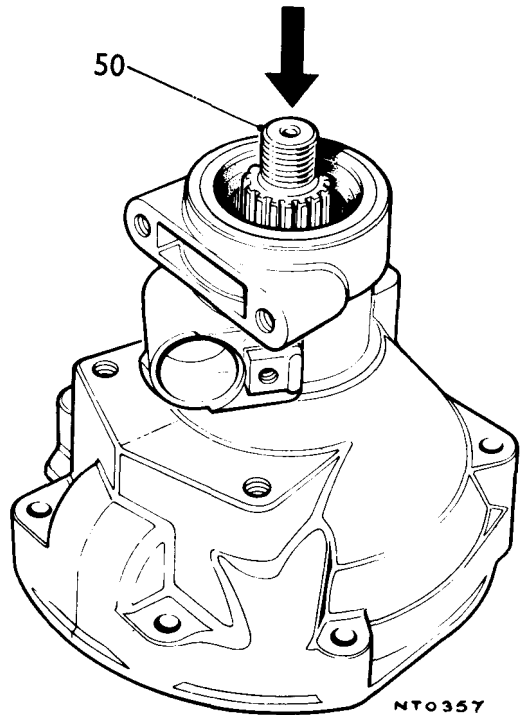

62. Press the front bearing into the rear casing.
63. Ensure that its outer track abuts against the shoulder in the casing.
64. Position the annulus with the inner face resting on a suitable packing piece.
65. Using tool L186, press the front bearing together with the rear casing and speedometer driving gear onto the annulus until the bearing abuts on the locating shoulder.
66. Fit the spacer onto the annulus.
67. Using tool L186, press the rear bearing onto the annulus and into the rear casing simultaneously.
68. Fit the oil seal, using tool L177 with 550.
69. Press on the coupling flange.
70. Fit the washer.
71. Tighten up the self-locking nut to a torque loading of 80 to 130 lbf ft (11.1 to 18.0 kgf m).
72. Position the spring and inner member of the uni-directional roller clutch into the cage.
73. Locate the spring so that the cage is spring loaded in an anti-clockwise direction when viewed from the front.
74. Place the assembly into tool L178, with the open side of the cage uppermost.
75. Move the clutch in a clockwise direction until all the rollers are in place.
76. Refit the bronze thrust washer in the recess in the annulus.
77. Transfer the uni-directional clutch assembly from the special assembly tool into its outer member up the annulus.
78. Position the oil thrower.
79. Secure with the circlip.
80. Check that the clutch rotates in an anti-clockwise direction only.

*continued*

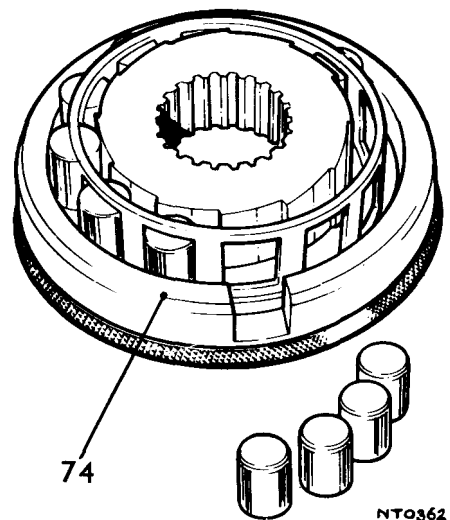
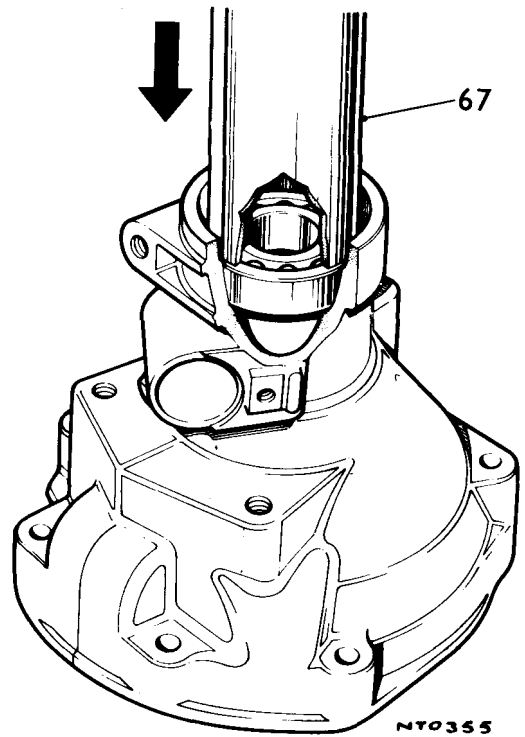

81. Fit the ball race into its housing.
82. Secure the ball race with the large circlip.
83. Position this assembly onto the hub of the cone clutch.
84. Secure with a circlip.
85. Ensure that the circlip locates properly in the groove.
86. Insert the sun wheel into the hub.
87. Fit the circlip on the sun wheel extension.
88. Lightly smear the operating pistons with oil.
89. Fit the pistons into their respective housings.
90. Refit the solenoid control valve. 40.22.09.
91. Refit the pressure filter. 40.10.08.
92. Refit the oil pump assembly. 40.18.01.
93. Refit the pump non-return valve assembly 40.16.10.
94. Refit the relief valve assembly. 40.16.04.

*continued*

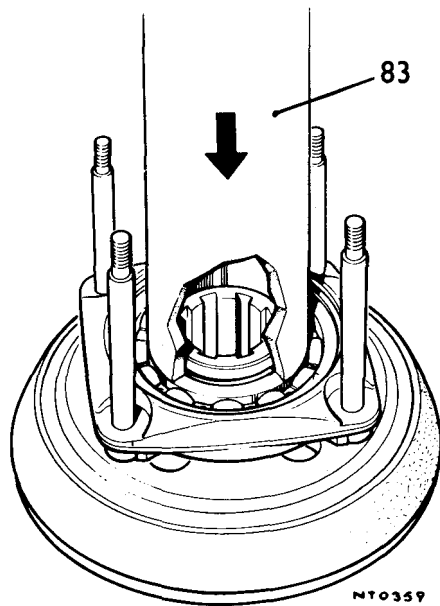

NT0359

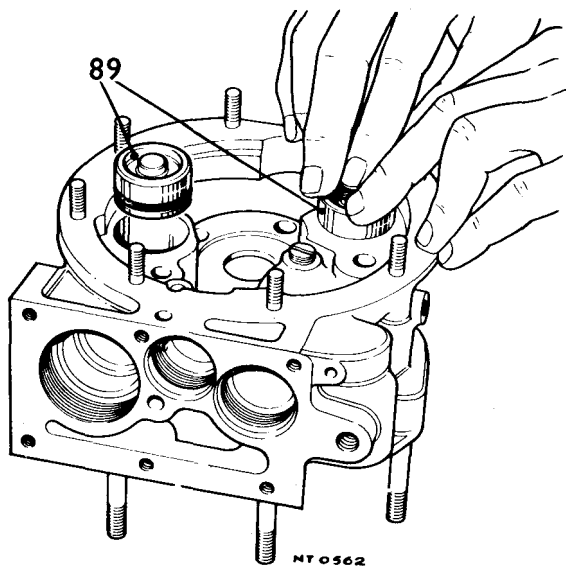

NT0562

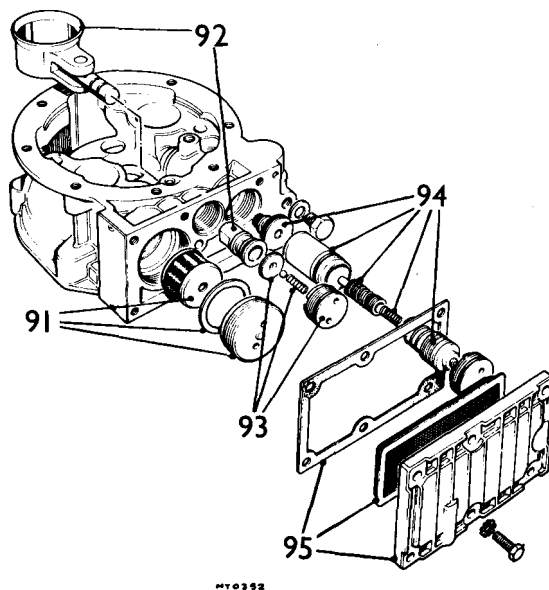

NT0352



95. Refit the sump and suction filter. 40.10.01.
96. Mount the rear casing assembly vertically in a vice.
97. Insert the planet carrier assembly.  
**NOTE:** The gears can be meshed in any position.
98. Place the sliding member assembly complete with the clutch return springs onto the cone of the annulus.
99. Engage the sun wheel with the planet gears.
100. Apply Wellseal to new gaskets either side of the brake ring.  
**NOTE:** These gaskets are different.
101. Fit the brake ring onto its spigot in the tail casing, aligning the stud holes.
102. Position the main casing assembly over the thrust housing pins, at the same time entering the studs in the brake ring.
103. Fit and progressively tighten the six nuts securing the rear and main case assemblies to a torque setting of 13 to 15 lbf ft (1.8 to 2.1 kgf m).
104. Apply Wellseal to the two copper washers and threads of the two top studs.
105. Secure the earth lead to the stud above the solenoid aperture.
106. The clutch return spring pressure will be felt as the two casings go together.
107. Fit the two bridge pieces.
108. Secure with four new self-locking nuts to a torque setting of 6 to 8 lbf ft (0.8 to 1.1 kgf m).

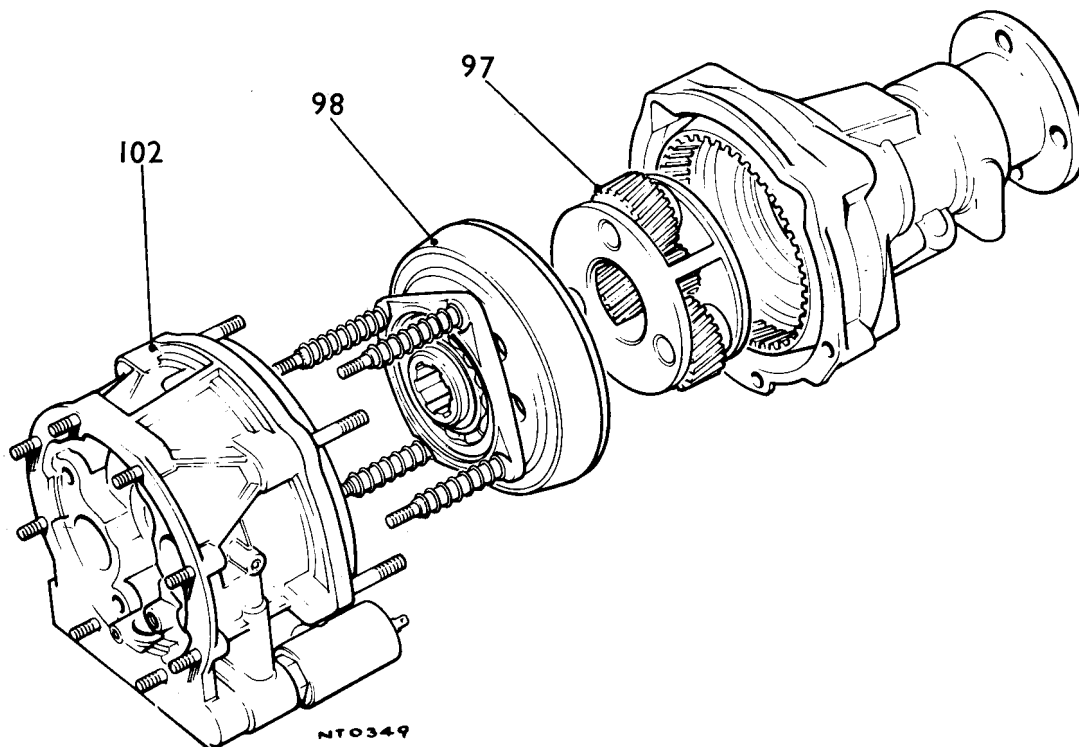

NT0349

## SOLENOID

– Test 40.22.01

1. Connect the solenoid in series with a 12-volt battery and ammeter.
2. The solenoid should draw approximately 2 amps
3. Check that the plunger in the valve moves forward when the solenoid is energized.
4. Check that the plunger in the valve returns to its direct drive position by spring pressure when the solenoid is de-energized.

**NOTE:** The solenoid does not operate with a loud click as the other types of overdrive.

5. If the solenoid is still faulty, the complete unit must be renewed.

## SOLENOID OPERATING VALVE

– Remove and refit 40.22.04

## Removing

1. Disconnect the negative battery lead.
2. Disconnect the two Lucar connectors from the solenoid.
3. Using a 1 in (25 mm) A.F. open-ended spanner on the hexagon, loosen and unscrew the solenoid.

**NOTE:** Do not attempt to remove the solenoid by gripping the cylindrical body as this is very easily damaged.

## Refitting

4. Screw the solenoid into the casing.
5. Tighten with a spanner.
6. Connect Lucar connectors to the terminals; these can be connected either way round.
7. Connect the negative lead of the battery.

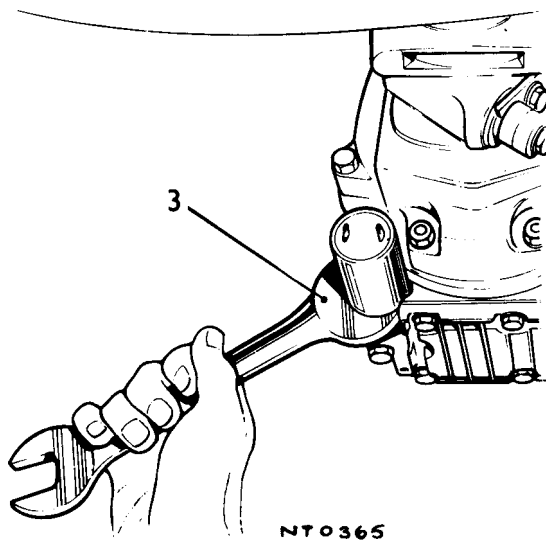

### SOLENOID OPERATING VALVE

— Overhaul 40.22.13

1. Remove the solenoid and operating valve. 40.22.04.
2. Should it be necessary to clean the operating valve, immerse this part of the solenoid valve in paraffin until the valve is clean.
3. Examine the 'O' rings on the solenoid valve for damage, and renew together with a sealing washer if necessary.
4. Fit the solenoid and operating valve. 40.22.04.

### SPEEDO DRIVE GEAR

— Remove and refit 40.25.01

#### Removing

1. Working from under the car, remove the locking plate screw.
2. Remove the drive pinion and holder.

#### Refitting

3. Refit the drive gear, ensuring that the drive gear meshes with the driven gear.
4. Refit the locking plate and screw.
5. Top up any oil lost.

**PROPELLER SHAFT OPERATIONS**

Propeller shaft – remove and refit . . . . .	47.15.01
Universal joint – overhaul . . . . .	47.15.18



PROPELLER SHAFT

– Remove and refit 47.15.01

Removing

1. Place the car on a ramp or over a pit.
2. Remove the exhaust system 30.10.01, with the exception of the front pipes.
3. Mark for reassembly the relationship of the gearbox driving flange to the universal joint flange and remove the four securing nuts and bolts.
4. Mark for reassembly as in instruction 3 and remove the four nuts and bolts securing the rear end of the propeller shaft to the final drive flange and pull the propeller shaft forwards and downwards.

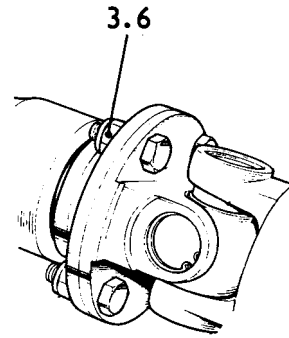

NT2.076

Refitting

5. Offer up the propeller shaft to the final drive flange so that the identification marks line up and secure in position using new nyloc nuts. Tighten the nuts and bolts to 26 to 34 lbf ft (3.6 to 4.7 kgf m).
6. Offer up the propeller shaft to the gearbox flange so that the bolt holes line up and the identification marks coincide. Fit the bolts with new nyloc nuts and tighten as in instruction 5.
7. Reverse instructions 1 and 2.

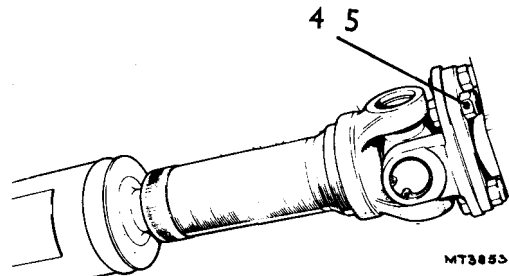

MT3853

# PROPELLER SHAFT

## UNIVERSAL JOINT

– Overhaul

47.15.18

### Dismantling

1. Remove the propeller shaft 47.15.01.
2. Remove the paint, rust etc. from the vicinity of the bearing cups and circlips.
3. Remove the circlips.
4. Tap the yokes to eject the bearing cups.
5. Withdraw the bearing cups and spider.

### Reassembling

6. Remove the bearing cups from the new spider.
7. Ensure that the cups contain approved lubricant (one third full) and that the needle bearings are complete and in position.
8. Fit the spider to the propeller shaft yoke.
9. Engage the spider trunnion in the bearing cup and insert the cup into the yoke.
10. Fit the opposite bearing cup to the yoke and carefully press both cups into position, ensuring that the spider trunnion engages the cups and that the needle bearings are not displaced.
11. Using two flat faced adaptors of slightly smaller diameter than the bearing cups press the cups into the yokes until they reach the lower land of the circlip grooves. Do not press the bearing cups below this point or damage may be caused to the cups and seals.
12. Fit the circlips.
13. Refit the propeller shaft 47.15.01.

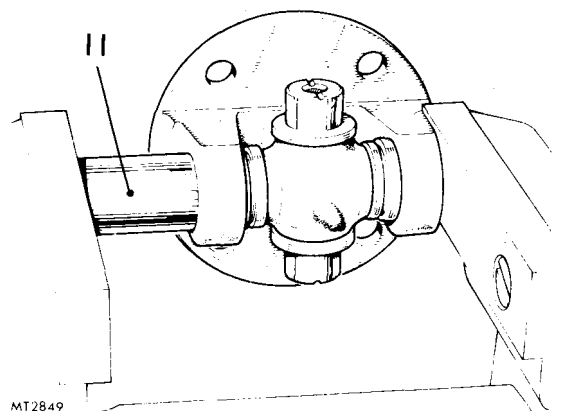
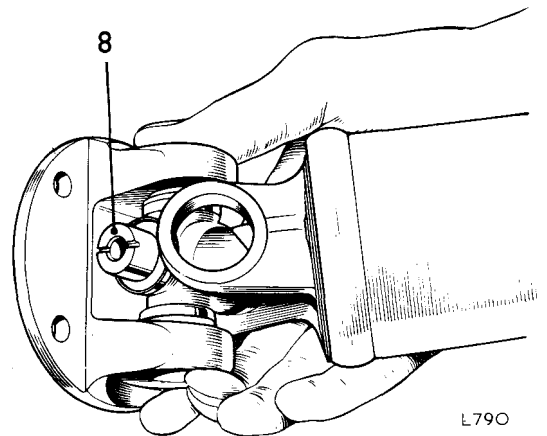
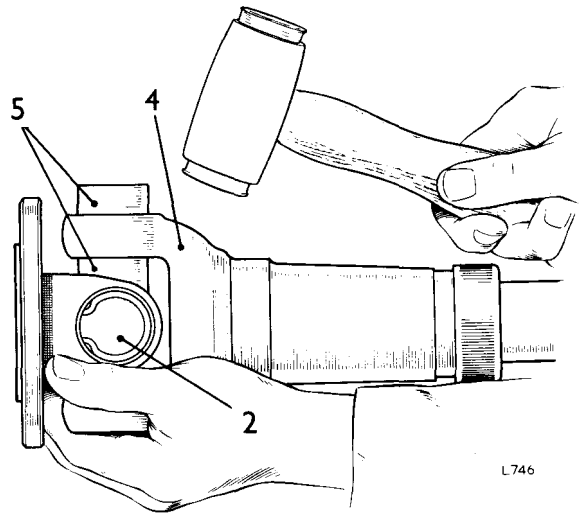

**REAR AXLE OPERATIONS**

Differential – remove and refit . . . . .	51.15.01
Final drive unit mountings – remove and refit . . . . .	51.25.31
Final drive unit – overhaul . . . . .	51.25.19
Hypoid casing – remove and refit . . . . .	51.25.25
Hypoid casing rear cover gasket – remove and refit . . . . .	51.20.07
Inner shaft, bearing, and oil seal – remove and refit . . . . .	51.10.02
Pinion oil seal – remove and refit . . . . .	51.20.01



# REAR AXLE

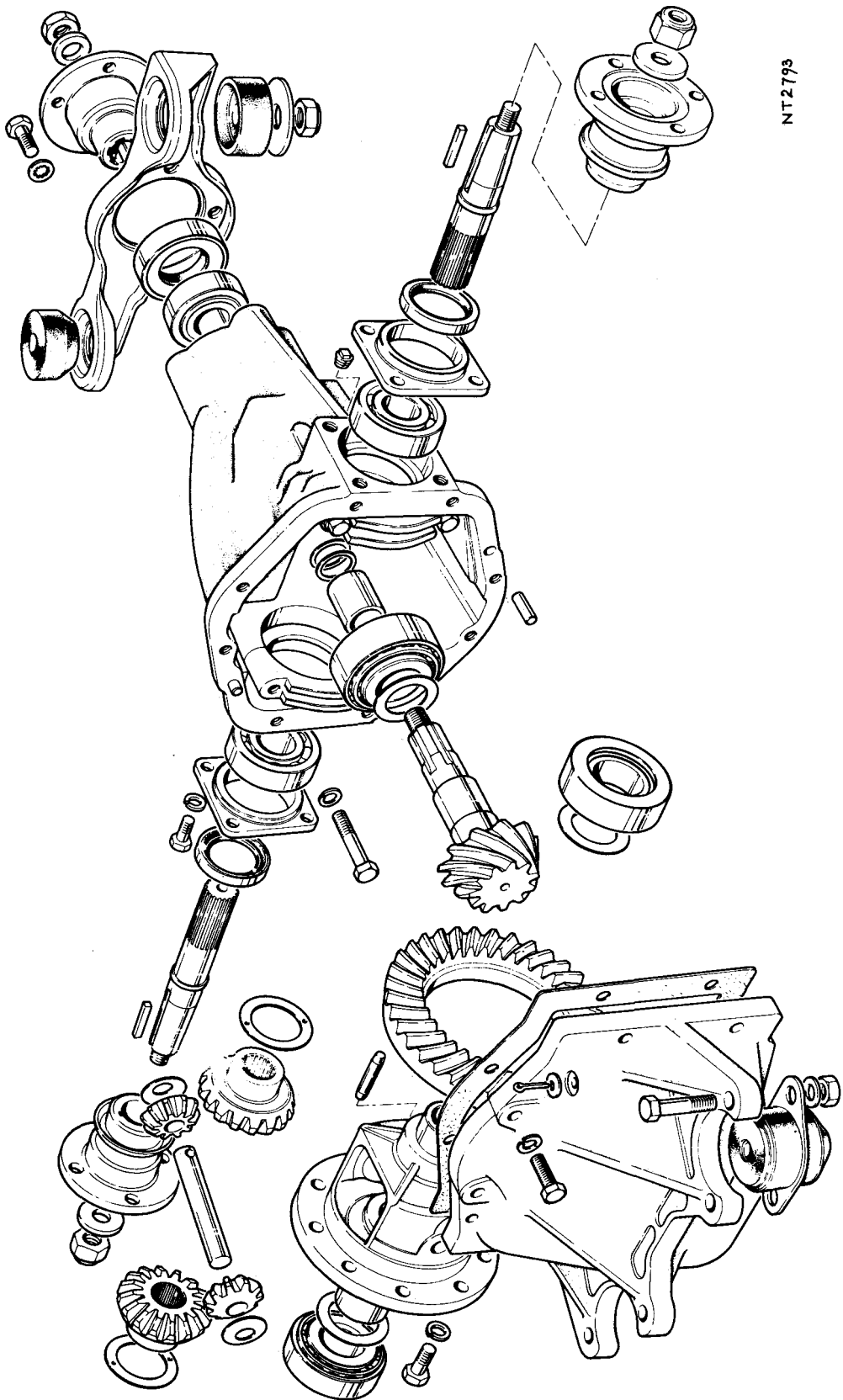

NT2793



**INNER SHAFT BEARING AND OIL SEAL**

– Remove and refit

51.10.02

**Removing**

1. For right hand inner axle shaft, remove exhaust tail box and rear pipes 30.10.19.
2. Disconnect inner drive shaft from flange.
3. Remove four bolts and spring washers securing inner shaft oil seal housing to hypoid casing.
4. Withdraw inner shaft complete with driving flange, oil seal housing and ball race.
5. Remove nyloc nut and plain washer from shaft.
6. Withdraw driving flange, key and oil seal.
7. Remove ball race from shaft.
8. Extract oil seal from housing.

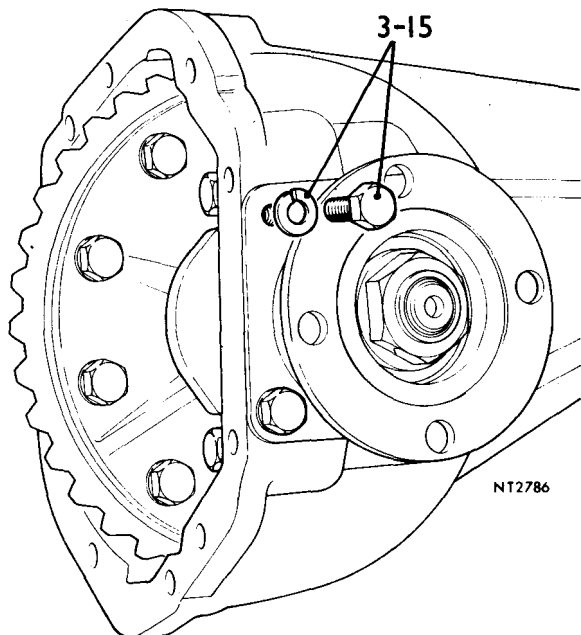

**Refitting**

9. Fit ballrace to shaft until outer face of ball race is approximately aligned with end of shaft taper.
10. Lay oil seal housing flat on bench with the smaller diameter uppermost. Insert oil seal (lip leading) into the housing until the plain face of the seal is flush with the housing.
11. Lubricate lip and slide seal over driving flange (plain face of seal leading). Ensure driving flange deflector seal is undamaged and will not foul the oil seal housing.
12. Fit key, driving flange and oil seal housing to the shaft.
13. Fit the plain washer and the nyloc nut to the shaft. Tighten the nut.
14. Enter the shaft into the hypoid casing engaging the splines in the sun gear.
15. Fit and tighten the four spring washers and bolts securing the oil seal housing to the hypoid casing.
16. Connect up the drive shaft to the inner shaft.
17. For the right hand inner shaft, refit the tail box and rear pipes 30.10.19.
18. Top up the differential unit with oil.

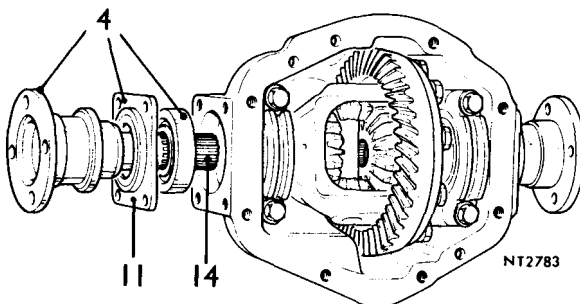
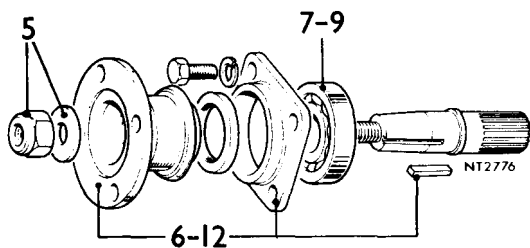
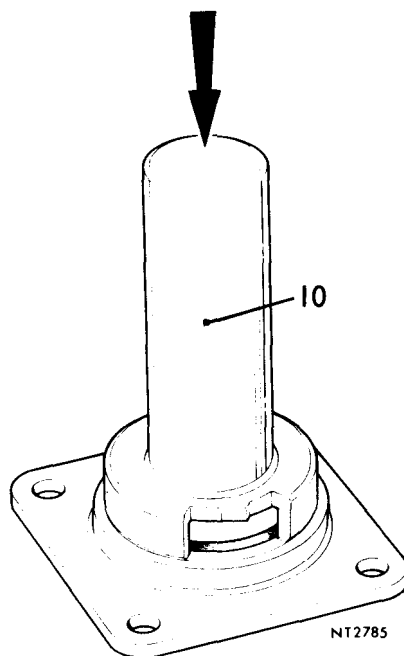

# REAR AXLE

## DIFFERENTIAL

– Remove and refit

51.15.01

Service tools S101

### Removing

1. Remove the hypoid casing from the car 51.25.25.
2. Slacken the eight bolts and spring washers securing the rear cover to hypoid casing and allow oil to drain.
3. Remove the rear cover.
4. Remove the eight bolts (4 either side) securing the inner shaft housing to hypoid casing.
5. Withdraw the inner shafts complete with ballrace oil seal and flanges.
6. Note the location identity markings on carrier bearing caps. Remove four bolts and spring washers securing bearing caps and withdraw bearing caps. Do not intermix the bearing caps.
7. Tap the dowels flush with casing flange.
8. Fit the spreader tool (S101) adaptor plates to hypoid casing.
9. Mount the spreader tool on the adaptor and turn the jacking screw by hand to expand the spreader. A further half turn with a spanner will spread the casing sufficiently to release the differential unit.
10. Lift out the crown wheel and differential unit.

### Refitting

11. Reverse instructions 1 to 10.

**NOTE:** Where the carrier bearing(s) and/or the crown wheel are renewed it is necessary to check the carrier bearing tolerances and the crown wheel/pinion backlash as is detailed under operation number 51.15.13.

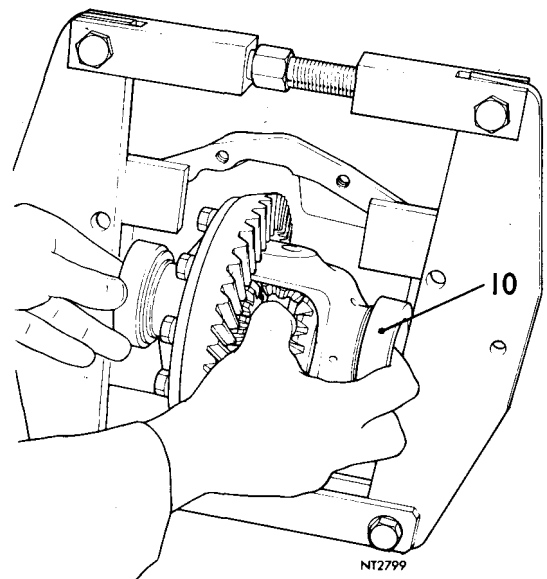
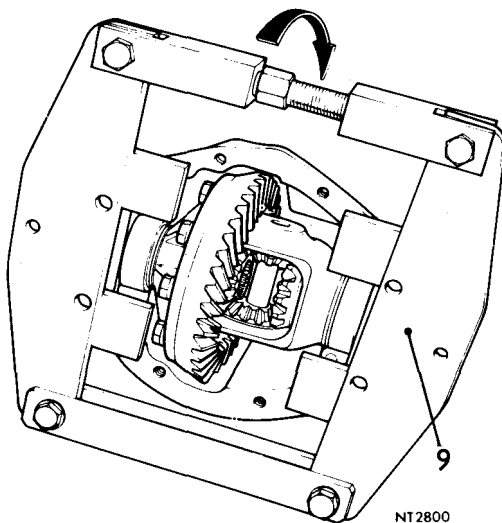
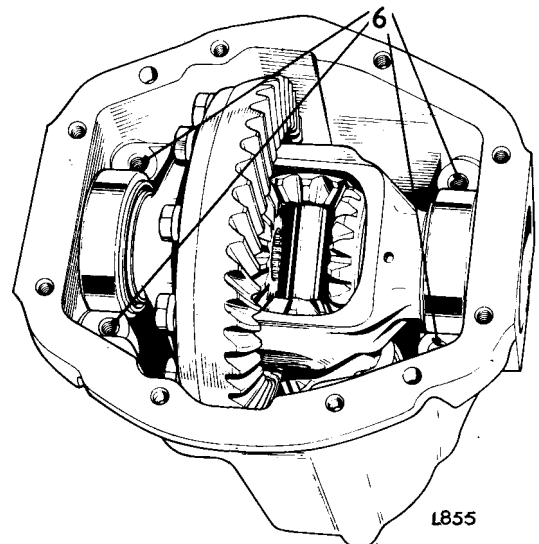
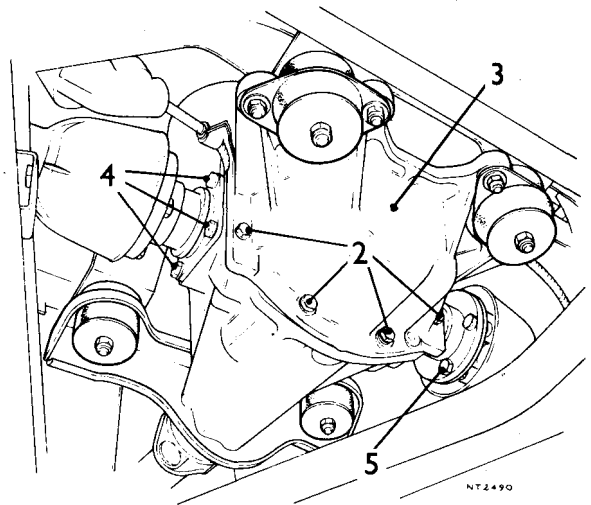

**PINION OIL SEAL**

– Remove and refit

51.20.01

**Removing**

1. Remove the hypoid casing 51.25.25.
2. Remove the drive flange.
3. Withdraw the oil seal.

**Refitting**

4. Fit a new oil seal (lip towards the pinion).
5. Refit the drive flange.
6. Install the hypoid casing 51.25.25.

**HYPOID CASING REAR COVER GASKET**

– Remove and refit

51.20.07

**Removing**

1. Drive the car onto the ramp and raise.
2. Remove the silencer and tail pipes 30.10.19.
3. Support the hypoid casing on a jack and slacken the two nyloc nuts and washers partially releasing the front mountings.
4. Remove the handbrake cable support bracket from the hypoid casing.
5. Remove the two rear mounting nuts.
6. Lower the jack and axle.
7. Remove the four nuts, bolts and spring washers and remove the two mounting rubbers.
8. Place a drip tray under the hypoid unit.
9. Slacken the seven bolts securing the rear cover to the hypoid casing. Ease the cover from the casing and allow the oil to drain.
10. Remove the cover.
11. Remove the gasket and clean the mating faces.

**Refitting**

12. Fit a new gasket and assemble the cover to the hypoid casing (seven bolts).
13. Place the four rear mounting bolts in the cover.
14. Raise the jack under the hypoid and locate the mounting rubbers to the studs.
15. Locate the rear mounting rubbers to the four mounting bolts in the rear cover and fit the four spring washers and nuts.
16. Fit the two plain washers and nyloc nuts.
17. Tighten the four nyloc nuts securing the front and rear rubber mountings.
18. Lower the jack.
19. Refit the handbrake support bracket.
20. Refill the hypoid casing with new oil.
21. Refit the silencer and tail pipes 30.10.19.
22. Lower the ramp and drive the car off.

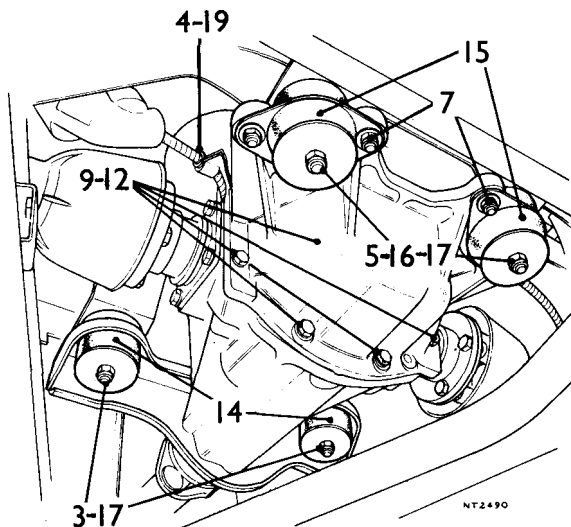

# REAR AXLE

## FINAL DRIVE UNIT

– Overhaul

51.25.19

Service Tools: S4221A-10-16, RG421, S123A, M84B-1, S316

**NOTE:** If slight damage to the crown wheel or the pinion necessitates replacement, discard both items and fit a new matched pair. These gears are lapped together during manufacture and etched with similar marking to identify them as a pair, therefore, before fitting, ensure that each gear is similarly marked as shown in NT 2784.

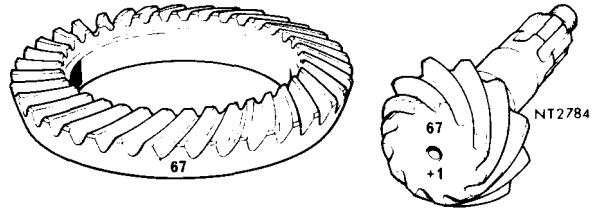

### Dismantling

1. Withdraw crown wheel and differential unit from hypoid casing 51.15.01.
2. Remove the ten bolts and washers securing the crown wheel to the differential flange, withdraw the crown wheel.
3. With the crown wheel removed, install the differential unit in the hypoid casing and release all tension from the spreading tool.
4. Using a dial gauge check the crown wheel flange run-out, this should not exceed 0.003 in (0.08 mm). Excessive run out indicates a distorted crown wheel flange, differential or defective bearings.
5. Remove the differential unit from the hypoid casing.
6. Using the tools S4221A-10, withdraw the differential carrier bearings.

*Continued*

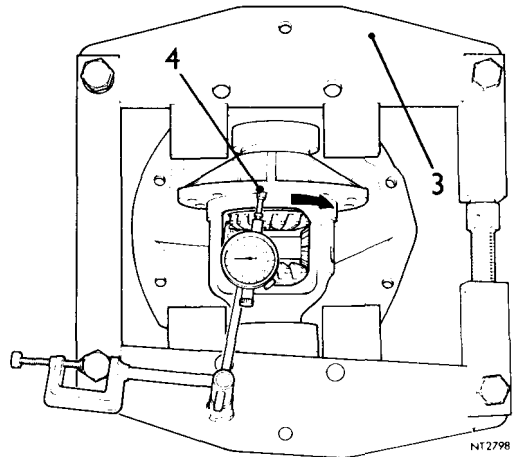
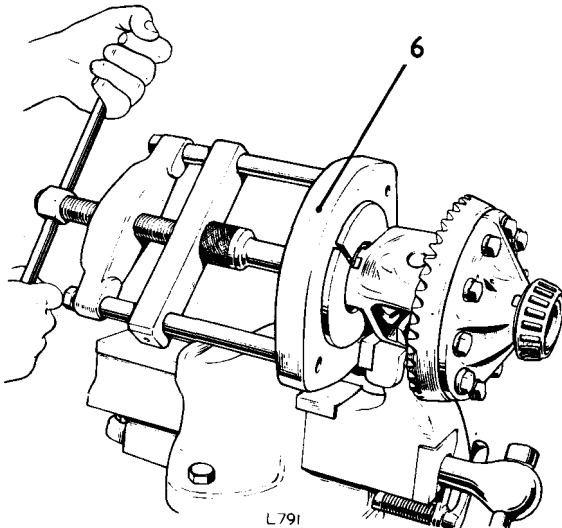

7. Drift out the cross shaft locking pin and the cross shaft.
8. Rotate the sun gears through 90° and extract the planet gears and thrust washers.
9. Withdraw the sun gears and thrust washers.
10. Remove the locking wire from the pinion shaft.
11. Using tool RG421 or S316 to hold the flange, remove the castellated nut and washer. Withdraw the flange.

\*\* NOTE: Earlier units are fitted with a nyloc nut, Later units are fitted with a wired castellated nut. \*\*

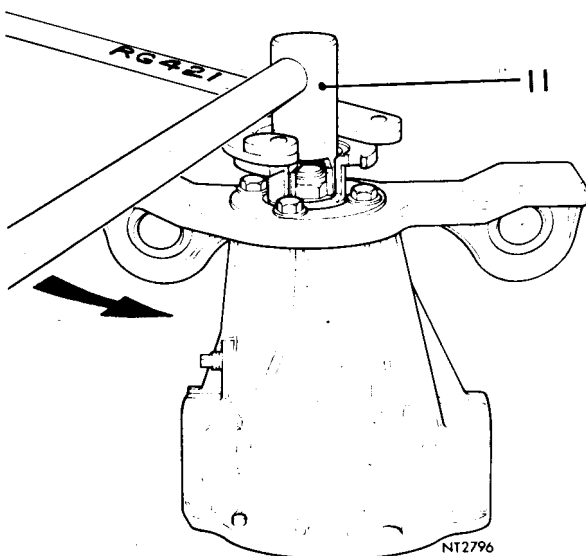
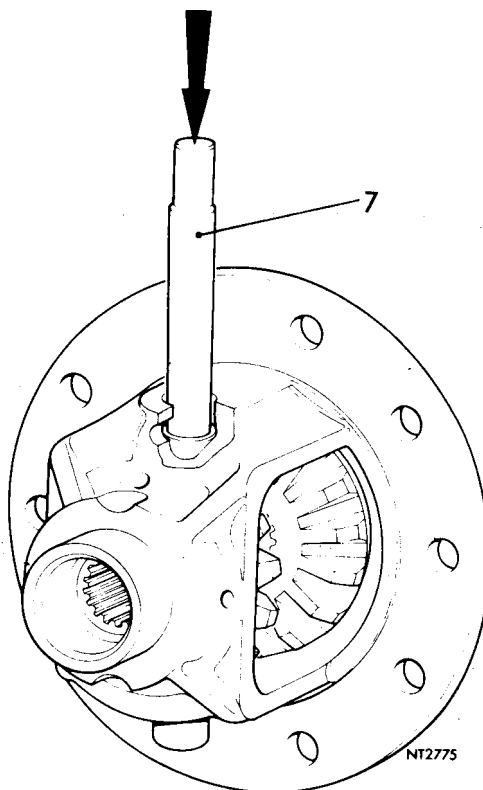
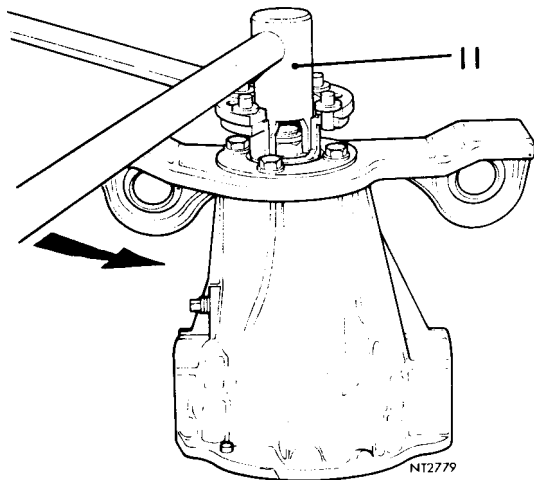
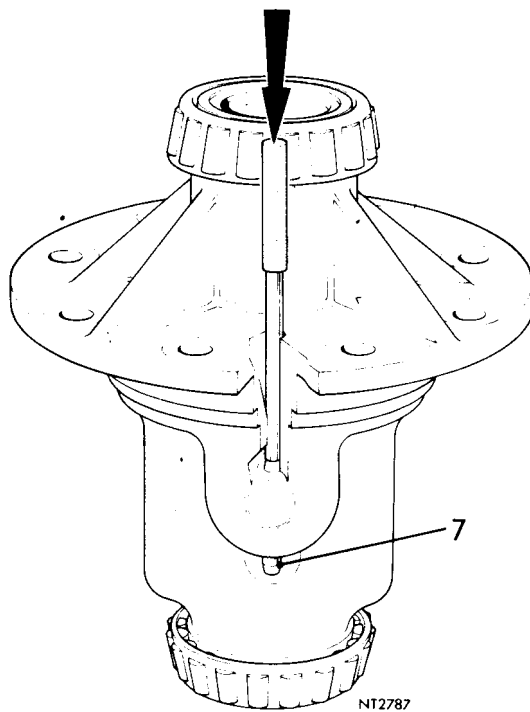

12. Remove the four bolts securing the front mounting bracket.
13. Remove the bracket.
14. Carefully drive out the pinion shaft complete with the inner bearing, bearing spacer and shim pack.
15. Extract the seal and the outer bearing.

*Continued*

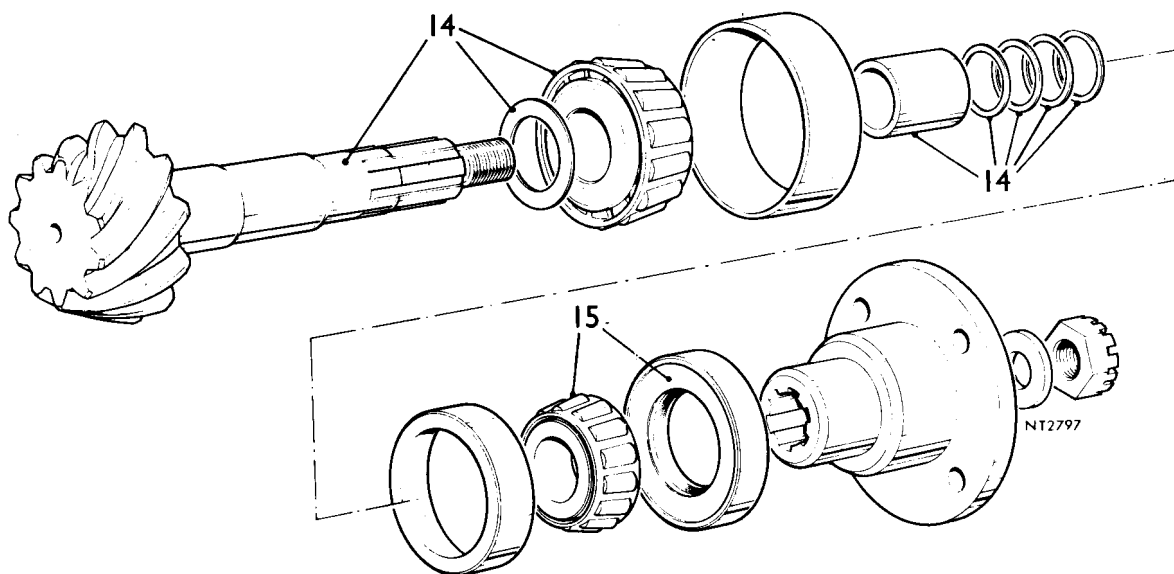
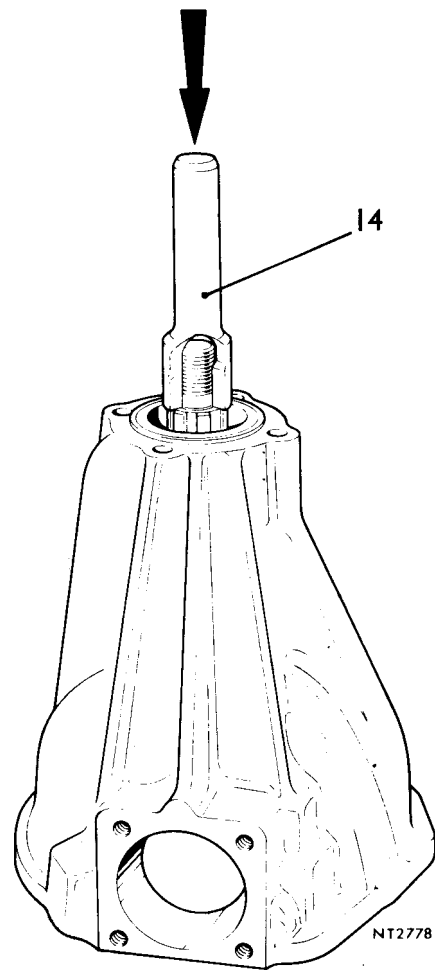

16. Remove the pinion shaft bearing outer tracks from the hypoid casing using tool S123A.
17. Using tool 4221A-16, install the pinion bearing outer tracks in the hypoid casing.

*Continued*

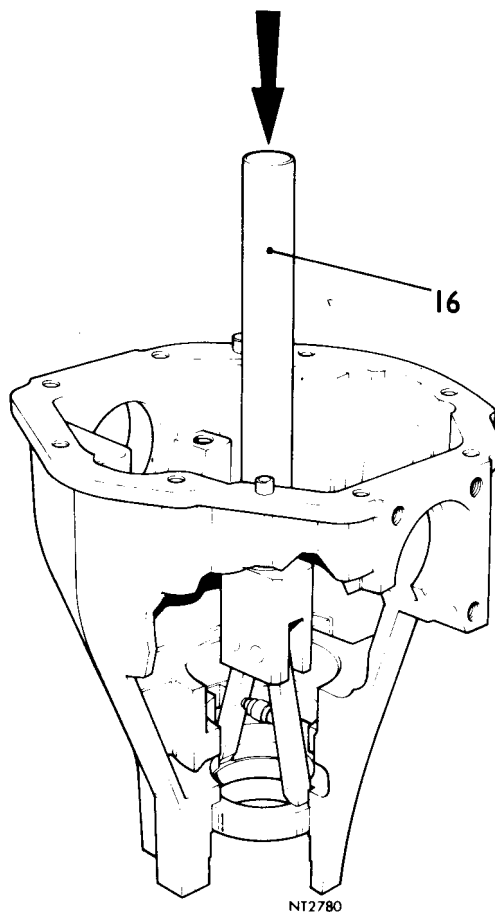

NT2780

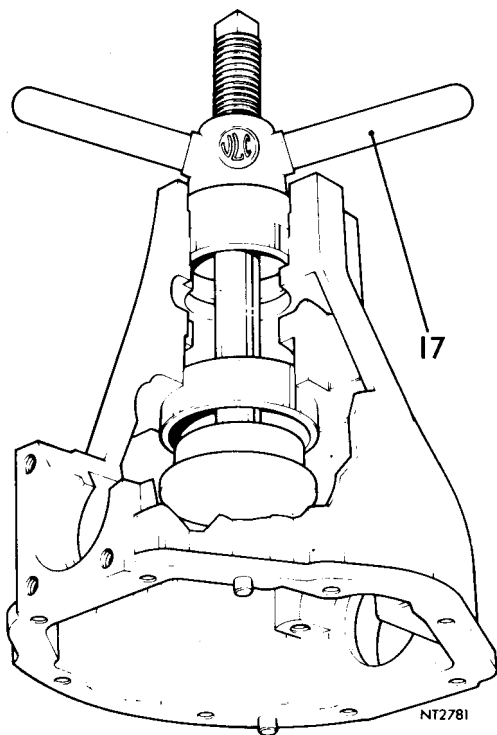

NT2781

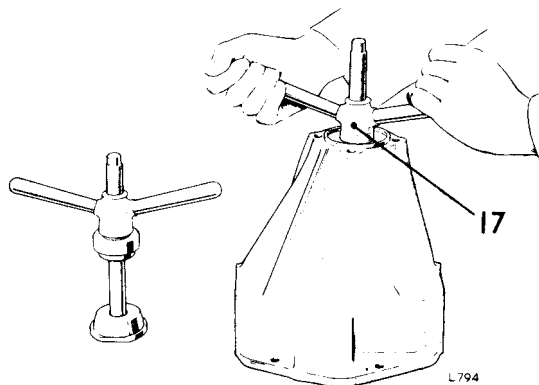

L794

## REAR AXLE

18. Install the pinion head bearing on the dummy pinion (tool M84B-1) and assemble it in the hypoid casing.
19. Fit the pinion tail shaft bearing, centralizing collar, flange, plain washer and slotted nut.
20. Tighten the slotted nut until a torque of 15 to 18 lbf in (0.17 to 0.21 kgf m) will just turn the pinion.
21. Set the pinion gauge (tool 84B) to zero.
22. Install the gauge and the dummy bearings in the hypoid casing.

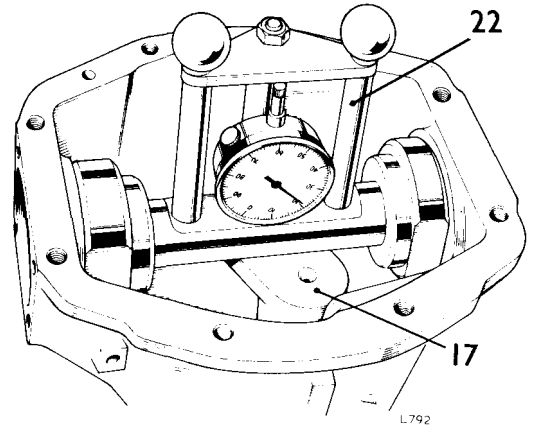

23. Maintaining slight pressure on the gauge body, rock the stylus across the dummy pinion, observe the gauge readings. The minimum value is recorded when the stylus is parallel to the axis of the dummy pinion. This value is the thickness of the shim(s) to be fitted between the pinion and the pinion head bearing.
24. Remove the gauge and the dummy pinion from the hypoid casing.
25. Fit the four bolts holding the mounting flange to the hypoid case 15 to 20 lbf in (2.1 to 2.8 kgf m).
26. Fit the required shim(s) to the pinion shaft and fit the pinion head bearing.
27. Install the pinion in the hypoid casing.
28. Fit the bearing spacer, tail shaft bearing drive flange, plain washer and castellated nut.

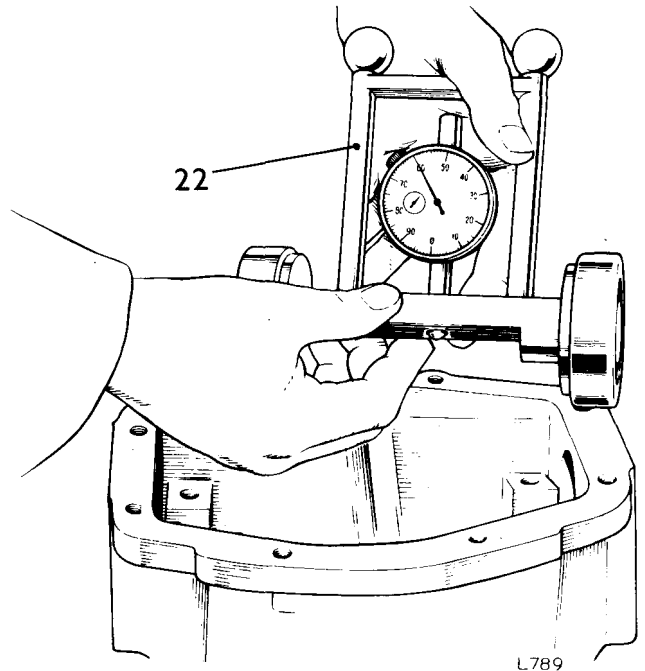

**NOTE:** Ensure that the tapered face of the bearing spacer is fitted adjacent to the tailshaft bearing.

29. Carefully tighten the castellated nut checking the pinion bearing pre-load. Shim the bearing spacer as is necessary to obtain a pinion torque of 15 to 18 lbf in (0.17 to 0.21 kgf m) when the castellated nut is tight to a torque loading of 90 to 120 lbf in (12.4 to 16.6 kgf m).
30. Remove drive flange.
31. Press the oil seal into the hypoid casing (lip towards the pinion).
32. Refit drive flange and nut to a loading of 90 to 120 lbf in (12.4 to 16.6 kgf m).
33. Fit the locking wire to the castellated nut.

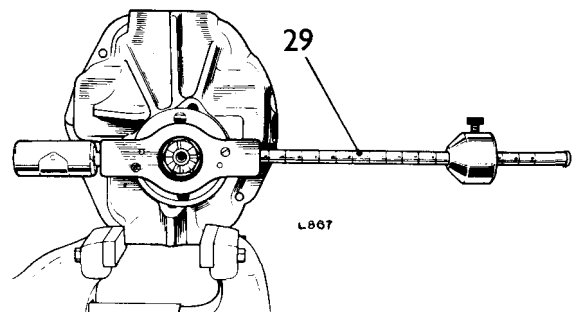

*Continued*



34. Fit the thrust washers to the sun gears and slide these into the differential housing.
35. Assemble the thrust washers to the planet gears and mesh the planet gears with the sun gears (planet gears opposite each other).
36. Rotate the sun gears and slide both planet gears and thrust washers into position in the differential unit.
37. Insert the planet gear cross shaft.
38. Select and fit planet gear thrust washer as required to obtain zero backlash.
39. Fit the locking pin to the cross shaft and lightly peen to secure.
40. Fit the carrier bearing inner cones to the differential unit. Do not install any shims at this stage.
41. Refit the hypoid case spreader tool 51.15.01 operations 8 and 9.
42. Fit the outer bearing tracks to the cones and install the differential in the hypoid casing. Do not fit the bearing caps.
43. Using a dial gauge, check the total axial movement of the crown wheel flange. To the measurement obtained, must be added 0.003 in (0.0762 mm) carrier bearing pre-load. Thus the total amount of shims to be fitted to the carrier bearings is free movement + 0.003 in (0.0762 mm).
44. Remove the differential unit and fit crown wheel — 10 bolts and spring washers 38 to 46 lbf (5.2 to 6.4 kgf m), \*\* apply loctite to bolts before fitting. \*\*
45. Again install the differential unit in the hypoid housing.
46. Using a dial gauge check the total axial movement. This represents the crown wheel movement, zero backlash to maximum backlash. Subtract an operational backlash of 0.004 to 0.006 in (0.1016 to 0.1524 mm) from the gauge reading. From these two dimensions can be found bearing shim thickness and location i.e.  
 Instruction 43. Total float WITHOUT crown wheel PLUS 0.003 in (0.0762 mm) bearing pre-load and  
 Instruction 46. Total float WITH crown wheel MINUS required backlash 0.004 to 0.006 in (0.1016 to 0.1524 mm). \*\*
47. Remove the carrier bearing adjacent to the crown wheel from the differential unit and select the shim pack to the value of instruction 46 (the total float with the crown wheel minus 0.004 to 0.006 in (0.1016 to 0.1524 mm)). Fit this shim pack to the bearing.
48. Remove the carrier bearing farthest from the crown wheel. Subtract the dimension in instruction 46 from the dimension in instruction 40. Select the shim pack and fit the shims and bearing to the differential unit.

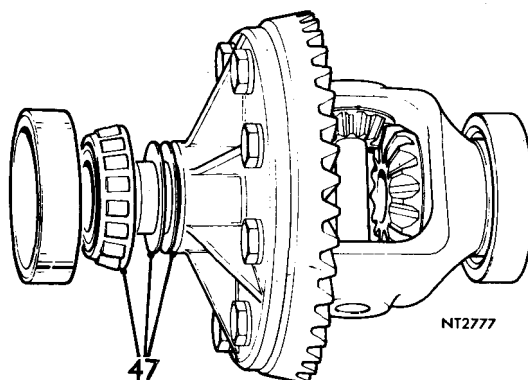
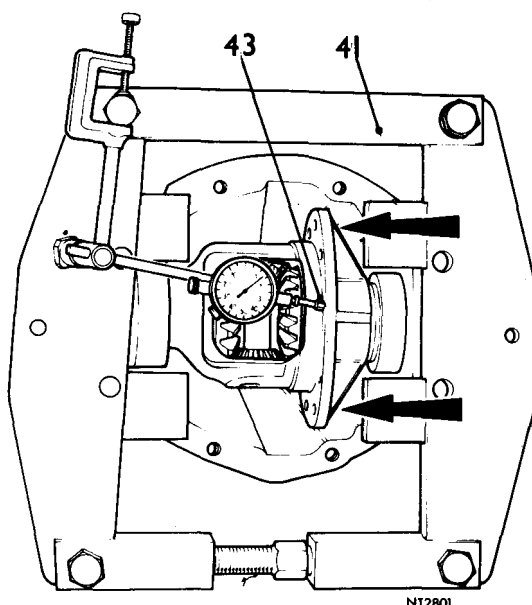

Continued

## REAR AXLE

---

49. Insert the differential unit into the hypoid casing. Release the spreading tool and fit and tighten carrier bearing caps to a torque of 30 to 38 lbf in (4.1 to 5.2 kgf m).
50. Using a dial gauge, check the backlash at several points on the crown wheel if a mean reading of 0.004 to 0.006 in (0.1016 to 0.1524 mm) is not obtained, transfer shims from one carrier bearing to the other as required.
51. Refit a new rear cover gasket.
52. Tap the locating dowels back proud of the hypoid case.
53. Refit the rear cover (seven bolts).
54. Refit the hypoid casing to the car 51.25.25.

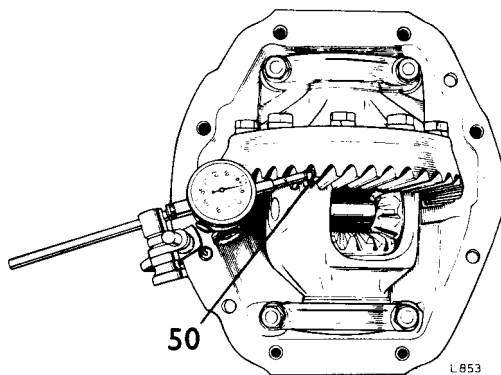

**HYPOID CASING**

– Remove and refit

51.25.25

**Removing**

1. Raise the car on a ramp, support the body on stands and locate a jack under the hypoid casing.
2. Remove exhaust tail box and rear pipe complete 30.10.19.
3. Roll back the rubber dust shields.
4. Disconnect the drive shafts from the inner axle shafts and propeller shaft from the pinion flange, four nuts and bolts on each.
5. Disconnect the nearside handbrake cable bracket, one bolt to the hypoid case.
6. Remove four nuts (two front mountings, two rear mountings) and heavy plain washers. Remove rubbers from front mountings only.
7. Carefully lower the jack until the two rear mountings are clear of the two chassis mounted studs.
8. Carefully withdraw the hypoid casing to the rear of the car, taking care not to damage the petrol pipes or brake fluid pipes.

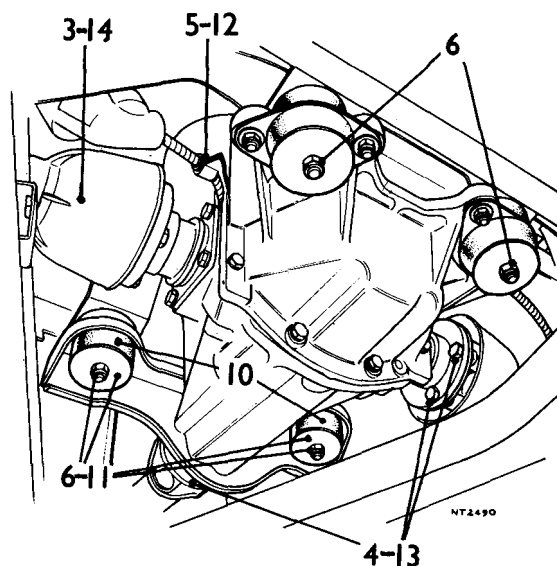

**Refitting**

9. Carefully reposition the hypoid casing over the chassis studs.
10. Refit the rubbers over the front mountings.
11. Refit four heavy plain washers and nuts.
12. Connect up the nearside handbrake cable bracket to the hypoid housing.
13. Connect up the drive shafts to the inner axle shafts and the propeller shaft, four nuts and bolts on each.
14. Reposition the rubber dust shields over the universal joints.
15. Refit the exhaust tail box and rear pipes complete 30.10.19.
16. Remove the stands and lower the ramp.

### FINAL DRIVE UNIT MOUNTINGS

– Remove and refit

51.25.31

#### Removing

1. Remove the hypoid casing from the car 51.25.25.
2. Remove the four nuts, bolts and spring washers securing the two rear mountings to the rear cover.
3. Remove the rear mountings.
4. Remove the two upper front rubber mountings from the chassis studs.

#### Refitting

5. Refit the two upper front rubber mountings to the chassis studs.
6. Refit the four nuts, bolts and spring washers securing the two rear rubber mountings to the rear cover.
7. Refit the hypoid casing to the car 15.25.25.

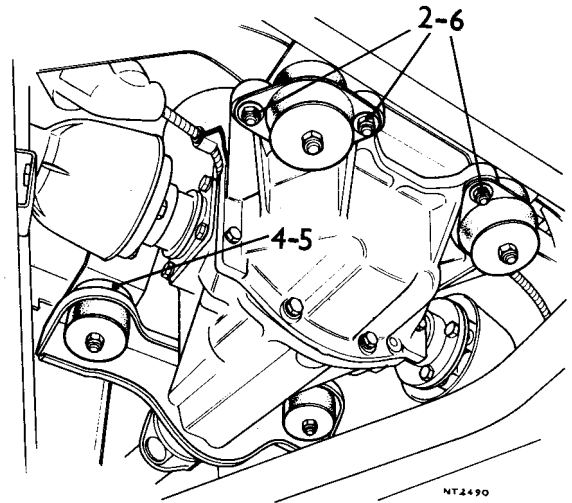

**STEERING OPERATIONS**

Camber angle – check and adjust . . . . .	57.65.05
Front wheel alignment – check and adjust . . . . .	57.65.01
Intermediate shaft – remove and refit . . . . .	57.40.22
– lower coupling – remove and refit . . . . .	57.40.27
– upper coupling – remove and refit . . . . .	57.40.26
Steering column assembly – remove and refit . . . . .	57.40.01
– bushes – remove and refit . . . . .	57.40.18
– lock/ignition/starter switch – remove and refit . . . . .	57.40.31
– lower column – remove and refit . . . . .	57.40.05
– upper column – remove and refit . . . . .	57.40.02
Steering geometry . . . . .	57.65.00
Steering rack and pinion – remove and refit . . . . .	57.25.01
– gaiters – remove and refit . . . . .	57.25.02
– overhaul . . . . .	57.25.07
– damper – remove and refit . . . . .	57.35.10
Steering wheel – remove and refit . . . . .	57.60.01
– hub – remove and refit . . . . .	57.60.02
Tie rod ball joint – inner – remove and refit . . . . .	57.55.03
– outer – remove and refit . . . . .	57.55.02



STEERING RACK AND PINION

– Remove and refit

57.25.01

Service Tool: S341

Removing

1. Jack up the car and remove the front road wheels.
2. Disconnect the tie rod outer ball joints from the steering arms.
3. Remove the bolt, plain washer and nut securing the universal joint to the rack pinion.
4. Remove the plug from the damper plug and release the bonding strap.
5. Remove the four nuts, plain washers and two angle plates securing the rack 'U' bolts to the chassis.
6. Withdraw the 'U' bolts and bracket assemblies.
7. Slide the rack forward to release the pinion from the universal joint.
8. Remove the rack.
9. Remove the rack mounting rubbers.

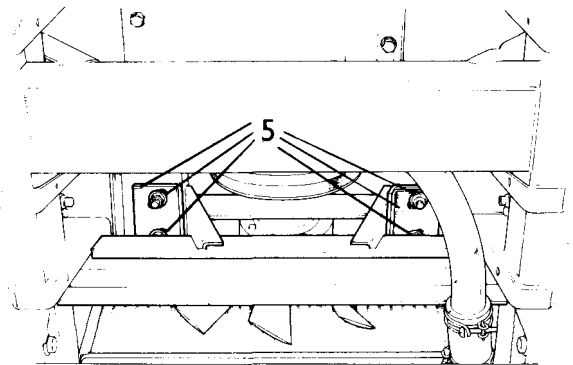
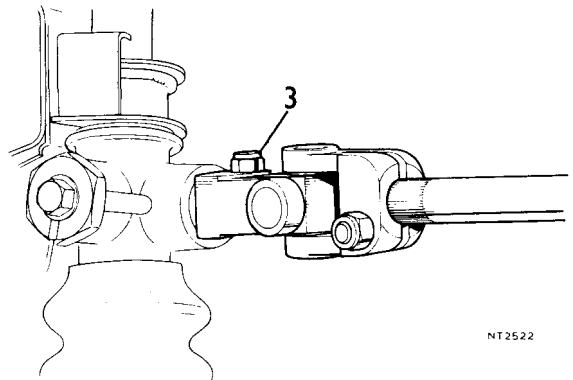
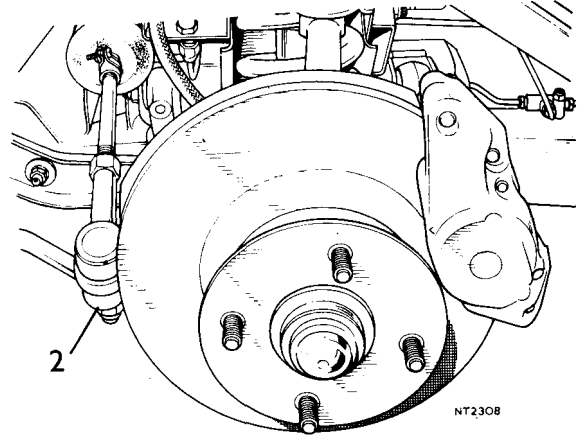

Refitting

10. Fit the rack mounting rubbers on the inboard side of the rack flanges. Ensure the lip of the mountings engages the straight edges of the flanges.
11. Centralise the steering rack and place it in position on the chassis.
12. With the steering wheel centred engage the pinion in the universal joint.
13. Fit the 'U' bolt and bracket assemblies.
14. Fit the angle plates (angles inboard) plain washers and nuts to the 'U' bolts.
15. Using Tool S341, compress the mounting rubbers until approximately 1/8 in. (3 mm) remains exposed beyond the edge of the 'U' bolt brackets.
16. Ensure that the angle of the plates is in hard contact with the chassis and tighten the 'U' bolt nuts. Remove Tool S341.
17. Connect the tie rod ball joints to the steering arms.
18. Fit the clamp bolt, plain washer and nut to the universal joint and pinion. Tighten.
19. Fit the bonding strap and plug to the damper plug.
20. Fit the front wheels and remove the jack.
21. Check and adjust front wheel track.

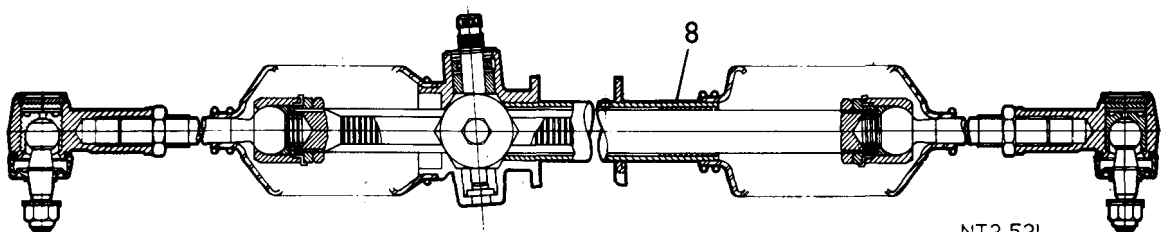

## STEERING

### STEERING RACK GAITERS

– Remove and refit

57.25.02

#### Removing

1. Remove the tie rod outer ball joints 57.55.02.
2. Remove the inner and outer clips securing the gaiters to the steering rack and the tie rods respectively.
3. Withdraw the gaiters.

#### Refitting

4. Lubricate the tie rod inner ball joints with fresh grease.
5. Slide the new gaiters complete with clips along the tie rods into position on the rack.
6. Fit the inner clips to the gaiters and the rack housing.
7. Fit the locknuts and outer ball joints to the tie rods.
8. Secure the outer ball joints to the steering arms and fit the road wheels.
9. Adjust the front wheel track and tighten the outer ball joint locknuts.
10. Tighten the outer clips on the gaiters ensuring that the gaiters are positioned to accommodate lock to lock movement of the tie rods.

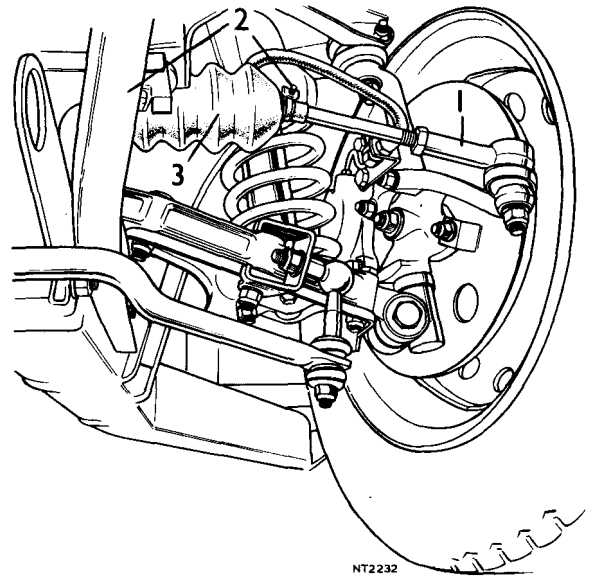

### STEERING RACK AND PINION

– Overhaul

57.25.07

1. Slacken the locknuts securing the tie rod outer ball joints.
2. Remove the rack from the car 57.25.01

#### Dismantling

##### Rack plunger

3. Unscrew the plug securing the rack plunger to the rack housing.
4. Remove the plug and shims.
5. Withdraw the spring and plunger.

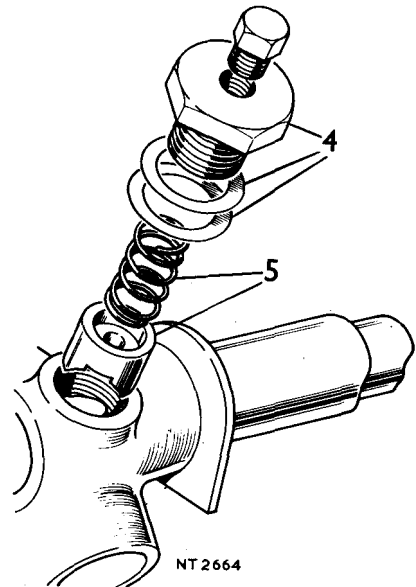

##### Pinion

6. Remove the circlip retaining the pinion to the rack housing.
7. Withdraw the pinion complete with plug end, locating pin, shims, bush and upper thrust washer.

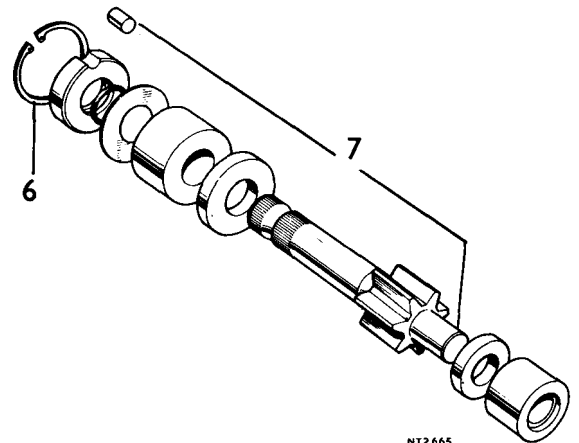

*Continued*

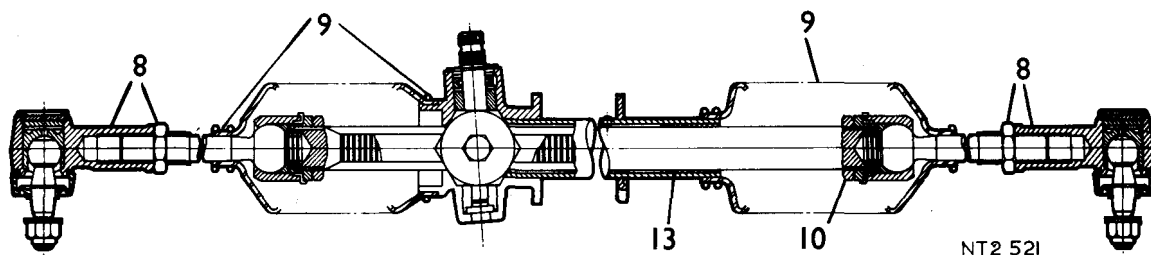

**Tie rods and rack shaft**

8. Remove the outer ball joints and locknuts.
9. Slacken the clips securing the gaiters to the rack housing and tie rods and remove the gaiters.
10. Slacken the locknuts securing the inner ball joint adaptors to the rackshaft.
11. Unscrew and remove the inner ball joint adaptors complete with tie rods and inner ball joint springs.
12. Remove the rack shaft locknuts and withdraw the rack shaft.

**Rack housing bush**

13. Remove the bush from the rack housing. (Fitted at end opposite to pinion location).

**Pinion housing**

14. Withdraw the pinion lower thrust washer.
15. Drive or press out the pinion end cover and the lower bush.

**Assembling**

**Rack housing bush**

16. Fit a new bush to the rack housing.

**Pinion housing**

17. Fit the end cover and the lower bush to the pinion housing ensuring that the recessed end of the bush is fitted adjacent to the end cover.

**Rack shaft and tie rods.**

18. Insert the pinion lower thrust washer in position above the pinion lower bush ensuring that the internal fillet faces away from the bush.
19. Insert the rack shaft in the housing ensuring that rack teeth are fitted to pinion end of housing.
20. Fit the locknuts to the rack shaft.
21. Fit both tie rods, springs and adaptors and secure with locknuts. (torque 80 lbf ft. – 11.1 kgf m).
22. Pack the inner ball joints with grease and fit the gaiters and clips.

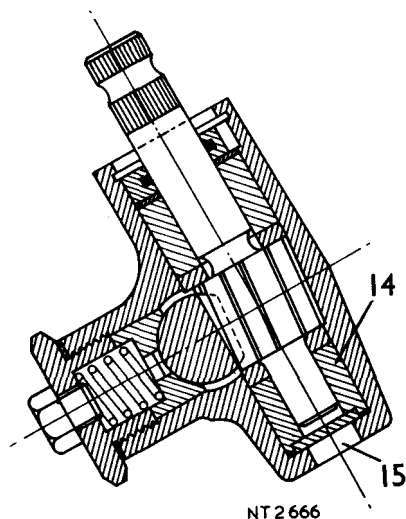
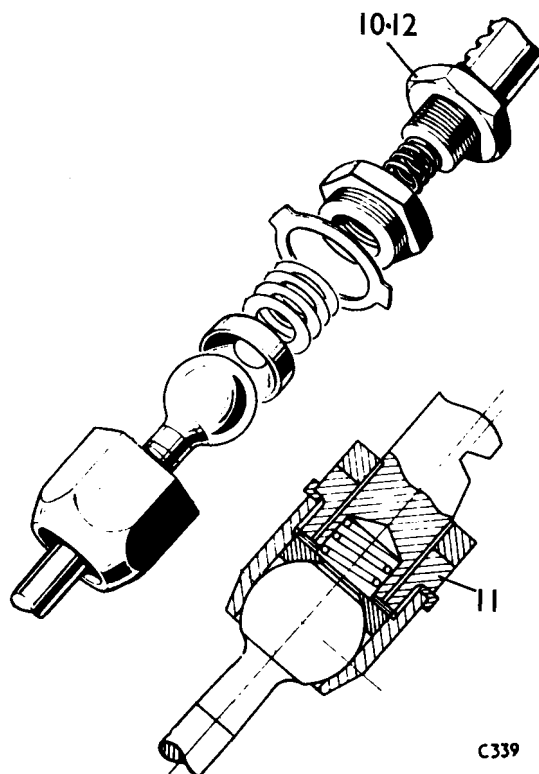

*Continued*



# STEERING

## Pinion

23. Rotate the rack shaft until rack teeth will permit pinion engagement.
24. Engage the pinion in the pinion housing and rack shaft.
25. Fit the upper thrust washer, bush and shims.
26. Fit a new internal 'O' ring to the plug-end and fit the plug-end and locating pin.
27. Fit the circlip and check the pinion for end-float. End-float must not exceed 0.010 in (0.254 mm). Adjust the shim pack as necessary.

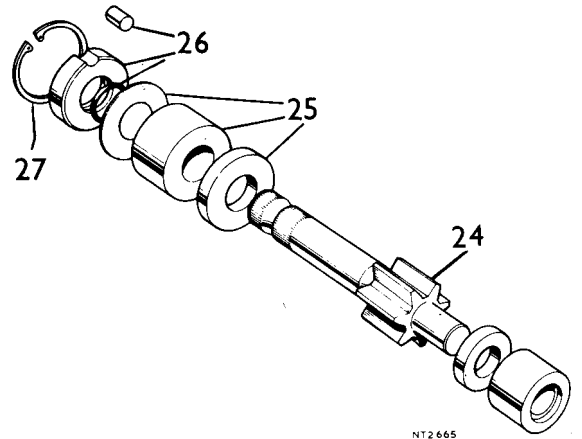

## Rack plunger

28. Fit the plunger.
29. Fit the spring, shims and damper plug.
30. Check the rack shaft for side movement (90° to shaft axis). Side movement should be within 0.004 to 0.008 in (0.102 to 0.203 mm). Adjust as required by adding or removing shims as required.

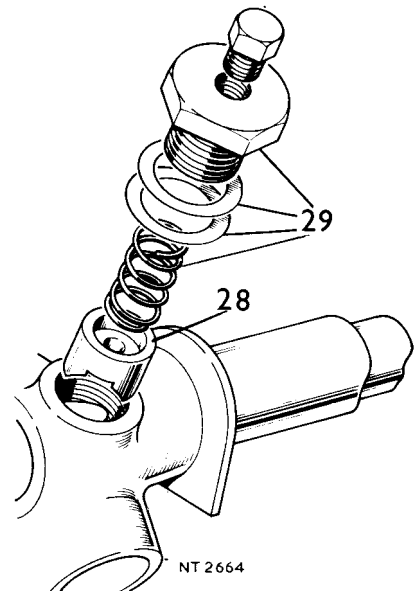

## STEERING RACK DAMPER

– Remove and refit

57.35.10

### Removing

1. Disconnect the bonding strap at the damper plug.
2. Unscrew the damper plug and withdraw plug, shims, spring and plunger.

### Refitting

3. Fit the plunger and spring.
4. Fit the shims and damper plug. Tighten the plug.
5. Check the rack shaft for movement (90° to rack axis). Side movement should be within 0.004 to 0.008 in (0.102 to 0.203 mm). Adjust as required by adding or removing shim(s) as necessary.
6. Connect the bonding strap.

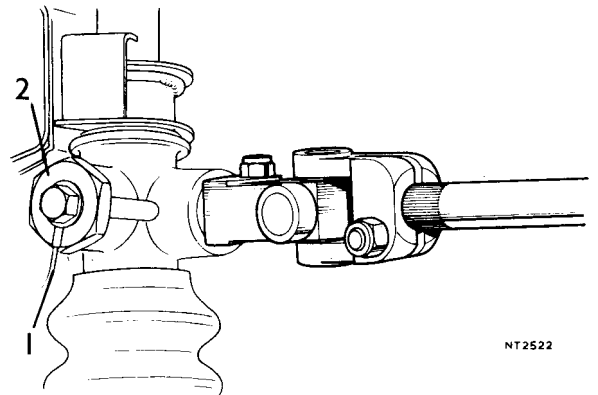

## STEERING COLUMN ASSEMBLY

– Remove and refit

57.40.01

### Removing

1. Disconnect the plug-in connectors for lights, horn, flashers, ignition and starter circuits.
2. Remove the steering wheel 57.60.01.
3. Remove the speedometer (LH Steer) or the tachometer (RH Steer). See 88.30.01 or 88.30.21 as appropriate.
4. Remove the pinchbolt securing the lower steering column to the flexible coupling.
5. Remove the two setscrews securing the steering column safety clamp and withdraw the clamp.
6. Remove the two bolts and nuts securing the forward end of the anti-torque strap to the scuttle.
7. Remove the domed protection covers from the steering column bracket bolts.
8. Remove the two bolts, nuts and washers securing the steering column bracket halves. Withdraw the harness cover.
9. Withdraw the anti-torque strap and the upper half of the column bracket.
10. Rotate the steering column to bring the shearbolts of the steering lock/ignition switch to an accessible position.
11. With a centre-punch mark the centre of the two shearbolts heads securing the steering lock/ignition bracket.

12. Using a small chisel, unscrew the shearbolts. If this proves unsuccessful drill the shearbolts and unscrew them using an 'Easiout' type extractor.
13. Remove the steering lock/ignition switch.
14. Withdraw the steering column.

*Continued*

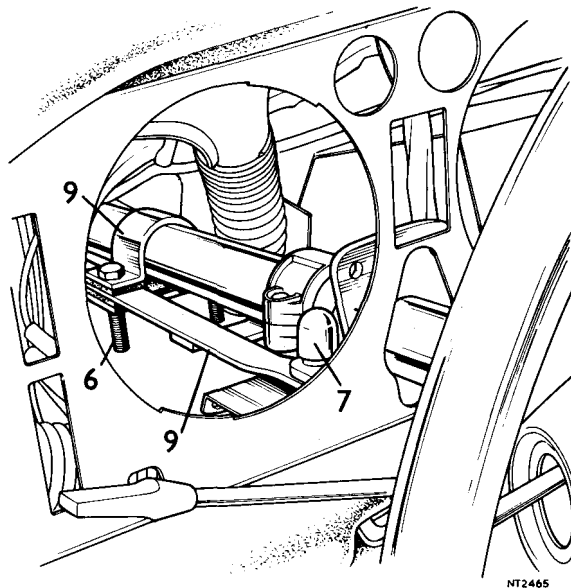

NT2465

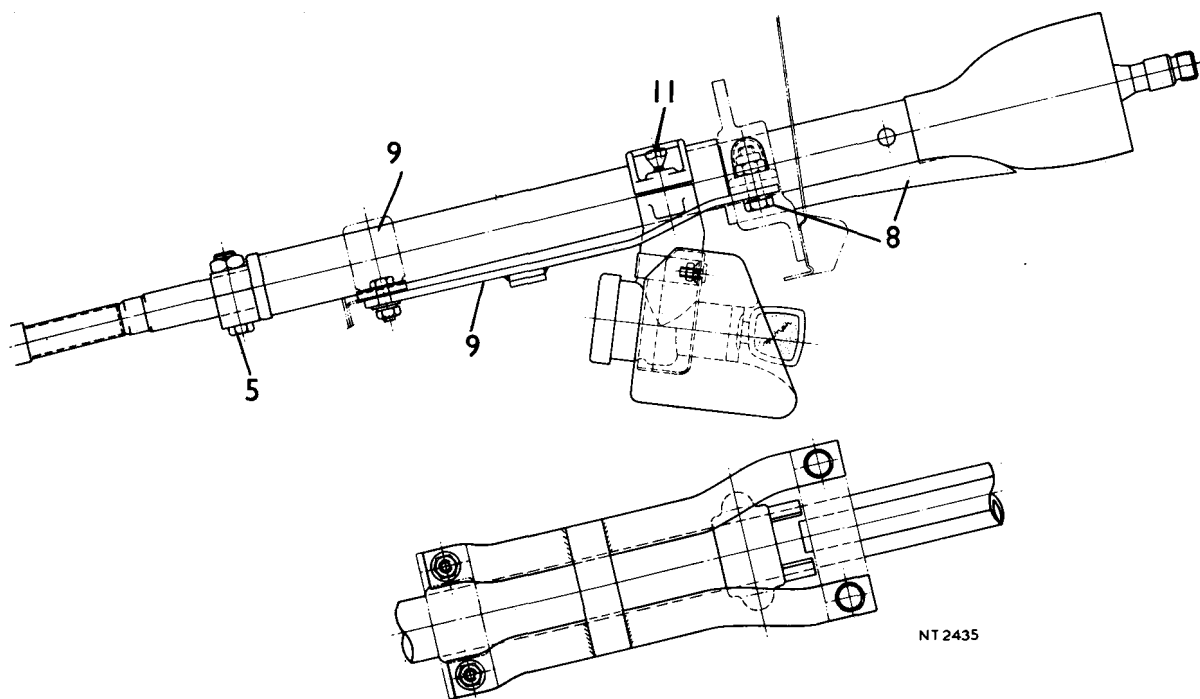

NT 2435

# STEERING

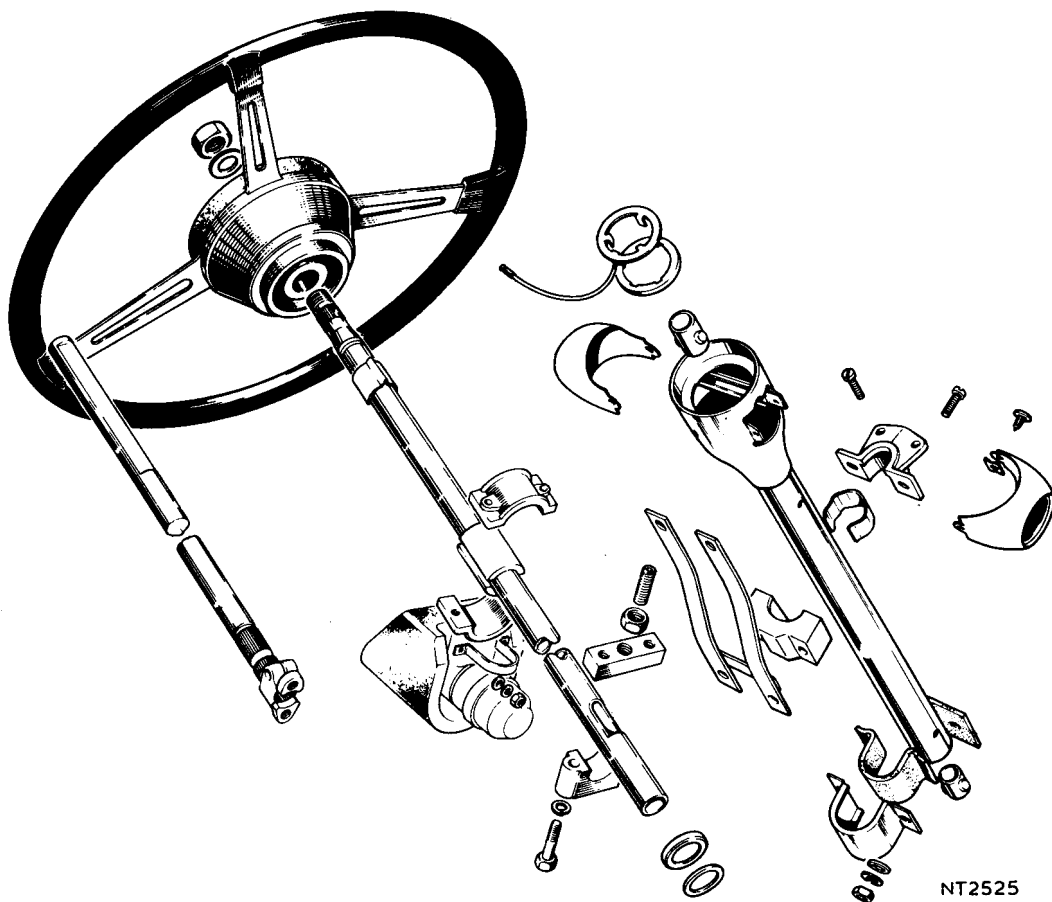

NT2525

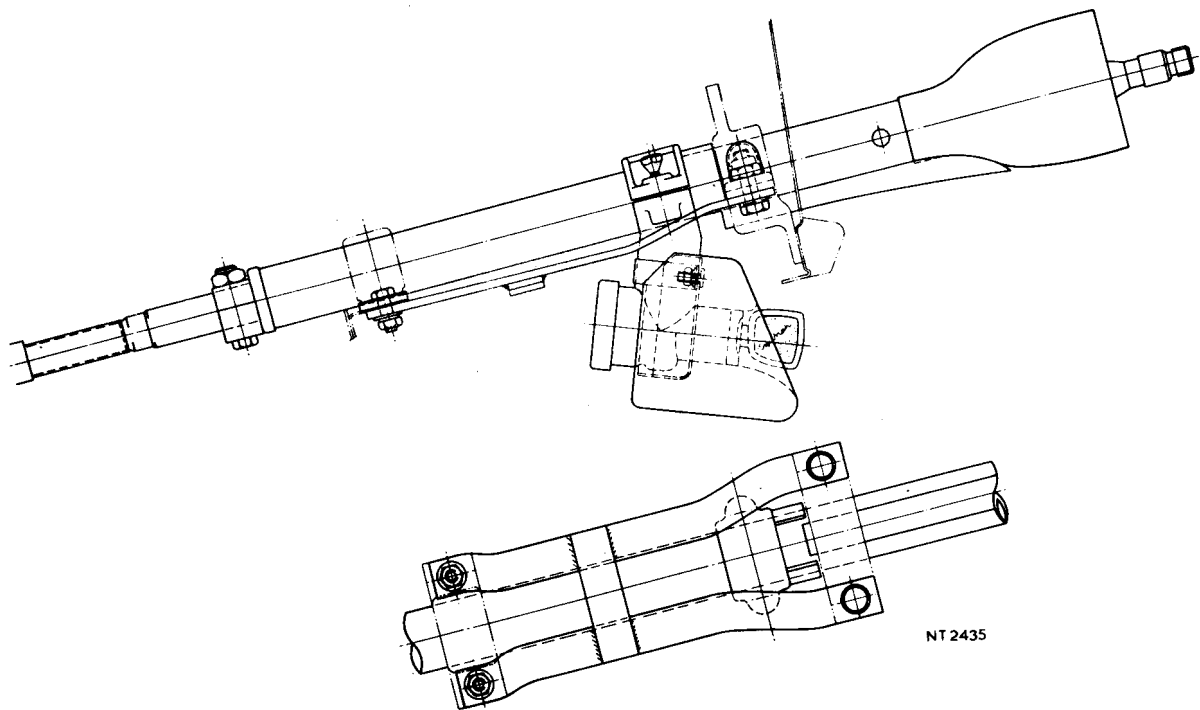

NT2435



## Refitting

15. Locate the steering column in position in the car.
16. Offer up the steering lock/ignition switch to the steering column. Ensure that the spacer ring is above the steering lock/ignition switch.
17. Fit the steering lock/ignition switch clamp and secure the two new shearbolts.
18. Evenly tighten the shearbolts until the heads shear.
19. Ensuring that the front road wheels are in 'straight ahead' position and the steering wheel is centralised, engage the lower steering mast in the flexible coupling. Check that the steel tubular spacer, bullet and plastic washer are fitted to the lower mast.
20. Fit the pinchbolt to the lower column and flexible coupling.
21. Fit the harness cover to the steering column.
22. Engage the anti-torque strap on the underside of the column upper bracket. Fit the felt strip to the lower half of the bracket.
23. Fit the spring clip and the upper half of the steering column bracket and secure with two bolts, plain washers and nuts. Note that the left hand bolt is entered from below the bracket; The right hand bolt is entered from above the bracket. Fit the domed protective covers over the two nuts.
24. Align the slot in the upper mast with the flat on the lower mast. Slide the plastic washer upwards until it is in contact with the steering column housing.
25. Fit the safety clamp between the bullet and the plastic washer and secure with two bolts.
26. Connect the wiring sockets for lights, flashers and starter/ignition etc.
27. Fit and tighten the two bolts, washers and nuts securing the front of the anti-torque strap to the scuttle.
28. Fit the speedometer and tachometer to the fascia. See 88.30.01 and 88.30.21.

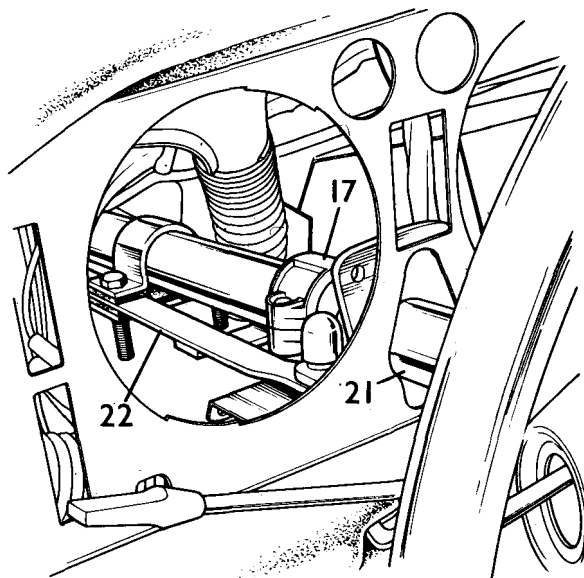

NT2465

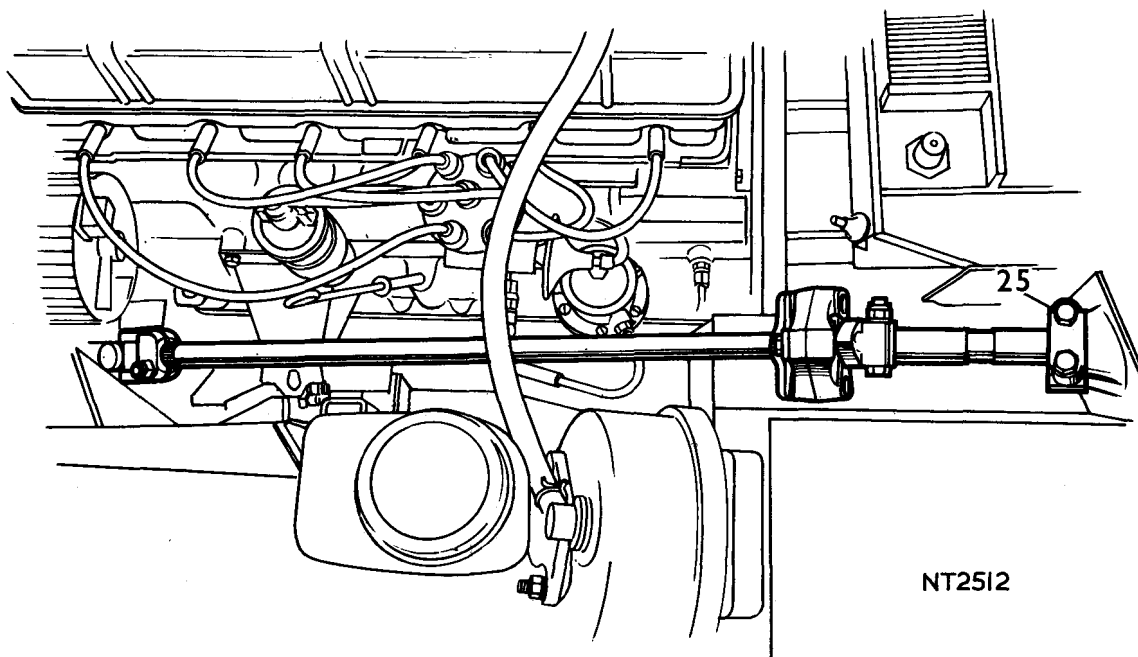

NT2512

# STEERING

## STEERING COLUMN – UPPER

– Remove and refit

57.40.02

### Removing

1. Remove the steering column assembly from the car 57.40.01.
2. Remove the steering wheel 57.60.01.
3. Remove the trafficator clip from the steering column.
4. Remove the tape securing the end cover at the lower end of the steering column housing and withdraw the end cover.
5. Slide the steering column downward until obstruction is felt.
6. Depress the dowls locating the steering column lower bush to release the bush from its location in the steering column housing.
7. Withdraw the steering column downward complete with the lower bush.
8. Remove the lower bush from the column.

### Refitting

9. Enter the steering column from the lower end of the housing.
10. Fit the lower bush to the column (rubber dots on end face of bush trailing) and align the dowls with the drillings in the steering column housing.
11. Press the bush into the housing ensuring that the dowels engage the holes in the column.
12. Fit the end cover and secure with tape.
13. Fit the trafficator clip.
14. Fit the steering column assembly to the car 57.40.01.
15. Fit the steering wheel 57.60.01.

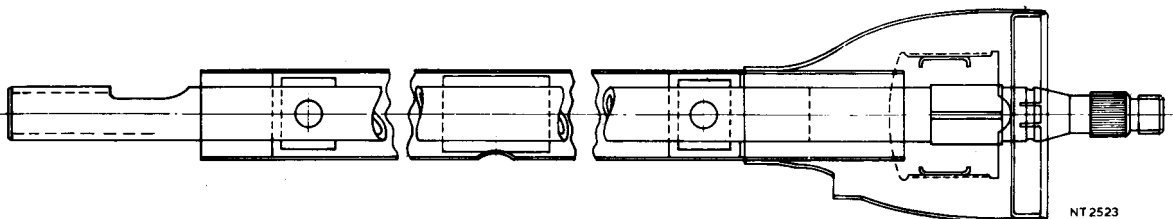
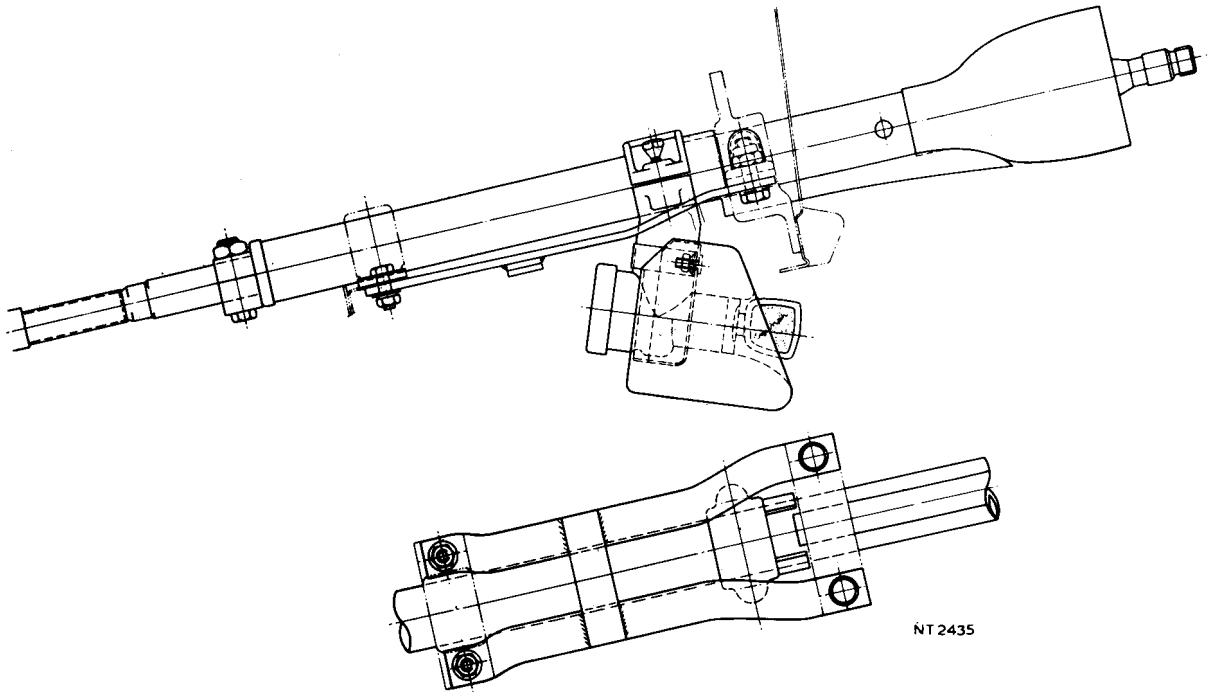

## STEERING COLUMN – LOWER

– Remove and refit

57.40.05

## Removing

1. Remove the pinchbolt and nut securing the lower end of the intermediate shaft to the universal joint.
2. Remove the pinchbolt securing the flexible coupling yoke to the lower steering column.
3. Slacken the locknut and grubscrew on the safety clamp. Remove the two bolts and spring washers from the safety clamp and withdraw the safety clamp.
4. Detach the intermediate shaft from the universal joint and withdraw the intermediate shaft complete with the flexible coupling.
5. Remove the tubular distance piece and bullet from the lower steering column.
6. Withdraw the lower steering column.

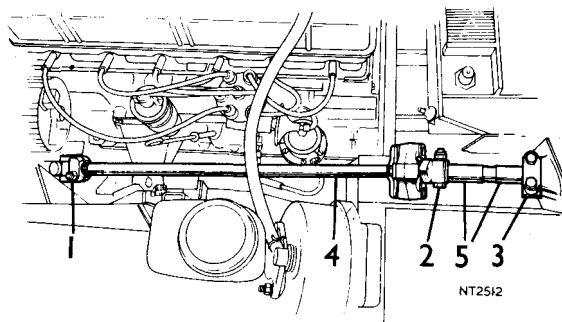

## Refitting

7. Enter the lower steering column in the upper steering column and align the machined flat on the lower column with the cutaway section of the upper column.
8. Place the safety clamp and securing bolts and spring washers in position but do not tighten the bolts. Ensure that the plastic washer is fitted between the upper face of the safety clamp and the bottom of the steering column housing.
9. Slide the bullet, tapered face trailing, and the tubular distance piece over the lower column.
10. Align the flat on the lower end of the intermediate shaft with the pinchbolt location in the universal joint and enter the intermediate shaft in the universal joint. Fit the pinchbolt and nut but do not tighten at this stage.
11. With the road wheels and the steering wheel in 'straight ahead' position, enter the yoke of the flexible coupling in the lower column and fit the pinchbolt washer and nut but do not tighten at this stage.
12. With light pressure on the steering wheel to prevent lift of the upper column slide the intermediate shaft upward to eliminate axial movement of the tubular distance piece and bullet.
13. Tighten both pinchbolt and the two bolts securing the safety clamp – torque 6 to 9 lbf ft (0.8 to 1.2 kgf m). Tighten the grubscrew – torque 18 to 20 lbf ft (2.5 to 2.8 kgf m). Tighten the locknut.

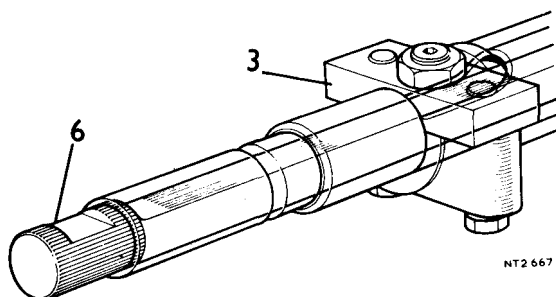

# STEERING

## STEERING COLUMN BUSHES

– Remove and refit

57.40.18

### Removing

1. Remove the upper steering column and the lower bush 57.40.02.
2. Remove the horn slip ring from the column housing.
3. Depress the locating dowls on the column housing upper bush and withdraw the upper bush.

### Refitting

4. Align the locating dowls on the upper bush with the drillings in the column housing.
5. Insert the upper bush from the top of the column housing ensuring that the dots formed on the end face of the bush are leading. Press the bush into the housing and engage the dowels in the housing drillings.
6. Fit the horn slip ring to the column housing.
7. Fit the steering column and the lower bush. 57.40.02.

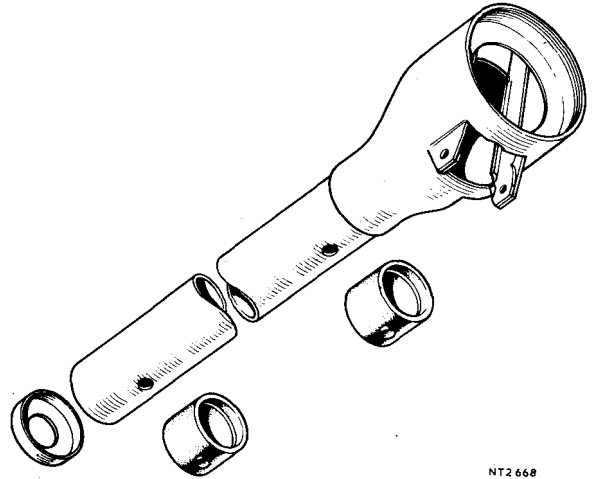

NT2 668

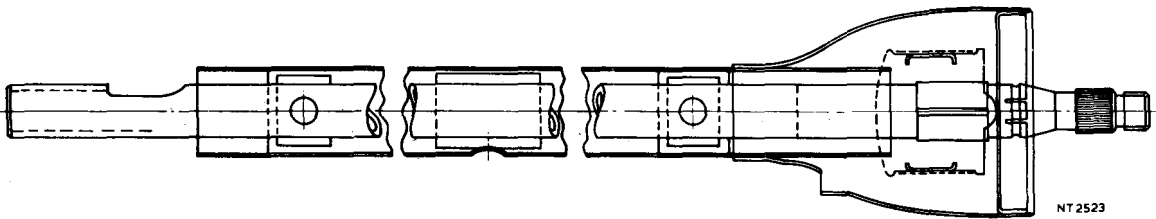

NT 2523

## STEERING COLUMN INTERMEDIATE SHAFT

– Remove and refit

57.40.22

## Refitting

## Removing

1. Set the road wheels to 'straight ahead' position.
  2. Scribe the lower end of the intermediate shaft and the universal joint to ensure original spline location on reassembly.
  3. Remove the pinch bolt and nut securing the universal joint to the intermediate shaft.
  4. Remove the locking wire from the two bolts securing the upper end of the intermediate shaft to the flexible coupling and remove the two bolts.
  5. Withdraw the intermediate shaft.
6. Align the previously marked scribe lines and engage the lower end of the intermediate shaft in the universal joint. If the shaft was removed with the spline location unmarked, or a new shaft is being fitted, set the road wheels and the steering wheel to 'straight ahead' positions and align the flat of the lower end of the shaft with the pinch bolt location in the universal joint. Check that the upper two hole flange aligns with the flexible coupling, adjust spline location as necessary.
  7. Fit the pinchbolt and nut to the universal joint. Do not tighten at this stage.
  8. Fit the two bolts to the flexible coupling ensuring that the tail of the bonding clip is secured. Tighten the two bolts and secure with locking wire.
  9. Tighten the universal pinchbolt.

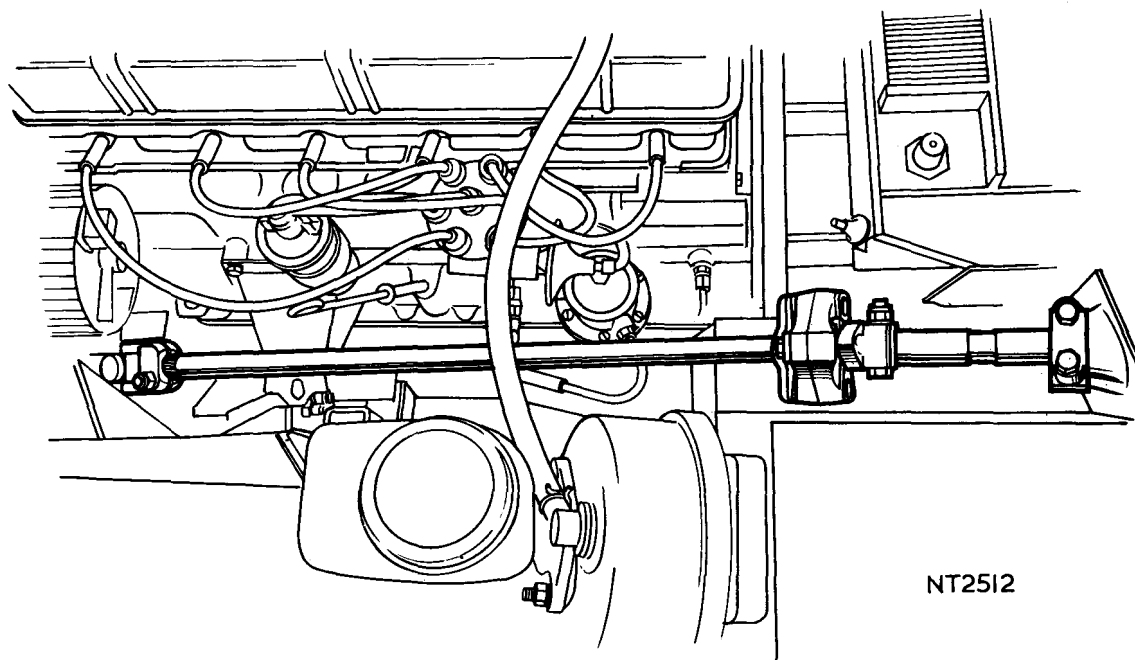

NT2512



## STEERING

### STEERING COLUMN UNIVERSAL JOINT/COUPLING – UPPER

– Remove and refit

57.40.26

#### Removing

1. Removing the lock wires securing the flexible coupling securing bolts.
2. Remove the securing bolts (4).
3. Withdraw the flexible coupling and bonding strap.

#### Refitting

4. Reverse instructions 1 to 3. Ensure that the bonding strap is refitted.

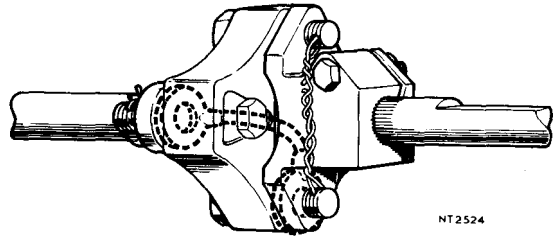

### STEERING COLUMN UNIVERSAL JOINT/COUPLING – LOWER

– Remove and refit

57.40.27

#### Removing

1. Remove the intermediate shaft 57.40.22.
2. Remove the pinchbolt securing the universal joint to the rack pinion shaft and withdraw the universal joint.

#### Refitting

3. Align the flat on the lower end of the intermediate shaft with the pinchbolt location in the yoke of the universal joint and fit the shaft to the universal joint.
4. With the road wheels and steering wheel in the 'straight ahead' positions, offer up the universal joint and intermediate shaft to the pinion shaft and check the upper flange of the intermediate shaft for alignment with the flexible coupling. Adjust as necessary on pinion shaft splines.
5. Fit the pinchbolt and nut to the pinion shaft and universal joint and tighten.
6. Fit the bolts and locking wire to the flexible coupling ensuring that the bonding strap is secured.
7. Fit and tighten the pinchbolt. Securing the intermediate shaft to the upper yoke of the universal joint.

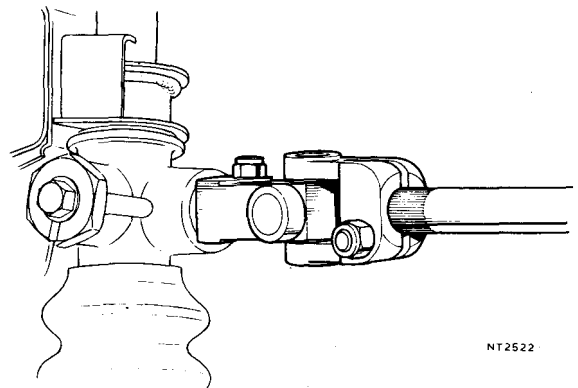

57.40.26  
57.40.27

**STEERING COLUMN LOCK/IGNITION/  
STARTER SWITCH**

– Remove and refit

57.40.31

**Removing**

1. Remove the speedometer and tachometer from the fascia.
2. Release the wiring harness socket from the steering lock.
3. Remove the domed protective cover from the steering column upper bracket nuts.
4. Remove the nuts, plain washers and bolts from the steering column upper bracket.
5. Remove the top half of the steering column upper bracket.
6. Remove the nuts, spring washers and bolts securing the anti-torque strap to the scuttle.
7. Remove the cable harness cover from the underside of the steering column.
8. Withdraw the anti-torque strap from the steering lock.
9. Rotate the steering column 180° to expose the sheared heads of the two bolts securing the steering lock to the steering column.
10. Using a centre-punch mark the centre of the two shear bolt heads.
11. Using a small chisel unscrew the shear bolts. If this method proves unsuccessful drill the shearbolts and unscrew them with an 'Easiout' type extractor.
12. Remove the steering lock.

**Refitting**

13. Offer up the steering lock and clamp bracket to the steering column.
14. Fit two new shearbolts. Evenly tighten the shearbolts until the heads shear.
15. Reverse instruction 1 to 9.

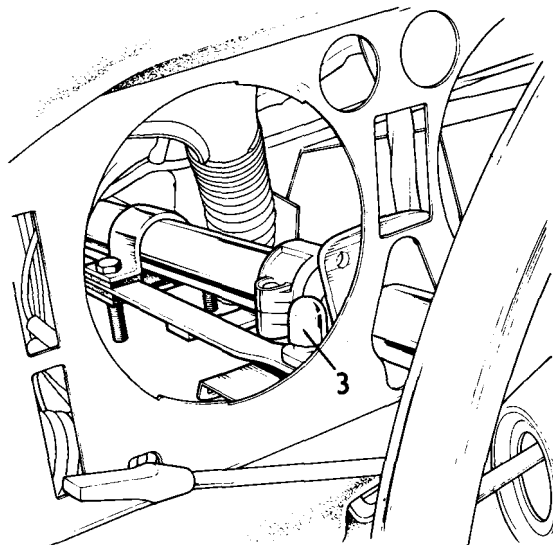

NT2465

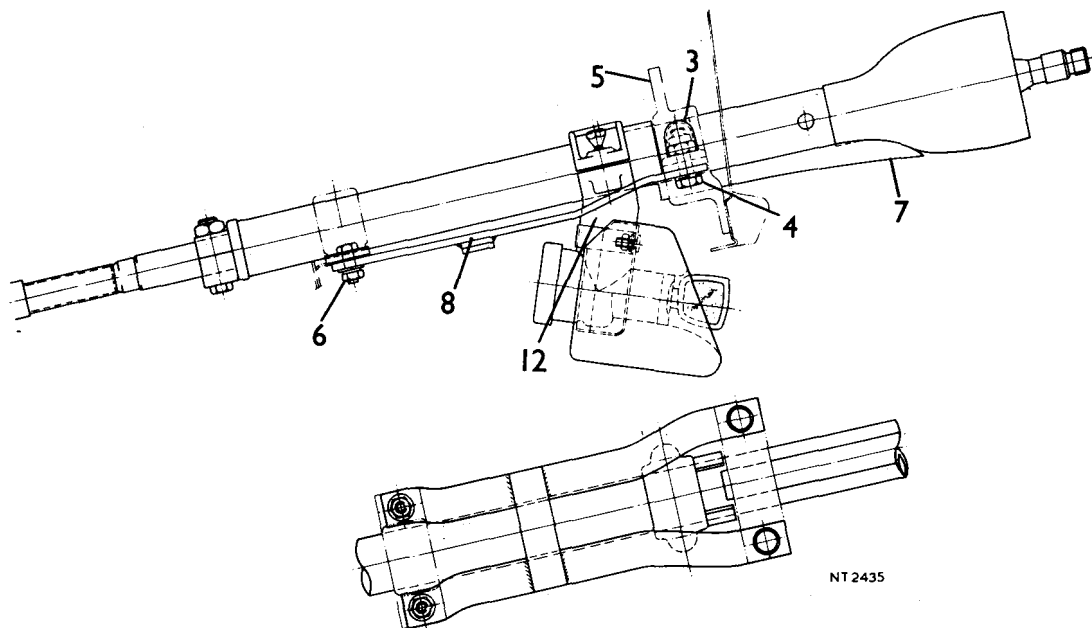

NT 2435

## STEERING

### TIE ROD BALL JOINT – OUTER

– Remove and refit 57.55.02

#### Removing

1. Remove the road wheel.
2. Slacken the locknut securing the outer ball joint.
3. Remove the nut and washer securing the ball joint to the steering arm.
4. Release the ball joint from the steering arm.
5. Unscrew the ball joint assembly from the tie rod.

#### Refitting

6. Reverse instructions 1 to 5.
7. Check and adjust front wheel track as necessary.

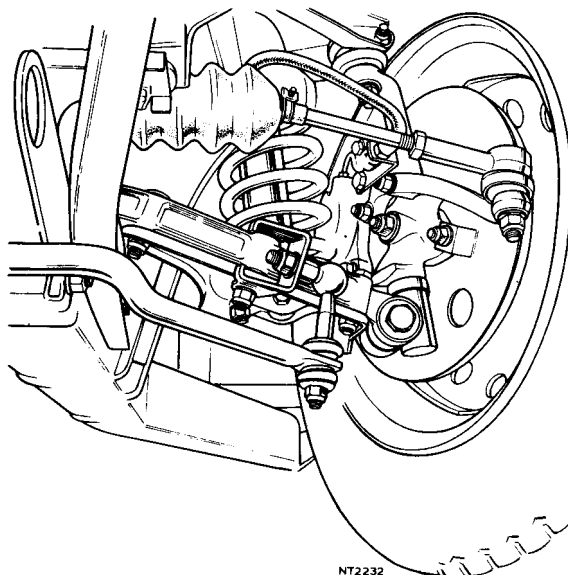

### TIE ROD BALL JOINT – INNER

– Remove and refit 57.55.03

#### Removing

1. Remove the rack from the car 57.25.01.
2. Remove the tie rod outer ball joint and locknut.
3. Release the gaiter clips and remove the gaiter.
4. Wipe the grease from the inner ball joint and slacken the rack shaft locknut securing the rack shaft to the ball joint adaptor. To prevent stress being applied to the pinion, the opposite adaptor should be held with a spanner.
5. Unscrew the tie rod assembly from the rack shaft.
6. Straighten the lock tabs securing the tie rod ball housing/adaptor.
7. Unscrew the adaptor and withdraw spring, shims, ball seat and tie rod from the housing.

#### Refitting

8. Lubricate the ball housing and insert the tie rod.
9. Fit the ball seat, shim(s) new tab washer and adaptor.
10. Tighten the adaptor, torque 80 lbf ft (11.1 kgf m), and check the tie rod for end-float and articulation. End-float should be within 0.0005 to 0.003 in (0.013 to 0.076 mm). There must be no tight spots in articulation. Adjust by adding or removing shims as required.
11. Bend over the lock washer tabs.
12. Enter the spring in the ball housing and fit the tie rod assembly to the rack shaft.
13. Tighten the adaptor and the rack shaft locknut to a torque of 80 lbf ft (11.1 kgf m), ensuring that the pinion is not subjected to stress.
14. Smear the ball joint with grease and fit the gaiter and clips.
15. Fit the tie rod outer locknut and ball joint.
16. Fit the rack to the car 57.55.03.
17. Check and adjust front wheel track as required.

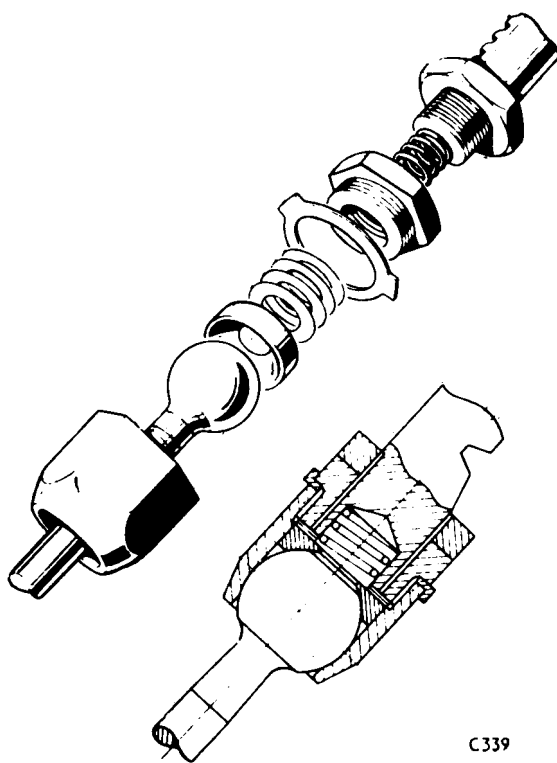

**STEERING WHEEL**

– Remove and refit 57.60.01

Service tool S.3600

**Removing**

1. Remove the steering wheel pad.
2. Prise out the horn push.
3. Withdraw the horn connection brush.
4. Remove the nut and plain washer securing the steering wheel to the steering mast.
5. Scribe the top of the steering mast and the hub of the steering wheel to ensure spline re-engagement in original location.
6. Using Tool S3600, remove the steering wheel.

**Refitting**

7. Reverse instructions 1 to 6.  
When replacing the horn connection brush ensure that the spring end is entered in the wheel hub. If the wheel was withdrawn without spline location marks, set the road wheels to 'straight ahead' and fit the steering wheel with the top spokes horizontal.

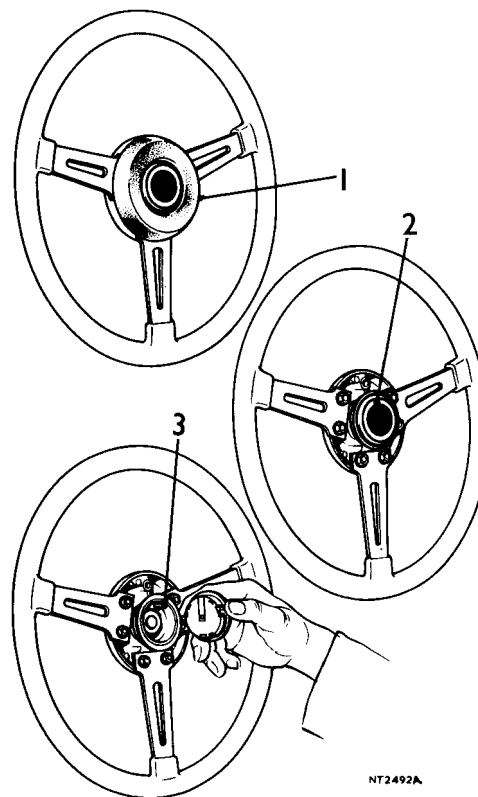

NT2492A

**STEERING WHEEL HUB**

– Remove and refit 57.60.02

**Removing**

1. Remove the steering wheel and hub from the car 57.60.01.
2. Remove the six bolts and plain washers securing the steering wheel spokes to the hub.

**Refitting**

3. Reverse instructions 1 and 2.

# STEERING

## STEERING GEOMETRY

57.65.00

Only two adjustments are possible: Front wheel alignment and Camber angle.

DATA	Kerb condition	Laden condition (2 up)
Camber – Carburetter . . . . .	$\frac{1}{4}^{\circ}$ pos $\pm 1^{\circ}$	$\frac{1}{4}^{\circ}$ Neg $\pm \frac{1}{2}^{\circ}$
–Petrol injection . . . . .	$\frac{1}{2}^{\circ}$ pos $\pm 1^{\circ}$	$0^{\circ} \pm \frac{1}{2}^{\circ}$
Castor . . . . .	$2\cdot3/4^{\circ} \pm 1^{\circ}$	$2\cdot3/4^{\circ} \pm \frac{1}{2}^{\circ}$
King pin inclination – <i>Carburetter</i> . . . . .	$8\cdot3/4^{\circ} \pm 1^{\circ}$	$9\cdot1/4^{\circ} \pm \frac{3}{4}^{\circ}$
– Petrol injection . . . . .	$8\cdot1/2^{\circ} \pm 1^{\circ}$	$9^{\circ} \pm \frac{3}{4}^{\circ}$
Toe in . . . . .	1/16 – 1/8 in (1·6 – 3·2 mm)	1/16 – 1/8 in (1·6 – 3·2 mm)

## FRONT WHEEL ALIGNMENT

– Check and adjust 57.65.01

### Checking

1. Locate the car on level ground with the front wheels in 'straight ahead' position.
2. Using wheel alignment equipment check the front wheels for toe-in. Front wheel toe-in should be within 1/16 to 1/8 in (1·6 to 3·2 mm).

### Adjusting

3. Slacken the outer clips on the rack gaiters.
4. Slacken the locknuts at the tie rod outer ends.
5. Shorten or extend both tie rods equally to obtain the required toe-in of 1/16 to 1/8 in (1·6 to 3·2 mm).
6. Tighten the locknuts at the tie rod outer ends.
7. Tighten the gaiter clips.

**NOTE:** Tie rods should be adjusted equally. Differences in tie rod lengths will result in incorrect wheel angles on turns.

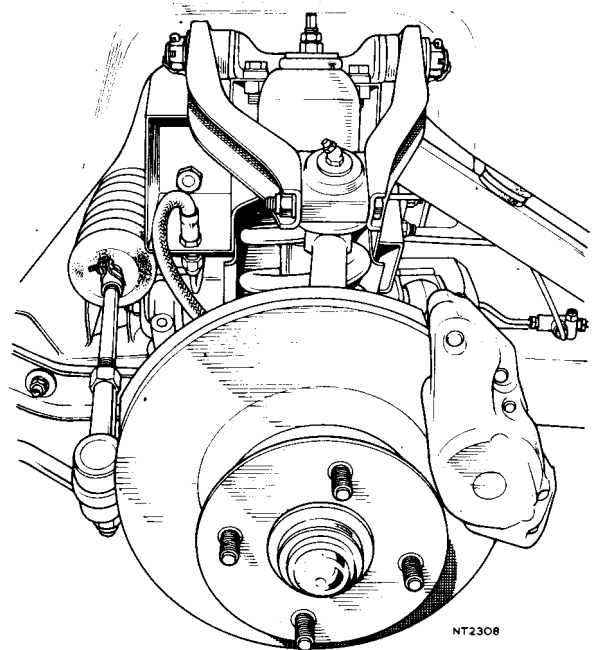

**CAMBER ANGLE**

– Check and adjust

57.65.05

**Checking**

1. Using suitable equipment check the front wheels for camber angle. Front wheel camber should be within the following limits:

Carburetter model  $\frac{1}{4}^{\circ}$  pos  $\pm 1^{\circ}$  (kerb)  $\frac{1}{4}^{\circ}$  neg  $\pm \frac{1}{2}^{\circ}$  (laden – 2 up)

P. I. Model  $\frac{1}{2}^{\circ}$  pos  $\pm 1^{\circ}$  (kerb)  $0^{\circ} \pm \frac{1}{2}^{\circ}$  (laden – 2 up).

Before altering camber angles, ensure that the cause is not attributable to wear in the ball joints, trunnions, wishbone bushes, or worn road springs.

**Adjusting**

2. Jack up the car and support the chassis on stands.
3. Slacken the four nuts securing the lower wishbone brackets to the chassis.
4. Remove or add shim(s) equally to both wishbone brackets as required. Add shim(s) to go negative: remove shim(s) to go positive. Repeat as necessary on opposite lower wishbone.
5. Tighten the nuts securing the wishbone brackets.
6. Remove the chassis stands.
7. Check and adjust front wheel track as necessary.

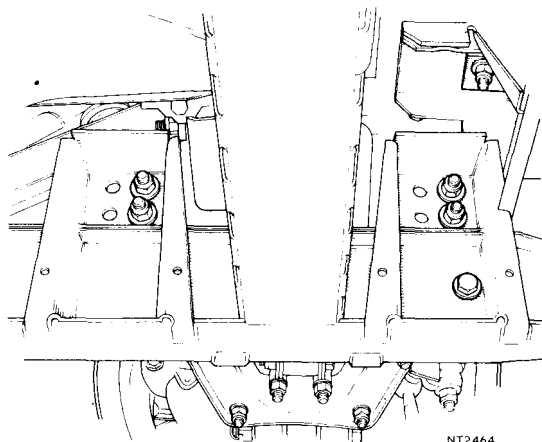

NT2464

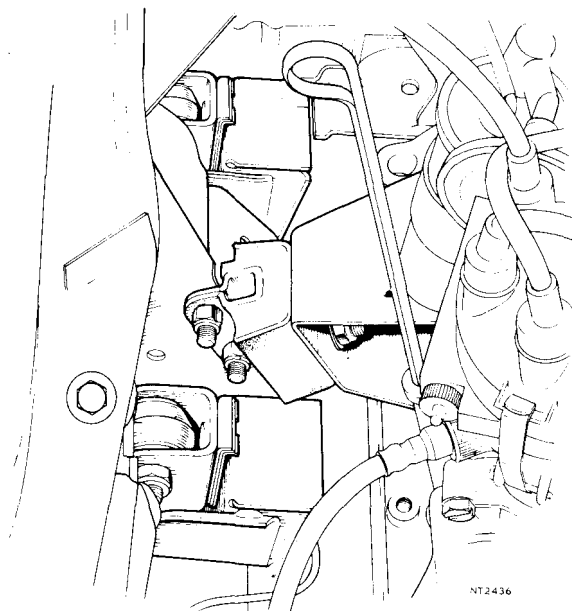

NT2436

**FRONT SUSPENSION OPERATIONS**

<b>Anti-roll bar</b>	
– remove and refit	60.10.01
– link – remove and refit	60.10.02
– rubbers – remove and refit	60.10.04
<b>Ball joint – remove and refit</b>	60.15.02
<b>Front damper</b>	
– remove and refit	60.30.02
– bushes – remove and refit	60.30.07
<b>Front hub</b>	
– overhaul	60.25.07
– remove and refit	60.25.01
– bearing end-float – check and adjust	60.25.13
– bearings – remove and refit	60.25.14
– oil seal – remove and refit	60.25.15
– stub axle – remove and refit	60.25.22
– wheel studs – remove and refit	60.25.29
<b>Front road spring – remove and refit</b>	60.20.01
<b>Lower wishbone</b>	
– overhaul	60.35.09
– remove and refit	60.35.02
<b>Trunnion</b>	
– overhaul	60.15.13
– remove and refit	60.15.03
<b>Upper wishbone</b>	
– overhaul	60.35.08
– remove and refit	60.35.01
<b>Vertical link – remove and refit</b>	60.25.23



ANTI-ROLL BAR

– Remove and refit

60.10.01

Removing

1. Remove the nyloc nut and plain washer securing the anti-roll bar link to the lower wishbone bracket and detach the link from the bracket. Repeat on opposite side of car.
2. Remove the four nuts and plain washers securing the two 'U' bolts to the front crossmember.
3. Withdraw the 'U' bolts and brackets.
4. Withdraw the anti-roll bar.
5. Remove the nuts securing the lower end of the anti-roll bar links to the anti-roll bar. Detach the link and the rubber mountings, washers and distance tubes.
6. Remove the anti-roll bar mounting bushes.

Refitting

7. Reverse instructions 1 to 6. Ensure that the anti-roll bar is fitted centrally on the front crossmember.

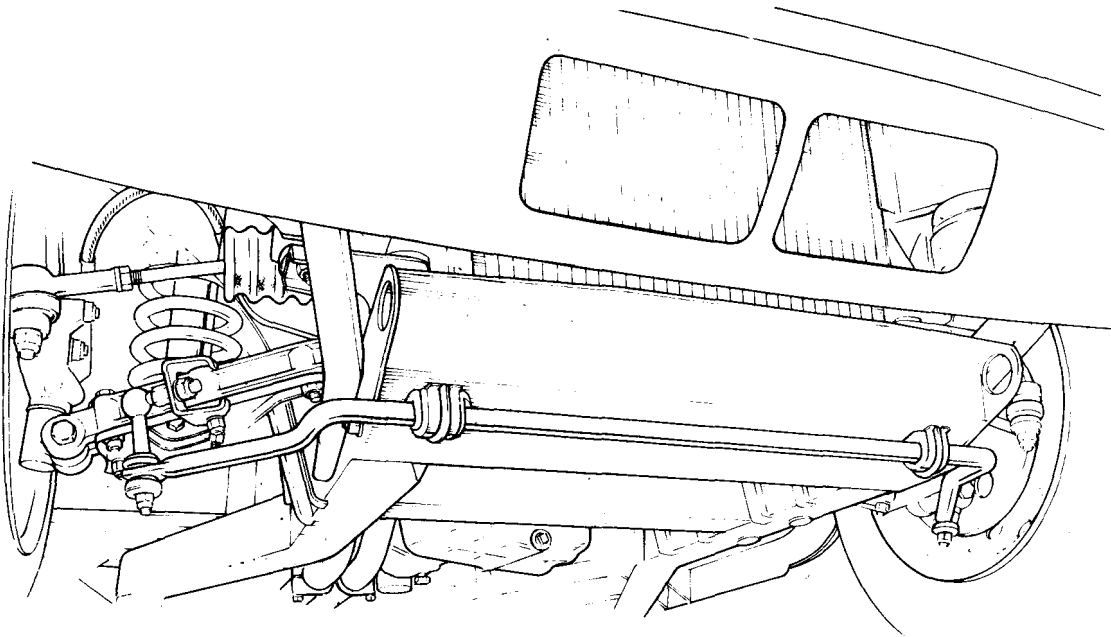
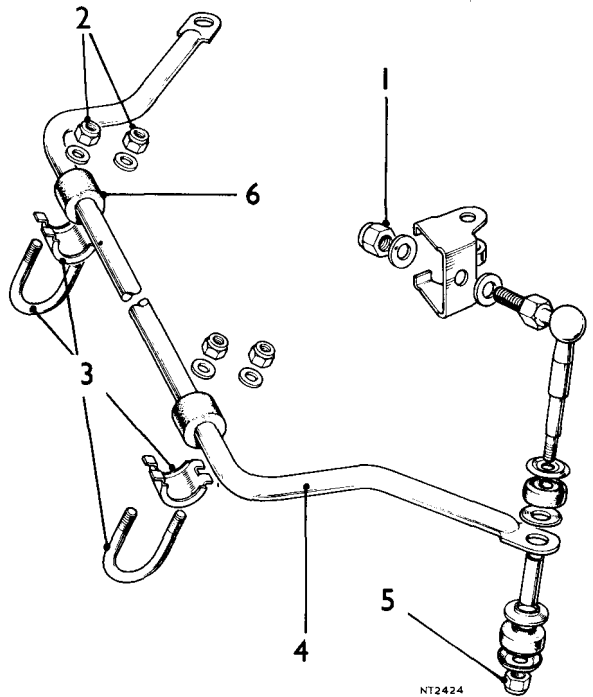



# FRONT SUSPENSION

## ANTI-ROLL BAR LINK

– Remove and refit

60.10.02

### Removing

1. Remove the nyloc nut and plain washer securing the anti-roll bar link to the lower wishbone bracket and detach the link from the bracket.
2. Remove the nyloc nut securing the lower end of the anti-roll bar link to the anti-roll bar and withdraw the anti-roll bar link, washers, rubbers and distance tube.

### Refitting

3. Reverse instructions 1 and 2.

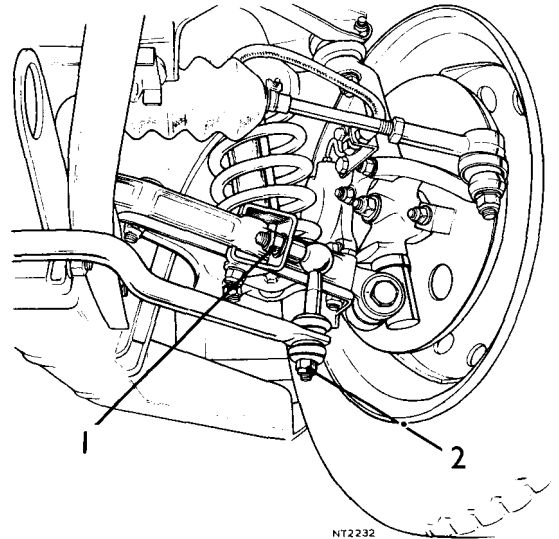

## ANTI-ROLL BAR RUBBERS

– Remove and refit

60.10.04

### Removing

1. Remove the four nyloc nuts and plain washers securing the two 'U' bolts to the front crossmember.
2. Withdraw the 'U' bolts and mounting brackets.
3. Remove the mounting rubbers.

### Refitting

4. Reverse instructions 1 to 3.

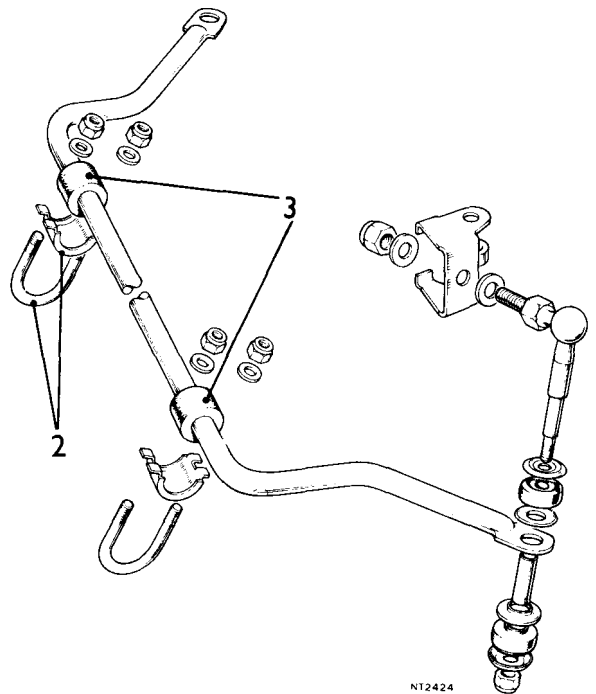

**BALL JOINT**

– Remove and refit

60.15.02

Service tool S166

**Removing**

1. Jack up the car and support the chassis on stand(s).
2. Remove the front road wheel.
3. Locate a jack under the road spring pad on the lower wishbone and raise the jack sufficient to relieve the upper ball joint of spring tension.
4. Remove the nyloc nut and plain washer securing the ball joint to the vertical link.
5. Using Tool S166 release the ball joint from the vertical link.
6. Remove the two bolts, plain washers and nyloc nuts securing the ball joint housing to the upper wishbone. Note that the outer bolt is entered from the rear side of the wishbone and that the inner bolt is entered from the forward side of the wishbone.
7. Remove the ball joint and housing from the upper wishbone.

**Refitting**

8. Reverse instructions 1 to 4 and 6 to 7. Tightening torque for the bolts securing the ball joint housing to the upper wishbone is 24 to 32 lbf ft (3.3 to 4.4 kgf m.). Tightening torque for the nut securing the ball joint to the vertical link is 35 to 50 lbf f (4.8 to 6.9 kgf m.).

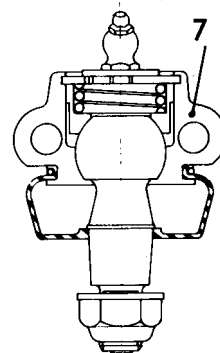
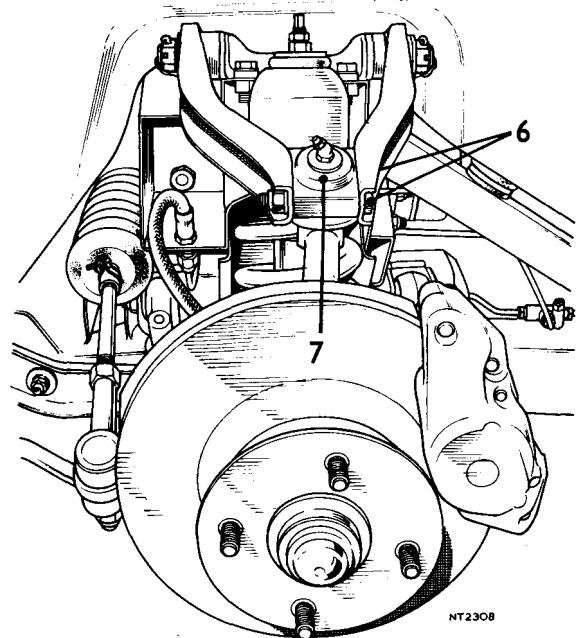
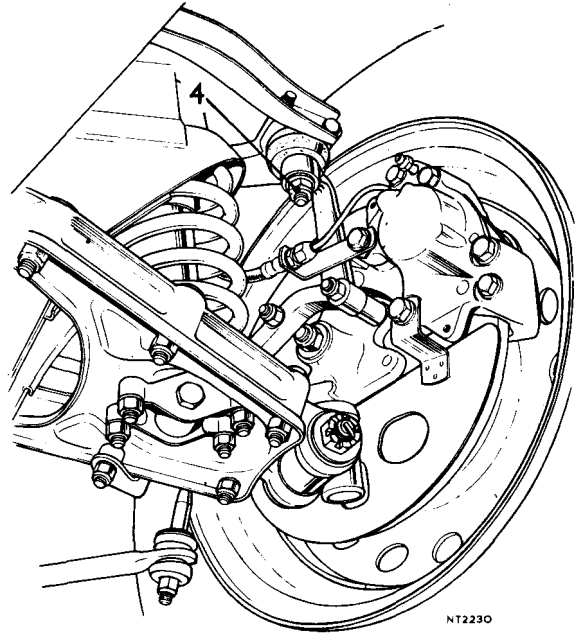

## TRUNNION

– Remove and refit

60.15.03

### Removing

1. Jack up the car and support the chassis.
2. Remove the road wheel.
3. Remove the front hub 60.25.01/02.
4. Remove the disc shield. 70.10.18.
5. Locate a jack under the road spring pad on the lower wishbone and raise the jack sufficient to relieve the upper ball joint and trunnion of spring tension.
6. Remove the split pin from the slotted nut securing the trunnion to the lower wishbone.
7. Remove the slotted nut and bolt securing the trunnion to the lower wishbone.
8. Withdraw the trunnion washers and the vertical link from the lower wishbone.
9. Unscrew the trunnion from the vertical link. (Right hand vertical link – right hand thread: Left hand vertical link – left hand thread.)

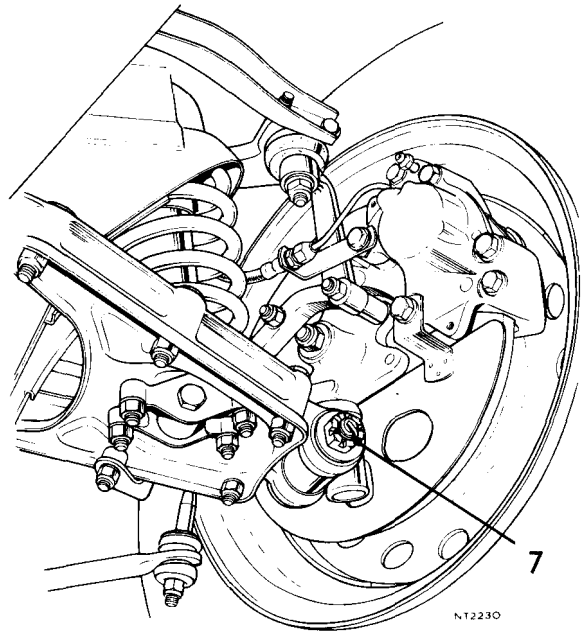

### Refitting

10. Using a 90 S.A.E. EP lubricant partially fill (25%) the trunnion. Fit the rubber boot and screw the trunnion into position on the vertical link. (Right hand vertical link – right hand thread: Left hand vertical link – left hand thread).
11. Fit the vertical link washers and trunnion to the lower wishbone.
12. Reverse instructions 1 to 7. The slotted nut should be tightened to a torque of 50 to 65 lbf ft (4.8 to 9 kgf m).

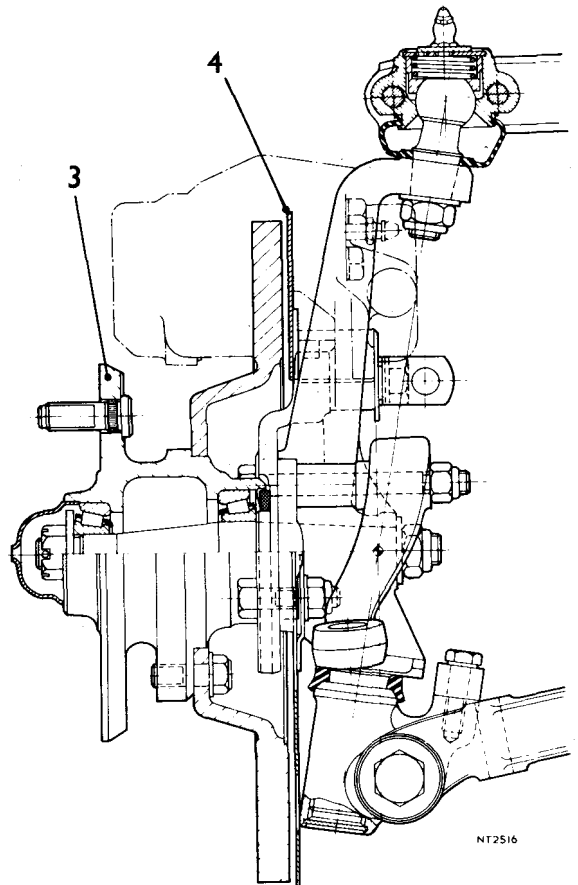

## TRUNNION

– Overhaul

60.15.13

1. Remove the trunnion from the car 60.15.03.

### Dismantling

2. Remove the thrust washers.
3. Remove the nylon bushes and backing washers.

### Assembling

4. Reverse instructions 2 to 3 using new components.
5. Fit the trunnion to the car 60.15.03.

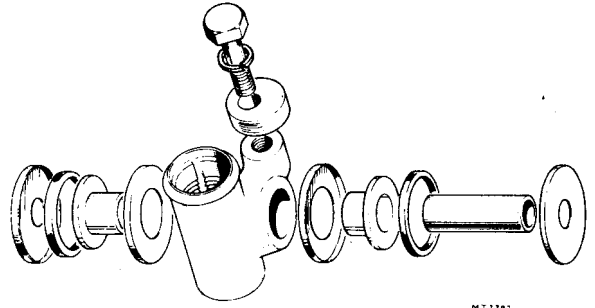

## FRONT ROAD SPRING

– Remove and refit

60.20.01

### Removing

1. Jack up the car and support the chassis on stand(s).
2. Remove the front wheel.
3. Remove the front damper 60.30.02.
4. Disconnect the anti-roll bar link from the anti-roll bar.
5. Position a jack under the lower wishbone spring plate ensuring that the jack pad will not damage the damper mounting studs. Ensure also that the pad does not obstruct the spring plate securing bolts. The jack pad must be placed directly under the spring lower seat.
6. Raise the jack to partially compress the road spring and to relieve the vertical link joints of spring tension.
7. Remove the split pin, slotted nut, washers and bolt securing the trunnion to the lower end of the vertical link.
8. Release the vertical link and trunnion from the outer ends of the lower wishbone.
9. Remove the nut, washer and bolt securing the anti-roll bar link bracket to the lower wishbone.
10. Withdraw the anti-roll bar link bracket and spacer from the wishbone.
11. Remove the five nuts, washers and three bolts securing the spring plate to the lower wishbone.
12. Separate the lower wishbone arms from the spring plate.
13. Carefully lower the jack taking care that the spring plate does not foul on the chassis. Continue lowering the jack until the road spring is relieved of tension.
14. Withdraw the spring plate and the road spring complete with upper and lower insulating rings.

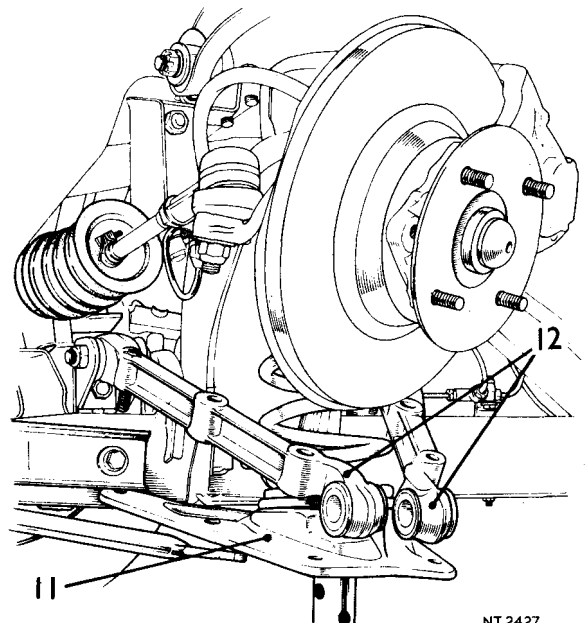
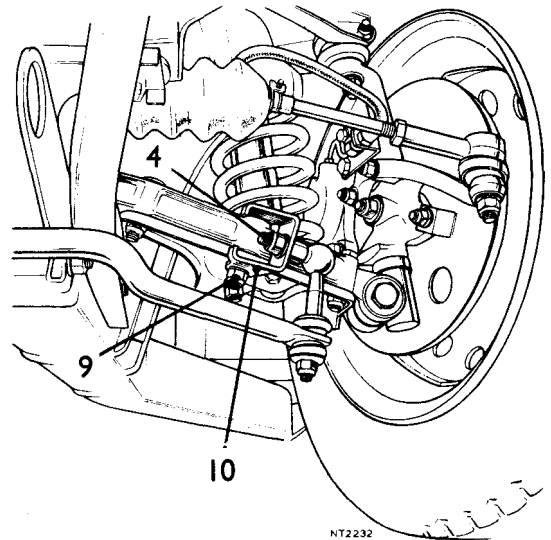

*Continued*

## FRONT SUSPENSION

### Refitting

15. Fit the insulating rings to the road spring: thin ring to top; thick ring to bottom.
16. Engage the top of the spring in the spring turret.
17. Engage the spring pan in the lower end of the spring.
18. Position the jack on the spring plate directly under the spring. Ensure that the jack pad will neither slip nor cause damage to the damper studs.
19. Carefully raise the jack and compress the road spring.
20. Align the spring plate with its location on the lower wishbone arms and enter the studs and five securing bolts. The bolt securing the anti-roll bar link bracket should be omitted at this stage.
21. Fit the five plain washers and nuts and evenly draw the spring plate into position on the wishbone arms.
22. Fit the anti-roll bar link bracket, spacer and securing bolt, plain washer and nut. Tighten the bolt and nut.
23. Tighten the other five nuts.
24. Engage and align the trunnion in the lower wishbone ensuring that the trunnion thrust washers are not omitted.
25. Fit the trunnion bolt, washers and slotted nut.
26. Tighten the slotted nut and secure with a new split pin.
27. Remove the jack from under the lower wishbone.
28. Fit the front damper 60.30.02.
29. Fit the anti-roll bar link.
30. Fit the front wheel and remove the stand(s) from the chassis.

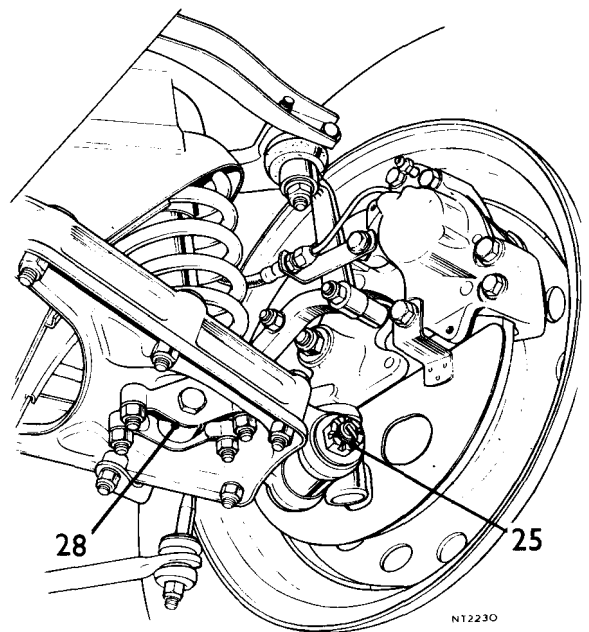
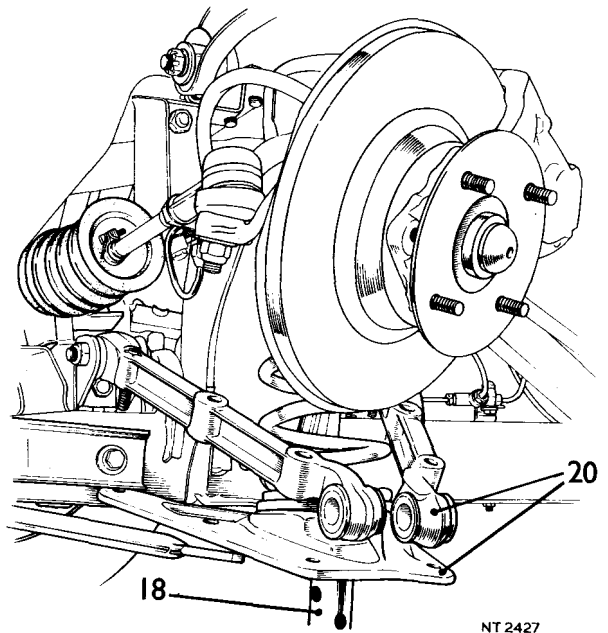

## FRONT HUB

– Remove and refit

60.25.01

## Removing

1. Jack up the car and remove the front wheel.
2. *Wire wheels only.* Remove the four nuts securing the hub extension to the hub. Withdraw the hub extension.  
Remove the two bolts and spring washers securing the caliper to the vertical link and ease the caliper clear of the disc. Support the caliper using string or wire. Ensure that strain is not imposed on the flexible brake hose.
4. Remove the hub cap.
5. Remove the split pin, slotted nut and washer securing the hub to the stub shaft.
6. Withdraw the hub complete with bearings, inner hub seal and disc.

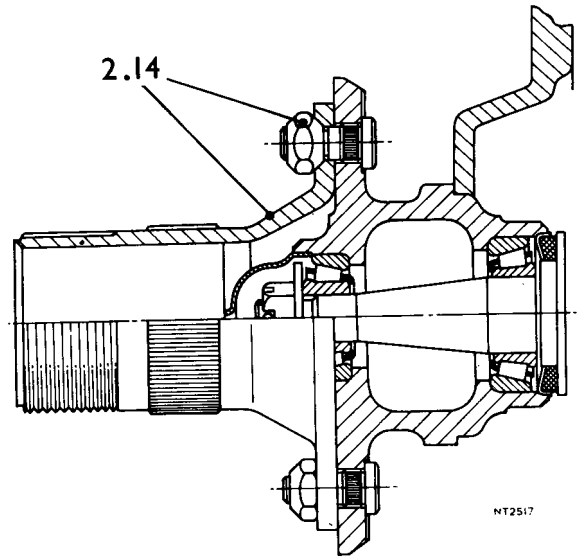

## Refitting

7. Partially pack the hub with clean grease.
8. Ensure that the hub seal is installed on the inner side of the hub and fit the hub and bearings to the stub shaft.
9. Fit the washer and slotted nut to the stub shaft.
10. Tighten the slotted nut to 5 lbf ft (0.7 kgf m) and slacken the nut one flat to allow insertion of a new split pin. The required end-float is 0.003 to 0.005 ins (0.08 to 0.13 mm).
11. Fit the split pin.
12. Half fill the hub cap with clean grease and fit the cap to the hub.
13. Remove the string or wire supporting the caliper and fit the caliper. Note that the caliper upper bolt also secures the disc shield and the flexible hose support bracket.
14. *Wire wheels only.* Fit the hub extension.
15. Fit the road wheel and remove the jack.

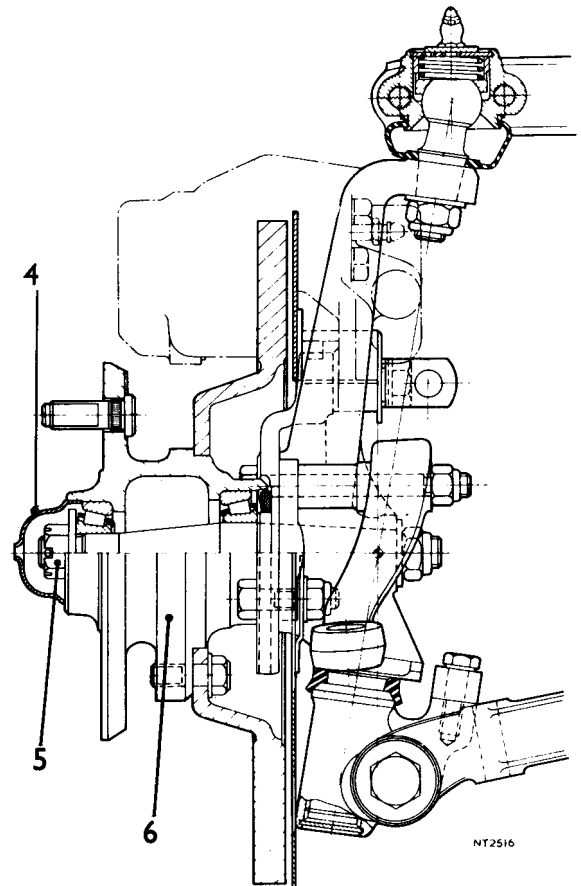

## FRONT SUSPENSION

### FRONT HUB

– Overhaul

60.25.07

#### Dismantling

1. Remove the front hub 60.25.01/02.
2. Withdraw the outer bearing.
3. Withdraw the inner oil seal, inner bearing shield and inner bearing.
4. Extract the inner and outer bearing tracks.
5. Thoroughly clean all components.

#### Reassembling

6. Examine all components and renew as necessary.
7. Fit the bearing inner and outer tracks to the hub.
8. Insert the inner bearing.
9. Fit the inner bearing shield (lip of shield outward).
10. Partially fill the hub with clean grease.
11. Lubricate the new felt seal and install the seal in the inner side of the hub.
12. Insert the outer bearing.
13. Fit the hub to the car 60.25.01/02.

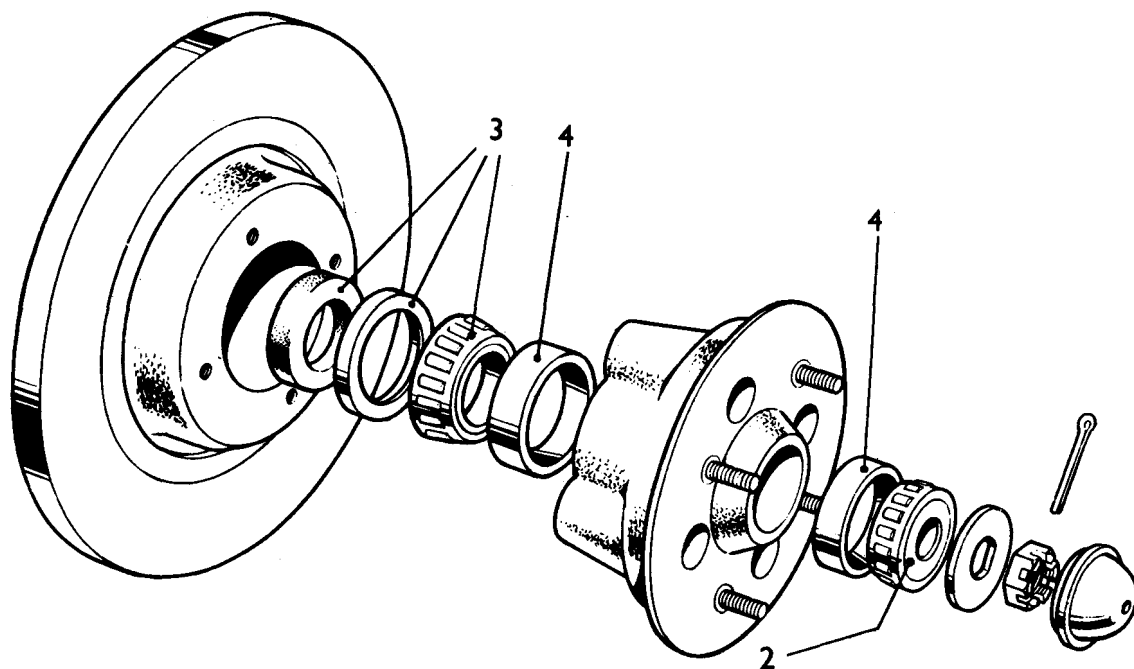

NT2 671

**FRONT HUB BEARING END-FLOAT**

– Check and adjust 60.25.13

**Checking**

1. Jack up the car and remove the front wheel.
2. Remove the disc brake pads.
3. Check the front hub for bearing end-float. End-float should be within 0.003 to 0.005 in (0.08 to 0.13 mm).

**Adjusting**

4. *Wire wheels only.* Remove the hub extension.
5. Remove the hub cap.
6. Remove the split pin from the slotted nut.
7. Tighten or slacken the slotted nut as necessary to obtain 0.003 to 0.005 in (0.08 to 0.13 mm) bearing end-float.
8. Secure the slotted nut with a new split pin.
9. Clean the hub cap and partially fill it with fresh grease.
10. Fit the hub cap.
11. *Wire wheels only.* Fit the hub extension.
12. Fit the brake pads.
13. Fit the road wheel and remove the jack.

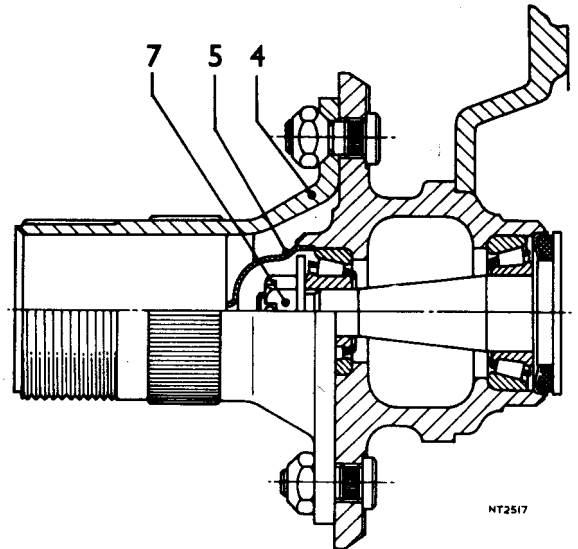

**FRONT HUB BEARINGS**

– Remove and refit 60.25.14

As operation 60.25.07/08.

**FRONT HUB OIL SEAL**

– Remove and refit 60.25.15

**Removing**

1. Remove the front hub 60.25.01/02.
2. Withdraw the oil seal.

**Refitting**

3. Partially pack the hub with clean grease.
4. Lubricate the new hub seal and enter the seal in the hub.
5. Fit the hub to the stub axle 60.25.01/02.

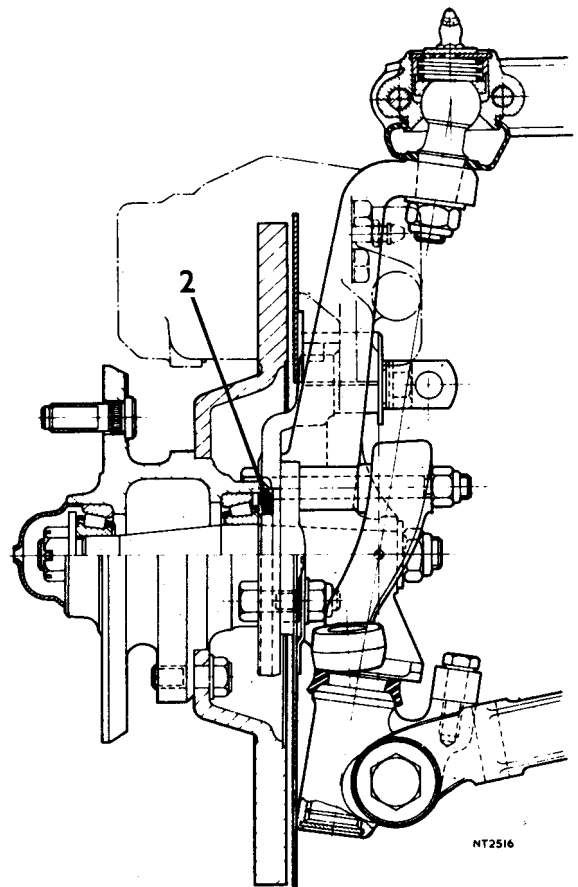



# FRONT SUSPENSION

## FRONT HUB STUB AXLE

– Remove and refit 60.25.22

### Removing

1. Remove the vertical link. 60.25.23.
2. Remove the nyloc nut and plain washer securing the stub axle to the vertical link.
3. Press the stub axle from the vertical link.

### Refitting

4. Reverse instructions 1 to 3.

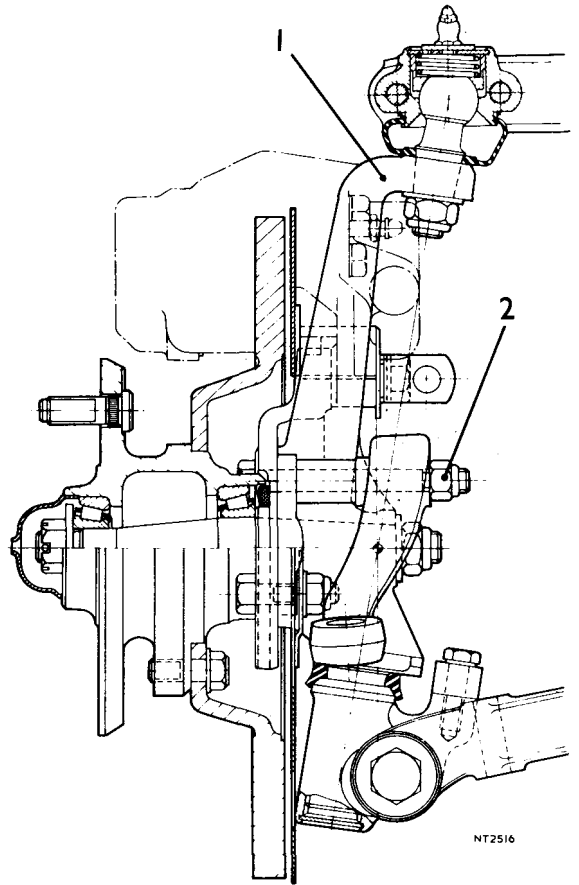

## VERTICAL LINK

– Remove and refit 60.25.23

### Removing

1. Jack up the car and support the chassis on stand(s).
2. Remove the front wheel.
3. Locate a jack under the lower wishbone and compress the road spring to remove tension from the upper ball joint and the lower trunion.
4. Remove the two bolts and spring washers securing the caliper to the mounting plate. Note that the upper bolt also secures the brake hose bracket.
5. Withdraw the caliper from the brake disc taking care that it is subsequently placed or tied in a position so that the weight of the caliper is not supported by the brake pipes or hose.
6. Remove the front hub and disc 60.25.01/02.
7. Remove the nyloc nut and bolt securing the disc lower bracket and mounting plate to the vertical link, and withdraw the disc shield.
8. Remove the two nyloc nuts, bolts and lock plates securing the mounting plate and steering arm to the vertical link.
9. Remove the remaining bolt and lock plate from the mounting plate and withdraw the mounting plate.
10. Remove the nyloc nut and plain washer from the upper ball joint and release the ball joint from the vertical link.
11. Unscrew the vertical link from the lower trunion.

### Refitting

12. Reverse instructions 1 to 11. Ensure that the mounting plate bolts are secured by the lock plates.

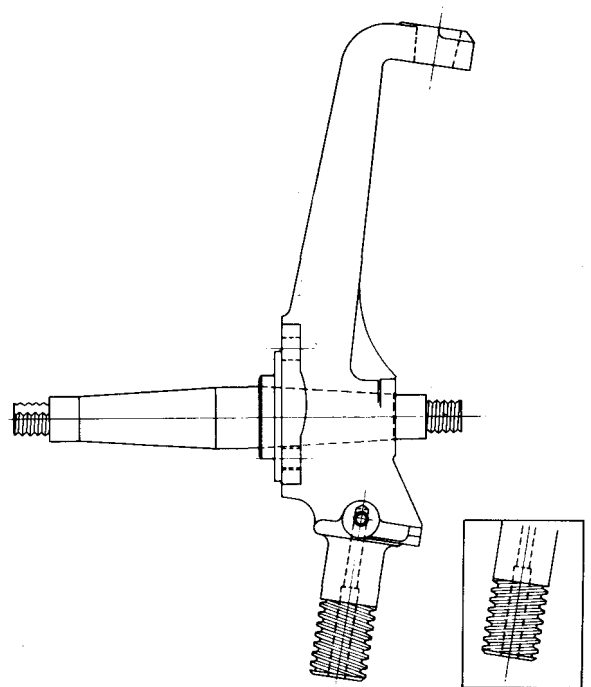

**FRONT HUB WHEEL STUDS**

– Remove and refit

60.25.29

**Removing**

1. Jack up the car and remove the front wheel.
2. *Wire wheels only.* Remove the four nuts securing the hub extension to the hub and withdraw the hub extension.
3. Tap the wheel stud(s) towards the brake disc.
4. Withdraw the stud(s). Wheel stud removal is not advised unless renewal is intended.

**Refitting**

5. Ensure that the mating tapered faces of stud and hub flange are clean.
6. Enter the stud from the brake disc side of the hub.
7. Using suitable packing (e.g. a short length of steel tubing) draw the stud into position with the wheel nut or hub extension nut.
8. Remove the nut and packing.
9. Fit the road wheel (hub extension and road wheel – wire wheel models only) and remove the jack.

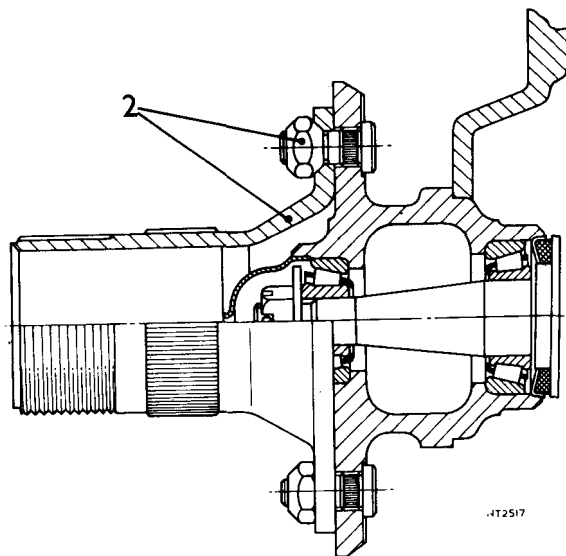
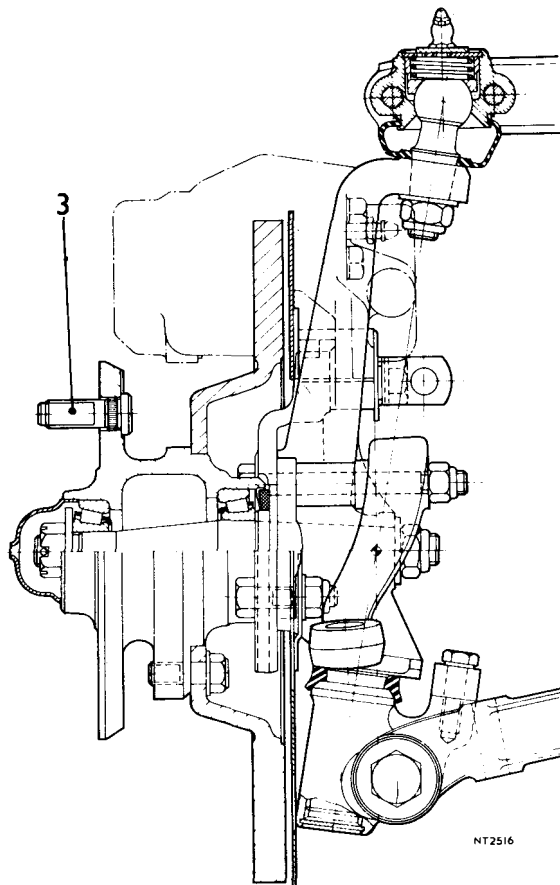

# FRONT SUSPENSION

## FRONT DAMPER

– Remove and refit

60.30.02

### Removing

1. Jack up the car and support the chassis.
2. Remove the road wheel.
3. Remove the four nuts and spring washers securing the damper lower mounting brackets to the underside of the lower wishbone.
4. Remove the locknut and nut, washer and upper rubber mounting from the top of the damper.
5. Withdraw the damper from the lower wishbone and remove the rubber mounting and washer from the damper rod.
6. Remove the bolt and nut securing the damper brackets to the damper.

### Refitting

7. Reverse instructions 1 to 6.

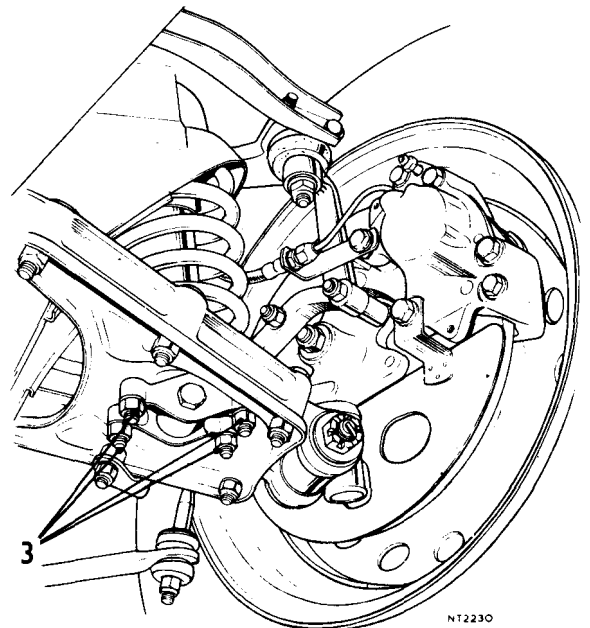
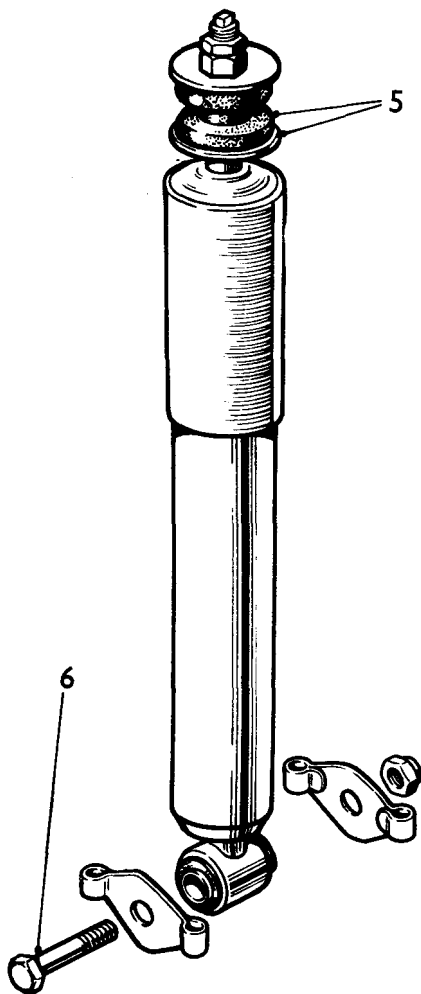
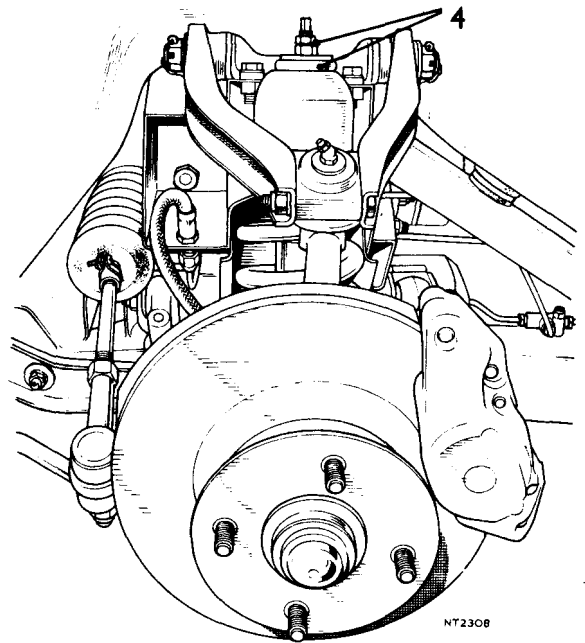

**FRONT DAMPER BUSH**

– Remove and refit 60.30.07

**Removing**

1. Remove the damper from the car 60.30.02.
2. Remove the damper lower bush.

**Refitting**

3. Press new bush into position ensuring that it is centralised in the damper eye.
4. Refit the damper to the car 60.30.02.

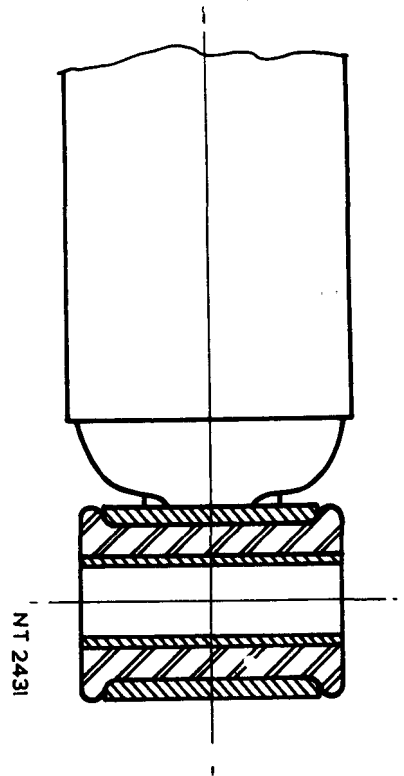

**UPPER WISHBONE**

– Remove and refit 60.35.01

**Removing**

1. Jack up the car, support the chassis and remove the frontwheel.
2. Locate a jack under the spring pad of the lower wishbone and raise the jack to relieve the upper wishbone of road spring tension.
3. Remove the two nuts, plain washers and bolts securing the outer end of the upper wishbone to the ball joint housing.
4. Detach the ball joint housing and the vertical link from the upper wishbone arms. Ensure that strain is not imposed on the front brake hose.
5. Remove the four bolts and spring washers securing the fulcrum bracket to the chassis.
6. Withdraw the fulcrum bracket complete with the upper wishbone arms.
7. Remove the split pins, slotted nuts and plain washers securing the wishbone arms to the fulcrum bracket.
8. Withdraw the wishbone arms complete with rubber bushes.

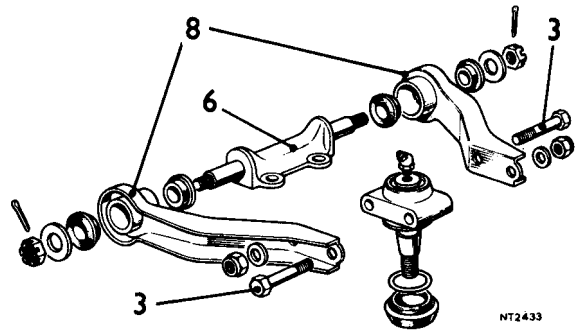

**Refitting**

9. Reverse instructions 1 to 8. When refitting the bolts securing the ball joint housing to the outer ends of the wishbone arms the outer bolt is entered from the rear: the inner bolt is entered from the front.



# FRONT SUSPENSION

## LOWER WISHBONE

– Remove and refit **60.35.02**

### Removing

1. Remove the front road spring 60.20.01.
2. Remove the four nuts and plain washers securing the lower wishbone brackets to the chassis.
3. Withdraw the lower wishbone arms complete with mounting brackets and shims.
4. Remove the nuts and bolts securing the wishbone arms to the mounting brackets and remove the brackets.

### Refitting

5. Reverse instructions 1 to 4.

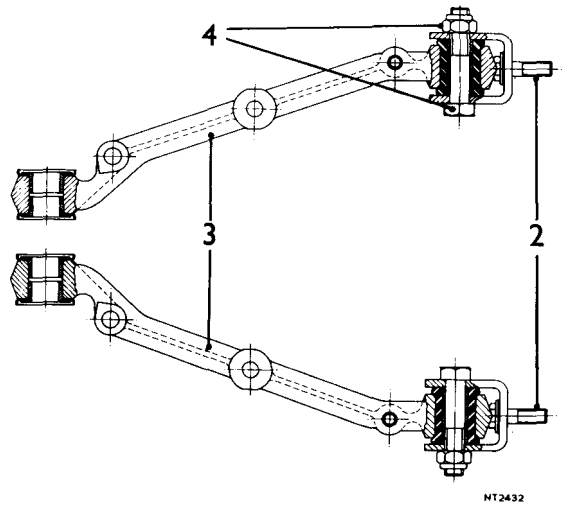

## UPPER WISHBONE

– Overhaul **60.35.08**

1. Remove the upper wishbone 60.35.01.
2. Remove the rubber bushes (4) from the wishbone arms.

### Assembling

3. Fit new rubber bushes (4) to the wishbone arms.
4. Fit the wishbone arms, plain washers and slotted nuts to the fulcrum pin.
5. Tighten the slotted nuts and secure with new split pins.
6. Fit the fulcrum bracket and wishbone to the car 60.35.01.

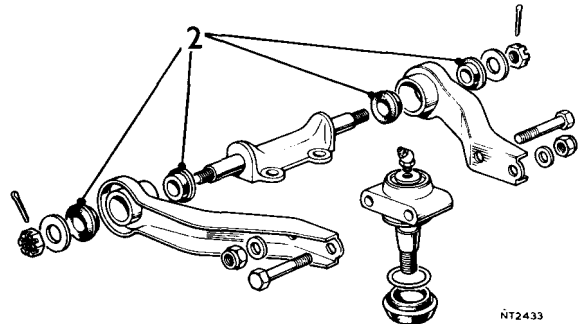

## LOWER WISHBONE

– Overhaul **60.35.09.**

1. Remove the lower wishbone arms from the car 60.35.02.
2. Press out the rubber bushes.
3. Press in new bushes ensuring they are centred in the wishbone arms.
4. Fit the wishbone arms to the car 60.35.02.

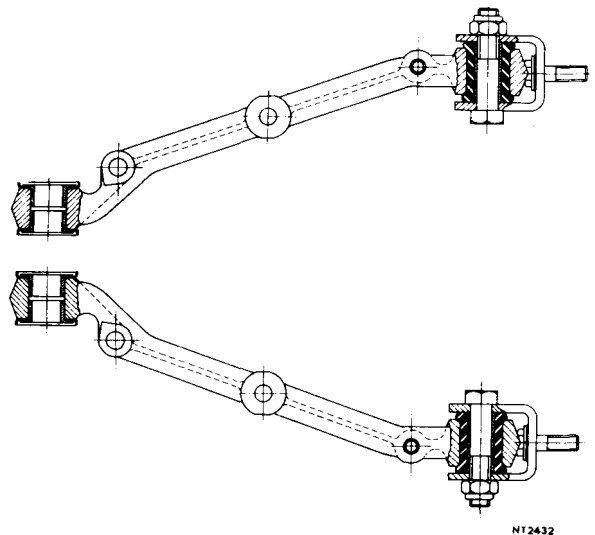

**REAR SUSPENSION OPERATIONS**

Bump stop – remove and refit . . . . .	64.30.15
Rear damper – remove and refit . . . . .	64.30.02
Rear hub and drive shaft assembly	
– remove and refit . . . . .	64.15.01
– hub bearing end-float – check and adjust . . . . .	64.15.13
– hub bearings – remove and refit . . . . .	64.15.14
– hub oil seals – remove and refit . . . . .	64.15.15
– wheel studs – remove and refit . . . . .	64.15.26
Rear spring	
– remove and refit . . . . .	64.20.01
– seat rings – remove and refit . . . . .	64.20.17
Rear wheel alignment – check and adjust . . . . .	64.25.17
Rebound stop – remove and refit . . . . .	64.30.16
Trailing arm	
– remove and refit . . . . .	64.35.02
– bushes – remove and refit . . . . .	64.35.05
– mounting brackets – remove and refit . . . . .	64.35.20



REAR HUB AND DRIVE SHAFT ASSEMBLY

– Remove and refit

64.15.01

Removing

1. Jack up the car and remove the road wheel.
2. Release the handbrake.
3. Remove the four bolts and nyloc nuts securing the drive shaft inner flange to the differential flange.
4. Remove the brake drum.
5. Remove the six nyloc nuts securing the hub bearing housing to the trailing arm.
6. Withdraw the hub assembly and drive shaft complete.

Refitting

7. Reverse instructions 1 to 6.

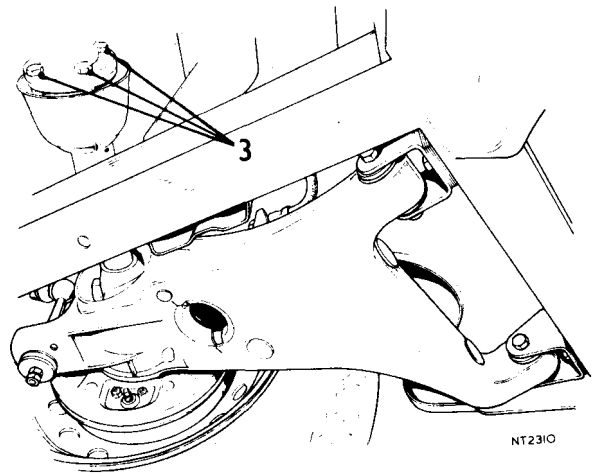

NT2310

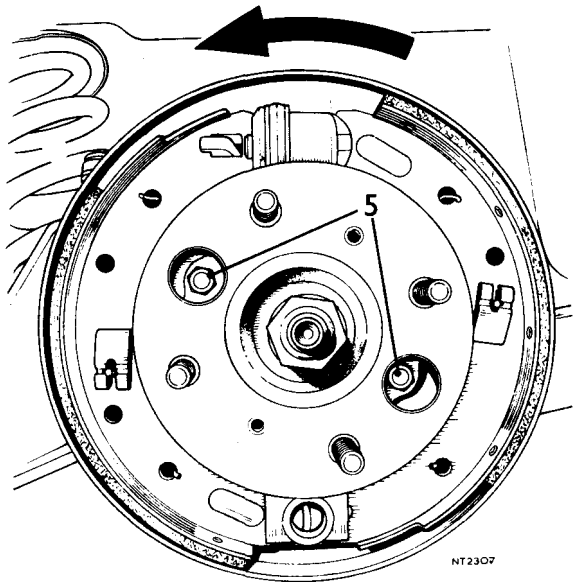

NT2307

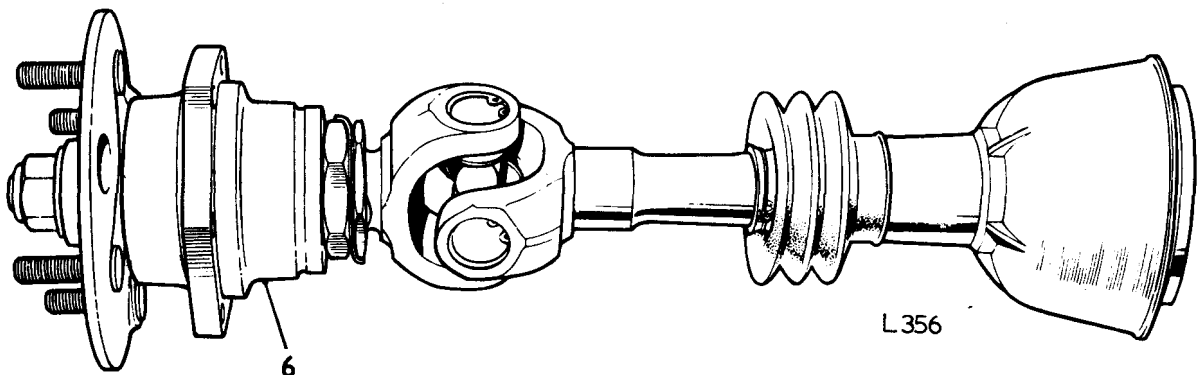

L 356



## REAR SUSPENSION

### REAR HUB BEARING END-FLOAT

– Check and adjust

64.15.13

#### Checking

1. Jack up rear of car and remove the road wheel.
2. Release the handbrake and remove the brake drum.
3. Using a dial gauge with the stylus mounted to contact the hub flange check bearing end-float. Correctly adjusted, end-float should be within 0.002 to 0.005 in (0.051 to 0.13 mm).

#### Adjusting

Service Tools S317, S318

Adjustment to the hub bearings is effected by means of the adjusting nut located behind the rear hub and necessitates the removal of the rear hub and drive shaft assembly from the car 64.15.01.

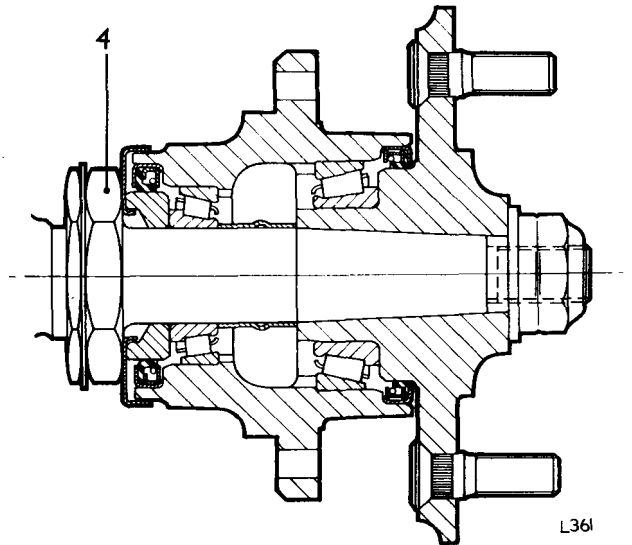

#### Reducing end-float

1. Locate the drive shaft in the holding jig S318.
2. Straighten the tabs on the lock washer.
3. Using a dial gauge check bearing end-float.
4. Screw the adjusting nut towards the hub until end float of 0.002 in (0.051 mm), is obtained. Care must be taken not to reduce end-float below 0.002 in (0.051 mm). Should this occur the collapsible spacer fitted between the hub and the inner bearing must be renewed.
5. Tighten the locknut ensuring that the adjusting nut is held firmly. Bend the locking tabs over the adjusting nut and locknut and examine the condition of the locking tabs. If doubt exists as to their ability to hold the adjusting nut and locknut a new lock washer must be fitted.

#### Increasing end-float

1. Mount the drive shaft in holding jig S318.
2. Carry out instructions 3 to 9, 14 to 19 and 21 to 26, 64.15.14.

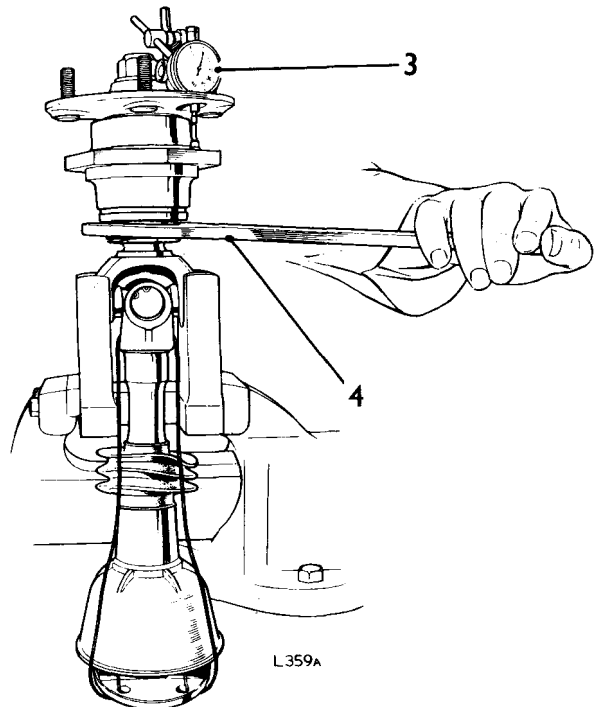



REAR HUB BEARINGS

– Remove and refit

64.15.14

Service Tools S317, S318, M86C, S4221A and S4221A-16

Removing

1. Remove the rear hub and drive shaft assembly. 64.15.01.
2. Mount the hub and drive shaft assembly on tool S318.
3. Remove the nyloc nut and plain washer securing the hub to the stub shaft.
- \*\* NOTE: On later models a castellated nut and split pin is fitted.\*\*
4. Using tool M86C withdraw the hub complete with the outer bearing.
5. Remove the key from the stub shaft.
6. Withdraw the bearing housing.
7. Remove the collapsible spacer, inner bearing and distance piece and stoneguard from the stub shaft.
8. Straighten the locking tabs securing the bearing adjusting nuts and remove adjusting nut, tab washer and locknut.
9. Remove the inner and outer oil seals from the bearing housing.
10. Remove the inner and outer bearing tracks from the bearing housing. Bearing outer tracks should not be disturbed unless renewal is intended.
11. Remove the outer bearing (Tool S4221A and adaptor 16).
12. Thoroughly clean all components.

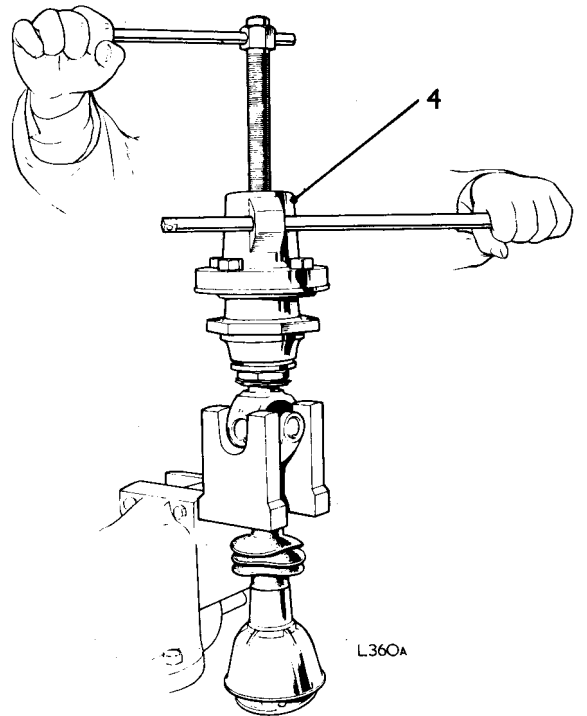
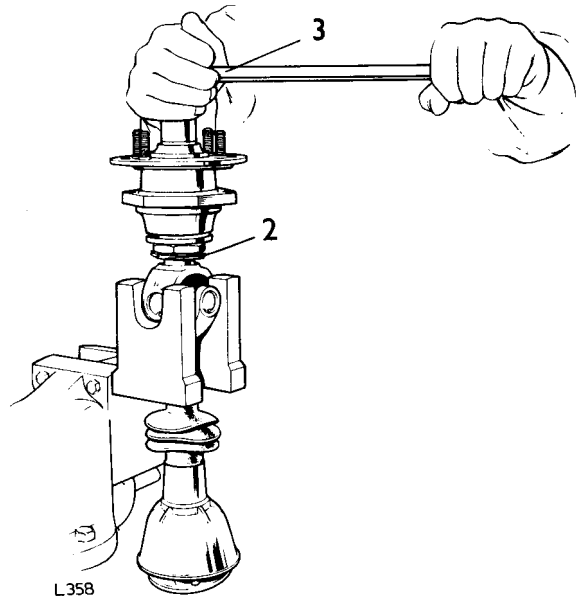

Continued

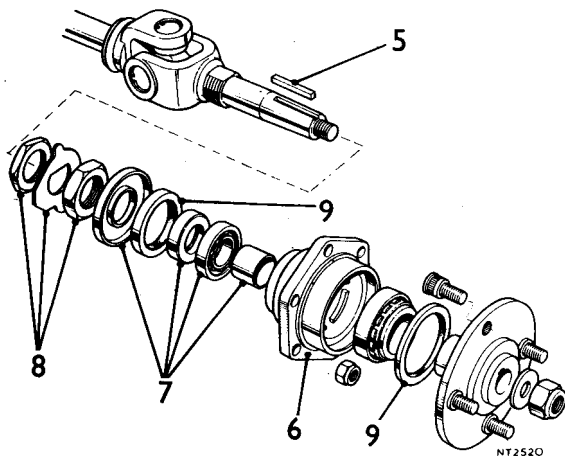

## REAR SUSPENSION

### Refitting

13. Evenly press or drift the inner and outer bearing tracks into position in the bearing housing.
  14. Fit new inner and outer oil seals to the bearing housing (Seal lip towards bearing track).
  15. Fit the locknut, new tab washer and adjusting nut to the stub shaft, and screw both nuts as close to the universal joint as possible.
  16. Fit the stoneguard, distance piece, inner bearing and a new collapsible spacer to the stub shaft.
  17. Fit the key to the stub shaft.
  18. Half fill the bearing housing with grease.
  19. Install the bearing housing on the stub shaft.
  20. Fit the outer bearing to the hub.
  - 21.\*\* Fit the hub, plain washer and nyloc nut (or castellated nut – later models) to the stub shaft. Tighten nut to the correct torque, see Page 06-4, and fit the split pin to the castellated nut on later models.\*\*
  22. Screw adjusting nut by hand towards the bearing housing until bearing end-float approaches 0.002 in (0.051 mm).
  23. Using a dial gauge, check bearing end-float.
  24. Using tool S317, carefully continue to screw the adjusting nut towards the bearing housing until bearing end float of 0.002 in (0.051 mm) is obtained. 0.13 mm is obtained.
- NOTE:** Care must be taken not to reduce bearing end-float to less than 0.002 in (0.051 mm), as this will necessitate stripping the hub and renewing the excessively compressed collapsible spacer.
25. Ensure that the adjusting nut is not disturbed and tighten the locknut.
  26. Bend the locking tabs over the adjusting nut and locknut.

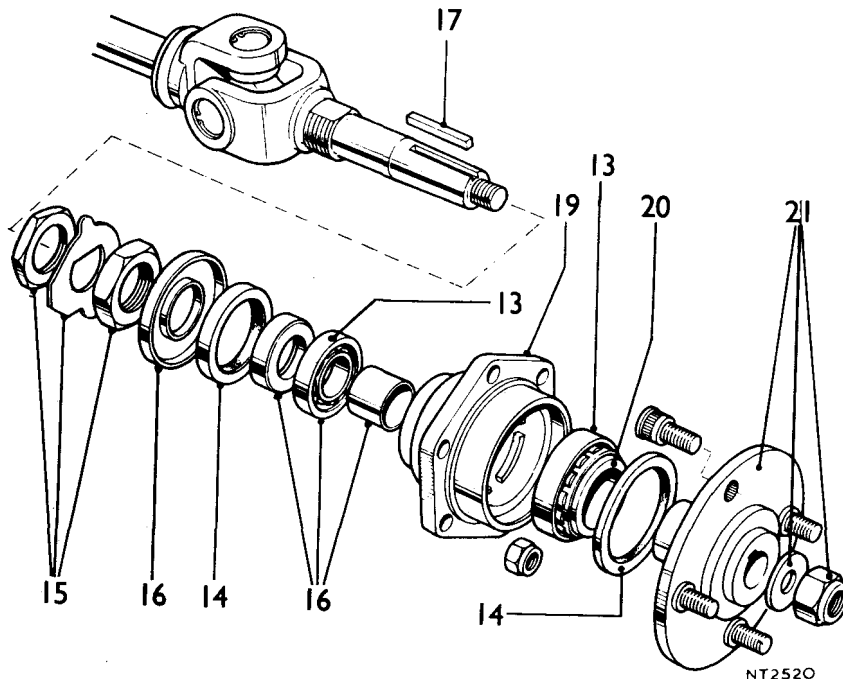
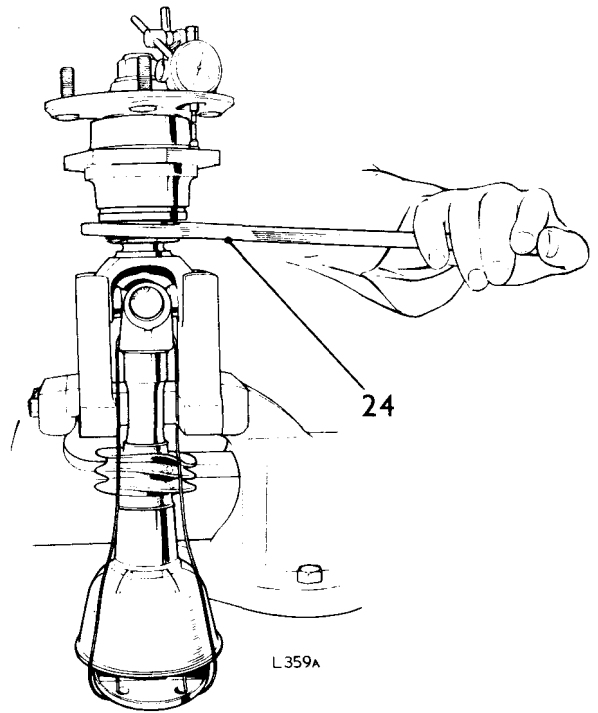

## REAR HUB OIL SEALS

Service Tools S317, S318, M86C

– Remove and refit 64.15.15

Instructions 1 to 9, 14 to 19 and 21 to 26, 64.15.14.

## REAR HUB WHEEL STUD

– Remove and refit 64.15.26

### Removing

1. Remove the rear brake drum 70.10.03.
2. Tap the wheel stud towards the brake backplate until the stud splines are released from the hub flange.
3. Remove the stud.

### Refitting

4. Enter the stud in the hub flange ensuring that the tapered faces are clean.
5. Using suitable packing (e.g. a short length of steel tubing and washers) draw the stub into position.
6. Remove the packing and fit the brake drum, and road wheel 70.10.03.

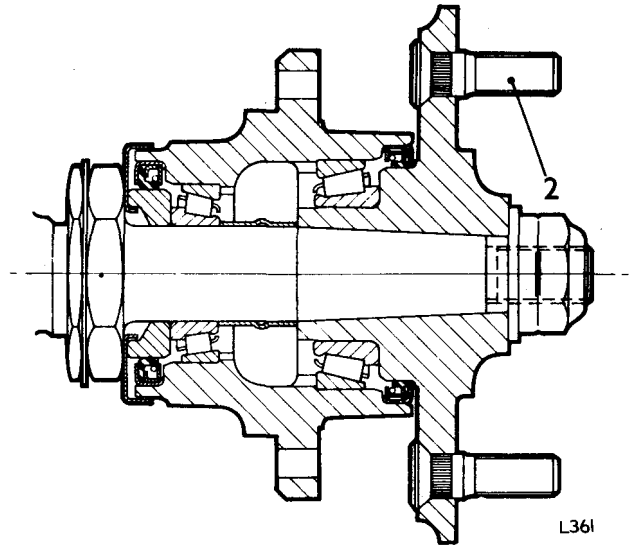

## REAR SPRING

– Remove and refit 64.20.01

### Removing

1. Jack up the car and support the chassis on stand(s).
2. Remove the road wheel and release the handbrake.
3. Support the trailing arm with a jack.
4. Remove the locknut, nut, washers and rubbers securing the damper link to the trailing arm.
5. Carefully lower the jack under the trailing arm until the road spring is released of tension.
6. Withdraw the road spring and the upper and lower rubber insulating rings.

### Refitting

7. Reverse instructions 1 to 7.

## REAR SPRING SEAT RINGS

– Remove and refit 64.20.17

As Operation 64.20.01.

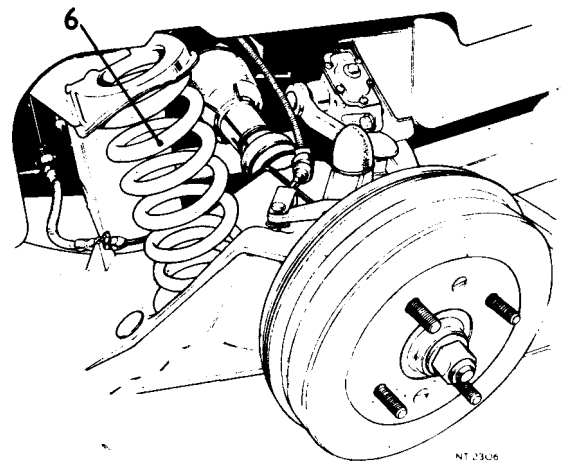
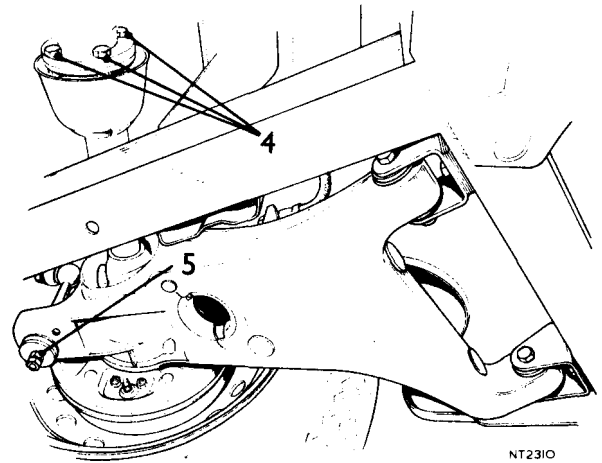

## REAR SUSPENSION

### REAR WHEEL ALIGNMENT

– Check and adjust 64.25.17

#### Checking

Rear wheel toe-in should be within 0 to 1/16 in (0 to 1.58 mm).

#### Adjusting

In contrast to the front wheel track where adjustment is made equally to both tie rods to maintain balanced steering lock angles, adjustment to rear wheel track is individual to either wheel and is determined by alignment with its respective front wheel to which it should have a tolerance of 0 to 1/32 in (0 to 0.313 mm) toe-in.

1. Slacken the two bolts and nuts securing the trailing arm outer bracket to the chassis.
2. Using a tyre lever, prise the trailing arm outer bracket away from the chassis.
3. Withdraw the shim pack,
4. Add shim(s) to reduce toe-in: remove shim(s) to increase toe-in.
5. Install the shim pack and tighten the bracket securing bolts.
6. Drive the vehicle forward or backward before rechecking rear toe-in.

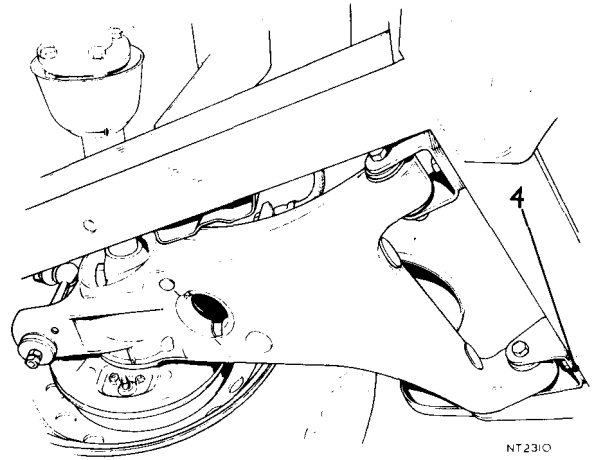

### REAR DAMPER

– Remove and refit 64.30.02

#### Removing

1. Jack up the car and support the chassis on stand(s) and remove the rear wheel.
2. Locate a jack under the trailing arm and raise the jack until the road spring is slightly compressed.
3. Remove the locknut, nut, washers and rubber securing the damper link to the trailing arm.
4. Remove the two bolts securing the damper to the chassis.
5. Withdraw the damper complete with damper link and upper washer and rubber.
6. Remove the nut and spring washer securing the link to the damper.
7. Release the link from the damper.

#### Refitting

8. Reverse instructions 1 to 7.

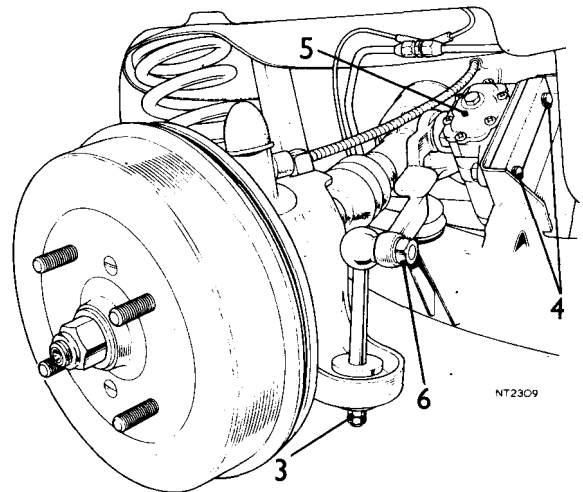

## BUMP STOP

– Remove and refit

64.30.15

### Removing

1. Jack up the car and remove the rear wheel.
2. Unscrew the bump stop from the trailing arm.

### Refitting

3. Reverse instructions 1 and 2.

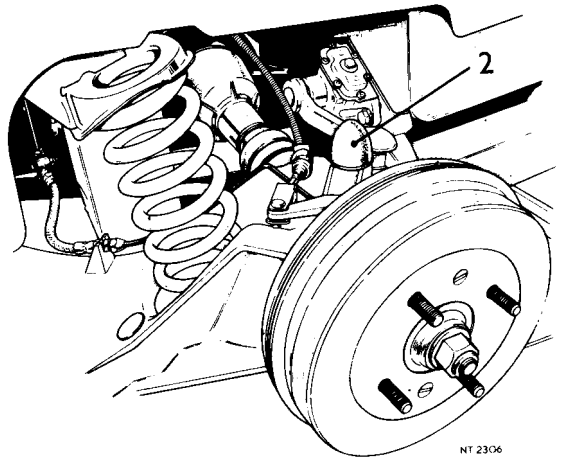

## REBOUND STOP

– Remove and refit

64.30.16

### Removing

1. Position a jack under the rear trailing arm and raise jack.
2. Remove the rear wheel.
3. Unscrew the rebound stop.

### Refitting

4. Reverse instructions 1 to 3.

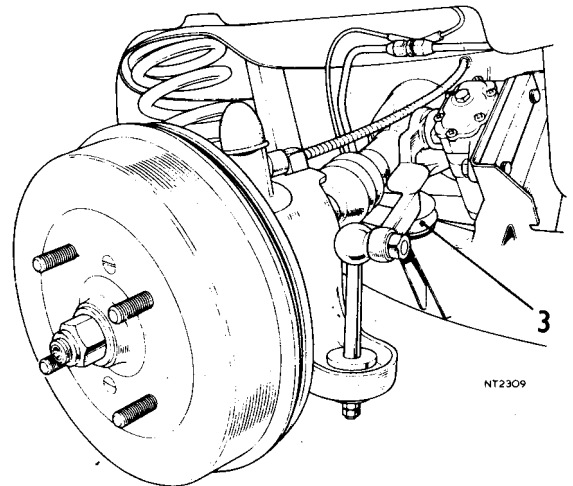

## REAR SUSPENSION

### TRAILING ARM

– Remove and refit

64.35.02

#### Removing

1. Jack up rear of car and support chassis on stand(s).
2. Remove the road wheel and release the handbrake.
3. Disconnect the handbrake cable bracket from the trailing arm.
4. Position a jack under the trailing arm and partially compress the road spring taking care not to remove the weight from the chassis stand(s).
5. Remove the rear hub and drive shaft assembly 64.15.01.
6. Remove the locknut, nut, washer and rubber mounting from the lower end of the damper link.
7. Slacken the locknut securing the flexible hose to the trailing arm bracket, detach the hose and unclip the brake pipe from the trailing arm.
8. Carefully lower the jack and withdraw the road spring and the spring upper and lower insulating rings.
9. Remove the nut and bolt securing the trailing arm to the outer mounting bracket.
10. Remove the two nuts and washers securing the trailing arm inner mounting bracket to the chassis and withdraw the shim pack.
11. Withdraw the trailing arm complete with the inner mounting bracket.
12. Remove the bolt and nut securing the inner bracket to the trailing arm. If required remove the bump and rebound stops.

#### Refitting

13. Reverse instructions 1 to 12. Do not finally tighten the trailing arm pivot bolts until the car is resting on its wheels.

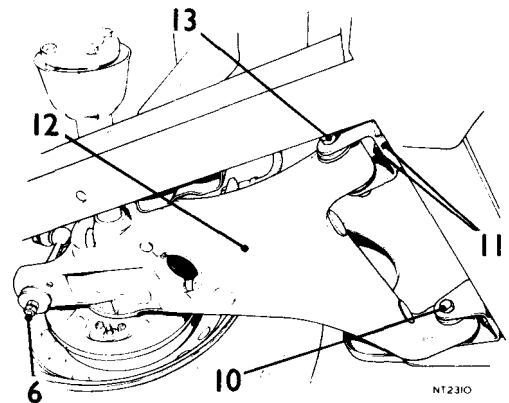
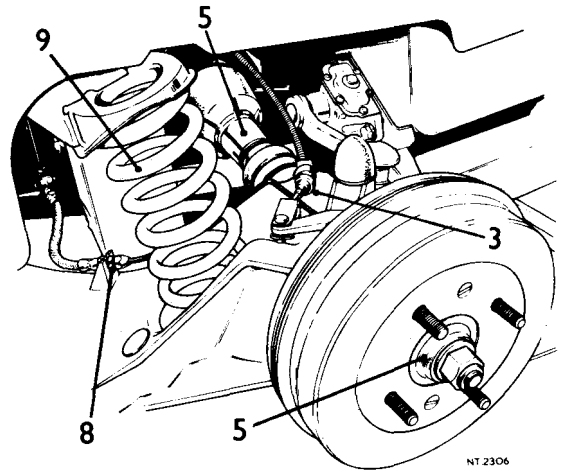

### TRAILING ARM BUSHES

– Remove and refit

64.35.05

#### Removing

1. Remove the trailing arm 64.35.02.
2. Press out the trailing arm bushes.

#### Refitting

3. Press in new bushes to the trailing arm.
4. Fit the trailing arm to the car 64.35.02.
5. Bleed the brakes.

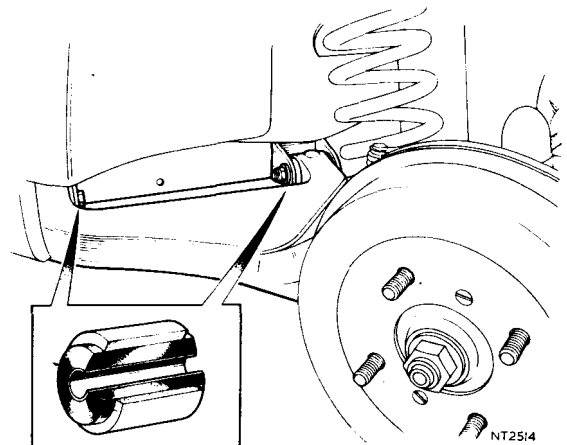

**TRAILING ARM MOUNTING BRACKETS**

– Remove and refit

64.35.20

**Removing**

1. Remove the rear road spring 64.20.01.
2. Remove the outer pivot bolt and nut securing the trailing arm to the mounting bracket.
3. Remove the two nuts and washers securing the inner mounting bracket to the chassis and withdraw the shim pack.
4. Detach the trailing arm and outer bracket from the car.
5. Remove the nut and bolt securing the outer bracket to the trailing arm.
6. Remove the two nuts, washers and bolts securing the inner bracket to the chassis and withdraw the bracket and shim pack. Ensure shim packs are not intermixed.

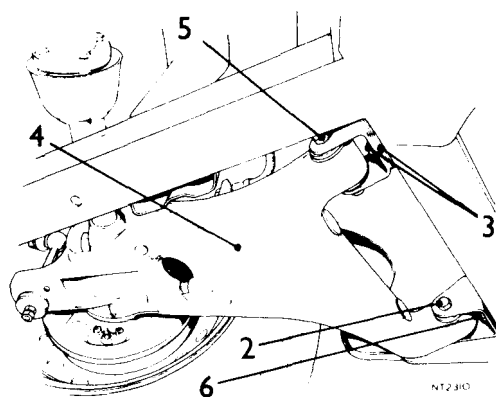

**Refitting**

7. Reverse instructions 1 to 6. Do not finally tighten the trailing arm pivot bolts until the car is resting on its wheels.

## BRAKE OPERATIONS

Brakes	
– adjust	70.25.03
– bleed	70.25.02
Brake pedal assembly – remove and refit	70.35.01
Connector – 2-way – remove and refit	70.15.32
– 3-way – front – remove and refit	70.15.33
– 3-way – rear – remove and refit	70.15.34
Flexible hose	
– front – remove and refit	70.15.02/03
– rear – remove and refit	70.15.17/18
Front caliper – remove and refit	70.55.02
– disc – remove and refit	70.10.10
– disc shield – remove and refit	70.10.18
– overhaul	70.55.13
– pads – remove and refit	70.40.01
Handbrake	
– cable – adjust	70.35.10
– cables – set – remove and refit	70.35.16
– compensator – remove and refit	70.35.11
– lever assembly – remove and refit	70.35.08
Master cylinder	
– overhaul	70.30.09
– remove and refit	70.30.08
– reservoir – remove and refit	70.30.15
P.D.W.A. – remove and refit	70.15.36
Rear brake	
– adjuster – remove and refit	70.40.17
– backplate – remove and refit	70.10.26
– drum – remove and refit	70.10.03
– shoes – remove and refit	70.40.03
Rear wheel cylinder	
– overhaul	70.60.26
– remove and refit	70.60.18
Servo	
– filter – remove and refit	70.50.25
– remove and refit	70.50.01



**REAR BRAKE DRUM**

– Remove and refit **70.10.03**

**Removing**

1. Jack up the car and remove the rear wheel.
2. Release the handbrake.
3. Remove the two countersunk screws securing the brake drum to the hub.
4. Withdraw the brake drum.

**Refitting**

5. Align the countersunk holes in the drum with the tapped holes in the hub.
6. Engage the wheel studs in the drum.
7. Slide the brake drum into position. If the brake shoes were disturbed they may require to be centralised on the backplate to allow drum entry.
8. Fit and tighten the two countersunk screws.
9. Fit the road wheel and remove the jack.

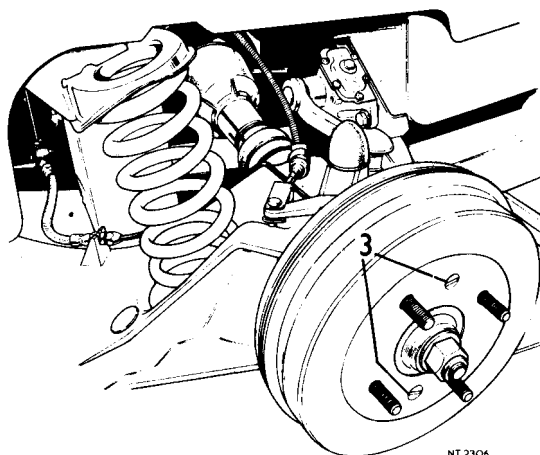

NT 2306

**FRONT DISC**

– Remove and refit **70.10.10**

**Removing**

1. Jack up the car and remove the front wheel.
2. Detach the caliper and remove the front hub 60.25.01/02.
3. Remove the four bolts and spring washers securing the disc to the hub flange.
4. Withdraw the disc.

**Refitting**

5. Reverse instructions 1 to 4.

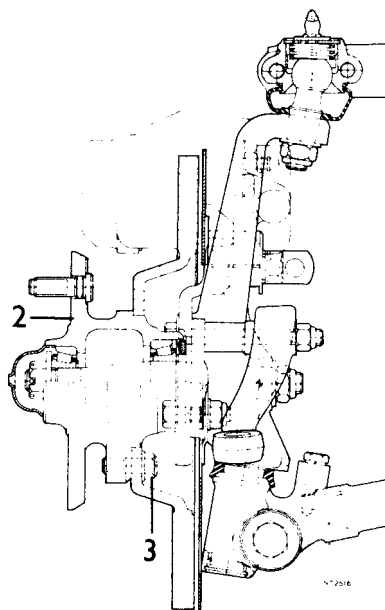

NT 2316

**FRONT DISC SHIELD**

– Remove and refit **70.10.18**

**Removing**

1. Remove the front hub 60.25.01/02.
2. Slacken the front lower nut, washer and bolt securing the disc mounting lug to the vertical link.
3. Withdraw the disc shield.

**Refitting**

4. Reverse instructions 1 to 3.

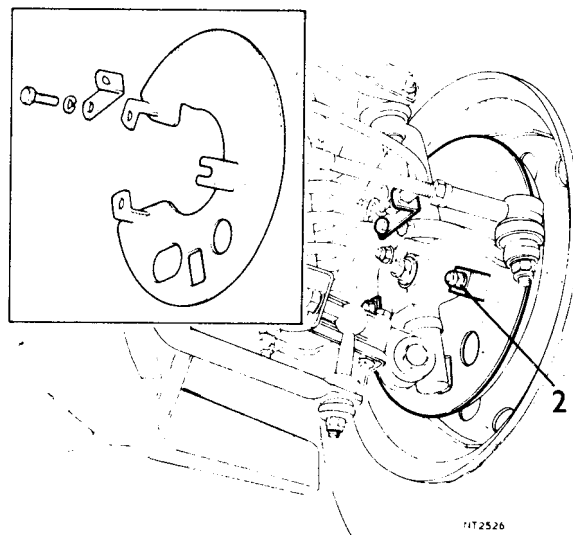

NT 2526



# BRAKES

## REAR BRAKE BACK PLATE

– Remove and refit 70.10.26

### Removing

1. Remove the rear road wheel and brake drum 70.10.03.
2. Remove brake shoes. 70.40.03 and disconnect the handbrake cable at the backplate lever.
3. Disconnect the drive shaft flange at differential.
4. Disconnect the brake pipe at rear brake cylinder.
5. Remove the six nuts securing the rear hub and backplate to the trailing arm.
6. Withdraw the rear hub complete with drive shaft.
7. Withdraw the backplate.

### Refitting

8. Reverse instructions 1 to 7.
9. Bleed the brakes.

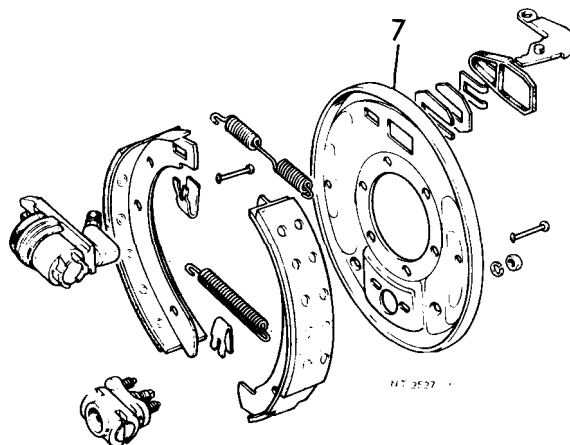
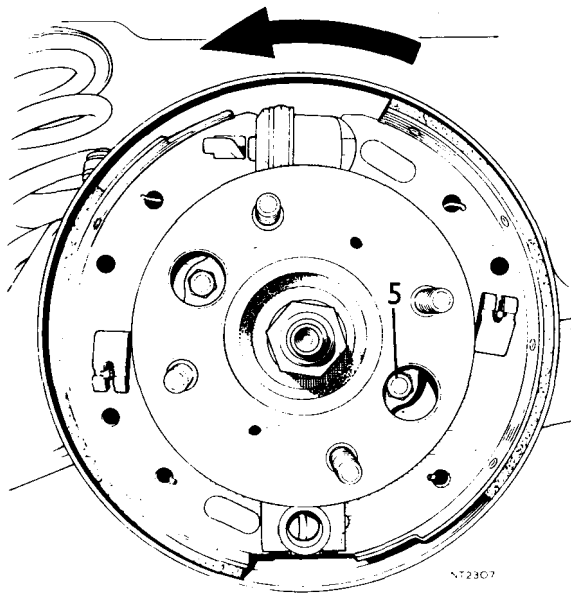

## FRONT HOSE

– Remove and refit 70.15.02/03

### Removing

1. Jack up the car and remove the front wheel.
2. Disconnect the brake pipe union at hose/caliper bracket.
3. Disconnect the brake pipe union at the chassis bracket.
4. Remove the nuts and lockwashers securing the hose ends to the caliper and chassis brackets.
5. Remove the flexible hose.

### Refitting

6. Fit the hose ends to the caliper and chassis brackets and secure with lockwashers and nuts. Ensure that the hose is neither kinked nor twisted on installation.
7. Fit the brake pipes to the hose ends.
8. Fit the road wheel and remove the jack.
9. Bleed the brakes.

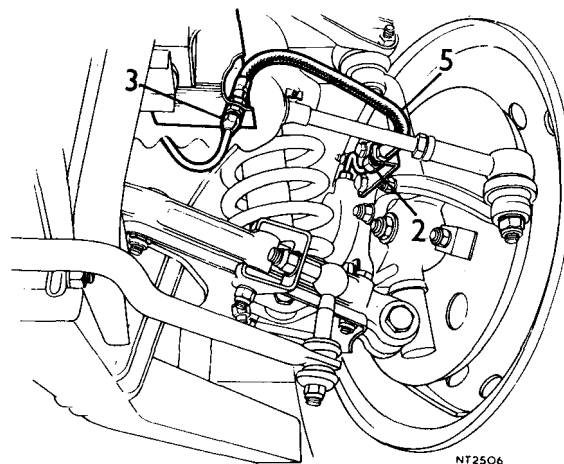

70.10.26

70.15.03

**REAR HOSE**

– Remove and refit

70.15.17/18

**Removing**

1. Jack up the car and remove the rear wheel.
2. Disconnect the brake pipe union and brake pipe from the wheel cylinder to the flexible hose.
3. Remove the nut and lockwasher securing the flexible hose to the trailing arm.
4. Disconnect the pipe union from the front end of the flexible hose. Remove the nut and lockwasher securing the hose to the chassis bracket and withdraw the hose.

or

Unscrew the hose from the 3-way connector.

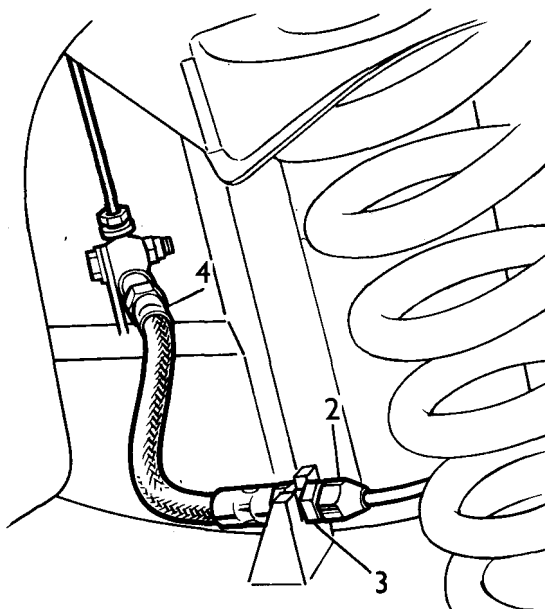

**Refitting**

5. Fit the hose to the chassis bracket and secure with lockwasher and nut. Connect the brake pipe from the 3-way connector

or

Fit the hose to the 3-way connector.

6. Fit the hose to the trailing arm bracket and secure with lockwasher and nut. Ensure that the hose is neither kinked nor twisted on installation.
7. Connect the wheel cylinder pipe to the hose.
8. Fit the rear wheel and remove the jack.
9. Bleed the brakes.

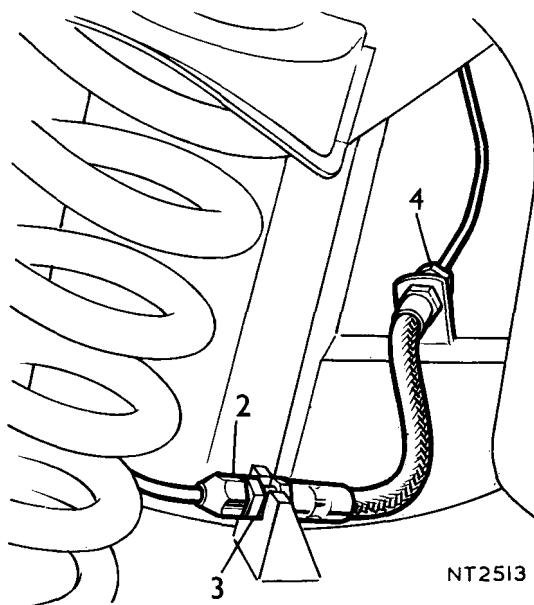

NT2513

**2-WAY CONNECTOR**

– Remove and refit

70.15.32

**Removing**

1. Disconnect the brake pipe unions from the connector.
2. Release the connector from the pipes.

**Refitting**

3. Reverse instructions 1 and 2.
4. Bleed the brakes.

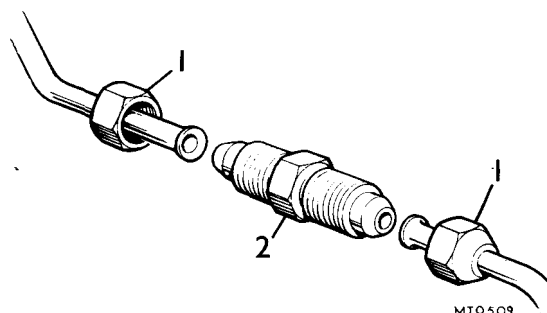

MT0509



## BRAKES

### 3-WAY CONNECTOR – FRONT

– Remove and refit

70.15.33

#### Removing

1. Disconnect brake pipe unions (3) and release the pipes from the connector.
2. Remove the nut and bolt securing the connector to the chassis bracket and withdraw the connector.

#### Refitting

3. Connect, but do not tighten the brake pipes and unions (3) to the connector.
4. Fit the connector to the chassis bracket and secure with nut and bolt.
5. Tighten the pipe unions (3).
6. Bleed the brakes.

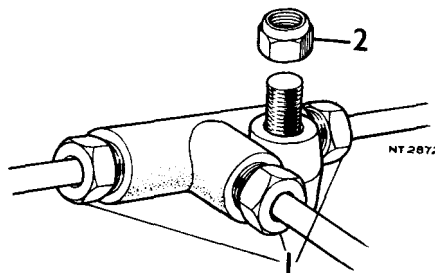

### 3-WAY CONNECTOR – REAR

– Remove and refit

70.15.34

#### Removing

1. Jack up the car and remove the rear wheel on the driver's side of car.
2. Disconnect the brake pipe union from the flexible brake hose.
3. Remove the nut and lockwasher securing the hose to the trailing arm.
4. Unscrew the hose from the 3-way connector.
5. Disconnect the two brake pipe unions from the 3-way connector.
6. Remove the nut and bolt securing the connector to the chassis bracket and withdraw the connector.

#### Refitting

7. Reverse instructions 1 to 6. Ensure that the flexible hose is neither kinked nor twisted on installation.
8. Fit the rear wheel and remove the jack.
9. Bleed the brakes.

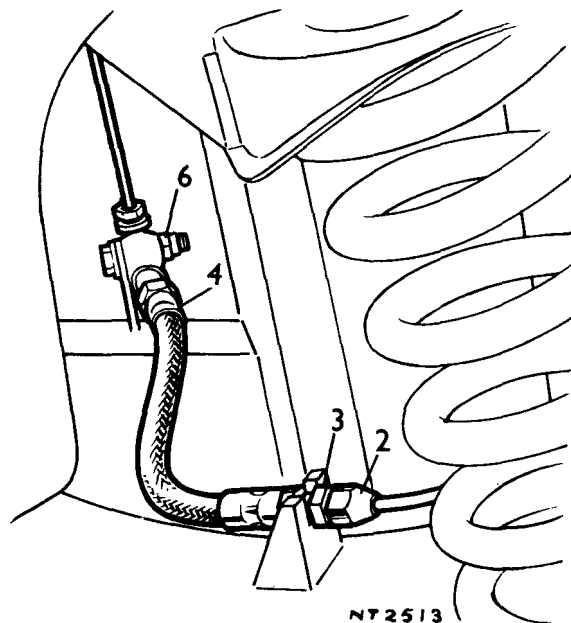

### P.D.W.A. SWITCH

– Remove and refit

70.15.36

#### Removing

1. Disconnect the electrical plug from the P.D.W.A. unit.
2. Disconnect the four brake pipes from the P.D.W.A. unit.
3. Remove the bolt and spring washer securing the P.D.W.A. unit to the car.
4. Remove the P.D.W.A. unit.

#### Refitting

5. Fit the P.D.W.A. unit to the car and secure with bolt and spring washer.
6. Fit the four brake pipes to the P.D.W.A. unit.
7. Connect the electrical plug to the P.D.W.A. unit.
8. Bleed the brakes.

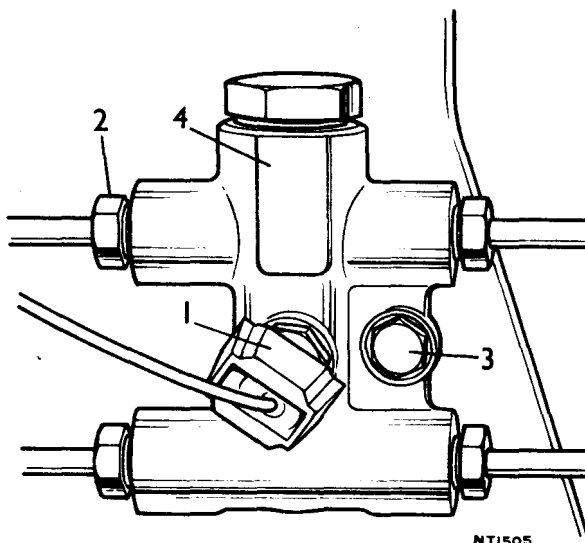

70.15.33

70.15.36

**HYDRAULIC PIPES**

– Remove and refit

Pipe – P.D.W.A. to 3-way – front	70.20.01
Pipe – 3-way – front – to L.H. hose	70.20.02
Pipe – 3-way – front – to R.H. hose	70.20.03
Pipe – hose to front caliper L.H.	70.20.08
Pipe – hose to front caliper R.H.	70.20.09
Pipe – 2-way connector to rear 3-way connector	70.20.14
Pipe – rear 3-way connector to rear hose R.H.	70.20.16
Pipe – hose to rear cylinder L.H.	70.20.17
Pipe – hose to rear cylinder R.H.	70.20.18
Pipe – P.D.W.A. to 2-way connector	70.20.27
Pipe – master cylinder to P.D.W.A. – front brakes	70.20.46
Pipe – master cylinder to P.D.W.A. – rear brakes	70.20.47

**Removing**

1. Disconnect the brake pipe unions at pipe ends.
2. Release the pipe from securing clips (where fitted).
3. Withdraw the pipes.

**Refitting**

4. Locate the pipe in position on the car.
5. Connect the pipe unions at pipe ends to their respective components.
6. Secure the pipe to the pipe clips (where fitted).
7. Bleed the brakes.

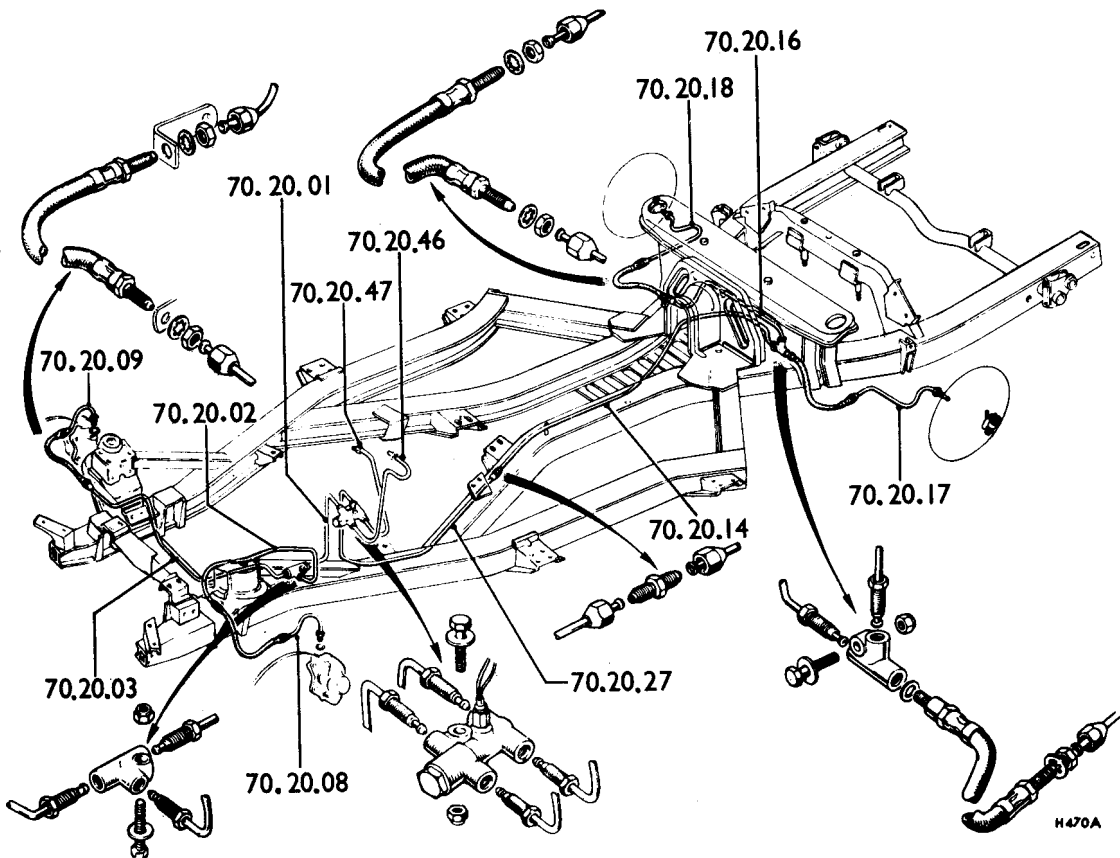

## BRAKES – BLEED

70.25.02

1. Check the level of fluid in the master cylinder reservoir and top up as necessary.
2. Depress the brake pedal to destroy the vacuum in the servo. Do not bleed the brakes with the engine running.
3. Attach a bleed tube to the nipple of the rear wheel cylinder farthest (longest pipe run) from the master cylinder. Allow the free end of the tube to hang submerged in brake fluid in a transparent container.
4. Slacken the bleed nipple (90° to 180° is usually adequate) and depress the brake pedal. On models fitted with a Pressure Differential Warning Actuator (P.D.W.A.) do not apply either hard pressure or full travel to the brake pedal in order to avoid moving P.D.W.A. shuttle out-of-centre.
5. Allow the brake pedal to return to its idle position and again depress. Continue until fluid discharge from the wheel cylinder is seen to be free of air bubbles.
6. Hold the brake pedal depressed, close the bleed nipple and remove the bleed tube.
7. Repeat above procedure on the opposite rear wheel cylinder.
8. Bleed the front calipers in similar manner commencing at the caliper farthest from the master cylinder.
9. Check the fluid level in the reservoir and top up. It is important to ensure that the reservoir fluid is never permitted to fall so low that air can be admitted to the master cylinder. When topping up the reservoir do not use the aerated and possibly contaminated fluid discharged during the process of bleeding.
10. *P.D.W.A. models only.* Switch on the ignition and observe the brake failure light for indication that the P.D.W.A. is centralised. (Both the oil warning light and the brake failure warning light glowing dimly). A brightly glowing brake failure light and no illumination from the oil warning light is indicative that the P.D.W.A. shuttle has been displaced. To re-centre the shuttle it is necessary to open the bleed nipple on the circuit opposite to that to which the shuttle has moved and depress the brake pedal until the brake failure light and the oil light glows.

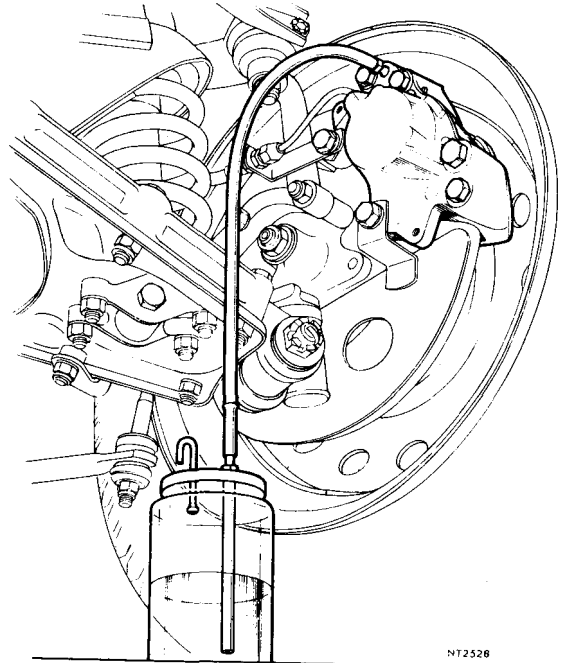

## BRAKES

-Adjust

70.25.03

## Front

The front brakes are hydraulically self-adjusting to compensate for brake pad wear. Manual adjustment is not provided.

## Rear

A single wedge-type adjuster with a square-ended spindle is provided on the backplate.

1. Jack up rear of car until both wheels are free of ground contact.
2. Release the handbrake.
3. Rotate the adjuster spindle clockwise (viewed from the rear of backplate) until the wheel is locked.
4. Rotate the adjuster anti-clockwise until the wheel can be turned freely.
5. Repeat instructions 3 and 4 on opposite rear wheel. Failure of an adjuster to lock a rear wheel is indicative of excessively worn brake linings.
6. Remove the jack.

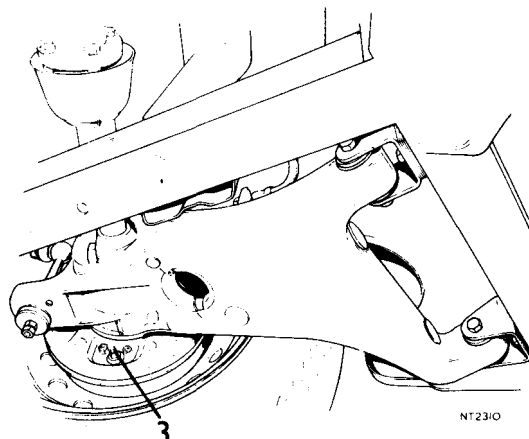

## MASTER CYLINDER

- Remove and refit

70.30.08

## Removing

1. Disconnect the two brake pipe unions from the master cylinder and seal the brake pipes to prevent ingress of foreign matter.
2. Remove the two nuts and spring washers securing the master cylinder to the servo.
3. Withdraw the master cylinder.

## Refitting

4. Fit the master cylinder to the servo and secure with spring washers and nuts.
5. Connect the brake pipes to the master cylinder.
6. Top up the reservoir.
7. Bleed the brakes.

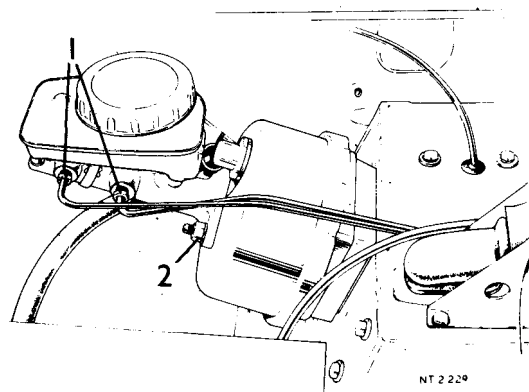

# BRAKES

## MASTER CYLINDER

– Overhaul

70.30.09

### Dismantling

1. Remove the master cylinder from the servo 70.30.08 and drain the brake fluid.
2. Remove the four screws (underside of reservoir) securing the reservoir to the master cylinder and lift off the reservoir.
3. Withdraw the reservoir sealing rings (two).
4. Push the master cylinder secondary plunger slightly into the bore to allow the tipping valve to seat.
5. Maintaining slight pressure on the secondary plunger, remove the tipping valve. Release the plunger.
6. Withdraw the primary and secondary plungers complete with seals and springs.
7. Separate the plungers and the intermediate spring.
8. Prise up the leaf of the spring retainer and remove the spring and valve sub-assembly from the secondary plunger.
9. Withdraw the valve, spacer, spring washer and valve seal from the valve head.
10. Remove the seals from the primary and secondary plungers.
11. Thoroughly clean all components.
12. Examine the cylinder bore for wear, scoring and corrosion. If damage or wear is evident a new cylinder must be obtained.

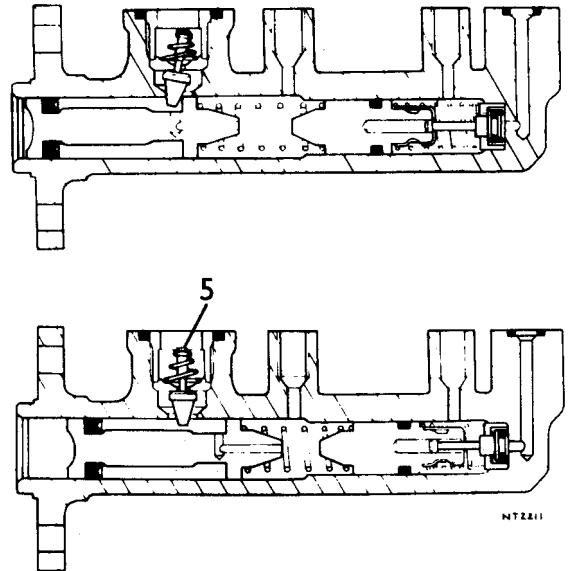

### Assembling

13. Fit new seals to the primary and secondary plungers.
14. Fit a new valve seal to the valve head.
15. Place the spring washer on the valve stem (convex side of washer adjacent to the valve).
16. Fit the valve spacer, legs leading.
17. Fit the spring retainer to the valve stem, keyhole leading.
18. Slide the secondary spring over the spring retainer and offer up the secondary plunger.
19. Place the secondary plunger and valve assembly between the jaws of a vice covered with clean paper. Compress the spring and using a small screwdriver press the spring retainer hard against the secondary plunger. Holding the retainer in this position, depress the leaf of the spring retainer hard against the plunger. Remove the plunger and valve assembly from the vice and check that the retainer is firmly secured in the plunger.
20. Fit the intermediate spring between the primary and secondary plungers.
21. Generously lubricate the cylinder bore and plungers with clean brake fluid and insert the plungers in the cylinder.
22. Depress the secondary plunger and fit the tipping valve.
23. Renew the reservoir sealing rings and fit the reservoir.

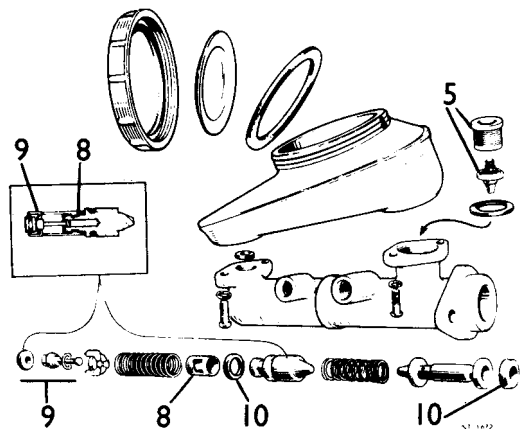



**FLUID RESERVOIR**

– Remove and refit **70.30.15**

**Removing**

1. Remove the master cylinder 70.30.08.
2. Drain the reservoir and master cylinder.
3. Remove the four screws (underside of reservoir) securing the reservoir to the master cylinder.
4. Lift off the reservoir and remove the two sealing rings.

**Refitting**

5. Fit new sealing rings.
6. Fit the reservoir to the master cylinder and evenly tighten the four securing screws.

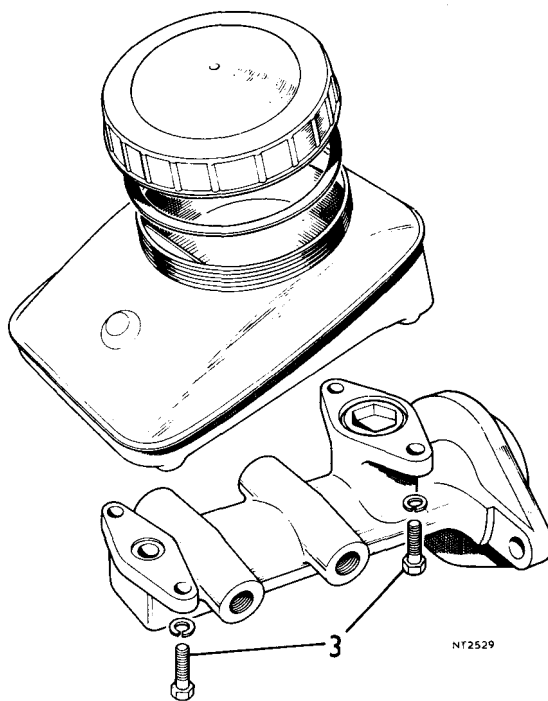

**PEDAL ASSEMBLY**

– Remove and refit **70.35.01**

**Removing**

1. Remove the two nuts, spring washers and bolts securing the accelerator pedal bracket to the pedal box.
2. Release the accelerator pedal return spring.
3. Remove the spring clip and release the accelerator cable from the accelerator pedal.
4. Withdraw the accelerator pedal.
5. Disconnect the two spade terminals from the brake stop switch.
6. Remove the four nuts and plain washers securing the servo to the pedal box.
7. Remove the four bolts and spring washers securing the clutch master cylinder bracket to the scuttle.
8. Remove the seven bolts, plain washers and spring washers securing the pedal box to the scuttle.
9. Withdraw the pedal box assembly.

**Refitting**

10. Reverse instructions 1 to 9.

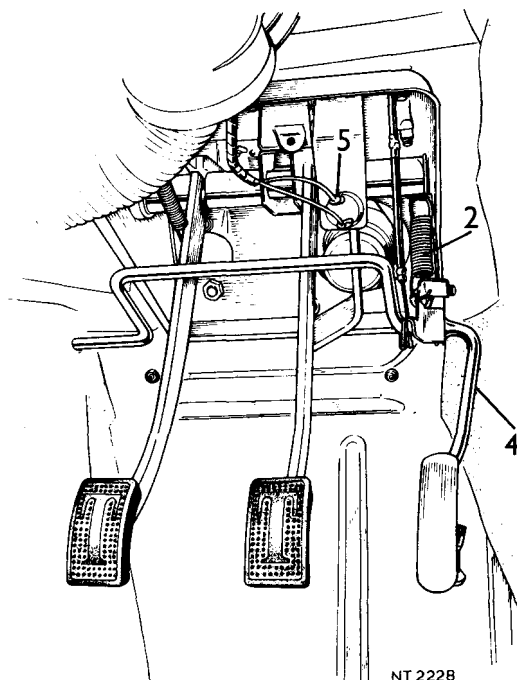

## BRAKES

### HANDBRAKE LEVER ASSEMBLY

– Remove and refit 70.35.08

#### Removing

1. Release the handbrake.
2. Disconnect the handbrake cables from the backplate lever.
3. Remove the carpet from the rear of the transmission tunnel.
4. Remove the bolt and nut securing the handbrake lever to the transmission tunnel.
5. Release the handbrake cables from the handbrake compensator linkage and withdraw the handbrake lever assembly from the transmission tunnel.

#### Refitting

6. Reverse instructions 1 to 5.

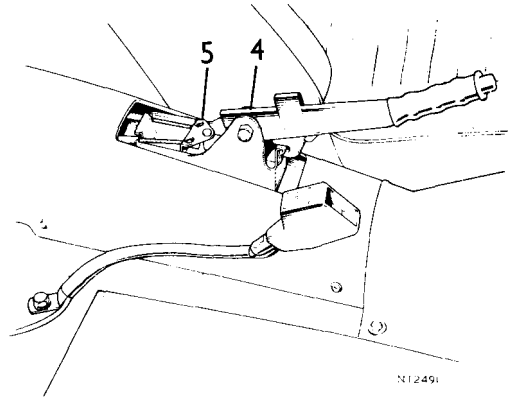

### HANDBRAKE CABLE

– Adjust 70.35.10

1. Jack up the rear wheels and release the handbrake.
2. Tighten the brake adjusters on the rear backplates until both wheels are locked.
3. Slacken the locknuts securing the brake cable forks to the brake cable.
4. Remove the clevis pins securing the brake cable forks to the backplate levers.
5. Adjust the cable forks until the clevis pins can just be engaged in the forks and backplate levers without force. Tighten the locknuts. Note adjustment should be made equally to the forks in order that the compensator is maintained in a central position.
6. Fit the clevis pins to the cable forks and backplate levers and secure with new split pins.
7. Slacken the brake adjusters until the wheels rotate freely.
8. Remove the jack.

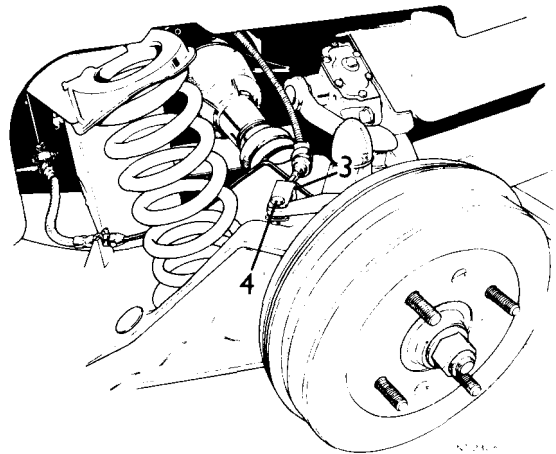

### HANDBRAKE COMPENSATOR

– Remove and refit 70.35.11

#### Removing

1. Remove the carpet from the rear of the transmission tunnel to expose the handbrake lever assembly.
2. Release the handbrake.
3. Remove the split pin, plain washer and clevis pin securing the compensator to the compensator link.
4. Release the handbrake cables and withdraw the compensator.

#### Refitting

5. Reverse instructions 1 to 4.

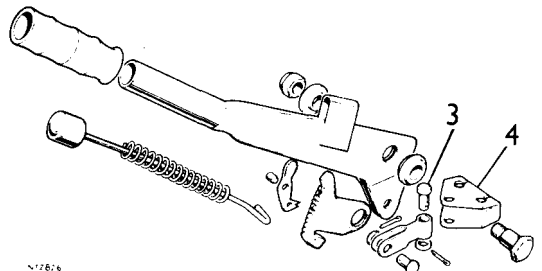

70.35.08  
70.35.11

## HANDBRAKE CABLE ASSEMBLIES – SET

## – Remove and refit

70.35.16

## Refitting

## Removing

1. Remove the carpet from the rear of the transmission tunnel to expose the handbrake lever assembly.
2. Release the handbrake.
3. Jack up the rear wheels and support the chassis on stands.
4. Remove the clevis pins securing the cable forks to the backplate levers.
5. Remove the nuts and spring washers securing the brake cable supports to the trailing arms.
6. Release the brake cables from the handbrake compensator
7. Remove the brake cables.

8. Fit the inner cables to the compensator and the outer casings to the trailing arms.
9. Tighten the brake adjusters on the rear backplates until the wheels are locked.
10. Adjust the brake cable forks equally until the clevis pins will just enter the forks and backplate levers without force.
11. Check that the compensator is central and if necessary readjust cable length by means of the cable forks.
12. Slacken the brake adjusters until the wheels rotate without brake drag.
13. Remove the stands and jack.
14. Fit the carpet to the rear of the transmission tunnel.

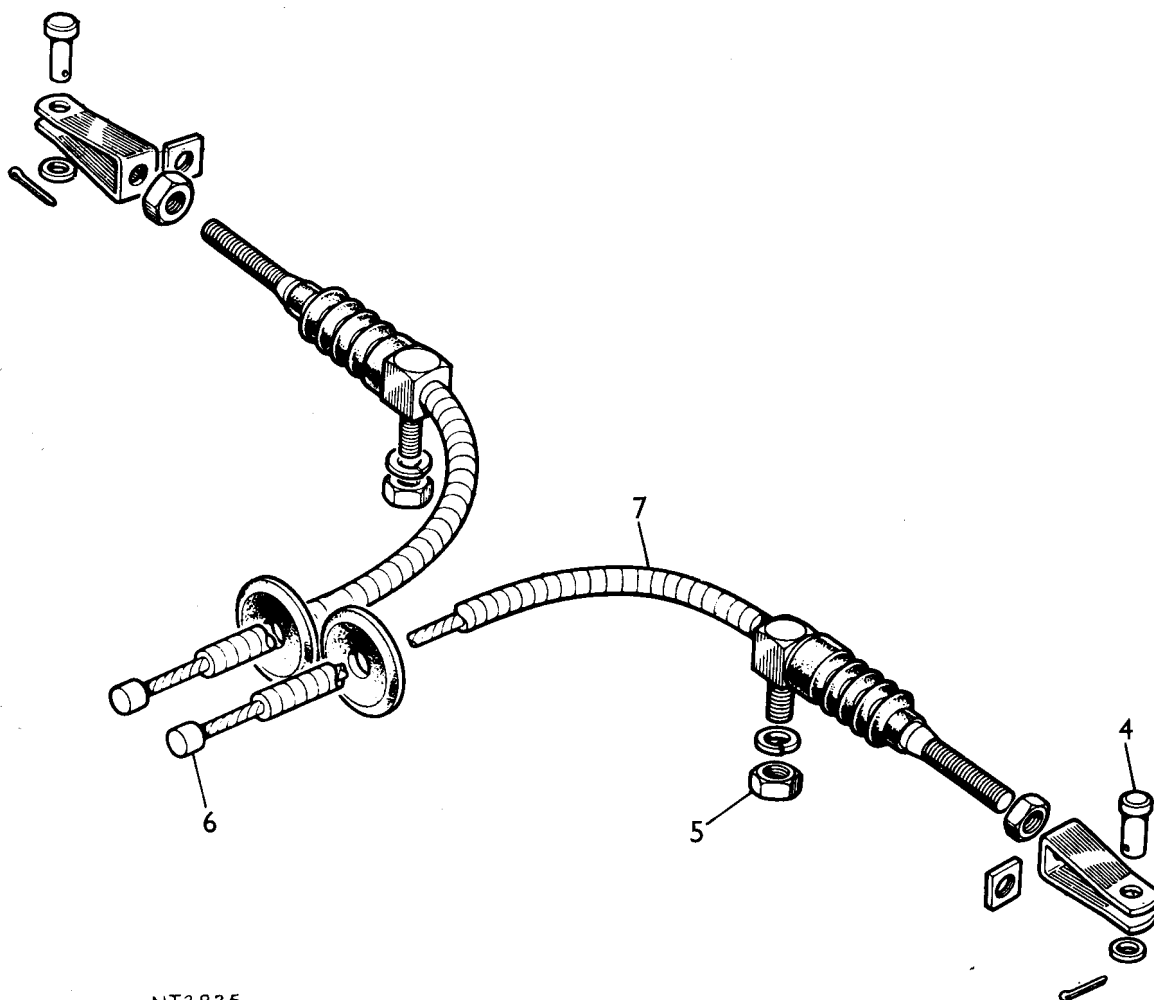

NT2825

## BRAKES

### FRONT BRAKE PADS

– Remove and refit

70.40.01

#### Removing

1. Jack up the car and remove the front wheels.
2. Withdraw the spring pins (2) from the brake pad retaining pins.
3. Withdraw the brake pad retaining pins (2).
4. Lift out the brake pads complete with damping shims.
5. Repeat instructions 2 to 4 on opposite front wheel.

#### Refitting

6. Ease the caliper pistons into the bores to provide clearance to accommodate new brake pads, if necessary. This operation can be facilitated by applying pressure to the piston and at the same time opening the bleed nipple. Close the nipple when the piston has moved the required amount and repeat on the opposite piston in caliper. Provided the piston is not allowed to retract while the nipple is open, subsequent bleeding is not usually necessary.
7. Remove dust and clean the brake pad locations in the caliper.
8. Fit the brake pads and damping shims to the caliper ensuring that the arrow on the damping shims points in the direction of the forward disc rotation.
9. Engage the pad retaining pins in the caliper and secure with the spring pins.
10. Repeat instructions 6 to 9 on opposite front wheel.
11. Fit the road wheels and remove the jack.
12. Apply and release the brakes.
13. Check the level of fluid in the reservoir.

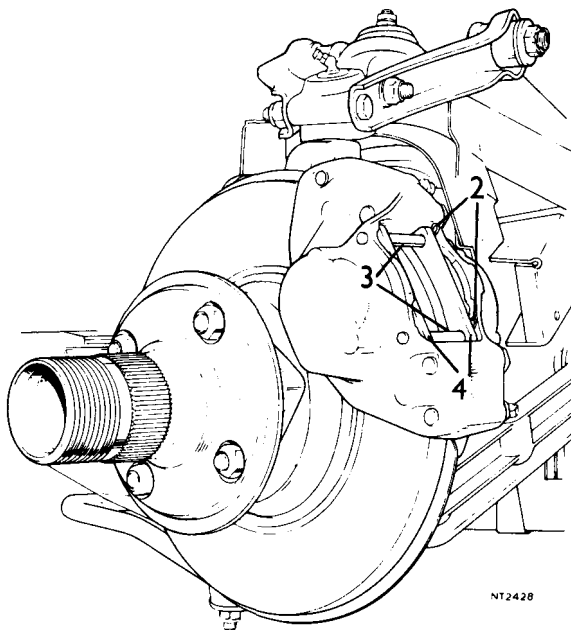

### REAR BRAKE SHOES

– Remove and refit

70.40.03

#### Removing

1. Jack up the car and remove the road wheel.
2. Release the handbrake.
3. Fully slacken off the brake adjuster.
4. Remove the hub extension (wire wheels only). Remove the brake drum.
5. Remove the shoe-steady pins and springs.
6. Release the leading shoe from the adjuster and wheel cylinder.
7. Release the trailing shoe from the adjuster and wheel cylinder.
8. Unhook the brake shoe return springs and remove the shoes and springs.

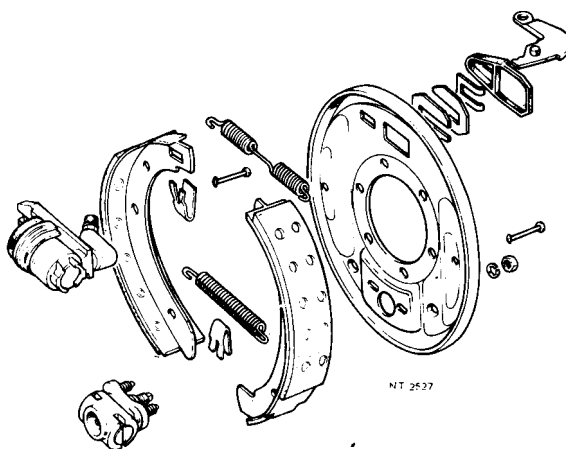

*Continued*

**Refitting**

9. Engage the hooks of the upper and lower return springs in the secondary brake shoe and offer up to the backplate. Do not fit the shoe to either the wheel cylinder or brake adjuster.
10. Engage return springs in the leading shoe.
11. Fit the leading shoe in position in the wheel cylinder and adjuster.
12. Fit the trailing shoe to the wheel cylinder and adjuster.
13. Check both return springs to ensure that hook ends are properly engaged in the shoes.
14. Fit the shoe-steady pins and springs. Note that the open end of the springs should lead in the direction of wheel rotation. See illustration for correct positions of brake shoes and shoe-steady springs.
15. Fit the brake drum. Fit the hub extension (wire wheels only).
16. Adjust the brake.
17. Fit the road wheel and remove the jack.

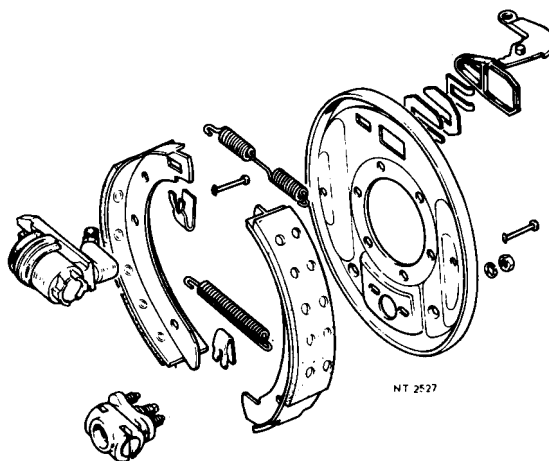

**REAR BRAKE ADJUSTER**

– Remove and refit

**70.40.17**

**Removing**

1. Jack up the car and remove the road wheel.
2. Release the handbrake and remove the brake drum and brake shoes 70.40.03.
3. Remove the two nuts and spring washers securing the adjuster to the backplate and withdraw the adjuster.

**Refitting**

4. Reverse instructions 1 to 3.

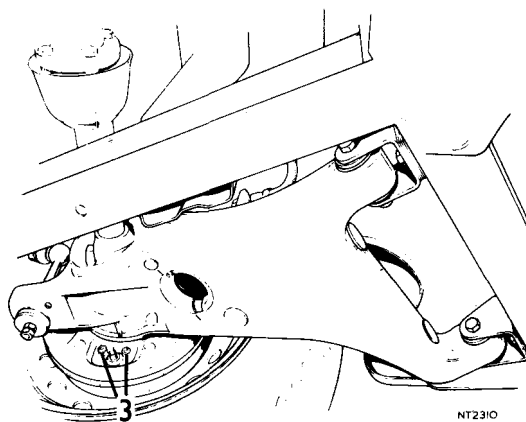

## SERVO

### – Remove and refit

70.50.01

#### Removing

1. Disconnect the vacuum hose from the non-return valve.
2. Disconnect the two brake pipes from the master cylinder.
3. Remove the two nuts and spring washers securing the master cylinder to the servo and withdraw the master cylinder.
4. Remove the clevis pin securing the servo push rod to the brake pedal.
5. Remove the four nuts and spring washers securing the servo to the pedal bracket. And withdraw the servo.

#### Refitting

6. Reverse instructions 1 to 5.
7. Bleed the brakes.

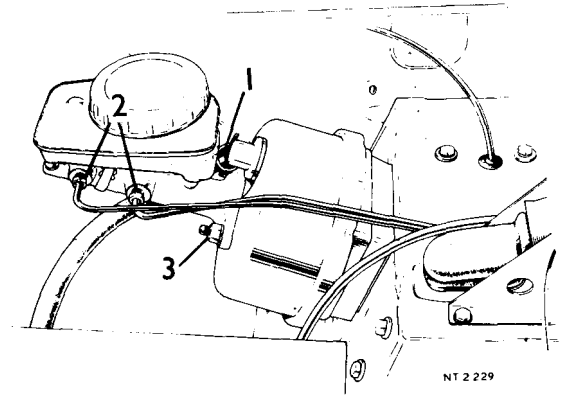

## SERVO FILTER

### – Remove and refit

70.50.25

#### Removing

1. Remove the brake stop switch.
2. Remove the split pin, plain washer and clevis pin securing the servo push rod to the brake pedal.
3. Remove the rubber boot from the push rod.
4. Withdraw the filter.

#### Refitting

5. Reverse instructions 1 to 4.

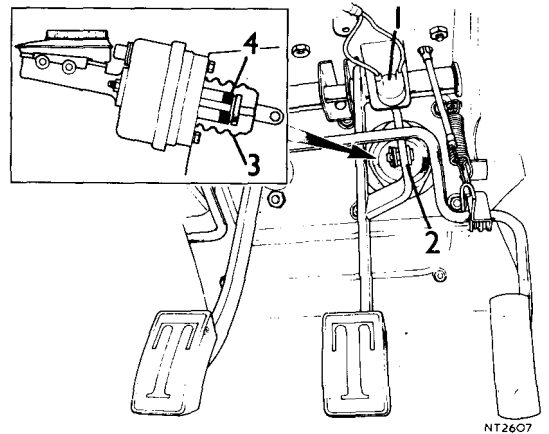

## FRONT CALIPER

## – Remove and refit

70.55.02

## Removing

1. Jack up the car and remove the front wheel.
2. Disconnect the front caliper brake pipe union at the flexible hose.
3. Remove the two bolts and spring washers securing the caliper to the mounting disc.
4. Withdraw the caliper.

## Refitting

5. Reverse instructions 2 to 4.
6. Bleed the brakes.

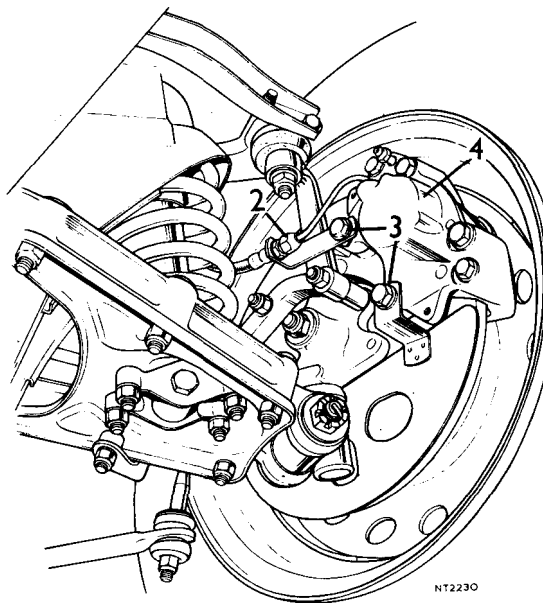

NT2230

## FRONT CALIPER

## – Renew seals

70.55.13

## Dismantling

1. Remove the caliper 70.55.02
2. Remove the brake pads and shims 70.40.01.
3. Remove the circlip retaining the piston dust covers and withdraw the dust covers.
4. Extract the caliper pistons. Piston removal may be effected using a low pressure air line. Do not interchange the pistons.
5. Prise out the cylinder seals taking care not to damage the cylinder bore.
6. Thoroughly clean the caliper and pistons.

## Reassembling

7. Carefully install new seals in the cylinder bores and lubricate the bores with clean brake fluid.
8. Fit the pistons to the caliper.
9. Fit new dust covers and circlips.
10. Fit the caliper to the car 70.55.02.
11. Fit the brake pads and shims 70.40.01.
12. Bleed the brakes.

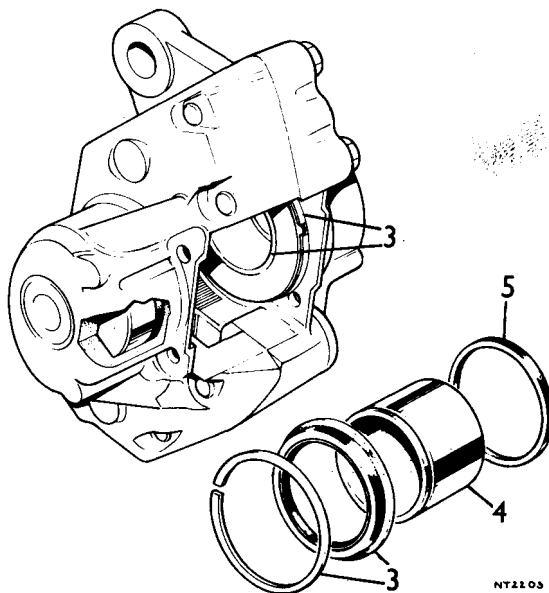

NT2203

## REAR WHEEL CYLINDER

– Remove and refit

70.60.18

### Removing

1. Remove the brake shoes 70.40.03.
2. Remove the clevis pin securing the backplate lever to the handbrake cable.
3. Disconnect the brake fluid pipe from the rear wheel cylinder.
4. Remove the outer plate (distance washer) in a forward direction.
5. Remove the locking plate in a rearward direction.
6. Remove the spring plate in a forward direction.
7. Remove the rubber boot at the rear of the backplate.
8. Withdraw the wheel cylinder and lever assembly from the front of the backplate.

### Refitting

9. Enter the wheel cylinder and lever assembly in the backplate.
10. Fit the rubber boot to the wheel cylinder at the rear of the backplate.
11. Fit the spring plate entering it in the slot in the wheel cylinder housing from the forward direction ensuring that the angled ends are inclined away from the backplate.
12. Fit the locking plate from the rear of the wheel cylinder ensuring that the slots in the rear face of the clip engages the angled tips of the spring plate.
13. Fit the outer plate (distance washer) from the forward direction.
14. Connect the brake pipes to the wheel cylinder.
15. Connect the handbrake cable to the wheel cylinder lever, and secure the clevis pin with a new split pin.
16. Fit the brake shoes, brake drum and road wheel.
17. Remove the jack.
18. Bleed the brakes.

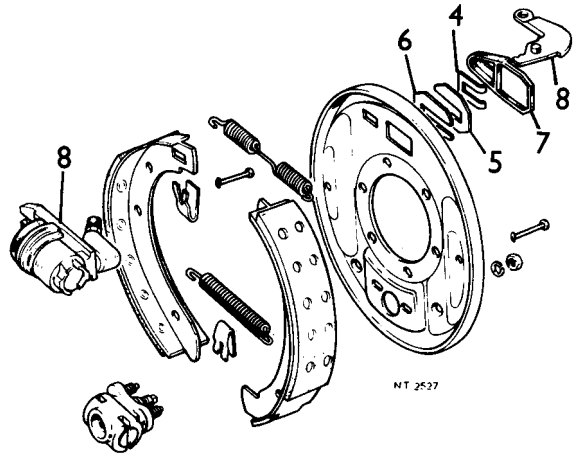



## REAR WHEEL CYLINDER

– Overhaul

70.60.26

1. Jack up the car and remove the rear road wheel.
2. Remove the hub extension (wire wheels only). Remove the brake drum.
3. Remove the brake shoes.
4. Disconnect the handbrake cable from the backplate lever.
5. Remove the clip securing the rubber boot to the wheel cylinder.
6. Withdraw the rubber boot.
7. Withdraw the piston complete with seal from the wheel cylinder.
8. Examine the piston and cylinder bore for scoring, wear or damage. If either are damaged or worn or doubt exists, the cylinder assembly must be renewed.
9. Remove the seal from the piston.
10. Fit a new seal to the piston ensuring that the seal lip faces towards the closed end of the cylinder.
11. Fit the rubber boot to the piston, smear the piston and cylinder with clean brake fluid and insert the piston into the cylinder.
12. Ensure the rubber boot is fitted snugly to the cylinder and secure with the clip.
13. Fit the brake shoes, brake drum and hub extension if applicable.
14. Connect the handbrake cable to the backplate lever.
15. Fit the road wheel and remove the jack.
16. Bleed the brakes.

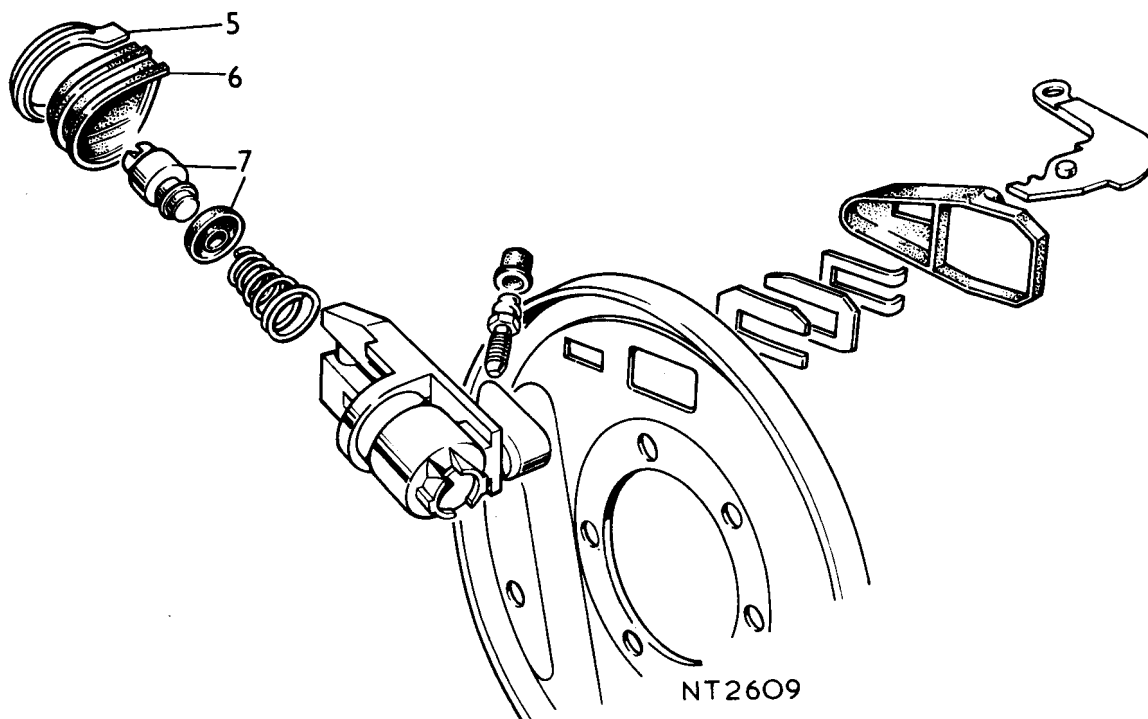

**WHEEL AND TYRE OPERATIONS**

Tyres – general . . . . .	74.10.00
Wheel and tyre balance . . . . .	74.15.00
Wheels – remove and refit . . . . .	74.20.00
Wheels – wire . . . . .	74.20.01



Type	Size	Pressures			
		Front		Rear	
		lb/in <sup>2</sup>	kg/cm <sup>2</sup>	lb/in <sup>2</sup>	kg/cm <sup>2</sup>
Radial ply – Tubeless  Tubes are fitted to wire wheels	** 165HR – 15 All Conditions High Speed	22	1.5	26	1.8
	185SR – 15 All Conditions	28	1.9	32	2.2
		20	1.4	24	1.6

\*\*

Tyres of the correct type and dimensions at the correct cold inflation pressures are an integral part of the vehicle's design, therefore regular maintenance of tyres contributes not only to safety but to the designed functioning of the vehicle. Road holding, steering and braking are impaired by incorrectly pressurised, badly fitted, and worn tyres.

Tyres of the same size and type but of different make may have widely varying characteristics. It is therefore recommended that tyres of the same make and type are fitted to all wheels.

Radial tyres are fitted as original equipment. It is both dangerous and in the U.K. illegal to use on the public roads a vehicle fitted with unsuitable combinations of tyres. The following recommendations should therefore be observed.

1. Do not mix radial-ply and cross-ply tyres on the same axle.
2. Do not fit radial-ply tyres to the front wheels and cross-ply tyres to the rear wheels.
3. With suitable tyre pressure adjustments it may be possible to obtain acceptable handling with cross-ply tyres on the front wheels and radial-ply tyres on the rear wheels, but this combination is not recommended.

**Tyre pressures**

The tyre pressures recommended (refer chart), provide optimum ride and handling characteristics for all normal conditions. Tyre pressures should be checked and if necessary, adjusted weekly. This should be done with the tyres cold, i.e. not immediately following a run as pressures and temperatures increase when running. 'Bleeding' a warm tyre to the recommended pressure will result in under inflation which may be dangerous as well as harmful to the tyre. Pressure loss, with time, is normal, but if a pressure drop exceeds 2 lb/in<sup>2</sup> (0.14 kg/cm<sup>2</sup>) in a period of one week, investigation should be made. In the U.K. it is an offence to use a vehicle with tyres improperly inflated.

The spare wheel tyre should be maintained at rear tyre pressure and adjusted if fitted to the front of the car.

**Wear**

All tyres, fitted as original equipment, incorporate wear indicators in the tread pattern. When the tread has worn to a remaining depth of approximately 1.5 mm the wear indicators are exposed as bars which connect the tread pattern across the width of the tread. In the U.K. and some other countries it is illegal to use tyres when the tread is worn to a depth of less than 1 mm.

The properties of many tyres alter progressively with wear, particularly with regard to 'wet grip' and aquaplaning resistance, which are gradually but substantially reduced. Extra care and speed restriction should therefore be exercised on wet roads as the effective tread depth diminishes.

Tyre wear is influenced by driving techniques, incorrect inflation, types of road surface and also by misalignment and mechanical defects. Investigations into tyre wear must therefore consider a variety of factors.

*Continued*

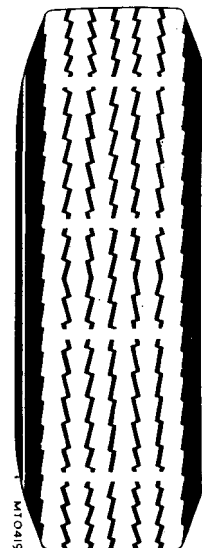

# WHEELS AND TYRES

## Damage

Excessive localised distortion such as is sometimes caused by severe contact with kerbs or stones can cause the tyre casing to fracture and may lead to premature tyre failure. Tyres should be periodically examined for cracks and cuts, exposed cords etc., and all imbedded objects such as stones and glass, removed from the treads. Oil or grease on the rubber should not be allowed to remain but should be removed by the sparing use of fuel. Do not use kerosene which has a detrimental affect on rubber.

## Heat

When paint respraying is carried out and the car is subjected to a drying or baking oven it is recommended that the wheels be removed or at least that the weight of the car is relieved from the tyres.

## Repairs – Tyres

A temporary repair can be made to tubeless tyres using a special kit, provided that the puncturing hole is small and is confined to the central tread area. The following precautions must be observed:

1. Use only one plug in each hole.
2. Following a temporary repair do not use the car at high speeds.
3. Remove the tyres from the wheel and make an internal, proper repair at the earliest opportunity.

## Repairs – Tubes

A vulcanised repair must be made.

## Winter tyres

Winter tyres are designed to provide improved traction and braking in mud and snow. Their performance on hard surfaces may, however, be inferior to normal road tyres and extra care is therefore required when using them under normal conditions. The tyre manufacturers recommendations regarding speed restrictions must be observed.

## Racing and competition tyres

Should the vehicle be tuned to increase its maximum speed or be used for racing or competition work, consult the respective tyre company regarding the need for and use of tyres of special, or racing construction. Racing tyres are not recommended for normal road use.

## Valves

When a new tubeless tyre is fitted the snap-in type valve housing should also be renewed. To facilitate fitting, lubricate the valve housing with a soap solution and use a special tool to enter the housing squarely into an airtight position in the wheel rim.

## WHEELS AND TYRE BALANCE

74.15.00

The balancing of wheel and tyre assemblies is necessary to eliminate the undesirable and unpleasant effects of vibration which can be induced by the rotation of out-of-balance forces.

Balancing is advised when a tyre is renewed or if a tyre is removed for repair and refitted.

## WHEELS

### Wire Wheels

74.20.00

It is recommended that the servicing and reconditioning of wire wheels is entrusted only to those who are equipped to fulfil this specialist function. It is pointed out that the renewal of a single spoke may necessitate extensive readjustment to spoke tension throughout the wheel.

The average spoke torque in both rows should not be less than 60 lbf/in (0.69 kgf/m). With spokes fully tightened the nipples must not be at the extremities of the fitted flush with the nipple. \*\*P.V.C. tape may be wrapped round the wheel over the nipple heads to give added protection for the tyre inner tube.\*\*

*Continued*

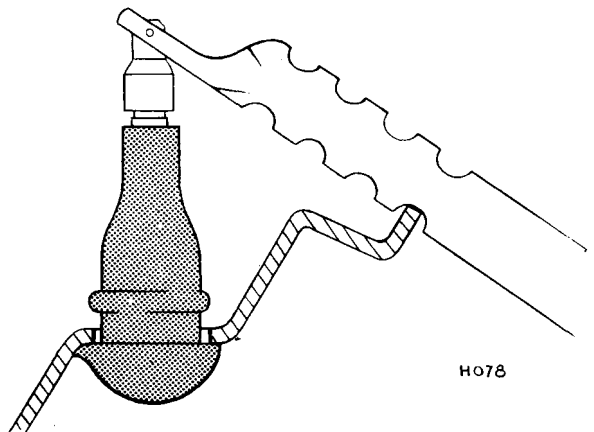

WHEEL TOLERANCES

Wire Wheels

Wobble

Lateral variation measured on the vertical inside face of the rim should not exceed 0.050 in (1.27 mm).

Eccentricity

On a truly mounted and revolving wheel the difference between the high and low points measured on either rim ledge should not exceed 0.050 in (1.27 mm).

Disc Wheel

Wobble

Lateral variation measured on the vertical inside face of the rim should not exceed 0.045 in (1.143 mm).

Eccentricity

On a truly mounted and revolving wheel the difference between the high and low points measured on either rim ledge should not exceed 0.045 in (1.143 mm).

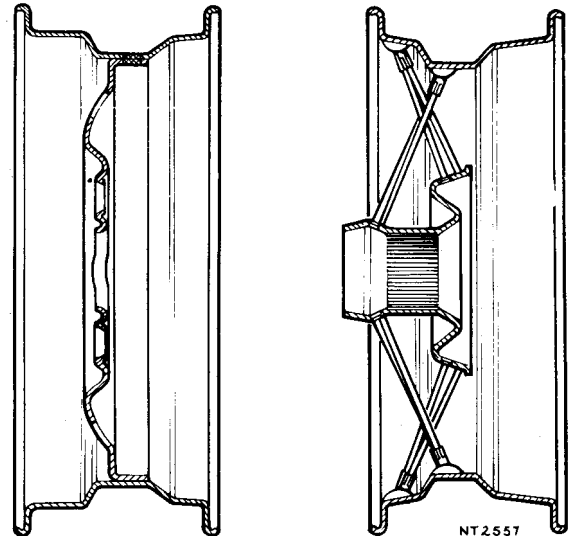

WHEELS

– Remove and refit

74.20.01

Pressed steel wheels

5½J rims. Wheels are located and retained on the hubs by four 7/16 UNF studs and chrome-plated dome nuts tightened to 60 to 80 lbf/ft (8.3 to 11.1 kgf/m). Embellishment is provided by spring-loaded plastic hub covers fitted under the dome nuts.

Wire wheels

5½J rims, with 48 inner and 24 outer spokes. Wheel hub extensions are fitted. The wheels are splined to the hub extensions and are retained by a conical seating quick release type nut. The hub extensions and quick release nuts are screwed with right hand threads on the L.H. side of the car and with left hand threads on the R.H. side of the car. The quick release wheel retaining nuts are therefore *tightened* when rotated against the direction of forward wheel rotation, and *slackened* when rotated in the direction of forward wheel rotation. Hub extensions must not be interchanged left to right or vice versa.

When fitting the wire wheels to the car it is important to ensure that the conical seats on the hub extensions, road wheel, and retaining nuts are free of grit. Conical faces and splines must be coated with a P.B.C. (Poly Butyl Cuprasyl) base or an equivalent high temperature, low friction lubricant. It is necessary to ensure that wire wheels are fully tightened *before* lowering the wheel to the ground.

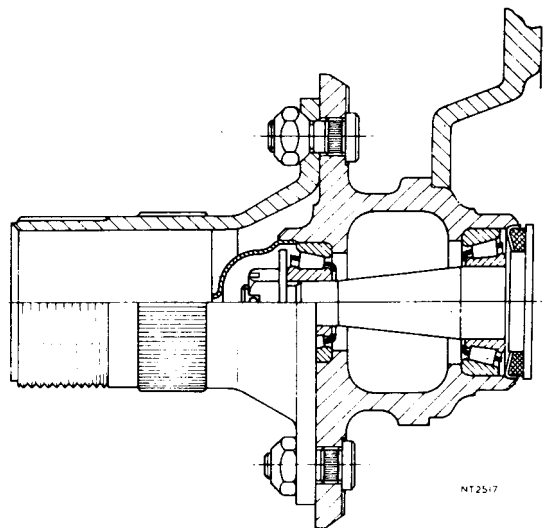

**BODY OPERATIONS**

Ashtray – front – remove and refit . . . . .	76.67.13
Air intake vent – remove and refit . . . . .	76.15.17
Bonnet – adjust . . . . .	76.16.02
Bonnet – remove and refit . . . . .	76.16.01
Bonnet catch – remove and refit . . . . .	76.16.34
Bonnet hinges – adjust . . . . .	76.16.20
– remove and refit . . . . .	76.16.12
Bonnet lock – remove and refit . . . . .	76.16.21
Bonnet release cable – remove and refit . . . . .	76.16.29
Bonnet stay – remove and refit . . . . .	76.16.14
Bumper – front – remove and refit . . . . .	76.22.08
** Override – Remove and refit . . . . .	76.22.01 **
Bumper – rear – remove and refit . . . . .	76.22.15
** Override – Remove and refit . . . . .	76.22.02 **
Carpet – floor – front – remove and refit . . . . .	76.49.02
Carpet – floor – rear – remove and refit . . . . .	76.49.03
Carpet – heelboard and seat pad – remove and refit . . . . .	76.49.07
Carpet – gearbox cover – front – remove and refit . . . . .	76.49.01
Carpet – gearbox cover – rear – remove and refit . . . . .	76.49.05
Carpet – transmission tunnel – remove and refit . . . . .	76.49.06
Chassis frame – alignment check . . . . .	76.10.02
Control cowl – remove and refit . . . . .	76.25.03
Crossmember – front (tubular) – remove and refit . . . . .	76.10.05
Door check strap – remove and refit . . . . .	76.40.27

*continued*



**BODY OPERATIONS — *continued***

Door — remove and refit . . . . .	76.28.01
Door glass — remove and refit . . . . .	76.31.01
Door glass regulator — remove and refit . . . . .	76.31.45
Door handle — remove and refit . . . . .	76.58.01
Door hinges — remove and refit . . . . .	76.28.42
Door lock — remove and refit . . . . .	76.37.12
Door lock remote control — remove and refit . . . . .	76.37.31
Door lock striker — remove and refit . . . . .	76.37.23
Door seal — remove and refit . . . . .	76.40.01
Door trim pad — remove and refit . . . . .	76.34.01
Fascia — metal — remove and refit . . . . .	76.46.10
Fascia — veneered — remove and refit . . . . .	76.46.01
Fascia crash pad — upper — remove and refit . . . . .	76.46.04
— lower — remove and refit . . . . .	76.46.12
Fascia support bracket — remove and refit . . . . .	76.46.09
Gearbox tunnel cover trim pad — remove and refit . . . . .	76.13.06
Gearbox tunnel cover — remove and refit . . . . .	76.25.07
Glovebox — remove and refit . . . . .	76.52.03
Glovebox lid assembly — remove and refit . . . . .	76.52.02
Glovebox lock — remove and refit . . . . .	76.52.08
Grille — front — remove and refit . . . . .	76.55.03

*Continued*



**BODY OPERATIONS — continued**

Hardtop — remove and refit . . . . .	76.61.01
Hood assembly — remove and refit . . . . .	76.61.08
Luggage compartment lid — remove and refit . . . . .	76.19.01
Luggage compartment lid hinges — remove and refit . . . . .	76.19.07
Luggage compartment lid lock — remove and refit . . . . .	76.19.11
Luggage compartment lid lock striker — remove and refit . . . . .	76.19.12
Luggage compartment lid seal — remove and refit . . . . .	76.19.06
Luggage compartment trim pad — remove and refit . . . . .	76.13.17
Private lock — remove and refit . . . . .	76.37.39
Rear compartment trim pad — remove and refit . . . . .	76.13.20
Seat belt — static — remove and refit . . . . .	76.73.02
Seat belt — automatic — remove and refit . . . . .	76.73.10
Seat cushion cover — remove and refit . . . . .	76.70.02
Seat — driver — remove and refit . . . . .	76.70.04
Seat — passenger — remove and refit . . . . .	76.70.05
Seat runners — remove and refit . . . . .	76.70.21
Seat squab catch — remove and refit . . . . .	76.70.27
Seat squab cover — remove and refit . . . . .	76.70.03
Valance — air intake — remove and refit . . . . .	76.79.04
— spoiler — remove and refit . . . . .	76.10.46 **
Windscreen — glass — remove and refit . . . . .	76.81.01
— frame assembly — remove and refit . . . . .	76.81.02





## CHASSIS FRAME

## – Alignment check

76.10.02

Whilst severe damage to the chassis is readily detected, less serious damage may cause distortion, that is not visually apparent. If steering and suspension checks indicate a fault which cannot be attributed to anything other than chassis distortion, the chassis frame should be checked for twist and squareness. Reference should be made to the appropriate sections of the manual where component removal is necessary for access to checking points.

## Checking for twist

1. Position the vehicle on a clean level floor.
2. Place a jack under each jacking point and remove the road wheels 74.20.01.
3. Adjust the jacks until the following conditions are achieved:-

Points 'A' are 24.97 in (63.40 cm) above the floor.

Points 'F' are 24.94 in (63.35 cm) above the floor.

This condition sets the datum 20 in (50.8 cm) above the floor.

If the height of points 'A' cannot be equalised, the difference in height of points 'A' indicates the amount by which the chassis is twisted.

## Checking for squareness

4. Transfer all the lettered points shown to the floor, using a plumb-bob and fine cord.
5. Letter the points on the floor and connect each pair by drawing a line between them.
6. Mark the central point of each line and place a straight edge along these mid points.
7. Check for squareness.
8. Using a straight edge mark the diagonals as shown.
9. Check for squareness. If the chassis is square then each pair of opposite diagonals must be equal in length and the points of intersection must lie on the same straight line.
10. The extent of lateral chassis distortion is assessed by the amount and direction by which any central point on the transverse line and/or the point of intersection of any pair of diagonals deviates from the centre line.

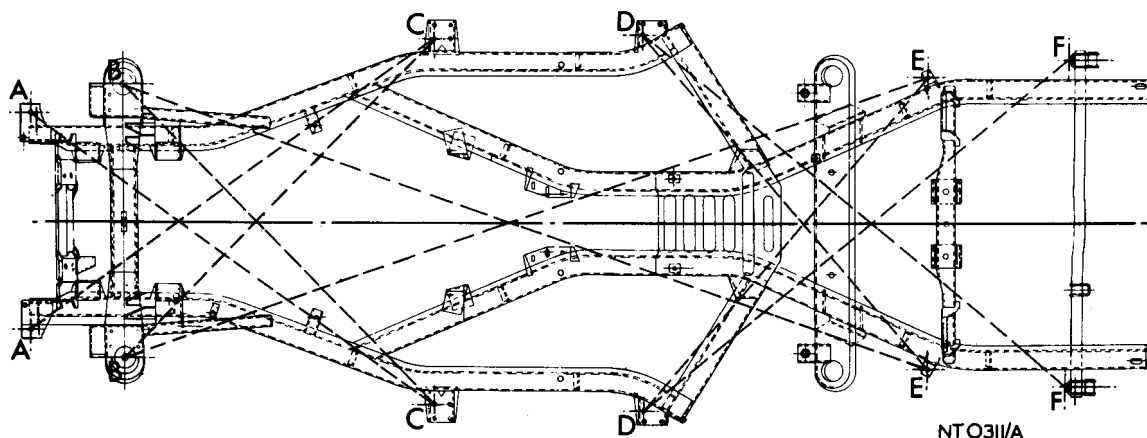

NTO311/A

# BODY

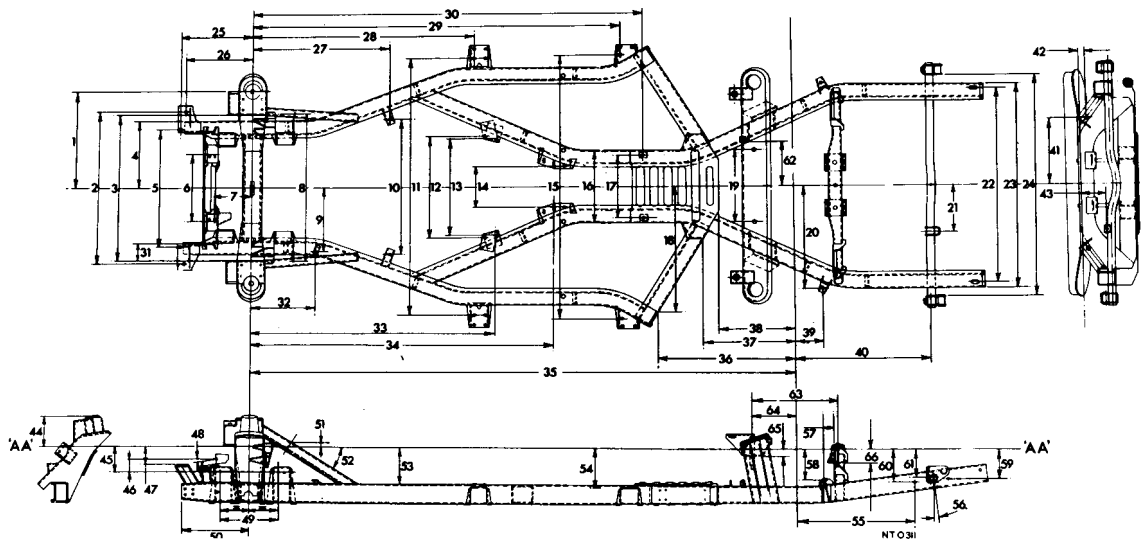

A A Datum line

	Inches	Centimetres		Inches	Centimetres		Inches	Centimetres
1	15.04	38.2	25	11.91	30.2	45	4.28	10.9
2	25.31	64.3	**	11.79	30.0		4.22	10.7
	25.19	63.9	26	11.06 **	28.1	46	2.03	5.2
3	24.03	61.0		10.94	27.8		1.97	5.0
	23.97	60.9	27	22.56	57.3	47	3.25	8.2
4	11.06	28.1		22.44	56.9		3.13	7.9
	10.94	27.8	28	36.25	92.1	48	5°	
5	19.56	49.7		36.13	91.8	49	9.53	24.2
	19.44	49.4	29	60.06	152.4		9.47	24.0
6	11.06	28.1		59.94	152.3	50	11.19	28.4
	11.00	27.9	30	63.63	161.8		11.06	28.2
7	** 5.53	14.0		63.50	161.4	51	0.69	1.8
	5.47	13.9 **	31	3.39	7.6		0.56	1.4
8	24.44	62.1	**	3.33 **	7.5	52	32°7'	
	24.31	61.7	32	10.69	27.1	53	6.06	15.4
9	10.56	26.8		10.56	26.8	54	6.53	16.6
	10.44	26.5	33	39.59	100.5		6.47	16.4
10	22.31	56.7		39.53	100.3	55	18.75	49.2
	22.19	56.4	34	**43.91	111.5} †	56	8°	
11	42.31	107.5		43.85	111.4} †	57	1.70	4.3
	42.19	107.2		48.88	124.1} †† **		1.64	4.2
12	16.71	42.4		48.82	124.0} †† **	58	5.25	13.3
	16.65	42.3	35	88.13	223.9		5.13	13.0
13	15.91	40.4		87.88	221.5	59	4.94	12.6
	15.85	40.3	36	21.92	55.7		4.81	12.4
14	** 7.81	19.8} †		21.87	55.5	60	5.38	13.7
	7.69	19.5} †	37	14.71	37.3			
	6.56	16.6} †		14.65	37.2	61	4.75	12.1
	6.44	16.3} ** ††	38	12.31	31.2	62	7.44	18.9
15	43.14	109.6		12.19	30.9		7.31	18.6
	43.02	109.3	39	4.38	11.1	63	13.23	33.6
16	11.94	30.3		4.25	10.8		13.17	33.4
	11.81	30.0	40	21.81	55.4	64	6.76	17.2
17	10.31	26.2		21.69	55.0		6.70	17.0
	10.19	26.0	41	10.72	27.2	65	1.34	3.4
18	20.36	51.7		10.66	27.0		1.28	3.3
	20.30	51.6	42	1.00	2.5	66	2.22	5.6
19	10.50	26.7		0.94	2.4		2.16	5.5
20	16.13	41.0	43	4.00	10.2			
	16.00	40.6		3.88	9.8			
21	10.62	27.0	44	4.97	12.6			
22	31.81	80.8						
	31.69	80.4						
23	33.50	85.1						
24	38.06	96.9						
	37.94	96.8						

† Two hole bracket up to Commission No. CF1 - Dimn., to centre line of forward hole.

†† Three hole bracket from Commission No. CF1 - Dimn., 34 to centre line of middle slot.

**FRONT CROSS MEMBER (TUBULAR)**

– Remove and refit **76.10.05**

**Removing**

1. Relieve the load on the cross member using a jack positioned beneath the chassis frame.
2. Slacken the two nuts securing the support bracket to the radiator.
3. Remove the two nuts and bolts securing the support brackets to the cross member.
4. Remove the nut and bolt securing the air cleaner bracket to the support bracket.
5. Remove the six bolts securing the cross member to the chassis frame.
6. Pull the support brackets clear and remove the cross member from the vehicle.

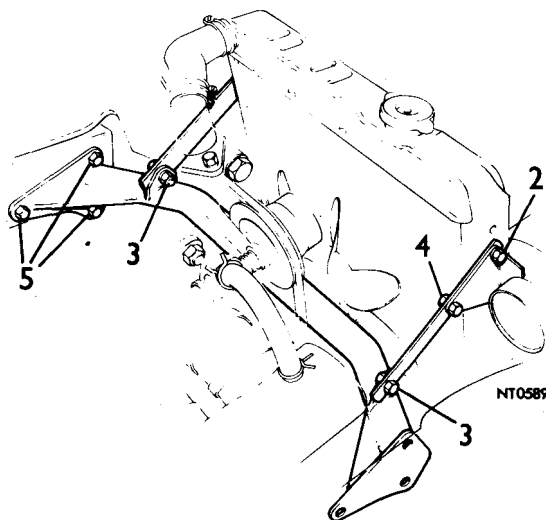

**Refitting**

7. Reverse instructions 1 to 6.

**FRONT VALANCE SPOILER**

– Remove and refit **76.10.46**

\*\* The spoiler fitted to later models is secured to the body by five bolts with plain washers and nuts. Note the location of the washers when removing the spoiler. \*\*

**GEARBOX TUNNEL COVER TRIM PAD**

– Remove and refit **76.13.06**

**Removing**

1. Remove the screw and cup washer securing the front end of the trim pad to the gearbox tunnel cover.
2. Disengage the rear end of the trim pad from the fascia support bracket. Lift off the trim pad.

**Refitting**

3. Reverse instructions 1 and 2.

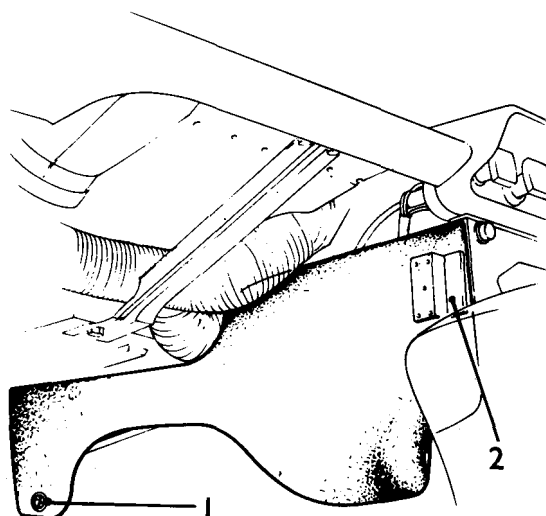

## BODY

### LUGGAGE COMPARTMENT TRIM PAD

– Remove and refit 76.13.17

#### Removing

1. Remove the luggage compartment carpet and floor.
2. Remove the luggage compartment lamp 86.45.16.
3. Remove the eight screws and washers securing the trim pad to the body. Lift out the trim pad.

#### Refitting

4. Reverse instructions 1 to 3.

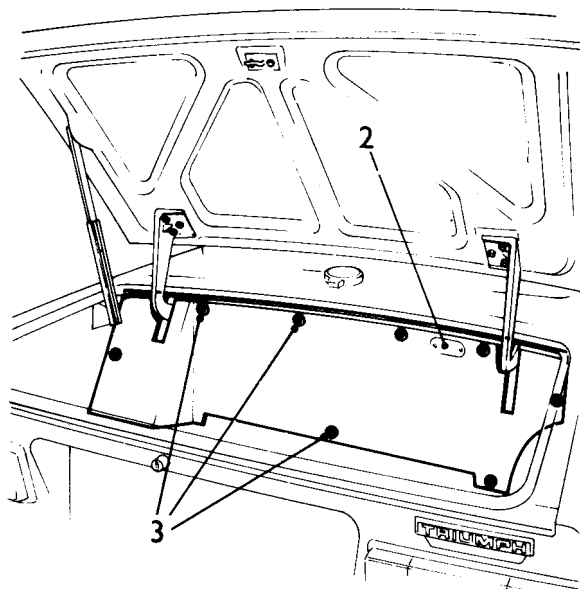

NT2591

### REAR COMPARTMENT TRIM PAD

– Remove and refit 76.13.20

The rear compartment trim pad is secured to the body by eleven screws and cup washers.

### AIR INTAKE VENT

– Remove and refit 76.15.17

(Vehicles with hinged vent)

#### Removing

1. Remove the spring nut and detach the control rod from the lid.
2. Disconnect both ends of the spring from the lid.
3. Remove the three bolts and lockwashers securing the lid to the scuttle.
4. Lift off the lid.

#### Refitting

5. Reverse instructions 1 to 4.

### AIR INTAKE VENT

– Remove and refit 76.15.17

(Vehicles with fixed vent)

The air intake vent is secured to the scuttle by two screws.

76.13.17  
76.15.17

**BONNET**

– Remove and refit

76.16.01

**Removing**

1. Raise and support the bonnet.
2. Remove the nut and washer securing the support stay to the bonnet.
3. Remove the eight bolts and washers securing the bonnet to the hinges.
4. Lift off the bonnet.

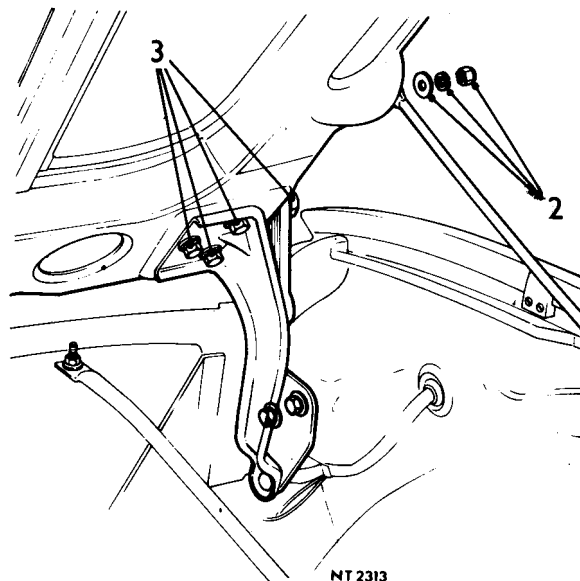

**Refitting**

5. Reverse instructions 1 to 4.

**BONNET**

– Adjust

76.16.02

1. Slacken the eight bolts securing the hinges to the bonnet.
2. Adjust the bonnet fore and aft as required.
3. Retighten the bolts.
4. Slacken the four bolts securing the hinges to the wing valances.
5. Adjust the bonnet front upwards or downwards as required.
6. Retighten the bolts.
7. Slacken the two locknuts and screw the rubber buffers in or out to obtain correct height adjustment.
8. Retighten the locknuts.

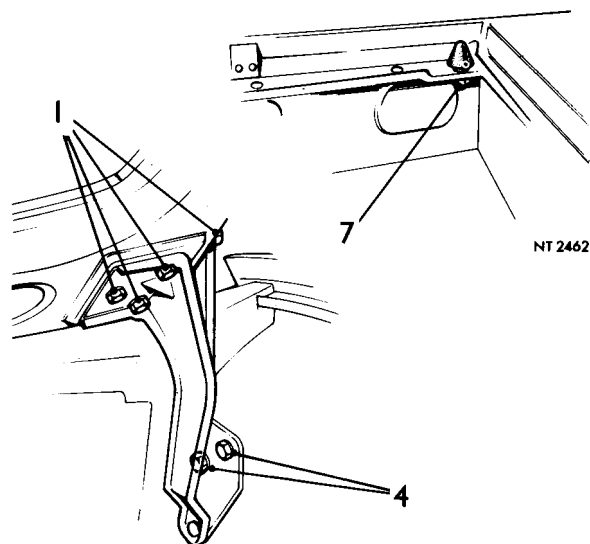

**BONNET HINGES**

– Remove and refit

76.16.12

**Removing**

1. Remove the bonnet 76.16.01
2. Remove the two bolts and washers and lift off the hinges.

**Refitting**

3. Reverse instructions 1 and 2.

# BODY

## BONNET STAY

– Remove and refit

76.16.14

### Removing

1. Raise and support the bonnet.
2. Remove the nut, plain washers and spring washer.
3. Detach the bonnet stay.

### Refitting

4. Reverse instructions 1 to 3.

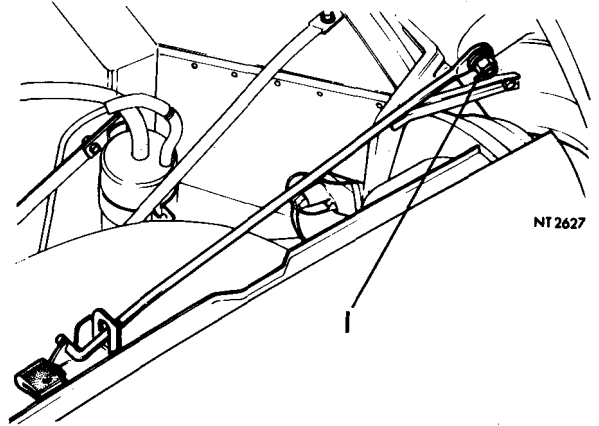

## BONNET CATCH

– Adjust

76.16.20

To ensure positive locking and eliminate free movement at the closing face, adjust the bonnet catch as follows:-

1. Pull back the spring and slacken the locknut at the base of the shaft.
2. Using a screwdriver, screw the shaft in or out as required.
3. Retighten the locknut.
4. Check the bonnet closing action and repeat instructions 1 to 3 if necessary.

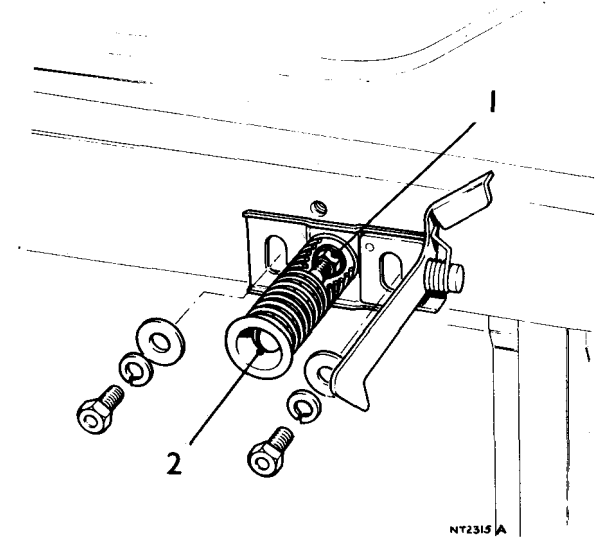

## BONNET LOCK

– Remove and refit

76.16.21

### Removing

1. Slacken the trunnion bolts and detach the release cable.
2. Remove the four bolts and washers securing the lock to the bulkhead.

### Refitting

3. Reverse instructions 1 and 2.

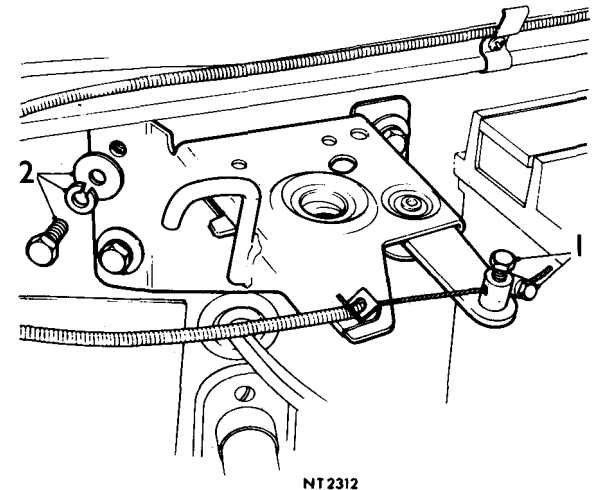

**BONNET RELEASE CABLE**

– Remove and refit

**76.16.29**

**Removing**

1. Slacken the trunnion bolts.
2. Pull the cable and clip from the lock.
3. Unscrew the nut.
4. Pull the cable out.

**CAUTION:** Do not close the bonnet whilst the cable is removed or loose.

**Refitting**

5. Reverse instructions 1 to 4.

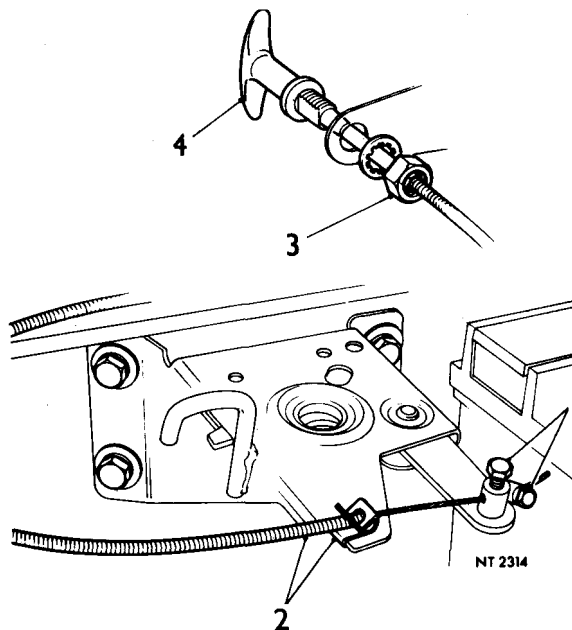

**BONNET CATCH**

– Remove and refit

**76.16.34**

**Removing**

1. Remove the two bolts and washers securing the catch to the bonnet.

**Refitting**

2. Refit in reverse order and adjust if necessary 76.16.20.

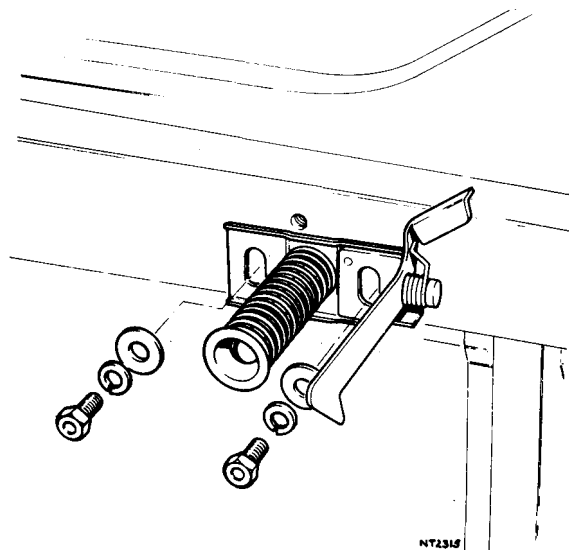

## BODY

### LUGGAGE COMPARTMENT LID

– Remove and refit 76.19.01

#### Removing

1. Raise and support the lid.
2. Remove the bolt and washers securing the support stay to the lid.
3. Remove the six bolts and washers securing the hinges to the lid and lift off the lid.

#### Refitting

4. Reverse instructions 1 to 3.

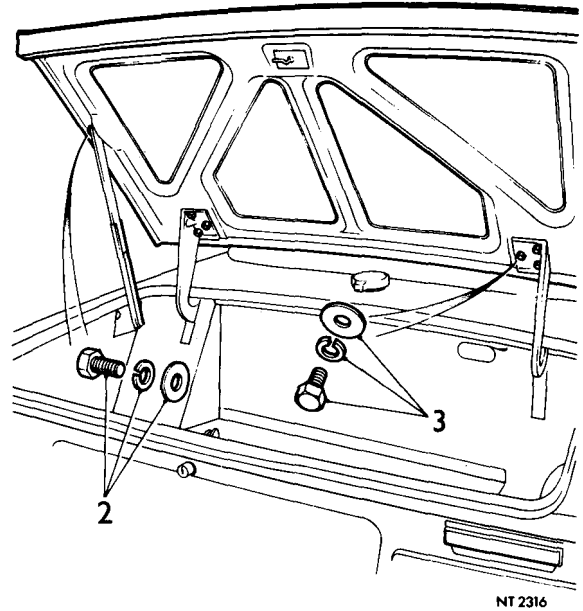

### LUGGAGE COMPARTMENT LID SEAL

– Remove and refit 76.19.06

#### Removing

1. Free the seal from the body, using a suitable blunt tool if necessary.

#### Refitting

2. Ensure mating surfaces of seal and body are clean.
3. Fit seal, using Seelastik SR51.

### LUGGAGE COMPARTMENT LID HINGES

– Remove and refit 76.19.07

#### Removing

1. Remove the luggage compartment trim pad. 76.13.17
2. Remove the luggage compartment lid 76.19.01.
3. Remove the four bolts and washers securing the hinges to the body.

#### Refitting

4. Reverse instructions 1 to 3, ensuring correct alignment of the lid.

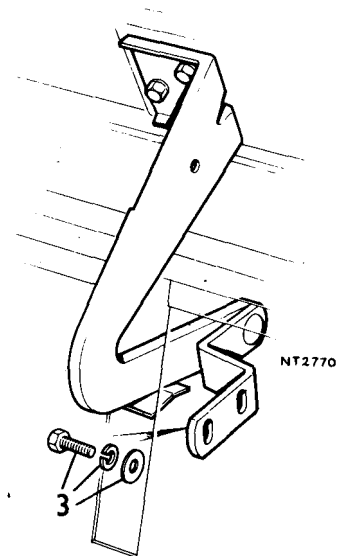



**LUGGAGE COMPARTMENT LID LOCK**

– Remove and refit

76.19.11

**Removing**

1. Remove the four screws and washers securing the lock to the body.
2. Manoeuvre the lock clear of the body.
3. Drill out the two 1/8 in (3.17 mm) rivets securing the lock catch to the push button mounting plate.
4. Remove the two screws and washers securing the push button sub assembly to the mounting plate.
5. Extract the circlip and remove the retainer, spring and body.
6. Drive out the pin and withdraw the locking device.

**Refitting**

7. Reverse instructions 1 to 6.

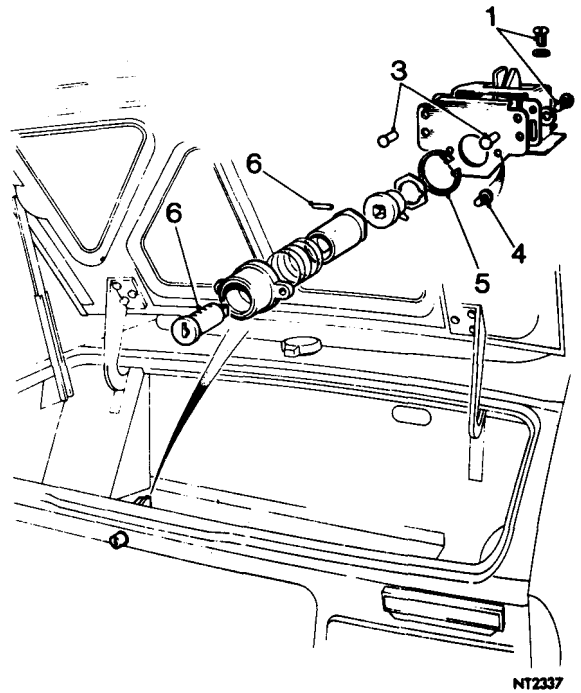

**LUGGAGE COMPARTMENT LOCK STRIKER**

– Remove and refit

76.19.12

**Removing**

1. Remove the two bolts and washers securing the striker to the luggage compartment lid.

**Refitting**

2. Refit in reverse order ensuring correct alignment of the striker and lock.
3. Adjust, if necessary, to achieve positive locking by unscrewing the locknut and screwing the catch bolt in or out as required.
4. Retighten the locknut.

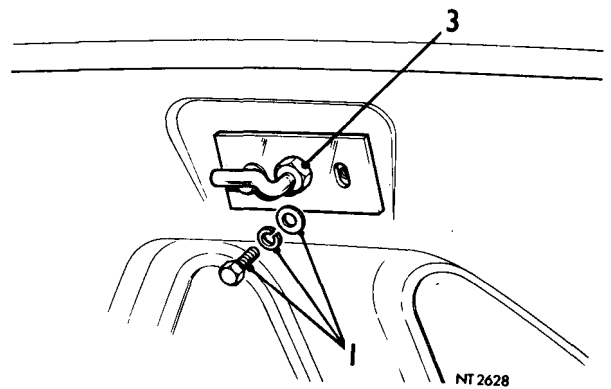

## BODY

### BUMPER – FRONT

– Remove and refit 76.22.08

#### Removing

1. Remove the two bolts and washers securing the bumper to the body.
2. Remove the two bolts and washers securing the bumper to the brackets and lift off the bumper.

#### Refitting

3. Reverse instructions 1 and 2, ensuring that the rubber packing washers are in position between the body and the bumper.

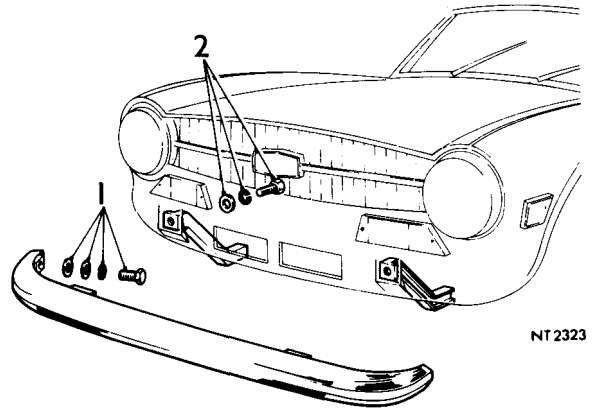

NT 2323

### BUMPER – REAR

– Remove and refit 76.22.15

#### Removing

1. Disconnect the two number plate leads. 86.40.86.  
Disconnect the two number plate leads. 86.40.86  
\*\* (Earlier Models only).\*\*
2. Remove the two bolts and washers securing the bumper to the body and the side brackets.
3. Remove the two bolts and washers securing the bumper to the rear brackets and lift off the bumper.

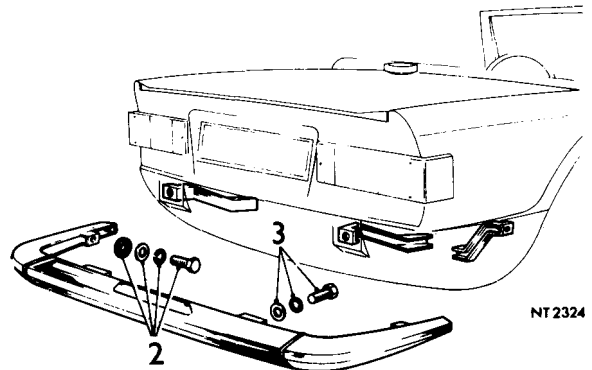

NT 2324

#### Refitting

4. Reverse instructions 1 to 3, ensuring that the rubber packing washers are in position between the body and the bumper.

**CONTROL COWL**

– Remove and refit

76.25.03

**Removing**

1. Remove the bolt and lockwasher securing the cowl reinforcement to the fascia.
2. Depress the four buttons and pull off the control knobs.
3. Unscrew and remove the four bezels.
4. Remove the two screws securing the cowl to the fascia.
5. Withdraw the cowl, noting the control positions for refitting.

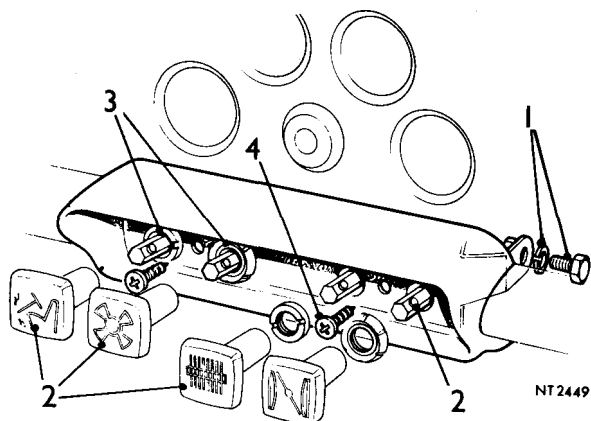

**Refitting**

6. Reverse instructions 1 to 5.

**GEARBOX TUNNEL COVER**

– Remove and refit

76.25.07

**Removing**

1. Remove the seats 76.70.04/76.70.05.
2. Remove the fascia support bracket 76.46.09.
3. Remove the front gearbox cover carpet 76.49.01.
4. Remove the rear gearbox cover carpet 76.49.05.
5. Disconnect the snap connectors (two on non-overdrive, five on overdrive models).
6. Remove the gear lever 37.16.04.
7. Remove the seventeen bolts and washers securing the cover to the floor and bulkhead.
8. Break the seal between the cover, floor and bulkhead and manoeuvre the cover over the gearbox.

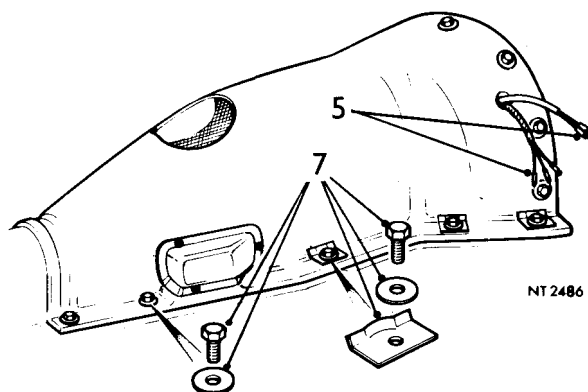

**Refitting**

9. Apply Seelastik SR51 to mating surfaces of seals, cover, floor and bulkhead.
10. Reverse instructions 1 to 8.

# BODY

## DOOR

– Remove and refit

76.28.01

### Removing

1. Isolate the battery.
2. Remove the three screws securing the dash side carpet to the 'A' post.
3. Remove the door check strap 76.40.27.
4. Support the door and remove the six bolts and washers securing the hinges to the 'A' post.

### Refitting

5. Reverse instructions 1 to 4. Check the door closing action and adjust vertical alignment if necessary before fully tightening bolts 4.

**NOTE:** If adjustment in the lateral plane is required, refer to operation 76.28.42 instruction 3.

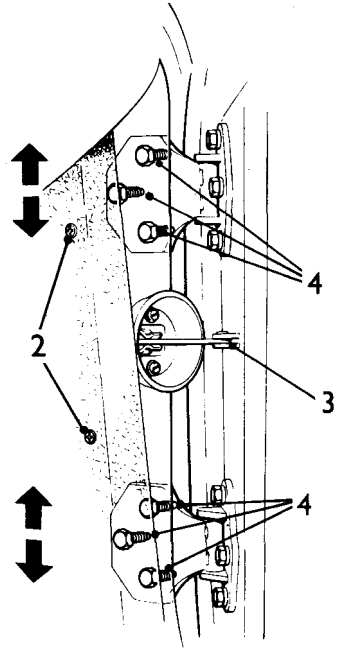

NT 2479

## DOOR HINGES

– Remove and refit

76.28.42

### Removing

1. Remove the door 76.28.01
2. Remove the six bolts and washers securing the hinges to the door.

### Refitting

3. Reverse instructions 1 and 2. Check door closing action and adjust lateral alignment if necessary before fully tightening bolts 2.

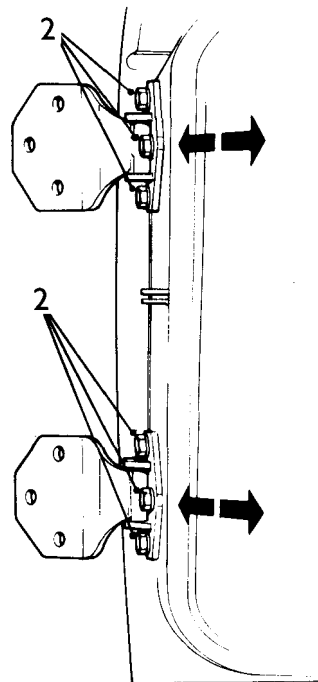

NT 2484

**DOOR GLASS**

– Remove and refit

**76.31.01**

**Removing**

1. Remove the door trim pad 76.34.01.
2. Remove the door glass regulator 76.31.45.
3. Remove the two bolts and washers and push the glass stop to one side.
4. Fully lower the glass.
5. Detach the inner and outer door waist seals from the clips.
6. Carefully lift out the glass.

**NOTE:** Avoid scratching the glass on the seal clips during removal.

**Refitting**

7. Reverse instructions 1 to 6.

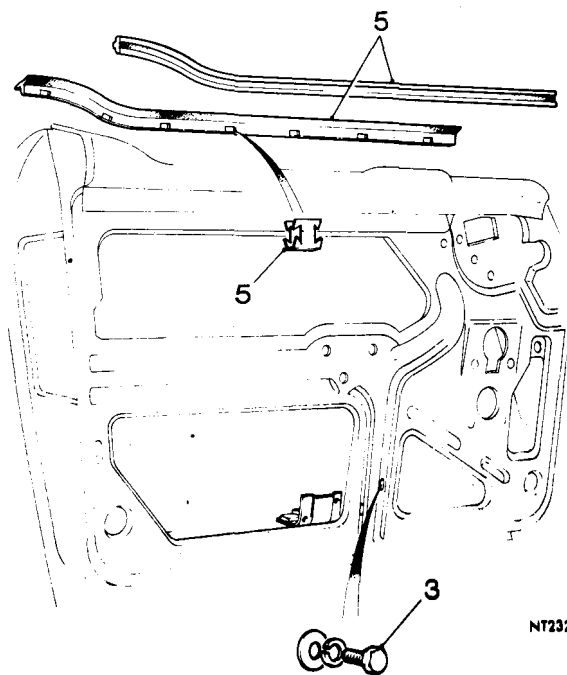

**DOOR GLASS REGULATOR**

– Remove and refit

**76.31.45**

**Removing**

1. Remove the door trim pad.76.34.01.
2. Loosely refit the window winder handle and move the glass to the half open position.
3. Remove the three bolts and washers securing the bracket to the door.
4. Remove the four bolts and washers securing the mechanism to the door.
5. Support the glass and slide the regulator to release the studs from the glass lifting channel.
6. Withdraw the regulator from the door.

**Refitting**

7. Reverse instructions 1 to 6.

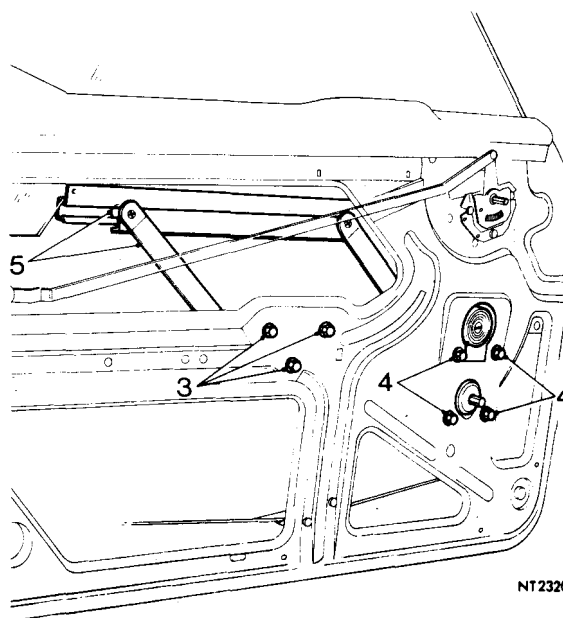

## BODY

### DOOR TRIM PAD

– Remove and refit

76.34.01

#### Removing

1. Depress the bezel and press out the pin.
2. Remove the window winder handle and bezel.
3. Depress the bezel and press out the pin.
4. Remove the remote control handle and bezel.
5. Prise out the two buttons.
6. Remove the two screws and washers.
7. Prise off the trim pad – 15 clips.

#### Refitting

8. Reverse instructions 1 to 7, ensuring that the springs are in position on the window winder and remote control handle shafts before refitting the trim pad.

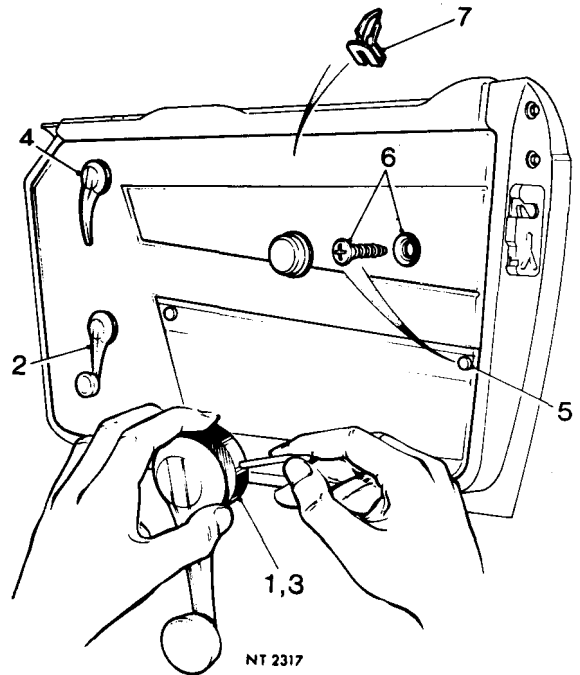

### DOOR LOCK

– Remove and refit

76.37.12

#### Removing

1. Remove the door trim pad. 76.34.01.
2. Loosely refit the regulator handle and fully raise the glass.
3. Remove the spring clip and washer and detach the link arm from the lock.
4. Remove the three screws securing the lock.
5. Raise the locking lever and withdraw the lock.

#### Refitting

6. Reverse instructions 1 to 5.

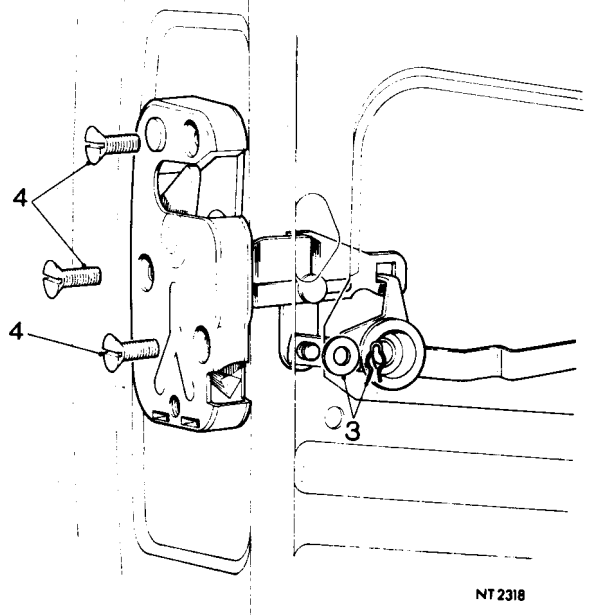

### DOOR LOCK STRIKER

– Remove and refit

76.37.23

#### Removing

1. Remove the three screws and lift off the striker.

#### Refitting

2. Reverse the above, adjusting if necessary to ensure correct door closing action.

76.34.01  
76.37.23

**DOOR LOCK REMOTE CONTROL**

– Remove and refit **76.37.31**

**Removing**

1. Remove the door trim pad 76.34.01.
2. Remove the spring clip and washer and detach the link arm from the lock.
3. Remove the three bolts and washers and lift off the remote control.

**Refitting**

4. Set the latch claw in the fully locked position as shown.
5. Reverse instructions 2 and 3. Position the unit so that the spring loaded lever just contacts the spring before tightening the three bolts.
6. Refit the trim pad 76.34.01.

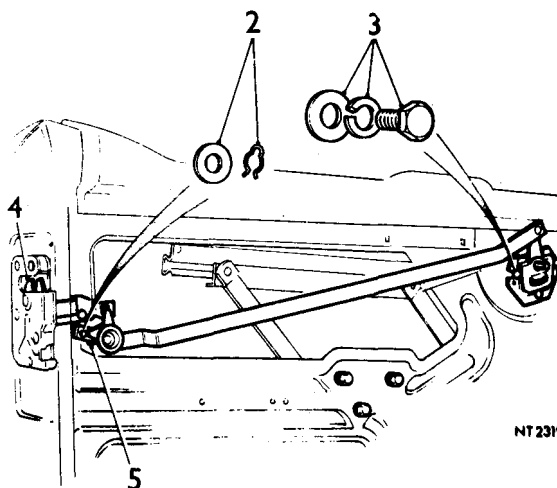

**DOOR PRIVATE LOCK**

– Remove and refit **76.37.39**

**Removing**

1. Remove the door trim pad. 76.34.01.
2. Loosely refit the regulator handle and fully raise the glass.
3. Using a suitable tool, compress the collar legs and withdraw the lock from the outside of the door.

**Refitting**

4. Press the lock into position ensuring that the collar legs are engaged inside the door and the operating fork is located on the door lock control rod.
5. Refit the door trim pad. 76.34.01.

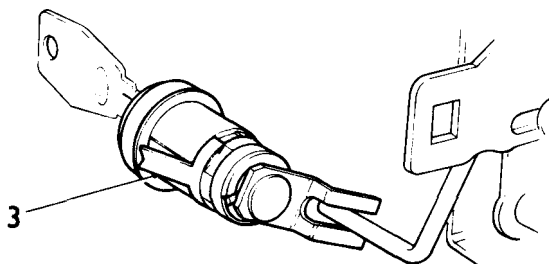

**DOOR CHECK STRAP**

– Remove and refit **76.40.27**

**Removing**

1. Isolate the battery.
2. Remove the three screws securing the dash side carpet to the 'A' post.
3. Drill out the rivet and remove the check strap.

**Refitting**

4. Reverse instructions 1 to 3.

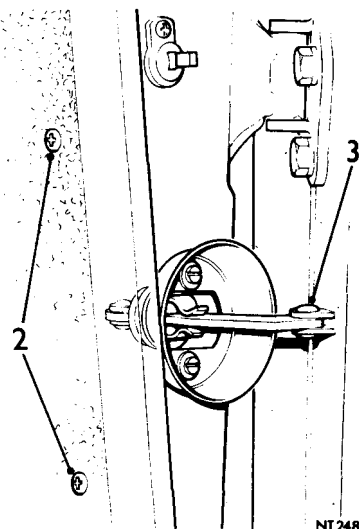

# BODY

## FASCIA – VENEERED

– Remove and refit

76.46.01

### Removing

1. Isolate the battery.
2. Remove the speedometer 88.30.01.
3. Remove the tachometer 88.30.21.
4. Remove the two screws securing the glovebox lid to the check link.
5. Remove the five screws and cup washers securing the veneered fascia to the metal fascia.
6. Carefully lower the fascia to the service position to obtain access to the rear.
7. Pull off the rheostat knob.
8. Remove the windscreen wiper switch 86.65.38.
9. Remove the windscreen washer switch 86.65.40.
10. Remove the hazard warning light switch (if fitted) 86.65.50.
11. Pull out the hazard warning light indicator bulb holder (if fitted).
12. Pull out the brake line failure indicator bulb holder (if fitted).
13. Unscrew the nut securing the pipe to the oil gauge and pull out the bulb holder.
14. Disconnect the two Lucar connectors from the temperature gauge and pull out the bulb holder.
15. Disconnect the two Lucar connectors from the fuel gauge and pull out the bulb holder.
16. Pull out the bulb holder from the seat belt warning light (if fitted).
17. Disconnect the two Lucar connectors from the rheostat.
18. Disconnect the two Lucar connectors from the ammeter and pull out the bulb holder.
19. Remove the fascia from the car.

### Refitting

20. Reverse instructions 1 to 19. Refer to Fascia Connections 86.00.01, to ensure correct reconnection of Lucar connectors.

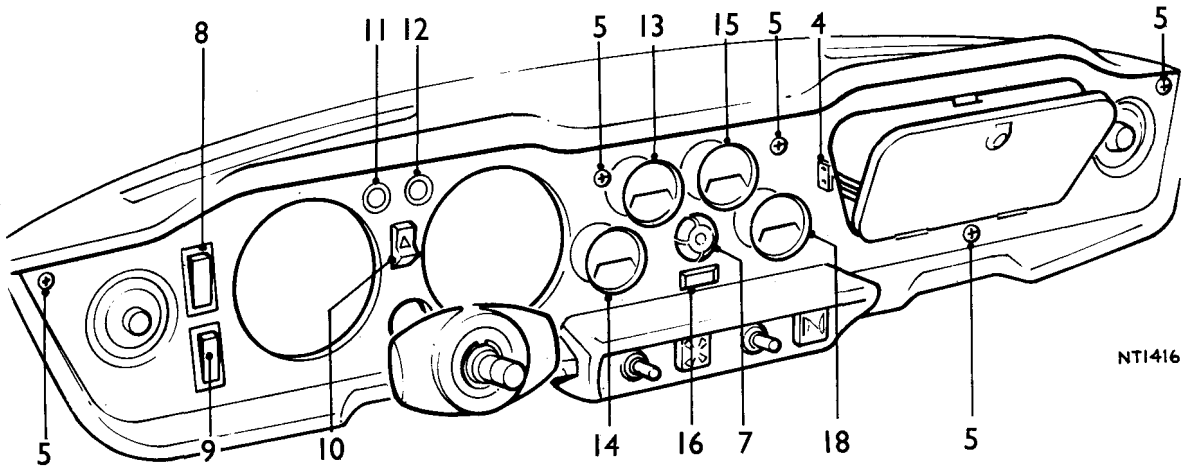

NT1416

## FASCIA CRASH PAD – UPPER

– Remove and refit

76.46.04

### Removing

1. Remove the veneered fascia 76.46.01.
2. Remove the five nuts and washers securing the metal fascia to the crash pad.
3. Remove the two demister ducts 80.15.03.
4. Remove the windscreen frame 76.81.02.
5. Remove the crash pad.

### Refitting

6. Apply S758 adhesive to mating surfaces of the crash pad and the bulkhead panel.
7. Reverse instructions 1 to 5.

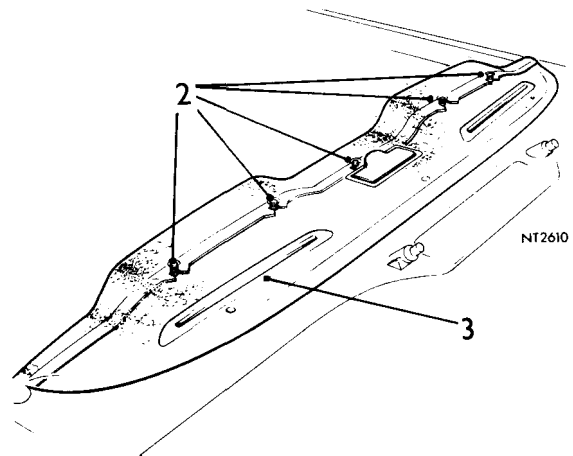

NT2610

76.46.01  
76.46.04