

TM 10-3930-633-12

DEPARTMENT OF THE ARMY TECHNICAL MANUAL

---

TECHNICAL MANUAL

OPERATOR AND ORGANIZATIONAL  
MAINTENANCE MANUAL

TRACTOR, WHEELED, WAREHOUSE

GASOLINE, 4-WHEEL PNEUMATIC

TIRED, 4000 POUND DRAWBAR PULL

(ARMY MODEL MHE-228)

(CLARK EQUIPMENT MODEL 2330237)

NSN 3930-00-347-6173

---

HEADQUARTERS, DEPARTMENT OF THE ARMY  
MARCH 1975

## WARNING

Hydrogen, an explosive gas, is generated by battery.

### DEATH

or severe injury may result if personnel smoke when servicing battery, or if there is flame in the vicinity.

## WARNING

Carbon monoxide, a poisonous gas, is produced by gasoline engines.

### DEATH

or severe injury may result if vehicle is operated in an unventilated area.

## WARNING

Operation of this equipment presents a noise hazard to personnel in the area. The noise exceeds the allowable limits for unprotected personnel. Wear ear muffs or ear plugs which were fitted by a trained professional.

## WARNING

DEATH or severe injury may result if personnel fail to observe the following precautions:

Do not fill tank while engine is running. Provide metallic contact between the fuel container and fuel tank to prevent a static spark from igniting fuel. Wipe or flush any spillage.

Be cautious during operation, when approaching doorways, aisles, intersections or other workers.

Avoid sudden starting and stopping. Reduce speed on turns.

Know the rated capacity of the truck and do not overload it.

Immediately remove from service any vehicle showing a defect or malfunction which might prove hazardous to operating personnel or cause further damage to equipment.

Do not remove radiator cap from an overheated radiator. Stop engine and allow radiator to cool before removing cap to avoid injury by scalding.

If vehicle is parked on an incline, set brakes and block at least 2 wheels as a precaution against hand brake failure.

CHANGE

No. 1

HEADQUARTERS  
DEPARTMENT OF THE ARMY  
Washington D. C., 22 November 1989

**OPERATOR AND ORGANIZATIONAL MAINTENANCE MANUAL**

**TRACTOR, WHEELED, WAREHOUSE  
GASOLINE, 4-WHEEL PNEUMATIC TIRED,  
4000 POUND DRAWBAR PULL  
(ARMY MODEL MHE-228)  
(CLARK EQUIPMENT MODEL 2330237)  
NSN 3930-00-347-6173**

TM 10-3930-633-12, 7 March 1975, is changed as follows:

1. Remove old pages and insert new pages.
2. New or changed material is indicated by a vertical bar in the margin of the page and by a vertical bar adjacent to the TA number.

**Remove Pages**

*iii and iv  
1-1 through 1-4  
3-1 through 3-4  
4-3 and 4-4  
4-45 and 4-46  
4-55 through 4-58  
4-67 through 4-70  
A-1 and "A-2"  
B-1 through B-5  
I-1 through I-4*

**Insert Pages**

*iii and iv  
1-1 through 1-4  
3-1 through 3-4  
4-3 through 4-4  
4-45 through 4-46  
4-55 through 4-58  
4-67/(4-68 Blank) and 4-70  
A-1/(A-2 Blank)  
B-1 through B-9/(B-10 Blank)  
I-1 through I-4*

3. File this change sheet in front of the publication for reference purposes.

By Order of the Secretary of the Army:

Official:

CARL E. VUONO  
*General, United States Army*  
*Chief of Staff*

WILLIAM J. MEEHAN II  
*Brigadier General, United States Army*  
*The Adjutant General*

Distribution:

To be distributed in accordance with DA Form 12-25F (Block Nos. 2278, 2279), Operator and Unit maintenance requirements for Tractor, Warehouse, 4000 LB DBP, Pneumatic Tire, Gas, Model MHE 201. Cumulative.

TECHNICAL MANUAL }  
 No. 10-3930-633-12 }

HEADQUARTERS  
 DEPARTMENT OF THE ARMY  
 WASHINGTON, D.C., 7 March 1975

**OPERATOR AND ORGANIZATIONAL MAINTENANCE MANUAL**  
**TRACTOR, WHEELED, WAREHOUSE**  
**GASOLINE, 4-WHEEL PNEUMATIC TIRED,**  
**4000 POUND DRAWBAR PULL**  
**(ARMY MODEL MHE-228)**  
**(CLARK EQUIPMENT MODEL 2330237)**

**NSN 3930-00-347-6173**

		Paragraph	Page
CHAPTER	1. INTRODUCTION		
Section	I. General	1-1	1-1
	II. Description and Data	1-7	1-1
CHAPTER	2. OPERATING INSTRUCTIONS		
Section	I. Operating Procedures	2-1	2-1
	II. Operation under Unusual Conditions	2-9	2-3
CHAPTER	3. OPERATOR'S MAINTENANCE INSTRUCTIONS		
Section	I. Lubrication Instructions	3-1	3-1
	II. Preventive Maintenance Checks and Services	3-5	3-2
	III. Troubleshooting	3-12	3-5
CHAPTER	4. ORGANIZATIONAL MAINTENANCE INSTRUCTIONS		
Section	I. Service Upon Receipt of Material	4-1	4-1
	II. Movement to a New Worksite	4-6	4-2
	III. Repair Parts, Special Tools, and Equipment	4-7	4-2
	IV. Lubrication Instructions	4-10	4-2
	V. Preventive Maintenance Checks and Services	4-14	4-3
	VI. Troubleshooting	4-15	4-5
	VII. Radio Interference Suppression	4-16	4-10
	VIII. Maintenance of Body	4-20	4-11
	IX. Maintenance of Electrical System	4-24	4-16
	X. Maintenance of Fuel System	4-46	4-35
	XI. Maintenance of Exhaust System	4-61	4-47
	XII. Maintenance of Cooling System	4-63	4-50
	XIII. Maintenance of Engine	4-68	4-55
	XIV. Maintenance of Wheels and Wheel Bearings	4-74	4-60
	XV. Maintenance of Brake System	4-76	4-62
	XVI. Maintenance of Rear Drive Axle and Springs	4-82	4-73
	XVII. Maintenance of Steering System	4-85	4-74
	XVIII. Maintenance of Front Axle and Springs	4-88	4-77
	XIX. Maintenance of Pintle Hook	4-92	4-78
A PPENDIX	A. REFERENCES		A-1
	B. MAINTENANCE ALLOCATION CHART		B-1
	C. BASIC ISSUE ITEMS LIST AND ITEMS TROOP INSTALLED OR AUTHORIZED LIST		C-1
INDEX			I-1



## LIST OF ILLUSTRATIONS

<i>Fig. No.</i>	<i>Title</i>	<i>Page</i>
1-1.	Wheeled Warehouse Tractor . . . . .	1-2
2-1.	Controls and Instruments . . . . .	2-1
3-2.	Checking Battery Specific Gravity . . . . .	3-5
4-1.	Repacking Hubs and Bearings . . . . .	4-3
4-1.1.	Engine Oil Filter . . . . .	4-3
4-1.2.	Transmission Oil Filter . . . . .	4-3
4-2.	Interference Suppression Components, Sheet 1 of 2 . . . . .	4-3.0
4-2.	Interference Suppression Components, Sheet 2 of 2 . . . . .	4-10
4-3.	Frame and Body Parts . . . . .	4-11
4-4.	Seat Assembly and Mounting . . . . .	4-13
4-5.	Electrical System . . . . .	4-15
4-6.	Ignition System Circuit . . . . .	4-17
4-7.	Starting System . . . . .	4-18
4-8.	Alternator Output Test Circuit . . . . .	4-19
4-9.	Starter Details . . . . .	4-20
4-10.	Spark Plug Wiring . . . . .	4-22
4-11.	Point Alignment Chart . . . . .	4-24
4-12.	Aligning Breaker Points . . . . .	4-25
4-13.	Adjusting Point Gap . . . . .	4-25
4-14.	Checking and Adjusting Breaker Point Spring Tension . . . . .	4-26
4-15.	Timing Marks . . . . .	4-26
4-16.	Distributor and Coil Installation . . . . .	4-27
4-17.	Battery and Regulator Mounting . . . . .	4-28
4-18.	Instrument Panel and Gages... . . . .	4-30
4-19.	Headlamp Installation . . . . .	4-31
4-20.	Stop and Tail Lamp Installation . . . . .	4-33
4-21.	Horn and Horn Relay . . . . .	4-34
4-22.	Fuel System . . . . .	4-34
4-23.	Fuel Tank Installation.. . . . .	4-36
4-24.	Fuel Lines Installation . . . . .	4-37
4-25.	Fuel Pump Test Set-up . . . . .	4-38
4-26.	Fuel Pump . . . . .	4-39
4-27.	Air Cleaner Assembly . . . . .	4-41
4-28.	Air Intake System . . . . .	4-42
4-29.	Carburetor Adjustments . . . . .	4-43
4-29.1.	Carburetor Assembly, Exploded View . . . . .	4-44
4-29.2.	Pump Adjustment . . . . .	4-45.0
4-30.	Governor Assembly . . . . .	4-45.1
4-31.	Accelerator Pedal and Linkage . . . . .	4-46
4-32.	Exhaust System . . . . .	4-47
4-33.	Cooling System . . . . .	4-49
4-34.	Water Pump . . . . .	4-51
4-35.	Belt Tension Adjustment . . . . .	4-53
4-39.	Manifolds Removal . . . . .	4-54
4-40.	Manifolds Installation . . . . .	4-57
4-41.	Manifold Bolts Torque Sequence . . . . .	4-58
4-42.	Wheel Removal . . . . .	4-59
4-43.	Wheel Bearings and Seals . . . . .	4-60
4-44.	Front Wheel Bearings . . . . .	4-61
4-45.	Rear Wheel Bearings . . . . .	4-62
4-46.	Adjusting Pedal Free Travel . . . . .	4-62
4-47.	Brake System Bleeding . . . . .	4-63
4-48.	Adjustment Cams . . . . .	4-65
4-49.	Master Cylinder Installation . . . . .	4-66
4-52.	Parking Brake Adjustments . . . . .	4-67
4-53.	Band Centering Adjustment . . . . .	4-70
4-54.	Lower Band Adjustment . . . . .	4-70
4-55.	Upper Band Adjustment . . . . .	4-71
4-56.	"Parking Brake Assembly . . . . .	4-72
4-57.	Differential and Drop Gear Case . . . . .	4-74
4-58.	Steering System . . . . .	4-75
4-59.	Drag Link... . . . .	4-76

<i>Fig. No.</i>	<i>Title</i>	<i>Page</i>
4-60.	Steering Gear Thrust Adjustment . . . . .	4-77
4-61.	Steering Gear Lash Adjustment . . . . .	4-77
4-62.	Front Axle . . . . .	4-78
4-63.	Pintle Hook Coupler . . . . .	4-79



## LIST OF TABLES

<i>Table No.</i>	<i>Title</i>	<i>Page</i>
2-1.	Controls and Instruments . . . . .	2-1
3-1.	Operator Preventive Maintenance Checks and Services . . . . .	3-2
3-2.	Freezing Points, Composition, and Specific Gravities of Military Antifreeze Materials . . . . .	3-4
3-3.	Troubleshooting. . . . .	3-6
4-1.	Organizational Preventive Maintenance Checks and Services . . . . .	4-4
4-2.	Troubleshooting . . . . .	4-6
4-3.	Spark Plug Condition Analysis.. . . . .	4-23
4-4.	Engine Tune-up Specifications . . . . .	4-25



# CHAPTER 1

## INTRODUCTION

---

### Section I. GENERAL

#### 1-1. Scope

This manual is for your use in operating and maintaining the Army Model MHE-228 Warehouse Tractor.

#### 1-2. Maintenance Forms, Records, and Reports

Maintenance forms and records that you are required to use are explained in DA PAM 738-750.

#### 1-3. Reporting Errors and Recommending Improvements

You can help improve this manual. If you find any mistakes or if you know of a way to improve the procedures, please let us know. Mail your letter, DA Form 2028 (Recommended Changes to Publications and Blank Forms), or DA Form 2028-2, located in

the back of this manual, direct to: Commander, U.S. Army Tank-Automotive Command, ATTN: AMSTA-MB, Warren, MI 48397-5000, A reply will be furnished to you.

#### 1-4. Equipment Serviceability Criteria (ESC)

This equipment is not covered by an ESC.

#### 1-5. Destruction of Army Materiel to Prevent Enemy Use

Refer to TM 750-244-6 for procedures covering destruction of this vehicle to prevent enemy use.

#### 1-6. Administrative Storage

Preparation, care, and removal of equipment in administrative storage will be in accordance with the applicable requirements of TM 740-90-1 (Administrative Storage of Equipment).

### Section II. DESCRIPTION AND DATA

#### 1-7. Description

*a.* The wheeled warehouse tractor, shown in figure 1-1, is designed for use in warehousing

operations, for towing trailers and other wheeled loads. A pintle hook is provided at the rear of the vehicle for the attachment of the load.

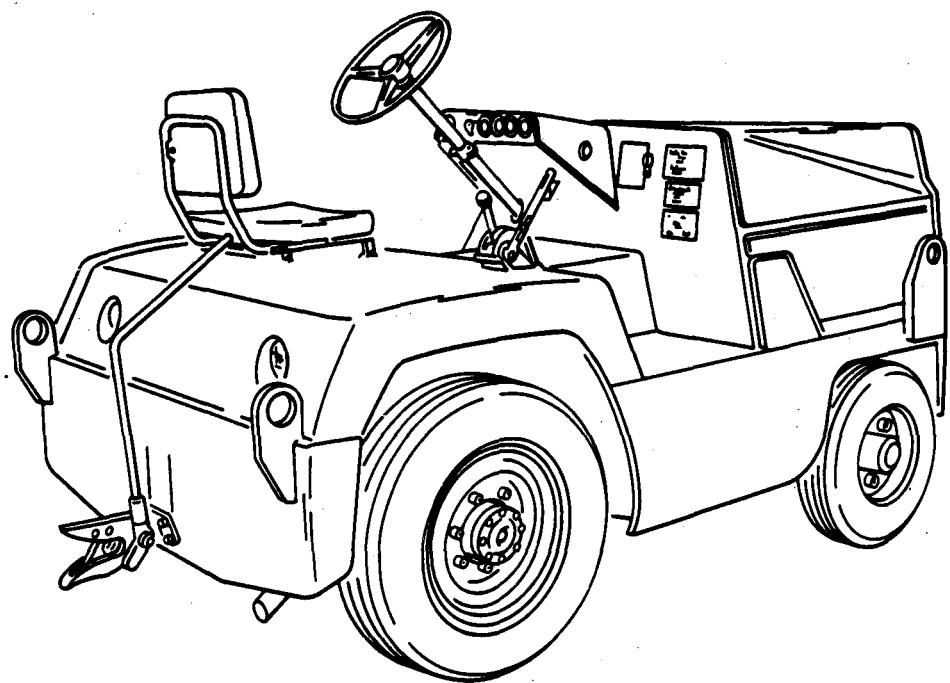
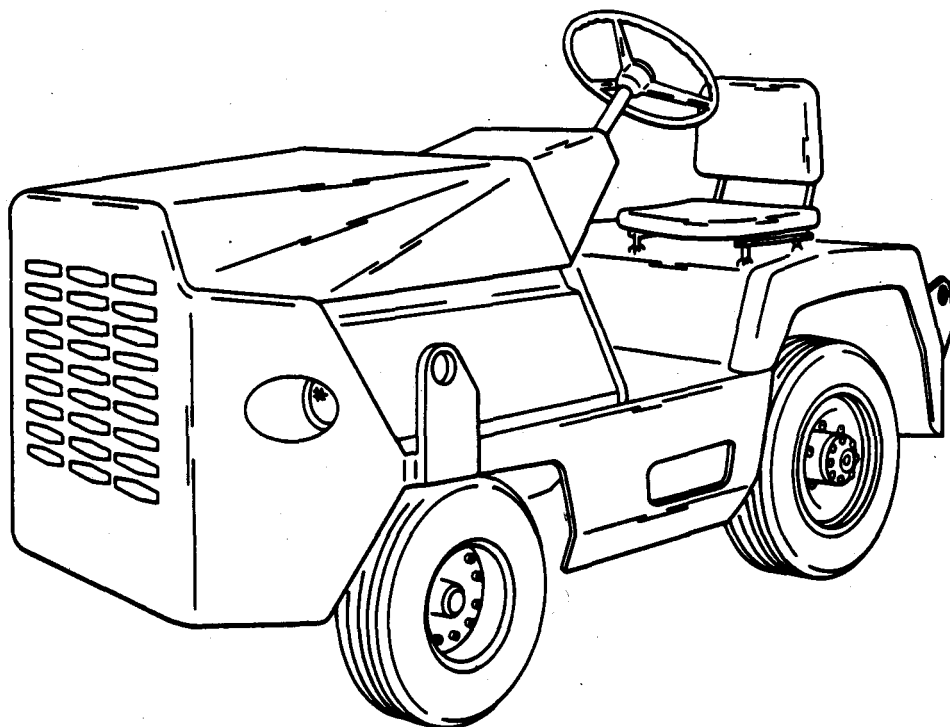

TA501869 ■

Figure 1-1. Wheeled Warehouse Tractor.

b. The tractor is designed for high maneuverability and ease of operation in warehousing and transfer operations. The vehicle is built in accordance with conventional design for automotive-type vehicles, and is equipped with a gasoline engine, two-speed automatic transmission, pneumatic tires, " and hydraulic, power

booster brakes, The maintenance paragraphs of this manual contain detailed descriptions of all components.

1-8. Tabulated Data

a. *Identification.* The tractor has an identification plate mounted to the top right of the

firewall in the operator's compartment. This plate specifies model, serial, contract, and registration numbers, federal stock number, basic overall dimensions and weight, and warranty information. Mounted below the identification plate is a transportation data plate.

*b. Tabulated Data.*

**(1) Identification plate.**

Model . . . . . CT"E"-40  
 Contract No. . . . . DSA700-73-C-9490  
 Serial No. . . . .  
 Capacity . . . . . 4000 lb drawbar pull  
 Reg. No. . . . .  
 GVW . . . . . : 5 8 0 0 lb  
 NON . . . . . 3930-00-347-6173  
 Length . . . . . 112.5 in.  
 Height . . . . . 64.0 in.  
 Width . . . . . 55.5 in.  
 Cube . . . . . 231.2 ft.

**(2) Shipping data plate.**

Technical manual number TM 10-3930-633-12  
 Center of Gravity:  
 Horizontal from center drive wheel axle . . . in.  
 Vertical above center drive wheel axle . . . in.  
 Lifting eye capacity (each) 1500 lb

**(3) Engine.**

Manufacturer . . . . . Ford Motor Co.  
 Model . . . . . 300LD-IV  
 Cylinders . . . . . 6-in line  
 Bore (inches) . . . . . 4.000  
 Stroke (inches) . . . . . 3.980  
 Displacement . . . . . 300 cu. in  
 Governed speed (no-load) 2700 RPM  
 Governed speed (loaded) 2600 RPM  
 Maximum gross horse power @ 2750 RPM 107  
 Maximum torque @ 2400 RPM 294 ft/lb  
 Taxable horse power 38.4  
 Firing order . . . . . 1-5-3 -6-2-4  
 Engine idle . . . . . 500 -550 RPM  
 Engine idle manifold vacuum 17 in./Hg  
 Ignition timing .6° BTDC  
 Oil pressure . . . . . 35-60 PSI  
 Valve lash (hot and cold) 0  
 Crankcase capacity with filter 6 quarts  
 Without filter 5 quarts

**(4) Transmission**

Model . . . . . Ford FMX  
 Speeds . . . . . :2 forward. 1 reverse (low gear blocked out in drive range)

Gear ratio:

Low . . . . . :1.47 to1.0  
 High . . . . . 1.0 to1.0  
 Reverse . . . . . :2.0 to 1.0

**(5) Wheels and tires.**

Front wheels:

Tire size . . . . . 6:50x10-6 ply  
 Pressure . . . . . 100 PSI  
 Wheel nut torque . . . . . 60-75 ft/lb

Rear wheels:

Tire size . . . . . 6:50x16-6 ply  
 Pressure . . . . . 45 PSI  
 Wheel nut torque . . . . . 125-140 ft/lb

**(6) Spark plugs.**

Gap (inches) . . . . . 0.032-0.036  
 Torque . . . . . 15-20 ft/lb

**(7) Battery (negative ground).**

volts . . . . . 12  
 Number of cells . . . . . 6  
 Number of plates . . . . . 11  
 20 hour rate A.H. . . . . 70 ampere hours 300 amps, 0° F. (10 sec.) 2.0 minutes to one volt per cell

**(8) Starting motor.**

Cranking speed (normal engine) 250-290 RPM  
 Brush spring tension (oz) . . . . . 40  
 Brushes (wear limit, inches) 0.25  
 Brush length (inches) . . . . . 0.5  
 Current draw (amps) under normal load 150-180  
 volts (minimum stall torque @ volts) 5  
 Torque (ft/lb) (minimum stall torque @ 5 volts) 15.5  
 Maximum starting circuit voltage drop (battery plus terminal to starter terminal) @ normal engine temperature 0.5 volts  
 No-load (amperes) 70  
 Mounting bolt, 2-hole (3/8") bolt torque (ft/lb) 15-20

**(9) Alternator.**

System voltage . . . . . 12  
 System ground . . . . . negative  
 Amperes . . . . . 32  
 Maximum ambient temperature 200° F  
 Rotation . . . . . CW  
 Pulley nut torque (ft/lb) . . . . . 40-60  
 Battery terminal nut torque (in. /lb) . . . . . 20-25  
 Ground terminal nut torque (in. /lb), . . . . . 15-20  
 Field coil draw @ 80° F. 2.2-2.6 Amps @12 volts  
 Rated hot output . . . . . 32 Amps  
 Output test @ 80° F. 14 volts, 21 Amps @2000 RPM (Approx) and 30 Amps @5000 RPM (Approx)  
 Charging starts cold 1000 RPM (Alternator)  
 Charging starts hot . . . . . 1050 RPM (Alternator)

**(10) Dimensions and weights,**

Rear tread . . . . . :54.5 in.  
 Turning radius:  
 Outside . . . . . :108 in.  
 Inside . . . . . 29 in.  
 Ground clearance (under counterweight tow hitch or mounting) . . . . . 11 in.  
 Ground clearance (under rear axle) . . . . . :7 in.

**TM 10-3930-633-12**

Ground clearance (under front axle) . . . . . 6½ in.  
Ground clearance between axles . . . . . 8 in.  
Grade clearance . . . . . 34%  
Drawbar pull 2000 to 5000 lbs, at 12 in. coupler height  
Travel speeds, without load:  
1st . . . . . 8.9 MPH  
2nd . . . . . 13.1 MPH  
Rev . . . . . 6.5 MPH

**(11) Capacities.**

Crankcase oil (incl. filter) 6 quarts

Transmission oil . . . . . 11 quarts  
Rear axle . . . . . 10 quarts  
Cooling system . . . . . 16 quarts  
Fuel tank . . . . . 17 gallons

**1-9. Differences in Models**

**This manual covers the Army Model MHE-228 Wheeled Warehouse Tractor, (Clark Equipment Model 2330237). No differences exist in the units delivered under this contract.**

## CHAPTER 2

### OPERATING INSTRUCTIONS

#### WARNING

If equipment fails to operate, refer to trouble shooting procedures in Chapter 3.

#### Section I. OPERATING PROCEDURES

##### 2-1. General

This section illustrates and describes the various controls and instruments and provides the operator sufficient information to ensure proper operation of the tractor.

##### 2-2. Controls and Instruments

All controls and instruments for operation of the

tractor are illustrated in figure 2-1. The table accompanying the illustration explains the function of each control and gives the normal reading for each gage.

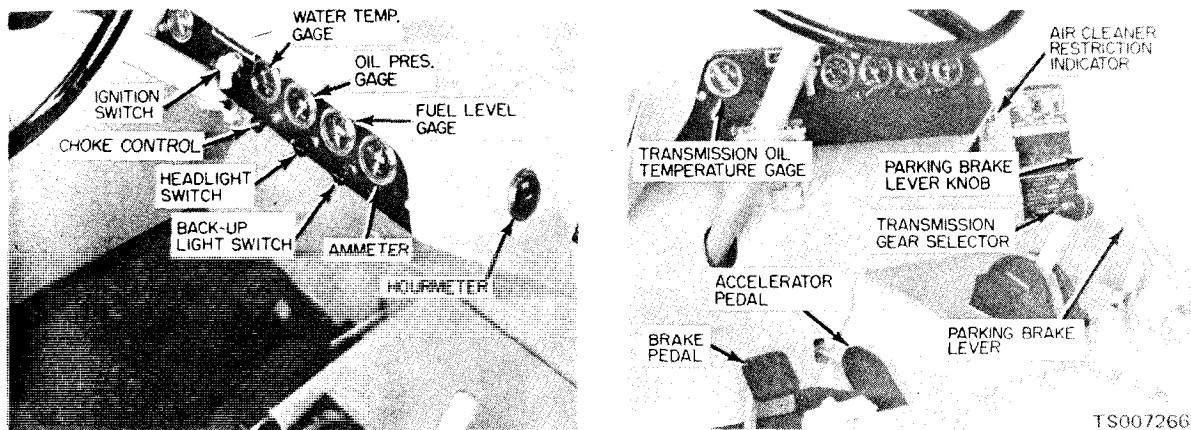

*Figure 2-1. Controls and Instruments*

*Table 2-1. Controls and Instruments*

Nomenclature	Normal Use or Reading
Ignition Switch	When turned clockwise to ON, energizes engine ignition, instruments, and accessory circuit. Turning fully clockwise against spring pressure engages engine starter. Turning counterclockwise to OFF shuts off engine and disconnects gages and accessory circuits.
Water Temperature Gage	Indicates temperature of engine coolant in degrees (° F). Normally 175° F.-200° F. ( 79° C-93° C)
Oil Pressure Gage	Indicates engine lubricating oil pressure in PSI. Normally 15-80 PSI (40-60 PSI @ 2000 RPM).
Fuel Level Gage	Indicates quantity of fuel remaining in fuel tank. E = empty, F = full (tank capacity is 17 gallons).
Ammeter	Indicates rate of battery charge of discharge. With engine running, should read slightly to the + side of 440. "
Transmission Oil Temperature Gage	Indicates transmission fluid temperature at converter outlet. DO NOT ALLOW TEMPERATURE TO EXCEED 250° F. (121° C)
Light Switch	Pull out to illuminate headlights and taillamp. Push in to turn off lights.
Air Cleaner Restriction Indicator	Signals when air cleaner element is dirty by displaying read signal. Normally clear.
Choke Control	Pull out to choke engine for cold starting.

Nomenclature	Normal Use or Reading
Back-up Light Switch Hourmeter Service Brake Pedal Accelerator Transmission Gear Selector Parking Brake Lever Brake Lever Knob Horn Button Seat Adjustment Lever	Pull out to illuminate rear light, Push in to turn off light. Indicates total engine operating time in hours and tenths. Depress to apply service brakes. Depress to increase engine speed. Selects desired forward gear, reverse, or neutral. Pull back to apply parking brake; push forward to release parking brake. Turn clockwise to tighten linkage and remove slack. Depress to sound horn. Pull outward to permit fore and aft adjustment of seat position.

**2-3. Preparation for Start-up**

**WARNING**

Operation of this equipment presents a noise hazard to personnel in the area. The noise exceeds the allowable limits for unprotected personnel. Wear ear muffs or ear plugs which were fitted by a trained professional.

- a. Perform Operator's Daily Checks as outlined in table 3-1.
- b. Pull up on parking brake lever to make certain truck will remain stationary while it is being started.
- c. Make certain the direction shift lever is in neutral (N) position.

2-4. Starting the Engine

**WARNING**

**Do not operate vehicle for prolonged periods in an unventilated area. All gasoline engines produce poisonous carbon monoxide gas which is extremely toxic if allowed to accumulate in a closed area.**

- a. At initial starting, or if engine is cold, pull choke control all the way out.
- b. Press down on accelerator pedal approximately one-third the distance from its normal position.

**CAUTION**

**Do not operate the starter motor continuously for more than 30 seconds. If the engine fails to start after 30 seconds, allow the starter motor to cool for at least two (2) minutes before attempting to start the engine again.**

- c. Turn ignition switch fully clockwise, against spring tension, to the START position, and hold while the starter cranks the engine. As soon as the engine starts, release the switch.

NOTE

If engine becomes over-choked or carburetor floods, push choke button in, depress accelerator pedal fully, and engage starter. If all equipment is in working order, the engine should start.

- d Hold accelerator pedal steady and allow

engine to warm up at a fast idling speed. Immediately observe engine oil pressure gage and ammeter for normal readings. As engine begins to warm up, gradually push in on choke control; as soon as engine is warm, push choke control all the way in.

- e. Warm engine until it will idle smoothly with the choke control pushed all the way in. Check for proper reading on ammeter, engine oil pressure gage, engine temperature indicator, and fuel gage. Be sure hourmeter is operating properly.
- f. Remove foot pressure from accelerator pedal. Report any malfunctions to the proper authority.

**2-5. Mobile Operation**

Operation of this vehicle is essentially the same as that for any automotive-type equipment; all controls and instruments are positioned conveniently for operators use, and in approximately the same location or relationship as that used in an ordinary truck or passenger car. Operators should familiarize themselves with the steering and performance characteristics of the vehicle before attempting to perform any actual towing operations. Sudden starts, stops, and turns are to be avoided except in cases of emergency.

**2-6. Towing Operations**

During towing operations, keep vehicle in a gear range that will provide adequate torque for negotiation of grades. Vehicle speed must be kept low enough that the vehicle and load can be safely stopped, within an assured clear distance.

- a. Always check the pintle hook connection to see that the hook is properly engaged with the drawbar eye or coupling.
- b. When negotiating turns or operating in areas where clearances are restricted, always take into consideration the physical size and steering characteristics of the load being towed.
- c. When towing loads at or near maximum capacity, and operating in low range continuously, closely monitor transmission oil temperature warning light. This light will come



on when oil temperature reaches 250°F. (121°C). DO NOT ALLOW OIL TEMPERATURE TO EXCEED 250°F. (121°C). If temperature reaches 250°F. (121°C), stop vehicle, shift to neutral range and run engine at a fast idle until oil temperature drops back to a normal level.

### 2-7. Stopping the Tractor

- a. Remove foot from accelerator pedal.
- b. Apply gradual foot pressure to the brake pedal to bring the vehicle to a smooth, safe stop. Avoid sudden application of full braking effort except in cases of emergency.
- c. Shift to neutral range and apply parking brake.
- d. Turn ignition switch to OFF to shut down engine.

#### CAUTION

**If the engine has been operating at, or near, full load, it should be allowed to run at fast idle (600 to 800 RPM) for several minutes after the load is removed before being stopped. This allows internal engine temperatures to equalize.**

### 2-8. Safety Precautions

The operation of powered equipment is subject to certain limitations that cannot be overcome by purely mechanical means. The exercise of intelligence, caution, and common sense by the operator is essential in order to minimize the hazards of overloading, slippery travel surfaces, obstructions in the path of travel, or the use of equipment in operations for which it is neither designed nor intended. Following are a few suggestions that should be followed in the safe operation of this vehicle.

a. The operator should be qualified and drive in accordance with safety rules.

b. If the vehicle does not operate properly, report to proper authority. A minor adjustment now may save a major repair later.

c. Avoid sudden stops or starts. When backing up, check for obstructions or personnel in the path of the vehicle before moving.

d. Drive carefully at all times. Exercise caution at cross aisles, sounding horn for safety.

e. Do not allow riders.

f. Operate the vehicle at a safe distance behind other vehicles.

g. Do not operate vehicle with wet or greasy hands.

h. Observe highway traffic laws in the operation of the vehicle.

i. Drive carefully on wet or slippery floors.

j. Keep feet within perimeter of floor board.

k. Observe the Operating Instructions and Preventive Maintenance Instructions given in this manual.

l. Avoid overloading the vehicle— this is a hazardous practice, for the operator as well as the equipment. Overloading shortens the life of the vehicle and increases maintenance costs.

#### NOTE

1,000 pounds of drawbar pull will tow a 10,000 pound load on a 4-wheel trailer, including the weight of the trailer.

m. Be sure the brakes are in proper working condition. Be sure all mechanical and electrical components are in good working order prior to each shift of operation.

## Section II. OPERATION UNDER UNUSUAL CONDITIONS

### 2-9. General

The following paragraphs present special procedures to be observed when operating the tractor in unusual extremes of temperature or environmental conditions. These procedures are in addition to all normal precautions and service intervals.

### 2-10. Operation in Extreme Heat

#### a. Cooling System.

- (1) Make sure fan belts are properly adjusted.
- (2) Check coolant level frequently, and be sure radiator cap is secure.
- (3) Keep exterior of radiator clean and free of

foreign matter which might affect circulation of air.

(4) Flush and clean cooling system frequently.

b. *Battery.* Check electrolyte level frequently and maintain at proper levels.

c. *Lubrication.* Make certain that tractor is serviced according to instructions of the Lubrication Order LO 10-3930-633-12.

d. *Fuel System.* Fill fuel tank at the end of each period of operation to expel trapped water vapor and prevent condensation.

### 2-11. Operation in Extreme Cold

a. *Shelter.* The truck should be sheltered in a

closed building with some heat, if possible. If this is not possible, cover with a tarpaulin or similar kind of material.

*b. Cooling System.* Add proper amount of ethylene glycol antifreeze to cooling system. A solution of 7½ quarts ethylene glycol and 7 quarts of water will afford protection at -350 F (-37° C). If antifreeze is not available, drain radiator and cylinder block when ambient temperature is expected to drop below 32° F (0° C). Never add water to the cooling system without subsequently checking the antifreeze solution for adequate strength and adding antifreeze if necessary.

*c. Electrical System.*

(1) Test the specific gravity of the electrolyte in the battery, using a hydrometer. Specific gravity reading should be between 1.260 and 1.275 at 80° F (26.7° C).

(2) Electrolyte level of battery must be maintained at ½ inch above plates. Do not add water to a battery which has been exposed to cold temperature except when engine is to be operated immediately.

(3) Remove battery and store it in a warm place when shelter for truck is not available. The efficiency of the battery decreases at lower temperatures, and a completely discharged battery will freeze at 20° F.

(4) Be sure that wires and cables are in good condition and that all connections are clean, dry and secure.

(5) Clean spark plugs and check gaps.

(6) Be sure terminal sockets and spark plug terminals are clean.

*d. Lubrication.* Make certain that tractor is serviced in accordance with instructions of the Lubrication Order LO 10-3930-633-12.

*e. Fuel System.*

(1) Drain the fuel filter often to expel trapped moisture and prevent icing.

(2) Fill the fuel tank at the end of each period of operation to expel trapped moisture and prevent condensation of water in the fuel tank.

## **2-12. Operation in Humid Climates**

In tropical areas, if paint is chipped, or scratched, the affected area should be refinished immediately to prevent rapid formation of rust. Remove all loose paint with paint remover, sandpaper, or sandblasting equipment. Apply two coats of red lead primer and, when dry, apply finishing coat of paint.

## **2-13. Operation in Dusty Conditions**

Operators of tractors used in extremely dusty conditions should check the air cleaner daily to insure that excessive build-up of dust or dirt, which would restrict air flow, is not permitted. Lubrication service intervals for all items should be reduced to one-half the normal period, or as short as 50 hours, depending upon the severity of the service.

## CHAPTER 3

# OPERATOR'S MAINTENANCE INSTRUCTIONS

---

### Section I. LUBRICATION INSTRUCTIONS

#### 3-1. Lubrication

a. Refer to Lubrication Order LO 10-3930-633-12 for all lubrication procedures authorized at organizational level. Supplementary instructions to the Lubrication Order are contained in the following paragraphs.

b. Use only, the lubricants specified in the lubrication order, Carefully follow instructions given on the lubrication order to assure proper operation of the equipment.

#### 3-2. Detailed Lubrication Information

a. *General.* Keep all lubricants in closed containers and store in a clean, dry place away from external heat. Allow no dust, dirt, or other foreign material to mix with the lubricants. Keep all lubrication equipment clean and ready for use.

b. *Cleaning.* Keep all external parts not requiring lubrication clean of lubricants. Before lubricating the equipment, wipe all lubrication points free of dirt and grease. Clean all lubrication

points after lubrication to prevent accumulation of foreign matter.

c. *Points of Lubrication.* Service the lubrication points at proper intervals as illustrated in the lubrication order.

#### 3-3. Engine Crankcase Oil and Filter Change

Paragraph 3-3 and Figure 3-1 have been rescinded.

#### 3-4. Transmission Oil Change

Paragraph 3-4 has been rescinded.

Section II. PREVENTIVE MAINTENANCE CHECKS AND SERVICES

**3-5. Operator's Preventive Maintenance Checks and Services**

To insure equipment fitness for operation at all times, and to hold corrective maintenance downtime to a minimum, a regular inspection schedule must be established and maintained for the tractor. The procedures contained herein, properly followed, will reveal defects and worn, damaged, or substandard parts, and will provide a record of these findings so these conditions may be corrected at the next maintenance interval.

**3-6. Records**

All deficiencies and shortcomings will be noted, together with the corrective action taken on DA

Form 2404 (Equipment Inspection and Maintenance Worksheet) at the earliest opportunity.

**3-7. Schedule**

Perform the Preventive Maintenance Checks and Services in accordance with the instructions and intervals specified in table 3-1.

**WARNING**

**Immediately remove from service any vehicle evidencing a defect or malfunction which might prove hazardous to operating personnel, or cause further damage to equipment. Such defects must be corrected immediately, regardless of scheduled maintenance actions.**

Table 3-1. Operator Preventive Maintenance Checks and Services

B = Before Operation Time Required: 1.2				D = During Operation Time Required: 0.5	A = After Operation Time Required: 0.4	W = Weekly Time Required: 2.4	Work Time (M H)
Interval and Sequence No				Item to be Inspected Procedure			
B	D	A	w				
				NOTE			
1		12	1	Visually inspect for evidence of fuel and lubricant leaks during daily service checks. <b>FUEL TANK AND LINES</b> Check fuel level before start-up and replenish fuel supply if necessary.			0.1
				<b>WARNING</b>			
				<b>Do not fill fuel tank when engine is running. Always provide a metal-to-metal contact between spout and fuel filler neck to prevent possibility of a static spark. Wipe or rinse away any fuel spillage.</b>			
	8		2	Check for leaks at tank and fuel line connections to filter and carburetor. <b>RADIATOR</b>			0.3
			3	Check coolant level and add water or water-antifreeze solution as required to bring coolant level to FULL. Refer to paragraph 3-8.			0.2
		13	4	Check for coolant leakage at radiator and hose connections to water pump and engine.			0.1
			5	<b>ENGINE</b> Check oil level before start-up.			0.1
			6	<b>WHEELS, TIRES AND TUBES</b> Check wheel mounting nuts for security; tighten nuts as required.			0.2
			7	Check for proper tire pressure. Add air to bring tire pressure (cold) to figure marked above each wheel well.			0.1
		14	8	Check tires for cuts, bruises, and imbedded stones, glass, metal or other objects. Note tread wear pattern.			0.2
			9	<b>HAND BRAKE</b> Check operation of hand brake to determine if proper tension exists in the applied position. Perform adjustment as outlined in paragraph 3-9.			0.2

B = Before Operation

D = During Operation

A = After Operation

W = Weekly

Interval and Sequence No.				Item to be Inspected Procedure	Work Time (M H)
B	D	A	w		
	9		10	<b>GAGES AND SWITCHES</b> After start-up, observe all gages including hourmeter, for proper operation and indication. See table 2-1 for proper gage readings. Check operation of light switches and horn.	0.2
	10		11	<b>AIR CLEANER</b> Check air cleaner restriction indicator for indication of dirty element, requiring replacement.	0.1
			12	<b>ACCELERATOR AND LINKAGE</b> Check condition of accelerator and linkage, and straighten or replace any bent rods or links with worn pivot holes. Check for weakened or broken springs, and replace as required. Adjust linkage in accordance with instructions in Section X.	
			13	<b>SEAT AND MOUNTING</b> Check seat for secure mounting and proper operation of adjust mechanism.	0.1
			14	<b>BATTERY AND CABLES</b> Check level of water and state of charge of storage battery. See paragraph 3-10  <div style="text-align: center;"><b>WARNING</b></div> <b>Do not smoke or allow any open flame in the vicinity while checking or filling battery. This battery generates hydrogen, a highly explosive gas.</b>	0.2
			15	Check battery cable terminals for tight fit and cleanliness. Refer to paragraph 3-11.	0.1
	11		16	<b>MUFFLER AND PIPES</b> Check muffler and pipes for freedom from leaks or loose connections. Also check mounting of supports and hangers.	0.2

**3-8. Engine Coolant**

a. Check the engine coolant level before the start of every shift. If necessary, add water or antifreeze as required by the ambient temperature. The recommended coolant level is 1 inch from the top of the radiator.

**CAUTION**

**Never add cold coolant to a hot engine.**

**WARNING**

**The cooling system is pressurized. When removing the radiator cap while the engine is hot, turn it slowly to allow the pressure to escape before fully removing**

**the cap. Sudden removal of the cap may result in serious burns, or injury from being struck with the cap as it is blown from the radiator.**

b. If freezing or below freezing ambient temperatures are expected, protect the cooling system by adding antifreeze compound to the radiator. Refer to table 3-2 for the required water-to-antifreeze ratio required at various temperatures.

**NOTE**

Fasten a tag near the radiator filler cap indicating the type antifreeze, and level of protection.

Table 3-2. Freezing Points, Composition, and Specific Gravities of Military Antifreeze Materials

Lowest expected ambient temp. F	Pints inhibited glycol per gal. of coolant <sup>1</sup>	Compound antifreeze Arctic <sup>2</sup>	Ethylene glycol coolant solution specific gravity at 68° F <sup>3</sup>
- 2 0	1 ½	Issued full strength and ready mixed for 0° to -65° F temperatures for both initial installation and replenishment of losses.	1.022
+ 1 0	2		1.036
0	2 ¾		1.047
- 1 0	3 ¼		1.055
- 2 0	3 ½		1.062
- 3 0	4		1.067
- 4 0	4 ¼	DO NOT DILUTE WITH WATER OR ANY OTHER SUBSTANCE.	
- 5 0	Arctic antifreeze preferred		
- 6 0			
- 7 2			

<sup>1</sup>Maximum projection is obtained at 60 percent by volume (4.8 pints of ethylene glycol per gallon of Solution).

<sup>2</sup>Military Specification MIL-C-11755 Arctic type, nonvolatile anti-freeze compound is intended for use in the cooling system of liquid-cooled internal combustion engines. It is used for protection against freezing primarily in Arctic regions where the ambient temperature remains for extended periods close to 40° F, or drops below, to as low as -90° F.

<sup>3</sup>Use an accurate hydrometer. To test hydrometer, use 1 part ethylene glycol antifreeze to 2 parts water. This should produce a hydrometer reading of 0° F.

**3-9. Hand Brake—Minor Adjustment**

a. When slack develops in brake linkage due to lining wear, it may be restored by placing lever in the full release position, and turning the knurled knob on top of the lever several turns clockwise.

b. After making the adjustment, recheck brake action. There should be noticeable tension as the lever passes the over-center position. If necessary, repeat adjustment

NOTE

If brake effectiveness cannot be restored by the above adjustment, a major adjustment or relining of the brake is, required, See Chapter 4.

**3-10. Battery State of Charge Check**

a. Check battery electrolyte level frequently, especially in hot weather. Maintain the level at ½ inch over the top of the plates by adding distilled water, when necessary.

**WARNING**

Never allow sparks or open flame in the area when checking the battery. Storage batteries produce hydrogen, an explosive gas, as a normal by-product of operation.

b. Hydrometer readings should be used to determine the battery state of charge. This is particularly true in cold weather, as a partially discharged battery may freeze at temperatures up to 20° F.

c. Take readings on the hydrometer as shown in figure 3-2. Battery will need charging if the specific gravity reads 1.225 (or less) at 750 F. Correct the hydrometer reading according to the ambient temperature as shown by figure 3-2.

**CAUTION**

**Specific gravity should be 1.265 or greater if battery is exposed to freezing temperatures. If machine is operated in tropical climates where no freezing weather is encountered, the full charge specific gravity may be lowered from 1.375 to 1.225 by diluting the electrolyte with distilled water.**

NOTE

Do not add distilled water to electrolyte immediately after charging the battery.

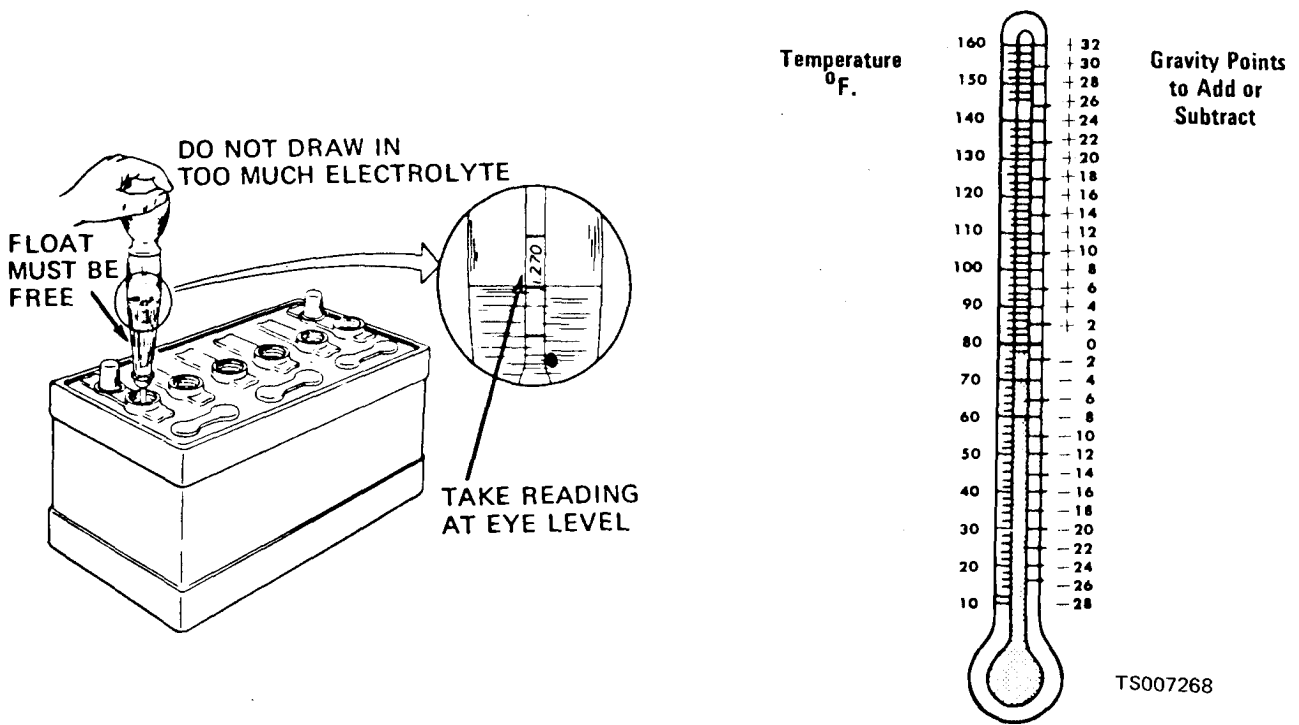

Figure 3-2. Checking Battery Specific Gravity

**3-11. Battery Cables and Terminals**

- a. Check battery cables every 50 hours for good insulation and clean, tight connections.
- b. Remove corrosive deposits from battery terminals by scrubbing with a baking soda or ammonia and water solution.

- c. Good cable connections can be further ensured by cleaning battery posts and cable terminals with a stiff wire brush or cleaning tool.
- d. After cleaning, coat the exterior of the cable terminals and battery posts with a light film of white petroleum jelly to retard further corrosion.

**Section III. TROUBLESHOOTING**

**3-12. General**

a. This section contains troubleshooting information for locating and correcting most of the operating troubles which may develop in the warehouse tractor. Each malfunction for an individual component, unit, or system is followed by a list of tests or inspections which will help you to determine probable causes and corrective

actions to take. You should perform the tests/inspections and corrective actions in the order listed.

b. This manual cannot list all malfunctions that may occur, nor all tests or inspections and corrective actions. If a malfunction is not listed or is not corrected by listed corrective actions, notify your supervisor.

Table 3-3. Troubleshooting

MALFUNCTION	TEST OR INSPECTION	CORRECTIVE ACTION
<b>ENGINE</b>		
1. ENGINE DOES NOT CRANK OR CRANKS VERY SLOWLY WITH KEY SWITCH IN START POSITION.	Step 1. Check to see that transmission range selector is in neutral (N) position.	Place range selector in neutral (N) position.
	Step 2. Check for loose, corroded, or broken battery cables.	Clean corroded cable terminals. Tighten loose connections at battery, ground cable, and starter (para 3-11).
	Step 3. Check electrolyte level in battery, and state of battery charge.	If electrolyte level is below top of plates, add distilled water until the electrolyte level is ½ inch above separators. Recharge battery (para 3-10).
2. ENGINE CRANKS NORMALLY BUT WILL NOT START.	Step 1. Check fuel level.	Replenish fuel supply.
	Step 2. Check for broken or leaking fuel line between tank and carburetor.	Tighten any loose fittings in fuel line. Refer broken or defective fuel lines to organizational maintenance.
3. ENGINE STALLS OR OPERATES ERRATICALLY.	Step 1. Check for dirty or restricted air cleaner.	Refer to organizational maintenance for air cleaner service.
4. ENGINE OVERHEATS.	Step 1. Check coolant level in radiator.	Add coolant as required to bring level to FULL mark (para 3-8).
	Step 2. Check for leaves, trash, or other debris blocking air flow through radiator.	Clean area around radiator core and grillwork. Steam cleaning of core is recommended.
<b>HAND BRAKE</b>		
1. PARKING BRAKE DOES NOT HOLD TRACTOR ON A GRADE.	Step 1. Check for loss of tension in brake linkage with lever in applied position.	Perform minor adjustment (para 3-9).
<b>WHEELS AND TIRES</b>		
1. STEERING DIFFICULT, TRACTOR PULLS TO ONE SIDE.	Step 1. Check for low air pressure in one or more tires.	Inflate all tires to proper pressure, as marked above wheel well.
	Step 2. Check to see that proper size and type of tires are mounted.	Refer to organizational maintenance for tire replacement.
2. WHEEL WOBBLE.	Step 1. Check to see that all wheel mounting nuts are tight.	Tighten any loose nuts.
	Step 2. Inspect wheel for bent or damaged rim.	Refer to organizational maintenance for wheel replacement.



## CHAPTER 4

## ORGANIZATIONAL MAINTENANCE INSTRUCTIONS

## Section I. SERVICE UPON RECEIPT OF MATERIEL

**4-1. Inspecting and Servicing the Equipment**

When a new or reconditioned vehicle is first received by the using organization, it is necessary to determine that the vehicle is in satisfactory condition and will operate properly when first placed into service. For this reason, follow closely the service procedures outlined in the following paragraphs.

**4-2. Preliminary Inspection**

Visually inspect the vehicle upon receipt for obvious damage, such as broken, cracked, dented or missing parts. Carefully check pintle hook in particular, for secure mounting, and proper operation. Report any damage, errors or discrepancies on the appropriate forms.

**4-3. Preliminary Checks and Services**

*a. Engine Coolant Level.* Remove radiator cap. Check to see that coolant level reaches the full mark, or approximately 1 inch below the top of the filler neck.

## CAUTION

**If ambient temperature drops below 32° F, also check level of antifreeze protection by testing coolant with a hydrometer.**

*b. Fuel Level.* Remove fuel filler cap and strainer, or check instrument panel gage reading with ignition switch ON.

## NOTE

If vehicle has been shipped with a preservative in the fuel tank, a prominent tag will be attached to the machine indicating this fact. Drain the fuel tank of preservative by removing drain plug directly underneath the tank.

*c. Engine Oil Level.* Open the engine hood and remove the dipstick oil gage which is located just forward of the distributor on the left side of the engine. Check oil level on dipstick to ensure that it reaches the FULL mark.

*d. Transmission Fluid Level.* Transmission fluid level should be checked with the transmission warm, in neutral range, and the engine running. The transmission dipstick gage is

located in the engine compartment, on the right side, just forward of the firewall.

*e. Master Cylinder Brake Fluid Level.* Remove master cylinder filler cap and check fluid level, which should be maintained at about ¼ inch below the top of the reservoir.

*f. Battery Water Level and State of Charge.* Remove filler caps on the battery and check water level, which must cover plates at least ½ inch. Check state of charge with a hydrometer. (See paragraph 3-9.)

**WARNING**

**Do not smoke, weld, or employ any open flame near the battery, as an explosive gas is produced by the battery during its operation.**

*g. Switches, Gages, and Lights.* Check operation of neutral start switch by placing direction selector in forward or reverse position and turning ignition switch to START position. Starter must not engage until direction selector is returned to NEUTRAL position.

(1) Start engine and check hourmeter, temperature gages, oil pressure gage, ammeter, and fuel level gage for proper operation.

(2) Turn light switch ON and check to see that headlight and taillight are both operable. Check operation of horn by depressing center button in steering wheel.

**4-4. Operational Check**

Refer to operating instructions in Chapter 2 and check operation of engine, transmission, and brakes. Check that parking brake will prevent truck motion with transmission in gear and engine at full power.

**4-5. Lubrication**

Check machine record or service tags for indication of last periodic maintenance performance. If necessary, service the vehicle in accordance with the Lubrication Order LO 10-3930-633-12, using proper weight of lubricant for the prevailing climatic conditions.

## Section II. MOVEMENT TO A NEW WORKSITE

### 4-6. General

*a.* For short-distance movement over hard surfaces within the confines of a government installation, the tractor may be driven directly to the new site. Make certain enough fuel is carried to complete the trip.

*b.* For transportation from one installation to another, over public highways or any long distance, the tractor may be carried by flat-bed

trailer or shipped by rail. Appropriate tiedowns are indicated on the shipping data plate. Make certain that a copy of this manual, and appropriate maintenance records, are shipped with each vehicle.

*c.* Disconnect the battery ground cable prior to rail or trailer shipment, to discourage unauthorized tampering with the equipment during shipment.

## Section III. REPAIR PARTS, SPECIAL TOOLS, AND EQUIPMENT

### 4-7. Tools and Equipment

No special tools or equipment are issued to organizational level maintenance for use with the warehouse. tractor.

### 4-8. Special Tools and Equipment

No special tools or equipment are required in the performance of organizational maintenance functions.

### 4-9. Maintenance Repair Parts

Repair parts and equipment are listed and illustrated in the repair-parts and special tools list covering organizational maintenance for this equipment, TM 10-3930-633-20P.

## Section IV. LUBRICATION INSTRUCTIONS

### 4-10. General

*a.* Refer to Lubrication Order LO 10-3930-633-12 for all lubrication procedures authorized at organizational level. Supplementary instructions to the Lubrication Order are contained in the following paragraphs.

*b.* Use only the lubricants specified in the lubrication order. Carefully follow instructions given on the lubrication order to assure proper operation of the equipment.

### 4-11. Detailed Lubrication Information

*a. General.* Keep all lubricants in closed containers and store in a clean, dry place away from external heat, Allow no dust, dirt, or other foreign material to mix with the lubricants. Keep all lubrication equipment clean and ready for use.

*b. Cleaning.* Keep all external parts not requiring lubrication clean of "lubricants. Before lubricating the equipment, wipe all lubrication points free of dirt and grease. Clean all lubrication points after lubrication to prevent accumulation of foreign matter.

*c. Points of Lubrication.* Service the

lubrication points at proper intervals as illustrated in the lubrication order.

### 4-12. Rear Axle and Gearcase Drain and Refill

*a. Drain.* The rear axle and gearcase should be drained while hot from recent operation. Remove drain plugs in differential case and gearcase and allow oil to drain completely. Make certain that tractor is on a level surface, so that housings will drain completely.

*b. Refill.* The differential housing and transfer case are refilled through the filler plugs located on the side of each housing. The proper fill level is just up to the lower edge of the filler plug hole. Use the proper weight of oil for the anticipated ambient temperatures of operation and storage (Refer to LO 10-3930-633-12).

### 4-13. Wheel Bearings Repack

*a. Removal.*

(1) When removing rear tire and wheel assemblies, it is only necessary to raise the rear wheels off the ground by means of a jack or hoist, and remove the wheel mounting nuts.

(2) When removing front wheels, make certain that all air pressure is relieved, then proceed to remove the wheel by removing *ONLY* the inner set of nuts as shown in figure 4-42. Do not disturb the nuts on the larger bolt circle (nearer the rim).

**WARNING**

**Never remove front wheels and tires without first completely deflating the tire. Remove the valve core to make certain that all pressure is exhausted. Deflating prior to removal is recommended for rear tires also.**

*b. Lubrication.* Every 1000 hours, remove wheels, grease caps, rear axle shafts and brake drums to expose wheel bearings refer to figure 4-42. Thoroughly clean out bearings and recesses in brake drums to remove all traces of old grease. Bearing cones may be rinsed in Solvent, Federal Specification P-D-680, and allowed to air dry. Do not spin bearings dry with compressed air. Repack bearing cones and hub recesses with the proper grease as specified in the Lubrication Order LO 10-3930-633-12. Refer to figure 4-1 for proper packing of grease inside hubs.

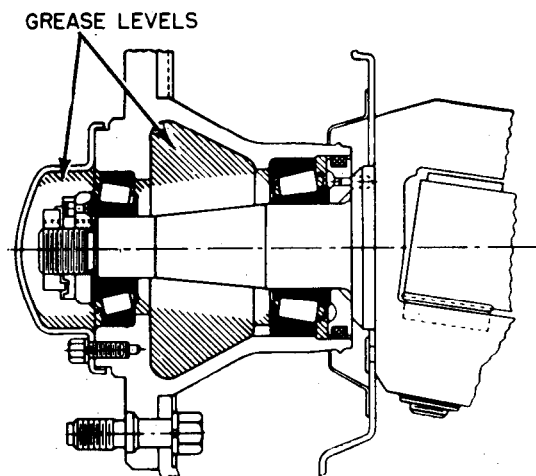

THE SHADING IN EACH INDICATES THE RECOMMENDATION FOR THE CORRECT AMOUNT OF GREASE.

TS007269

Figure 4-1. Repacking Wheel Hubs and Bearings

**4-13.1. Engine Crankcase Oil and Filter Change**

*a. Oil Drain.* Engine crankcase oil should be drained while hot, preferably immediately after running. Remove the drain **plug** in the oil pan and allow pan to drain completely. Make certain that tractor is on a level surface, so that pan will drain properly.

*b. Filter Replacement.* Refer to figure 4-1.1, and unscrew and remove engine oil filter cartridge. Discard old cartridge and gasket. Wipe off the base of the filter adapter with a clean cloth. Coat the new filter gasket (furnished with filter) with clean engine oil, and thread the cartridge up on the adapter until the gasket contacts the base, then tighten 1/2 turn further.

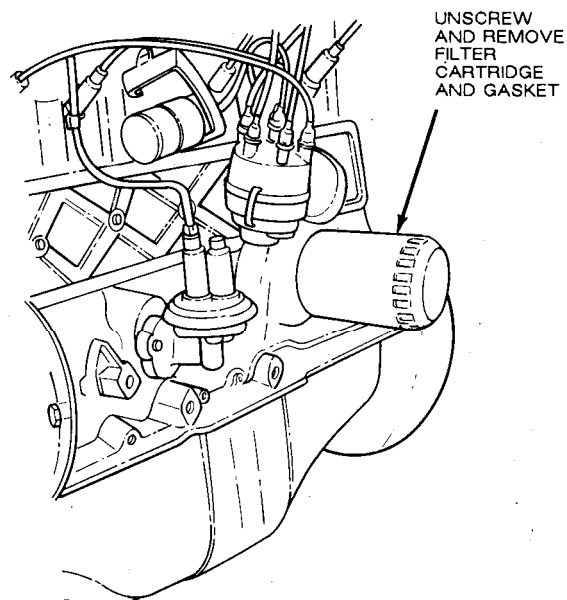

TA501870

Figure 4-1.1. Engine Oil Filter

*c. Oil Fill.* Install crankcase drain plug. Remove filler cap and pour 5 quarts of oil of the recommended weight (see lubrication order) in the rocker arm cover hole. Start the engine and check for leakage at the filter cartridge flange; tighten cartridge if leakage occurs. Check oil level on the dipstick, and add sufficient oil to bring level to FULL mark. Replace filler cap.

**4-13.2. Transmission Oil Change**

*a. Transmission Drain.*

(1) Place a drain pan under the transmission oil pan.

(2) Starting at the rear of the pan, working toward the front, loosen the attaching bolts and allow the fluid to drain from the pan.

(3) After most of the fluid has drained, remove the remainder of the attaching bolts. Unscrew and remove transmission oil filter shown in figure 4-1.2.

(4) Remove the pan, then remove the fluid filter and clip from the transmission. Clean the inside of the pan. Remove all gasket material from the pan and pan mounting face on the transmission case.

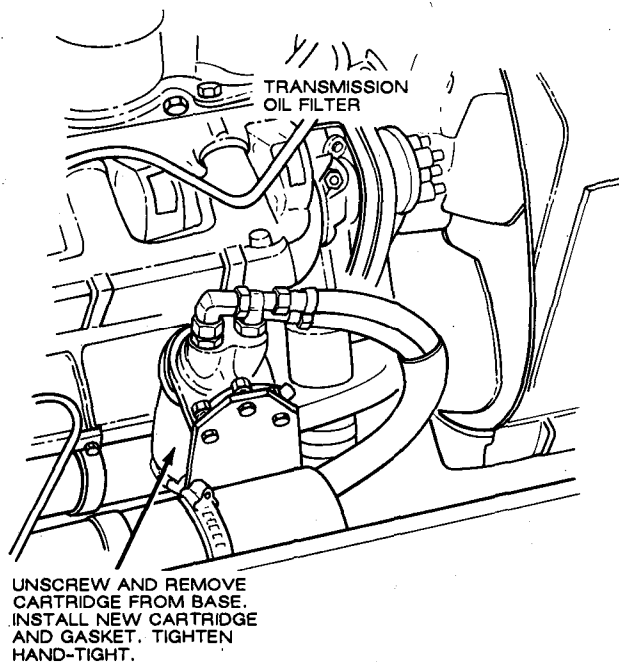

TA501871

Figure 4-1.2. Transmission Oil Filter

(5) Install the transmission fluid filter and clip. Install the oil pan, using a new gasket,

*b. Filter Replacement.*

(1) The filter is a throw-away element type, mounted to a bracket on the right side of the engine compartment.

(2) Unscrew and discard the old element.

(3) Fill the new element with clean fluid. Make sure the rubber sealing ring is in place and screw the new cartridge on the adapter until it just makes contact, then tighten 1/2 turn farther.

*c. Transmission Refill.*

(1) Refill the transmission with 8 quarts of transmission fluid, Type "F" (Ford Motor Co. Specification M2C-33F or equivalent).

(2) Start the engine and allow transmission to warm up thoroughly, then check fluid level on transmission dipstick. Add sufficient fluid to bring level to FULL mark on dipstick. Complete transmission refill, including converter, requires 11 quarts of fluid.

**Section V. PREVENTIVE MAINTENANCE CHECKS AND SERVICES  
(MONTHLY AND QUARTERLY)**

**4-14. General**

Preventive Maintenance Checks and Services to be performed at monthly or quarterly intervals are detailed in table 4-1. All deficiencies and

shortcomings, together with the corrective action taken, will be noted on DA Form 2404 (Equipment Inspection and Maintenance Worksheet) at the earliest opportunity.



Table 4-1. Organizational Preventive Maintenance Checks and Services

M = Monthly

Q= Quarterly

Interval and Sequence No.	Item to be Inspected Procedure	Work (M/H)
1	<p><b>1 HOOD AND PANELS</b>                      Check hood and panels for physical damage: dents, corrosion, cracks or tears in sheet metal, etc. Refer to Section VIII for repair.                      Check opening and closing of hood. Align hood at hinges if required and lubricate hinges and latch mechanism as required.</p>	1.0
	<p><b>2 LIGHTS</b>                      Check all lights for cracked or broken lenses and burned-out condition. Refer to Section IX for replacement of bulbs or lenses, Also check for secure mounting and condition of wiring.</p>	0.4
2	<p><b>FUEL PUMP</b>                      Perform fuel pump static pressure and volume test as outlined in Section X, if pump performance is suspect.</p>	1.0
	<p><b>3</b>                      Replace fuel filter element.</p>	0.3
3	<p><b>4 AIR CLEANER</b>                      Service the air cleaner element and empty the dust cup. Element may be cleaned by compressed air or by washing. Refer to Section X for specific instructions.</p>	0.2
	<p><b>5</b>                      Check air intake system of hoses and tubes to carburetor for loose connections or damaged hose. Replace defective hose and tighten connections.</p>	0.2
4	<p><b>6 CARBURETOR</b>                      Perform idle speed and mixture adjustments as outlined in Section X.</p>	0.3
	<p><b>7</b>                      Check carburetor for evidence of fuel leakage at gaskets and connections, and refer to direct support maintenance for repair.</p>	0.5
5	<p><b>8 G O V E R N O R</b>                      Check operation of governor as outlined in Section X. Adjust governor if engine speed is outside the normal operating range as stamped on the governor case.</p>	0.4
	<p><b>9 COOLING SYSTEM</b>                      Carefully inspect radiator hoses for leakage, deterioration and mushy feeling, swelling around the clamps, etc. Replace all defective hose and clamps.</p>	0.5
6	<p><b>10</b>                      Check operation of thermostat while warming a cold engine. Replace thermostat if it does not operate as specified in Section XII.</p>	0.5
	<p><b>11</b>                      Check fan belt condition and adjustment. Replace worn belts and adjust to proper tension as specified in Section XII.</p>	0.2
7	<p><b>12</b>                      Check water pump for leakage around pulley bearing or at gasket surface. Check bearing wear by attempting to wobble the fan. If perceptible shake exists, replace water pump.</p>	1.0
	<p><b>13</b>                      Check radiator for visible signs of leakage in core. Pressure test radiator and cooling system.</p>	1.5
8	<p><b>14 ELECTRICAL SYSTEM</b>                      Check alternator belt tension, and adjust to permit ¼ to ½ inch deflection with 25 lb force applied at midpoint of belt.</p>	0.2
	<p><b>15</b>                      Check alternator output in accordance with instructions in Section IX.</p>	0.5
9	<p><b>16</b>                      Test voltage regulator operation and adjust or replace as required.</p>	0.5
	<p><b>17</b>                      Check operation of starter and solenoid switch. Replace defective parts.</p>	0.5
10	<p><b>18 DISTRIBUTOR</b>                      Check ignition timing and adjust distributor as required.</p>	0.2
	<p><b>19</b>                      Check and adjust contact points.</p>	0.3
11	<p><b>20</b>                      Check centrifugal and vacuum advance mechanisms.</p>	0.5
	<p><b>21 COIL</b>                      Check operation of ignition coil and check primary and secondary ignition wiring for deterioration and current leakage.</p>	0.3
12	<p><b>22 SPARK PLUGS</b>                      Check condition of individual spark plugs. Clean, or replace plugs, and adjust to proper gap.</p>	0.4
	<p><b>23 BATTERY</b>                      Test battery to determine cell condition. Recharge or replace battery as required.</p>	0.3

M = Monthly

Q = Quarterly

Interval and Sequence No.		Item to be Inspected Procedure	Work Time (M H)
M	Q		
7	25	<b>GAGES AND SWITCHES</b> Check all gages and switches for proper operation. Check for cracked or broken glass on face of gages. Check condition of wiring to all gages, sending units, and switches. Replace any defective item.	0.6
8	26	<b>ENGINE</b> Change oil and filter as outlined in Chapter 3. Clean crankcase breather. Check for evidence of oil or water leakage at head and manifold gaskets.	0.3
	27	Check closely around cylinder head and block mounting surfaces for evidence of gasket leaks, or cracks in the cylinder head. Check cylinder head mounting bolt torque and correct as required. See Section XIII for procedure.	0.5
	28	Adjust valve lash.	1.0
	29	<b>TRANSMISSION</b> Change transmission fluid and filter as outlined in Chapter 3. Check transmission operation in all ranges.	0.5
	30	<b>PROPELLER SHAFT</b> Lubricate at fitting on splined shaft. Check for excessive play in shaft, indicating substantial bearing wear and need for universal joint replacement.	0.2
	31	<b>WHEEL BEARINGS</b> Check, adjust, and repack wheel bearings every six months or 1000 operating hours. Refer to Section XIV for applicable procedures.	1.0
9	32	<b>BRAKES</b> Check brake operation and adjust linings as required. If linings are worn, refer to direct support for relining.	1.0
	33	Inspect brake lines and wheel cylinders for evidence of leakage.	0.4
10	34	Check master cylinder and power booster operation. Check fluid level in master cylinder and add fluid as required.	0.2
	35	Bleed the brake system if pedal feels spongy, or if brake system has been opened up at any point.	0.4
11	36	<b>HAND BRAKE</b> Check ability of hand brake to hold tractor on a grade. Adjust lining clearance to compensate for wear, or, if linings appear worn, perform complete relining as outlined in Section XV.	1.0
	37	<b>REAR AXLE</b> Drain and refill rear axle differential and drop gear case. Check for leakage around differential housing and axle ends.	0.4
	38	<b>STEERING SYSTEM</b> Perform all lubrication services on drag link and tie rod. Check condition of drag link, particularly the ball stud seats, and replace worn parts.	1.0
	39	Check steering gear adjustment and correct if necessary, according to instructions of Section XVI.	0.2
	40	<b>FRONT AXLE</b> Lubricate front axle king pins. Check for bent or misaligned axle. Check security of mounting to springs.	0.2
	41	<b>SPRINGS</b> Check springs for broken leaves, loose clips or hardware, and security of mounting at spring shackles.	0.1
	42	<b>PINTLE HOOK</b> Check pintle hook for security of mounting. Check to see that hook latches and unlatches properly. Replace entire assembly if defective.	0.5

## Section VI. TROUBLESHOOTING

### 4-15. General

a. This section contains troubleshooting information for locating and correcting most of the operating troubles which may develop in the warehouse tractor. Each malfunction for an in-

dividual component, unit, or system is followed by a list of tests or inspections which will aid in determining probable causes and corrective actions to take. Perform these tests/inspections and corrective actions in the order listed.

b. This manual cannot list all malfunctions that may occur, nor all tests or inspections and corrective actions. If a malfunction is not listed or

is not corrected by the listed corrective actions, notify your supervisor.

Table 4-2. Troubleshooting

MALFUNCTION	TEST OR INSPECTION	CORRECTIVE ACTION
<b>FUEL SYSTEM</b>		
1. FUEL NOT REACHING CARBURETOR.	Step 1. Check fuel level in tank, also check for dirt or sediment in bottom of tank. Drain and/or refill fuel tank.	
	Step 2. Check for damaged or leaky fuel lines between fuel tank and carburetor. Repair or replace damaged fuel lines (para 4-48).	
	Step 3. Check fuel filter element for obstruction. Replace fuel filter (para 4-51).	
	Step 4. Check to see if fuel pump is delivering sufficient fuel. Replace fuel pump (para 4-52).	
2. CARBURETOR NOT DELIVERING PROPER MIXTURE.	Step 1. Check for improper choke adjustment. Adjust to provide full opening with choke control pushed fully in.	
	Step 2. Remove carburetor and check for stuck float or blocked fuel passage. Replace carburetor (para 4-39).	
3. HIGH FUEL CONSUMPTION.	Step 1. Check carburetor adjustment. Adjust carburetor to specifications (para 4-57).	
	Step 2. Check governor adjustment. Adjust governor to specifications (para 4-59).	
	Step 3. Check fuel lines for leakage. Replace or tighten leaky fuel lines (para 4-48).	
	Step 4. Check engine operating temperature; overheated engine will use excessive fuel. Refer to cooling system tests (para 4-64).	
	Step 5. Check engine timing. Correct timing to specifications (para 4-38).	
	Step 6. Check for weak spark. Refer to ignition system tests (para 4-30).	
<b>COOLING SYSTEM</b>		
1. LOSS OF COOLANT.	Step 1. Check for leaks at radiator and hose connections. Replace defective hoses, tighten loose clamps (para 4-64).	
	Step 2. Check for engine overheating, causing after boil. Refer to engine overheating tests and inspections.	
	Step 3. Check for leakage at water pump. Replace leaking water pump.	
	Step 4. Check for evidence of water in engine crankcase, indicating cracked cylinder head or blown head gasket. Replace cylinder head and gasket.	
	Step 5. Check for evidence of water in transmission fluid, indicating a leak in the oil cooler. Replace radiator.	
2. ENGINE OVERHEATS.	Step 1. Check coolant level. Fill radiator to proper level.	
	Step 2. Check for broken or loose fan belt. Tighten or replace fan belt.	
	Step 3. Check radiator for obstruction. Clean away obstruction; steam clean radiator core.	
	Step 4. Check for proper coolant flow through radiator. Pressure flush radiator to clear obstructions. Replace thermostat, if sticking.	
	Step 5. Check ignition timing. Set timing to specifications (para 4-38).	
	Step 6. Check water pump for broken impeller. Replace water pump (para 4-65).	
	Step 7. Check for restricted air cleaner. Replace air cleaner element, clear obstruction from air intake system (para 4-54).	
	Step 8. Check for bent or clogged exhaust pipe or muffler, creating excessive back pressure. Replace damaged parts (para 4-62).	



## MALFUNCTION

## TEST OR INSPECTION

## CORRECTIVE ACTION

## 3. ENGINE RUNNING TOO COOL.

Step 1. Check operation of thermostat in restricting cold water flow through radiator.

Replace stuck thermostat.

Step 2. Check to determine if overcooking is the result of extended outside operation in low ambient temperatures.

Cover part of radiator core to obstruct air flow.

## ELECTRICAL SYSTEM

## 1. BATTERY WEAK OR FAILS TO MAINTAIN CHARGE.

Step 1. Check battery electrolyte level.

Add distilled water to cover plates to ½ inch, check for cracked case and replace battery if cracks are found.

Step 2. Check for shorted cell in battery.

Replace battery.

Step 3. Check alternator belt tension and output.

Tighten alternator belt tension. Replace alternator if output is low and regulator adjustment does not correct.

Step 4. Check voltage regulator adjustment (para 4-28).

Adjust regulator to specifications. Replace regulator if adjustment cannot be maintained.

Step 5. Check for excessive use of starter or dragging starter resulting in excessive battery drain.

Tune engine for easy starting or replace a dragging starter.

Step 6. Check for short to ground in electrical wiring.

Correct short condition.

## 2. STARTER CRANKS ENGINE SLOWLY.

Step 1. Check state of battery charge.

Refer to Item 1, "BATTERY WEAK."

Step 2. Check for loose or corroded battery cable terminals.

Clean and tighten battery cable terminals.

Step 3. Check for excessive amperage draw within starting motor.

Replace starter (para 4-29).

## 3. STARTER WILL NOT CRANK ENGINE.

Step 1. Check for loose, corroded, or broken cables to starting motor and solenoid switch.

Replace defective cables. Clean and tighten all cable terminals.

Step 2. Make certain that transmission shifter is in Neutral (N) position.

Place shifter in Neutral (N) position.

Step 3. Check make-and-break action of neutral start switch using ohmmeter.

Replace defective switch.

Step 4. Test starter for defects.

Replace defective starter.

Step 5. Check starter mounting; if loose, starter pinion may not engage flywheel.

Tighten starter mounting bolts.

## IGNITION SYSTEM

## 1. ENGINE WILL NOT START.

Step 1. Check for spark at plugs; if no spark at plugs, check the following:

Step 2. Check ignition coil for shorts or grounds.

Replace ignition coil (para 4-40).

Step 3. Check distributor points adjustment and condition.

Adjust or replace points (para 4-34).

Step 4. Check capacitor for open circuit.

Replace capacitor.

Step 5. Examine rotor and distributor cap for cracks, burned areas, corrosion, and carbon tracking.

Replace defective rotor and distributor cap (para 4-34).

Step 6. Check for leakage in high-tension wires due to dampness.

Replace faulty wiring (para 4-32).

Step 7. Check spark plug gap setting.

Adjust gaps to specifications (para 4-31).

## 2. ENGINE RUNS ROUGH OR MISSES.

Step 1. Check ignition timing.

Adjust timing to specifications (para 4-38).

Step 2. Check to see that all high-tension wire terminals are tight at distributor and at plugs.

Tighten connections or replace faulty wiring.

Step 3. Check distributor advance mechanism (para 4-39).

Replace distribution if advance mechanism malfunctions.

Step 4. Check that high-tension wires are routed to proper plugs in firing order.

Disconnect wires and reinstall properly (para 4-32).

Step 5. Check for one or more defective spark plug.

Replace defective plugs (para 4-31).

---

MALFUNCTION

TEST OR INSPECTION

CORRECTIVE ACTION

---

3. ENGINE PINGS OR KNOCKS UNDER LOAD.

- Step 1. Check for proper ignition timing.  
Adjust timing to specifications.
- Step 2. Check operation advance mechanism.  
Replace distributor if advance mechanism malfunctions.

ENGINE

1. ENGINE WILL NOT START.

- Step 1. Perform checks under "FUEL SYSTEM."
- Step 2. Perform checks under "IGNITION SYSTEM."
- Step 3. Check for low compression.

Refer to direct support maintenance.

2. ENGINE BACKFIRES, MISSES, OR OPERATES ERRATICALLY.

- Step 1. Check malfunctions under "IGNITION SYSTEM."
- Step 2. Check for intake manifold leak and partial loss of engine vacuum.  
Tighten intake manifold bolts, or replace intake manifold.
- Step 3. Check for blown head gasket (compression check).  
Replace head gasket (para 4-72).
- Step 4. Check for sticking valve (vacuum or compression check).  
Refer to direct support maintenance.

Step 5. Check for excessive carbon build-up in cylinder head.

Replace cylinder head (para 4-72).

3. ENGINE STALLS OR VERY ROUGH AT IDLE.

- Step 1. Check malfunctions under "IGNITION SYSTEM."
- Step 2. Check malfunctions under "FUEL SYSTEM."
- Step 3. Run a compression check for sticking valve or blown head gasket.  
Replace cylinder head and gasket (para 4-72).
- Step 4. Check for intake manifold leaks.  
Tighten intake manifold bolts; replace gasket; replace cylinder head (para 4-72).

4. ENGINE LACKS POWER.

- Step 1. Check malfunctions under "FUEL SYSTEM."
- Step 2. Check malfunctions under "IGNITION SYSTEM."
- Step 3. Run a compression check to locate sticking valve, worn rings, or blown head gasket.  
Replace cylinder head and gasket; refer worn rings to direct support or general support maintenance.

- Step 4. Check for bent or obstructed muffler or tailpipe.  
Repair or replace exhaust pipe or muffler (para 4-62).

5. HIGH OIL CONSUMPTION.

- Step 1. Check for oil leaks at pan, gasket surfaces or crankshaft main seals.  
Replace pan gaskets. Refer leaking seals to direct or general support maintenance.
- Step 2. Check for improper grade and type of oil.  
Drain and refill with proper grade and type of oil (LO 10-3930-633-12).
- Step 3. Check for engine overheating; causing thinning of oil.  
Refer to "COOLING SYSTEM" for causes of overheating.
- Step 4. Perform compression check to determine if rings and valve guides are excessively worn.  
Refer worn engine to direct or general support maintenance.

6. LOW OR NO OIL PRESSURE.

- Step 1. Check oil level.  
Fill crankcase with proper quantity and type of oil (LO 10-3930-633-12).
- Step 2. Check for oil leakage at cylinder head, crankshaft main seals, or timing chain cover.  
Refer to direct or general support maintenance.

TRANSMISSION

1. TRANSMISSION WILL NOT ENGAGE.

- Step 1. Check fluid level.  
Refill with proper fluid (LO 10-3930-633-12).
- Step 2. Check to see if control cable has become disconnected.  
Reconnect control cable at selector or transmission.

2. TRANSMISSION OPERATES ERRATICALLY.

- Step 1. Check for low fluid level.  
Refill with proper fluid (LO 10-3930-633-12).
- Step 2. Check for fluid foaming due to overfilling.  
Drain level back to FULL mark on dipstick.

3. TRANSMISSION FLUID OVERHEATS.

- Step 1. Check for dragging parking brake or service brake.  
Adjust brakes to eliminate drag (para. 4-79).

---

**MALFUNCTION****TEST OR INSPECTION****CORRECTIVE ACTION**

---

Step 2. Check for overheated cooling system.

Perform tests and corrective actions listed under "COOLING SYSTEM."

Step 3. Check for constant, low speed, overloaded operation.

Reduce vehicle loading.

**BRAKES****1. POOR BRAKE ACTION, HIGH PEDAL PRESSURE REQUIRED.**

Step 1. Check fluid level in master cylinder.

Fill master cylinder reservoir to within ¼ inch of filler neck.

Step 2. Check for leaks in vacuum line to booster.

Tighten or replace vacuum line.

Step 3. Check for grease on brake linings.

Replace defective grease seal; refer to direct or general support maintenance for brake reline.

Step 4. Check for excessively worn or glazed lining.

Refer to direct or general support maintenance for brake reline.

Step 5. Check for leakage in hydraulic lines to wheel cylinders or master cylinder.

Correct leaks, replace lines and fittings as required.

**REAR AXLE****1. CONTINUOUS NOISE FROM AXLE.**

Step 1. Check for low lubricant level.

Refill to proper level (para 4-84).

Step 2. Check for uneven tire sizes or pressure.

Install correct tire size and inflate to proper pressure (45 PSI).

Step 3. Check rear wheel bearings for wear.

Adjust or replace wheel bearings as required (para 4-75).

Step 4. Check for loose mounting bolts around differential mounting or reduction gearcase.

Tighten loose mounting bolts.

**2. NOISE FROM AXLE ON TURNS ONLY.**

Step 1. Check adjustment of rear wheel bearings.

Adjust rear wheel bearings as required (para 4-75).

Step 2. Refer internal axle malfunctions to direct or general support maintenance.

**STEERING****1. STEERING REQUIRES EXCESSIVE EFFORT.**

Step 1. Check for low air pressure in tires.

Inflate tires to proper air pressure (45 PSI rear, 100 PSI front).

Step 2. Check for stiffness in tie rod ends, steering knuckles and steering gear due to lack of lubrication.

Lubricate all items in accordance with LO 10-3930-633-12.

Step 3. Check for bent or misaligned tie rod or drag link.

Replace damaged drag link. Refer damaged tie rod to direct or general support maintenance.

**2. TRACTOR WANDERS OR WEAVES.**

Step 1. Check front wheel toe-in.

Adjust to specifications.

Step 2. Check for loose drag link connections.

Tighten drag link half stud ends to eliminate play in steering linkage.

Step 3. Check for excessive play in front wheel bearings.

Adjust front wheel bearings to specifications.

Step 4. Check for steering gear out of adjustment.

Adjust steering gear to specifications (para 4-87).

Step 5. Check for loose steering gear mounting bolts.

Tighten all steering gear mounting bolts.

**3. NOTICEABLE PULL TO ONE SIDE.**

Step 1. Check front tires for mismatch, or low air pressure.

Install tires of same size on both wheels. Inflate to 100 PSI (front wheels).

Step 2. Check wheel bearings for tight adjustment.

Adjust wheel bearings to eliminate binding (para 4-75).

Step 3. Check for dragging brake shoe on one side.

Adjust brake to eliminate shoe drag (para 4-79).

Step 4. Refer other defects to direct or general support maintenance.

---

Section VII. RADIO INTERFERENCE SUPPRESSION

**4-16. General Methods Used to Attain Proper Suppression**

Essentially, suppression is attained by providing a low resistance path to ground for stray currents. The methods used include shielding the ignition and high-frequency wires, grounding the frame with bonding straps, and using capacitors and resistors.

**4-17. Interference Suppression Components.**

*a. Primary Suppression Components.* The primary suppression components are those whose primary function is to suppress radio interference. These components are described and located in figure 4-2.

*b. Secondary Suppression Components.* These components have radio interference suppression functions which are incidental or secondary to their primary functions.

**4-18. Replacement of Suppression Components**  
Refer to figure 4-2 for details on replacement of primary suppression components.

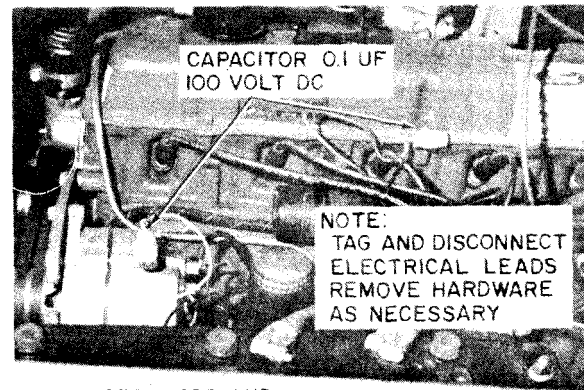
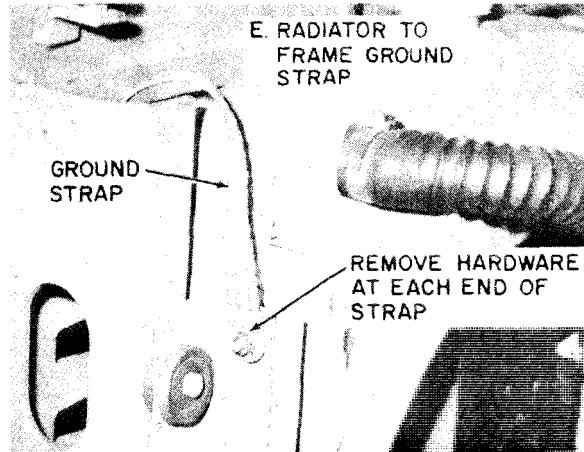

A. ALTERNATOR AND COIL CAPACITOR

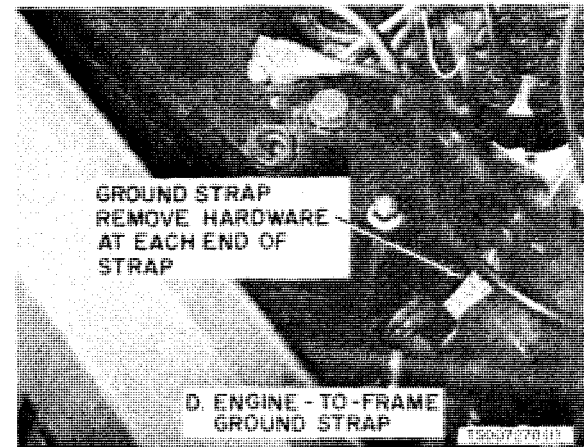

Figure 4-2. Interference Suppression Components, Sheet 1 of 2

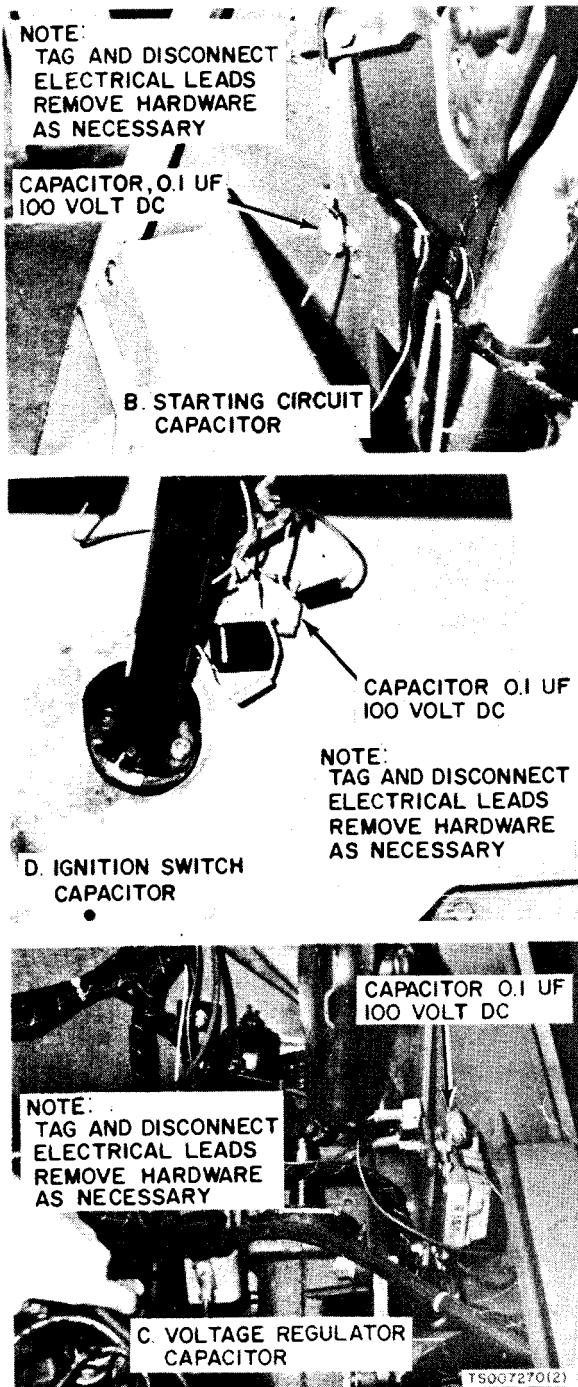

Figure 4-2. Interference Suppression Components, Sheet 2 of 2

#### 4-19. Testing of Radio Interference Suppression Components

Test the capacitors for leaks and shorts on a capacitor tester; replace defective capacitors. If test equipment is not available and interference is indicated, isolate the cause of interference by the trial-and-error method of replacing each capacitor in turn until the cause of interference is located and eliminated.

### Section VIII. MAINTENANCE OF BODY

#### 4-20. General

a. The vehicle frame is of unitized welded construction, and incorporates the frame and the body. The frame is fabricated of heavy steel plate, providing sufficient weight and strength to carry

all the anticipated stresses of the power train and towed loads. This frame unit provides mounting facilities for the engine, transmission, front and rear axles, and all controls and instruments. A cast iron counterweight is mounted on the rear of

the frame, over the rear axle, to increase traction of the drive axle.

b. The remainder of the body consists of the engine hood and side panels, firewall and cowling, floor plates, and the rear deck cover. These parts are all formed of heavy-gauge sheet metal, and are assembled to the frame in the relationship depicted in figure 4-3.

KEY to fig. 4-3:

1. Latch
2. Bolt
3. Washer
4. Spring
5. Hood
6. Bolt
7. Washer
8. Lockwasher
9. RH Panel
10. LH Panel
11. Bolt
12. Bolt
13. Washer
14. Washer
15. Lockwasher
16. Nut
17. Bolt
18. Lockwasher
19. Washer
20. Bumper
21. Nut
22. RH Hinge
23. LH Hinge
24. Bolt

25. Lockwasher
26. Washer
27. Spring
28. Cowl
29. Bolt
30. Lockwasher
31. Washer
32. Seal
33. Shield
34. Bolt
35. Lockwasher
36. Washer
37. Nut
38. Floor plate
39. Bolt
40. Lockwasher
41. Washer
42. Cover
43. Bolt
44. Lockwasher
45. Washer
46. Bracket
47. Bolt
48. Lockwasher
49. Washer
50. Counterweight
51. Bolt
52. Lockwasher
53. Washer
54. Nut
55. Counterweight
56. Bolt
57. Washer
58. Lockwasher
59. Nut
60. Frame

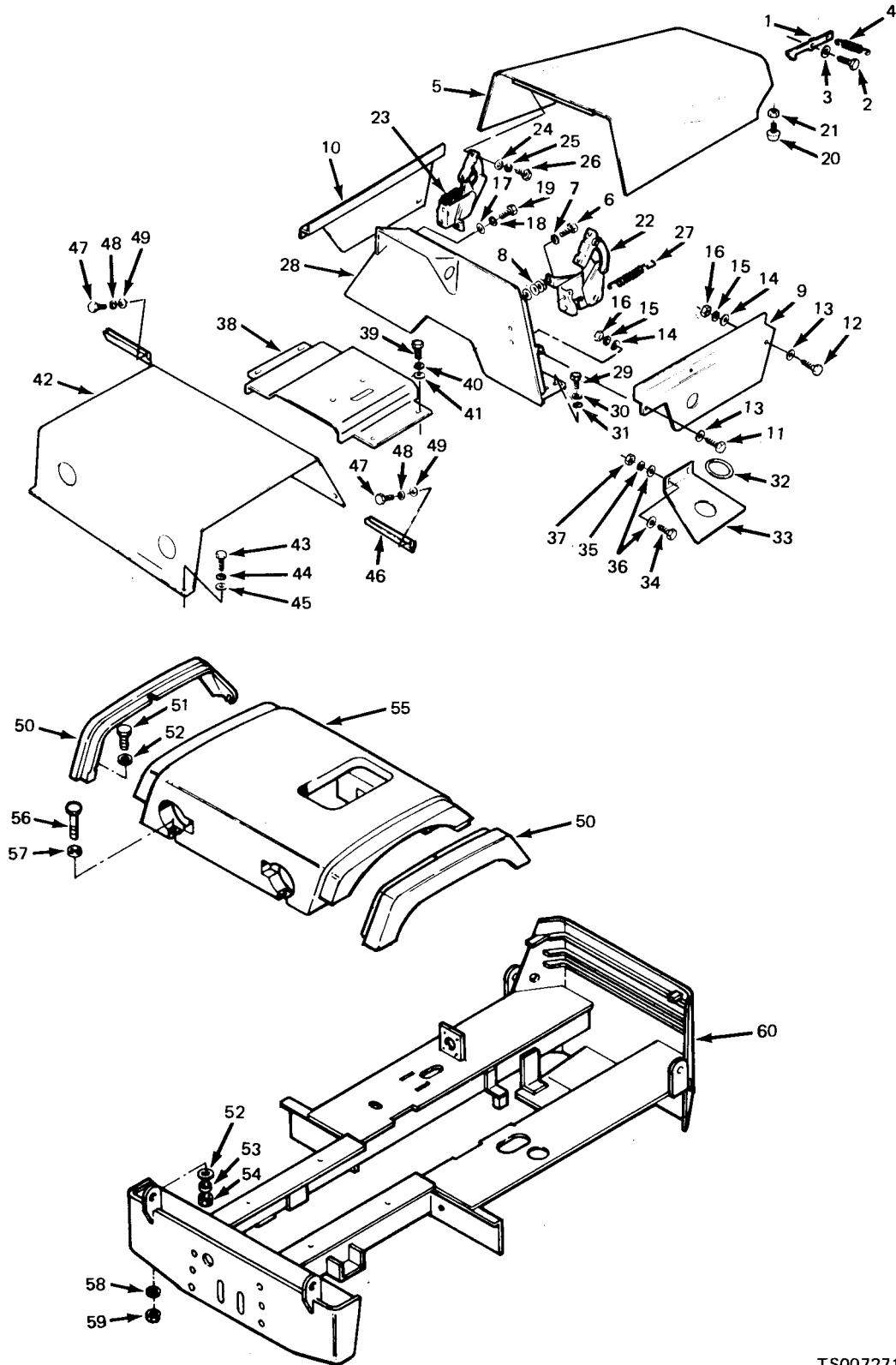

TS007271

Figure 4-3. Frame and Sheet Metal

#### 4-21. Inspection

a. During the quarterly preventive maintenance inspection, all body and frame sheet metal and welded parts should be thoroughly inspected for physical damage and deterioration due to dents, cracks, rust, corrosion, and wear.

b. Particular attention should be paid to highly stressed areas such as spring shackles, engine mount pads, transmission mount pads, etc. Check carefully for cracks or elongation at fastener holes, broken welds, or bent and deformed mountings.

c. Check operation of hood hinges and latch mechanism. Make certain these parts are properly aligned and lubricated.

#### 4-22. Repair

Repairs to dented body parts may be accomplished by pounding out and straightening dents, welding cracks, and refinishing exterior surface after grinding and smoothing the repaired area. Any badly deformed or damaged part, as

well as those with significant rust or corrosion damaged, should be replaced. Minor cracks on non-stressed areas of the frame may be repaired by welding.

#### 4-23. Seat Assembly Repair and Replacement

a. *Maintenance.* At each quarterly preventive maintenance inspection interval, inspect seat mounting for security, operation of adjusters and condition of cushions. Lubricate adjusters with Grease, Automotive and Artillery, MIL-G-10924. Tighten any loose hardware.

b. *Repair.* Repair consists of replacement of any defective parts, except that tears in seat or backrest cushion may be repaired by cloth tape or stitching if tears are not too extensive. See figure 4-4 for parts relationship.

c. *Replacement.* The seat adjusters are secured to the rear deck cover, and attaching hardware is accessible from underneath this cover. Refer to figure 4-4 and remove seat parts as shown in the exploded view.



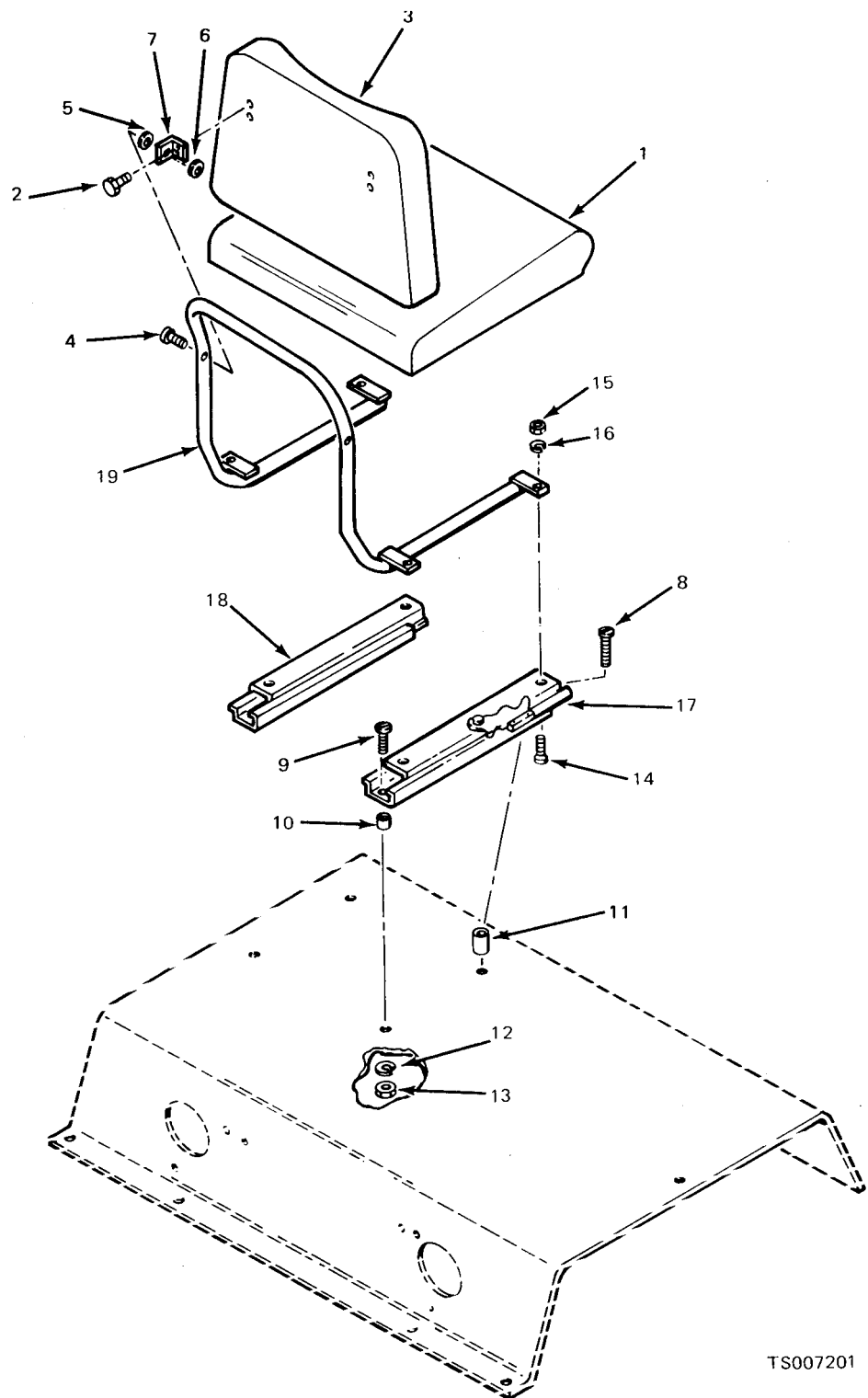

TS007201

- 1. Seat cushion
- 2. Capscrew
- 3. Backrest cushion
- 4. Capscrew
- 5. Washer

- 6. Washer
- 7. Bracket
- 8. Screw
- 9. Screw
- 10. Spacer

- 11. Spacer
- 12. Washer
- 13. Nut
- 14. Screw
- 15. Nut

- 16. Washer
- 17. Adjuster, RH
- 18. Adjuster, LH
- 19. Frame

Figure 4-4. Seat Assembly and Mounting

## Section IX. MAINTENANCE OF ELECTRICAL SYSTEM

### 4-24. General

*a. Components.* The electrical system is a 12 volts, negative ground system. System voltage is supplied by a wet-cell storage battery and an alternator which is driven off the engine crankshaft pulley by V-belts. Output of the alternator is controlled by a transistorized voltage regulator, mounted to the firewall at the left of

the steering column. The major components of the system are the battery, alternator, voltage regulator, starting motor and solenoid switch, ignition distributor, coil, and spark plugs, vehicle lights, instruments and senders. Figure 4-5 provides a wiring diagram of the electrical system.

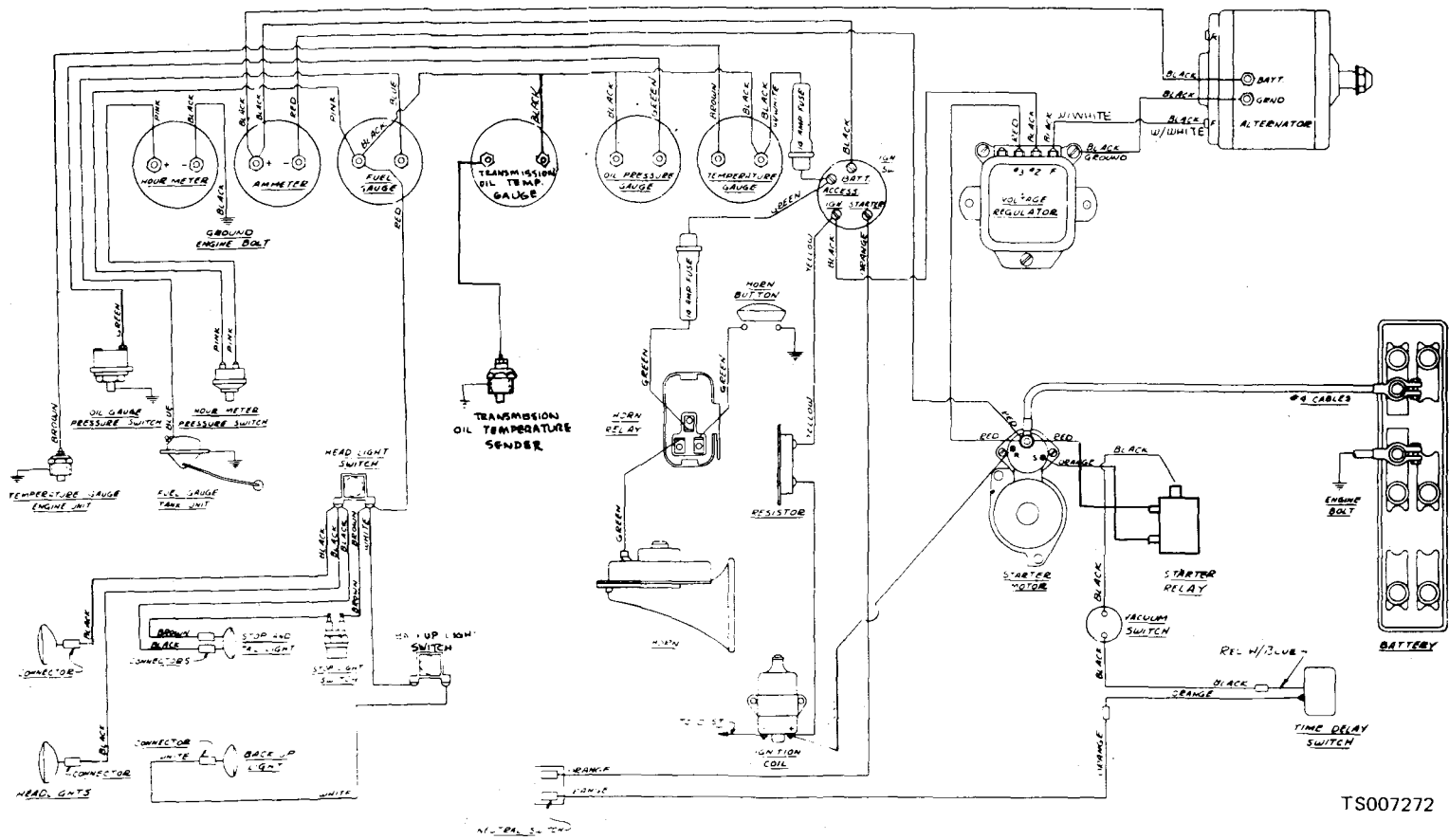

TS007272

Figure 4-5. Electrical System

*b. Ignition System.* The ignition system consists of two separate circuits, a primary (low voltage) and a secondary (high voltage) circuit (see figure 4-6). The primary circuit consists of the battery, ignition switch, primary circuit resistance wire, primary coil windings, breaker points and condenser. The secondary circuit consists of the secondary coil windings, distributor rotor, distributor cap, high tension wires and spark plugs.

*c. Ignition System Operation.* When the breaker points are closed, the primary or low voltage current flows from the battery through the ignition switch to the primary windings in the coil, then to ground through the closed breaker

points. When the breaker points open, the magnetic field built up in the primary windings of the coil moves through the coil secondary windings, producing high voltage current. This current is produced each time the breaker points open. This high voltage flows through the coil high tension lead to the distributor cap, where the rotor distributes it to one of the spark plug terminals in the distributor cap. From the plug terminal the current flows through the secondary wire to the spark plug, where the spark ignites the air-fuel mixture in the combustion chamber. This entire process is repeated during every power stroke of the engine.

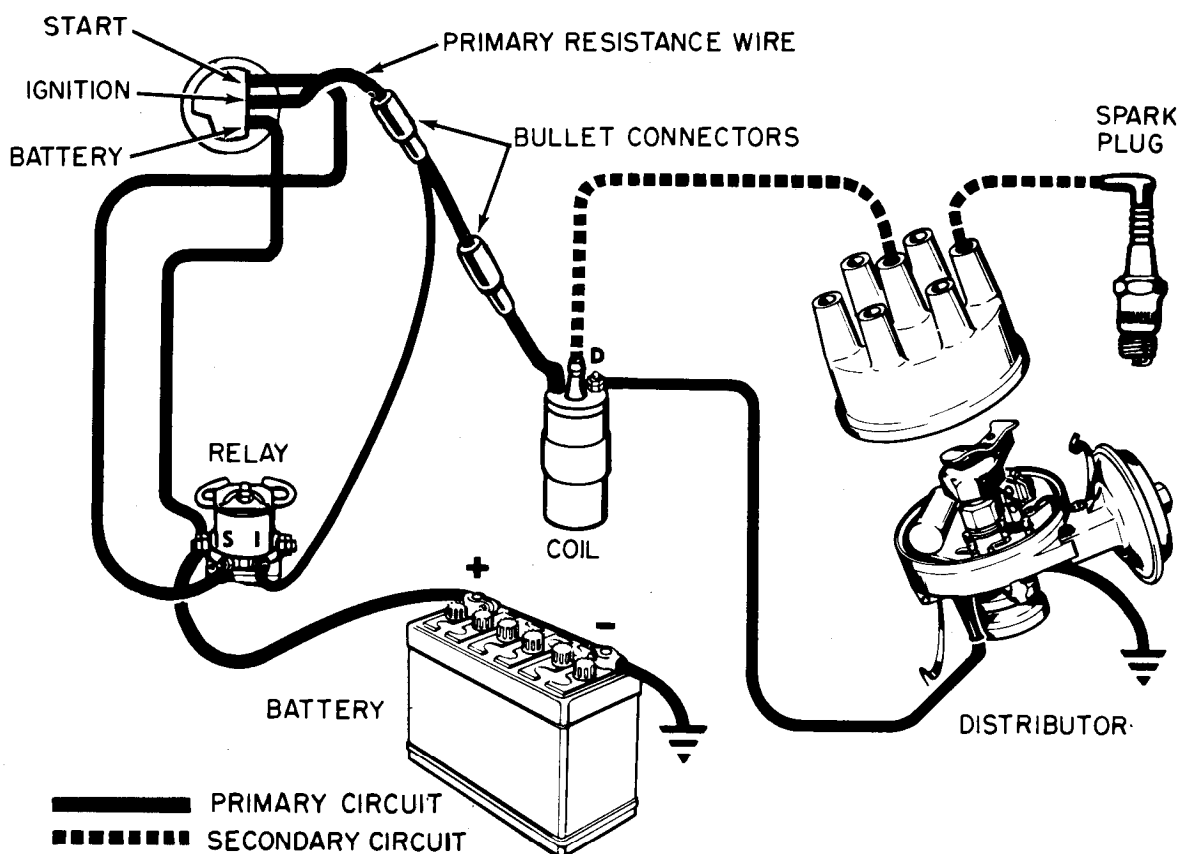

TS007273

Figure 4-6. Ignition System Circuit

*d. Starting System.* The starting system includes the starting motor and drive, starter solenoid, battery, starter relay, ignition switch, neutral start switch, and time delay and vacuum switches. The neutral start switch is normally open to prevent energizing the starter relay with

the transmission selector lever in any gear range except Neutral (N). In addition, the vacuum switch prevents starter engagement whenever the engine is running. A diagram of the system is shown in Figure 4-7.



e. *Charging System.* The charging system consists of the alternator, regulator, battery, and ammeter. The arrangement of these components is shown in figure 4-5. The alternator is belt driven by the engine. Field current levels in the alternator are controlled by the voltage regulator, and are varied as required to suit battery loads and state of charge.

**4-25. Alternator**

a. The alternator is an alternating current generator, driven by means of V-belts from the engine crankshaft damper. The alternating current is rectified internally by means of diodes, so that alternator output is in DC current. These diodes are contained in the end frame of the alternator.

b. The rotor is supported at each end by ball or roller bearings, and the rotor is dynamically balanced. Both end frames are equipped with factory-packed grease reservoirs, which eliminates the need for periodic lubrication.

c. Installation ease is aided by a single mounting lug and a slip-type field connector. The connector is polarized so that it can be connected only one way thus eliminating the hazard of

improper connections. Battery and ground connections are made at the studs on the end frame.

**4-26. Alternator Output Test**

To test the output of the alternator on the vehicle, proceed as follows:

a. Place the transmission in neutral and apply the parking brake. Make the connections as shown in figure 4-8.

b. Start the engine.

c. Increase the engine speed to approximately 2000 RPM. Turn off all lights and electrical accessories.

d. Turn the load rheostat clockwise until 15 volts is indicated on the voltmeter.

e. Observe alternator output as registered on the ammeter. Output should be approximately 20 amps at an ambient temperature of 800 F.

f. An output of 2 to 8 amperes below specifications usually indicates an open diode rectifier. An output of approximately 10 to 15 amperes below specifications usually indicates a shorted diode rectifier. An alternator with a shorted diode will usually whine, which will be most noticeable at idle speed.

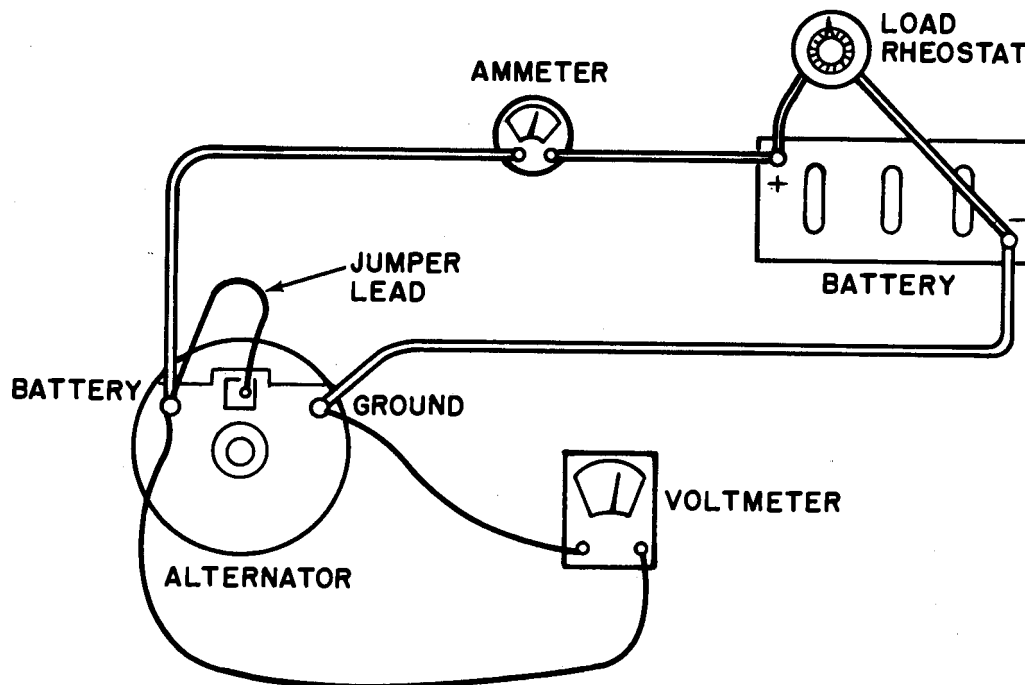

TS007275

Figure 4-8. Alternator Output Test Circuit

**4-27. Alternator Removal and Replacement .**

a. *Removal.*

- (1) Disconnect the battery ground cable.
- (2) Loosen the alternator adjusting arm bolt,

and slip the drive belt off the alternator pulley. See figure 4-35.

(3) Tag and disconnect the alternator wiring from the terminals in the rear of the alternator.

(4) Remove the alternator adjusting arm bolt. Remove the alternator mounting bolt, nut and washer from the front housing and pivot bracket.

(5) Remove the alternator from the vehicle.

*b. Installation.*

(1) Place the alternator in position in the lower bracket, aligning the through hole in the front housing with the hole in the pivot bracket.

(2) Install the long mounting bolt, nuts, and washers, and tighten securely.

(3) Install the adjusting arm bolt, but do not tighten.

(4) Connect the alternator wiring to the terminal studs in the rear housing, observing carefully the tagged notations.

(5) Install drive belt over pulley and adjust belt tension as outlined in paragraph 4-66.

(6) Tighten adjusting arm bolt securely.

(7) Connect battery ground cable.

#### **4-28. Voltage Regulator**

*a. Test.* To test the voltage regulator, make certain that the alternator output is satisfactory by first performing the alternator output test as outlined in paragraph 4-26. If alternator performance is known to be satisfactory, the only other cause for charging system malfunction is a maladjusted or defective regulator. If adjustment does not bring voltage regulator performance within specifications, the regulator must be replaced.

*b. Adjustment.* The alternator regulator adjustment is set at the factory for average operating conditions. The regulator may have to be readjusted to keep the batteries fully charged under the particular operating conditions. Proceed as follows:

(1) Locate the voltage regulator, which is mounted just to the left of the steering column in the engine compartment.

(2) Remove the socket head screw from the top of the regulator cover.

(3) Insert a screwdriver blade through the hole and engage the switch which is inside.

(4) To set the regulator for a higher charging rate, turn the screw to the next setting on the "+" side.

(5) To set the regulator for a lower charging rate, turn the screw to the next setting on the "-" side.

(6) Replace the socket head screw in regulator cover when adjustment is complete.

*c. Replacement.*

(1) Disconnect the battery ground cable.

(2) Tag and disconnect the wiring to the regulator terminals.

(3) Remove the regulator mounting screws, and the regulator from the bracket.

(4) Position the new regulator against the bracket, and install mounting screws.

(5) Hook up wiring to the regulator.

(6) Connect battery ground cable. Adjust regulator as outlined in subparagraph *b* above.

#### **4-29. Starter**

*a. General.* The starter is a 12-volt unit that has the solenoid mounted on the starter housing (fig. 4-9). The solenoid is energized when the starter relay contacts are closed. This action engages the starter drive with the flywheel ring gear, starting the engine. An overrunning clutch in the drive protects the starter from excessive speed when the engine starts. The starter current flows through the solenoid energizing coil until the solenoid plunger is at the end of its travel. The plunger then closes a set of contacts that by-pass the energizing coil, letting the holding coil keep the starter drive engaged.

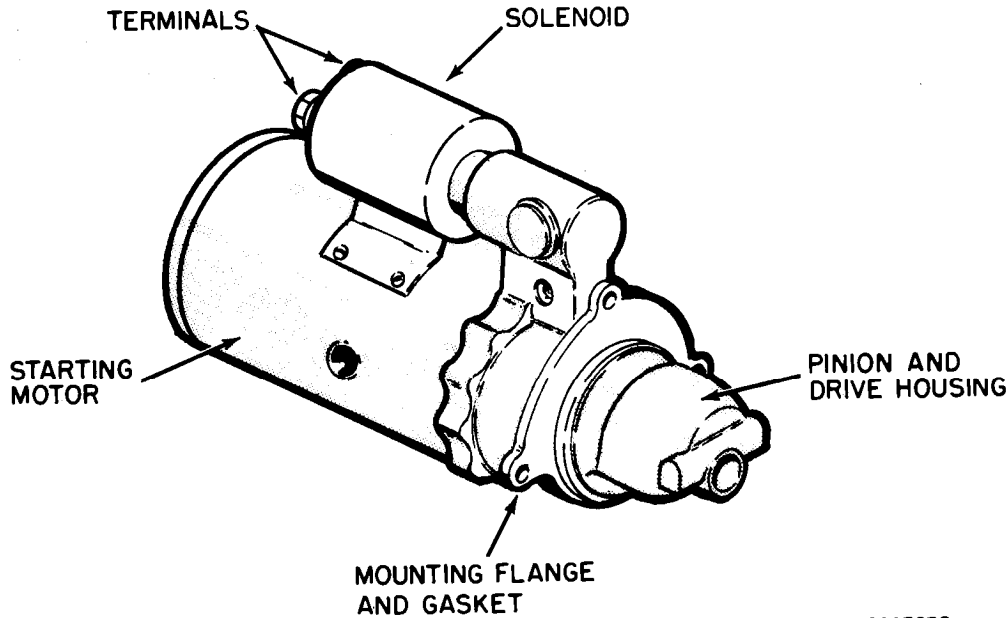

TS007276

Figure 4-9. Starter Details

*b. Testing.*

(1) Use a battery known to be in good condition and an accurate voltmeter. Connect the positive lead of the voltmeter to the positive terminal of the battery, and the negative lead to the negative (grounded) terminal of the battery. Record the voltage reading.

(2) Pull the high tension lead from the ignition coil to prevent the engine from starting during the starting motor test.

(3) Connect the positive lead of the voltmeter to ground and the negative lead of the voltmeter to starter switch terminal. Turn and hold the ignition switch to the start position and read the voltmeter.

(4) Compare the voltmeter reading with the previously recorded voltmeter reading. If the voltage drop is more than 4 volts, or if the second reading is less than 8 volts, the starting motor is probably faulty.

*c. Removal.*

(1) Disconnect the positive battery cable from the battery.

(2) Disconnect and tag the electrical leads from the starting motor.

(3) Remove the starting motor from the flywheel housing, after removal of three mounting bolts. Pull straight out on the starting motor to disengage the pinion gear from the ring gear.

*d. Installation.*

(1) Position the starting motor against the flywheel housing so that mounting holes line up and install three mounting bolts. Torque bolts to 12-15 ft/lbs. Use of a new gasket when installing motor is advised.

(2) Connect the battery cable to the battery and to the starting motor. Connect wiring as shown in figure 4-7.

(3) Check the operation of the starting motor. Make sure it cranks the engine as required.

**4-30. Ignition Tune-up**

Ignition tune-up is the orderly and systematic process of checking the engine and accessory equipment to maintain or restore satisfactory engine performance. Ignition tune-up must be accomplished semi-annually (500 hours) and more frequently if engine performance indicates the need for these services. Perform ignition tune-up as outlined in the following paragraphs after checking the following items:

*a. Air Cleaner.* Be sure air cleaner has received recent service and is not restricted.

*b. Carburetor.* Check approximate idle speed and mixture adjustment. (These will have to be readjusted after the tune-up.)



c. *Fuel Filter.* Change fuel filter element if it has been in service over 100 hours.

**4-31. Spark Plug Check.**

Under normal conditions, these spark plugs will give long life performance with the normal maintenance listed in this manual. The spark plugs should be cleaned, tested and gapped at the recommended intervals.

a. Loosen the spark plugs one full turn, then blow any accumulation of dirt out of the spark plug wells before completing the removal.

b. Examine firing end of plug carefully and compare findings with table 4-3. Careful analysis of spark plug deposits can reveal a great deal about engine operating conditions.

c. Remove carbon and other deposits from the threads with a stiff wire brush. Any deposits will retard the heat-flow from the plug to the cylinder head, causing spark plug overheating and pre-ignition.

Table 4-3. Spark Plug Condition Analysis

	Plug Condition	Cause	Service procedure	
			Clean & regap	Replace
Light tan or gray deposits on firing tip Black, dry fluffy carbon deposits on insulator tips, exposed shell surfaces and electrodes	Normal Carbon fouled	Normal use and engine condition Too cold a plug, weak ignition, dirty air cleaner, defective fuel pump, too rich a fuel mixture, improperly operating heat riser or excessive idling	X X	
Wet, black deposits on the insulator. shell bore and electrodes	Oil fouled	Excessive oil entering combustion chamber through worn rings and pistons, excessive clearance between valve guides and stems, or worn or loose bearings	X	
Dark gray, black, yellow or tan deposits or a fused glazed coating on the insulator tip Deposits built up, closing gap between electrodes	Lead fouled Gap bridged	Highly leaded gasoline Excessive oil or carbon fouling	X X	
Severely worn or eroded electrodes	Worn	Caused by severe service and not servicing plugs at proper intervals		X
Melted or spotty deposits resembling bubbles or blisters on electrode and insulator	Fused spot deposit	Sudden acceleration	X	
White or light gray insulator with small black or gray brown spots and with bluish-burnt appearance of electrodes	Overheating	Engine overheating. Wrong type of fuel, loose spark plugs, too hot a plug, low fuel pump pressure or incorrect ignition timing.	X	
Melted electrodes and possibly blistered insulator, metallic deposits on insulator indicate <i>engine</i> damage	Preignition	Engine overheating. Wrong type of fuel, incorrect ignition timing or advance. Too hot a plug, burnt valves or engine overheating.		X

d. Clean any heavy carbon deposits from the inside of the plugs with a thin-bladed knife, then finish cleaning them with an abrasive-type cleaner. Use the cleaner sparingly, as excessive abrasive blasting may damage the porcelain around the center electrode. If the porcelain is badly glazed or eroded, replace the spark plugs.

e. After cleaning, examine the plug carefully for cracked or broken insulator, badly eroded electrodes and other signs of failure. Replace as required.

f. Clean the electrode surfaces with a small file. Dress the electrodes to secure flat parallel surfaces on both the center and side electrode.

g. Adjust the spark plug gap to 0.035 inch, by bending only the outside electrode. Use a round

wire-type gage to check the gap. If old spark plugs are reused, install with new gaskets. Torque to 30 ft/lbs.

NOTE

Do not overtighten spark plugs, the gap may change considerably due to distortion of the plug outer shell, or the insulator may be cracked.

**4-32. Spark Plug Wiring Replacement**

Whenever an examination of the high tension wiring reveals cracks, chafed areas, burned insulation or other deterioration, the wiring set should be replaced. Such poor insulation leads to rapid spark plug fouling and misfiring due to current leakage.

a. *General.* When removing the wires from the

spark plugs, grasp, twist, and pull on the moulded cap only. Do not pull on the wire because the wire connections inside the cap may become separated or the weather seal may be damaged.

*b. Removal.* Disconnect wires at plugs and at the distributor cap. Remove coil high tension lead.

*c. Installation.* Connect wires to proper plugs (see figure 4-10). Insert ends of wires in the correct sockets in distributor cap. Be sure wires are all the way down into their sockets and that they are held firmly in position. The No. 1 plug is the front plug. Install wires into distributor sockets in a clockwise direction, starting at No. 1 socket. NOW install coil high tension lead. Push all weather seals into position.

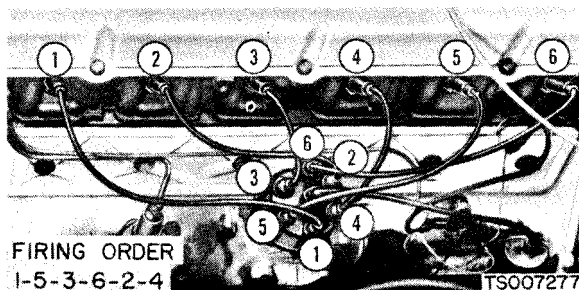

Figure 4-10. Spark Plug Wiring

#### 4-33. Ignition Coil Check

Check the coil for secure mounting. Wipe the coil with a damp cloth moistened in Stoddard type solvent and check for cracks in the coil case. Check coil terminals for tight connections and proper polarity.

#### 4-34. Distributor Checks

Disconnect spark plug wiring at the distributor cap. Remove distributor cap and make the following inspection:

*a. Distributor Cap.* Clean the distributor cap with a soft bristle brush and Solvent, Federal Specification P-D-680. Dry the cap with compressed air. Inspect the cap for cracks, burned contacts, permanent carbon tracks or dirt or corrosion in the sockets. Replace the cap if it is defective.

*b. Rotor.* Clean the rotor with a soft bristle brush and a Stoddard type cleaning solvent. The rotor should be dried with compressed air. Inspect the rotor for cracks or burning. Replace the rotor if it is defective.

*c. Breaker Points.* Check points for pitting, burning or excessive metal transfer as outlined in the following steps:

(1) The normal color of contact points should be a light gray. If the contact point surfaces are black, it is usually caused by oil vapor, or grease from the cam. If they are blue, the cause is usually excessive heating due to improper alignment, high resistance or open condenser circuit.

(2) Badly pitted points may be caused by a defective or improper condenser capacity. If the condenser capacity is too high, the crater (depression) will form in the positive contact. If the condenser capacity is too low, the crater will form in the negative contact.

(3) For a temporary repair, dress the contact points with a few even strokes using a clean fine-cut contact file. Do not attempt to remove all roughness or dress the point surfaces down smooth.

#### CAUTION

**Never use emery cloth or sandpaper to clean points as particles will be imbedded in the points and cause arcing and rapid burning.**

#### 4-35. Distributor (Breaker) Points Dwell Adjustment

Use a dwell meter to check the contact dwell. It is not advisable to use a feeler gage to adjust or to check the gap of used breaker points because the roughness of the points makes an accurate gap reading or setting impossible. Clean the breaker points and check and adjust the alignment. Check the contact dwell following the instructions of the dwell meter manufacturer. See table 4-4 for proper setting.

#### 4-36. Breaker Point Alignment

The vented-type breaker points must be accurately aligned in order to realize the full advantages provided by this design, and to assure normal breaker point life. Any misalignment of the breaker point surfaces will cause premature wear, overheating, and pitting.

*a.* Turn the distributor cam so that the breaker points are closed and check the alignment of the points (fig. 4-11).

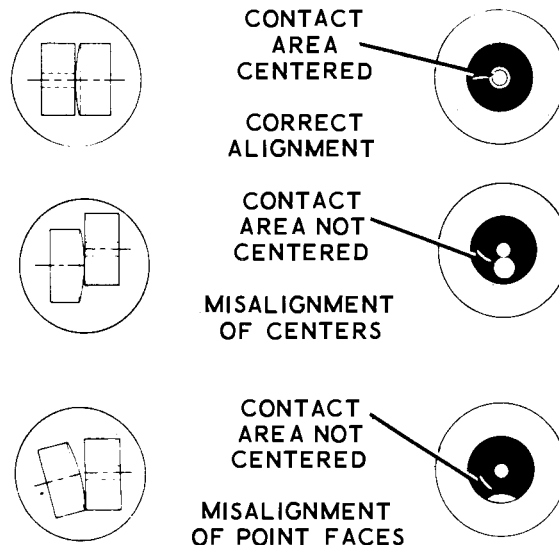

TS007278

Figure 4-11. Point Alignment Chart

Table 4-4. Engine Tune-up Specifications

Compression pressure, PSI	140-170
Firing order	1-5-3-6-2-4
Engine idle speed, RPM . . . . .	500 to 550 (transmission in drive range)
Engine idle manifold vacuum (in./Hg) . . . . .	17
Initial timing advance 6° BTDC (vacuum line disconnected)	
Maximum governed speed:	
No load	2750 RPM
Loaded . . . . .	2600 RPM
Vacuum advance (1000 RPM)	0°-4° at 8 in.
(degrees at in./Hg vacuum	4°-7° at 10 in.
5.5°-8.5° at 17 in.	
Spark plug gap (inches)	0.032-0.036
Breaker arm spring tension	17-21 oz
Breaker point gap (inches)	0.024-0.026
Dwell angle at idle	35° to 38°

b. Align the breaker points to make full face contact by bending the stationary breaker point bracket. Do not bend the breaker arm. See figure 4-12.

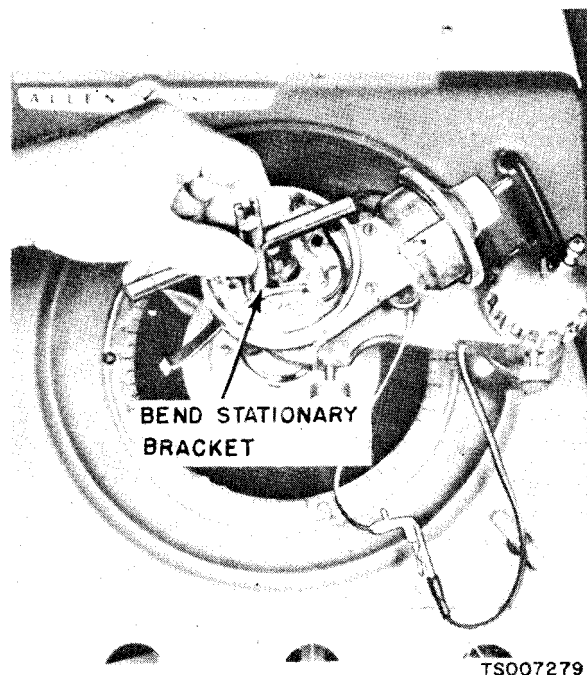

TS007279

Figure 4-12. Aligning Breaker Points

c. After aligning breaker points, adjust breaker point gap to 0.024-0.026 inch. Use a wire feeler gage as shown in figure 4-13 to check the point opening. If the point gap is not 0.025 inch, loosen the lock screw with a screwdriver and position the adjusting plate of the point set until the correct point opening is attained. Tighten the lock screw.

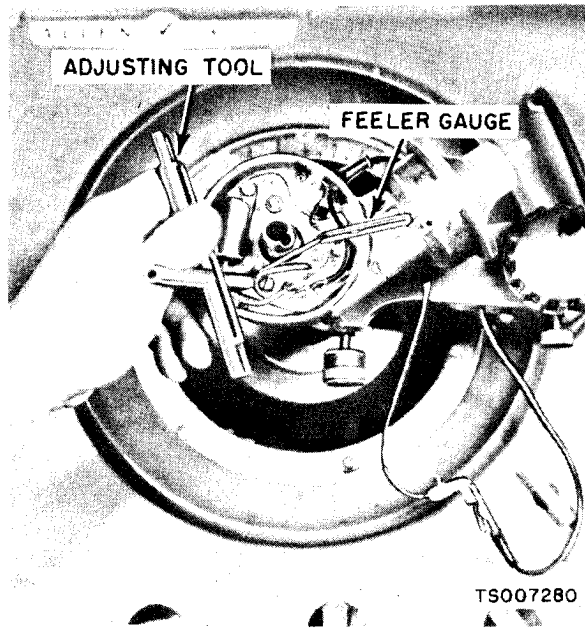

Figure 4-13. Adjusting Point Gap

#### 4-37. Breaker Point Spring Tension Adjustment

To check the spring tension, place the hooked end of a spring tension gage over the movable breaker point, then pull the gage at a right angle (90°, to the movable arm until the breaker points just start to open (fig. 4-14). If the spring tension is not between 17-21 ounces, it must be adjusted. To adjust the spring tension, proceed as follows:

a. Disconnect the primary and condenser leads at the breaker point assembly primary terminal.

b. Loosen the nut holding the spring in position. Move the spring toward the breaker arm pivot to decrease tension and in the opposite direction to increase tension.

c. Tighten the locknut, then check spring tension. Repeat the adjustment until the specified spring tension is obtained.

d. Install the primary and condenser leads with the lockwashers and tighten the nut securely.

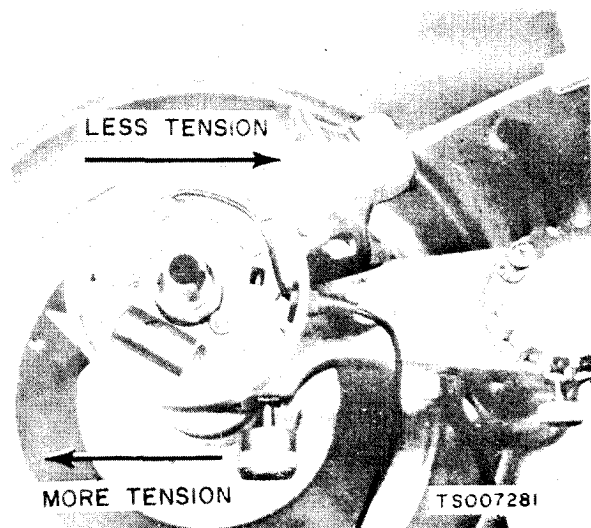

Figure 4-14. Checking and adjusting Breaker Point Spring Tension

#### 4-38. Ignition Timing Adjustment

The ignition timing mark is a stamped line on the torque converter to flywheel flexplate. This line is viewed through a hole in the engine rear coverplate, on the lower left side of the engine. A rubber snap-in cover is used in this opening to prevent entry of dust, dirt, and moisture. When the cover is removed, the timing mark is viewed through the hole as shown in figure 4-15. Degree marks from TDC (0°) to 14 (14° before top dead center, No. 1 piston) are marked on the engine rear coverplate. By connecting a timing light to the No. 1 (front) spark plug, and aiming the light at the timing marks, the ignition timing can be determined and adjusted as required. Proceed as outlined below:

a. Clean and mark the timing marks with chalk or white paint.

b. Disconnect the vacuum line and plug the vacuum line to prevent leaks.

c. Connect a timing light to a terminal of the No. 1 cylinder spark plug wire. Connect tachometer to the engine.

d. Start the engine and reduce the engine idle speed to 600 RPM to be sure that the centrifugal advance is not operating. Adjust the initial ignition timing to specifications (see table 4-4) by

loosening the clamp bolt at the base of the distributor and rotating the entire distributor counterclockwise to advance the timing, clockwise to retard. Tighten the clamp bolt when proper timing (see table 4-4) is obtained.

e. Accelerate engine to 2000 RPM, in steps, to verify that timing advances. If advance mechanisms are not operating, report to direct or general support maintenance, or replace the entire distributor.

f. Disconnect timing light and tachometer, and install plug in timing hole.

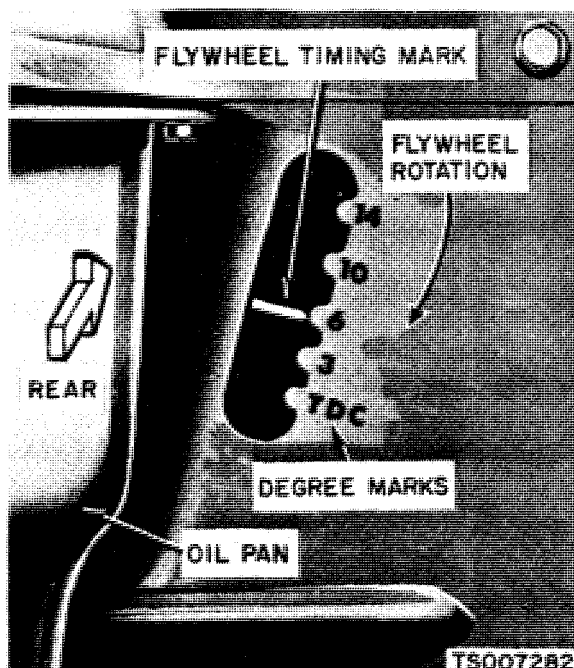

Figure 4-15. Timing Marks

#### 4-39. Ignition Distributor

a. *Test.* Test of the distributor requires a timing light to be connected and used in the same manner as for setting ignition timing, outlined in the preceding paragraph. Refer to paragraph 4-38 and perform steps a, b, c, and d, then proceed as follows:

(1) Check the centrifugal advance for proper

operation. Start the engine and accelerate it to approximately 2000 RPM. If the ignition timing advances, the centrifugal advance mechanism is functioning properly. Note the engine speed when the advance begins and the amount of advance. Stop the engine.

(2) Unplug the vacuum line and connect it to the distributor vacuum advance unit. Start the engine and accelerate it to approximately 2000 RPM. Note the engine speed when the advance begins and the amount of advance. Advance of the ignition timing should begin sooner and advance farther than when checking the centrifugal advance alone. Stop the engine.

(3) If advance mechanisms do not operate properly, replace the distributor and refer the defective unit to direct or general support maintenance.

b. *Removal.* The distributor is driven by a helical gear on the camshaft which maintains engine ignition and valve timing. To avoid the necessity of retiming the engine, take care to mark the proper position of distributor and rotor prior to removal; and avoid disturbing crankshaft position during the time the distributor is removed.

(1) Refer to figure 4-16 and disconnect vacuum tube (1) from distributor.

(2) Pull spark plug wires (2) and coil wire (4) from distributor cap.

(3) Scribe or scratch a mark on the distributor body and the cylinder block boss to indicate the proper position of the body, and remove the distributor cap and scribe another line indicating the position of the rotor. These lines will be used when installing the distributor, to re-establish proper ignition timing.

(4) Remove screw (15), lockwasher (16) and clamp (14). Lift distributor assembly (17) out of cylinder block.

#### NOTE

Do not rotate the engine crankshaft while the distributor is removed. Otherwise, the engine will have to be retimed.

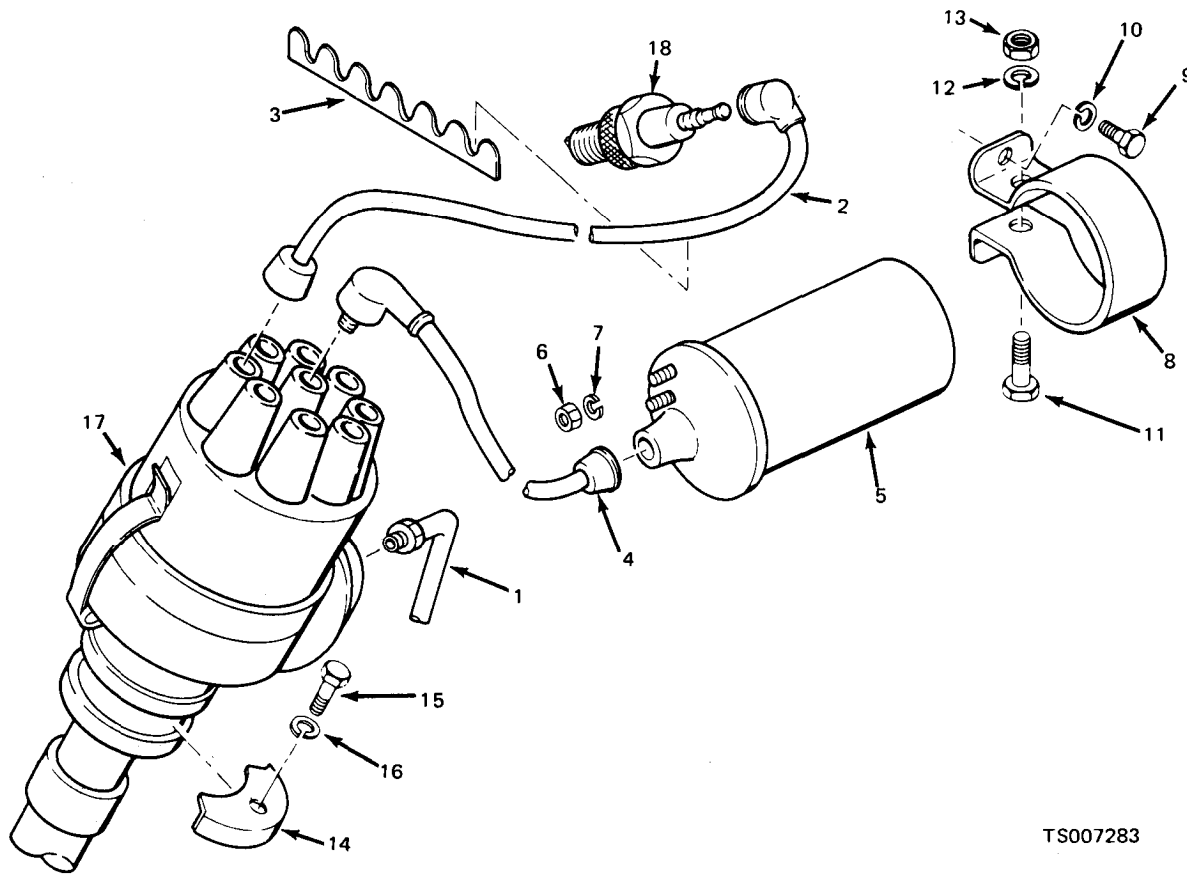

TS007283

- |                  |                   |                 |
|------------------|-------------------|-----------------|
| 1. Tube assembly | 7. Lockwasher     | 13. Nut         |
| 2. Lead set      | 8. Mounting strap | 14. Clamp       |
| 3. Separator     | 9. Screw          | 15. Screw       |
| 4. Lead          | 10. Lockwasher    | 16. Lockwasher  |
| 5. Ignition coil | 11. Screw         | 17. Distributor |
| 6. Nut           | 12. Lockwasher    | 18. Sparkplug   |

Figure 4-16. Distributor and Coil Installation

*c. Installation.*

(1) If the crankshaft has not been rotated while the distributor was removed, position the distributor in the block with the rotor aligned with the mark previously scribed on the distributor body, and with the marks on the distributor body and engine block in alignment. With the distributor correctly seated, install the distributor retaining screw.

(2) If the crankshaft has been rotated while the distributor was removed, rotate the crankshaft until the No. 1 piston is on TDC after the compression stroke. Position the distributor in the block with rotor at the No. 1 firing position. Install, but do not tighten, the distributor retaining bolt. Rotate the distributor

body clockwise until the breaker points are just starting to open. Tighten the retaining bolts.

(3) Connect the distributor primary wire, hook up the vacuum hose, install distributor cap, and hook up spark plug wires. Refer to figure 4-10 for spark plug wiring.

(4) Set ignition timing as outlined in paragraph 4-38.

4-40. Ignition Coil

*a. Testing.* To test the ignition coil, pull the high tension lead from the center contact of the distributor. Hold the lead by the insulation so that the end contact is within 1/4 inch of an unpainted, grounded portion of the engine. Turn the starter and ignition switch to START. A hot

spark should jump from the high tension terminal to ground as the engine is cranked. If no spark is visible, and if all wiring is intact, the coil may be faulty.

*b. Removal.*

(1) Tag and disconnect the primary wiring from the coil terminals.

(2) Refer to figure 4-16 and disconnect distributor high tension lead (4) from coil (5).

(3) Loosen screw (11) and slide coil (5) out of mounting strap (8).

*c. Installation.*

(1) Slide the coil (5) into the strap (8) and tighten screw (11) to hold coil in position.

(2) Connect high tension lead (4) to coil terminal.

(3) Connect primary wiring to coil terminals as shown in diagram, figure 4-6.

#### 4-41. Battery and Cables

*a. Battery Cleaning.*

(1) Raise the engine hood to gain access to the battery and battery cable connections.

(2) Remove dirt and grease accumulated on the battery with a clean cloth.

(3) Pour a solution of baking soda and water on the top of the battery to neutralize any acid present. Continue to pour until the solution no longer bubbles when it contacts the battery.

(4) Remove any corrosion from battery terminals by scrubbing with a solution of baking soda, or ammonia, and water.

**CAUTION**

**Remove ground (negative ) cable first.**

**When installing cables, install ground cable last.**

(5) Loosen the nuts that secure the battery cables to the battery posts; remove the cables. Clean all corrosion from the cable clamps and posts with a wire brush or jackknife. Replace the cables; tighten the nuts.

(6) Lightly coat the battery posts and cable clamps with high temperature grease.

*b. Battery Testing.*

(1) Test the state of the electrolyte using a hydrometer. The specific gravity of the electrolyte at 750 F shall be 1.225 minimum for

normal temperature operation, or 1.265 minimum for cold temperature operation. For constant operation in above-freezing temperatures, electrolyte strength may be reduced to 1.225 by diluting with distilled water. If the battery is not fully charged, charge it.

(2) Connect a voltmeter across the terminals of the battery, and note the reading. Pull the high tension cable from the ignition coil, crank the engine with the starter, and note the reading on the voltmeter. If the difference between the two readings is more than 4 volts or the second reading is less than 8 volts, replace the battery.

*c. Battery and Cable Removal and Replacement.*

**NOTE**

Always disconnect the battery ground cable first when replacing battery or cables. On reinstallation, connect battery ground cable last.

(1) Loosen the nuts on the battery cable terminals and disconnect the cables from the battery posts. Clean cable terminals as outlined in subparagraph a above.

(2) Refer to figure 4-17 and remove the nuts (6) on the battery hold-down studs (10) at each end of the battery. Lift off the hold-down frame (9) and remove the battery (14) from the vehicle.

(3) Remove the starting motor mounting bolt and lockwasher that secure the ground cable to the cylinder block; remove the cable.

(4) Remove the nut and lockwasher that secure the positive battery cable to the solenoid switch mounted on the starting motor; remove the cable.

(5) Install new cables. Make certain the connections at the cylinder block and starter solenoid are clean and tight.

(6) Install new battery (14) and secure with hold-down frame (9) and nuts (6) on hold-down studs (10). Make certain the battery posts are in the proper position; negative post towards the front.

(7) Connect cable terminals to battery posts and tighten terminal screws. Coat terminals with a light film of high temperature grease to retard corrosion.

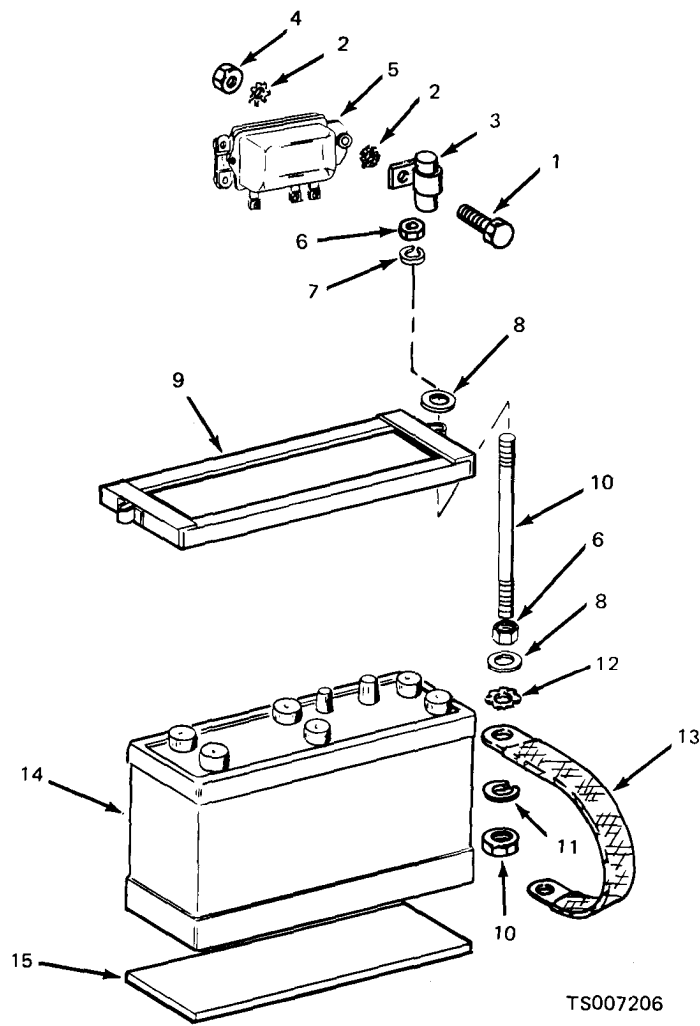

TS007206

- |                      |                    |                  |
|----------------------|--------------------|------------------|
| 1. Screw             | 6. Nut             | 11. Lockwasher   |
| 2. Washer            | 7. Washer          | 12. Washer       |
| 3. Capacitor         | 8. Washer          | 13. Ground strap |
| 4. Nut               | 9. Hold-down frame | 14. Battery      |
| 5. Voltage regulator | 10. Stud           | 15. Cushion      |

Figure 4-17. Battery and Regulator Mounting

**4-42. Gages, Switches, and Hourmeter**

If testing of our troubleshooting the electrical system indicates the cause of an abnormal gage reading or system malfunction to be in the instrument or switch rather than elsewhere in the circuit, the defective gage or switch will have to be replaced.

*a. Testing.*

(1) Faulty light or ignition switches can be tested by bridging the switch terminals with a jumper wire. If circuit then operates normally, the switch is faulty.

(2) Meters and gages can be tested by bridging meter terminals with an ohmmeter (temperature and fuel level gages), ammeter or voltmeter. The temperature and fuel level gages operate on a variable resistance principle; the ohmmeter will measure the resistance through the sending unit. If resistance is infinite, the sender may be faulty or wiring broken.

(3) Inspect meters and gages for cracked glass, illegible dial faces, damaged terminals, faulty movements, and other damage.

(4) Inspect switches for rough, catching, or



binding operation, damaged terminals, signs of overheating, damaged threads, and other damage; replace damaged switches.

b. *Replacement.* Refer to figure 4-18 for an illustration showing all the gages and switches

and their method of mounting in the instrument panel. Tag and disconnect wiring before removal of any gage or switch. Reinstall as shown in figure 4-18. Wiring codes and connections are shown in figure 4-5.

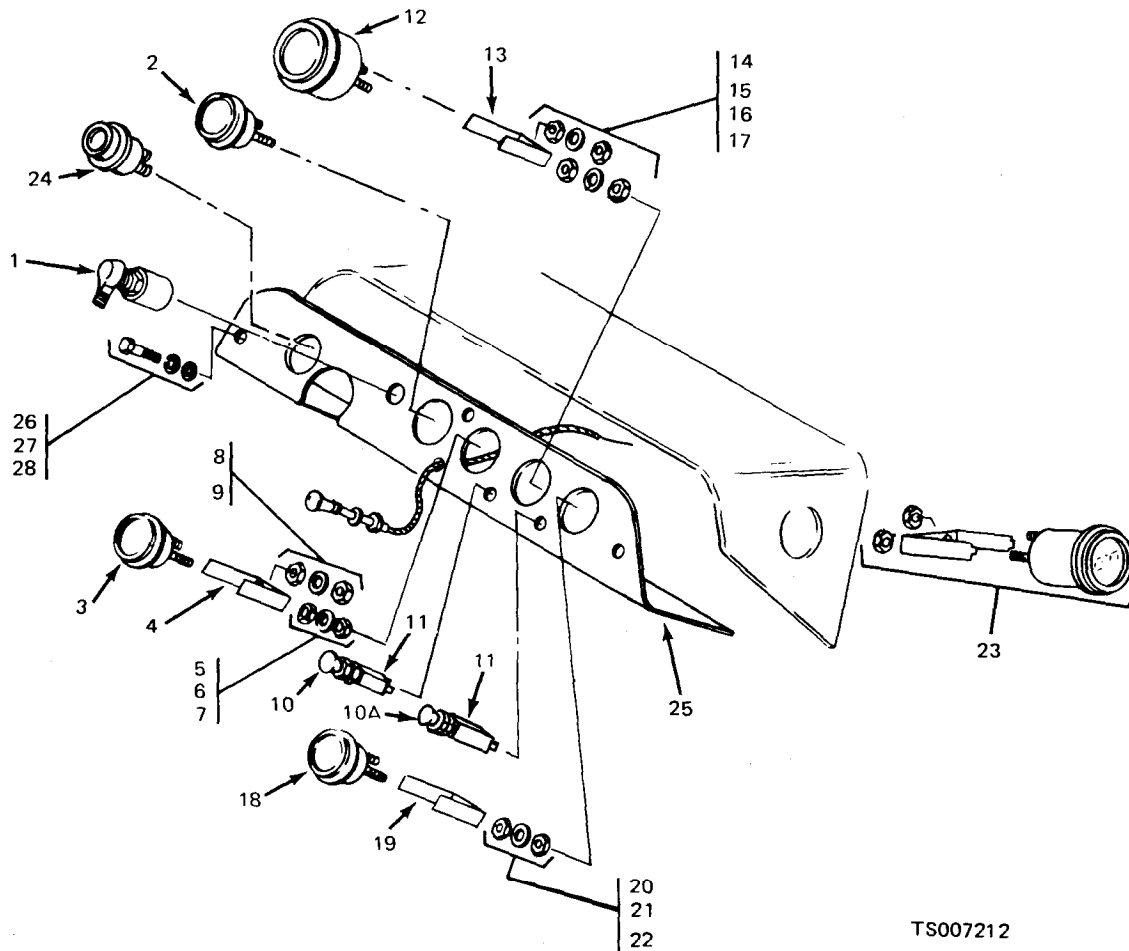

TS007212

- |                           |                     |             |                                       |
|---------------------------|---------------------|-------------|---------------------------------------|
| 1. Ignition Switch        | 9. Washer           | 15. Washer  | 22. Nut                               |
| 2. Water temperature gage | 10. Switch          | 16. Nut     | 23. Hourmeter                         |
| 3. Oil pressure gage      | 10A. Switch         | 17. Nut     | 24. Transmission oil temperature gage |
| 4. Bracket                | 11. Switch          | 18. Ammeter | 25. Instrument panel                  |
| 5. Nut                    | 12. Fuel level gage | 19. Bracket | 26. Screw                             |
| 6. Washer                 | 13. Bracket         | 20. Nut     | 27. Lockwasher                        |
| 7. Nut                    | 14. Nut             | 21. Washer  | 28. Nut                               |
| 8. Nut                    |                     |             |                                       |

Figure 4-18. Instrument Panel and Gages

#### 4-43. Lights and Horn

a. *Headlights.* The tractor is equipped with two sealed-beam headlights, controlled by a push-pull switch on the instrument panel. The headlights are mounted in a metal bracket and recessed behind the front grille plate to provide protection against breakage.

b. *Stop and Taillight.* The combination stop and taillight is recessed behind the rear bumper plate and is mounted to the rear deck cover. This lamp has a dual-filament bulb. One filament is illuminated whenever the headlight switch is on, while the second filament is wired through the

pressure switch in the brake system and is illuminated whenever the brakes are applied.

*c. Back-up Light.* The back-up, lamp is mounted in the same way as the stop and taillamp, and differs only in having a clear lens, rather than red, and a single filament bulb. The lamp is controlled by a switch on the instrument panel.

*d. Horn.* The tractor is equipped with a single electrical horn, mounted to the cowl plate inside the engine compartment. The horn is controlled by a horn button in the center of the steering column. When this button is depressed, a horn relay is energized to sound the horn. An in-line fuse for the horn circuit is included in the wire from the ignition switch terminal to the horn relay. The horn relay is mounted on the cowl plate beside the steering column.

*e. Wiring.* Refer to Section IX, Maintenance of Electrical System for the wiring diagram showing wire routing and color codes for the lights and horn.

#### **4-44. Inspection and Test**

*a. Lights.* At each quarterly maintenance in-

terval, check headlights, stop and taillight, and back-up lamp for proper operation. Check for secure mounting of light assemblies and switches, and make certain the wiring and connectors are clean, tight, and well-insulated. The plastic lenses in the rear lights may become discolored due to age or exposure to contaminants. If discoloration is apparent, the lenses and gaskets should be replaced.

*b. Horn.* At each quarterly maintenance interval, test the horn for proper operation. If horn is inoperable, replace the horn fuse or relay. If horn tone is weak, check wiring connections for secure connections and replace horn if required. Check all wiring to make sure that wiring and connections are clean, tight, and well-insulated.

#### **4-45. Replacement**

*a. Headlight.* Refer to figure 4-19 and replace sealed-beam headlight parts as required. Make certain that wiring connections are clean and tight after installing a new sealed beam lamp.

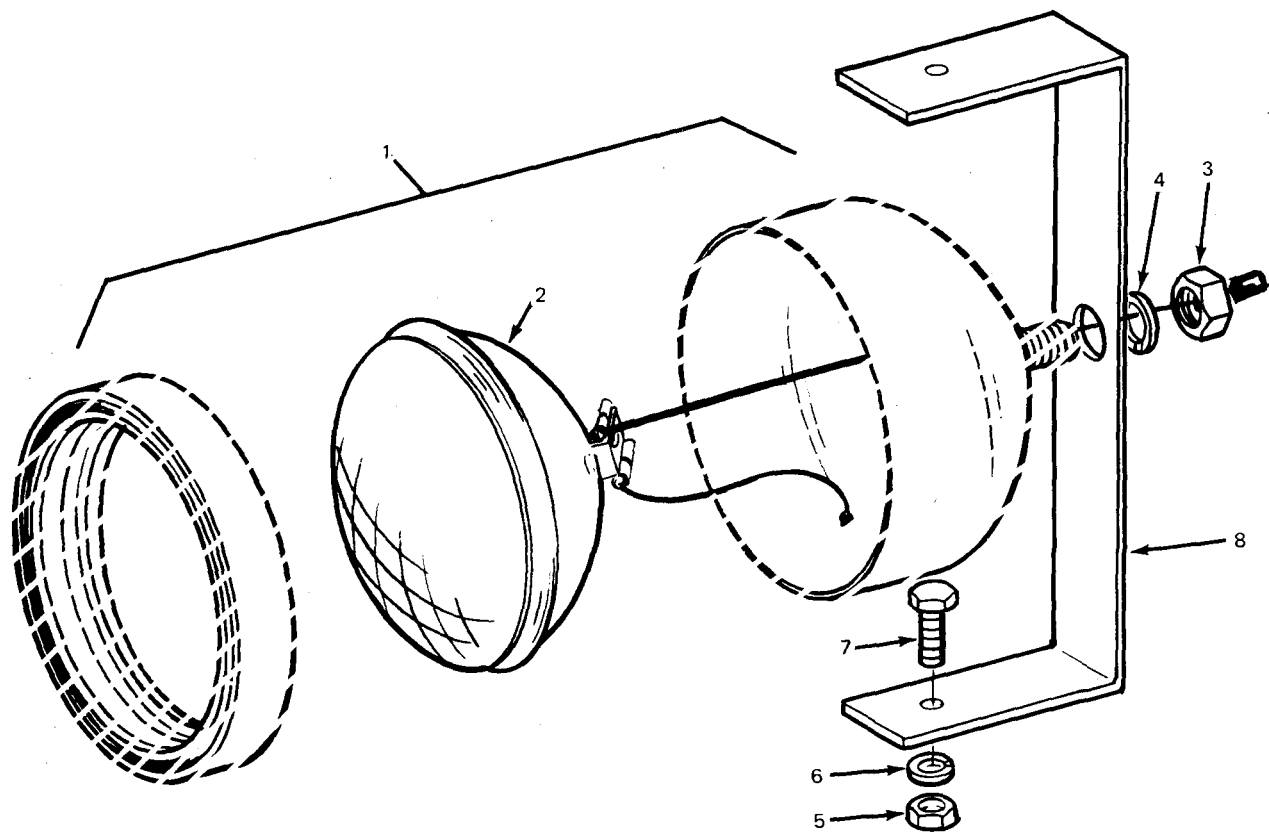

TS007214

- |                      |               |
|----------------------|---------------|
| 1. Headlamp Assembly | 5. Nut        |
| 2. Sealed beam lamp  | 6. Lockwasher |
| 3. Nut               | 7. Screw      |
| 4. Lockwasher        | 8. Bracket    |

Figure 4-19. Headlamp Installation

*b. Stop and Tail Lamp.* Refer to figure 4-20, and replace lamp parts as required. For lens or bulb replacement, the lamp assembly need not be

removed from the rear deck cover. Make certain that wiring connections are clean and tight after installing a new lamp assembly.

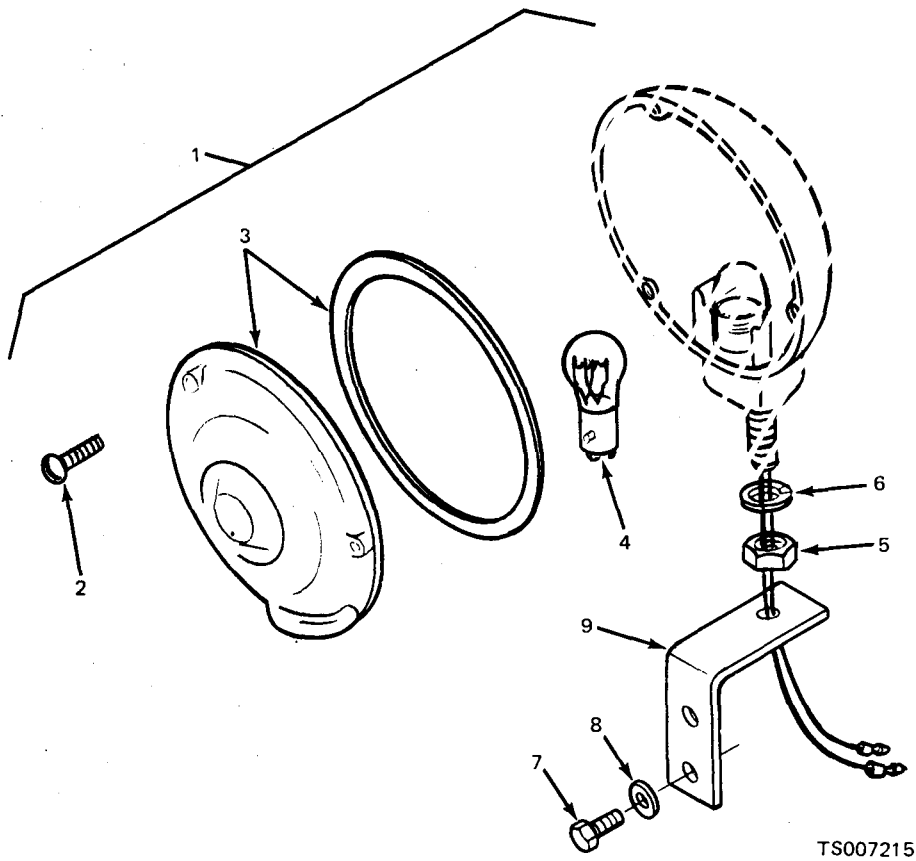

TS007215

- 1. Light assembly
- 2. Machine screw
- 3. Lens and gasket

- 4. Lamp
- 5. Nut
- 6. Lockwasher

- 7. Screw
- 8. Lockwasher
- 9. Bracket

Figure 4-20. Stop and Tail Lamp Installation

c. *Back-up Lamp.* Refer to figure 4-20 and procedures of subparagraph *b*, above, for replacement of back-up lamp parts.

d. *Horn.* Refer to figure 4-21 for replacement of

horn or horn relay. Replacement of horn button and contact parts is covered in TM 10-3930-633-34.

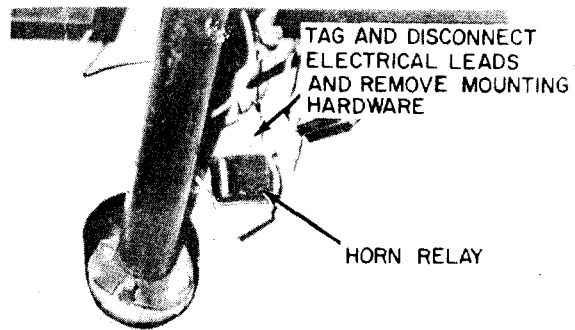
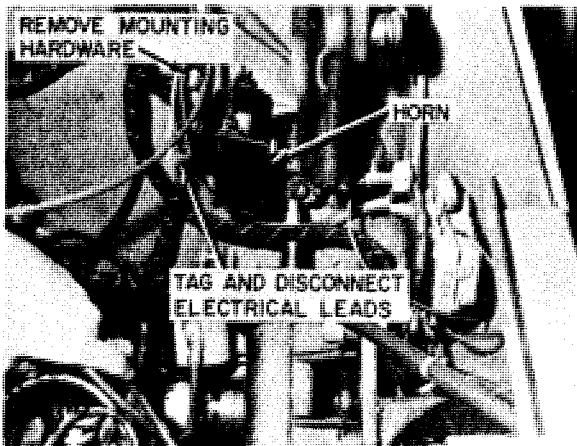

TS007284

Figure 4-21. Horn and Horn Relay

**Section X. MAINTENANCE OF FUEL SYSTEM****4-46. General**

a. The fuel system consists of the fuel tank (17 gallon capacity), mounted to the right side of the frame, a mechanical, diaphragm-type pump driven off the engine and protected by a fuel filter with a disposable element cartridge, the single-barrel down-draft carburetor, dry-type air cleaner, velocity governor, and the necessary

lines and fittings to complete the system. Refer to figure 4-22 for details of the fuel system.

b. A variable resistance type of float and sender unit is mounted in the fuel tank and connected to a fuel gage on the instrument panel. The fuel filler cap is a safety type with an integral strainer.

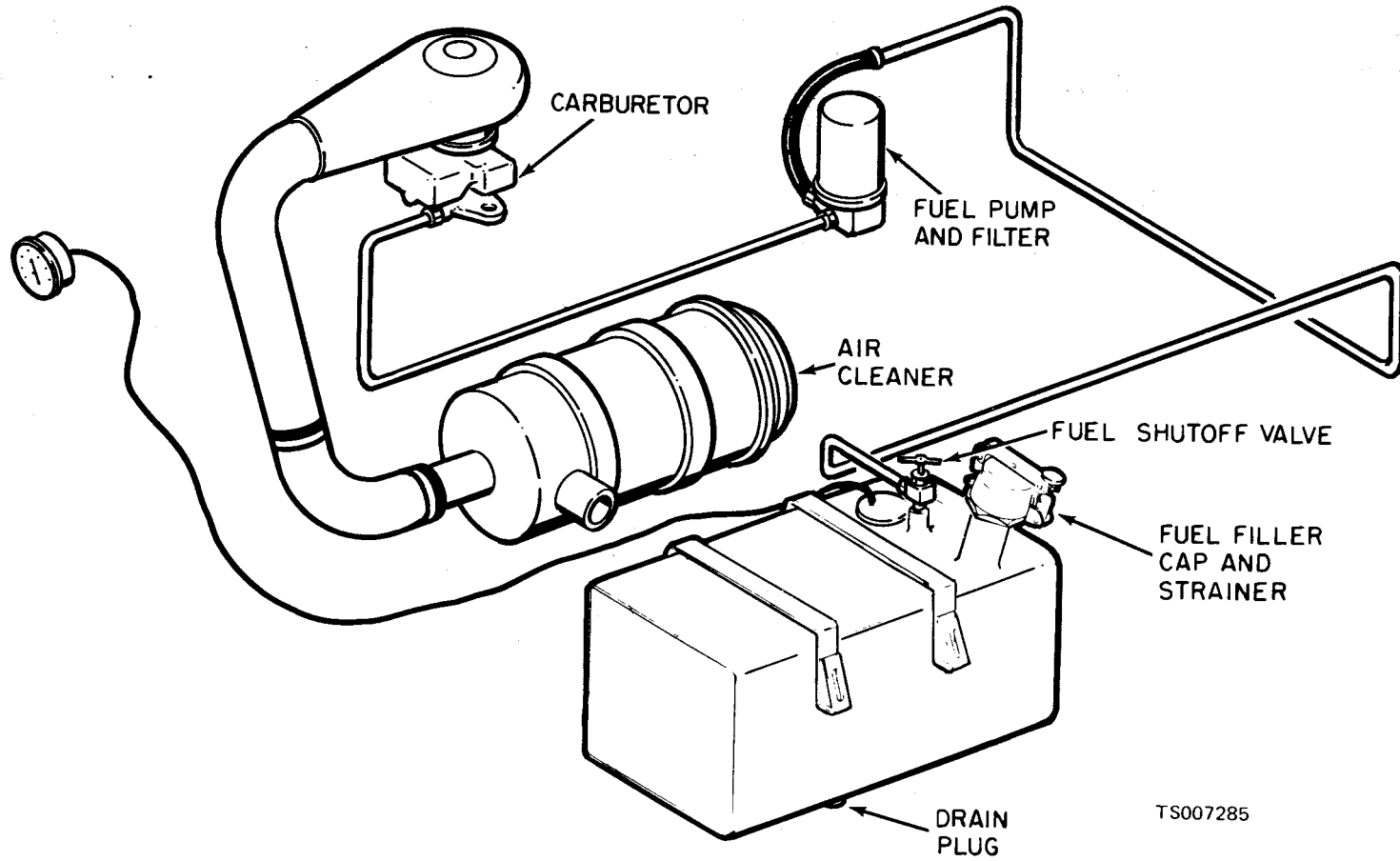

Figure 4-22. Fuel System

### 4-47. Fuel Tank Replacement

a. *General.* The fuel tank is mounted at the right side of the vehicle, and is secured to the frame by means of two metal straps.

b. *Removal.* Refer to figure 4-28 and proceed as follows:

**WARNING**

Do not smoke or permit an open flame in the vicinity of the vehicle while draining the fuel tank. Provide ventilation to the

working area to prevent the build-up of potentially explosive vapors, and use extreme care when handling metal tools to avoid the possibility of sparks. Use a safety type fuel container to catch the gasoline as it is drained from the tank.

(1) Remove filler cap and strainer (6) by unscrewing from fuel tank filler neck. Remove filler neck seal (7).

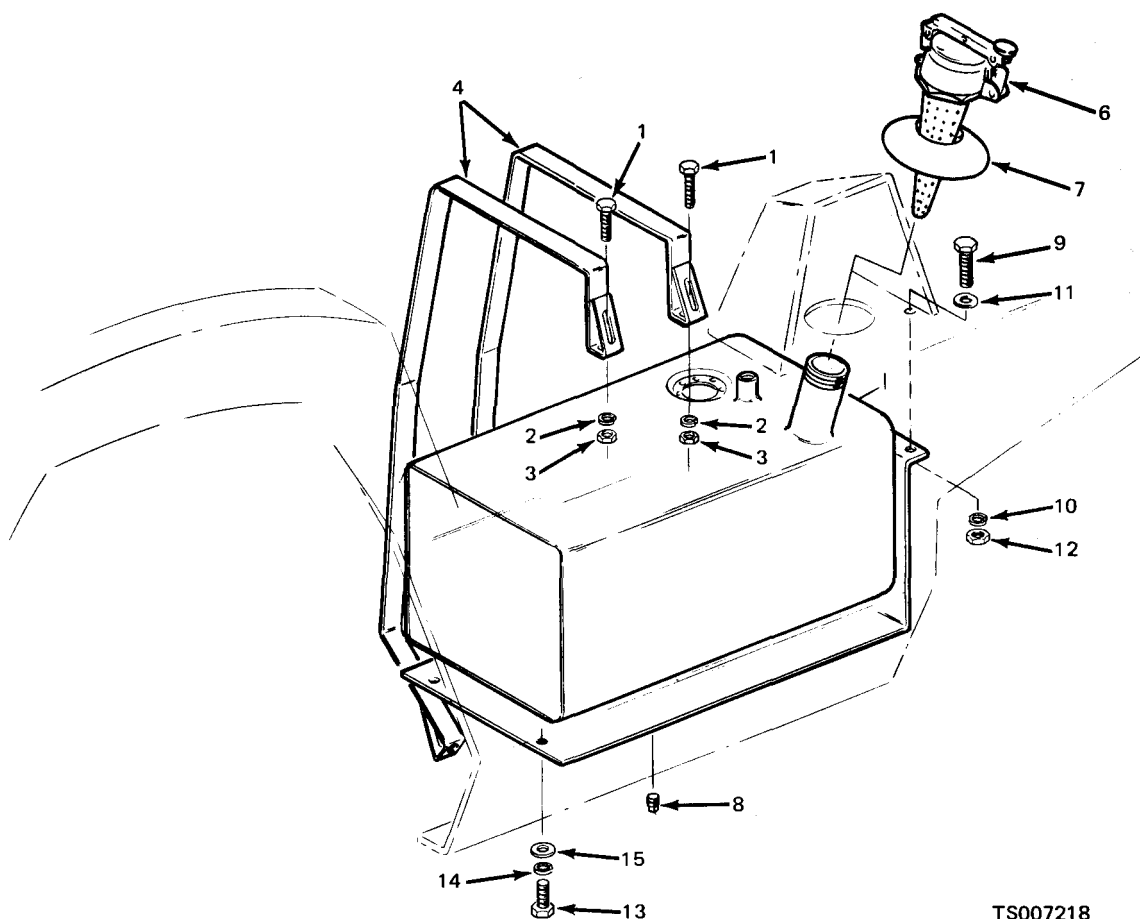

TS007218

- 1. Screw
- 2. Lockwasher
- 3. Nut
- 4. Strap

- 5. Fuel tank
- 6. Filler cap
- 7. Seal
- 8. Drain plug

- 9. Screw
- 10. Lockwasher
- 11. Washer
- 12. Nut

- 13. Screw
- 14. Lockwasher
- 15. Washer
- 16. Strainer

Figure 4-23. Fuel Tank Installation

(2) Remove plug (8) and allow tank to drain completely. Flush tank with hot water or steam.

(3) Unscrew and remove fuel shut-off valve from the standpipe on top of the tank.

(4) Remove machine screws and lift out sending unit from top of tank.

(5) Remove screws (1), securing straps (4), and remove fuel tank (5) from frame.

*c. Replacement.*

(1) Be sure the new or repaired tank is free of dust, dirt, metal chips or preservative material. Steam clean the interior and dry thoroughly if tank cleanliness is doubtful.

(2) Position tank (5) against the right side of the frame, and wrap straps (4) around tank. Secure ends of straps by installing screws (1), washers (2) and nuts (3).

(3) Make certain drain plug (8) is in place in bottom of tank and is tight.

(4) Install fuel sender and gasket to top of tank and secure with machine screws.

(5) Install fuel shutoff valve and connect fuel line. Make certain that fuel shut-off valve is open.

(6) Install filler neck seal (7) and filler cap (6) to fuel tank filler neck.

**4-48. Fuel Line Replacement and Repair**

*a. General.* The fuel lines consist of a shut-off valve, mounted at the fuel tank, a length of metal tubing to carry fuel to the fuel filter and pump assembly, rubber hose and clamps used to

connect the tank supply line to the fuel pump and filter, and a tube assembly with connectors to carry the fuel from the fuel pump to the carburetor.

*b. Repair.* Repair to a damaged fuel line can be made by cutting out the cracked or kinked section and bridging the resulting gap with a length of rubber hose of appropriate size and fitted with hose clamps. This type of repair should only be made on the low pressure supply line from the tank to the pump and filter. The only practical repair for other parts of the fuel lines is replacement of the defective part.

*c. Replacement.* Refer to figure 4-24 and proceed as follows:

(1) Unscrew the fuel line fitting at the fuel shut-off valve (2). Unscrew and remove valve (2) from the tank.

(2) Hose (4) may be replaced by loosening clamps (3) at fuel line and fuel pump.

(3) When installing a new valve (2), make certain it is in the open position after fuel line (1) is hooked up.

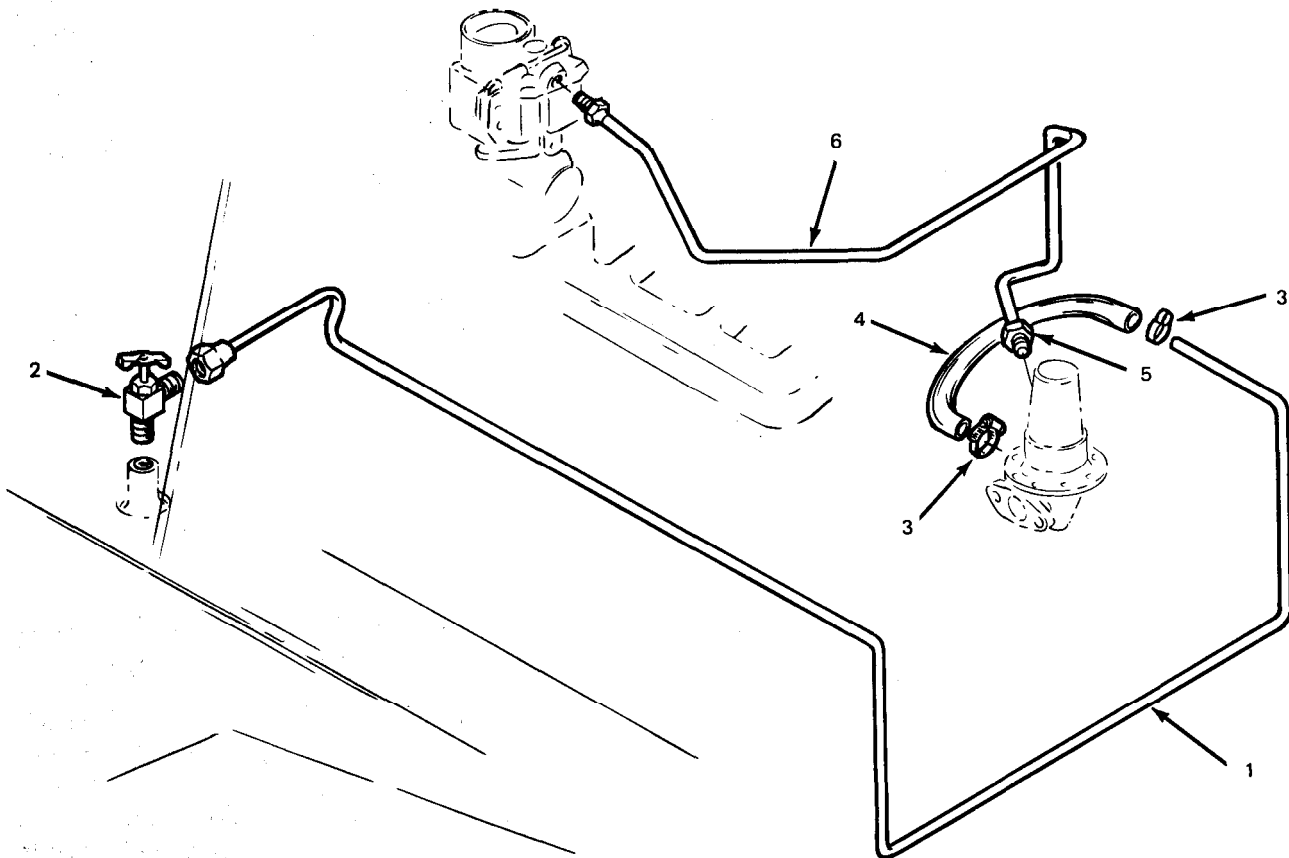

TS007219

1. Fuel line  
2. Shut-off valve

3. Hose clamp  
4. Rubber hose

5. Adapter  
6. Tube assembly



#### 4-49. Fuel Pump

The fuel pump is mounted on the lower left center of the engine cylinder block. The pump is of the mechanical diaphragm type, and is operated by the rocker arm which rides on an eccentric of the camshaft.

The fuel pump incorporates a replaceable filter element which filters suspended particles out of the fuel before it reaches the fuel pump. This filter element is replaced every 500 operating hours.

#### 4-50. Fuel Pump Tests

*a. General.* To determine that the fuel pump is in satisfactory operating condition, tests for both fuel pump pressure and fuel pump capacity (volume) should be performed. The tests are

performed with the fuel pump installed on the engine and the engine at normal operating temperature at idle speed.

##### NOTE

Before the tests, make sure the replaceable fuel filter has been changed within the recommended maintenance interval. When in doubt, install a new filter. Refer to paragraph 4-47.

##### *b. Pressure Test.*

(1) Remove the air cleaner assembly. Disconnect the fuel inlet line or the fuel filter at the carburetor. USE CARE TO PREVENT COMBUSTION DUE TO FUEL SPILLAGE.

(2) Connect a pressure gage, a restrictor and a flexible hose between the fuel filter and the carburetor, as shown in figure 4-25.

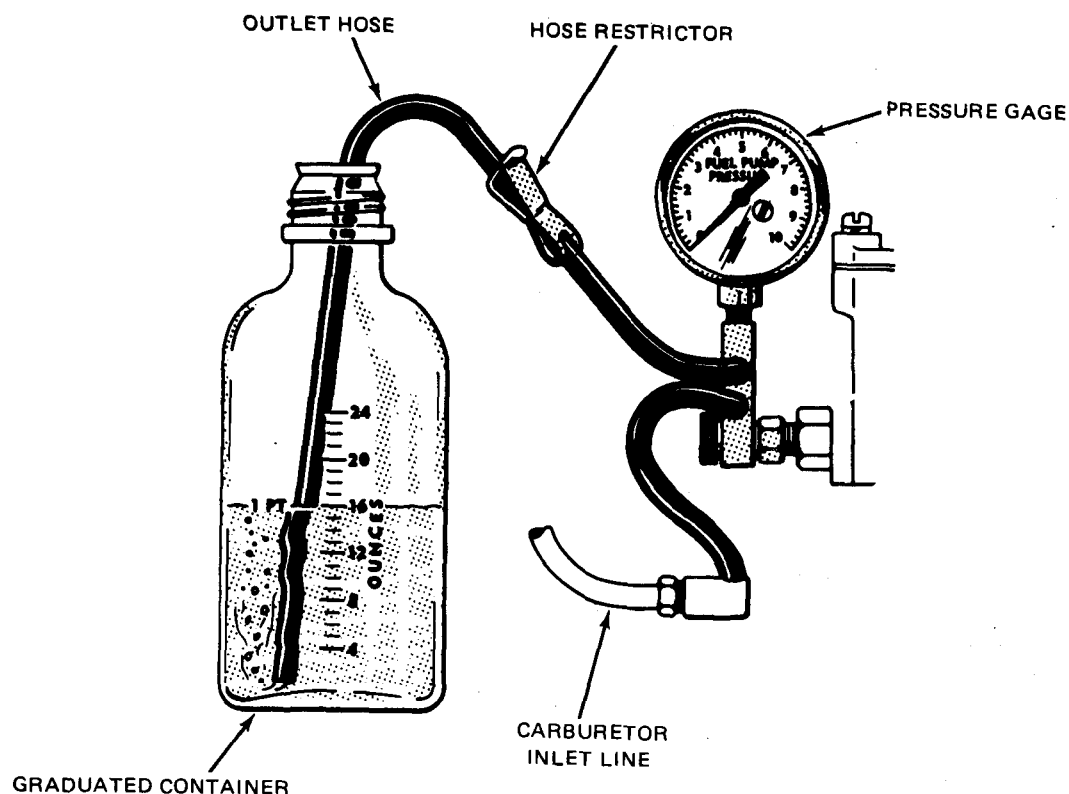

TS007286

Figure 4-25. Fuel Pump Test Set-up

(3) Position the flexible hose and the restrictor so the fuel can be discharged into a suitable, graduated container.

(4) Before taking a pressure reading, operate the engine at 500 RPM and vent the system into the container by opening the hose restrictor momentarily.

(5) Close the hose restrictor, allow the pressure to stabilize, and note the reading, which must fall between 4.0 and 6.0 PSI.

(6) If the pump pressure is not within

specifications, and the fuel lines and filter are in satisfactory condition, the pump is defective and should be replaced.

(7) If the pump pressure is within specifications, perform the tests for fuel capacity (volume).

*c. Capacity (volume) Test.* With the fuel pump pressure within specifications, test the capacity (volume) as follows:

(1) Operate the engine at 500 RPM.

(2) Open the hose restrictor and expel the

fuel into the container while observing the time required to expel one pint. Close the restrictor. One pint or more of fuel should be expelled within 30 seconds.

(3) If the pump volume is below specifications, repeat the test using an auxiliary fuel supply and a new fuel filter. If the pump volume meets specifications while using the auxiliary fuel supply, check for a restriction in the fuel supply from the tank and for the tank not venting properly. If pump volume will not satisfy specifications, replace the entire pump assembly.

#### **4-51. Fuel Filter Service**

*a. General.* The fuel filter element should be replaced at each 500 hour interval and also whenever fuel contamination or element restriction is suspected as a cause for engine malfunction.

*b. Filter Replacement.* Refer to figure 4-26 and proceed as follows:

#### **WARNING**

Some fuel spillage will be unavoidable during filter replacement. Do not smoke or allow use of open flame in the vicinity during this procedure.

(1) Unscrew the filter housing from the fuel pump, and remove the filter element and gasket. Discard the element and gasket. Clean the filter housing in cleaning solvent.

(2) Place a new filter element over the spout in the fuel pump valve housing cover. **BE SURE TO USE THE PROPER TYPE ELEMENT FOR THE INSTALLATION.** Coat a new gasket with light engine oil and position the gasket on the filter housing. Screw the filter housing onto the fuel pump. Hand tighten the filter housing until the gasket contacts the pump, and then advance it 1/8 turn.

(3) Start the engine and check for leaks.

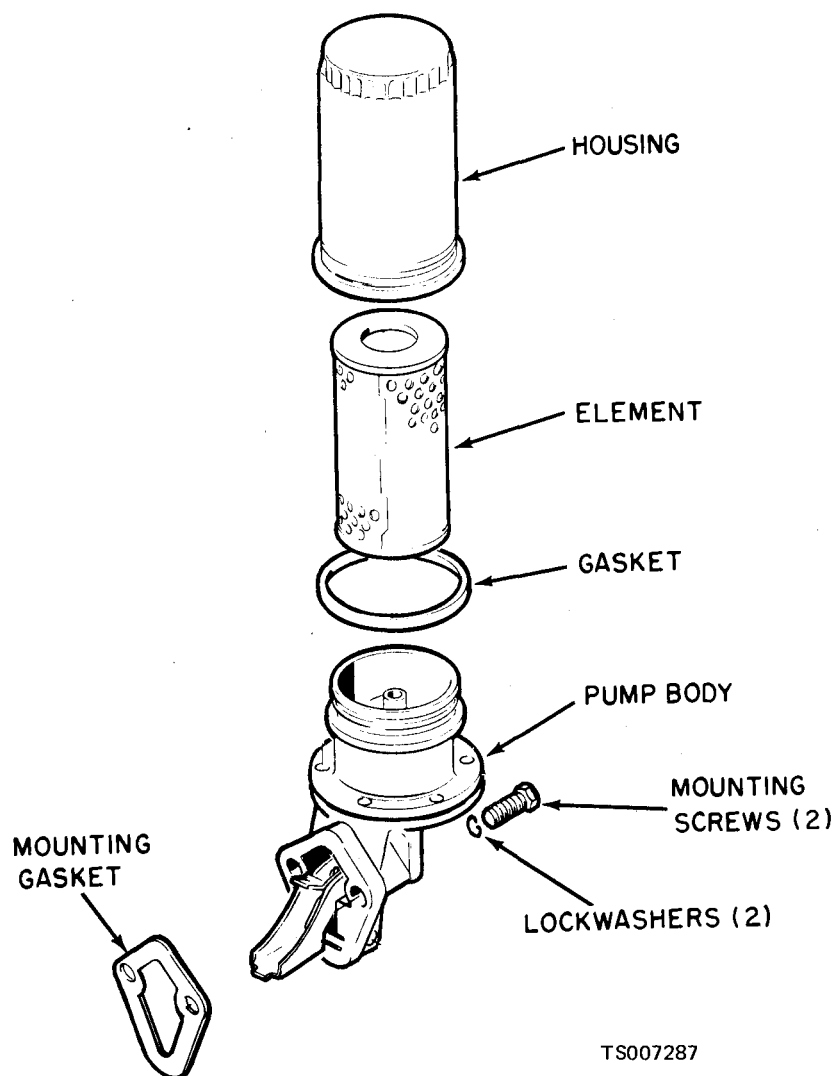

TS007287

Figure 4-26. Fuel Pump Assembly

#### 4-52. Fuel Pump Replacement

If fuel pump replacement is required, refer to figure 4-26. Disconnect the fuel inlet hose and the fuel line connector at the fuel pump body. Remove the two screws and lockwashers and remove the fuel pump from the engine. Scrape away all residue of the mounting gasket from the cylinder block surface. Using a new mounting gasket, install the replacement pump and secure with the mounting screws and lockwashers.

#### 4-53. Air Cleaner

*a. General.* The air cleaner assembly is mounted on the right side of the vehicle and is connected to the carburetor. The air intake system is sealed so that all air passing through the carburetor has been filtered through the

chemically treated paper element. A restriction indicator, mounted on the cowl, measures pressure loss to determine when the element should be cleaned or replaced. A red signal shows in the window of the indicator when the element requires cleaning or replacement.

*b. Maintenance.* The air cleaner restriction indicator will signal when the element is so restricted as to need cleaning or replacement. This indicator cannot determine when the element is damaged or ruptured. For this reason, the air cleaner element must be carefully inspected after each cleaning. It is very important that the air intake system ductwork be carefully checked for leaks at each quarterly interval, to prevent entry of unfiltered air to the engine.

#### 4-54. Air Cleaner Service

Refer to figure 4-27, showing parts of the air cleaner assembly, and service the air cleaner as follows:

a. *Dust Cup.* Empty and clean dust cup every 8 operating hours or more often under extremely dusty conditions. Dust should not be allowed to build up in cup. Remove foreign material such as leaves from around filter and tighten wing nut if necessary. Replace baffle and securely replace cup on air cleaner body.

b. *Filter Element Removal.* Proper servicing means cleaning unit thoroughly and maintaining airtight connections between the air cleaner and intake manifold so that all air entering the engine is filtered. Remove the filter element for cleaning as follows:

- (1) Remove cover.
- (2) Lift out baffle.
- (3) Empty dust from cup.
- (4) Remove filter element. Clean thoroughly

by using one of the following methods.

c. *Cleaning a Dusty Element.* Use compressed, dry filtered air directing this up and down pleats on the clean side of the element.

#### CAUTION

**Air pressure must not exceed 100 PSI. Maintain a reasonable distance between nozzle and element. Direct air through element (opposite to direction of arrows cast on end of element). Do not damage fins or se sling surfaces or rupture element nor allow dust to deposit on clean air side.**

d. *Cleaning an Oily or Sooty Element.* For best results, use small amount of cool tap water with non-sudsing household detergent then add to warm (70° - 100° F, 21° C - 38° C) water. The warmer the solution the better the cleaning. Soak for approximately 15 minutes. Rinse element thoroughly with clean water from hose (maximum pressure 40 PSI). Air dry completely before installing.

e. *Element Installation.* After air cleaner has dried, (a fan or air draft may be used, but do not heat element to hasten drying) inspect element for damage by placing a bright light inside element. Thin spots, pin holes or the slightest rupture will render the element unfit for further use.

(1) Clean cover, baffle and inside of filter body with a clean lint free cloth.

(2) Check air cleaner hose connections for an airtight fit.

- (3) Install filter element making sure wing nut is tight.
- (4) Replace baffle.

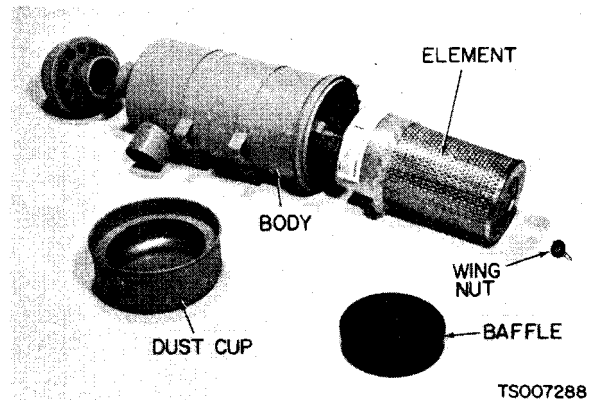

Figure 4-27. Air Cleaner Assembly

#### 4-55. Air Cleaner and Ductwork Replacement

If parts of the air cleaner body or system ductwork become damaged or deteriorated to the point that they will not form an airtight seal against entry of unfiltered air, these parts must be replaced. Refer to figure 4-28 and remove the parts to be replaced as shown in the illustration. When installing new parts, maintain the parts relationship depicted in the illustration.

KEY to fig. 4-28:

1. Air cleaner assembly
2. Clamp
3. cup
4. Baffle
5. Wing nut
6. Washer
7. Element and gasket
8. Screw
9. Nut
10. Washer
11. Lockwasher
12. Clamp
13. Clamp
14. Hose
15. Nut
16. Screw
17. Clamp
18. Elbow
19. Clamp
20. Tube
21. Wing nut
22. Washer
23. Adapter
24. Clamp
25. Adapter
26. Restriction indicator
27. Elbow
28. Nipple
29. Coupling
30. Adapter
31. Hose

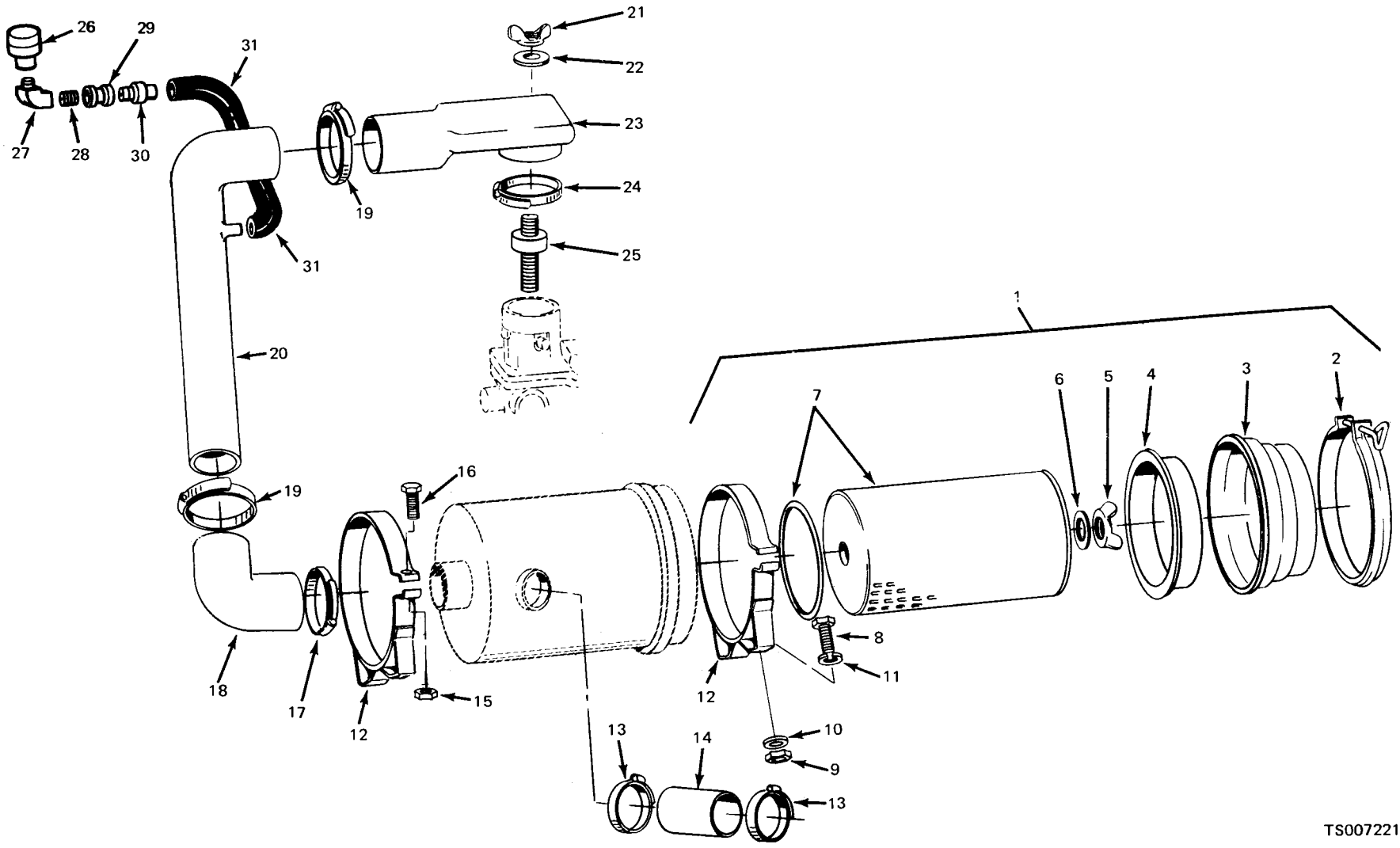

Figure 4-28. Air Cleaner Installation

#### 4-56. Carburetor

*a. General.* The carburetor consists of three main assemblies; the air intake body, main body and the throttle body. The air intake body, which serves as the main body cover, contains the choke plate, vent tube, and float and lever assembly. The anti-stall dashpot is bracket-mounted to the air intake body. The main body contains the accelerator pump assembly, metering rod jet, low-speed jet, accelerator pump check ball and weight, an anti-percolator bleed and the main discharge nozzle. The throttle body contains the throttle plate, throttle shaft and lever and idle mixture adjusting screw with a plastic limiter cap and choke connector rod (manual choke carburetors).

*b. Operation.* The engine speed is regulated and controlled by a proportion of fuel and air delivered to the cylinders for all engine operating conditions. Operation is based on the principle of pressure differences. Air is drawn into the carburetor air horn by manifold vacuum. As the air passes through the carburetor on the way to enter the cylinders, low pressure is created at the fuel discharge outlets of the carburetor. The fuel bowl is vented to the air intake body. The high air pressure exerted on the fuel in the bowl forces the fuel to travel up through the fuel discharge channels and out into the air stream passing through the carburetor. The fuel and air is mixed at the point and distributed into the engine cylinders for combustion.

#### 4-57. Carburetor Adjustment

Before attempting carburetor adjustment, check the condition of the following:

*a. Spark Plugs.* See that plugs are correct type, clean, and have correct gap.

*b. Distributor Points.* See that points are clean, in good condition and properly set.

*c. All High Tension Terminals.* See that terminals are making good contact at plugs and at distributor cap and the coil towers.

*d. Carburetor.* Check that carburetor is securely mounted to manifold, and that no fuel or air leakage is evident.

*e. Adjustment.* Before making idle speed adjustment, have the engine warmed up. For best results, use a tachometer to determine engine speed during these adjustments. Refer to figure 4-29 and proceed as follows:

(1) Turn the idle speed screw in or out to obtain 500 RPM reading on the tachometer. Be sure that the choke valve is fully open and that the fast idle adjusting screw is not contacting the cam.

(2) Adjust the idle mixture screw to obtain the highest RPM. While making the adjustment, carefully watch the tachometer and notice that the speed can be decreased by turning the screw in either direction from the setting that gave the highest RPM reading.

(3) From the highest idle speed setting, turn the mixture screw clockwise (leaner) until the speed starts to drop. Turn the screw in the opposite direction (counterclockwise) just far enough to recover the speed that was lost.

#### NOTE

This procedure will assure that the idle has been set to the leanest mixture possible for smooth idle. This setting is very important.

(4) Since the correct speed was originally set using the speed screw, the speed obtained after finding the leanest smooth idle setting will probably be too fast.

(5) Readjust the speed screw to obtain correct idle speed. Repeat steps (2) and (3) above.

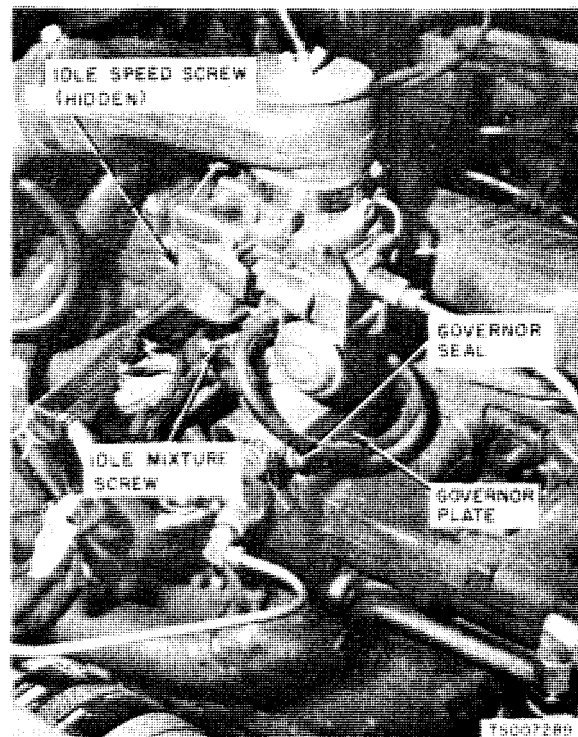

Figure 4-29. Carburetor adjustments

#### 4-58. Carburetor Replacement

*a. General.* Flooding, stumble on acceleration and other performance complaints are, in many instances, caused by the presence of dirt, water, or other foreign matter in the carburetor. To aid in diagnosing the complaint, the carburetor should be carefully removed from the engine without removing the fuel from the bowl. The

contents of the bowl may then be examined for contamination as the carburetor is disassembled.

*b. Removal.* Refer to figure 4-29 and proceed as follows:

(1) Remove the air intake elbow from the carburetor.

(2) Disconnect the throttle return spring, throttle cable, choke control cable and housing, fuel inlet line, and the distributor vacuum line from the carburetor.

(3) Remove the two hex nuts from the mounting studs, and remove the carburetor assembly.

*c. Replacement.*

(1) Clean the gasket mounting surface of the carburetor intake manifold and velocity-type governor.

(2) Install the governor mounting gasket, governor, spacer lower gasket, spacer upper gasket and the carburetor on the intake manifold.

(3) Connect the governor tube to the carburetor. Install distributor vacuum line to the governor.

(4) Install and tighten hex nuts over carburetor mounting studs. Tighten nuts evenly and alternately.

(5) Connect the throttle control cable, throttle return spring and the choke control cable to the carburetor.

(6) Adjust the idle fuel mixture and engine idle speed to specification as outlined in paragraph 4-57.

(7) Install the air cleaner inlet elbow on the carburetor air inlet body.

#### 4-58.1. Carburetor Repair

*a. Removal.* Refer to paragraph 4-58 and remove the carburetor assembly from the engine.

*b. Disassembly.* Refer to figure 4-29.1 for parts identification and proceed as follows:

(1) Disconnect and remove the fast idle rod, and the pump operating link. Unscrew and remove the dashpot assembly from its bracket.

(2) Remove the bowl cover screws, bowl cover, choke bracket, and dashpot bracket.

(3) Remove the pump rod clamp screw, pump rod and clamp from the bowl cover.

(4) Remove choke plate screws and plate. Pull choke shaft and lever out of bowl cover, and remove choke lever spring and control lever.

(5) Remove throttle body screws and separate main body from throttle body.

(6) Remove throttle plate screws and plate from throttle body bore. Remove nut, lockwasher, pump operating lever, bushing and spring from throttle shaft.

(7) Pull throttle shaft out of throttle body. Remove throttle adjusting screw and spring. Remove idle adjusting needle and spring.

(8) Remove float shaft retainer, hinge shaft, and float assembly from main body. Remove pump drive spring, piston stem, and piston cup.

(9) Remove power valve piston assembly from main body. Remove fast idle cam screw and fast idle cam.

(10) Remove spark valve and gasket, fuel inlet and needle seat, and spark fitting. Remove pump discharge valve weight and discharge valve ball. Remove power valve assembly. Remove main jet only if orifice appears burred, worn, or otherwise damaged. This completes recommended disassembly.

*c. Cleaning and Inspection.* Dirt, gum, water or carbon contamination on the exterior moving parts of a carburetor are often responsible for unsatisfactory performance. For this reason, efficient carburetion depends upon careful cleaning and inspection while servicing.

(1) Thoroughly clean carburetor castings and metal parts in carburetor cleaning solvent.

#### CAUTION

**Accelerator pump plunger and any fiber or rubber parts should never be immersed in carburetor cleaner. Wash pump plunger in cleaning solvent.**

(2) Blow out all passages in the castings with compressed air. Make sure all jets and passages are clean. Do not use wire to clean fuel passages or air bleeds.

(3) Check inlet valve needle and seat for wear. If wear is noted, the assembly must be replaced.

(4) Check float hinge pin for wear and check float for damage.

(5) Check throttle and choke shaft bores for wear and out-of-round.

(6) Inspect idle mixture adjustment needles for burrs or grooves; replace if damaged.

(7) Inspect cup of accelerator pump plunger; replace if damaged, worn, or hardened. Inspect pump well in bowl for wear or scoring.

(8) Check filter screens for dirt or lint. Clean, and if they remain clogged, replace.

(9) Check the three main castings carefully for damage such as nicks, burrs, or cracks, around gasket surfaces. Also check the condition and cleanliness of all threaded holes.

*d. Reassembly.*

#### NOTE

Always use new gaskets and seals when reassembling carburetor.

(1) Refer to figure 4-29.1 and reassemble the carburetor assembly as follows:

(2) Install the fuel inlet needle and seat, with gasket, into the main body. Install the spark valve and gasket, and the spark fitting.

(3) Install the fast idle cam, spring washer, and fast idle cam screw.

(4) Install power valve assembly, float and hinge assembly, float hinge shaft, and retainer.

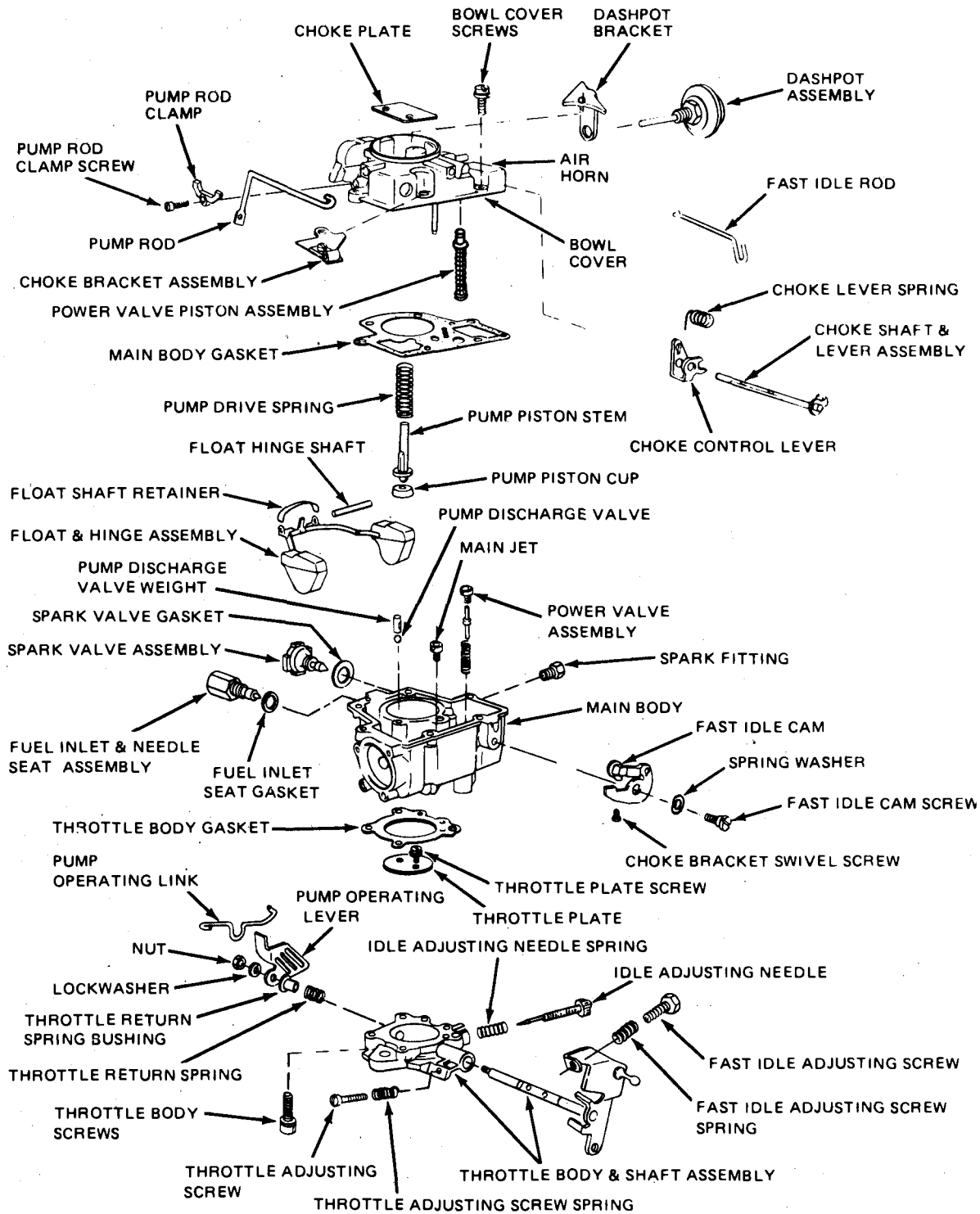

TA501872

Figure 4-29.1. Carburetor Assembly Exploded View

(5) With float installed as above, invert the body and check float position. A straightedge placed across the machined flanges of the bowl should just contact the toes of the float. If necessary, bend the

float tang (at the center of the shaft) to obtain this position.

(6) Install idle mixture adjustment needles and springs in throttle body. Tighten fingertight, then



unthread one turn as a preliminary adjusting setting. Install throttle shaft and plate.

### CAUTION

**Do not force idle mixture adjustment needles against seats, or damage may result.**

(7) Invert main body and place new throttle body gasket on bowl. Fasten throttle body to bowl body with screws and lockwashers; tighten securely.

(8) Install pump discharge valve ball and weight into main body. Install pump rod and bracket into bowl cover. Install power valve piston assembly.

(9) Install choke lever, choke shaft, and choke plate in the bowl cover. Assemble the accelerator pump piston to the pump rod inside the bowl cover. Install new main body gasket.

(10) Carefully lower bowl cover down over the main body, and check to see that accelerator pump plunger is guided properly into the well.

(11) Position choke bracket and dashpot bracket, and secure with bowl cover screws. Install remainder of bowl cover screws,

(12) Install fast idle rod and pump operating link, and fast idle screw,

#### e. Preliminary Adjustments.

(1) With throttle lever in the idle position, the distance from the edge of the vacuum passage casting to the center of the hole in the pump operating rod should be  $27/32$  inch as shown in figure 4-29.2. Bend pump rod to obtain proper dimension.

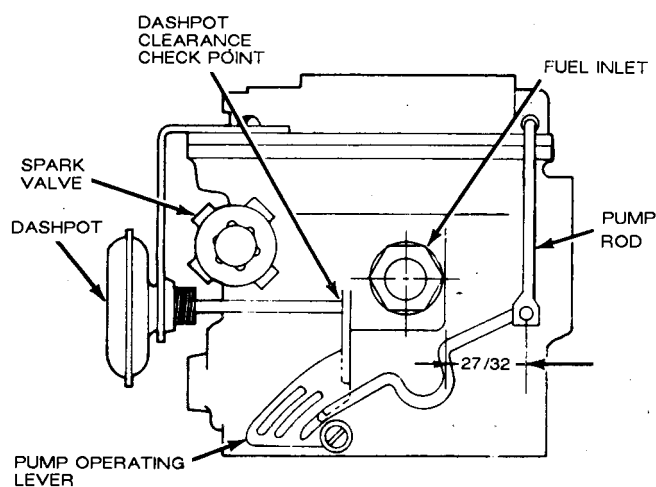

TA501873

Figure 4-29.2. Pump Adjustment

(2) With dashpot stem depressed and linkage set at idle speed,  $3/32$  clearance should exist between end of dashpot stem and tang on pump operating rod. See figure 4-29.2.

f. Installation. Refer to paragraph 4-58 and install carburetor. Make final carburetor adjustment after installation according to instructions in paragraph 4-57.

#### 4-59. Governor

a. General. The velocity governor is a single unit mounted between the carburetor and the intake manifold. The governor is operated by a combination of manifold vacuum and the air flow past the governor valves. The governor throttle valves are offset in the throttle bore so that the combined force of manifold vacuum and the fuel-air flow through the bores has greater effect on the larger, upstream area of the valves. This forces the throttle valves to move toward the closed position restricting the fuel-air flow. The closing action of the throttle valves is opposed by the control spring. The control spring is attached to the throttle valve shaft cam. The cam provides a balance between the closing action of the throttle valves and the action of the control spring at all engine speeds. Under operating conditions, the governor throttle valves do not close, but remain open enough to allow the required quantity of the fuel-air mixture to flow into the manifold to maintain the governed engine speed. To maintain the proper vacuum to the distributor, the governor has two interconnected vacuum transfer ports and a vacuum transfer plunger. When the governor throttle valves are forced toward the closed position, vacuum from the lower port is supplied to the distributor to maintain sufficient spark advance. When the governor throttle valves are open wide enough, the plunger shuts off the bottom port and the top port supplies vacuum to the carburetor distributor vacuum passage for sufficient vacuum to the distributor.

b. Adjustment. If engine governed speed is too low or too high, and governor setting is to be checked and adjusted, proceed as follows:

(1) Connect as tachometer to the engine. With the engine at normal operating temperature, operate the engine at wide open throttle and compare the RPM with the operating range of the governor. The operating range is stamped on the governor plate (see figure 4-29).

(2) If governed speed is within range, stop the engine and remove the tachometer.

(3) If adjustment is required or desired, remove the governor seal. To increase RPM, turn the cap counterclockwise. To decrease RPM, turn the cap clockwise. When adjustment is completed, stop the engine, seal the cap, and remove the tachometer.

c. Replacement. Governor removal and replacement procedures are given in paragraph 4-58. Governor and related parts are illustrated in figure 4-30. Perform governor adjustment after installation of new governor.

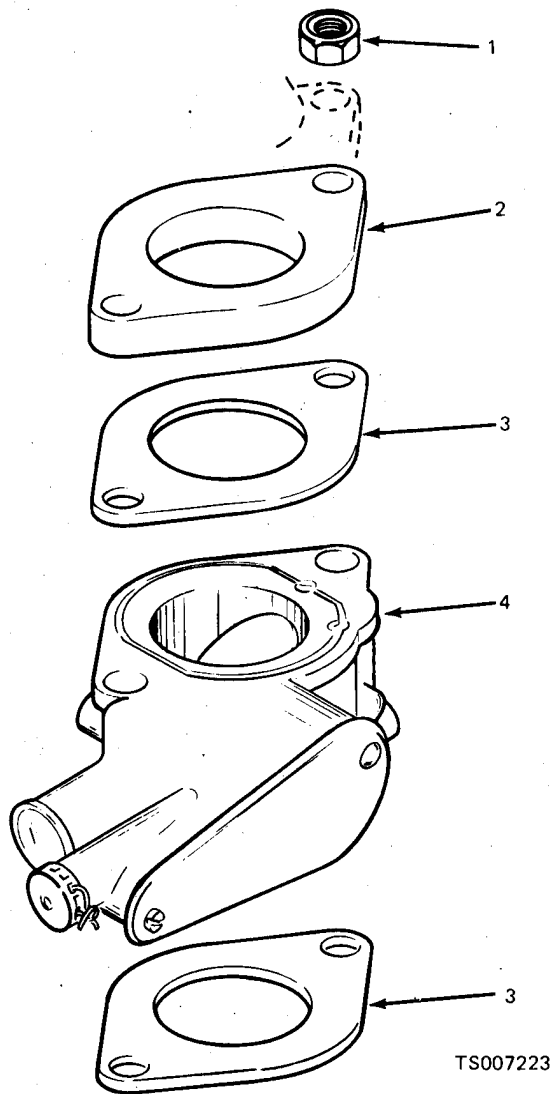

- 1. Nut
- 2. Adapter
- 3. Gasket
- 4. Governor

Figure 4-30. Governor Assembly

#### 4-60. Accelerator and Linkage

a. *General* The accelerator linkage consists of the pedal, a bell-crank lever, and a flexible push-pull control cable which is connected to the carburetor. Ball joints are provided at both ends of the push-pull cable to eliminate twisting, kinking, and binding. This linkage group also includes the manual push-pull choke control cable.

b. *Inspection and Adjustment.* The linkage and cable arrangement is properly adjusted when the vehicle leaves the factory. However, in time components will become worn and require adjustment to maintain smooth, even, control of engine speed. Proceed as follows:

(1) Check pedal and pedal lever for secure mounting. Make certain the nylon roller on the underside of the pedal is in good condition.

(2) Check ball joints at each end of cable for general condition and secure attachment.

(3) Check entire length of cable for kinks, permanently deformed bends, or pinched spots.

(4) Check clips, brackets and cable mountings for secure mounting.

(5) Check return spring for secure attachment and adequate tension to return linkage to idle when pedal is released.

(6) Disconnect the cable from the carburetor linkage at the ball joint connection to the main throttle lever.

(7) Adjust cable length by loosening the clip (29, fig. 4-29) and positioning cable so that carburetor reaches the full throttle position just as the accelerator pedal contacts the floor board. Reconnect cable to carburetor throttle linkage.

(8) After adjustment, make certain that cable clips and attaching points are secure and properly aligned.

c. *Replacement.* Refer to figure 4-31 for parts relationship of the accelerator linkage parts, and remove and replace parts as shown in the exploded view.



misaligned hanger supports. These vibrations can be eliminated by loosening the clamps and changing position so that the exhaust pipe, muffler, and tail pipe will be in proper alignment, free of contact with the frame or body.

*b. Replacement.* Refer to figure 4-32 and proceed as outlined in the following paragraphs:

(1) *Exhaust Pipe.* Remove the nuts securing the exhaust pipe (23) to the exhaust manifold. Loosen and disconnect mounting clamp (19) as necessary. Loosen clamp (14) securing exhaust pipe to muffler and remove exhaust pipe (23) and (20).

NOTE

Always use new gasket (24) between exhaust pipe (23) and exhaust manifold. After installation of exhaust pipe, check the exhaust system for alignment and leaks.

(2) *Muffler.* Disconnect the support bracket and clamps (13) on each side of the muffler. Loosen the tail pipe support clamp bolt (1) and pull the tail pipe (6) down until it is free of the muffler. Remove the muffler (15). To install the muffler, reverse the above steps and properly align the complete system, then tighten connecting support brackets securely. Operate the engine and check for possible leaks.

(3) *Tail Pipe.* Disconnect the support bracket and clamps (4) and (5) both at the rear of the muffler and also at outlet end of the tail pipe (6). Free the tail pipe from the muffler (15). To assemble, position tail pipe to the muffler and secure clamps, being careful to align the exhaust system so it doesn't contact body or frame. Check system for exhaust gas leaks.

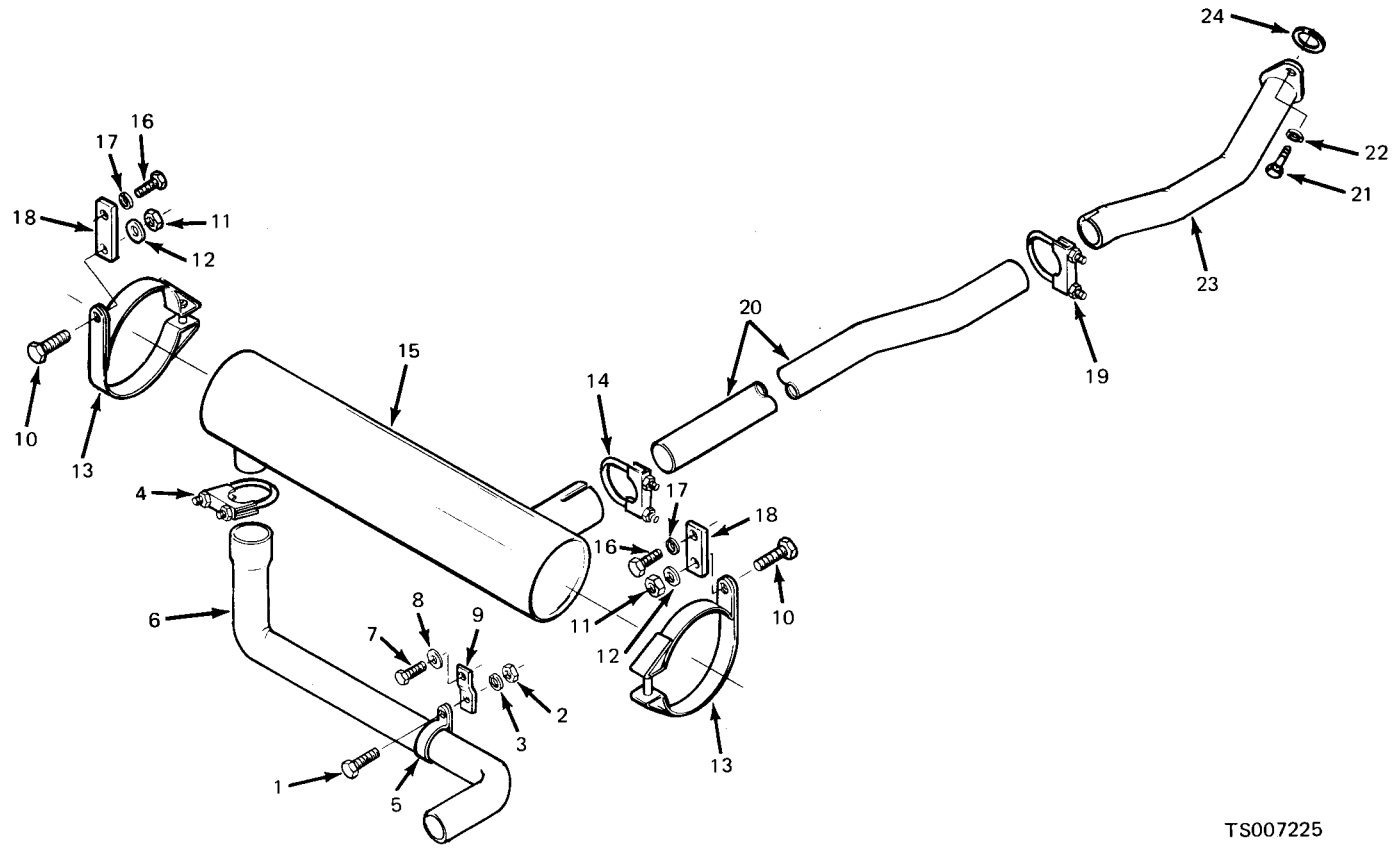

TS007225

- 1. Screw
- 2. Nut
- 3. Lockwasher
- 4. Ciamp
- 5. Ciamp
- 6. Tailpipe

- 7. Screw
- 8. Washer
- 9. Strap
- 10. Screw
- 11. Nut
- 12. Lockwasher

- 13. Ciamp
- 14. Ciamp
- 15. Muffier
- 16. Screw
- 17. Lockwasher
- 18. Strap

- 19. Ciamp
- 20. Rear exhaust pipe
- 21. Screw
- 22. Lockwasher
- 23. Exhaust pipe
- 24. Gasket

Figure 4-32. Exhaust System

Section XII. MAINTENANCE OF COOLING SYSTEM

**4-63. General**

a. The cooling system is of the pressurized type and utilizes a tube and fin type radiator. The coolant is drawn from the bottom of the radiator by the water pump, which circulates the coolant through the engine block. As the coolant enters the block, it travels through cored passages to cool the entire length of each cylinder wall. Upon reaching the rear of the cylinder block, the coolant is directed upward into the cylinder head where it cools the combustion chambers, valves and valve seats on its return to the front of the engine.

b. At the front of the engine, the coolant flows into the coolant outlet connection, past the thermostat if it is open, and into the top radiator header tank. If the thermostat is closed, a small portion of the coolant is returned to the water pump for recirculation. The entire system is pressurized at 12-15 PSI.

**4-64. Hoses and Thermostat**

a. *Inspection of Hoses.* Air, heat, and water deteriorate radiator hoses in two ways: by hardening or cracking which destroys flexibility and causes leaks; by softening and swelling which produces lining failure and hose rupture and clogging. Examine hoses spring and fall for possible need of replacement or tightening. If hoses are collapsed, cracked, or indicate a soft condition on the inside, they should be replaced.

b. *Replacement of Hoses.* Refer to figure 4-33 for parts relationship of cooling system parts. When installing a new hose, clean the pipe connections and apply a thin layer of nonhardening sealing compound. Hose clamps should be properly located over the connections to provide secure fastening. The pressurized cooling system pressure can blow off improperly installed hoses.

c. *Thermostat.* The cooling system of the engine is designed to provide adequate cooling under most adverse conditions. However, it is necessary to employ some device to provide quick warming and to prevent overcooking during normal operation. Automatic control of engine operating temperature is provided by a water flow control thermostat installed in the water outlet.

The thermostat is a heat-operated valved. It should always be maintained in working order and the vehicle should never be driven without one installed, as there would then be no control of engine temperature. The temperature at which the thermostat opens is preset and cannot be altered.

d. *Thermostat Test and Replacement.* When the thermostat is not operating properly, the engine may run too hot or too cold. Overheating may damage the thermostat so that its valve will not function properly, and a cold engine will not achieve full efficiency. Rust can also interfere with thermostat operation. To test the thermostat, place it in water heated approximately 250 F. (17 ° C.) above the temperature stamped on the thermostat valve. Submerge the bellows completely and agitate the water thoroughly. The valve should open fully. Next, place the thermostat in water heated approximately 100 F. (11 ° C.) below the temperature stamped on the thermostat valve. Submerge the bellows completely and agitate the water thoroughly. The valve should close completely. If the thermostat fails either of these tests, it should be replaced with a new one of the same type and rating.

KEY to fig. 4-33:

1. Clamp
2. Upper hose
3. Screw
4. Water outlet elbow
5. Clamp
6. Cap
7. Gasket
8. Thermostat
9. V-belt set
10. Clamp
11. Lower hose
12. Drain cock
13. Radiator cap
14. Screw
15. Nut
16. Rubber mount
17. Washer
18. Washer
19. Washer
20. Band strap
21. Radiator

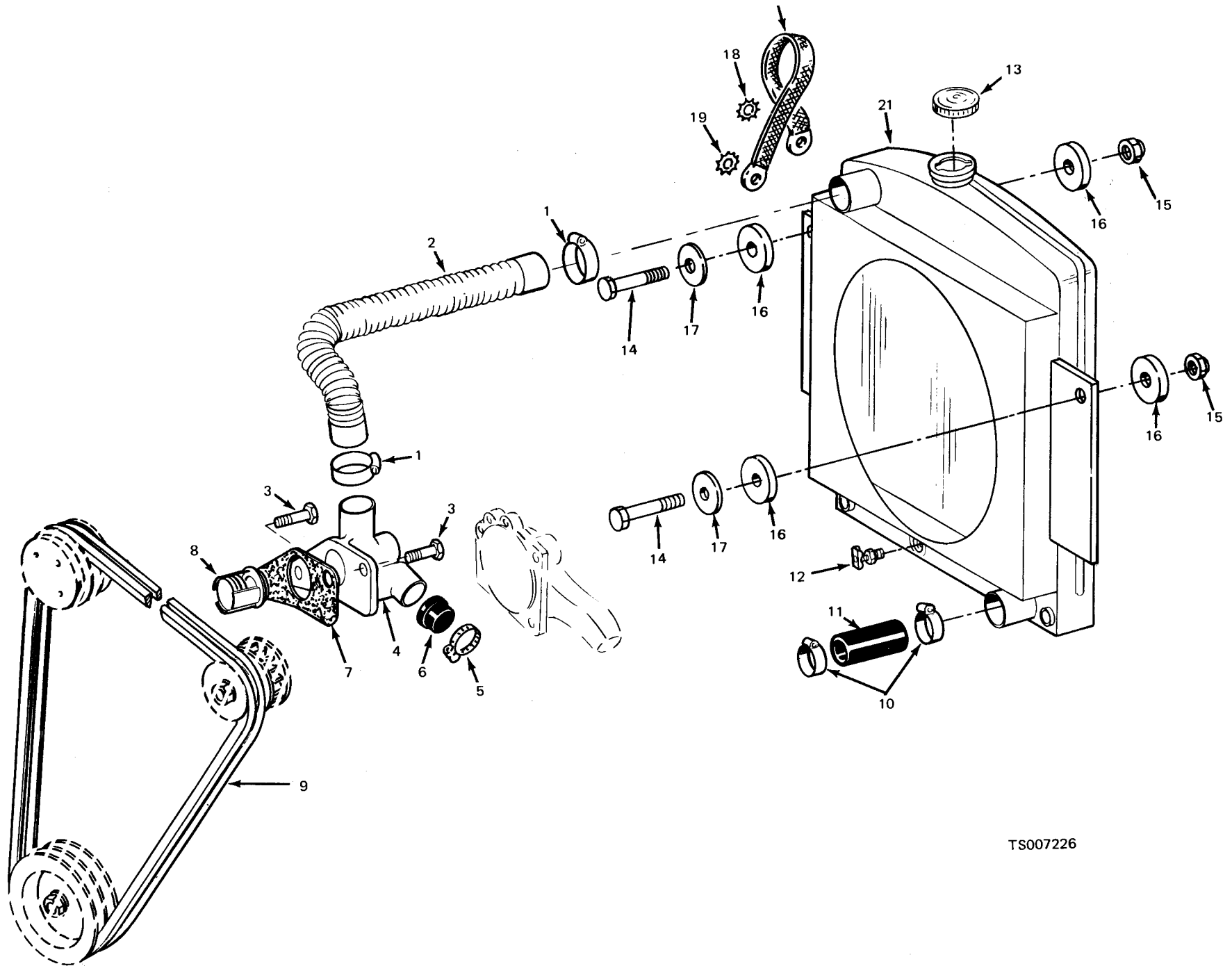

TS007226

Figure 4-33. Cooling System

**4-65. Water Pump**

*a. General.* The centrifugal-type water pump is mounted on the front of the cylinder block, and is driven from the crankshaft damper by pulleys and a V-belt. A vane-type impeller in the water pump supplies coolant, through centrifugal action, to the water pump outlet port. The water pumps have a double row sealed ball bearing, integral with the water pump shaft. The bearing requires no lubrication. A bleed hole in the water pump housing allows water that may leak past the seal to be thrown out by the slinger. The cooling fan hub is pressed a specified distance onto the water pump shaft.

*b. Operation.* Coolant enters the water pump at its center. Centrifugal force then forces coolant radially outward, through vanes of the pump impeller, and backward through the pump outlet port.

*c. Inspection.* Check the water pump for leaks, and excessive end play or looseness of the shaft in the pump. A quick way to check is to work the fan blades up and down by hand. If any play is noticed, this indicates that the bearings are rough. Rough bearings should be checked to see if the water pump should be replaced or rebuilt.

*d. Removal.* Refer to figure 4-34 and proceed as follows:

- (1) Drain the cooling system.
- (2) Disconnect lower hose from the water pump outlet fitting.
- (3) Remove fan from fan hub on water pump shaft. Loosen alternator mounting bolts and remove V-belts.
- (4) Remove capscrews (1) and lockwashers (2) securing pump assembly to cylinder block, and remove the pump assembly (3) and gasket (5).

(5) Remove pulley hub (6), using a bearing puller or an arbor press.

(6) Remove pipe plug (4) from housing.

(7) Remove shaft and bearing assembly (7) from the rear of water pump housing, with impeller (8) still assembled.

(8) Using a bearing puller or arbor press, remove impeller (8) from shaft and bearing assembly (7).

(9) Removal seal (9) from shaft and bearing assembly (7).

*e. Replacement.*

(1) Install seal (9) on shaft and bearing assembly (7).

(2) Use an arbor press to install impeller (8) onto shaft and bearing assembly (7).

(3) Install shaft and bearing assembly (7) into rear of water pump housing.

(4) Using an arbor press, install pulley hub (6) onto shaft extension.

(5) Install pipe plug (4) into housing.

(6) Coat a new gasket (5) on both sides with water-resistant sealer and position it on the cylinder block.

(7) Position the water pump (3) in place and install the lockwashers (2) and retaining bolts (1).

(8) Connect the radiator lower hose to the water pump.

(9) Install the water pump pulley and fan. Torque the bolts to 12-15 ft/lb.

(10) Install V-belts and tighten to specifications.

(11) Connect upper radiator hose to radiator and tighten clamps.

(12) Refill cooling system.



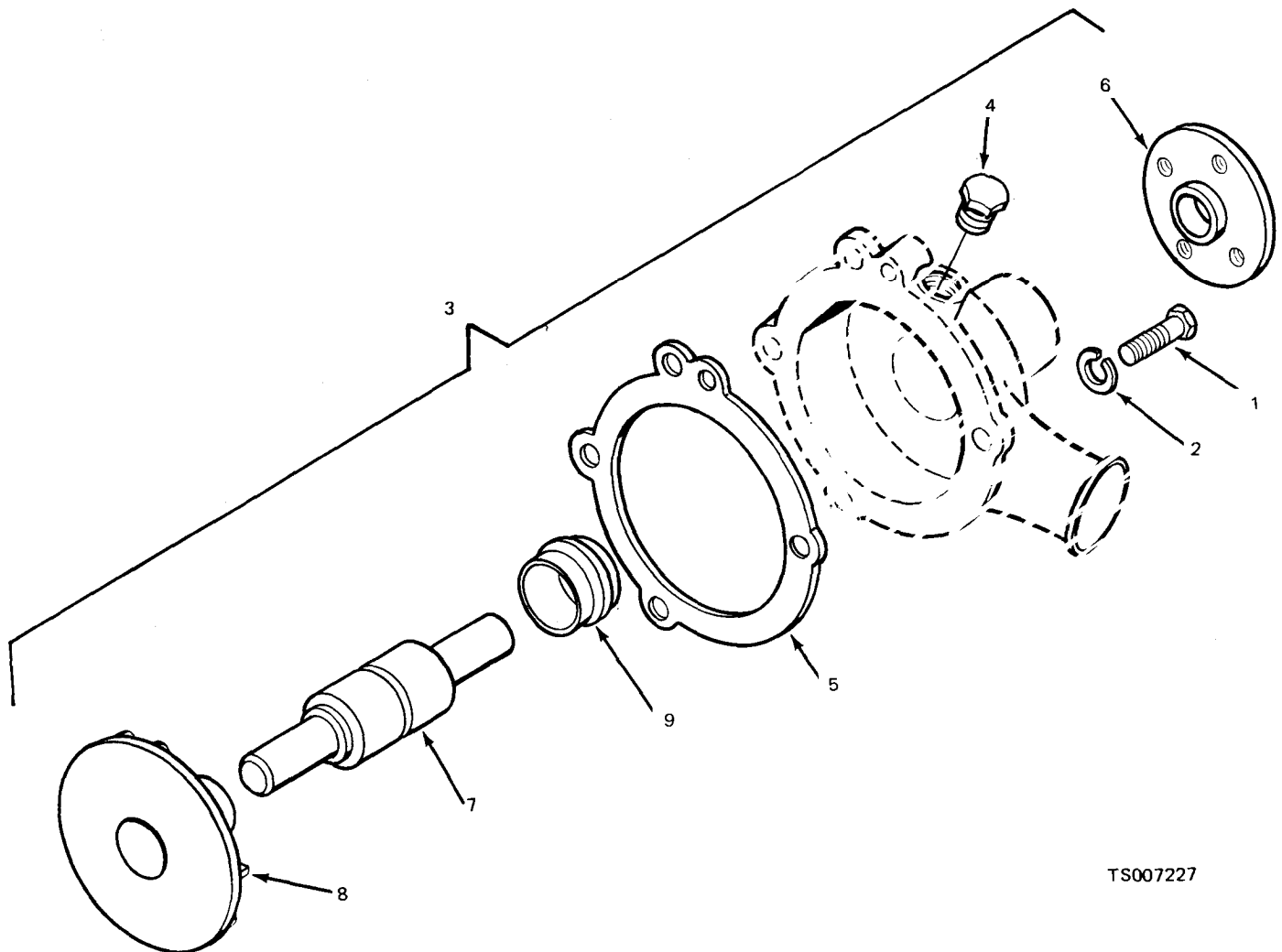

TS007227

- |                        |                               |
|------------------------|-------------------------------|
| 1. Screw               | 5. Gasket                     |
| 2. Lockwasher          | 6. Pulley hub                 |
| 3. Water pump assembly | 7. Shaft and bearing assembly |
| 4. Pipe plug           | 8. Impeller                   |
|                        | 9. Gasket                     |

Figure 4-34. Water Pump

**4-66. Fan and Alternator Belts**

*a. General.* The fan, water pump, and alternator are driven by a matched set of two V-belts. A fan belt that is too tight will cause rapid wear of the alternator or generator and water pump bearings. If the belt is too loose, it may slip, preventing the water pump from properly cooling the engine or the generator or alternator from properly charging the electrical circuit. The fan belt is properly adjusted when it can be deflected 1/2-inch (13 mm.) with 25 lbs pressure applied midway between the fan and alternator pulleys. Check this adjustment and inspect the condition

of the fan belt at each engine lubrication period. It is good preventive maintenance to replace a badly frayed, worn or cracked fan belt before it breaks in operation.

*b. Replacement and Adjustment.* Refer to figure 4-35 for details of belt adjustment. To replace the fan belt, loosen the attaching bolts at each generator or alternator brace-to-engine mounting and pivot the alternator toward the engine to gain slack needed to install the new belt. Remove the old belt. Position the new belt over the fan pulley, over the crankshaft pulley, then over the alternator pulley. Pull the alternator

away from the engine until belt tension is firm. Then tighten the alternator mounting bolts and check the tension as indicated above. Reset the alternator as necessary for correct belt tension. Finally, torque the alternator mounting bolts 25 to 35 ft/lb.

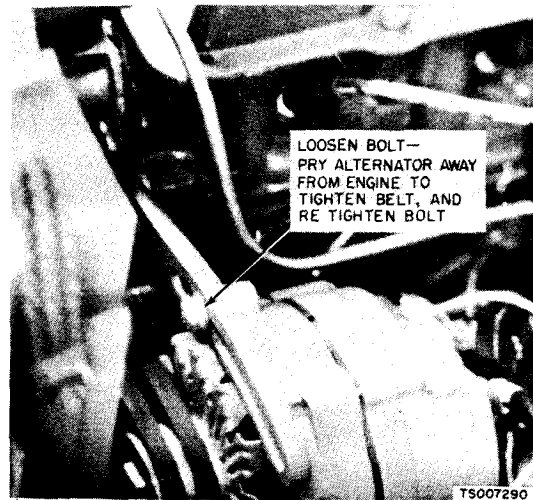

Figure 4-35. Belt Tension Adjustment

#### 4-67. Radiator

##### a. General Maintenance and Inspection.

Maintenance of the radiator consists of keeping the exterior of the radiator core clean, the interior free from rust and scale, and the radiator free from leaks. Check the cooling system fluid level and for leaks each 100 operating hours. The exterior of the radiator core should be cleaned and the radiator inspected for leaks each 100 hours of normal service of the vehicle. Cleaning should be performed by blowing out with air stream or water stream directed from the rear of the radiator. Visual inspection is not sufficient as the accumulation of small particles of foreign material on core surfaces can restrict cooling without closing the core openings.

b. Radiator Leakage. Radiator leakage occasionally results from corrosion perforation of the metal but most leakage results from mechanical failure of soldered joints when too much strain has been put on the joint. Fractures occur most often at the joint where the radiator inlet and outlet pipes are attached to the tanks. When the seams break, the entire soldered joint is exposed and can corrode, but breakage rather than corrosion is the primary cause of seam leakage. Examine the radiator carefully for leaks before and after cleaning. Cleaning may uncover points of leakage already existing but plugged with rust. White, rusty, or colored leakage stains

indicate previous radiator leakage. These spots may not be damp if water only or methyl-alcohol-base anti-freeze is in the cooling system since such coolants evaporate readily. An ethylene-glycol-base antifreeze shows up existing leaks as it does not evaporate.

##### c. Radiator Flushing.

(1) It is recommended when using water for coolant that the cooling system be flushed and checked for leaks twice a year, preferably in the fall before antifreeze is added and in the spring when the antifreeze is drained.

(2) Reverse flushing will aid greatly in removing rust and scale, especially when used with a flushing solution. A cleaning solution should be used to loosen the rust and scale before reverse flushing the cooling system.

(3) Flushing is accomplished through the system in a direction opposite to the normal coolant flow. This action causes the water to get behind the corrosion deposits and force them out. Continue this flushing operation until the water runs clear through the top hose.

d. Radiator Removal. Refer to figure 4-33 and proceed as follows:

(1) Remove the engine cooling fan from the fan hub on the water pump shaft.

(2) Drain the cooling system.

(3) Disconnect the upper and lower radiator hoses from the radiator.

(4) Disconnect the transmission oil cooler lines at the bottom radiator tank. Plug transmission oil cooler ports in the radiator immediately to prevent system contamination.

(5) Remove bolts (14), washers (17), nuts (15), rubber mounts (16), and remove radiator from the vehicle.

##### e. Testing Radiator for Leakage.

(1) With radiator removed from vehicle, install radiator cap and block or plug the upper and lower radiator hose connections.

(2) Remove the drain cock and connect an air line with an air pressure gage to the drain cock port.

(3) Submerge the radiator in a tank of water. Open the air line to the radiator and apply a pressure of not more than 12 to 15 PSI.

(4) Watch the radiator for signs of bubbles coming from the core during this pressure test. The pressure cap should open at 12 to 15 PSI. Shut off the air to the radiator and allow the air to escape until the safety cap seats. Hold the pressure for 5 minutes. If no bubbles appear from the core, the radiator is good. If bubbles appear, mark the origins of the bubbles and remove the

radiator from the tank, Refer a leaking radiator to direct or general support maintenance for repair.

*f. Radiator Installation.* Refer to figure 4-33 while installing radiator according to the following procedures:

(1) Install the radiator in position and secure radiator (21) and mounts (16) by installing bolts (14), washers (17) and nuts (15).

(2) Connect the transmission oil cooler lines to the ports at the bottom of the radiator.

(3) Connect the upper and lower radiator hoses (2) and (11) to the radiator inlet and outlet.

(4) Install drain cock (12) and make certain it is closed.

(5) Refill cooling system with the proper coolant solution. Complete refill requires 16 quarts. Start the engine and allow coolant to circulate to purge trapped air. Recheck coolant level and add coolant as required.

(6) Install radiator pressure cap and check for leakage. Check transmission fluid level, and add fluid as required.

### Section XIII. MAINTENANCE OF ENGINE

#### 4-68. General

The engine is a six cylinder, four cycle, overhead valve industrial engine which runs on regular grade fuel. Engine displacement is 300 cubic inches. The engine is equipped with a 12 volt electrical system including coil and distributor type ignition. The engine features a single throat downdraft carburetor with manual choke, velocity governor, and a mechanical fuel pump.

#### 4-69. Lubrication and General Maintenance

Lubrication services are covered in paragraph 3-3. Maintenance procedures applicable to the fuel system, electrical system, cooling system and exhaust system are covered in their respective sections.

#### 4-70. Cylinder Head and Valves Inspection

*a.* Every 1000 hours of operation, check cylinder head bolts for proper torque, and tighten as required. See paragraph 4-72 for cylinder head bolts torque sequence.

*b.* Check valve clearance and adjust as required. See paragraph 4-71 for procedure.

*c.* Check closely for leakage at manifold and cylinder block-to-cylinder head mating surfaces. Leakage indicates a defective gasket or a crack or other defect in the cylinder head or block.

#### 4-71. Valve Clearance Adjustment

Paragraph 4-71, and Figures 4-36 and 4-37 have been rescinded.

#### 4-72. Cylinder Head Removal and Replacement

Paragraph 4-72 and Figure 4-38 have been rescinded.

(Page 4-56 has been rescinded.)



#### 4-73. Manifolds

The manifolds are essentially two separate networks of pipes used to conduct gases to and from the engine. The inlet manifold carries the fuel-air mixture from the carburetor to each of the six cylinders. The carburetor and governor are mounted directly to the inlet manifold. The exhaust manifold carries the engine exhaust from each cylinder to the exhaust system. The connecting flange for the exhaust pipe is made into the exhaust manifold.

##### a. Inspection.

(1) Check the manifold gasket surfaces for defective gaskets and evidence of leakage.

(2) Check for cracks or defects in castings in either manifold.

(3) Replace gaskets of manifolds if any defects are found.

##### b. Removal.

(1) Refer to figure 4-39 and remove wing nut, plate, and the air cleaner inlet elbow. Disconnect the choke cable at the carburetor. Disconnect the accelerator cable at the carburetor. Remove the accelerator retracting spring.

(2) Disconnect the fuel inlet line and the distributor vacuum line from the carburetor.

(3) Disconnect the exhaust pipe from the exhaust manifold.

(4) Disconnect the power brake vacuum line.

(5) Remove the bolts and nuts attaching the manifolds to the cylinder head (fig. 4-40). Lift the manifold assemblies from the engine. Remove and discard the gaskets.

(6) To separate the manifolds, remove the nuts joining the intake and exhaust manifolds.

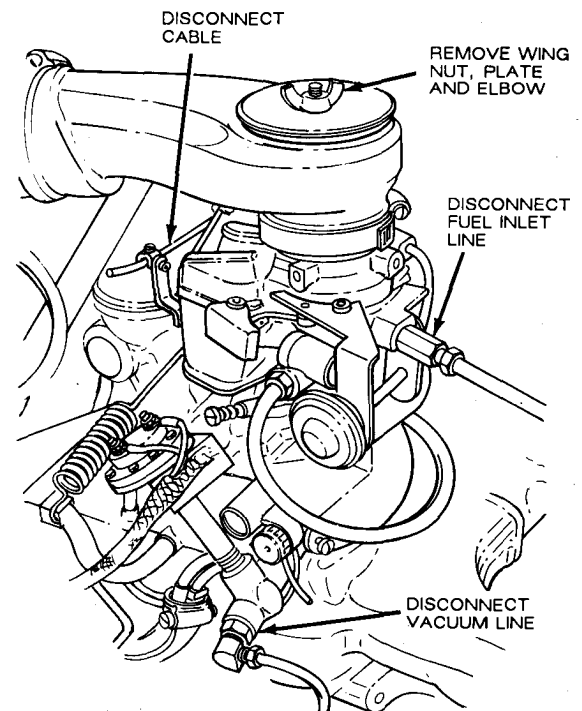

TA501874

Figure 4-39. Manifolds Removal

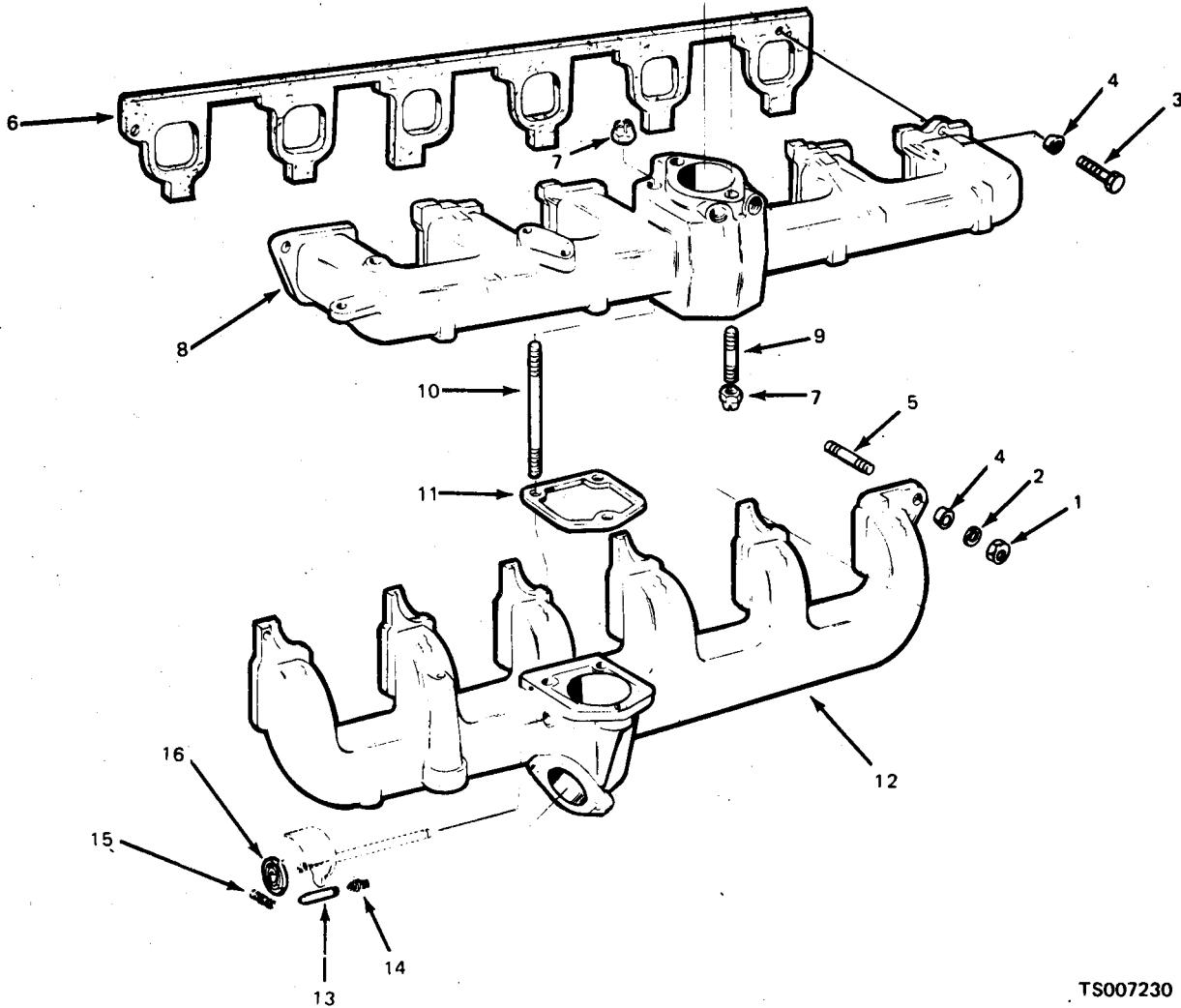

TS007230

- |             |                    |                      |            |
|-------------|--------------------|----------------------|------------|
| 1. Nut      | 5. Stud            | 9. Stud              | 13. Pin    |
| 2. Washer   | 6. Gasket          | 10. Stud             | 14. Spring |
| 3. Capscrew | 7. Nut             | 11. Gasket           | 15. Spring |
| 4. Clamp    | 8. Intake manifold | 12. Exhaust manifold | 16. Spring |

Figure 4-40. Manifolds Installation

*c. Installation.*

(1) Clean the mating surfaces of the cylinder head and manifolds,

(2) If one of the manifolds is to be replaced, remove the tube fittings from the discarded manifolds and install them in the new manifold as required. Also install new studs in the new manifold,

(3) If the intake and exhaust manifolds have been separated, coat the mating surfaces lightly with graphite grease and place the exhaust manifold over the studs on the intake manifold. Install the lockwashers and nuts. Tighten them finger tight.

(4) Install a new intake manifold gasket.

(5) Coat the mating surfaces lightly with graphite grease. Place the manifold assemblies in position against the cylinder head. **MAKE SURE THAT THE GASKETS HAVE NOT BECOME DISLODGED. INSTALL THE ATTACHING WASHERS, BOLTS AND NUTS.** Torque the bolts and nuts to specifications in the sequence shown in figure 4-41. Torque exhaust manifold to cylinder head bolts to 23-28 ft/lbs. Torque intake to exhaust manifold bolts and nuts to 28-33 ft/lbs.

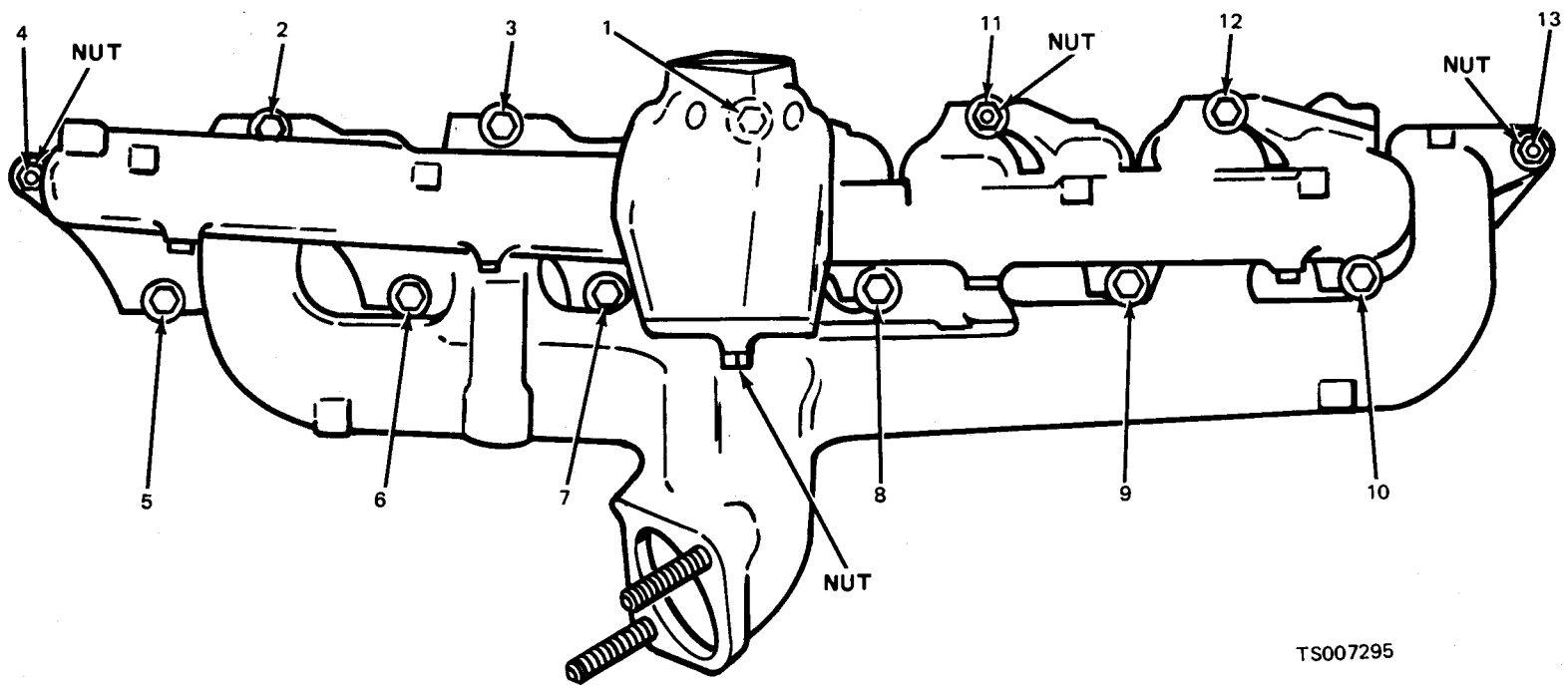

TS007295

Figure 4-41. Manifold Bolts Torque Sequence

#### 4-74. Wheels

*a. General.* Wheels are of the steel disc type, the rear wheels being the two-piece locking type, while the front wheels are the split two-piece wheel to permit mounting of the smaller tire.

*b. Removal.*

(1) When removing rear tire and wheel assemblies, it is only necessary to raise the rear wheels off the ground by means of a jack or hoist, and remove the wheel mounting nuts.

(2) When removing front wheels, make certain that all air pressure is relieved, then

proceed to remove the wheels by removing **ONLY** the inner set of nuts as shown in figure 4-42. Do not disturb the nuts on the larger bolt circle (nearer the rim).

**WARNING**

**Never remove front wheels and tires without first completely deflating the tire. Remove the valve core to make certain that all pressure is exhausted. Deflating prior to removal is recommended for rear tires also.**

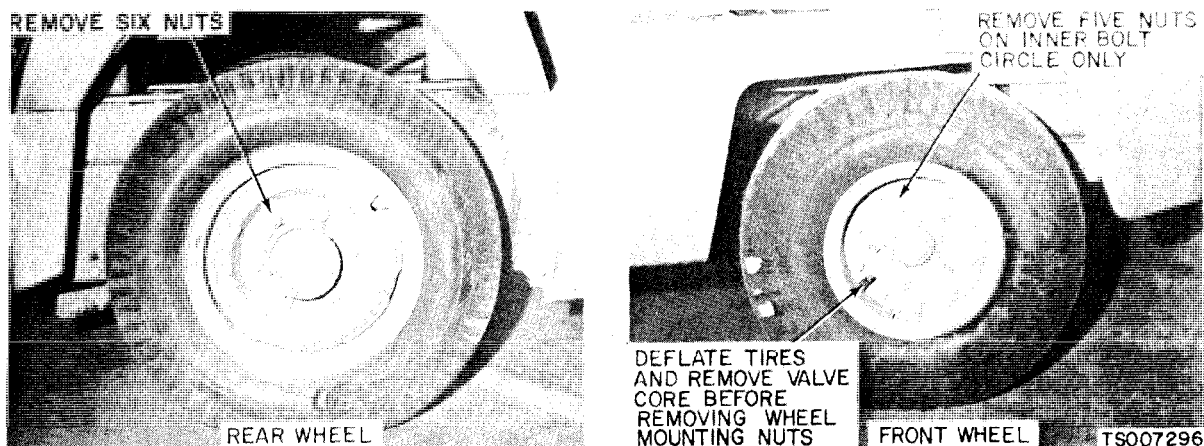

Figure 4-42. Wheel Removal

(3) When mounting tire and wheel assemblies to the vehicle, torque rear wheel mounting nuts to 125-140 ft/lbs, and torque front wheel mounting nuts to 60-75 ft/lbs.

#### 4-75. Wheel Bearings

*a. General.* Tapered roller wheel bearings are used on both front and rear wheels. Bearing preload adjustment is maintained at the rear axle by means of two locknuts and a tabbed lock-washer; and on the front wheels by means of a single castellated nut and cotter pin.

*b. Lubrication.* Every 1000 hours, remove wheels, grease caps, rear axle shafts and brake drums to expose wheel bearings refer to figure 4-43. Thoroughly clean out bearings and recesses in brake drums to remove all traces of old grease. Bearing cones may be rinsed in Solvent, Federal Specification P-D-680, and allowed to air dry. Do not spin bearings dry with compressed air. Repack bearing cones and hub recesses with the proper grease as specified in the Lubrication Order LO 10-3930-633-12.



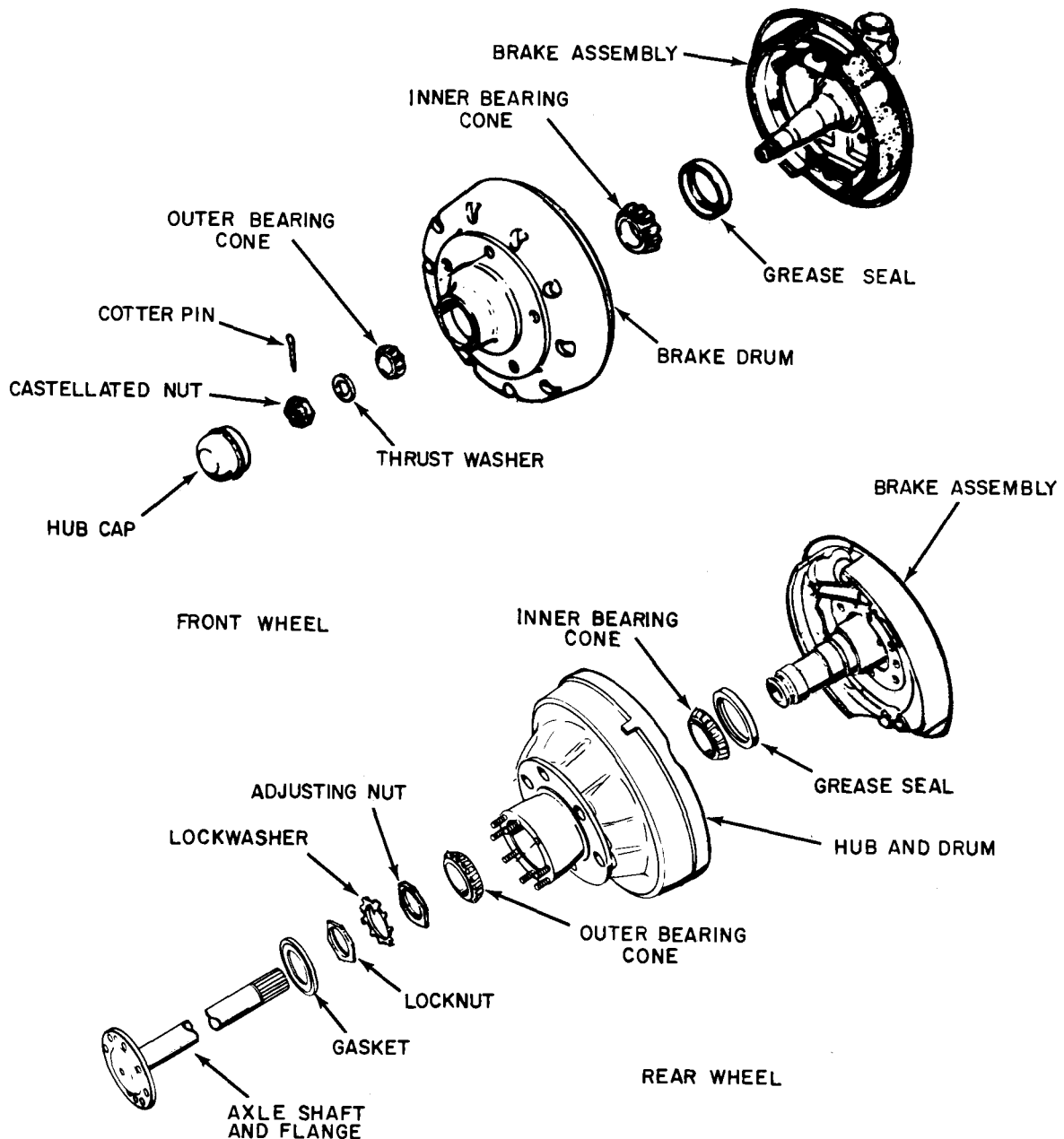

TS007297

Figure 4-43. Wheel Bearings and Seals

*c. Front Wheel Bearing Adjustment.*

(1) Raise front of machine so that the tires clear the ground.

**WARNING**

After raising machine and before making any adjustments or adjustment checks, place adequate (heavy) blocking (sufficient to support the weight of the machine ) under the frame to prevent accidental lowering or falling of the vehicle, thus preventing personal injury to mechanic or bystanders.

(2) Inspect adjustment of bearings by gripping top and bottom of tire, chuck tire in and out to determine looseness or wobble. Now grip front and rear side of tire; chuck tire in and out to determine looseness or wobble.

**NOTE**

Before making wheel bearing adjustment, be sure play (looseness or wobble) is in the wheel bearings and not in the king pins. If wheel bearings need adjusting, clean and repack bearings before making adjustments. Refer to lubrication paragraph.

(3) If looseness or wobble is in the wheel bearings, remove hub cap and spindle cotter pin. See figure 4-44. Tighten nut with a 12-inch wrench and at the same time rotate the wheel in one direction and then in the other until there is a slight bind to be sure all bearing surfaces are in contact. Then back off the nut 1/16 to 1/4 turn allowing the wheel to rotate freely. Secure nut at this position with a new cotter pin and replace hub cap.

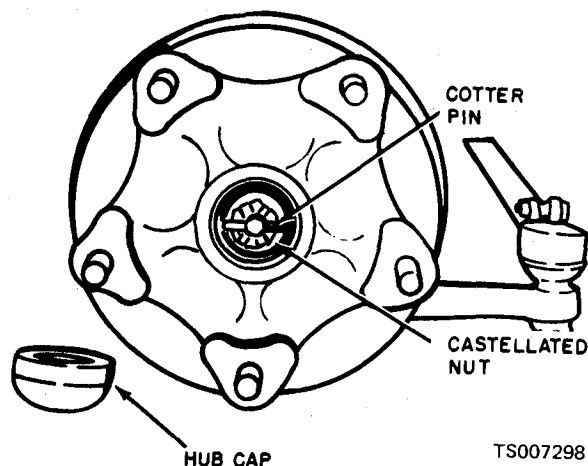

Figure 4-44. Front Wheel Bearings Adjustment

*d. Rear Wheel Bearings Adjustment.*

(1) Refer to figure 4-45. Wheel and tire, though not shown in the illustration, should be left on the axle.

(2) Using the jack screw holes in the axle shaft flange, remove axle shaft after all six nuts are removed from mounting studs.

(3) Bend up the tangs on the lockwasher and remove the outer locknut and the tabbed lockwasher as shown in figure 4-45.

(4) Apply a large socket wrench to the inner tube nut and tighten until drag is felt when turning the hub. (Be sure brake shoes are not causing drag). Back off the nut slightly until the hub turns free and install nut lock, outer tube nut and tighten. Clinch nut lock to retain nuts in this position.

(5) Coat the axle shaft flange to hub mating surface with No. 2 Permatex.

(6) Insert axle shaft in tube and rotate slowly until splines on shaft are in registry with the differential side gears. Push shaft in and install the retaining nuts and tighten to 52-57 ft/lbs torque.

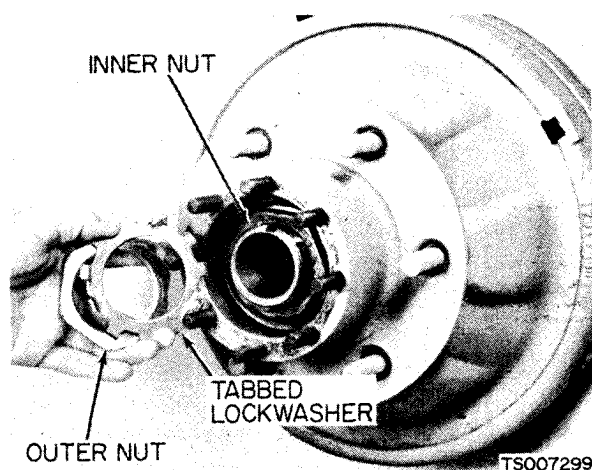

Figure 4-45. Rear Wheel Bearings Adjustment

## Section XV. MAINTENANCE OF BRAKE SYSTEM

### 4-76. General

The four wheel hydraulic brakes are of the internal expanding shoe type. The brake system incorporates a tandem master cylinder where the front axle brakes and the rear axle brakes are on separate hydraulic circuits. This arrangement prevents complete loss of braking action in cases of failure at some point in the system. The operator's pedal effort is assisted by a vacuum booster on the master cylinder push rod. Engine vacuum is used to operate the booster. Each brake assembly provides a means for mechanical adjustment of lining-to-drum clearance.

### 4-77. Inspection

*a. Master Cylinder Fluid Level Check.*

(1) Check the brake fluid level in the master cylinder. The brake fluid should be within 1/4 inch of the top. Fill with VV-B-680 Heavy Duty Hydraulic Brake Fluid.

(2) Check the master cylinder filler cap vent hole for obstructions. Vent must be open at all times. Clean if necessary.

*b. Brake Pedal Free Travel Check.* A correctly adjusted brake pedal is important so that the internal ports in the master cylinder are not blocked by the cylinder piston. An improperly adjusted pedal will block the internal ports so that upon releasing the brake pedal, fluid will be trapped in the lines and hold the brake linings in contact with the brake drums. This will cause

lining wear and excessive fuel consumption. Using a ruler, measure brake pedal free travel. (Depress pedal by hand.) Clearance should be measured from top pedal position to where the pedal meets resistance from the master cylinder. When pedal meets resistance from the master cylinder, the distance traveled should be  $\frac{1}{2}$  to  $\frac{3}{4}$  of an inch. If the free travel is incorrect, adjust as follows:

- (1) Locate the pedal to push rod connecting link, shown in figure 4-46.
- (2) Remove cotter pin and clevis pin from one end of this connecting link.

- (3) Loosen locknut.
- (4) Rotate clevis to obtain specified pedal free travel.
- (5) Tighten locknut to hold adjustment.
- (6) Reinstall clevis pin and cotter pin.
- (7) If the brake pedal travels beyond the free travel distance, this could indicate either of the following conditions:
  - (a) Lack of fluid in the reservoir.
  - (b) Air in the brake system lines.
  - (c) Brake linings need adjustment or replacement.

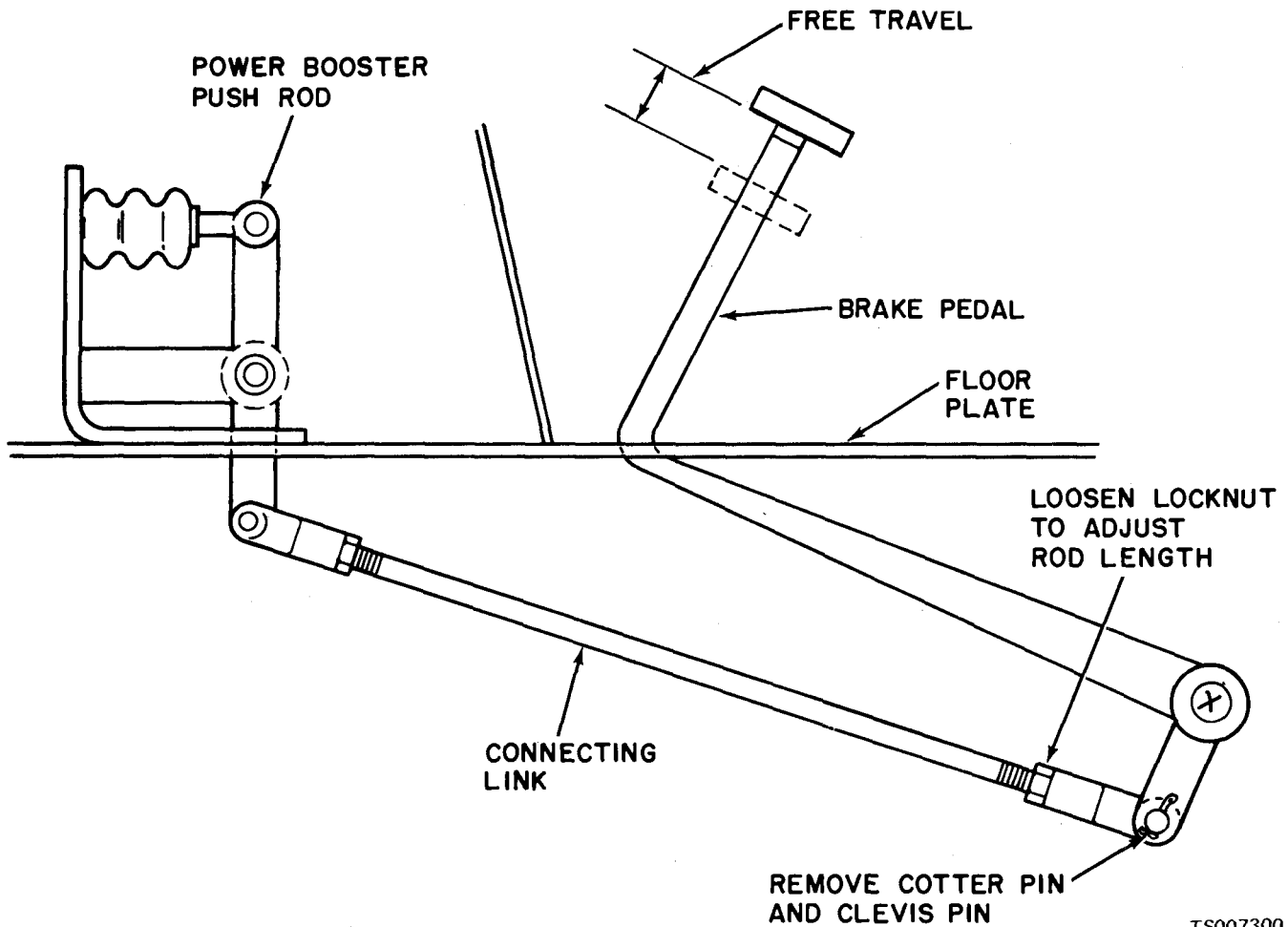

TS007300

Figure 4-46. Adjusting Pedal Free Travel

c. *Power Brake System Test.* As a system check, apply brakes several times with the engine off and car standing still. Hold the brake pedal applied firmly and start the engine. The brake pedal should drop or "fall away" slightly under steady pressure but then should remain firm without further travel or sponginess.

- (1) If pedal fails to "fall away," check vacuum hose connection.
- (2) If pedal continues to fall, check and

tighten all hydraulic connections and bleed screws. Apply pedal again and if pedal again falls away to floor, there is a hydraulic leak in the system. Locate and repair leak.

- (3) If pedal is spongy, bleed remaining air out of hydraulic system.

d. *Fluid Leakage Check.* The general routing of all the brake system tubing is shown in figure 4-47. Check at each connector for loose fittings, cracks, or signs of leakage, and replace damaged

parts. During brake inspection, check wheel cylinders for signs of leakage. Final connections to front wheel cylinders are made by means of flexible hoses. Check these hoses for kinks, chafing, and any sign of wear or deterioration. Tighten loose fittings and replace parts to eliminate leakage. Always bleed the brakes after such a repair.

#### 4-78. Bleeding the Brake System

a. Proper operation of the hydraulic brake system requires a solid column of fluid without air bubbles at all points in the pressure system. Under certain conditions it becomes necessary to bleed fluid from the system in order to expel air bubbles which have become mixed with the fluid.

b. The necessity of bleeding is indicated by a soft, spongy pedal or at any time a brake line is removed (or broken).

(1) Raise all four wheels far enough to clear the floor and place heavy blocking under the machine frame so it cannot accidentally become lowered. Deflate the tires and remove the wheels from the hub assembly.

#### **WARNING**

**Deflate tires before removing front wheels from vehicle.**

(2) Check the brake pedal free travel (see paragraph 4-73). Clean dirt from around the filler cap of the master cylinder reservoir. Brake fluid should be within ¼-inch of the top. With filler cap off the master cylinder, depress and release brake pedal. A small displacement of fluid should be noticed in the cylinder reservoir. If this happens the brake pedal (upon being released) is returning the master cylinder piston to its normal position to open a master cylinder port. This port must be open. If fluid does not return to the reservoir (when releasing brake pedal), this indicates improper pedal free travel and a pedal adjustment is required.

(3) Be sure the master cylinder reservoir is filled, and keep it full during this procedure.

(4) Refer to figure 4-47 and bleed front and rear brake lines at their highest points first; "A" and "B" respectively. Loosen each one separately and bleed as follows: Depress break pedal slowly and *hold*, allowing fluid and air to escape. Tighten fitting, then release brake pedal. Repeat procedure until fluid is free of air bubbles.

(5) Install a bleeder hose on one of the wheel cylinder bleeder screws and submerge the unattached end of the hose in a clean transparent jar containing several inches of brake fluid.

#### NOTE

During bleeding of the wheel cylinders the jar should be elevated to a position higher than the bleeder screws making sure that the end of the hose remains submerged in the fluid at all times.

(6) Loosen bleeder screw and slowly push brake pedal to the floorboard. Hold pedal in this position until bleeder screw is retightened. Repeat this operation until all air bubbles disappear and clear fluid is being pumped into the jar.

(7) Install bleeder hose on the remaining bleeder screw and proceed as in step (5). After all bleeding has been completed, recheck fluid level in master cylinder. Fill to within ¼-inch of the top with SAE 70 R3 brake fluid, Specification VV-B-680. Replace cylinder cap.

(8) Replace wheels. Inflate tires. Remove blocking and lower machine to floor.

#### NOTE

Remember that the brake pedal should be depressed slowly and held to the floorboard until the line connections or bleeder screws are securely tightened. This prevents the possibility of air being drawn into the system during the bleeding operation. bleeding operation. Check master cylinder reservoir level periodically during manual bleeding and fill to within ¼-inch of the top as required.

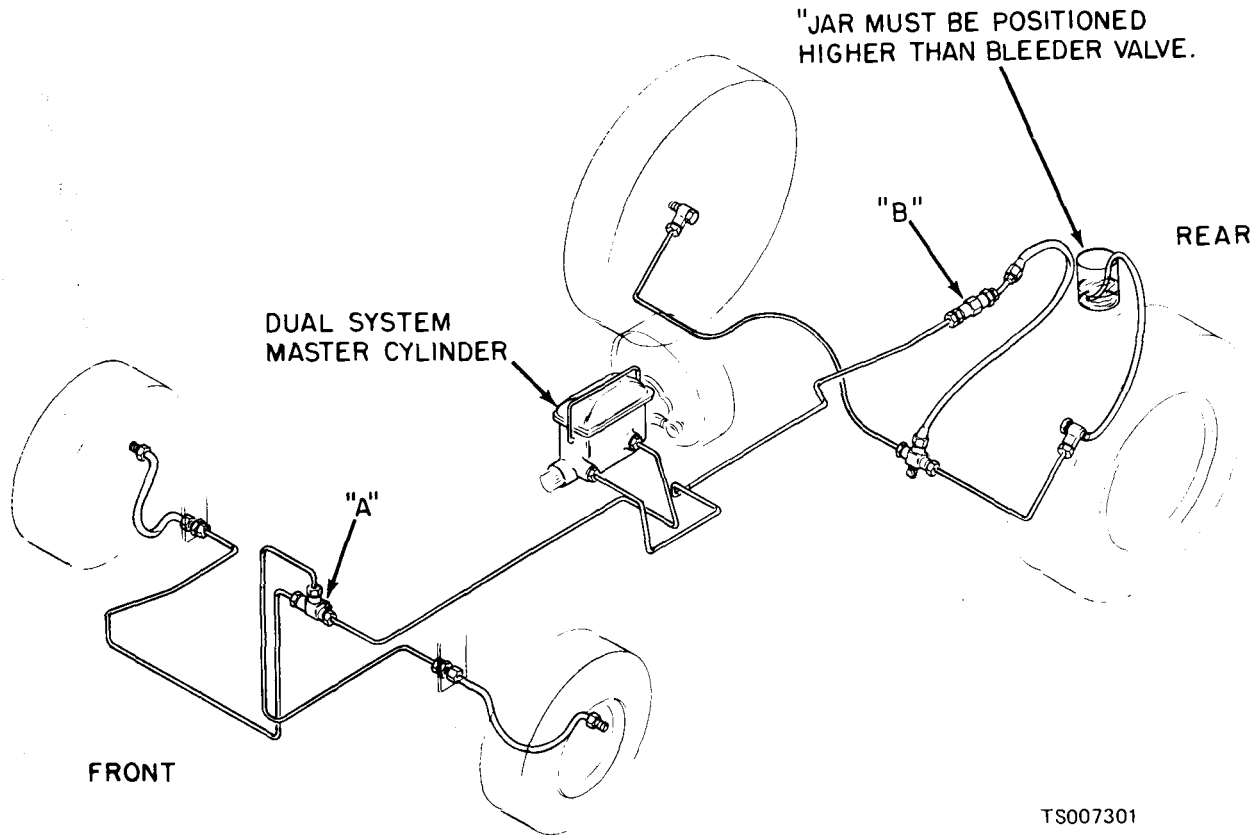

Figure 4-47. Brake System Bleeding

#### 4-79. Brake Adjustment

a. *Front Wheels.* When the brake drums are hot, allow to cool, then proceed as follows:

(1) Adjust brake pedal free play  $\frac{1}{2}$  to  $\frac{3}{4}$  of an inch.

(2) Raise tractor until steer wheel tires clear floor. Be sure tractor is properly supported and blocked.

#### WARNING

**After raising machine and before making any adjustments, adjustment checks or before performing any maintenance, place adequate blocking (sufficient to support the machine) under the frame to prevent accidental lowering or falling of the vehicle, thus preventing personal injury to mechanic or bystanders.**

(3) Bleed hydraulic system as required to remove entrapped air.

(4) At each wheel, adjust each brake shoe in turn, taking a forward acting shoe first.

(a) Rotate the shoe (toe) adjusting cam until the shoe drags. A forward acting shoe cam rotates forward; a reverse acting shoe cam rotates in reverse. See figure 4-48.

(b) Back off the shoe (toe) adjusting cam, while rotating the drum forward, until the shoe is just free of drag. Operate the pedal several times to center the shoes, then provide a running clearance by again backing off the cam  $\frac{1}{8}$  to  $\frac{1}{4}$  of a turn.

(5) Remove blocking, lower vehicle to the floor and test the brakes.

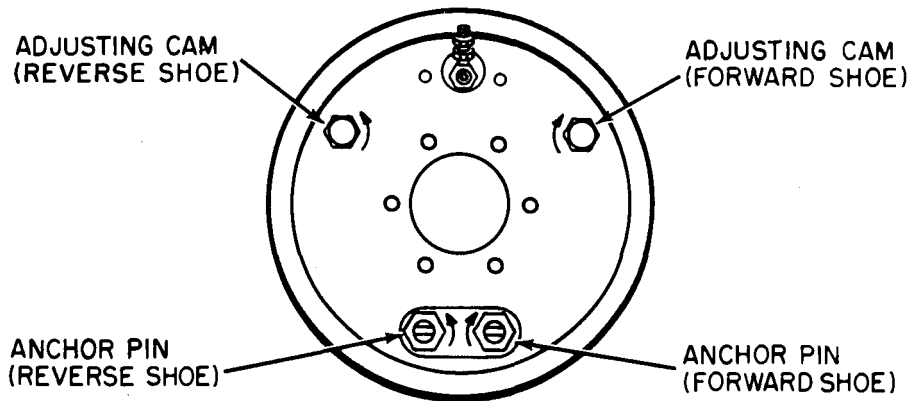

ADJUSTMENT IN DIRECTION SHOWN  
WILL DECREASE LINING CLEARANCE

TS007302

Figure 4-48. Adjustment Cams

*b. Rear Wheels.*

(1) To decrease clearance at anchor end of forward shoe, turn forward shoe anchor pin in direction illustrated by arrow.

(2) To increase clearance at anchor end of forward shoe, turn forward shoe anchor pin in opposite direction indicated by arrow.

(3) Alternate between the anchor pin and the adjusting cam until brake shoe feeler gage (.010 in.) just fits between the drum and lining at both "heel" and "toe." Then tighten the anchor pin locknut.

(4) Repeat this same procedure at the opposite shoe and on the other brake assembly.

**4-80. Master Cylinder**

*a. Removal.*

(1) Refer to figure 4-47 and disconnect the front and rear brakes hydraulic lines at the outlet fittings on the side of the master cylinder.

**CAUTION**

**Plug, tape or otherwise seal the exposed ports in the open end of the tube fittings to prevent contamination of the system.**

(2) Remove the nuts and lockwashers on the studs extending through the master cylinder mounting flange (figure 4-49).

(3) Remove the master cylinder from the power booster section.

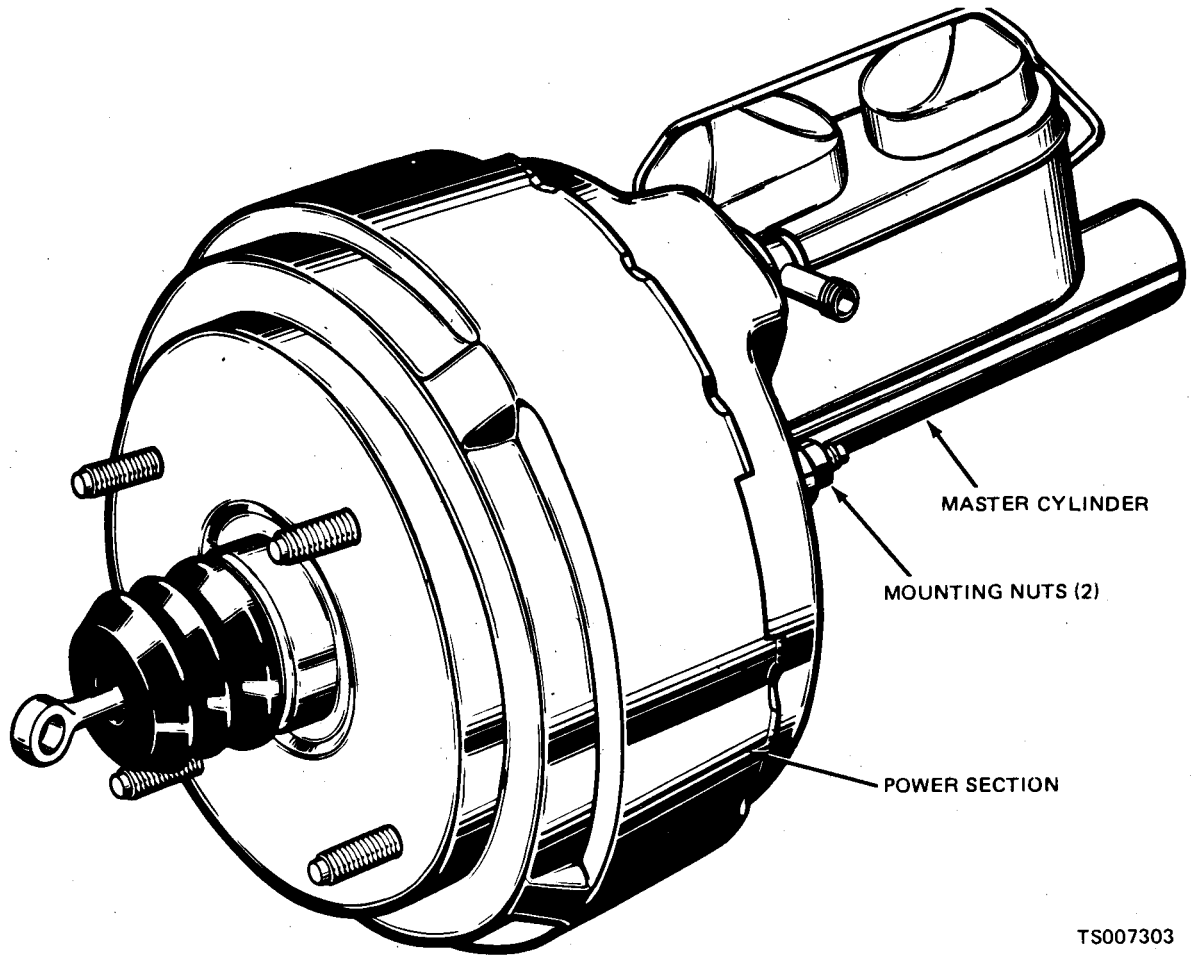

TS007303

Figure 4-49. Master Cylinder Installation

■ Page 4-68 is rescinded.







Page 4-69 is rescinded.

*b. Installation.*

(1) Install the master cylinder to the power booster diaphragm section so that the studs on the front of the diaphragm housing will extend through the holes on the master cylinder body casting flange.

(2) Secure the master cylinder to the power booster by installing nuts and lockwashers over power booster studs (see figure 4-48).

(3) Connect brake line tube fittings to the outlet ports on the side of the master cylinder casting.

(4) Bleed entire system as outlined in paragraph 4-78.

**4-81. Parking Brake**

The parking brake is mounted to the transmission output shaft flange and is controlled by the hand lever next to the operator's seat.

*a. Adjustment.* Refer to figure 4-52.

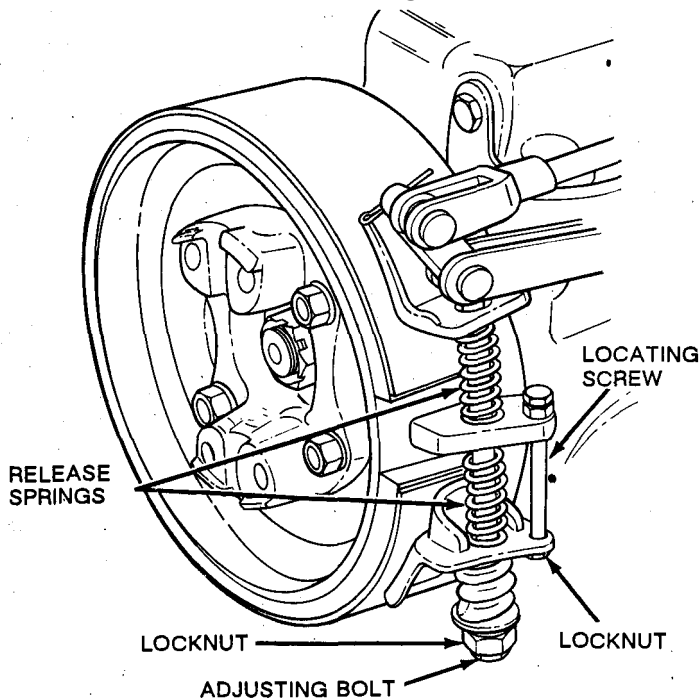

TA502239

Figure 4-52. Parking Brake Adjustments

(1) Set hand brake lever in fully released position and turn knob adjustment counterclockwise as far as possible.

(2) Turn brake band anchor clip bolt until feeler gage placed between lining and drum indicates a 0.010 to 0.025 inch clearance. See figure 4-53.

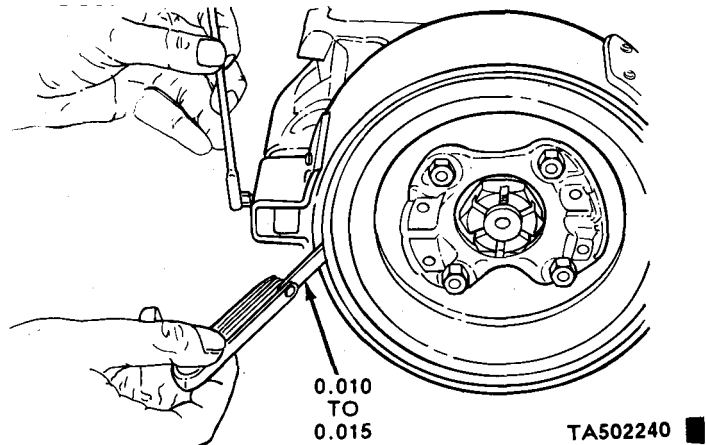

Figure 4-53. Band Centering Adjustment

(3) Loosen locknut and tighten screw until feeler gage placed between lower end of lining and brake drum indicates a 0.020 inch clearance. Tighten locknut when this clearance is obtained. See figure 4-54.

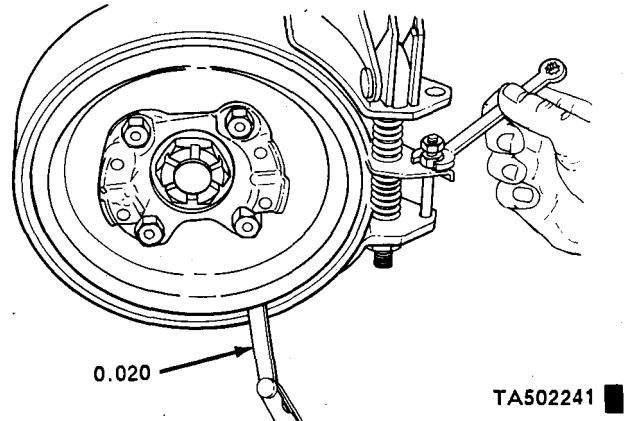

Figure 4-54. Lower Band Adjustment

(4) Loosen locknut from end of adjusting bolt until feeler gage placed between upper end of lining and brake drum indicates a 0.020 inch clearance. Tighten locknut when this clearance is obtained. See figure 4-55.

(5) Rotate adjusting knob, located at upper end of brake lever, clockwise until sufficient tension is obtained to properly apply parking brake when lever is actuated.

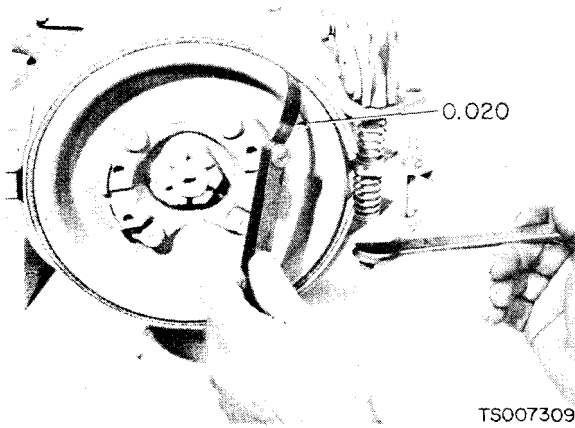
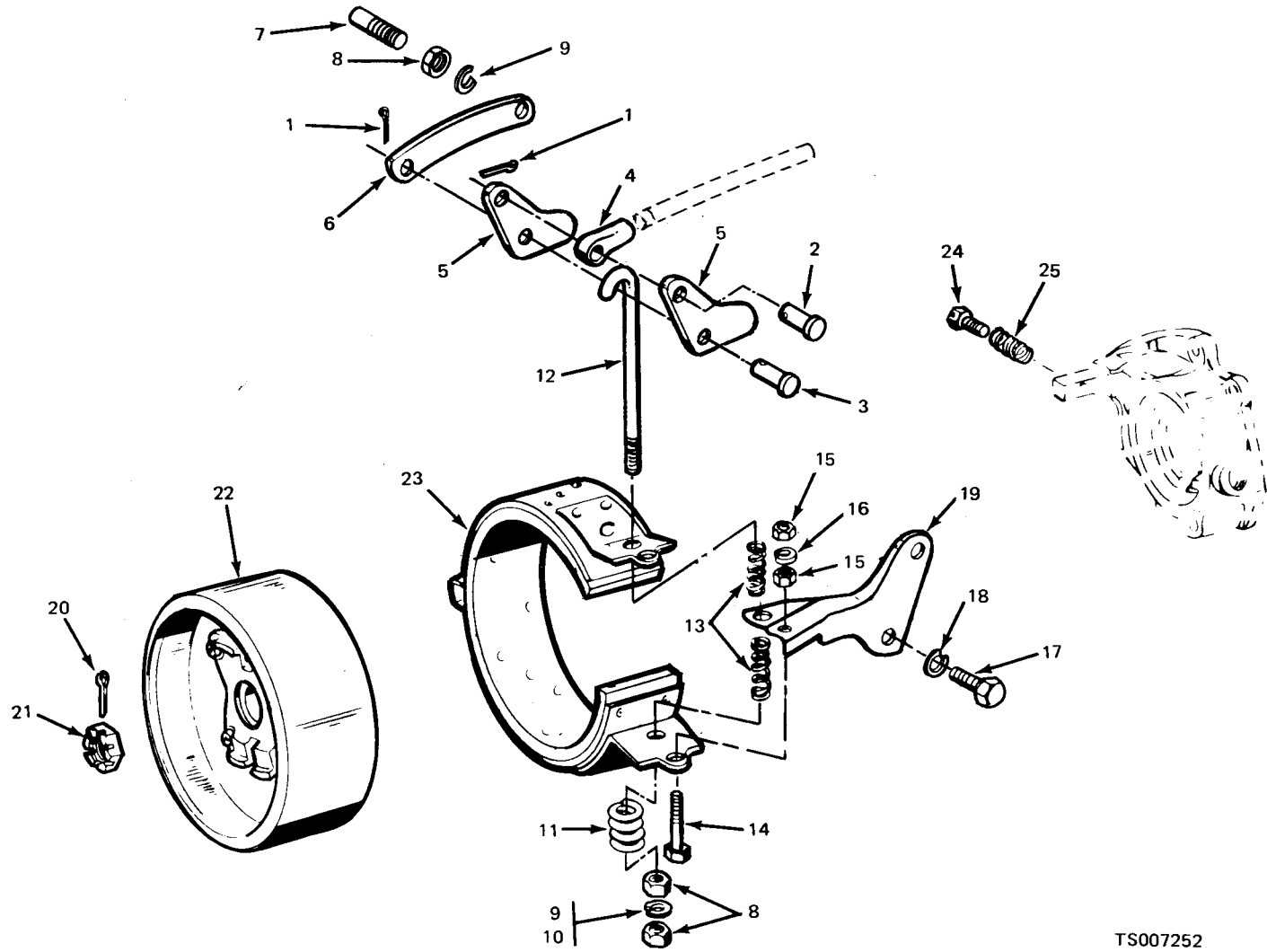

Figure 4-55. Upper Band Adjustment

*b. Removal.* Refer to figure 4-56.

(1) Shift the transmission into low gear and disconnect the drive shaft companion flange from the transmission output shaft flange by removing the four nuts.



- 1. Cotter pin
- 2. Clevis pin
- 3. Clevis pin
- 4. Rod end
- 5. Cam

- 6. Spacer link
- 7. Link stud
- 8. Nut
- 9. Lockwasher
- 10. Washer

- 11. Spring
- 12. Adjusting rod
- 13. Release springs
- 14. Screw
- 15. Nut

- 16. Washer
- 17. Screw
- 18. Lockwasher
- 19. Bracket
- 20. Cotter pin

- 21. Nut
- 22. Drum
- 23. Hand
- 24. Anchor bolt
- 25. Spring

Figure 4-56. Parking Brake Assembly

TS007252

(2) Apply the parking brake; remove the transmission output shaft flange attaching nut, then release the parking brake.

(3) Remove the cotter pin (1) and clevis pin (3), and disconnect the adjusting rod (12) from the cam.

(4) Remove the cotter pin and clevis pin (2), and remove the cam link (6) from the cam (5).

(5) Remove the lockwire and the anchor adjusting screw (24).

(6) Remove the brake band adjusting bolts (14) and nuts (15).

(7) Remove the brake bracket retaining capscrews (17).

(8) Lift the brake band (23) and lining assembly off the drum.

(9) Inspect the brake lining, and replace it if the distance between the brake lining surfaces and the top of the rivet is less than 1/32 inch.

*c. Installation.*

(1) Check the drum before reinstalling parking brake. If drum is rough, scored, or cracked, it must be replaced.

(2) Position the parking brake drum (22) and output shaft flange assembly to the transmission output shaft, and install the attaching nut (21).

(3) position the parking brake band assembly (23) over the drum, and install the bracket attaching screws.

(4) Install the brake band adjusting bolt (12) and nuts (8) and springs (13).

(5) Connect the cam link (6) to the lower end of the cam with clevis pin (3) and cotter pin (1).

(6) Connect the adjusting rod (12) to the upper end of the cam with clevis pin (2) and cotter pin (1).

(7) Adjust the parking brake, and install a lockwire in the anchor adjusting screw (24).

(8) Apply the parking brake, torque the transmission output shaft flange nut to specifications, then release the parking brake.

(9) With the transmission in low gear, connect the drive shaft at the flange and torque the four attaching nuts.

## Section XVI. MAINTENANCE OF REAR DRIVE AXLE AND SPRINGS

### 4-82. General

The rear axle is a single reduction, spiral bevel drive, with a reduction gearcase at the input shaft to provide a double reduction final drive ratio. The axle shafts are the semi-floating type. The axle is suspended beneath the frame by means of semi-elliptical leaf springs.

### 4-83. Inspection

At 500 hour intervals, inspect rear drive axle and drop gearcase as follows:

*a.* Check drop gearcase and differential housing gaskets for signs of leakage.

*b.* Operate tractor and listen for unusual noises from axle assembly. Operate through sharp right and left hand turns as well as straight ahead, when making this check.

*c.* Check springs and spring shackles for damage, loose hardware, lack of lubrication.

*d.* Check lubricant level in differential and drop gearcase and add oil as required (LO 10-3930-633-12).

### 4-84. Lubrication

Use only lubricants specified in LO 10-3930-633-12 when performing lubrication services as

outlined below. Refer to figure 4-57 and proceed as follows:

*a.* Drain differential by removing the lower capscrew on the front cover of the differential bowl. Drain differential at operating temperatures. Removal of the filler/plug will allow full atmospheric pressure to enter the differential bowl and speed up the draining process.

**NOTE**

Before removing plugs from either differential or drop gearcase, clean both assemblies so that the area around the drain, fill/level plugs is absolutely clean.

*b.* Remove drain plug from the drop gearcase and drain lubricant at operating temperature.

*c.* Replace drain plugs after both units are completely drained and tighten plugs securely.

*d.* Remove fill/level plug and fill differential with lubricant as recommended in LO 10-3930-633-12. Do not fill above the level of the plug hole. Replace plug and securely tighten.

*e.* Remove fill/level plug of drop gearcase and add one quart of lubricant. Then replace fill/level plug and securely tighten.

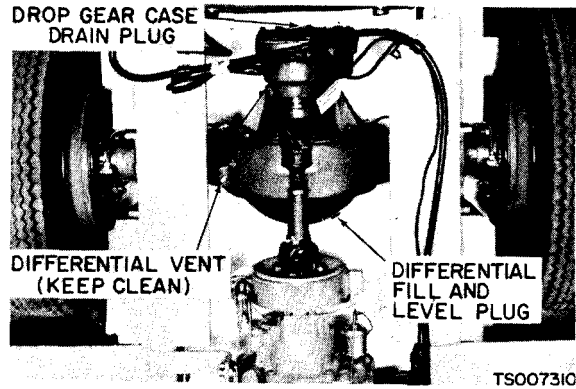

Figure 4-57. Differential and Drop Gearcase

## Section XVII. MAINTENANCE OF STEERING SYSTEM

### 4-85. General

The steering system consists of the steering wheel and column, the steering gear and pitman arm, the drag link, steering knuckles, and the tie rod. Refer to figure 4-58 for the layout of the steering system. Action of the steering gear (in response

to the turning of the steering wheel) is transmitted to the front axle steering knuckles through the pitman arm and drag link. The tie rod transmits the steering action from one steering knuckle to the other.

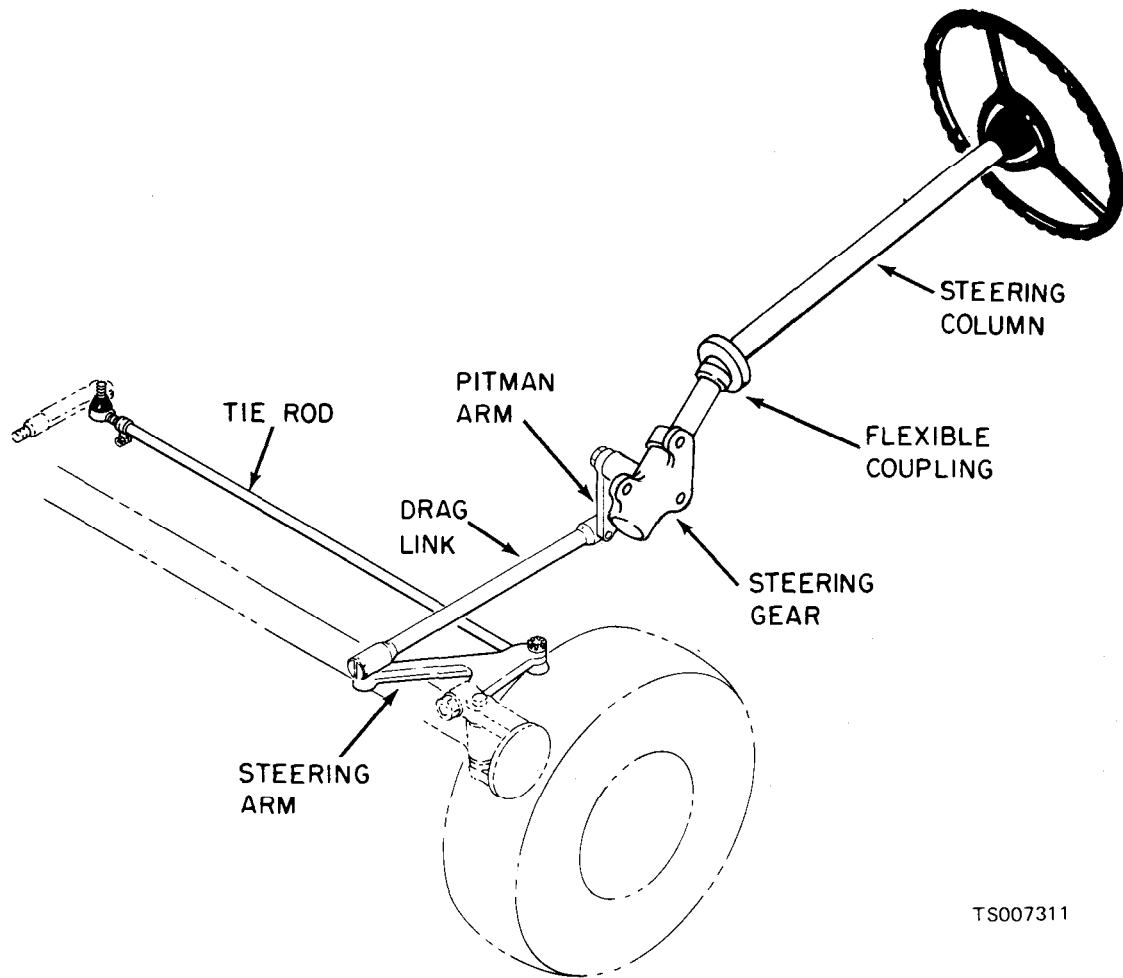

TS007311

Figure 4-58. Steering System

#### 4-86. Drag Link

*a. General.* The drag link connects the steering gear pitman arm with the steering knuckle on the left side of the front axle. The drag link consists of a rod having ball stud sockets at each end where it connects with the steering knuckle and pitman arm. Each ball socket is adjustable to compensate for wear, and includes a lubrication fitting. One of the sockets is threaded onto the rod to allow for a total or center-to-center length adjustment when adjusting steering linkage.

*b. Lubrication.* The drag link ball stud sockets must be lubricated at the fittings provided, every 100 hours, using GAA, Grease, Automotive and Artillery, MIL-G-10924 (LO 10-3930-633-12).

*c. Adjustment.* The desired adjustment for the steering linkage provides for the steering gear to

be in the exact center of its travel when front wheels are in the straight ahead position. Refer to paragraph 4-87 for a procedure on adjustment and centering of steering gear. Refer to figure 4-59, and remove cotter pins and loosen plugs in the pitman arm end of the drag link. Now center the steering gear so that pitman arm is in the center of its travel, and position front wheels in the straight ahead position. Loosen the nut and thread adjustable socket in or out on the drag link as required to align with pitman arm ball stud. Lock adjustable socket in this position by tightening nut, and install cup and plug. Tighten plug just so that all play is removed, and back off the plug just enough to allow the cotter pin to be inserted through the socket end and one of the slots in the nut. Lubricate ball socket.

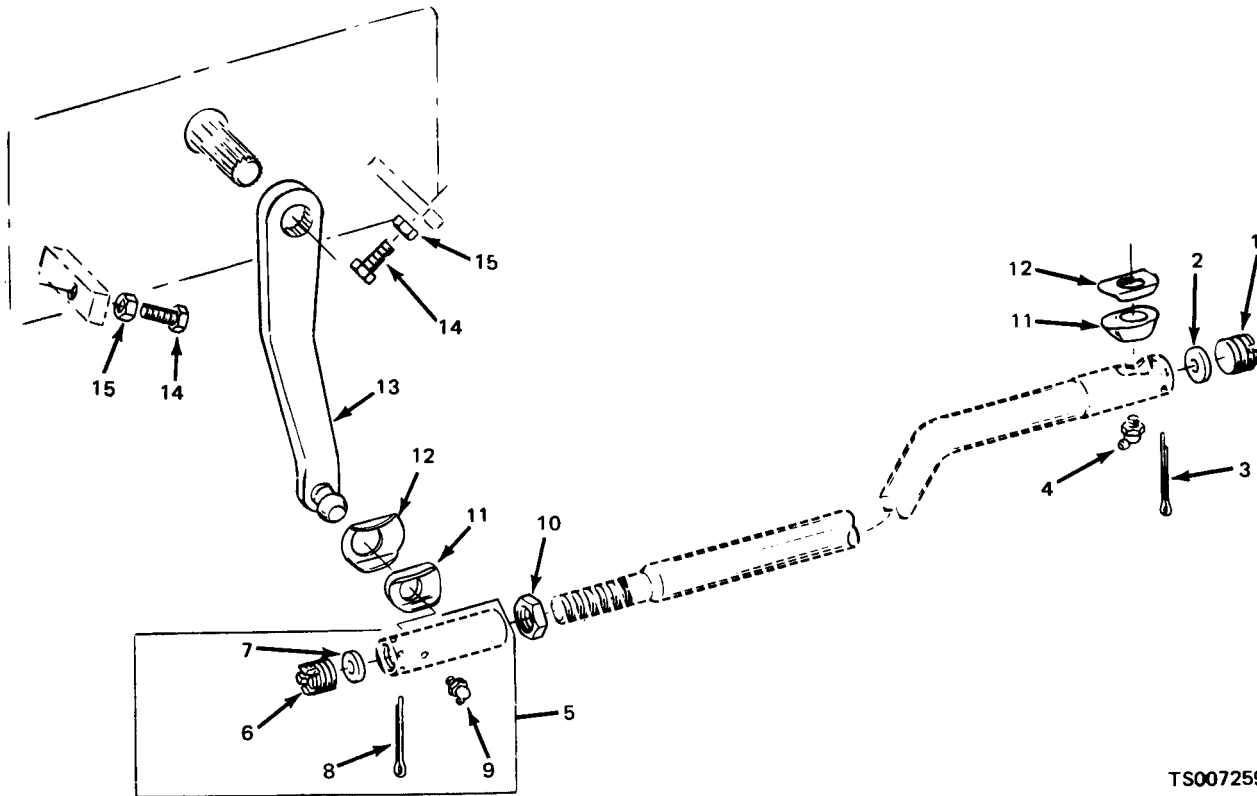

TS007259

- |                        |                        |                |
|------------------------|------------------------|----------------|
| 1. Adjusting plug      | 6. Adjusting plug      | 11. Seal       |
| 2. cup                 | 7. cup                 | 12. Shield     |
| 3. Coffter pin         | 8. Coffter pin         | 13. Pitman arm |
| 4. Lubrication fitting | 9. Lubrication fitting | 14. Stop screw |
| 5. Socket assembly     | 10. Nut                | 15. Locknut    |

Figure 4-59. Drag Link

*d. Repair and Replacement.*

(1) Repair of the drag link consists of replacement of any part see figure 4-59 found defective after removal and disassembly.

(2) To remove the drag link, remove cotter pin from each socket end, and loosen plugs until enough clearance is obtained to pull the sockets free of the ball studs.

(3) Further disassembly is accomplished as indicated by the exploded view illustration.

(4) Adjust drag link overall length as outlined in the preceding paragraph before installing. Make certain both ball sockets are properly lubricated. See LO 10-3930-633-12.

**4-87. Steering Gear Adjustment**

Steering gear adjustments must be made ONLY as outlined in the following steps. Refer to figures 4-60 and 4-61. Always check worm bearing thrust adjustment, and adjust if necessary, before making sector gear lash adjustment.

*a. Before making above adjustments, the following preliminary operations are necessary.*

(1) Disconnect steering drag link from pitman arm. Note relative position of drag link parts when disconnecting link so the parts may be re-assembled correctly.

(2) Check lubricant level. in steering gear housing. If low, add enough lubricant to bring level up to filler plug hole. See LO 10-3930-633-12.

(3) Tighten steering gear housing to frame side member bolts. See figure 4-60.

(4) Determine straight-ahead position of steering mechanism by turning steering wheel to extreme right. Then turn to extreme left, counting the exact number of turns from right to left end. Turn wheel back one-half number of wheel turns. Mark wheel with respect to steering column so center position may readily be found during adjustment procedures.



**CAUTION**

Approach extreme ends cautiously; worm ball nut must not strike ends with any degree of force.

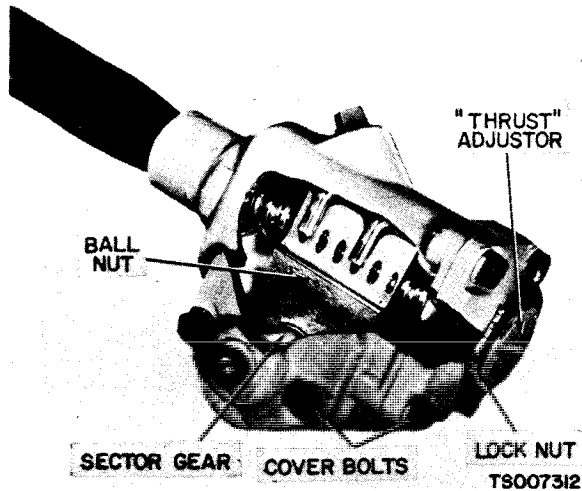

Figure 4-60. Steering Gear Thrust Adjustment

*b. Steering Gear Thrust Adjustment.*

(1) Check tightness of cover bolts see figure 4-60. Loosen locknut and turn lash adjuster screw see figure 4-61 counterclockwise a few turns to provide clearance between sector gear and worm ball nut.

(2) Turn steering wheel GENTLY to one extreme end. Turn wheel back one full turn. With spring scale on spoke of wheel, measure pull required to KEEP WHEEL MOVING. Pull on scale should be made at right angles to wheel spoke. If pull is within 1½ to 2 pounds, proceed to lash adjustment in the following paragraphs. If pull is not within 1½ to 2 pounds, adjust worm bearings. The pitman shaft adjustment must be made if worm bearing check is accomplished, or if the worm bearings are adjusted.

(3) If it is necessary to adjust the worm

bearings, loosen locknut and then turn worm bearing adjuster nut clockwise until all end play is removed see figure 4-60. Using spring scale, as directed in step (2), check pull and readjust as necessary; then tighten locknut securely.

*c. Sector Gear Lash Adjustment.*

(1) Steering gear mechanism must be in straight ahead position as previously explained.

(2) Turn lash adjuster screw clockwise to remove all lash between gear teeth. Tighten adjuster screw locknut. Position spring scale on steering wheel so pull may be made at right angles to wheel spoke.

(3) Measure pull while wheel is TURNED THROUGH CENTER POSITION. Readjust if reading is not within 2½ to 3 pounds.

(4) Tighten adjuster screw locknut, check pull again.

(5) After adjustments are made, install drag link on pitman arm.

**NOTE**

If steering linkage adjustment is necessary, do not install drag link to pitman arm. Refer to paragraph 4-86.c.

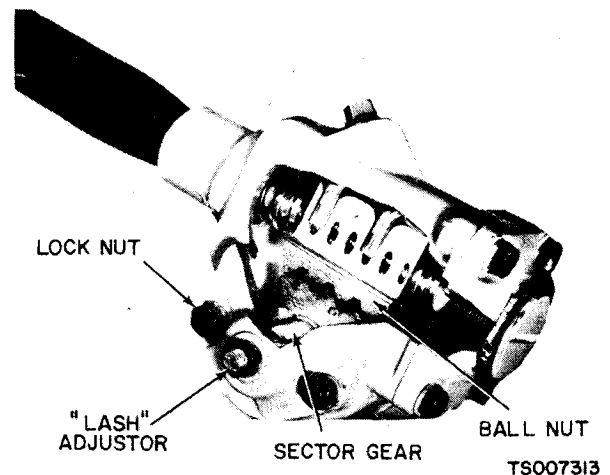

Figure 4-61. Steering Gear Lash Adjustment

## Section XVIII. MAINTENANCE OF FRONT AXLE AND SPRINGS

### 4-88. General

The front axle is a light truck type, being a solid I-beam with front wheel steering spindles attached directly at each end. The axle is suspended below the frame by means of semi-elliptical leaf springs. The steering spindles are attached by means of king pins through the knuckle and axle. A thrust bearing is used between the lower face of the axle and the steering knuckle to reduce friction (see figure 4-62).

### 4-89. Inspection

a. Check for bent front axle, loose or damaged U-bolts at spring pads.

b. Check springs for broken leaves, loose or damaged spring shackles.

c. Check front wheel bearings for proper adjustment (paragraph 4-75).

d. Check steering linkage parts for physical damage and secure attachment.

e. Refer damaged parts to direct or general support maintenance.

**4-90. Lubrication**

a. Clean all lubrication fittings prior to lubrication.

b. Lubricate all grease fittings with GAA, Grease, Automotive and Artillery, MIL-G-10924. A fitting is provided in each tie rod end, and at the upper and lower king pin bushings on each steering knuckle.

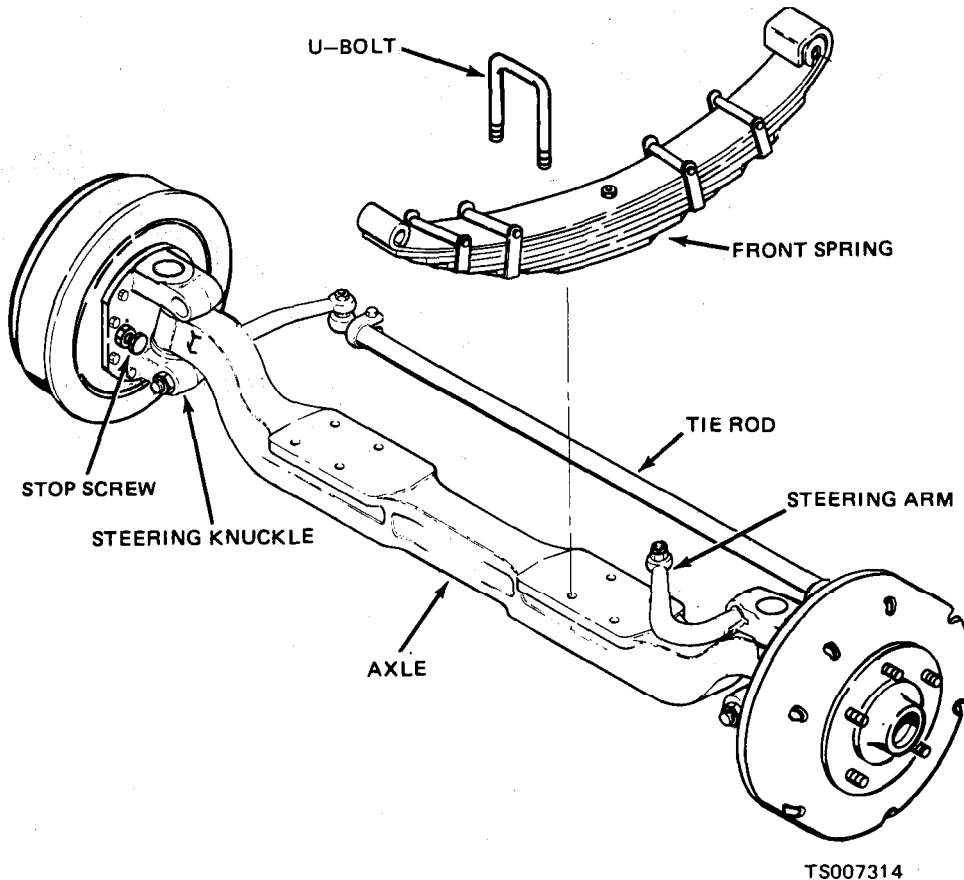

Figure 4-62. Front Axle

**4-91. Steering Stop Screw Adjustment**

The two stop screws, located on the front axle, are for adjusting the turning radius of the tractor. Adjustment is made by loosening the locknuts and turning the stop screws IN to lengthen

turning radius, or OUT to shorten turning radius. The proper turning radius is 109 inches, and can be obtained by setting stop screws so that each front wheel forms an angle of 330 with the front axle beam when toed out, and 530 when toed in.

**Section XIX. MAINTENANCE OF PINTLE HOOK**

**4-92. General**

The rear bumper plate of the tractor is equipped with a semi-automatic pintle hook type coupler. See figure 4-63 for installation details. The coupler will automatically connect with towing eyes at the proper height. Disengagement of the coupler is accomplished by means of the manual actuating lever.

**4-93. Inspection**

a. Refer to figure 4-63. Check latching mechanism for proper operation. Make sure coupler operates freely with no evidence of sticking or binding.

b. Check coupler mounting to make certain all mounting bolts are secure and in good condition. Check coupler height and adjust if required.

c. Check manual release handle for secure attachment and operation to release coupler without interference with rear deck cover or bumper plate.

#### 4-94. Replacement

a. Refer to figure 4-63. Remove mounting bolts, nuts and washers, and remove coupler.

b. Position new coupler over mounting slots and install mounting bolts, nuts and washers.

c. Adjust coupler height to a nominal 12 inches above ground level, and tighten mounting bolts securely.

d. Check coupler for proper operation.

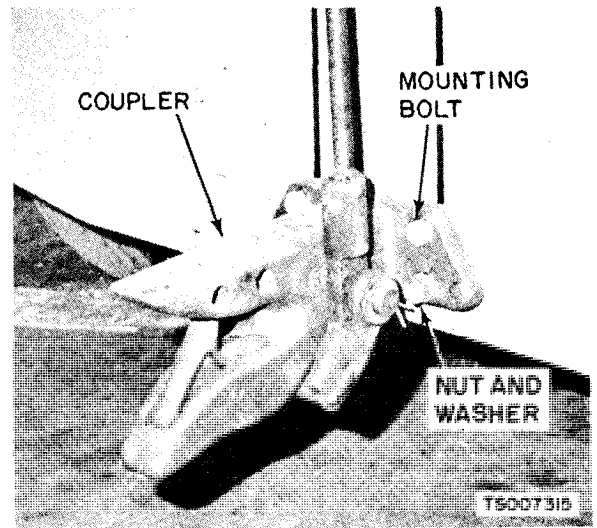

Figure 4-63. Pintle Hook Coupler



## APPENDIX A

### REFERENCES

---

A-1. Fire Protection		
	TB 5-4200-200-100	Hand Portable Fire Extinguishers Approved for Army Users
A-2. Lubrication		
	C91001L	Fuels, Lubricants, Oils and Waxes
	LO 10-3930-633-12	Lubrication Order for Tractor, Wheeled, Warehouse, Gasoline, 4-Wheel, Pneumatic Tired, 4,000 LB DBP, Clark Model 2330237, Army Model MHE-228
A-3. Painting		
	TM 43-0139	Painting Instructions for Field Use
A-4. Radio Suppression		
	FM 11-65	Radio Interference Suppression
A-5. Maintenance		
	TB ORD 651	Use of Antifreeze Solutions and Cleaning Compounds in Engine Cooling Systems
	DA PAM 738-750	The Army Maintenance Management System (TAMMS)
	TM 10-3930-633-34	Direct Support and General Support Maintenance Manual for Tractor, Wheeled, Warehouse, Army Model MHE-228, Clark "Model CTE-40-2330237
	DMWR 10-3930-633	Depot Maintenance Work Requirement for Tractor, Wheeled, Warehouse, Gasoline, 4-Wheel, Pneumatic Tired, 4,000 LB DBP, Clark Model 2330237, Army Model MHE-228
	TM 10-3930-633-20P	Organizational Maintenance Repair Parts and Special Tools List for Tractor, Wheeled, Warehouse, Gasoline, 4-Wheel, Pneumatic Tired, 4,000 LB Drawbar Pull (Clark Equipment Co., Model 2330237), Army Model MHE-228
	TM 10-3930-633-34P	Direct Support and General Support Maintenance Repair Parts and Special Tools List for Tractor, Wheeled, Warehouse, Gasoline, 4-Wheel, Pneumatic Tired, 4,000 LB DBP (Clark Equipment Co., Model 2330237), Army Model MHE-228
	TM 9-6140-200-14	Operator's, Organizational, Direct Support and General Support Maintenance Manual for Lead-Acid Storage Batteries
	TM 5-764	Electric Motor and Generator Repair
	TB 385-101	Safety Use of Cranes, Crane-Shovel Dragline, and Similar Equipment Near Electric Power Lines
A-6. Shipment and Storage		
	TB 740-93-2	Preservation of USAMEC Mechanical Equipment for Shipment and Storage
	TM 740-90-1	Administrative Storage of Equipment
A-7. Destruction of Army Materiel to Prevent Enemy Use		
	TM 750-244-6	Procedures for Destruction of Tank-Automotive Equipment to Prevent Enemy Use
A-8. Safety		
	TB MED 501	Occupational and Environmental Health: Hearing Conservation
	TB 750-1047	Elimination of Combustibles from Interiors of Metal or Plastic Gasoline and Diesel Fuel Tanks



## APPENDIX B

### MAINTENANCE ALLOCATION CHART

#### Section I. INTRODUCTION

##### B-1. General

*a.* This section provides a general explanation of all maintenance and repair functions authorized at the various maintenance levels.

*b.* The Maintenance Allocation Chart (MAC) in Section II designates overall authority and responsibility for the performance of maintenance functions on the identified end item or component. The application of the maintenance functions to the end item or component will be consistent with the capacities and capabilities of the designated maintenance levels.

*c.* Section III lists the tools and test equipment (both special tools and common tool sets) required for each maintenance function as referenced from Section II.

*d.* Section IV contains supplemental instructions and explanatory notes for a particular maintenance function.

##### B-2. Maintenance Functions

Maintenance functions will be limited to and defined as follows:

*a. Inspect.* To determine the serviceability of an item by comparing its physical, mechanical, and/or electrical characteristics with established standards through examination (e.g., by sight, sound, or feel).

*b. Test.* To verify serviceability by measuring the mechanical, pneumatic, hydraulic, or electrical characteristics of an item and comparing those characteristics with prescribed standards.

*c. Service.* Operations required periodically to keep an item in proper operating condition, i.e., to clean (includes decontaminate, when required), to preserve, to drain, to paint, or to replenish fuel, lubricants, chemical fluids, or gases.

*d. Adjust.* To maintain or regulate, within prescribed limits, by bringing into proper or exact position, or by setting the operating characteristics to specified parameters.

*e. Aline.* To adjust specified variable elements of an item to bring about optimum or desired performance.

*j. Calibrate.* To determine and cause corrections to be made or to be adjusted on instruments or test, measuring, and diagnostic equipments used in precision measurement. Consists of comparisons of two instruments, one of which is a certified standard of known accuracy, to detect and adjust any discrepancy in the accuracy of the instrument being compared.

comparing.

*g. Remove/Install.* To remove and install the same item when required to perform service or other maintenance functions. Install may be the act of emplacing, seating, or fixing into position a spare, repair part, or module (component or assembly) in a manner to allow the proper functioning of an equipment or system.

*h. Replace.* To remove an unserviceable item and install a serviceable counterpart in its place. "Replace" is authorized by the MAC and is shown as the third position of the SMR code.

*i. Repair.* The application of maintenance services, including fault location/troubleshooting, removal/installation, and disassembly/assembly procedures, and maintenance actions to identify troubles and restore serviceability to an item by correcting specific damage, fault, malfunction, or failure in a part, subassembly, module (component or assembly), end item, or system.

*j. Overhaul.* That maintenance effort (service/action) prescribed to restore an item to a completely serviceable/operational condition as required by maintenance standards in appropriate technical publications (i. e., DMWR). Overhaul is normally the highest degree of maintenance performed by the Army. Overhaul does not normally return an item to like new condition.

*k. Rebuild.* Consists of those services/actions necessary for the restoration of unserviceable equipment to a like new condition in accordance with original manufacturing standards. Rebuild is the highest degree of materiel maintenance applied to Army equipment. The rebuild operation includes the act of returning to zero those age measurements (hours/miles, etc.) considered in classifying Army equipment/components.

##### B-3. Explanation of Columns in the MAC, Section II

*a. Column 1, Group Number.* Column 1 lists functional group code numbers, the purpose of which is to identify maintenance significant components, assemblies, subassemblies, and modules with the next higher assembly. End item group number shall be "00."

*b. Column 2, Component/Assembly.* Column 2 contains the names of components, assemblies, subassemblies, and modules for which maintenance is authorized.

c. *Column 3, Maintenance Function.* Column 3 lists the functions to be performed on the item listed in Column 2. (For a detailed explanation of these functions, see paragraph B-2.)

d. *Column 4, Maintenance Level.* Column 4 specifies, by the listing of a *work time* figure in the appropriate subcolumn(s), the level of maintenance authorized to perform the function listed in Column 3. This figure represents the active time required to perform that maintenance function at the indicated level of maintenance. If the number or complexity of the tasks within the listed maintenance function vary at different maintenance levels, appropriate work time figures will be shown for each level. The work time figure represents the average time required to restore an item (assembly, subassembly, component, module, end item, or system) to a serviceable condition under typical field operating conditions. This time includes preparation time (including any necessary disassembly/assembly time), troubleshooting/ fault location time, and quality assurance/quality control time in addition to the time required to perform the specific tasks identified for the maintenance functions authorized in the Maintenance Allocation Chart. The symbol designations for the various maintenance levels are as follows:

- C ..... Operator or Crew
- O ..... Organizational Maintenance
- F ..... Direct Support Maintenance
- H ..... General Support Maintenance
- D ..... Depot Maintenance

e. *Column 5, Tools and Equipment.* Column 5 specifies, by code, those common tool sets (not indi-

vidual tools) and special tools, TMDE, and support equipment required to perform the designated function.

f. *Column 6, Remarks.* This column shall, when applicable, contain a letter code, in alphabetic order, which shall be keyed to the remarks contained in Section IV.

**B-4. Explanation of Columns in Tool and Test Equipment Requirements, Section III**

a. *Column 1, Tool or Test Equipment Reference Code.* The tool and test equipment reference code correlates with a code used in the MAC, Section II, Column 5:

b. *Column 2, Maintenance Level.* The lowest level of maintenance authorized to use the tool or test equipment.

c. *Column 3, Nomenclature.* Name or identification of the tool or test equipment.

d. *Column 4, National/NATO Stock Number.* The National or NATO Stock Number of the tool or test equipment.

e. *Column 5, Tool Number.* The manufacturer's part number.

**B-5. Explanation of Columns in Remarks, Section IV**

a. *Column 1, Reference Code.* The code recorded in Column 6, Section II.

b. *Column 2, Remarks.* This column lists information pertinent to the maintenance function being performed as indicated in the MAC, Section II.

**Section II. MAINTENANCE ALLOCATION CHART**

(1) Group Number	(2) Component/Assembly	(3) Maintenance Function	(4) Maintenance Level					(5) Tools and Equipment	(6) Remarks
			C	O	F	H	D		
01 0100	ENGINE Engine Assembly	Inspect	0.3	0.3	8.0	28.0			
		Test		1.0					
Service									
Replace									
Repair									
0101	Crankcase, Block, Cylinder Head Cylinder Head	Overhaul							
		Test	1.0						
		Replace		3.0					
		Repair		4.0					
		Overhaul			8.0				



Section II. MAINTENANCE ALLOCATION CHART – Continued

(1) Group Number	(2) Component/Assembly	(3) Maintenance Function	(4) Maintenance Level					(5) Tools and Equipment	(6) Remarks
			C	O	F	H	D		
0101	<i>Crankcase, Block, Cylinder Head (Con</i> Block Assembly, Cylinder	Replace				8.0			
		Repair				12.0			
		Overhaul				12.0			
0102	<i>Crankshaft</i>	Replace				12.0		B	
0103	<i>Flywheel Assembly</i>	Replace			1.0				
0104	<i>Pistons, Connecting Rods</i> Piston Assembly	Replace				1.5			
		Repair				2.0			
		Overhaul				3.0			
0105	<i>Valves, Camshafts, and Timing System</i> Valves	Adjust			1.5				
		Replace			6.0			C	
		Camshaft Assembly	Inspect				0.3		
			Replace				8.0		B
0105	Gear, Timing	Inspect				0.3			
		Replace				2.0			
0106	<i>Engine Lubrication System</i> Oil Filler Cap Breather	Service	0.1						
		Replace		0.1					
		Test			0.6				
		Replace			2.0				
0106	Pump, Oil	Repair				2.0			
		Overhaul				2.0			
						2.0			
0108	<i>Manifolds</i>	Replace		1.5					
<b>03</b>	<b>FUEL SYSTEM</b>								
0301	<i>Carburetor</i>	Adjust		0.5					
		Replace		1.0					
		Repair		2.0					
0302	<i>Pump, Fuel and Filter</i>	Test		0.3					
		Service		0.3					
		Replace		1.0					
		Repair		1.0					

Section II. MAINTENANCE ALLOCATION CHART - Continued

(1) Group Number	(2) Component/Assembly	(3) Maintenance Function	(4) Maintenance Level					(5) Tools and Equipment	(6) Remarks
			C	O	F	H	D		
0304	<i>Air Cleaner</i>	Inspect Service Replace	0.1	0.2 0.2					
0306	<i>Tanks, Lines and Fittings</i>								
	Fuel Lines	Inspect Replace	0.1	0.1					
	Fuel Tank	Inspect Service Replace Repair	0.1 0.2	0.6	1.5				
0308	<i>Engine Speed Governor and Controls</i>								
	Governor	Adjust Replace		0.2 0.4					
0312	<i>Accelerator and Choke Controls</i>								
	<i>Accelerator and Linkage</i>	Inspect Adjust Replace	0.1	0.3 0.5					
<b>04</b>	<b>EXHAUST SYSTEM</b>								
0401	<i>Muffler and Pipes</i>	Replace		1.0					
<b>05</b>	<b>COOLING SYSTEM</b>								
0501	<i>Radiator</i>	Inspect Test Service Replace Repair	0.1 0.2	0.3 1.5	2.0				
0503	<i>Water Manifold, Headers, Thermostats and Housing Gasket</i>								
	Thermostat	Test Replace		0.5 0.5					
	Hoses, Lines, and Fittings	Inspect Replace	0.1	0.5					
0504	<i>Water Pump</i>	Inspect Replace		0.2 0.5					

Section II. MAINTENANCE ALLOCATION CHART – Continued

(1) Group Number	(2) Component/Assembly	(3) Maintenance Function	(4) Maintenance Level					(5) Tools and Equipment	(6) Remarks
			C	O	F	H	D		
0505	Fan Assembly	Replace		0.5					
	Belts, Fan	Inspect	0.1						
		Adjust		0.2					
		Replace		0.5					
<b>06</b>	<b>ELECTRICAL SYSTEM</b>								
0601	Alternator	Test		0.5					
		Replace		0.5					
		Repair			2.0				
0602	Voltage Regulator	Test		0.5					
		Adjust		0.3					
		Replace		0.3					
0603	Starting Motor	Test		0.5					
		Replace		0.5					
		Repair			1.5				
	Relay Solenoid	Test		0.5					
		Replace		0.5					
0605	Ignition Components								
	Distributor, Ignition	Service		0.1					
		Adjust		0.2					
		Replace		0.5					
		Repair			1.0				
	Coil, Ignition	Test		0.2					
		Replace		0.3					
	Spark Plug	Adjust		0.3					
		Replace		0.4					
0607	Instrument Panel								
	Gages	Inspect	0.1						
		Replace		0.6					
0609	Lights	Inspect	0.1						
		Replace		0.4					
		Repair		0.4					
0610	Sending Units and Warning Switches	Replace		0.4					
0611	Horn	Test	0.1						
		Replace		0.3					
0612	Batteries	Test		0.2					
		Service	0.2						
		Replace		0.3					

Section II. MAINTENANCE ALLOCATION CHART - Continued

(1) Group Number	(2) Component/Assembly	(3) Maintenance Function	(4) Maintenance Level					(5) Tools and Equipment	(6) Remarks
			C	O	F	H	D		
0612	Batteries (Con't)								
	Cables, Battery	Inspect Replace	0.1	0.3					
0613	Wiring Harness	Replace		2.5					
0615	Radio Interference Sup- pression								
	Capacitor	Test Replace		0.1 0.2					
<b>07</b>	<b>TRANSMISSION</b>								
0705	Gear Shift Controls	Adjust Replace Repair		0.5	2.0 2.0				
0708	Torque Converter	Replace			0.5				
0710	Transmission Assembly	Test Service Replace Repair Overhaul	1.0		1.0 8.0	12.0 16.0			D
0713	Intermediate Clutch								
	Clutch Pack	Repair				6.0			
0714	Servo Unit								
	Transmission Actuator, Front and Rear	Replace			2.0				
0721	Coolers, Pumps, Motors								
	Regulator, Transmission	Replace Repair			0.4 0.5				
	Piping, Transmission	Inspect Replace	0.1	0.5					
	Filter, Oil	Replace		0.3					
<b>08</b>	<b>TRANSFER AND FINAL DRIVE ASSEMBLIES</b>								
0801	Power Transfer, Final Drive, Assemblies								
	Transfer Case	Service Replace		0.2	2.0				

Section II. MAINTENANCE ALLOCATION CHART – Continued

(1) Group Number	(2) Component/Assembly	(3) Maintenance Function	(4) Maintenance Level					(5) Tools and Equipment	(6) Remarks
			C	O	F	H	D		
			09	<b>PROPELLER, PROPELLER SHAFTS, UNIVERSAL JOINTS, COUPLER AND CLAMP ASSEMBLY</b>					
0900	<i>Propeller Shafts</i>	Service Replace Repair		0.2	0.3 2.0				
10	<b>FRONT AXLE</b>								
1004	<i>Steering and Leaning Wheel Mechanism</i>								
	<i>Axle Assembly, Front</i>	Service Replace Repair			0.2 4.0 4.0				
11	<b>REAR AXLE</b>								
1100	<i>Rear Axle Assembly</i>	Service Replace Repair			0.2 2.0 1.0				
1102	<i>Differential</i>	Service Replace Repair		0.2	4.0	4.0			
12	<b>BRAKES</b>								
1201	<i>Hand Brakes</i>	Inspect Adjust Replace		0.2 0.2 0.6					
	<i>Lever, Parking Brake</i>	Test Adjust Replace	0.1 0.1	0.7					
1202	<i>Service Brakes</i>	Inspect Adjust Replace Repair		0.5 0.4	2.5 1.0				
1204	<i>Hydraulic Brake System</i>								
	<i>Cylinder Assembly, Front</i>	Inspect Replace Repair		0.4	1.0 0.4				
	<i>Cylinder Assembly, Rear</i>	Inspect Replace		0.4	1.0				
	<i>Master Cylinder</i>	Service Replace	0.1	1.0					

Section II. MAINTENANCE ALLOCATION CHART - Continued

(1) Group Number	(2) Component/Assembly	(3) Maintenance Function	(4) Maintenance Level					(5) Tools and Equipment	(6) Remarks
			C	O	F	H	D		
1204	<i>Hydraulic Brake System (Con't)</i>								
	Brake Lines	Replace		1.0					
1205	<i>Vacuum System Components</i>								
	Hydrovac, Brake	Adjust Replace Repair		0.5 1.0	1.5				
1206	<i>Mechanical Brake System</i>								
	Pedal, Brake and Linkage	Adjust Replace		0.2 0.5					
<b>13</b>	<b>WHEELS</b>								
1311	<i>Wheel Assembly</i>	Replace		1.0					
	Bearings and Seals	Service Replace		0.8 0.8					
1313	<i>Tires and Tubes</i>	Inspect Service Replace Repair	0.2 0.1	1.0 0.5					
<b>14</b>	<b>STEERING</b>								
1401	<i>Mechanical Steering Gear Assembly</i>	Adjust Replace Repair		0.2	4.0 2.0				
	Draglink, Tie Rod	Service Adjust Replace Repair		0.4 1.0 2.0 0.5					E
<b>15</b>	<b>FRAME, TOWING ATTACHMENTS, DRAWBARS, AND ARTICULATION SYSTEM</b>								
1502	<i>Counterweights</i>	Replace		0.5					
1503	<i>Pintles and Towing Attachments</i>								
	Towing Attachments	Service Replace		0.1 0.5					

Section II. MAINTENANCE ALLOCATION CHART - Continued

(1) Group Number	(2) Component/Assembly	(3) Maintenance Function	(4) Maintenance Level					(5) Tools and Equipment	(6) Remarks
			C	O	F	H	D		
<b>16</b>	<b>SPRINGS AND SHOCK ABSORBERS</b>								
1601	<i>Springs</i> Leaf Springs, Front and Rear	Replace			2.0				
1604	<i>Shock Absorber Equipment</i> Bumper, Rubber	Replace			0.3				
<b>18</b>	<b>BODY, CAB AND HOOD</b>								
1801	<i>Body, Cab and Hood Assemblies</i> Hood Assembly	Service Replace		0.1 0.5					
1806	<i>Upholstery Seats and Carpets</i> Frame, Seat	Adjust Replace		0.1 0.5					
<b>22</b>	<b>BODY AND CHASSIS ACCESSORY ITEMS</b>								
2210	<i>Data Plates and Instruction Holders</i>	Replace		0.3					

Section III. TOOL AND TEST EQUIPMENT REQUIREMENTS

Not Applicable.

Section IV. REMARKS

(1) Reference Code	(2) Remarks
A	Test includes engine operation and compressor.
B	Align and resize.
C	Reface.
D	Test hydraulic control pressure.
E	





**APPENDIX C**  
**BASIC ISSUE ITEMS LIST AND ITEMS**  
**TROOP INSTALLED OR AUTHORIZED**

**Section I. INTRODUCTION**

**C-1. Scope**

This appendix lists basic issue items, items troop installed or authorized which accompany the warehouse tractor and are required by the crew/operator for operation, installation, or operator's maintenance.

**C-2. General**

This basic issue items, items troop installed or authorized list is divided into the following section:

a. *Basic Issue Items List—Section II.* (Not applicable).

b. *Items Troop Installed or Authorized List—Section III.* A list in alphabetical sequence of items which at the discretion of the unit commander may accompany the end item, but are NOT subject to be turned in with the end item.

**C-3. Explanation of Columns**

The following provides an explanation of columns

in the tabular list of Basic Issue Items List, Section II, and Items Troop Installed or Authorized, Section III.

a. *Source, Maintenance, and Recoverability Code(s) (SMR):* Not applicable.

b. *Federal Stock Number.* This column indicates the Federal stock number assigned to the item and will be used for requisitioning purposes.

c. *Description.* This column indicates the Federal item name and any additional description of the item required.

d. *Unit of Measure ( U/M).* A 2 character alphabetic abbreviation indicating the amount or quantity of the item upon which the allowances are based, e.g., ft, ea, pr, etc.

e. *Quantity Authorized ( Items Troop Installed or Authorized Only ).* This column indicates the quantity of the item authorized to be used with the equipment.

**Section III. ITEMS TROOP INSTALLED OR AUTHORIZED LIST**

(1) SMR Code	(2) Federal Stock number	(3) Description Reference number & mfg code                      Usable on code		(4) Unit of meas	(5) Qty auth
		(Not Applicable)			



INDEX

	Paragraph	Page		Paragraph	Page
Accelerator pedal and linkage:			Brake master cylinder:		
Adjustment	4-60	4-46	Installation	4-80	4-70
Inspection	4-60	4-46	Removal	4-80	4-66
Replacement	4-60	4-46	Brakes:		
Adjustment:			Brake lines	4-77	4-62
Accelerator pedal and linkage	4-60	4-46	General	4-76	4-62
Brake lining clearance	4-79	4-65	Master cylinder	4-80	4-66
Breaker point dwell	4-35	4-24	Parking brake adjustment		
Carburetor	4-57	4-44	and repair	4-81	4-70
Drag line	4-86	4-75	Service brake pedal		
Fan and alternator belts	4-66	4-53	linkage adjustment	4-77	4-62
Governor	4-59	4-45	Capacities	1-8	1-2
Ignition timing	4-38	4-26	Carburetor:		
Parking brake	3-9	3-4	Adjustment	4-57	4-44
Service brake pedal linkage	4-77	4-62	Cleaning	4-58.1	4-45
Steering gear	4-87	4-76	Disassembly	4-58.1	4-45
Steering stop screw	4-91	4-78	General	4-56	4-44
Voltage regulator	4-28	4-21	Installation	4-58	4-44
Wheel bearings	4-75	4-60	Inspection	4-58.1	4-45
Administrative storage	1-6	1-1	Reassembly	4-58.1	4-45
Air cleaner:			Removal	4-58	4-44
Cleaning and inspection	4-53	4-41	Cleaning:		
Installation	4-55	4-42	Battery	4-41	4-29
Removal	4-55	4-42	Radiator	4-67	4-54
Service	4-54	4-42	Cleaning and inspection:		
Alternator:			Accelerator pedal and linkage	4-60	4-6
General	4-25	4-20	Air cleaner	4-54	4-2
Testing	4-26	4-20	Battery	3-10	3-4
Antifreeze:			Battery cables	3-11	3-5
Freezing points, composition and			Body	4-21	4-14
specific gravities of military			Brake lines	4-77	4-62
antifreeze materials	3-8	3-3	Brake master cylinder	4-80	4-66
Axle, front:			Cylinder head	4-70	4-55
General	4-88	4-77	Drag line	4-86	4-75
Inspection	4-89	4-77	Drive axle	4-83	4-73
Lubrication	4-90	4-78	Engine oil filter	4-12	4-2
Steering stop screw adjustment	4-91	4-78	Exhaust muffler and piping	4-62	4-47
Axle, rear:			Fuel tank, fuel lines,		
General	4-82	4-73	and fittings	4-48	4-5
inspection	4-83	4-73	Ignition distributor	4-34	4-24
Lubrication	4-84	4-73	Instrument panel	4-42	4-30
Battery:			Intake and exhaust manifold	4-73	4-57
Cleaning	4-41	4-29	Lights	4-44	4-32
Cleaning and inspection	4-41	4-29	Parking brake handle		
Installation	4-41	4-29	and linkage	4-81	4-70
Removal	4-41	4-29	Spark plugs	4-31	4-23
Service	3-10	3-4	Transmission oil filter	3-4	3-2
Testing	4-41	4-29	Wheel bearings	4-75	4-60
Battery cables:			Wheels and tires	4-74	4-60
Cleaning and inspection	3-11	3-5	Controls and instruments	2-2	2-1
Installation	4-41	4-29	Coolant	4-3	4-1
Removal	4-41	4-29	Cooling system:		
Bearings, wheel	4-75	4-60	Fan and alternator belts	4-66	4-53
Belts, fan and alternator	4-66	4-53	General	4-63	4-50
Bleeding the brake system	4-78	4-64	Hoses	4-64	4-50
Body and frame:			Radiator	4-67	4-54
General	4-20	4-11	Thermostat	4-64	4-50
Inspection	4-21	4-14	Water pump	4-65	4-52
Repair	4-22	4-14	Cylinder head:		
Seat Assembly	4-23	4-14	Inspection	4-70	4-55
Brake adjustment	4-79	4-66			
Brake lines:					
Cleaning and inspection	4-77	4-62			
Removal and repair	4-77	4-62			

	Paragraph	Page		Paragraph	Page
Description:					
Body . . . . .	4-20	4-11	R e m o v a l . . . . .	4-51	4-40
Brake system . . . . .	4-76	4-62	Servicing . . . . .	4-51	4-40
Cooling system . . . . .	4-63	4-50	Fuel pump:		
Electrical system . . . . .	4-24	4-16	Installation . . . . .	4-52	4-41
Engine e . . . . .	4-68	4-55	R e m o v a l . . . . .	4-52	4-41
Exhaust system. . . . .	4-61	4-47	T e s t i n g . . . . .	4-50	4-39
Front axle . . . . .	4-88	4-77	Fuel supply . . . . .	4-46	4-35
Fuel system . . . . .	4-46	4-35	Fuel system:		
Rear axle . . . . .	4-82	4-73	Accelerator pedal and linkage	4-60	4-46
Steering System . . . . .	4-85	4-74	Air cleaner . . . . .	4-53	4-41
Destruction of materiel to			C a r b u r e t o r . . . . .	4-56	4-44
prevent enemy use, . . . . .	1-5	1-1	Fuel filter . . . . .	4-51	4-40
D i f f e r e n c e i n m o d e l s	1-9	1-4	Fuel pump . . . . .	4-49	4-39
Dimensions and weight . . . . .	1-8	1-2	Fuel tank, fuel lines		
Disassembly:			and fittings, . . . . .	4-48	4-38
Accelerator pedal and linkage	4-60	4-46	General . . . . .	4-46	4-35
Air cleaner . . . . .	4-55	4-42	G o v e r n o r a d j u s t m e n t	4-59	4-45
Drag line . . . . .	4-86	4-75	Fuel tank, fuel lines		
Exhaust muffler and piping	4-62	4-47	and fittings:		
Fuel tank, fuel lines			C l e a n i n g a n d i n s p e c t i o n	4-47	4-37
and fittings . . . . .	4-47	4-37	R e p a i r a n d r e p l a c e m e n t	4-48	4-38
Distributor:			Governor:		
Breaker point alignment . . . . .	4-36	4-24	A d j u s t m e n t . . . . .	4-59	4-45
Breaker point dwell adjustment . . . . .	4-35	4-24	Headlights . . . . .	4-43	4-31
Checks . . . . .	4-34	4-24	Hand brake, minor adjustment	3-9	3-4
Drag link:			H o r n a n d r e l a y s . . . . .	4-43	4-31
Cleaning and inspection . . . . .	4-86	4-75	Ignition coil:		
Installation and adjustment . . . . .	4-86	4-75	Check . . . . .	4-33	4-24
Removal . . . . .	4-86	4-75	Removal and replacement . . . . .	4-40	4-28
Drive axle:			Testing . . . . .	4-40	4-28
Cleaning and inspection . . . . .	4-83	4-73	Ignition distributor:		
Lubrication . . . . .	4-84	4-73	Check . . . . .	4-34	4-24
Driving truck . . . . .	2-5	2-2	Distributor point repair		
Electrical system:			and replacement . . . . .	4-35	4-24
Alternator . . . . .	4-25	4-20	R e m o v a l a n d r e p l a c e m e n t	4-39	4-27
Battery and cables, . . . . .	4-41	4-29	Testing . . . . .	4-39	4-27
General . . . . .	4-24	4-16	Ignition timing adjustment	4-38	4-26
Ignition coil, . . . . .	4-33	4-24	Ignition tune-up . . . . .	4-30	4-22
Ignition distributor . . . . .	4-34	4-24	I n s p e c t i n g a n d s e r v i c i n g e q u i p m e n t	4-1	4-1
Instrument panel . . . . .	4-44	4-32	Installation:		
Lights . . . . .	4-43	4-31	Accelerator pedal and linkage	4-60	4-46
Spark plug s . . . . .	4-31	4-23	Air-cleaner . . . . .	4-55	4-42
Starting motor . . . . .	4-29	4-21	Alternator . . . . .	4-27	4-20
Voltage regulator . . . . .	4-28	4-21	Battery . . . . .	4-41	4-29
Engine:			Battery cables . . . . .	4-41	4-29
Coolant' . . . . .	3-8	3-3	Brake master cylinder		
Cylinder head . . . . .	4-70	4-55	and brake lines . . . . .	4-80	4-66
Description . . . . .	4-68	4-55	Carburetor . . . . .	4-58	4-44
Intake and exhaust manifold . . . . .	4-73	4-57			
Oil filter . . . . .	3-3	3-1	Drag link . . . . .	4-86	4-75
Oil service . . . . .	3-3	3-1	Exhaust muffler and piping	4-62	4-47
Equipment serviceability criteria . . . . .	1-4	1-1	Fuel filter . . . . .	4-51	4-40
Errors reporting of . . . . .	1-3	1-1	F u e l p u m p . . . . .	4-52	4-41
Exhaust muffler and piping:			Fuel tank, fuel lines		
General . . . . .	4-61	4-47	and fittings . . . . .	4-47	4-37
Inspection and replacement . . . . .	4-62	4-47	Ignition coil . . . . .	4-40	4-28
Exhaust system:			Ignition distributor . . . . .	4-39	4-27
Exhaust muffler and piping . . . . .	4-61	4-47	Instrument panel . . . . .	4-42	4-30
Fan and alternator belts:			Intake and exhaust manifold . . . . .	4-73	4-57
Adjustment, . . . . .	4-66	4-53	Lights . . . . .	4-45	4-32
Replacement . . . . .	4-66	4-53	Parking brake . . . . .	4-81	4-70
Filter service:			Radiator . . . . .	4-67	4-54
Transmission oil filter . . . . .	3-4	3-2	Seat assembly . . . . .	4-23	4-14
Fuel filter:			Spark plugs . . . . .	4-31	4-23
Installation . . . . .	4-51	4-40	Starting motor . . . . .	4-29	4-21
			Thermostat . . . . .	4-64	4-50

	Paragraph	Page		Paragraph	Page
Transmission oil filter and lines . . . . .	4-13	4-2	Cleaning and inspection	4-81	4-70
Voltage regulator . . . . .	4-28	4-21	Installation . . . . .	4-81	4-70
Wheels and tires . . . . .	4-74	4-60	Removal . . . . .	4-81	4-70
Intake and exhaust manifold:			Parking brake system:		
Cleaning and inspection . . . . .	4-73	4-57	Description . . . . .	4-76	4-62
Installation . . . . .	4-73	4-57	Preparation for startup . . . . .	2-3	2-2
Removal . . . . .	4-73	4-57	Preventive maintenance checks and services . . . . .	3-5	3-2
Interference suppression			Radiator:		
Primary.. . . . .	4-17	4-10	Cleaning . . . . .	4-67	4-54
R e p l a c e m e n t	4-18	4-10	I n s p e c t i o n a n d t e s t i n g	4-67	4-54
Secondary . . . . .	4-17	4-10	Installation . . . . .	4-67	4-54
Testing . . . . .	4-19	4-11	Removal . . . . .	4-67	4-54
Introduction:			Radio interference suppression	4-16	4-10
Administrative storage . . . . .	1-6	1-1	Reassembly:		
Destruction of materiel to prevent enemy use . . . . .	1-5	1-1	Accelerator pedal and linkage	4-60	4-46
Equipment serviceability criteria . . . . .	1-4	1-1	Air cleaner . . . . .	4-55	4-42
Maintenance forms and records . . . . .	1-2	1-1	Alternator . . . . .	4-25	4-20
Reporting of errors . . . . .	1-3	1-1	Carburetor. . . . .	4-58.1	4-45
Scope . . . . .	1-1	1-1	Drag line . . . . .	4-86	4-75
Lamp replacement . . . . .	4-45	4-32	Exhaust muffler and piping . . . . .	4-62	4-47
Lights:			Fuel tank, fuel lines and fittings . . . . .	4-47	4-37
Cleaning and inspection . . . . .	4-44	4-32	Lights . . . . .	4-45	4-32
Lamp replacement . . . . .	4-45	4-32	Transmission oil filter and lines . . . . .	4-13	4-2
Replacement . . . . .	4-45	4-32	Wheel bearings . . . . .	4-75	4-60
Lubrication:			Records and forms . . . . .	1-2	1-1
Detailed lubrication information	4-11	4-2	Removal:		
General lubrication information . . . . .	4-10	4-2	Accelerator pedal and linkage	4-60	4-46
Maintenance repair parts . . . . .	4-9	4-2	A i r c l e a n e r . . . . .	4-55	4-42
Master cylinder, brake . . . . .	4-80	4-66	Alternator . . . . .	4-27	4-20
Mobile operation . . . . .	2-5	2-2	Battery . . . . .	4-41	4-29
Movement to a new worksite . . . . .	4-6	4-2	B a t t e r y c a b l e s	4-41	4-29
Oil service:			Brake master cylinder . . . . .	4-80	4-66
Engine . . . . .	3-3	3-1	Carburetor . . . . .	4-58	4-44
Transmission . . . . .	3-4	3-2	Drag line . . . . .	4-86	4-75
O p e r a t i o n :			Exhaust muffler and piping . . . . .	4-62	4-47
In extreme cold . . . . .	2-11	2-3	Fuel filter . . . . .	4-51	4-40
In extreme heat . . . . .	2-10	2-3	Fuel pump . . . . .	4-52	4-41
In humid climates . . . . .	2-12	2-4	Ignition coil . . . . .	4-40	4-28
In dusty conditions . . . . .	2-13	2-4	Ignition distributor . . . . .	4-39	4-27
Under usual conditions . . . . .	2-1	2-1	Instrument panel . . . . .	4-42	4-30
Operation under usual conditions:			Intake and exhaust manifold . . . . .	4-73	4-57
Controls and instruments . . . . .	2-2	2-1	Lights . . . . .	4-45	4-32
Driving truck . . . . .	2-5	2-2	Radiator. . . . .	4-67	4-54
General . . . . .	2-1	2-1	Seat assembly . . . . .	4-23	4-14
Preparation for start-up . . . . .	2-3	2-2	Spark plugs . . . . .	4-31	4-23
Starting the engine . . . . .	2-3	2-2	Starting motor . . . . .	4-29	4-21
Stopping the engine . . . . .	2-4	2-2	Thermostat . . . . .	4-64	4-50
Stopping the tractor . . . . .	2-7	2-3	Transmission oil filter and lines . . . . .	3-4	3-2
Towing operations . . . . .	2-6	2-2	Voltage regulator . . . . .	4-28	4-21
Operation under unusual conditions:			Wheel bearings . . . . .	4-75	4-60
In extreme cold . . . . .	2-11	2-3	Wheels and tires . . . . .	4-74	4-60
In extreme heat . . . . .	2-10	2-3	Replacement:		
In humid climates . . . . .	2-12	2-4	Fan and generator belts . . . . .	4-66	4-53
In dusty conditions . . . . .	2-13	2-4	Reporting of errors . . . . .	1-3	1-1
Operator's maintenance:			Safety precautions . . . . .	2-8	2-3
Battery service . . . . .	3-10	3-4	Scope . . . . .	1-1	1-1
Engine coolant . . . . .	3-8	3-3	Seat assembly:		
Fuel supply . . . . .	3-7	3-2	Installation . . . . .	4-23	4-14
Preventive maintenance checks and services . . . . .	3-5	3-2	Removal . . . . .	4-23	4-14
Organizational preventive maintenance checks and services . . . . .	4-14	4-3	Service:		
Packing, wheel bearing . . . . .	4-75	4-60	Air cleaner . . . . .	4-54	4-42
Parking brake handle and linkage:			F u e l f i l t e r . . . . .	4-51	4-40
Adjustment. . . . .	4-81	4-70	Battery . . . . .	3-10	3-4

	Paragraph	Page		Paragraph	
Engine: .....	3-3	3-1	Starting motor	1-8	1-2
Transmission .....	3-4	3-2	Transmission	1-8	1-2
Service brake system:			Wheels and tires	1-8	1-2
Description	4-76	4-62	Testing:		
Service brakes:			Alternator	4-26	4-20
Adjustment	4-79	4-65	Battery	4-41	4-29
Bleeding the brake system	4-78	4-64	Fuel pump	4-50	4-39
Cleaning and inspection	4-77	4-62	Ignition coil	4-40	4-28
Service upon receipt of materiel:			Starting motor	4-29	4-21
Inspecting and servicing equipment	4-1	4-1	Testing and adjustment:		
Lubrication	4-5	4-1	Voltage regulator	4-28	4-21
Operational check	4-4	4-1	Thermostat:		
Preliminary checks and services	4-3	4-1	Inspecting and testing	4-64	4-50
Preliminary inspection	4-2	4-1	Replacement	4-64	4-50
Service:			Tires:		
Battery	3-7	3-2	Tabulated data	1-8	1-2
Fuel filter	4-51	4-40	Tools and equipment	4-7	4-2
Engine	3-4	3-2	Towing operations	2-6	2-2
Spark plugs:			Transmission:		
Cleaning and inspection	4-32	4-23	Oil filter and lines	3-4	3-2
Installation	4-32	4-23	Oil service	3-4	3-2
Removal	4-32	4-23	Tabulated data	1-8	1-2
Special tools and equipment	4-8	4-2	Transmission oil filter and lines:		
Starting the engine	2-4	2-2	Cleaning and inspection	3-4	3-2
Starting motor:			Filter service	3-4	3-2
Installation	4-29	4-21	Troubleshooting (operator's)	3-12	3-5
Removal	4-29	4-21	Troubleshooting (organizational)	4-15	4-5
Testing	4-29	4-21			
Steering:			Voltage regulator:		
General	4-85	4-74	Installation	4-28	4-21
Drag link	4-86	4-75	Removal	4-28	4-21
Steering gear adjustments	4-87	4-76	Testing and adjustment	4-28	4-21
Steering system:			Water pump:		
Description	4-85	-74	Inspection	4-65	4-52
Stopping the tractor	2-7	2-3	Removal and replacement	4-65	4-52
Storage, administrative	1-6	1-1	Wheel bearings:		
Tabulated data:			(leaning and inspection)	4-75	4-60
Alternator	1-8	1-2	Packing	4-75	4-60
Battery	1-8	1-2	Reassembly	4-75	4-60
Capacities	1-8	1-2	Removal and disassembly	4-75	4-60
Dimensions and weights	1-8	1-2	Wheel removal and replacement	4-74	4-60
Engine	1-8	1-2			

By Order of the Secretary of the Army:

Official:

VERNE L. BOWERS

*Major General, United States Army,  
The Adjutant General.*

FRED C. WEYAND

*General, United States Army,  
Chief of Staff.*

Distribution:

To be distributed in accordance with DA Form 12-25B, (qty rqr block no. 485)  
Operator maintenance requirements for Tractor, Wheeled: Light.







# SOMETHING WRONG WITH THIS MANUAL?

THEN... JOT DOWN THE DOPE ABOUT IT ON THIS FORM, TEAR IT OUT, FOLD IT AND DROP IT IN THE MAIL!

FROM: (YOUR UNIT'S COMPLETE ADDRESS)

PFC JOHN DOE  
COA, 3<sup>rd</sup> ENGINEER BN  
FT. LEONARD WOOD MO 63108

DATE 16 DEC 74

PUBLICATION NUMBER

TM 5-6115-200-20 AND P

DATE

1 APR 72

TITLE

GENERATOR SET 10 KW  
NSN 6115-00-231-7296

BE EXACT... PIN-POINT WHERE IT IS

IN THIS SPACE TELL WHAT IS WRONG AND WHAT SHOULD BE DONE ABOUT IT:

PAGE NO.

PARA-GRAPH

FIGURE NO.

TABLE NO.

6

2-1  
a

In line 6 of paragraph 2-1 a the manual states the engine has 6 cylinders. The engine on my set only has 4 cylinders. Change the manual to show 4 cylinders

81

4-3

Callout 16 on figure 4-3 is pointing at a bolt. In the key to fig. 4-3, item 16 is called a shim. Please correct one or the other.

125 line 20

I ordered a gasket, item 19 on figure B-16 by NSN 2910-00-762-3001. I got a gasket but it doesn't fit. Supply says I got what I ordered so the NSN is wrong. Please give me a good NSN

TYPED NAME, GRADE OR TITLE, AND TELEPHONE NUMBER

JOHN DOE, PFC (268) 317-7111

SIGN HERE:

John Doe

DA FORM 2028-2 (TEST)

1 AUG 74

P.S.—IF YOUR OUTFIT WANTS TO KNOW ABOUT YOUR MANUAL "FIND," MAKE A CARBON COPY OF THIS AND GIVE IT TO YOUR HEADQUARTERS.

FILL IN YOUR  
UNIT'S ADDRESS

FOLD BACK

DEPARTMENT OF THE ARMY

POSTAGE AND FEES PAID  
DEPARTMENT OF THE ARMY

DOD-314

OFFICIAL BUSINESS

PENALTY FOR PRIVATE USE, \$300

Commander  
U.S. Army Troop Support Command  
ATTN: AMSTS-MPP  
4300 Goodfellow Boulevard  
St. Louis, Missouri 63120

FOLD BACK

TEAR  
ALONG DOTTED LINE



FILL IN YOUR  
UNIT'S ADDRESS

FOLD BACK

DEPARTMENT OF THE ARMY

POSTAGE AND FEES PAID  
DEPARTMENT OF THE ARMY

DOD-314

OFFICIAL BUSINESS

PENALTY FOR PRIVATE USE, \$300

Commander  
U.S. Army Troop Support Command  
ATTN: AMSTS-MPP  
4300 Goodfellow Boulevard  
St. Louis, Missouri 63120

FOLD BACK

LONG DOTTED LINE

# SOMETHING WRONG WITH THIS MANUAL?



THEN...JOT DOWN THE DOPE ABOUT IT ON THIS FORM, TEAR IT OUT, FOLD IT AND DROP IT IN THE MAIL!

FROM: (YOUR UNIT'S COMPLETE ADDRESS)

DATE

PUBLICATION NUMBER

DATE

TITLE

BE EXACT...PIN-POINT WHERE IT IS

IN THIS SPACE TELL WHAT IS WRONG AND WHAT SHOULD BE DONE ABOUT IT:

PAGE NO.

PARA-GRAPH

FIGURE NO.

TABLE NO.

TEAR ALONG DOTTED LINE

PRINTED NAME, GRADE OR TITLE, AND TELEPHONE NUMBER

SIGN HERE:

FILL IN YOUR  
UNIT'S ADDRESS

FOLD BACK

DEPARTMENT OF THE ARMY

POSTAGE AND FEES PAID  
DEPARTMENT OF THE ARMY

DOD-314

OFFICIAL BUSINESS

PENALTY FOR PRIVATE USE, \$300

Commander  
U.S. Army Troop Support Command  
ATTN: AMSTS-MPP  
4300 Goodfellow Boulevard  
St. Louis, Missouri 63120

FOLD BACK

TEAR  
NG DOTTED LINE



US ARMY NAVAL AIR FORCE DOCUMENT CENTER  
TECHNICAL LIBRARY



This fine document...

Was brought to you by me:



## [Liberated Manuals -- free army and government manuals](#)

Why do I do it? I am tired of sleazy CD-ROM sellers, who take publicly available information, slap “watermarks” and other junk on it, and sell it. Those masters of search engine manipulation make sure that their sites that sell free information, come up first in search engines. They did not create it... They did not even scan it... Why should they get your money? Why are not letting you give those free manuals to your friends?

I am setting this document FREE. This document was made by the US Government and is NOT protected by Copyright. Feel free to share, republish, sell and so on.

I am not asking you for donations, fees or handouts. If you can, please provide a link to [liberatedmanuals.com](http://liberatedmanuals.com), so that free manuals come up first in search engines:

<A HREF=<http://www.liberatedmanuals.com/>>Free Military and Government Manuals</A>

- Sincerely  
Igor Chudov  
<http://igor.chudov.com/>
- [Chicago Machinery Movers](#)