

Traditional 6 Foot Picnic Table



Plans & Instructions

You won't need any fancy tools to build this traditional picnic table. All it requires are basic tools like a saw, a drill, and an adjustable wrench. This plan is based on a time honored classic design. For the prototype, I used treated lumber for the legs and regular pine for the rest of the parts. Pine will last for several years if kept painted. If you want to spend the extra money, you can make the whole thing from redwood. That was the wood of choice for picnic tables back when the supply of redwood was better and the prices were more affordable.

Revised: July 4, 2006

Traditional Picnic Table Plans

Table of Contents

Materials List	1
End & Side Views	2
Parts Dimensions	3
Hole Layout	4
Cutout Diagrams	5
Mounting the Wheels	6
Attach the Stiffeners	7
Attach the Seats & Legs	8
Attach the Top & Braces	9
How the Wheels Work	10

Introduction

Thank you for purchasing our Picnic Table Plans. Please read these instructions before starting.

I recommend you make the legs from treated lumber because they will have ground contact. The rest of the parts could be made from treated wood too, except the top. Since food will be served and eaten from the top, I recommend untreated wood for it. If kept painted, regular pine will last for several years.

These plans include the use of wheels on two legs. The way the wheels are mounted keeps the weight on the legs when the table is sitting flat but the weight shifts to the wheels when the side of the table without the wheels is lifted. This allows for easy moving of the table when necessary. Of course, the wheels are optional, and they can always be added later if desired.

These plans also include the use of four simple strips of $\frac{3}{4}$ " by $1\frac{1}{2}$ " wood that I call Leg Protectors. Their purpose is to keep people's legs from getting scratched on the ends of the bolts that secure the seat supports to the picnic table legs.

Traditional Picnic Table Plans Materials List

Qty	Item	Length	Material
5	Top Boards	72"	2 by 6
4	Seat Boards	72"	2 by 6
2	Seat Supports	57"	2 by 6
2	End Top Supports	26"	2 by 4
3	Top Stiffeners	26"	2 by 4
6	Seat Stiffeners	10"	2 by 4
4	Leg Protectors	10"	3/4 by 1 1/2
2	Braces	30 1/4"	2 by 4
4	Legs	32"	2 by 6
16	3/8" Carriage Bolts	3 1/2"	Galvanized
16	3/8" Flat Washers		Galvanized
16	3/8" Self Locking Nuts		Galvanized
20	#8 Deck Screws	3"	
54	#8 Deck Screws	2 1/2"	
8	#8 Deck Screws	1 5/8"	
2	6" Wheels		Plastic
2	* 1/2" Hex Head Bolts	4"	Galvanized
4	* 1/2" Flat Washers		Galvanized
2	* 1/2" Self Locking Nuts		Galvanized

*The diameter of these bolts depends on the axle hole diameter of the wheels you use. For the wheels, I recommend plastic hubs and rubber tires because of rust concerns.

Traditional Picnic Table Plans - End & Side Views

Page 2

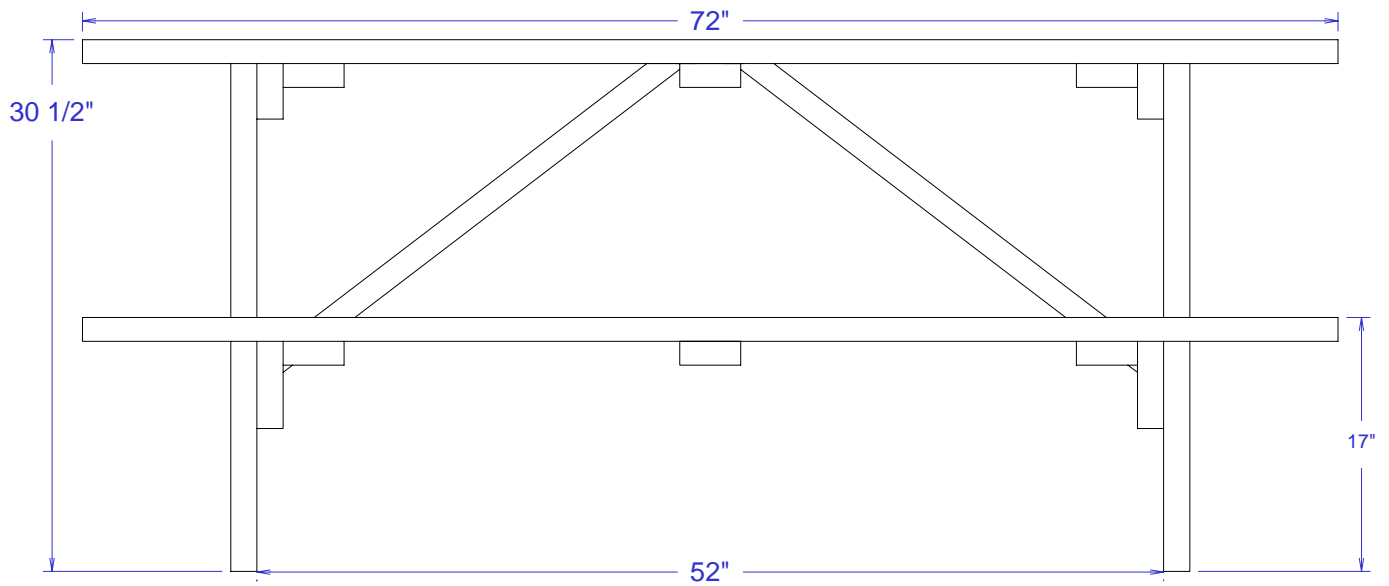
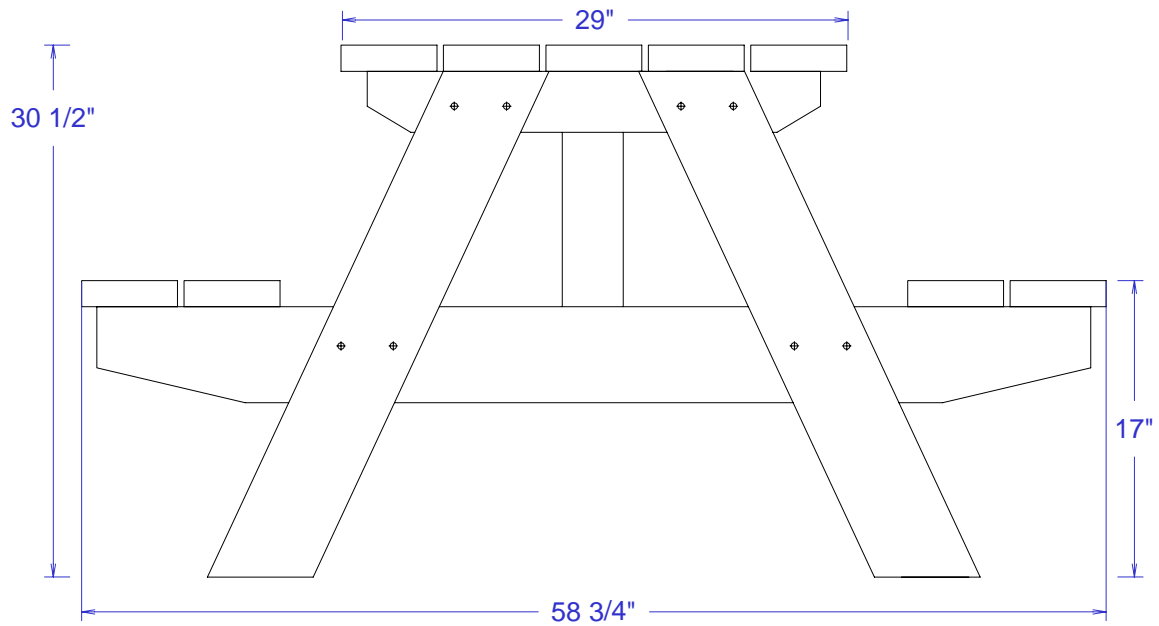

Traditional Picnic Table Plans - Parts Dimensions

Notice: Before cutting the parts, be sure to look over the cutout drawings on page 5 .
The Legs should be cut at the indicated angles and lengths as shown.
Otherwise, there will be wasted wood.

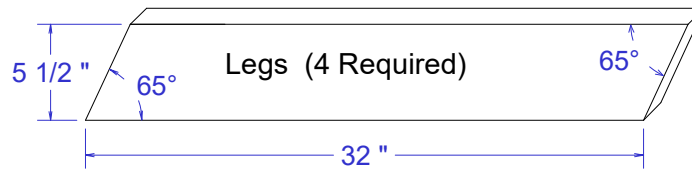
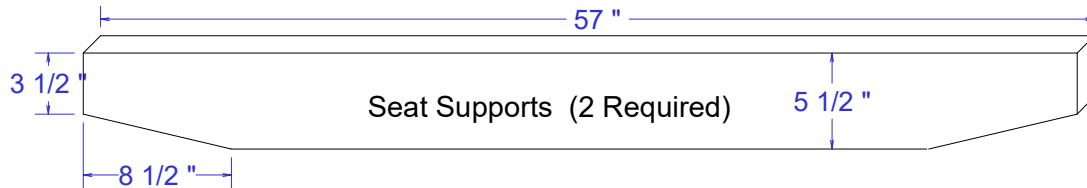

Note: To get the 65° angles, you may need to set your miter saw to 25°. This is because the scales on most miter saws are set so that a 90° cut is labeled as 0° on the scale.

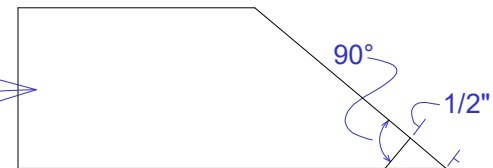
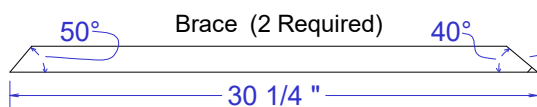
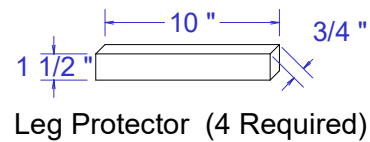
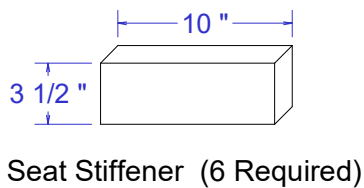
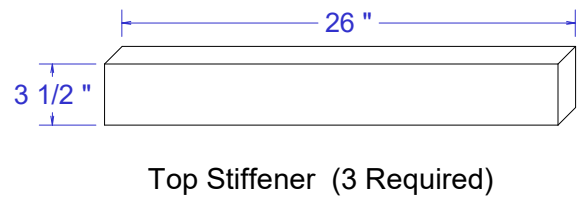
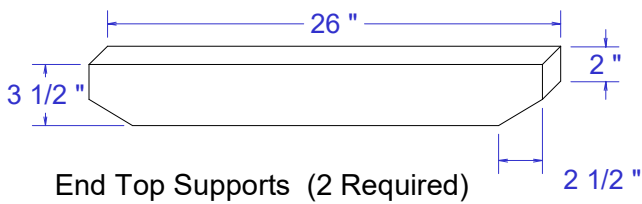

Cut off a section of the end braces as shown in the detail view above.

Traditional Picnic Table Plans - Hole Layout

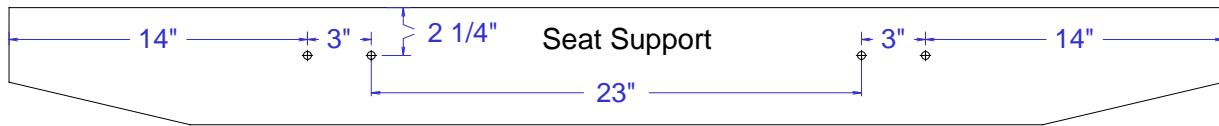

Drill four 3/8" holes in the Seat Supports for the Legs as shown

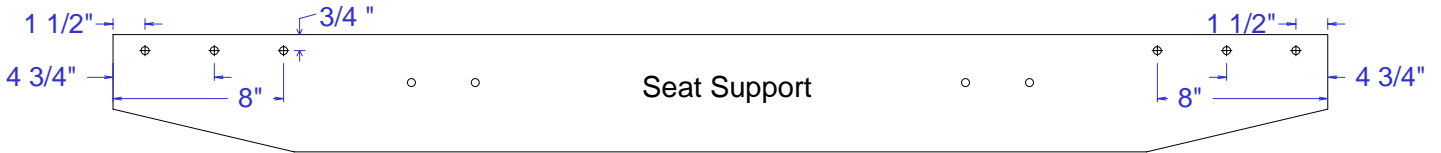

Drill six 3/16" diameter holes in the Seat Supports and countersink them for #8 deck screws as shown. These holes are for mounting the Seat Stiffeners to the End Top Supports.

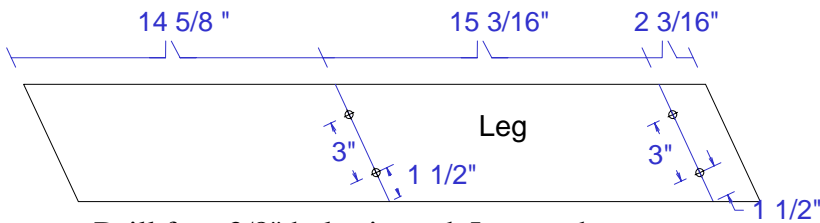

Drill four 3/8" holes in each Leg as shown



Drill & countersink four holes in the Seat Stiffeners for #8 screws.

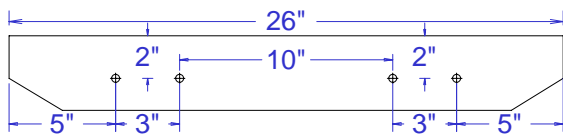

Drill four 3/8" holes in the End Top Supports. These holes will be used for mounting the legs.

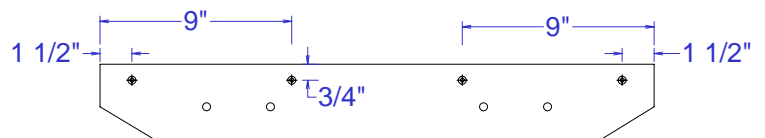

Drill & countersink four holes in the End Top Supports for #8 deck screws for mounting the stiffeners to the End Top Supports.

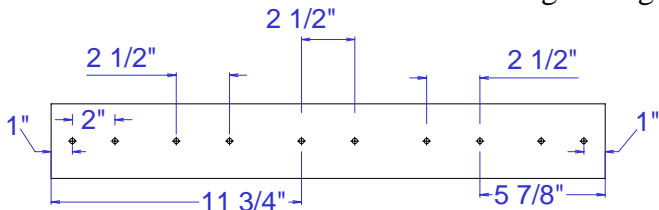

Top Stiffener

Drill & countersink ten holes in the Top Stiffeners for # 8 screws.



Leg Protector

Drill & countersink two 3/16" holes in the Leg Protectors - 1 1/2" from from each end and centered top to bottom. Round off the outer edges on all four sides so they don't scratch anyones legs.

Drill & countersink two holes on the ends of the braces for # 8 screws as shown.



Cut the 3 1/3" wide pieces from three 8' two by fours as shown.

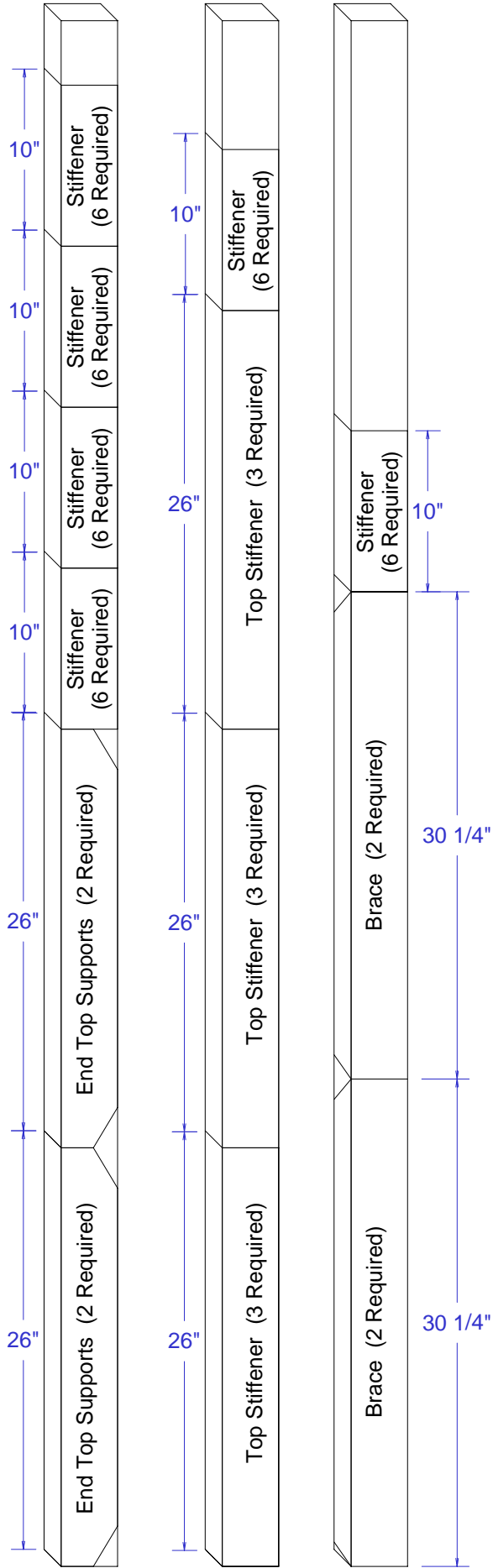

Cut the legs from two 6' treated two by sixes as shown.

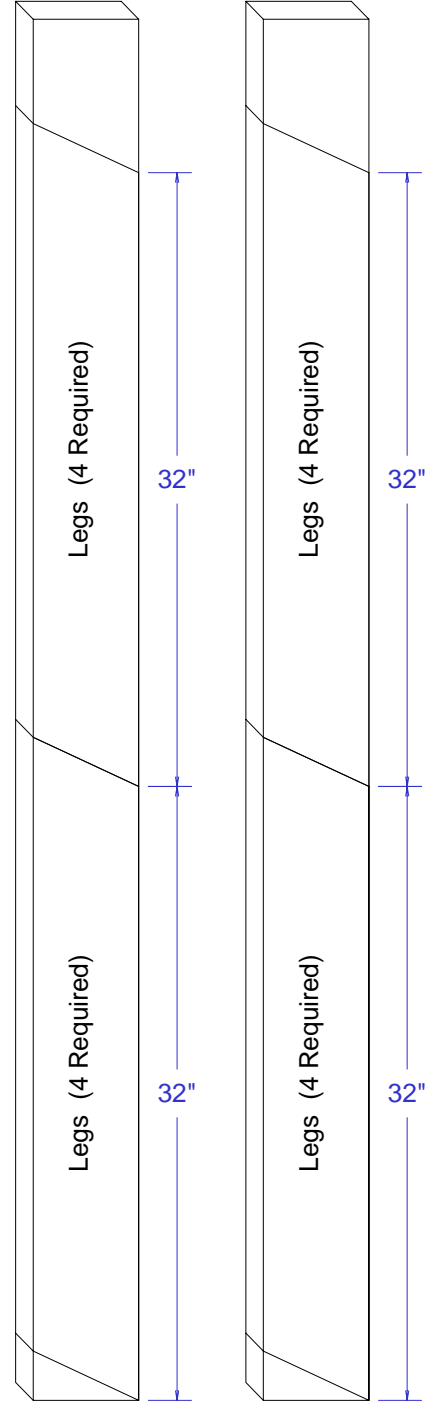

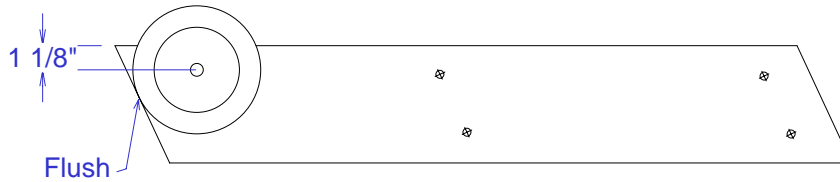

Wheels that are labeled 6" may not be exactly 6" in diameter. So, you'll need to place your wheel on the bottom of the leg as shown. The center of the axle hole should be 1 1/8" from the edge and the edge should be flush with the bottom of the leg as shown. Make a mark through the axle hole and drill a 1/2" hole, (or the diameter of the axle hole for your wheels), for the axle bolt in the marked position.

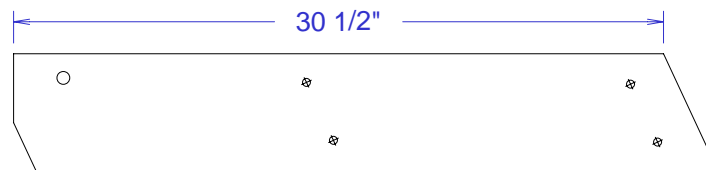

Cut off the end so the edge closest to the axle hole is 32 1/2" long as shown.

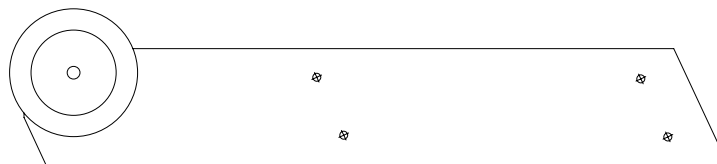

Mount the wheels with 3 1/2" by 1/2" diameter (or the diameter of the axle hole for your wheels) hex head bolts. You should place a flat washer between the wheel and the leg and between the nut and the leg.. I recommend using galvanized bolts, nuts, and washers.

You'll need to use self-locking nuts because the wheels won't turn if you tighten them against the leg. Tighten them just enough so the wheels are not too sloppy.

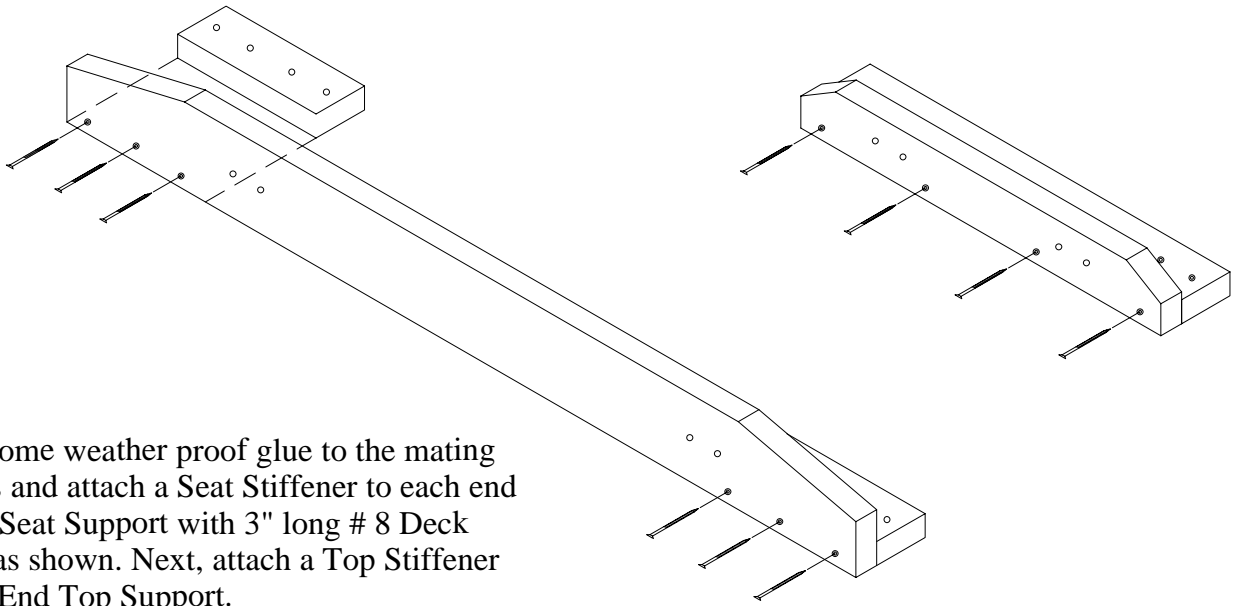

Apply some weather proof glue to the mating surfaces and attach a Seat Stiffener to each end of each Seat Support with 3" long # 8 Deck screws as shown. Next, attach a Top Stiffener to each End Top Support.

Arrange the 5 top boards as shown with a 3/8" gap between each board. Attach the two Top Supports (stiffeners should already be attached) to the top boards with 2 1/2" deck screws as shown. (Be sure the top boards line up properly and the ends are flush and square. Also be sure the center support is centered from end to end.)

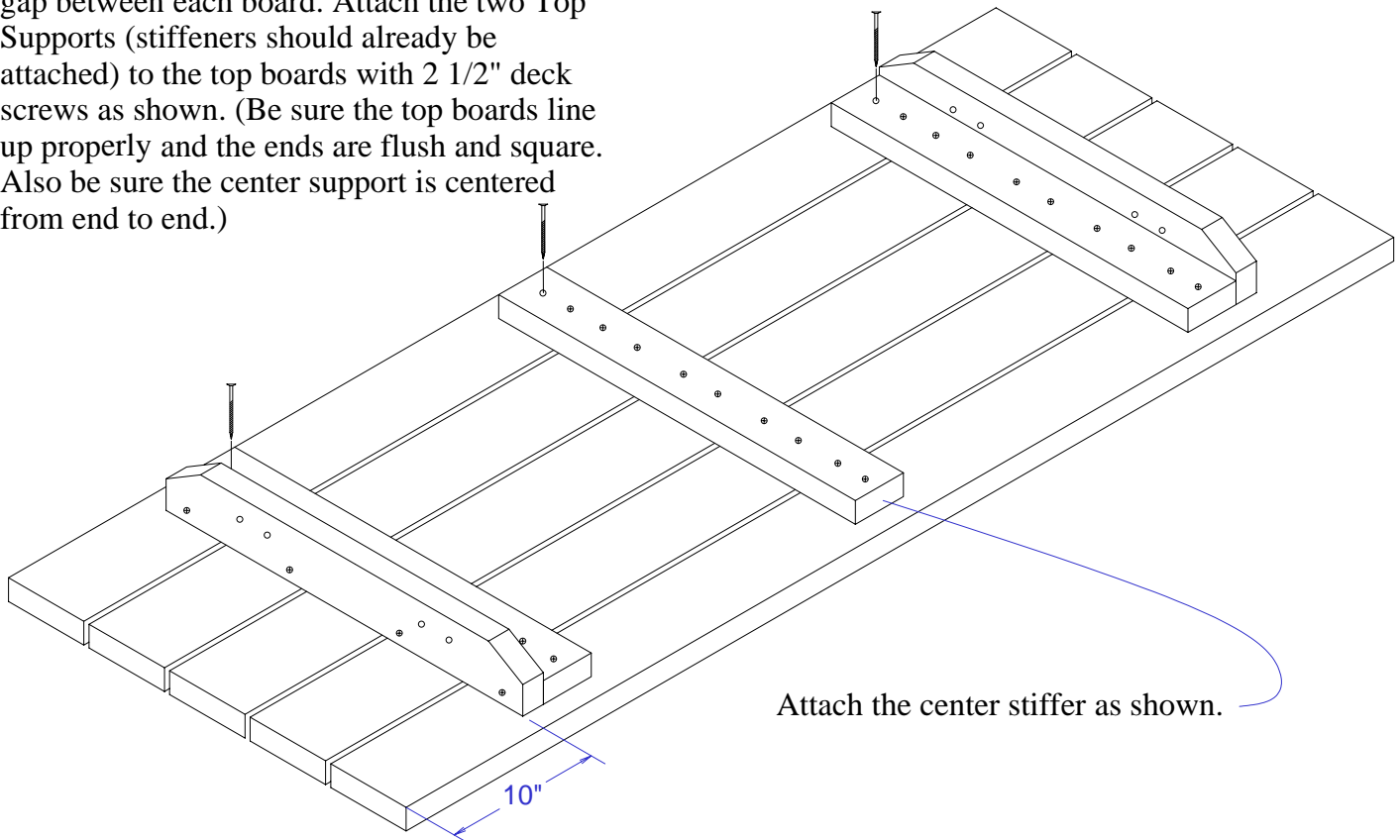

Attach the center stiffer as shown.

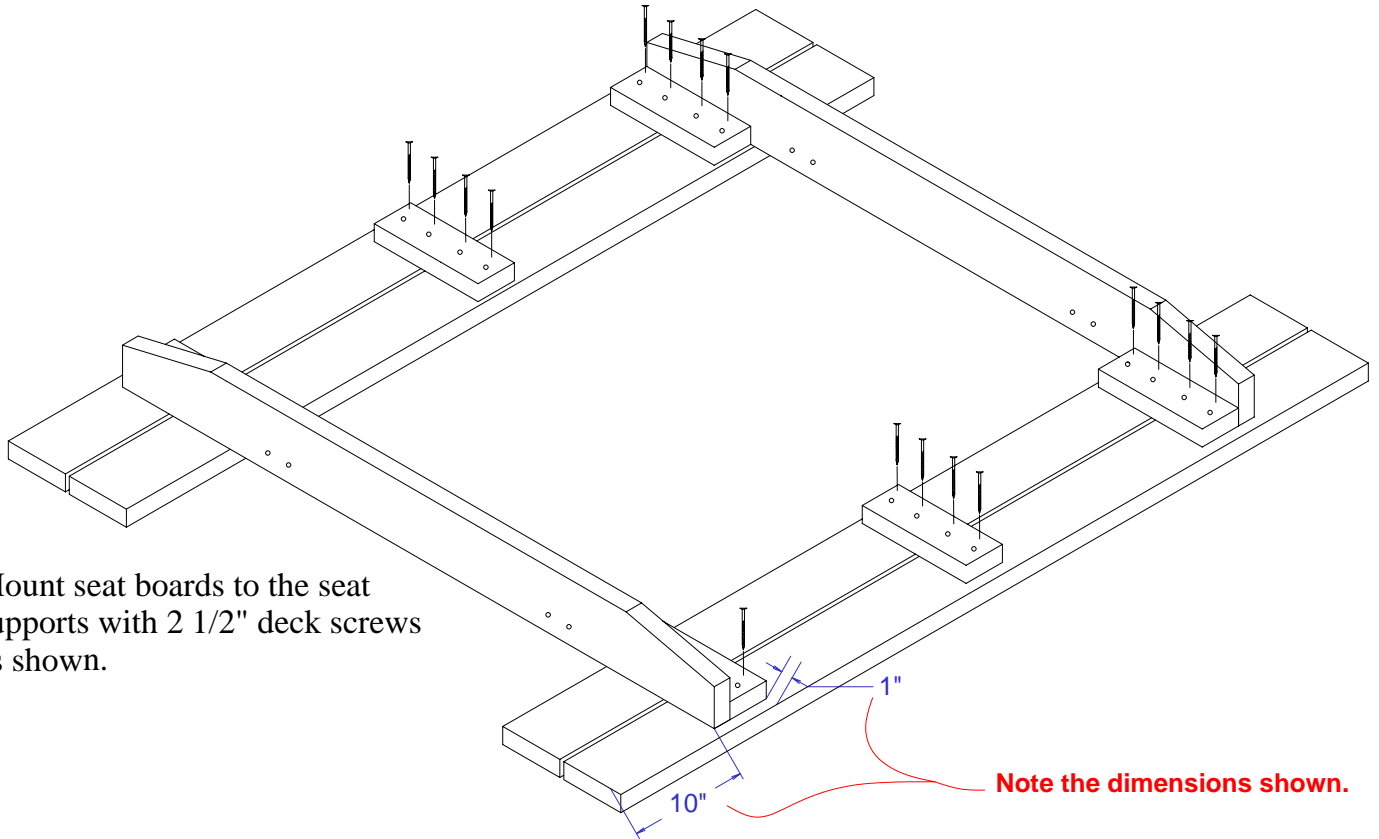

Mount seat boards to the seat supports with 2 1/2" deck screws as shown.

Note the dimensions shown.

Mount the legs to the Seat Supports with 3 1/2" long 3/8" diameter galvanized carriage bolts as shown. Use flat washers for the side the nuts go on. can tighten them after you have finished mounting the top assembly.

Leave these bolts snug for now. You can tighten them after mounting the top assembly.

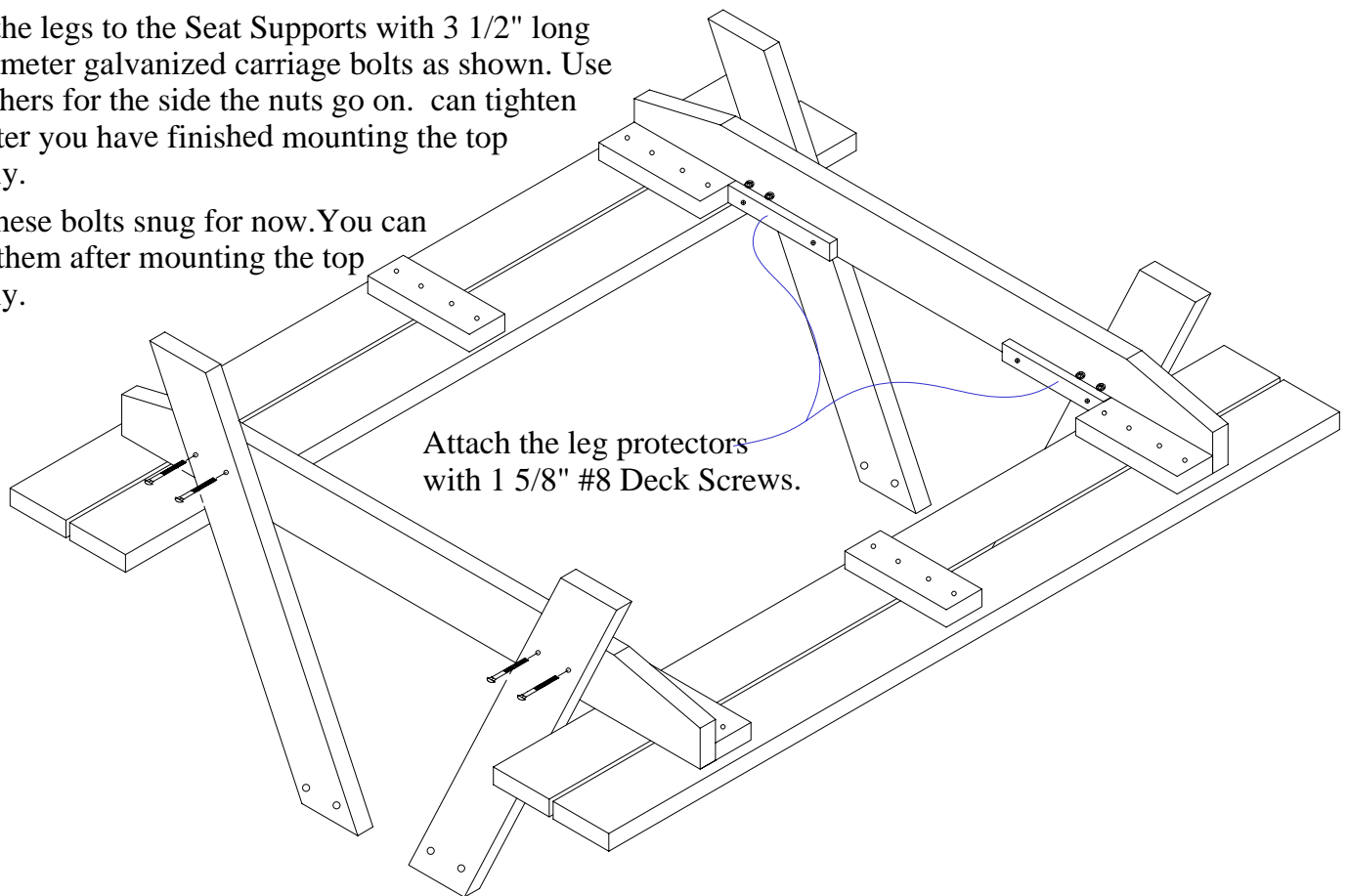

Attach the leg protectors with 1 5/8" #8 Deck Screws.

Traditional Picnic Table Plans - Attach the Top & Braces

Page 9

Mount the legs to the Top Supports with 3 1/2" long 3/8" diameter galvanized carriage bolts as shown. Now you can tighten all the bolts for the seat assembly and the top supports..

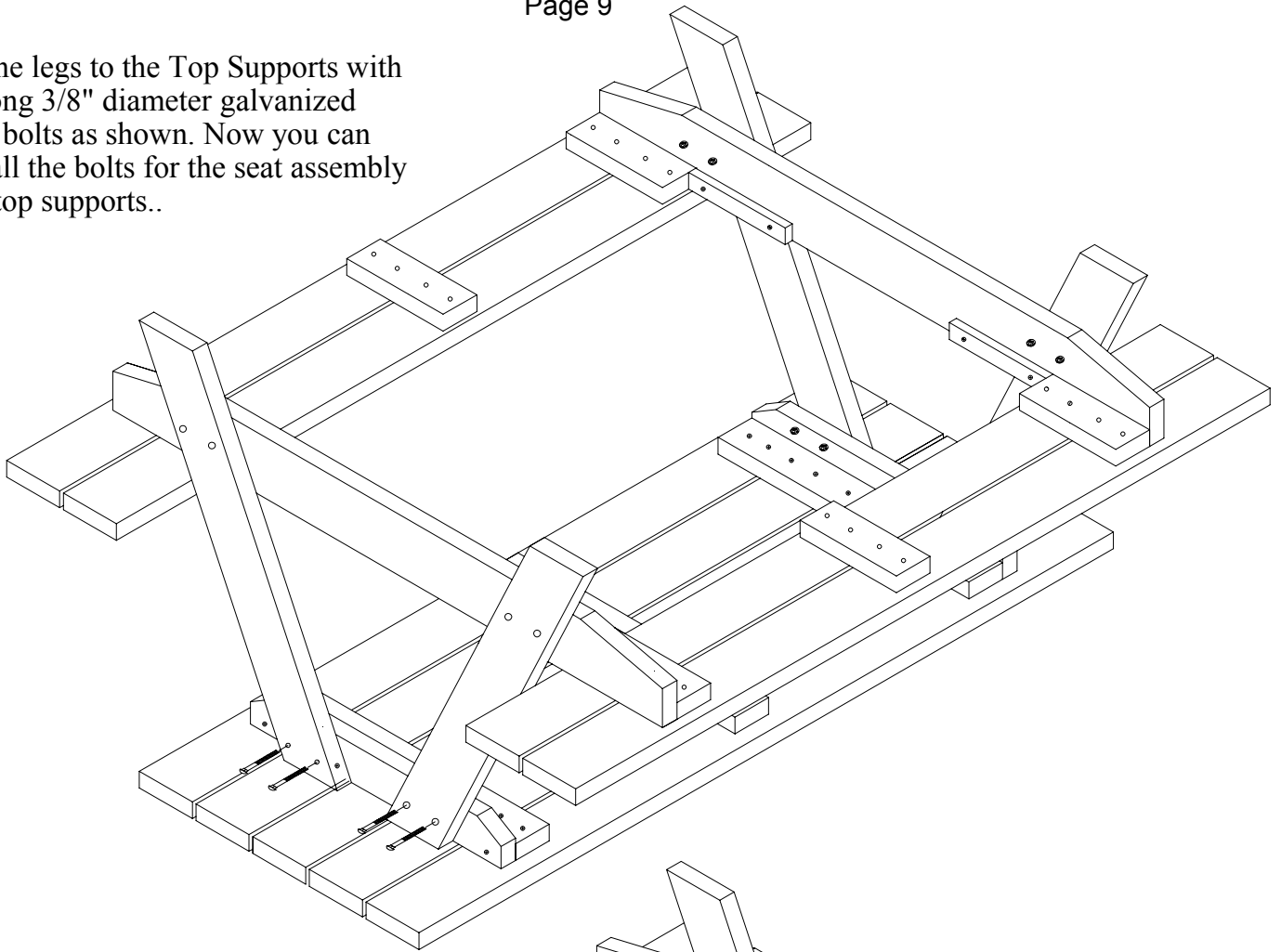

Mount the braces to the seat supports and top as shown. The end of the braces with 40° tip goes against the center top stiffener. Page 2 gives a good illustration of how the braces are placed.

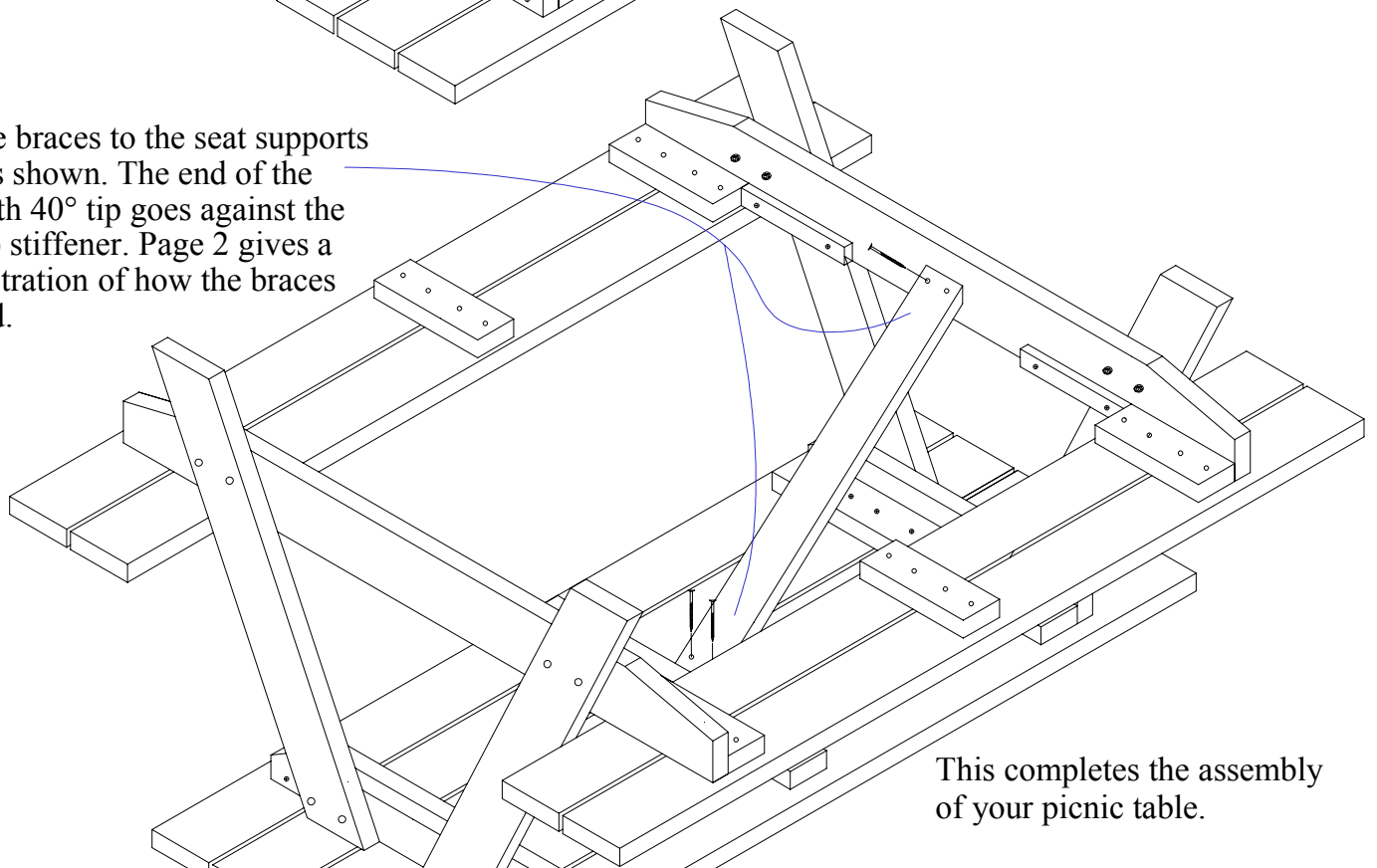

This completes the assembly of your picnic table.

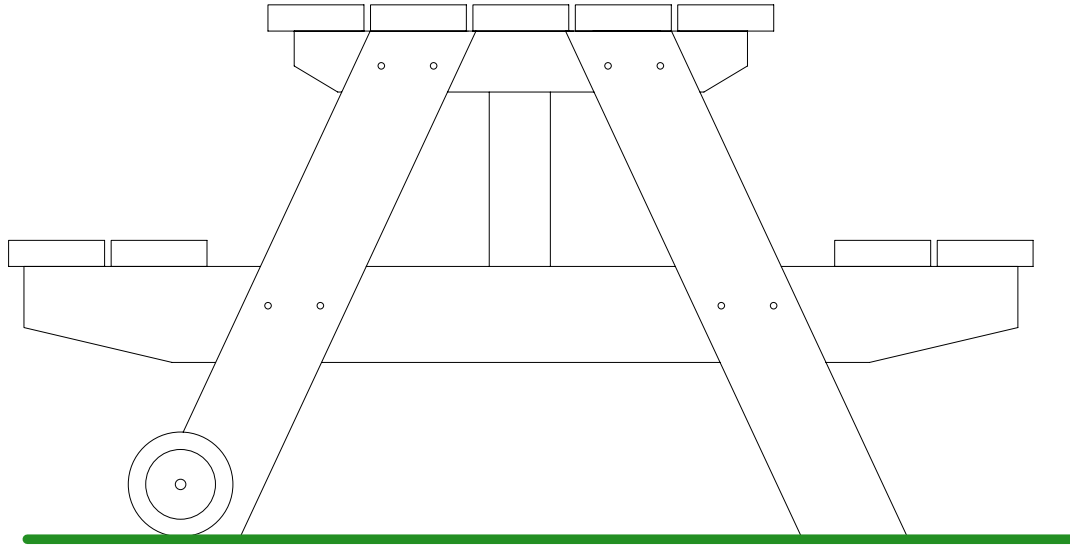

In the normal position, the weight is supported by the legs.

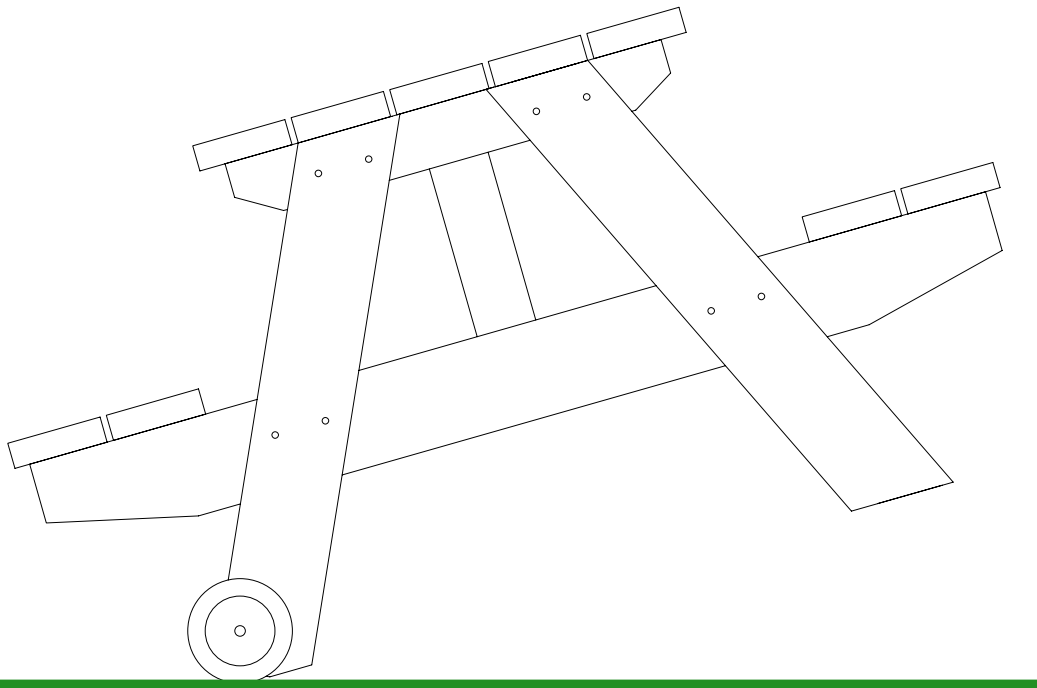

When raised like this, the wheels support the weight and picnic table may be rolled.

More Plans from: www.bobsplans.com



Router Table



Workbench



Dog House



Picnic Table



Octagon Table



6 Foot Bar



Corner Desk



Book Case



Mantel Clock



Redwood Planter



Wheelbarrow



Spoke Wheel



Panel Saw



Trellis



Wheelbarrow



Pocket Hole Jig



Tenoning Jig



Table Saw Sled



Drill Press Table