



# Product Catalog

## Variable Refrigerant Flow (VRF) Air Source Heat Pump and Heat Recovery Outdoor Units 4TVH\*/4TVR\*





## Introduction

Trane® VRF variable refrigerant systems are efficient, effective, reliable heating and cooling solutions you can trust. When VRF is the right solution for your application, Trane® will help you ensure it's the best solution. VRF is well suited for historic buildings without existing ductwork, as well as schools and mid-rise office buildings with multiple interior spaces and diverse occupancy rates.

Trane® VRF systems are designed for exceptional energy efficiency, offering industry leading performance up to 33 IEER and 32 SCHE. Trane® VRF utilizes inverter compressors (some model feature dual compressors) with vapor injection for improved performance and comfort.

Systems are available for both heat pump and simultaneous heating and cooling operation. Both feature individual zone control to provide individual occupant comfort. The simultaneous heating and cooling models offer the ability to heat and cool adjacent zones, intelligently exchanging energy between them through strategically located mode control units.

Indoor units are available in a wide variety of configurations and capacities, allowing architects the flexibility to satisfy almost any design requirement.

Trane® offers a complete line-up of controls to complete your VRF installation. These range from easy to use individual zone controls, to centralized systems for building monitoring and control, as well as optional BACnet® connectivity for centralized Trane® Tracer™ integration.

Best of all, your Trane® VRF™ system is supported by the Trane® nationwide network of sales and service offices.

## Copyright

This document and the information in it are the property of Trane, and may not be used or reproduced in whole or in part without written permission. Trane reserves the right to revise this publication at any time, and to make changes to its content without obligation to notify any person of such revision or change.

## Trademarks

All trademarks referenced in this document are the trademarks of their respective owners.

## Revision History

VRF-PRC008B-EN (17 February 2015)

- AHRI-1230 ratings updated and now include larger capacity systems previously not covered.
- Low ambient heating range expanded from -4°F to -13°F.



# Table of Contents

Introduction .....	2
Table of Contents .....	3
System Features .....	4
Model Number Descriptions .....	5
Products .....	6
Controls .....	7
Accessories .....	8
Product Specifications .....	10
Outdoor Units .....	10
Operation Limit - Outdoor Units .....	30
Defrosting Correction Factor .....	31
Electrical Wiring Diagrams - Outdoor Units .....	32
Sound Levels - Outdoor Units .....	38
NC Curves .....	38
Sound Power .....	40
NR Curves .....	40
Cycle Diagrams .....	42
Parts of Outdoor Unit (HP) .....	42
Parts of Outdoor Unit (HR) .....	45
Dimensional Drawings .....	48
Heat Pump/Heat Recovery .....	48



## System Features

- Individual modules are available as standard heat pump or simultaneous heating and cooling (heat recovery) configuration; units can be combined as double or triple modules for larger capacity requirements.
- 3rd generation compressor technology features all inverter compressors for superior efficiency and reliability
- Asymmetric scroll is designed to minimize frictional loss
- Dual inverter compressors (available in many models) are designed to equally share load for higher reliability
- Improved vapor injection system increases refrigerant flow rate up to 20% for superior heating performance
- Intercooler uses a plate heat exchanger for improved heating and cooling efficiency
- 8,400 RPM (maximum speed) compressor assures quick start cooling and heating performance
- Auto oil balancing eliminates the need for an oil balancing pipe
- Compressor inverter drives are liquid cooled for improved reliability
- Longer pipe lengths are the result of large oil storage capacity and low oil circulation rate
- Total harmonic distortion is reduced through adaptive sine wave control
- Refrigerant pump down and pump out facilitates maintenance and repair
- Automatic refrigerant balancing between indoor units optimize refrigerant distribution for better comfort and performance
- Optional quiet operation mode for reduced sound levels at night
- Auto snow blowing function removes accumulated snow when conditions require it
- Special hydrophilic heat exchanger coating minimizes frost build up on the outdoor coils and facilitates the defrost cycle.
- Anti-corrosion finish provides added protection in harsh environments
- Four and six port mode control units are light and compact. Distributed installation flexibility provides superior performance during simultaneous heating and cooling operation.
- Trane® VRF systems feature self-diagnosis, including system monitoring and error code reporting



# Model Number Descriptions

<b>4</b>	<b>T</b>	<b>V</b>	<b>R</b>	<b>0</b>	<b>0</b>	<b>9</b>	<b>6</b>	<b>B</b>	<b>3</b>	<b>0</b>	<b>0</b>	<b>N</b>	<b>B</b>
1	2	3	4	5	6	7	8	9	10	11	12	13	14

### Digit 1 – Refrigerant

4 = R-410A

### Digit 2 – Brand Name

T = Trane

### Digit 3 – System Type

V = Variable Refrigerant Flow

### Digit 4 – Functional Type Outdoor Unit

H = Heat Pump, DC Inverter (VRF)  
R = Heat Recovery (three pipe), DC Inverter

### Digit 5 – Special Application

0 = Standard

### Digit 6,7,8 – Nominal Capacity

**Important:** Btuh x1,000

072 = 72,000 Btuh  
096 = 96,000 Btuh  
120 = 120,000 Btuh  
144 = 144,000 Btuh

### Digit 9 – Major Development Sequence

B = Second Development Sequence

### Digit 10 – Electric Power Supply Characteristics

3 = 208–230/60/3  
4 = 460/60/3

### Digit 11 – Reserved for Future Use

0 = Not currently used

### Digit 12 – Reserved for Future Use

0 = Not currently used

### Digit 13 – Region of Sale

N = North America (UL or ETL)

### Digit 14 – Minor Design Sequence










B = Second Design Sequence

### System Combination Line-up

	Tons	4TVH/R0072B	4TVH/R0096B	4TVH/R0120B	4TVH/R0144B
Single Module	6	1			
	8		1		
	10			1	
	12				1
Double Module	14	1	1		
	16	1		1	
	18	1			1
	20			2	
	22			1	1
	24				2
Triple Module	26	1	1		1
	28	1		1	1
	30	1			2
	32			2	1
	34			1	2
	36				3

# Products

**Table 1. Application matrix**

Type		Capacity													
		7.5 MBh	9.0 MBh	9.5 MBh	12 MBh	18 MBh	20 MBh	24 MBh	30 MBh	36 MBh	42 MBh	48 MBh	60 MBh	76.8 MBh	96 MBh
Slim one way cassette		X		X	X										
Four way cassette			X		X	X		X	X	X		X			
Mini four way cassette				X	X	X	X								
Slim duct		X		X	X	X		X	X	X		X			
MSP duct						X		X	X	X		X			
HSP duct										X		X	X	X	
Ceiling						X		X							
High Wall		X		X	X	X	X	X							
Convertible AHU								X	X	X	X	X	X		

# Controls

**Table 2. Controls for VRF Products**

Family	Description	Model Number
Zone Controllers	VRF Wireless Remote Control	TVCTRLRDH00UT
	VRF Simple Wired Remote Control	TVCTRLWR001T
	VRF Wired Remote Control	TVCTRLWRWD01T
	VRF Duct Signal Receiver & Wire	TVCTRLRKA10N0
Centralized Control Systems	VRF Central On/Off Control	TVCTRLCMA202D
	VRF Touch Screen Control	TVCTRLCMA300T
	VRF Mode Select Switch	TVCTRLCMC2000
Integrated System Management	VRF System Controller	TVCTRLTMD00A0
	VRF Enterprise Management Software	TVCTRLTSTP3P00
	VRF Power Meter Interface Mod.	TVCTRLTIMB16A0
Building Management System Gateways	VRF System Controller + BACnet	TVCTRLTIMB17A0
	VRF System Controller + LonTalk™	TVCTRLTIMB18A0
Interface Modules	VRF External Contact Interface Module	TVCTRLTIMB14A0
	VRF Multi Function Control	TVCTRLTC210N00
	VRF MFC Enclosure	TVCTRLTC210BOX
	Required control box for 4TVM air handling unit	4TVCTRLAU001
Sensors	VRF Ext. Room Temp Sensor	TVCTRLRWTA000
	VRF Motion Sensor Mini 4Way	MOTIONSEN4TVB
Commissioning and Utility Kits	VRF Technician Utilities Tool	TVCTRLTMC0300
	VRF Auto-Commissioning Tool	TVCTRLTMC1000

# Accessories

**Table 3. Accessories for VRF Products**

Family	Description	Model Number
Refrigeration Joints	VRF Y-joint <51MBh	4YDK1509B0051A
	VRF Y-joint 51-138MBh	4YDK2512B0138A
	VRF Y-joint 138-160MBh	4YDK2812B0160A
	VRF Y-joint 160-240MBh	4YDK2815B0240A
	VRF Y-joint 240-336MBh	4YDK3419B0336A
	VRF Y-joint 336-468MBh	4YDK4119B0468A
	VRF Y-joint >468MBh	4YDK4422B0999A
	VRF Y-joint HR <80MBh	4YDK1500B0080A
	VRF Y-joint HR 80-240MBh	4YDK2500B0240A
	VRF Y-joint HR 240-468MBh	4YDK3100B0468A
	VRF Y-joint HR >468MBh	4YDK3800B0999A
	VRF T-joint >468MBh	4TDK3800B0999A
	VRF T-joint <468MBh	4TDK3819B0000A
	VRF T-joint HR <468MBh	4TDK3100B0000A
VRF T-joint HR >468MBh	4TDK4422B0999A	
Header Joints	VRF Header Joint 4Units<160MBh	4HJK2512B0159A
	VRF Header Joint 8Units 240MBh	4HJK3115B0241A
	VRF Header Joint 8Units<160MBh	4HJK3819B0998A
EEV Kits (For Floor/Ceiling and Selected High Wall Indoor Units)	VRF EEV Kit 1Unit 7-15.5MBh	4EEVEVA24SA000
	VRF EEV Kit 1Unit 17-31MBh	4EEVEVA32SA000
	VRF EEV 1x 7-15.5& 1x 17-31MBh	4EEVXDA24K132A
	VRF EEV Kit 2Unit 7-15.5MBh	4EEVXDA24K200A
	VRF EEV 2x 7-15.5& 1x 17-31MBh	4EEVXDA24K232A
	VRF EEV Kit 2Unit 17-31MBh	4EEVXDA32K200A
	VRF EEV 1x 7-15.5& 2x 17-31MBh	4EEVXDA32K224A
	VRF EEV Kit 3Unit 7-15.5MBh	4EEVXDA24K300A
VRF EEV Kit 3Unit 17-31MBh	4EEVXDA32K300A	
AHU Kits	VRF AHU Kit 24-30MBh	4EEVAKA40K1025
	VRF AHU Kit 48-60MBh	4EEVAKA40K1050
	VRF AHU Kit 72-90MBh	4EEVAKA64K1075
	VRF AHU Kit 96-112MBh	4EEVAKA64K1100



**Table 3. Accessories for VRF Products (continued)**

Family	Description	Model Number
Condensate Pumps	VRF Drain Pump High Wall and Floor/Ceiling	CONDPUMPAHWB01
	VRF Drain Pump Slim Duct	CONDPUMPXVLB01
	VRF Drain Pump MSP 18/24MBh	CONDPUMPXVMB01
	VRF Drain Pump MSP 30/36MBh	CONDPUMPXVMB02
	VRF Drain Pump MSP48/ HSP3648MBh	CONDPUMPXVDB01
	VRF Drain Pump HSP 76.8/96MBh	CONDPUMPXVHB01
Mode Control Units (for Simultaneous Heating and Cooling Applications)	VRF MCU Kit up to 4 IDU	4MCUCUY4NCE000
	VRF MCU Kit up to 6 IDU	4MCUCUY6NCE000
	VRF MCU Kit 2 IDU 36 MBh +	4MCUCUY2NCE000
Ball Valves	1/2" Ball Valve Flare	BVALVE12FLARE1
	1/4" Ball Valve Flare	BVALVE14FLARE1
	3/8" Ball Valve Flare	BVALVE38FLARE1
	5/8" Ball Valve Flare	BVALVE58FLARE1
Cassette Panels	VRF Cass. Panel Sliding 1Way	TVEPANPC1NUAET
	VRF Cass. Panel Slim 1Way	TVEPANPC1NUSET
	VRF Cass. Panel 4Way	TVEPANPC4NUSET
	VRF Cass. Panel Mini 4Way	TVEPANPC4SUSET
Pressure Differential Module (for high rise applications)	Pressure Diff Module 6/8/10 Ton	MXD-A12K2A
	Pressure Diff Module 12 Ton	MXD-A38K2A
Hail Guards	Hail Guard 4TVH/TVR0072B	TVRGARD001A
	Hail Guard 4TVH/TVR0096-0144B	TVRGARD002A
	Hail Guard 4TVH0036-0053B	TVRGARD003A



# Product Specifications

## Outdoor Units

**Table 4. 208-230V Heat Pump Single Modules**

Model Name			4TVH0072B300NB	4TVH0096B300NB	4TVH0120B300NB	4TVH0144B300NB					
Power Supply			208-230/60/3		208-230/60/3		208-230/60/3		208-230/60/3		
Performance	Nominal Tons		6.0		8.0		10.0		12.0		
	System Type		Ducted	Non-ducted	Ducted	Non-ducted	Ducted	Non-ducted	Ducted	Non-ducted	
	Capacity (Nominal) <sup>(a)</sup>	Cooling	Btuh	72,000	72,000	96,000	96,000	120,000	120,000	144,000	144,000
		Heating	Btuh	81,000	81,000	108,000	108,000	135,000	135,000	162,000	162,000
	Capacity (Rated) <sup>(b)</sup>	Cooling	Btuh	69,000	69,000	92,000	92,000	114,000	114,000	138,000	138,000
		High Temp Heating	Btuh	77,000	77,000	103,000	103,000	129,000	129,000	154,000	154,000
		Low Temp Heating	Btuh	51,000	51,000	67,000	67,000	84,000	84,000	100,000	100,000
	AHRI -1230 Efficiency Ratings <sup>(b)</sup>	EER	-	11.50	12.90	11.60	13.80	11.10	12.50	10.80	11.20
		IEER	-	22.50	33.00	23.00	31.00	21.80	26.70	21.10	24.50
		COP @ 47°F	-	3.46	4.15	3.60	4.23	3.43	3.97	3.54	3.64
COP @ 17°F		-	2.49	2.75	2.47	2.90	2.45	2.62	2.23	2.40	
	SCHE	-	-	-	-	-	-	-	-	-	
Power	MCA	A	28		37.8		43		52.6		
	MOP	A	35		50		50		70		
	SCCR	kA	-		-		-		5.0		
Compressor	Type (Qty.)	-	SSC SCROLL (1)		SSC SCROLL (2)		SSC SCROLL (2)		SSC SCROLL (2)		
	Model Name	-	DS-GB052FBVASG		DS-GB052FBVASG (2)		DS-GB052FBVASG (2)		DS-GB052FBVASG (2)		
	Output	kW each	4.96		4.96		4.96		4.96		
	Oil	Type	PVE		PVE		PVE		PVE		
Initial Charge	fl. oz.	77.8		155.5		155.5		155.5			
Fan	Type (Qty.)	-	Propeller (1)		Propeller (2)		Propeller (2)		Propeller (2)		
	Output (Each)	W	400		620		620		620		
	Airflow Rate	CFM	7,240		9,180		9,180		9,535		
	External Static Pressure	In. WG	0.31		0.31		0.31		0.31		
Piping Connections	Liquid Pipe	Ø inch	3/8" Braze		3/8" Braze		1/2" Braze		1/2" Braze		
	Gas Pipe	Ø inch	3/4" Braze		7/8" Braze		1 1/8" Braze		1 1/8" Braze		
	High Pressure Gas Pipe (For HR)	Ø inch	N/A		N/A		N/A		N/A		
	Installation Limits	Max Length <sup>(c)</sup>	ft.	656 (722)		656 (722)		656 (722)		656 (722)	
Max Height <sup>(d)</sup>		ft.	361 (131)		361 (131)		361 (131)		361 (131)		
Indoor Unit Connections	Number Of Connectable Indoor Units	-	12		16		20		25		
	Total Capacity	-	50 To 130% Of Total Outdoor Unit Capacity								
Refrigerant	Type	-	R-410A		R-410A		R-410A		R-410A		
	Factory Charge	lbs.	12.1		16.3		16.3		19.18		
Sound <sup>(e)</sup>	Sound Pressure	dB(A)	60.0		61.0		61.0		62.0		
	Sound Power	dB(A)	81		81		81		83		
External Dimensions	Net Weight	lbs.	425		624		624		657		
	Shipping Weight	lbs.	461		666		666		699		
	Net Dimensions (WXHXD)	inches	34.65 X 66.73 X 30.12		50.98 X 66.73 X 30.12		50.98 X 66.73 X 30.12		50.98 X 66.73 X 30.12		
	Shipping Dimensions (WXHXD)	inches	37.32 X 75.28 X 32.76		53.66 X 75.28 X 32.76		53.66 X 75.28 X 32.76		53.66 X 75.28 X 32.76		
Operating Temp Range	Cooling	°F	23 ~ 120		23 ~ 120		23 ~ 120		23 ~ 120		
	Heating	°F	-13 ~ 75		-13 ~ 75		-13 ~ 75		-13 ~ 75		

(a) Nominal capacity based on 25 ft. of equivalent refrigerant piping with 0 ft. level difference. Cooling: Indoor temperature 80°F DB, 67°F WB/Outdoor temperature 95°F DB, 75°F WB. Heating: Indoor temperature 70°F DB, 60°F WB/Outdoor temperature 47°F DB, 43°F WB

(b) Rated per AHRI-1230 Standard conditions.

(c) Actual length (equivalent length in parenthesis).

(d) If the outdoor unit is installed above the indoor units, the allowable height difference to the furthest indoor unit is 361 ft. (If the height difference exceeds 164 ft., request engineering support from Trane). If the outdoor unit is installed below the indoor units, the allowable height difference is 131 ft.

(e) Sound pressure was acquired in a dead room. Actual noise level may be different depending on installation conditions.

**Table 5. 208~230V Heat Pump Dual Modules I**

Model Name				4TVH0168B300NB	4TVH0192B300NB	4TVH0216B300NB			
				4TVH0072B300NB + 4TVH0096B300NB	4TVH0072B300NB + 4TVH0120B300NB	4TVH0072B300NB + 4TVH0144B300NB			
Power Supply				208-230/60/3		208-230/60/3			
Performance	Nominal Tons			14.0		16.0	18.0		
	System Type			Ducted	Non-Ducted	Ducted	Non-Ducted		
	Capacity (Nominal) <sup>(a)</sup>	Cooling	Btuh	168,000	168,000	192,000	192,000	216,000	216,000
		Heating	Btuh	189,000	189,000	216,000	216,000	243,000	243,000
	Capacity (Rated) <sup>(b)</sup>	Cooling	Btuh	160,000	160,000	184,000	183,000	206,000	206,000
		High Temp Heating	Btuh	180,000	180,000	206,000	206,000	230,000	230,000
		Low Temp Heating	Btuh	118,000	118,000	134,000	134,000	150,000	150,000
	AHRI -1230 Efficiency Ratings <sup>(b)</sup>	EER	-	11.40	12.10	10.90	11.40	10.60	10.80
		IEER	-	20.80	25.90	21.50	24.10	20.50	22.40
		COP @ 47°F	-	3.46	3.94	3.34	3.83	3.34	3.63
COP @ 17°F		-	2.43	2.65	2.42	2.59	2.31	2.52	
	SCHE	-	-	-	-	-	-	-	
Power	MCA	A	Each individual outdoor unit requires a separate electrical connection. Reference electrical data for each individual outdoor unit.						
	MOP	A							
	SCCR	kA							
Compressor	Type (Qty.)			SSC Scroll (3)		SSC Scroll (3)	SSC Scroll (3)		
	Model Name			DS-GB052FBVASG x 3		DS-GB052FBVASG x 3	DS-GB052FBVASG x 3		
	Output			kW each		4.96 x 3	4.96 x 3	4.96 x 3	
	Oil	Type	-	PVE		PVE	PVE		
Initial Charge		fl. oz.	233.3		233.3	233.3			
Fan	Type (Qty.)			Propeller (3)		Propeller (3)	Propeller (3)		
	Output (Each)			W		400 + 620 x 2	400 + 620 x 2		
	Airflow Rate			CFM		7,240 + 9,180	7,240 + 9,535		
	External Static Pressure			in. WG		0.31	0.31		
Piping Connections	Liquid Pipe			Ø inch		5/8" Braze	5/8" Braze	5/8" Braze	
	Gas Pipe			Ø inch		1 1/8" Braze	1 1/8" Braze	1 1/8" Braze	
	High Pressure Gas Pipe (For HR)			Ø inch		N/A	N/A	N/A	
	Installation Limits	Max Length <sup>(c)</sup>		ft.		656 (722)	656 (722)	656 (722)	
		Max Height <sup>(d)</sup>		ft.		361 (131)	361 (131)	361 (131)	
Indoor Unit Connections	Number Of Connectable Indoor Units			-		29	33	37	
	Total Capacity			-		50 to 130% of total outdoor unit capacity			
Refrigerant	Type			-		R-410A	R-410A	R-410A	
	Factory Charge			lbs.		28.4	28.4	31.3	
Sound <sup>(e)</sup>	Sound Pressure			dB(A)		-	-	-	
	Sound Power			dB(A)		-	-	-	
External Dimensions	Net Weight			lbs.		425 + 624	425 + 624	425 + 657	
	Shipping Weight			lbs.		461 + 666	461 + 666	461 + 699	
	Net Dimensions (WXHxD)			inches		34.65 x 66.73 x 30.12 + 50.98 x 66.73 x 30.12	34.65 x 66.73 x 30.12 + 50.98 x 66.73 x 30.12	34.65 x 66.73 x 30.12 + 50.98 x 66.73 x 30.12	
	Shipping Dimensions (WXHxD)			inches		37.32 x 75.28 x 32.76 + 53.66 x 75.28 x 32.76	37.32 x 75.28 x 32.76 + 53.66 x 75.28 x 32.76	37.32 x 75.28 x 32.76 + 53.66 x 75.28 x 32.76	
Operating Temp Range	Cooling			°F		23 ~ 120	23 ~ 120	23 ~ 120	
	Heating			°F		-13 ~ 75	-13 ~ 75	-13 ~ 75	

**Note:** Requires 4TDK3819B0000A outdoor unit T-joint connection

- (a) Nominal capacity based on 25 ft. of equivalent refrigerant piping with 0 ft. level difference; Cooling: Indoor temperature 80°F DB, 67°F WB/Outdoor temperature 95°F DB, 75°F WB. Heating: Indoor temperature 70°F DB, 60°F WB/Outdoor temperature 47°F DB, 43°F WB
- (b) Rated per AHRI-1230 Standard conditions.
- (c) Actual length (equivalent length in parenthesis).
- (d) If the outdoor unit is installed above the indoor units, the allowable height difference to the furthest indoor unit is 361 ft. If the outdoor unit is installed below the indoor units, the allowable height difference is 131 ft.
- (e) Sound pressure was acquired in a dead room. Actual noise level may be different depending on installation conditions.



## Product Specifications

**Table 6. 208~230V Heat Pump Dual Modules II**

Model Name			4TVH0240B300NB		4TVH0264B300NB		4TVH0288B300NB		
			2x 4TVH0120B300NB		4TVH0120B300NB + 4TVH0144B300NB		2x 4TVH0144B300NB		
Power Supply			208-230/60/3		208-230/60/3		208-230/60/3		
Performance	Nominal Tons		20.0		22.0		24.0		
	System Type		Ducted	Non-Ducted	Ducted	Non-Ducted	Ducted	Non-Ducted	
	Capacity (Nominal) <sup>(a)</sup>	Cooling	Btuh	240,000	240,000	264,000	264,000	288,000	288,000
		Heating	Btuh	270,000	270,000	297,000	297,000	324,000	324,000
	Capacity (Rated) <sup>(b)</sup>	Cooling	Btuh	228,000	228,000	252,000	252,000	276,000	276,000
		High Temp Heating	Btuh	258,000	258,000	282,000	282,000	308,000	308,000
		Low Temp Heating	Btuh	168,000	168,000	184,000	184,000	200,000	200,000
	AHRI -1230 Efficiency Ratings <sup>(b)</sup>	EER	-	10.60	11.10	10.10	10.50	10.00	9.50
		IEER	-	19.10	21.80	18.60	21.50	18.60	21.00
		COP @ 47°F	-	3.24	3.65	3.25	3.45	3.25	3.26
COP @ 17°F		-	2.40	2.54	2.26	2.41	2.12	2.29	
	SCHE	-	-	-	-	-	-	-	
Power	MCA	A	28		37.8		43		
	MOP	A	35		50		50		
	SCCR	kA	-		-		-		
Compressor	Type (Qty.)		SSC Scroll (1)		SSC Scroll (2)		SSC Scroll (2)		
	Model Name		DS-GB052FBVASG		DS-GB052FBVASG x 2		DS-GB052FBVASG x 2		
	Output		kW each		4.96 x 4		4.96 x 4		
	Oil	Type	-	PVE		PVE		PVE	
Initial Charge		fl. oz.	311.1		311.1		311.1		
Fan	Type (Qty.)		Propeller (4)		Propeller (4)		Propeller (4)		
	Output (Each)		W		620 x 4		620 x 4		
	Airflow Rate		CFM		9180 x 2		9,180 + 9,535		
	External Static Pressure		in. WG		0.31		0.31		
Piping Connections	Liquid Pipe		Ø inch		5/8" Braze		3/4" Braze		
	Gas Pipe		Ø inch		1 1/8" Braze		1 3/8" Braze		
	High Pressure Gas Pipe (For HR)		Ø inch		N/A		N/A		
	Installation Limits	Max Length <sup>(c)</sup>	ft.	656 (722)		656 (722)		656 (722)	
		Max Height <sup>(d)</sup>	ft.	361 (131)		361 (131)		361 (131)	
Indoor Unit Connections	Number Of Connectable Indoor Units		-		41		45		
	Total Capacity		-		50 to 130% of total outdoor unit cooling capacity				
Refrigerant	Type		-		R410A		R410A		
	Factory Charge		lbs.		32.6		35.5		
Sound <sup>(e)</sup>	Sound Pressure		dB(A)		-		-		
	Sound Power		dB(A)		-		-		
External Dimensions	Net Weight		lbs.		624 x 2		624 + 657		
	Shipping Weight		lbs.		699 x 2		665 + 699		
	Net Dimensions (WXHXD)		inches		(50.98 x 66.73 x 30.12) x 2		(50.98 x 66.73 x 30.12) x 2		
	Shipping Dimensions (WXHXD)		inches		(53.66 x 75.28 x 32.76) x 2		(53.66 x 75.28 x 32.76) x 2		
Operating Temp Range	Cooling		°F		23 ~ 120		23 ~ 120		
	Heating		°F		-13 ~ 75		-13 ~ 75		

**Note:** Requires 4TDK3819B0000A outdoor unit T-joint connection

- (a) Nominal capacity based on 25 ft. of equivalent refrigerant piping with 0 ft. level difference. Cooling: Indoor temperature 80°F DB, 67°F WB/Outdoor temperature 95°F DB, 75°F WB. Heating: Indoor temperature 70°F DB, 60°F WB/Outdoor temperature 47°F DB, 43°F WB.  
 (b) Rated per AHRI-1230 Standard conditions.  
 (c) Actual length (equivalent length in parenthesis).  
 (d) If the outdoor unit is installed above the indoor units, the allowable height difference to the furthest indoor unit is 361 ft. If the outdoor unit is installed below the indoor units, the allowable height difference is 131 ft.  
 (e) Sound pressure was acquired in a dead room. Actual noise level may be different depending on installation conditions.

**Table 7. 208-230V Heat Pump Triple Modules I**

Model Name			4TVH0312B300NB	4TVH0336B300NB	4TVH0360B300NB	
			4TVH0072B300NB + 4TVH0096B300NB + 4TVH0144B300NB	4TVH0072B300NB + 4TVH0120B300NB + 4TVH0144B300NB	4TVH0072B300NB + 2x 4TVH0144B300NB	
Power Supply			208-230/60/3		208-230/60/3	
Performance	Nominal Tons	26.0		28.0		
	System Type	Ducted	Non-Ducted	Ducted	Non-Ducted	
	Capacity (Nominal) <sup>(a)</sup>	Cooling	Btuh	312,000	312,000	336,000
		Heating	Btuh	351,000	351,000	378,000
	Capacity (Rated) <sup>(b)</sup>	Cooling	Btuh	298,000	298,000	320,000
		High Temp Heating	Btuh	334,000	334,000	360,000
		Low Temp Heating	Btuh	218,000	218,000	234,000
	AHRI -1230 Efficiency Ratings <sup>2</sup>	EER	-	10.30	10.50	10.00
		IEER	-	18.30	21.20	17.10
		COP @ 47°F	-	3.20	3.38	3.20
COP @ 17°F		-	2.25	2.54	2.21	
	SCHE	-	-	-	-	
Power	MCA	A	Each individual outdoor unit requires a separate electrical connection. Reference electrical data for each individual outdoor unit.			
	MOP	A				
	SCCR	kA				
Compressor	Type (Qty.)	-	SSC Scroll (5)	SSC Scroll (5)	SSC Scroll (5)	
	Model Name	-	DS-GB052FBVASG (5)	DS-GB052FBVASG (5)	DS-GB052FBVASG (5)	
	Output	kW each	4.96 x 5	4.96 x 5	4.96 x 5	
	Oil	Type	-	PVE	PVE	PVE
Initial Charge		fl. oz.	388.9	388.9	388.9	
Fan	Type (Qty.)	-	Propeller (5)	Propeller (5)	Propeller (5)	
	Output (Each)	W	400 + 620 x 4	400 + 620 x 4	400 + 620 x 4	
	Airflow Rate	CFM	7,240 + 9,180 + 9,535	7,240 + 9,180 + 9,535	7,240 + (9,535 x2)	
	External Static Pressure	in. WG	0.31	0.31	0.31	
Piping Connections	Liquid Pipe	Ø inch	3/4" Braze	3/4" Braze	3/4" Braze	
	Gas Pipe	Ø inch	1 3/8" Braze	1 3/8" Braze	1 5/8" Braze	
	High Pressure Gas Pipe (For Hr)	Ø inch	N/A	N/A	N/A	
	Installation Limits	Max Length <sup>(c)</sup>	ft.	656 (722)	656 (722)	656 (722)
Max Height <sup>(d)</sup>		ft.	361 (131)	361 (131)	361 (131)	
Indoor Unit Connections	Number Of Connectable Indoor Units	-	54	58	62	
	Total Capacity	-	50 to 130% of total outdoor unit capacity			
Refrigerant	Type	-	R410A	R410A	R410A	
	Factory Charge	lbs.	47.6	47.6	50.5	
Sound <sup>(e)</sup>	Sound Pressure	dB(A)	-	-	-	
	Sound Power	dB(A)	-	-	-	
External Dimensions	Net Weight	lbs.	425 + 624 + 657	425 + 624 + 657	425 + (657 x2)	
	Shipping Weight	lbs.	461 + 666 + 699	461 + 666 + 699	461 + (699 x2)	
	Net Dimensions (WxHxD)	inches	34.65 x 66.73 x 30.12 + (50.98 x 66.73 x 30.12) x2	34.65 x 66.73 x 30.12 + (50.98 x 66.73 x 30.12) x2	34.65 x 66.73 x 30.12 + (50.98 x 66.73 x 30.12) x2	
		inches	37.32 x 75.28 x 32.76 + (53.66 x 75.28 x 32.76) x2	37.32 x 75.28 x 32.76 + (53.66 x 75.28 x 32.76) x2	37.32 x 75.28 x 32.76 + (53.66 x 75.28 x 32.76) x2	
Operating Temp Range	Cooling	°F	23 ~ 120	23 ~ 120	23 ~ 120	
	Heating	°F	-13 ~ 75	-13 ~ 75	-13 ~ 75	

**Note:** Requires two 4TDK3819B0000A outdoor unit T-joint connections

- (a) Nominal capacity based on 25 ft. of equivalent refrigerant piping with 0 ft. level difference. Cooling: Indoor temperature 80°F DB, 67°F WB/Outdoor temperature 95°F DB, 75°F WB. Heating: Indoor temperature 70°F DB, 60°F WB/Outdoor temperature 47°F DB, 43°F WB.
- (b) Rated per AHRI-1230 Standard conditions (published ratings apply to systems ≤ 300,000 Btuh).
- (c) Actual length (equivalent length in parenthesis).
- (d) If the outdoor unit is installed above the indoor units, the allowable height difference to the furthest indoor unit is 361 ft. If the outdoor unit is installed below the indoor units, the allowable height difference is 131 ft..
- (e) Sound pressure was acquired in a dead room. Actual noise level may be different depending on installation conditions.



## Product Specifications

**Table 8. 208-230V Heat Pump Triple Modules II**

Model Name			4TVH0384B300NB	4TVH0408B300NB	4TVH0432B300NB				
			2x 4TVH0120B300NB + 4TVH0144B300NB	4TVH0120B300NB + 2x 4TVH0144B300NB	3x 4TVH0144B300NB				
Power Supply			208-230/60/3	208-230/60/3	208-230/60/3				
Performance	Nominal Tons		32.0		34.0	36.0			
	System Type		Ducted	Non-Ducted	Ducted	Non-Ducted			
	Capacity (Nominal) <sup>(a)</sup>	Cooling	Btuh	384,000	384,000	408,000	408,000	432,000	432,000
		Heating	Btuh	432,000	432,000	459,000	459,000	486,000	486,000
	Capacity (Rated) <sup>(b)</sup>	Cooling	Btuh	366,000	366,000	390,000	390,000	415,000	415,000
		High Temp Heating	Btuh	410,000	410,000	435,000	435,000	460,000	460,000
		Low Temp Heating	Btuh	268,000	268,000	284,000	284,000	300,000	300,000
	AHRI - 1230 Efficiency Ratings <sup>(b)</sup>	EER	-	9.50	9.50	9.50	9.50	9.50	9.50
		IEER	-	16.50	19.50	16.40	19.10	16.30	19.10
		COP @ 47°F	-	3.20	3.20	3.20	3.20	3.20	3.20
COP @ 17°F		-	2.05	2.10	2.05	2.05	2.05	2.05	
	SCHE	-	-	-	-	-	-	-	
Power	MCA	A	Each individual outdoor unit requires a separate electrical connection. Reference electrical data for each individual outdoor unit.						
	MOP	A							
	SCCR	kA							
Compressor	Type (Qty.)		SSC Scroll (6)		SSC Scroll (6)	SSC Scroll (6)			
	Model Name		DS-GB052FBVASG (6)		DS-GB052FBVASG (6)	DS-GB052FBVASG (6)			
	Output		kW each		4.96 x 6	4.96 x 6	4.96 x 6		
	Oil	Type	-		PVE	PVE	PVE		
Initial Charge		fl. oz.	466.6		466.6	466.6			
Fan	Type (Qty.)		Propeller (6)		Propeller (6)	Propeller (6)			
	Output (Each)		W		620 x 6	620 x 6	620 x 6		
	Airflow Rate		CFM		(9,180 x 2) + 9535	9,180 + (2x 9,535)	9535 x 3		
	External Static Pressure		in. WG		0.31	0.31	0.31		
Piping Connections	Liquid Pipe		Ø inch		3/4" Braze	3/4" Braze	3/4" Braze		
	Gas Pipe		Ø inch		1 5/8" Braze	1 5/8" Braze	1 5/8" Braze		
	High Pressure Gas Pipe (For Hr)		Ø inch		N/A	N/A	N/A		
	Installation Limits	Max Length <sup>(c)</sup>	ft.	656 (722)		656 (722)	656 (722)		
Max Height <sup>(d)</sup>		ft.	361 (131)		361 (131)	361 (131)			
Indoor Unit Connections	Number Of Connectable Indoor Units		-		64	64	64		
	Total Capacity		-		50 to 130% of total outdoor unit capacity				
Refrigerant	Type		-		R410A	R410A	R410A		
	Factory Charge		lbs.		51.8	54.7	57.5		
Sound <sup>(e)</sup>	Sound Pressure		dB(A)		-	-	-		
	Sound Power		dB(A)		-	-	-		
External Dimensions	Net Weight		lbs.		(624 x 2) + 657	624 + (657 x 2)	657 x 3		
	Shipping Weight		lbs.		(666 x 2) + 699	666 + (699 x 2)	699 x 3		
	Net Dimensions (WxHxD)		inches		(50.98 x 66.73 x 30.12) x 3	(50.98 x 66.73 x 30.12) x 3	(50.98 x 66.73 x 30.12) x 3		
Shipping Dimensions (WxHxD)		inches		(53.66 x 75.28 x 32.76) x 3	(53.66 x 75.28 x 32.76) x 3	(53.66 x 75.28 x 32.76) x 3			
Operating Temp Range	Cooling		°F		23 ~ 120	23 ~ 120	23 ~ 120		
	Heating		°F		-13 ~ 75	-13 ~ 75	-13 ~ 75		

**Note:** Requires two 4TDK3819B0000A outdoor unit T-joint connections

- (a) Nominal capacity based on 25 ft. of equivalent refrigerant piping with 0 ft. level difference. Cooling: Indoor temperature 80°F DB, 67°F WB/Outdoor temperature 95°F DB, 75°F WB. Heating: Indoor temperature 70°F DB, 60°F WB/Outdoor temperature 47°F DB, 43°F WB.  
 (b) Rated per AHRI-1230 Standard conditions (published ratings apply to systems ≤ 300,000 Btuh).  
 (c) Actual length (equivalent length in parenthesis).  
 (d) If the outdoor unit is installed above the indoor units, the allowable height difference to the furthest indoor unit is 361 ft. If the outdoor unit is installed below the indoor units, the allowable height difference is 131 ft.  
 (e) Sound pressure was acquired in a dead room. Actual noise level may be different depending on installation conditions

**Table 9. 208-230V Heat Recovery Single Modules**

Model Name			4TVR0072B300NB	4TVR0096B300NB	4TVR0120B300NB	4TVR0144B300NB					
Power Supply			208-230/60/3		208-230/60/3		208-230/60/3		208-230/60/3		
Nominal Tons			6.0		8.0		10.0		12.0		
System Type			Ducted	Non-Ducted	Ducted	Non-Ducted	Ducted	Non-Ducted	Ducted	Non-Ducted	
Performance	Capacity (Nominal) <sup>(a)</sup>	Cooling	Btuh	72,000	72,000	96,000	96,000	120,000	120,000	144,000	144,000
		Heating	Btuh	81,000	81,000	108,000	108,000	135,000	135,000	162,000	162,000
	Capacity (Rated) <sup>(b)</sup>	Cooling	Btuh	69,000	69,000	92,000	92,000	114,000	114,000	138,000	138,000
		High Temp Heating	Btuh	77,000	77,000	103,000	103,000	129,000	129,000	154,000	154,000
		Low Temp Heating	Btuh	51,000	51,000	67,000	67,000	84,000	84,000	100,000	100,000
	AHRI -1230 Efficiency Ratings <sup>(b)</sup>	EER	-	11.50	12.90	11.60	13.80	11.10	12.50	10.80	11.20
		IEER	-	22.50	33.00	23.00	31.00	21.80	26.70	21.10	24.50
		COP @ 47°F	-	3.46	4.15	3.60	4.23	3.43	3.97	3.54	3.64
		COP @ 17°F	-	2.49	2.75	2.47	2.90	2.45	2.62	2.23	2.40
	SCHE	-	26.00	28.00	26.50	32.00	25.50	31.00	25.00	27.50	
Power	MCA	A	28		37.8		43		52.6		
	MOP	A	35		50		50		70		
	SCCR	kA	-		-		-		5.0		
Compressor	Type (Qty.)	-	SSC Scroll (1)		SSC Scroll (2)		SSC Scroll (2)		SSC Scroll (2)		
	Model Name	-	DS-GB052FBVASG		DS-GB052FBVASG x 2		DS-GB052FBVASG x 2		DS-GB052FBVASG x 2		
	Output	kW each	4.96		4.96 x 2		4.96 x 2		4.96 x 2		
	Oil	Type	-	PVE		PVE		PVE		PVE	
Initial Charge		fl. oz.	77.8		155.5		155.5		155.5		
Fan	Type (Qty.)	-	Propeller (1)		Propeller (2)		Propeller (2)		Propeller (2)		
	Output (Each)	W	400		620		620		620		
	Airflow Rate	CFM	7,240		9,180		9,180		9,535		
	External Static Pressure	in. WG	0.31		0.31		0.31		0.31		
Piping Connections	Liquid Pipe	Ø inch	3/8" Braze		3/8" Braze		1/2" Braze		1/2" Braze		
	Gas Pipe	Ø inch	3/4" Braze		7/8" Braze		1 1/8" Braze		1 1/8" Braze		
	High Pressure Gas Pipe (For Hr)	Ø inch	5/8" Braze		3/4" Braze		7/8" Braze		7/8" Braze		
	Installation Limits	Max Length <sup>(c)</sup>	ft.	656 (722)		656 (722)		656 (722)		656 (722)	
Max Height <sup>(d)</sup>		ft.	361 (131)		361 (131)		361 (131)		361 (131)		
Indoor Unit Connections	Number Of Connectable Indoor Units	-	12		16		20		25		
	Total Capacity	-	50 to 130% of total outdoor unit capacity								
Refrigerant	Type	-	R410A		R410A		R410A		R410A		
	Factory Charge	lbs.	12.1		16.3		16.3		19.18		
Sound <sup>(e)</sup>	Sound Pressure	dB(A)	60.0		61.0		61.0		62.0		
	Sound Power	dB(A)	81		81		81		83		
External Dimensions	Net Weight	lbs.	430		637		637		672		
	Shipping Weight	lbs.	465		679		679		714		
	Net Dimensions (WxHxD)	inches	34.65 x 66.73 x 30.12		50.98 x 66.73 x 30.12		50.98 x 66.73 x 30.12		50.98 x 66.73 x 30.12		
	Shipping Dimensions (WxHxD)	inches	37.32 x 75.28 x 32.76		53.66 x 75.28 x 32.76		53.66 x 75.28 x 32.76		53.66 x 75.28 x 32.76		
Operating Temp Range	Cooling <sup>(f)</sup>	°F	5 ~ 120		5 ~ 120		5 ~ 120		5 ~ 120		
	Heating	°F	-13 ~ 75		-13 ~ 75		-13 ~ 75		-13 ~ 75		

(a) Nominal capacity based on 25 ft. of equivalent refrigerant piping with 0 ft. level difference. Cooling: Indoor temperature 80°F DB, 67°F WB/Outdoor temperature 95°F DB, 75°F WB. Heating: Indoor temperature 70°F DB, 60°F WB/Outdoor temperature 47°F DB, 43°F WB.

(b) Rated per AHRI-1230 Standard conditions.

(c) Actual length (equivalent length in parenthesis).

(d) If the outdoor unit is installed above the indoor units, the allowable height difference to the furthest indoor unit is 361 ft. If the outdoor unit is installed below the indoor units, the allowable height difference is 131 ft.

(e) Sound pressure was acquired in a dead room. Actual noise level may be different depending on installation conditions.

(f) Cooling operation between 23° F and 5° F requires mixed mode condition (at least 50% of the indoor units must be in heating mode).



## Product Specifications

**Table 10. 208-230V Heat Recovery Dual Modules I**

Model Name			4TVR0168B300NB	4TVR0192B300NB	4TVR0216B300NB				
			4TVR0072B300NB + 4TVR0096B300NB	4TVR0072B300NB + 4TVR0120B300NB	4TVR0072B300NB + 4TVR0144B300NB				
Power Supply			208-230/60/3		208-230/60/3				
Performance	Nominal Tons		14.0		16.0	18.0			
	System Type		Ducted	Non-Ducted	Ducted	Non-Ducted			
	Capacity (Nominal) <sup>(a)</sup>	Cooling	Btuh	168,000	168,000	192,000	192,000	216,000	216,000
		Heating	Btuh	189,000	189,000	216,000	216,000	243,000	243,000
		Cooling	Btuh	160,000	160,000	184,000	184,000	206,000	206,000
	Capacity (Rated) <sup>(b)</sup>	High Temp Heating	Btuh	180,000	180,000	206,000	206,000	230,000	230,000
		Low Temp Heating	Btuh	118,000	118,000	134,000	134,000	150,000	150,000
		AHRI -1230 Efficiency Ratings <sup>(b)</sup>	EER	-	11.40	12.10	10.90	11.40	10.60
		IEER	-	20.80	25.90	21.50	24.10	20.50	22.40
		COP @ 47°F	-	3.46	3.94	3.34	3.83	3.34	3.63
	COP @ 17°F	-	2.43	2.65	2.42	2.59	2.31	2.52	
	SCHE	-	23.50	27.00	23.50	26.50	23.00	25.50	
Power	MCA	A	Each individual outdoor unit requires a separate electrical connection. Reference electrical data for each individual outdoor unit.						
	MOP	A							
	SCCR	kA							
Compressor	Type (Qty.)	-	SSC Scroll (3)	SSC Scroll (3)	SSC Scroll (3)				
	Model Name	-	DS-GB052FBVASG x 3	DS-GB052FBVASG x 3	DS-GB052FBVASG x 3				
	Output	kW each	4.96 x 3	4.96 x 3	4.96 x 3				
	Oil	Type	-	PVE	PVE	PVE			
		Initial Charge	fl. oz.	233.3	233.3	233.3			
Fan	Type (Qty.)	-	Propeller (3)	Propeller (3)	Propeller (3)				
	Output (Each)	W	400 + 620 x 2	400 + 620 x 2	400 + 620 x 2				
	Airflow Rate	CFM	7,240 + 9,180	7,240 + 9,180	7,240 + 9,535				
	External Static Pressure	in. WG	0.31	0.31	0.31				
	Piping Connections	Liquid Pipe	Ø inch	5/8" Braze	5/8" Braze	5/8" Braze			
Gas Pipe		Ø inch	1 1/8" Braze	1 1/8" Braze	1 1/8" Braze				
High Pressure Gas Pipe (For Hr)		Ø inch	7/8" Braze	1 1/8" Braze	1 1/8" Braze				
Installation Limits		Max Length <sup>(c)</sup>	ft.	656 (722)	656 (722)	656 (722)			
		Max Height <sup>(d)</sup>	ft.	361 (131)	361 (131)	361 (131)			
Indoor Unit Connections	Number Of Connectable Indoor Units	-	29	33	37				
	Total Capacity	-	50 to 130% of total outdoor unit capacity						
Refrigerant	Type	-	R410A	R410A	R410A				
	Factory Charge	lbs.	28.4	28.4	31.3				
Sound <sup>(e)</sup>	Sound Pressure	dB(A)	-	-	-				
	Sound Power	dB(A)	-	-	-				
External Dimensions	Net Weight	lbs.	430 + 637	430 + 637	430 + 672				
	Shipping Weight	lbs.	465 + 479	465 + 479	465 + 714				
	Net Dimensions (WxHxD)	inches	34.65 x 66.73 x 30.12 + 50.98 x 66.73 x 30.12	34.65 x 66.73 x 30.12 + 50.98 x 66.73 x 30.12	34.65 x 66.73 x 30.12 + 50.98 x 66.73 x 30.12				
	Shipping Dimensions (WxHxD)	inches	37.32 x 75.28 x 32.76 + 53.66 x 75.28 x 32.76	37.32 x 75.28 x 32.76 + 53.66 x 75.28 x 32.76	37.32 x 75.28 x 32.76 + 53.66 x 75.28 x 32.76				
Operating Temp Range	Cooling <sup>(f)</sup>	°F	5 – 120	5 – 120	5 – 120				
	Heating	°F	-13 – 75	-13 – 75	-13 – 75				

**Note:** Requires 4TDK3819B0000A and 4TDK3100B0000A outdoor unit T-joint connections

- (a) Nominal capacity based on 25 ft. of equivalent refrigerant piping with 0 ft. level difference. Cooling: Indoor temperature 80°F DB, 67°F WB/Outdoor temperature 95°F DB, 75°F WB. Heating: Indoor temperature 70°F DB, 60°F WB/Outdoor temperature 47°F DB, 43°F WB.
- (b) Rated per AHRI-1230 Standard conditions.
- (c) Actual length (equivalent length in parenthesis).
- (d) If the outdoor unit is installed above the indoor units, the allowable height difference to the furthest indoor unit is 361 ft. If the outdoor unit is installed below the indoor units, the allowable height difference is 131 ft.
- (e) Sound pressure was acquired in a dead room. Actual noise level may be different depending on installation conditions.
- (f) Cooling operation between 23° F and 5° F requires mixed mode condition (at least 50% of the indoor units must be in heating mode).



**Table 11. 208~230V Heat Recovery Dual Modules II**

Model Name			4TVR0240B300NB	4TVR0264B300NB	4TVR0288B300NB	
			2x 4TVR0120B300NB	4TVR0120B300NB + 4TVR0144B300NB	2x 4TVR0144B300NB	
Power Supply			208-230/60/3		208-230/60/3	
Performance	Nominal Tons		20.0		22.0	
	System Type		Ducted	Non-Ducted	Ducted	
	Capacity (Nominal) <sup>(a)</sup>	Cooling	Btuh	240,000	240,000	264,000
		Heating	Btuh	270,000	270,000	297,000
	Capacity (Rated) <sup>(b)</sup>	Cooling	Btuh	228,000	228,000	252,000
		High Temp Heating	Btuh	258,000	258,000	282,000
		Low Temp Heating	Btuh	168,000	168,000	184,000
	AHRI -1230 Efficiency Ratings <sup>(b)</sup>	EER	-	10.60	11.10	10.10
		I EER	-	19.10	21.80	18.60
		COP @ 47°F	-	3.24	3.65	3.25
COP @ 17°F		-	2.40	2.54	2.26	
	SCHE	-	22.50	25.50	22.00	
Power	MCA	A	Each individual outdoor unit requires a separate electrical connection. Reference electrical data for each individual outdoor unit.			
	MOP	A				
	SCCR	kA				
Compressor	Type (Qty.)	-	SSC Scroll (4)	SSC Scroll (4)	SSC Scroll (4)	
	Model Name	-	DS-GB052FBVASG x 4	DS-GB052FBVASG x 4	DS-GB052FBVASG x 4	
	Output	kW each	4.96 x 4	4.96 x 4	4.96 x 4	
	Oil	Type	-	PVE	PVE	PVE
Initial Charge		fl. oz.	311.1	311.1	311.1	
Fan	Type (Qty.)	-	Propeller (4)	Propeller (4)	Propeller (4)	
	Output (Each)	W	620 x 4	620 x 4	620 x 4	
	Airflow Rate	CFM	9180 x 2	9,180 + 9,535	9535 x 2	
	External Static Pressure	in. WG	0.31	0.31	0.31	
Piping Connections	Liquid Pipe	Ø inch	5/8" Braze	3/4" Braze	3/4" Braze	
	Gas Pipe	Ø inch	1 1/8" Braze	1 3/8" Braze	1 3/8" Braze	
	High Pressure Gas Pipe (For Hr)	Ø inch	1 1/8" Braze	1 1/8" Braze	1 1/8" Braze	
	Installation Limits	Max Length <sup>(c)</sup>	ft.	656 (722)	656 (722)	656 (722)
Max Height <sup>(d)</sup>		ft.	361 (131)	361 (131)	361 (131)	
Indoor Unit Connections	Number Of Connectable Indoor Units	-	41	45	49	
	Total Capacity	-	50 to 130% of total outdoor unit capacity			
Refrigerant	Type	-	R-410A	R410A	R410A	
	Factory Charge	lbs.	32.6	32.6	35.5	
Sound <sup>(e)</sup>	Sound Pressure	dB(A)	-	-	-	
	Sound Power	dB(A)	-	-	-	
External Dimensions	Net Weight	lbs.	637 x 2	637 x 2	637 + 672	
	Shipping Weight	lbs.	714 x 2	679 x 2	679 + 714	
	Net Dimensions (WxHxD)	inches	(50.98 x 66.73 x 30.12) x 2	(50.98 x 66.73 x 30.12) x 2	(50.98 x 66.73 x 30.12) x 2	
	Shipping Dimensions (WxHxD)	inches	(53.66 x 75.28 x 32.76) x 2	(53.66 x 75.28 x 32.76) x 2	(53.66 x 75.28 x 32.76) x 2	
Operating Temp Range	Cooling <sup>(f)</sup>	°F	23 ~ 120	5 ~ 120	5 ~ 120	
	Heating	°F	-4 ~ 75	-13 ~ 75	-13 ~ 75	

**Note:** Requires 4TDK3819B0000A and 4TDK3100B0000A outdoor unit T-joint connections

- (a) Nominal capacity based on 25 ft. of equivalent refrigerant piping with 0 ft. level difference. Cooling: Indoor temperature 80°F DB, 67°F WB/Outdoor temperature 95°F DB, 75°F WB. Heating: Indoor temperature 70°F DB, 60°F WB/Outdoor temperature 47°F DB, 43°F WB.
- (b) Rated per AHRI-1230 Standard conditions.
- (c) Actual length (equivalent length in parenthesis).
- (d) If the outdoor unit is installed above the indoor units, the allowable height difference to the furthest indoor unit is 361 ft. If the outdoor unit is installed below the indoor units, the allowable height difference is 131 ft.
- (e) Sound pressure was acquired in a dead room. Actual noise level may be different depending on installation conditions.
- (f) Cooling operation between 23° F and 5° F requires mixed mode condition (at least 50% of the indoor units must be in heating mode).



## Product Specifications

**Table 12. 208-230V Heat Recovery Triple Modules I**

Model Name			4TVR0312B300NB	4TVR0336B300NB	4TVR0360B300NB				
			4TVR0072B300NB + 4TVR0096B300NB + 4TVR0144B300NB	4TVR0072B300NB + 4TVR0120B300NB + 4TVR0144B300NB	4TVR0072B300NB + 2x 4TVR0144B300NB				
Power Supply			208-230/60/3		208-230/60/3				
Nominal Tons			26.0		30.0				
System Type			Ducted	Non-Ducted	Ducted				
Performance	Capacity (Nominal) <sup>(a)</sup>	Cooling	Btuh	312,000	312,000	336,000	336,000	360,000	360,000
		Heating	Btuh	351,000	351,000	378,000	378,000	405,000	405,000
	Capacity (Rated) <sup>(b)</sup>	Cooling	Btuh	298,000	298,000	320,000	320,000	344,000	344,000
		High Temp Heating	Btuh	334,000	334,000	360,000	360,000	386,000	386,000
		Low Temp Heating	Btuh	218,000	218,000	234,000	234,000	250,000	250,000
	AHRI -1230 Efficiency Ratings <sup>(b)</sup>	EER	-	10.30	10.50	10.00	10.20	9.80	9.80
		IEER	-	18.30	21.20	17.10	20.50	16.60	20.00
		COP @ 47°F	-	3.20	3.38	3.20	3.27	3.20	3.22
COP @ 17°F		-	2.25	2.54	2.21	2.39	2.11	2.31	
	SCHE	-	20.50	23.50	20.50	23.10	20.00	22.40	
Power	MCA	A	Each individual outdoor unit requires a separate electrical connection. Reference electrical data for each individual outdoor unit.						
	MOP	A							
	SCCR	kA							
Compressor	Type (Qty.)	-	SSC Scroll (5)		SSC Scroll (5)		SSC Scroll (5)		
	Model Name	-	DS-GB052FBVASG x 5		DS-GB052FBVASG x 5		DS-GB052FBVASG x 5		
	Output	kW each	4.96 x 5		4.96 x 5		4.96 x 5		
	Oil	Type	-	PVE		PVE		PVE	
Initial Charge		fl. oz.	388.9		388.9		388.9		
Fan	Type (Qty.)	-	Propeller (5)		Propeller (5)		Propeller (5)		
	Output (Each)	W	400 + 620 x 4		400 + 620 x 4		400 + 620 x 4		
	Airflow Rate	CFM	7,240 + 9,180 + 9,535		7,240 + 9,180 + 9,535		7,240 + (9,535 x2)		
	External Static Pressure	in. WG	0.31		0.31		0.31		
Piping Connections	Liquid Pipe	Ø inch	3/4" Braze		3/4" Braze		3/4" Braze		
	Gas Pipe	Ø inch	1 3/8" Braze		1 3/8" Braze		1 5/8" Braze		
	High Pressure Gas Pipe (For Hr)	Ø inch	1 1/8" Braze		1 1/8" Braze		1 3/8" Braze		
	Installation Limits	Max Length <sup>(c)</sup>	ft.	656 (722)		656 (722)		656 (722)	
Max Height <sup>(d)</sup>		ft.	361 (131)		361 (131)		361 (131)		
Indoor Unit Connections	Number Of Connectable Indoor Units	-	54		58		62		
	Total Capacity	-	50 to 130% of total outdoor unit capacity						
Refrigerant	Type	-	R410A		R410A		R410A		
	Factory Charge	lbs.	47.6		47.6		50.5		
Sound <sup>(e)</sup>	Sound Pressure	dB(A)	-		-		-		
	Sound Power	dB(A)	-		-		-		
External Dimensions	Net Weight	lbs.	430 + 637 + 672		430 + 637 + 672		430 + (672 x 2)		
	Shipping Weight	lbs.	465 + 679 + 714		465 + 679 + 714		465 + (714 x 2)		
	Net Dimensions (WxHxD)	inches	34.65 x 66.73 x 30.12 + (50.98 x 66.73 x 30.12) x2		34.65 x 66.73 x 30.12 + (50.98 x 66.73 x 30.12) x2		34.65 x 66.73 x 30.12 + (50.98 x 66.73 x 30.12) x2		
	Shipping Dimensions (WxHxD)	inches	37.32 x 75.28 x 32.76 + (53.66 x 75.28 x 32.76) x2		37.32 x 75.28 x 32.76 + (53.66 x 75.28 x 32.76) x2		37.32 x 75.28 x 32.76 + (53.66 x 75.28 x 32.76) x2		
Operating Temp Range	Cooling <sup>(f)</sup>	°F	5 ~ 120		5 ~ 120		5 ~ 120		
	Heating	°F	-13 ~ 75		-13 ~ 75		-13 ~ 75		

**Note:** Requires two each 4TDK3819B0000A and 4TDK3100B0000A outdoor unit T-joint connections

- (a) Nominal capacity based on 25 ft. of equivalent refrigerant piping with 0 ft. level difference. Cooling: Indoor temperature 80°F DB, 67°F WB/Outdoor temperature 95°F DB, 75°F WB. Heating: Indoor temperature 70°F DB, 60°F WB/Outdoor temperature 47°F DB, 43°F WB.
- (b) Rated per AHRI-1230 Standard conditions (published ratings apply to systems ≤ 300,000 Btuh).
- (c) Actual length (equivalent length in parenthesis).
- (d) If the outdoor unit is installed above the indoor units, the allowable height difference to the furthest indoor unit is 361 ft. If the outdoor unit is installed below the indoor units, the allowable height difference is 131 ft.
- (e) Sound pressure was acquired in a dead room. Actual noise level may be different depending on installation conditions.
- (f) Cooling operation between 23° F and 5° F requires mixed mode condition (at least 50% of the indoor units must be in heating mode).

**Table 13. 208-230V Heat Recovery Triple Modules II**

Model Name			4TVR0384B300NB	4TVR0408B300NB	4TVR0432B300NB				
			2x 4TVR0120B300NB + 4TVR0144B300NB	4TVR0120B300NB + 2x 4TVR0144B300NB	3x 4TVR0144B300NB				
Power Supply			208-230/60/3		208-230/60/3				
Performance	Nominal Tons		32.0		34.0	36.0			
	System Type		Ducted	Non-Ducted	Ducted	Non-Ducted			
	Capacity (Nominal) <sup>(a)</sup>	Cooling	Btuh	384,000	384,000	408,000	408,000	432,000	432,000
		Heating	Btuh	432,000	432,000	459,000	459,000	486,000	486,000
	Capacity (Rated) <sup>(b)</sup>	Cooling	Btuh	366,000	366,000	390,000	390,000	415,000	415,000
		High Temp Heating	Btuh	410,000	410,000	435,000	435,000	460,000	460,000
		Low Temp Heating	Btuh	268,000	268,000	284,000	284,000	300,000	300,000
	AHRI -1230 Efficiency Ratings <sup>(b)</sup>	EER	-	9.50	9.50	9.50	9.50	9.50	9.50
		IEER	-	16.50	19.50	16.40	19.10	16.30	19.10
		COP @ 47°F	-	3.20	3.20	3.20	3.20	3.20	3.20
COP @ 17°F		-	2.05	2.10	2.05	2.05	2.05	2.05	
	SCHE	-	16.50	23.00	19.00	22.00	19.00	21.50	
Power	MCA	A	Each individual outdoor unit requires a separate electrical connection. Reference electrical data for each individual outdoor unit.						
	MOP	A							
	SCCR	kA							
Compressor	Type (Qty.)	-	SSC Scroll (6)		SSC Scroll (6)		SSC Scroll (6)		
	Model Name	-	DS-GB052FBVASG x 6		DS-GB052FBVASG x 6		DS-GB052FBVASG x 6		
	Output	kW each	4.96 x 6		4.96 x 6		4.96 x 6		
	Oil	Type	-	PVE		PVE		PVE	
Initial Charge		fl. oz.	466.6		466.6		466.6		
Fan	Type (Qty.)	-	Propeller (6)		Propeller (6)		Propeller (6)		
	Output (Each)	W	620 x 6		620 x 6		620 x 6		
	Airflow Rate	CFM	(9,180 x2) + 9535		9,180 + (2x 9,535)		9535 x 3		
	External Static Pressure	in. WG	0.31		0.31		0.31		
Piping Connections	Liquid Pipe	Ø inch	3/4" Braze		3/4" Braze		3/4" Braze		
	Gas Pipe	Ø inch	1 5/8" Braze		1 5/8" Braze		1 5/8" Braze		
	High Pressure Gas Pipe (For Hr)	Ø inch	1 3/8" Braze		1 3/8" Braze		1 3/8" Braze		
	Installation Limits	Max Length <sup>(c)</sup>	ft.	656 (722)		656 (722)		656 (722)	
Max Height <sup>(d)</sup>		ft.	361 (131)		361 (131)		361 (131)		
Indoor Unit Connections	Number Of Connectable Indoor Units	-	64		64		64		
	Total Capacity	-	50 to 130% of total outdoor unit capacity						
Refrigerant	Type	-	R410A		R410A		R410A		
	Factory Charge	lbs.	51.8		54.7		57.5		
Sound <sup>(e)</sup>	Sound Pressure	dB(A)	-		-		-		
	Sound Power	dB(A)	-		-		-		
External Dimensions	Net Weight	lbs.	(637 x 2) + 672		(637 x 2) + 672		672 x 2		
	Shipping Weight	lbs.	(679 x 2) + 714		(679 x 2) + 714		714 x 2		
	Net Dimensions (WxHxD)	inches	(50.98 x 66.73 x 30.12) x 3		(50.98 x 66.73 x 30.12) x 3		(50.98 x 66.73 x 30.12) x 3		
	Shipping Dimensions (WxHxD)	inches	(53.66 x 75.28 x 32.76) x 3		(53.66 x 75.28 x 32.76) x 3		(53.66 x 75.28 x 32.76) x 3		
Operating Temp Range	Cooling <sup>(f)</sup>	°F	5 ~ 120		5 ~ 120		5 ~ 120		
	Heating	°F	-13 ~ 75		-13 ~ 75		-13 ~ 75		

**Note:** Requires two each 4TDK3819B0000A and 4TDK3100B0000A outdoor unit T-joint connections

- (a) Nominal capacity based on 25 ft. of equivalent refrigerant piping with 0 ft. level difference. Cooling: Indoor temperature 80°F DB, 67°F WB/Outdoor temperature 95°F DB, 75°F WB. Heating: Indoor temperature 70°F DB, 60°F WB/Outdoor temperature 47°F DB, 43°F WB.
- (b) Rated per AHRI-1230 Standard conditions (published ratings apply to systems ≤ 300,000 Btuh).
- (c) Actual length (equivalent length in parenthesis).
- (d) If the outdoor unit is installed above the indoor units, the allowable height difference to the furthest indoor unit is 361 ft. If the outdoor unit is installed below the indoor units, the allowable height difference is 131 ft.
- (e) Sound pressure was acquired in a dead room. Actual noise level may be different depending on installation conditions.
- (f) Cooling operation between 23° F and 5° F requires mixed mode condition (at least 50% of the indoor units must be in heating mode).



## Product Specifications

**Table 14. 460V Heat Pump Single Modules**

Model Name			4TVH0072B400NB	4TVH0096B400NB	4TVH0120B400NB	4TVH0144B400NB					
Power Supply			460/60/3		460/60/3		460/60/3		460/60/3		
Nominal Tons			6.0		8.0		10.0		12.0		
System Type			Ducted	Non-Ducted	Ducted	Non-Ducted	Ducted	Non-Ducted	Ducted	Non-Ducted	
Performance	Capacity (Nominal) <sup>(a)</sup>	Cooling	Btuh	72,000	72,000	96,000	96,000	120,000	120,000	144,000	144,000
		Heating	Btuh	81,000	81,000	108,000	108,000	135,000	135,000	162,000	162,000
	Capacity (Rated) <sup>(b)</sup>	Cooling	Btuh	69,000	69,000	92,000	92,000	114,000	114,000	138,000	138,000
		High Temp Heating	Btuh	77,000	77,000	103,000	103,000	129,000	129,000	154,000	154,000
		Low Temp Heating	Btuh	51,000	51,000	67,000	67,000	84,000	84,000	100,000	100,000
	AHRI -1230 Efficiency Ratings <sup>(b)</sup>	EER	-	11.50	12.90	11.50	13.90	11.10	12.40	10.80	11.20
		IEER	-	22.50	33.00	22.40	29.60	21.20	27.10	21.10	24.50
		COP @ 47°F	-	3.46	4.15	3.56	4.23	3.43	3.97	3.54	3.64
		COP @ 17°F	-	2.49	2.75	2.45	2.81	2.44	2.53	2.23	2.40
		SCHE	-	-	-	-	-	-	-	-	-
Power	MCA	A	16.4		19		21.7		26.4		
	MOP	A	20		25		30		40		
	SCCR	kA	-		-		-		-		
Compressor	Type (Qty.)	-	SSC Scroll (1)		SSC Scroll (1)		SSC Scroll (1)		SSC Scroll (2)		
	Model Name	-	DS-GB052FAVASG		DS-GB066FAVASG		DS-GB066FAVASG		DS-GB052FAVASG		
	Output	kW	4.96		6.13		6.13		4.96 x 2		
	Oil	Type	-	PVE		PVE		PVE		PVE	
Initial Charge		fl. oz.	77.8		77.8		77.8		155.5		
Fan	Type (Qty.)	-	Propeller (1)		Propeller (2)		Propeller (2)		Propeller (2)		
	Output (Each)	W	400		620		620		620		
	Airflow Rate	CFM	7,240		9,180		9,180		9,535		
	External Static Pressure	in. WG	0.31		0.31		0.31		0.31		
Piping Connections	Liquid Pipe	Ø inch	3/8" Braze		3/8" Braze		1/2" Braze		1/2" Braze		
	Gas Pipe	Ø inch	3/4" Braze		7/8" Braze		1 1/8" Braze		1 1/8" Braze		
	High Pressure Gas Pipe (For HR)	Ø inch	N/A		N/A		N/A		N/A		
	Installation Limits	Max Length <sup>(c)</sup>	ft.	656 (722)		656 (722)		656 (722)		656 (722)	
Max Height <sup>(d)</sup>		ft.	361 (131)		361 (131)		361 (131)		361 (131)		
Indoor Unit Connections	Number Of Connectable Indoor Units	-	12		16		20		25		
	Total Capacity	-	50 to 130% of total outdoor unit capacity								
Refrigerant	Type	-	R-410A		R-410A		R-410A		R-410A		
	Factory Charge	lbs.	12.1		16.3		16.3		19.18		
Sound <sup>(e)</sup>	Sound Pressure	dB(A)	60.0		61.0		61.0		62.0		
	Sound Power	dB(A)	81		81		81		83		
External Dimensions	Net Weight	lbs.	437		540		540		672		
	Shipping Weight	lbs.	472		582		582		714		
	Net Dimensions (WxHxD)	inches	34.65 x 66.73 x 30.12		50.98 x 66.73 x 30.12		50.98 x 66.73 x 30.12		50.98 x 66.73 x 30.12		
	Shipping Dimensions (WxHxD)	inches	37.32 x 75.28 x 32.76		53.66 x 75.28 x 32.76		53.66 x 75.28 x 32.76		53.66 x 75.28 x 32.76		
Operating Temp Range	Cooling	°F	23 ~ 120		23 ~ 120		23 ~ 120		23 ~ 120		
	Heating	°F	-13 ~ 75		-13 ~ 75		-13 ~ 75		-13 ~ 75		

(a) Nominal capacity based on 25 ft. of equivalent refrigerant piping with 0 ft. level difference. Cooling: Indoor temperature 80°F DB, 67°F WB/Outdoor temperature 95°F DB, 75°F WB. Heating: Indoor temperature 70°F DB, 60°F WB/Outdoor temperature 47°F DB, 43°F WB.

(b) Rated per AHRI-1230 Standard conditions.

(c) Actual length (equivalent length in parenthesis).

(d) If the outdoor unit is installed above the indoor units, the allowable height difference to the furthest indoor unit is 361 ft. If the outdoor unit is installed below the indoor units, the allowable height difference is 131 ft.

(e) Sound pressure was acquired in a dead room. Actual noise level may be different depending on installation conditions.

**Table 15. 460V Heat Pump Dual Modules I**

Model Name			4TVHO168B400NB	4TVHO192B400NB	4TVHO216B400NB				
			4TVHO072B400NB + 4TVHO096B400NB	4TVHO072B400NB + 4TVHO120B400NB	4TVHO072B400NB + 4TVHO144B400NB				
Power Supply			460/60/3		460/60/3				
Performance	Nominal Tons		14.0		16.0	18.0			
	System Type		Ducted	Non-Ducted	Ducted	Non-Ducted			
	Capacity (Nominal) <sup>(a)</sup>	Cooling	Btuh	168,000	168,000	192,000	192,000	216,000	216,000
		Heating	Btuh	189,000	189,000	216,000	216,000	243,000	243,000
	Capacity (Rated) <sup>(b)</sup>	Cooling	Btuh	160,000	160,000	184,000	184,000	206,000	206,000
		High Temp Heating	Btuh	180,000	180,000	206,000	206,000	230,000	230,000
		Low Temp Heating	Btuh	118,000	118,000	134,000	134,000	150,000	150,000
	AHRI -1230 Efficiency Ratings <sup>(b)</sup>	EER	-	11.30	12.10	10.90	11.20	10.60	10.80
		IEER	-	20.50	25.30	21.50	24.20	20.50	22.40
		COP @ 47°F	-	3.44	3.94	3.34	3.83	3.34	3.63
COP @ 17°F		-	2.43	2.65	2.42	2.59	2.31	2.52	
Power	MCA	A	Each individual outdoor unit requires a separate electrical connection. Reference electrical data for each individual outdoor unit.						
	MOP	A							
	SCCR	kA							
Compressor	Type (Qty.)	-	SSC Scroll (2)		SSC Scroll (2)		SSC Scroll (2)		
	Model Name		-	DS-GB052FAVASG + DS-GB066FAVASG		DS-GB052FAVASG + DS-GB066FAVASG		DS-GB052FAVASG x 2	
	Output		kW	4.96 + 6.13		4.96 + 6.13		4.96 x 3	
	Oil	Type	-	PVE		PVE		PVE	
Initial Charge		fl. oz.	155.5		155.5		233.3		
Fan	Type (Qty.)	-	Propeller (3)		Propeller (3)		Propeller (3)		
	Output (Each)		W	400 + 620 x 2		400 + 620 x 2		400 + 620 x 2	
	Airflow Rate		CFM	7,240 + 9,180		7,240 + 9,180		7,240 + 9,535	
	External Static Pressure		in. WG	0.31		0.31		0.31	
Piping Connections	Liquid Pipe		Ø inch	5/8" Braze		5/8" Braze		5/8" Braze	
	Gas Pipe		Ø inch	1 1/8" Braze		1 1/8" Braze		1 1/8" Braze	
	High Pressure Gas Pipe (For HR)		Ø inch	N/A		N/A		N/A	
	Installation Limits	Max Length <sup>(c)</sup>	ft.	656 (722)		656 (722)		656 (722)	
Max Height <sup>(d)</sup>		ft.	361 (131)		361 (131)		361 (131)		
Indoor Unit Connections	Number Of Connectable Indoor Units		-	29		33		37	
	Total Capacity		-	50 to 130% of total outdoor unit capacity					
Refrigerant	Type		-	R410A		R410A		R410A	
	Factory Charge		lbs.	28.4		28.4		31.3	
Sound <sup>(e)</sup>	Sound Pressure		dB(A)	-		-		-	
	Sound Power		dB(A)	-		-		-	
External Dimensions	Net Weight		lbs.	436 + 540		436 + 540		436 + 672	
	Shipping Weight		lbs.	472 + 582		472 + 582		472 + 714	
	Net Dimensions (WxHxD)		inches	34.65 x 66.73 x 30.12 + 50.98 x 66.73 x 30.12		34.65 x 66.73 x 30.12 + 50.98 x 66.73 x 30.12		34.65 x 66.73 x 30.12 + 50.98 x 66.73 x 30.12	
	Shipping Dimensions (WxHxD)		inches	37.32 x 75.28 x 32.76 + 53.66 x 75.28 x 32.76		37.32 x 75.28 x 32.76 + 53.66 x 75.28 x 32.76		37.32 x 75.28 x 32.76 + 53.66 x 75.28 x 32.76	
Operating Temp Range	Cooling		°F	23 ~ 120		23 ~ 120		23 ~ 120	
	Heating		°F	-13 ~ 75		-13 ~ 75		-13 ~ 75	

**Note:** Requires 4TDK3819B0000A outdoor unit T-joint connection

(a) Nominal capacity based on 25 ft. of equivalent refrigerant piping with 0 ft. level difference. Cooling: Indoor temperature 80°F DB, 67°F WB/Outdoor temperature 95°F DB, 75°F WB. Heating: Indoor temperature 70°F DB, 60°F WB/Outdoor temperature 47°F DB, 43°F WB.

(b) Rated per AHRI-1230 Standard conditions.

(c) Actual length (equivalent length in parenthesis).

(d) If the outdoor unit is installed above the indoor units, the allowable height difference to the furthest indoor unit is 361 ft. If the outdoor unit is installed below the indoor units, the allowable height difference is 131 ft.

(e) Sound pressure was acquired in a dead room. Actual noise level may be different depending on installation conditions.



## Product Specifications

**Table 16. 460V Heat Pump Dual Modules II**

Model Name			4TVH0240B400NB	4TVH0264B400NB	4TVH0120B400NB + 4TVH0144B400NB	4TVH0288B400NB			
			2x 4TVH0120B400NB			2x 4TVH0144B400NB			
Power Supply			460/60/3		460/60/3		460/60/3		
Performance	Nominal Tons		20.0		22.0		24.0		
	System Type		Ducted	Non-Ducted	Ducted	Non-Ducted	Ducted	Non-Ducted	
	Capacity (Nominal) <sup>(a)</sup>	Cooling	Btuh	240,000	240,000	264,000	264,000	288,000	288,000
		Heating	Btuh	270,000	270,000	297,000	297,000	324,000	324,000
	Capacity (Rated) <sup>(b)</sup>	Cooling	Btuh	228,000	228,000	252,000	252,000	276,000	276,000
		High Temp Heating	Btuh	258,000	258,000	282,000	282,000	308,000	308,000
		Low Temp Heating	Btuh	168,000	168,000	184,000	184,000	200,000	200,000
	AHRI -1230 Efficiency Ratings <sup>(b)</sup>	EER	-	10.60	10.70	10.10	10.10	10.00	9.90
		IEER	-	18.50	22.10	18.50	21.50	18.60	21.00
		COP @ 47°F	-	3.24	3.65	3.25	3.45	3.25	3.26
COP @ 17°F		-	2.40	2.54	2.26	2.41	2.12	2.29	
	SCHE	-	-	-	-	-	-	-	
Power	MCA	A	Each individual outdoor unit requires a separate electrical connection. Reference electrical data for each individual outdoor unit.						
	MOP	A							
	SCCR	KA							
Compressor	Type (Qty.)		-	SSC Scroll (2)	SSC Scroll (3)	SSC Scroll (4)			
	Model Name		-	DS-GB066FAVASG x 2	DS-GB052FAVASG x 2 + DS-GB066FAVASG	DS-GB052FAVASG x 4			
	Output		kW	6.13 x 2	(4.96 x 2) + 6.13	4.96 x 4			
	Oil	Type	-	PVE		PVE			
Initial Charge		fl. oz.	155.5		233.3		311.1		
Fan	Type (Qty.)		-	Propeller (4)	Propeller (4)	Propeller (4)			
	Output (Each)		W	620 x 4		620 x 4		620 x 4	
	Airflow Rate		CFM	9180 x 2		9,180 + 9,535		9535 x 2	
	External Static Pressure		in. WG	0.31		0.31		0.31	
Piping Connections	Liquid Pipe		Ø inch	5/8" Braze		3/4" Braze		3/4" Braze	
	Gas Pipe		Ø inch	1 1/8" Braze		1 3/8" Braze		1 3/8" Braze	
	High Pressure Gas Pipe (For HR)		Ø inch	N/A		N/A		N/A	
	Installation Limits	Max Length <sup>(c)</sup>	ft.	656 (722)		656 (722)		656 (722)	
Max Height <sup>(d)</sup>		ft.	361 (131)		361 (131)		361 (131)		
Indoor Unit Connections	Number Of Connectable Indoor Units		-	41		45		49	
	Total Capacity		-	50 to 130% of total outdoor unit capacity					
Refrigerant	Type		-	R410A		R410A		R410A	
	Factory Charge		lbs.	32.6		35.5		38.4	
Sound <sup>(e)</sup>	Sound Pressure		dB(A)	-		-		-	
	Sound Power		dB(A)	-		-		-	
External Dimensions	Net Weight		lbs.	540 x 2		540 + 672		672 x 2	
	Shipping Weight		lbs.	582 x 2		582 + 714		714 x 2	
	Net Dimensions (WxHxD)		inches	(50.98 x 66.73 x 30.12) x 2		(50.98 x 66.73 x 30.12) x 2		(50.98 x 66.73 x 30.12) x 2	
Shipping Dimensions (WxHxD)		inches	(53.66 x 75.28 x 32.76) x 2		(53.66 x 75.28 x 32.76) x 2		(53.66 x 75.28 x 32.76) x 2		
Operating Temp Range	Cooling		°F	23 ~ 120		23 ~ 120		23 ~ 120	
	Heating		°F	-13 ~ 75		-13 ~ 75		-13 ~ 75	

**Note:** Requires 4TDK3819B0000A outdoor unit T-joint connection

- (a) Nominal capacity based on 25 ft. of equivalent refrigerant piping with 0 ft. level difference. Cooling: Indoor temperature 80°F DB, 67°F WB/Outdoor temperature 95°F DB, 75°F WB. Heating: Indoor temperature 70°F DB, 60°F WB/Outdoor temperature 47°F DB, 43°F WB.
- (b) Rated per AHRI-1230 Standard conditions.
- (c) Actual length (equivalent length in parenthesis).
- (d) If the outdoor unit is installed above the indoor units, the allowable height difference to the furthest indoor unit is 361 ft. If the outdoor unit is installed below the indoor units, the allowable height difference is 131 ft.
- (e) Sound pressure was acquired in a dead room. Actual noise level may be different depending on installation conditions.

**Table 17. 460V Heat Pump Triple Modules I**

Model Name			4TVH0312B400NB	4TVH0336B400NB	4TVH0360B400NB				
			4TVH0072B400NB + 4TVH0096B400NB + 4TVH0144B400NB	4TVH0072B400NB + 4TVH0120B400NB + 4TVH0144B400NB	4TVH0072B400NB + 2x 4TVH0144B400NB				
Power Supply			460/60/3		460/60/3				
Nominal Tons			26.0		30.0				
System Type			Ducted	Non-Ducted	Ducted				
Performance	Capacity (Nominal) <sup>(a)</sup>	Cooling	Btuh	312,000	312,000	336,000	336,000	360,000	360,000
		Heating	Btuh	351,000	351,000	378,000	378,000	405,000	405,000
	Capacity (Rated) <sup>(b)</sup>	Cooling	Btuh	298,000	298,000	320,000	320,000	344,000	344,000
		High Temp Heating	Btuh	334,000	334,000	360,000	360,000	386,000	386,000
		Low Temp Heating	Btuh	218,000	218,000	234,000	234,000	250,000	250,000
	AHRI -1230 Efficiency Ratings <sup>(b)</sup>	EER	-	10.30	10.60	10.00	10.20	9.80	9.80
		IEER	-	18.10	20.90	17.00	20.50	16.60	20.00
		COP @ 47°F	-	3.20	3.38	3.20	3.27	3.20	3.22
		COP @ 17°F	-	2.25	2.51	2.21	2.39	2.11	2.31
	SCHE	-	-	-	-	-	-	-	-
Power	MCA	A	Each individual outdoor unit requires a separate electrical connection. Reference electrical data for each individual outdoor unit.						
	MOP	A							
	SCCR	kA							
Compressor	Type (Qty.)	-	SSC Scroll (4)		SSC Scroll (4)		SSC Scroll (5)		
	Model Name	-	DS-GB052FAVASG x 3 + DS-GB066FAVASG		DS-GB052FAVASG x 3 + DS-GB066FAVASG		DS-GB052FAVASG x 5		
	Output	kW	(4.96 x 3) + 6.13		(4.96 x 3) + 6.13		4.96 x 5		
	Oil	Type	-	PVE		PVE		PVE	
	Initial Charge	fl. oz.	311.1		311.1		388.9		
Fan	Type (Qty.)	-	Propeller (5)		Propeller (5)		Propeller (5)		
	Output (Each)	W	400 + 620 x 4		400 + 620 x 4		400 + 620 x 4		
	Airflow Rate	CFM	7,240 + 9,180 + 9,535		7,240 + 9,180 + 9,535		7,240 + (9,535 x2)		
	External Static Pressure	in. WG	0.31		0.31		0.31		
Piping Connections	Liquid Pipe	Ø inch	3/4" Braze		3/4" Braze		3/4" Braze		
	Gas Pipe	Ø inch	1 3/8" Braze		1 3/8" Braze		1 5/8" Braze		
	High Pressure Gas Pipe (For HR)	Ø inch	N/A		N/A		N/A		
	Installation Limits	Max Length <sup>(c)</sup>	ft.	656 (722)		656 (722)		656 (722)	
		Max Height <sup>(d)</sup>	ft.	361 (131)		361 (131)		361 (131)	
Indoor Unit Connections	Number Of Connectable Indoor Units	-	54		58		62		
	Total Capacity	-	50 to 130% of total outdoor unit capacity						
Refrigerant	Type	-	R-410A		R-410A		R-410A		
	Factory Charge	lbs.	47.6		47.6		50.5		
Sound <sup>(e)</sup>	Sound Pressure	dB(A)	-		-		-		
	Sound Power	dB(A)	-		-		-		
External Dimensions	Net Weight	lbs.	437 + 540 + 672		437 + 540 + 672		437 + (672 x2)		
	Shipping Weight	lbs.	472 + 582 + 714		472 + 582 + 714		472 + (714 x2)		
	Net Dimensions (WxHxD)	inches	34.65 x 66.73 x 30.12 + (50.98 x 66.73 x 30.12) x2		34.65 x 66.73 x 30.12 + (50.98 x 66.73 x 30.12) x2		34.65 x 66.73 x 30.12 + (50.98 x 66.73 x 30.12) x2		
		inches	37.32 x 75.28 x 32.76 + (53.66 x 75.28 x 32.76) x2		37.32 x 75.28 x 32.76 + (53.66 x 75.28 x 32.76) x2		37.32 x 75.28 x 32.76 + (53.66 x 75.28 x 32.76) x2		
Operating Temp Range	Cooling	°F	23 ~ 120		23 ~ 120		23 ~ 120		
	Heating	°F	-13 ~ 75		-13 ~ 75		-13 ~ 75		

**Note:** Requires two 4TDK3819B0000A outdoor unit T-joint connections

- (a) Nominal capacity based on 25 ft. of equivalent refrigerant piping with 0 ft. level difference. Cooling: Indoor temperature 80°F DB, 67°F WB/Outdoor temperature 95°F DB, 75°F WB. Heating: Indoor temperature 70°F DB, 60°F WB/Outdoor temperature 47°F DB, 43°F WB.
- (b) Rated per AHRI-1230 Standard conditions (published ratings apply to systems < 300,000 Btuh).
- (c) Actual length (equivalent length in parenthesis).
- (d) If the outdoor unit is installed above the indoor units, the allowable height difference to the furthest indoor unit is 361 ft. If the outdoor unit is installed below the indoor units, the allowable height difference is 131 ft.
- (e) Sound pressure was acquired in a dead room. Actual noise level may be different depending on installation conditions.



## Product Specifications

**Table 18. 460V Heat Pump Triple Modules II**

Model Name			4TVH0384B400NB	4TVH0408B400NB	4TVH0432B400NB				
			2x 4TVH0120B400NB + 4TVH0144B400NB	4TVH0120B400NB + 2x 4TVH0144B400NB	3x 4TVH0144B400NB				
Power Supply			460/60/3	460/60/3	460/60/3				
Performance	Nominal Tons		32.0		34.0	36.0			
	System Type		Ducted	Non-Ducted	Ducted	Non-Ducted			
	Capacity (Nominal) <sup>(a)</sup>	Cooling	Btuh	384,000	384,000	408,000	408,000	432,000	432,000
		Heating	Btuh	432,000	432,000	459,000	459,000	486,000	486,000
	Capacity (Rated) <sup>(b)</sup>	Cooling	Btuh	366,000	366,000	390,000	390,000	415,000	415,000
		High Temp Heating	Btuh	410,000	410,000	435,000	435,000	460,000	460,000
		Low Temp Heating	Btuh	268,000	268,000	284,000	284,000	300,000	300,000
	AHRI -1230 Efficiency Ratings <sup>(b)</sup>	EER	-	9.50	9.50	9.50	9.50	9.50	9.50
		IEER	-	16.20	19.50	16.30	19.10	16.30	19.10
		COP @ 47°F	-	3.20	3.20	3.20	3.20	3.20	3.20
COP @ 17°F		-	2.05	2.10	2.05	2.05	2.05	2.05	
	SCHE	-	-	-	-	-	-	-	
Power	MCA	A	Each individual outdoor unit requires a separate electrical connection. Reference electrical data for each individual outdoor unit.						
	MOP	A							
	SCCR	kA							
Compressor	Type (Qty.)		SSC Scroll (4)		SSC Scroll (5)	SSC Scroll (6)			
	Model Name		DS-GB052FAVASG x 2 + DS-GB066FAVASG x 2		DS-GB052FAVASG x 4 + DS-GB066FAVASG	DS-GB052FAVASG x 6			
	Output		kW (4.96 x 2) + (6.13 x 2)		(4.96 x 4) + 6.13	4.96 x 6			
	Oil	Type	-	PVE		PVE	PVE		
Initial Charge		fl. oz.	311.1		388.9	466.6			
Fan	Type (Qty.)		Propeller (6)		Propeller (6)	Propeller (6)			
	Output (Each)		W 620 x 6		620 x 6	620 x 6			
	Airflow Rate		CFM (9,180 x 2) + 9535		9,180 + (2x 9,535)	9535 x 3			
	External Static Pressure		in. WG 0.31		0.31	0.31			
Piping Connections	Liquid Pipe		Ø inch 3/4" Braze		3/4" Braze	3/4" Braze			
	Gas Pipe		Ø inch 1 5/8" Braze		1 5/8" Braze	1 5/8" Braze			
	High Pressure Gas Pipe (For HR)		Ø inch N/A		N/A	N/A			
	Installation Limits	Max Length <sup>(c)</sup>	ft.	656 (722)		656 (722)	656 (722)		
Max Height <sup>(d)</sup>		ft.	361 (131)		361 (131)	361 (131)			
Indoor Unit Connections	Number Of Connectable Indoor Units		-		64	64			
	Total Capacity		-		50 to 130% of total outdoor unit capacity				
Refrigerant	Type		-		R410A	R410A			
	Factory Charge		lbs.		51.8	54.7	57.5		
Sound <sup>(e)</sup>	Sound Pressure		dB(A)		-	-			
	Sound Power		dB(A)		-	-			
External Dimensions	Net Weight		lbs. (540 x 2) + 672		540 + (672 x 2)	672 x 3			
	Shipping Weight		lbs. (582 x 2) + 714		582 + (714 x 2)	714 x 3			
	Net Dimensions (WxHxD)		inches (50.98 x 66.73 x 30.12) x 3		(50.98 x 66.73 x 30.12) x 3	(50.98 x 66.73 x 30.12) x 3			
Shipping Dimensions (WxHxD)		inches (53.66 x 75.28 x 32.76) x 3		(53.66 x 75.28 x 32.76) x 3	(53.66 x 75.28 x 32.76) x 3				
Operating Temp Range	Cooling		°F 23 ~ 120		23 ~ 120	23 ~ 120			
	Heating		°F -13 ~ 75		-13 ~ 75	-13 ~ 75			

**Note:** Requires two 4TDK3819B0000A outdoor unit T-joint connections.

(a) Nominal capacity based on 25 ft. of equivalent refrigerant piping with 0 ft. level difference. Cooling: Indoor temperature 80°F DB, 67°F WB/Outdoor temperature 95°F DB, 75°F WB. Heating: Indoor temperature 70°F DB, 60°F WB/Outdoor temperature 47°F DB, 43°F WB.

(b) Rated per AHRI-1230 Standard conditions (published ratings apply to systems ≤ 300,000 Btuh).

(c) Actual length (equivalent length in parenthesis).

(d) If the outdoor unit is installed above the indoor units, the allowable height difference to the furthest indoor unit is 361 ft. If the outdoor unit is installed below the indoor units, the allowable height difference is 131 ft.

(e) Sound pressure was acquired in a dead room. Actual noise level may be different depending on installation conditions.



**Table 19. 460V Heat Recovery Single Modules**

Model Name			4TVR0072B400NB	4TVR0096B400NB	4TVR0120B400NB	4TVR0144B400NB					
Power Supply			460/60/3		460/60/3		460/60/3		460/60/3		
Nominal Tons			6.0		8.0		10.0		12.0		
System Type			Ducted	Non-Ducted	Ducted	Non-Ducted	Ducted	Non-Ducted	Ducted	Non-Ducted	
Performance	Capacity (Nominal) <sup>(a)</sup>	Cooling	Btuh	72,000	72,000	96,000	96,000	120,000	120,000	144,000	144,000
		Heating	Btuh	81,000	81,000	108,000	108,000	135,000	135,000	162,000	162,000
	Capacity (Rated) <sup>(b)</sup>	Cooling	Btuh	69,000	69,000	92,000	92,000	114,000	114,000	138,000	138,000
		High Temp Heating	Btuh	77,000	77,000	103,000	103,000	129,000	129,000	154,000	154,000
		Low Temp Heating	Btuh	51,000	51,000	67,000	67,000	84,000	84,000	100,000	100,000
	AHRI -1230 Efficiency Ratings <sup>(b)</sup>	EER	-	11.50	12.90	11.50	13.90	11.10	12.40	10.80	11.20
		IEER	-	22.50	33.00	22.40	29.60	21.20	27.10	21.10	24.50
		COP @ 47°F	-	3.46	4.15	3.56	4.23	3.43	3.97	3.54	3.64
		COP @ 17°F	-	2.49	2.75	2.45	2.81	2.44	2.53	2.23	2.40
		SCHE	-	26.00	28.00	26.50	31.50	25.50	30.00	25.00	27.50
Power	MCA	A	16.4		19		21.7		26.4		
	MOP	A	20		25		30		40		
	SCCR	kA	-		-		-		-		
Compressor	Type (Qty.)	-	SSC Scroll (1)		SSC Scroll (1)		SSC Scroll (1)		SSC Scroll (2)		
	Model Name	-	DS-GB052FAVASG		DS-GB066FAVASG		DS-GB066FAVASG		DS-GB052FAVASG		
	Output	kW	4.96		6.13		6.13		4.96 x 2		
	Oil	Type	-	PVE		PVE		PVE		PVE	
		Initial Charge	fl. oz.	77.8		77.8		77.8		155.5	
Fan	Type (Qty.)	-	Propeller (1)		Propeller (2)		Propeller (2)		Propeller (2)		
	Output (Each)	W	400		620		620		620		
	Airflow Rate	CFM	7,240		9,180		9,180		9,535		
	External Static Pressure	in. WG	0.31		0.31		0.31		0.31		
Piping Connections	Liquid Pipe	Ø inch	3/8" Braze		3/8" Braze		1/2" Braze		1/2" Braze		
	Gas Pipe	Ø inch	3/4" Braze		7/8" Braze		1 1/8" Braze		1 1/8" Braze		
	High Pressure Gas Pipe (For HR)	Ø inch	5/8" Braze		3/4" Braze		7/8" Braze		7/8" Braze		
	Installation Limits	Max Length <sup>(c)</sup>	ft.	656 (722)		656 (722)		656 (722)		656 (722)	
		Max Height <sup>(d)</sup>	ft.	361 (131)		361 (131)		361 (131)		361 (131)	
Indoor Unit Connections	Number Of Connectable Indoor Units	-	12		16		20		25		
	Total Capacity	-	50 to 130% of total outdoor unit capacity								
Refrigerant	Type	-	R-410A		R-410A		R-410A		R-410A		
	Factory Charge	lbs.	12.1		16.3		16.3		19.18		
Sound <sup>(e)</sup>	Sound Pressure	dB(A)	60.0		61.0		61.0		62.0		
	Sound Power	dB(A)	81		81		81		83		
External Dimensions	Net Weight	lbs.	445		553		553		692		
	Shipping Weight	lbs.	481		595		595		734		
	Net Dimensions (WxHxD)	inches	34.65 x 66.73 x 30.12		50.98 x 66.73 x 30.12		50.98 x 66.73 x 30.12		50.98 x 66.73 x 30.12		
	Shipping Dimensions (WxHxD)	inches	37.32 x 75.28 x 32.76		53.66 x 75.28 x 32.76		53.66 x 75.28 x 32.76		53.66 x 75.28 x 32.76		
Operating Temp Range	Cooling <sup>(f)</sup>	°F	5 ~ 120		5 ~ 120		5 ~ 120		5 ~ 120		
	Heating	°F	-13 ~ 75		-13 ~ 75		-13 ~ 75		-13 ~ 75		

(a) Nominal capacity based on 25 ft. of equivalent refrigerant piping with 0 ft. level difference. Cooling: Indoor temperature 80°F DB, 67°F WB/Outdoor temperature 95°F DB, 75°F WB. Heating: Indoor temperature 70°F DB, 60°F WB/Outdoor temperature 47°F DB, 43°F WB.

(b) Rated per AHRI-1230 Standard conditions.

(c) Actual length (equivalent length in parenthesis).

(d) If the outdoor unit is installed above the indoor units, the allowable height difference to the furthest indoor unit is 361 ft. If the outdoor unit is installed below the indoor units, the allowable height difference is 131 ft.

(e) Sound pressure was acquired in a dead room. Actual noise level may be different depending on installation conditions.

(f) Cooling operation between 23° F and 5° F requires mixed mode condition (at least 50% of the indoor units must be in heating mode).



## Product Specifications

**Table 20. 460V Heat Recovery Dual Modules I**

Model Name			4TVR0168B400NB	4TVR0192B400NB	4TVR0216B400NB				
			4TVR0072B400NB + 4TVR0096B400NB	4TVR0072B400NB + 4TVR0120B400NB	4TVR0072B400NB + 4TVR0144B400NB				
Power Supply			460/60/3		460/60/3				
Performance	Nominal Tons		14.0		16.0	18.0			
	System Type		Ducted	Non-Ducted	Ducted	Non-Ducted			
	Capacity (Nominal) <sup>(a)</sup>	Cooling	Btuh	168,000	168,000	192,000	192,000	216,000	216,000
		Heating	Btuh	189,000	189,000	216,000	216,000	243,000	243,000
	Capacity (Rated) <sup>(b)</sup>	Cooling	Btuh	160,000	160,000	184,000	184,000	206,000	206,000
		High Temp Heating	Btuh	180,000	180,000	206,000	206,000	230,000	230,000
		Low Temp Heating	Btuh	118,000	118,000	134,000	134,000	150,000	150,000
	AHRI - 1230 Efficiency Ratings <sup>(b)</sup>	EER	-	11.30	12.10	10.90	11.20	10.60	10.80
		IEER	-	20.50	25.30	21.50	24.20	20.50	22.40
		COP @ 47°F	-	3.44	3.94	3.34	3.83	3.34	3.63
COP @ 17°F		-	2.43	2.65	2.42	2.59	2.31	2.52	
	SCHE	-	23.50	27.00	23.50	26.50	23.00	25.50	
Power	MCA	A	Each individual outdoor unit requires a separate electrical connection. Reference electrical data for each individual outdoor unit.						
	MOP	A							
	SCCR	kA							
Compressor	Type (Qty.)		SSC Scroll (2)		SSC Scroll (2)	SSC Scroll (2)			
	Model Name		DS-GB052FAVASG + DS-GB066FAVASG		DS-GB052FAVASG + DS-GB066FAVASG	DS-GB052FAVASG x 2			
	Output		kW		4.96 + 6.13	4.96 + 6.13	4.96 x 3		
	Oil	Type	PVE		PVE	PVE			
		Initial Charge	fl. oz.		155.5	155.5	233.3		
Fan	Type (Qty.)		Propeller (3)		Propeller (3)	Propeller (3)			
	Output (Each)		W		400 + 620 x 2	400 + 620 x 2	400 + 620 x 2		
	Airflow Rate		CFM		7,240 + 9,180	7,240 + 9,180	7,240 + 9,535		
	External Static Pressure		in. WG		0.31	0.31	0.31		
Piping Connections	Liquid Pipe		Ø inch		5/8" Braze	5/8" Braze	5/8" Braze		
	Gas Pipe		Ø inch		1 1/8" Braze	1 1/8" Braze	1 1/8" Braze		
	High Pressure Gas Pipe (For HR)		Ø inch		7/8" Braze	1 1/8" Braze	1 1/8" Braze		
	Installation Limits	Max Length <sup>(c)</sup>	ft.		656 (722)	656 (722)	656 (722)		
		Max Height <sup>(d)</sup>	ft.		361 (131)	361 (131)	361 (131)		
Indoor Unit Connections	Number Of Connectable Indoor Units		-		29	33	37		
	Total Capacity		-		50 to 130% of total outdoor unit capacity				
Refrigerant	Type		-		R-410A	R-410A	R-410A		
	Factory Charge		lbs.		28.4	28.4	31.3		
Sound <sup>(e)</sup>	Sound Pressure		dB(A)		-	-	-		
	Sound Power		dB(A)		-	-	-		
External Dimensions	Net Weight		lbs.		445 + 553	445 + 553	445 + 692		
	Shipping Weight		lbs.		481 + 595	481 + 595	481 + 734		
	Net Dimensions (WxHxD)		inches		34.65 x 66.73 x 30.12 + 50.98 x 66.73 x 30.12	34.65 x 66.73 x 30.12 + 50.98 x 66.73 x 30.12	34.65 x 66.73 x 30.12 + 50.98 x 66.73 x 30.12		
	Shipping Dimensions (WxHxD)		inches		37.32 x 75.28 x 32.76 + 53.66 x 75.28 x 32.76	37.32 x 75.28 x 32.76 + 53.66 x 75.28 x 32.76	37.32 x 75.28 x 32.76 + 53.66 x 75.28 x 32.76		
Operating Temp Range	Cooling <sup>(f)</sup>		°F		5 ~ 120	5 ~ 120	5 ~ 120		
	Heating		°F		-13 ~ 75	-13 ~ 75	-13 ~ 75		

**Note:** Requires 4TDK3819B0000A and 4TDK3100B0000A outdoor unit T-joint connections

- (a) Nominal capacity based on 25 ft. of equivalent refrigerant piping with 0 ft. level difference. Cooling: Indoor temperature 80°F DB, 67°F WB/Outdoor temperature 95°F DB, 75°F WB. Heating: Indoor temperature 70°F DB, 60°F WB/Outdoor temperature 47°F DB, 43°F WB.
- (b) Rated per AHRI-1230 Standard conditions.
- (c) Actual length (equivalent length in parenthesis).
- (d) If the outdoor unit is installed above the indoor units, the allowable height difference to the furthest indoor unit is 361 ft. If the outdoor unit is installed below the indoor units, the allowable height difference is 131 ft.
- (e) Sound pressure was acquired in a dead room. Actual noise level may be different depending on installation conditions.
- (f) Cooling operation between 23° F and 5° F requires mixed mode condition (at least 50% of the indoor units must be in heating mode).

## Product Specifications

**Table 21. 460V Heat Recovery Dual Modules II**

Model Name			4TVR0240B400NB	4TVR0264B400NB		4TVR0288B400NB			
			2x 4TVR0120B400NB		4TVR0120B400NB + 4TVR0144B400NB		2x 4TVR0144B400NB		
Power Supply			460/60/3		460/60/3		460/60/3		
Performance	Nominal Tons		20.0		22.0		24.0		
	System Type		Ducted	Non-Ducted	Ducted	Non-Ducted	Ducted	Non-Ducted	
	Capacity (Nominal) <sup>(a)</sup>	Cooling	Btuh	240,000	240,000	264,000	264,000	288,000	288,000
		Heating	Btuh	270,000	270,000	297,000	297,000	324,000	324,000
	Capacity (Rated) <sup>(b)</sup>	Cooling	Btuh	228,000	228,000	252,000	252,000	276,000	276,000
		High Temp Heating	Btuh	258,000	258,000	282,000	282,000	308,000	308,000
		Low Temp Heating	Btuh	168,000	168,000	184,000	184,000	200,000	200,000
	AHRI -1230 Efficiency Ratings <sup>(b)</sup>	EER	-	10.60	10.70	10.10	10.10	10.00	9.90
		IEER	-	18.50	22.10	18.50	21.50	18.60	21.00
		COP @ 47°F	-	3.24	3.65	3.25	3.45	3.25	3.26
COP @ 17°F		-	2.40	2.54	2.26	2.41	2.12	2.29	
	SCHE	-	22.50	25.50	22.00	24.50	21.50	23.50	
Power	MCA	A	Each individual outdoor unit requires a separate electrical connection. Reference electrical data for each individual outdoor unit.						
	MOP	A							
	SCCR	kA							
Compressor	Type (Qty.)		-	SSC Scroll (2)	SSC Scroll (3)	SSC Scroll (4)			
	Model Name		-	DS-GB066FAVASG x 2	DS-GB052FAVASG x 2 + DS-GB066FAVASG	DS-GB052FAVASG x 4			
	Output		kW	6.13 x 2	(4.96 x 2) + 6.13	4.96 x 4			
	Oil	Type	-	PVE		PVE			
Initial Charge		fl. oz.	155.5		233.3		311.1		
Fan	Type (Qty.)		-	Propeller (4)	Propeller (4)		Propeller (4)		
	Output (Each)		W	620 x 4		620 x 4		620 x 4	
	Airflow Rate		CFM	9180 x 2		9,180 + 9,535		9535 x 2	
	External Static Pressure		in. WG	0.31		0.31		0.31	
Piping Connections	Liquid Pipe		Ø inch	5/8" Braze		3/4" Braze		3/4" Braze	
	Gas Pipe		Ø inch	1 1/8" Braze		1 3/8" Braze		1 3/8" Braze	
	High Pressure Gas Pipe (For HR)		Ø inch	1 1/8" Braze		1 1/8" Braze		1 1/8" Braze	
	Installation Limits	Max Length <sup>(c)</sup>	ft.	656 (722)		656 (722)		656 (722)	
Max Height <sup>(d)</sup>		ft.	361 (131)		361 (131)		361 (131)		
Indoor Unit Connections	Number Of Connectable Indoor Units		-	41		45		49	
	Total Capacity		-	50 to 130% of total outdoor unit capacity					
Refrigerant	Type		-	R-410A		R-410A		R-410A	
	Factory Charge		lbs.	32.6		35.5		38.4	
Sound <sup>(e)</sup>	Sound Pressure		dB(A)	-		-		-	
	Sound Power		dB(A)	-		-		-	
External Dimensions	Net Weight		lbs.	553 x 2		553 + 692		692 x 2	
	Shipping Weight		lbs.	595 x 2		595 + 734		734 x 2	
	Net Dimensions (WxHxD)		inches	(50.98 x 66.73 x 30.12) x 2		(50.98 x 66.73 x 30.12) x 2		(50.98 x 66.73 x 30.12) x 2	
	Shipping Dimensions (WxHxD)		inches	(53.66 x 75.28 x 32.76) x 2		(53.66 x 75.28 x 32.76) x 2		(53.66 x 75.28 x 32.76) x 2	
Operating Temp Range	Cooling <sup>(f)</sup>		°F	5 ~ 120		5 ~ 120		5 ~ 120	
	Heating		°F	-13 ~ 75		-13 ~ 75		-13 ~ 75	

**Note:** Requires 4TDK3819B0000A and 4TDK3100B0000A outdoor unit T-joint connections

- (a) Nominal capacity based on 25 ft. of equivalent refrigerant piping with 0 ft. level difference. Cooling: Indoor temperature 80°F DB, 67°F WB/Outdoor temperature 95°F DB, 75°F WB. Heating: Indoor temperature 70°F DB, 60°F WB/Outdoor temperature 47°F DB, 43°F WB.
- (b) Rated per AHRI-1230 Standard conditions.
- (c) Actual length (equivalent length in parenthesis).
- (d) If the outdoor unit is installed above the indoor units, the allowable height difference to the furthest indoor unit is 361 ft. If the outdoor unit is installed below the indoor units, the allowable height difference is 131 ft.
- (e) Sound pressure was acquired in a dead room. Actual noise level may be different depending on installation conditions.
- (f) Cooling operation between 23° F and 5° F requires mixed mode condition (at least 50% of the indoor units must be in heating mode).



## Product Specifications

**Table 22. 460V Heat Recovery Triple Modules I**

Model Name			4TVR0312B400NB	4TVR0336B400NB	4TVR0360B400NB				
			4TVR0072B400NB + 4TVR0096B400NB + 4TVR0144B400NB	4TVR0072B400NB + 4TVR0120B400NB + 4TVR0144B400NB	4TVR0072B400NB + 2x 4TVR0144B400NB				
Power Supply			460/60/3		460/60/3				
Nominal Tons			26.0		30.0				
System Type			Ducted	Non-Ducted	Ducted				
Performance	Capacity (Nominal) <sup>(a)</sup>	Cooling	Btuh	312,000	312,000	336,000	336,000	360,000	360,000
		Heating	Btuh	351,000	351,000	378,000	378,000	405,000	405,000
	Capacity (Rated) <sup>(b)</sup>	Cooling	Btuh	298,000	298,000	320,000	320,000	344,000	344,000
		High Temp Heating	Btuh	334,000	334,000	360,000	360,000	386,000	386,000
	AHRI -1230 Efficiency Ratings <sup>(b)</sup>	Low Temp Heating	Btuh	218,000	218,000	234,000	234,000	250,000	250,000
		EER	-	10.30	10.60	10.00	10.20	9.80	9.80
		IEER	-	18.10	20.90	17.00	20.50	16.60	20.00
		COP @ 47°F	-	3.20	3.38	3.20	3.27	3.20	3.22
	COP @ 17°F	-	2.25	2.51	2.21	2.39	2.11	2.31	
	SCHE	-	20.50	23.50	20.50	23.10	20.00	22.40	
Power	MCA	A	Each individual outdoor unit requires a separate electrical connection. Reference electrical data for each individual outdoor unit.						
	MOP	A							
	SCCR	kA							
Compressor	Type (Qty.)	-	SSC Scroll (4)		SSC Scroll (4)		SSC Scroll (5)		
	Model Name	-	DS-GB052FAVASG x 3 + DS-GB066FAVASG		DS-GB052FAVASG x 3 + DS-GB066FAVASG		DS-GB052FAVASG x 5		
	Output	kW	(4.96 x 3) + 6.13		(4.96 x 3) + 6.13		4.96 x 5		
	Oil	Type	-	PVE		PVE		PVE	
	Initial Charge	fl. oz.	311.1		311.1		388.9		
Fan	Type (Qty.)	-	Propeller (5)		Propeller (5)		Propeller (5)		
	Output (Each)	W	400 + 620 x 4		400 + 620 x 4		400 + 620 x 4		
	Airflow Rate	CFM	7,240 + 9,180 + 9,535		7,240 + 9,180 + 9,535		7,240 + (9,535 x 2)		
	External Static Pressure	in. WG	0.31		0.31		0.31		
Piping Connections	Liquid Pipe	Ø inch	3/4" Braze		3/4" Braze		3/4" Braze		
	Gas Pipe	Ø inch	1 3/8" Braze		1 3/8" Braze		1 5/8" Braze		
	High Pressure Gas Pipe (For HR)	Ø inch	1 1/8" Braze		1 1/8" Braze		1 3/8" Braze		
	Installation Limits	Max Length <sup>(c)</sup>	ft.	656 (722)		656 (722)		656 (722)	
Max Height <sup>(d)</sup>		ft.	361 (131)		361 (131)		361 (131)		
Indoor Unit Connections	Number Of Connectable Indoor Units	-	54		58		62		
	Total Capacity	-	50 to 130% of total outdoor unit capacity						
Refrigerant	Type	-	R-410A		R-410A		R-410A		
	Factory Charge	lbs.	47.6		47.6		50.5		
Sound <sup>(e)</sup>	Sound Pressure	dB(A)	-		-		-		
	Sound Power	dB(A)	-		-		-		
External Dimensions	Net Weight	lbs.	445 + 553 + 692		445 + 553 + 692		445 + (692 x 2)		
	Shipping Weight	lbs.	481 + 595 + 734		481 + 595 + 734		481 + (734 x 2)		
	Net Dimensions (WxHxD)	inches	34.65 x 66.73 x 30.12 + (50.98 x 66.73 x 30.12) x 2		34.65 x 66.73 x 30.12 + (50.98 x 66.73 x 30.12) x 2		34.65 x 66.73 x 30.12 + (50.98 x 66.73 x 30.12) x 2		
	Shipping Dimensions (WxHxD)	inches	37.32 x 75.28 x 32.76 + (53.66 x 75.28 x 32.76) x 2		37.32 x 75.28 x 32.76 + (53.66 x 75.28 x 32.76) x 2		37.32 x 75.28 x 32.76 + (53.66 x 75.28 x 32.76) x 2		
Operating Temp Range	Cooling <sup>(f)</sup>	°F	5 ~ 120		5 ~ 120		5 ~ 120		
	Heating	°F	-13 ~ 75		-13 ~ 75		-13 ~ 75		

**Note:** Requires two each 4TDK3819B0000A and 4TDK3100B0000A outdoor unit T-joint connections

- (a) Nominal capacity based on 25 ft. of equivalent refrigerant piping with 0 ft. level difference. Cooling: Indoor temperature 80°F DB, 67°F WB/Outdoor temperature 95°F DB, 75°F WB. Heating: Indoor temperature 70°F DB, 60°F WB/Outdoor temperature 47°F DB, 43°F WB.
- (b) Rated per AHRI-1230 Standard conditions (published ratings apply to systems < 300,000 Btuh).
- (c) Actual length (equivalent length in parenthesis).
- (d) If the outdoor unit is installed above the indoor units, the allowable height difference to the furthest indoor unit is 361 ft. If the outdoor unit is installed below the indoor units, the allowable height difference is 131 ft.
- (e) Sound pressure was acquired in a dead room. Actual noise level may be different depending on installation conditions.
- (f) Cooling operation between 23° F and 5° F requires mixed mode condition (at least 50% of the indoor units must be in heating mode).

**Table 23. 460V Heat Recovery Triple Modules II**

Model Name			4TVR0384B400NB	4TVR0408B400NB	4TVR0432B400NB				
			2x 4TVR0120B400NB + 4TVR0144B400NB	4TVR0120B400NB + 2x 4TVR0144B400NB	3x 4TVR0144B400NB				
Power Supply			460/60/3		460/60/3				
Performance	Nominal Tons		32.0		34.0	36.0			
	System Type		Ducted	Non-Ducted	Ducted	Non-Ducted			
	Capacity (Nominal) <sup>(a)</sup>	Cooling	Btuh	384,000	384,000	408,000	408,000	432,000	432,000
		Heating	Btuh	432,000	432,000	459,000	459,000	486,000	486,000
	Capacity (Rated) <sup>(b)</sup>	Cooling	Btuh	366,000	366,000	390,000	390,000	415,000	415,000
		High Temp Heating	Btuh	410,000	410,000	435,000	435,000	460,000	460,000
		Low Temp Heating	Btuh	268,000	268,000	284,000	284,000	300,000	300,000
	AHRI -1230 Efficiency Ratings <sup>(b)</sup>	EER	-	9.50	9.50	9.50	9.50	9.50	9.50
		IEER	-	16.20	19.50	16.30	19.10	16.30	19.10
		COP @ 47°F	-	3.20	3.20	3.20	3.20	3.20	3.20
COP @ 17°F		-	2.05	2.10	2.05	2.05	2.05	2.05	
	SCHE	-	19.50	23.00	19.00	22.00	19.00	21.50	
Power	MCA	A	Each individual outdoor unit requires a separate electrical connection. Reference electrical data for each individual outdoor unit.						
	MOP	A							
	SCCR	kA							
Compressor	Type (Qty.)		SSC Scroll (4)		SSC Scroll (5)	SSC Scroll (6)			
	Model Name		DS-GB052FAVASG x 2 + DS-GB066FAVASG x 2		DS-GB052FAVASG x 4 + DS-GB066FAVASG	DS-GB052FAVASG x 6			
	Output		kW		(4.96 x 2) + (6.13 x 2)	(4.96 x 4) + 6.13	4.96 x 6		
	Oil	Type	-	PVE		PVE	PVE		
Initial Charge		fl. oz.	311.1		388.9	466.6			
Fan	Type (Qty.)		Propeller (6)		Propeller (6)	Propeller (6)			
	Output (Each)		W		620 x 6	620 x 6			
	Airflow Rate		CFM		(9,180 x 2) + 9535	9,180 + (2x 9,535)	9535 x 3		
	External Static Pressure		in. WG		0.31	0.31	0.31		
Piping Connections	Liquid Pipe		Ø inch		3/4" Braze	3/4" Braze			
	Gas Pipe		Ø inch		1 5/8" Braze	1 5/8" Braze			
	High Pressure Gas Pipe (For HR)		Ø inch		1 3/8" Braze	1 3/8" Braze			
	Installation Limits	Max Length <sup>(c)</sup>	ft.	656 (722)		656 (722)	656 (722)		
		Max Height <sup>(d)</sup>	ft.	361 (131)		361 (131)	361 (131)		
Indoor Unit Connections	Number Of Connectable Indoor Units		-		64	64			
	Total Capacity		-		50 to 130% of total outdoor unit capacity				
Refrigerant	Type		-		R-410A	R-410A			
	Factory Charge		lbs.		51.8	54.7	57.5		
Sound <sup>(e)</sup>	Sound Pressure		dB(A)		-	-			
	Sound Power		dB(A)		-	-			
External Dimensions	Net Weight		lbs.		553 + (692 x 2)	553 + (692 x 2)	692 x 3		
	Shipping Weight		lbs.		595 + (734 x 2)	595 + (734 x 2)	734 x 3		
	Net Dimensions (WxHxD)		inches		(50.98 x 66.73 x 30.12) x 3	(50.98 x 66.73 x 30.12) x 3	(50.98 x 66.73 x 30.12) x 3		
	Shipping Dimensions (WxHxD)		inches		(53.66 x 75.28 x 32.76) x 3	(53.66 x 75.28 x 32.76) x 3	(53.66 x 75.28 x 32.76) x 3		
Operating Temp Range	Cooling <sup>(f)</sup>		°F		5 ~ 120	5 ~ 120	5 ~ 120		
	Heating		°F		-13 ~ 75	-13 ~ 75	-13 ~ 75		

**Note:** Requires two each 4TDK3819B0000A and 4TDK3100B0000A outdoor unit T-joint connections

(a) Nominal capacity based on 25 ft. of equivalent refrigerant piping with 0 ft. level difference. Cooling: Indoor temperature 80°F DB, 67°F WB/Outdoor temperature 95°F DB, 75°F WB. Heating: Indoor temperature 70°F DB, 60°F WB/Outdoor temperature 47°F DB, 43°F WB.

(b) Rated per AHRI-1230 Standard conditions.

(c) Actual length (equivalent length in parenthesis).

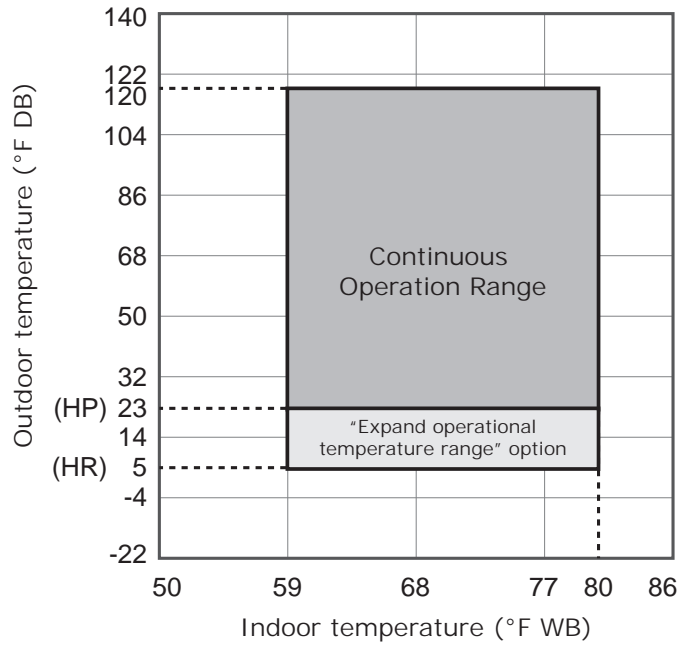
(d) If the outdoor unit is installed above the indoor units, the allowable height difference to the furthest indoor unit is 361 ft. If the outdoor unit is installed below the indoor units, the allowable height difference is 131 ft.

(e) Sound pressure was acquired in a dead room. Actual noise level may be different depending on installation conditions.

(f) Cooling operation between 23° F and 5° F requires mixed mode condition (at least 50% of the indoor units must be in heating mode).

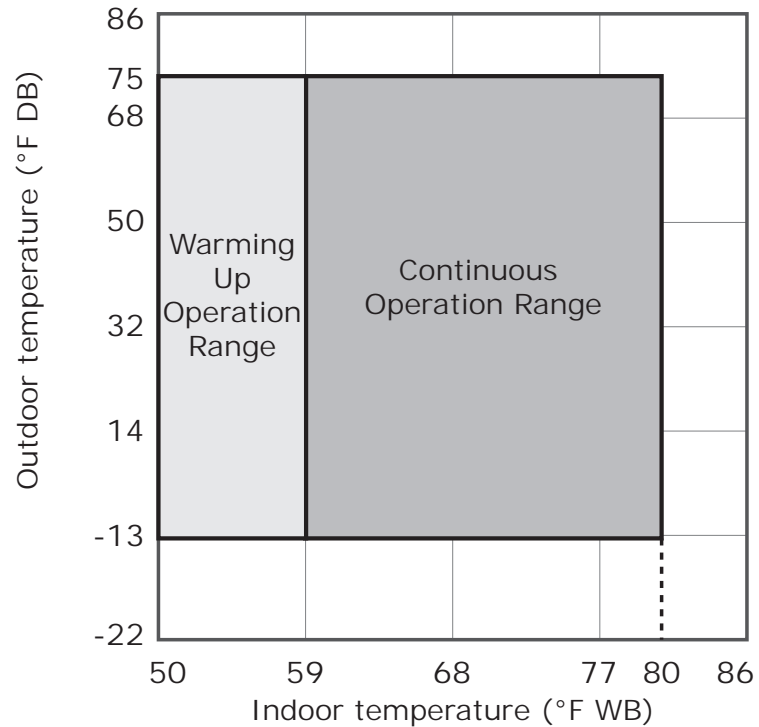
# Operation Limit - Outdoor Units

**Figure 1. Cooling<sup>(a)</sup>**



(a)Extend operational temperature range applies to heat recovery systems in mixed mode condition (at least 50% of the indoor units must be in heating mode).

**Figure 2. Heating**

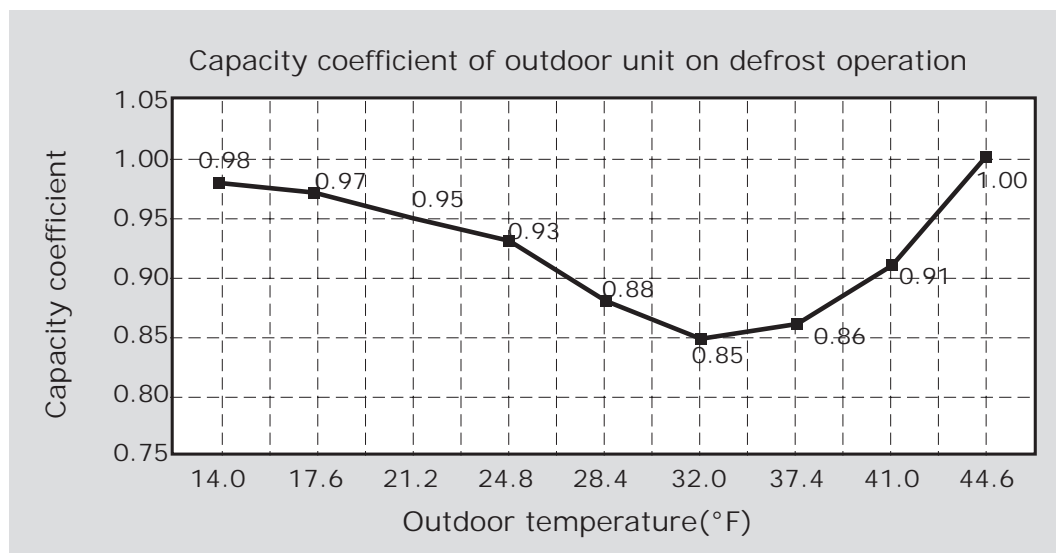


## Defrosting Correction Factor

In heating operation, frost can be formed on heat exchanger according to outdoor temperature. (frost on heat exchanger results in decreasing the performance.) To remove frost on heat exchanger of outdoor unit, defrost operation is carried out periodically. During defrost operation, capacity of outdoor unit may decrease. The decrement is not considered to the individual capacity tables.

Outdoor temperature (°F, WB)	14.0	17.6	21.2	24.8	28.4	32.0	37.4	41.0	44.6
Capacity coefficient	0.98	0.97	0.95	0.93	0.88	0.85	0.86	0.91	1.00

**Figure 3. Corrected Heating Capacity = Heating Capacity x Capacity coefficient**

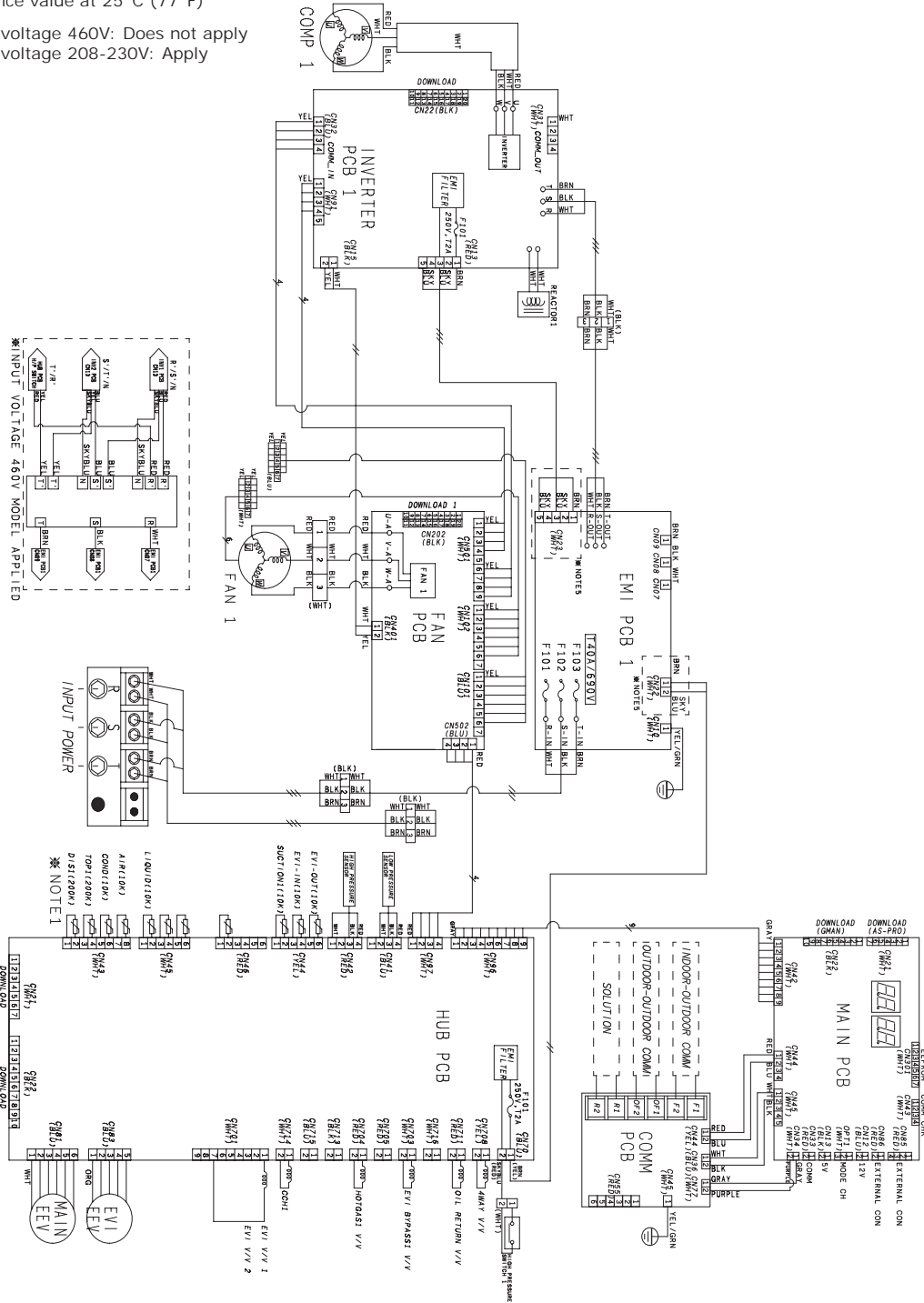


# Electrical Wiring Diagrams - Outdoor Units

**Figure 4. Heat Pump - 4TVH0072B300NB, 4TVH0072B400NB**

Note 1: Resistance value at 25°C (77°F)

Note 5: Input voltage 460V: Does not apply  
Input voltage 208-230V: Apply

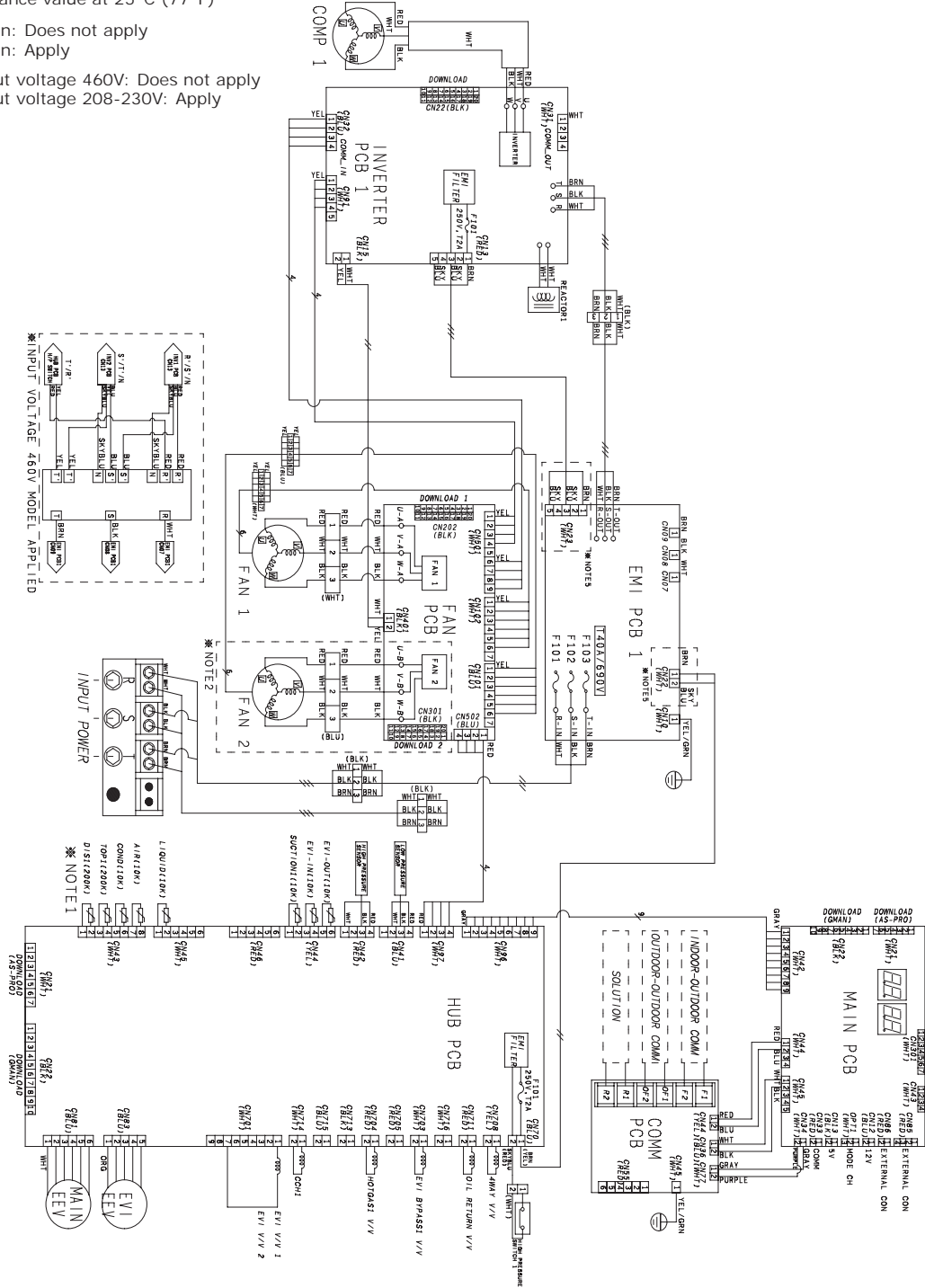




# Electrical Wiring Diagrams - Outdoor Units

**Figure 5. Heat Pump - 4TVH0096B400NB, 4TVH0120B400NB**

- Note 1: Resistance value at 25°C (77°F)
- Note 2: 1 Fan: Does not apply  
2 Fan: Apply
- Note 5: Input voltage 460V: Does not apply  
Input voltage 208-230V: Apply



# Electrical Wiring Diagrams - Outdoor Units

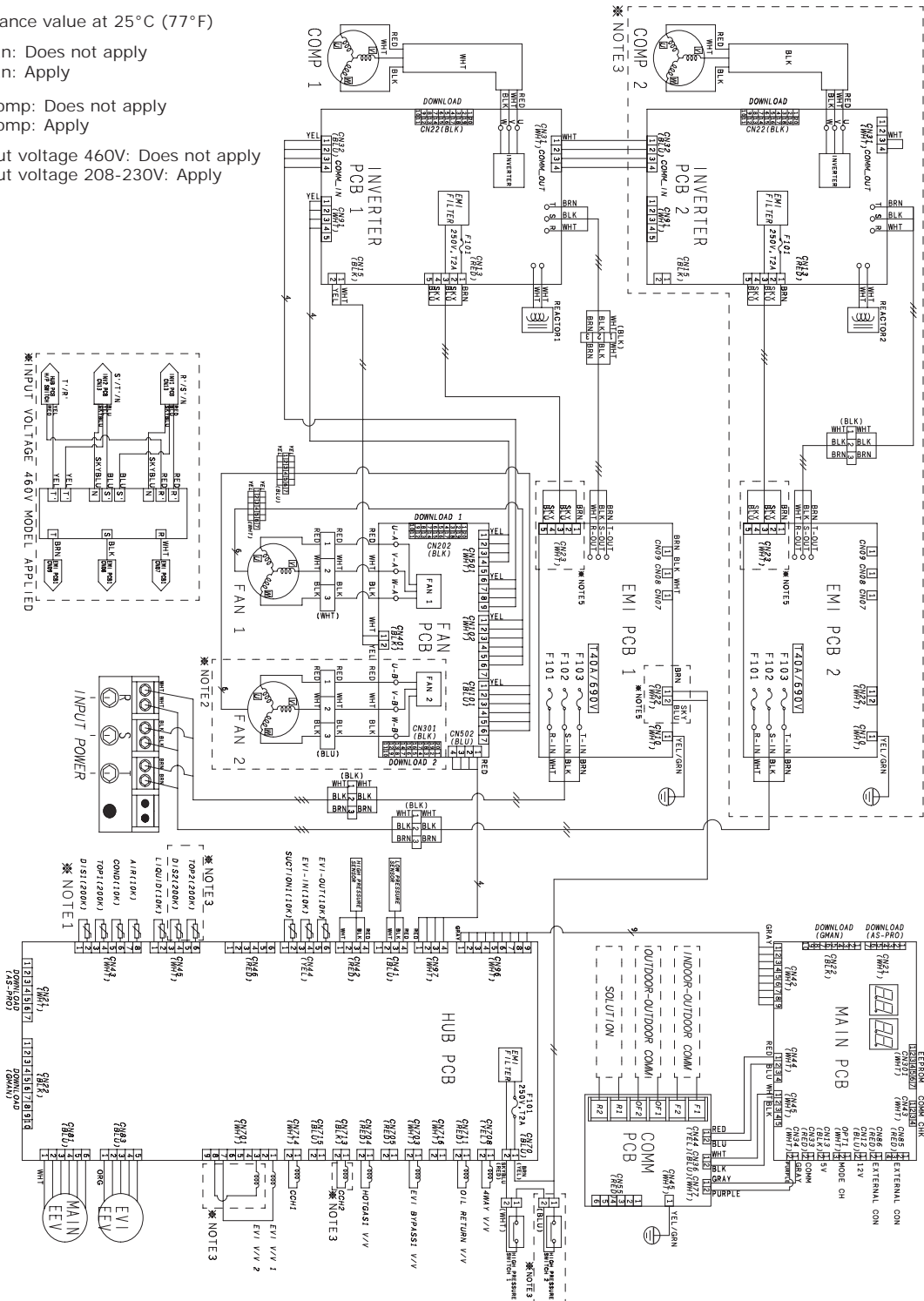
**Figure 6. Heat Pump - 4TVH0096B300NB, 4TVH0120B300NB, 4TVH0144B300NB, 4TVH0144B400NB**

Note 1: Resistance value at 25°C (77°F)

Note 2: 1 Fan: Does not apply  
2 Fan: Apply

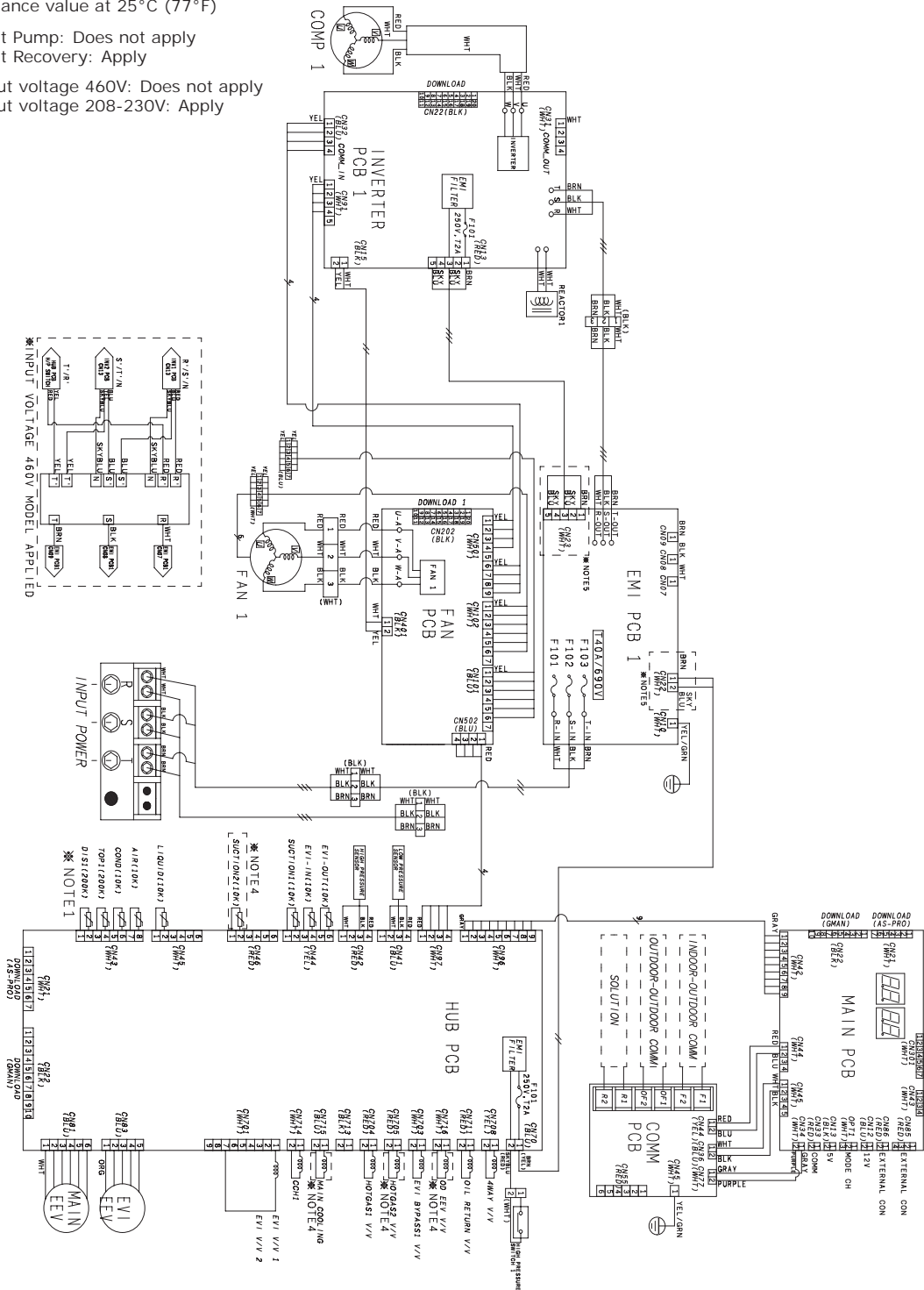
Note 3: 1 Comp: Does not apply  
2 Comp: Apply

Note 5: Input voltage 460V: Does not apply  
Input voltage 208-230V: Apply



**Figure 7. Heat Recovery - 4TVR0072B300NB, 4TVR0072B400NB**

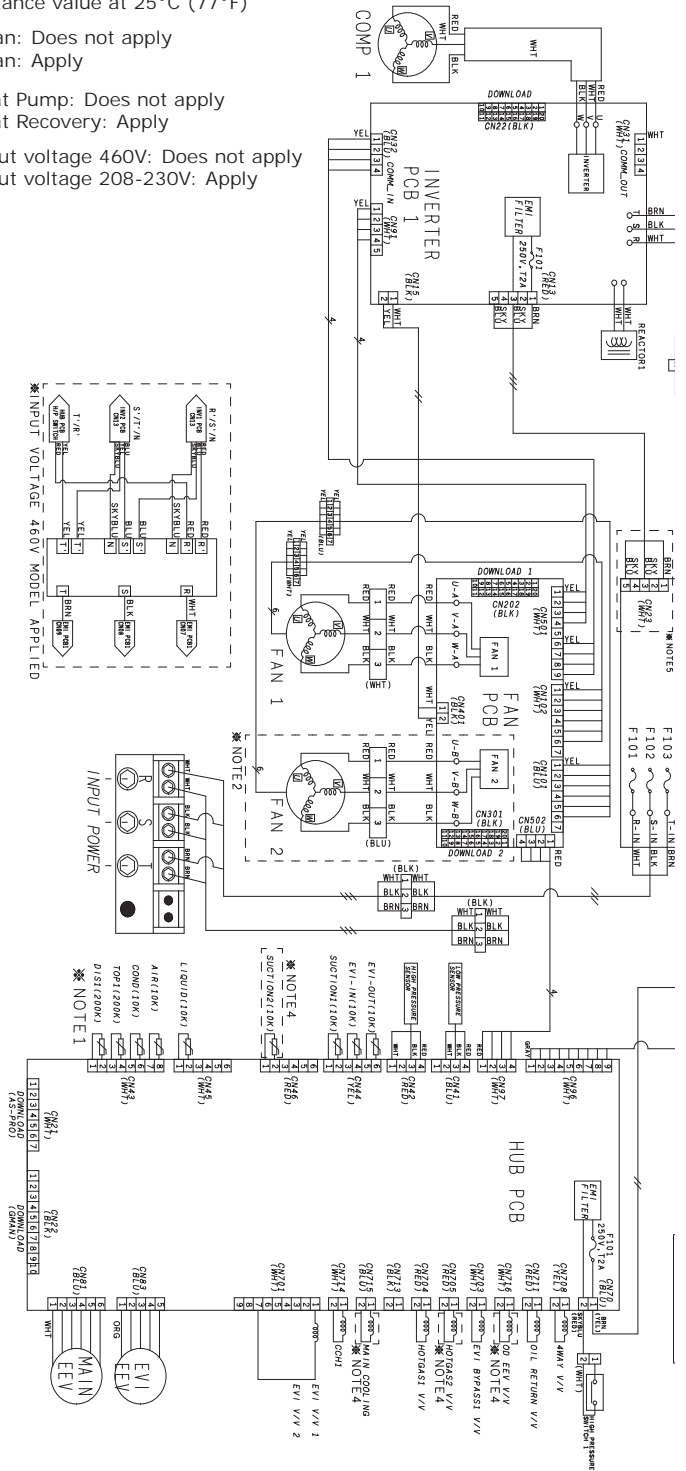
- Note 1: Resistance value at 25°C (77°F)
- Note 4: Heat Pump: Does not apply  
Heat Recovery: Apply
- Note 5: Input voltage 460V: Does not apply  
Input voltage 208-230V: Apply



# Electrical Wiring Diagrams - Outdoor Units

**Figure 8. Heat Recovery - 4TVR0096B400NB, 4TVR0120B400NB**

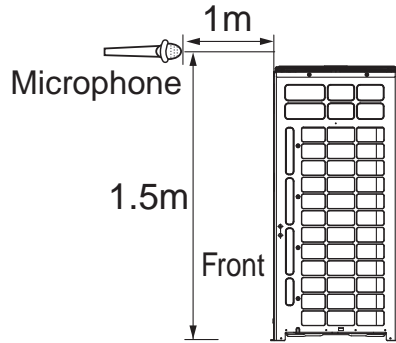
- Note 1: Resistance value at 25°C (77°F)
- Note 2: 1 Fan: Does not apply  
2 Fan: Apply
- Note 4: Heat Pump: Does not apply  
Heat Recovery: Apply
- Note 5: Input voltage 460V: Does not apply  
Input voltage 208-230V: Apply





# Sound Levels - Outdoor Units

**Figure 10. Sound Pressure Level**



Unit: dB(A)

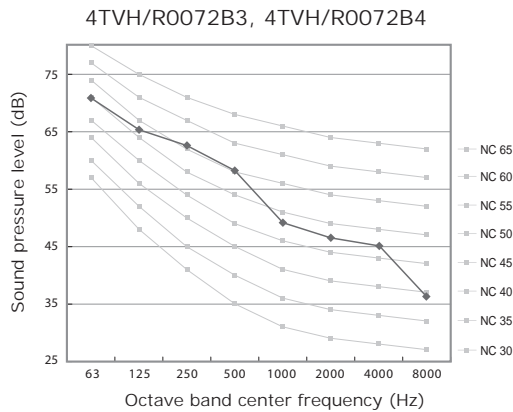
Model	Pressure
4TVH/R0072B3, 4TVH/R0072B4	60
4TVH/R0096B3, 4TVH/R0120B3	61
4TVH/R0096B4, 4TVH/R0120B4	61
4TVH/R0072B3, 4TVH/R0072B4	60

**Notes:**

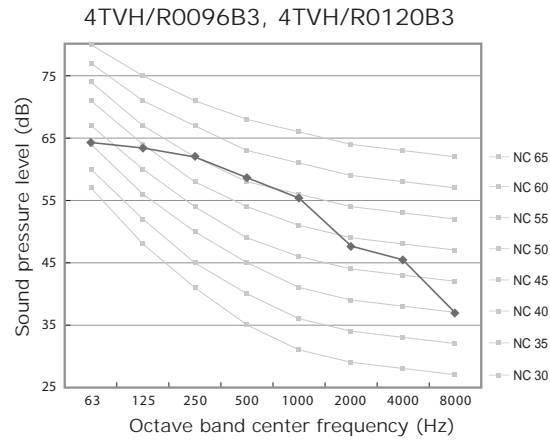
- *Measuring place: Anechoic chamber (conversion value)*
- *These operation values were obtained in an anechoic room. Sound pressure level will vary depending on a range of factors such as the construction of the particular room where the equipment is installed.*
- *Operation sound level may differ depending on operation and ambient conditions.*

## NC Curves

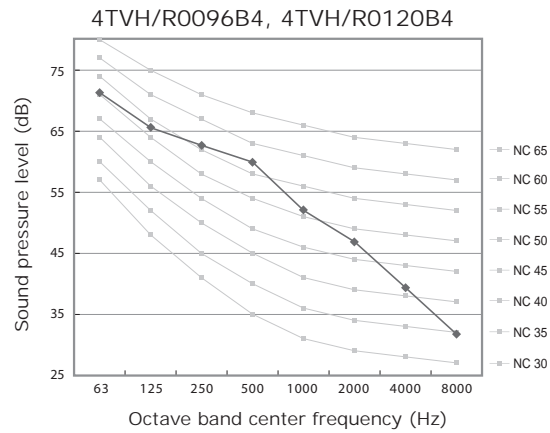
**Figure 11. 4TVH/R0072B3, 4TVH/R0072B4**



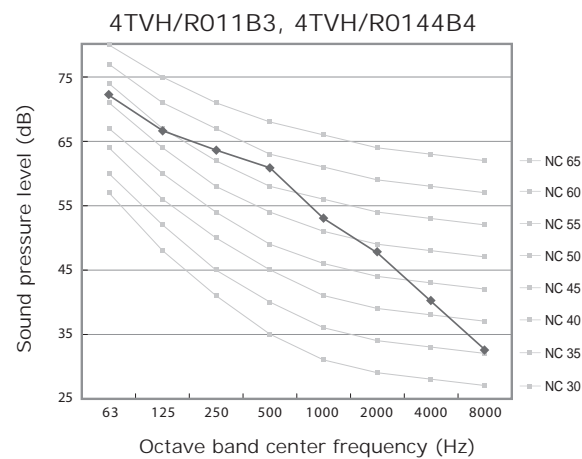
**Figure 12. 4TVH/R0096B3, 4TVH/R0120B3**



**Figure 13. 4TVH/R0096B4, 4TVH/R0120B4**



**Figure 14. 4TVH/R0144B3, 4TVH/R0144B4**



## Sound Power

**Notes:**

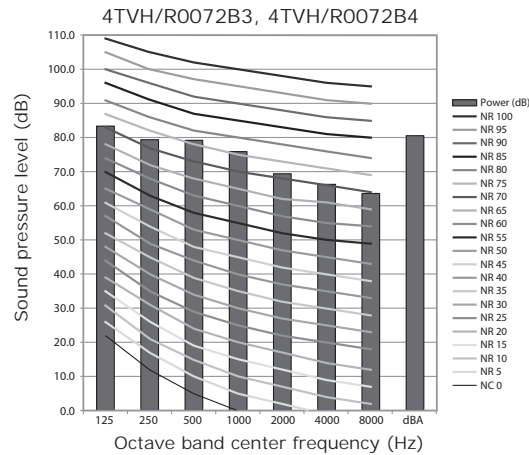
- dBA = A-weighted sound power level.
- Reference power: 1pW
- Measured according to ISO 3741.

Unit: dB(A)

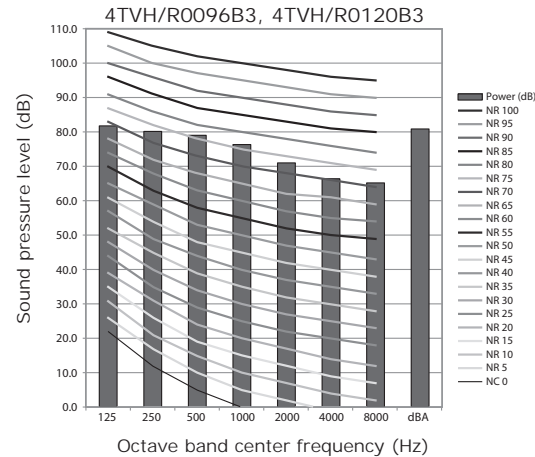
Model	Power
4TVH/R0072B3, 4TVH/R0072B4	81
4TVH/R0096B3, 4TVH/R0120B3	81
4TVH/R0096B4, 4TVH/R0120B4	81
4TVH/R0144B3, 4TVH/R0144B4	83

## NR Curves

**Figure 15. 4TVH/R0072B3, 4TVH/R0072B4**

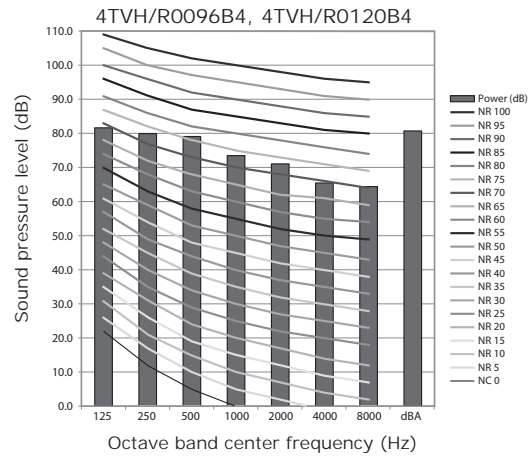


**Figure 16. 4TVH/R0096B3, 4TVH/R0120B3**

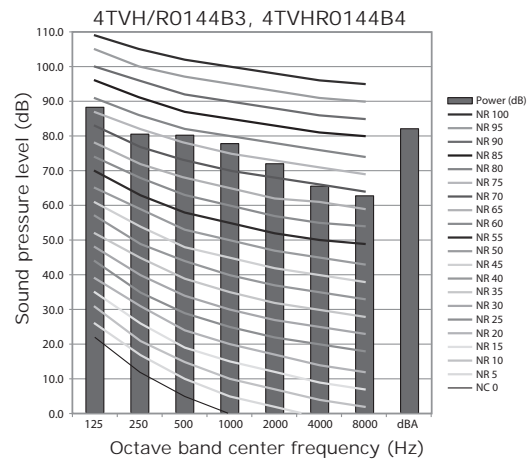




**Figure 17. 4TVH/R0096B4, 4TVH/R0120B4**



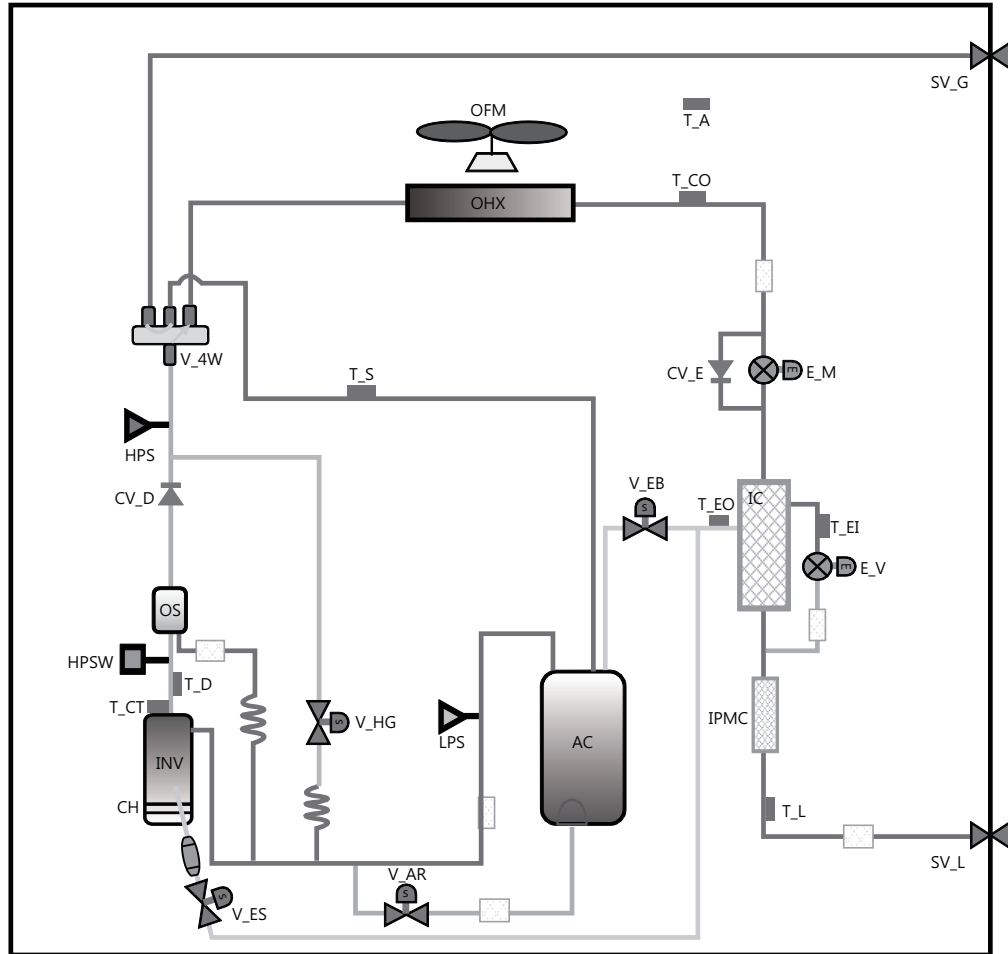
**Figure 18. 4TVH/R0144B3, 4TVH/R0144B4**



# Cycle Diagrams

## Parts of Outdoor Unit (HP)

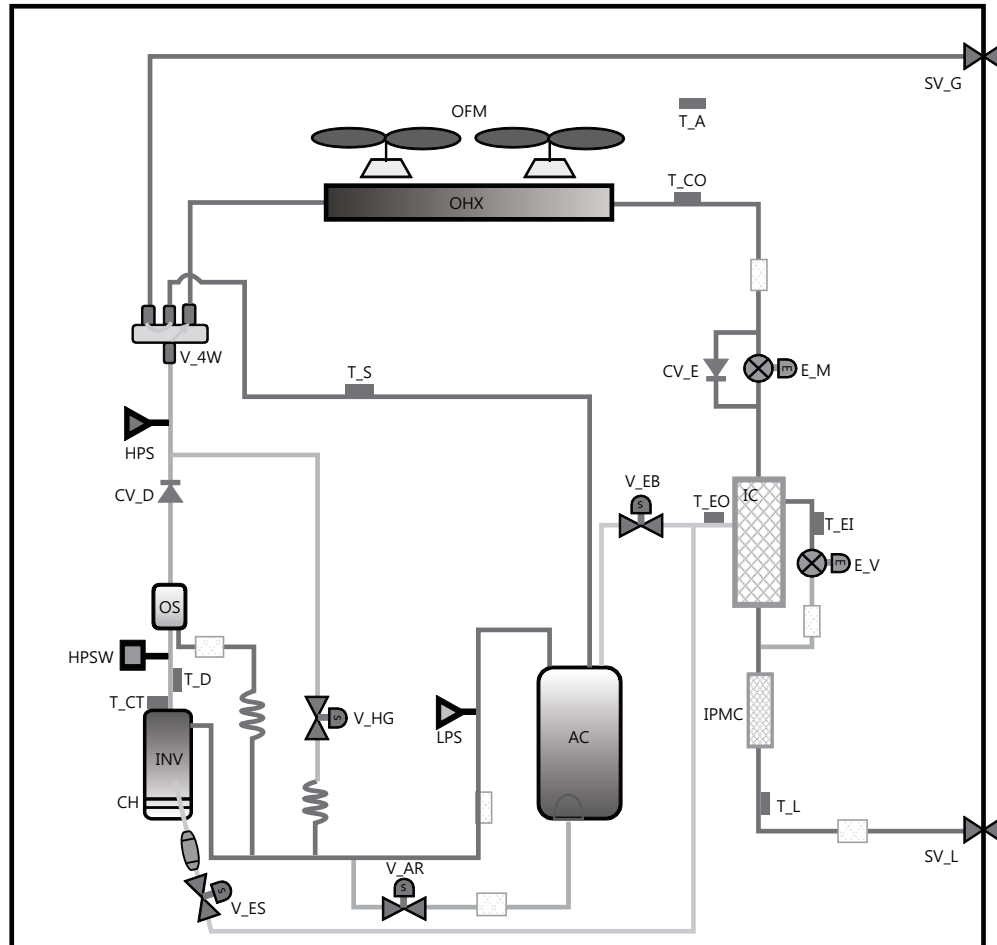
Figure 19. 4TVH0072B300NB, 4TVH0072B400NB



Classification	Description
INV	Inverter Compressor
OFM	Outdoor Fan Motor
OHX	Outdoor Heat Exchanger
AC	Accumulator
OS	Oil Separator
IC	Intercooler
IPMC	IPM Cooler
CH	Crank Case Heater
HPS	High Pressure Sensor
LPS	Low Pressure Sensor
HPSW	High Pressure Switch
E_M	Main EEV
E_EV	EVI EEV
V_ES	EVI Solenoid Valve
V_EB	EVI Bypass Valve

Classification	Description
V_HG	Hot Gas Bypass Valve
V_4W	4way Valve
V_AR	Accumulator Oil Return Valve
CV_E	EEV Bypass Check Valve
CV_D	Discharge Check Valve
T_D	Discharge Temperature Sensor
T_S	Suction Temperature Sensor
T_CO	Condenser Out Temperature Sensor
T_EI	EVI In Temperature Sensor
T_EO	EVI Out Temperature Sensor
T_L	Liquid Tube Temperature Sensor
T_CT	Compressor Top Temperature Sensor
T_A	Ambient Temperature Sensor
SV_G	Gas Pipe Service Valve
SV_L	Liquid Pipe Service Valve

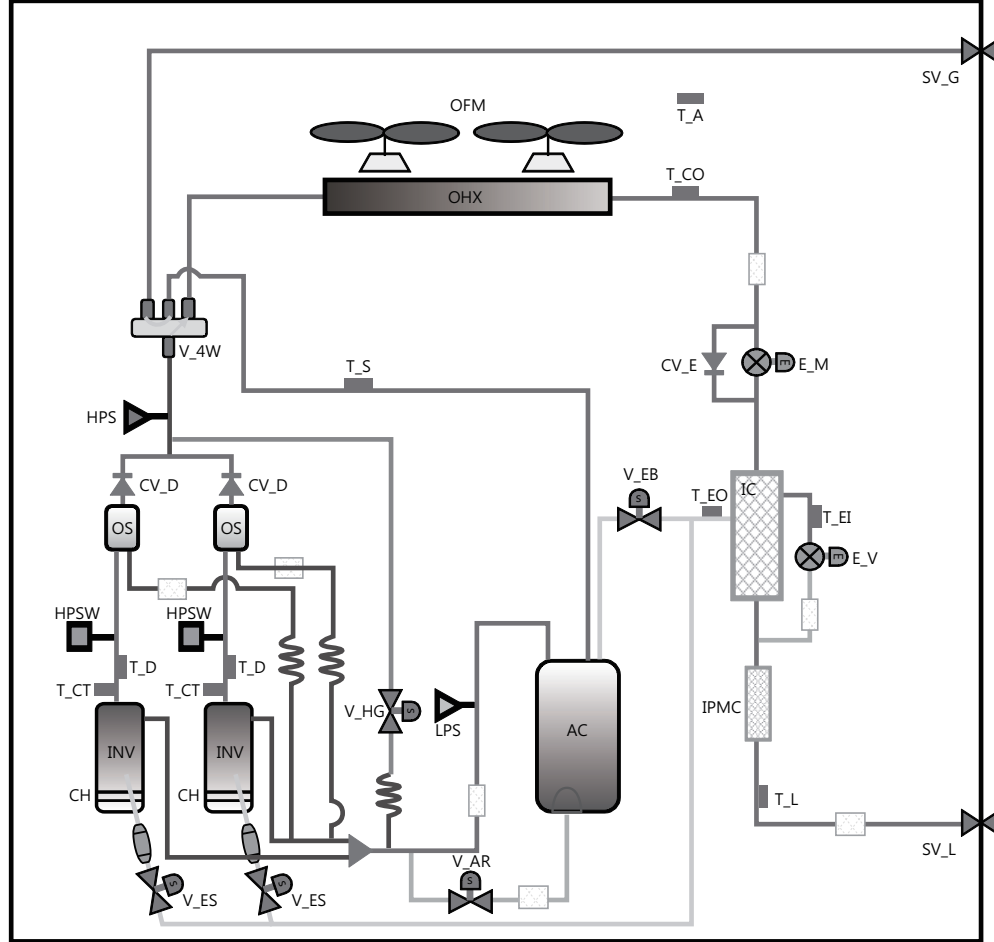
**Figure 20. 4TVH0096B400NB, 4TVH0120B400NB**



Classification	Description
INV	Inverter Compressor
OFM	Outdoor Fan Motor
OHX	Outdoor Heat Exchanger
AC	Accumulator
OS	Oil Separator
IC	Intercooler
IPMC	IPM Cooler
CH	Crank Case Heater
HPS	High Pressure Sensor
LPS	Low Pressure Sensor
HPSW	High Pressure Switch
E_M	Main EEV
E_EV	EVI EEV
V_ES	EVI Solenoid Valve
V_EB	EVI Bypass Valve

Classification	Description
V_HG	Hot Gas Bypass Valve
V_4W	4way Valve
V_AR	Accumulator Oil Return Valve
CV_E	EEV Bypass Check Valve
CV_D	Discharge Check Valve
T_D	Discharge Temperature Sensor
T_S	Suction Temperature Sensor
T_CO	Condenser Out Temperature Sensor
T_EI	EVI In Temperature Sensor
T_EO	EVI Out Temperature Sensor
T_L	Liquid Tube Temperature Sensor
T_CT	Compressor Top Temperature Sensor
T_A	Ambient Temperature Sensor
SV_G	Gas Pipe Service Valve
SV_L	Liquid Pipe Service Valve

**Figure 21. 4TVH0096B300NB, 4TVH0120B300NB, 4TVH0144B300NB, 4TVH0144B400NB**

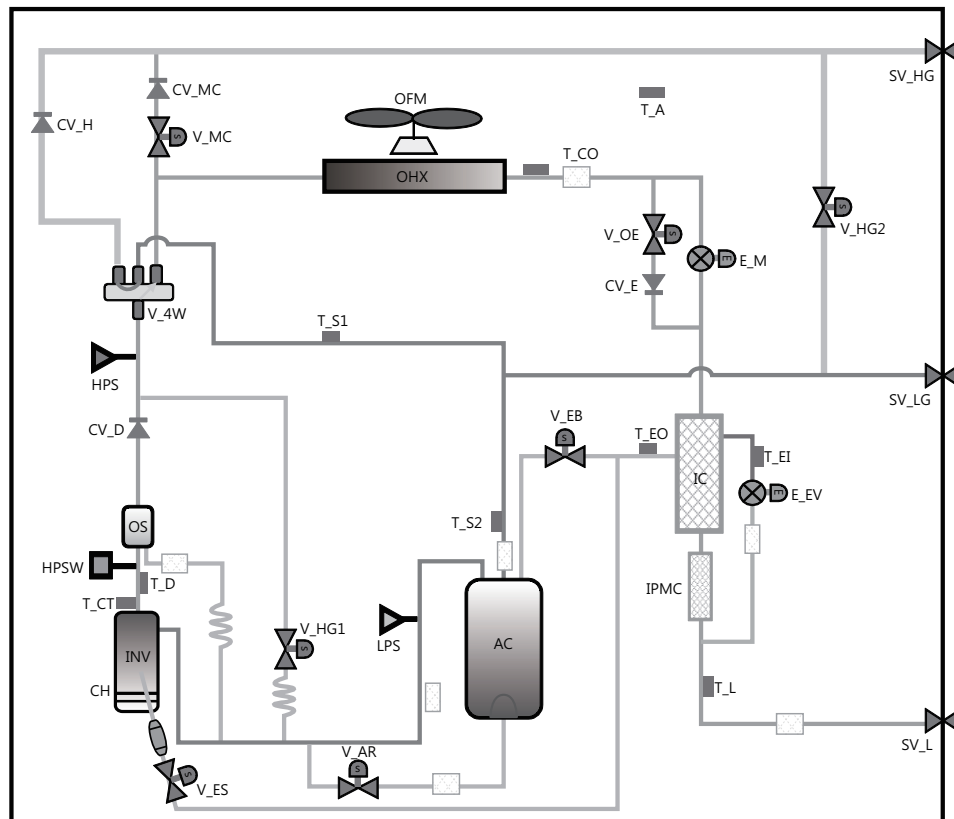


Classification	Description
INV	Inverter Compressor
OFM	Outdoor Fan Motor
OHX	Outdoor Heat Exchanger
AC	Accumulator
OS	Oil Separator
IC	Intercooler
IPMC	IPM Cooler
CH	Crank Case Heater
HPS	High Pressure Sensor
LPS	Low Pressure Sensor
HPSW	High Pressure Switch
E_M	Main EEV
E_EV	EVI EEV
V_ES	EVI Solenoid Valve
V_EB	EVI Bypass Valve

Classification	Description
V_HG	Hot Gas Bypass Valve
V_4W	4way Valve
V_AR	Accumulator Oil Return Valve
CV_E	EEV Bypass Check Valve
CV_D	Discharge Check Valve
T_D	Discharge Temperature Sensor
T_S	Suction Temperature Sensor
T_CO	Condenser Out Temperature Sensor
T_EI	EVI In Temperature Sensor
T_EO	EVI Out Temperature Sensor
T_L	Liquid Tube Temperature Sensor
T_CT	Compressor Top Temperature Sensor
T_A	Ambient Temperature Sensor
SV_G	Gas Pipe Service Valve
SV_L	Liquid Pipe Service Valve

## Parts of Outdoor Unit (HR)

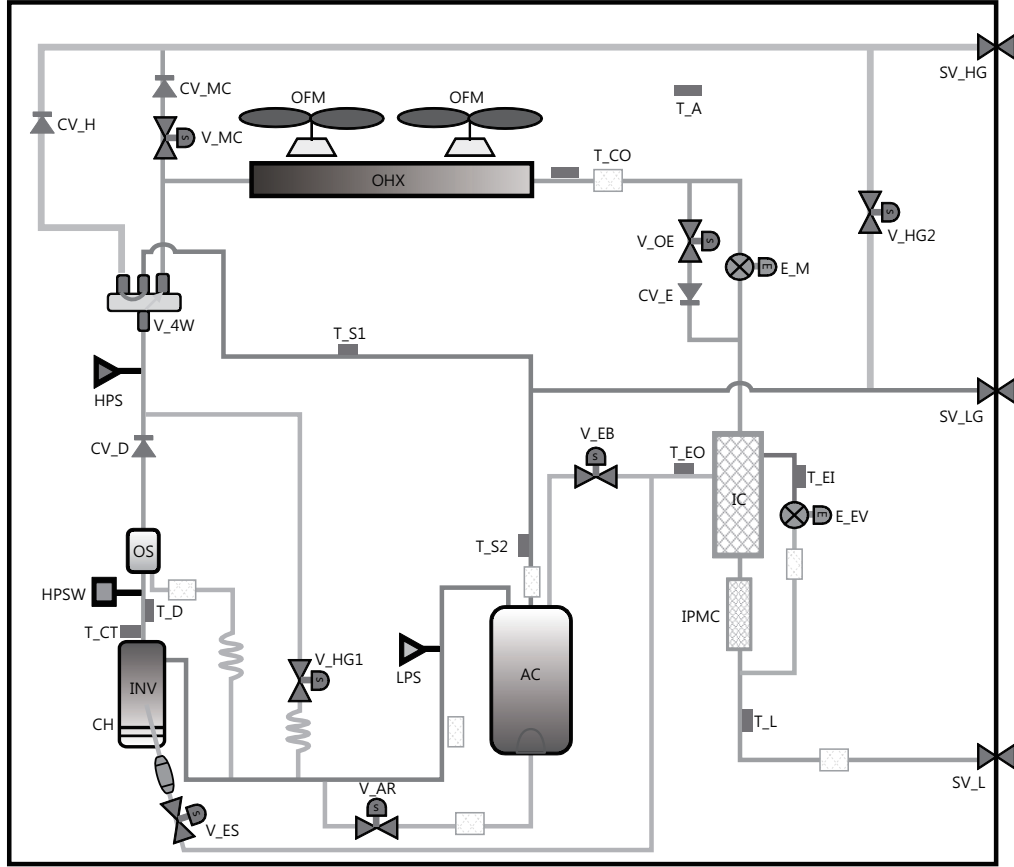
Figure 22. 4TVR0072B300NB, 4TVR0072B400NB



Classification	Description
INV	Inverter Compressor
OFM	Outdoor Fan Motor
OHX	Outdoor Heat Exchanger
AC	Accumulator
OS	Oil Separator
IC	Intercooler
IPMC	IPM Cooler
CH	Crank Case Heater
HPS	High Pressure Sensor
LPS	Low Pressure Sensor
HPSW	High Pressure Switch
E_M	Main EEV
E_EV	EVI EEV
V_ES	EVI Solenoid Valve
V_EB	EVI Bypass Valve

Classification	Description
V_HG	Hot Gas Bypass Valve
V_4W	4way Valve
V_AR	Accumulator Oil Return Valve
CV_E	EEV Bypass Check Valve
CV_D	Discharge Check Valve
T_D	Discharge Temperature Sensor
T_S	Suction Temperature Sensor
T_CO	Condenser Out Temperature Sensor
T_EI	EVI In Temperature Sensor
T_EO	EVI Out Temperature Sensor
T_L	Liquid Tube Temperature Sensor
T_CT	Compressor Top Temperature Sensor
T_A	Ambient Temperature Sensor
SV_G	Gas Pipe Service Valve
SV_L	Liquid Pipe Service Valve

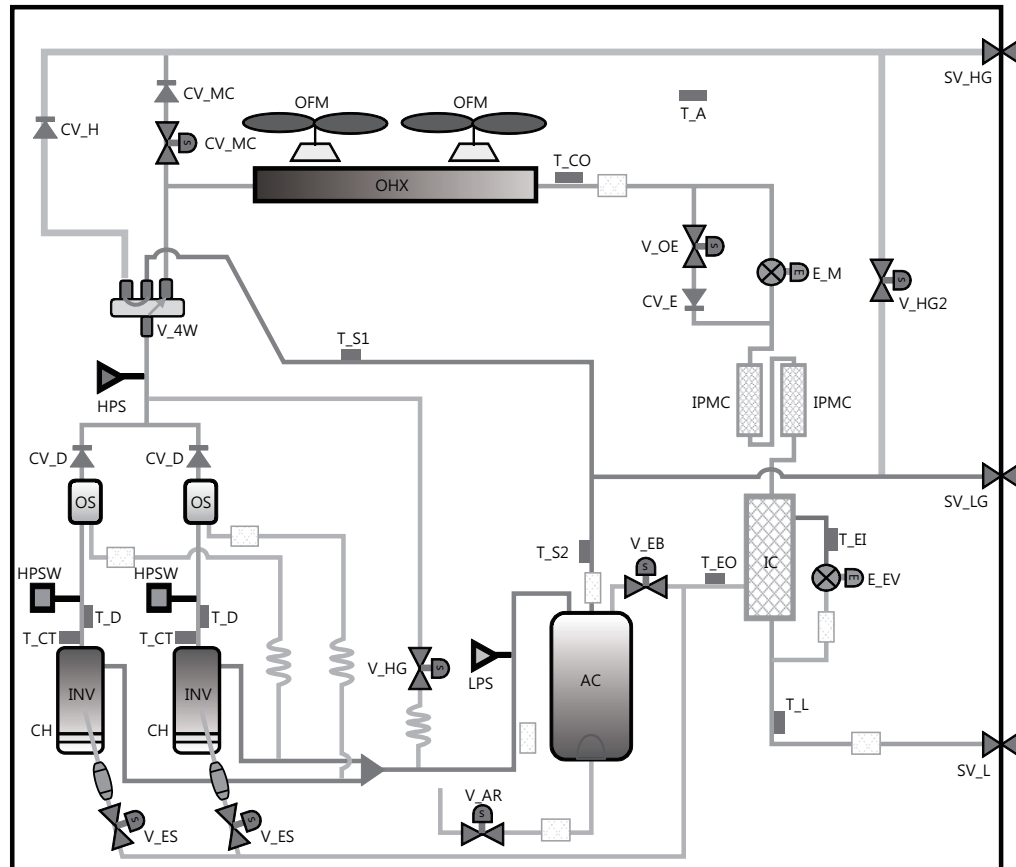
**Figure 23. 4TVR0096B400NB, 4TVR0120B400NB**



Classification	Description
INV	Inverter Compressor
OFM	Outdoor Fan Motor
OHX	Outdoor Heat Exchanger
AC	Accumulator
OS	Oil Separator
IC	Intercooler
IPMC	IPM Cooler
CH	Crank Case Heater
HPS	High Pressure Sensor
LPS	Low Pressure Sensor
HPSW	High Pressure Switch
E_M	Main EEV
E_EV	EVI EEV
V_ES	EVI Solenoid Valve
V_EB	EVI Bypass Valve

Classification	Description
V_HG	Hot Gas Bypass Valve
V_4W	4way Valve
V_AR	Accumulator Oil Return Valve
CV_E	EEV Bypass Check Valve
CV_D	Discharge Check Valve
T_D	Discharge Temperature Sensor
T_S	Suction Temperature Sensor
T_CO	Condenser Out Temperature Sensor
T_EI	EVI In Temperature Sensor
T_EO	EVI Out Temperature Sensor
T_L	Liquid Tube Temperature Sensor
T_CT	Compressor Top Temperature Sensor
T_A	Ambient Temperature Sensor
SV_G	Gas Pipe Service Valve
SV_L	Liquid Pipe Service Valve

**Figure 24. 4TVR0096B300NB, 4TVR0120B300NB, 4TVR0144B300NB, 4TVR0144B400NB**



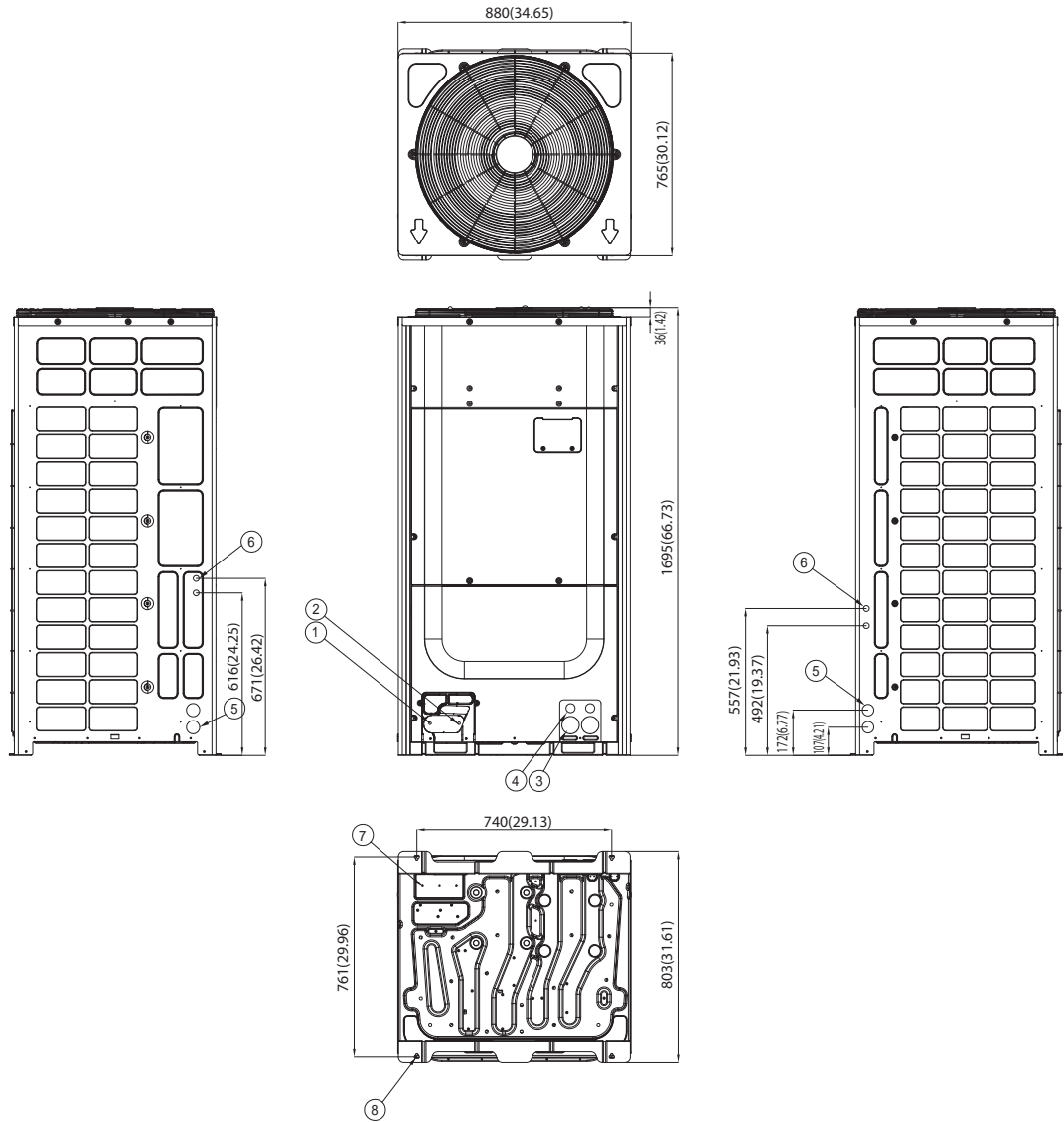
Classification	Description
INV	Inverter Compressor
OFM	Outdoor Fan Motor
OHX	Outdoor Heat Exchanger
AC	Accumulator
OS	Oil Separator
IC	Intercooler
IPMC	IPM Cooler
CH	Crank Case Heater
HPS	High Pressure Sensor
LPS	Low Pressure Sensor
HPSW	High Pressure Switch
E_M	Main EEV
E_EV	EVI EEV
V_ES	EVI Solenoid Valve
V_EB	EVI Bypass Valve

Classification	Description
V_HG	Hot Gas Bypass Valve
V_4W	4way Valve
V_AR	Accumulator Oil Return Valve
CV_E	EEV Bypass Check Valve
CV_D	Discharge Check Valve
T_D	Discharge Temperature Sensor
T_S	Suction Temperature Sensor
T_CO	Condenser Out Temperature Sensor
T_EI	EVI In Temperature Sensor
T_EO	EVI Out Temperature Sensor
T_L	Liquid Tube Temperature Sensor
T_CT	Compressor Top Temperature Sensor
T_A	Ambient Temperature Sensor
SV_G	Gas Pipe Service Valve
SV_L	Liquid Pipe Service Valve

# Dimensional Drawings

## Heat Pump/Heat Recovery

Figure 25. 4TVH/R0072B\*\*\*\*\*(a)

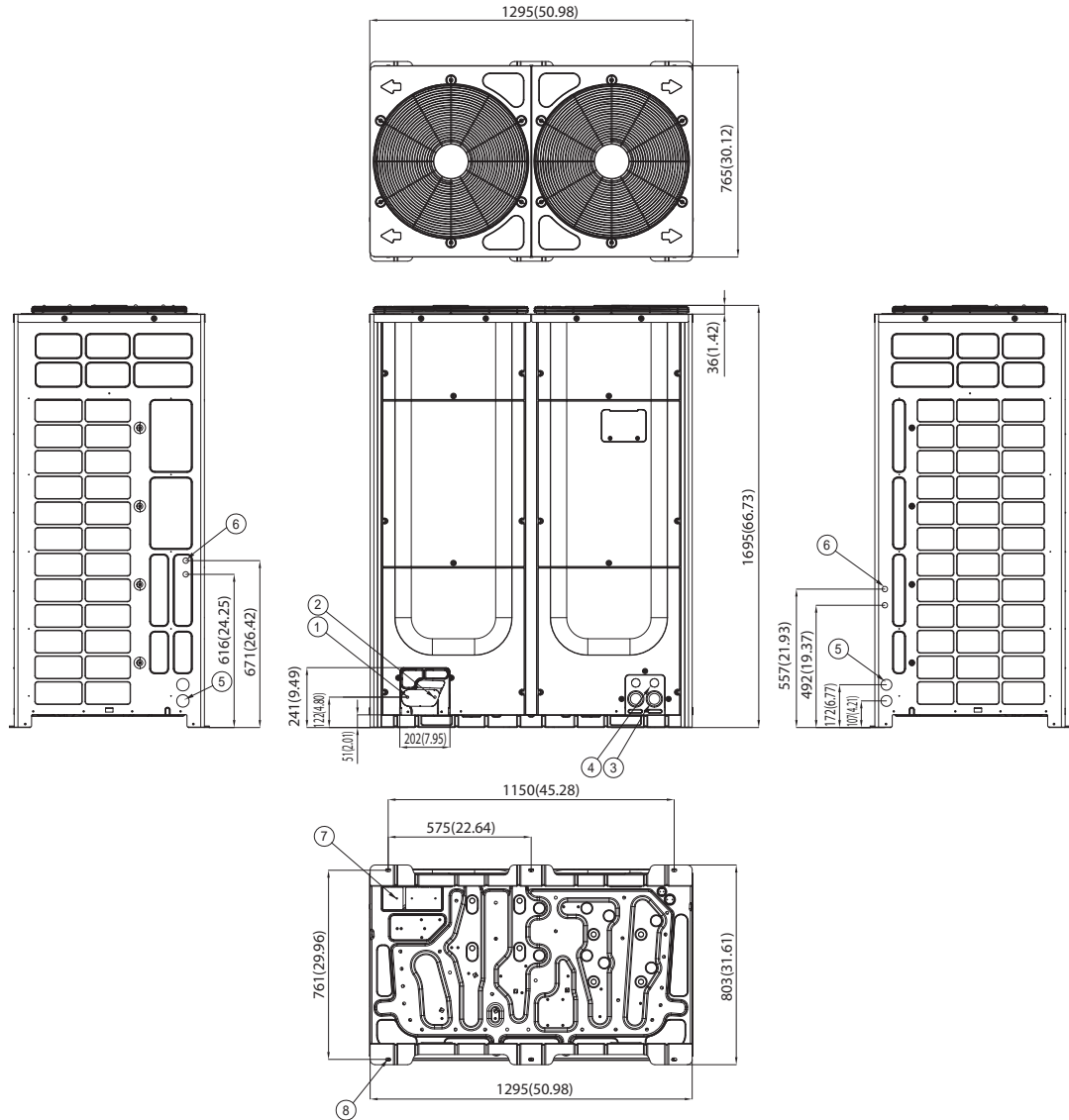


(a) Unit: mm (inch)

No.	Name	Description	No.	Name	Description
1	Gas Ref. Pipe	-	5	Power Wiring Conduit	4(0.16") - Ø43.7(1.72")
2	Liquid Ref. Pipe	-	6	Communication Wiring Conduit	8(0.31") - Ø22.0(0.87")
3	Power Wiring Conduit	2(0.08") - Ø43.7(1.72")	7	Knock-out Hole for Ref. Piping	178 x 76(7" x 3")
4	Communication Wiring Conduit	2(0.08") - Ø34.5(1.36")	8	Anchor Bolt Hole	4(0.16") - Ø12(0.47")



**Figure 26. 4TVH/R0096B\*\*\*\*, 4TVH/R120B\*\*\*\*, 4TVH/R0144B\*\*\*\*(a)**



(a) Unit: mm (inch)

No.	Name	Description	No.	Name	Description
1	Gas Ref. Pipe	-	5	Power Wiring Conduit	4(0.16") - Ø43.7(1.72")
2	Liquid Ref. Pipe	-	6	Communication Wiring Conduit	8(0.31") - Ø22.0(0.87")
3	Power Wiring Conduit	2(0.08") - Ø43.7(1.72")	7	Knock-out Hole for Ref. Piping	178 x 76(7" x 3")
4	Communication Wiring Conduit	2(0.08") - Ø34.5(1.36")	8	Anchor Bolt Hole	4(0.16") - Ø12(0.47")







Trane optimizes the performance of homes and buildings around the world. A business of Ingersoll Rand, the leader in creating and sustaining safe, comfortable and energy efficient environments, Trane offers a broad portfolio of advanced controls and HVAC systems, comprehensive building services, and parts. For more information, visit [www.Trane.com](http://www.Trane.com).

Trane has a policy of continuous product and product data improvement and reserves the right to change design and specifications without notice.