



APTA BTS-BC-RP-006-17

Published: January 26, 2017
APTA Bus Brake Working Group

Transit Bus Air Disc Brake Operation and Wheels-On Inspection

Abstract: This document establishes a recommended practice for wheels-on transit bus front/rear axle pneumatic disc brake inspection. Individual operating agencies should modify these guidelines to accommodate their specific equipment and mode of operation.

Keywords: ABS tone ring, boot, bridge, bushing, caliper, carrier, disc, disc brake maintenance, hub, pads, pin, rotor, potentiometers, retaining strap, seal, slide pins, spring clips wheel seals, torque plate, wear indicator, wear sensors

Summary: This *Recommended Practice* provides guidelines for performing wheels-on brake maintenance on a bus with air disc brakes, including inspection and troubleshooting. This document is to be used in conjunction with the manufacturer's service manual. It is recommended that all components be replaced equally on both wheel ends of the axle. Failure to do so may affect braking performance. The following recommended practices and guidelines assume that the end users have sufficient skills and knowledge to repair and maintain the related systems at a journeyman level. This must include a fluent understanding of safe shop working practices, not only for the agency but also OSHA/CCOHS/provincial/federal/state and local safety standards. A familiarity with applicable industries, component/system suppliers and vehicle manufacturers is also assumed.

Scope and purpose: This *Recommended Practice* provides guidelines for visual inspection of the typical heavy-duty transit bus air disc brake. The components may be different than pictured, and some procedures will vary. The purpose of this document is to provide a uniform standard for heavy-duty transit bus air disc brake inspection and troubleshooting.

This document represents a common viewpoint of those parties concerned with its provisions, namely operating/planning agencies, manufacturers, consultants, engineers and general interest groups. The application of any standards, recommended practices or guidelines contained herein is voluntary. In some cases, federal and/or state regulations govern portions of a transit system's operations. In those cases, the government regulations take precedence over this standard. The North American Transit Service Association and its parent organization APTA recognize that for certain applications, the standards or practices, as implemented by individual agencies, may be either more or less restrictive than those given in this document.

© 2017 NATSA and its parent organization. No part of this publication may be reproduced in any form, in an electronic retrieval system or otherwise, without the prior written permission of NATSA.

Table of Contents

1. Hazardous material warning.....	1
2. Operation.....	1
2.1 Automatic adjustment	3
3. Initial inspection.....	4
3.1 Auxiliary brake inspection	5
3.2 Overall visual inspection.....	6
3.3 Pads.....	6
3.4 Caliper.....	10
3.5 Bendix/Knorr brake adjuster inspection	11
3.6 Meritor brake adjuster inspection	13
3.7 Brake rotor inspection.....	14
3.8 Brake chamber inspection.....	17
3.9 ABS sensor.....	18
3.10 Validation.....	18
Related APTA standards.....	19
References.....	19
Definitions.....	19
Abbreviations and acronyms.....	19
Summary of document changes	19
Document history.....	19

List of Figures and Tables

Figure 1 Axial and Radial Mounting Designs	2
Figure 2 Cross-Section of Knorr-Bremse Caliper Assembly	2
Figure 3 Meritor EX225 Caliper Gear-Driven Adjustment Mechanism (Not Serviceable)	3
Figure 4 Knorr-Bremse Timing Chain Mechanism (Not Serviceable).....	4
Figure 5 Wear Indicators	7
Figure 6 Meritor (New Style) Pin Wear	7
Figure 7 Knorr SN/SB Rolling Boot Style Wear Indicator	8
Figure 8 Knorr SN/SB Solid Rubber Bushing Style Wear Indicator.....	8
Figure 9 Condition of the Wear Indicator After Use in Revenue Service	9
Figure 10 Brake Pad/Disc Wear Check Using Caliper to Caliper Position Notch	9
Figure 11 Caliper to Carrier Markings	10
Figure 12 Adjuster Protective Cap and Tab.....	11
Figure 13 Brake Adjuster Inspection Locations	12
Figure 14 Knorr Shear Adapter	13
Figure 15 Meritor Brake Adjuster Setting	14
Figure 16 Brake Rotor	14
Figure 17 Brake Rotor with Small Heat Checks.....	15
Figure 18 Brake Rotor with Large Cracks.....	15
Figure 19 Brake Rotor Grooves.....	16
Figure 20 Brake Overheating.....	16
Figure 21 Brake Chambers	17
Figure 22 Brake Chamber Housing Drain Plug.....	17
Figure 23 Brake Chamber Elbow and Drain Vent Plugs.....	18



Participants

The American Public Transportation Association greatly appreciates the contributions of the **APTA Bus Brake Working Group**, which provided the primary effort in the drafting of this document.

At the time this standard was completed, the working group included the following members:

Jerry Guaracino, *Chair*
David Domine, *Vice Chair*

James Baldwin
Mark Barker
Alvin Blakes
John Brundage
John Campo
Bruce Dahl
Tim Derr
Jack Dooley
Heiner Falke
Steve Farrar

Frank Forde
Victor Guillot
Samet Gursel
Shannon Henry
Jim Heuchert
Chip Hurst
Andy Jacobson
David Kwapis
Geoff Lawrence
David Lawrence

Ricky Mares
Brian Markey
Dennis McNichol
Abdulkadir Omar
Chad Robinson
Karl Robinson
Oscar Tostado
Gene Walker
Hans Wimmer
Jeremy Zills

Project team

Saahir Brewington, *APTA*

Introduction

This introduction is not part of APTA BTS-BC-RP-006-17, "Transit Bus Air Disc Brake Operation and Wheels-On Inspection."

This *Recommended Practice* reflects the consensus of the APTA Bus Standards Program members on the items, methods and procedures that have provided the best performance record based on the experiences of those present and participating in meetings of the program task forces and working groups. *Recommended Practices* are voluntary, industry-developed and consensus-based practices that assist equipment suppliers, vehicle and component manufacturers, and maintenance personnel in the construction, assembly, operation and maintenance of transit bus vehicles. *Recommended Practices* may include test methodologies and informational documents. *Recommended Practices* are non-exclusive and voluntary; they are intended to neither endorse nor discourage the use of any product or procedure. All areas and items included therein are subject to OEM's and manufacturers' supplemental or superseding recommendations.

APTA recommends the use of this document by:

- individuals or organizations that operate rail transit systems;
- individuals or organizations that contract with others for the operation of rail transit systems; and
- individuals or organizations that influence how rail transit systems are operated (including but not limited to consultants, designers and contractors).

Transit Bus Air Disc Brake Operation and Wheels-On Inspection

1. Hazardous material warning

Most brake pads no longer contain asbestos fibers. However, if working with any component that does contain asbestos, take all the necessary precautions prescribed by OSHA, and follow all federal, provincial/state and local safety requirements. The health impact of non-asbestos fibers (brake pads with glass, mineral wool, ceramic, aramid, carbon, etc.) is not specifically covered under current OSHA regulations. Although medical experts do not agree about the possible long-term risks of working with and breathing non-asbestos fibers, some experts believe that long-term exposure could cause pneumoconiosis, fibrosis and cancer. Therefore, it is recommended that workers avoid dust when working on brakes that contain non-asbestos materials.

Brake pads may also contain crystalline silica, lead, antimony, phenol and other possibly hazardous materials. Refer to the material's MSDS for all necessary precautions. Follow the general safety procedures listed below when working with braking components:

- Whenever possible, work on brakes in a separate area away from other operations.
- Always wear a respirator approved by NIOSH or MSHA during all brake service procedures.
- *Never* use compressed air or dry brushing to clean brake parts, assemblies or the working area. OSHA recommends using cylinders that enclose the brake. The cylinders have vacuums with HEPA filters and arm sleeves. If such equipment is not available, then carefully clean parts and assemblies in the open air. Used rags should be disposed of with care to avoid getting dust into the air. Use an approved respirator when emptying vacuum cleaners and handling used rags.
- During disassembly, carefully place all parts on the floor or in a suitable cleaning station to avoid getting dust into the air. After vacuum cleaning, any remaining dust should be removed using a rag soaked in water-based cleaner and then wrung until nearly dry.
- Workers should wash their hands before eating, drinking or smoking. Work clothes should not be worn home but should be vacuumed after use and then laundered separately, without shaking, to prevent dust from getting into the air.

2. Operation

The air disc brake consists of an air-operated chamber, two plunger floating calipers, disc brake pads and a vented rotor. There are two air chamber mounting designs (axial and radial; see [Figure 1](#)), which are mounted directly to the caliper assembly. The disc brake can be installed onto any axle and can be used as a vehicle parking brake when equipped with a spring brake chamber.

FIGURE 1

Axial and Radial Mounting Designs

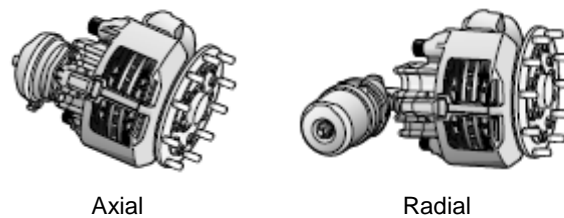

Air disk foundation brakes operate as all foundation brakes. It takes a force, multiplying and applying it to a rotating member (disc or rotor) attached to the wheels such that a friction is created that converts energy of motion into heat and slows the vehicle. In the case of air disc brakes, air pressure is applied to a diaphragm, and the pressure on the diaphragm creates a large linear force, which is applied to a lever (internal to the brake caliper), which further increases the actuating force. See **Figure 2**.

FIGURE 2

Cross-Section of Knorr-Bremse Caliper Assembly

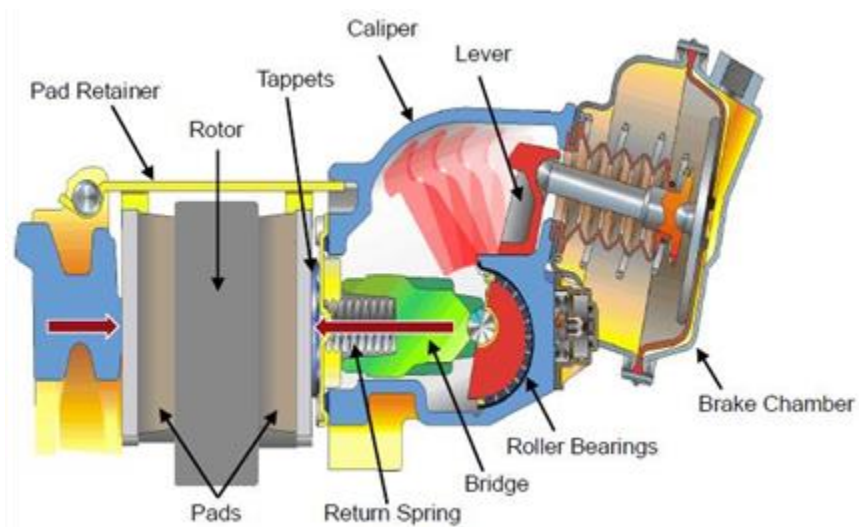

When the brake chamber is pressurized, the chamber push rod moves forward and acts against a cup in the internal lever. The lever, which has an abutment in the caliper housing, then acts against a pair of tappets, which apply the force onto the inner brake pad. The distances from cup to abutment to tappets are designed to provide a high leverage ratio to apply the required actuation force to the inner brake pad. The inner brake pad moves into contact with the brake rotor. The brake caliper, which is free to slide laterally, slides on two guide pins, and the reaction force applies an equal and opposite force to the outer brake pad and against the rotor. The rotor now is clamped between the inner and outer pads, and friction is created as the rotor moves across the clamped pads. This results in the creation of a brake torque acting through the wheel and tire, and this torque creates a stopping force acting on the vehicle through the tire contact patch. The higher the clamping force (which is proportional to the brake chamber air pressure), the higher the resulting brake torque.

The brake is released by reducing the chamber pressure, which in turn reduces the force on the internal lever, and thus the clamping force on the rotor. Integrated return springs return the tappets and operating lever back to the starting position, leaving the pads with a defined running clearance to the rotor.

2.1 Automatic adjustment

To ensure a consistent running clearance between pads and rotor, the brake system is equipped with an automatic adjuster mechanism. The automatic adjuster inside the caliper adjusts the brake pad clearance to compensate for pad and rotor wear. Every time the brake is applied, the system senses whether the running clearance (of the brake pads to the brake rotor) is still within the specified range and does not need to be adjusted, or whether it is beyond the specified range and adjustment is required. For Knorr-Bremse brakes, the total running clearance (sum of clearance on both sides of the disc) should be between 0.024 in (0.60 mm) and 0.043 in. (1.1 mm); smaller clearances may lead to overheating problems. For Meritor EX225 brakes, no minimum is specified, but clearance must not exceed 0.030 in. (0.76 mm).

Disc brakes by design do not allow for measurement of brake chamber pushrod travel, and therefore brake chamber pushrod travel is not referenced in North American Commercial Vehicle Safety Alliance (NACVSA) inspection or out-of-service criteria. Although brake chamber pushrod travel can be calculated by measuring both rotor-to-brake-pad clearances and multiplying this dimension by the lever ratio, it is not necessary.

The adjuster mechanism is not serviceable on either design and should not be disassembled. **Figure 3** and **Figure 4** show the difference between the Meritor EX225 (gear-driven) and the Knorr-Bremse (timing chain) caliper adjusting mechanism.

FIGURE 3

Meritor EX225 Caliper Gear-Driven Adjustment Mechanism (Not Serviceable)

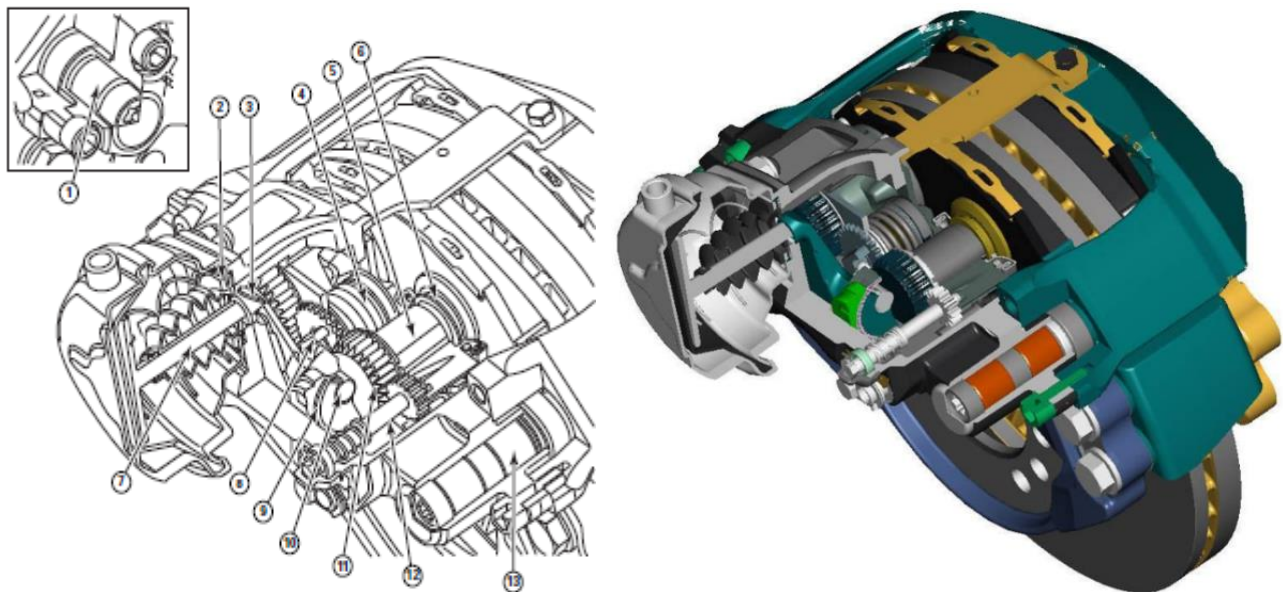

Legend:

- 1 Short slide pin oval bushing
- 2 Housing seal
- 3 Operating shaft
- 4 Return spring
- 5 Piston
- 6 Piston head
- 7 Chamber piston
- 8 Adjuster shaft
- 9 Half bearing
- 10 Roller
- 11 Tappet
- 12 Adjuster stem
- 13 Long side pin bushing

FIGURE 3

Meritor EX225 Caliper Gear-Driven Adjustment Mechanism (Not Serviceable)

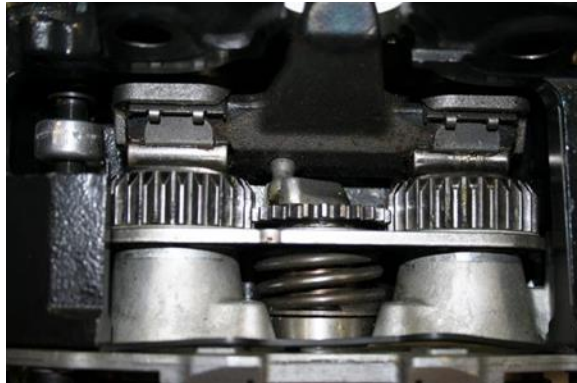

FIGURE 4

Knorr-Bremse Timing Chain Mechanism (Not Serviceable)



3. Initial inspection

The wheels-on inspection, covered in this document, is intended as a cursory examination. Wheels-off inspection is the only comprehensive way of diagnosing brake condition, pad wear and other issues, and should be scheduled per OEM recommendation.

Below is a list of what can be evaluated with a wheels-on inspection:

- functionality check of adjuster
- overheated wheel-end conditions
- brake drag (turning the wheel by hand to determine if it is restricted or free-turning)
- loose or missing hardware
- brake chamber vent hole obstructions (missing or damaged rubber elbows)
- possible problems with inboard pad by checking inside rotor surface condition
- presence and functionality of adjuster cap
- presence of guide pin cap

APTA BTS-BC-RP-006-17
Transit Bus Air Disc Brake Operation and Wheels-On Inspection

It is not possible to determine the following conditions with wheels on:

- condition of guide pin boots
- condition of tappets and boot assemblies
- full caliper movement along guide pins
- clearance measurement of guide pins
- accurate thickness of remaining friction material
- condition of friction material and pads
- caliper running clearance
- rotor run-out, thickness and thickness variation measurements
- overall functionality of the caliper

Components like pads, brake calipers, brake chambers, rotors, wheel bearings, boots, seals, sensor connections, slide pins and bushings are wear items. In addition to replacing them when damaged, each property should establish a schedule to replace these components based on the local operating conditions and usage history. Components should be replaced only when necessary. Advanced engineering, technology and materials provide a long lifetime for these components. It is very important to ensure that all seals are maintained in excellent condition, and they should be replaced with new seals when the caliper is removed or whenever seal damage is identified.

NOTE: Moisture and/or contaminants entering the mechanism will eventually cause the brake caliper to malfunction.

During visual inspection, the caliper and rotor should be inspected for defects, including the following:

- loose and missing fasteners
- rotor damage
- slide pin seal failure
- adjustment mechanism covers and seals
- brake pad overall condition and wear
- brake chamber mounting
- air leaks
- visual pad wear indicator

To determine a proactive inspection and replacement schedule, consult the agency's maintenance policy and component usage history. These may be based on mileage, brake duty/event cycles or time. They may include variables such as climatic considerations, unique operating parameters or a combination of both. The replacement schedules will vary from agency to agency but should not exceed OEM recommendation.

Any historical data must be accurate, updated as required and meet the challenge of consistent performance, reliability and repeatability. Agencies that have the expertise of data collection, evaluation and mechanical knowledge can use this historical data to schedule brake system component replacement/rebuild intervals. If historical data is unavailable, then a program of data collection should be implemented for future needs.

3.1 Auxiliary brake inspection

Service brakes are designed to stop a vehicle in a safe and controlled manner. However, for enhanced drivability and extended brake life, most buses are equipped with supplemental braking systems. Apparent brake problems could be associated with these supplemental brakes. Because of the many different applications (transmission retarder, engine brake, driveline retarder, regenerative braking) and configurations (auto apply, electronic controlled, air controlled), consult the OEM manual for proper testing procedures.

APTA BTS-BC-RP-006-17
Transit Bus Air Disc Brake Operation and Wheels-On Inspection

Supplemental braking (high-efficiency retarders) may lead to surface polishing of the brake pad or rotor. This may lead to squealing and inefficient brakes.

3.2 Overall visual inspection

Check for loose or missing parts (including fasteners), broken or cracked air hoses, air system leaks, and damaged components. Check that brake hoses are properly secured, but allow full caliper movement during normal operation and allow for even pad wear.

Visually inspect for missing or loose caliper mounting bolts or evidence of movement. Re-torquing the bolts is not recommended. If you see evidence of loose bolts (such as witness marks that are not indexed), then continue to the wheels-off inspection.

Inspect the rotor for damage, heat checks, wear and bluing. Inspect the torque plate for cracks and damage. Any of these would require removal of the wheels and further investigation.

3.3 Pads

There are several methods available for estimating pad thickness, such as visual (mechanical) indicators, inspection tools (such as bore scope, mirror or camera), or electronic pad wear indicators (end-of-life or potentiometer sensors). These methods will provide only an estimation of the remaining pad life. For an accurate pad thickness measurement, wheels must be removed and pads measured directly.

Inspection of the visual wear indicator may allow for a quick estimate of usable brake pad material. The Knorr mechanical wear indicator measures the relative movement between the caliper body and the caliper bridge casting (the torque plate that straddles the rotor), which indicates only the outboard pad wear—it cannot measure any wear that has occurred on the inboard pad.

The Meritor mechanical wear indicator pin (**Figure 5**) measures the relative travel between the inboard pad backing plate and the inside face of the caliper casting opening. This measures the extension of the tappet assembly that has compensated for lining wear, which is the combined wear of both inboard and outboard pads. However, it cannot distinguish whether either pad is worn more than the other.

It should also be recognized that as brake rotor material is worn from the swept area, wear indicators will show less usable lining material than is truly remaining.

NOTE: Neither style of visual wear indicator can identify uneven pad wear. In the case where one pad is already below the wear limit and the other pad is not, the visual indicator will be misleading. In the extreme case, where one pad is fully worn and the other shows no wear, the Meritor indicator would show 50 percent remaining, and the Knorr may show 100 percent or 0 percent (depending on which pad is fully worn), and either case may result in metal-to-metal contact.

FIGURE 5
Wear Indicators

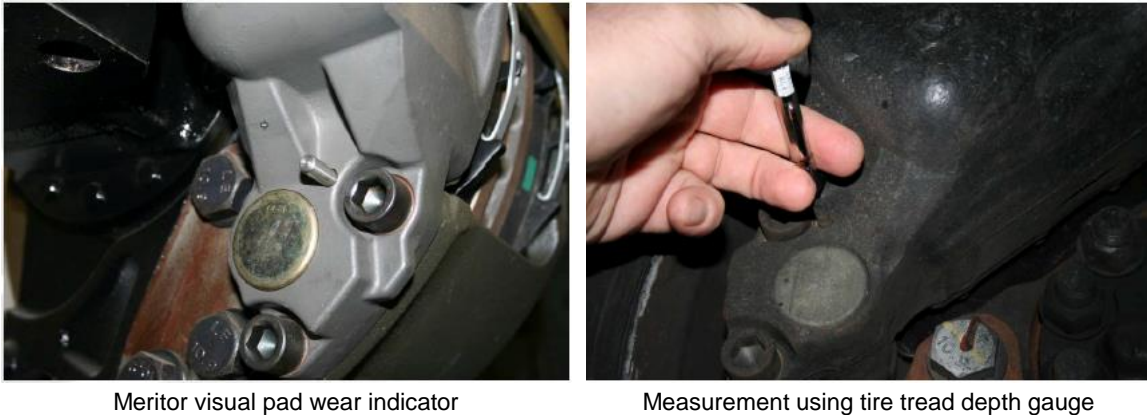

On the Meritor EX225 setup, the pad/rotor wear can be visually estimated without removing the wheel by viewing the protrusion of the wear indicator pin (**Figure 6**). If pin protrusion is less than 0.16 in. (4 mm), then the pads require further inspection or replacement.

FIGURE 6
Meritor (New Style) Pin Wear

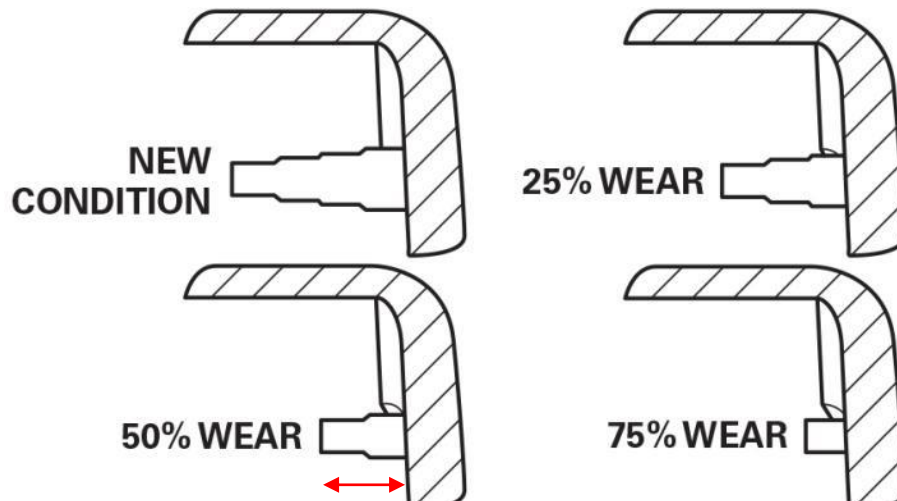

For Knorr SN/SB series calipers, equipped with rubber bush type with axial ribbing, the outboard pad/rotor wear can be estimated without removing the wheel by noting the position of the wear marker point (the transition point from ribbed to smooth surface); see **Figure 7**. If smooth surface is not visible, then perform a wheel-off inspection as recommended by the *Recommended Practice* **APTA RP-xxx-00x-15**, “Transit Bus Air Disc Brake Wheels-Off Inspection and Reline.”

FIGURE 7
Knorr SN/SB Rolling Boot Style Wear Indicator

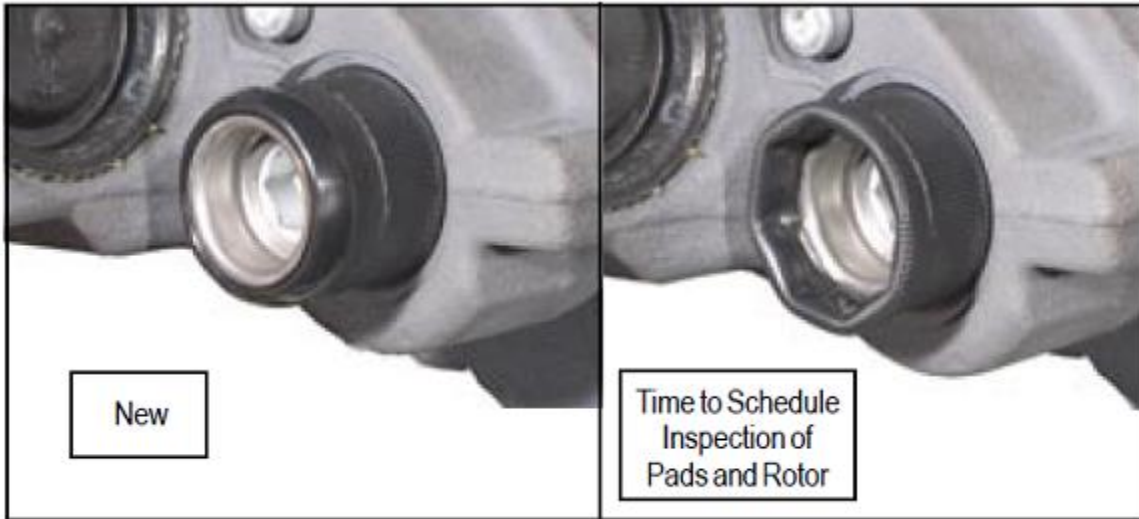

For Knorr SN/SB series calipers equipped with solid rubber bushing indicator, checking the position of the caliper compared with the flex-guide pin will help determine pad/disc wear without removing the wheel (see **Figure 8**). If the pad wear indicator protrudes less than 0.040 in. (1.02 mm), then the wheels must be removed to measure pads and rotors on that axle (both sides).

FIGURE 8
Knorr SN/SB Solid Rubber Bushing Style Wear Indicator

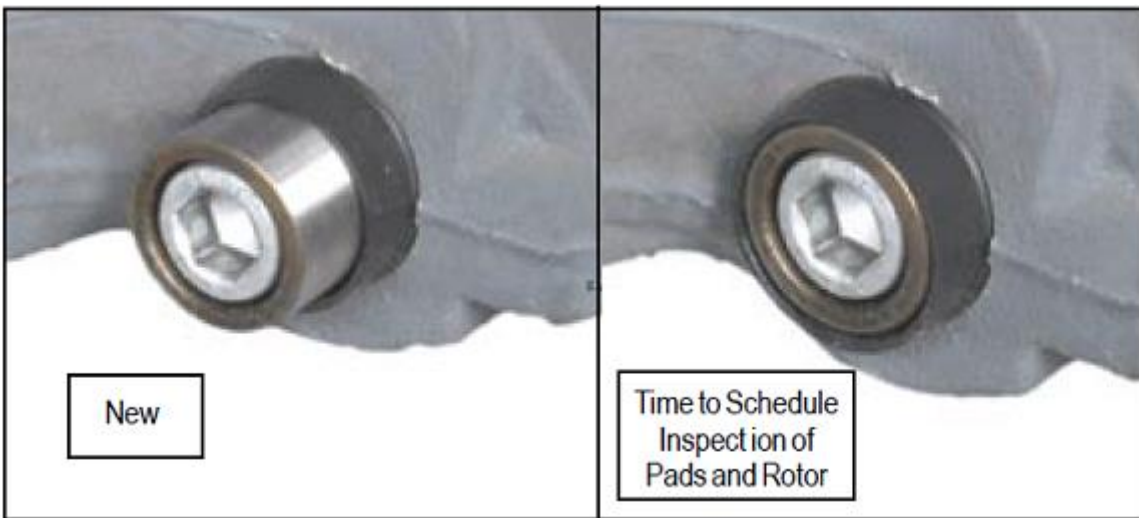

Dirt, road salts and debris can obstruct the view of the guide pin or wear indicator (**Figure 9**). Care should be exercised to ensure that the solid rubber bushing is not mistaken for the stainless steel guide pin.

APTA BTS-BC-RP-006-17
Transit Bus Air Disc Brake Operation and Wheels-On Inspection

FIGURE 9

Condition of the Wear Indicator After Use in Revenue Service



On air disc brakes that are equipped with a caliper to carrier marking (**Figure 10** and **Figure 11**), the pad/disc wear can be visually determined by viewing the position of the caliper and carrier markings (“P” compared with the carrier marking “R”). If caliper and carrier markings are within 1 mm of alignment, then the wheels must be removed to measure pads and rotors on that axle (both sides).

FIGURE 10

Brake Pad/Disc Wear Check Using Caliper to Caliper Position Notch

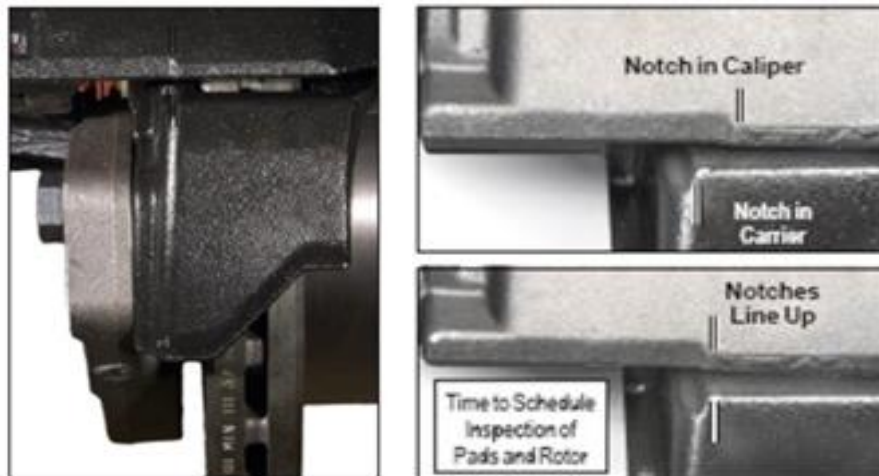
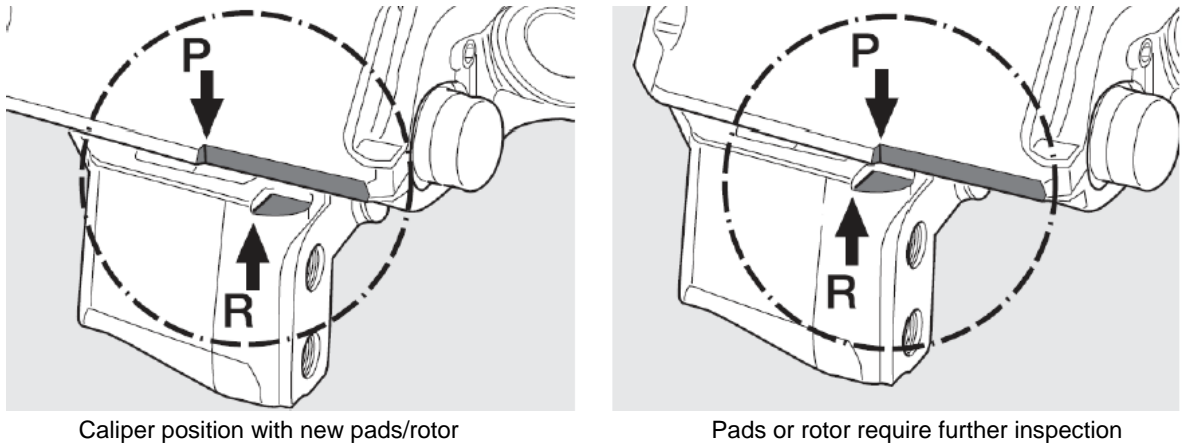

FIGURE 11
Caliper to Carrier Markings



CAUTION: In extreme uneven wear conditions, individual pads may wear to their minimum before the visual indicator provides a warning. Visual pad inspection should always accompany running clearance check.

3.4 Caliper

Unlike drum brakes, current air disc brake designs do not allow the brake stroke to be checked or measured. However, there are a number of tests/inspections that can be performed to ensure that the calipers are working properly:

- It is very important to ensure that all seals are maintained in excellent condition. Moisture and contaminants will cause the brake caliper to fail and malfunction. Check that all sealing caps and plugs are in place, providing a watertight seal. Note that not all seals/boots are visible with the wheels on.
- Check caliper adjustment and movement:
 - Make sure the caliper allows for movement by grabbing the caliper/brake chamber assembly and checking for a small amount of relative movement.
 - With the parking chamber temporarily released and the wheels chocked, check for the slight movement of the brake caliper. This very slight movement, less than 0.080 in. (2.03 mm) (approximately the thickness of a nickel) in the axial (inboard/outboard) direction, indicates that the brake is moving properly on its slide pins. If the caliper has no movement or appears to move greater than 0.080 in. (2.03 mm), then other problems may exist. Remove the wheels for further inspection and/or service.
- Check for oil or grease contamination of the brake assembly.
- Check presence and condition of the sealing caps, guide pins and adjuster stamps.
- Inspect caliper mounting bolts for presence and signs of rust, movement or looseness.
- Inspect caliper for heavy rust and damage, which may indicate a non-working or overheated brake.
- Inspect condition of adjuster protective cap (**Figure 12**).

FIGURE 12
Adjuster Protective Cap and Tab

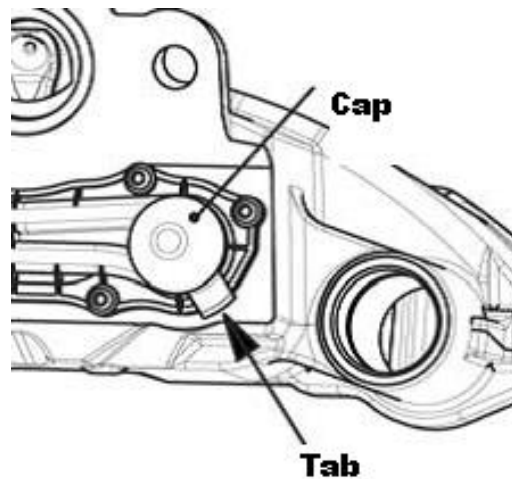

Rust, moisture and contamination of the internal caliper mechanism can cause the caliper to malfunction and not adjust or release, resulting in dragging brakes.

The automatic brake adjuster is part of the caliper assembly. It needs to be routinely inspected to ensure that it is functioning properly. Inspection of the tappet boots is also important but cannot be accomplished with wheels on. It is recommended to remove the wheels and inspect the tappet boots periodically.

3.5 Bendix/Knorr brake adjuster inspection

The brake adjuster is located on the inboard side of the caliper. It will be above the wear indicator, behind the brake chamber (see [Figure 13](#)).

To inspect the adjuster operation, remove the adjuster cap using the tab and install the shear adapter. Do not attempt to turn the splines without the adapter. Use a 10 mm box end wrench or ratchet/socket to turn the shear adapter counterclockwise (one half-turn). Make a few moderate brake applications (at about 30 psi). Wrench/socket should turn clockwise in small increments. Listen for the clicks as the mechanism increases running clearance.

FIGURE 13
Brake Adjuster Inspection Locations

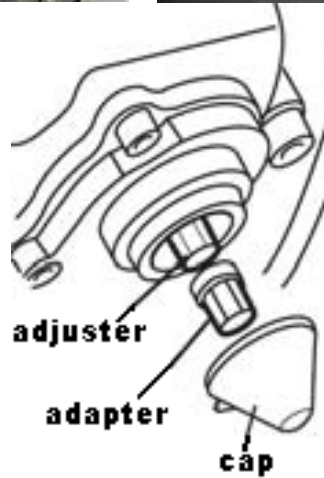

Seized pads or caliper guide pins can lead to a failed shear adapter (**Figure 14**). If the shear adapter fails:

- Replace the shear adapter.
- Remove wheels and pads.
- Move caliper several times over the whole length of the guide pins.
- Try to turn the shear adapter again.

FIGURE 14
Knorr Shear Adapter

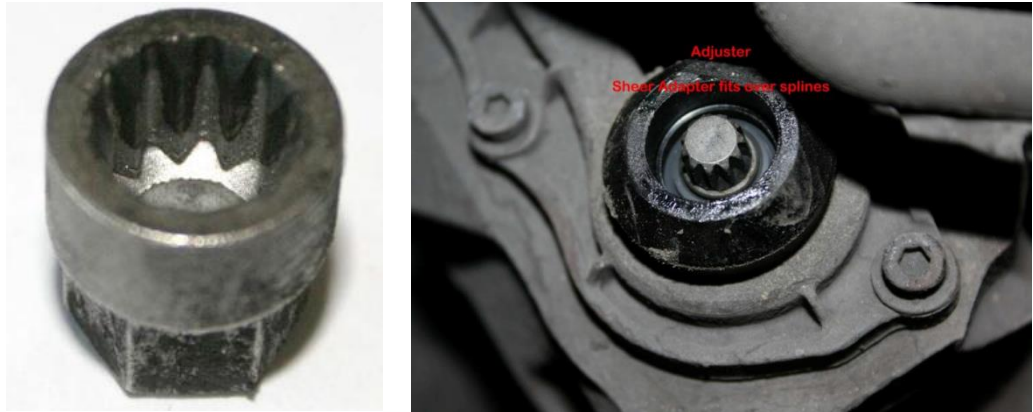

A Knorr shear adapter fits over splines and is designed to fail if excessive torque is required.

If the shear adapter fails for a second time, then the adjuster mechanism is seized and the caliper *must be replaced*.

CAUTION: *Do not* turn the adjuster without a shear adapter, or the adjuster will be damaged.

CAUTION: *Do not* use an open-end wrench on the shear adapter, or it will be damaged.

Replace the calipers if there is no movement of the adjuster stem, movement on the first brake application only, or if it moves counterclockwise, then clockwise, on each brake application.

Make sure there is some grease applied inside the cap while reinstalling.

3.6 Meritor brake adjuster inspection

Using a 10 mm wrench, rotate the adjuster stem counterclockwise until you feel the adjuster stem stop (**Figure 15**). De-adjustment requires more force than adjustment. Do not exceed 30 ft-lbs (41 Nm) in either direction.

FIGURE 15
Meritor Brake Adjuster Setting



If the manual adjuster does not rotate in either direction, then replace the caliper assembly.

Make sure the wrench is positioned so that it can move clockwise without obstruction. Apply brakes with about 30 psi air pressure five to 10 times. The wrench should turn a small amount clockwise with each brake application, with the amount of movement diminishing with subsequent brake applications. If the wrench does not turn, turns only on first application, or turns forward and backward with every application, then the adjuster has failed and the caliper must be replaced.

3.7 Brake rotor inspection

When the wheels are still on the vehicle, the whole surface of the brake rotors is not visible (**Figure 16**).

FIGURE 16
Brake Rotor

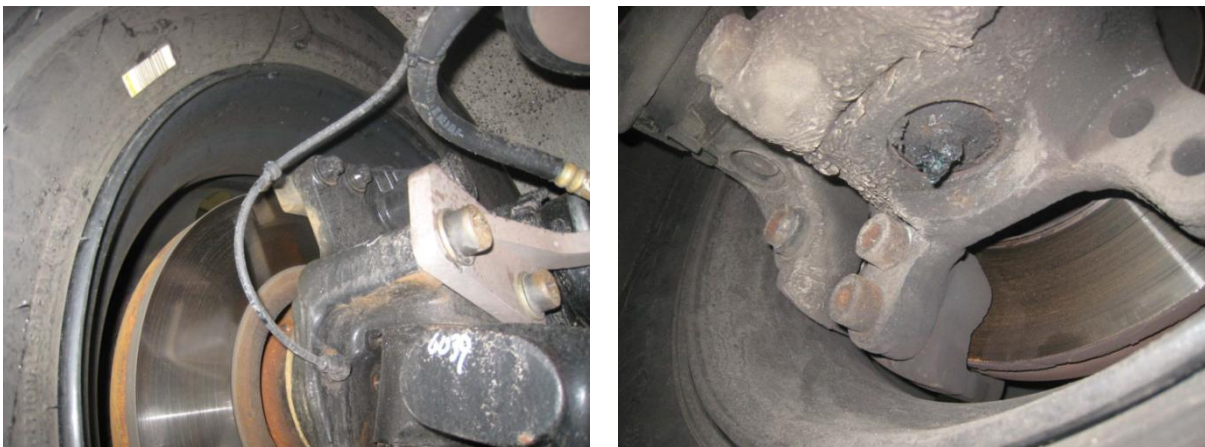

APTA BTS-BC-RP-006-17
Transit Bus Air Disc Brake Operation and Wheels-On Inspection

To determine the general condition of the rotors, complete a visual inspection:

- Inspect the swept area of the rotor for defects and damage. Only the inner side of the rotor can be visually inspected fully with wheels on (although some areas of the outer side of the rotor may be visible through the wheel hand-holes), so extra care should be exercised to check as much of the rotor as possible.
- Brake rotors should be checked for contamination from the following:
 - lubricant residue due to leaking axle seals
 - road debris and contaminants
 - surface rust indicating inoperative brake
- Check surface of rotors for large cracks, grooves, scoring or hot spots. See **Figure 17**, **Figure 18**, **Figure 19** and **Figure 20**.

FIGURE 17

Brake Rotor with Small Heat Checks

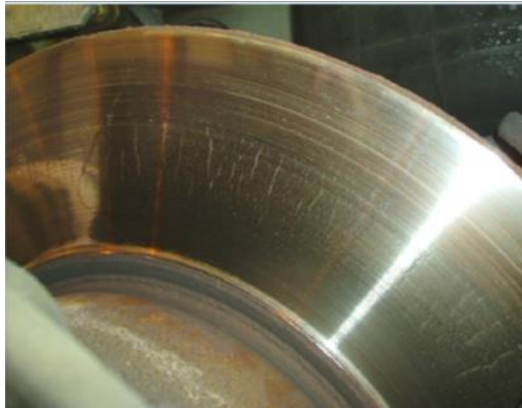

Small heat checks are allowable (as shown).

FIGURE 18

Brake Rotor with Large Cracks

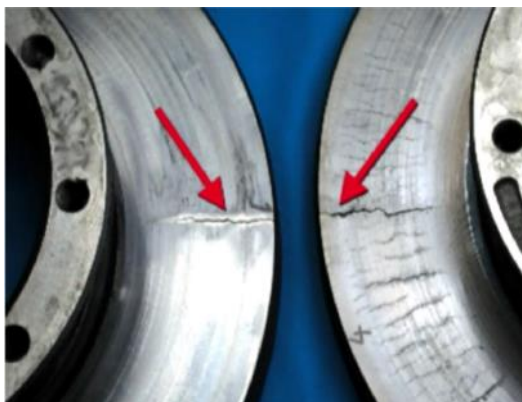

Large cracks creating a split in the rotor are not acceptable and require rotor replacement.

FIGURE 19
Brake Rotor Grooves



Brake rotor with grooves

FIGURE 20
Brake Overheating



Bright-red coloration indicating brake overheating condition

Blue bands or marks on the rotor surface indicate that the rotor was very hot. Also, bright-red coloration of rotor edges and nearby caliper castings indicate that overheating conditions have occurred (see **Figure 20**). Determine the root cause of the overheating condition. Identify and repair the cause of the overheating condition, and then replace the rotors and pads.

APTA BTS-BC-RP-006-17
Transit Bus Air Disc Brake Operation and Wheels-On Inspection

NOTE: Oil- and grease-contaminated rotors should be replaced, as the oil and grease can never be fully removed from the metal and will cause unbalanced brakes.

3.8 Brake chamber inspection

With the brake system at governor full cut-out pressure, release the parking brake (when applicable) and then apply the service brakes and listen for any air leaks. Any leaks mean the vehicle should be taken out of service until repairs are made. Chambers (**Figure 21**) must:

- be the same size on the same axle;
- contain cage tool and sealing plug (if applicable; some chambers have integrated caging bolts);
- display no evidence of contact with wheel, body, suspension or frame;
- have chamber mounting hardware and clamp band hardware (if present) in place and tight; and
- be free of dents and corrosion.

FIGURE 21
Brake Chambers



Front service brake chamber



Rear spring brake chamber

NOTE: Ensure that the bottommost housing plug is removed. Failure to remove a plug from the non-pressure housing may trap contaminants and will cause a slow release or dragging brake.

FIGURE 22
Brake Chamber Housing Drain Plug

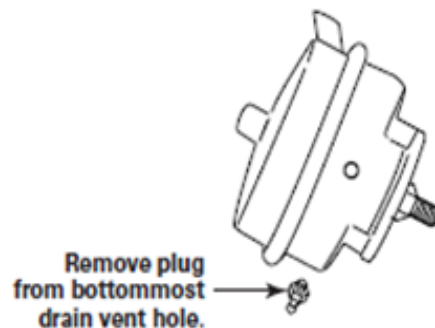
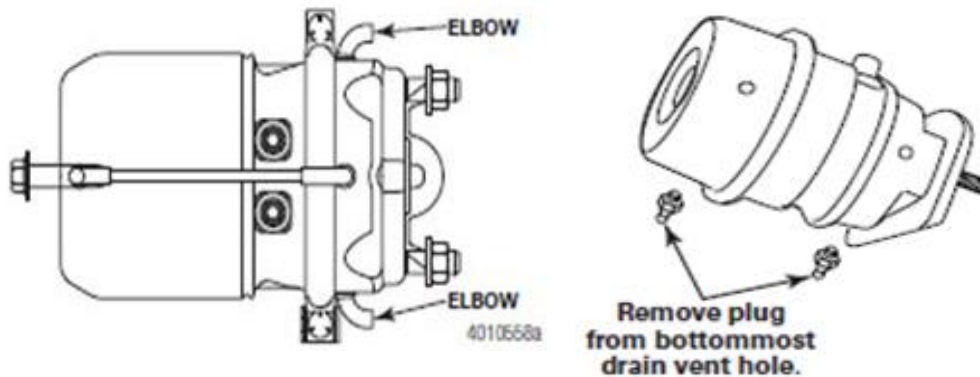

FIGURE 23

Brake Chamber Elbow and Drain Vent Plugs



Further visual inspection should include the following:

- Check the integrity of air hoses:
 - Inspect for cracks, kinks, routing, leaking, chafing, deterioration, proper size and material.
 - Air chambers are equipped with breather holes, and it is important that they be unobstructed and oriented downward to allow water and contaminants to drain from the chamber.

In addition to the recommended practices contained in this document, an onboard electronic brake monitoring (EBM) system is known to be an effective maintenance tool to aid in the inspection and/or troubleshooting of the air disc brake system being serviced. Wheels-on inspection of air disc brake components is difficult, as many critical components are hidden from view. An EBM system monitors the internal actuator and caliper functions and can detect brake actuator overstroke and non-functioning conditions, as well as brake drag and low pad-to-rotor clearance conditions at each vehicle wheel end. This information is subsequently stored in an electronic control unit (ECU) for later retrieval by safety or maintenance personnel via the appropriate diagnostic equipment and is also transmitted in real time over the vehicle J-1939 network. The EBM system can provide critical air brake system diagnostic warnings (air system control, valves, brake actuators and calipers) that may otherwise go undetected.

3.9 ABS sensor

For the ABS to function properly, sensors must be in good condition and correctly adjusted. Inspect the sensors, mounting, adjustment and wiring for damage. Replace as necessary.

3.10 Validation

To complete the inspection, perform a brake performance test to verify satisfactory brake operation. Document the inspection results and return the bus to service if no repairs are needed. Schedule repairs if required.

Based on what is found during the inspection procedure outlined in this document, a more thorough investigation may be called for. The best way to evaluate the condition of an air disc brake setup is by removing the wheels and inspecting all the components. This document can be used in between wheels-off brake checks to inspect the general condition of the system.

APTA BTS-BC-RP-006-17
Transit Bus Air Disc Brake Operation and Wheels-On Inspection

Related APTA standards

APTA BTS-BC-RP-007, Transit Bus Air Disc Brake Wheel-Off Inspection and Reline

References

This *Recommended Practice* is to be used in conjunction with the original equipment manufacturer (OEM) and disc brake manufacturer service manuals.

Definitions

air disc brake assembly: Consists of the brake pads, rotor and caliper assembly.

Abbreviations and acronyms

CCOHS	Canadian Centre for Occupational Health and Safety
EBM	electronic brake monitoring
ECU	electronic control unit
ft-lbs	foot-pounds
HEPA	high-efficiency particulate air
MSDS	material safety data sheet
MSHA	Mine Safety and Health Administration
NACVSA	North American Commercial Vehicle Safety Alliance
NATSA	North American Transportation Services Association
NIOSH	National Institute for Occupational Safety and Health
Nm	Newton-meters
OEM	original equipment manufacturer
OSHA	Occupational Safety and Health Administration
PBBT	performance-based brake test

Summary of document changes

This is a new document hence no changes at this time.

Document history

Document Version	Working Group Vote	Public Comment/ Technical Oversight	CEO Approval	Policy & Planning Approval	Publish Date
First published	Sept. 24, 2015	Oct. 5, 2015	Nov. 13, 2015	Jan. 23, 2017	Jan. 26, 2017
First revision	—	—	—	—	—
Second revision	—	—	—	—	—