

TRANSMISSION 101

Alison Silverstein (alisonsilverstein@mac.com)
NCEP Transmission Technologies Workshop
April 20-21, 2011

OVERVIEW

1. What is transmission and how do we use it?
2. Statistics, maps and costs
3. Roles and benefits of transmission (with examples)
4. Basic transmission levels and equipment
5. Planning the system
6. Closing thoughts
7. Additional details

1) TRANSMISSION AND THE POWER SYSTEM

- **Generation:** creates electric energy using a variety of fuel sources, at many locations.
- **Load:** the homes, factories, offices, and devices that consumer electricity. “Load center” is the location (like a city or major industrial customer) where lots of energy use is concentrated
- **Transmission:** moves electric power long distances from generation points to customer load centers. Usually $>69\text{kV}$
- **Distribution:** distributes electric power and energy the final distance from transmission to loads. Usually operates at 35kV or less.

THE TRANSMISSION SYSTEM

- The electric system was originally built as many local or regional grids, linking generators to loads.
- Local grids were joined to improve reliability and lower costs by sharing generation.
- With the development of power trading markets and long-distance backbone transmission lines, the US and Canada evolved into 3 large regional interconnections.
- 164,000 mi network linking over 75,000 MW of generation to millions of customers served by 3,000 utilities.

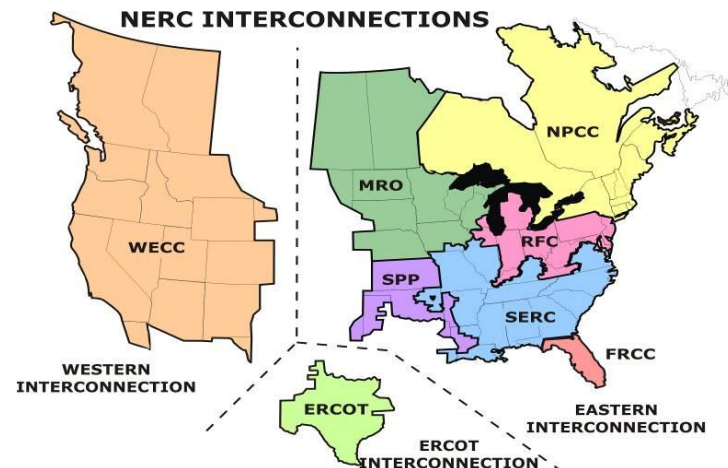
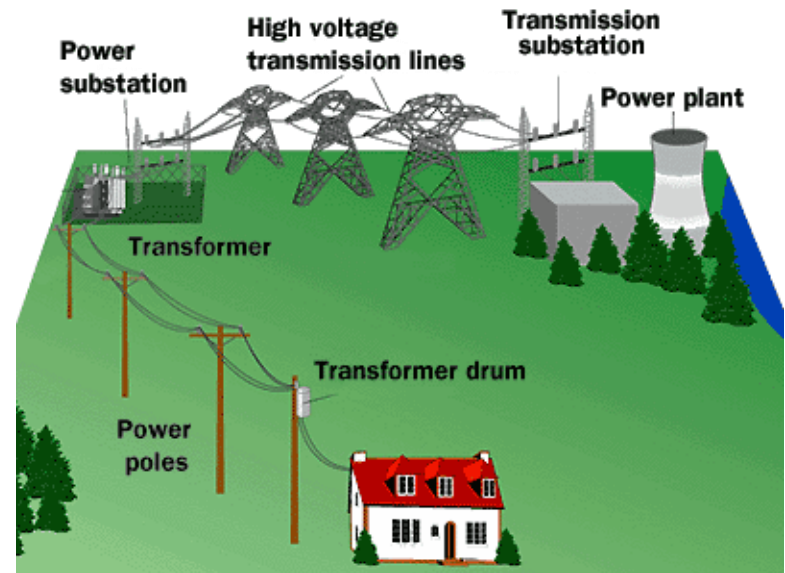

2) STATISTICS, MAPS & COSTS

ALL TRANSMISSION, 69kV AND ABOVE

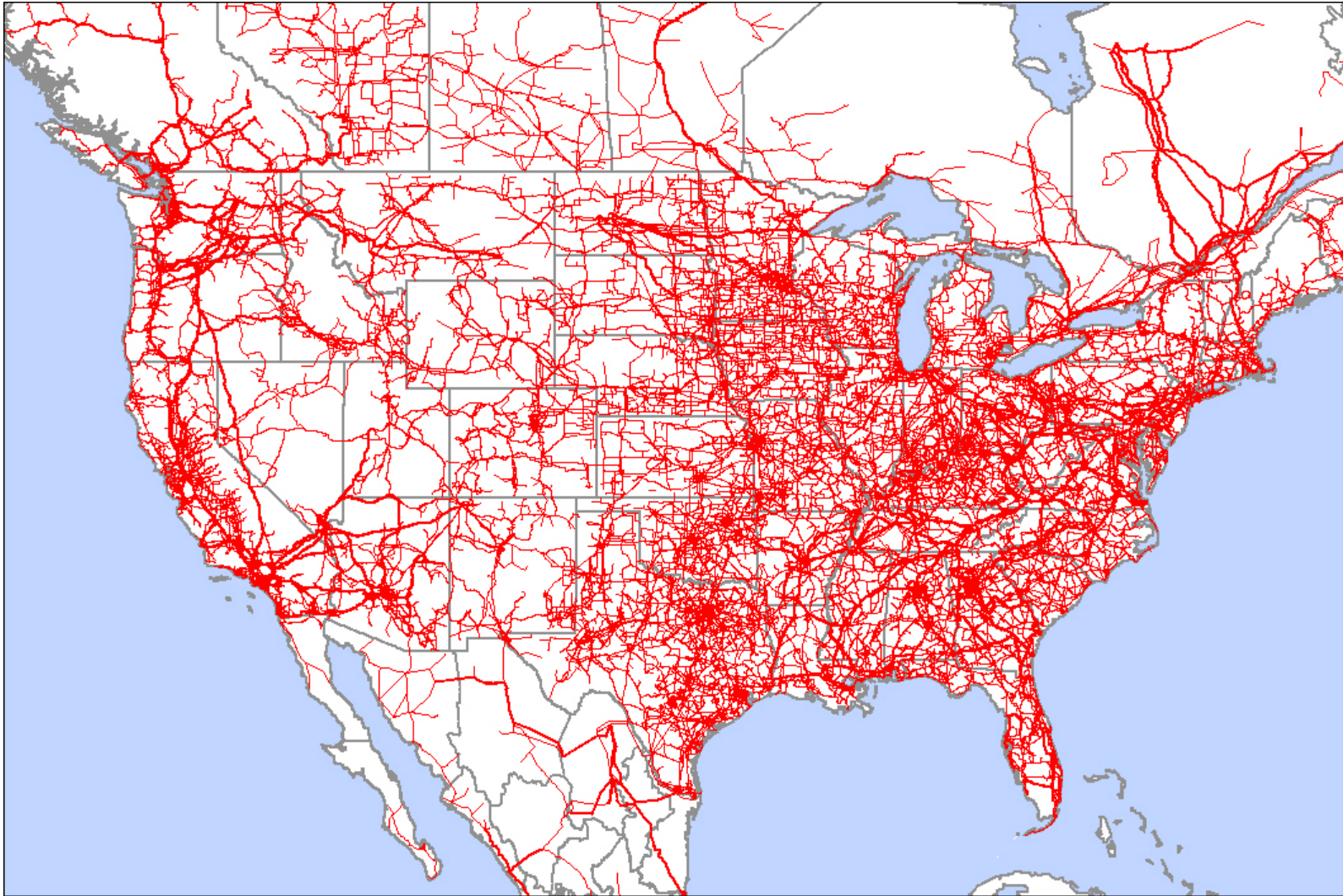

U.S. TRANSMISSION, 230 kV AND ABOVE

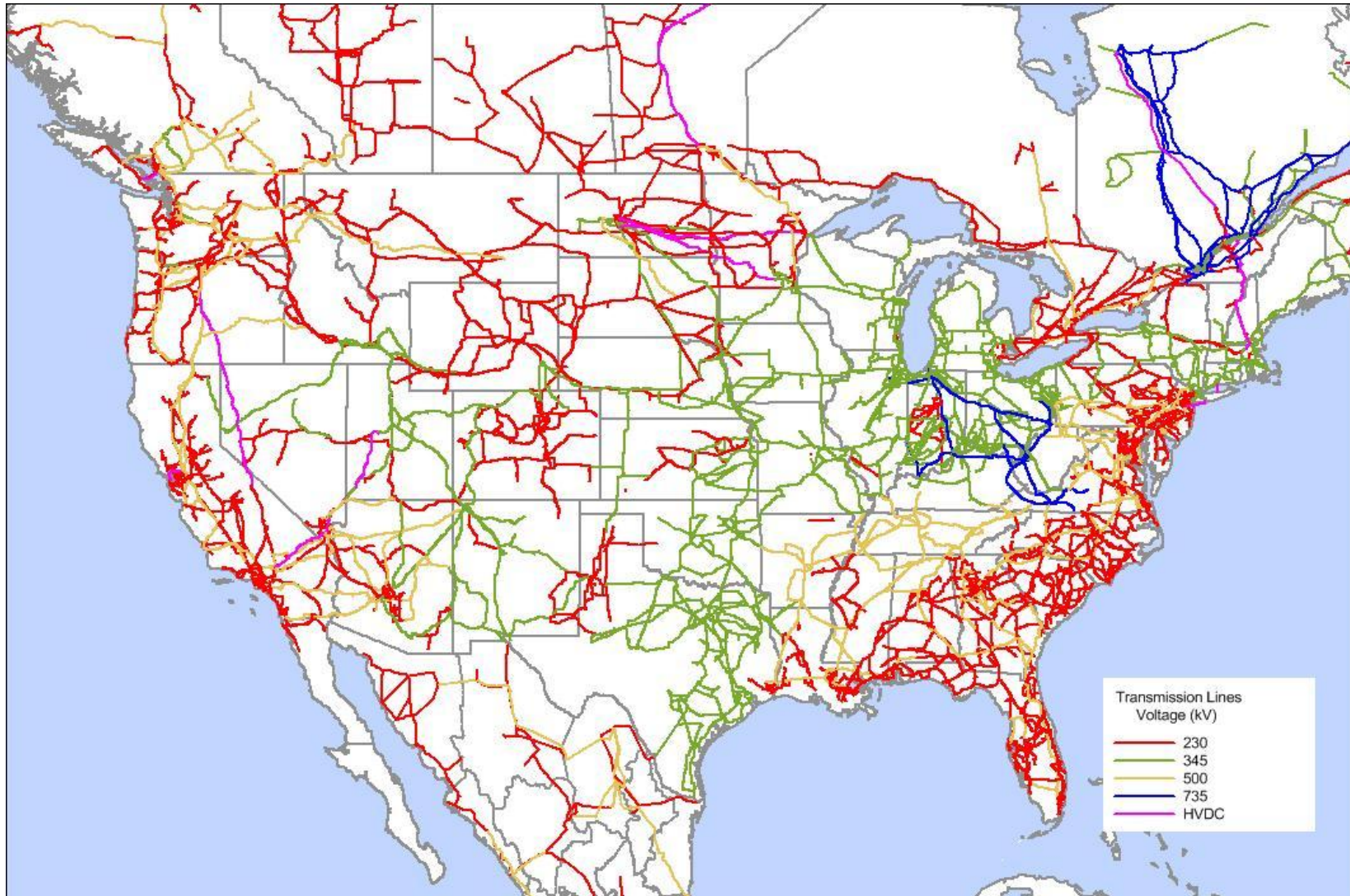

PROPOSED NEW TRANSMISSION, >230kV

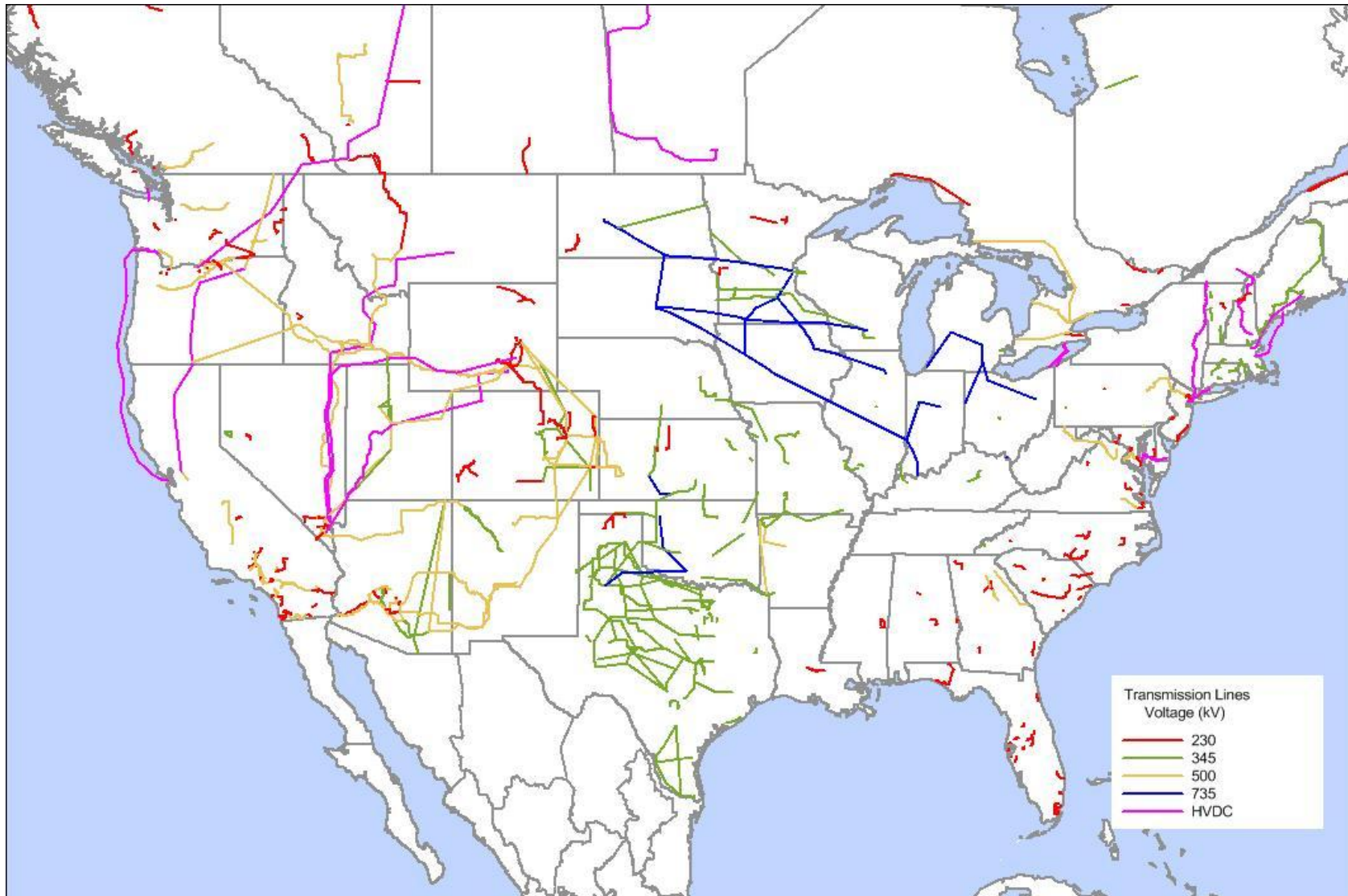

BASIC TRANSMISSION STATISTICS

- 452,699 circuit-miles of transmission in North America in 2009 (per NERC – US, Canada, Mexico, 2010)
 - 280,341 mi in Eastern Intercon
 - 120,763 mi in Western Intercon
 - 28,665 mi in ERCOT
 - Circuit-mile = miles of line x circuits/line
- U.S. transmission (>100kV) projected to grow from 372,340 mi in 2009 to 406,730 mi by 2019
- 15,700 transmission substations in U.S.

U.S. ELECTRIC TRANSMISSION INVESTMENT ACTUAL

Transmission Investment (\$ millions)

(\$Millions (Real \$2008))

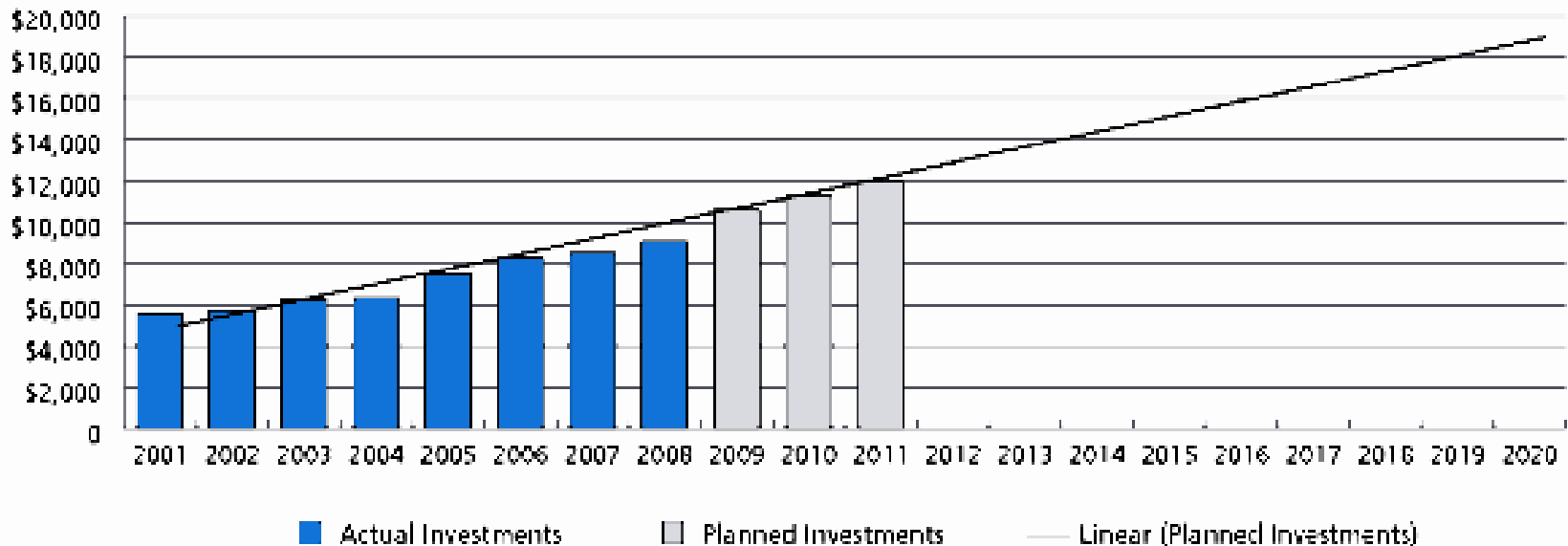

Data represents both vertically integrated and stand-alone transmission companies. Planned total industry expenditures are preliminary and estimated from responses to EEI's Electric Transmission Capital Budget & Forecast Survey. Actual expenditures are from EEI's Annual Property & Plant Capital Investment Survey & Form 1s. Estimated expenditures beyond 2011 are based on a linear approximation of planned industry expenditures for 2009 through 2011.

TRANSMISSION ADDITIONS

- After two flat decades of low transmission construction, NERC finds transmission additions are increasing (in circuit-miles)
- But transmission additions aren't yet keeping up with demand. 2008 Brattle Group estimate that \$298 billion transmission investment needed between 2010 and 2030 to maintain reliable service; EEI says \$56 billion planned 2009-2020.

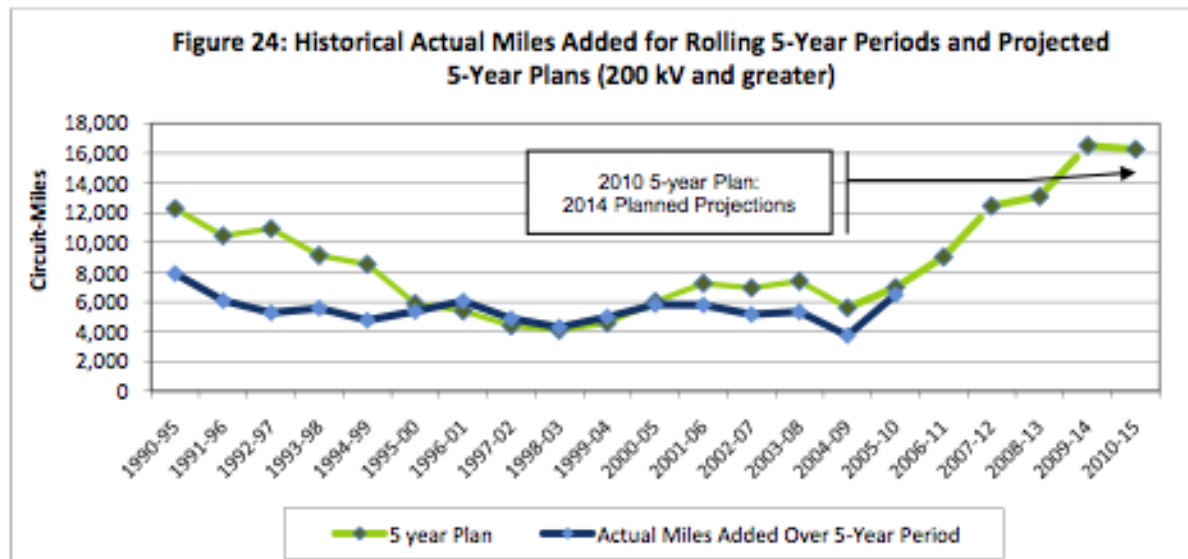

US TRANSMISSION ADDITIONS PLANNED

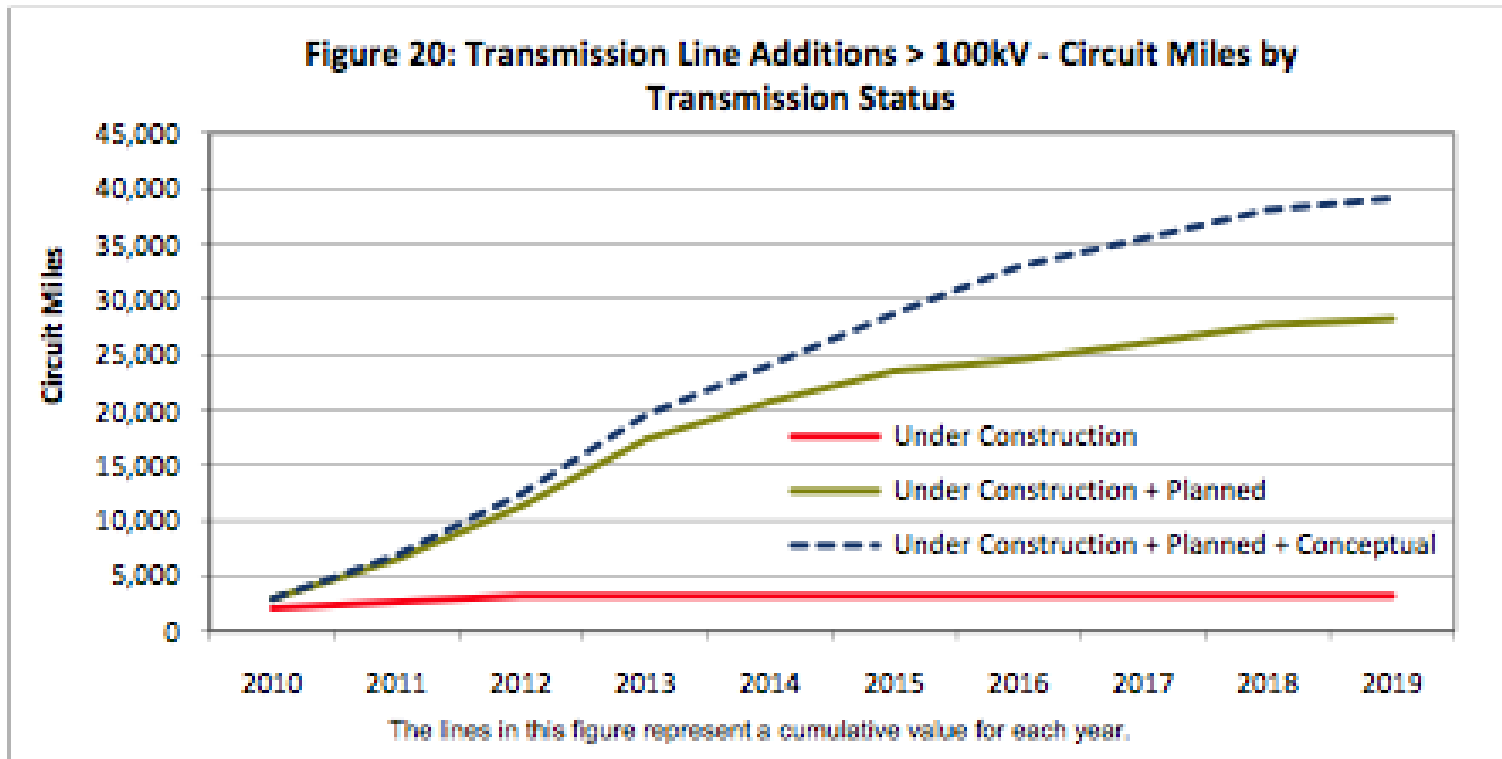

- About 3,100 circuit-miles now under construction as of mid-2010
- About 24,000 circuit-miles in planning phase
- About 12,000 circuit-miles in conceptual stage

Data from NERC 2010 LTRA

NON-LINE TRANSMISSION INVESTMENTS

- Substations, equipment replacements (transformers, phase shifters), reactive compensation (capacitors, static VAR compensators, dynamic reactive sources such as FACTS devices)
- Control systems (EMS, SCADA, dynamic line rating)
- Smart grid -- monitoring devices (phasor measurement units), transmission automation (automatic reclosers), analytics and diagnostic tools
- Communication networks
- Physical and cyber-security

TRANSMISSION INVESTMENT AND RATES

- Hard to get estimates of total transmission investment:
 - \$91 billion spent by IOUs 1980-2008 (EIA),
 - expect another \$56 billion investment by IOUs from 2009-2020 (EEI).
- Transmission investment has been growing slowly – 9,700 mi of HVT were built in the 1990s, around 9,000 mi built in 2001-2010, and 39,000 circuit-miles could be built in this decade (per NERC).
- On average, total transmission capital and operating costs translated into rates equal less than 5% of a ratepayer's monthly electric bill – so substantial increases in transmission investment can end up causing very small rate increases, or be wholly offset by energy savings from accessing low-cost generation or reducing line losses and congestion costs.

TRANSMISSION OWNERSHIP AND FUNDING

- Electric utility – recovers costs through cost-of-service rates to ratepayers and transmission customers
 - Investor-owned, vertically integrated or functionally separate wires company subsidiary
 - Municipal utility
 - Cooperative (or Generation & Transmission coop for other coops)
 - Independent transmission company (ITC, American Transmission Co.)
- Merchant transmission (third-party non-utility ownership, often DC projects like Neptune) – recover costs through market-based contracts and fees
- REITs – IRS has approved T&D assets as real estate for REIT requirements (Hunt Transmission)
- Project financing – create a project-specific LLC to borrow against project cash flows and improve leverage and tax status

3) ROLES AND BENEFITS OF TRANSMISSION

1. Interconnect new generation and resource areas to the grid
2. Improve reliability by strengthening the grid
3. Improve reliability and manage risk by providing access to additional generation resources
4. Reduce energy cost by providing access to diverse generation resources
5. Reduce congestion by creating new flow paths and system capacity
6. Increase efficiency by reducing line losses
7. Make wholesale markets more competitive and efficient

REASONS FOR NEW TRANSMISSION

- Over half of these projects planned by 2019 are to maintain or improve reliability
- A quarter are for integrating renewables (EEI says >12,900 mi of transmission, \$37 billion)
- BUT – the average project is less than 70 miles long, so most are local rather than regional/interstate.

Figure 23: Relative Transmission Mile Additions >100 kV by Primary Driver

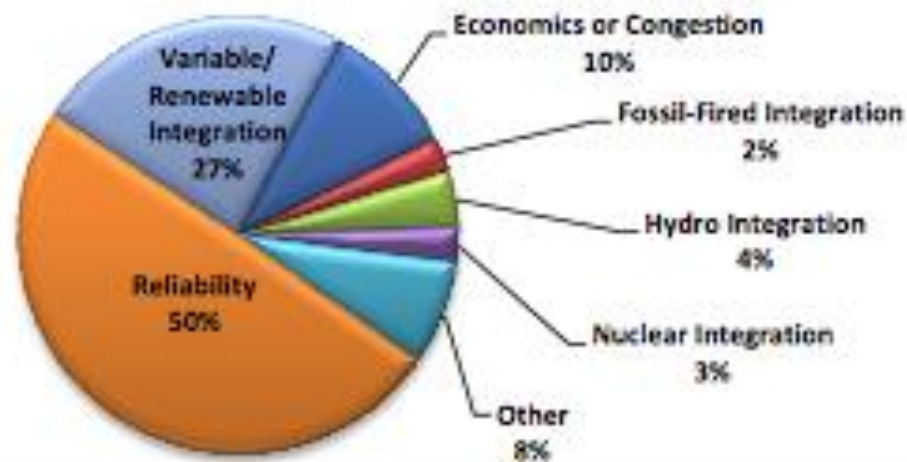

INTERCONNECT NEW GENERATION COMANCHE-DANIELS PEAK LINE

- Interconnects Comanche Power Plant Unit 3 (\$1.4 billion, 750 MW coal-fired plant) to PSCo (XCel) grid
- Double-circuit 345 kV line
- Cost of \$150 million



INTERCONNECT NEW GENERATION RESOURCES POLICY PUSH FOR RENEWABLE GENERATION

RPS Policies

www.dsireusa.org / April 2011

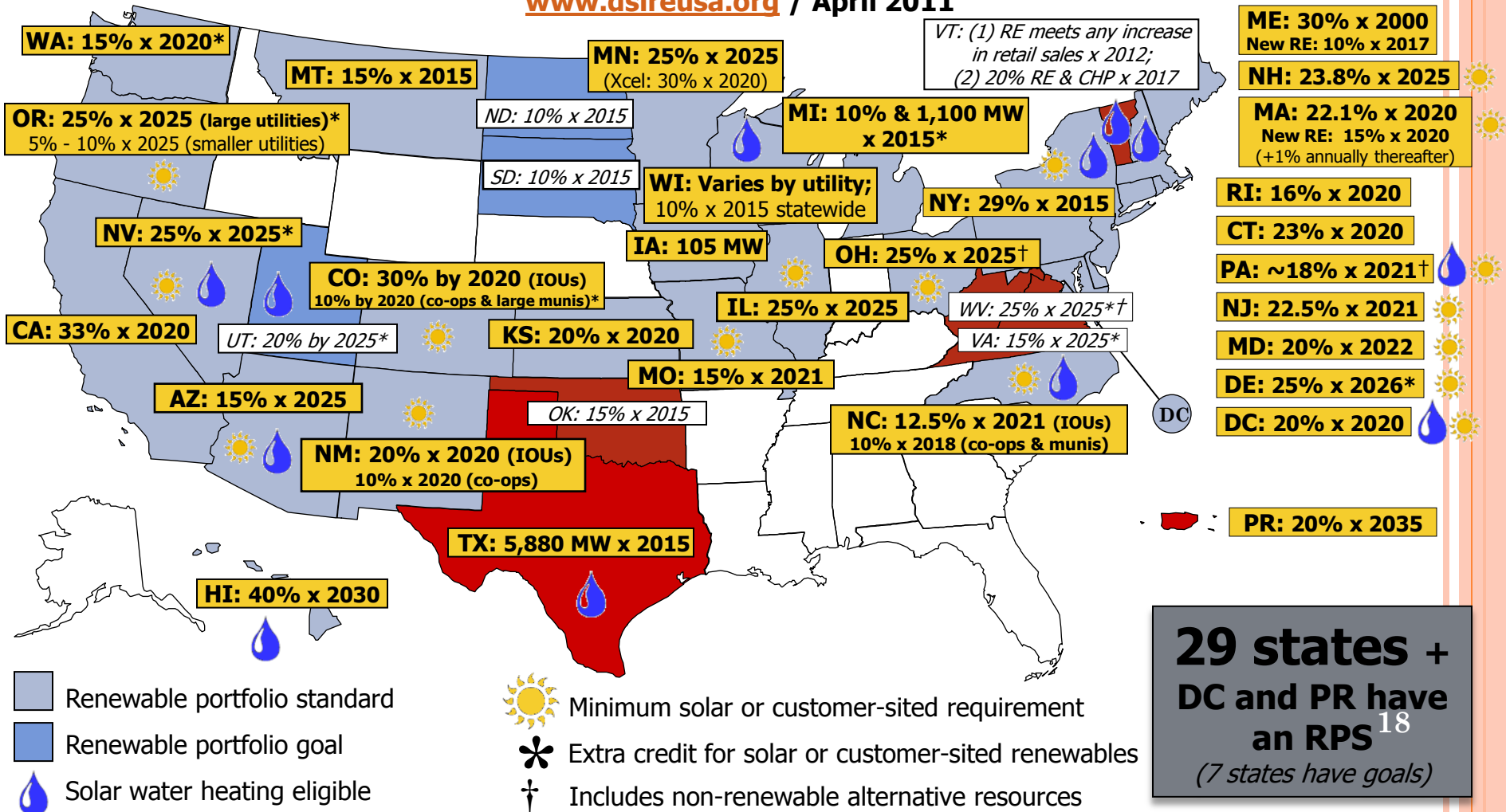

LOTS OF POTENTIAL NEW GENERATION AWAITING INTERCONNECTION

Wind Resource Potential

47% of Nation's Generation
Interconnection Queue

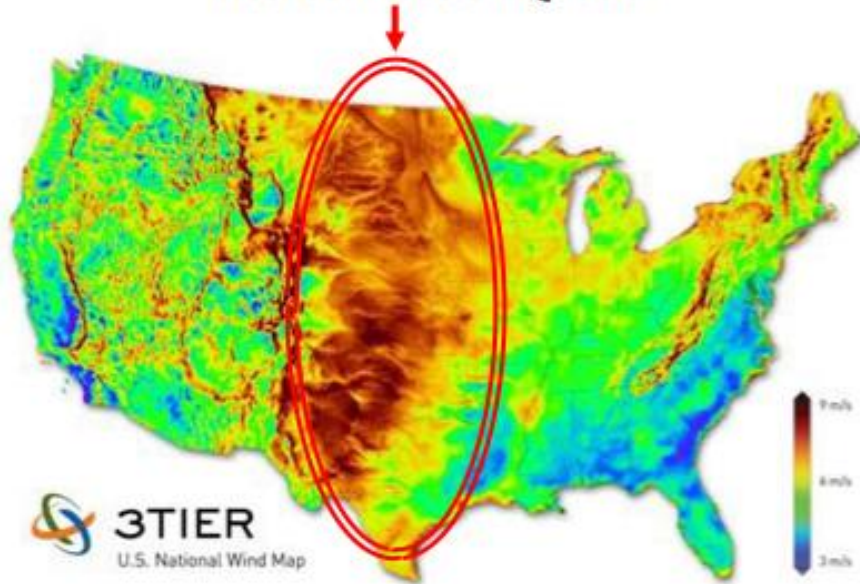

Transmission System

47% of Nation's Generation
Interconnection Queue



Existing Transmission 500 kV and above shown.

INTERCONNECT NEW GENERATION AREAS

TEXAS CREZ LINES

- Over 2,300 miles of 345 kV transmission will be built at a cost of \$8 billion by seven transmission utilities chosen by the PUCTx.
- These lines will deliver 18.5 GW of windpower from W. TX and the Panhandle to central TX.
- Benefits will include \$30 bil in economic gains, including lower energy costs, landowner income, tax income, economic development and jobs, plus lower air emissions, 17 bil gal water saved.
- Average ratepayer cost = \$4/month

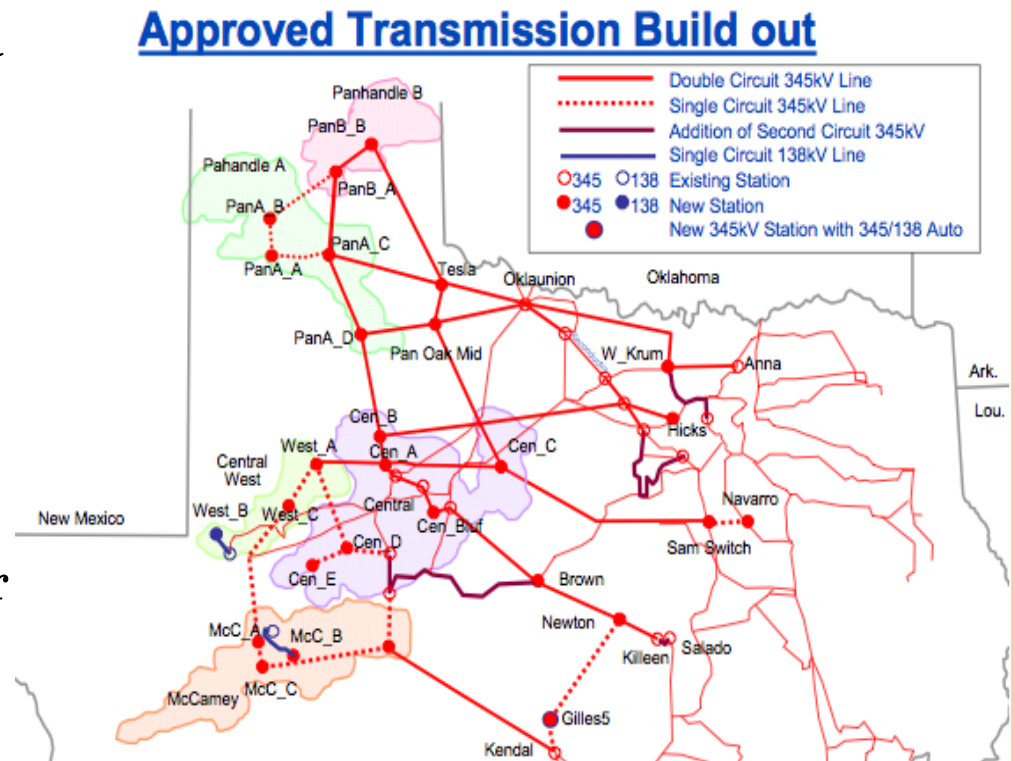

INTEGRATING RENEWABLES

Every study of renewable generation development potential and goals within the U.S. has concluded:

- 20, 30 and 35% renewables development are technically feasible if the transmission system is significantly expanded
- Major amounts of new transmission is required for every future wind development scenario in the Eastern and Western interconnections
- Costs for integrating large amounts of renewables are manageable with large amounts of transmission and large regional operating pools (including fast, flexible non-renewable generation); markets make it easier to get ancillary services easily and cost-effectively.

IMPROVE RELIABILITY, STRENGTHEN GRID

CALIFORNIA PATH 15 UPGRADE

- Path 15 is an 84-mi stretch of transmission through CA's Central Valley, built to deliver Pac NW hydropower south to CA and the SW.
 - Two 500kV lines (Los Banos- Gates, Los Banos-Midway)
 - Four 230kV lines (at Gates)
 - Total capacity was 3,900 MW, so it bottlenecked power flows into southern CA.
- After CA electricity crisis of 2000-2001, WAPA and Trans-Elect built a third 500kV line and a 5th 230 kV circuit to reduce the constraint, expanding south-to-north capacity to 5,400 MW in 2004.
- Trans-Elect financed the \$300 million upgrade and owns capacity rights

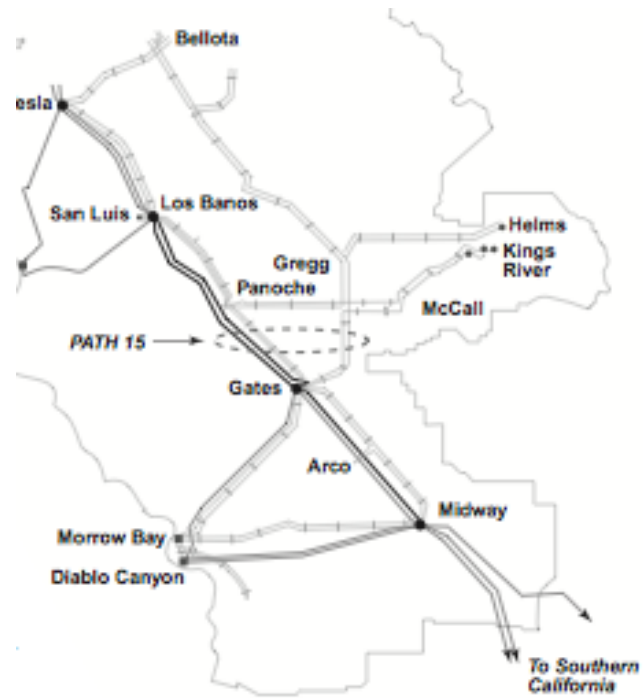

ACCESS ADDITIONAL RESOURCES TO REDUCE COST, DIVERSIFY RISK

SUNRISE POWER LINK

- Imperial Valley to San Diego, by SDG&E
- 117 mi, 500 kV line, 1,000 MW capacity for \$1.9 billion
- Will create transmission access for wind, solar, and geothermal resources
- Projected benefits of \$100 million/yr in net benefits to SDG&E customers

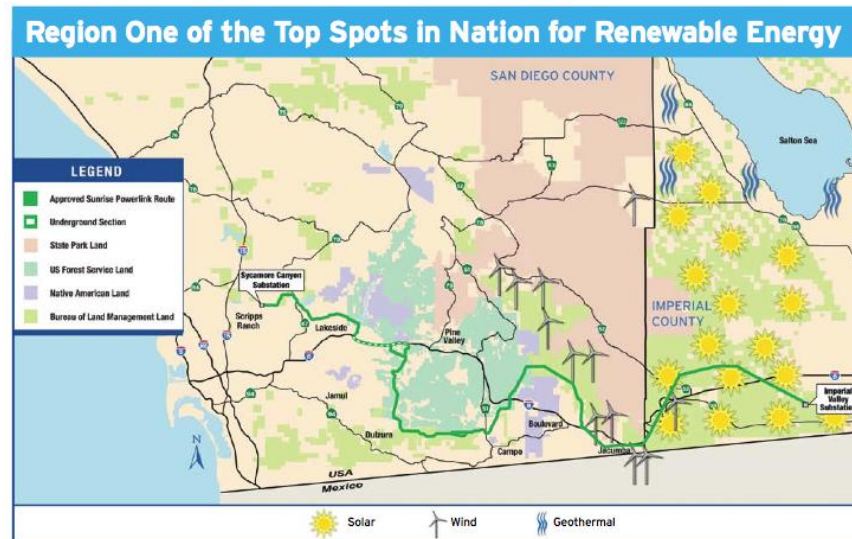

REDUCE CONGESTION, IMPROVE ECONOMICS

MISO REGIONAL TRANSMISSION EXPANSION

Midwest ISO estimates that its 2010 transmission expansion plan (231 projects, \$1.2 billion in new infrastructure on top of previously approved projects) will lower electric generation costs, lower delivered electricity costs (LMPs at loads), reduce energy and capacity losses, and reduce required reserve margins.

Table 1.2-1: 2015 Economic Benefits

Region	Load Cost Savings (\$M) ⁹	Adjusted Production Cost Savings (\$M) ¹⁰	Market Congestion Benefits (\$M) ¹¹
Midwest ISO East (Michigan, Northern Ohio, and Northern Indiana)	127	211	186
Midwest ISO Central (Central and Southern Indiana, Illinois, Missouri)	108	253	209
Midwest ISO West (Wisconsin, Iowa, Minnesota, North Dakota, and Montana)	760	288	430
Midwest ISO (Excludes portions of states in other RTOs)	995	752	825

INCREASE EFFICIENCY AND RELIABILITY

ONCOR SVCs

- Oncor added two Static Var Compensators in Dallas and Fort Worth to provide dynamic voltage control and mitigate power oscillations to improve reliability in ERCOT's largest load center.
- Through dynamic reactive power injection, SVCs can increase transfer capability and reduce line losses.
- Each SVC costs over \$50 million.



IMPROVE RELIABILITY, STRENGTHEN GRID REPLACE AGING INFRASTRUCTURE

Lots of today's EHV system was built in the 1960s and it isn't aging well.

- Steel thickness loss, metal fatigue and cracking
- Metal corrosion
- Deterioration of line splices and insulators
- Foundations and footings are deteriorating
- Transformers nearing or past end of useful lives

Unless these are fixed or replaced, failure by these structures or devices will cause big outages.

PJM 500 kV structure



4) BASIC TRANSMISSION LEVELS AND EQUIPMENT

- What is a transmission line?
- Transmission voltages
- Parts of a transmission line

WHAT IS A TRANSMISSION LINE?

- Wires between substations
- Can be constructed overhead or underground
- Transfers voltage between sources and loads, allowing current to flow

Energy (Watts) = V (Voltage) x I (Current in Amperes)

- Lines are rated for Voltage, Current, and Energy Transfer

Energy = throughput over time, e.g. kWh

Demand = maximum capacity at a point in time, e.g. peak kW

We design the grid to serve maximum expected peak demand reliably and cost-effectively

TRANSMISSION VOLTAGES

Standard US AC Transmission Line Voltages	
Nominal (kV-rms)	Maximum (kV-rms)
69	72
115	121
138	145
161	169
230	242
345	362
500	550
765	800

- Voltage >230 kV called Extra High Voltage (EHV)
- Lower voltages have higher line losses
- Not all voltages in every region; rest of world has different but similar voltage ratings
- China building new 1,100 kV lines

TRANSMISSION VS. DISTRIBUTION

Transmission:

- Bulk transfer of electrical energy
 - Generator to substation
 - Substation to substation
- Long distance
- High voltage (>69kV)
- Low loss
- Redundant and reliable
- About 10% of customer outage minutes due to G&T system problems – but those are big outage events

Distribution:

- Limited quantity of energy transferred
 - Substation to customer
 - Residential or business
- Short distance
- Low voltage (<69kV)
- Higher line losses
- Could be looped or radial
- About 90% of customer outage minutes due to distribution system, in small local events

MAJOR COMPONENTS OF AN OVERHEAD TRANSMISSION LINE

- Conductor
- Shield wire
- Insulators/hardware
- Structure
- Foundation
- Grounding

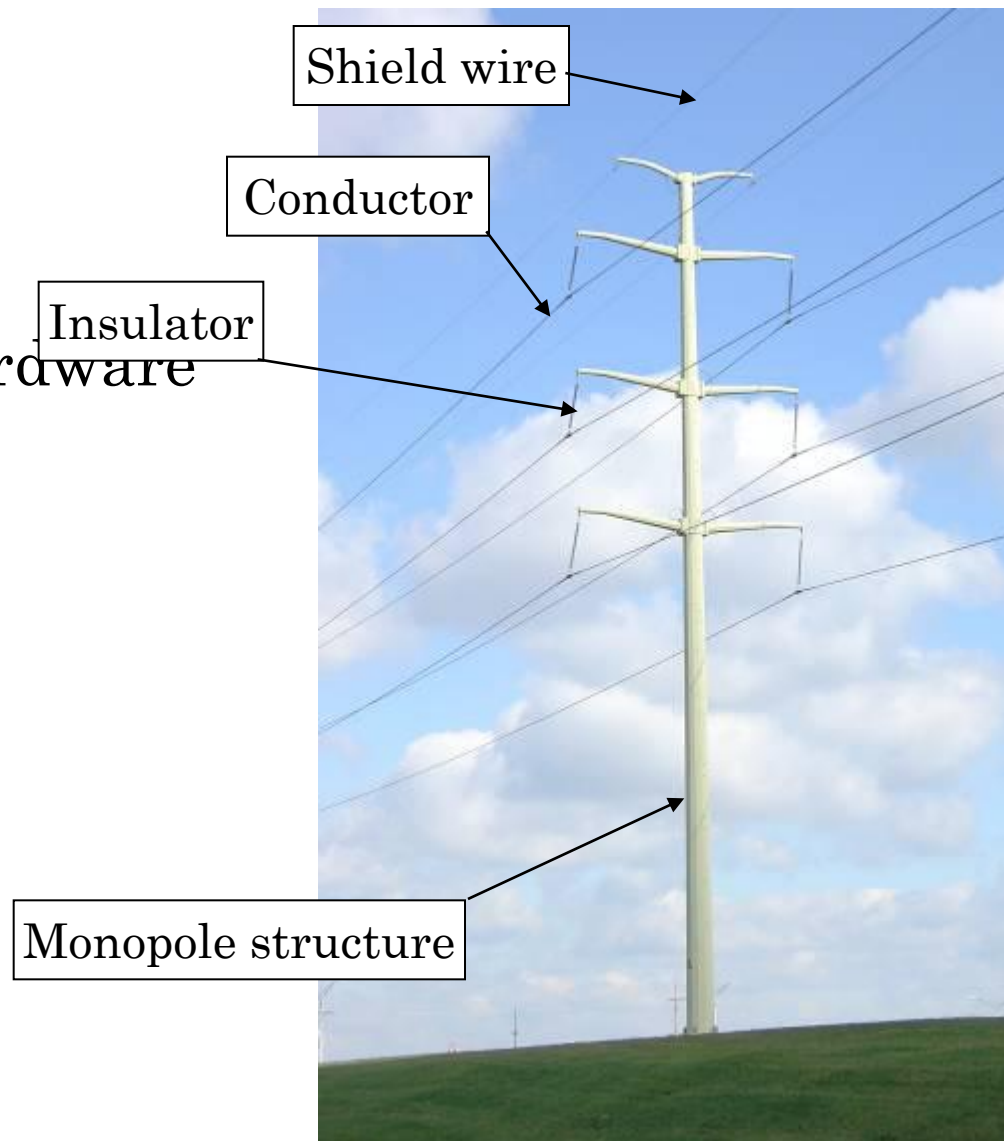

OVERHEAD TRANSMISSION LINES CAN BE



Single Circuit,

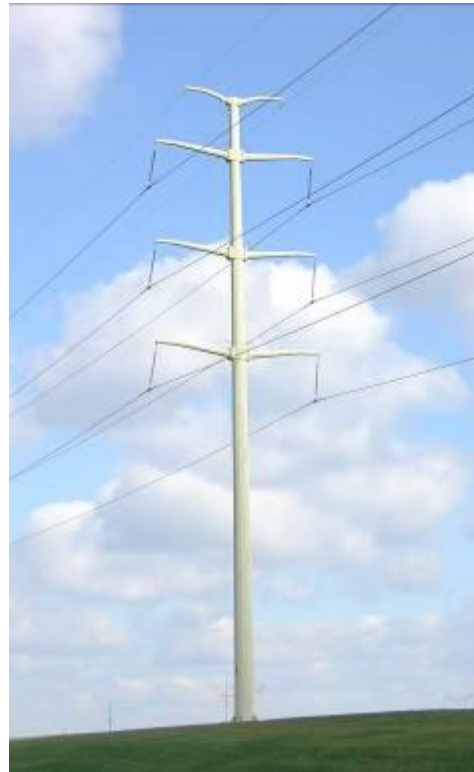

Double Circuit,



**Or Multiple
Circuit**

TRANSMISSION LINE RIGHT-OF-WAY (ROW)

- The strip of land the line is on
- Provides access for construction, operation and maintenance
- Conductor movement must be contained within ROW
- Higher voltages require wider ROWs
- ROW width controls much of line design
- Effective vegetation management in ROW is crucial



RIGHT-OF-WAY CROSS-SECTION

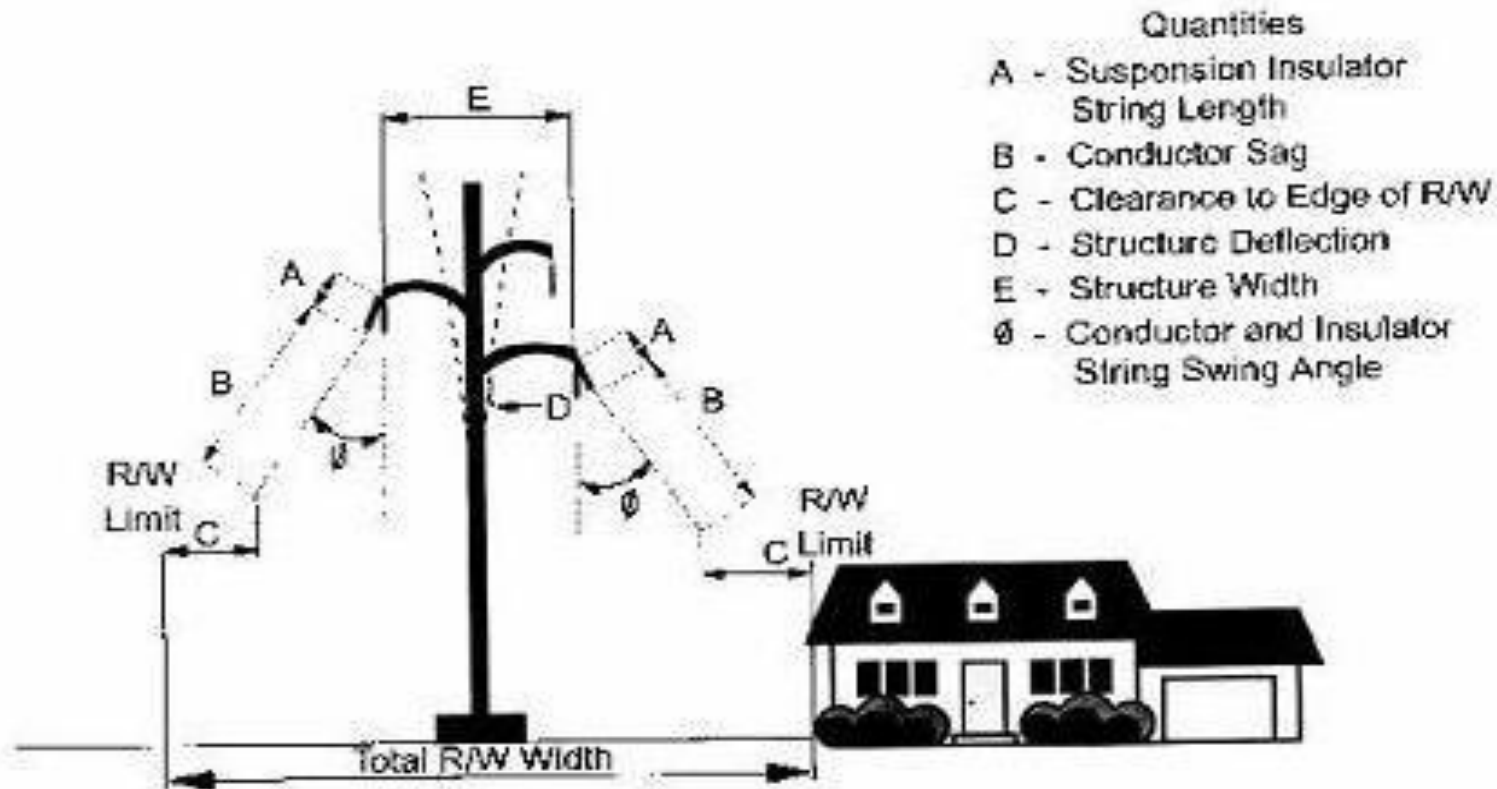

Electric lines sag lower as they carry more electricity, in hotter temperatures, and with ice loading. If utilities don't maintain and enforce (and regulators don't support) vegetation management and ROW easements, there are more outages and accidents due to sagging lines contacting trees and structures in the ROW.

TRANSMISSION VOLTAGES, STRUCTURES AND ROWs

Note: Approximate relationship based on Surge Impedance Loading (i.e. reactive power balance point) 345 kV/ single circuit tower lines with two conductors per phase compared to 765 kV single circuit lines with six conductors per phase.

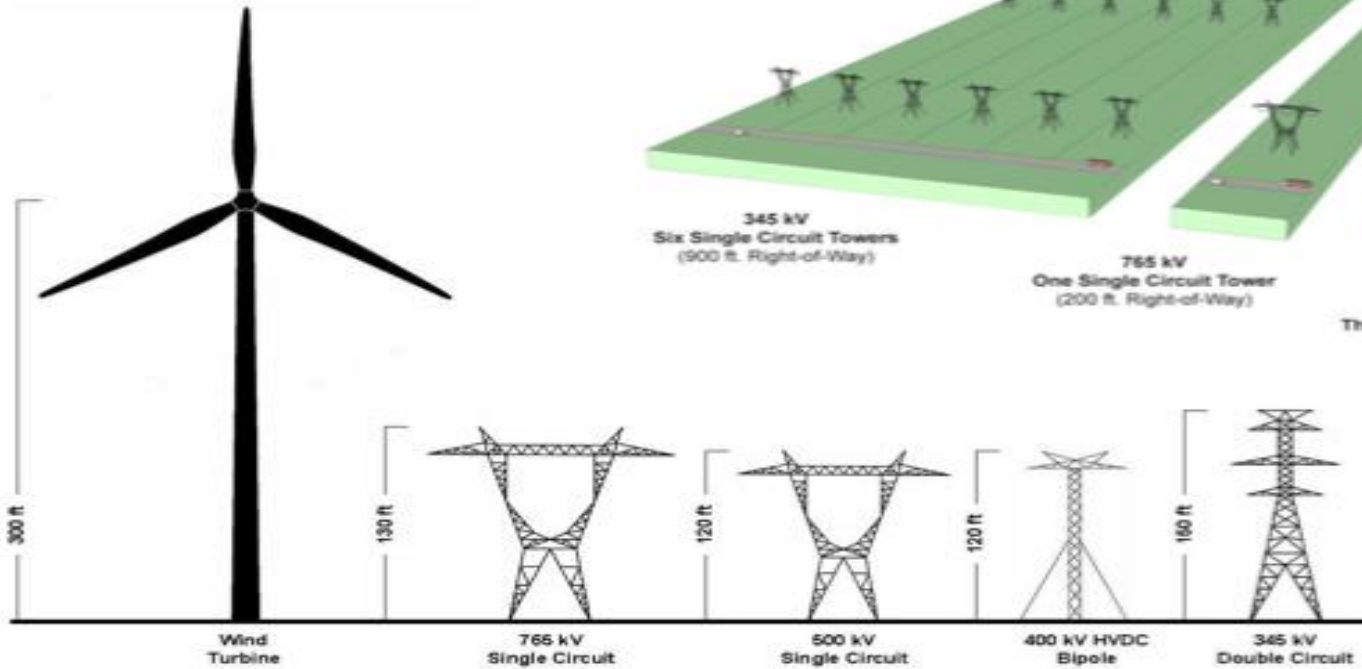
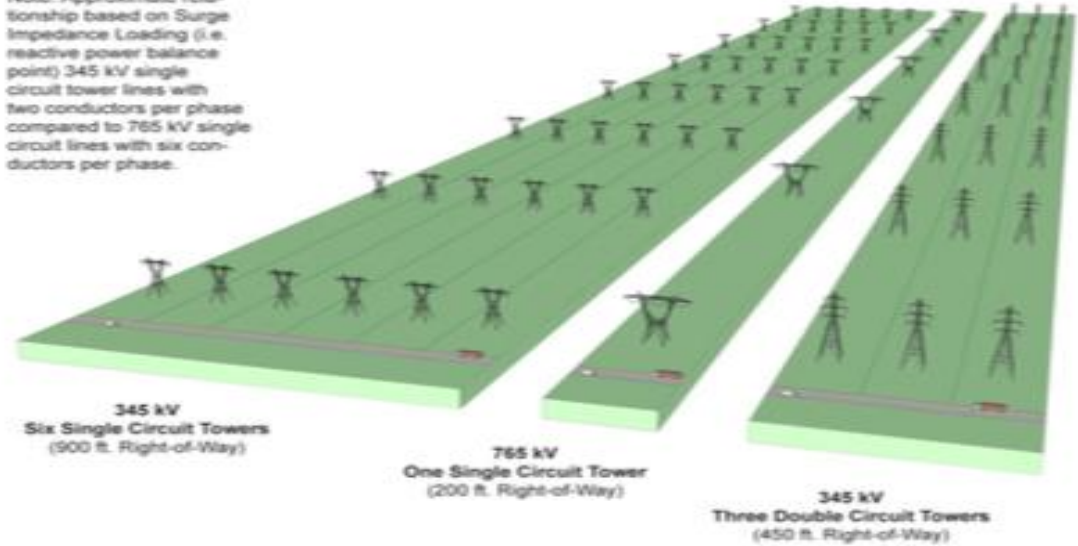

**Wind Turbines and Transmission Towers
Average Height of Structures**

- Higher voltages use ROW acreage more efficiently

DC TRANSMISSION

- DC links between AC lines and systems
- More expensive to build
- DC lines have few drop-off points
- DC has lower line losses, high efficiency
- Use DC, HVDC for long distances, high capacity

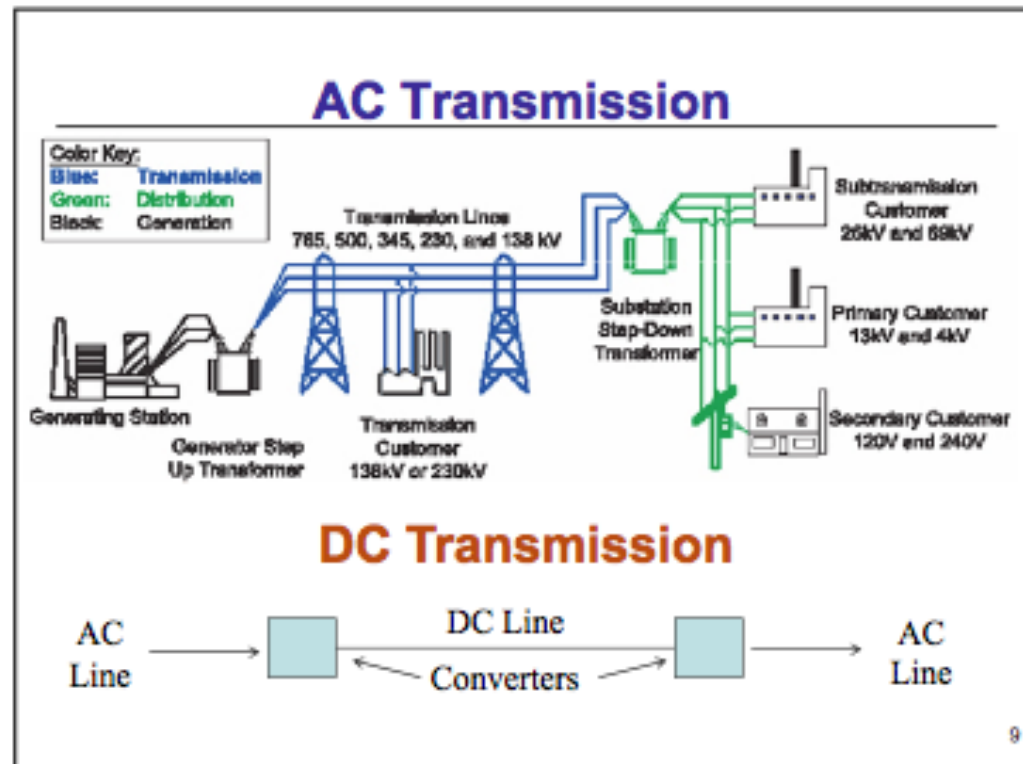

CONDUCTORS

- Copper used only for small distribution conductors
- Aluminum most common for transmission voltages
- Aluminum has about 60% of the conductivity of copper, but is much cheaper; good conductivity but poor strength
- Steel strands wrapped around aluminum add strength – ACSR (Aluminum Conductor Steel Reinforced) is the most commonly used conductor
- Conductor under higher tension sags less

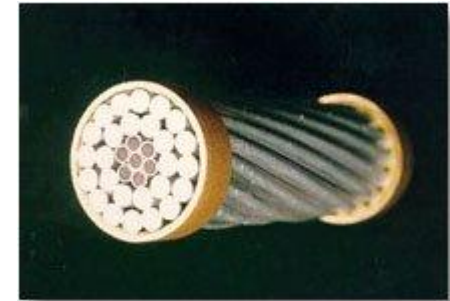

NEW CONDUCTORS

- Many newer competing technologies claim advantages
 - Low line losses
 - Low sag (high strength)
 - Withstand high temperature
 - Can operate safely at higher voltages
 - New materials
 - Lower cost/delivered energy
- Reconductoring can increase line capacity without building new lines

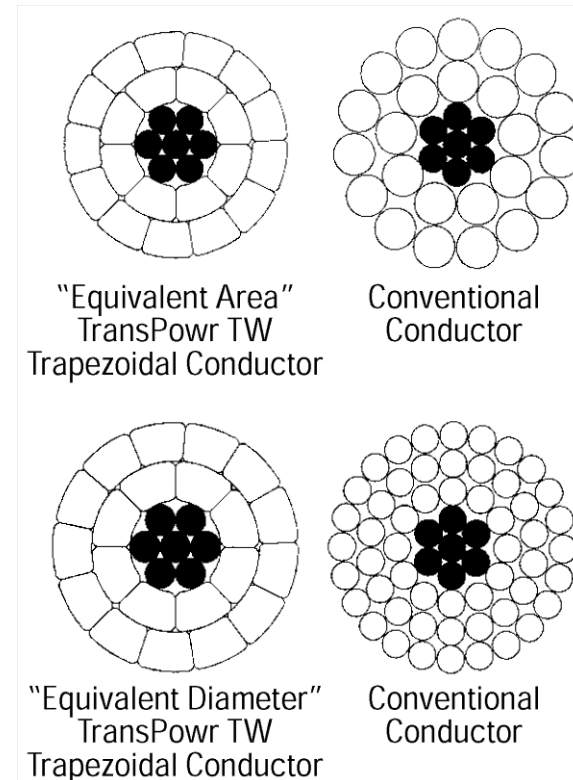

OVERHEAD TRANSMISSION VS. UNDERGROUND

Overhead:

- Low system loss
- Lower installation and maintenance cost
- Accessible for maintenance and problem-spotting
- Wider Right-of-Way
- Visually obtrusive
- Environmental concerns
- EMF/Corona concerns
- Higher likelihood of accident or attack

Underground:

- Shorter distances
- Increased system loss
- Higher installation and maintenance cost (10x cost differential)
- Harder to access for maintenance and repair
- Narrower Right-of-Way
- Visually inconspicuous
- Some environmental concerns
- Few EMF issues

TRANSMISSION COST

Transmission line construction cost varies by many factors:

- Voltage
- Overhead or underground (rule of thumb – undergrounding costs 10x as much as a comparable overhead line)
- Design specifics (e.g., structure types, number of phases, ROW width, whether you're over-building today to up-rate line later, strength requirements for local climate impacts)
- Route length
- Type and location of land (urban costs more than rural)
- Materials costs (type of conductor, steel v. concrete structures, amount of imported content and relative currency costs, component materials scarcity)
- Accommodations made to suit landowners and siting authorities (changes in structure type, route adjustments to meet environmental requirements, community needs or landowner demands)

TRANSMISSION COST ELEMENTS

Transmission capital costs include ROW land, materials, construction, regulatory and permitting, and substations

Transmission operating costs include operations and maintenance, vegetation management, taxes, insurance – total about 3% of capital cost

Transmission levelized cost in \$/MWh = capital cost plus O&M over lifetime (50 years), adjusted by line capacity (MW) and utilization factor (%)

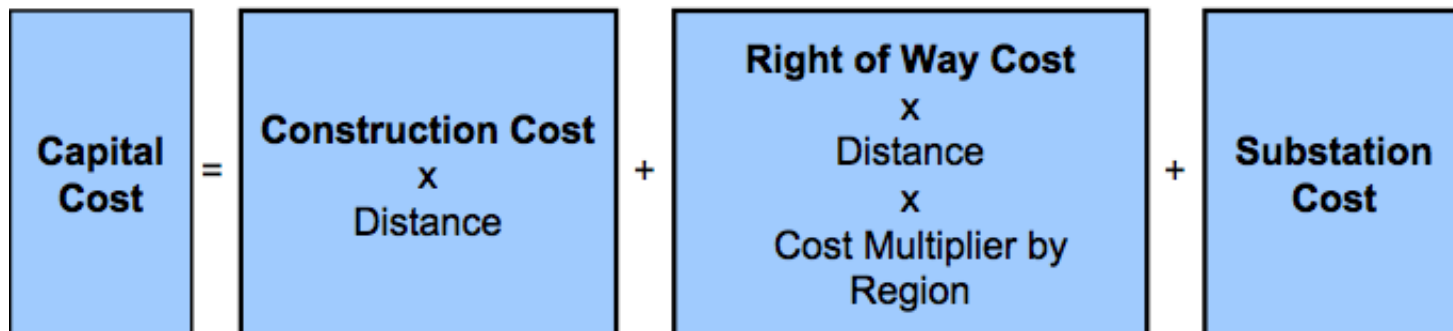

TRANSMISSION INTEGRATION COST

- When a new generator interconnects to the grid, it may have operational characteristics that require additional effort by operators to integrate that generation reliably into grid operations.
 - Relevant characteristics include dispatchability, intermittency, predictability, min and max operating levels, ramping speed, ability to operate on automatic control for ancillary services.
 - The grid operator uses ancillary services provided by other generators and demand resources to integrate generation.
- Some representative renewables integration costs (per WECC):
 - Wind -- \$5/MWh
 - Photovoltaic -- \$2.50/MWh
 - Solar thermal -- \$2.50/Mwh

5) PLANNING THE SYSTEM

TASKS IN PLANNING AND BUILDING A T LINE

- Project planning and control
- Licensing and environmental
- Conceptual engineering
- Detailed design
- Material procurement
- Construction contracts
- Construction management
- Engineering completion



LONG-TERM – PLANNING THE SYSTEM

- NERC estimates that U.S. summer peak demand could grow from 772 GW in 2010 to 870 GW by 2019 (1.34% annual growth rate).
 - Annual net energy to grow from 3,970 GWh to 4,613 GWh (1.57% /yr)
- Future resources (demand and supply) are expected to grow by approximately 100,000 MW from 2010 to 2019.
 - 131,000 MW planned capacity, about 85% available on-peak in 2019.

SOME UNCERTAINTIES FOR 2019

- Load

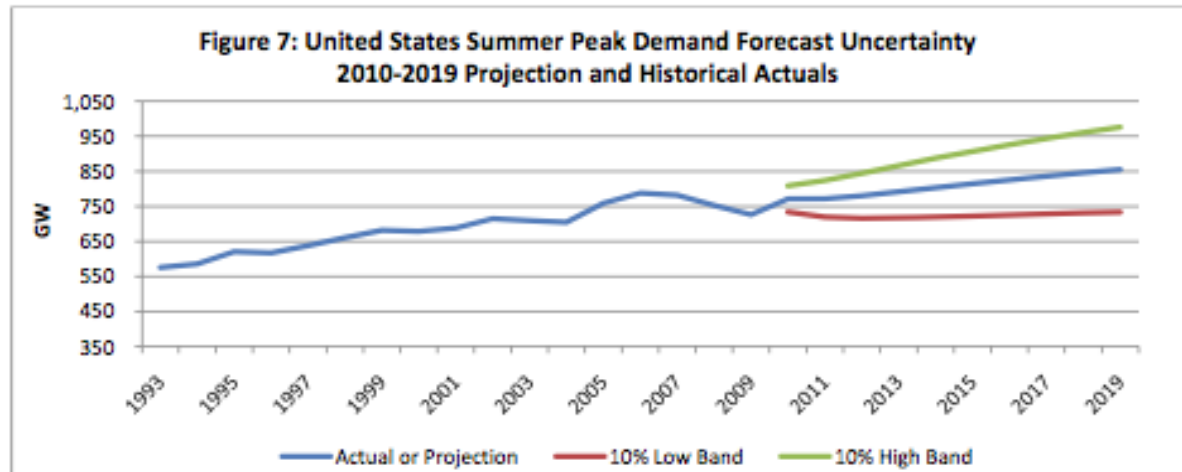

- Generation

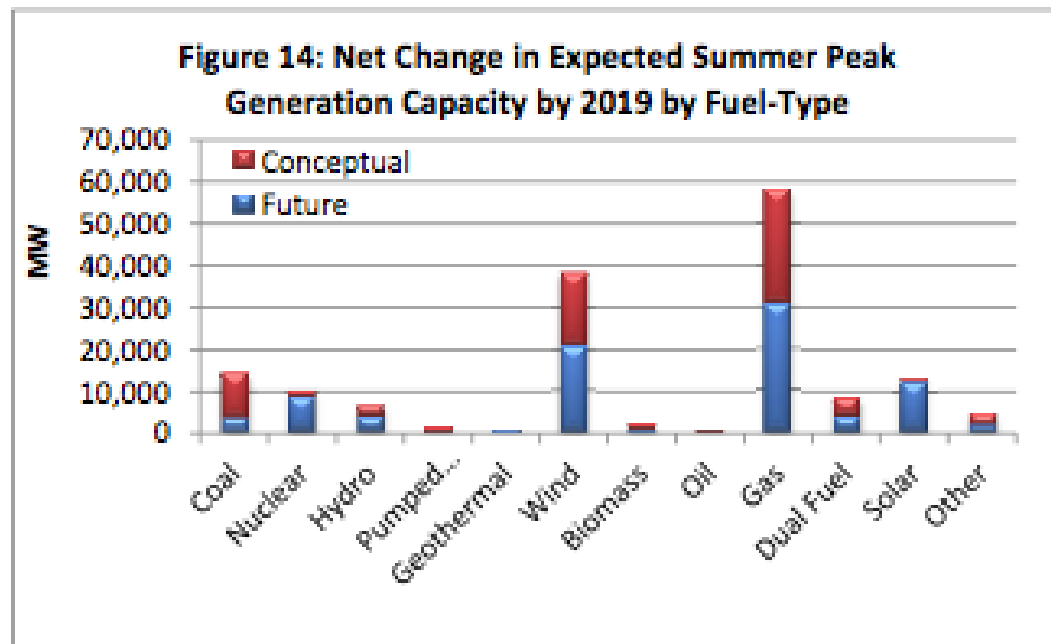

PLANNING CHALLENGES

How do you build transmission when you don't know:

- What will load be?
 - Where will load be?
 - To what degree will load be fixed and non-negotiable, versus dispatchable (controllable DR) or influenceable (rate-driven DR)?
- What generation will be available?
 - Technologies and fuels?
 - Operating range and flexibility -- baseload v. intermediate v. peaker; ramping speed; heat rate?
 - Wholly predictable and dispatchable (fossil plants, nuclear, geothermal, energy storage) or intermittent and variable with less predictability?
 - Fuel costs?
 - Generation locations?
 - Retirement of existing plants due to economics of fuel costs, heat rates or environmental regulation?
- Planning goals
 - Maintain or improve grid reliability
 - Connecting desired energy sources (renewables? low carbon?)
 - Foster an efficient electric system and market

Regional Planning Process

RTO/ISO planning encompasses the regional footprint; stakeholders can provide input and advocate positions throughout the process

Project is submitted to RTO/ISO for modeling to evaluate the impact on the regional system, including costs and benefits

If the data shows the project is beneficial based on the RTO/ISO's established criteria, it is approved

Approved projects are eligible for cost recovery according to the RTO/ISOs methodology

Projects may proceed outside the planning process but no cost recovery through RTO/ISO will be available

NEW LONG-TERM PLANNING EFFORT

DOE Interconnection-wide Long-term Planning grants under 2009 ARRA

- Stimulus Act set aside \$80 million for long-term (20-year) interconnection-wide transmission planning
 - \$60 million for Eastern, Western and ERCOT interconnection work by technical analysis teams informed by stakeholder groups
 - \$20 million for related technical studies and support by national labs
- Development of complex scenarios and sensitivity cases for future grid development paths reflecting alternate societal, policy, fuel cost and technology possibilities
- Use of economic and engineering models to simulate power plant development, grid operations and costs over the 20-year horizon for each scenario and sensitivity case
- With analytical results, stakeholders and planners can better understand dominant policy and economic drivers and consequences and design a more robust, reliable and economic power system.
- Full results in 2013; work to be continued thereafter

WHAT WE CAN LEARN FROM SCENARIO ANALYSIS (THINK GENERAL, NOT SPECIFIC)

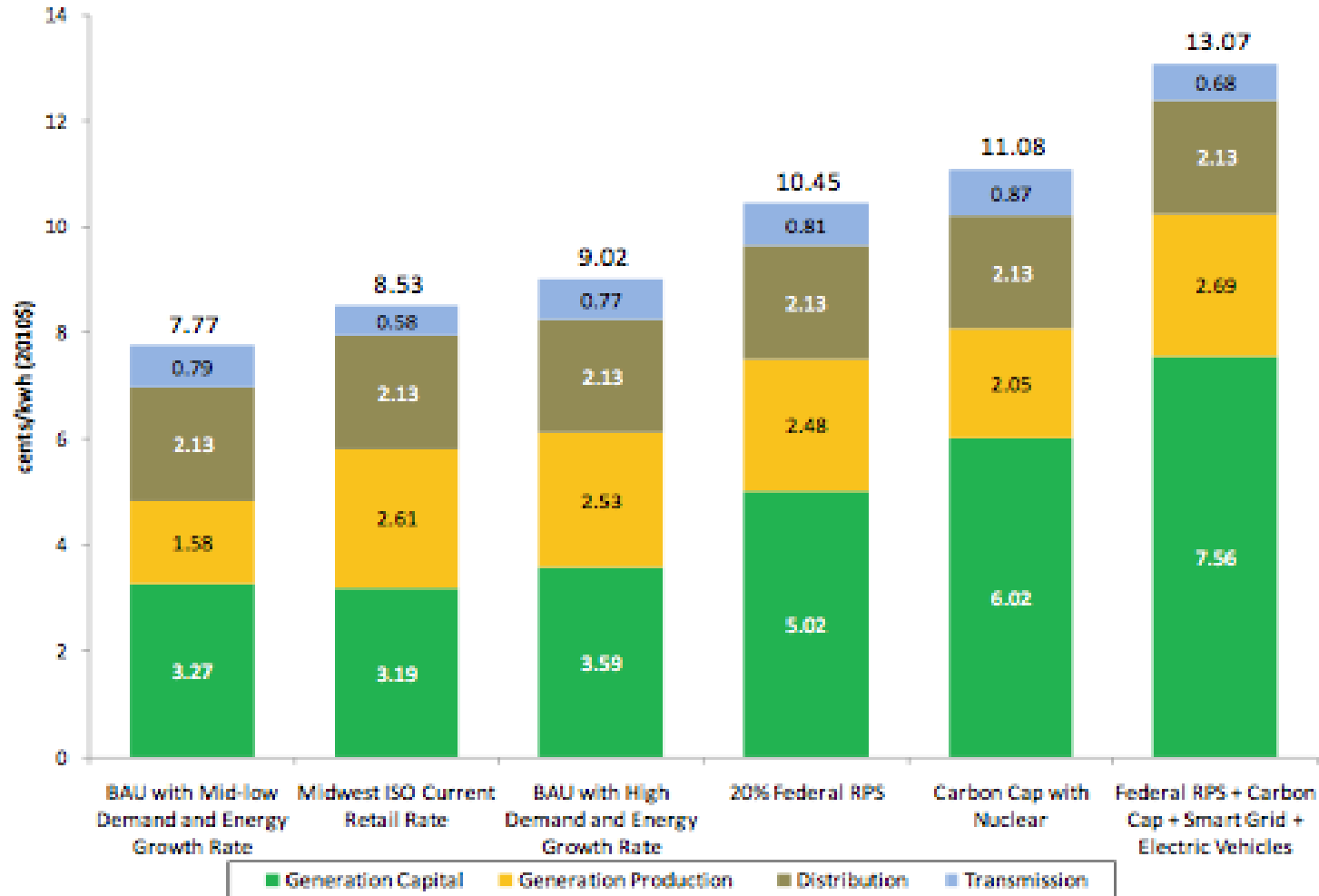

Figure 1.2-3: Comparison of Estimated 2025 Retail Rates for Each Future Scenario (cts per KWh in 2010 Dollars)

CHALLENGES FOR NEW TRANSMISSION

- Planning – what do we build, and when?
 - Which generation resources do we want to develop, and where?
 - What's the best timing to get new generation and transmission?
 - What types of transmission are flexible and cost-effective in the face policy, economic, societal and technology uncertainties?
- Cost allocation and recovery – who's going to build it and who's going to pay for it?
 - Who bears the costs and who gets the benefits of generation and transmission development?
- Siting and routing – where do we put new generation and transmission, and how do we resolve it faster and cleaner?
- Clear, unambiguous, long-term regional or national policies are necessary to establish certainty for major transmission investment and to move projects from plans into reality.

TRANSMISSION DELAYS

- NERC reports that a majority of new transmission projects are reporting delays of up to 3 years from permitting, siting, litigation, and other causes.
- Permitting time for a major transmission line has doubled from 3-4 years to 10 years or more (particularly for environmental and land use reviews and approvals)
- See NEMA's "Transmission Chutes and Ladders" at [http://www.wiresgroup.com/images/NEMA on Siting Trans Corridors Fall 2010.pdf](http://www.wiresgroup.com/images/NEMA_on_Siting_Trans_Corridors_Fall_2010.pdf)

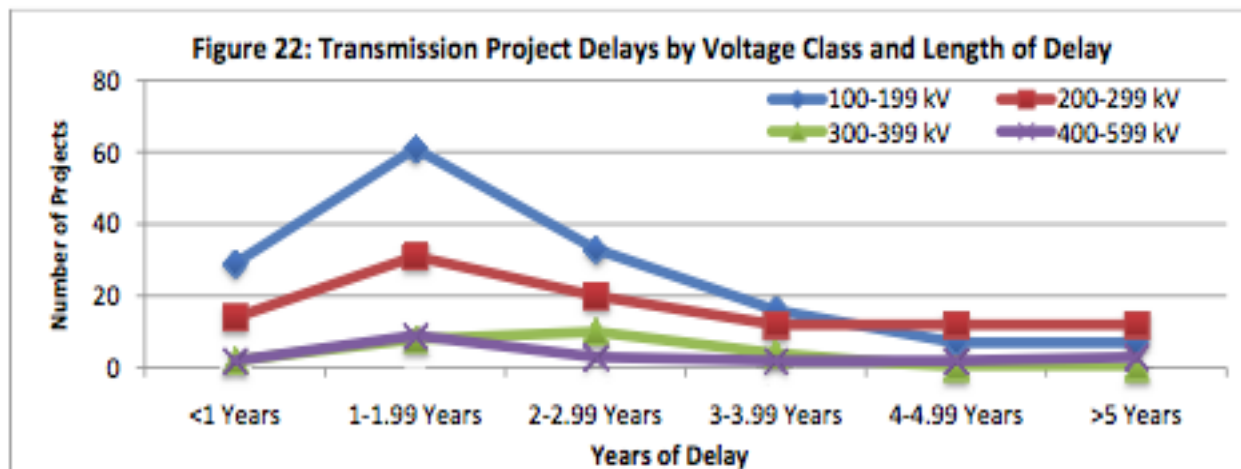

6) CLOSING THOUGHTS

- It's difficult to build transmission, and it isn't getting any easier.
 - Delays
 - Uncertainty
 - Grid operation becomes harder as generation characteristics change
 - Load's growing and generation's growing but transmission isn't keeping up, so maintaining reliability gets harder.
- There are alternatives to transmission, but they don't have the same regional-scale impacts as transmission and are not always easier
 - Non-wires solutions like efficiency, demand response, energy storage and distributed generation
 - Local generation near loads
 - Grid modernization (transmission and distribution automation, power electronics, synchrophasor technology, voltage management devices, reconductoring)
- Possibilities
 - New interstate EHV (765kV and up) and HVDC backbone
 - More classic transmission
 - More outages and higher energy costs

THANKS FOR THE HELP!

- Miles Keogh, NARUC
- Ivy Butts, NARUC
- Don Mundy, Black & Veatch
- Jeff Fleeman, AEP
- Jeff Hein, NREL

ADDITIONAL BACKGROUND

- EHV voltage comparisons
- Line losses
- Transmission services

EHV TRANSMISSION COMPARISON

Description	Line Voltage (kV)			
	765	500	345	345
Circuits per Tower	1	1	1	2
Conductors per Phase	6	3	2	2
Surge Impedance Loading (SIL) in MW *	2400	910	400	800
# Tower/Lines (100mi) for 2400 MW Capacity	1	3	6	3
ROW per line (ft)	200	200	150	150
Total ROW (ft)	200	600	900	450
ROW utilization factor	100%	38%	22%	44%
Typical Height (ft)	130+	120+	110+	150+
Cost/Mile (\$MM) for 2400 MW capacity **	2.6	6.9	6.6	4.5
Forced outage rate per circuit (per 100mi-yr)	1.0%	1.4%	1.6%	1.6%
"Reach" in mi (@1500 MW w/o compensation)	550	140	50	110
Combined Loss @ 1000 MW load/100 mi	0.5%	1.3%	4.2%	2.1%

* SIL is a relative capacity measure; thermal capacity is over 4000 MW for 765 kV and over 2000 MW for 500 kV

** Cost in 2007 US Dollars, based on average terrain (*gently rolling hills*); includes land costs

TRANSMISSION CAPITAL COST BY VOLTAGE

	Capacity (MW)	Cap Cost \$000/mile	ROW Width feet	Phase/Pole Current (amps)	Typical Conductors	No. of Conductor per phase	Resistance Per Cond (ohms/mile)	FLL* (MW/mile)	FLL* Per 100 miles	Losses at 60% Utilization % per 100 miles
765 kV AC Single	3000	2250	200	2383	957 ACSR	6	0.1086	0.30843	0.01028	0.00454
500 kV AC Single	1500	1800	175	1823	1590 ACSR	3	0.0666	0.22139	0.01476	0.00708
500 kV AC Double	3000	2880	175	1823	1590 ACSR	3	0.0666	0.44277	0.01476	0.00708
345 kV AC Single	750	1260	160	1321	795 ACSR	2	0.128	0.33513	0.04468	0.02145
345 kV AC Double	1500	2016	160	1321	795 ACSR	2	0.128	0.67027	0.04468	0.02145
230 kV AC Single	400	900	150	1057	1272 ACSR	1	0.0828	0.27749	0.06937	0.03330
230 kV AC Double	800	1440	150	1057	1272 ACSR	1	0.0828	0.55498	0.06937	0.03330
500 kV DC Bi-Pole	3000	1440	200	3000	1780 ACSR	3	0.0609	0.36540	0.01218	0.00585
800 kV DC Bi-Pole	TBD	TBD	TBD	2813	1780 ACSR	3	0.0609	0.32115	0.00714	0.00343

Table from WREZ Model Methodology Report, 2010



SUBSTATION CAPITAL COSTS

Line Size	Substation Capital Cost (\$000s)
765 kV AC Single	62,500
500 kV AC Single	50,000
500 kV AC Double	80,000
345 kV AC Single	40,000
345 kV AC Double	64,000
230 kV AC Single	35,000
230 kV AC Double	56,000
500 kV DC Bi-Pole	250,000
800 kV DC Bi-Pole	TBD

Table from WREZ Model Methodology report, 2010

TRANSMISSION LINE LOSSES

- If 100 MWh are generated at the power plant, on average only 93 MWh of that energy gets through the transmission and distribution system to the end user.
 - Average line losses = 1-2% for EHV transmission, 2-4% overall lines and substations
 - Average line losses = 4-6% for distribution
 - Line losses at peak are higher – can be 10-15% due to higher resistance and reactive power consumption
- Delivered electricity cost after losses =

$$\frac{\text{Cost at Busbar (\$/MWh)} + \text{Transmission Cost (\$/MWh)}}{(1 - \% \text{ Transmission Loss})}$$

FUN FACT: Joule's Law – energy losses are directly proportional to the square of the current; higher voltages reduce current and thus reduce resistive losses. Line losses are dissipated as heat; hot conductors sag lower, which is why transmission lines have thermal constraints.

“TRANSMISSION SERVICES”

“Transmission service” encompasses a suite of functions (**ancillary services**) provided by grid operators or generators, that are needed for grid reliability:

- **Scheduling** – before-the-fact assignment of generation and transmission resources to meet anticipated loads
- **Dispatch** – real-time control of all generation and transmission resources to meet load and maintain reliability
- **Regulation** – automated control of on-line resources to respond rapidly to operator requests for increased or decreased generation, to correct minute-to-minute fluctuations by load and generation and maintain system frequency within required range around 60 Hz. Also called frequency response. Can be provided by some automated demand response and storage technologies.
- **Spinning reserve** – extra capacity available by increasing the output of generators already on-line. Like regulation service, but over longer periods (e.g., 10-30 minutes). When called energy imbalance service, serves a financial settlement function in clearing spot markets. Can be provided by demand resources.
- **Replacement reserve** – provided by off-line resources available within 30-60 minutes, that can be used to replace or supplement frequency control reserves to restore system stability. May be called supplemental or non-spinning reserve service. Can be provided by demand resources, imports, or curtailment of exports.
- **Voltage control** – injection or absorption of reactive power to maintain transmission system voltages within required ranges. Provided by generators or transmission equipment like SVCs and capacitor banks.
- **Black start** -- generators that can self-start without grid support

BEWARE – ancillary service names and definitions vary across balancing authorities and experts



TRANSMISSION SERVICES BY COST

PJM Wholesale Cost (2009 \$/MWh)

