

Transmission Mounted Parking Brake Disassembly

NOTE: To replace the brake assembly, brake shoe and lining assemblies, or other operational components the complete parking brake assembly must be removed from the vehicle.

1. Remove the parking brake assembly.
2. Remove the 4 bolts holding the yoke flange and drum. Remove the yoke flange and drive.

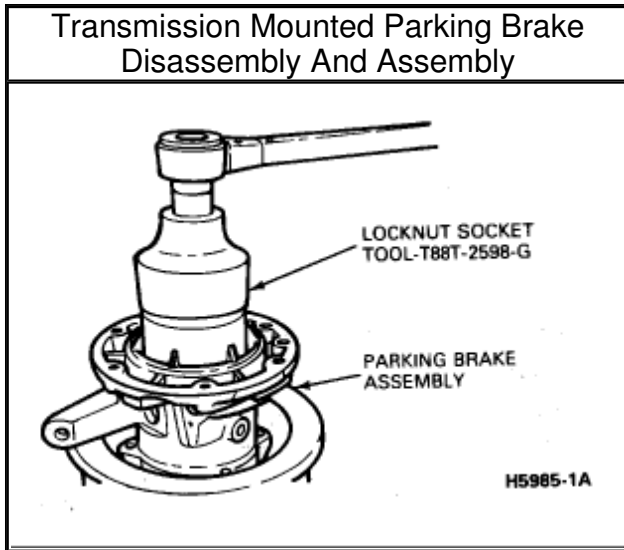

Zoom

Sized for Print

3. Using Tool T88T-2598-G remove the **75mm** hex locknut from the mainshaft.
4. Using a suitable press, remove the mainshaft [brake drum](#) and output flange out of the case assembly.
5. Remove the snap ring retaining the speedometer drive onto the shaft. Remove the speedometer drive gear.
6. Using puller D8OL-1002-2 with bearing cone remover D79L-4621-A and stop plate D8OL-630-6, remove the outer bearing cone from the mainshaft.
7. Remove the output shaft and brake assembly from the vise. Turn the shaft assembly over and put the threaded end in the vise. Be sure to use soft jaw inserts to protect the mainshaft.

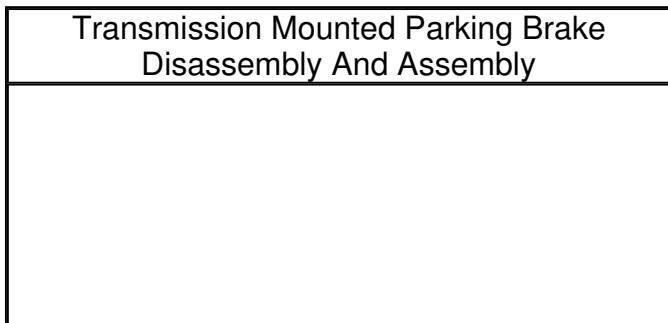

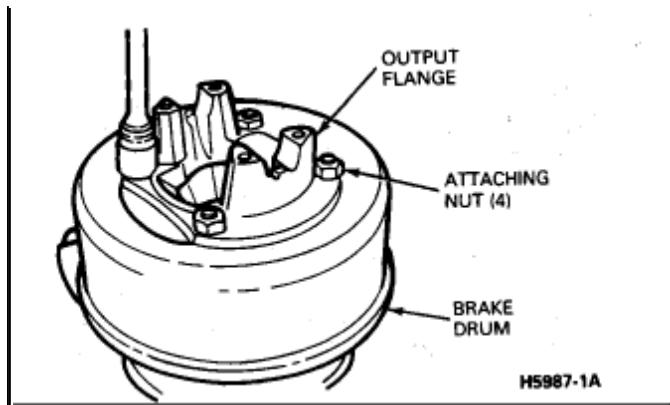

Zoom

Sized for Print

8. Remove the 4 hex nuts attaching the flange and [brake drum](#) to the output shaft. Remove the drum and flange from the output shaft. **NOTE:** The drum, yoke/flange, and mainshaft are balanced as a unit, and must be marked to assure that they are assembled in the same position. Leave the bolts in the output flange.
9. Remove the input shaft oil seal, spacer, O-ring, bearing cone assembly and bearing cup from the input shaft end of the case using tool number T77F-1 102-A, or equivalent.

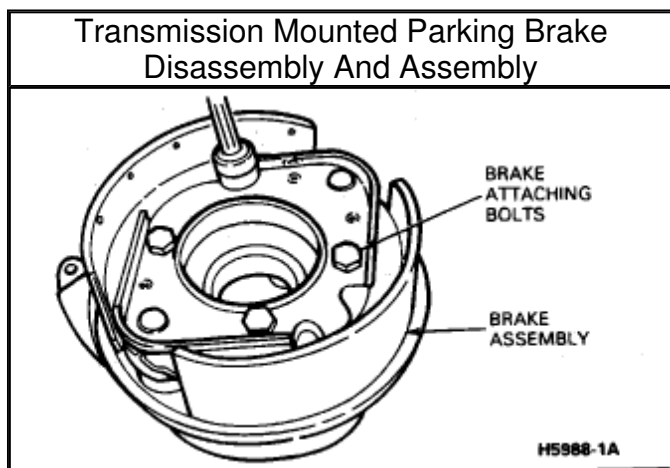

Zoom

Sized for Print

10. Remove the 4 bolts attaching the splash shield and brake assembly to the case. Remove the brake assembly and splash shield from the case.
11. Remove the brake actuating lever and the lever spring from the case. **NOTE:** For brake assembly component repair, refer to brake component repair.

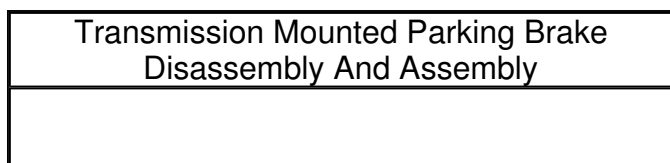

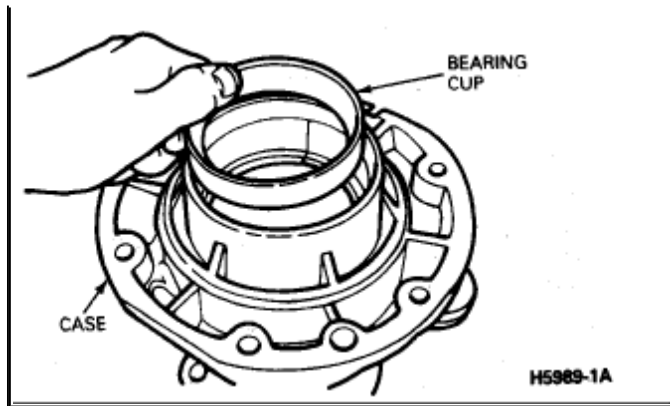

Zoom

Sized for Print

12. Using tool T77F-1 102-A remove the outer bearing cup. The bearing removal will remove the oil seal.
13. Unscrew and remove the vent from the case.

Brake Shoe Disassembly

1. Holding the brake assembly securely. Remove the two [brake shoe](#) return springs using a suitable brake spring tool.
2. Spread the free ends of the [brake shoes](#) apart and remove the brake shoes from the lower anchor pin. Remove the shoe-to-shoe spring.

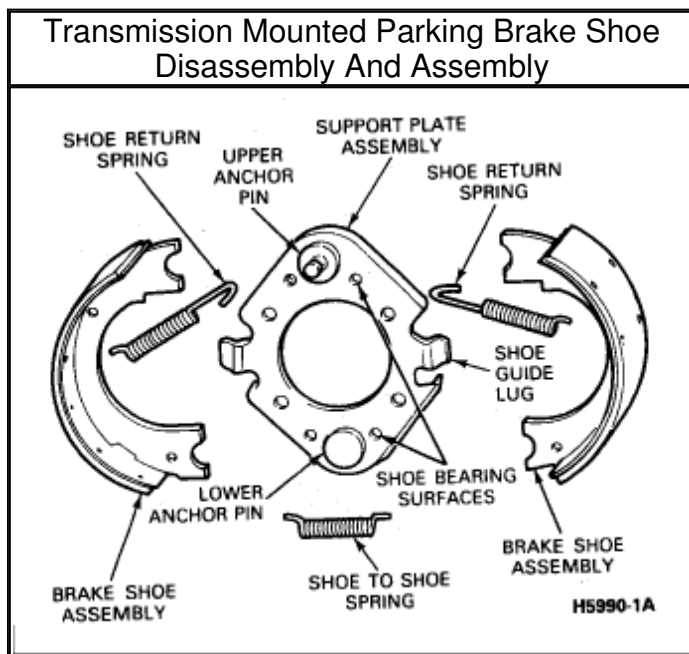

Zoom

Sized for Print

3. Clean any grease or contamination from the support plate. Remove contamination

- from the shoe guide lugs and other shoe bearing surfaces with sand paper.
4. Coat the following areas with Ford Disc Brake Caliper Slide Grease D7AZ-1g590-A. Use only a light application of grease at these points.
 - Camshaft lugs and ball of actuating lever.
 - Shoe guide lugs and shoe bearing points of the support plate assembly.
 - Upper and lower anchor pins.
 - Anchor pin contact points of the [brake shoes](#).

[Brake Shoe](#) **Assembly**

1. Using new brake shoe and lining assemblies, install new shoe-to-shoe springs into the lower holes of the [brake shoes](#).
2. Spread the opposite ends of the shoes and assemble the lower ends of the shoes over the shoulder of the lower anchor pin, twisting the shoes into position. Move the upper ends of the shoes to the upper anchor pin, inserting the shoe webs between the shoe guide lugs and the bearing surfaces of the support plate.

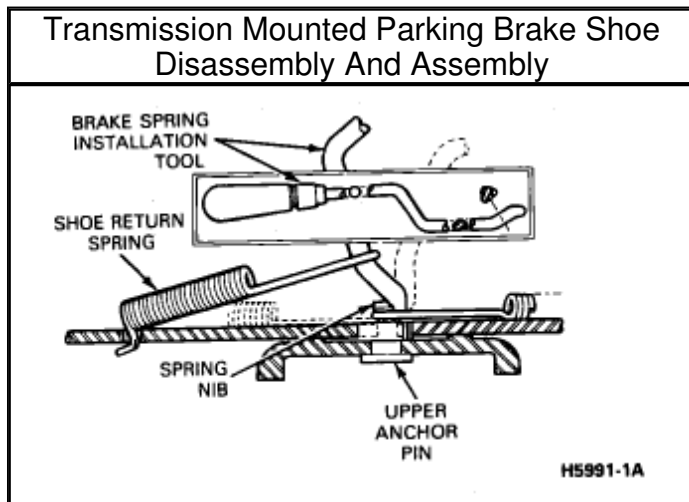

Zoom

Sized for Print

3. With the upper ends of the shoes against the upper anchor pin, install two new shoe return springs. Install the short hooked end of each spring into the upper holes of the [brake shoes](#) and hook the opposite end of each spring over the anchor pin nib, using a suitable spring installation tool. Be sure the open end of the spring hook faces toward the brake centerline.

Transmission Mounted Parking Brake Assembly

1. Press the plug into the output flange if plug was previously removed. Apply sealer to the lip of the plug. Press into place with the lip of the plug facing outward. The plug must be flush with the edge of the bore.

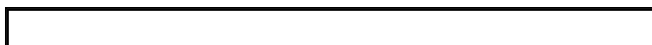

Transmission Mounted Parking Brake Disassembly And Assembly

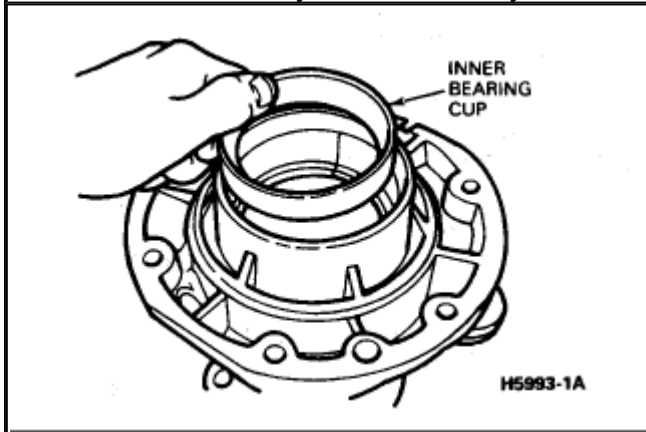

Zoom

Sized for Print

2. Install the inner bearing cup into the bore in the case using tool T88T-2598-D, or equivalent. Press the cup into the case until it bottoms in the bore.
3. Turn the case over and install the outer bearing cup into the case. Press in using tool T88T- 2598-E (or equivalent) until the bearing cup bottoms in the bore.
4. Install the outer bearing cone assembly into the cup.

Transmission Mounted Parking Brake Disassembly And Assembly

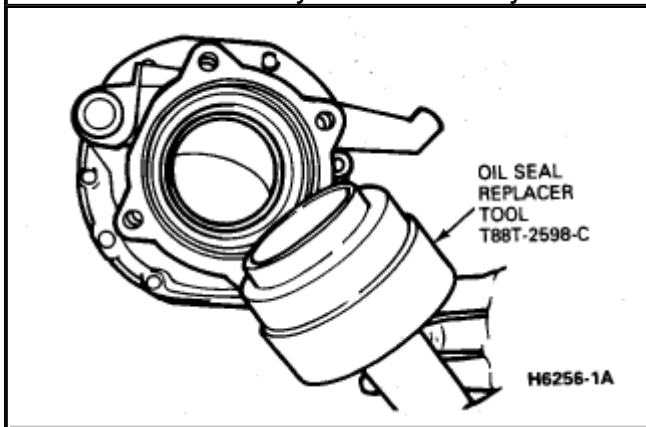

Zoom

Sized for Print

5. Apply a light coating of sealer to the outer edge of the outer oil seal. Position the oil seal in the bore of the case with the sealing lip facing inward. Press the seal into the bore of the case using tool T88T-2598-C, or equivalent. Press the seal in flush with the bore surface.

Transmission Mounted Parking Brake Disassembly And Assembly

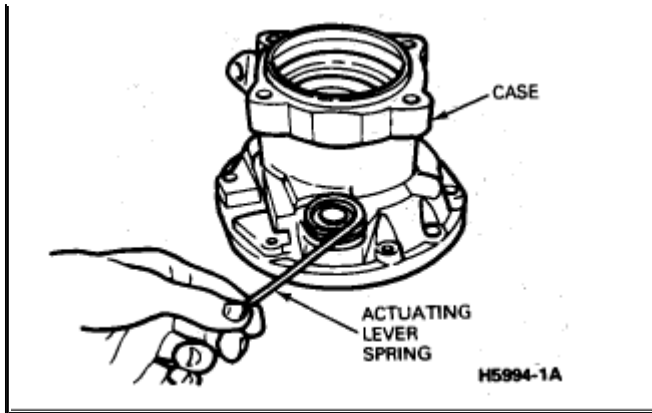

Zoom

Sized for Print

6. Install the actuating lever spring in the boss in the case.

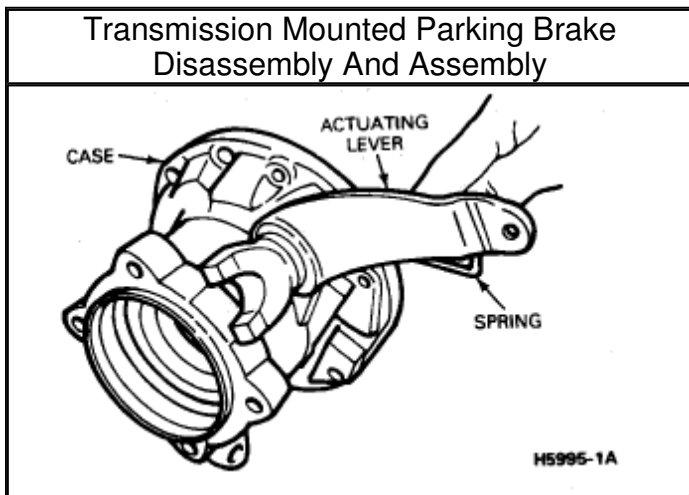

Zoom

Sized for Print

7. Apply a light coating of Ford Disc Brake Caliper Slide Grease D7AZ-19590-A, or equivalent to the ball of the actuating lever. Install the lever (ball end) into the hole in the boss of the case, through the coiled end of the spring.

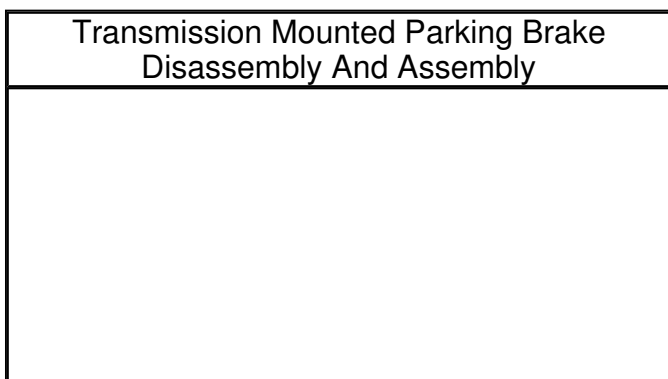

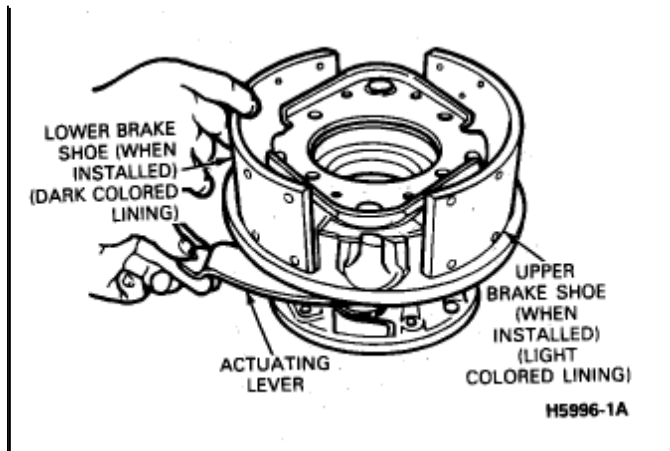

Zoom

Sized for Print

8. Position the [backing plate](#) and brake assembly into position on the case. Insert the actuating lever (cam end) into position in the brake assembly.
9. Attach the brake assembly and [backing plate](#) to the case with 4 hex head bolts. Tighten the bolts to **118-122 Nm (87-91 ft-lb)** . Attach retracting spring to the actuating lever while bending the long end to snap over the lever.
10. Place the mainshaft in a vise with the flanged end up. Protect the shaft with soft jaw inserts.
11. Install the [brake drum](#) and output flange onto the flange end of the mainshaft.

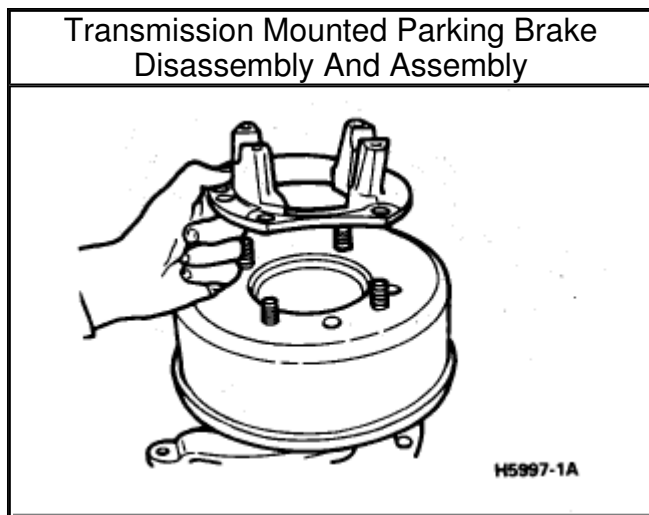

Zoom

Sized for Print

12. Install the output flange onto the [brake drum](#), aligning the marks made during disassembly (to insure that the balance is not disturbed). Install the 4 hex nuts and tighten to **113-117 Nm (83- 87 ft-lb)** .
13. Remove the mainshaft with brake assembly from the vise. Turn the unit over and clamp it securely in the vise.
14. Install the case, with the outer bearing cone installed loosely onto the mainshaft

- guiding the shaft through the oil seal and bearing cone.
15. Install the outer bearing cone onto the mainshaft using tool T88T-2598-F or equivalent, seat the bearing on the shaft.

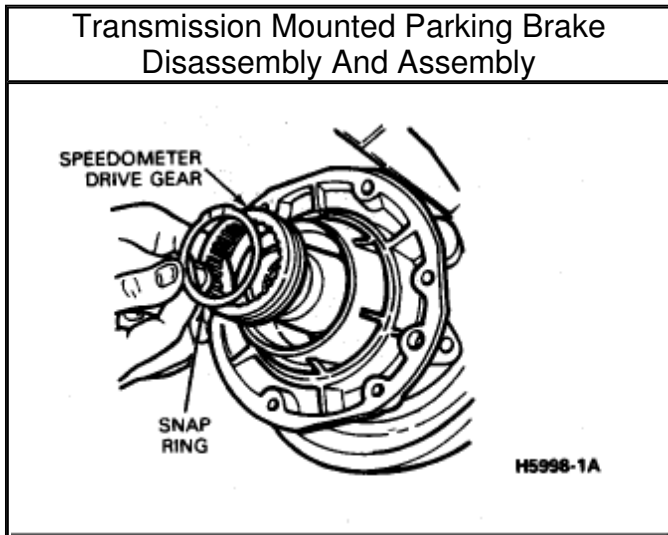

Zoom

Sized for Print

16. Install the speedometer drive gear onto the mainshaft. Install the snap ring into the groove locking the speedometer gear to the shaft.

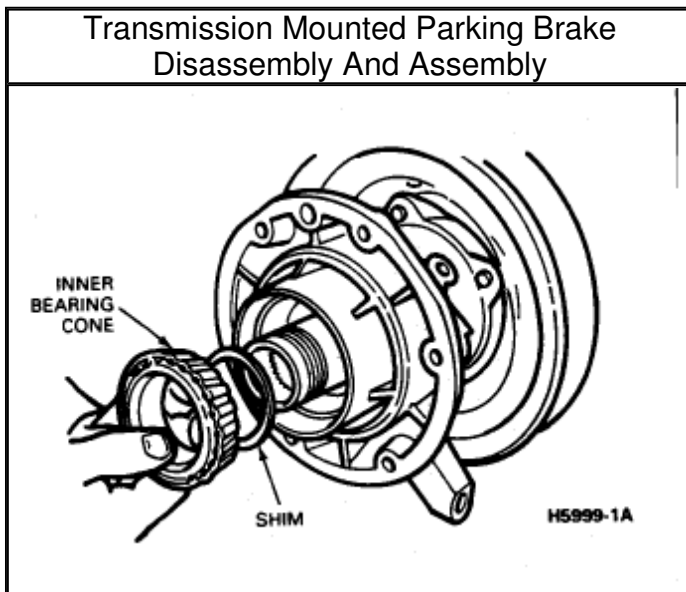

Zoom

Sized for Print

17. Install the shim on the mainshaft. **NOTE:** This shim determines mainshaft end play, and it is available in thicknesses in variances of **0.0019 inches**.
18. Install the inner bearing cone onto the mainshaft. In order to measure mainshaft

end play, install the bearing spacer without the O-ring onto the mainshaft.

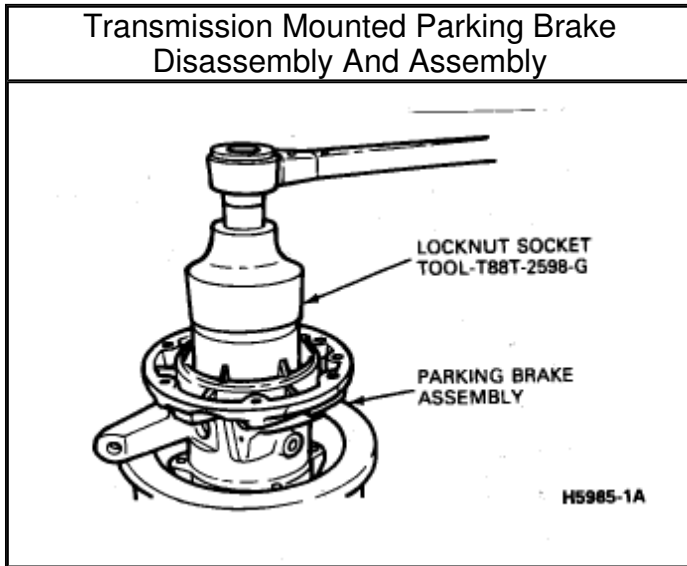

Zoom

Sized for Print

19. With the case assembly and mainshaft clamped firmly in the vise, screw the hex locknut onto the mainshaft. Tighten the nut to **288-292 Nm (212-216 ft-lb)** .

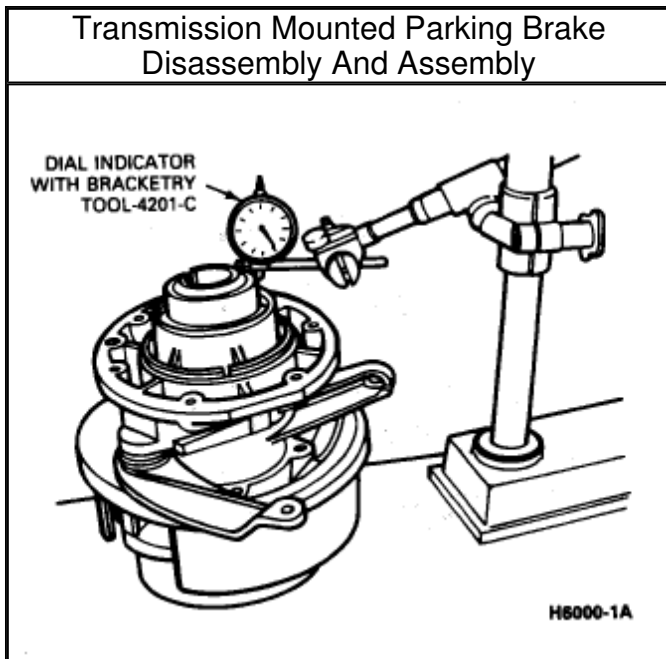

Zoom

Sized for Print

20. Mount a dial indicator between the mainshaft and the case to check end play. Use dial indicator with bracketry Tool-4201-C or equivalent.

21. While rotating the case assembly on the mainshaft to center the bearings. Apply pressure up and down while taking an end play reading. A reading of **0.0019-0.0039 inches** is required. If the reading is not to specification, a thicker or thinner shim must be used.
22. Remove the locknut and the bearing spacer from the shaft.
23. Remove the inner bearing cone and add the necessary additional shims to obtain the specified end play.
24. Reinstall the inner bearing cone on the shaft.

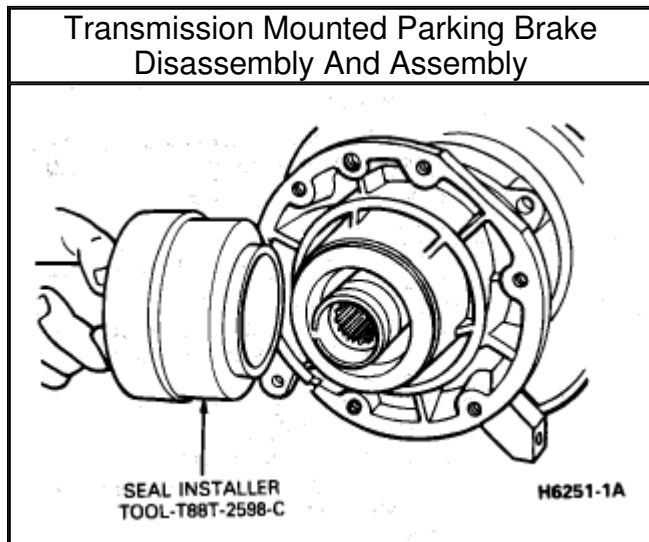

Zoom

Sized for Print

25. Coat the outer shell of a new inner oil seal with sealer and install it in the bore of the case until it seats inside the bore. The sealing lip of the seal must face inward.

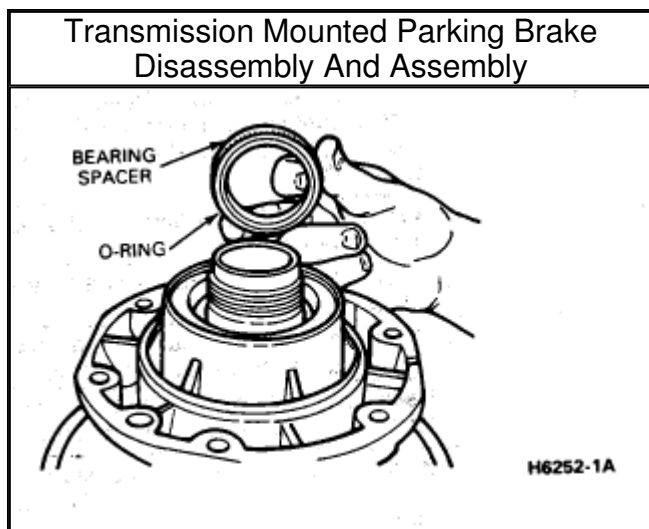

Zoom

Sized for Print

26. Install a new O-ring in the notch of the bearing spacer and install both parts onto the mainshaft until the space butts against the shoulder of the shaft.

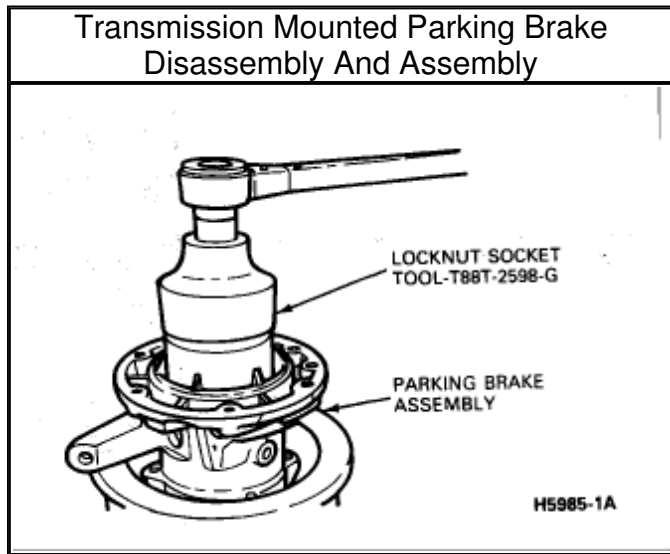

Zoom

Sized for Print

27. Install a new locknut on the shaft, and tighten to **288-292 Nm (212-216 ft-lb)** .
28. Upset the outer lip of the locknut into the slot in the shaft, using Tool T88T-2598-G, or equivalent.
29. Screw the vent into the case, and tighten it to **12-16 Nm (8-12 ft-lb)** .
30. Remove the parking brake assembly from the vise.
31. With the parking brake in the as installed position, fill the case with Ford Automatic Transmission Fluid (type H) XT-4-H, through the filler hole. Fill to the bottom of the filler hole, and install and tighten the fill plug to **59-63 Nm (43- 47 ft-lb)** .
32. Reinstall the parking brake assembly.