

\$3.95



Fisher Labs

# WORLD TREASURE NEWS



# 2009



IF IT'S UNDER THE EARTH... FISHER CAN FIND IT!



Volume 2 Number 1.1 - 2009

El Paso, Texas U.S.A.

[www.fisherlab.com](http://www.fisherlab.com) • 1-800-685-5050

PRO FILES

*Fisher Research Labs President's letter* .....3

*Choosing the Right Detector* .....4-6

*Detectorist gives thumbs up to the F75* .....6

*What to know about search coils* .....7

*The F4 is an outstanding metal detector.* .....8-9

*F-75 Peak Performance -by Tom Dankowski* .....10-12

*Fisher F-75, First Impression* .....13-15

*Ancient Celtic coin cache found in Netherlands* .....15

*Findings by Fisher Metal Detectors.* .....16-18

*Pictures from our friends in Norway* .....19

*Fisher F5 Review* .....20-21

*Discrimination mode "Sensitivity" and "Depth" in single-frequency VLF metal detectors* ..22

*PRO ACCESSORIES* .....23

PRO DETECTORS

*F75* .....24

*F70* .....24

*F5* .....25

*F4* .....25

*F2* .....26

*Gold Bug 2* .....26

*CZ-21* .....27

*1280-X* .....27

*1270-X* .....28

*CZ-3D* .....28

*Gemini-3* .....29

*Fisher Research Labs Platinum Dealer list* .....30-31

*Fisher History - Past to Current* .....Back Cover

Dear Treasure Hunting Enthusiast,

Welcome to the world of treasure hunting – brought to you like no other company can. Inside these pages, you'll read real stories about recent finds of long-buried treasures. Long-buried because our latest technological breakthroughs have just opened up a whole new world of lost treasures to you.

Whether you are considering your first venture into treasure hunting, or you're a seasoned pro looking for the latest technology, pay close attention because a lot has changed in just the last few years. Our rapid pace of technological innovation is turning old hunted-out sites into fertile hunting grounds and improving the odds of great finds for more people than ever.

While the virtues of practice and developed skill can never be underestimated, beginners and intermediate users can now get more than ever out of the hobby — more because more power, more features, and more new technologies are now available in every type of metal detector we manufacture.

Our team of engineers decided five years ago to break with convention and redefine the state of the art in metal detectors. You will find the result of that endeavor today in many forms, including the industry's best ergonomics, great user interfaces, and revolutionary advances in target separation capability.

Join the treasure hunt today! If you need advice or have any questions, please contact us direct or visit your local dealer. Share photos and stories of your finds with us; we would love to feature them in upcoming issues.

Happy Hunting,

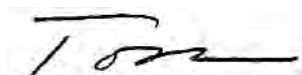

Tom Walsh  
President  
Fisher Research Labs



# Choosing the Right Detector

by **Don Hinks**

**Gettysburg Electronics**  
Gettysburg, Pennsylvania

For over 35 years I have been a supplier of quality metal detectors at my store in downtown historic Gettysburg. Since 1972, I have sold more than 8000 metal detectors to satisfied customers, one at a time, personally instructing them in the proper use of the detector that they have chosen. Since the late 1960's I have been an avid detectorist myself, using everything from the primitive heavy tube type instruments to the lightweight state-of-the-art computerized discriminating detectors of today.

For these last 35 years, I have strived to assist each customer in making the right decision when he or she chooses the best detector for their specific use and price range. With our large selection of new metal detectors on display, it can be bewildering to the first time user. To help the customer make the right choice, I first ask the customer what they plan to primarily use the detector for, and where will they be using it. No one specific model of a detector will excel in every situation.

Customers come into the store seeking detectors for many purposes. The most popular uses are for coin shooting, relics, jewelry (beach) and gold prospecting. Some other uses include scuba diving and cache hunting. Commercial and industrial uses occur as well, such as security (walk thru and hand held wands), surveyor (locating property stakes) and utility use for locating buried pipes or cables. Knowing the primary use of the detector determines what detector is best suited to fill their needs. There is no "one detector fits all."

In this article I will focus on coin shooting, relic and beach hunting, and prospecting. The ideal instrument for each of these types of detecting is different from the others as you will see.

## Coin Shooting

Coin hunting is a popular hobby all over the world. Coins have been in circulation since before the time of Christ. Coins, rings, jewelry, and other valuables have been lost daily for centuries. Unfortunately, these good targets are usually lying in the midst of large amounts of trash such as nails, scrap iron, aluminum foil, pull tabs, bottle caps, screw caps, pop tops, etc. Some detectorists don't mind recovering everything but the vast majority of coin shooters don't want to dig these unwanted targets. Most coinshooters desire to only recover coins, rings and jewelry, and other valuables. Some machines are better than others at achieving this. To avoid becoming discouraged by digging too much trash, the first recommendation I make is to select an instrument with good discrimination. This will narrow down the number of unwanted targets. Fortunately nearly all quality handheld hobby detectors produced today, have some form of variable discrimination that will eliminate certain undesirable objects.

Approximately 70% of the metal detectors that we stock have either a digital readout or a meter that will indicate likely coin targets, some even identifying the probable coin denomination. They also will identify probable pop top and tab targets.

This is known as "target identification" or "target ID"

Some discriminating detectors do not have a digital readout or meter to help identify targets. This type of machine usually has a linear type of discrimination adjustment that selectively eliminates targets as you increase the control.



Typically this linear setting first deletes iron, then foil, and so on up the scale of targets. The danger in increasing the level of discrimination to eliminate pull tabs is that at that level of discrimination many gold rings could be eliminated, and unless the instrument features dual discrimination or some type of notch discrimination, nickels and numerous other rings could be lost as

well. Unless pull tabs are excessive, I recommend digging them especially if there is a chance of there being gold rings or jewelry in the area.

In summary, for coin shooting I recommend an instrument with good discrimination that can effectively identify a large portion of worthless junk in the ground. Although some successful coin shooters use discriminating instruments without target ID, I recommend that if it is within your price range, or even a little higher than you had planned, purchase a unit with a digital readout or a meter. Consider at some point, buying a second, smaller coil, for use in hunting trashy areas. Smaller coils have better separation and work well in trashy areas.

**Recommended Coin Shooting Fisher Metal Detectors:** F75\*, F70\*, F5\*, F4\*, F2, CZ-3D\*.

**\*Highly Recommended**

## Relic Hunting

Being located in historic Gettysburg, PA, many of my customers are interested mainly in hunting Civil War relics. The use of metal detectors on National Park Service property is strictly prohibited anywhere in the United States, including the Gettysburg National Military Park. The use of detectors outside the NPS property is proper only with the permission of the property owner. The area around Gettysburg is dotted with many sites used as camping areas, hospital sites, battle, skirmish, and winter camp sites, not to mention all the roads traveling to and from these areas. With proper research and permission to hunt, these areas can be productive.

The needs of the relic hunter are different than the needs of the typical coin shooter. For the relic hunter, the three most important factors are depth, depth and more depth. The depth capability of a machine is always important but even more so if you wish to be a serious relic hunter. Revolutionary War, Civil War, and War of 1812 artifacts, as a general rule, are usually much deeper than modern coins and quite often found in rough terrain such as woods, overgrown

areas, croplands and pastures. Artifacts in plowed fields can be quite deep. Unexploded artillery shells can be several feet deep. Additionally, well known sites may have been detected for years and years, leaving only the very deepest targets remaining. If your machine can't detect a small target 10" deep, you may not recover anything.

While the coin shooter normally discriminates against all types of iron, most relic hunters desire iron objects. These can be cannonballs, artillery shells, bayonets, gun tools, weapons, as well as non ferrous bullets, buttons, buckles, spurs, etc. Discrimination and target identification are a plus in relic hunting but are not a necessity. Some of the finest and deepest relic hunting detectors do not have target ID. Because depth is important, you must have a machine that can cancel out ground mineralization with manual adjustments. Avoid machines that have factory preset ground balance because ground conditions can vary widely

detector they are very difficult to find.

Beach hunting can be done on the dry sand or out in the water where many rings are lost. Salt water beaches present special problems (mineralization) and you must determine if you will only shallow wade (with just the coil under water) or desire a totally submersible machine suitable for deep water wading or diving. All quality metal detectors have submersible search coils but not all control boxes are waterproof or suitable for the pressures of deep water diving.

In all types of beach hunting, the discrimination must be kept very low, eliminating only small iron (bobby pins and nails). Aluminum pull tabs and tin foil should not be discriminated or you will lose some gold and/or platinum rings as well. Some beach hunters operate with zero discrimination and dig everything. Use of a sand scoop will make target recovery fast and easy.

If you only plan on hunting dry sand and very shallow water a good coin shooting

---

***The depth capabilities of a detector are always one important factor whether a person is coinshooting, relic hunting, beach hunting, or prospecting.***

---

and you will need a machine that you can adjust to these various conditions.

In summary, serious relic hunters should consider purchasing the deepest instrument in their price range. Target identification is nice but not necessary. Get a machine with a manual ground balance adjustment. Use headphones to help hear deep targets and get the largest coil available to get maximum depth.

**Recommended Relic Hunting Fisher Metal Detectors:** F75\*, F70\*, F5\*, F4, F2, CZ-3D, 1270X\*.

**\*Highly Recommended**

## Beach Hunting

Beach hunters are typically looking for modern jewelry and coins, although some beaches can yield historic artifacts as well. Items dropped in the sand quickly disappear and without the aid of a metal

detector will work well if you keep the discrimination set low. If you wish to go out into deeper water you will need a totally submersible machine. Some machines have a single tone for all targets and some have variable tones for different targets. It's important to realize that most gold rings will read in the "middle" tones (above iron but below coins). An exception to this type of machine is the Pulse Induction (PI) which operates on totally different principles than most detectors, and these machines have little or no discrimination capabilities. All of these machines will work well in fresh water but salt water is a different story.

Wet salt makes the ground conductive. All metal detectors work well in the dry ocean sand but most single frequency detectors become erratic in the wet salt sand or in the surf. The detector sees the

sand as a large sheet of metal. In order to operate in those areas with most single frequency instruments, you must decrease the sensitivity of the instrument and it may still operate erratically. If you only occasionally visit the ocean and own an instrument that becomes erratic in wet salt sand, you can still operate perfectly in the dry sand area. If you live near the ocean, or get to the ocean frequently, you should consider investing in an instrument that will operate well in all conditions including wet salt sand. Multi frequency machines handle salt conditions well as do Pulse Induction machines. Metal detectors that operate well in salt water are generally higher priced than multipurpose detectors, but they are definitely worth the extra investment if you frequent the ocean.

In summary, keep your discrimination levels low, tonal ID gives you an advantage, and purchase a fully submersible machine if you wish to hunt deeper water. If you plan on hunting salt water areas often invest in a machine designed for those conditions.

**Recommended Beach Hunting Fisher Metal Detectors: F75, F70, F5\*, F4, F2, CZ-3D\*, CZ-21\*\*, 1280X\*.**

**\*Highly Recommended for salt water/wet sand**

**\*Completely Submersible**

## Prospecting

Fine gold and flakes are not detectable with a metal detector but nuggets (even some smaller than a BB) are detectable with the right type of metal detector. Nearly any machine will find a nugget if it is large enough, not too deep and not in highly mineralized soil. Every major manufacturer of metal detectors makes an instrument designed specifically for prospecting. If you are serious about detecting for gold you should consider purchasing one of these instruments. Units for prospecting normally operate at a higher frequency than most detectors because gold responds better to the higher frequencies. Gold is also commonly found in extremely mineralized ground called black sand. To detect gold effectively in these extreme conditions you need a machine that can balance out the high mineralization and maintain stability with a smooth threshold tone. Otherwise, small nuggets will not be detectable. In addition, special coil types are used on gold machines that enable the machine to cancel out the affects of the black sand. Pulse Induction machines also work well for gold hunting.

In summary, if you are really serious about prospecting with a metal detector you should consider purchasing an instrument designed specifically for that purpose. Your success rate will be much higher if you do. Extreme conditions



warrant a machine that can handle them.  
**Recommended Prospecting Fisher Metal Detectors: F75\*, F70, F5, Gold Bug 2\*.**  
**\*Highly Recommended**

I have discussed factors that you should consider as you choose a detector for your needs whether it be coin shooting, relic hunting, beach hunting, or prospecting. As noted before, there is no such thing as "one detector fits all." If you are now considering choosing a detector for one of these conditions consider the suggestions I have made and buy from a reputable dealer, preferably one within driving distance. This should be a dealer that not only sells detectors, but also uses them, and knows how to demonstrate proper use of each machine. Such a dealer will help you pick the best machine for your budget and your style of hunting.

## Thumbs up to the Fisher F75!



**Eddie M. Detectorist**

My first time out with the F75 was a very pleasant surprise. It was even more user friendly than I could have ever imagined.

I choose a spot I had given up on. After briefly reading the manual, learning how to ground balance with the coil pumping procedure, I decided

to keep the other settings as close to factory presets as possible. Right off I loved how easy to swing and well balanced the F75 was. All my signals were deep probably because the area had been hunted so

hard previously. A few hours into the hunt I had a nice repeatable signal, but very faint. After digging a deep hole in the sandy soil, I hit the clay bottom; putting the coil in the hole I got a less faint signal. Using my shovel, I carefully picked out a chunk of the



clay. Opening the clay I saw I was the proud new owner of a cuff Virginia staff button with at least 95% gilt left; this small button was approximately 18" deep.... wow! A few feet away, out pops a silver 3 cent piece around 10" deep. I found a few other deep period relics in my short first outing with a brand new detector.

All I have to say is that the F75 is truly a work of art!

Eddie M.

# What to know about searchcoils

by **Dave Johnson**

Chief Designer, Fisher Research Labs

**This essay pertains to induction balance searchcoils ("loops") of the types most commonly used on hand-held hobby-type metal detectors.**

## Searchcoil shape

Most searchcoils are round, but some are elliptical. This refers to the overall shape, not to the type of coil construction. In general, elliptical coils provide a broader sweep pattern over the ground, and narrower target response for better pinpointing. Round coils are easier to design and less expensive to manufacture, which is why they're the most common.

## Searchcoil type of construction

The words "concentric" and "DD" (or "double-D") refer to the type of internal coil construction.

Most searchcoils (whether round or elliptical) are of concentric construction. A concentric searchcoil has a large transmitter coil, and a smaller receiver coil in the center, usually in the same plane.

This coil arrangement is relatively easy to manufacture and its symmetry helps to minimize electrical drift due to time and temperature. It also provides good discrimination on shallow targets.

Some searchcoils (whether round or elliptical) are of DD construction. Double-D's comprise two overlapping D-shaped coils of approximately the same size, one being the transmitter and the other the receiver. The advantages of the DD are greater depth in mineralized soil, a broad sweep pattern, and narrower target response. Its primary disadvantages from a user's point of view are multiple responses on shallow targets and poor discrimination of flat iron objects. Designing and manufacturing them is more difficult because their lack of radial symmetry makes them prone to drift which the design and the manufacturing process must minimize. Manufacturing cost is higher because the coils cannot be wound on high-speed winding equipment.

## Searchcoil size

Most standard searchcoils are approximately 8 inches (20 cm)

in diameter if round, or approximately 10 inches (25 cm) in length if elliptical. Larger searchcoils allow covering more area with each sweep, and offer a slight increase in depth on medium and



*Fisher Research Labs group of engineers, Left to Right: Mark Krieger, John Gardiner, David Johnson, Jorge Anton Saad*

large size targets. Unfortunately they are heavier, more difficult to pinpoint with, tend to lose small targets, and provide poor target separation. Small searchcoils provide superior target separation (important in trashy areas) and the ability to detect smaller targets (important in gold prospecting). Of course they don't cover as much ground as a standard size coil. However (and this may surprise you) small searchcoils usually have nearly as much depth capability as standard size searchcoils.

## What's on the market and why

The least expensive metal detectors usually come equipped with a round concentric searchcoil. The more expensive recent models often come equipped with an elliptical and/or DD searchcoil. Older models, even expensive ones, frequently don't have a DD searchcoil available because DD's fell out of favor during the 1980's and 1990's as the knowledge of how to make DD's did not advance fast enough to keep up with the demands of higher performance circuit designs. Nowadays there seems to be a trend toward DD's as manufacturers have gained more confidence in their ability to design and make them.

## What users tend to prefer

Double-D's are usually preferred for relic hunting and gold prospecting. Concentrics are usually preferred when searching for modern coins in an area where there is also iron and aluminum trash.



# The F4 is an outstanding metal detector

*with enough power to satisfy even the most discerning hobbyist*

by **Mark Ellington**

I've always heard "The older you get, the faster time passes." Now that I'm in my mid 40's I've found that statement to be all too true. However, there are exceptions to this rule.... Christmas, payday and waiting for a metal detector to arrive in the mail! I'm the first to admit, I become very "kid like" when I have a new machine on the way to my house. My wife is very "understanding" of this affliction of mine, only succumbing to the occasional "eye roll" when I constantly babble on about treasure hunting, old sites, coins and metal detectors.

The subject of this particular dose of excitement was the new Fisher F4. Fisher Research Laboratories, the oldest hobby metal detecting manufacturers in the world, was purchased by First Texas Products of El Paso Texas. First Texas also owns the Bounty Hunter and Teknetics brands. At first, a lot of folks in the metal detecting hobby didn't know what to make of the Fisher purchase... would First Texas continue the long tradition of high performance/high quality metal detectors? Would the "new" Fisher be introducing new exciting models? Luckily for us, the answer to both these questions is a resounding "YES!"

**Assembly and First Impressions** - My new F4 was shipped double boxed, which is a nice touch in my book. After unpacking it, I was immediately impressed by the high quality feel of the gold anodized rods and the heavy duty plastic arm cup. Assembly was a breeze, with all the poles locking securely in place. I noticed that the pole length adjustment has enough range to handle the needs of most detectorists. The fit, finish and "feel" of the F4 impress me as very high quality.

Like most folks, my first act after assembly of a brand sparkling new metal

detector is to take a few "test swings" across the floor. I'm blown away by the light weight and balance of this machine! I'm also very impressed by the lack of any movement or flex in the shaft, even during "vigorous" swinging... nice and tight! I finally decided it's time to get down to business. I notice there are no batteries in the shipping box, so I assume none are included. Wrong assumption! I open the battery compartment and find two 9 volt alkaline cells installed "backwards" for shipping purposes. I carefully removed the batteries... (Be careful, they are pretty tight!) and installed them. Finally! The moment of truth!

**Display and Controls** - A light press with my right thumb brings the F4 to life. The F4 makes use of membrane type buttons that offer a light "click" for feedback. The LCD display is clear and sharp with a centrally located conductivity ID number. Along the top is an arc of various common targets, ranging from iron to \$1. An LCD "arrow" points to the detected target, making for quick and easy identification. To the left of the conductivity ID is a "on the fly" depth gauge that displays the depth of the currently detected item in 2" increments. On the right is a battery meter, constantly monitoring the power level of the nine volt cells. The faceplate itself looks great. The red, gold and black color scheme is very "pleasing to the eye" and all the buttons are logically placed and clearly marked.

The face of the detector has nine touch pads and one ground balance knob. Available controls are: On/Off, Sensitivity up and down, All metal auto tune, Pinpoint, Disc, Notch and Discrimination/Threshold up and down. The "Disc" button toggles the F4 between an "all metal discrimination mode" and a "discrimination mode". All metal discrimination allows all targets to be heard

and identified using both the visual ID indicators and the 4 tone audio ID. The "discrimination mode" activates the discrimination circuits, allowing you to eliminate any targets you wish all the way through zinc penny. My experience with the F4 is that the "all metal discrimination" mode provided outstanding detection depth, while "discrimination" mode did a great job of getting rid of unwanted trash items.

**Test Garden and "Real Life" Use** - I grabbed a few test targets and gave them a swing in front of the DD coil. The 4 tone audio from the internal speaker is very clear and distinct. The corresponding ID numbers, and target icons seem to be dead "on the money" (pun intended). The F4 seems to be marketed as a "mid range" metal detector, but the air testing I did was comparable to many detectors I've had that cost much more.

Every time I get a new detector, my first destination is my "test garden". I've had it planted for several years with a large variety of targets buried at different depths. The F4 with the double-D coil was able to correctly identify closely located targets with a precision that nearly rivals my F-75. Very impressive! Depth is much better than I expected from a mid-level machine, and I was able to run it at maximum sensitivity in my yard without any false signals. Pinpointing was a breeze with the toggle on/off style pinpoint button. Entering the pinpoint mode changes the central ID numbers into an "inches of depth" reading. The numbering combined with the great VCO audio made it very easy to size up your targets and avoid large trash items.

My next stop was a local school yard. In my opinion, school yards are the best place to learn a new metal detector. Targets are plentiful, and digging is easy. The F4 felt "custom made" for this type of



hunting. The 11" DD coil cuts a wide swath allowing you to cover ground quickly without fear of missing targets. One of the beautiful things about a Double-D type coil is the great heel to toe ground coverage. I was immediately rewarded for my detecting efforts with coin after coin. The high tone audio "sang out" to me on copper pennies, dimes and quarters. Another cool thing I discovered is that the visual ID number stays locked on the last target detected, allowing you to hunt by sound, then refer to the meter afterwards.

The F4 has a very unique notching system that allows you to either choose the item you want to reject manually, or by waving a troublesome trash item in front of the coil, then hitting the "notch" button. Both methods work great and completely discriminated out the unwanted target. Another way to use "notch" is to crank up the discrimination as high as you want to go (all the way through "zinc"), then "notch" back in a desired item. This is what I opted to do for my school yard hunt. Discrimination was maxed out through zinc, and nickels "notched" back in.

This made for a VERY productive coin hunt! Nickels came in the ID dead on the "30" mark, while still rejecting most pulltabs and pencil eraser bands. For the clad coin hunter on a limited time frame, this mode of hunting is outstanding. Your "coins per minute" count will

undoubtedly skyrocket with the sheer volume of ground you can cover, while avoiding the trash items. I ended the school hunt with a nail apron FULL of coins of all denominations including a couple of Susan B. Anthony dollars and a Sacajawea dollar.

**Conclusion** - I've gained more and more respect for the F4 during the 40 hours I've logged on it so far. In my opinion, this detector is a great multi-purpose machine that would be an excellent addition regardless of whether you're a "seasoned pro" or just getting started in the hobby. Don't think that the F4 is just a "Clad Killer". Although it does excel at that type of hunting, I've recovered several wheat cents and a few pieces of silver since I've been using it. The F4 is incredibly "quiet" until you hit a target, and the audio feedback with 4 distinct tones is very good. All-metal depth is incredible and quite easy to ground balance.

Durability doesn't seem to be an issue. I hate to admit it, but while hunting, I stopped to adjust my headphones, leaning the F4 against my side. Before I could catch it, it fell straight to the ground with a couple of bounces on impact. I just knew I had killed it for sure, but it never missed a beat! This tough little detector was no worse for the wear. The plastics Fisher has chosen for the unit seems to be very, very resilient.

Coil availability is a huge plus! The F4 comes shipped with the 11" Double-D elliptical coil and available for purchase at very reasonable prices are 4", 8" and a 10". An incredible selection that will cover most hunting needs!

My personal opinion is that the F4 is an outstanding metal detector. It is very much a "turn-on-and-go" type detector, but with enough power to satisfy even the most discerning hobbyist. Between the F-75 and the F4, Fisher has proven they are serious about the high performance hobby market.



## F-75 Peak Performance

### Disc 6 & mandatory monotone relic hunting justification

#### Intelligent Hunting Advice

by Thomas J. Dankowski

When the F-75 is placed on a Disc setting of 6 and monotone, this set-up configuration allows (under MOST circumstances) the best iron see-thru ability in locating non-ferrous targets in areas that are loaded with ferrous (usually nails) targets. The older the site, the more nails will be present and subsequently, the more good targets will be masked. Most detectors will shutdown under these scenarios. The F-75 (and the T-2) are the only detectors currently available on the market that begins to tackle this type of extremely common scenario with some unmasking success.

With F-75 Disc on 6 and monotone audio, the moment you invoke a different tone option, say 2-tone, 3-tone, 4-tone, etc., the audio portion of the Disc, even though Disc is set on 6, will instantly become a Disc setting of 15. What does this mean? Any target that is between a Disc level of 6 thru 15 will now audibly report as a low tone (iron tone). BIG PROBLEM for a multiplicity of reasonings. Any target that is ABOVE a 15 VDI reading MIGHT report a higher tone depending on what tone option is invoked. Most folks do not dig iron and most folks WILL miss masked non-ferrous targets when multitones are selected. To explain, I will use an example that happened to me. I recently recovered a badly masked Barber dime. When I first detected this severely handicapped dime, the F-75 was in monotone, Disc 6, PF and Sens on 99. In monotone the dime AUDIBLY sounded good. I was going to dig this target but the VDI was terrible. It would/could NOT lock on to anything close to resembling a highly conductive piece of silver. I then invoked 2-tone leaving ALL other settings alone. Now the dime was constantly audibly reporting as low-tone (iron-tone) even as I rotated my body around target. The VDI was jumping all over the board, but mostly in the iron ID range. I made the decision to NOT recover the target, primarily due to low iron-tone and walked away. Several

hours later, I decided to go back and recover this target (and MANY other similar responding targets) with F-75 back in monotone. The results were one 2" nail, two 1/2" long nails, and one 1893 'O' Barber dime. Yep, MOSTLY iron, but certainly not ALL iron. The 2-tone mode did not lie. Justification = the composite of the 4 targets (3 nails & one dime) were higher in conductivity than any one of the nails individually but TOTAL conductive composite was HIGHER than any nail (or combination of nails) would have cumulatively registered. Because I (and the detector) knew that the detected target (suspected co-locate/composite of multiple targets under coil) were higher than the conductivity of most nails yet STILL ID'd in the Fe/iron range, this target was needing recovery. Good thing! Selecting any other tone option and the detector would audibly report the composite as low-tone/iron-tone. Yes, the F-75 will still unmask more nonferrous targets than other detectors if 2- tone or multiple tones are selected. However, a substantially greater level of unmasking performance can be ascertained when the unit is placed in monotone. The same results can be achieved on the the T-2 with a Disc setting of 21. Having the ability to adjust how MUCH iron you choose to discriminate is a major attribute. Small iron items such as nails, will Disc out at a fairly low iron Disc range. This is approximately 10% of the F-75's capabilities. In addendum:

#1 On both the T-2 & F-75, running a higher Sens gain in the trash (especially iron) presents a MUCH enhanced resolution on non-ferrous targets amongst iron. This is a paradoxical contradiction; what is, but should NEVER be. Next time you find a non-ferrous target amongst high iron trash concentration (with high Sens settings), drop the Sens and see what happens. The non-ferrous target audio resolution will decrease and possibly even disappear completely. It depends how badly masked the non-Fe target is. The more masking, the HIGHER the Sens needs to be on the T-2/F-75 (this is not a typo)!

#2 The mandatory monotone instruction is primarily for iron nail pits. Long description: If a non-ferrous target is co-located in very close proximity to iron/multi-iron scenario then as you rotate your body around the composite target the audio will be bouncing between all of the different tones (same with VDI) and each tone being exceptionally short in duration. You may even encounter a multi-tone audible reporting in ONE sweep of the coil! Surely enough to confuse most detectorists into a NON-recovery decision as the target is audibly confusing and is not a clean or solid repeatable sounding target (most masked targets are not clean audio targets). Each of the multi-tones reporting will be audibly shorter in duration. A kind of a ratty sounding, bouncing signal. NOW, when monotone is selected/invoked, this SAME composite target(s) will audibly report a LONGER duration SINGLE-tone audible presentation (instead of several shorter-in-length different tones in one sweep of the coil) that will less-likely confuse the operator and authorize the operator to make a much better profiling of the composite target audio signature, with the end resultant being a more intelligible target-recovery decision from less audible fatigue. Tech Terms; A better signal-to-hull emitter correlation. I'd rather hear ONE longer monotone vs. several shorter multi-tones in rapid succession (in a single coil sweep). NOW IMAGINE sweeping the coil in a iron nail pit with 2 or 3 or especially 4 tones selected. A hillbilly jug band!!! Try and make non-fatigued intelligent audio decisions under this common scenario! The VDI is extremely jumpy in iron pits AND SO WOULD BE THE MULTI-TONES!!! At least in monotone, as the VDI is presenting extreme variances, the one monotone will be CONSTANT and STABLE, even as the conductivity of the multi-target scenario varies dramatically, even with only one sweep of the coil.

**#3** On CZ-3D in the enhanced mode, nearly ALL old and new coins will report as hi-tone. On the F-75 and T-2 you MUST invoke 4-tone which will then cause the OLD coins to audibly report in the 3rd highest tone region (vs. mid-tone) and the new coins will remain in THE highest tone. If you select 3-tone on T-2/F-75 only the NEW coins will report as high-tone and SOME of the older coins might report as high tone. Most of the older coins would then audibly report as mid-tone (just like the aluminum soda tabs).

**#4** If you run Disc on 0-4 on the F-75, all nails will report as good targets in monotone. With F-75 Disc on 6... MOST (not all) nails will report as a snap-crackle-pop or tick-click (not a solid audio) which, in turn can be ignored. Axe heads, hammers, gun barrels and other large iron targets will give a good audio with Disc on 6 on the F-75 but MOST fields we hunt are not loaded with axe heads, gun barrels and hammers.

**#5** The F-75/T-2 have a tendency to up-average non-ferrous target ID numbers when near disintegrated iron or bad minerals. VERY common occurrence. It is partial silent masking coupled with conductive target response. I have several documented experiences exactly relating to this. Let's say that you detect a slightly masked silver dime. Normally without being masked, it would VDI at 71 but masked it may now VDI at 89, a somewhat up-averaging VDI common resultant. In both cases, the detector reports hi-tone. No problems yet. A slightly corroded buffalo nickel will VDI at 28 in open air and audibly report as a hi-tone. With this same nickel in the dirt, in a natural setting and partially masked, IT TOO will up-average just like the silver dime, to, say a VDI of 47. Hmmmmmm, now the nickel looks like a soda tab to the detector and the unit will now report the slightly masked nickel as a mid-tone. All of this holds true for other medium conductivity items such as relics & gold jewelry.

If you are recovering Mercury dimes at say the 11" depth range, you may want to ALSO recover the 11" depth

range midtones as many of these will be the corresponding era Buffalo nickels. The T-2 & F-75 electronic design architect is notorious for up-averaging nonferrous targets in the presence of iron & iron oxides. Not a problem, considering other single freq units would remain completely silent. ALL detectors have a difficult time ID'ing nickels. CZ's do the best ID job, but are not immune to EASILY mis-ID'ing nickels.

**#6** All-Metal mode is the deepest mode, HOWEVER, coin-sized objects will still ID to depths of only 12" or so. The depth at which a target will properly ID in the ID mode is the same depth it will properly ID in the AM mode (F-75 & T-2). Yes, targets will audibly report to greater depths in the AM mode but the VDI screen will remain blank on the deeper targets. Now, that being said, IF you are an extremely seasoned hunter you can take advantage of these greater (no VDI) deeper depths. If you can audibly profile deep/weak targets, you are in for some serious enjoyment. Can you tell the difference between a small target that is shallow, such as a lead .22 Short 29Gr rimfire projectile at 4" deep vs. a U.S. nickel at 12" depth? These are both nonferrous targets. And can you tell the difference between a 2-Penny nail at 7" vs. a Wheat penny at 12"? This latter example is the MOST common and MOST important test for the astute Detectorist as it poses the greatest challenge with the most significant rewarding result. Of note: Dinosaurs can be miles beneath the Earth's surface; Egyptian sunken cities are dozens of feet Deep; thusly the 100 year-old coins we wish to find are a foot or two deep. NOW, that being said, if you are in a nail infested area, and you do NOT audibly fatigue easily, IF, IF, IF, you can handle a lot of noise and the detector can handle (not EMI plagued) a Disc setting of 0 and a Sens setting of 99, then hunt in 2, 3, 4 tones (your choice) for the deepies. YES, the detector will mask some targets in this audio selection configuration (ie 2, 3, 4 tones are selected) because any heavily masked target that VDI ID's as a 15 or below will present a iron audio response (example above), BUT, the trade-off is: the F-75 will go deeper just

by virtue of the Disc setting being 4 or below (especially 0). Soooooooo, I am saying by this set-up configuration =MORE MASKING, BUT GREATER DEPTH. Hmmmmmmm, trade-off. Which one does better? Disc 6 & monotone???? or Disc 0 and multitone???? The answer is: They BOTH do!!! I am saying; HUNT the area in Disc 6 & monotone... and perform all of the unmasking that you can. THEN hunt in Disc 0 and a tone-option of your choice... going for all the deepies. NO, you can not have both at the same time. In theory, in an ideal world, targets are spaced far enough apart so as to be single, solo targets, not tilted, not near hot rocks, not near iron, no dirt mineralization etc. This would allow the detector to ID targets with the greatest accuracy. HOWEVER, this is not reality, not the real world. Fact of the matter is, nearly all targets are somewhat/somehow handicapped. First, as a good target (say a coin) is moved closer to any other metallic object, a multiplicity of problems are introduced to the detector. Now add dirt mineralization, tilt the coin, add a hot rock or two, etc., WELCOME TO THE REAL WORLD! This is genuinely what we contend with as detectorists and detector engineers. How do you correct and compensate for infinite unpredictable variables?! Secondly, what may be categorized and classified as "these two targets are too close to each other" to Brand A detector & coil assembly may present different results to Brand 'B' detector & coil assembly. The extremely enhanced adjacent target separation characteristics afforded by a Elliptical Double D Coil vs. a Concentric Coil presents just exactly such a scenario. A coin and a pull-tab, both at a 6" depth and adjacently separated by 6", poses a severe problem to a 10.5" Concentric Coil but does not even approach "problem" status to a 11" elliptical DD Coil.

**When absolute maximum overdriven performance is desired:**

- 1) Starting point = Factory Preset and Ground Balance.
- 2) Hold coil parallel to ground.... and at a height (approx) 8" above the ground.

Do not tilt the coil upward. Increase Sens to 99 and verify detector is audibly stable. This is the FIRST step. (If the detector becomes chattery/unstable, try changing the detector's selectable frequencies (F1 - F7) and see if this helps mitigate the instability. If not, then lower the Sensitivity to the point in which the instability just barely disappears. Hunt with these settings and do not proceed any further with the proceeding steps).

3) Next, IF no EMI is encountered with 99 Sens, THEN you may start to bring Disc down. Start with Disc 6.

4) IF the detector is still EMI stable, see what happens to EMI stability by lowering Disc BELOW 5. 5 is not the magic number but 4 is. Going to a Disc setting of 4 is where sensitivity receives yet another boost (and USUALLY when you are at a Disc of 4 and ESPECIALLY lower, is where multitone option is virtually required). Set Disc on 4 and verify detector remains audibly stable.

5) Now, drop Disc to 3 then 2 then 1 then ultimately 0, and verify audio stability is still retained.

6) Now select JE mode and verify detector remains audibly quiet. IF during any of these steps, the detector becomes audibly chattery, you have electrical interference (EMI) and must back-up in procedure until you find electrical stability, and these are the settings you should hunt with.

7) Start sweeping the coil with the coil remaining 8" above the ground and verify detector remains audibly stable.

8) Start lowering the coil closer to the ground while continuing to sweep and verify detector remains audibly stable. If you manage to get the coil all the way down onto the ground while sweeping and the detector is audibly stable, you are home-free, and have the most powerful relic detector currently on the market. Remember, many relics are very low conductors (in the foil range). IF, while lowering the coil to the ground as you are sweeping, and the detector THEN becomes audibly unstable, you have ground interference, most probably from high volumes of tiny flakes of rust/iron (a VERY common dirt occurrence) which then you must back out of the JE mode.

9) It is your choice for tone options. I have YET to be able to handle a nail infested site with the detector in monotone and a Disc setting of 0. This means that you hear absolutely everything. It is not so much that a Design Engineer would overengineer a detector to be audibly unintelligible; it's more a sensitivity function of a gold prospecting capable unit coupled with a extremely fast microprocessor/clockspeed and very tight electromagnetic footprint emanating from the coil. Little flecks of iron will cause this particular detector (F-75 & T-2) to sound electromagnetically unstable. On a recent hunt, I (as usual) was overdriving the F-75 and in one area it became electrically unstable, or so I thought. Coil in the air and unit was stable. Coil on the ground and not moving and unit was mostly stable. Sweeping coil and EMI interference ensued. Hmmm. Let's dig some of these so-called chatters. Resultant: About every 2" or 3" I was finding #2 lead shot from a shotgun at a depth of approx 1.5". I quit recovering them once I had about a dozen in my hand. The small spot of land that I recovered/removed these small BB's suddenly had no electrical chatter in this one localized location of coil-sweep.

Exterior of this sans spot the electrical chatter resumed. I knew I was overdriving the F-75 and decided to drop the Sens to a setting of 70 and the perceived electrical chatter (the BB-shot) as coil was being swept, suddenly vanished. I had desensitized the detector enough to no longer detect these small targets and the unit became stable again. Masking was still taking place though. It hurts me to drop Sens to lower levels, however, I could ascertain a more stable/intelligible unit and could then somewhat hunt. Targets beneath these BB's are going to be partially or completely masked.

Another known engineering fact is that a single freq unit has the ability to handle iron better than multi-freq units. Both types of units are still blinded (masked & silent masked) by iron, but the single freq units can ID iron with better accuracy, less falsing, and a hair-splitting Disc setting is more ascertainable with a single freq unit. Something worth mentioning is in

reference to the CZ (and nearly all other units). When the coil is passed over a target (or multi-target co-locate scenario), the reporting circuitry will remain silent. When peak signal strength is ascertained, the detector reporting circuitry will STILL remain silent. When the electronics see the received signal strength start to decay (decrease), then, and only then, will the detector take a best-guess and report a target and ID. Keep in mind, if multiple targets are under the coil at the same time, these types of detectors will wait until the largest COMPOSITE signal strength (only one) is achieved. And now the different animals: the T-2 and F-75. Their electronics and audio will fire on ANY target and take multiple snap-shots and report each one. Hence, the F-75 and T-2 will audibly sound very noisy. Said differently, let's say the dirt is sans except for one single coin target at several inches deep. At a normal sweep-rate, the F-75 and T-2 will fire many many many times (dictated by microprocessor clock speed) on the coin and report each firing individually BUT what do your human ears hear/register? It just simply sounds like one continuous beep to you. It's not! Now pass your coil over many extremely close (and very small) co-located targets with F-75/T-2 and see if your brain can process at the same speed of the F-75/T-2. You will also notice the VDI jumping radically. Do you think the VDI is incorrect!!!!?? These steroidic detectors (unfortunately) are mentally fatiguing, not because of the detector but due to our ears clock-speed. The CZ's are a MUCH smoother, MUCH better sounding unit and SO much easier to detect/hunt with. BUT, they can be quite blind (easily masked) and can close doors where the F-75/T-2 can re-open hunted-out sites with tremendous success, especially with a slower coil sweep-speed in hi trash areas. Which is food for thought.

Happy Intelligent Hunting!  
Thomas J. Dankowski

For more Intelligent Hunting advise go to:  
[www.fisherlab.com/hobby/fisher\\_intelligence6th.html](http://www.fisherlab.com/hobby/fisher_intelligence6th.html)

# Fisher F-75: First Impression

by **Gene Scullion**  
**Badger Metal Detectors**  
**Madison, Wisconsin**

It's not often a new machine gets my attention very quickly. I usually watch and wait for the reports, read the forums, listen to the feedback, and talk to the new users. I am comfortable with the small arsenal of machines I currently have and I was in no hurry to purchase a new F-75, but sometimes fate has a funny way of changing ones plans.

I was invited to hunt with a friend at a military site, and I took my normal relic machine while Mike Scott brought his F-75. I was looking forward to being able to compare targets with this new machine, and see how it stacked up to my machine. As luck would have it we were not always within earshot of each other, but both machines easily registered the targets we did compare. Nothing significant was determined and certainly nothing indicated to me that this new machine was any deeper than what I was using.

This particular site was covered with a lot of forest clutter. The ground was covered with broken branches and tree limbs and other debris. So much so that we would rake an area clean and then detect it. I had cleaned off a new area about 20 foot square, and was the first person to really hunt this particular plot of ground carefully. The targets were numerous and I was very excited to be doing so well. Mike was re-hunting areas already covered previously, preferring to hunt the areas that had already been cleaned of debris. I finished my area after several hours and began to move to adjoining spots when Mike announced he had to leave for several hours, to attend a previous commitment. We both had thought we would call it a day at this point but because of the success we were both having neither of us really wanted to leave. He wanted to come back after his commitment and I certainly wanted to continue hunting so it was an easy decision.

He said he would leave his F-75 for me to use, if I wanted to try it. I was somewhat apprehensive, yet mysteriously excited to be able finally try this new machine and I certainly didn't want to leave this awesome site! It didn't take much convincing to get me to try the F-75.

My first thought was that I really would not know what to listen for or how to operate the unit effectively. I certainly didn't want to handicap myself at such a great site but Mike had everything set on the F-75, all I had to do was hunt. After a quick lesson Mike left and I was on my own. I wandered around, trying to get used to the signals I was hearing, and I must admit I was a little frustrated at first. But within 15 minutes I could tell good from bad targets and after digging a few good buttons I was gaining confidence fast. It was then I realized that what I should be doing is hunting the exact 20-foot area that I had just cleaned out with my other machine. What better way to see if this machine was any better than my detector? I had a cockiness of attitude, believing I might find a few targets my machine might have missed, but I was sure I would not be too surprised. Well, slap me and call me "Shirley"! I spent the next two hours digging target after target in the area I thought I had worked pretty good. I was shocked, surprised, and a bit stunned. How could I have missed so many targets? None were extremely deep, that I recall, but nonetheless, I found half again as much as I had on the first pass with my other machine. I am not a sloppy hunter, I carefully grid my areas and work them carefully, then turn at 90 degrees and work the area again crossing over my previous grid a second time. I may have missed a few targets during my initial sweep using my detector, but certainly not that many. I could only come to one possible conclusion: the F-75 smoked my other machine. Try as I might, I could not justify things any other way.

After several hours, Mike returned and I

relayed my experience to him. He just smiled, having experienced the same thing himself when he first started using the F-75. I reluctantly handed the F-75 back to him, and we both continued to hunt this site for several more hours. We both continued to dig targets, but I couldn't help but wonder what targets I was missing. I am certainly not going to cast aside my favorite machines because of this two-hour comparison, but it convinced me that I need to investigate this machine more. As a dealer, I need to learn this new machine so I can better service my customers. As a user I need to learn this machine to see how well it does on the sites I normally hunt, under the conditions I normally hunt in. Only then will I decide if it's better than what I am currently using.

When I finally received my F-75 I opened the box and was a bit surprised by the "Read This First" instruction page taped to the bag that contained the control housing. Wow, Fisher is actually warning its users that the machine is very sensitive and explains the basics right there on the very first thing you see when you open the box. I then set the manual aside, and quickly assembled my new machine. After all, I am a veteran detectorist; I should be able to figure this machine out without having to read a manual, right? OK, I was a bit mistaken on that part but the actual operation of the machine IS very easy, with only two controls needed to make every adjustment possible, and an on/off/volume control.

I must admit, I was impressed with how easy the F-75 was to adjust and move around the menu's. It is very straightforward and easy to understand and adjust. What is not so evident is what some of the screen abbreviations stand for, so eventually had to open the manual to figure what "bc" and "pf" modes stood for. That said, I realized there was more here than meets the eye, so I sat



down and read the entire manual.

I had a general idea of how this machine worked because of my early experience with Mike's machine, and I spent several weeks reading "Fisher" forum site posts and contacting several other people I knew that had already traded their old machines (the very one that I have been using) for this new F-75. I gleaned a few secrets and suggestions, and re-read the manual again. All of this occurred during my early hours of using the F-75. I instinctively thought that I should crank the sensitivity, you know, to see what the machine could do (in spite of what the manual instructs you to do), but I quickly learned that is not the approach you can use with this machine. Like other really sensitive machines, one must temper your belief that "more is better" and really follow the instructions in the manual. You really need to run the sensitivity as high as you can, but still keep the machine stable and relatively quiet. That may mean turning the sensitivity down but on this machine even "low" sensitivity can be much greater than what you are used to seeing on other machines. Trust me on this, pay no attention to what number setting you have it on, run it where its smooth and quiet, at least until you learn the machine and have a few hours under your belt. At some sites you can run it higher than at others, it depends on the conditions and interference encountered. Let the machine dictate where you set the controls so it runs smooth and quiet.

My primary passion is relic hunting so my observations will revolve around that aspect of the hobby. From what I can tell this machine really is a jack of all trades, good for relics, coins, beach hunting, gold hunting, it does it all. Reports posted on some of the metal detecting forums point this out as well.

I will save all the boring details about the sites I visited, but they are sites that I have been hunting for years. Some I consider "picked clean" and rarely find targets any more. Others still give occasional goodies, but its getting harder and harder to make finds. I have several ghost town sites that now consist of crop and grazing lands, a stage stop site, and of course one military

site. Each site I took it to I was able to detect some targets. At some sites I was pleasantly surprised, and at one site I found virtually nothing.

At one ghost town site, I found a toe cleat, spoon parts, several musket balls and a small button, and a number of pieces of lead splash. I was mildly impressed; this was the most targets I had pulled from this site in years. I also found a nice 1838 seated half dime! Not sure how I missed that before but the F-75 had pulled more for me in 5 hours than I had found in my last 5 trips to this site. It was a good day, and I was happy.

My next spot was a stage stop, again a site that I alone have hammered to death. This site yielded coins back to 1797 in the past but on my last three trips here I dug almost nothing. This really was a favorite spot of mine but I was slowly accepting the fact that I had hunted it out. Two trips here with the F-75 gave up some very small targets, but nothing deep.

This past weekend I was again in the company of my friend Mike, and he and I hit the same site I wrote about earlier. Excitement was high as we walked to the site, discussing what our best plan of action would be. We both figured that we had done a good job the last time and that we would probably have to move to a different location because last time we spent the whole day digging in a 40 square yard area. We were both there a good 6-7 hours and had roamed all over the area numerous times. If there were any targets left, it sure wouldn't be very many. Mike began hunting in the same spot we already worked, and I ventured a bit further away. Mike was digging targets while I was not, so after an hour I too moved back to the

"hot spot".

Again I will save you all the details but we ended up spending the entire day in the same general area, slowly working around it, listening for the faint singles. I tried various settings, but usually ended up with hunting in JE mode, sensitivity all the way up to 95, two tone mode, with disc turn all the way down to 4. With this setup, I was able to hear all of the iron targets, but more importantly also hear the high "zip" of good targets mixed in with the iron. By keeping the disc low it seemed like the masking affect of iron was minimized, or in some cases gone all together. It was not uncommon to dig good targets out a hole with multiple iron targets.

We were both surprised by the fact that we were still finding targets in the exact same area that we hammered weeks before. Granted, they were deeper, smaller, and weaker signals, but we were still digging a lot of targets. I should also mention that this site contains a LOT OF IRON! We spent 9 more hours hunting the exact same area, but then, there was no reason to leave since we kept digging good targets. I ended up with 28 swan shot, 13 pieces of misc. lead splash, 8 large musket balls, part of a cuff link, and 18 buttons. Oh yes, and one coin, but I will come back to that in a bit. The buttons consisted of 5 large pewter 4-hole buttons, two one-piece flat buttons, a kepi button, two two-piece brass eagle cuffs (one Artillery and one Dragoon), four one-piece eagle cuffs in pewter and one one-piece eagle coat button, and four pewter general service (US) buttons! The "US" is visible on all of the general service buttons and the dragoon was my very first! Mike's take was a little bit better than mine. Boy, what a day!

There were two distinct finds that I remember, both were US pewter buttons, one I was able to measure the exact distance. It was the full length of my digger



which measures 1 1/4". The second button was at about the same level but what makes both of these two finds interesting is that I pulled a one inch chunk of rusted iron out of the hole, before reaching them at a deeper location.

One other find was memorable: The 1827 bust dime! This too was a very weak signal, a high "zip" buried in the grunt-grunt of iron targets. It was inconsistent and faint, and I actually began to walk away, but only got a few feet away before turning back to find out what it was. Boy am I glad I did! It was about 10" deep. Mike and I whooped it up, high-fived, took some pictures, and then got back to business.

I now have many hours on the F-75 and

I must say, this machine is very easy to use, right out of the box. It is sensitive, no question about it and a bit different than what the hobby is used to, but easy to master in a short period of time. Because it's sensitive, some may find it intimidating, but trust me when I tell you with proper instruction and some tips from your dealer, you too can experience the power of this very versatile machine. I am of the belief at this point, that Dave Johnson and his team of engineers sat down one day and brainstormed the following concept: what would the perfect coin/relic/gold machine be like? What features would it have? What features would the users want? They came up with a blueprint, then decided on which

of those ideas they could actually achieve, and the result is the F-75. In principle at least, it seems like the perfect, all around machine. I am by no means an expert, but I really like what I see and I think I will be studying this machine for awhile. So the best advice I can give anyone trying this machine is to take your time, be patient, and give it some time before you decide. This machine may not be for everyone but those that take the time to learn it will do very well.

## Ancient Celtic coin cache found in Netherlands

By Toby Sterling

Associated Press Writer

Thu Nov 13, 4:23 pm ET

<http://news.yahoo.com>

AMSTERDAM, Netherlands — A hobbyist with a metal detector struck both gold and silver when he uncovered an important cache of ancient Celtic coins in a cornfield in the southern Dutch city of Maastricht.

"It's exciting, like a little boy's dream," Paul Curfs, 47, said Thursday after the spectacular find was made public.

Archaeologists say the trove of 39 gold and 70 silver coins was minted in the middle of the first century B.C. as the future Roman ruler Julius Caesar led a campaign against Celtic tribes in the area.

Curfs said he was walking with his detector this spring and was about to go home when he suddenly got a strong signal on his earphones and uncovered the first coin.

"It was golden and had a little horse on it - I had no idea what I had found," he said.

After posting a photo of the coin on a Web forum, he was told it was a rare find. The following day he went back and found another coin.

"It looked totally different — silver, and saucer-shaped," he said. Curfs notified the

city of his find, and he and several other hobbyists helped in locating the rest of the coins, in cooperation with archaeologists.

Nico Roymans, the archaeologist who led the academic investigation of the find, believes the gold coins in the cache were minted by a tribe called the Eburones that Caesar claimed to have wiped out in 53 B.C. after they conspired with other groups in an attack that killed 6,000 Roman soldiers.

The Eburones "put up strong resistance to Caesar's journeys of conquest," Roymans said.

The silver coins were made by tribes further to the north — possible evidence of cooperation against Caesar, he said.

Both coin types have triple spirals on the front, a common Celtic symbol.

The two other known caches of Eburones coins have been found in neighboring Belgium and Germany.

Maastricht city spokeswoman Carla Wetzels said the value of the coins is not known — their worth is primarily historical. The Belgian cache of similar size was estimated at around 175,000 euros (\$220,000).

The farmer who owned the land agreed to sell his interest to the city for an undisclosed sum.

Curfs, a teacher at a nearby junior

college, continues to own the 11 coins he found, but has lent them to the City of Maastricht on a long-term basis. The coins will go on display at the Centre Ceramique museum in Maastricht this weekend.

Curfs said he considers his metal detector habit a meditative hobby and not an obsession.

Paul Curfs found these spectacular finds with his F75 metal detector.



*This hand out image made available by Amsterdam's Free University or VU and the city of Maastricht, Netherlands, Thursday Nov. 13, 2008, shows gold and silver coins. A hobbyist with a metal detector has found a cache of ancient Celtic and Germanic coins in a cornfield in the southern city of Maastricht. The city says the trove of 39 gold and 70 silver coins are dated to the middle of the first century B.C. The hobbyist, Paul Curfs, 47, found several coins this spring and called attention to the find, which eventually led to an archaeological investigation by Amsterdam's Free University. (AP Photo/ VU/Gemeente Maastricht, HO)*

## Coins and Relics found with the F-series

Gene Scullion shares some of his recent Fisher F75 & F70 metal detector finds.



**John & Bob's finds from a civil war camp, using their F70 & F75 detectors**



Everyone else gave up on the "hunted out" camp; it had become almost impossible to find a target. We knew that for certain because we had covered it many times with many different detectors. The F75 and F70 made it seem virgin again and produced lots of targets including 3 hard to find, One dollar gold coins! Thanks Fisher!

**Randall Stoeberl from Spring Creek, NV finds 33.5 ounces of gold with Fisher's Gold Bug 2**

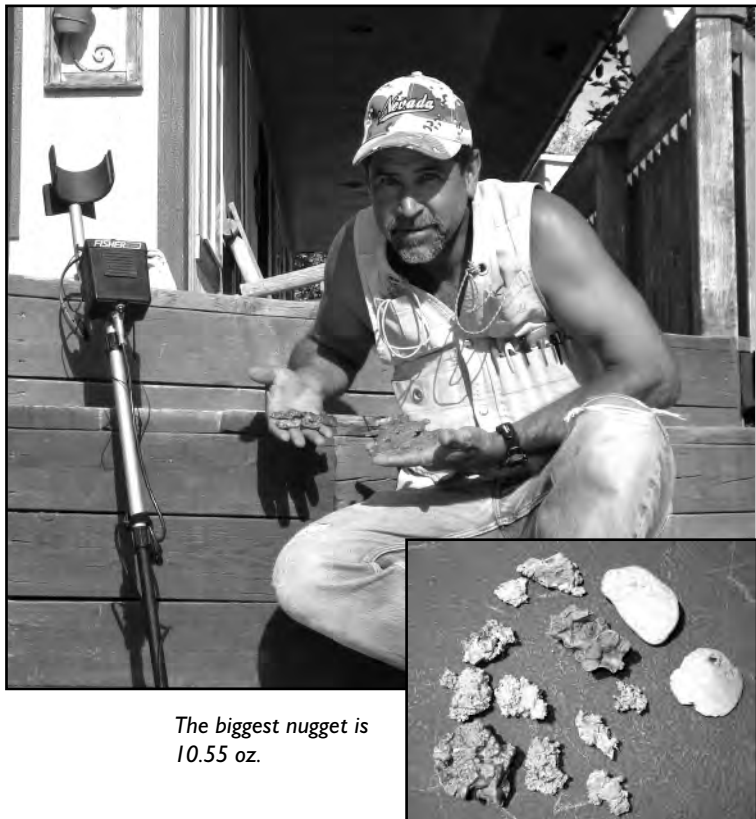

The biggest nugget is 10.55 oz.



## Coins and Relics found with Fisher Detectors



1793 Spanish Real found by Bobby Laluna.



Cufflink found by Douglas Langley.



Confederated Civil War Buttons and Buckle found by Rob.



Red Legs Team along with other Fisher team members were - Treasure Week Competition Champions.



Masonic cufflink, South Carolina 3rd Regiment Revolutionary War button & slave tag found by Peter Eles in South Carolina.



Rare Confederate Artillery Button found by Eddie Moss.



Early buttons & cufflink found by Peter Eles, South Carolina.

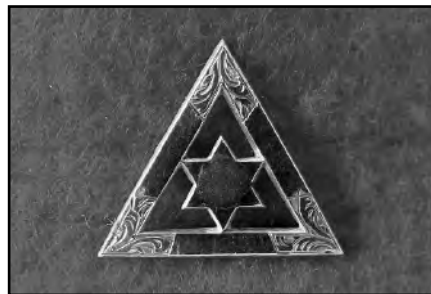

Jewish pendant found by Rob.



Civil War relic found by Bob.

## Fabulous Finds with Fisher Detectors



Gold nugget found by Andy Angus.



Silver fur trade era cross.



1652 Tree Coin.



Early coin spill found by Kim Cox.



Another gold nugget found by Mike Swinnie.



Civil war buttons.



Confederate Calvary Button found by Greg Toney.



Men's gold and diamond ring.



Gold jewelry.



Flintlock musket hammer.



South Carolina Continental Navy Button found by Pete Eles.



Milk can silver cache, found with a Gemini 3.



1700's Jesuit rings.

## OUR FRIENDS IN NORWAY

TEAM-UP FOR SOME HUNTING TIME AND GREAT FINDS



"Beginner's luck". Lise Nakken showing a coin find.

Lise Nakken Soeraker using a Bounty Hunter Tracker 4 metal detector.

Mr. Per Sibe using an F5.



Per Sibe is geared up with his CZ-21 for some water adventure.



Per Sibe collects the rewards after the hunting fun.



Lise Nakken showing yet another find.

# Fisher F5 Review

Mark Ellington

Okay...are you ready for this? I'm going to open this F5 review with a very bold statement. *The new Fisher F5 has the BEST user interface of ANY metal detector I've ever used!*...and I've used a bunch!

The Fisher F5 is yet another weapon in Fisher's ongoing "War on bad ergonomics and interfaces" that tends to plague the hobby industry. The absolute brilliance of the design makes me wonder "why in the world hasn't someone already done this?" Sure...hobby detectors have used knobs in the past to control functions (like Fisher's own venerable CZ series), but never before has there been this perfect storm of digital, software driven power combined with ease tactile knob control.

The F5 knob settings are instantly relayed to the user in a window in the bottom left of the display (Setting). When you give the gain a tweak, the window intelligently switches to the gain setting... adjust the ground balance, it shows you that too! The same goes for Threshold, Discrimination, Tones and more. When you're not adjusting something, the window displays the current ground "Phase" setting. It's a great concept... all adjustments can be made on the fly, and you're instantly informed of what you're changing (and by how much).

Each of the knobs on the F5 is strategically

placed so you can "thumb" the controls. If I hear a deep target that is on the fringe of detection, I don't have to dig through layers of menus to adjust the gain or threshold...a quick reach with the thumb of my detecting hand and I can ease the controls up quickly and efficiently! When I'm done, it's a very simple task to "thumb" it right back to my starting point.

Speaking of gain and threshold, the F5 places these two control knobs side-by-side for a reason. There is a very synergistic relationship that has to be seen to be believed! High gain or high threshold...which will be best for my current hunting site? The flexibility offered for adapting to all your various hunt sites and their challenges are incredible. There is a local farm that I hunt that is surrounded by an electric cattle fence. I have had to hunt this spot with ridiculously low settings on older detectors just to make it bearable. With the F5, I can adjust the Threshold control to around -1 or -2 and

still get very impressive depths!...Without the noise and chatter this spot usually bombards me with. Since using the F5 in this pasture, I've recovered several old silver coins that I just could not hear with my older detectors!

The threshold control also does something else. Have you ever hunted a site that drove you nuts due to tiny bits of foil, rusted tin, etc.? By lowering the Threshold control, you can partially reduce the F5's sensitivity to 'em! As a precaution, I tested this in my coin garden to see if it would have a major impact on the depth I could get on coin sized targets. Although there was a very slight loss of depth, I was still able to hear coin sized stuff within about 1/4 of an inch of the "zero" setting on the threshold (this was adjusting the threshold to around -2 or -3...plenty to get rid of the tiny stuff on most sites).

The audio on the F5 is amazingly descriptive. You have the option to choose single, two, three or four tones. However, there's a lot more to the F5 audio than just the number of tones! There are some amazing tonal qualities that change according to the cleanliness of the signal, proximity to other targets, tone mode selected, etc. I'm reminded of a few old analog detectors I've owned that, although a single tone gave me a lot of information about the target due to the "little things" you hear in the audio. In other words, there's much more



going on here than just "BEEP!" on a target.

Another super-cool feature on the F5 is the "Phase Lock" button. I mentioned earlier that the F5 has a brilliant user interface. The F5 is also spectacular in another area... user information! The F5 feeds the hunter with important data in "real time". The "Phase Lock" button allows you to "grab" one of these real-time bits of information...the phase reading! Phase and ground balance are nearly synonymous (at least in practical use terms). While hunting, you can glance at the "Phase" reading on the right, and if it is several numbers off from the static ground balance reading in the "Setting" window, you have two options. One is to manually tweak the GND BAL knob to match the setting, or my favorite method, a quick press of the "Phase Lock" button, and it's set for you!

You have the usual TID (Target Identification) on the big, clear LCD screen (Visual ID is also in all-metals mode!), but you also have other key bits of intelligence streaming to you. One is the  $Fe_3O_4$  bar on the GND DATA window on the right. This

tells the user about the amount of "magnetite" in the soil, which can affect the accuracy of the target ID circuits in the F5. The other is the previously mentioned "Phase" reading, and lastly there's the "Confidence" bar. The bar tells me how "sure" the detector is that the target identified along the TID arc (Fe, Foil, Tab, 5ct, etc.) is indeed what it says it is. It is yet another piece of information for the user to add to his/her list of "evidence" when investigating a possible goody! Really deep targets, and targets partially "masked" by other junk items can fool even the best, so good practice is "when in doubt...DIG!"

Hunting with the F5 is sheer, ecstatic joy! The weight and balance are great...the controls intuitive and useful...the ground and target information...actually practical! Minutes can turn into hours while hunting without the usual fatigue setting in...a testimony to a metal detector that has both the physical stuff right (weight, balance and ergonomics), as well as the abstract stuff...(Can I call it "mental and emotional" fatigue?). I have hunted with detectors in the past that "wore me out!" both physically

and mentally due to bad physical design, constant chatter and horrible menu systems that made you have to dig through layer after layer to change something. NOT so with the F5!

## Summary

The new Fisher F5 is a metal detector that will set a benchmark for its incredibly well designed interface. I can see new metal detectorists and veterans having a blast with it, as well as anyone who just likes the feel of knobs better than button pushing their way through menus. All the control is there for the power user...but in a whole new way! "Intelligent simplicity" may sum up the F5 quite well! I find it very ironic that Fisher Labs, the "Oldest name in Metal Detecting" is on the cutting edge of the newest technology! I very vigorously tip my hat to Jorge Anton Saad who was Lead Engineer on the F5 project...and well supported by the legendary Dave Johnson, John Gardiner, Mark Krieger and Marvin Jones. A job well done on what is sure to become a favorite metal detector for a lot

## *Proud descendents of the Teknetics Tradition* Performance, Quality and Superiority



# TEKNETICS

M E T A L   D E T E C T O R S

1-800-413-4131

## Discrimination mode “Sensitivity” and “Depth” in single-frequency VLF metal detectors

by **Dave Johnson**

Chief Designer, Fisher Research Labs

Some metal detectors are “more sensitive” than others, and “how deep” a particular metal detector can detect a specific metal object depends on many variables.

“Air test sensitivity” refers to the maximum repeatable detection distance achievable in air using a standard metal test piece (typically a US nickel coin), with the searchcoil that’s standard with that model, in a location without electrical interference, the machine adjusted to just barely eliminate background chatter. If ground balancing is available on the machine, it must be done using ferrite. .... A properly done “air test” provides an indication of a machine’s potential to “go deep” on buried coins. Because of interference from magnetic iron minerals in the ground, actual detection depth will usually be much less than what’s achieved in “air test”. (NOTE: for maximum depth on buried objects, search in the all-metals ground balanced mode, which is much less affected by iron minerals.)

“Sensitivity control” A control labeled “sensitivity”. It actually controls either gain or threshold, or a combination of both, depending on the machine. If both, the higher settings vary threshold and the lower settings vary gain.

“Audio threshold control” Determines the signal strength level corresponding to the threshold of audibility. A negative threshold setting is used to suppress signals by a fixed amount so that only signals stronger than that amount will be heard. Negative threshold settings are used to silence internal “circuit noise” and electrical interference. Machines which have no threshold control have an internal threshold which allows silent operation, or a control labeled “sensitivity” which actually controls threshold. ....Some models allow positive

threshold settings. In most cases the positive range controls the loudness of a minimum detectable signal, a separate internal threshold determining what will or will not be detected.

“Gain control” This makes signals bigger or smaller. High gain settings make signals bigger, and therefore signals which were originally weaker can more easily exceed the audio threshold, and be heard. If the gain setting is too high, electrical interference or internal circuit noise may cause constant audio chatter. ....Lower gain settings reduce the size of signals, so that relatively weak unwanted signals (electrical interference, deep iron fragments, aluminum foil shreds, etc.) can be silenced.

The effects of discrimination “Discrimination” between different metal objects is done using a different set of signals than the ones used for detection. Since the overall purpose of discrimination is to eliminate response to certain classes of metal objects beginning with metallic iron, magnetic iron minerals in the ground will tend to make nonferrous metal signals look more like ferrous, increasing the probability of their being rejected by the discrimination circuit. Some machines provide data on the amount of iron mineralization, so with experience you can estimate the depth of effective detection and discrimination on that site.

Interactions between controls There are many types of discriminators, all of which have some effect on “air test sensitivity”. The most common pattern (nearly universal in older all-analog machines) is that “air test sensitivity” decreases slightly as discrimination is increased. Most of our recent designs do discrimination entirely in software, where control settings are actually data which don’t necessarily do the same things to signals that circuit components used to do. In the case of the T2 and F75, those differences were confusing to some

users. In general if a T2 or F75 seems too noisy, the solution is to set the discrimination level to the iron range; and if that doesn’t do the job, also reduce the sensitivity setting. In the F70 and F5 which are more recent designs, the interactions between control settings and signals are even more complex, but we did a better job of hiding the details thereby giving the user an improved sense of predictability.

Electrical interference In many (probably most) machines, elimination of electrical interference is best achieved by setting the discrimination level to the top of the iron rejection range, then reducing the threshold setting (if threshold control is available; it may be labeled “sensitivity”). Even if the machine chatters in air, while actually in motion searching over the ground it will usually quiet down, except for occasional random pops which don’t sound like targets. (Frequency shifters found on some machines are beyond the scope of this essay.)

How much depth should I get? There is no single answer to that question. In a few places, you may get in-ground depth almost as good as in an air test. There are also a few places with so much iron or salt mineralization that most detectors are not even usable. In most soils, the best discriminators will usually detect coins to a depth of 7 inches or more, and will usually provide usable discrimination and target ID to a depth of 5 inches or more. However, a particular target may not be detected or may be misidentified because of the proximity of rocks or other metal targets, disturbed soil caused by digging, peculiarities of the target, or suboptimal user technique for that target in that setting. On sites where the discriminator doesn’t provide enough depth for your purposes, search in the all-metals ground balanced mode if the machine provides one.



ACTUAL PRODUCTS SHIPPED MAY VARY SLIGHTLY FROM IMAGES SHOWN

Description	Item #	Retail	Description	Item #	Retail
1 Padded Carrying Bag	103693000C	\$ 45.00	6 Lesche digging knife	LESCHER KNIFE	\$49.95
2 Fisher Head Phones	9720971000	\$100.00	7 Fisher Baseball Cap		\$14.95
3 Stereo Head Phones	9720950000	\$ 40.00	8 Fisher Apron		\$ 5.95
4 Pin Pointer	PINPOINTER	\$ 69.00	9 Fisher T-Shirt sizes: L, XL, and XXL		\$19.99
5 Metal Sand Scoop	SAND SCOOP	\$ 29.99			

For Accessory Coils please go to page 24 -29

\* Coil covers available for purchase, please ask customer service representative for complete details



**Fisher Labs**  
METAL DETECTORS

## F75

MSRP \$1199.00

### The Ultimate Detector

F75  
11"  
DD Coil

- Double-D search coil
- Trigger-actuated FASTGRAB™ ground balance
- Double-filter discrimination modes for searching in trashy areas
- Magnetic mineralization bar graph read out
- Frequency shift for eliminating electrical interference and crosstalk
- Visual target ID by category & 0-99 indication, both discrimination & auto-tone modes
- Trigger-actuated target pinpointing with variable audio pitch
- Non-volatile memory saves settings
- Backlight
- Low operating cost - typically 40+ hours with 4-AA batteries
- Large LCD screen with target identification display
- Rain cover for control housing & battery housing available
- 13 kHz frequency— good for coin shooting, relic hunting, and gold prospecting

#### Accessory Coils:

5" DD Coil . . . . . MSRP **\$159.00**  
 6 1/2" Elliptical Coil . . MSRP **\$169.00**  
 10" Elliptical Coil . . . MSRP **\$179.00**



## F70

MSRP \$799.00

### The F70 has many great features.

Use it for coin shooting, relic hunting, gold prospecting, and much more!

F70  
10"  
Elliptical  
Coil

- 13 kHz frequency— good for coin shooting, relic hunting, and gold prospecting
- Frequency shift for eliminating electrical interference and crosstalk
- Visual target ID by category & 0-99 indication, both discrimination & auto-tone modes
- High-resolution push-button ground balance with ground balance readout
- Ground balance range goes all the way to salt
- Continuous display of ground mineral concentration
- Independent sensitivity and threshold settings provide fine control over response
- Speed selection— normal for most situations, slow for deep coins in non-trashy areas
- Great ergonomic design
- Low operating cost - typically 40+ hours with 4-AA batteries
- Switch back and forth between two programs; saves both programs when powered off

#### Accessory Coils:

5" DD Coil . . . . . MSRP **\$159.00**  
 6 1/2" Elliptical Coil . . MSRP **\$169.00**  
 11" DD Coil . . . . . MSRP **\$199.00**





**F5**

*Combining the best in analog and digital technology*

- Frequency shift for eliminating electrical interference and crosstalk.
- Advanced software-based motion discrimination with notch for searching trashy areas.
  - All metals auto-tone mode for deep-searching in non-trashy areas.
  - Visual target ID by category & 0-99 indication, both discrimination & auto-tone modes.

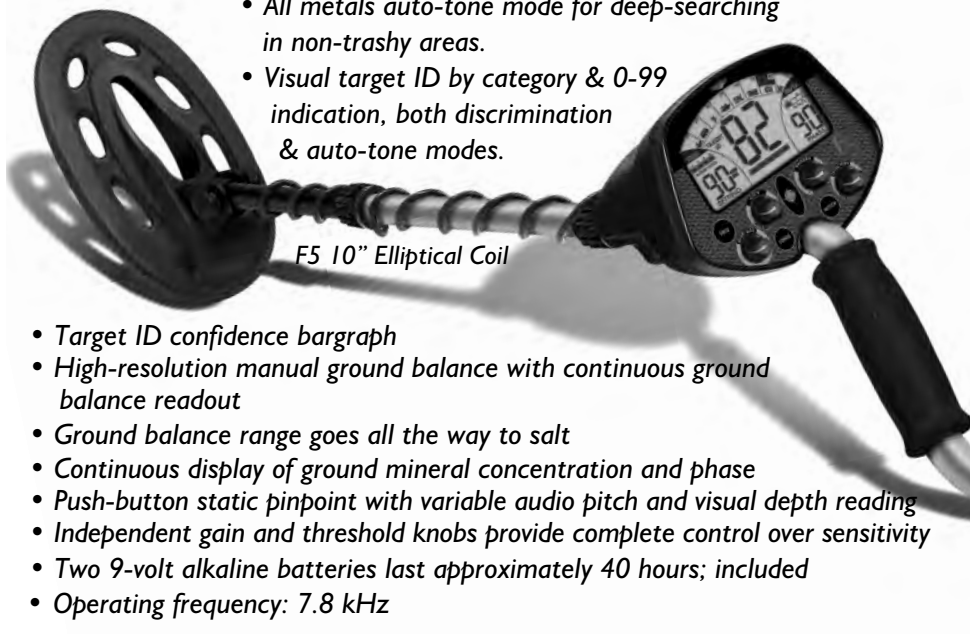

- Target ID confidence bargraph
- High-resolution manual ground balance with continuous ground balance readout
- Ground balance range goes all the way to salt
- Continuous display of ground mineral concentration and phase
- Push-button static pinpoint with variable audio pitch and visual depth reading
- Independent gain and threshold knobs provide complete control over sensitivity
- Two 9-volt alkaline batteries last approximately 40 hours; included
- Operating frequency: 7.8 kHz

**MSRP \$549.00**



**Accessory Coils:**

- 5" DD Coil . . . . . MSRP **\$159.00**
- 8" Coil . . . . . MSRP **\$119.99**
- 11" DD Coil . . . . . MSRP **\$199.00**

**F4**

*Great all purpose detector*



- 11-Segment digital target identification and 4-tone audio I.D.
- 2-digit numeric target value
- One-touch notch immediately eliminates unwanted targets
- Fisher's deep-seeking auto-tone mode with manual ground balance
- One-touch pinpoint
- Coin depth indicator
- Two 9-volt alkaline batteries; included
- Operating frequency: 5.9 kHz

**MSRP \$449.00**



**Accessory Coils:**

- 4" Coil . . . . . MSRP **\$39.99**
- 8" Coil . . . . . MSRP **\$59.99**
- 10" Coil . . . . . MSRP **\$69.99**

## F2

### Versatile Multipurpose Performance

**MSRP \$249.00**

F2  
8" Coil



- 8-Segment visual target identification and 4-tone audio I.D.
- Fast, sensitive target response
- 2-digit numeric target value
- One-touch pinpoint with numeric depth readout
- Coin depth indicator in motion search mode
- 8" concentric searchcoil
- Light weight - only 2.6 lbs including batteries
- Ergonomic S-Handle design
- Notch system for accepting or rejecting target categories
- Includes two 9 volt alkaline batteries
- Operating frequency: 5.9 kHz

#### Accessory Coils:

4" Coil . . . . . MSRP **\$39.99**  
 10" Coil . . . . . MSRP **\$69.99**  
 11" Coil . . . . . MSRP **\$149.99**



## Gold Bug-2

The most sensitive gold hunting detector ever made

**Choice of 6 1/2" or 10" coil MSRP \$899.00**
**GOLD BUG 2 COMBO includes both 6 1/2" & 10" \$999.00**

#### Accessory Coils:

6 1/2" Coil . . . MSRP **\$143.95**  
 10" Coil . . . MSRP **\$143.95**  
 14" Coil . . . MSRP **\$164.95**



BGB 10" Coil



- Extreme Sensitivity to Small Gold Nuggets
- High Precision Dual-Control Ground Balance
- Iron Disc Mode for Iron & Hot Rock Rejection
- Deep Target Audio Boost
- Lightweight & Hip-Mountable
- Available with either a 6 1/2" or a 10" elliptical search coil
- Operating frequency: 71 kHz

Premium underwater detector  
whether it be dry land,  
saltwater or fresh water,  
the CZ-21 delivers

## CZ-21 Quick Silver

with 8" coil MSRP \$1299.00  
with 10" coil MSRP \$1349.00

Multi Frequency



CZ-21 8" Coil



- Saltwater or fresh water
- Submersible up to 250 feet
- Dual frequency Fourier Domain signal analysis
- Contact button, VCO no motion, precise pinpointing
- Easy manual ground balance
- High performance in mineralized soil
- All-metal auto-tone mode
- Large target alert / faint target audio boost
- 3-tone audio target ID
- Removable control housing for belt mount
- 8" and 10" coil options
- Operating frequency: 5 and 15 kHz

Proven performance  
on land or in  
water

## 1280-X

with 8" coil MSRP \$799.95  
with 10" coil MSRP \$829.95



1280X 8" Coil



- Submersible up to 250 feet
- Turn On & Go Operation
- Submersible for Underwater Treasure Hunting
- Full Range Target Discrimination
- Adjustable Sensitivity Control
- Audio & Visual Target Response
- VLF Discrimination
- Operating frequency: 2.4 kHz
- Up to 75 hours of battery life

## 1270-X

Legendary relic hunting performance

MSRP \$699.95

**Accessory Coils:**  
 5" Series Coil . . . MSRP \$99.95  
 10 1/2" Series Coil MSRP \$129.95



1270X  
8" Coil

- Extreme Depth
- Excellent See-Through in Iron Trash
- Enhanced Sensitivity to Relics
- Deep Seeking All-Metal or Enhanced Disc. Modes
- Trigger Switch for Rapid Dual-Discrimination Operation or Precision Pinpointing
- Operating frequency: 8.2 kHz



## CZ-3D

Coin, relic & saltwater beach hunting specialist

MSRP \$949.95

**Accessory Coils:**  
 5" CZ Coil . . . . MSRP \$109.95  
 10 1/2" CZ Coil . . MSRP \$129.95

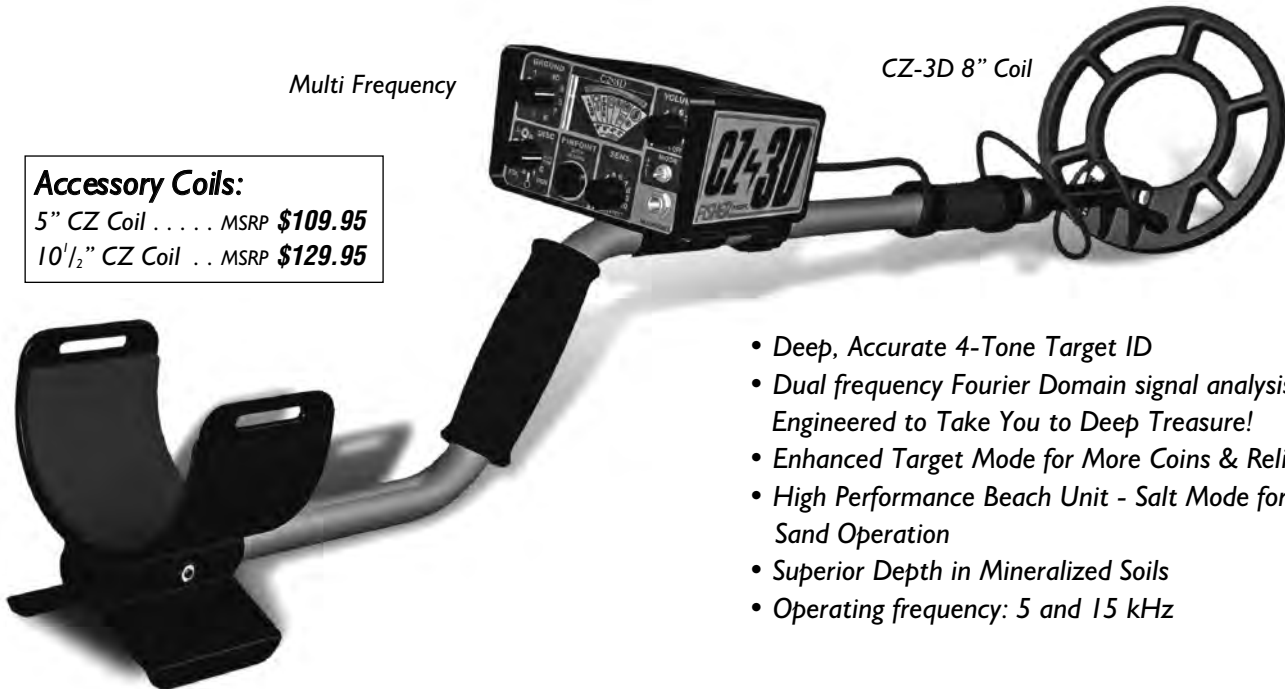

Multi Frequency

CZ-3D 8" Coil

- Deep, Accurate 4-Tone Target ID
- Dual frequency Fourier Domain signal analysis, Engineered to Take You to Deep Treasure!
- Enhanced Target Mode for More Coins & Relics
- High Performance Beach Unit - Salt Mode for Wet Sand Operation
- Superior Depth in Mineralized Soils
- Operating frequency: 5 and 15 kHz



*The deepest treasure finder*

## Gemini-3

MSRP \$799.00

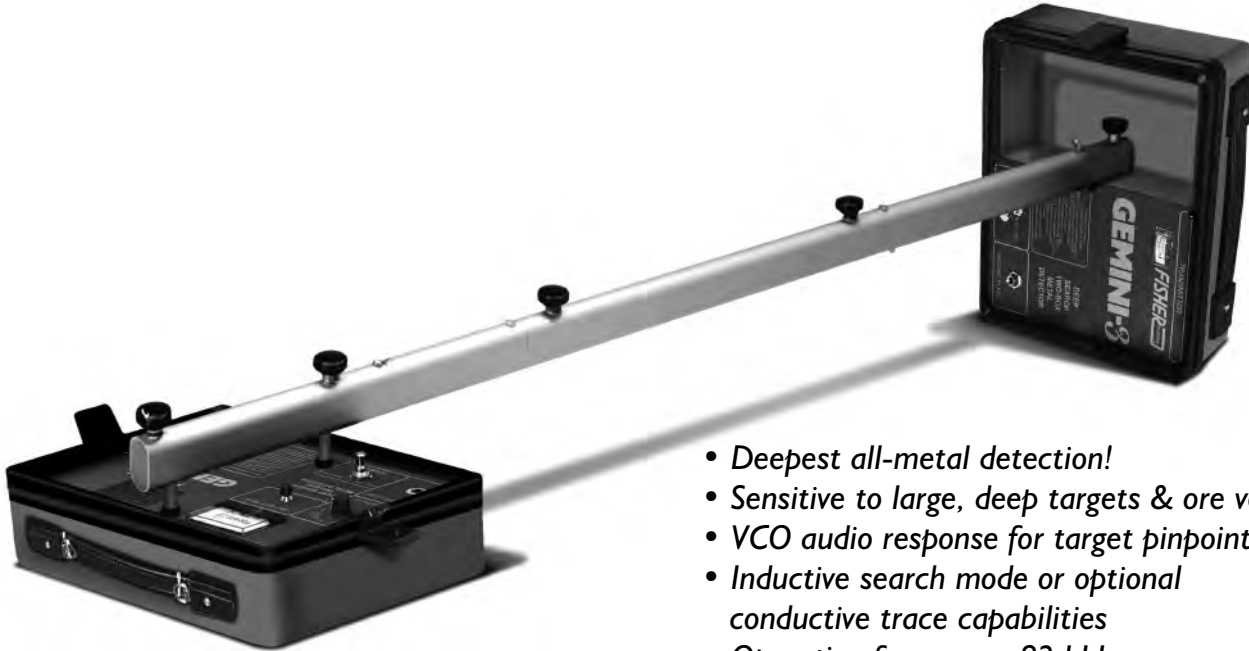

- *Deepest all-metal detection!*
- *Sensitive to large, deep targets & ore veins*
- *VCO audio response for target pinpointing*
- *Inductive search mode or optional conductive trace capabilities*
- *Operating frequency: 82 kHz*

## BE PART OF THE TEAM

**BE PART OF A COMPANY WITH OVER 70 YEARS IN UNDERGROUND DETECTION. FISHER RESEARCH LABS IS LOOKING FOR DEALERS TO REPRESENT OUR PRODUCTS IN THE U.S.A. AND OVERSEAS. DON'T MISS THE OPPORTUNITY TO BE A PART OF THE FISHER TEAM.**



World's Most Experienced Manufacturer of Metal Detectors  
1465-H Henry Brennan, El Paso, TX 79936 • 1-800-685-5050

## Metal Detector's Code of Ethics

1. Always check Federal, State, County and local laws before searching.
2. Respect private property and do not enter private property without the owner's permission.
3. Take care to refill all holes and do no damage.
4. Remove and dispose of any and all trash and litter found.
5. Appreciate and protect our inheritance of natural resources, wildlife and private property.
6. Act as an ambassador for the hobby, use thoughtfulness, consideration and courtesy at all times.
7. Never destroy historical or archeological treasures.
8. All treasure hunters may be judged by the example you set; always conduct yourself with courtesy and consideration for others.

**ALABAMA**

**Southern Treasures**  
930 Hillcrest School Rd  
Tuscaloosa, AL 35405  
(866) 849-7732  
streasures930@bellsouth.net  
http://www.southern-treasures.com

**ALASKA**

**Alaska Mining & Diving Supply**  
3222 Commercial Dr  
Anchorage, AK 99501  
(907) 279-0127

**Joe's Mining & Diving**

PO Box 1125  
Kenai, AK 99611  
(907) 283-7808

**ARIZONA**

**A & B Prospecting**

3929 E Main St #32  
Mesa, AZ 85205  
(480) 832-4524

**Back Country Prospectors**

P.O. Box 586  
Congress, AZ 85332  
(208) 739-8689

**De Torres Detectors**

2008 11th Ave  
Yuma, AZ 85364  
(928) 782-2480  
detorres@digitaldune.net

**Double H Leather Works**

3017 Robert Rd Suite C  
Prescott Valley, AZ 86314  
(928) 632-8560

**Gold Miser**

P.O. Box 2798  
Quartzsite, AZ 85346  
(928) 927-7150  
goldmiser@netscape.net

**Morey Detector Sales**

3818 E Hardy Dr  
Tucson, AZ 85716  
(520) 323-0071  
wmoreysr@msn.com

**ARIZONA**

**Pro Mack Prospecting LLC**

4650 N Mammoth Mine Rd  
Apache Junction, AZ 85219  
(480) 983-7011  
promack@quik.com

**CALIFORNIA**

**A & S Company**

3209 Benton Street  
Santa Clara, CA 95051  
(888) 369-8999  
sean20@ix.netcom.com

**Big Valley Metal Detectors**

8153 Julie Ct  
Citrus Heights, CA 95610  
(916) 225-9150  
webmistress@bigvalleymetaldetectors.com  
www.bigvalleymetaldetectors.com

**Columbia Metal Detectors**

760 E Valley Pkwy  
Escondido, CA 92025  
(760) 743-8516

**Johnny's Metal Detectors**

1208 W. Cook St  
Santa Maria, CA 93458  
(805) 348-1214  
johnnysdetectors@hotmail.com

**Legends Prospecting Supplies**

207 Cavendish Dr  
Hemet, CA 92545  
(951) 929-1826  
info@legendsprospectingsupplies.com  
www.legendsprospectingsupplies.com

**The Pawn Shop**

1150 Broadway  
Atwater, CA 95301  
(209) 352-1333  
ggose@live2wire.com

**Trans Bay Metal Detector**

321 Sea Horse Ct  
Foster City, CA 94404  
(650) 574-2012  
au4greg@sbcglobal.net

**Treasure Trove**

3538 University Ave  
San Diego, CA 92104  
(619) 283-7139  
hot329@aol.com  
www.treasuretroveauctions.com

**COLORADO**

**Gold-N-Detectors**

802 Washington Ave  
Golden, CO 80401  
(303) 278-6622  
bill@goldendetectors.com

**CONNECTICUT**

**T.C. Metal Detectors**

23 Cornwall Dr  
Windsor Locks, CT 06096  
(860) 623-1153  
capaction@aol.com

**DELAWARE**

**Sea Shell City, Inc.**

708 Ocean Highway  
Fenwick Island, DE 19944  
(302) 539-9366

**FLORIDA**

**Bob Uhl's Detector Sales**

414 Galloway Rd  
Lakeland, FL 33813  
(863) 687-2199  
buhlinfo@aol.com

**Emerald Coast Coins, LLC.**

7141-A North 9th Ave  
Pensacola, FL 32504  
(850) 473-1515  
steve@emeraldcoastcoins.com

**Famous Treasure**

4312 Land O Lakes Blvd  
Land O Lakes, FL 34639  
(813) 996-1787  
sales@famoustreasures.com

**Kellyco**

1085 Belle Ave  
Winter Springs, FL 32708  
(800) 327-9697  
john@kellycodetectors.com

**Reilly's Treasured Gold, Inc.**

2003 W Mc Nab Rd #10  
Pompano Beach, FL 33069  
(954) 971-6102  
rtgsales@rtgstore.com

**T & D Suppliers, Inc.**

1339 SW 30th Ave Bay #8  
Boynton Beach, FL 33426  
(800) 249-4231

**GEORGIA**

**Bonnie Blue Metal Detectors**

157 Rock Store Rd  
Dallas, GA 30132  
(404) 556-1480

**North Georgia Relics & Detectors**

5532 Battlefield Pkwy  
Ringgold, GA 30736  
(706) 264-6011  
northgeorgiarelics@charter.net

**Southern Metal Detectors & Collectibles**

4759 North Springs Rd  
Kennesaw, GA 30144  
(770) 517-0427  
info-southernmetal@comcast.net  
www.southernmetal.com

**IDAHO**

**Gerry's Metal Detectors**

1101 N. 15th St  
Boise, ID 83702  
(208) 345-8898  
gerrys1det@cableone.net  
www.gerrysdetectors.com

**ILLINOIS**

**Warner Distributing**

1238 Allanson Rd  
Mundelein, IL 60060  
(847) 566-4141  
scott-warner@comcast.net

**Windy City Detector Sales**

6435 N Newark  
Chicago, IL 60631  
(773) 774-5445  
windycitydetectors@yahoo.com

**INDIANA**

**NWI Detectors**

183 East 600 South  
Valparaiso, IN 46383  
(219) 766-2879  
nwidetectors@yahoo.com

**KANSAS**

**Lynn Peavey Company**

10749 West 84th Terrace  
Lenexa, KS 66214  
(913) 888-0600

**MARYLAND**

**Finders Keepers**

401 Beach Dr  
Edgewater, MD 21037  
(410) 798-1833  
lil-john@att.net

**Rebel Metal Detectors**

340 Butternut Ct  
Millersville, MD 21108  
(410) 987-0502  
steve@rebelmetal.com

**MASSACHUSETTS**

**Colonial Metal Detectors**

34 Summer St  
Blackstone, MA 01504  
(508) 883-8232  
colonialdetect.@aol.com

**Detector Electronics Corp.**

P.O. Box 2132  
Framingham, MA 01703  
(508) 460-6244  
dan@metaldetector.com  
michaelsb@metaldetector.com  
www.metaldetector.com

**Surfscanner Detector's**

24 River Hill Rd  
East Falmouth, MA 02536  
(508) 457-4805  
wcrabtre@comcast.net  
www.surfscanner.com

**MICHIGAN**

**DM Bargain Xchange**

2542 Windview SW  
Wyoming, MI 49519  
(616) 531-7571  
obx616@yahoo.com

**ProStock Detectors**

1211 1/2 W. M- 89  
Plainwell, MI 49080  
(269) 685-1776  
prostock@net-link.net

**Treasures Down Under**

104 S Broadway St  
Cassopolis, MI 49031  
(269) 445-1577  
treasuresdownunder1@verizon.net

**If information listed is incorrect or needs updating, please email mscott@frsttx.com with your latest information.**

## MISSISSIPPI

### Forestry Suppliers

PO Box 8397  
Jackson, MS 39284  
(601) 354-3565

## MISSOURI

### Clevenger Detector Sales

8206 North Oak Traffic Way  
Kansas City, MO 64118  
(800) 999-9147  
ccmo63@aol.com

### Pictures & More

1541 E 559th Rd  
Brighton, MO 65617  
(417) 376-2159

### The General Exchange

5411 Sawyer St  
St. Joseph, MO 64504  
(816) 273-4528  
thegeneralexchange@hotmail.com

## MONTANA

### Modern Prospectors

2210 North Cooke  
Helena, MT 59601  
(406) 442-0044

### Prospectors Shop

6312 Highway 12 West  
Helena, MT 59601  
(406) 442-1872

## NEBRASKA

### Net Shops

12720 I St, Suite 200  
Omaha, NE 68137

## NEVADA

### Gotta Getta Map

361 Frontage Rd #2  
Pahrump, NV 89048  
(775) 727-3773  
gottagettagamap@prodigy.net

### Star Point Trading Post

150 Hwy 400  
Mill City, NV 89418  
(775) 538-7677  
dustismakesignal@hotmail.com

## NEW HAMPSHIRE

### Treasure Sales

148 Kings Highway  
Hampton, NH 03842  
(603) 926-2305  
vicwreck@aol.com  
www.shipwreckhunter.com

## NEW YORK

### Metal Detector Distributing

9203 Flatlands Ave  
Brooklyn, NY 11236  
(718) 649-5872  
metdetdist@aol.com

### Upstate Detectors

1343 Sumner Ave  
Schenectady, NY 12309  
(518) 393-0624  
carl@upstatedetectors.com  
www.upstatedetectors.com

## NORTH CAROLINA

### Barbee Detector Sales

3452 Garden Rd  
Burlington, NC 27215  
(888) 717-6188

### Sirchie Finger Print Labs

100 Hunter Place  
Youngsville, NC 27596  
(919) 554-2534  
sirchieusa@mindspring.com

## OHIO

### Baringer's Metal Detectors

P.O. Box 55  
Kidron, OH 44636  
(330) 857-8479  
billypatch@aol.com

## OREGON

### Belda's Detector Sales

60442 Zuni Rd  
Bend, OR 97702  
(866) 301-8552  
goldbummin@bendbroadband.com  
www.goldbummin.com

### Bill & Ruby's Rock & Ore House

PO Box 2191  
Myrtle Creek, OR 97457  
(541) 863-6111

## OREGON

### Blue Bucket Metal Detectors

14996 Pine Creek Lane  
Baker City, OR 97814  
(541) 523-7406

### Cliff's Metal Detectors

4934 Center St NE  
Salem, OR 97301  
(503) 581-3395  
cliff4934@msn.com

### D & K Detector Sales

13809 SE Division St  
Portland, OR 97236  
(800) 542-4653  
sales@dk-nugget.com  
www.dk-nugget.com

### K & D Detector Sales

78634 Rontala Rd  
Clatskanie, OR 97016  
(503) 728-2094  
dkdist@clatskanie.com

### Oregon Prospecting

1045 Main St  
Sweet Home, OR 97386  
(541) 367-2237  
gold2@centurytel.net

## PENNSYLVANIA

### Burke's Pot O' Gold

84 S Atherton Ave  
Kingston, PA 18704  
(570) 331-0600

### Gettysburg Electronics

24 Chambersburg St  
Gettysburg, PA 17325  
(717) 334-8634  
hinks@pa.net

## SOUTH CAROLINA

### Relic Hunters Supply

263 Bird Island Rd  
Ridgeway, SC 29130  
(803) 427-5464  
clyde@relichuntersupply.com

## TENNESSEE

### Backwoods Detector Sales

221 Sunrise Circle  
Greenville, TN 37743  
(423) 360-1242  
nw4p@embarqmail.com

### Detector Depot

809 Brochardt Blvd  
Knoxville, TN 37934  
(865) 966-8442  
info@detectordepot.com  
www.detectordepot.com

## TEXAS

### American Detector Distributors

7816 College Circle  
N. Richland Hills, TX 76180  
(800) 933-2897  
wmrobt@email.msn.com

### Jewelry & Coin Exchange

713 WSW Loop 323, Ste E  
Tyler, TX 75701  
(903) 534-5438  
jadeys101@suddenlinkmail.com

## UTAH

### J & J Metal Detectors

121 E Main St  
Sandy, UT 84070  
(801) 567-1122  
jjmtl@comcast.net

## VIRGINIA

### Aldridge Sales and Service

2411 Sherbourne Rd  
Richmond, VA 23237  
(804) 271-9523  
waynea2003@yahoo.com

### Sgt. Riker Trading Post

305 S Washington Hwy, Suite 1  
Ashland, VA 23005  
(804) 798-6848  
elrandino@sgtriker.com

## WASHINGTON

### Northwest Treasure Supply

PO Box 4212  
Bellingham, WA 98227  
(800) 845-5258  
bob@rcgold.com

## WISCONSIN

### Badger Metal Detectors

507 Woodstock Circle  
Madison, WI 53716  
(608) 213-6622  
badgermd@tds.net

### Outdoor Outfitters

824 N. Hartwell Ave  
Waukesha, WI 53186  
(800) 558-2020  
outdoorout@Ameritech.Net

## CANADA

### Canadian Treasure Seekers

601 St Clair Parkway  
Corunna, ON N0N 1G0  
(800) 965-8470  
canadiantreasureseekers@cogeco.ca

### Diversified Electronics

8521 Eastlake Dr  
Burnaby, BC V5A 4T7  
(604) 421-1234

### Golden Horseshoe Detector Sales

67 Richmond CR  
Stoney Creek, ON L8E 5T9  
(905) 643-2668  
czirakir@sympatico.ca

### Middlesex Detector Sales

35309 Cedar Swamp Rd  
Parkhill, ON N0M 2K0  
(519) 294-6623

To become an international  
dealer or distributor contact:

Masten-Wright, Inc.  
280 State St., Ste 202  
North Haven, CT 06473  
203-230-4130

Or

Fisher Lab directly  
1-800-685-5050  
Complete international  
dealer listing go to  
www.fisherlab.com

Contact or visit any one of our dealers listed here or for a complete dealer listing go to [www.fisherlab.com](http://www.fisherlab.com).

If information listed is incorrect or needs updating, please email [mscott@frsttx.com](mailto:mscott@frsttx.com) with your latest information.



# Fisher Labs WORLD TREASURE NEWS

In the late 1920's, Dr. Gerhard Fisher, a German immigrant who studied electronics at the University of Dresden, obtained the first patent ever issued on aircraft radio direction finders. He was working as a Research Engineer in Los Angeles, California at the time and his work attracted the interest of Dr. Albert Einstein. After a demonstration of Dr. Fisher's equipment, Einstein enthusiastically and correctly predicted the world-wide use of radio direction finders in the air, on land and at sea.

When using such direction finders during those early years, aircraft pilots found that errors would occur in their bearings when metal objects came between the transmitter and receiver, or whenever they passed over certain areas. Different pilots flying different planes always observed the same errors over the same places. When Dr. Fisher investigated this phenomenon, he found these errors to be the result of highly conductive, mineralized soils. Dr. Fisher concluded that a portable electronic prospecting instrument could be developed that used the same principle to detect the presence of small buried objects and ore deposits.

He continued his research into this phenomenon, and in 1931 he founded Fisher Research Laboratory in a garage behind his home at 1505 Byron St. in Palo Alto, California. He and four employees began producing the "Metallscope," starting each unit as a new order came in. The "Metallscope" was a rugged, easy-to-use metal detector. By today's standards, it was perhaps an ungainly device: two large, flat wooden boxes containing simple copper coils, five vacuum tubes, and a few assorted components. It soon captivated the imagination of the country, and within a short time, the world.

**USS MACON CRITICAL TOOL FOR DR. FISHER** Around 1933, the U.S. Navy hired Dr. Fisher to install a radio direction finder aboard the dirigible, the USS Macon. It was aboard the Macon that Dr. Fisher discovered that large metal buildings and mineralized mountains cancelled out the instrument's direction finding capabilities leading him to the discovery of the first metal detector. Dirigibles served the U.S. Navy as floating bases for scout planes during the 1930's, but the program was eventually abandoned. It became obvious that the highly touted U.S. Navy lighter-than-air program had a fatal flaw: dirigibles had a tendency to crash during severe weather.

By 1936, sales had increased to the point where the garage was no longer large enough. Fisher Research Laboratory moved to a small building at 745 Emerson St. in Palo Alto. Shortly thereafter, Dr. Fisher was granted a patent for his "Metallscope." The "Metallscope" was soon nicknamed the M-Scope, and as such, became an accepted standard for all types of electronic metal detection: geologists located ore, treasure hunters found treasure, utility companies located buried pipes, lumber mills located metal inclusions in sawn logs, and law enforcement agencies used it to locate abandoned or hidden weapons.

In 1939, just prior to World War II, Fisher moved to an even larger building at 1961 University Ave. in Palo Alto. During World War II and the subsequent Korean Conflict, the company was called upon to contribute its technical competence to the war effort, but the M-Scope business was never neglected. With the increasing popularity of the M-Scope, and with Fisher's patent rights expiring, numerous competitors began producing similar equipment. Due to relentless efforts to incorporate every available technical advancement - and in particular, by keeping close contact with countless users to utilize their vast fund of field experience in the design of new models - Fisher maintained its position of solid leadership. Over the years, Fisher has designed and produced such sophisticated products as geiger counters, radio communication systems, voltage detectors and cable fault locators.

In 1961, Fisher moved to an even larger production facility in Belmont, California. In 1967, Dr. Fisher retired, having firmly established his name in the annals of electronics history. The company continued to grow, and in 1974, Fisher Research Laboratory moved 90 miles southeast to Los Banos, California. In Los Banos from 1981-1995 the company had a senior electronics engineer by the name of David Johnson. David was the designer of many of the industry's most advanced metal detectors during this time and most of the legacy Fisher products still manufactured today are Johnson designs. This includes time tested technologies like the Gold Bug, "X" series and all incarnations of the CZ line.

In 2006 Fisher was purchased by First Texas Products (FTP) and the company moved to El Paso, TX. In a strange twist of fate, this sale reunited the now legendary David Johnson with Fisher Research Labs once again. David had already entrenched himself in metal detecting history as one of the most innovative detector designers over the past 28 years, having designed some of the best performing, best selling detectors for four of the major manufacturers.

David has been working as the Chief Design Engineer for Fisher Research Labs for a number of years with a team of talented engineers whom recently developed several new technologically advanced detector platforms for the company. Since 2006 Fisher has introduced many new Fisher products that have taken the industry by storm. In the last several years Fisher Research Labs has come out with more new products than the rest of the industry combined. Fisher Research Labs has already made detecting history and will continue to do so.

