



# Kalzip® FC façade system

Trendsetter for façade technology in  
aluminium





## Content

Page

### FC façade system – simple, flexible and economical

4

New buildings and renovation

4

The flexible VHF system in aluminium with freely selectable installation direction and simple panel replacement

5

Packaging and dimensions

6

Penetration-free fastening to modular rail

8

Well-thought-out system accessories for a perfect result

9

### The system in detail

10

Kalzip FC façade system – components

10

Sub-constructions

12

Structure of the FC façade system

14

Bi-directional panel installation

15

Dismounting of panels

16

5 reasons to plan with Kalzip FC

17

General instructions

18



# Clear and aesthetic – for an unmistakable character

The Kalzip FC façade system advances the technology of the rainscreen, rear-ventilated metal façade to the intelligent building envelope and sets new standards in terms of flexibility, ease of installation and economy.

In the Kalzip FC façade system, an extremely variable and at the same time easy to install building product is available to architects and planners for the implementation of new building

and renovation projects. The restrained, smooth surface of the aluminium panels conveys generosity and clarity. Within the variety of colour and form of common architecture the Kalzip FC façade system sets pleasantly restrained counterpoints and emphasises the formal aesthetics of the building.

Apart from the advantages in terms of materials, this system focuses on the flexible, patent-pending Vario system

installation. The functionality of the rainscreen metal façade, combined with the optimised, time-saving installation process, makes the Kalzip FC façade system a flexibly usable, highly economical building product.



# FC façade system – simple, flexible and economical

## New buildings and renovation

Due to the many different application possibilities with a simple construction and an outstanding price-performance ratio, the rainscreen and rear-ventilated FC façade is the best façade construction in terms of building physics.

It offers the greatest possible thermal protection, the aluminium material protects the building reliably and sustainably against the influences of the weather and gives the building its unmistakable character.

The rear ventilation regulates the moisture balance, prevents the accumulation of heat and protects against moisture damage.

This simple and sustainable façade concept, which was also developed with regard to recycling, is in many regards the solution for:

### New buildings

In the construction of new buildings the system captivates in particular by its uniqueness in the combinability of colours and panel widths. To this end various grid sizes of modular click rails are available for the sub-construction.

### Energetic façade renovation

For the renovation of existing building fabric the energy balance of a structure can be adapted to the currently valid and demanded energy standard with simple and low planning expenditure. CO<sub>2</sub> emissions are thus drastically reduced and the room climate is improved.

Due to the simplified construction the adjustment is carried out exclusively via the sub-construction.

The Battenberg comprehensive school before (left) and after (right) renovation  
**Battenberg (D)**

before



after



# The flexible ventilated facade system in aluminium with freely selectable installation direction and simple panel replacement

## Well-thought-out and leading installation technology

- Time-saving installation by clicking-in the system components – hence particularly economical
- Freely selectable installation direction from top to bottom or from bottom to top as well as transversely – independent of adjacent panels.

The advantage: The installation process follows the construction progress; connections and fitting parts can be installed later – hence, it is possible to omit complete façade fields in the traffic area until the completion of the exterior installations.

- Simply clicking of the accessories for fixed point, flashing support etc. into the modular click rail
- Suitable for laying on all sub-constructions – hence always the best solution in terms of economy and building physics

## Replacement instead of complete dismantling

- Simple and fast replacement of damaged panels with the FC toolkit
- Without time-consuming and expensive dismantling of complete façade areas
- Safeguarding of the visual appearance of the façade at all times

## High degree of design freedom for an expressive character

- Flat geometrical appearance with delicate joint pattern
- Multi-directional installation offers architects and planners variable design options
- Optimised manufacturing tolerances by further development of roll-forming technology
- Maximum design freedom thanks to large number of cover widths

- Accentuation of the metallic building envelope by expressive colours and surfaces
- All panels as standard with edge return without surcharge

## For sustainable and economic planning

- Reduced use of materials thanks to optimised panel geometry
- Cost-saving replacement of individual panels where necessary – a plus for the building insurance

Heinrich Meier GmbH Mühlacker  
Mühlacker (D)  
Architect: INEXarchitektur



# Packaging and dimensions

## General information

### Panel widths

Profil type:	Kalzip FC 30/250	Kalzip FC 30/300	Kalzip FC 30/350	Kalzip FC 30/400	Kalzip FC 30/450	Kalzip FC 30/500
<b>Profile thickness</b>	1.0 mm 1.2 mm	1.0 mm 1.2 mm	1.0 mm 1.2 mm	1.0 mm 1.2 mm	- 1.2 mm	- 1.2 mm
<b>Micro-ribbed</b>	no	no	no	yes	no	no

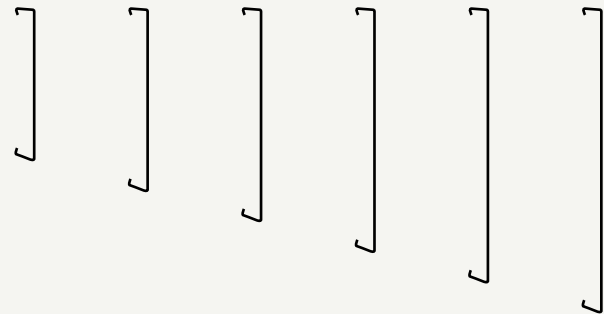

### Profile example

Kalzip FC with edge return



Kalzip FC without edge return



### Transition panels

For profile type:	Kalzip FC 30/250	Kalzip FC 30/300	Kalzip FC 30/350	Kalzip FC 30/400	Kalzip FC 30/450	Kalzip FC 30/500
<b>Blade length</b>	280 mm	330 mm	380 mm	430 mm	480 mm	530 mm

Transition panels, upper blade (left) lower blade (right)



### Corner panels

Corner panels can be manufactured as internal and external corners with different angles.

#### Specification

Blade 1: min. 150 mm/max. 1.000 mm  
Blade 2: min. 300 mm/max. 2.000 mm

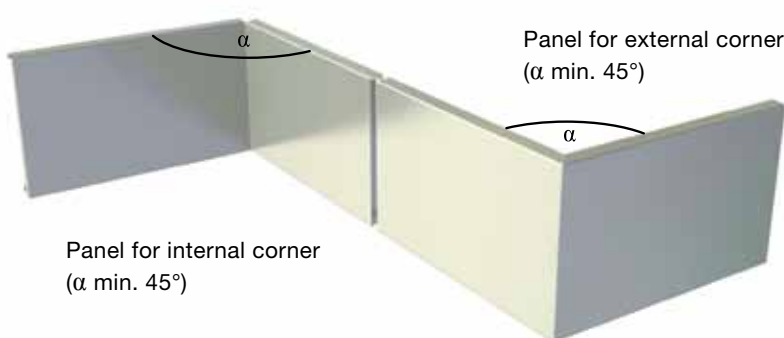

### Edge return

FC panels are supplied as standard with edge returns on both sides without surcharge.

Panels can also be manufactured without edge return on enquiry.





## Perforated panels

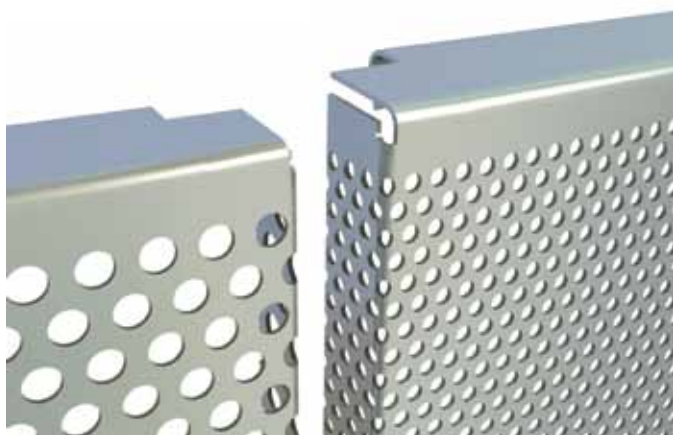

RV 6-8

Hole pattern:  
min. 45 % / max. 48 %  
depending on panel width  
Hole diameter: 6 mm

RV 3-5

Hole pattern:  
min. 29 % / max. 31 %  
depending on panel width  
Hole diameter: 3 mm

## Micro-ribbed panel

Kalzip FC 30/400 with edge  
return and micro-profiling

Start of micro-profiling:  
20 mm from the end of the  
panel



## Technical data

### Surfaces

- Standard colours RAL 9006 and 9007 for material thickness 1.0 mm
  - Further RAL, NCS and special colours on enquiry
  - Anti-graffiti coating on enquiry
- Notice: all surfaces are delivered as standard with a protective film.

### Materials

EN AW-3004, EN AW-3005 or EN AW-6025

### Dimensions

Length: min. 400 mm / max. 8,000 mm  
other profile lengths on enquiry

### Load-bearing capacity values

Load-bearing capacity values are based on Eurocode 9 and DIN 18807 in accordance with building authority approval no. Z-14.1-581 issued by the German Institute of Building Technology

### Tolerances

Sheet length according to Kalzip works standard

L 0,4 – 4,00 m	+2/-2 mm*
L > 4,00 – 8,00 m	+3/-3 mm*

Perpendicularity according to  
DIN EN 508-2

$u \leq 0.5 \%$  of the nominal width

### Transverse curvature $f_q$

according to EPAQ – European Quality Assurance Ass. for panels and profiles  
outwards (+0,02 \* panel width  $\leq 10$  mm)  
inwards (-0,01 \* panel width  $< 10$  mm)

\* Temperature information: measured at 20 °C

# Penetration-free fastening to modular rail

## NE modular click rail (structural ineffective)

The NE modular click rail is a non-load-bearing rail, which rests fully on a sub-construction and must be fixed at each snap-in position. The geometry corresponds to the mono-click bracket.

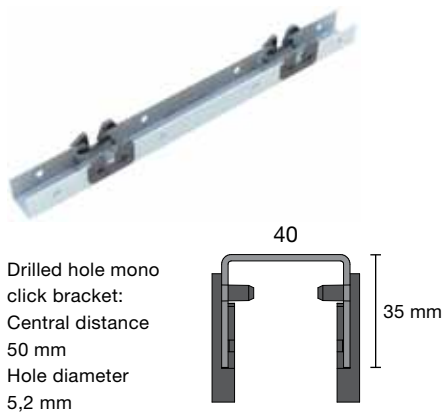

## SE modular click rail (structural effective)

The SE modular click rail is a self-supporting rail that can be used as statically load-bearing profile and can thus be fastened to a sub-construction independent of the snap-in position.

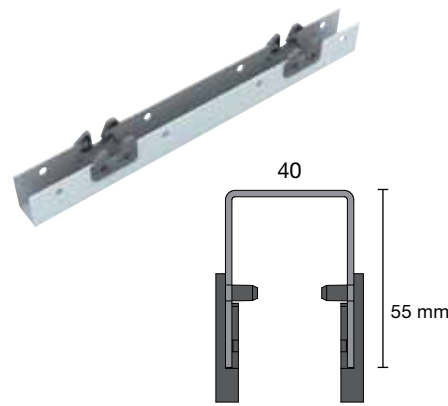

## SEL modular click rail (structural effective)

The SEL modular click rail is also a load-bearing rail and can be fastened directly to L wall holders thanks to the 50 mm long blade. A further continuous profile is not necessary.

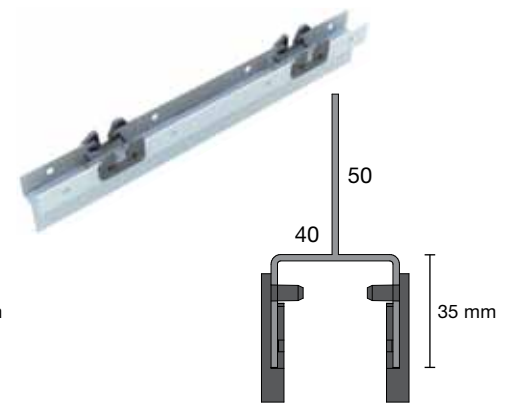

## Standard lengths

### Modular click rails (NE, SE, SEL)

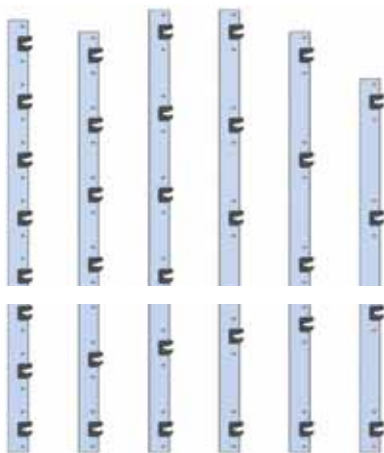

Type	250	300	350	400	450	500
Length in mm	2.950	2.900	3.000	3.000	2.900	2.700
Number of hook-in points	12	10	9	8	7	6

## Mono-click bracket

The mono-click bracket is used in particular for façade areas with changing panel widths or with complex connection details. It must always be fastened with two screws or rivets.

## Plastic Inlay

The plastic inlays are provided with a help line, which ensures the simple and accurate placement of the modular click rails.

**Mono-click bracket with plastic inlay**  
Length: 75 mm  
Drilled hole:  
central distance: 50 mm  
hole diameter: 5,2 mm

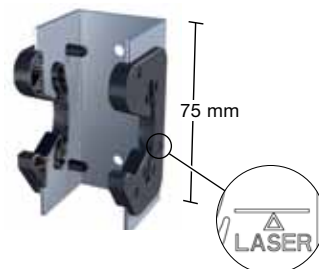

## Setting out tool

The modular click rails belonging to the system are supplied in maximum lengths of approx. 3 m. With the aid of the setting out tool, modular click rails to be mounted above one another can be adjusted and mounted to precisely fit the installation width of the FC panels with no additional measurement. The tool can be easily adjusted to the necessary standard installation width.





## Well-thought-out system accessories for a perfect result

### Fixed point clamp

In order to guarantee a uniform vertical joint pattern, each FC panel must be fixed in its defined position by a fixed point clamp belonging to the system. After the installation and alignment of the panel, the fixed point clamp can be loosened and fixed again, if necessary through the horizontal panel joint.

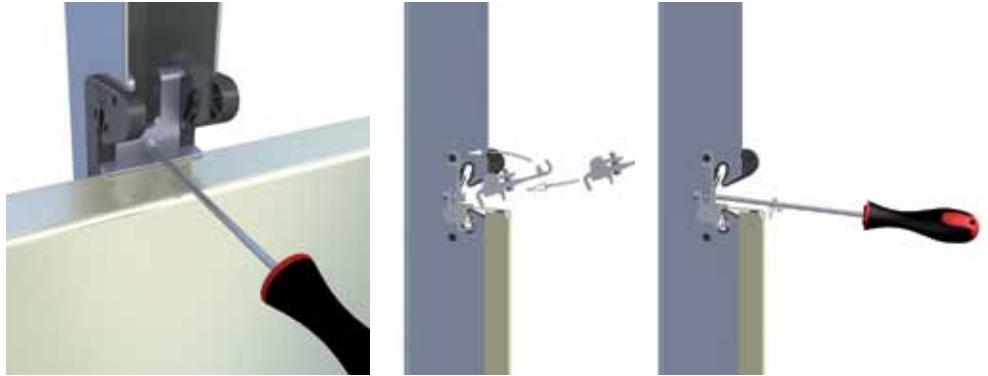

### Guidance snapper

The guidance snappers ensure a constant gap between the panels and in this way guarantee an even joint pattern. Use of the guidance snapper is absolutely necessary for very short panels and corner panels. Information can be found in the installation guidelines.



### Flashing support

A flashing support, which can be snapped onto the modular rail, is available for the simple and quick fastening of flashing (pilaster strips, corner, reveal and connection profiles). The holders engage in the holes provided and offer an even surface for the acceptance of the flashing without further adjustment.

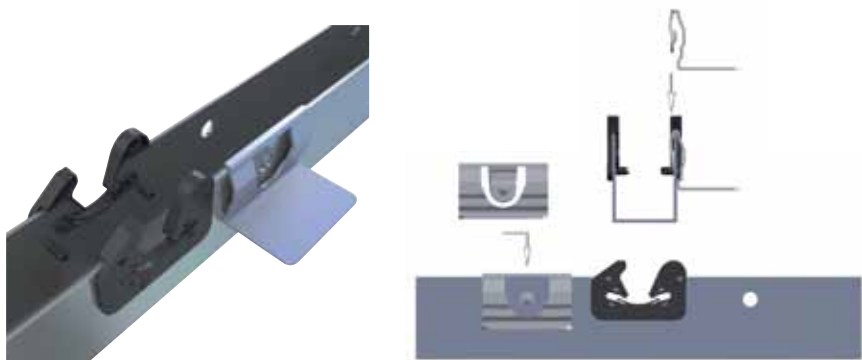

Number and arrangement when fastening pilaster strips: approx 1.5-off per m (offset arrangement)

# The system in detail

## Kalzip FC façade system – components

### Panels

#### Delivery options

- 1 FC panel
- 2 FC corner panel
- 3 Micro-profiled surface (FC 30/400 only)
- 4 Perforation Rv 3-5
- 5 Perforation Rv 6-8
- 6 FC panel luminaire

### System sub-construction

#### Variants

- 7 Mono click bracket
- 8 SEL modular click rail
- 9 NE modular click rail
- 10 SE modular click rail

### System accessories

#### Parts and components

- 11 Fixing point clamp
- 12 Guidance snapper
- 13 Flashing support
- 14 Plastic inlays
- 15 Setting out tool
- 16 FC Tool Kit
- 17 Plastic wedges



System depth with mono-click bracket, NE and SEL modular click rail



System depth with SE modular click rail



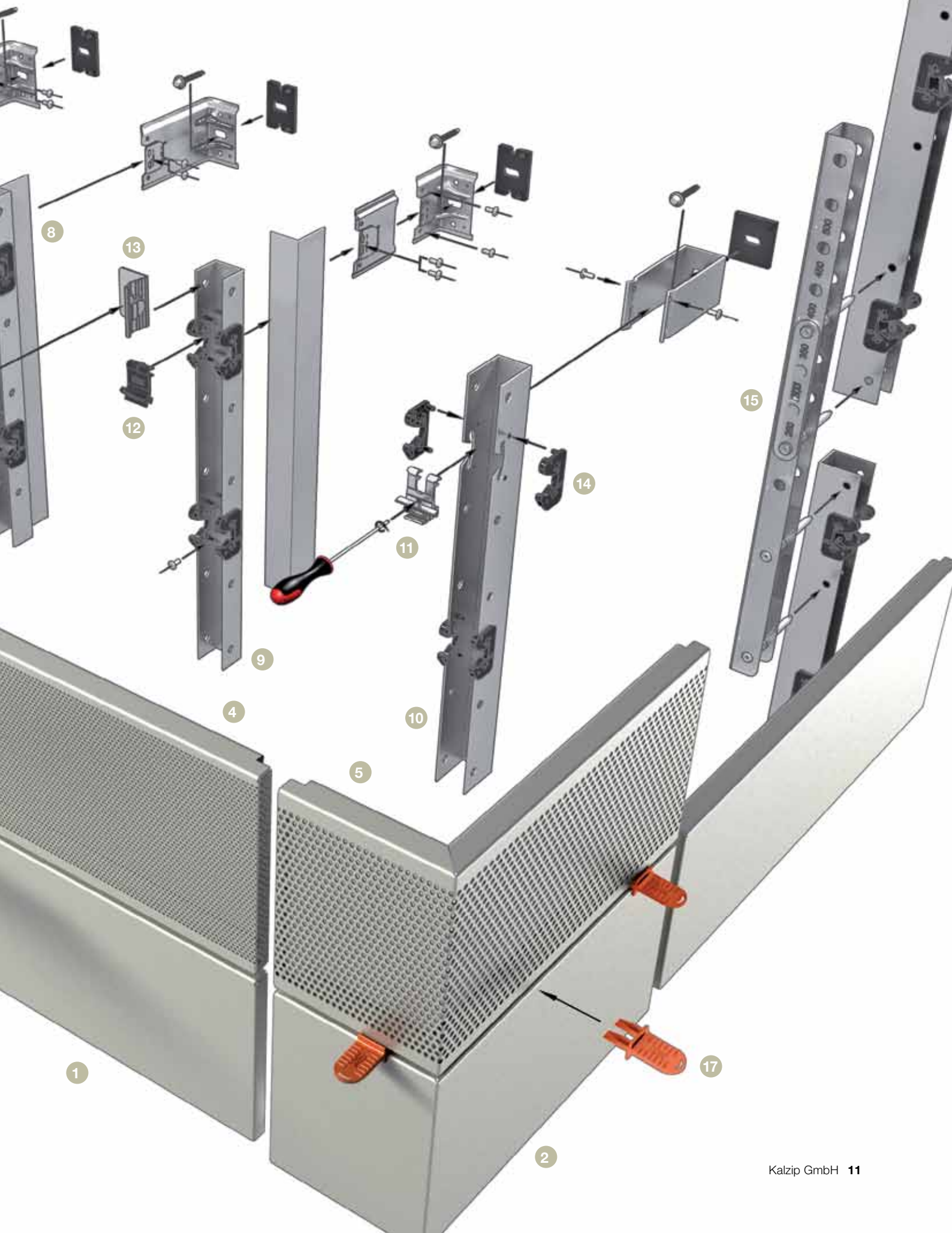



## Sub-constructions

### Mono-click bracket on vertical sub-construction

This version offers high flexibility for variable installation widths and in particular in joint areas (e.g. windows, openings, upper and lower junctions and terminations). The vertical L-rail is fastened with wall brackets to the support structure. The rail can be supplied pre-punched in a system pattern.

### NE modular click rail on a vertical sub-construction

The NE modular click rail is fastened to vertical support profiles. Alignment takes place in two steps with this system. A flat plane is created with the support profile; the modular rail then only needs to be adjusted in height. This guarantees precise alignment of the complete system.

### SEL 40 modular click rail on individual wall brackets

The SEL 40 modular click rail is a combination of support rail and modular rail. In conjunction with wall brackets, it can be used directly as a complete sub-construction. Since this system consists of only two components, it is a very economical system in terms of both material usage and installation times.





### SE modular click rail on U wall bracket

This system consists of a statically supporting modular click rail and U-profile wall brackets. Since this system consists of only two components, it is a very economical system in terms of both material usage and installation times. The alignment and adjustment of the rail should be carried out by experienced fitters.



### SE modular click rail on a horizontal sub-construction

Due to structural conditions (e.g. façade areas between ribbon glazings), it can be more economical to use a horizontal sub-construction. In conjunction with the supporting SE modular click rail, an economical system is produced that is simple to adjust.



### SE modular click rail on a structural cassette

The supporting SE modular click rail can also be used on steel cassettes. The rails are spaced on the one hand according to the permissible support width of the FC panels and on the other in accordance with the requirements for the steel cassettes. Vertical loads must be absorbed by means of suitable measures. The steel cassettes must be installed flat. Flashing is usually necessary for distance compensation.



# Structure of the FC façade system

## Design variants



**A** Narrow flashing



**B** Wide flashing



**C** No flashing



**D** Overlapping flashing

## Details

Number	Description
101	Pilaster strip
102, 103	External corner 90°/not angular
104, 105	Internal corner 90°/not angular
106	Window sill

Number	Description
107	Door / gate / window reveal
108	Door /gate / window lintel
109	Base
110	Parapet

## Detail numbers

The FC façade system can be used in principle with all existing support structures and wall constructions.

In order to simplify planning, 10 standard details in 4 different sub-construction variants have been developed for 6 different system solutions as examples.

These are available as pdf or dwg files in the downloads section at [www.kalzip.com](http://www.kalzip.com).

### Selection takes place according to the following procedure

1. Selection of the suitable sub-construction (p. 12/13)
2. Selection of the design variant
3. Selection of the required detail

### Example

SE modular click rail on horizontal sub-construction = 5 (see page 13)

Width of flashing = B

Detail of window sill = 106

Detail no. 5 - B - 106

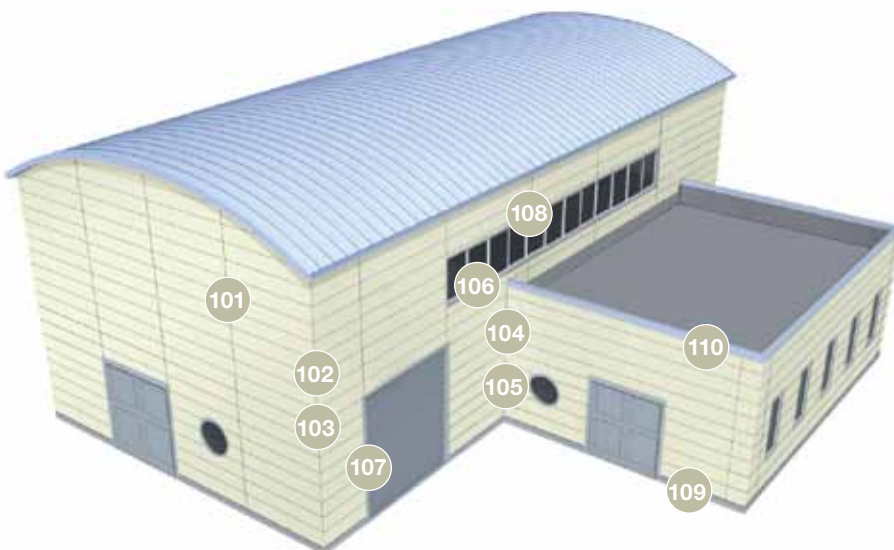

## Bi-directional panel installation

### Installation from bottom to top

- Step 1** Hook in panel
- Step 2** Click in panel
- Step 3** Click in fixed point clamp, adjust panel, tighten fixed point clamp.
- Step 4** Install next panel

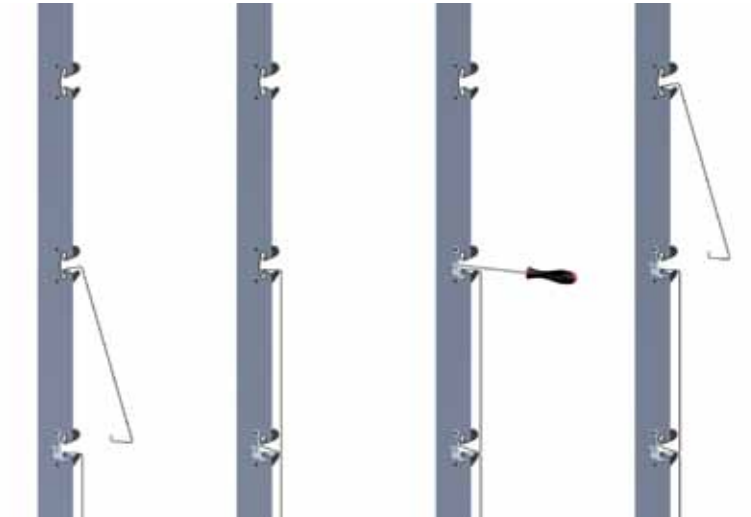

### Installation from top to bottom

- Step 1** Hook in panels
- Step 2 and 3** The upper panel must be removed a little from the front in order to install the fixed point clamp. Click in fixed point clamps, adjust panels, tighten fixed point clamps
- Step 4** Click in panels

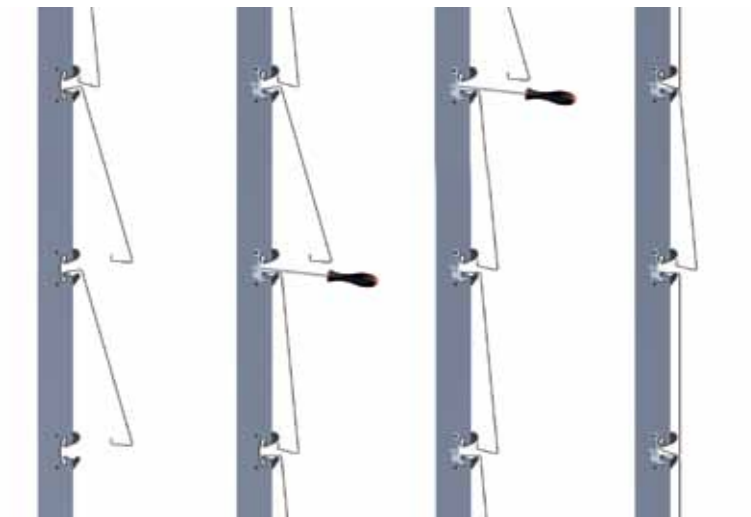

### In the middle of the area

- Step 1** Unhook the panel above the panel to be installed.
- Step 2** Hook in panel
- Step 3** Click in fixed point clamp, adjust panel, tighten fixed point clamp.
- Step 4** Click in panel

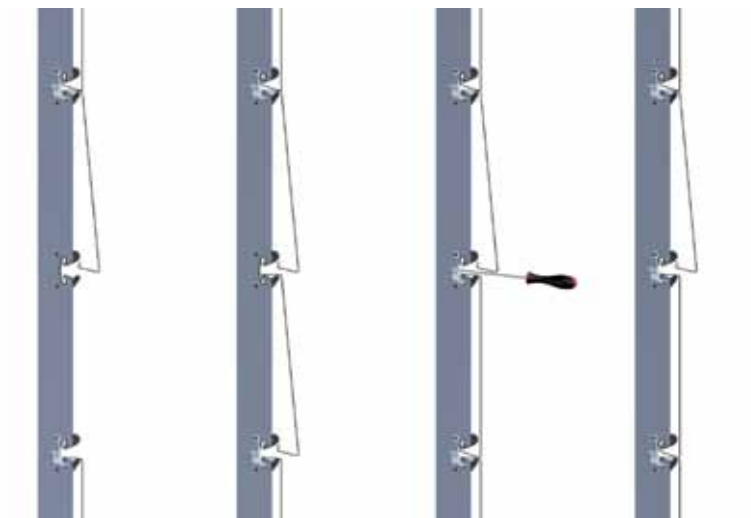

## Dismounting of panels

In case of damage to the wall the FC façade allows the replacement of individual panels without having to dismantle the entire wall cladding. A panel can be dismantled quickly and simply using

the specially developed tools from the Kalzip FC tool kit. The tool is inserted into the joint, pushed up to the first modular rail and the panel is then levered out.

This process is repeated on each rail. More detailed information can be found in the FC installation guideline.

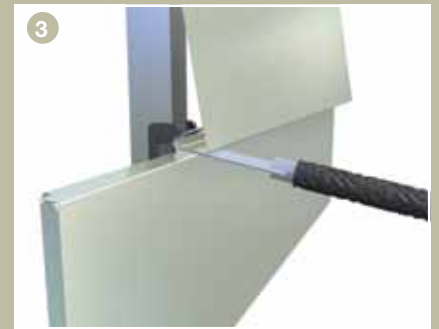



# 5 reasons to plan with Kalzip FC



## 1 Innovative click system

With the FC façade system the entire alignment of the façade takes place in the sub-construction. The façade panels then only need to be hooked in and clicked in and their position secured with the fixed point clamp.

## 2 Variable installation

In areas where the FC panels cannot be installed directly due to scaffolding anchors, missing panels or other reasons, they can be installed later with no additional expenditure. Building progress is not hindered and additional costs due to longer scaffolding times are avoided.

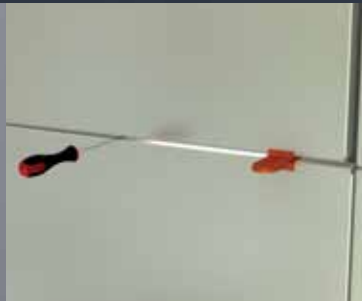

## 3 Easy to install

If the vertical joint pattern does not meet the requirements of the building owner or the architect after completion of the work, the panels can be subsequently adjusted in place (through the joint).

## 4 Flexible system

Different panel widths, edged special panels or special joint panels can be integrated into the system and require no separate sub-constructions or fasteners. That makes the FC façade system particularly flexible for planners and contractors.



## 5 Simple to dismantle

A special feature is the possibility to remove and reinstall individual FC panels without destruction and without having to dismantle the entire façade area. This also allows elements to be integrated that have to be serviced from time to time.

## General instructions

### Sub-construction

Two-part adjustable sub-constructions made of aluminium are recommended. Depending on the selected FC fastening (NE, SE, SEL modular click rails or mono-click brackets) the sub-construction is laid vertically or horizontally, or only individual wall holders are used (with the SEL modular click rail).

The distances, profile thicknesses and means of fastening are to be dimensioned according to the static requirements and professionally installed. The support width of the sub-construction for the mounting of the modular click rails or mono-click brackets must be at least 40 mm.

The sub-construction is to be aligned flush before commencing with the installation.

### Thermal insulating materials

With rainscreen, rear-ventilated façades, WAB (exterior insulation of walls) can be installed behind the ventilation in accordance with the necessary requirements. In principle the insulating material should have water-repellent properties according to DIN 18165.

In accordance with applicable building legislation, only thermal insulation materials which are approved for this application and which are monitored and fulfil the approval criteria of the hazardous materials regulations may be installed. The fire prevention of the individual regional building regulations must be adhered to; in principle non-flammable insulating materials must be used for multi-storey buildings according to DIN 4102-1.

The insulation causes heat to be stored in the interior structural elements, thus preventing large losses of heat in the cold seasons. In the warmer seasons, a large part of the heat radiated onto the cladding is reflected; a further portion is dissipated by the convective exchange of air in the rear ventilation space.

Spirit of Spice manufacture, **Willich (D)**  
Architect: Architekturbüro Dewey + Blohm-Schröder



## Rear ventilation

The FC façade system should be installed as a rear-ventilated façade system. In this rainscreen, rear-ventilated façade system the insulating and cladding components are structurally separated from one another. The façade cladding is the visible part and, in addition to providing the aesthetic appeal, it serves to protect the building from the influences of the weather – in particular the rain. The insulation fulfils the functions of protection against cold, heat and, if necessary, fire.

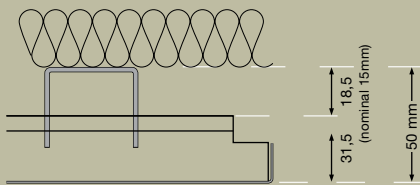

The rear ventilation space is located between these two components. It serves the removal of building or usage moisture and must be dimensioned accordingly. The insulation should ideally be located directly behind the modular rails. Use of the NE modular click rails produces a free cross-section of 18.5 mm.

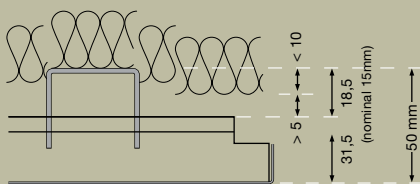

According to DIN a minimum distance of 5 mm must be kept in areas of foldbacks. If the possible tolerances (10 mm) in the installation of the thermal insulation are taken into account, this results in a theoretical value for the rear ventilation space of 15 mm. The façade can be closed off at the top or bottom with ventilation grilles; the free rear ventilation cross-sectional area

should be at least 200 cm<sup>2</sup>/m here. With the FC façade system the use of these ventilation grilles can be dispensed with if at least 3 FC panels (corresponding to 4 open joints) are installed above one another. This has been confirmed in investigations conducted by the Institute of Aerodynamics at the University of Applied Sciences in Aachen.

## Static calculation

The typical resistance values for the FC façade panels as well as the statically effective modular click rails (SE and SEL) can be found in the general building authority approval for the Kalzip FC façade system. These and the load/span tables for the FC panels are available for download at [www.kalzip.com](http://www.kalzip.com). A project-related, verifiable static calculation for the FC façade system can be prepared by the Application Technology Dept. in Koblenz if desired.

## Fire protection

In the context of the sample list 'Technical Building Regulations' in the appendix to DIN 18516-1, special fire protection precautions are to be observed for rear-ventilated external wall claddings with storey-spanning hollow spaces. This is subdivided into horizontal and vertical fire barriers (illustrated in excerpts below).

### Horizontal fire barriers

Fire barriers must be installed in every second storey in the rear ventilation gap between the wall and the cladding. These elements must be dimensionally stable for at least 30 minutes in case of fire. Sheet steel with a thickness of 1.0 mm can be used. The size of the openings in the horizontal fire barriers must be limited to a total of 100 cm<sup>2</sup>/running metre of wall.

The openings can be arranged as homogeneously distributed single openings or as a continuous gap.

In the case of external thermal insulation it is sufficient to install a horizontal fire barrier between the insulating material and the FC panels if the insulating material is dimensionally stable in case of fire and has a melting point of > 1000 °C. Horizontal fire barriers are not required:

- in case of external walls without openings
- if the arrangement of the windows makes the spread of fire in the rear ventilation gap impossible, e.g. in the case of continuous ribbon glazing or storey-spanning window elements
- if opening reveals are closed with dimensional stability for at least 30 minutes in case of fire (e.g. by sheet steel with a thickness of 1.0 mm mounted behind all round)

### Vertical fire barriers

These are exclusively necessary in the area of fire walls and must be at least as thick as the fire wall. The rear ventilation gap may not extend across the fire wall.

The insulation in this area must be made of a dimensionally stable insulating material (melting point >1000°C).

# www.kalzip.com

The data in this publication were provided to the best of our knowledge and belief.

They do not take into account any specific application. Claims cannot be derived from them. We reserve the right to make technically meaningful changes to designs and to our product range in the interests of our high quality standards and progress. Due to the dynamics of product developments and improvements, Kalzip's printed publications cannot always claim to be up to date. The currently valid version of each respective publication is available for download at [www.kalzip.com](http://www.kalzip.com).

Copyright 2013

Kalzip GmbH  
A Tata Steel Europe enterprise

## **Kalzip GmbH**

August-Horch-Str. 20-22

D-56070 Koblenz

Postfach 10 03 16

D-56033 Koblenz

Germany

T +49 (0) 2 61 - 98 34-0

F +49 (0) 2 61 - 98 34-100

E [germany@kalzip.com](mailto:germany@kalzip.com)

German