

# INSTALLATION

## TRIFAB® 451UT SCREW SPLINE ASSEMBLY

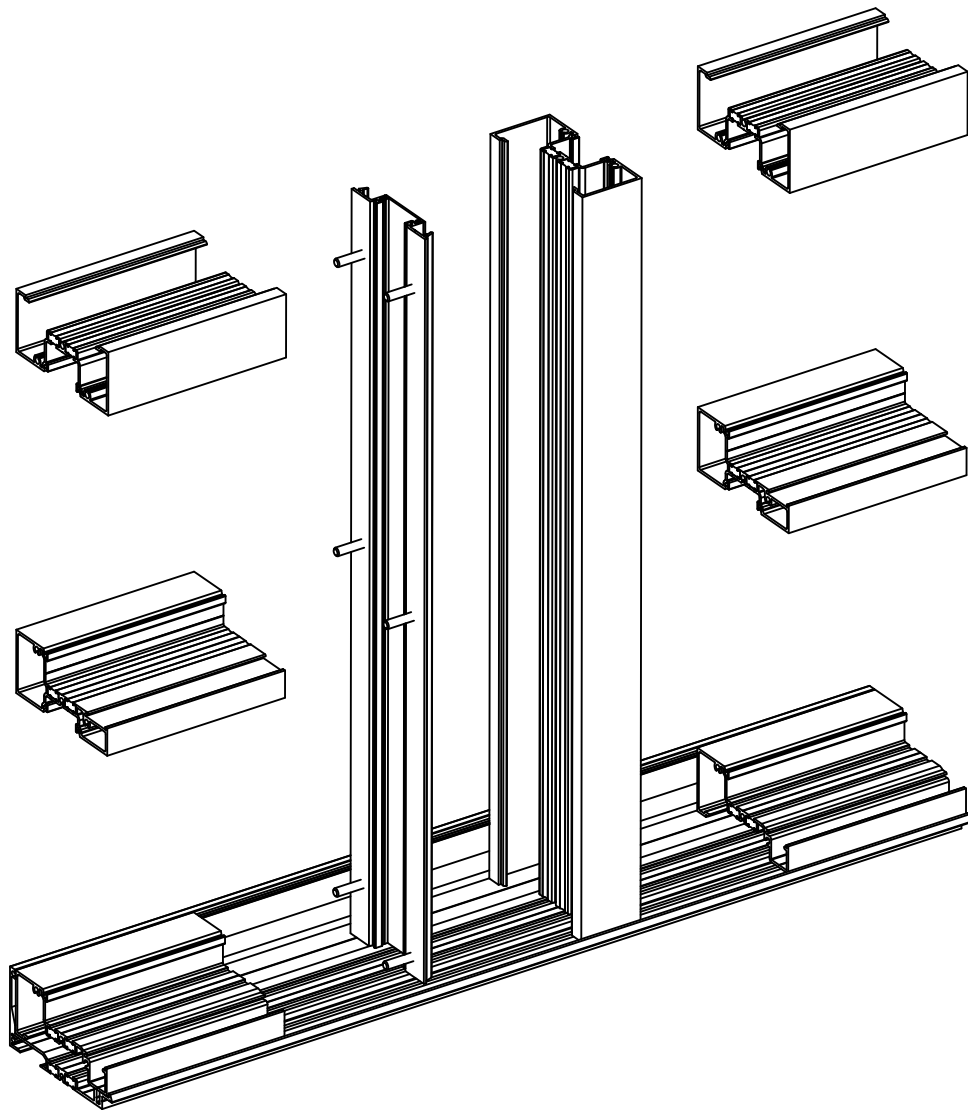

# INSTRUCTIONS

Laws and building and safety codes governing the design and use of glazed entrance, window, and curtain wall products vary widely. Kawneer does not control the selection of product configurations, operating hardware, or glazing materials, and assumes no responsibility therefor.

Kawneer reserves the right to change configuration without prior notice when deemed necessary for product improvement.

© Kawneer Company, Inc., 2010

These instructions show the general installation sequence and procedure for typical installation.  
They supplement the shop details and notations on installation and glazing.

<b>SECTION</b>	<b>PAGE</b>	
<b>I</b>	<b>3-4</b>	<b>GENERAL NOTES</b>
<b>II</b>	<b>5-6</b>	<b>TAKEOFF GUIDE</b>
<b>III</b>	<b>7</b>	<b>CUT FORMULAS</b>
<b>IV</b>	<b>8-10</b>	<b>PARTS IDENTIFICATION</b>
<b>V</b>	<b>11</b>	<b>BASIC FRAMING DETAILS</b>
<b>VI</b>	<b>12-13</b>	<b>FABRICATION</b>
<b>VII</b>	<b>14-18</b>	<b>INSTALLATION</b>
<b>IX</b>	<b>19-21</b>	<b>GLAZING</b>
<b>IIX</b>	<b>22-23</b>	<b>MISCELLANEOUS DETAILS</b>

Laws and building and safety codes governing the design and use of glazed entrance, window, and curtain wall products vary widely. Kawneer does not control the selection of product configurations, operating hardware, or glazing materials, and assumes no responsibility therefor.

Kawneer reserves the right to change configuration without prior notice when deemed necessary for product improvement.

© Kawneer Company, Inc., 2010

**HANDLING, STORING, AND PROTECTION OF ALUMINUM**

The material must be protected against damage. The following precautions are recommended to assure early acceptance of your products and workmanship.

- A. HANDLE CAREFULLY** - Don't drop from the truck. Stack with adequate separation so material will not rub together. Store off the ground. Protect against elements and other construction trades. Wear hand protection to prevent injury due to sharp edges of cut extrusions.
- B. KEEP MATERIAL AWAY FROM WATER, MUD AND SPRAY** - Prevent cement, plaster, or other materials from damaging the finish.
- C. PROTECT THE MATERIALS AFTER ERECTION** - Protect by wrapping with Kraft paper or by erecting Visqueen or canvas splatter screen. Cement, plaster, terrazzo, other alkaline solutions and acid based materials used to clean masonry are very harmful to the finish and should be removed with water and mild soap IMMEDIATELY.

**GENERAL INSTALLATION NOTES**

The following practices are recommended for all installations:

- A. CHECK SHOP DRAWINGS, INSTALLATION INSTRUCTIONS and GLAZING INSTRUCTIONS** to become thoroughly familiar with the project. The SHOP DRAWINGS take precedence and include specific details for the project. The INSTALLATION INSTRUCTIONS are of a general nature and cover most common conditions.
- B. All materials are to be INSTALLED PLUMB, LEVEL, AND TRUE.**
- C. All work should start from bench marks and/or column lines as established by the ARCHITECTURAL DRAWINGS and the GENERAL CONTRACTOR.** Check mullion spacing from both ends of masonry opening to prevent dimensional build-up of day light opening.
- D. Make certain that construction which will receive your materials is in accordance with the contract documents.** If not, notify the GENERAL CONTRACTOR IN WRITING and resolve differences before proceeding with your work.
- E. Isolate all aluminum to be placed directly in contact with uncured masonry or incompatible materials with a heavy coat of zinc chromate or bituminous paint.**
- F. Check all materials on arrival for quantity and be sure you have everything required to begin installation.**
- G. Sealants must be compatible with all materials with which they have contact, including other sealant surfaces.** Consult with sealant manufacturer for recommendations relative to joint size, shelf life, compatibility, priming, tooling, adhesion, etc.
- H. PERIMETER FASTENING** - "Fastening" means any method of securing one part to another or to adjacent materials. These instructions specify only those fasteners used within the system. Due to varying perimeter conditions and job performance requirements, anchor fasteners are not specified in these instructions. Refer to the Shop Drawings or consult a structural engineer for fastener type, sizing, and location.
- I. CHECK OPENINGS** - Make certain that the opening which will receive your materials is in accordance with the contract documents. If not, notify the General Contractor in writing and resolve differences before proceeding with your work.
- J. BUILDING CODES** - Glass and glazing codes governing the design and use of products vary widely. Kawneer does not control the selection of product configurations, operating hardware, or glazing materials, and assumes no responsibility for these design considerations. It is the responsibility of the owner, specifier, architect, general contractor and the installer to make these selections in strict conformance with all applicable codes.
- K. EXPANSION JOINTS** - Expansion joints and perimeter seals shown in these instructions and in the shop drawings are shown at normal size. Actual dimensions may vary due to perimeter conditions and /or difference in metal temperature between the time of fabrication and time of installation. For example, a 12 foot unrestrained length of aluminum extrusion can expand or contract 3/32" over a 50° F temperature change. Any movement potential should be accounted for at the time of installation.

- L. FIELD TESTING** - It is recommended that a Water Hose Test be conducted once a sufficient portion of the framing is installed, glazed and caulked to ensure proper installation. The Water Hose Test shall be conducted in accordance with AAMA 501.2. In addition, larger projects should have periodic Water Hose Tests as additional precautionary measures.
- M. GASKET INVENTORY ROTATION** - These high quality rubber extrusions are coated with silicone lubricant. Silicone will dry over time leaving a white "chalky" residue. Please rotate your stock "FIRST IN - FIRST OUT". If the rubber becomes dry, you may use water ONE TIME to reconstitute the silicone, after that, use a soap water solution.

Laws and building and safety codes governing the design and use of glazed entrance, window, and curtain wall products vary widely. Kawneer does not control the selection of product configurations, operating hardware, or glazing materials, and assumes no responsibility therefor.

Kawneer reserves the right to change configuration without prior notice when deemed necessary for product improvement.

© Kawneer Company, Inc., 2010

	CENTER IG STOPS UP	CENTER OG STOPS UP
<b>SCREW SPLINE FRAMING</b>		
Mullion and Filler	452T-CG-001 451T-CG-002	452T-CG-001 451T-CG-002
Jamb	452T-CG-001	452T-CG-001
Head	452T-CG-001	452T-CG-001
Horizontal	452T-CG-011	452T-CG-021
Sill	452T-CG-014	452T-CG-014
Glass Stop	451-CG-004	451-CG-004
Flashing	452T-CG-037	452T-CG-037
Spline Screw	028-856	028-856
End Dam	452CG315	452CG315
Drill Fixture	451-VG-201	451-VG-201
<b>ADJUSTABLE / BRAKE METAL CORNERS</b>		
Pivot Mullion Center		451T-CG-071
Pivot Mullion with Weathering		451T-CG-541
Mullion Half - Brake Metal Corners		452T-CG-010
<b>90° SNAP CORNERS</b>		
No Pocket Corner Half		450-017
One Pocket Corner Half		451T-CG-015
One Pocket Corner Half <i>(OPPOSITE OF 451-XX-015)</i>		451T-CG-035
Two Pocket Corner Half		451T-CG-016
<b>135° SNAP CORNERS</b>		
135° Mullion Center		451T-CG-034
135° Pocket Insert		451T-CG-028
<b>MISCELLANEOUS</b>		
Flat Filler		450-026
Caulking Backer		452-145
Snap-in Flat Pocket Filler		451-087
Vent Adaptor		469-407
1/4" Snap-in Infill Adaptor		451-VG-029
5/8" Snap-in Infill Adaptor		451-VG-030
<b>OPTIONAL MULLIONS &amp; STEEL REINFORCING</b>		
Medium Weight Mullion		452T-CG-012
Heavy Weight Mullion		452T-CG-013
2-1/4" Wide Mullion		452T-CG-112
Steel Reinforcing - <i>(2-1/4" Wide Mullion)</i>		450-110
Steel Reinforcing - <i>(Expansion Mullion)</i>		400-110
<b>Expansion Mullion</b>		
Expansion Mullion Male Half with Weathering		452T-CG-540
Expansion Mullion Female Half		452T-CG-010

Laws and building and safety codes governing the design and use of glazed entrance, window, and curtain wall products vary widely. Kawneer does not control the selection of product configurations, operating hardware, or glazing materials, and assumes no responsibility therefor.

Kawneer reserves the right to change configuration without prior notice when deemed necessary for product improvement.

© Kawneer Company, Inc. 2010

**CENTER SET  
INSIDE GLAZED OR OUTSIDE GLAZED**

**COMPENSATING RECEPTORS**

1-Piece Compensating Receptor with Weathering	451T-VG-571
2-Piece Compensating Receptor with Weathering	451T-VG-570
Standard Compensating Receptor Face with Weathering	451-VG-572
HW Compensating Receptor Face with Weathering	451-VG-573
Mullion End Load Clip for 1 or 2 Piece Compensating Receptors	451-VG-374

**OPTIONAL HORIZONTALS**

4-1/2" x 4-1/2" Horizontal	451T-CG-035 & 451T-CG-115
4-1/2" x 4-1/2" Sill Clip (2 PER DLO)	457-531
4-1/2" x 4-1/2" Shear Block Pkg	451-CG-617

**GLAZING MATERIALS**

Water Deflector	451-105
Sill Setting Block	027-073
Horizontal Setting Block	027-081
Side Block	480-520
Standard Push-on Gasket	027-074
Light Push-on Gasket	027-076
Heavy Push-on Gasket	027-077

**SPLICE SLEEVES**

Splice Sleeve - <i>Silicone Sheet</i>	127-178
---------------------------------------	---------

**ANCHORS**

Fastener / Shim Support - 3" LONG	452T-CG-126
-----------------------------------	-------------

Laws and building and safety codes governing the design and use of glazed entrance, window, and curtain wall products vary widely. Kawneer does not control the selection of product configurations, operating hardware, or glazing materials, and assumes no responsibility therefor.

Kawneer reserves the right to change configuration without prior notice when deemed necessary for product improvement.  
© Kawneer Company, Inc. 2010

**FRAMING MEMBER  
(CENTER OR FRONT OR BACK PLANE)**











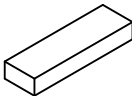
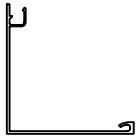





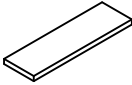

**CUT FORMULA**

MULLIONS AND MULLION FILLERS	FRAME HEIGHT - 1/2"
JAMBS	FRAME HEIGHT - 1/2"
CORNER MULLIONS	FRAME HEIGHT - 1/2"
CORNER PIVOT MULLIONS	FRAME HEIGHT - 1/2"
FLASHING	FRAME WIDTH PLUS 1/4" (SUBTRACT 1/2" FOR EACH SPLICE JOINT)
EXPANSION MULLIONS	FRAME HEIGHT - 1/2"
HEAD MEMBERS	DLO
HORIZONTALS & HORIZONTAL FILLERS	DLO
SILL MEMBERS	DLO
GLASS STOPS	DLO-1/16"
VERTICAL GLAZING ADAPTORS	PARTIAL LENGTHS = DLO + 1/2" FULL LENGTHS = SAME AS THE MULLION
HORIZONTAL GLAZING ADAPTORS	DLO
HEAD COMPENSATING RECEPTOR	FRAME WIDTH
JAMB COMPENSATING RECEPTOR	FRAME HEIGHT
VENT ADAPTORS (HORIZONTAL OR VERTICAL)	DLO

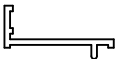
Laws and building and safety codes governing the design and use of glazed entrance, window, and curtain wall products vary widely. Kawneer does not control the selection of product configurations, operating hardware, or glazing materials, and assumes no responsibility therefor.

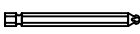
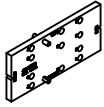
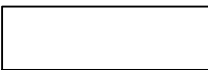
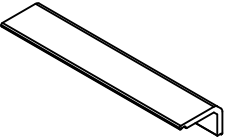
Kawneer reserves the right to change configuration without prior notice when deemed necessary for product improvement.

© Kawneer Company, Inc. 2010













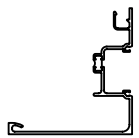
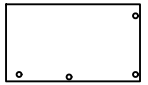
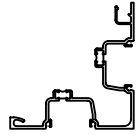
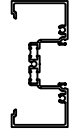

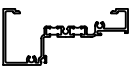

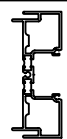
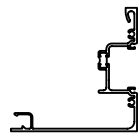
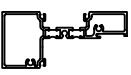
PART NO.	DESCRIPTION	ILLUSTRATION	PART NO.	DESCRIPTION	ILLUSTRATION
027-073	SILL SETTING BLOCK (451/451T)		450-017	90° NO POCKET CORNER HALF	
027-074	STANDARD PUSH ON GASKET		450-087	SNAP IN FLAT POCKET FILLER & VENT ADAPTER	
027-076	LIGHT PUSH ON GASKET		450-110	STEEL REINFORCING (450/451 CENTER)	
027-077	HEAVY PUSH ON GASKET		451-087	SNAP-IN FLAT POCKET FILLER	
027-081	HORIZONTAL SETTING BLOCK (451/451T)		451-105	WATER DEFLECTOR (451/451T)	
028-808	#8 x 1/2" PHTF SILL TO FLASHING AND END DAM SCREW		451-CG-004	GLASS STOP	
028-856	#12x1-1/8 PHTF TYPE "AB" (SPLINE SCREW)		451-VG-029	1/4" INFILL ADAPTER	
060-888	VENT ADAPTER FOR EQUAL LEG FRAMES		451-VG-030	5/8" INFILL ADAPTER	
063-040	BALL POINT BIT FOR 128-242		451-VG-201	DRILL FIXTURE SCREW-SPLINE (451/451T)	
127-178	SPLICE SLEEVE FOR 452T-CG-037 FLASHING		451-VG-374	REINFORCING CLIP FOR 451(T)-VG-570 & 571 COMPENSATING RECEPTORS	
128-242	OPTIONAL BALL POINT SPLINE SCREW #12x1 SOCKET HEAD		451-VG-572	COMPENSATING RECEPTOR FACE W/WEATHERING	
400-110	OPTIONAL STEEL REINFORCEMENT FOR CENTER EXPANSION MULLION		451-VG-573	TUBULAR COMPENSATING RECEPTOR FACE W/WEATHERING	

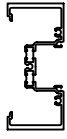
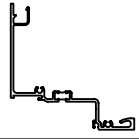
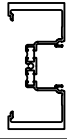
Laws and building and safety codes governing the design and use of glazed entrance, window, and curtain wall products vary widely. Kawneer does not control the selection of product configurations, operating hardware, or glazing materials, and assumes no responsibility therefor.

Kawneer reserves the right to change configuration without prior notice when deemed necessary for product improvement.

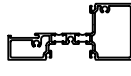
© Kawneer Company, Inc. 2010

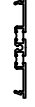

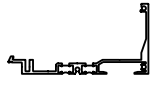





PART NO.	DESCRIPTION	ILLUSTRATION	PART NO.	DESCRIPTION	ILLUSTRATION
451T-CG-002	POCKET FILLER		452-145	SEALANT BACKER	
451T-CG-015	ONE POCKET CORNER HALF		452-CG-315	END DAM FOR 452T-CG-037	
451T-CG-016	TWO POCKET CORNER HALF		452T-CG-001	MULLION JAMB OG HEAD	
451T-CG-028	DEEP POCKET FILLER		452T-CG-003	IG HEAD	
451T-CG-034	135° CORNER MULLION		452T-CG-010	TUBULAR EXPANSION MULLION FEMALE HALF	
451T-CG-035	ONE POCKET CORNER HALF		452T-CG-011	INSIDE GLAZED HORIZONTAL	
451T-CG-071	0°-25° PIVOT MULLION (CENTER PLANE)		452T-CG-012	MEDIUM WEIGHT MULLION	
451T-CG-115	4-1/2" HORIZONTAL HALF		452T-CG-013	HEAVY WEIGHT MULLION	
451T-CG-541	0°-25° PIVOT MULLION W/WEATHERING		452T-CG-014	HP SILL	
451T-VG-570	COMPENSATING RECEPTOR W/WEATHERING		452T-CG-021	OUTSIDE GLAZED HORIZONTAL	
451T-VG-571	ONE PIECE COMPENSATING RECEPTOR W/WEATHERING		452T-CG-026	PERIMETER FILLER	
452-132	VENT ADAPTER BLACK PVC (451/451T)		452T-CG-037	HP SILL FLASHING	

Laws and building and safety codes governing the design and use of glazed entrance, window, and curtain wall products vary widely. Kawneer does not control the selection of product configurations, operating hardware, or glazing materials, and assumes no responsibility therefor.

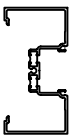
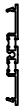
Kawneer reserves the right to change configuration without prior notice when deemed necessary for product improvement.

© Kawneer Company, Inc. 2010

PART NO.	DESCRIPTION	ILLUSTRATION	PART NO.	DESCRIPTION	ILLUSTRATION
452-132	VENT ADAPTER BLACK PVC				
452-145	SEALANT BACKER				
452T-CG-112	2 1/4" MULLION				
452T-CG-126	3" SHIM SUPPORT				
452T-CG-540	EXPANSION MULLION W/WEATHERING MALE HALF				
469-407	GLASSVENT POCKET FILLER				
480-520	SIDE BLOCK				

Laws and building and safety codes governing the design and use of glazed entrance, window, and curtain wall products vary widely. Kawneer does not control the selection of product configurations, operating hardware, or glazing materials, and assumes no responsibility therefor.

Kawneer reserves the right to change configuration without prior notice when deemed necessary for product improvement.  
© Kawneer Company, Inc. 2010

The Screw Spline System is a fabrication and erection method that permits the pre-assembly of single units in the shop or at the job site. These units are then erected by mating the male mullion half of one unit with the female half of the unit already installed.

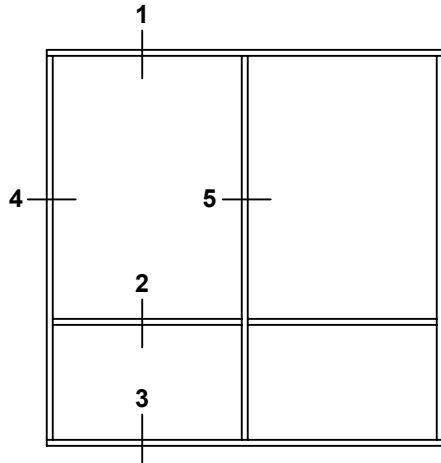

**NOTES:**  
 If opening is over 24' wide, a splice joint is required every 12'. (See splice joint procedure on page 16)

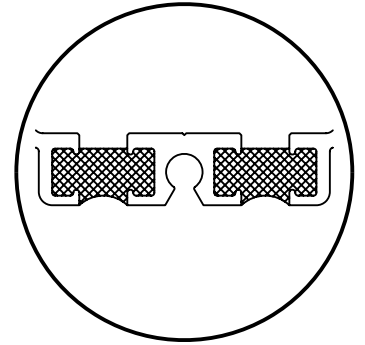

TRIFAB® 451UT  
THERMALLY BROKEN MEMBERS

ELEVATION IS NUMBER KEYED TO DETAILS

OUTSIDE GLAZED

INSIDE GLAZED

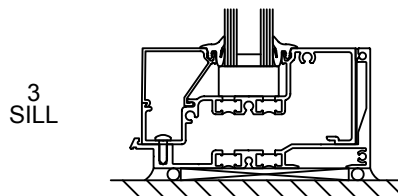
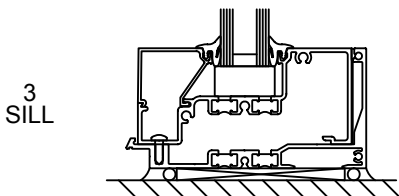
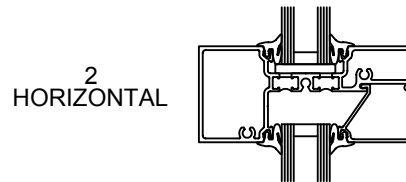
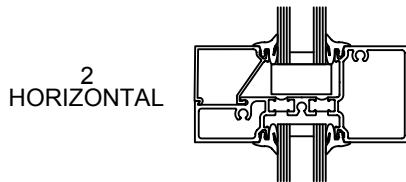
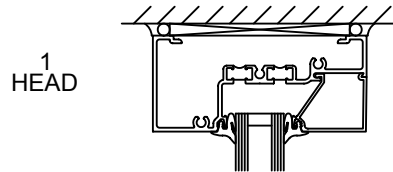
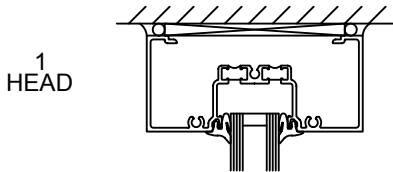
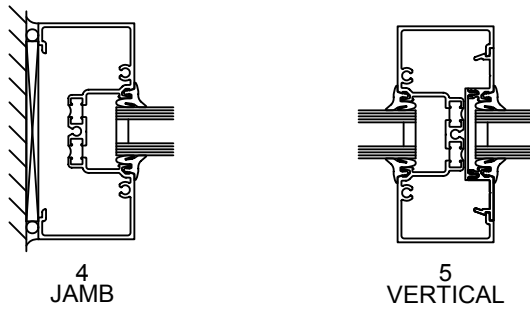

Laws and building and safety codes governing the design and use of glazed entrance, window, and curtain wall products vary widely. Kawneer does not control the selection of product configurations, operating hardware, or glazing materials, and assumes no responsibility therefor.

Kawneer reserves the right to change configuration without prior notice when deemed necessary for product improvement.

© Kawneer Company, Inc., 2010

**STEP A:** Measure the opening to determine length of vertical and horizontal framing members. Allow a minimum of 1/2" for flashing when measuring vertical lengths. Allow 1/4" minimum clearance at the head, sill, and each jamb to facilitate installation and provide space for caulking. If job conditions are uncertain, or masonry openings are irregular, allow extra clearance to accommodate construction tolerance.

**STEP B:** Cut vertical members to required length (Frame Height - 1/2"). At desired horizontal locations drill the proper holes in the vertical members for attachment of the spline screws, as shown below.

**TRIFAB 451UT OUTSIDE GLAZED**  
PLACE ONTO MULLION AS SHOWN BELOW

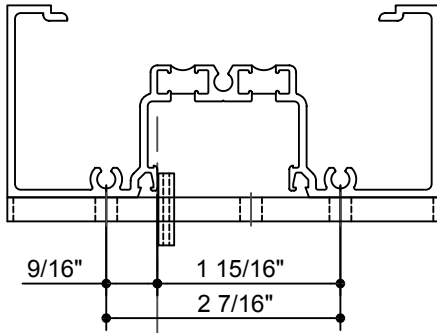

**TRIFAB 451UT INSIDE GLAZED**  
PLACE ONTO MULLION AS SHOWN BELOW

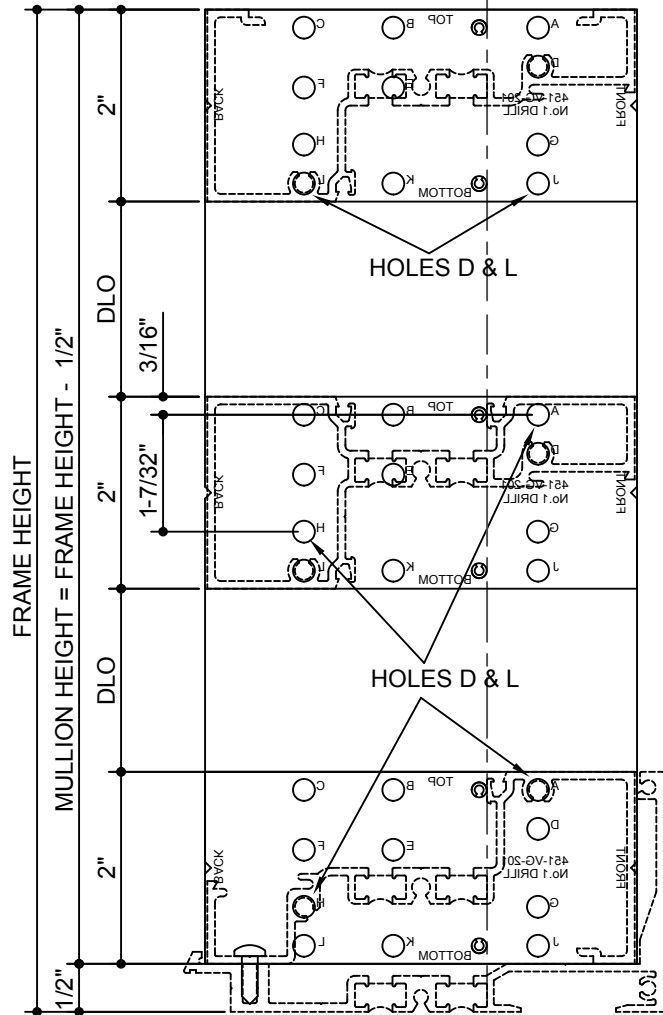
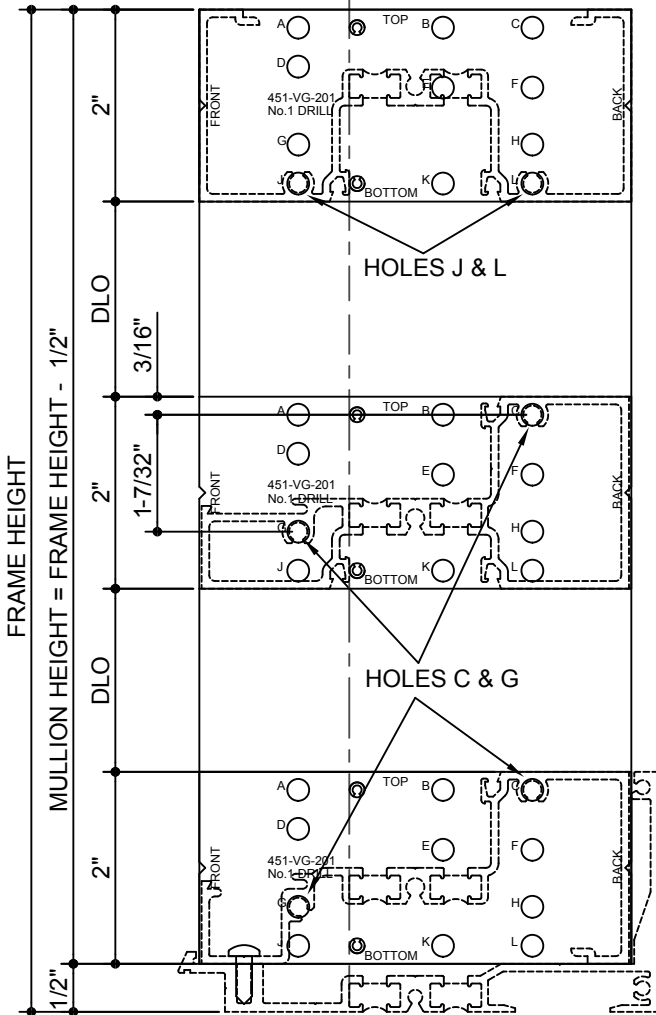
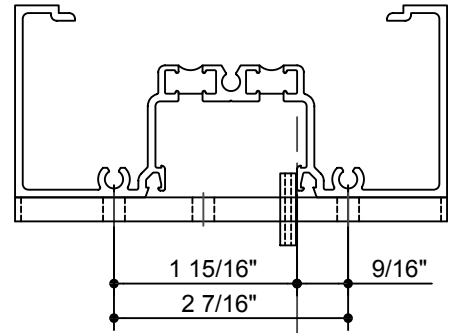

Measure the opening to determine length of vertical and horizontal framing members. Allow 1/4" minimum clearance at the head, sill, and each jamb to facilitate installation and provide space for caulking. If job conditions are uncertain, or masonry openings are irregular, allow extra clearance to accommodate construction tolerance.

- STEP A: Cut Sill Flashing to length.
- STEP B: Drill perimeter anchor holes through the flashing (DO NOT DRILL THROUGH THERMAL BREAKS). Anchor holes should be located within 6" of each end of the flashing and 12" O.C. between or as determined by structural calculations. (See Note 1)
- STEP C: Drill two 5/16" weep holes at 1/4 points of each D.L.O. in exterior face of sill flashing as shown below.
- STEP D: Apply sealant to ends of flashing. (Figure 3)
- STEP E: Attach end dams to flashing with four 028-808 (#8 x 1/2" PHTF) supplied screws, and seal over heads. Tool sealant along outside edges and inside corners between end dam and flashing.

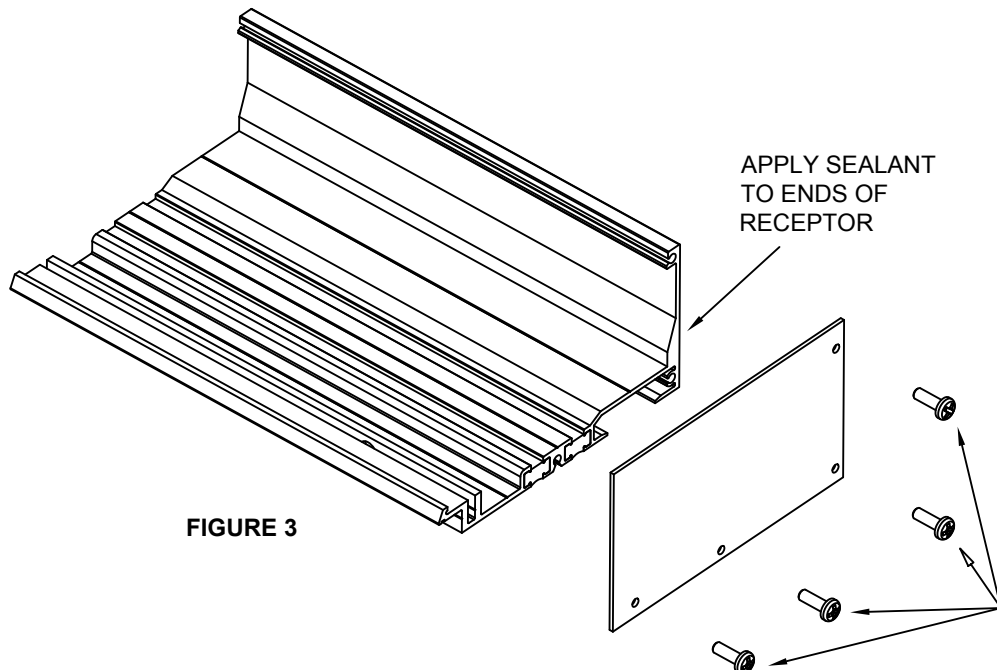

FIGURE 3

ATTACH END DAM TO RECEPTORS WITH SUPPLIED FASTENERS AND SEAL OVER FASTENER HEADS

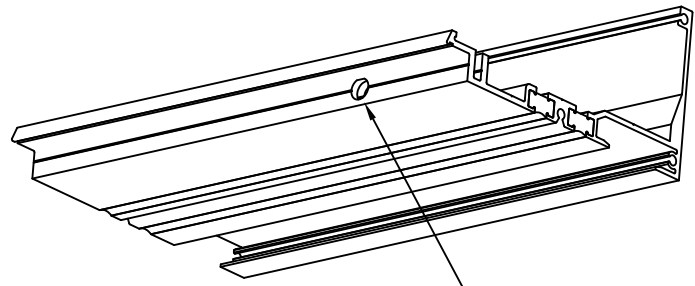

FIGURE 4

**NOTE:**

1. REFER TO SHOP DRAWINGS OR CONSULT ENGINEERING FOR PERIMETER FASTENER SIZE AND LOCATIONS.
2. IF OPENING IS OVER 24' WIDE, A SPLICE JOINT IS REQUIRED EVERY 12'. SEE SPLICE JOINT INSTALLATION ON PAGE 16.

Laws and building and safety codes governing the design and use of glazed entrance, window, and curtain wall products vary widely. Kawneer does not control the selection of product configurations, operating hardware, or glazing materials, and assumes no responsibility therefor.

Kawneer reserves the right to change configuration without prior notice when deemed necessary for product improvement.  
© Kawneer Company, Inc., 2009

STEP A: Cut horizontals to length (Daylight Opening) and apply sealant to the ends ensuring a good seal to the vertical member. (Glass stops should be D.L.O. - 1/16").

STEP B: Assemble the units using two (#12 x 1-1/8" P. H.Screws) at each joint as shown below. Be sure that each unit is fabricated with a male and female mullion half.

**NOTE:**

**EVERY UNIT MUST HAVE AT LEAST ONE DEEP VERTICAL POCKET.**

STEP C: When an entrance is required, Shear Block joinery must be used to attach horizontals to the immediate door frame. The other side of the sidelite will be fabricated for screw spline joinery as usual.

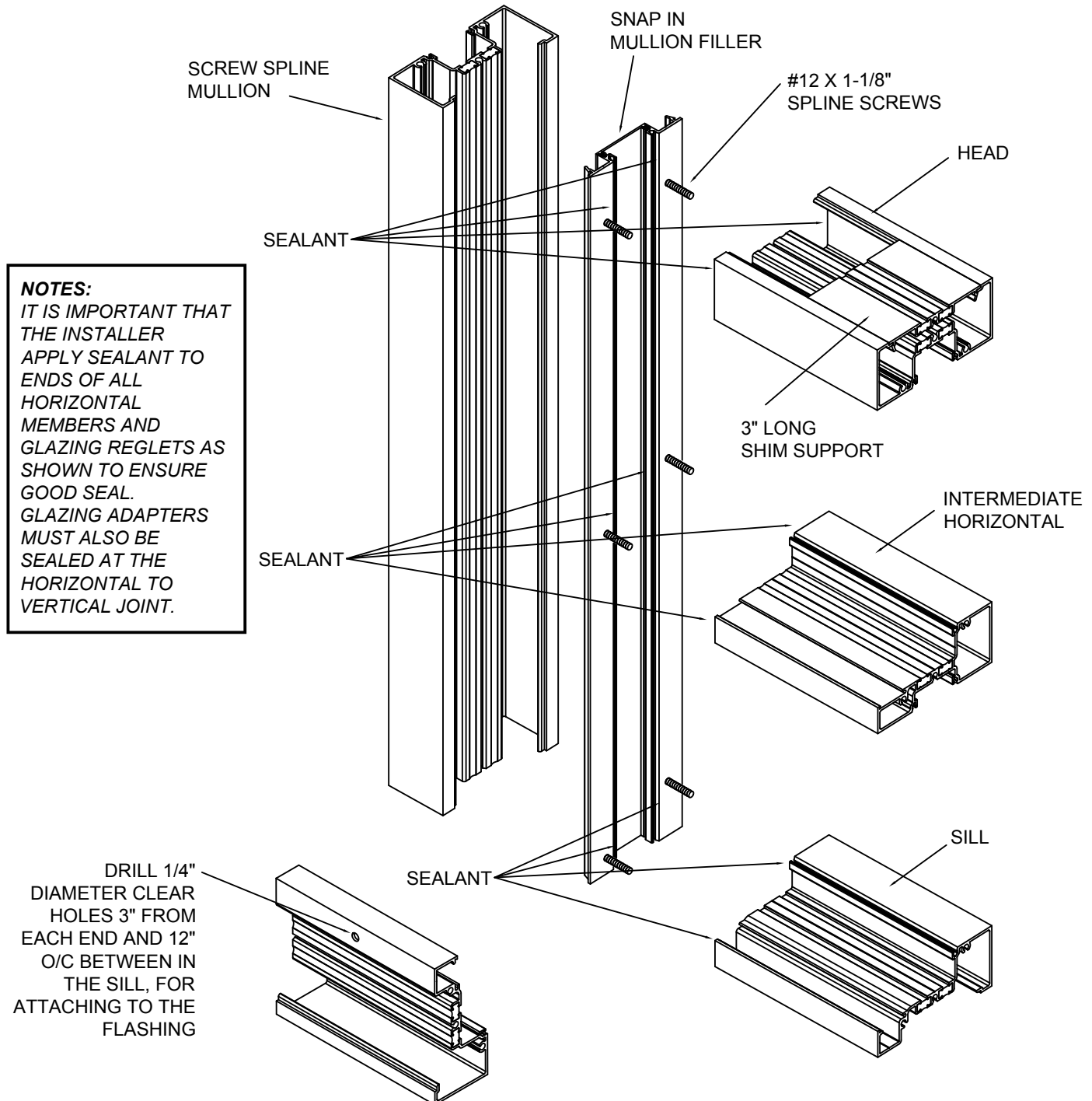

Laws and building and safety codes governing the design and use of glazed entrance, window, and curtain wall products vary widely. Kawneer does not control the selection of product configurations, operating hardware, or glazing materials, and assumes no responsibility therefor.

Kawneer reserves the right to change configuration without prior notice when deemed necessary for product improvement.

© Kawneer Company, Inc. 2010

**FLASHING INSTALLATION**

Install sill flashing level and true in opening. The sill flashing should be shimmed up a minimum of 1/4" as required at each fastener and under the location of each mullion to level flashing. Seal over all fasteners at the sill flashing.

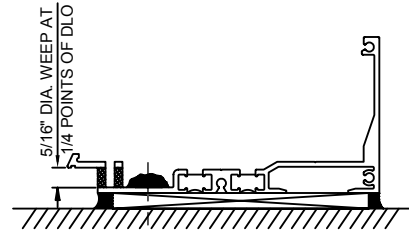

*Force sealant into hole for sill perimeter fastener. Coat fastener threads and shank with sealant prior to installing. Seal over heads of fasteners at sill.*

**FRAME INSTALLATION**

STEP 1: Apply sealant to the upstanding leg on the back of flashing, and apply sealant to front

STEP 2: Position the assembled frame into the opening to align with sill flashing. Seat frame tightly against back leg of flashing to ensure good seal. Install #8 x 1/2" PHTF fasteners into the front of the sill attaching it to the flashing.

STEP 3: Insert shims as needed at head and jambs, checking that the unit is level and plumb.

**NOTE:**

If heavy mullion or steel reinforcing is used, extra perimeter fasteners may be required to handle larger loads. Consult Area Application Engineering Department.

STEP 4: Caulk both interior and exterior at head, jambs and under sill flashing with a high quality sealant.

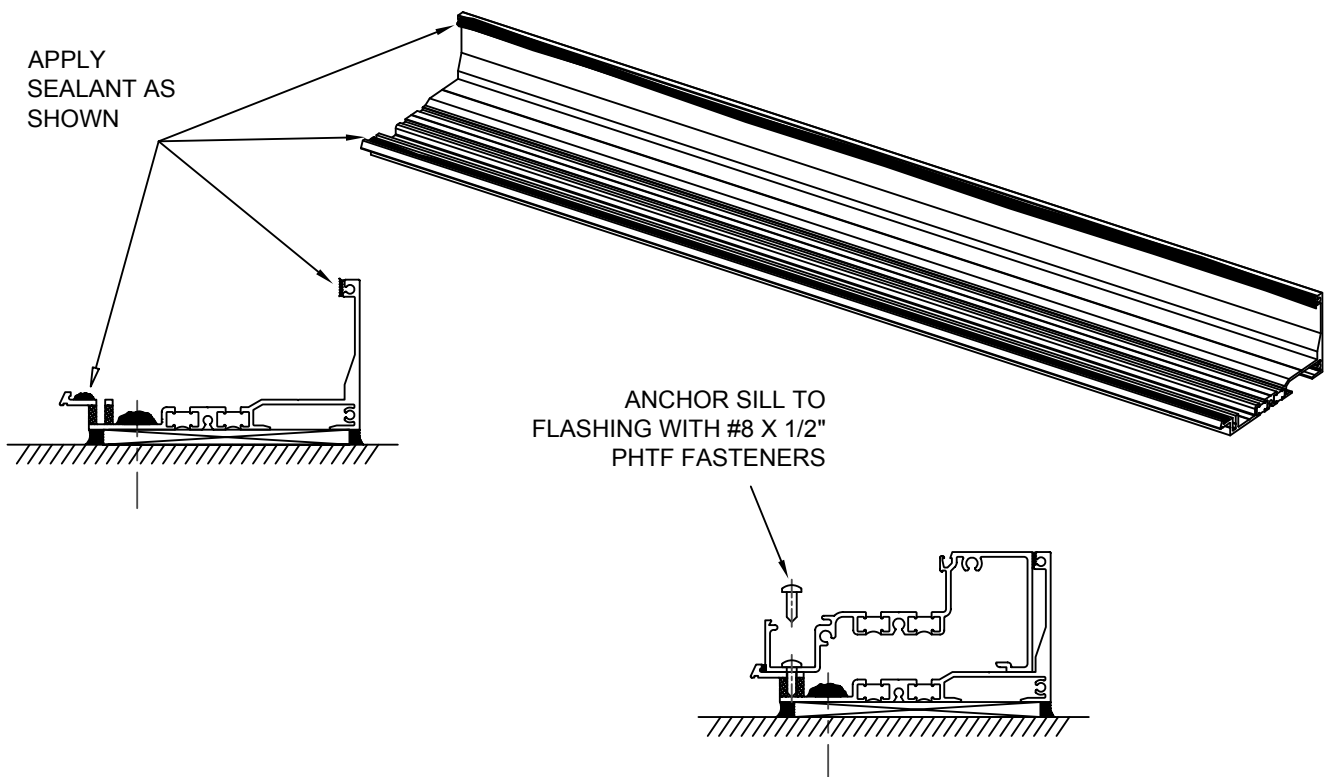

**SILL FLASHING**

Install flashing at the sill. It should be level, shimmed up a minimum of 1/4", and carefully sealed at both end dams as shown on Page 13. Seal over the heads of all perimeter anchor fasteners.

APPLY BEAD OF SILICONE SEALANT OVER BACKER ROD BETWEEN 1/2" JOINT IN FLASHING AND TOOL INTO JOINT

APPLY BEAD OF SILICONE SEALANT WITHIN A 1/2" OF SPLICE JOINT ON FLASHING

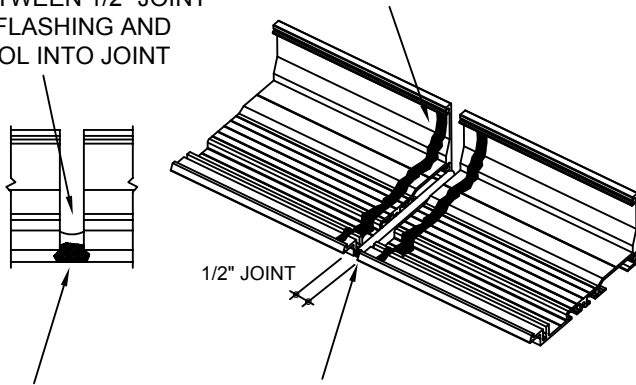

PLACE BACKER ROD BETWEEN SPLICE IN THE SHIM SPACE AND SEAL BETWEEN SPLICE WITH SILICONE

**FIGURE 1**

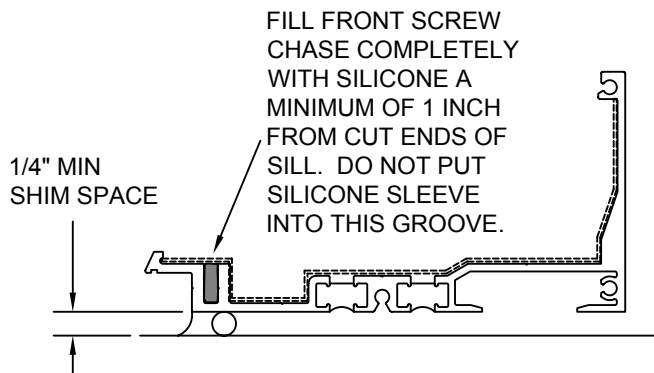

FILL FRONT SCREW CHASE COMPLETELY WITH SILICONE A MINIMUM OF 1 INCH FROM CUT ENDS OF SILL. DO NOT PUT SILICONE SLEEVE INTO THIS GROOVE.

1/4" MIN SHIM SPACE

**FIGURE 2**

USE PUTTY KNIFE TO FORM SILICONE SPLICE SLEEVE ALONG THE PROFILE OF THE FLASHING

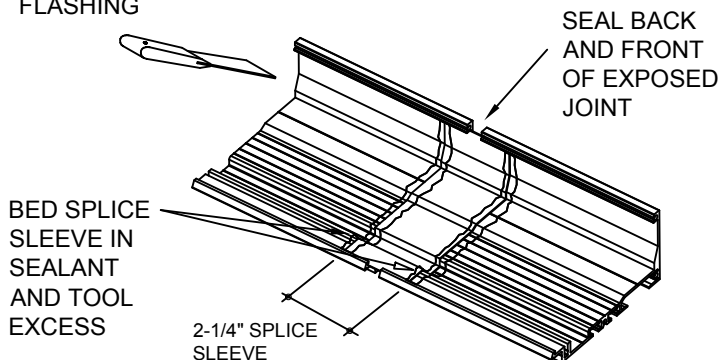

SEAL BACK AND FRONT OF EXPOSED JOINT

BED SPLICE SLEEVE IN SEALANT AND TOOL EXCESS

2-1/4" SPLICE SLEEVE

**FIGURE 3**

**NOTE:**

1) **SPLICES SHOULD BE INSTALLED EVERY 12' WHEN FLASHING IS OVER 24'. SPLICE SLEEVES ARE TO BE LOCATED AT THE CENTER OF A DLO.**

**DO NOT LOCATE SPLICE SLEEVES AT MULLIONS.**

2) **IF THERE IS AN ENTRANCE, THE ENTRANCE FRAME AND ATTACHED SIDELITE(S) SHOULD BE INSTALLED FIRST, BEING CAREFUL TO LOCATE THEM ACCURATELY IN THE OPENING. FASTEN THE ENTRANCE FRAME TO THE PERIMETER CONDITION AS NECESSARY USING THE REQUIRED PERIMETER FASTENERS.**

3) **SILICONE MUST BE TESTED AND APPROVED FOR COMPATIBILITY BY THE SEALANT MANUFACTURER.**

**PROCEDURE FOR INSTALLING SILICONE SPLICE SLEEVE (Follow silicone supplier recommendation for cleaning and priming the joint)**

1. Cut Silicone Splice Sleeve (127-178) to 7 inches long.
2. Clean splice area with solvent.  
*(For cold weather applications see note below.)*
3. Apply bead of silicone within 1/2" of the edge of the sill members on each side of the 1/2" joint. (Figure 1)
4. Fill front screw chase completely with silicone beyond splice a minimum of 1 inch from cut end of sill. (Figure 2)
5. Remove protective liner from Splice Sleeve.
6. Center the Splice Sleeve over the joint. Then, using a putty knife, form the Splice Sleeve along the profile of the flashing. (Figure 3)
7. Silicone will squeeze out from under the Splice Sleeve. Use putty knife to tool off excess silicone. There should not be excessive build up of sealant thickness at the front and back of the splice where the horizontal sits down on top of the splice. (Figure 3)
8. Seal back and front of exposed joint and marry into perimeter seals. Be sure to force sealant up under the Splice Sleeve in front. Seal the exposed joint. (Figure 3)

**COLD WEATHER NOTE:**

**FOR TEMPERATURES BELOW 40° THE FOLLOWING PRECAUTIONS SHOULD BE TAKEN. JUST PRIOR TO INSTALLING THE SILICONE SPLICE SLEEVE, WIPE RECEPTOR WITH A SOLVENT OR CLEANING SOLUTION RECOMMENDED BY THE SEALANT MANUFACTURER. THIS WILL REMOVE ANY CONDENSATION OR FROST THAT MAYBE PRESENT.**

**\*CAUTION:**

**CAREFULLY FOLLOW THE RECOMMENDATIONS CONTAINED IN THE MATERIAL SAFETY DATA SHEET PROVIDED BY THE SOLVENT/CLEANING SOLUTION MANUFACTURER REGARDING HEALTH AND FIRE/EXPLOSION RISKS.**



Install water deflectors on Intermediate Horizontals by removing the paper backing from the water deflectors. Install on a clean, dry surface centered in the glazing pocket and seal. (Figure 1) Be sure to extend Water Deflector past glass edge below. (Figure 2)

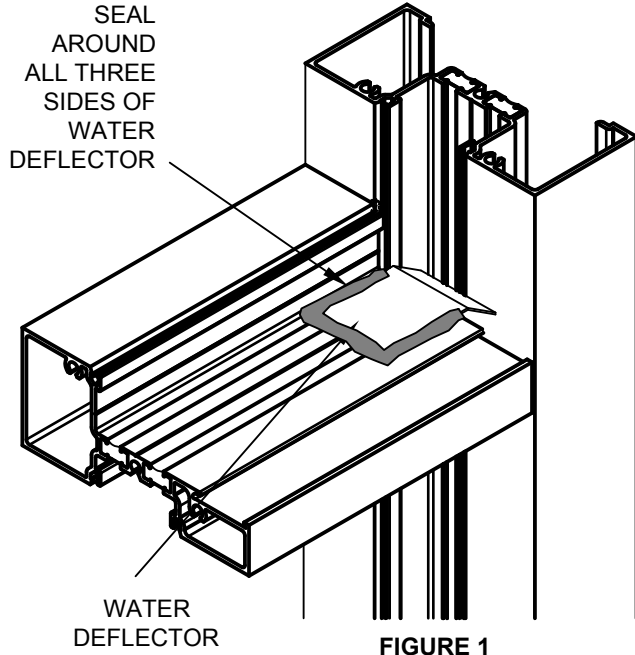

**COLD WEATHER NOTE:**  
 For temperatures below 40° the following precautions should be taken. Just prior to installing the water deflector, wipe glazing pocket with a solvent or cleaning solution recommended by the sealant manufacturer.  
**\*CAUTION:**  
 Carefully follow the recommendations contained in the material safety data sheet provided by the solvent/cleaning solution manufacturer regarding health and fire/explosion risks.

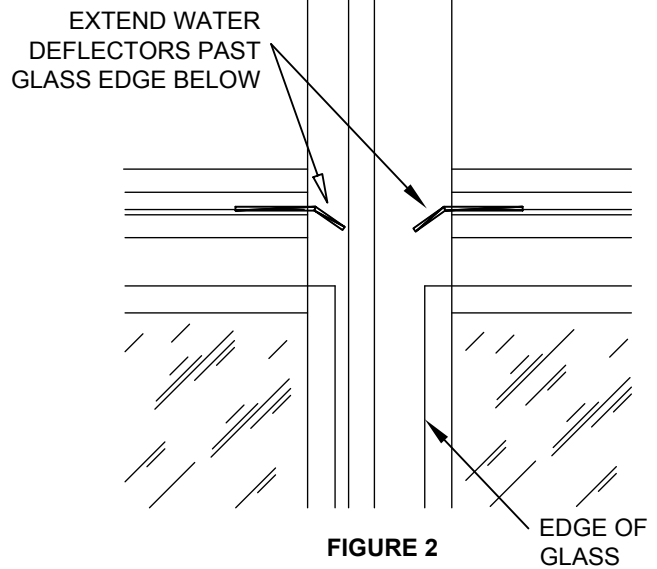

After the water deflector is installed, seal the joint between the back leg of the Horizontal and the Vertical. Make sure to fill the gasket reglets in the area to prevent water from running down the lite below. (Figure 3 and 4)

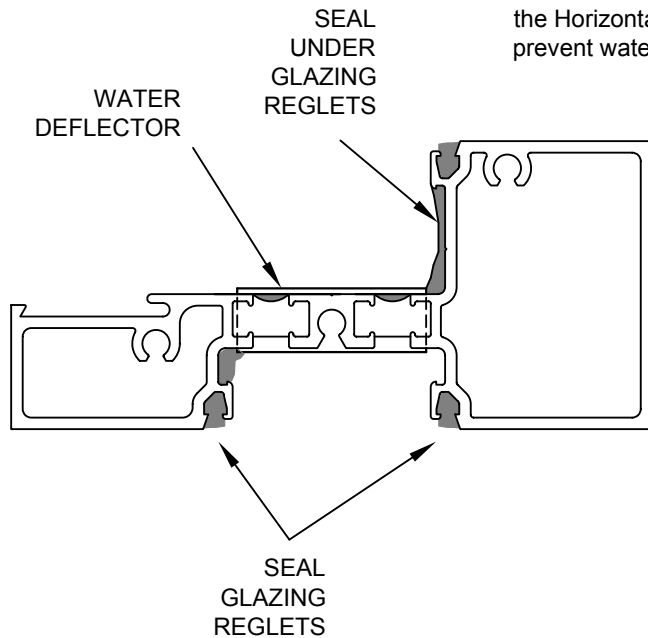

**NOTE:**  
 FOR THERMAL MEMBERS,  
 SEAL UNDER DEFLECTOR  
 FILLING CAVITIES WITH  
 SEALANT. (FIGURE 4)

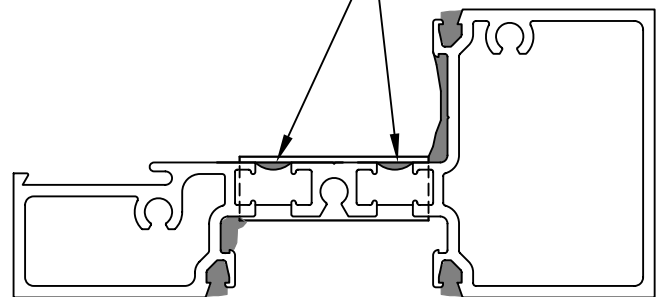

Laws and building and safety codes governing the design and use of glazed entrance, window, and curtain wall products vary widely. Kawneer does not control the selection of product configurations, operating hardware, or glazing materials, and assumes no responsibility therefor.

Kawneer reserves the right to change configuration without prior notice when deemed necessary for product improvement.  
© Kawneer Company, Inc., 2010

### TYPICAL INSTALLATION OF PARTIAL OR FULL LENGTH VERTICAL GLAZING ADAPTERS - PRIOR TO FRAME ASSEMBLY

Vertical glazing adapters may be installed for partial, (**Figure 1**) or full-length, (**Figure 2**) applications at the time the frames are assembled.

**STEP 1:** Cut VERTICAL glazing adapters to D.L.O. Plus 1/2" for partial length applications or to Vertical member length for full-length applications.

**STEP 2:** Cut HORIZONTAL glazing adapters to D.L.O.

**STEP 3:** Snap vertical adapters into glazing reglets of frame and assemble frame as instructed. In partial length applications, vertical adapter should be positioned to allow sealing of the horizontal adapter to the vertical adapter (approximately 1/4" projection into horizontal pocket, **Figure 3**) it may be necessary to lightly crimp vertical adapter in place to prevent sliding.

**SPECIAL NOTE:** When using pre-installed vertical glazing adapters, care should be taken at the time of the frame assembly, to seal the vertical glazing reglets where they meet the intermediate horizontals. The 1/4" water deflector should also be used on all full-length applications (**Figure 4**), and installed as shown in **Section VII**. 1" water deflectors are used for partial adapter applications as long as the adapter does not impede water evacuation of the intermediate horizontal. The water deflector must allow water to drain into the vertical pocket beyond the edge of the glass below.

**STEP 4:** Apply sealant to vertical adapter at the final position of the snapped-in horizontal adapter.

**STEP 5:** Snap the HORIZONTAL glazing adapters into the glazing reglet allowing the adapter to rotate into the pocket and contact the sealant at the vertical adapter.

### INSTALLATION OF GLAZING ADAPTERS - AFTER FRAME ASSEMBLY AND FOR FIELD RETROFIT APPLICATIONS

**STEP 1:** Cut VERTICAL glazing adapters to D.L.O. + 1/2".

**STEP 2:** Make a 1/4" by 1/4" notch at each end of the vertical glazing adapter. Notch should be made on the face side of the adapter nearest the gasket reglet as shown. (**Figure 5**)

**STEP 3:** Cut HORIZONTAL glazing adapters to D.L.O.

**STEP 4:** Snap vertical adapters into glazing reglets of frame. Adapter should be positioned to allow sealing of horizontal adapter to the vertical adapter (approximately 1/4" projection into horizontal pocket, **Figure 3**)

**SPECIAL CARE NOTE:** Care should be taken to insure that the glazing adapter does not impede water evacuation at the intermediate horizontal. The previously installed 1" water deflector must allow water to drain into the vertical pocket the edge of the glass below.

**STEP 5:** Apply sealant to vertical adapter at the final position of the snapped-in horizontal adapter.

**STEP 6:** Snap the HORIZONTAL glazing adapters in the glazing reglet allowing the adapter to rotate into the pocket and contact the sealant at the vertical adapter.

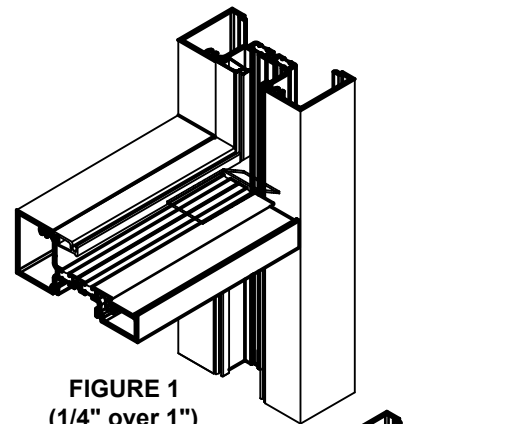

**FIGURE 1**  
(1/4" over 1")

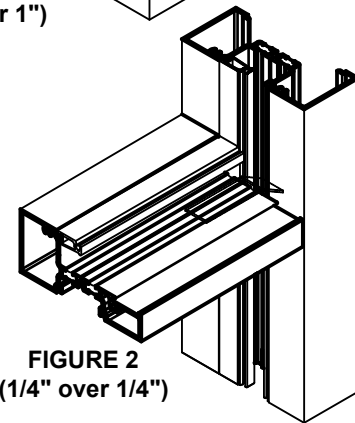

**FIGURE 2**  
(1/4" over 1/4")

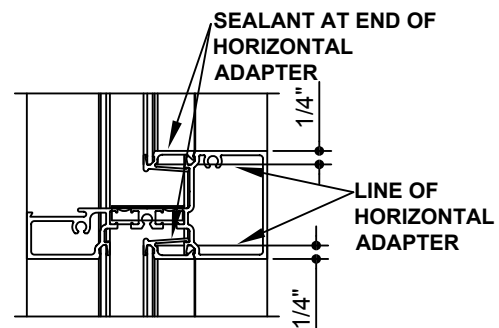

**FIGURE 3**

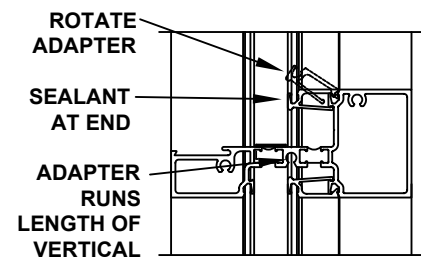

**FIGURE 4**

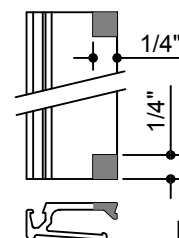

**FIGURE 5**

**NOTES:**

- 1) THESE FORMULAS DO NOT ALLOW FOR UNDERSIZE OR OUT OF SQUARE DAYLITE OPENINGS.
- 2) THE GLASS MANUFACTURER MUST INDICATE THE SPECIFIC GLAZING REQUIREMENTS FOR THE MATERIAL BEING USED.

**NOTE:**

IF PERIMETER SEAL WAS NOT INSTALLED PREVIOUSLY, INSTALL IT NOW, MAKING SURE IT MARRIES TO ALL RECEPTORS, JAMBS, END DAMS, AND SPLICES.

**STEP A:** All pockets for 1" infill are 1-3/8" in width and will accept up to 1-1/8" glass dry glazed. All pockets for 1/4" infill are 5/8" in width, and will accept up to 3/8" glass dry glazed.

**STEP B:** Glass size is D.L.O. (Daylight Opening) + 3/4" for captured systems.

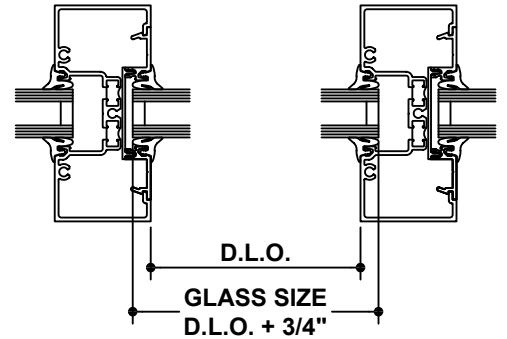

**GLAZING CHART FOR 1" SYSTEM**

Infill Thickness	*Adaptor	Weathering for Typical Systems
1/8"	451-VG-029	027-077 (Both Sides)
1/4"	451-VG-029	027-074 (Both Sides)
3/8"	451-VG-029	027-076 (Both Sides)
1/2"	451-VG-030	027-077 (Both Sides)
5/8"	451-VG-030	027-074 (Both Sides)
3/4"	451-VG-030	027-076 (Both Sides)
7/8"	_____	027-077 (Both Sides)
1"	_____	027-074 (Both Sides)
1-1/8"	_____	027-076 (Both Sides)

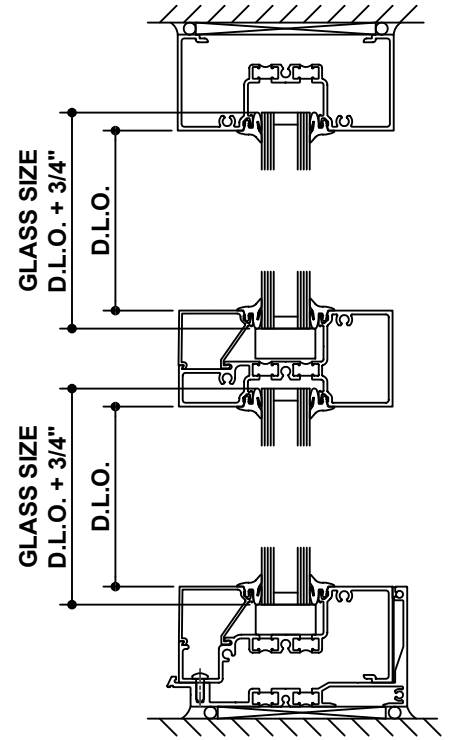
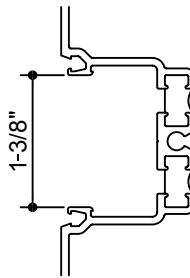

**NOTE:** For infill thickness in 1/16" increments or oversize and undersize glass, use a combination of the standard (027-074) with either the light (027-076) or heavy (027-077) gaskets.

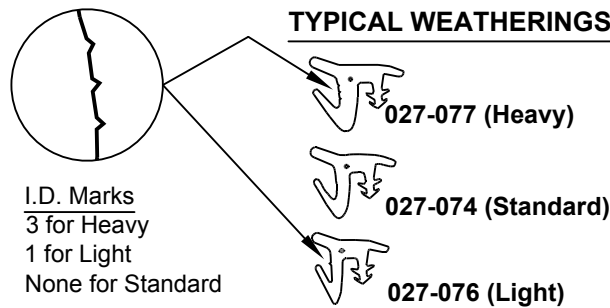

**\*NOTE:**

Snap-in glazing adaptors 451-VG-029 and 451-VG-030 are provided for applications requiring infills less than 1" in thickness at adaptation. Reference Page 48, Glazing Adaptors, for adaptor cut lengths and seal information.

One "W" Side Block should be installed into the deep pocket of the mullion of each lite of glass in the opening.

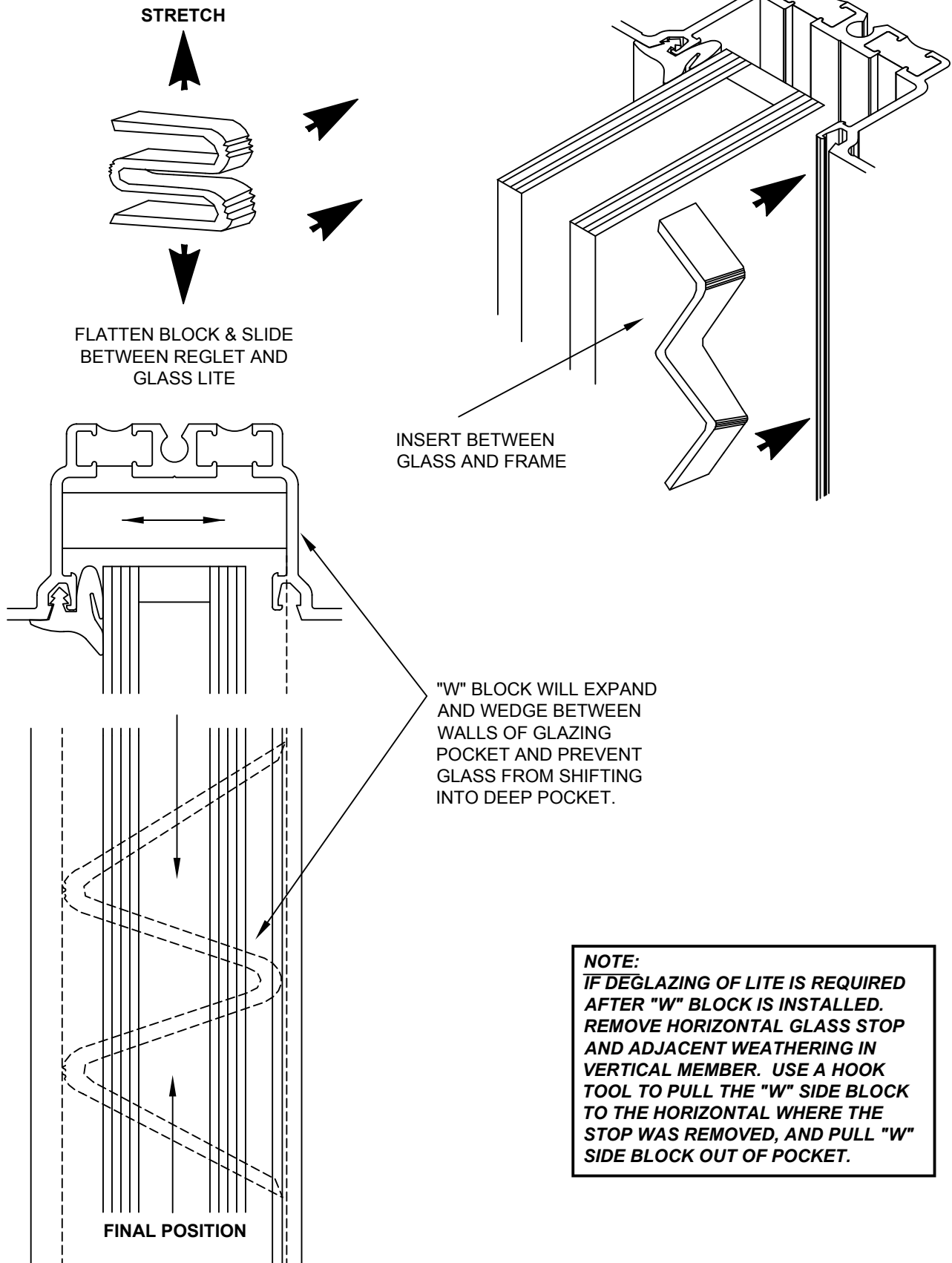

Laws and building and safety codes governing the design and use of glazed entrance, window, and curtain wall products vary widely. Kawneer does not control the selection of product configurations, operating hardware, or glazing materials, and assumes no responsibility therefor.

Kawneer reserves the right to change configuration without prior notice when deemed necessary for product improvement.

© Kawneer Company, Inc. 2010

- STEP 1:** Cut horizontal and vertical gaskets to an approximate length of D.L.O. + 1/4" per foot of D.L.O.
- STEP 2:** Install gaskets on the side of frame opposite glass stops first.
  - A. Insert gaskets into the horizontal members first starting at the ends and work toward the center as shown. (See Figure 1)
  - B. Install vertical gaskets into the same side of frame after horizontal gaskets are in place in the same manner.
- STEP 3:** Position setting blocks at points under glass as required.
- STEP 4:** Install glass into frame using standard flush glazing technique.
- STEP 5:** Run bead of sealant along vertical reglets where glass stop meets, then install glass stop.
- STEP 6:** Install horizontal and vertical gaskets into glass stop side of frame in the same manner as described in Step #2.

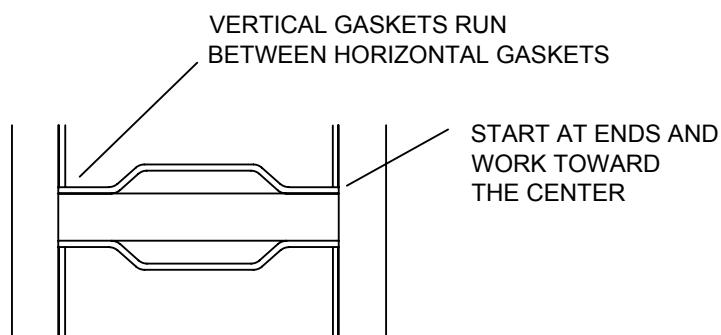
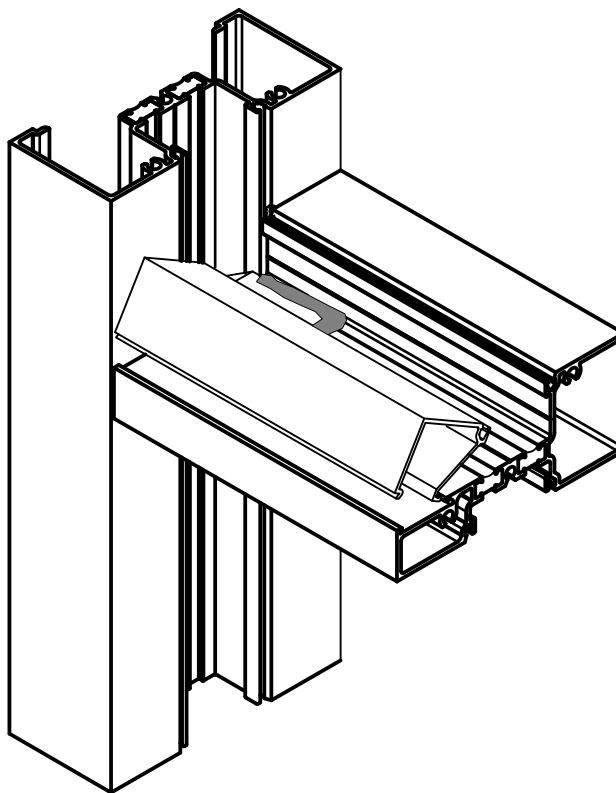

**FIGURE 1**

**ADJUSTABLE BRAKE METAL CORNERS**

Use the same preps as are required for the standard vertical, refer to page 15.

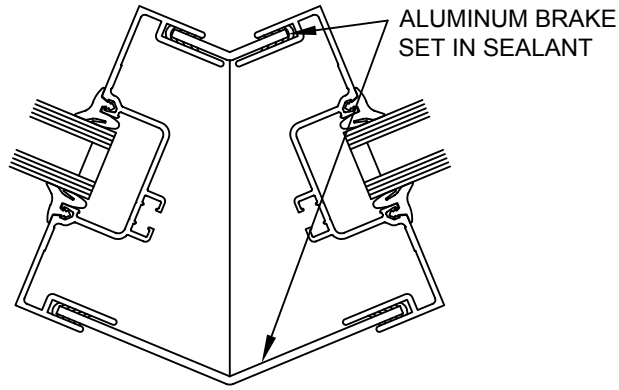

**PIVOTED INSIDE AND OUTSIDE CORNERS**

Use the same preps as are required for the standard vertical, refer to page 15. Drill (#26) and countersink 0.147 diameter holes for assembly screws (#10 x 9/16"). Fasten together with supplied screws. Screws should be located 6" from each end and 24" on center.

**NOTES:**  
 1) **CONTINUOUS WEATHERING INSTALLED INTO BOTH INTERIOR AND EXTERIOR OF CORNER HALVES BEFORE ASSEMBLY.**  
 2) **LAYOUT AND CUT SIZES CAN BE DETERMINED USING PIVOT CENTER LINES.**

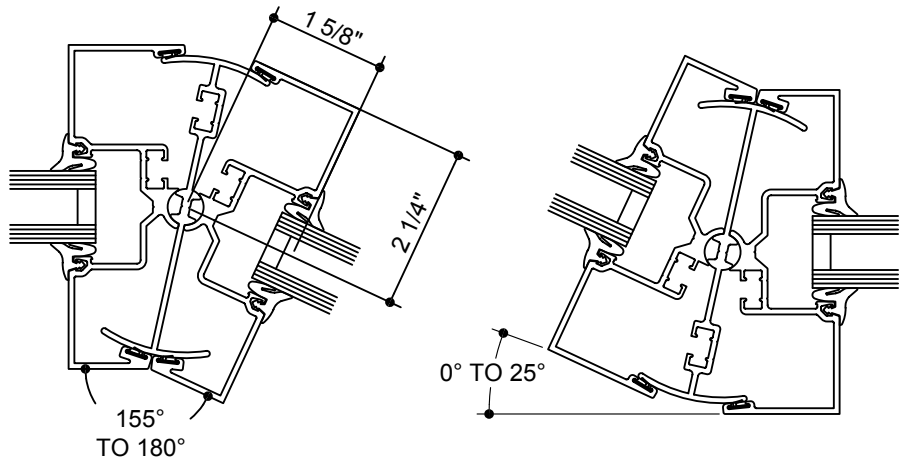

**SNAP CORNERS**

Use the same preps as are required for the standard vertical, refer to page 15. Snap corners together as shown.

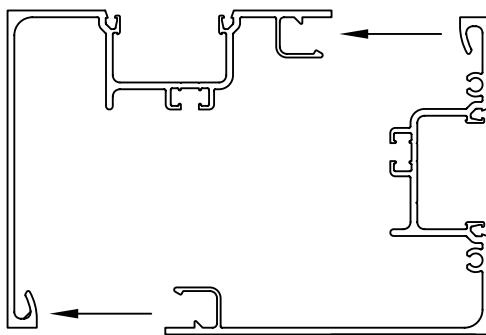

90° CORNER

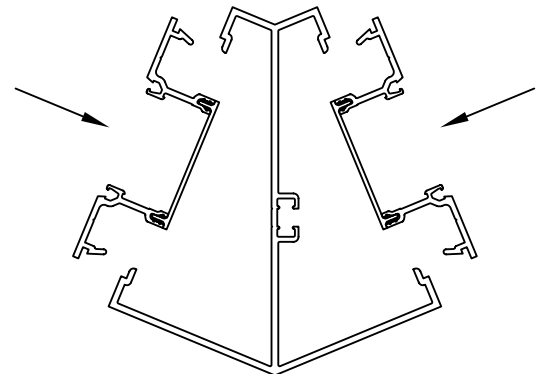

135° CORNER

**NOTE:**  
**TIGHT SNAPS MAY BE WAXED TO MAKE ENGAGEMENT EASIER.**  
**CORNERS ARE NOT DESIGNED TO BE UNSNAPPED.**

Laws and building and safety codes governing the design and use of glazed entrance, window, and curtain wall products vary widely. Kawneer does not control the selection of product configurations, operating hardware, or glazing materials, and assumes no responsibility therefor.

Kawneer reserves the right to change configuration without prior notice when deemed necessary for product improvement.  
 © Kawneer Company, Inc., 2010

**EXPANSION MULLIONS**

An expansion mullion is to be used every 20' in large openings. The dimension of the assembly should be adjusted based on the temperature at the time of assembly and expected high and low service temperatures use reference dimension. (For example, the sight line will be reduced slightly when installed in hot weather and increased slightly when installed in cold weather).

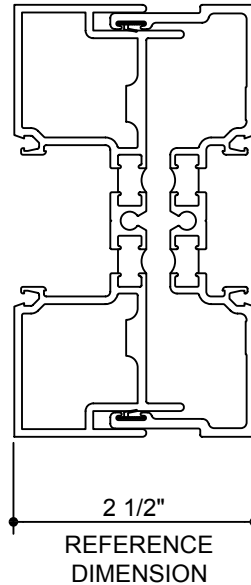

**NOTE:**  
**DO NOT LINE UP**  
**EXPANSION**  
**MULLIONS WITH**  
**THE SPLICE JOINT**  
**OF THE HEAD AND**  
**SILL RECEPTORS**

**STEEL REINFORCING**

Steel reinforcement should be cut to mullion length minus 12" and fastened into place to prevent movement of the steel in the mullion. Position steel 6" from top of mullion and 6" from bottom of mullion, providing room for the mullion anchors. The cut ends of the steel reinforcing must be coated with a corrosion-inhibiting primer before installation.

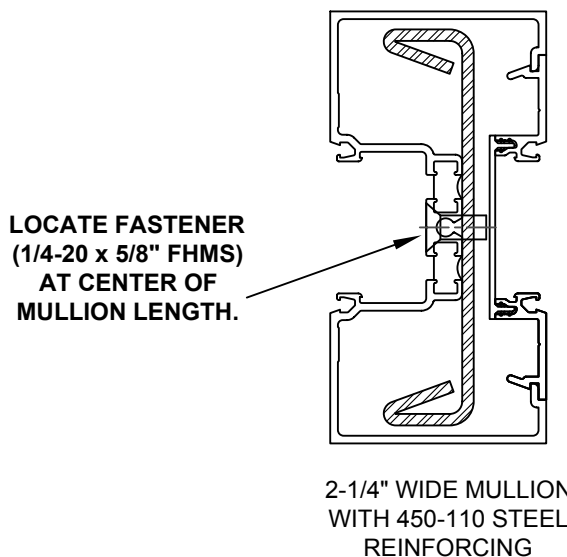

**NOTE:**  
**CONSULT**  
**APPLICATION**  
**ENGINEERING FOR**  
**FRONT AND BACK**  
**PLANE SYSTEMS**  
**WITH STEEL**  
**REINFORCING**

2-1/4" WIDE MULLION WITH 450-110 STEEL REINFORCING

Laws and building and safety codes governing the design and use of glazed entrance, window, and curtain wall products vary widely. Kawneer does not control the selection of product configurations, operating hardware, or glazing materials, and assumes no responsibility therefor.

Kawneer reserves the right to change configuration without prior notice when deemed necessary for product improvement.  
© Kawneer Company, Inc., 2009



KAWNEER COMPANY, INC  
TECHNOLOGY PARK/ATLANTA  
555 GUTHERIDGE COURT  
NORCROSS, GA 30092