

# The Anesthesia Delivery System

## Troubleshooting and Overview



# Learning Objectives -

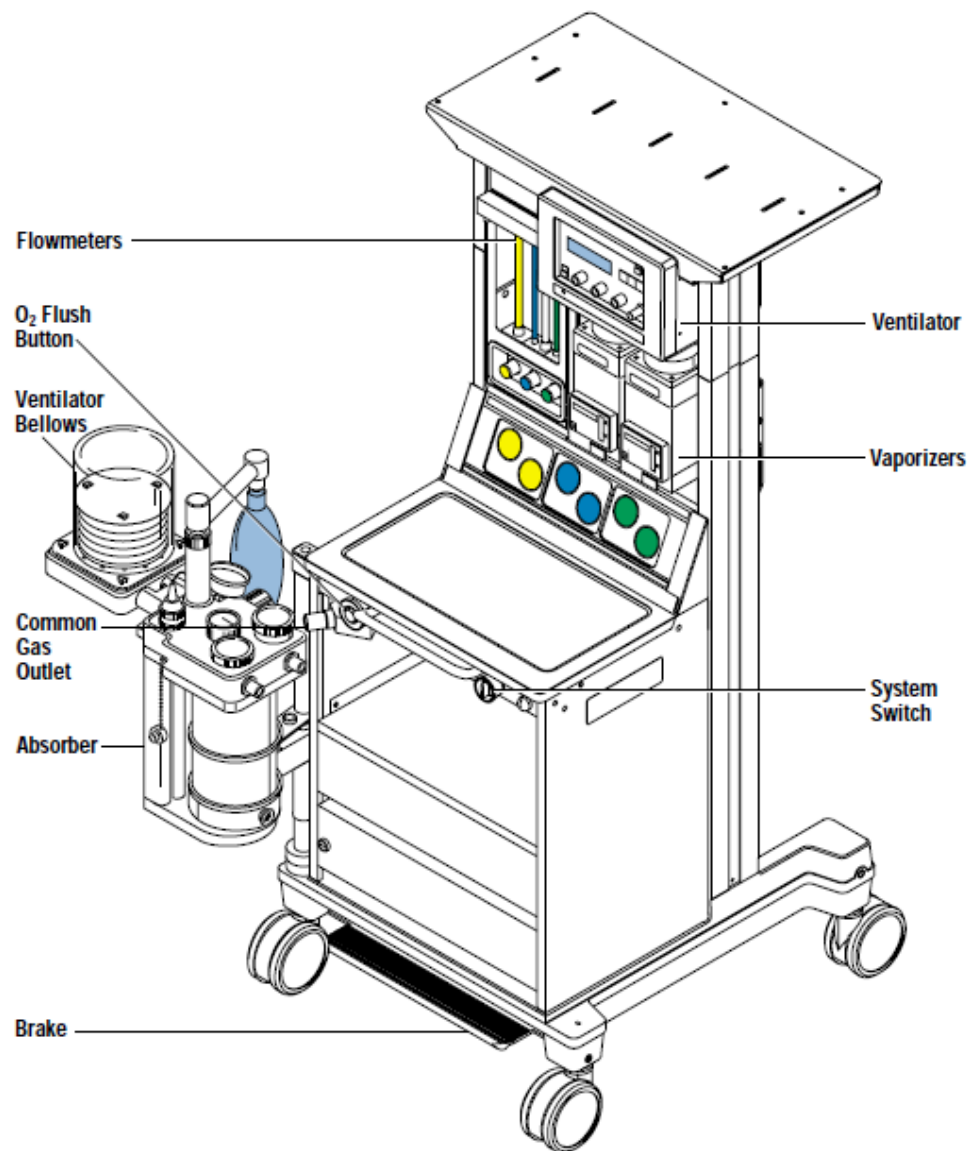
- Explore the major components, internal and external, of the anesthesia system.
- Analyze the components part in failure scenarios.
- Explain the steps of isolating, troubleshooting and solving the failures.

# Learning Objectives -

- Illustrate the importance of good habits during pre-operative testing of the equipment.
- List the functions of an anesthesia system as defined by the ASTM.
- Increase patient safety by sharing knowledge and best practices. We are all part of the care giving team!

# Disclaimer -

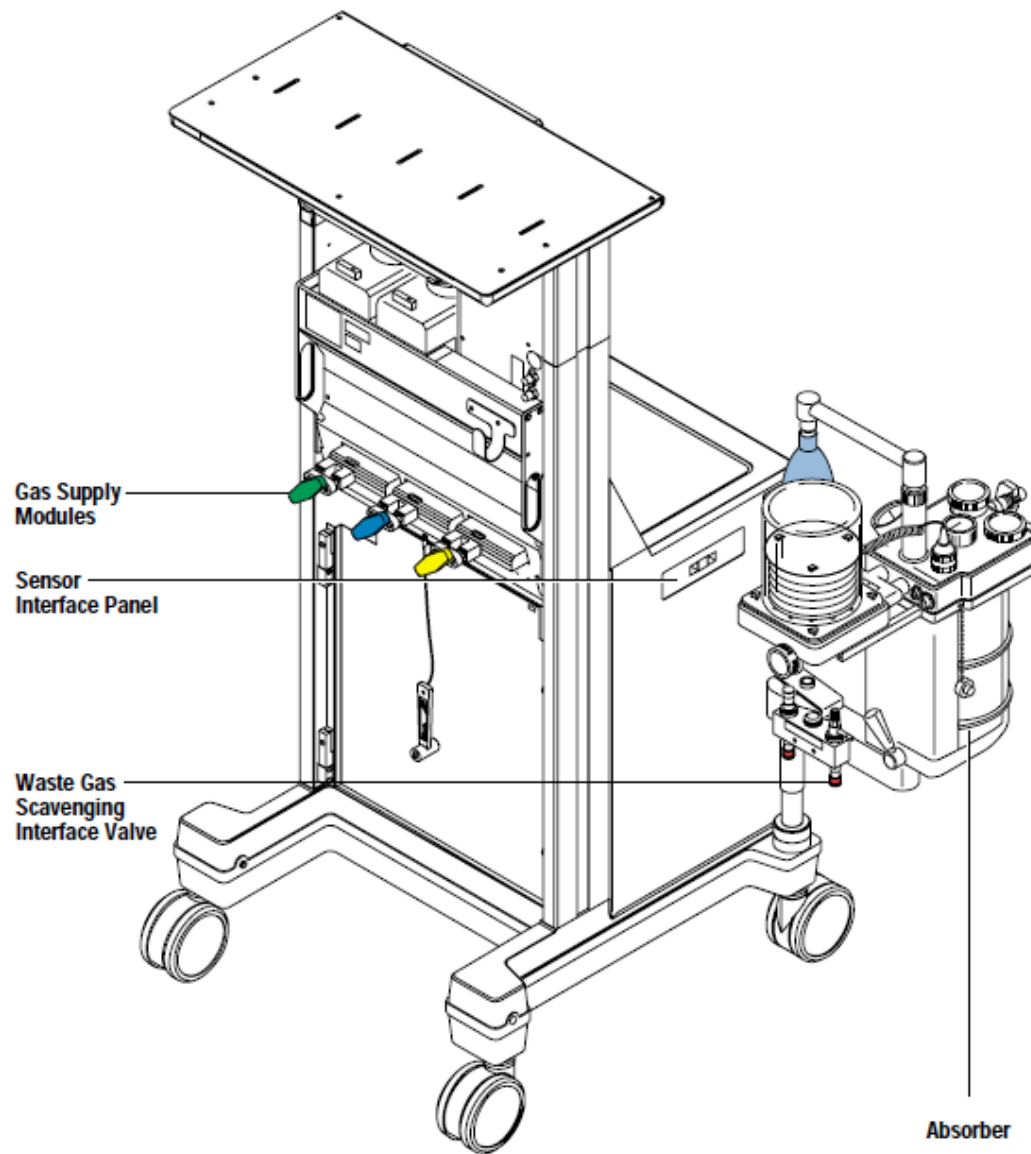
- The materials contained in this document are intended for educational purposes only. The material does not establish any specifications, operating procedures, or maintenance methods for any of the products referenced. Always refer to the manufacturer's official documentation.



## The Anesthesia System: defined by ASTM

( Work-station )  
( Care-station )

- Supplies blended anesthesia gases and anesthetic vapors to the patient.
- Provides manual and mechanical ventilation capabilities.

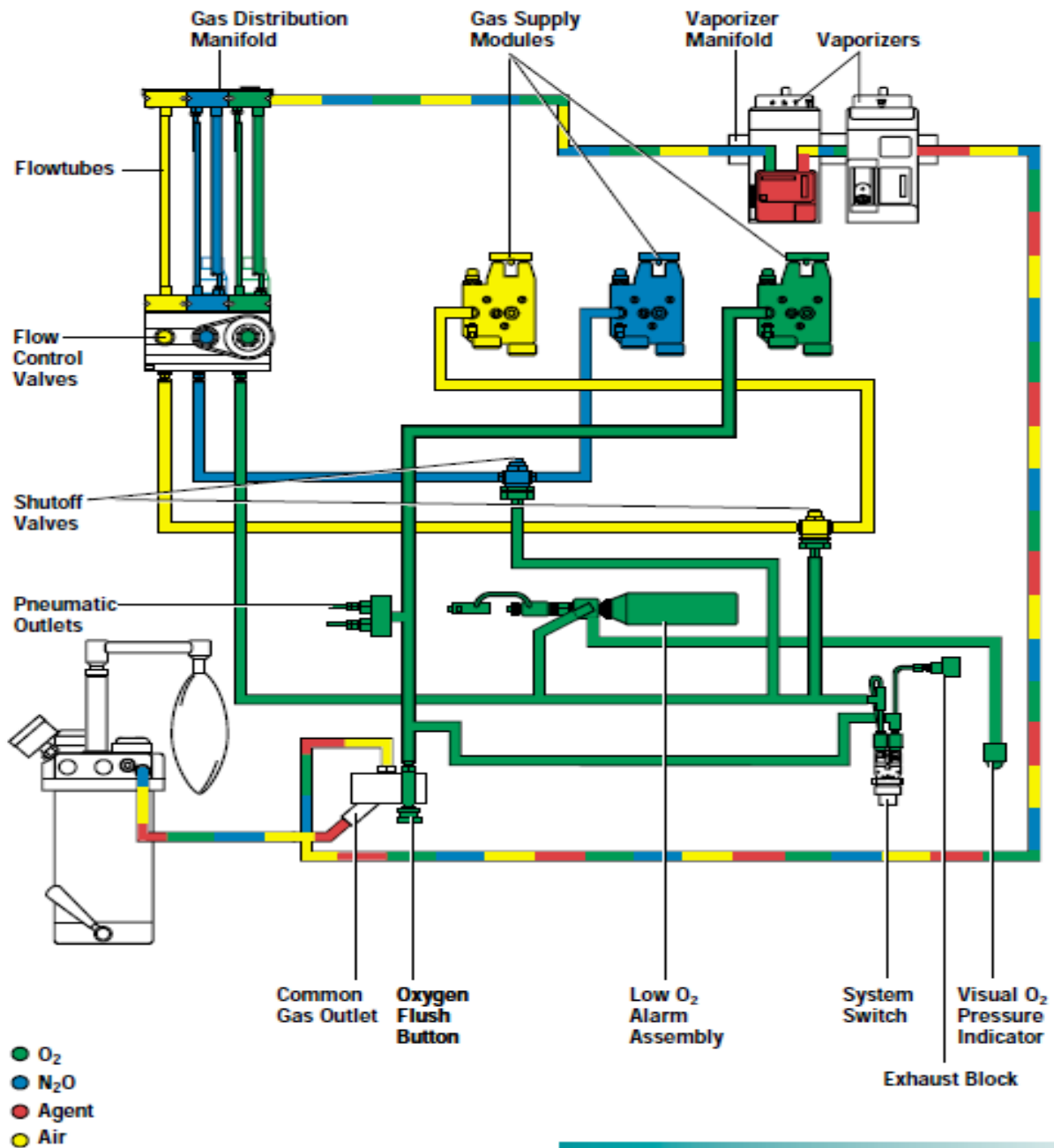


## The Anesthesia System:

- Monitors O<sub>2</sub> concentrations
- Offers protection devices and alarms designed to keep users and patients safe.
- Interfaces with the facilities waste gas scavenging system to remove excess gas.

Illustration 6

Gas flow through the anesthesia machine



**Dr. Lewis is working in OR6 at St. Michaels Hospital today and Bev, CRNA, is working with him. The anesthesia system in OR6 is an older Datex-Ohmeda Excel/7800 system. Just as the patient is intubated, the ventilator alarms “Low O2 Supply.” The flow meters drop to zero. Dr. Lewis panics and calls the workroom for help!**





## GAS SUPPLY Troubleshooting

### Question:

As Dr. Lewis and Bev stabilize the patient, Paula enters the room and turns on the oxygen cylinder. The alarm silences and Paula begins to troubleshoot; she notes that the oxygen supply hose is connected to the wall. Where might Paula look to determine if the oxygen supply pressure at the wall connector is adequate?

### Answer:

The machines onboard supply gauges



## **GAS SUPPLY Troubleshooting**

### **Question:**

**Paula determines that the wall supply pressure was zero. Turns out, a workman had inadvertently turned off the rooms zone valve. Luckily, Bev had checked the oxygen cylinder during her pre-op check and determined 1500 psi was present. Even luckier, she remembered to turn the tank off after testing. What if Bev did not turn the tank off after testing; how would this scenario be different?**

### **Question:**

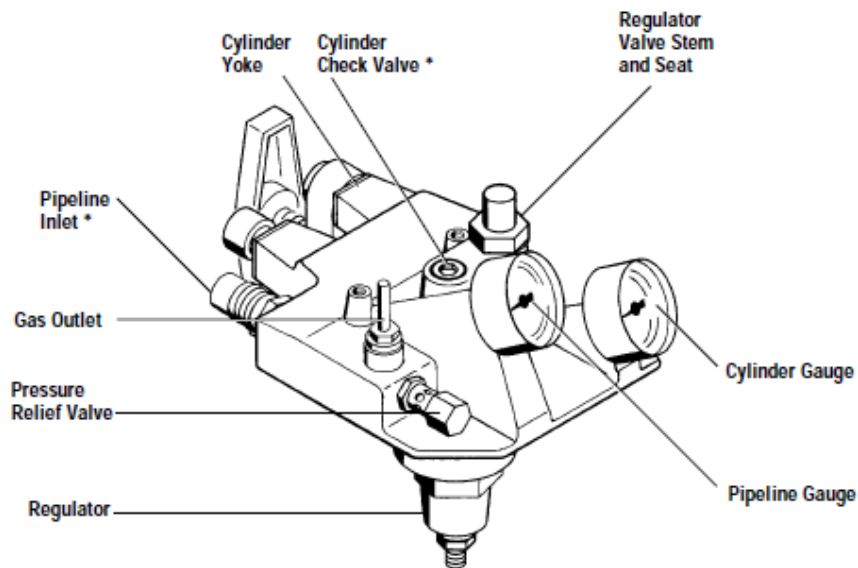
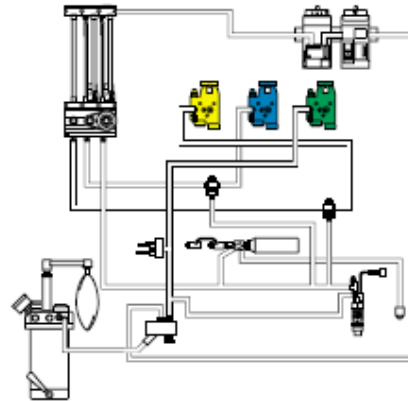
**Under normal circumstances, if both the wall supply and cylinder supply are both connected to a machine and both are of adequate pressure and the cylinder is on. Which supply supplies the oxygen to the machine?**

### **Answer:**

**The Wall Supply supplies the machine under normal circumstances.**

### Illustration 8

The different components of the gas supply module

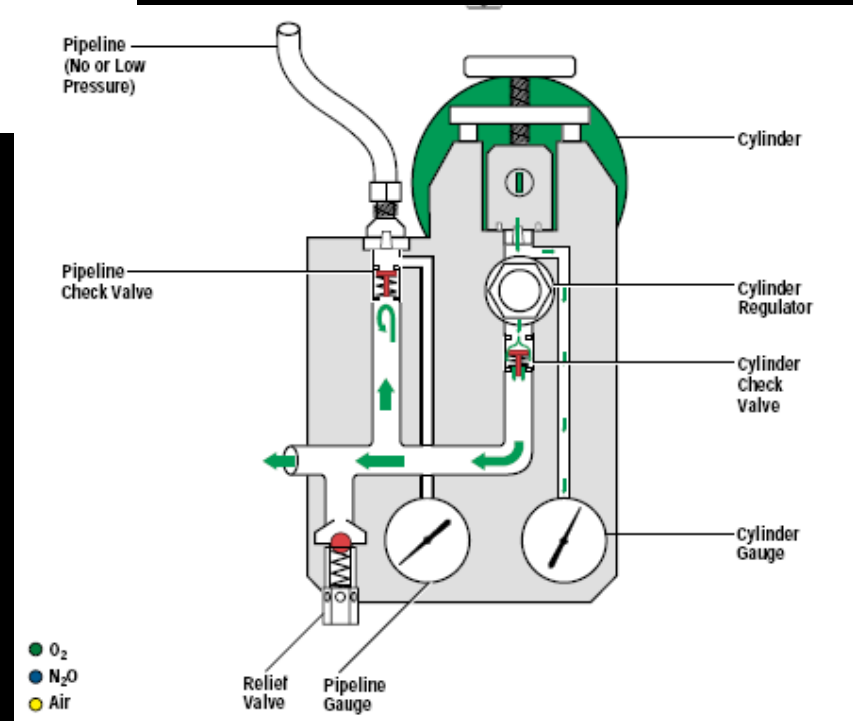
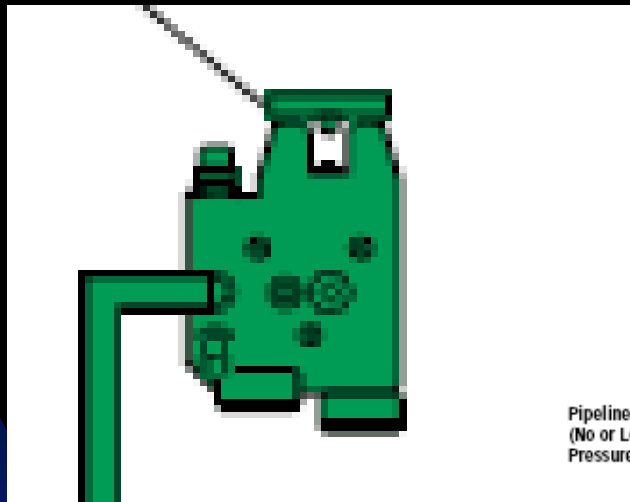


- O<sub>2</sub>
- N<sub>2</sub>O
- Air

\* Note: The pipeline inlet filter and check valve are internal.

## The Gas Supply Module includes:

- A cylinder branch
- A pipeline branch
- Pressure gauges
- Safety systems



**The Gas Manifold has TWO inputs and ONE output !!**

**Joe Hill, CRNA is checking the pressure of his N2O tank in OR2 and as soon as he opens the valve, the sound of a large rushing of air is heard inside the machine. He closes the valve and the sound dissipates. He calls Mike from Biomed for help.**



## GAS SUPPLY Troubleshooting

### Question:

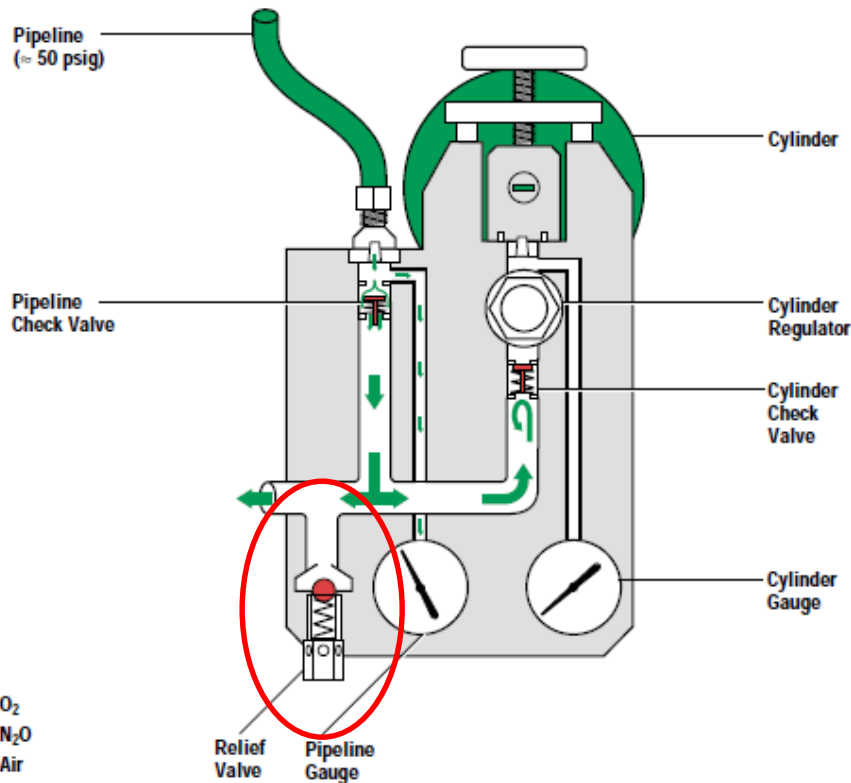
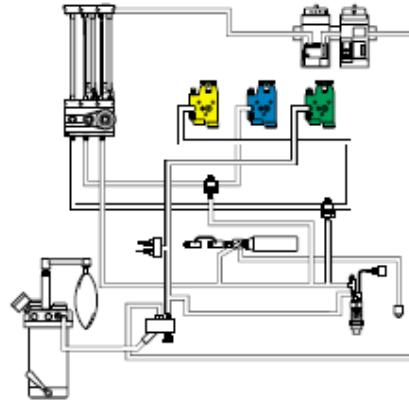
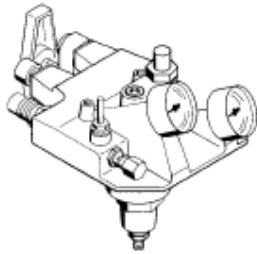
**Mike determines that a failure has occurred with the N<sub>2</sub>O cylinder regulator on the gas supply module and the “rushing of air” sound was completely expected. What is Mike talking about?**

### Answer:

**The gas supply module has a built in safety relief valve that opens to atmosphere at 75 psi.**

Illustration 13

Pipeline in use, cylinder check valve closed



## The Gas Supply Module:

- Check valves prevent leakage
- A relief valve will open if pressure increases above ~ 75 psi

## **GAS SUPPLY Troubleshooting**

**We have been talking about the cylinders a lot.  
Lets EXPLORE them a little.**

**Question:**

**How much volume is left in a N<sub>2</sub>O “E” cylinder that reads 750 psi?**

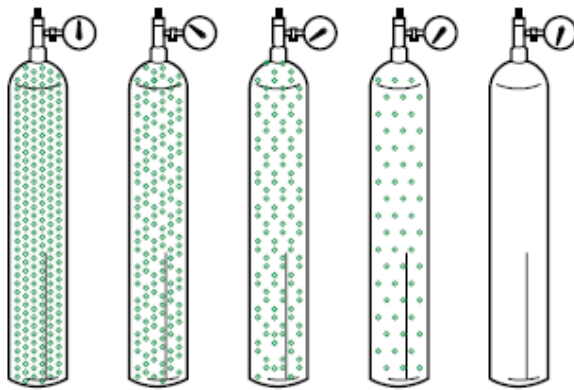
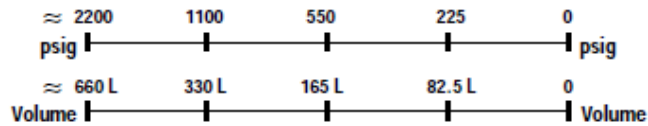
**Answer:**

**Somewhere between 1600 and 300 liters. The pressure will remain constant as long as liquid N<sub>2</sub>O is present in the cylinder.**

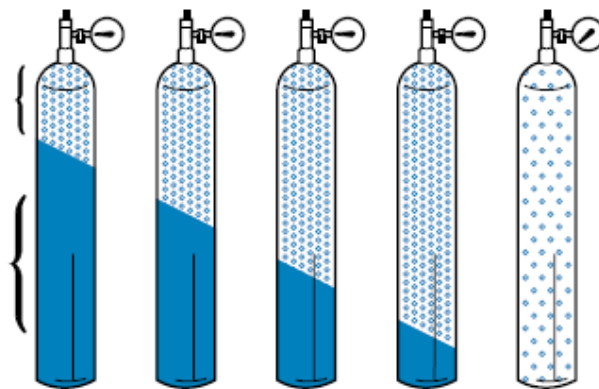
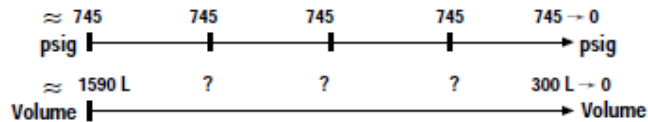


Illustration 2

E size cylinder volumes and pressures



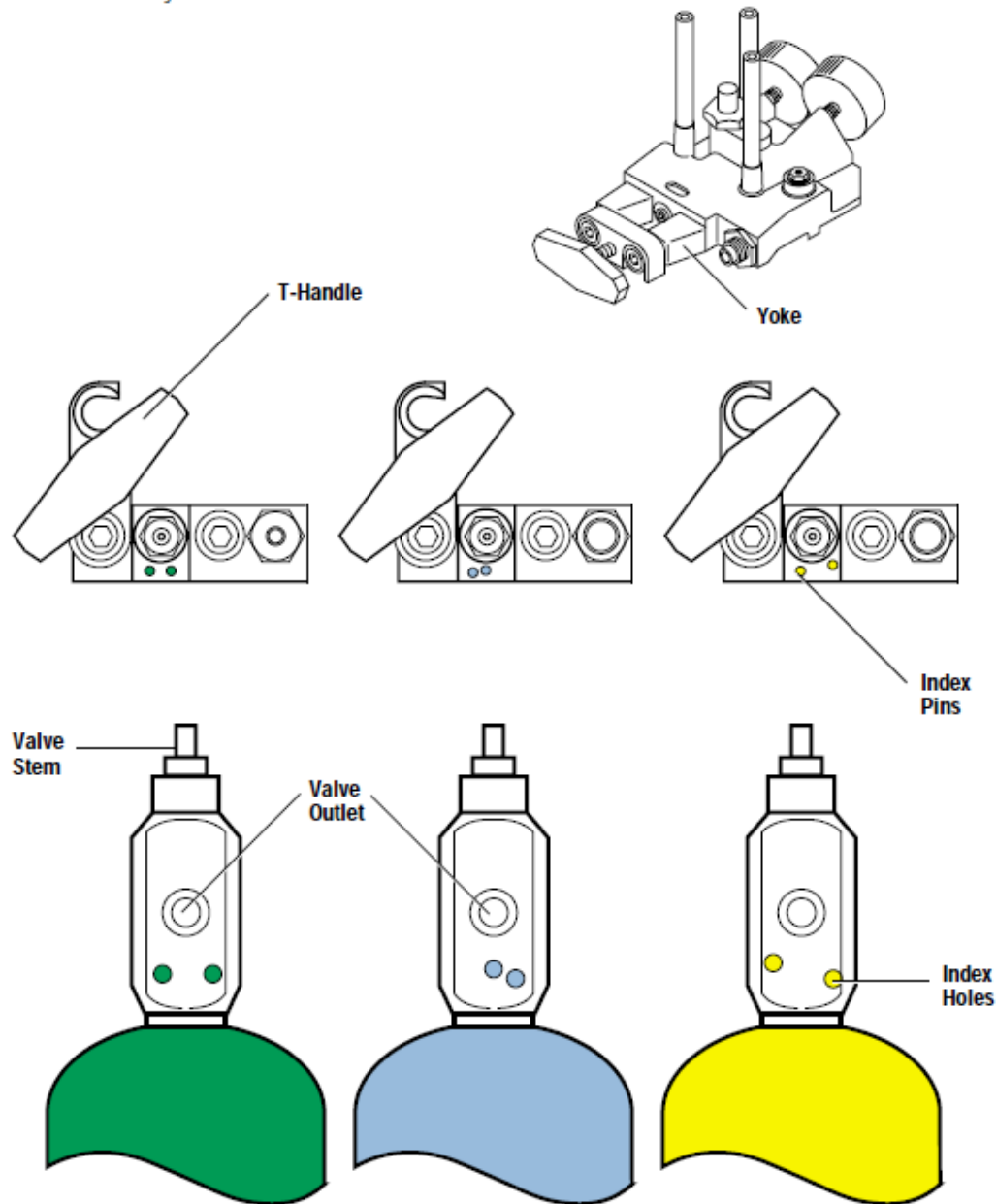
Oxygen Cylinders



Nitrous Oxide Cylinders

## Cylinder Supplies:

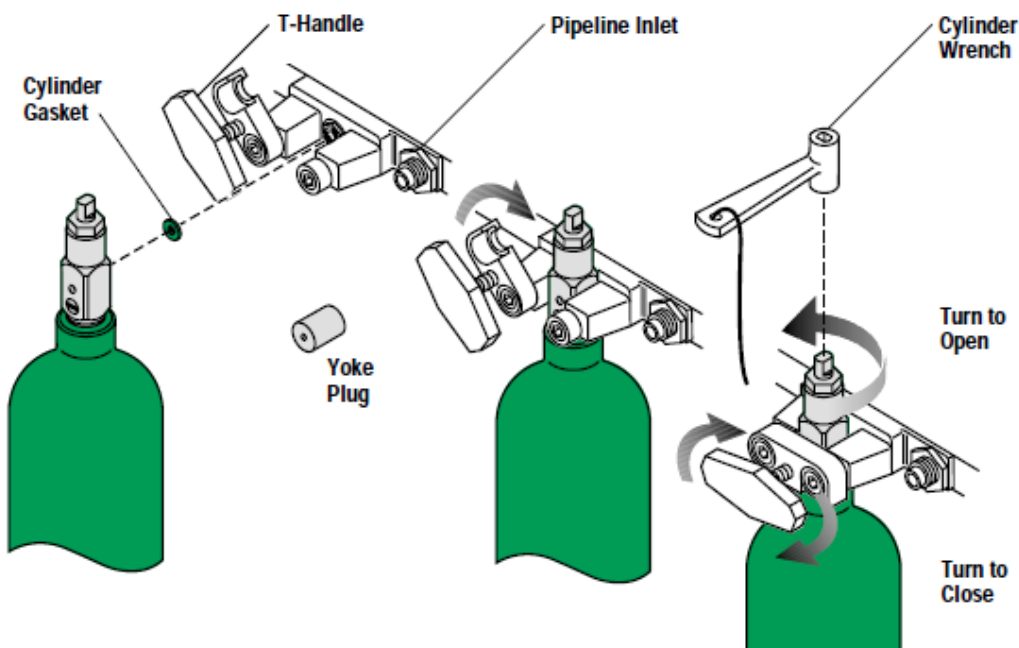
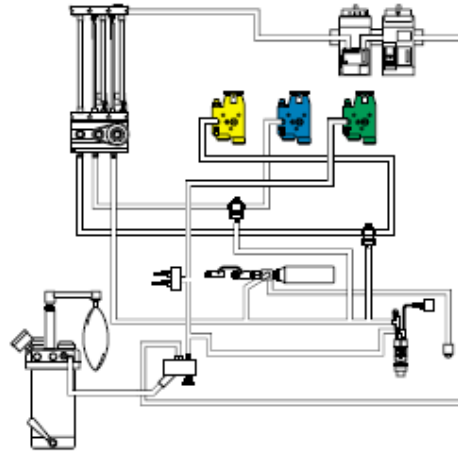
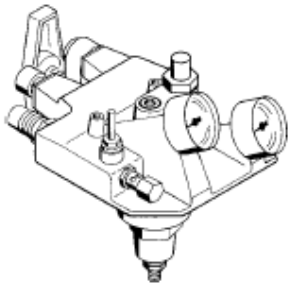
- Cylinders are intended to be the secondary or emergency gas supply to the anesthesia system.
- Cylinders are high pressure devices and should be handled and stored carefully!



## Pin Indexing Safety System – PISS:

- Unique pin set for each available gas cylinder.
- “E” Cylinders are also color coded for safety.
- Pins should always be intact and secure!

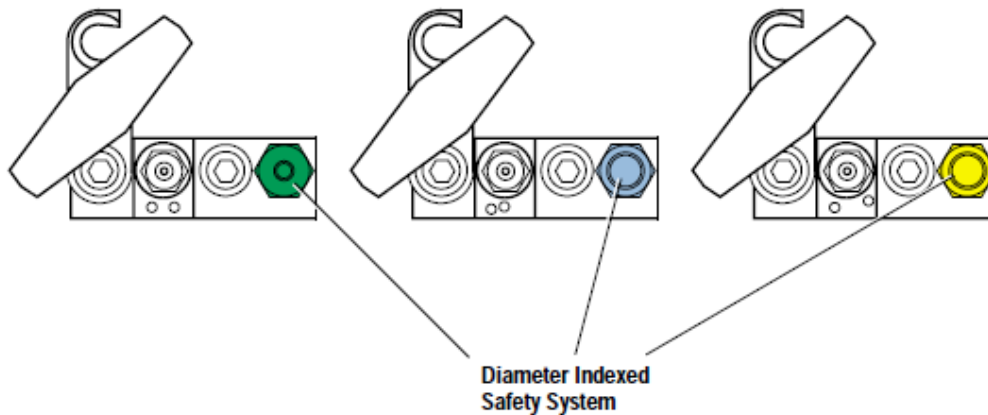
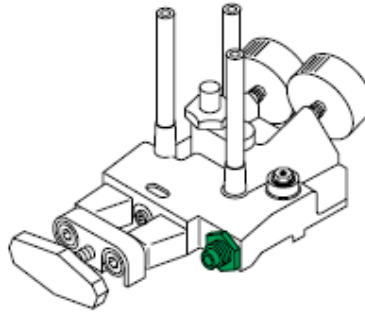
How to install a cylinder or a yoke plug



## Installation:

- Use a new cylinder gasket with each new cylinder.
- Make sure that *two* gaskets are not being used!
- Using your foot to stabilize the cylinder may help.

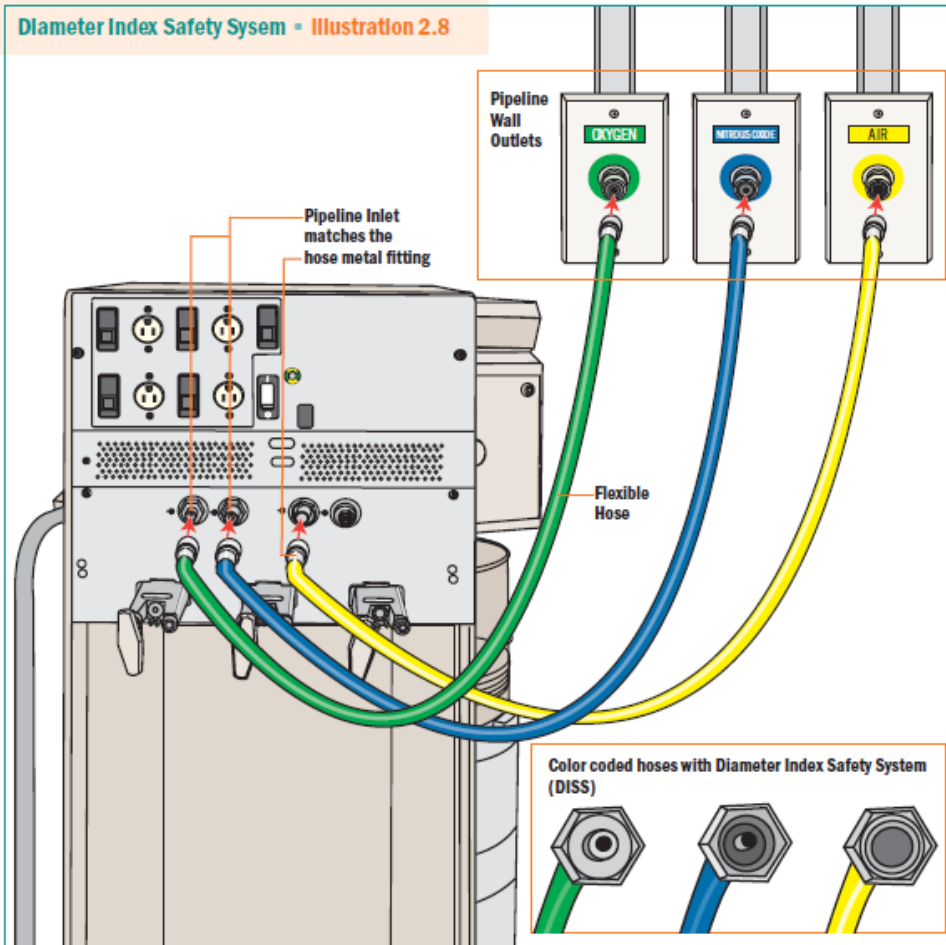
DISS inlet connections on the anesthesia machine



## Diameter Indexing Safety System – DISS:

- Unique diameter (inside and outside) for each available gas supply.
- Fittings and hoses are also color coded for safety.

Diameter Index Safety System • Illustration 2.8



2.13

## Pipeline Supply:

- Many styles of wall outlet fittings exist.
- Normal wall supply pressure is 45 – 55 psi.

## Summary of Pipeline and Cylinder Criteria:

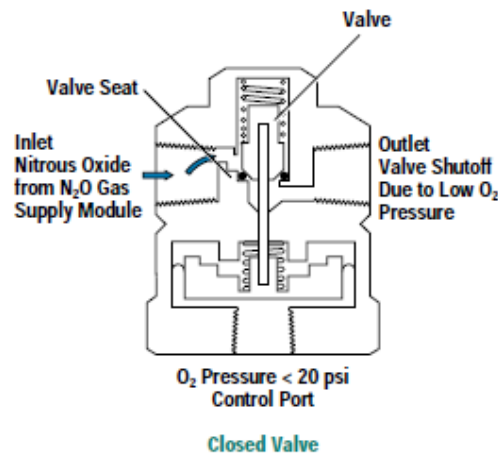
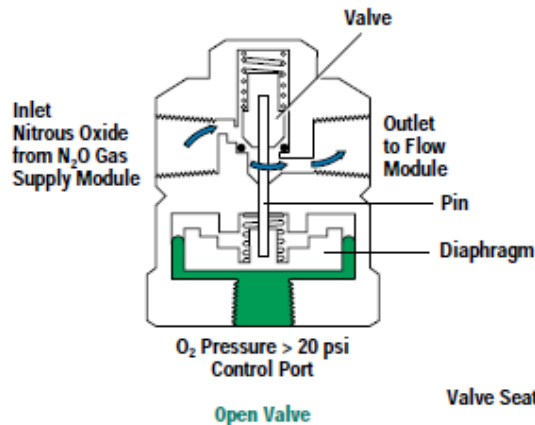
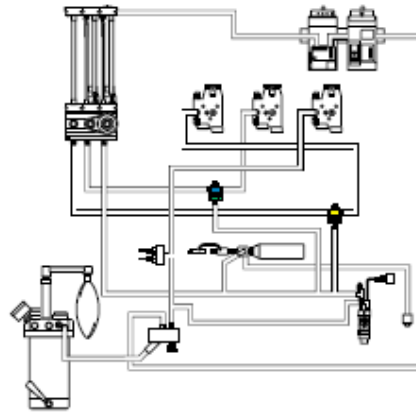
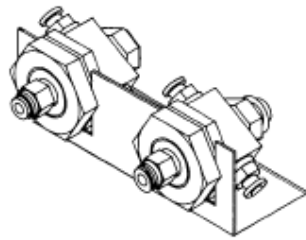
- Anesthesia work-station provides both pipeline and cylinder inputs.
- Pressure gauges for each input
- DISS and PISS safety systems
- Input filters and check-valves
- Cylinder systems have pressure reducing regulators.

What is the first device that will inform you of a crossover (non-oxygen gas in the oxygen pipeline)?

Is it the fail-safe?

Is it the hypoxic guard?

Shutoff valve open and closed



- O<sub>2</sub>
- N<sub>2</sub>O
- Air

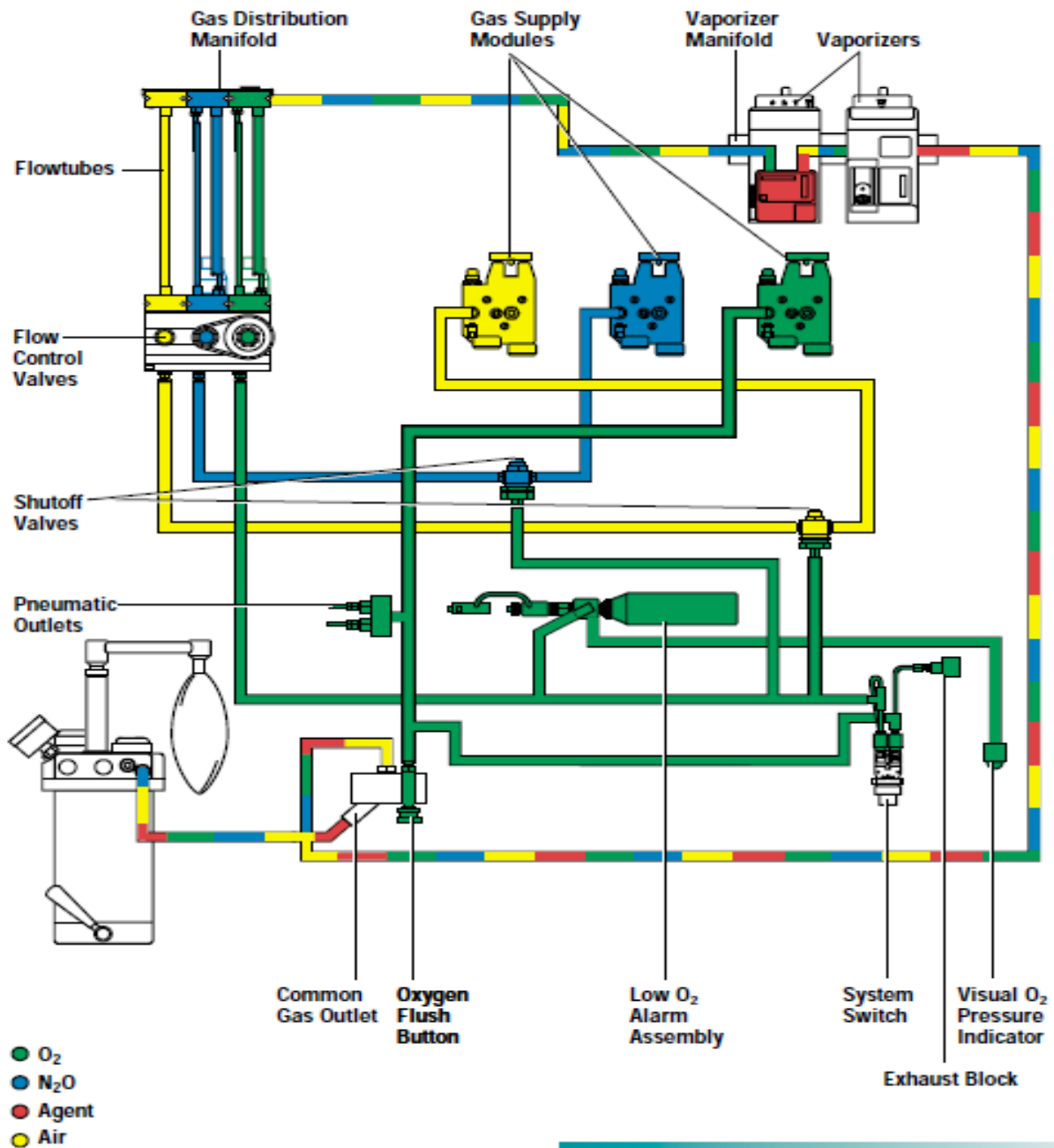
## Shut-off (Fail-Safe) Valves:

- Prevents the flow of other gases like nitrous-oxide when oxygen pressure is less than 20 psi.
- Newer anesthesia machine designs do not have a shut-off valve on the Air supply.

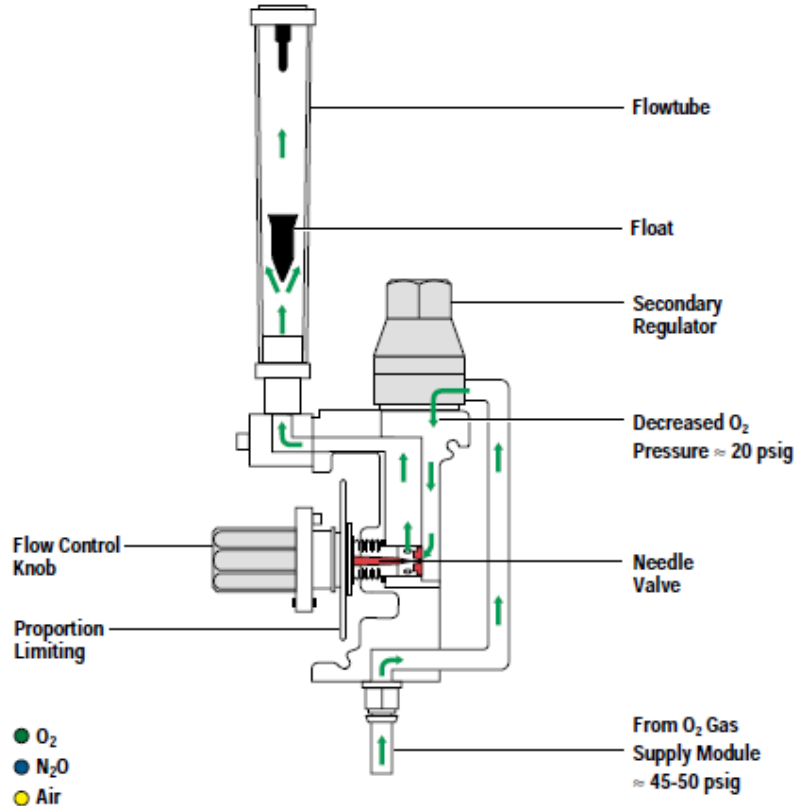
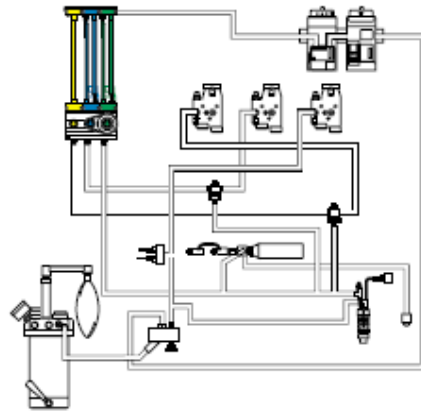


Illustration 6

Gas flow through the anesthesia machine



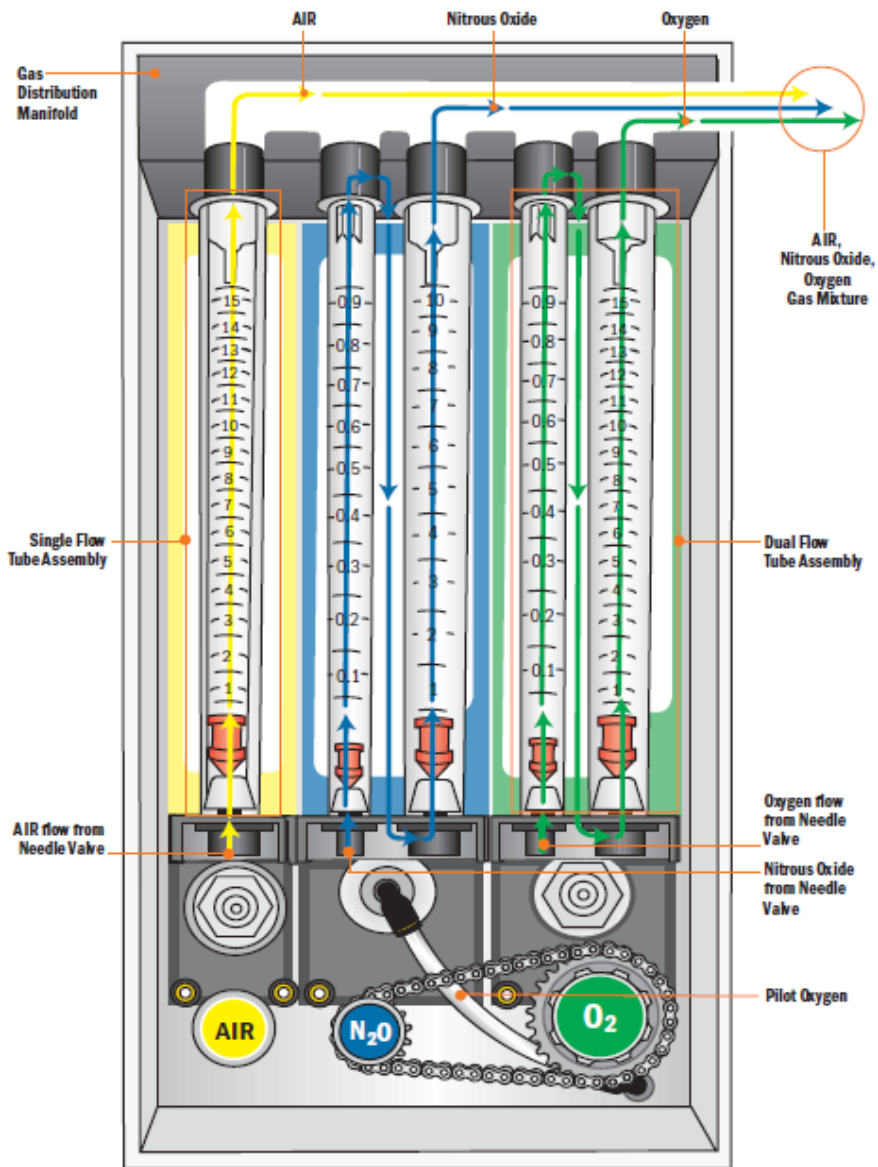
Flow control assembly



## Flow Control Assembly:

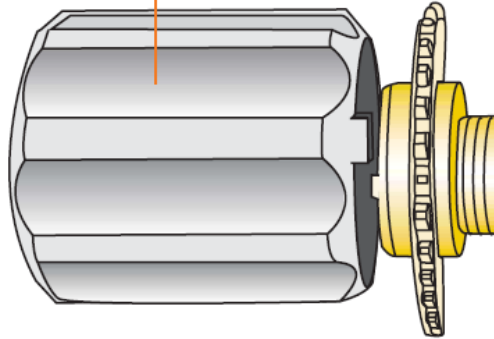
- Nitrous-oxide and oxygen are linked together to prevent a hypoxic mixture.
- Gas flow is controlled by a needle valve design
- O<sub>2</sub> flow control knobs feel differently.
- Minimum O<sub>2</sub> flow is machine specific.

Mixed Gas Distribution Path • Illustration 3.12

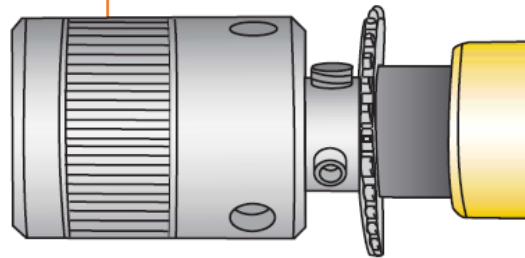


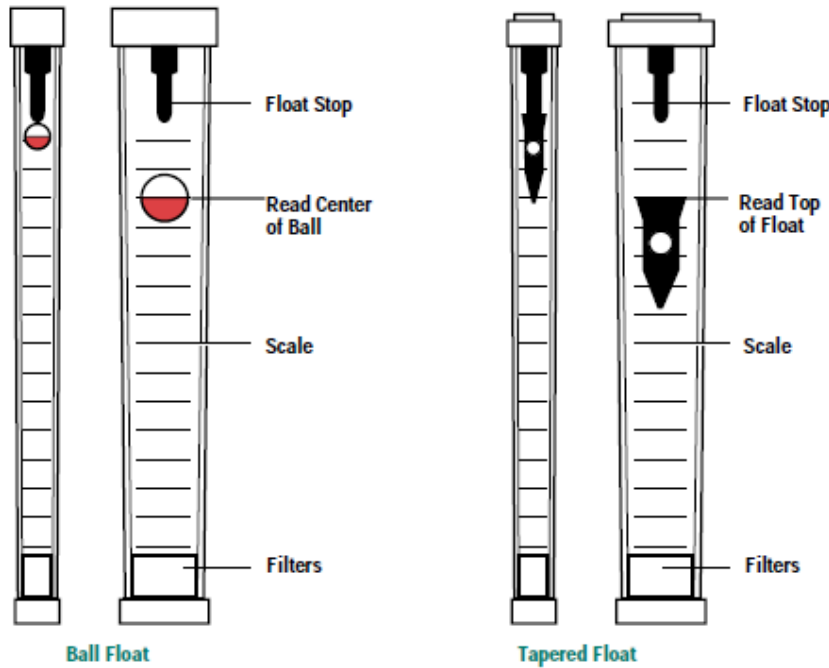
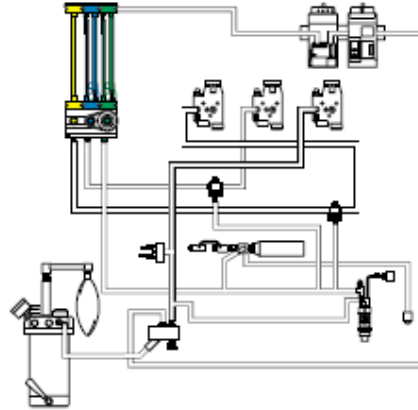
# Oxygen flow knob is uniquely designed – Fluted vs. Knurled

D Fluted Oxygen Flow Control Knob



D Knurled Nitrous Oxide Flow Control Knob



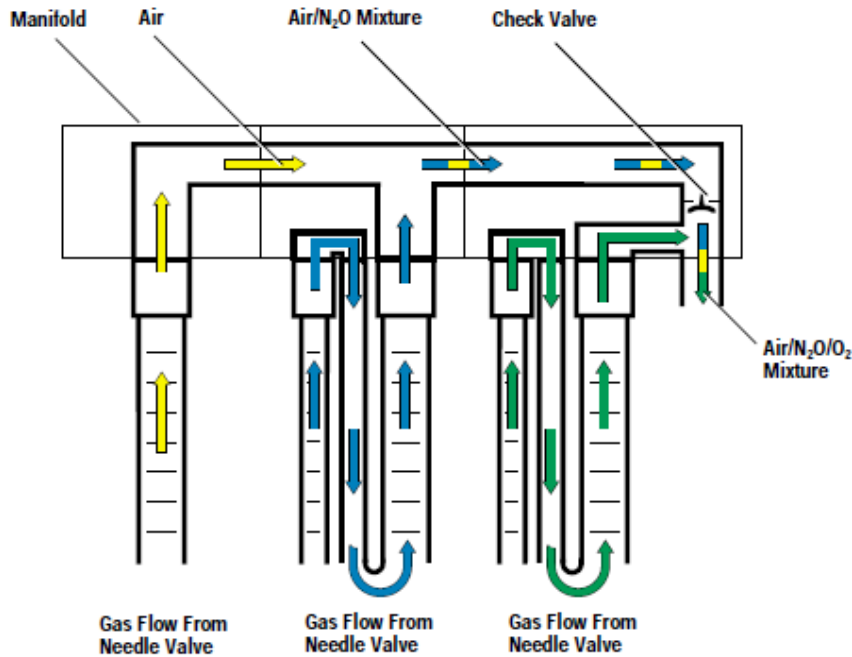
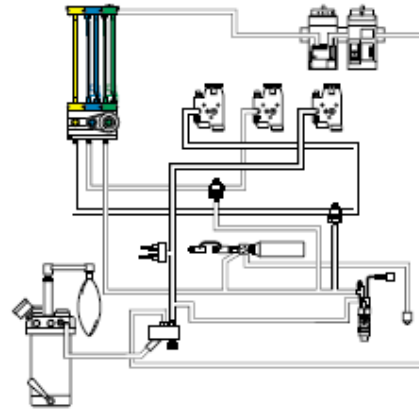
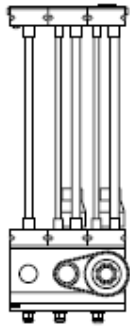


- O<sub>2</sub>
- N<sub>2</sub>O
- Air

## Float Types:

- Ball type – read the center of ball.
- Float type – read the top of float.
- Some floats are fluted and spin to give visual confirmation of gas flow.
- Flow tubes are tapered glass with etched markings.

Flow into the gas distribution manifold



- O<sub>2</sub>
- N<sub>2</sub>O
- Air

## Common Gas Manifold:

- Oxygen is always downstream to all the other gases. Oxygen is always on the right.
- Dual flow tubes are connected in series.
- Some current anesthesia machine designs use graphical images of flow-tubes on a display screen.

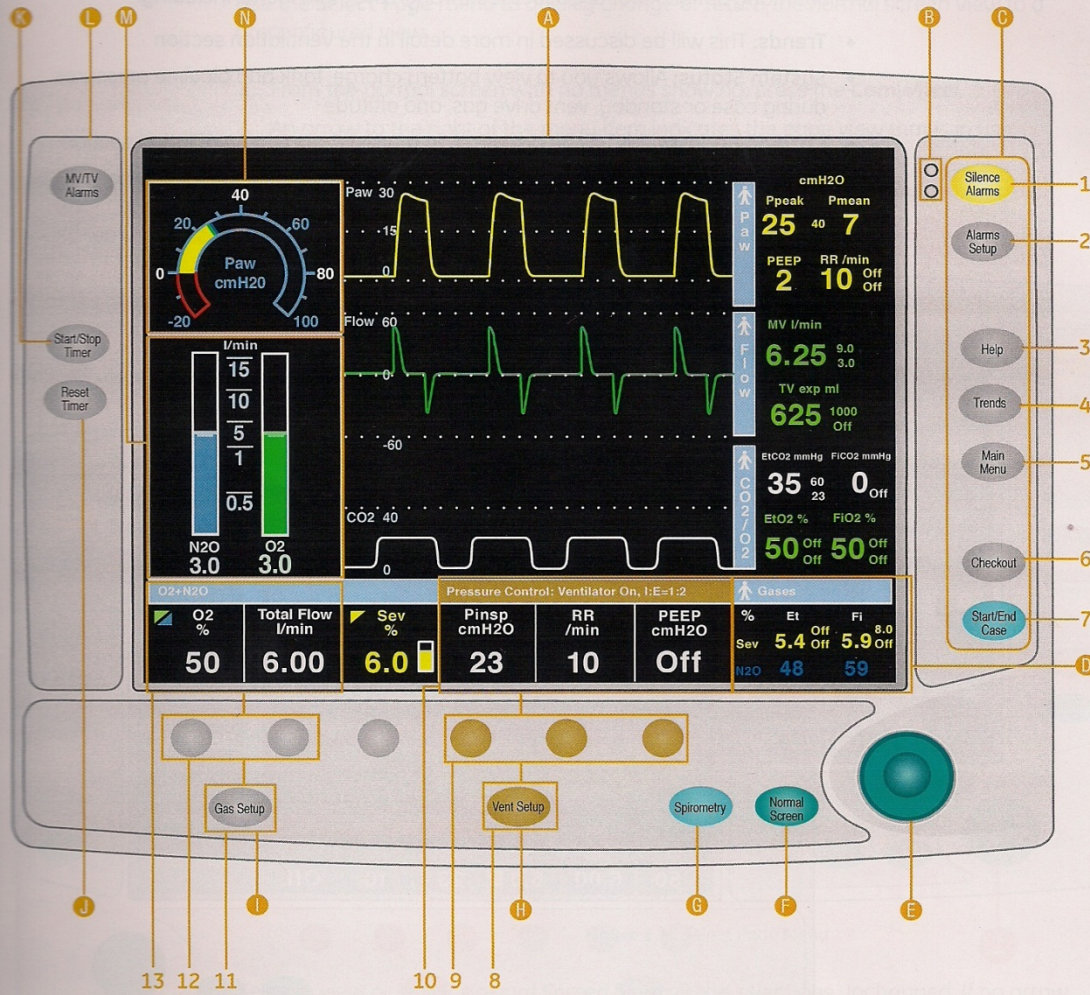


Figure 2.4 Anesthesia Display

2 Participant Guide





What is the first device that will inform you of a crossover (non-oxygen gas in the oxygen pipeline)?

**The Oxygen Analyzer !**

**Susan Jones, CRNA, is working in OR 3 at Frick Hospital. She sets a 50/50 mix of O<sub>2</sub> and N<sub>2</sub>O; 1 lpm each. The O<sub>2</sub> monitor is reading 75%, not 50% as expected. You did the O<sub>2</sub> calibration this morning but skipped the low pressure leak test. You call the anesthesia tech into the room.**

**Scenario:**



## **GAS SUPPLY Troubleshooting**

**The anesthesia tech brings in another O2 sensor but the scenario does not change....the O2 analyzer is reading accurately at 100% but reads high when O2 is mixed. The machine is pulled from service after your short case and sent to the Biomed shop.**

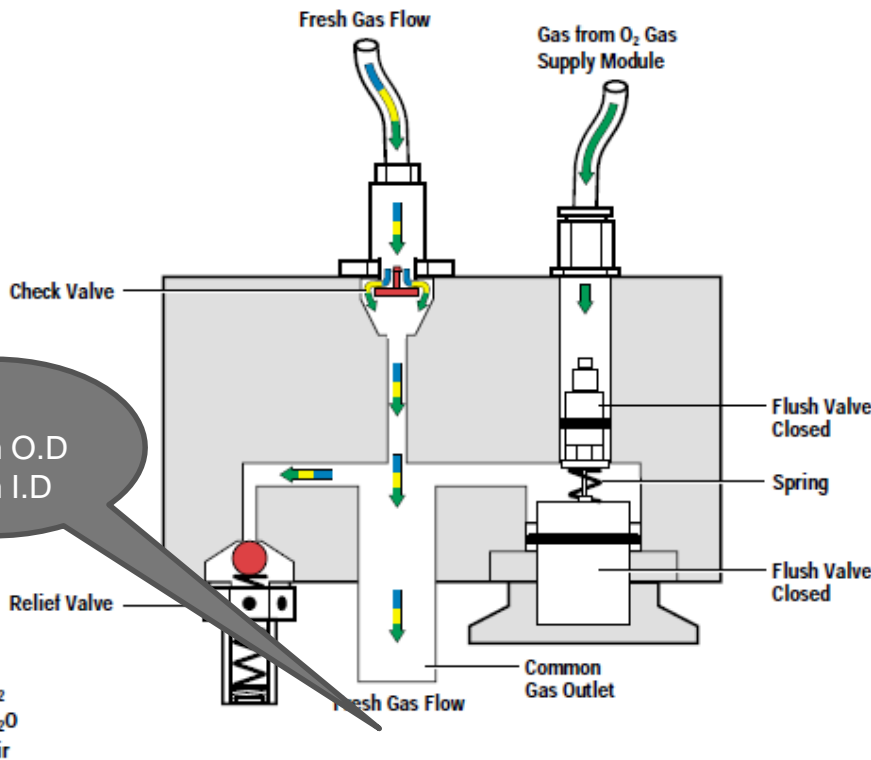
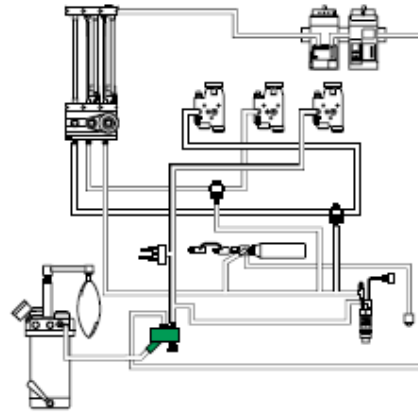
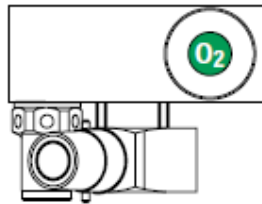
**Question:**

**Biomed determined that a part failed on the machine. Can you think of the device on the machine that failed?**

**Answer:**

**The O2 flush button developed a 2 lpm leak. This flow was diluting the mixture at the common gas outlet. Could this failure of been detected prior to the case starting?**

When the oxygen flush button is released, the spring closes the valve.



## Common Gas Manifold / O<sub>2</sub> Flush Valve:

- Fresh blended gas is delivered to the CO<sub>2</sub> absorber via the common gas outlet.
- The flush valve can deliver 30 – 75 lpm of O<sub>2</sub>.
- Connection point of low pressure leak test device on some model machines.



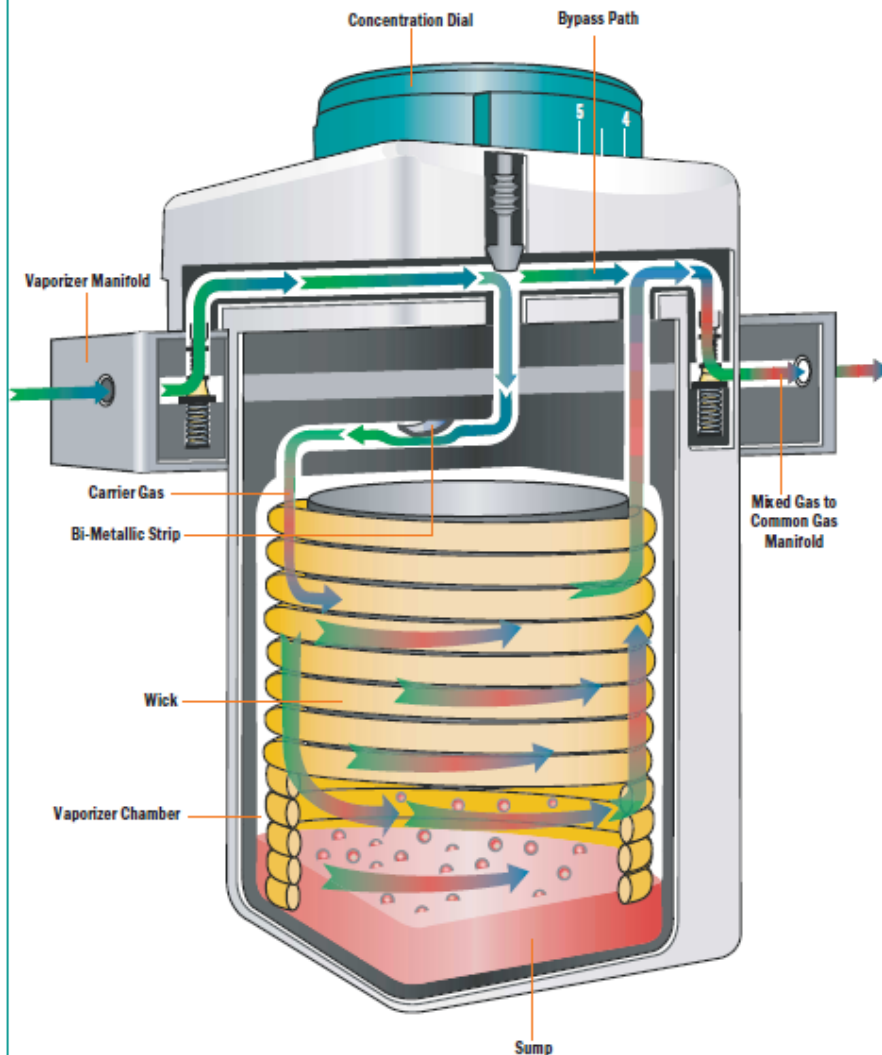
## Scenario:

**Vicky is a CRNA working in OR4 today and begins her morning set up. The room is equipped with a Datex-Ohmeda Tec 7 Isoflurane vaporizer. Vicki notices an occasional drip from a port in the front of the vaporizer. What can she do?**

**Tighten the drain screw**



How a vaporizer works • illustration 4.5



## Vaporizers:

- Flow over design type splits the incoming gas flow.
- Isoflurane, Halothane, and Sevoflurane are flow over vaporizers.
- Desflurane is a pressurized injection type vaporizer.
- Do not tip vaporizers!

**Sam Smith, CRNA calls the workroom and states, my vaporizer is set to 2% and my analyzer says the inspired agent concentration is 1.2%; please help! Debbie from the workroom replaces the vaporizer and the gas monitor but the scenario does not change. Debbie calls Biomed for help!**

**Scenario:**





## VAPORIZER Troubleshooting

Casey from Biomed asks what is the Fresh Gas Flow (FGF) of the anesthesia system. Once he hears the clinician is using low flow anesthesia, he suspects the Dilution Effect of Rebreathing is going on. He explains:

Minute Volume is composed of FGF and the recirculated gases of the exhaled breath.

If FGF is high, it constitutes a larger share of the MV. Fresh gas contains full agent concentration. The gas analyzer reads accurately and matches the vap setting.

As FGF is reduced, more recirculated gas comprises the MV. Recirculated gas contains diluted agent concentrations and dilutes the overall inhaled concentration. The gas analyzer reads accurately but lower than expected.

## *Clinical Focus*

*by Datex-Ohmeda*

### **The Dilution Effect of Rebreathing**

My vaporizer says 2%.

My analyzer says the inspired agent  
concentration is 1.2%.

Guest Editor

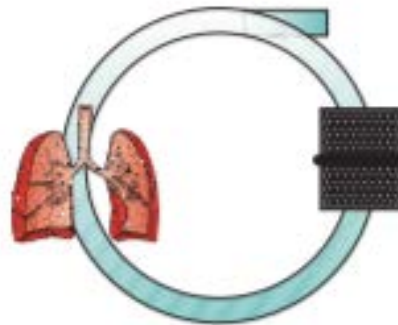
**James H. Phillip, MEE, MD**

Anesthesiologist:

Brigham and Women's Hospital, Boston, MA

Associate Professor of Anesthesia:

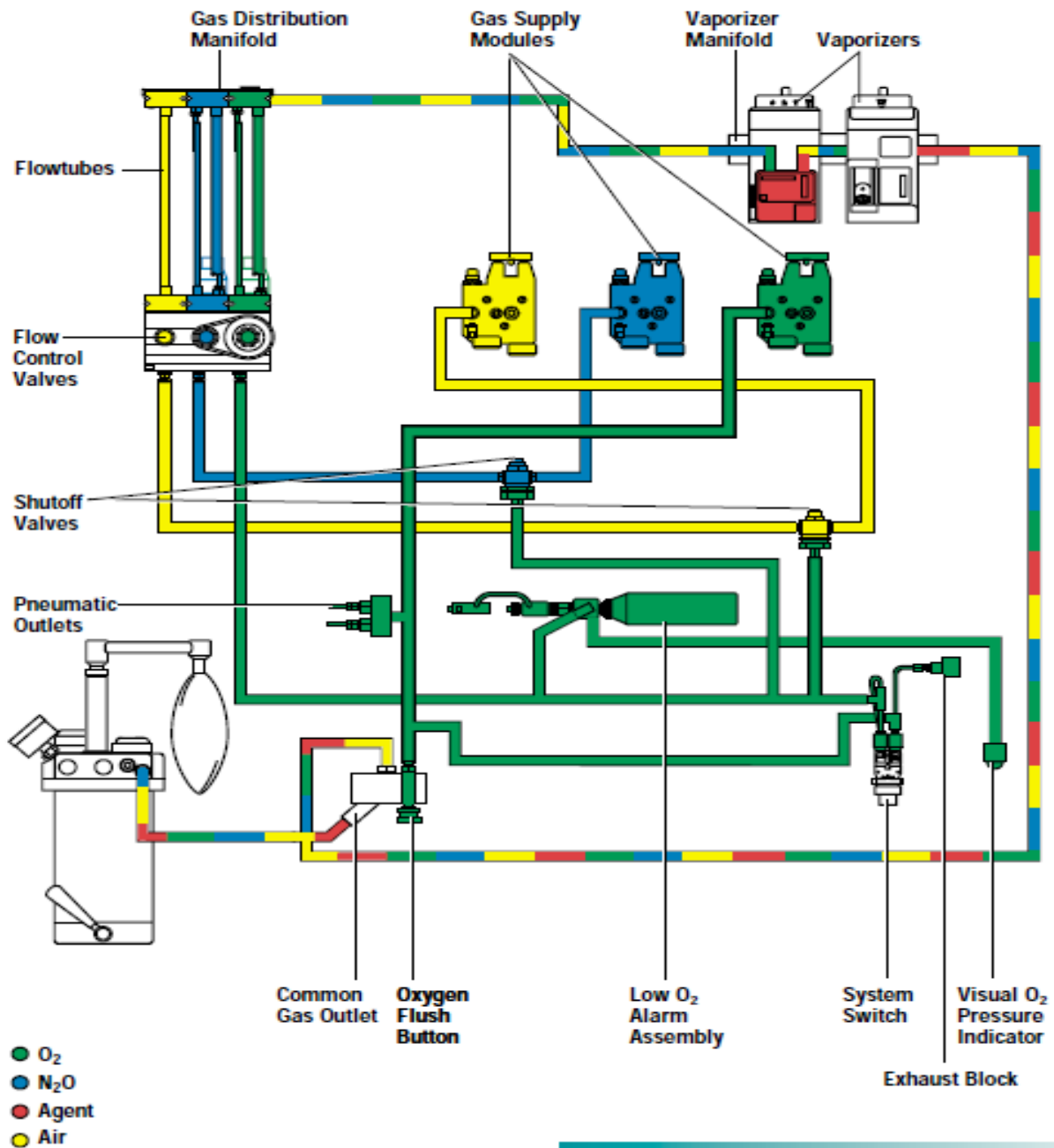
Harvard Medical School, Boston, MA



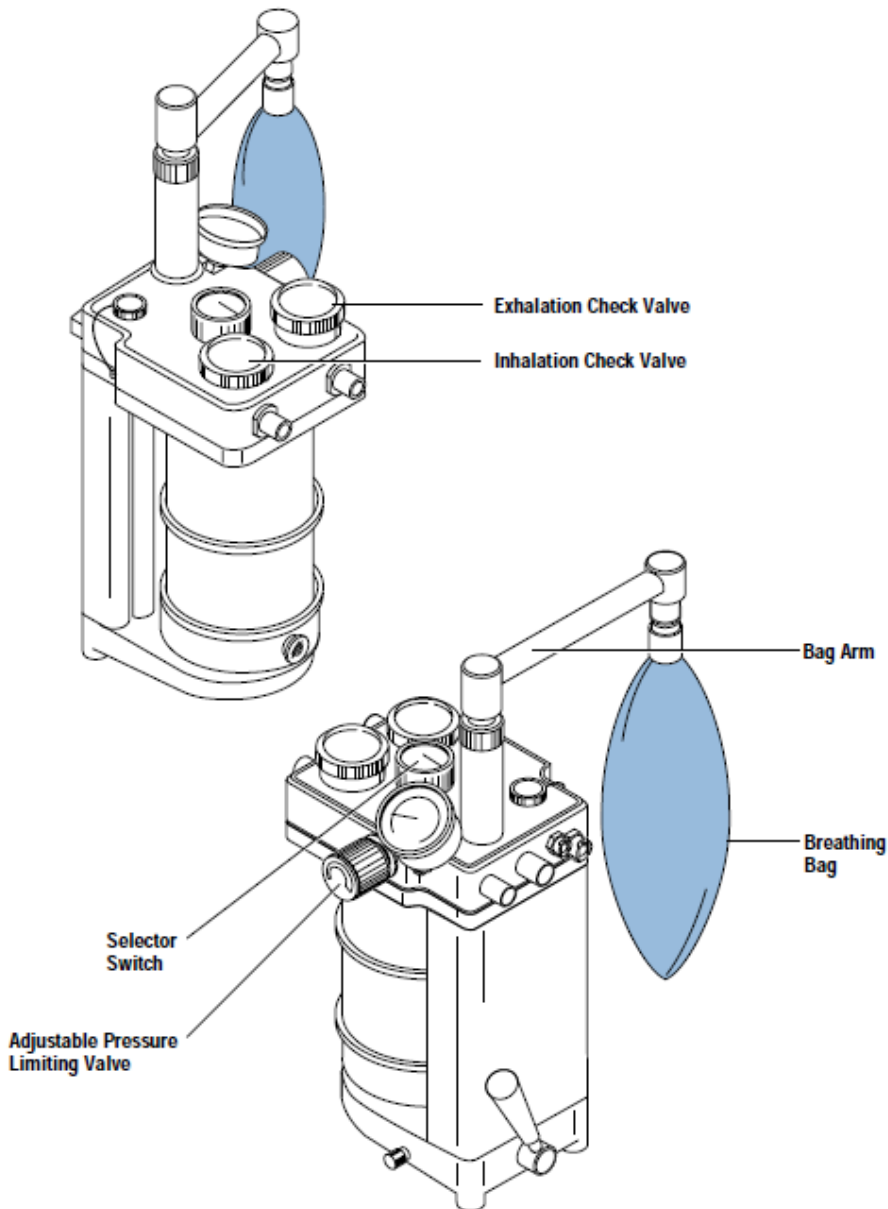
From the Breathing System Series

Illustration 6

Gas flow through the anesthesia machine



The GMS absorber



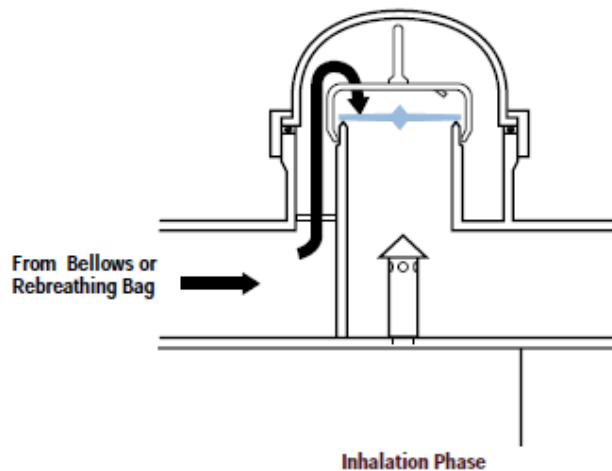
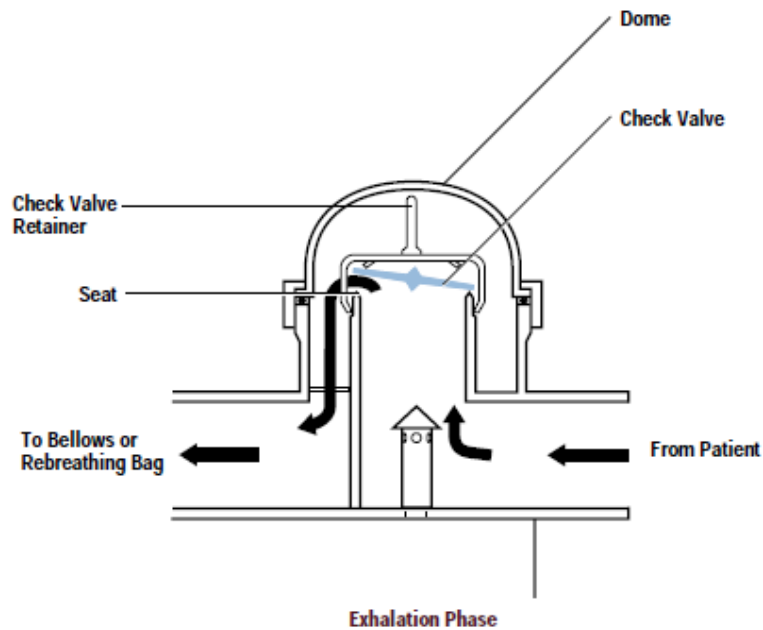
The Absorber

7-7

## CO<sub>2</sub> Absorber:

- Absorbent granules remove the CO<sub>2</sub> from the patient's exhaled gas.
- Facilitates either Manual (bag) or Automatic (vent) ventilation.
- Provides a port for patient O<sub>2</sub> monitoring.
- Controls airway pressure in Manual mode.
- 22 mm circuit fittings

Flow through the exhalation check valve



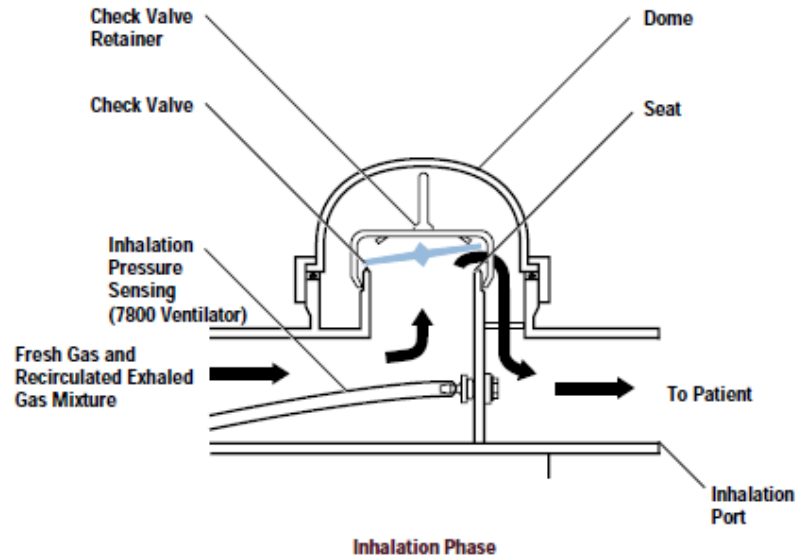
- O<sub>2</sub>
- N<sub>2</sub>O
- Agent
- Air

## Unidirectional Valves:

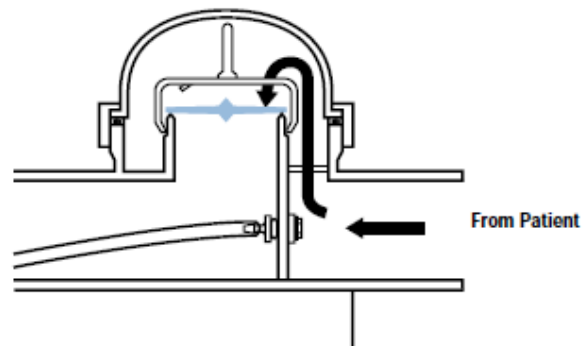
- Prevents rebreathing of CO<sub>2</sub>
- Seat / Disc design ensures one-way flow.
- Clear domes allow visual inspection of discs.
- Excess water contamination on disc could cause reverse flow.

Illustration 70

Flow through the inhalation check valve



Inhalation Phase



Exhalation Phase

- O<sub>2</sub>
- N<sub>2</sub>O
- Agent
- Air

## Scenario:

Dr. Law and Michael Boulton, CRNA, are working in OR1 at Uniontown. After intubation, the patient and the machine were moved and positioned for the procedure; now the ventilator bellows is struggling to refill during expiration. FGF is 4 lpm. What can they do?



# Check for leaks in the breathing system:

- ET Tube position.
- Breathing circuit connections.
- Absorber fittings and connections:

O<sub>2</sub> sensor

Airway pressure lines

- Ventilator connections

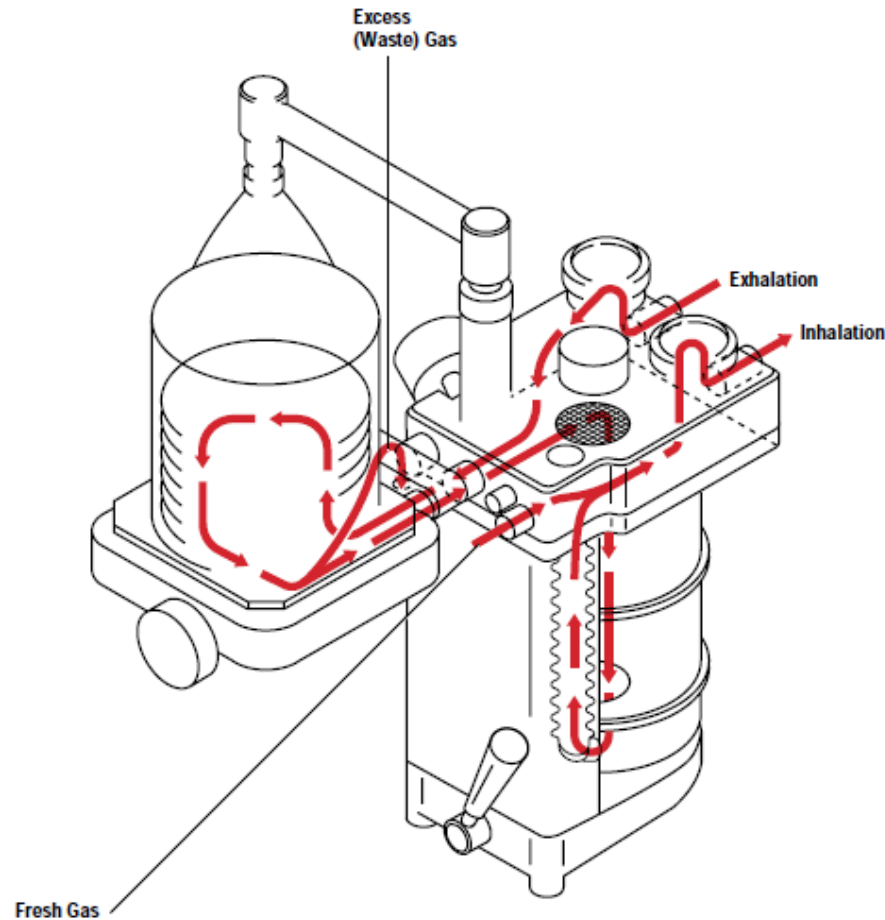


### **Answer:**

**Turns out, the clear observation dome on the absorbers inspiratory check valve was cracked when the machine was moved. Dr. Law replaced the dome to restore proper, leak free operation.**

Illustration 73

Gas flow through the absorber with the selector switch set to ventilator.

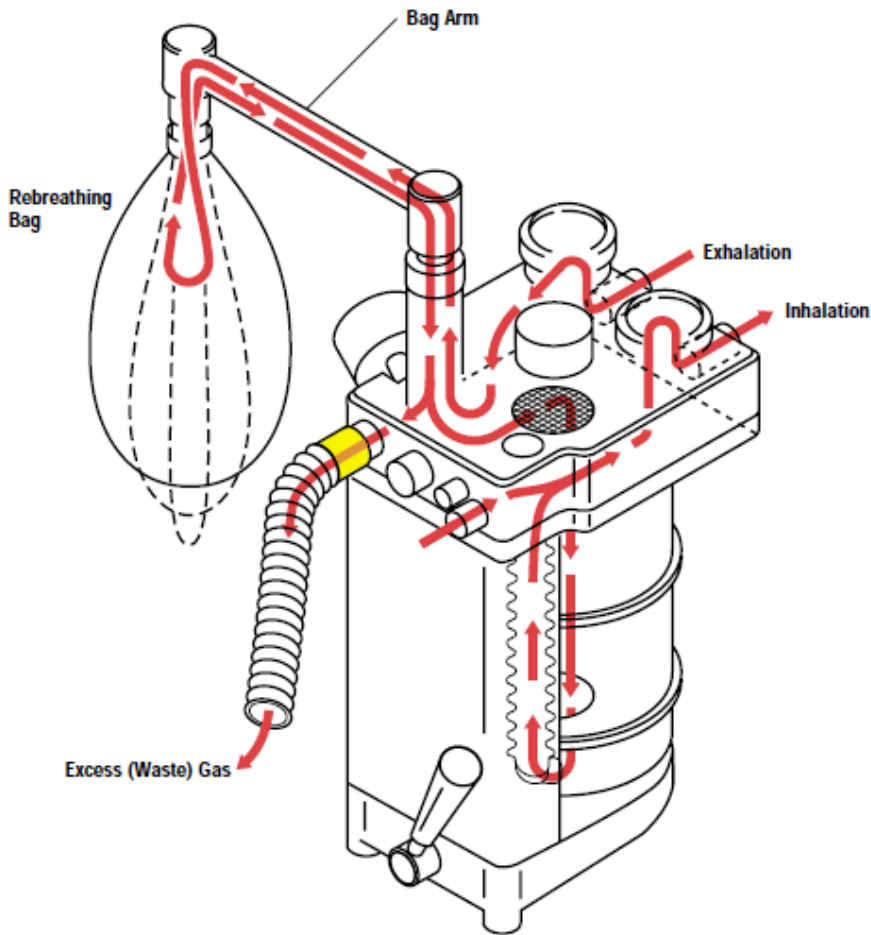


## Automatic Vent Mode:

1. Exhaled gas is routed to ventilator bellows.
2. When the vent cycles, the exhaled gas is forced down through the absorbent granules.
3. Patient rebreathes a scrubbed gas / fresh gas mixture.

Illustration 74

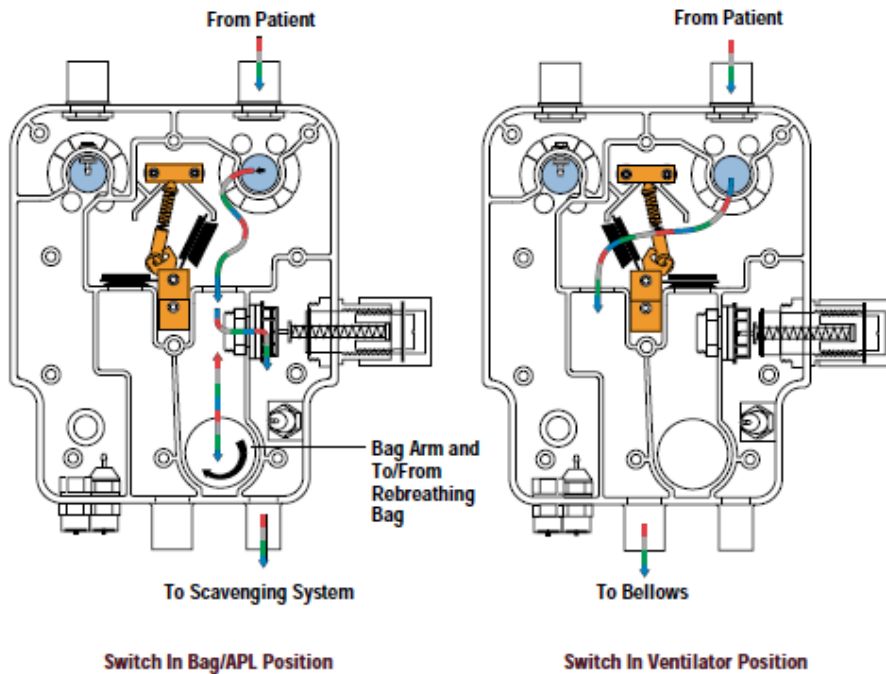
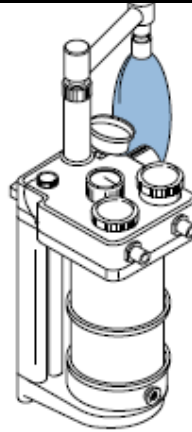
Gas flow through the absorber with the selector switch set to Bag-APL.



## Manual Bag Mode:

1. Exhaled gas is routed to breathing bag.
2. When bag is compressed, the exhaled gas is forced down through the absorbent granules.
3. Excess gas is diverted to waste system via APL.
4. Patient rebreath a scrubbed / fresh

The selector switch (underside view)



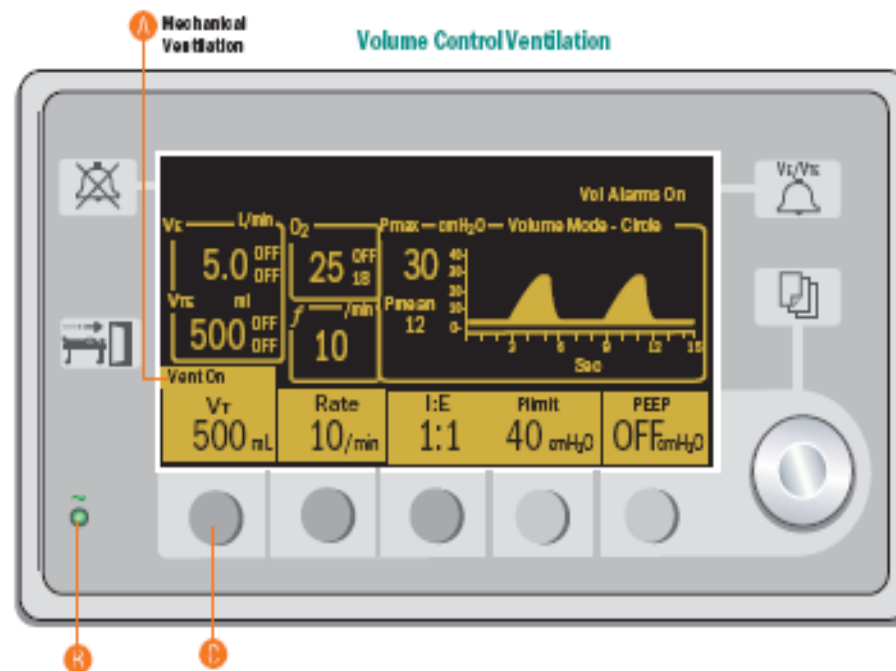
- O<sub>2</sub>
- N<sub>2</sub>O
- Agent
- Air

## Circuit Selector Switch:

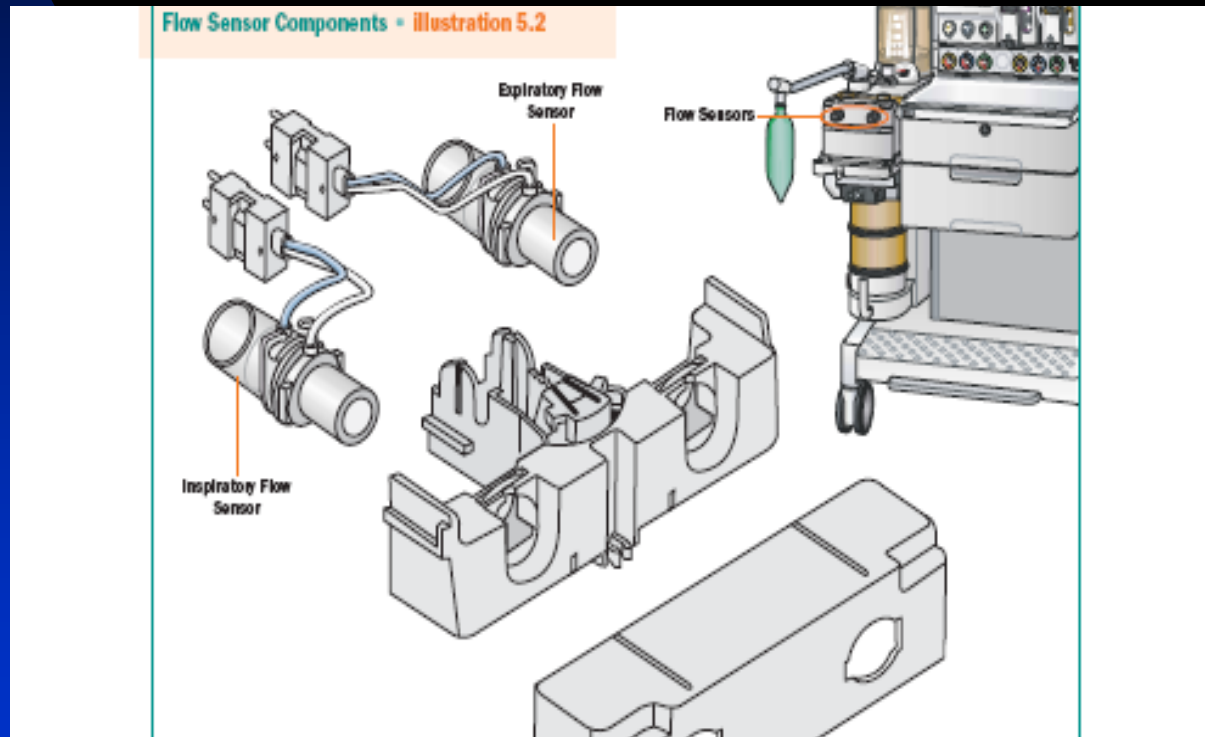
- In Bag mode, exhaled gas is routed to breathing bag.
- The Adjustable Pressure Limiting (APL) valve limits airway pressure to ~ 70 cmH<sub>2</sub>O in bag mode.
- In Vent mode, excess gas is routed to the ventilator bellows.

# The Datex-Ohmeda 7900 Ventilator

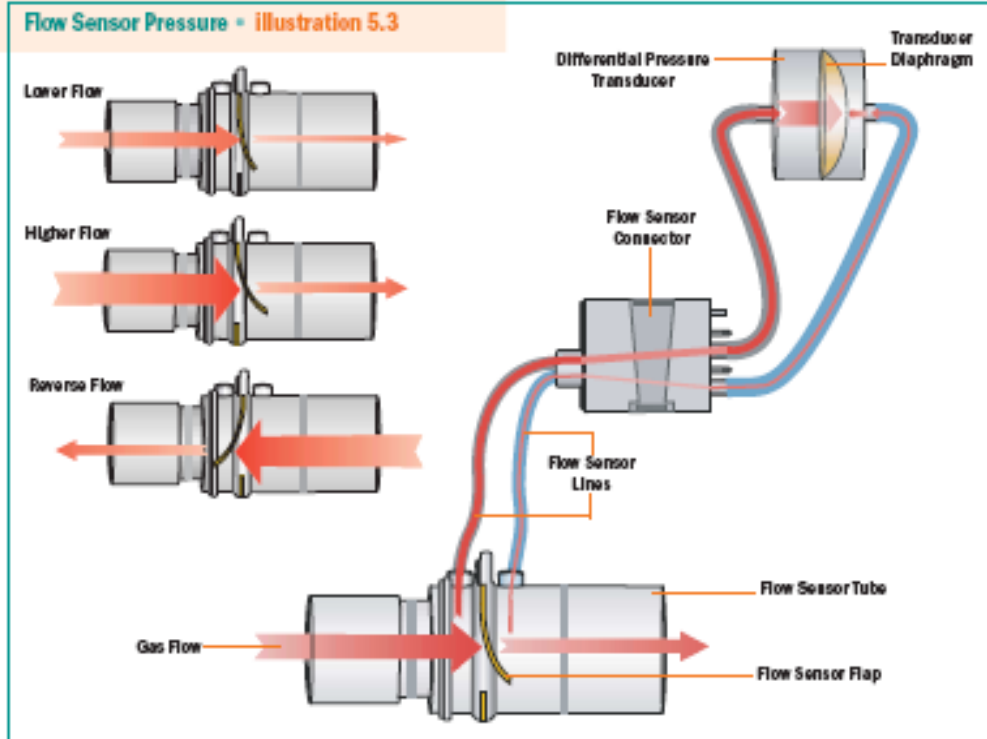
Display Components - illustration 7.3



# The 7900 Ventilator uses innovative Flow Sensor Technology



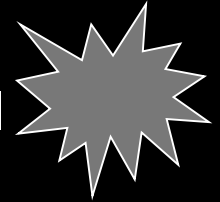
# More than just a hollow tube !!!



5.5



The Flow Sensor's provide feedback to the control circuitry of the 7900 ventilator. This feedback allows the ventilator to:



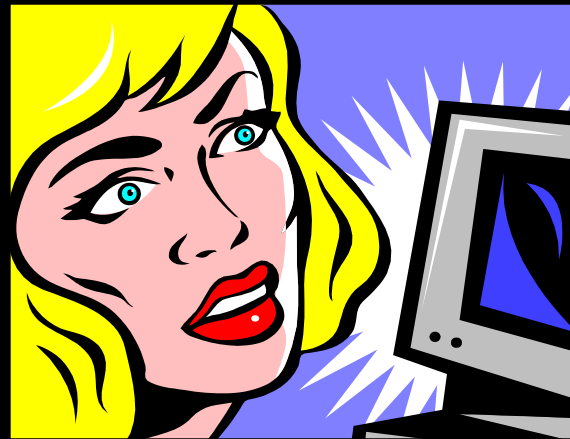
1. **Compensate for Absorber Compliance losses**
2. **Compensate for changes in Fresh Gas Flow**
3. **Compensate for Oxygen Flush**
4. **Detect Flow direction**
5. **Monitor ventilator and patient activity to drive alarms**

**WOW !!**



## Scenario:

Pat Hill, CRNA, is working in OR 3 at Frick Hospital. The OR is equipped with a GE Avance/7900 anesthesia system. Pat has a TV of 700ml set but the Delivered TV is showing about 600ml. Pat is confident she knows what to do.



## Pat calibrates the flow sensors to solve the problem.

3 User Maintenance

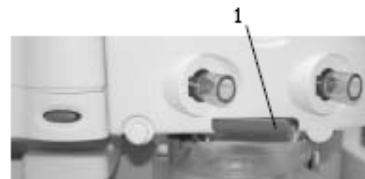
### Flow sensor zeroing

**⚠WARNING** Do not perform calibration while unit is connected to a patient.

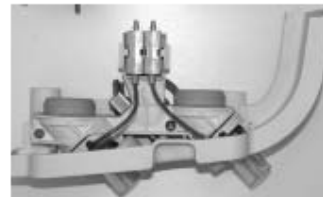
The system automatically corrects for zero offset when you unplug the flow sensor connectors with power on. You must stop mechanical ventilation before you calibrate the flow sensors.

Note: Properly performing the O<sub>2</sub> cell zeroing will also zero the flow sensor.

**Step 1**  
Pull the latch (1) to unlock the flow sensor module from the breathing system.



**Step 2**  
Pull the flow sensor module from the breathing system.



**Step 3**  
When zeroing is complete, the screen shows, "No Insp flow sensor" and "No Exp flow sensor."

**No Insp Flow Sensor**  
**No Exp Flow Sensor**

**Step 4**  
Install the flow sensor module.

**Step 5**  
Do a breathing circuit leak test before using the system. Refer to "Breathing system tests" in section 4 *Preoperative Tests* of the User Reference Manual, Part 1.

## Scenario:

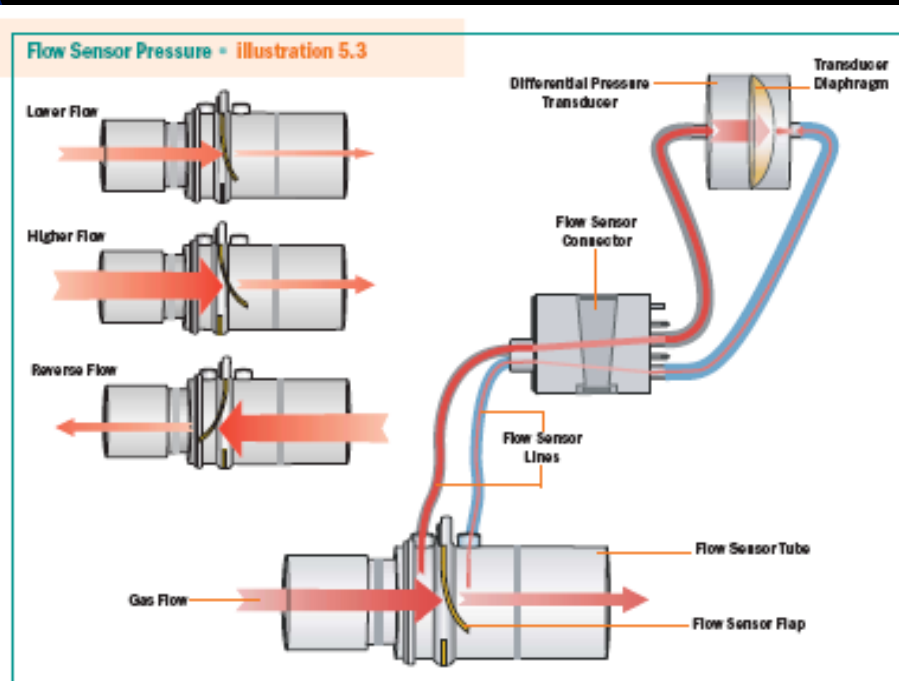
Today, Pat Hill, CRNA, is working in OR 2 at Frick Hospital. The OR is equipped with an Aestiva/7900 anesthesia system. In the middle of a case, the ventilator begins to alarm “Expiratory Reverse Flow.” Pat is confident she knows what to do.



## Ventilator / Absorber Troubleshooting

Pat replaces the expiratory flow sensor to solve the problem. She notices that there is not a lot of water in the flow sensor which can also cause the alarm. Nancy visualizes the flow sensor and how it works; she wonders if a leaking flow sensor line could have been the problem.

Question: Could she be right?



## MYSTERY Troubleshooting ????????

Dr. Carl is working in OR 5 during an open heart procedure. OR 5 is small for an open heart room so things are packed in tight. During the case, Dr. Carl moves the anesthesia machine around to make room for the TEE system. Shortly after, Dr. Carl notices that 7 cm of PEEP is being displayed on the pressure gauge. Dr.

Carl can not determine what is causing the unintentional PEEP and asks the attending CRNA for some troubleshooting help. You jump into action!



Scenario:

## SCAVENGER Troubleshooting

### **Question:**

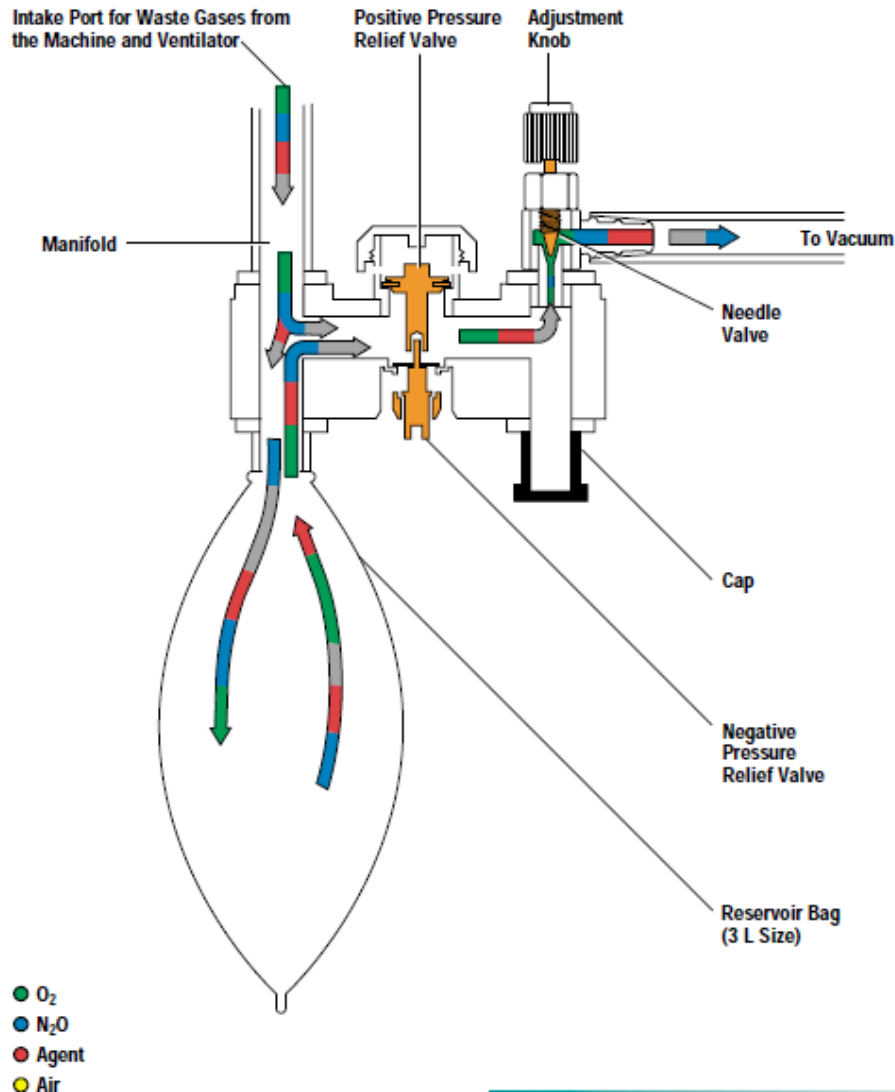
**You notice that the reservoir bag on the scavenging system is ballooned out and that one of the machines wheels is sitting right on top of the scavenger output hose. You move the machine and clear the hose and the problem is resolved. Why did the PEEP only reach 7 cmH<sub>2</sub>O; what prevented it from going any higher?**

## SCAVENGER Troubleshooting

### Answer:

The scavenger interface valve has a built in positive relief valve that will relieve at a pressure of approx. 5 cmH<sub>2</sub>O should the outlet tube become kinked or if the vacuum is lost. As the pressure in the reservoir bag begins to build, the positive relief valve will open up.

The waste gas scavenging valve active system



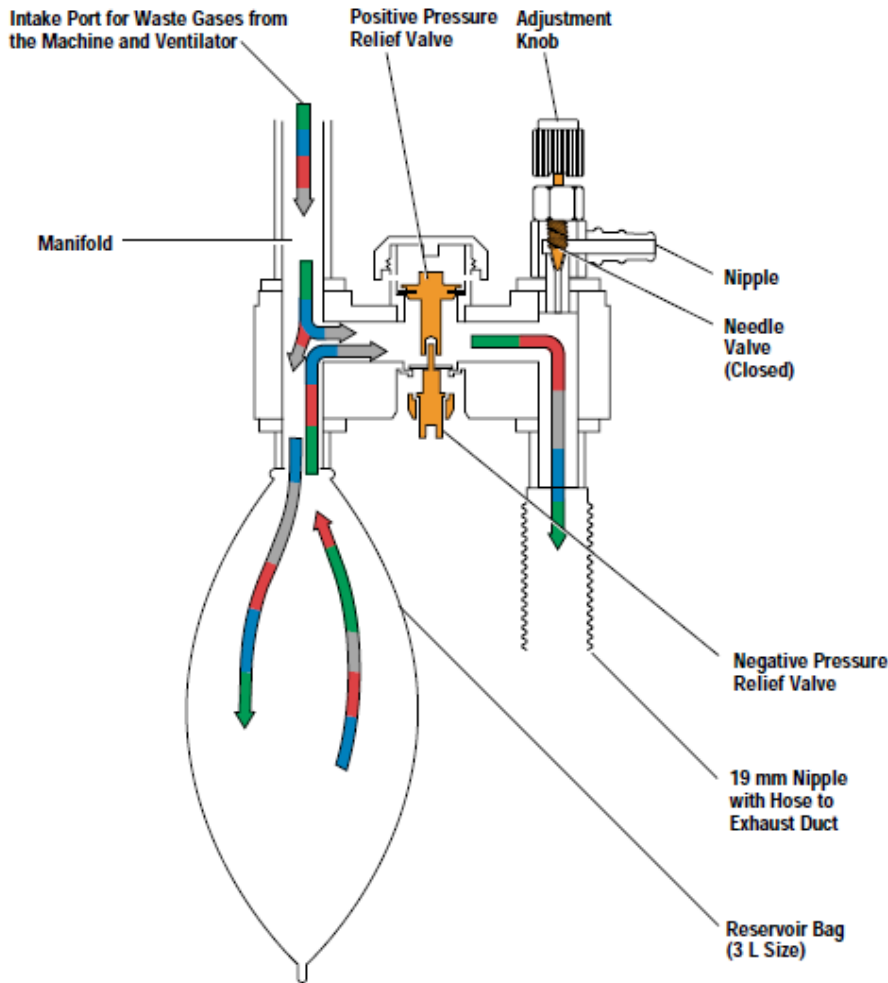
## Waste Gas Scavenging System:

- Offers multiple 19 mm intake ports.
- Connects to facilities waste gas system; active or passive.
- Reservoir bag offers visual indicator.
- Prevents barotrauma via pressure relief valves. ~ 5 cmH<sub>2</sub>O positive, .25 cmH<sub>2</sub>O negative.



Figure 78

Waste gas interface valve passive system



- O<sub>2</sub>
- N<sub>2</sub>O
- Agent
- Air

## Waste Gas Scavenging System:

- Controls exposure to waste anesthetic gases. NIOSH recommends limiting N<sub>2</sub>O exposure to 25 ppm.
- Popular spot for disconnects and occlusions.

# Summary of Required components of an Anesthesia system:

## Discussed:

- ✓ Cylinder supplies
- ✓ Pipeline supplies
- ✓ Flow-meters
- ✓ O2 Flush
- ✓ Breathing circuit pressure limited
- ✓ Various monitors
- ✓ Vaporizers
- ✓ Only one Common Gas Outlet

## Not Discussed:

- ✓ Battery back-up
- ✓ Grouped alarms
- ✓ Pre-op Check-list
- ✓ Digital Interface

**Question:**

**Several items on Datex-Ohmeda machines are autoclavable. How can you determine what parts are?**

**Answer: The parts are marked with “134 degrees C”**

**Question:**

**What does the Pro in PSVPro stand for?**

**Answer: Protection, as in apnea backup protection.**

# QUESTIONS?



# Thank You

## References

Kolek, Bob and Janice Rice.  
Explore, the Anesthesia System.  
1996 ed.

Wabiszewski, Jodi. Explore, the  
Anesthesia System – Aestiva 5.  
2005 ed.