

TruaCut

PRODUCTS BY
RICHARD STANLEY PTY. LTD.



Product Catalogue 2018



Router Bits



Router Bit Merchandiser

- Easy stock control
- Product sits neatly on Clear Perspex shelves
- Sliding lockable doors
- Fluoro Header
- Price bar spacing above each product
- Ability to display wide product range neatly
- Clear vision
- Full product description and bar code label.
- Plinth on bottom of Double and Triple Merchandisers

SINGLE 83Pc Merchandiser (932 x 632 x 200mm)
 Plus Fluoro Header (155mm)

DOUBLE 152Pc Merchandiser (932 x 1505 x 200mm)
 Plus Fluoro Header (155mm)

TRIPLE 220Pc Merchandiser (932 x 2137 x 200mm)
 Plus Fluoro Header (155mm)



Accessories Page

Arbors/Ball Bearings/Keys	
/Screws/Washers	21
Diamond Router Bits / Heads	

Edge & Face Forming-Top Bearing

Classical Plunge-Top Bearing	10
Core Box-Top Bearing	10
Inverted Flush Trim	10
Provincial Plunge-Top Bearing	10
V Lettering-Top Bearing	10

Edge & Face Forming Bits

Bead & Flute Bit-Roll Top Desk	14
Beading -Broad Point	9
Beading-Wide Point	9
Core Box Bit	9
Dish Carving Bits	14
Ogee-Fine Point	14
Ogee-Standard Point	14
Ogee-Wide Point	14
Surface Classical-Round Nose	9
Triple Surface Beading Bit	11
Triple Surface Flute Bit	11
V Grooving Bits	9
Veining Bits	9

Edge Forming Bits

Beading Bits	7
Bull Nose Radius Bits	8
Chamfering Bits	6
Classical Bits	8
Cove Bits	6
Ogee Bits - with top fillet	6
Provincial Bits	8
Rabbeting Bits	6
Rabbeting Bit-Set	6
Roman Ogee Bits	8
Rounding Over Bits	7

Edge Forming -Table Edge Bits

60' Chamfer/Steep S Mould	12
Indent Ogee/Sml Full Bead	12
Table Edge with Return	12
Low Roman Ogee / Lge Bead	12

Face Moulding Bits Page

Bead/Low S with Plinth Face Mould	13
Bead/Shallow Surface Concave	13
Deep Federation Face Mould	13
Flat Classical Face Mould	13
Short Classical Face Mould	13

Flush Trim Bits Page

22' Bevel/ Straight Trim	11
30' Bevel Trim	11
Straight Flush Trim	11
Down Shear Trim Bits	10&11

Groove Forming Bits

Ball / Rope Track Bits	15
Dovetail Bits	15
Hook Slot/ Picture Hangers	15
Slotting Cutters	20

Hand Rail Bits - Side & Top 18

Jointing Bits

Biscuit Cutter (4mm Slotting)	20
Dovetail Bits	15
Draw Pull Bit	19
Finger Joint Set	20
Mitre Lock Bits	19
Tongue & Groove Set	19
Window Sash Cutter Set	19

Panel Door- Stack System

Rail & Stile - Classic/Ogee/Trad'al	17
-------------------------------------	----

Raised Panel Bits

25' Raised Panel Bit	16
Flat Double Ogee Raised Panel B	14
Low Profile Ogee Raised Panel Bit	14
Shallow Double Cove Raised Panel	14

Straight Bits

Straight Bits-single flute	4
Straight Bits-two flutes 6.4mm shk	4
Straight Bits-two flutes 12.7mm Shk	5

Multisaw & 82mm Planner Blades 22

PCD Compressed Firbe cement

Saw Blades 27

Jigsawblades 28

Recipro Blades 29

Router Bit Terminology

T	- Tungsten Carbide Tipped or Solid	eg TB516
B	- Ball Bearing	eg TB516
M	- Width of the bit is metric size	eg TM216 (16mm)
X	- Extra long cut,	eg TMX1416
XX	- Extra Extra long Cut,	eg TBXX8016/2
/2	- The shank of the bit is 1/2 (12.7mm)	eg TB524/2
& if not specified the shank is 1/4 (6.35mm)		
Other letters in the Product # generally describe the bit		
is T ungsten carbide B all bearing P anel D oor S tack system		
# 10 with 1/2 (12.7mm) shank.		
		eg TBPDS10/2

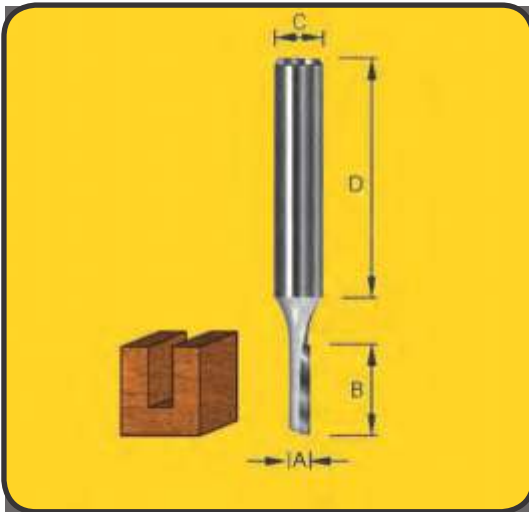

Straight - Single flute

(1/4") 6.35 x 32mm shank

Product #	A mm	B mm
TM202	2.0	4.8
TM203.2	3.2	9.5
TM204	4.0	12.7
TM205	5.0	12.7
TM206	6.0	19.0
TM203.2SC	3.2	9.5 Solid Carbide Insert
TM204SC	4.0	10.0 Solid Carbide Insert
TM205SC	5.0	12.7 Solid Carbide Insert
TM206SC	6.0	16.0 Solid Carbide Insert 2F

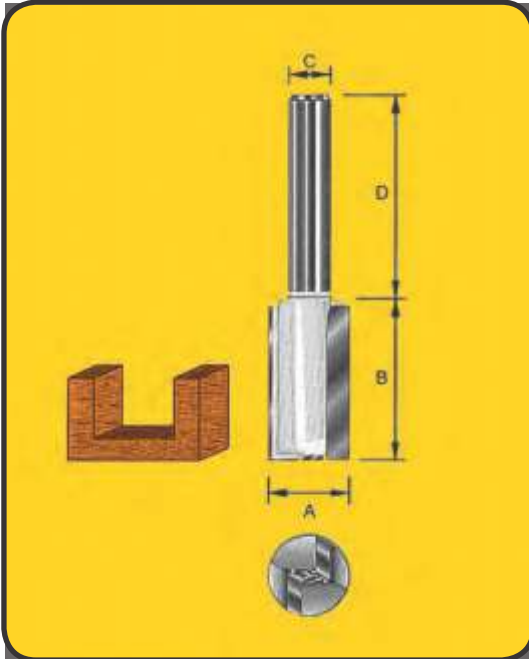

Straight - Two flutes

(1/4") 6.35 x 32mm shank

Double flute bits are recommended for general routing, grooving and rebating etc. Bottom of the bit is ground for general plunging then normal side cutting.

Product #	A mm	B mm
TM206.4	6.4	19.0
TMX206.4	6.4	25.4
TM207	7.0	19.0
TM208	8.0	19.0
TMX208	8.0	25.4
TM209	9.0	19.0
TM210	10.0	19.0
TMX210	10.0	25.4
TMX210HP	10.0	30.0 High Performance
TMX212.7	12.7	25.4
TM212	12.0	19.0
TM213	13.0	19.0
TM216	16.0	19.0
TM216.5	16.5	19.0
TM218	18.0	19.0
TM219	19.0	19.0
TM220	20.0	19.0
TM225	25.0	19.0
TM216EC	16.0	
TM219EC	19.0	
TM222EC	22.0	
TM225EC	25.0	
TM228EC	28	
TM233EC	33	

Tungsten carbide
 END CUTTING tip designed
 for mortise lock plung jigs.

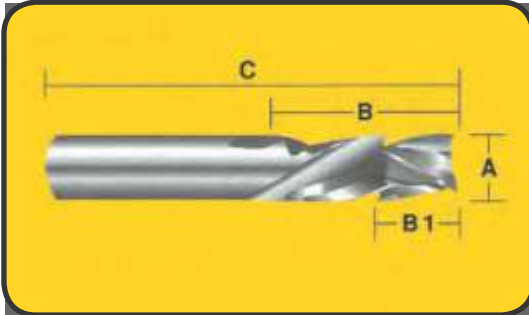

Compression Bit

Down and upcut spiral prevents chipping top and bottom surface

Product #	A mm	B mm	B1 mm	C mm
TM2FCB22-6.4	6.4	22	8	65

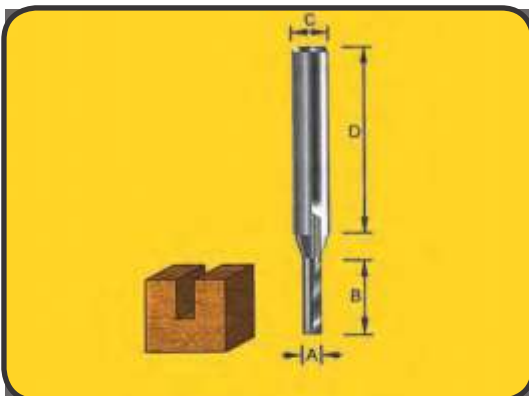

Straight-Solid insert - Two Flutes

(1/4") 6.35 x 32 mm shank

Solid tungsten carbide slug ground and inserted into a steel shank.

Product #	A mm	B mm	O/Lth
TM1803.2	3.2	10	55.0
TM1804	4.0	10	55.0
TM1805	5.0	16.0	60.0
TM1806.4	6.4	20.0	65.0

Straight - Two flutes

(1/2") 12.7 x 38mm shank Used for general routing, grooving etc. Bottom of the bit is ground for general plunging then normal side cutting. Remember that a 1/2" shk bit is no stronger than of the narrowest section of the bit. eg. A 6mm dia. TM1406 (1/2"shk) bit is generally no stronger than the same size with 1/4" shank. Extra long cut bits (X/L cut) are ideal for use in Router benches when trimming or planing the edge of timber instead of using your power plane. This planing method makes sure you plane your job square to the main surface.

Product #	A mm	B mm	
TM1406	6.0	19.0	
TM1406.4	6.4	19.0	
TM1408	8.0	25.4	
TM1409	9.0	25.4	
TM1409.5	9.5	25.4	
TM1410	10.0	25.4	
TM1410HP	10.0	30.0	High Performance
TM1411	11.0	25.4	
TM1412	12.0	32.0	
TM1412HP	12.0	30.0	High Performance
TM1412.7	12.7	32.0	
TM1412.7HP	12.7	30.0	High Performance
TMX1412.7	12.7	50.8	X/L cut
TMXX1412.7	12.7	63	X/L cut
TMXXX1412.7	12.7	76.0	X/L cut
TM1413	13.0	32.0	
TMX1413	13.0	50.8	X/L cut
TM1414	14.0	32.0	
TM1415	15.0	32.0	
TM1416	16.0	32.0	
TMX1416	16.0	50.8	X/L cut
TM1416.5	16.5	38.0	
TM1417	17.0	38.0	
TM1417.5	17.5	38.0	
TM1418	18.0	38.0	
TMX1418	18.0	50.8	X/L cut
TM1418.5	18.5	38.0	
TM1419	19.0	38.0	
TMX1419	19.0	50.8	X/L cut
TM1419.5	19.5	32.0	
TM1420	20.0	32.0	
TM1425	25.0	38.0	
TM1428.5	28.5	32.0	
TM1432	32.0	32.0	
TM1438	38.0	38.0	

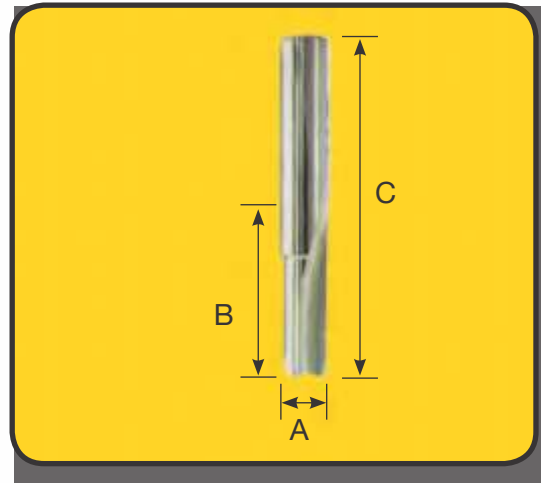
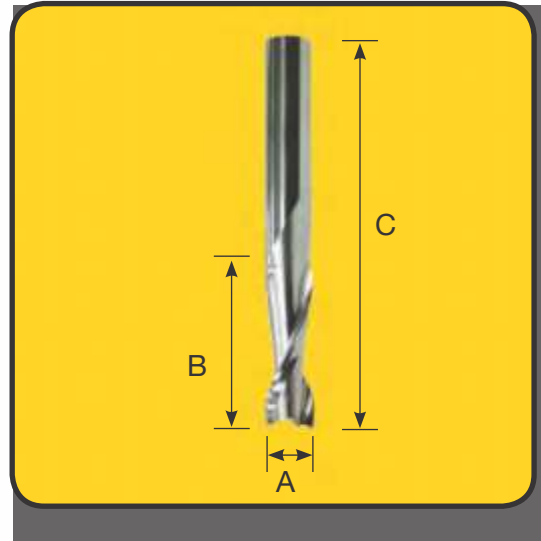
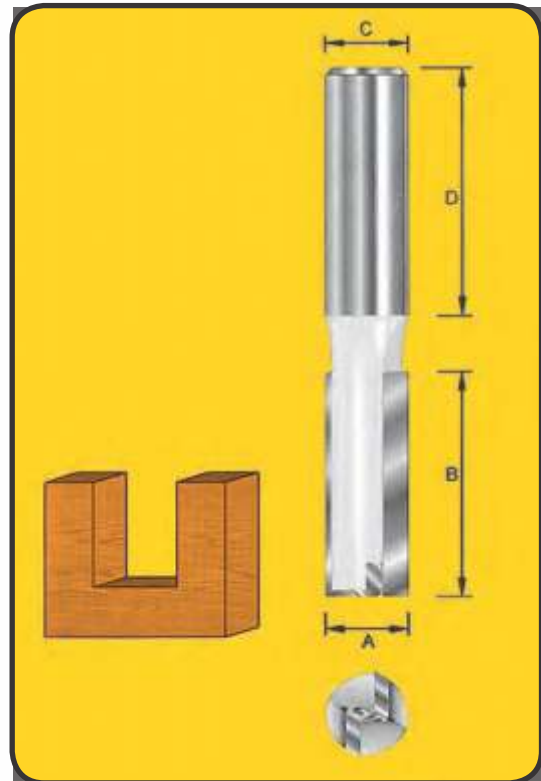

For NON Ferrous Metals

Aluminium cutting solid tungsten carbide right hand up cut spiral - two flute

Product #	A mm	B mm	C mm
TSR8	6.35	19	64
TSRX8	6.35	25.4	

SPOON Flute-Single

Solid tungsten carbide for cutting aluminium and some soft plastic

Product #	A mm	B mm	C mm
TSPO6	4.8	16	64

When cutting aluminium use a waxstick lubricant.

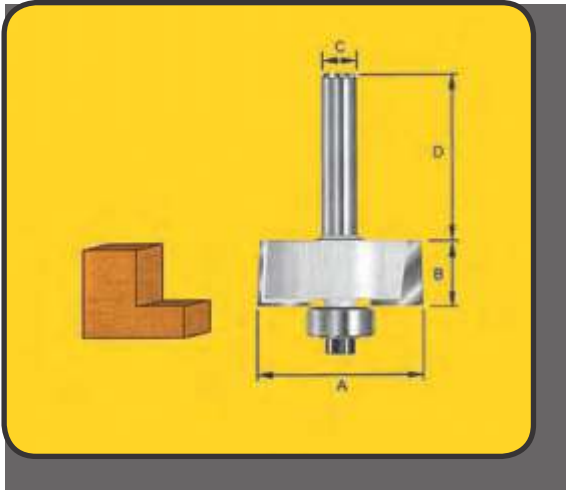

Rabbeting Bits & Sets

Rabbeting bits cut fast accurate rabbet joints which are seen in the draw front and rear inlet sections in the backs of picture and mirror

frames, door panel sections etc.

Product #	Rabbet	A mm	B mm
TB1708	6.4	31.8	12.7
TB1712	9.5	31.8	12.7

Rabbeting SET-4 sizes (1 bit) 12.7mm Shk

Product #	A mm	B mm
TB1700S/2 Sizes	34.9	12.7
8, 9.5, 11 & 12.7 of Rabbit using different bearings		

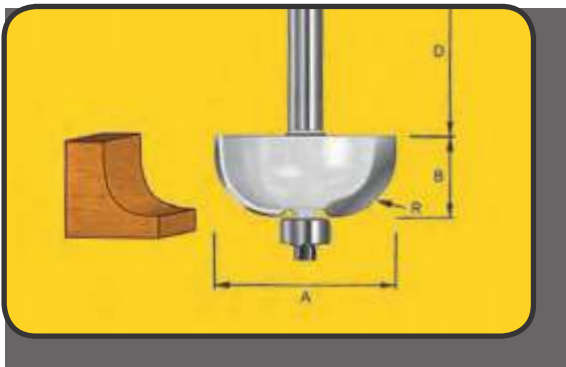

Cove Bits

Cove bits are used for decorative edging & drop leaf table joints.

Product #	Radius	A mm	B mm
TB708	6.4	22.0	12.7
TB712	9.5	28.6	12.7
TB716/2	12.7	35.0	15.9
TB720/2	16.0	44.5	19.0

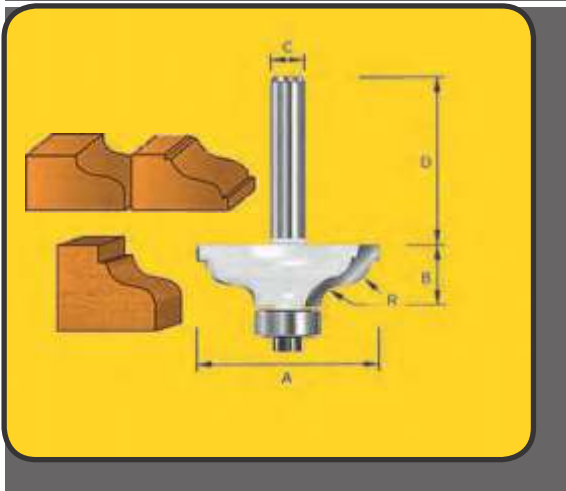

Ogee Bits- with top fillet

Traditionally the ogee bit routs through the surface of the job. These ball bearing guided bits follow the contoured edge of the job to produce three distinct professional profiles just by changing the bearing and or lowering the bit into the job surface. 1st Group Fitted with large bearing. (B105 1/2')

Product #	Radius	A mm	B mm
TB75065/2	4.8	35.0	15.0
TB75085/2	6.4	41.4	18.0
TB75125/2	9.5	54.0	25.0

Above right fitted with 3/8 B106 bearing giving a step

TB75066/2	4.8	35.0	15.0
TB75086/2	6.4	41.4	18.0
TB75126/2	9.5	54.0	25.0

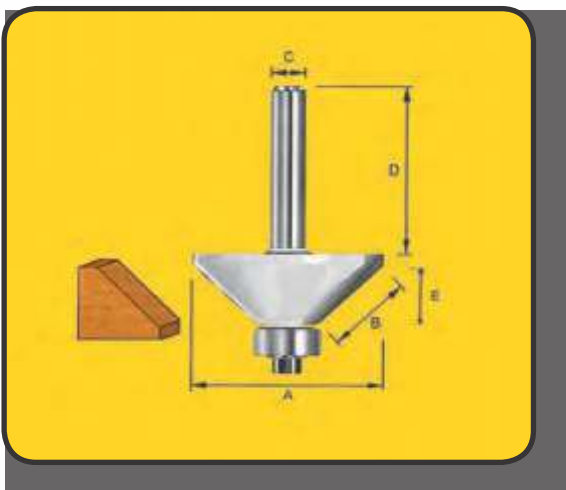

Chamfering Bits - 12.7mm Bearing

45° Chamfering bits are can be used just to break the edge or produce a full decorative cut.

By fitting a smaller bearing to this bit you can produce a step on the bottom and lower your bit into the job and produce a step on the top to.

The very large chamfering bits are used on the four corners of larger posts.

Product #	B mm	A mm	E mm
TB916	15.8	35.4	11.4
TB920/2	25.4	47.4	18.0
TB940/2	32.0	57.2	22.5

Rounding Over Bits

Rounding over bits are the most used of all the edge forming router bits. They are used for just breaking the sharp edge on a job as well as cutting decorative edging to form drop leaf joints. (Matching jointing bits are the Cove Bits.) Fitted with Mark free 12.7 x 4.8mm (B105) ball bearing guide these bits tend not to burn the work surface. The bit can also be converted into Beading bits just by changing to a smaller bearing (B106). The ball bearing fitted very close to the bottom cutting edge so as to allow full round over cut to be made with the bearing just being guided along a very narrow flat section on the bottom of the job. (the round over section just feathering out) Not many manufactures pay enough attention to this very important specification demanded by the tradesman.



All TruaCuT shaped bits have the full body Anti-Kickback design. Combined with close fitted bearings. ie. No large gap between the cutting edge & bearing.

Product #	Radius	A mm	B mm
TB502	1.6	16.0	9.5
TB503	2.0	16.0	9.5
TB504	3.2	19.0	9.5
TB505	4.0	19.0	9.5
TB506	4.8	22.0	12.7
TB508	6.4	25.0	12.7
TB510	8.0	28.0	12.7
TB510/2	8.0	28.0	12.7
TB512	9.5	32.0	16.0
TB512/2	9.5	32.0	16.0
TB516	12.7	38.0	19.0
TB516/2	12.7	38.0	19.0
TB520/2	16.0	44.0	22.0
TB524/2	19.0	51.0	25.0
TB532/2	25.4	63.0	32.0
TB540/2	32.0	76.0	32.0

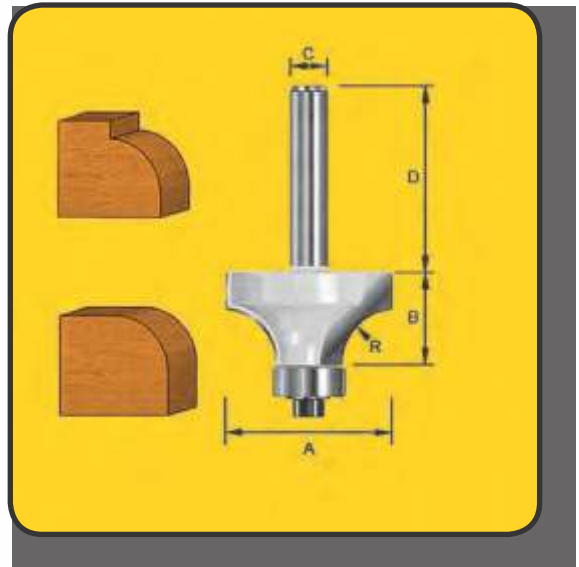

Beading Bits

The beading bit is used to produce a professional edge on the job with ease. As mentioned above these bits are very versatile as they can be either a Beading or a Rounding Over bit just by changing the size of the bearing. This makes for a very economical purchase, 2 in 1

Product #	Radius	A mm	B mm
TB604	3.2	19.0	9.5
TB606	4.8	22.0	12.7
TB608	6.4	25.0	12.7
TB610	8.0	28.0	12.7
TB612	9.5	32.0	16.0
TB612/2	9.5	32.0	16.0
TB616	12.7	38.0	19.0
TB616/2	12.7	38.0	19.0
TB620/2	16.0	44.0	22.0

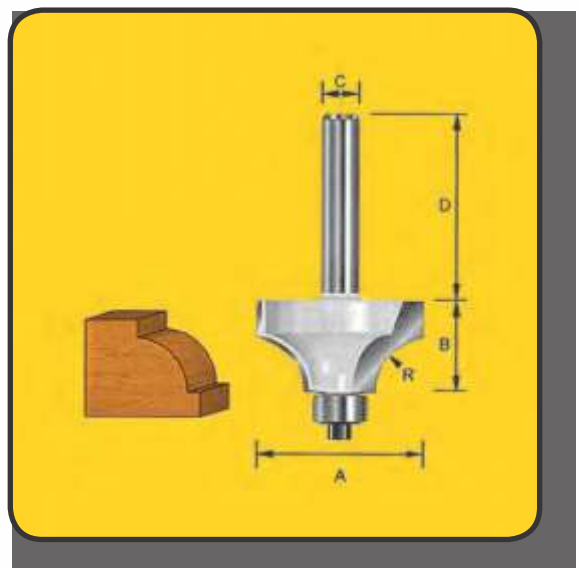

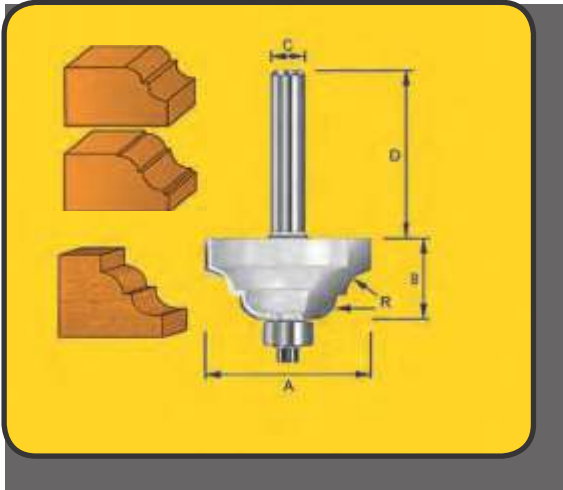

Classical Bits

These Classical bits produce a convex and concave bead with or without a step top and bottom. The changing of the bearing from large to small gives you greater versatility in cut profile.

Fitted with large bearing (B105 1/2') below

Product #	Radius	A mm	B mm
TBC85	3.2	25.4	12.7
TBC125/2	4.8	31.8	16.0
TBC165/2	6.4	38.1	19.0

Middle fitted with B106 3/8 bearing giving a step

Product #	Radius	A mm	B mm
TBC86	3.2	25.4	12.7
TBC126/2	4.8	31.8	16.0
TBC166/2	6.4	38.1	19.0

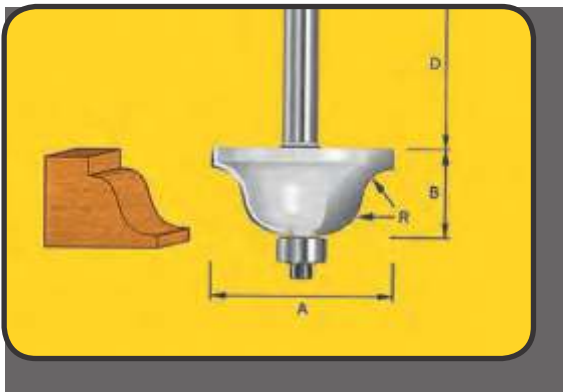

Roman Ogee Bits

The Roman Ogee bit is widely used in production of fine furniture. This bit produces a convex concave shape either with or without a step on the top edge of the job.

Product #	Radius	A mm	B mm
TB5705	4.0	30.0	12.0
TB5708	6.4	35.0	17.0
TB5708/2	6.4	35.0	17.0
TB5712/2	9.5	51.0	25.0

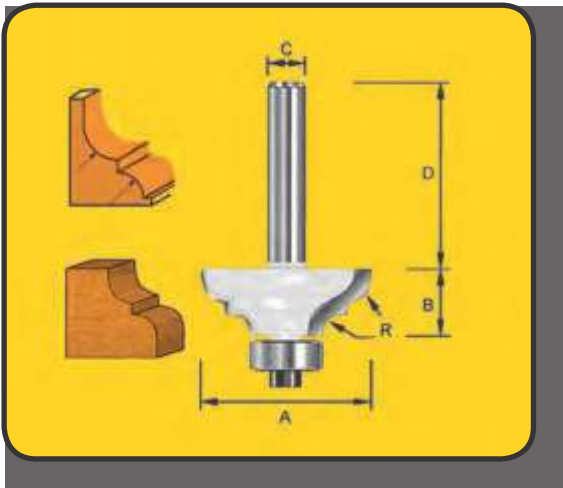

Provincial Bits

This bit produces a combination of convex step concave and step or part thereof. The 1st group no step top or bottom.

Product #	Radius	A mm	B mm
TBP85	3.2	25.4	12.7
TBP125/2	4.8	32.0	14.3
TBP165/2	6.4	38.0	17.5

Below group with small bearing produces a step

TBP86	3.2	25.4	12.7
TBP126/2	4.8	32.0	14.3
TBP166/2	6.4	38.0	17.5

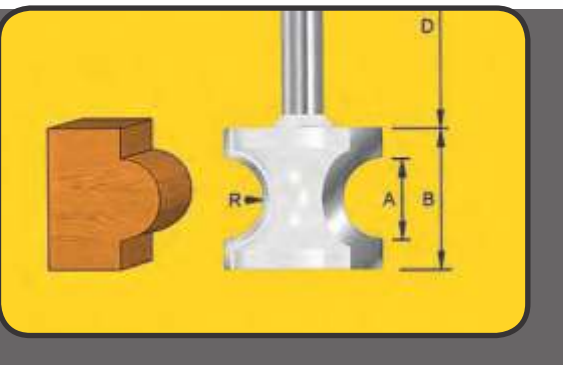

Bull Nose Radius Bits

Used to round over top and bottom of a board in one pass. Also will produce a half round bead on the edge of the job.

Product #	A mm	B mm	Radius
TBN8/2	13.5	25.0	6.5
TBN10/2	16.7	25.4	8.0
TBN12/2	19.8	28.0	9.5
TBN15/2	26.2	34.0	12.7

"V" Grooving Bits (90° & 60°)

Designed for "V" grooving cuts to replicate random groove timber panel construction, letter, sign work and general mitre joints.

Product #	mm on 45°	A mm	B mm
T112/-	7.0	9.5	4.8
T128/2	16.0	22.0	11.2
T129	22	35.0	17.5
T1230/2	26.0	39.0	19.5
T1240/2	36.0	50	25.0

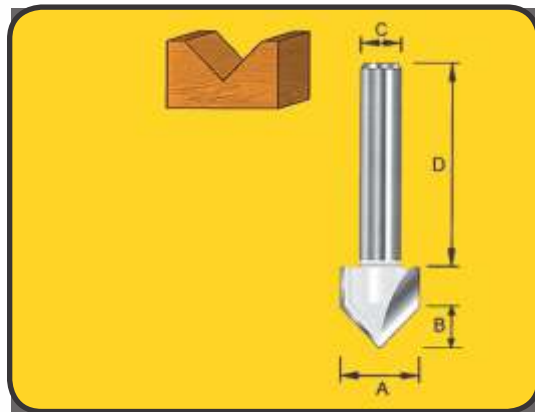

90° 45° & 135° "V" Grooving Bits for BENDING sheets of ALUCOBOND

Aluminium Composite Material & Plaster Board
 T128LB -

(4mm flat) in Alucobond Sheets

T135LB - Bit to give a 45° BEND in Alucobond sheets

T145PB - Bit to give a 135° BEND in Alucobond & PLASTER Board

T129PB - 90° Bit to give a 90° BEND in PLASTER BOARD

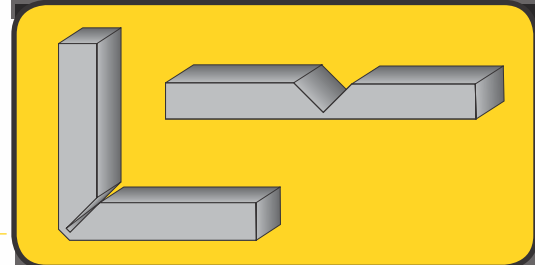

60° V Grooving Bit

Acute angled V grooving bit for fine lettering.

Product #	mm on 60°	A mm	B mm
T6128/2	23.0	25.0	21.0

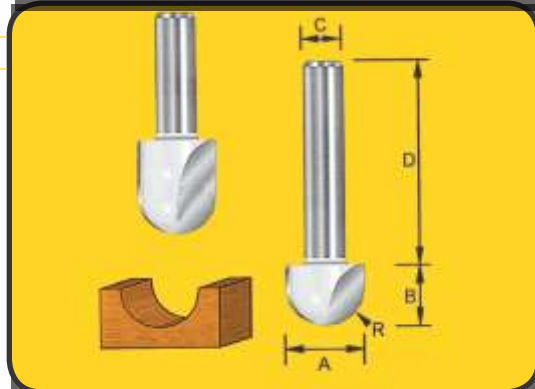

Core Box Bits / Veining Bits

Small dia. bits are called Veining bits which cut shallow grooves on board surface.

6mm wide and over are called Core Box bits.

These are used for reeding, fluting and lettering.

Product #	A mm	B mm	
T304/-	3.2	8.0	s/f
T306/-	4.8	8.0	s/f
T408/-	6.4	6.4	
T412/-	9.5	9.5	
T416/-	12.7	9.5	
T416DC	12.7	25	
T424/-	19.0	16.0	
T242DC	19	32	
T432/2	25.4	16.0	

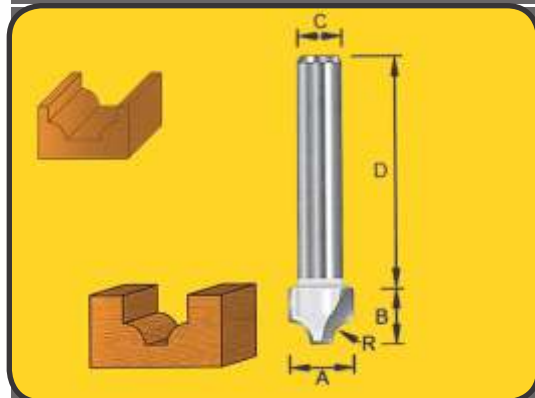

Broad/Wide Point Beading

Can plunge and cut into the surface.

Prod#	Point mm	Radius	A mm	B mm
TBB4/-	3.2mm	3.2	9.5	9.5
TBB8/2	3.2mm	6.4	16.0	12.7
TBW4/2	12.7mm	3.2	19.0	11.1
TBW8/2	12.7	6.4	25.4	19.0

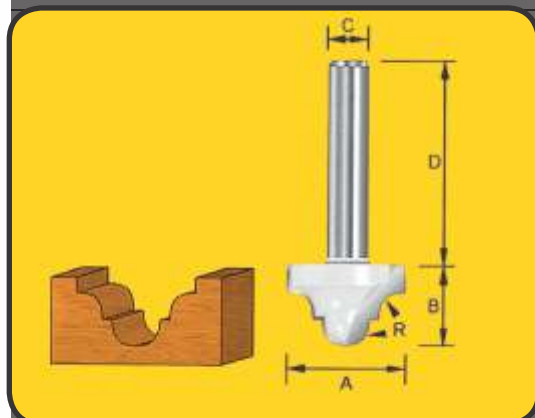

Surface Classical-Rnd Nose

Plunge cutting decorative face working bits.

Product #	Radius	A mm	B mm
TC6/	2.4	12.7	9.5
TC10/	4.0	19.0	12.7
TC12/2	5.5	25.4	16.0

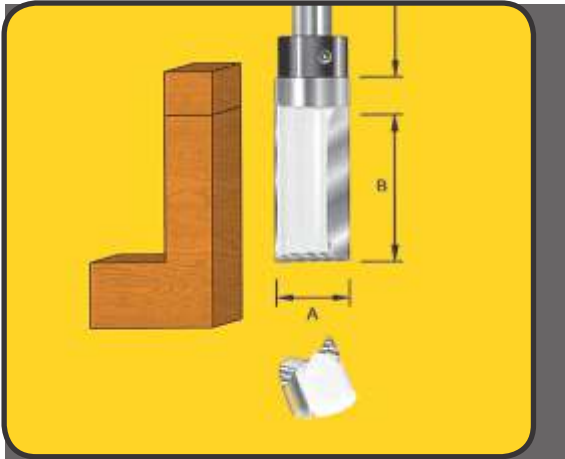

Inverted Flush Trim

Used to plunge and trim flush to top mounted template.

Product #	A mm	B mm	
TB8216	12.7	25.4	
TB8216S	12.7	9.5	Hinge Setting Bit
TB8220	16.0	25.4	
TB8236/2	28.6	38.0	1/2"shk
TBX8224/2	19.0	50.0	1/2"shk

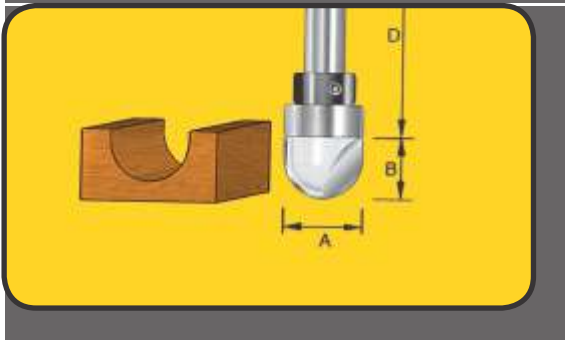

Inverted Down Shear Flush Trim

Specifically designed for heavy duty, fast, clean cutting which gives a superior finish with minimal chipping to top surface

Product #	A mm	B mm	
TBDS8224/2	19	38.1	1/2"shk

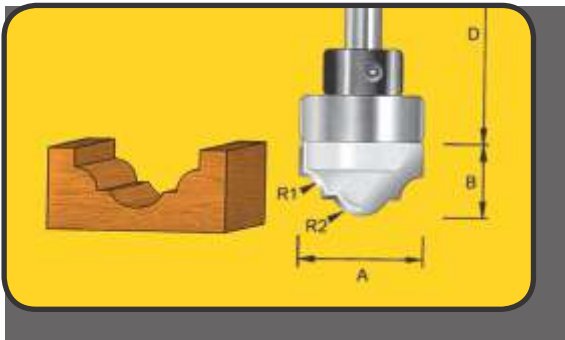

Core Box- Top Bearing

Surface reeding and lettering using top template

Product #	A mm	B mm	
TBCB16	12.7	12.7	

Classical Plunge-Top Guide

Surface Classical plunge bit used on doors & draw fronts and draws. Can also be used for edge cutting.

Product #	A mm	B mm	Rad 1&2
TBCG10	22.0	12.7	4 & 5.5
TBCG12/2	35.0	14.3	6.4 & 10

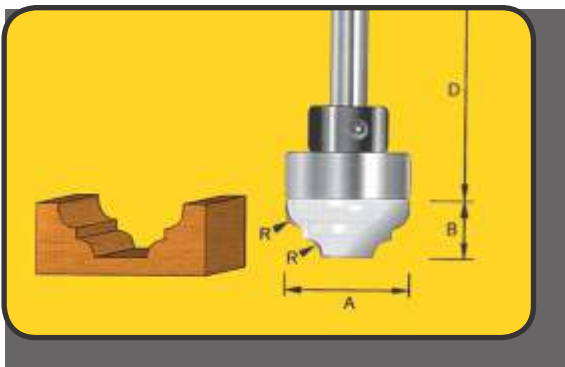

Provincial Plunge-Top Guide

Surface Provincial plunge bit used as above but the surface groove can be widened to give better proportional groove to the face of the job.

Product #	A mm	B mm	Radius
TBPG8	22.0	9.9	3.2
TBPG14/2	35.0	14.3	5.5

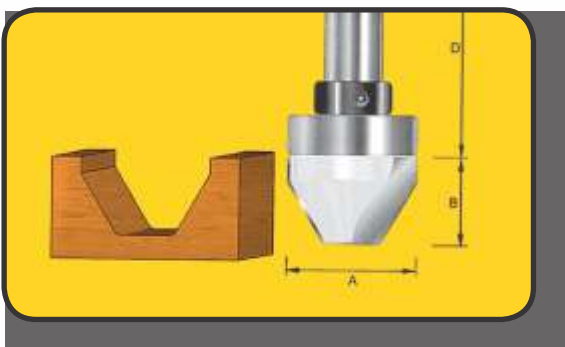

V Lettering-Top Bearing

This bit has a 10mm flat on the point for large top bearing guided signage.(1/2 Shank)

Product #	A mm	B mm	
TBVL28/2	28.0	19.0	

Straight Flush Trim Bits

These precision flush trim bits are specifically designed for heavy duty trimming. The smaller diameter bits are used for trimming into tight corners. All of these bits are fitted with high speed double shielded ball bearings for longer bearing life.

HP Bits have a ocer double life

Product #	A mm	B mm	
TB8008	6.4	25.4	
TB8012	9.5	25.4	
TB8012HP	9.5	30.0	High Performance
TB8016	12.7	25.4	
TB8016HP	12.7	30.0	High Performance
TB8016/2	12.7	25.4	1/2 shk
TBXX8016/2	12.7	50.8	1/2 shk

Fitted with two bearings

Product #	A mm	B mm	
TBB8012	9.5	25.4	
TBB8016/2	12.7	25.4	1/2 shk
TBBX8016/2	12.7	38.1	1/2 shk

Down Shear Flush Trim Bits

Specifically designed for heavy duty, fast, clean cutting which gives a superior finish with minimal chipping to top surface

Product #	A mm	B mm	
TBDS8024/2	19	38.1	1/2"shk
TBDSX8024/2	19	50	1/2"shk
TBDSX8424/2	19	50	bearing top & bottom

30° Bevel Trim Bit

For use in Router or Trimer, ball bearing guided.

Product #	A mm	B mm	Angle
TB8130	12.7	10.0	30°

22° Straight Bevel Trim Bit

The bit for the machine. ie. Laminate Trimer

Product #	A mm	B mm	Angle
T2622/-	12.7	12.7	22°

Triple Surface Beading

3.2mm radius beads having a pitch of 6.4mm

Product #	A mm	B mm	Radius
TBTB22/2	22.0	25.4	3.2R

Triple Surface Flute Bit

Same as above but surface fluting

Product #	A mm	B mm	Radius
TBTf22/2	22.0	25.4	3.2R

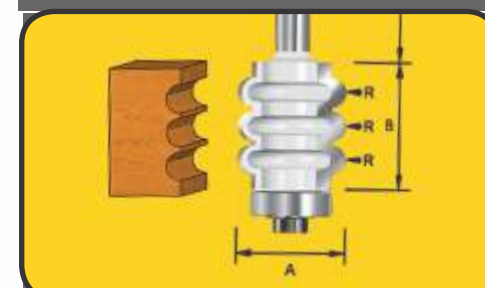
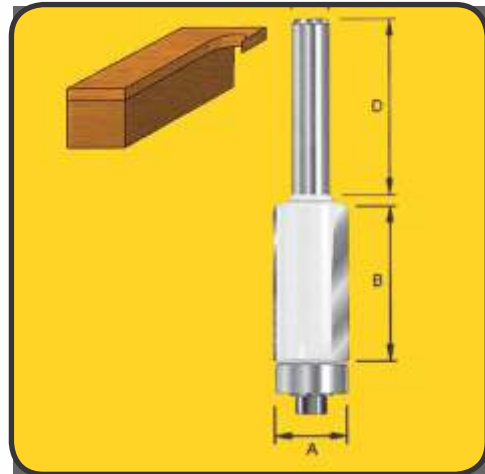

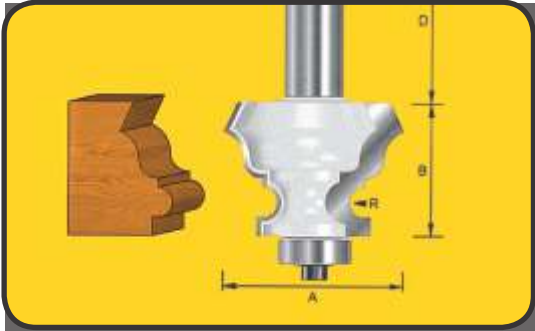

Indent Ogee/Sml Full Bead

Used for crowning furniture and table edging

Product #	A mm	B mm	Radius
TBOGB35/2	40.0	30.0	3.2

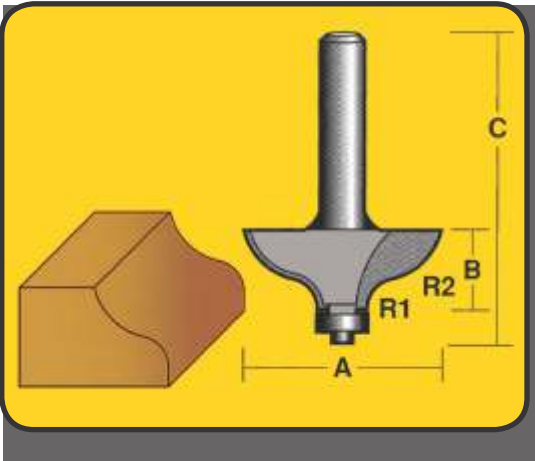
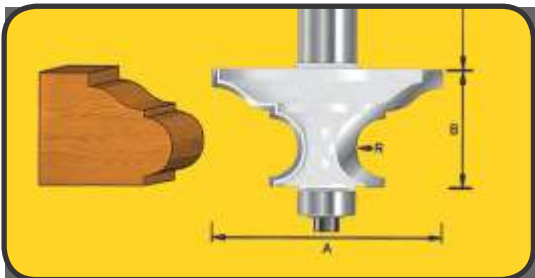

TABLE EDGE BIT

A Popular bit for finishing table edges, With ball bearing guide, 12.7mm (1/2") SHANK.

Product #	A mm	B mm	C mm	Rad 1&2
TBEB14/2	50.8	18.3	79.0	8.0 & 16.0



Low Roman Ogee/Lge Bead

Mainly table edge usage giving full beaded return with or with out a step on the bottom edge

Product #	A mm	B mm	Radius
TBEB16/2	51.0	25.4	6.4

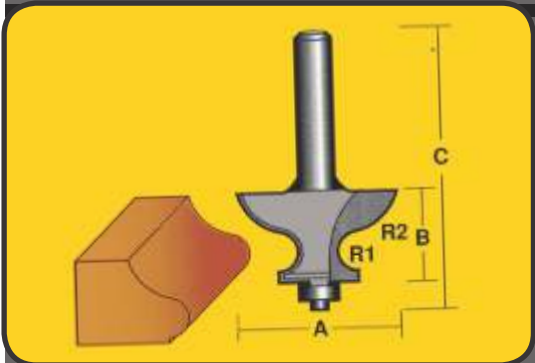

TABLE EDGE BIT WITH RETURN

This bit has a return to round over bottom of table for an attractive finish. With ball bearing guide, 12.7mm (1/2") SHANK.

Product #	A mm	B mm	C mm	Rad 1&2
TBEB15/2	50.8	29.2	89.0	8.0 & 16.0



60' Chamfer/Steep 'S' Mould

Flat edge mould for furniture or table edge

Product #	A mm	B mm	Radius
TBEB12/2	35.0	38.0	4.8

All 1/2 x 38mm shk Face moulding bits are used extensively for the moulding of skirting boards, picture frames, the crowning and skirting of large chunky furniture.

Short Classical Face Mould

Shallow cutting depth

Product #	A mm	B mm	Radius
TBFM12/2	24.0	35.0	4.0

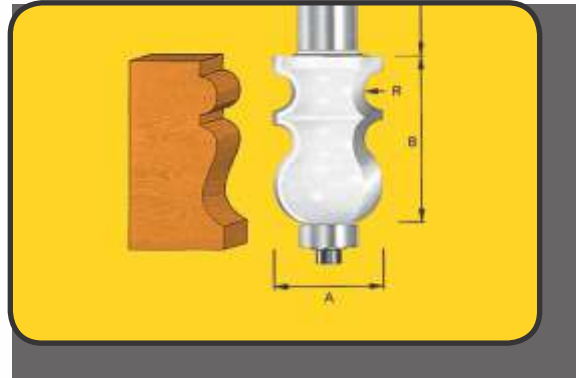

Bead/Shallow Surface Concave

Product #	A mm	B mm	Radius
TBFM18/2	25.4	35.0	4.0



Deep Federation Face Mould

Consumes greater depth of timber on top end

Product #	A mm	B mm	Radius
TBFM36/2	35.0	41.5	3.2

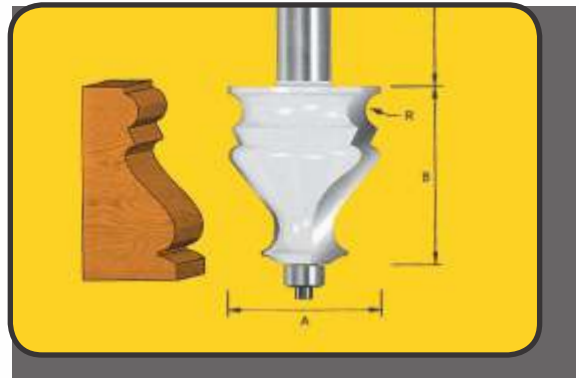

Bead/Low S / Plinth Face Mould

Product #	A mm	B mm	Radius
TBFM48/2	27.0	41.5	3.2

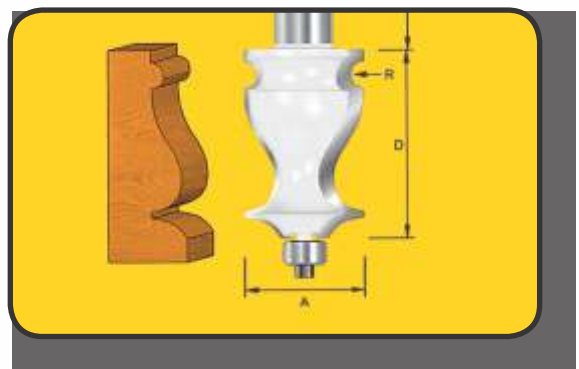

Flat Classical Face Mould

Low timber depth consumption

Product #	A mm	B mm	Radius
TBFM54/2	25.4	43.0	3.2



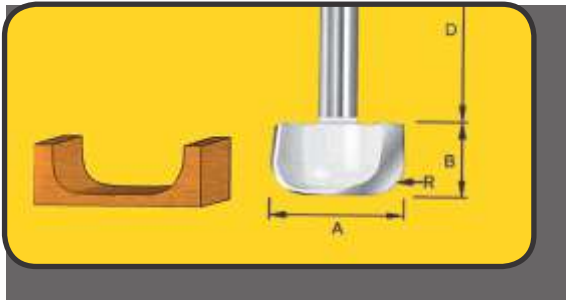

Dish Carving Bit -1/2" (12.7mm)

Shk A unique bit that routs out the bottom and sides to produce a dish like shape. Used extensively for making trays, bowls, and raised lettering.

Product #	A mm	B mm	Radius
TD716/2	32.0	12.7	6.4

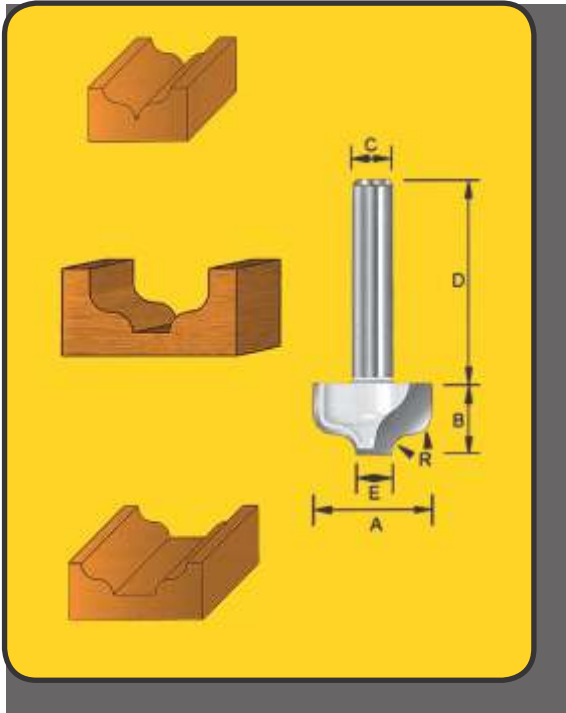

Ogee Fine Point. E=1 mm

Fine point used in router lathe work.

Product #	A mm	B mm	Radius
TF7506/-	21.0	15.0	4.8
TF7509/-	27.0	16.0	6.5

Ogee Bits- Standard. E=4.8mm

Standard Ogee bit is used for edge & face work

Product #	A mm	B mm	Radius
T7506/-	24.0	15.0	4.8
T7509/-	31.0	16.0	6.5

Ogee Wide Point. E=13 mm

Used to rout the face of panel doors etc.

Product #	A mm	B mm	Radius
TW7506/-	31.0	15.0	4.8
TW7509/-	38.0	19.0	6.5

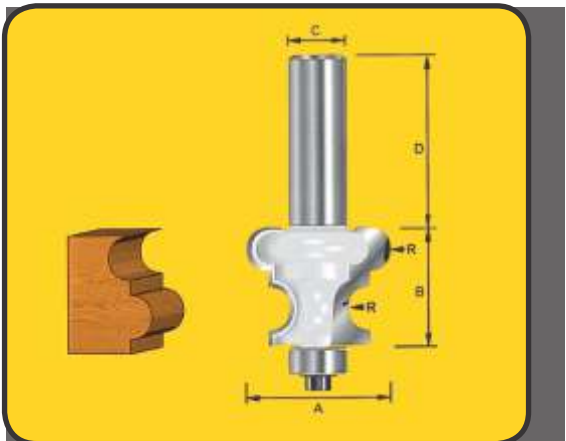

Bead & Flute Bit

Sectional edge moulding and used extensively for male & female sections of Roll top desks

Product #	A mm	B mm	Radius
TBBF8/2	25.4	16.0	3.2

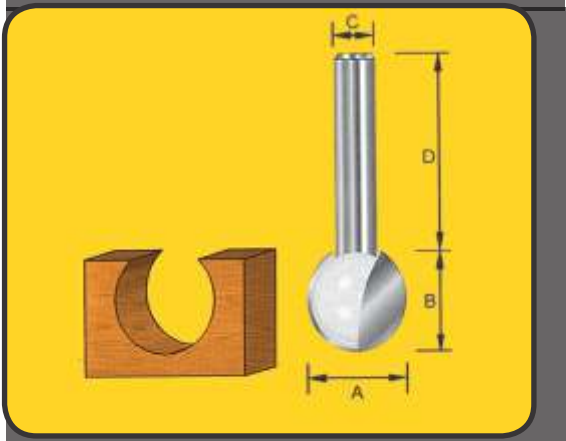

Ball / Rope Track Bits

Designed to plunge and cut a open top ball track after using a straight cutter to relieve the centre just larger than the shank size of the track bit being used.

Product #	A mm	B mm	C x Dmm
T832/2	25.4	25.4	12.7x38

Dovetail bits-(1/4") 6.35 x 30 shank

Dovetail drawer jointing is the most popular use of these bits but half housing and dovetail jointing used in shelving is also very popular.

Product #	A mm	B mm	E °
T1018/-	14.0	13.5	15°

for use on 7/8' (22mm) pitch comb dovetail kit with template ring guide

T1019/-	15.0	12.7	15°
---------	------	------	-----

for use on 25mm pitch comb dovetail kit (Hitachi, Makita, Ryobi etc) also with template ring guide.

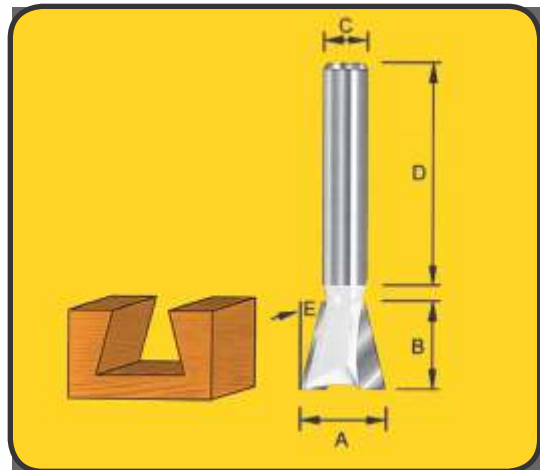

Dovetail Bit- with Top Bearing Guide

Product #	A mm	B mm	E °
TB19149/-	14.9	13.0	15°

This 12.7mm Ball bearing guided Tungsten Carbide tipped dovetail bit is used in conjunction with a (1/2') comb dovetail kit and without the use of the template ring to produce a professional dovetail joint quickly.

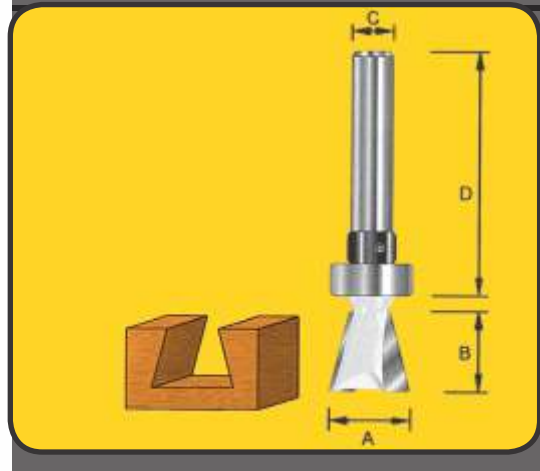

Dovetail Bit- Shallow

This 16mm, 7° Dovetail bit is fitted with a 16mm bearing (B101 16mm) This bit is suited for the KL-15 dovetail jig, but by changing the ball bearing to a 12.7mm (B105 12.7") bearing it will produce a shallow dovetail joint when used with the conventional 12.7mm (1/2") finger comb dovetail jig

Product #	A mm	B mm	E °
TB1907	16	16	7°

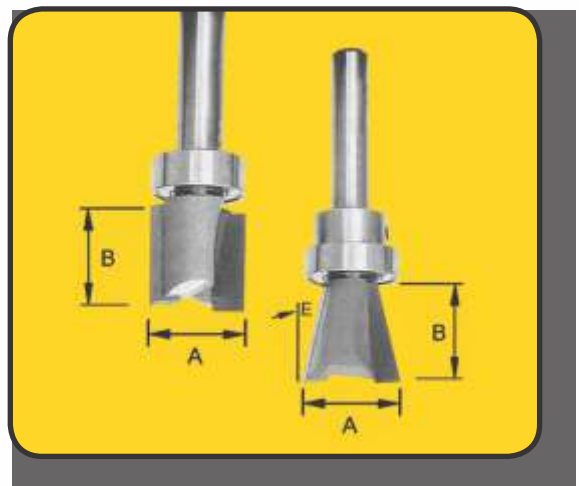

Inverted Flush Trim- Shallow

This bit fitted with 12.7mm top bearing, when used with the conventional 12.7mm comb dovetail jig will produce square finger joints

The TB8220 16mm inverted trim bit with a 16mm bearing can also be used to produce square finger box joints with the KL-15" through dovetail jig Both TB8216S and TB8220 (see page 10) bits can also be used as top template flush trim bits

Product #	A mm	B mm
TB8216S	12.7	9.5

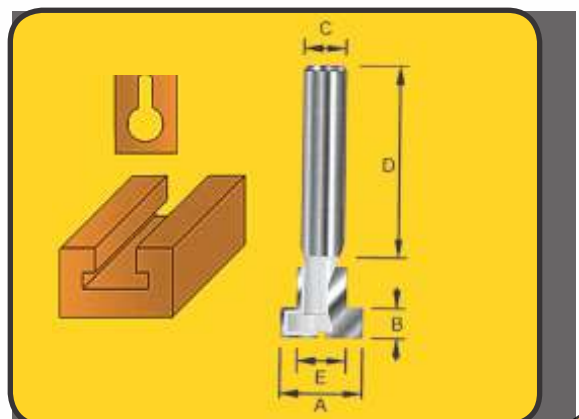

Hook Slot Bits (1/4') 6.35 x 32mm shk

These bits drill and slot a handy screw, nail or hook slot in the back of a shield, picture frame etc, to allow easy and secure hanging.

Product #	A mm	B mm	E mm
THS12/-	9.5	3.2	6.4
THS16/-	12.7	4.8	6.4

RAISED PANEL BITS

Selection of Raised Panel bits available in a variety of shapes.
 Depth of cut can be made greater or smaller depending upon the timber thickness.

Shallow Double Cove Bits
 TBPD3/2 or TPD3/2 with no bearing

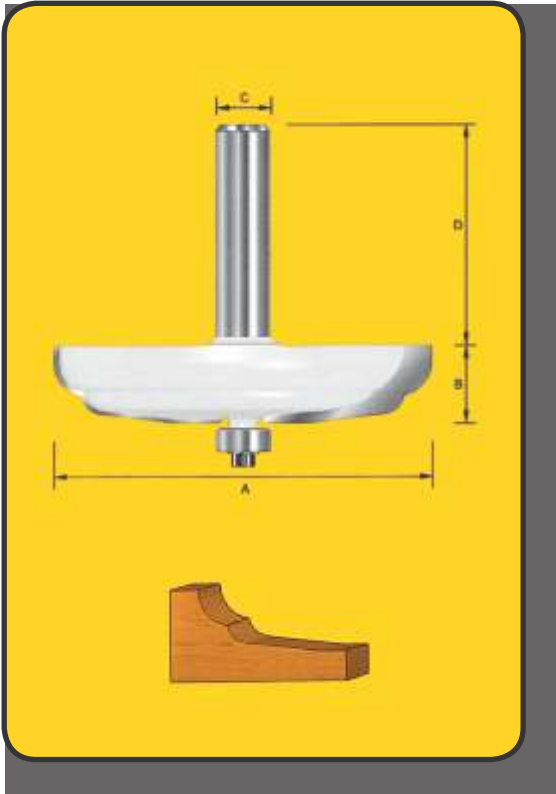

Product #	A mm	B mm	Angle/Rad
TBOG75/2	70.0	16.0	16.0
TBPD3/2	72.0	16.0	
TPD3/2	72.0	16.0	No bearing
TBPD4/2	60.0	16.0	
TPD4/2	60.0	16.0	No bearing
TBRP40/2	41.0	13.0	25'

Low Profile Ogee Bits
 TBOG75/2



Flat Double Ogee Bit
 TBPD4/2 or TPD4/2 with no bearing

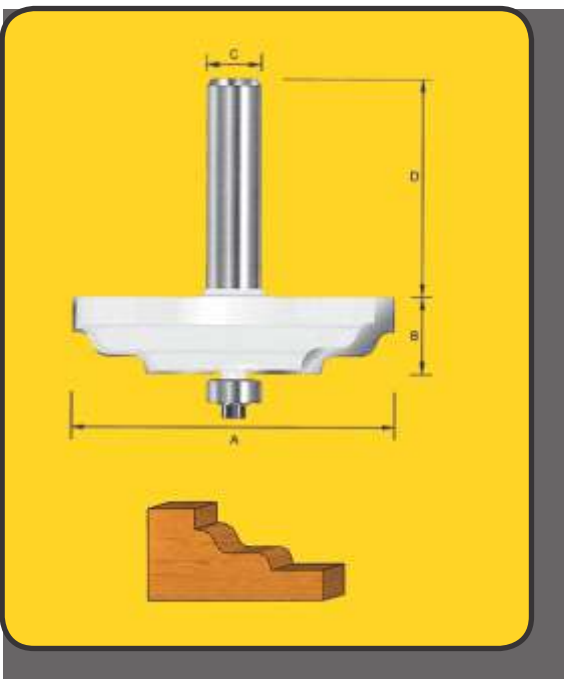

TBRP40/2 25' x 13mm
 Raised Panel Bit

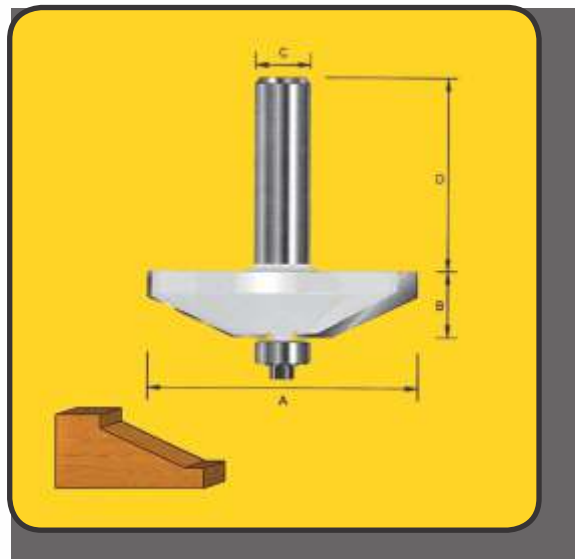

PANEL DOOR STACK SYSTEM

The ONE Stack System
 Bit cuts both mating parts of the joint with out the bit being disassembled

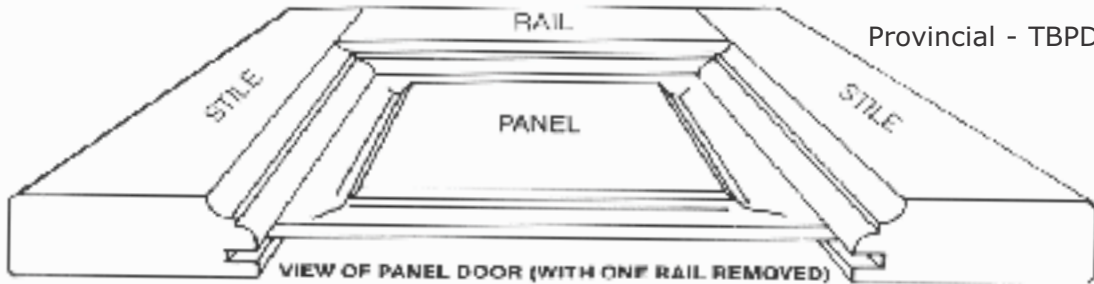

Provincial - TBPDS14/2

STEP 1 & STEP 2 USE THE SAME BIT

STEP # 1
 CUT THE RAIL
 & STILE ON
 EDGE

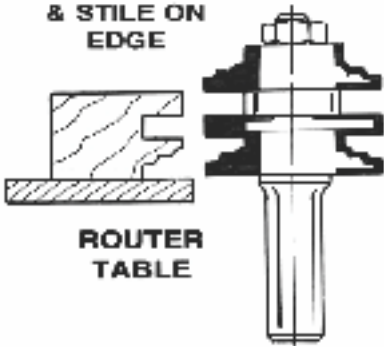

ROUTER
 TABLE

STEP # 2
 CUT THE
 RAIL END
 GRAIN

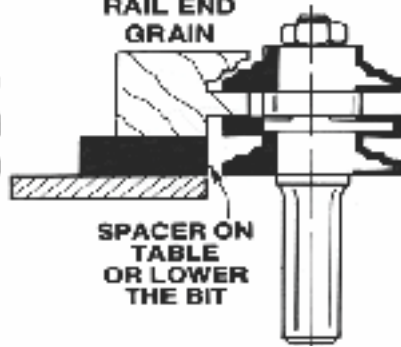

SPACER ON
 TABLE
 OR LOWER
 THE BIT

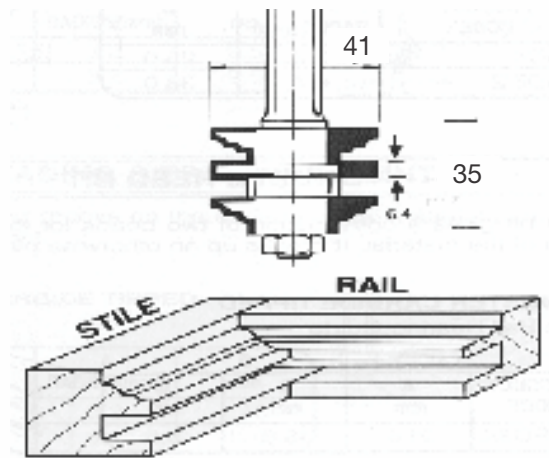

The STACK SYSTEM is designed to machine both the long sections of the stile and rail and rail end to make the joint complete **using only ONE bit**. When used in conjunction with a router table this bit can be either lowered to cut the rail end or with the use of a block spacer on the router table no adjustment would be necessary. You do not have to disassemble and reverse the unit, as you do with 2pc systems. Available in 1/2 shank only.

Capacity timber thickness 16- 23mm

Ogee - TBPDS10/2

Classical - TBPDS11/2

Traditional - TBPDS12/2

Also available in Chamfer - TBPDS13/2 and Provincial - TBPDS14/2

A = 9.5mm B = 23.8mm C = 12.7mm D = 41mm

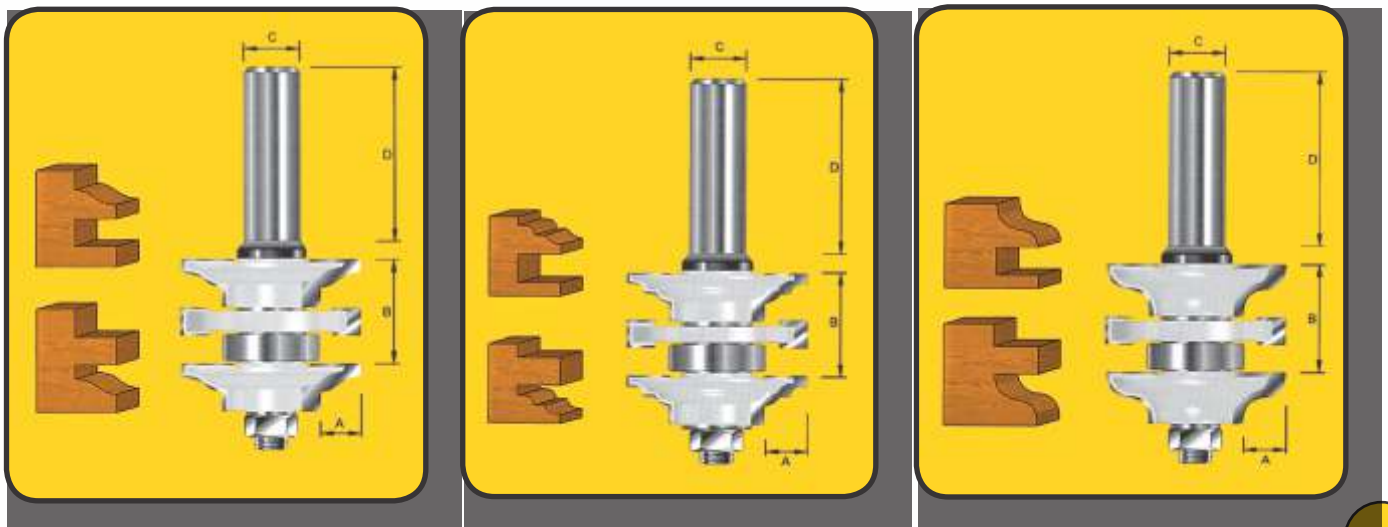

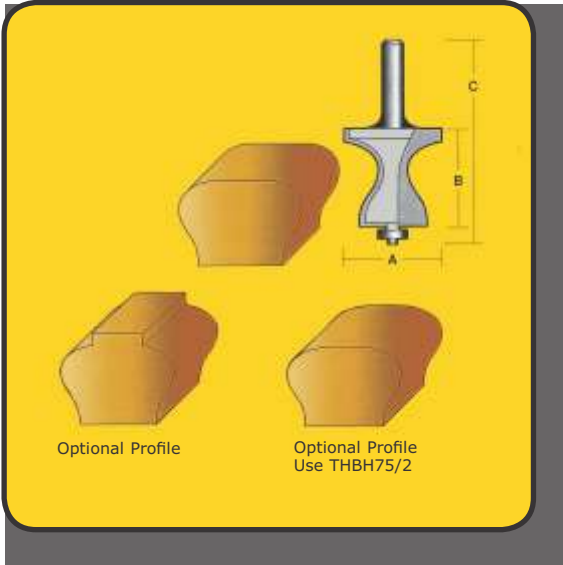

STAIR HANDRAIL BIT

This bit will produce an attractive and functional hand rail for balustrades. It can be used in conjunction with the half bull nose bit to curve the top over job. This will produce an optional profile. 12.7mm (1/2') SHANK

Product #	A mm	B mm	C mm
TBHR50/2	50.8	57.1	116.0

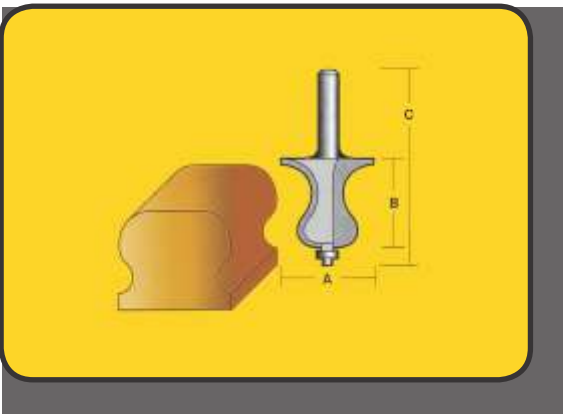

STAIR HANDRAIL BIT

Profile on top of rail can be varied using a half bull nose bit up or down. With ball Bearing Guide, 12.7mm (1/2') SHANK

Product #	A mm	B mm	C mm
TBHR40/2	58.7	38.7	96.8
TBHR60/2	54	50.8	110.0

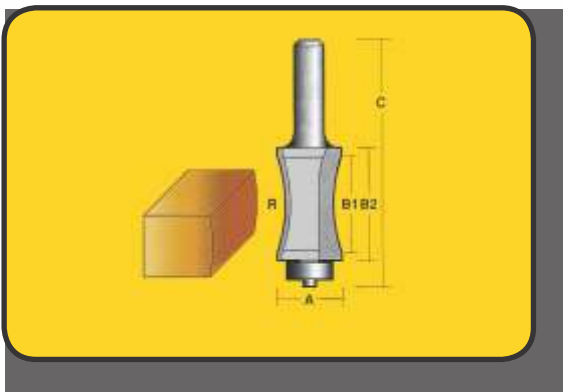

HALF BULL NOSE RADIUS BITS

A handy bit for finishing wider timbers. The adjustment of machine height gives a variety of different forms.

Product #	A mm	B1 mm	B2 mm	C mm	R mm
TBHBN45/2	25.4	30.0	36.0	92.0	45.0
TBHBN60/2	27.0	41.0	47.6	102.0	60.0
TBHBN75/2	28.6	50.8	57.1	111.5	75.0

Servicing Tungsten Carbide Router Bits and Circular Saws

Full re sharpening should only be done with professional equipment, as diamond wheels must be used. Correct cutting angles and reliefs must be maintained this should be carried out by experienced sharpening services.

Safety Precautions

Always switch off power and unplug the power tool when changing cutting tool. The use of eye goggles and ear muffs is strongly recommended.

TONGUE & GROOVE SET

When using this set you produce the tongue with the two cutters and to produce the groove you just take off one of the cutters and place another bearing on either side of the single cutter for full square and balanced guidance to complete the tongue & groove joint.

Product #	A mm	B mm	Capacity
TBTG19	9.5	6.4	19.0 1/4"shk
TBTG19/2	9.5	6.4	19.0 1/2"shk

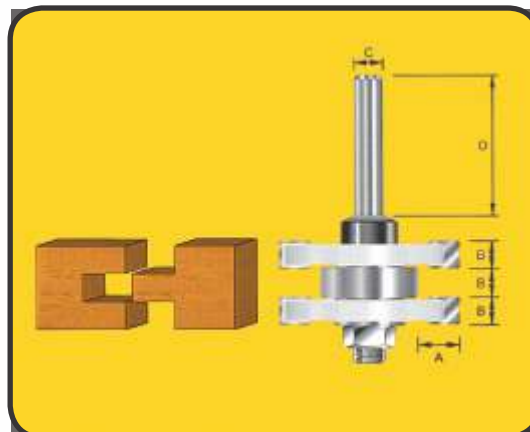

WINDOW SASH CUTTER SET

Create you own window sashes and cross bars with this unique set. 12.7mm x 38 mm shank with 22mm ball bearing

Product #	A mm	B mm
TBWS35/2	35.0	44.4

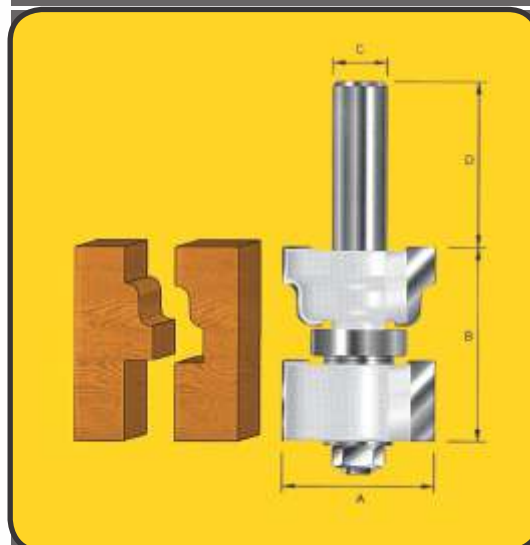

DRAW PULL BIT

This bit produces finger pull handle draws and doors.

Product #	A mm	B mm	R & r
TDP35/2	38.1	22.0	12.0
			1.6

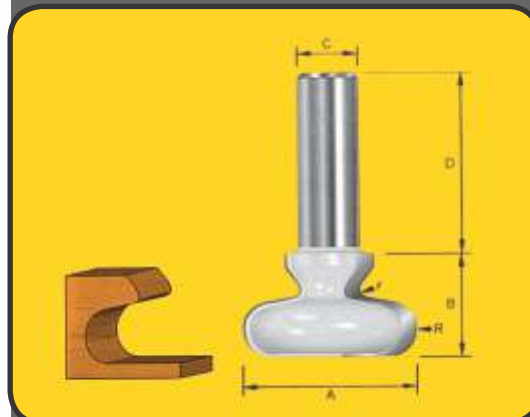

MITRE LOCK BIT

This Mitre Lock bit will make a locking joint at 90° or in a straight line. It is recommended that a jig be constructed to hold the section which is to be cut in the vertical position.

Product #	A mm	Capacity
TML38	38.1	8-14thick 1/4"shk
TML60/2	50.0	9-20thick 1/2"shk

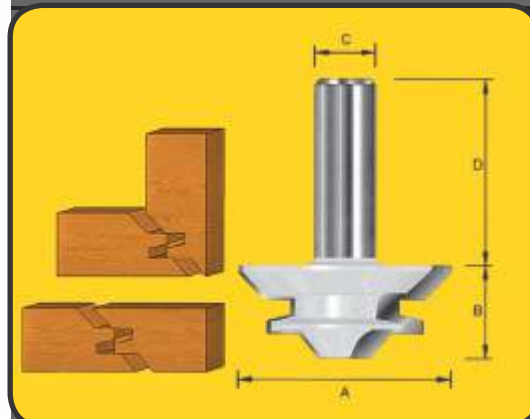

All slotting cutters have 22mm Dia bearing 8 ID

Product #	A mm	B mm	Shk mm
TM5004	47.4	4.0	6.4x32
TM5004/2	47.4	4.0	12.7x38

Above two cutters are used extensively for biscuit cutting

General slotting Cutters

TM5002.5/2	47.4	2.5	12.7x38
TM5003.2/2	47.4	3.2	12.7x38
TM5006.4/2	47.4	6.4	12.7x38
4 Cutting Tips			
TM7002/2	47.4	2.0	12.7x38

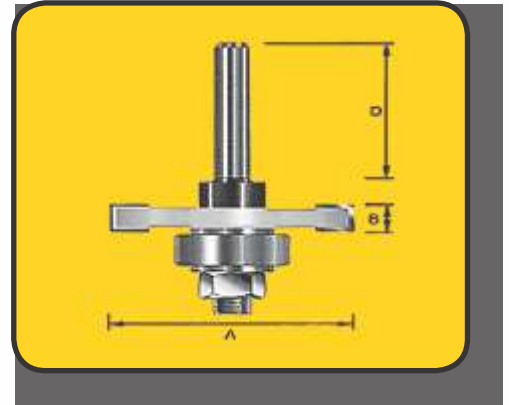

Straight Finger Joint Set
 Adjustable Depth

This set produces strong 4mm straight finger joint, depth of fingers can be adjusted by using various bearings etc

Depth of joint using

Router m/c guide (no Bearing)	16mm
22mm Bearing	12.8mm
28mm Bearing	9.5mm
35mm Bearing (optional BA115)	6.4mm

Product #	A mm	B mm
TAFJS40/2	47.6	35

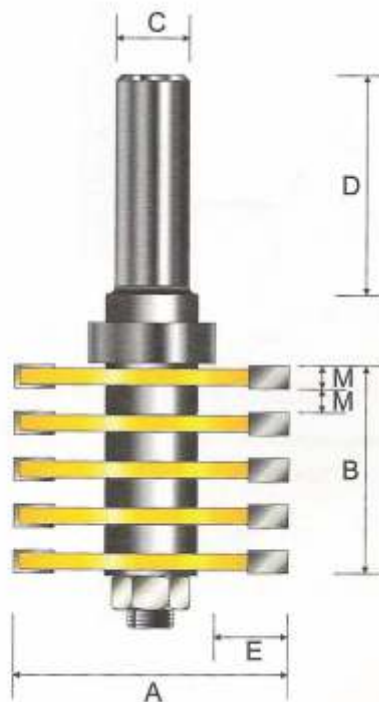

FINGER JOINT SET
 TAFJ40/2

Cutting capacity 10min to 40mm max. 12.7x38mm shk
 28mm x 8mm ID bearing.
 Finger 40mm dia
 Kerf 1.8 -3.3mm

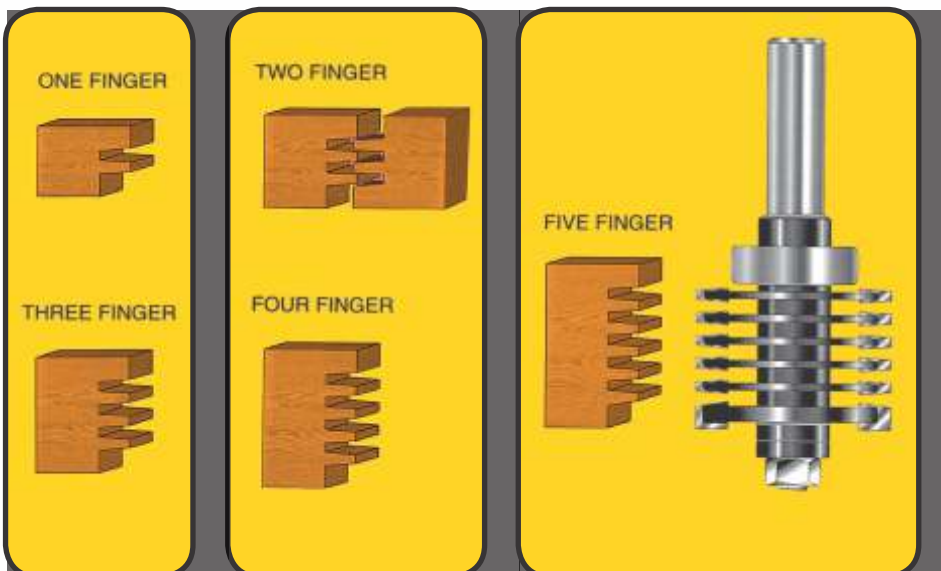

Produces a beautiful, strong exposed finger joint on end and long grain
 Make central identical cuts on both pieces always using the butting edge cutter, **invert one piece & fit together** (See Insert Two Finger Picture)

Approx size of joint

- one finger 10-16mm
- two fingers 16-21mm
- three fingers 21-26mm
- four fingers 26-31mm
- five fingers 31-37mm

ARBORS for use with Slotting cutters

Product #	A mm	B+D mm	Bearing
ARBOR/1	8.0	55.0	22mm
ARBOR/2	8.0	62.0	22mm

Ball Bearings

Product #	A mm	B mm
B101	16.0	6.4
B102	19.0	6.4
B103	19.0	12.7
B104	16.0	4.8
B105	12.7	4.8
B106	9.5	4.8
B108	12.7	6.4
B109	28.5	12.7
BA112	22.0	8.0
BA114	28	8
BA115	35	8
B107	6.4	3.2
B117	35.0	12.7
B118	38.0	12.7
B119	19.00	4.8

Bearing Stop Collars

INCLUDING ALLEN KEY

Product #	B mm
COLLAR/1	6.4
COLLAR/2	12.7

Collet RC1 12.7 od 6.4 id

Key/screw/washer set KS01

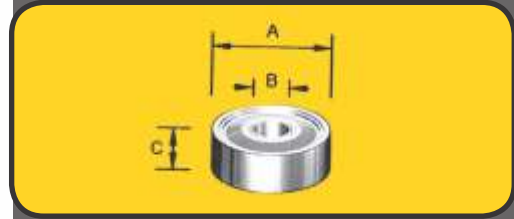
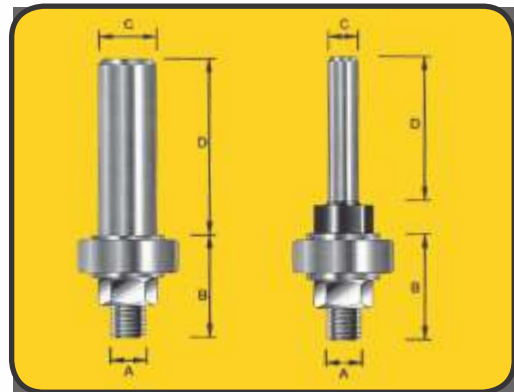

Basic Production step of a TruaCut Router Bit Under the Highest levels of ISO 9002 Standards

1/ Lengths of high grade steel



2/ CNC Lathe turning starts the first stage of actual production. This is where we see the actual form of the bit take place in gyroscopic precision.



3/ CNC Milling cuts out the tip seats for the Tungsten Carbide tips. This operation also forms the rounded gullet which is a vital area in the spacing for our Anti-kickback design. Too big an area voids the anti-kickback, too small will not allow for quick and easy removal of timber .

4/5 Special grade micro grain Tungsten Carbide tips are brazed to the body. Three pieces are now one integral item.



6/ Initial Grinding of tips close to form.

7/ The coating is applied and baked on at this stage. The bit now has a non-stick, non-drag surface all over prior to finish grinding.



8/ The shank is ground first so as to maintain concentricity

9/ Sharpening of the Tungsten Carbide tips takes place under a steam of grinding fluid keeping the tool cool and Diamond wheel free of impurities. This along with CNC controlled machinery and expert tool makers produces a mirror like finish on the TruaCut Router Bits.



10/ Quality control is conducted through out all stages of production and when assembled and packed into our practical and attractive Clear plastic tool boxes you have another quality tool from.

**MULTI-SAW
 TUNGSTEN CARBIDE TIPPED**

Dia Suits most popular angle grinders and small saws designed to cut:
thin steel, aluminium, copper, plastic & fibre glass.

- No Sparks
- No Dust
- No Burring

Product #	mm	Teeth	Bore
CMS1102020	110mm	20	20/16
CMS1102022	110mm	20	22.2/16

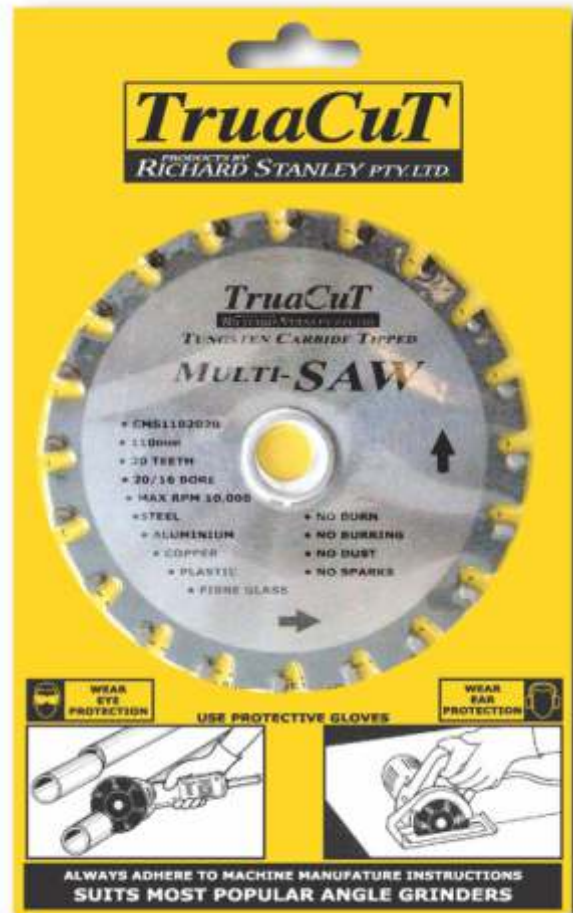

**TUNGSTEN CARBIDE
 PLANER BLADES**

Double edge for all 82mm portable power planers that are fitted with blade adapters

Product #	Description	mm
DTB822	- 1 Pair, 2 Blades Per Card	82 mm



Product #	Description	mm
DTB8210	- 5 Pair, 10 Blades Per Card	82 mm

Diamond Router Bits

For use in Router Machines



Diamond Router Heads

For use on Angle Grinders (M14 Thread)



Stanley TruaCut Vacuum Brazed Diamond Router Bits are used for routing shapes into masonry products. Granite, marble, natural & synthetic stone, ceramics, carbon fibre, concrete and compressed fibre cement products. **Used DRY.**

Stanley TruaCut Vacuum Brazed Diamond Heads are used on Angle Grinders with (M14 thread as used in Australia) to grind flats or produce a perfect profile on a wide variety of materials **WET or DRY** and at any speed as the diamonds are brazed on using our EXTRA strong bonding vacuum brazed technology. This bonding process allows 40% more exposure of the diamonds to do cutting than electroplated method. They also hold their shape during its life. The small bearing runs on the front face and the larger hard rubber rimmed bearing holds the top surface for safe and easy control of the profile head during grinding. Both ensures the profile shape is consistent as you move the grinder back & forth until the full depth & shape is completed ready for the polishing process. There are water holes in the heads if your grinder has water adaption as original manufacturer supply. Life increases by 50% plus when water is used. But they can be used DRY.





**Rounding Over Bits...
60/70 Diamond Grit**

Product#	Radius	Product#	Radius
DRB504	3.2mm	DRB512	9.5mm
DRB505	4mm	DRB516	12.7mm
DRB506	5mm	DRB520	15.8mm
DRB508	6.4mm	DRB524	19mm



**Vee Grooving Bit
C=40/50Grit**

DRB128C 11mm Depth of cut
 DRB129C 17mm Depth of cut
 DRB129 60/70Grit 17mm Cut



**Core Box Bit
40/50 Grit**

DRB432C 25.4mm Wide cut



**Chamfering Bit
60/70 Grit**

DRB916 12mm Depth of cut



**Ogee Bit
60/70 Grit**

DRB7512 10mm Rad 20mm depth



**Flush Trim Bit
60/70 Grit**

DRB8016 12.7 Dia x 38mm



**Inverted Trim
60/70 Grit**

DRB8236 28 x 38mm Cut



**Straight Bits
40/50 Grit**

DRM1406C	6.4mm x 25mm
DRM1408C	8.0mm x 40mm
DRM1410C	10mm x 40mm
DRM1413C	13mm x 40mm

**Rounding Over Heads
 Top & Bottom Bearing Guides
 40/50 Grit**

Prod #	Radius & Depth
DVB508G	6.4mm
DVB512G	9.5mm
DVB516G	12.7mm
DVB520G	15.8mm
DVB524G	19mm
DVB532G	25mm
DVB540G	30mm



Bull Nose Heads 40/50 Grit

Prod #	Radius & Depth
DVBBN20G	9.5mm Rad for 20mm Sheets
DVBBN30G	15mm Rad for 30mm Sheets



Chamfering Heads 40/50 Grit

Prod #	Radius & Depth
DVB8170G	20 deg. X 25mm Flat Chamfer



Grinding Drum Head 40/50 Grit

Prod #	Radius & Depth
DVB8282G	65mm dia x 32mm depth

Hard Rubber Top Bearing on the Router Heads is either 85mm or 105mm Dia. The hard rubber bearing helps prevent the top finished surface from scratching but taping helps.



Ogee Head- 40/50 Grit

Prod # DVB7512G **Radius & Depth** 10mm Radius 20 depth of cut



Finger Grinder Head 60/70 Diamond Grit

Prod # DVB0032G **Radius & Depth** 25mm Dia X 30mm depth of cut



safety First- When using these Diamond grinding tools-1/ Always use Goggles, face mask, gloves and protective clothing. 2/Always take note of Router machine and Grinder manufactures instruction as to usage. 3/Only use water with equipment designed to deliver water to the tool/job safely. **REMEMBER ECLECTRICITY CAN KILL.**

Vacuum Brazed Diamond tools can run at high speed and dry but try to use a Router with variable speed(10,000 RPM)

For best – Move the Router/Grinder back and forwards in a sawing action until the full depth & shape is achieved. For polished Granit and Marble surfaces further polishing is required. Use various grit polishing pads.

Some Q & A. What is Vacuum Brazing? A: Vacuum brazing is a material jointing technique that offers significant advantages: extremely clean, superior, flux-free braze joints of high integrity & strength. The process can be expensive because it must be performed inside a vacuum chamber. Temperature uniformity is maintained on the work piece when heating in a vacuum, greatly reducing residual stresses due to slow heating & cooling cycles. This, in turn, can significantly improve the thermal & mechanical properties of the material, thus providing unique heat treatment capabilities. One such is heat-treating or age-hardening the work piece while performing a metal-jointing process, all in a single furnace thermal cycle. (Wikipedia)

Q. Advantages of Vac Brazed Diamond tools. A: The most important is that these tools can be used DRY & at varying speeds because there are 40% more exposed diamond to do the cutting / grinding. The Vacuum brazed Diamond tools are more aggressive than other forms of diamond tools. (electroplated type)

TruaCuT Products by Richard Stanley Pty. Ltd.
Cutting tool specialists for over 60 years in Australia



FIBRE CEMENT CUTTING BLADES

Product #	Dia	Bore	Teeth
PCD125224	125mm	22.2mm/16	4
PCD160204	160mm	20mm	4
PCD185204	185mm	20mm	4
PCD210306	210mm	30mm	6
PCD235255	235mm	25/20	5
PCD250306	250mm	30mm/25.4	6
PCD305308	305mm	30mm/25.4	8
PCD350308	350mm	30mm/25.4	8

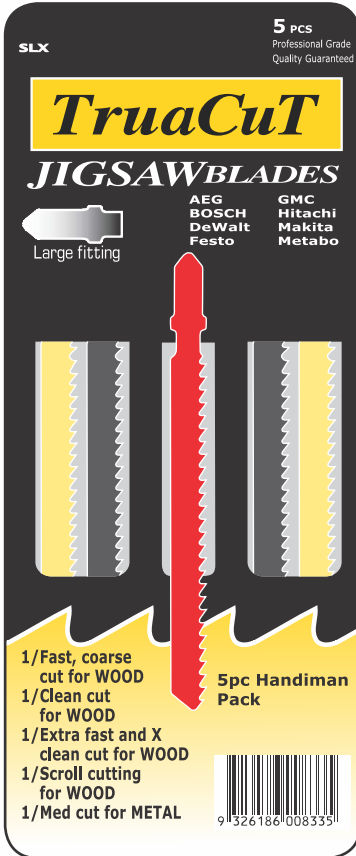

All available in 3 different end fittings:
 TruaCut Jig Saw Blades are of professional quality which are available in 5pc and 2 pc Hand Packs.



• Large Fitting: To suit - AEG, Bosch, DeWalt, Festo, GMC, Hitachi, Makita, Metabo, **Rak**



• Universal fitting: To suit - Black & Decker, Hitachi (older), Ryobi, Skil.



• Makita fitting: To suit - Makita (older)

Large	Universal	Makita(Old)	Description	TPI
-------	-----------	-------------	-------------	-----

2 Blade Hang Pack

S144D/2	SU44D/2	SM4/2	Extra fast cut for wood. Curve cutting	6
S111C/2	SU11C/2	SM3/2	Fast coarse cut for wood.	9
S101D/2	SU1D/2	SM5/2	Fast clean cut for wood.	6
S110S/2	SU10S/2	SM10S/2	X/Fast & X/Clean for wood.	8
S101BF/2	SU1BF/2	SM2BF/2	BiMetal. Fast xx/clean.Wood/ply/plastic	10
S119BO/2	SU19BO/2	SM9/2	Medium scroll wood cut.	12
S118A/2	SU18A/2	SM1/2	Fine Metal Cut.	24
S118B/2	SU18B/2	SM8/2	Medium metal cut.	12
S127D/2	SU27D/2	SM7/2	Non Ferrous metal/plastic cut	8
SLX	SUX	SMX	5 Assorted blades. Handyman Mix	

5 Blade Hang Pack

S101BR/5	Fast,Clean cut in Wood/Plastic	REVERSE DOWN CUT	12tpi	
S111C/5	SU11C/5	SM3/5	Fast coarse cut for wood.	9
S101D/5	SU1D/5	SM5/5	Fast clean cut for wood.	6
S110S/5	SU10S/5	SM10S/5	X/Fast & X/Clean for wood.	8
S101BF/5	SU1BF/5	SM2BF/5	BiMetal. Fast xx/clean.Wood/ply/plastic	10
S118A/5	SU18A/5	SM1/5	Fine Metal Cut.	24
SLX	SUX	SMX	5 Assorted blades. Handyman Mix	

5 Blade Hang Pack

S118B/5	Medium metal cut	12
S144D/5	Extra fast cut for wood. Curve cutting	6
S127D/5	Non Ferrous metal/plastic cut	8
S344D/5	Long Extra fast cut for wood. Curve cutting	6
S130DG/2	Diamond for masonry & fibreglass	30G

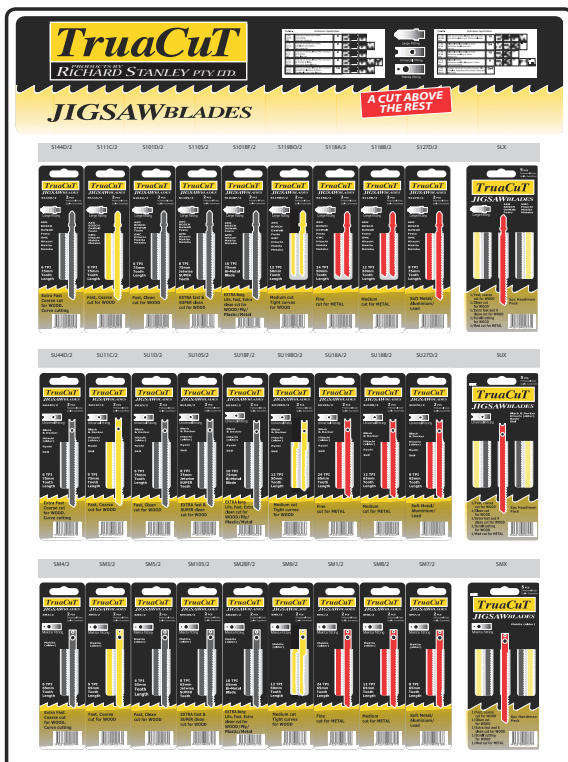

Jig Saw Blade Merchandiser

- Information header
- Clear product description and application on each pack
- Multi coloured packs
- 10 different blades
- 3 different end fittings
- 2 and 5 blade packs merchandiser available
- professional quality

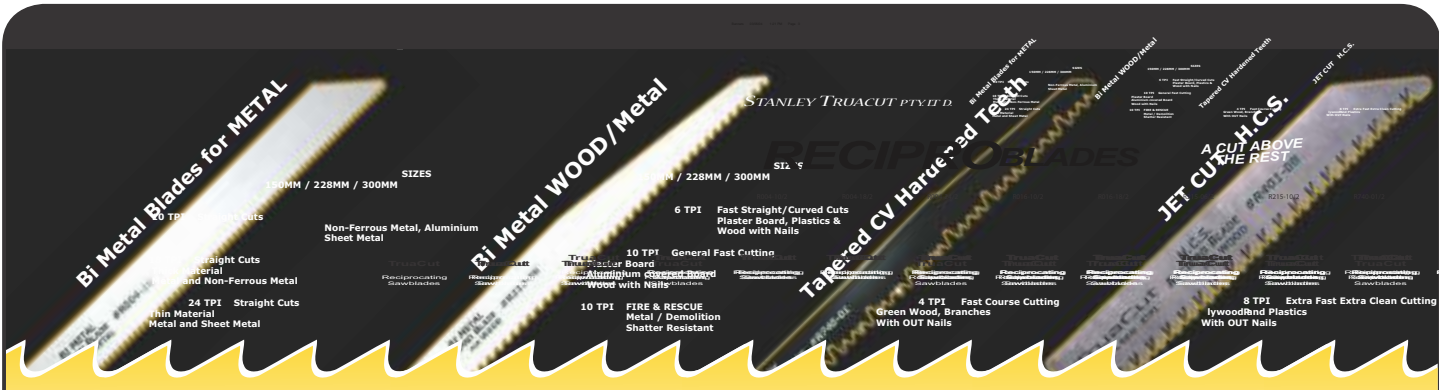

BI-METAL Reciprocating Saw Blades

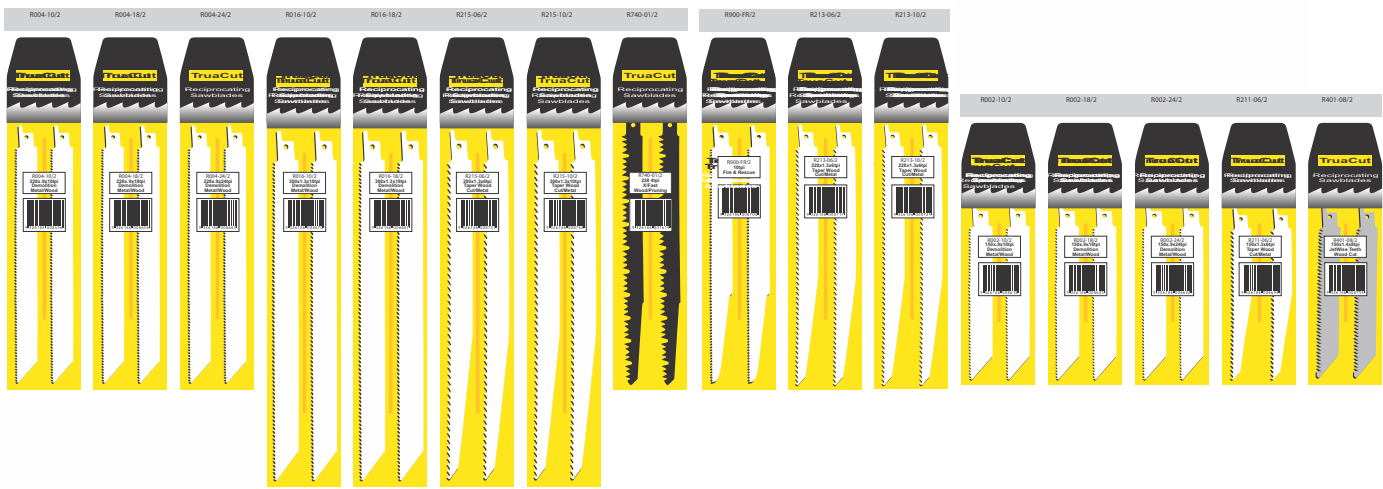

Recipro Blades 2 Packs

R004-10/2	150x .9x10tpi	Metal/wood	BiMet
R004-18/2	150x .9x18tpi	Metal	BiMet
R004-24/2	150x .9x24tpi	Metal	BiMet
R004-10/2	228x .9x10tpi	Metal/wood	BiMet
R004-18/2	228x .9x18tpi	Metal	BiMet
R004-24/2	228x .9x24tpi	Metal	BiMet
R016-10/2	300x 1.3x10tpi	Metal/wood	BiMet
R016-18/2	300x 1.3x18tpi	Metal	BiMet
R203-10/2	228x .9x10tpi	Taper Wood cut/metal	BiMet
R211-06/2	150x 1.3x6tpi	Taper Wood cut	BiMet
R213-06/2	228x 1.3x6tpi	Taper Wood cut	BiMet
R213-10/2	228x 1.3x10tpi	Taper Wood cut/metal	BiMet
R215-06/2	300x 1.3x6tpi	Taper Wood cut	BiMet
R215-10/2	300x 1.3x10tpi	Taper Wood cut/metal	BiMet
R401-08/2	150x 1.4x8tpi	JetWise Teeth Wood Cut Super fast super clean	HCS
R740-01/2	235	XFast Cut/Wood/Pruning	
R900-FR/2	228 1.6x10tpi	Fire & Rescue Demolition - Metal/Wood	BiMet
R811-GE/2	150mm	TUNGSTEN CARBIDE GRIT EDGE for Masonary products, Fibre glass & Cast iron pipes	
R813-GE/2	228mm	TUNGSTEN CARBIDE GRIT EDGE for Masonary products, Fibre glass & Cast iron pipes	
• R815-GT/2	300mm	TUNGSTEN CARBIDE GRIT EDGE TEETH for Masonary products, Fibre glass, Cast iron, Compressed board & Hebal blocks	
• Unique To TruaCut			

WHY BUY *TruaCuT* ROUTER BITS?

Years Experience

The Stanley family, through various entities, have been supplying quality cutting tools for the machine of a wide range of material for more than 60 years in Australia and throughout the world.

Geometric Designed for Industry

Based on decades of field testing and continual improvement has earned for Stanley TruaCut products, a reputation for reliability and quality second to none.

Anti-Kickback

All TruaCuT shaped router bits incorporate this very important feature. The reason for this is that with the old style bits, have a tendency to kickback at you when the job comes into initial contact with the router bit. This kickback could cause serious injury to you.

Shear, Hook & Clearance Angles

These angles can differ from bit to bit depending upon the complexity of the shape. The Shear angle is measured from the axis of the bit. This is generally a positive, continuous slant angled cutting edge which shear cuts smoothly rather than have a one chop cut by the full form, straight cutting edge with each revolutionary pass. The Hook angle is measured from a line passing through the centre to the outside diameter of the bit. This hook angle on the face of the bit hooks under the shaving, helping to sever the waste smoothly. The Clearance is the angle at the back of the full form on the outside diameter of the bit. Too greater clearance causes the bit to blunten quickly but too little clearance will cause the rear of the tip to drag on the surface of the job thus burning the surface. These angles must be all correct in conjunction with each other so as to give a Router bit that will cut clean and smooth producing a professional finish like a TruaCuT Router Bit does for you.

Material & Production

TruaCuT Router bits are machined from High Quality Steel. During the turning, milling and brazing process many quality control checks are performed. We believe that the finished Router bit is no better than the foundation process. As material is removed from the steel in the turning and milling process there is a need to stress relieve the tool. Also during the brazing of the Tungsten Carbide tips there is stress build up due to the fact that expansion and contraction rates of steel as to tungsten carbide is quite different. Thus the need for tightly controlled rate of temperature reduction.

Tungsten Carbide Tips.

TruaCuT use a Premium Grade micro grain tungsten carbide. Amongst other qualities this allows for a mirror like finish and sharp tougher cutting edge to be produced giving a longer cutting life when machining very hard materials.

Unique Black Coating

Powder coating is the next most important step in the production process. Because of the revolutionary full body Anti-Kickback design used we apply this non-stick/ non-drag black coat which prevents residue build up behind the cutting edge on the body and inturn prevents drag on the surface of the job which can severely mark the finished cut surface.

Grinding & Sharpening There are THREE basic processes.

The first process is the grinding of the shank to very tight tolerance and micron finish. All the other processes in the grinding of the router bit are then ground concentrically to the shank. The reason being that the shank is held and rotated to grind the form.

The second is the grinding/sharpening of the Tungsten Carbide tips using diamond wheels under a continuous flood of coolant. With the combination of the Premium Grade tungsten carbide and the CNC wet grinders we can produce a mirror like finish on each TruaCuT bit giving you tougher, cleaner and smoother cutting router.

Quality Control

Quality Checking is carried out at every stage of manufacture. Computer Numeric Controlled machinery is used in the world class factory which is updated as new technologically superior machinery comes on to the world manufacturing stage.

Product Presentation

Each TruaCuT router bit has its final inspection prior to its packing in our two part handy plastic storage box. The bit is inverted and securely slid into the black base and then the clear plastic top is locked onto the base allowing you to see the full profile of the product required. Each plastic box has **TruaCuT** seal of specification approval adhered to the front bottom section of it showing product name, number and specification etc. The after sale care of the router bit is just as important to us as it is to you. That is why we pack in these safe and attractive storage boxes which are ideal for the workplace and truck alike for sight and protection.

Safety Hints

R.P.M of router bits. It is hard to set hard and fast rule for cutting speeds, but this table is a guide. Router bits over 38mm dia, Should be used in a bench mounted router machine or overhead machine. always take note of machine manufactures instructions.

Bit Diameter	Wood	Plastics	Aluminium & Non Ferrous Metals
Up to 25mm	24,000	18,000	14,000
26mm-50mm	18,000	14,000	12,000
51mm-63mm	16,000	12,000	10,000
64mm-75mm	14,000	10,000	9,000
76mm-87mm	12,000	10,000	8,000

Depth of cut and a number of passes must always be considered.

The specification that Richard Stanley PTY. LTD. incorporate in these router bits are those which have come from decades of accumulated cutting tool knowledge and

THAT IS WHY YOU SHOULD BUY
TruaCuT
PRODUCTS BY
RICHARD STANLEY PTY.LTD.
ROUTER BITS.



Multi Duct Collection Adapter
for 100-125mm Diamond Cup Wheels

HURRICANE

**Amazing dust
collection performance**
& Unique Functions

97%*

*When grinding the concrete plate by 125mm diamond cup wheel with 450W small cleaner.



Magnetic Transformation

HURRICANE can be adapted for corner grinding by simply switching the MAGNETIC front covers.



Stable & Smooth dust-free grinding near the wall !



Alternatively, the front cover can be fixed by screws.

Int'l PAT-P. 2009

SPEC

Model Code	NKC-125
Blade	100mm-125mm Diamond Cup Wheels
Weight	340g
Grinder	BOSCH GWS9-125/GWS10-125/GWS14-125, MAKITA 9558NB/9565CV, HITACHI G12SR3/G13SE2/G13SB3 ...etc.



<https://youtu.be/nVrnpOVg0mM>

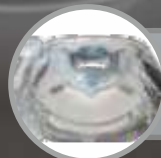

FLEX-SEAL system

With our new FLEX-SEAL system, the head is sufficiently flexible to allow a natural grinding action, yet still seals tightly to generate a strong stream into the duct, even with low-powered cleaners.

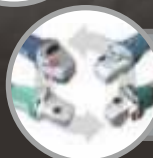

Universal Design

Exchangeable connector enables use with a wider range of Grinders.
*We continually update our products to ensure compatibility with the latest Grinders.

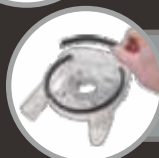

Brush Skirt

The changeable Brush is suitable for use on any surface. It prevents the dust from leaking out of the Cover.

**HYBRID Duct Collection Adapter
for 100-125mm Diamond Blades**

Tornado

**The First of its kind
in the world***

90%

Dust Off with NO Vacuum

*Researched in Jan 2009 by NAKAYA,
as an attachment for Grinders,
when cutting thick blocks
with a new 125mm diamond blade.



BEFORE



AFTER



IDS
2009
IDS Design Competition
Technical Award

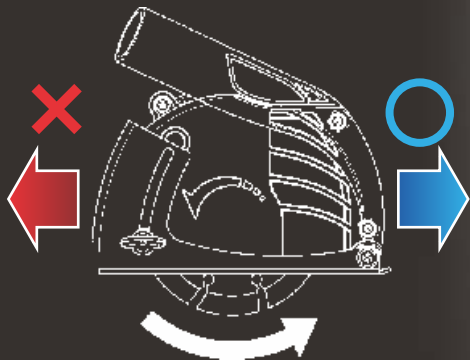

Blade Rotation

! Keep pushing FORWARD, and ensure correct blade rotation as shown in the picture to the left.

SPEC

Model Code	NK-125
Blade	125mm/T1.5-2.2 Diamond Blades.
Cut Depth	5-33mm
Weight	520g (Main Unit)
Grinder	BOSCH GWS9-125/GWS10-125/GWS14-125, MAKITA 9558NB/9565CV, HITACHI G12SR3/G13SE2/G13SB3 ...etc.

Dust Bag needs emptying with every 3m of cutting.*

*We recommend preparing a number of dust bags for efficient work.



<https://youtu.be/BMdagdwULO0>



HYBRID Dust Collection

TORNADO has 2 ways of dust collection. You can choose between the self-vacuum mode and connecting to a vacuum cleaner, which removes nearly 100% of dust.



Easy Blade Change (EBC) system

With our revolutionary EBC system, the blade can be changed with just one operation.



Universal Design

Exchangeable connector enables use with a wider range of Grinders.
*We continually update our products to ensure compatibility with the latest Grinders.



Tornado Duct

Spiral formed "TORNADO Duct" does not impede the view of the cutting line nor the space around the operation handle.

Int'l PAT-P. 2009

NEW PRODUCT

TruaCuT have released a range of Tungsten Carbide CUTTERS for fabricating ALUCOBOND® Aluminium Composite Material.

These Cutters are designed to fit machines like FESTOOL, PF1200 etc.

V-shaped or rectangular grooves are routed into the rear side of the Alucobond® composite panels with blade cutters or form bits. The aluminium cover plate on the front side and a part of the core material are left standing. The remaining material is thin enough to permit folding by hand. A folding machine is not required. The groove shape determines the bending radius.

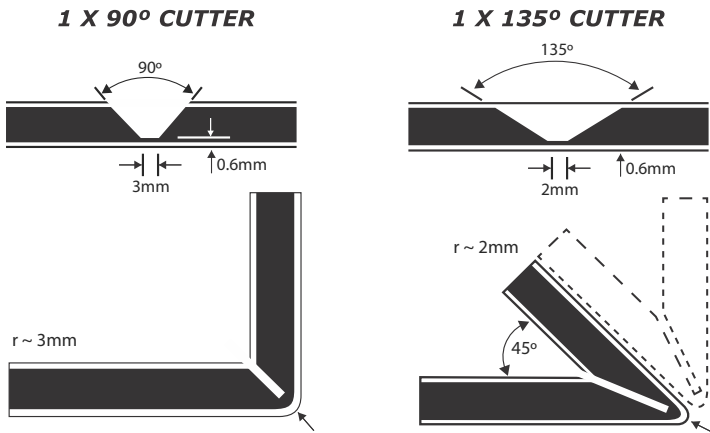

ITEM CODE	LIST PRICE + GST	DESCRIPTION	BARCODE
TC09090F		Cutter 90° to give a 90° sheet bend without distortion.	9326186009899
TC13545F		Cutter 135° to give a 45° sheet bend without distortion.	9326186009905
TCC90135F		Combination pack containing both of the above cutters	9326186009912
TLB9013545		Router Bit set 3 profiles to cut 90°, 135° & 45°	9326186009929

SIGN INDUSTRY - SHOP FITTING INTERIOR DESIGN

COMBO PACK - SPECIAL PRICE 3 TUNGSTEN CARBIDE ROUTER BITS FOR CUTTING

ALUCOBOND®

V-shaped or rectangular grooves are routed into the rear side of the Alucobond® composite panels with blade cutters or form bits. The aluminium cover plate on the front side and a part of the core material are left standing. The remaining material is thin enough to permit folding by hand. A folding machine is not required. The groove shape determines the bending radius.

Three router bits supplied in a combination pack also for cutting ALUCOBOND®. Cutting 90° & 135° & 45°. ¼" router bit shanks.

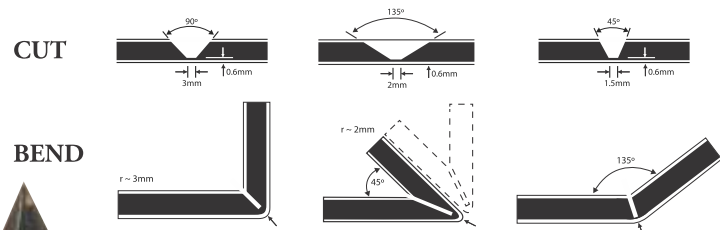

TruaCuT
PRODUCTS BY
RICHARD STANLEY PTY. LTD.

richardstanley@bigpond.com

Dust Extraction System for 180/230mm diamond blade

CE (FI) EN60745-1
EN60745-2-22
compliance.

DUST TANK

NK-230 MADE IN JAPAN



Dust generated on the construction site is a serious problem because of the damage caused to both the operatives health and to the environment.

DUST TANK is the FIRST product that controls the dust even when "plunge-cutting", and when fitted to a range of popular angle grinders.



Multi Adapting System PAT.P

Our revolutionary "Multi Adapting System" enables DUST TANK to be fitted onto a wide range of popular 230mm Angle Grinders.*

*Details on compatible models are listed in the instruction manual.



Plunge Dust Control PAT.

When plunge cutting, the Cutting Guide is automatically stored, the Front Brush then contains the dust being blown forward.*

*Max. cutting depth 40mm for effective dust extraction.

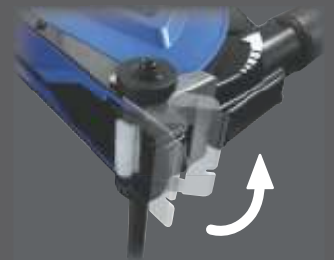

Stabilizing Bar System

Front / Rear support bars stabilize the whole system, the 6-Rollers cancel any friction against the work surface for a smooth cut.

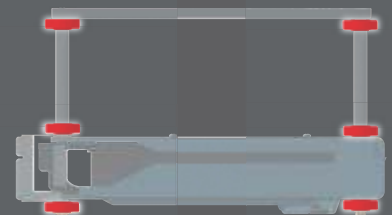

https://youtu.be/cpm3H_L_8sg





Product # TSPK124

TruaCuT

PRODUCTS BY
RICHARD STANLEY PTY. LTD.

Semi-Pro Series 12pc Router Bit Kit

- 1/4" (6.4mm) Shank
- Tungsten Carbide Tipped
- Most popular bit selection

Quality Router Bits That you Expect from

TruaCuT Semi-Pro Series.

CYCLONE

NK-125CY

- **Depth Adjustment.**
- **Easy Blade Change.**
- **Fits 99% of 125mm Angle Grinders.**



<https://youtu.be/URWBra1ehDI>

NAKAYA
JAPAN ORIGINAL TOOLS