



**TTR500 Series
Vector Network Analyzers
Demonstration Guide**



071-3493-01



**TTR500 Series
Vector Network Analyzers
Demonstration Guide**

Register now!

Click the following link to protect your product.

▶ www.tek.com/register

www.tek.com

071-3493-01

Copyright © Tektronix. All rights reserved. Licensed software products are owned by Tektronix or its subsidiaries or suppliers, and are protected by national copyright laws and international treaty provisions.

Tektronix products are covered by U.S. and foreign patents, issued and pending. Information in this publication supersedes that in all previously published material. Specifications and price change privileges reserved.

TEKTRONIX and TEK are registered trademarks of Tektronix, Inc.

Contacting Tektronix

Tektronix, Inc.
14150 SW Karl Braun Drive
P.O. Box 500
Beaverton, OR 97077
USA

For product information, sales, service, and technical support:

- In North America, call 1-800-833-9200.
- Worldwide, visit www.tek.com to find contacts in your area.

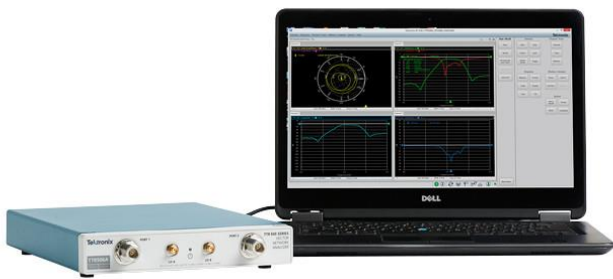

What You Will Learn

With this guide, you will explore how to use Tektronix USB vector network analyzers to

- Set up the VNA
- Make one port and two port calibrations
- Perform simple one port and two measurements on a bandpass filter.

Contents

Check List for the Demo	2
Setup	3
One-Port Calibration	4
STIMULUS SETUP	4
ONE PORT CALIBRATION (REFLECTION TEST)	5
SAVE AND RECALL CALIBRATION	6
One Port Measurements	7
RETURN LOSS	7
VSWR	7
SMITH CHART / IMPEDANCE MEASUREMENT	8
Two-Port Calibration	10
STIMULUS SETUP	10
TWO PORT CALIBRATION: 2-PORT 2-PATH SOLT	11
APPLY PORT EXTENSIONS	13
Two Port Measurements	15
TRANSMISSION/ INSERTION LOSS	15
BANDWIDTH/ CUT-OFF FREQUENCIES	16
PHASE RESPONSE	16
GROUP DELAY	17
Offline Analysis Using Touchstone SnP files	18
SAVE AND LOAD SNP FILE	18
Bias Tee Setup	19

The screenshots in this demo guide may not match the displays on your instrument due to the different instruments, devices under test, and test environments.

Check List for the Demo

Before beginning the demo, please be sure you have the following items

- Tektronix TTR500 Series Vector Network Analyzer



- 4-in-1 OSLT Compact Cal Kit (N-male) (015-0802-00)



- 60 cm N-male to N-male cables (012-1768-00)



- Type N Female to Female adapter (013-0410-00 INMET 5003)



- Type N Male to Female Adapter (013-0411-00 INMET 5005)



- 1560 to 1620 MHz BP Filter (119-8723-00 Mini-Circuits NBP-1560+)



- Type B USB 2.0 cable (174-6150-00)



Setup

1 Set up the VNA

- Connect the TTR500 to a power source using the DC adapter.
- Use the USB 2.0 cable to connect the VNA to your Windows PC. The driver files are installed automatically and the installation wizard opens.



2 Install VectorVu-PC if not previously installed.

- Follow the prompts in the installation wizard to install VectorVu-PC software. You can also download and install VectorVu-PC from www.Tek.com.
TekVISA is NOT necessary to run VectorVu-PC with TTR500.

3 Connect VectorVu-PC to the VNA

- Open VectorVu-PC.
- The software should identify and connect to the TTR500 device automatically. If this does not happen, open Connection Manager (System > More > Connection) and connect the device manually.
- The connection indicator is green when there is an active connection (or when the device is in simulator mode).

The screenshot shows the VectorVu-PC 0.8.5 simulator interface. The 'Connection Manager' window is open, displaying a table of discovered instruments. The table has columns for Name, Manufacture, Model Number, Software Version, Connection, Activation, and Availability. The 'Connect' button is highlighted with a red box. A 'Connecting ...' dialog box is also visible in the background.

Name	Manufacture	Model Number	Software Version	Connection	Activation	Availability
LONGRALL100				Disconnected	Not Activated	Not Available
TTR506A_Y010035_752B5F9D	Tektronix Inc.	TTR506A	FW000001	Disconnected	Activated	Available
simulator	tektronix inc.		0.8.5.e986574	Connected	Claimed	Available

One-Port Calibration

To reduce errors in measurement, calibrate the VNA before you use it to measure device parameters. Calibration works to minimize Systematic Errors in the test setup, maximizing measurement accuracy.

Stimulus setup

1. Start the calibration with a factory preset. Under System, click **Preset** > **OK**.
2. In **Stimulus**, set **Start** and **Stop** frequencies to 100 MHz and 4.1 GHz. Press Enter or click the checkmark to confirm your selection.

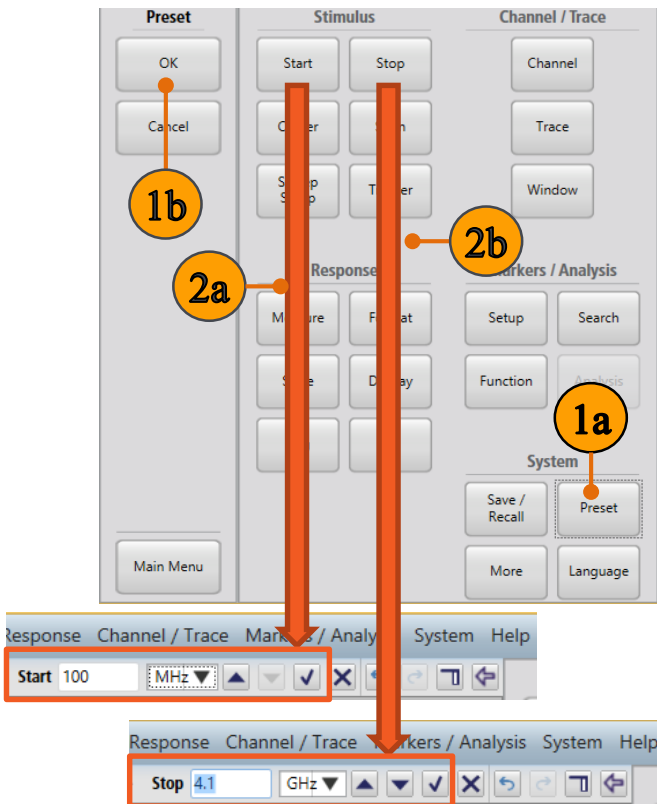

Quick tip: Frequency range

A wider range of calibration increases calibration time. However, a short range puts you at the risk of making inaccurate measurements outside your calibration range.

Quick Tip: User interface of VectorVu-PC

There are multiple ways to control VectorVu-PC. Use the  icon to expand or contract the soft key panels.

1. Full Soft Key panel

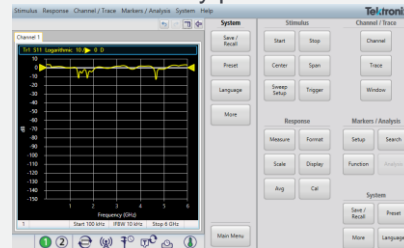

2. Compact soft key panel

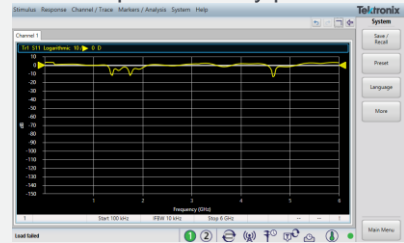

3. You can also access these menus from the menu bar.

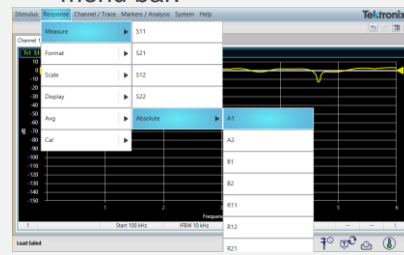

Under Stimulus, click **Sweep Setup** > **Points** and set points to 201.

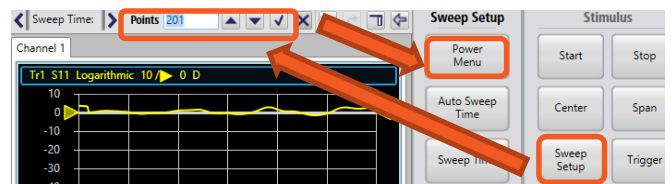

3. Under Stimulus, click **Sweep Setup** > **Power Menu** > **Power Level** and set Power level to 3 dBm

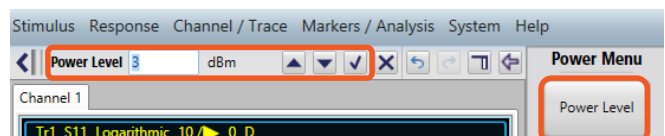

One port calibration (reflection test)

The calibration procedure fine-tunes the measurements made by a VNA by comparing measurements taken by the instrument with those taken by a known standard, in this case the Spinner 4-in-1 Cal Kit. This is a crucial step for all VNA measurements.

1. Under Response, click **Cal > Cal Kit**.
2. Select your desired calibration kit. In this example, we use **OSLT N BN533844**.

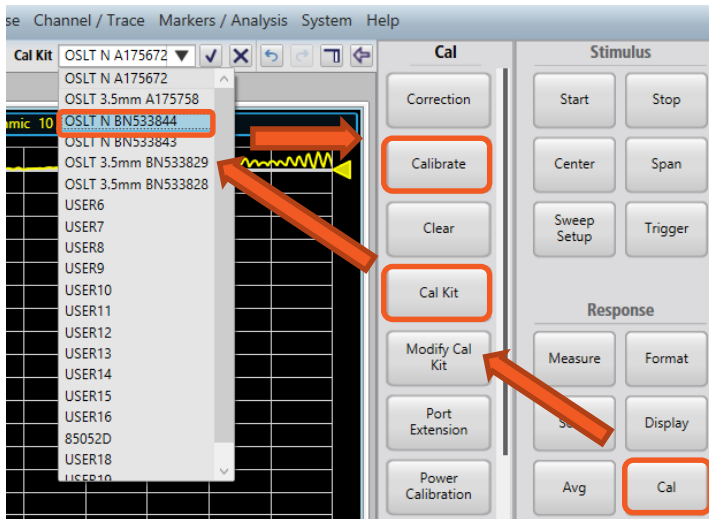

3. Under Response, click **Cal > Calibrate > 1-port SOL**.
4. Click the port you want to calibrate. In this example, we use **Port 1**.
5. In the 1-port SOL Dialog Box, select the **subclass** of the calibration kit. In this example, we use **1 - Male-Male**.

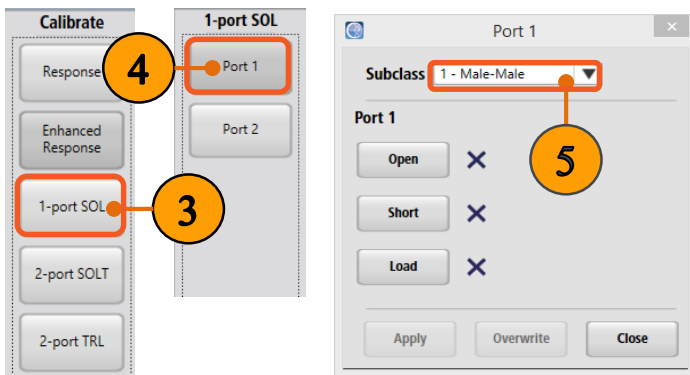

6. Connect the **Open** port of the calibration kit to Port 1 of the VNA. See the images on the right side of the page for steps 7-8.
7. In the 1-port SOL dialog box click **Open**. The VNA records a trace measurement.

8. Repeat steps 6 and 7 using the **Short** and **Load** ports of the calibration kit. See images.

When the measurement is complete, the VNA produces a beep and the instrument status bar displays . A check mark appears next to the standard measured in the port dialog box.

9. **Apply** the calibration data. The VNA creates and applies the calibration coefficients. The error correction function is also enabled.

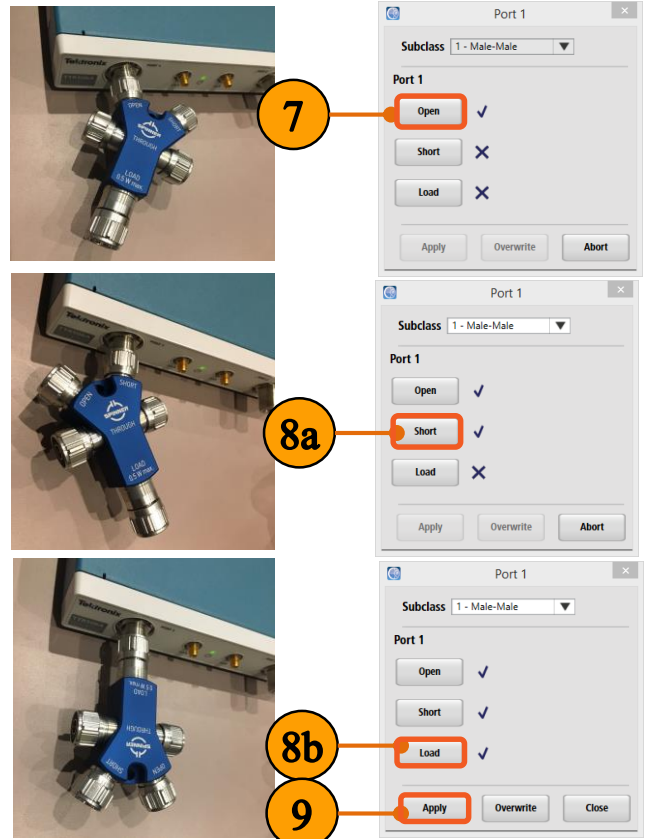

Quick Tip: Component Connection

When working with precision RF cables and connectors it is important to minimize wear on the gold center conductor pin. The best practice for connecting and disconnecting cables is to isolate the conductor and spin the barrel to secure the threads, rather than spinning the entire cable and putting added wear on the center conductor. Connections should be snug but not over-tight.

10. Disconnect the calibration kit and verify a flat 0 dB S11 response.



Save and recall calibration

To save a calibration file:

1. Under System, click **Save/Recall > Save**
2. In the Save dialog box select **State + calibration (*.cstate)** from the dropdown as the file format.
3. Click **Save** to store the calibration file.

To recall a calibration file:

4. Click **Preset > OK**.
5. Under System, click **Save/Recall > Recall**.
6. In the Recall dialog box navigate to the saved .cstate file and click open to recall saved state.

Quick Tip: Limitations when recalling data

- Calibration and state information are unique to an individual VNA at a particular time and in a specific environment. You cannot share calibration data (*.cstate files) between different units.
- The data saved in a VNA is specific to the environment of the instrument. When you recall the saved state of an instrument (*.state or *.dstate file) and reinstate these settings, the VNA can behave differently if the operating conditions have changed since the time the information was saved.

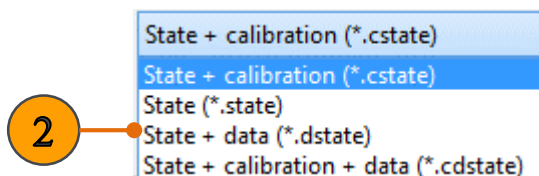
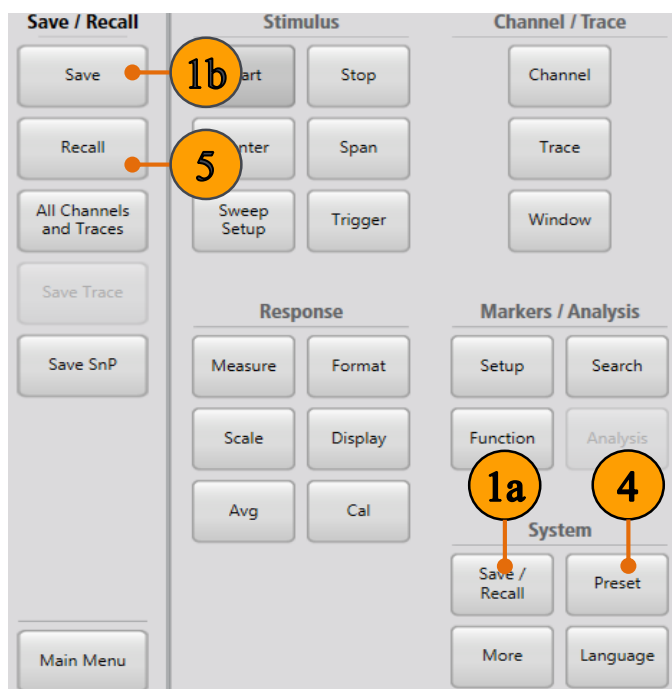

One Port Measurements

Return Loss

Return loss is a linear reflection measurement. Lower return loss is better when designing a circuit intended to transmit signals. This is important for RF components, such as mixers, filters, and amplifiers. In this example, we use the band pass filter (Mini-Circuits 15542) provided in the demo kit.

1. Either continue from the last example, or recall [One_Port_Cal.state](https://danahertm.box.com/v/TTR500DemoFiles) from: <https://danahertm.box.com/v/TTR500DemoFiles>

2. Connect the device under test to Port 1 of the VNA as depicted below:

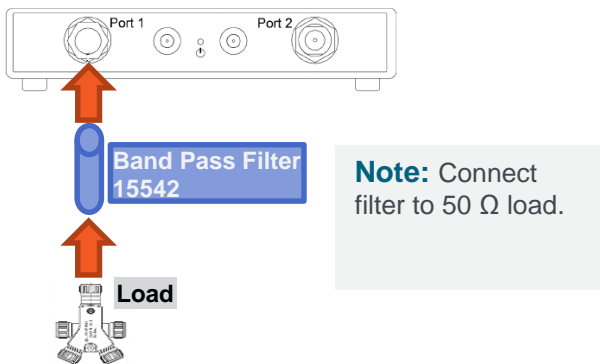

3. Under Response, click **Scale > Auto Scale**.

The return loss (S11 Log Mag) of the filter should be displayed on Trace 1 with a passband roughly between 1.3-1.8 GHz as shown below:

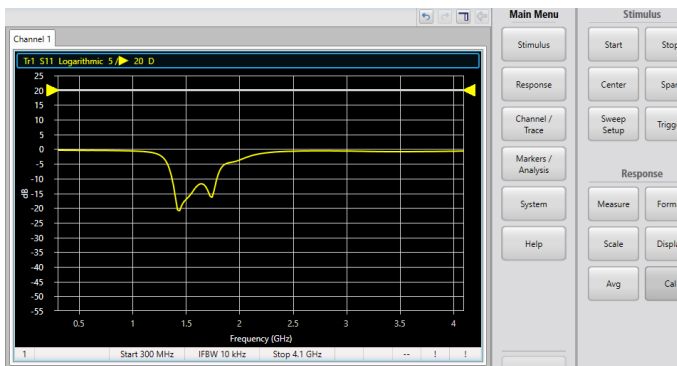

4. Under Markers/Analysis, click **Setup > Marker 1**.

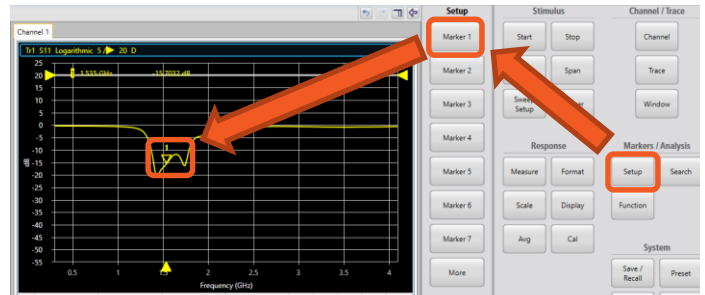

5. **Click and drag** to move the marker on the display to answer these questions:

- What is the approximate return loss at the center of the passband?
- At what frequency is the magnitude of return loss the greatest?

VSWR

The 1-port Measurement data can also be displayed linearly as Voltage Standing Wave Ratio (VSWR), which is the ratio of Forward/Reflected vs frequency.

1. Continue from the last example, or recall [Return_Loss.state](https://danahertm.box.com/v/TTR500DemoFiles) from: <https://danahertm.box.com/v/TTR500DemoFiles>
2. Under Channel/Trace, click **Trace > Trace Layout** and select **D1_2** as the layout.
3. Under Channel/Trace, click **Trace > Num Traces** and select **2** as the number of traces. The second trace appears as shown below:

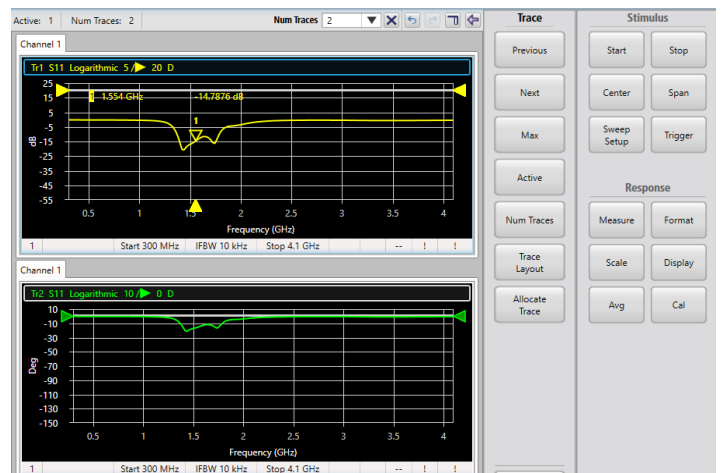

- Click on the title of **Trace 2** to select it. It will be outlined in blue once selected.

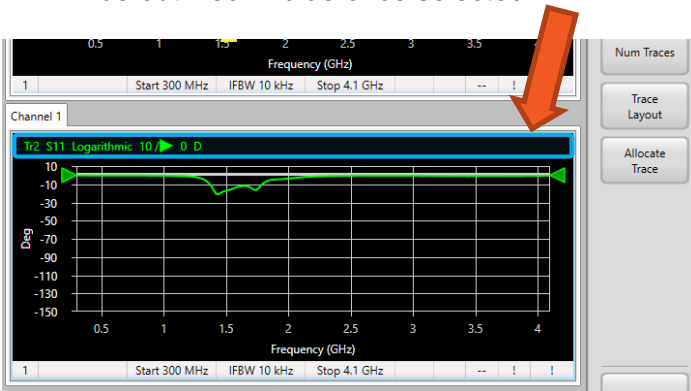

- Under Response, click **Format > SWR**



- Click **Scale > Auto Scale**. Now you can see the SWR measurement displayed in the bottom display as shown below.

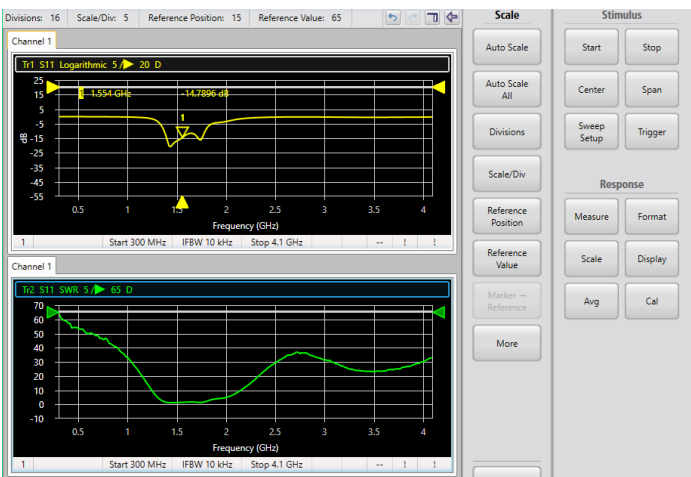

- With **Trace 2** selected, under Markers/Analysis, click **Setup > Marker 1**.

- Click and drag to move the **marker** on Trace 2 to answer the following questions:

- What is the SWR at the passband?
- What is the SWR at 3 dB return loss?

Smith Chart / Impedance measurement

The Smith chart maps reflection coefficients of measurement data from the DUT to normalized impedances. Frequencies are indicated by markers.

- Continue from the last example, or recall [VSWR.state](https://danahertm.box.com/v/TTR500DemoFiles) from: <https://danahertm.box.com/v/TTR500DemoFiles>
- Click the title of **Trace 2**. Under Response, click **Format > More > Smith > R+jX**.

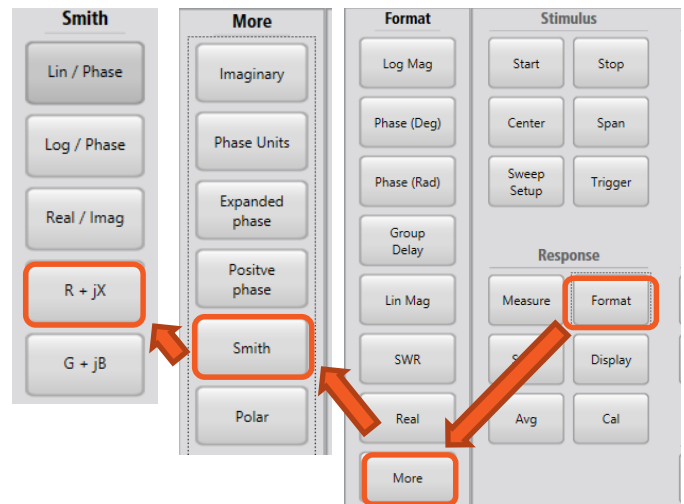

Now you can see the smith chart in trace 2 with the impedance displayed.

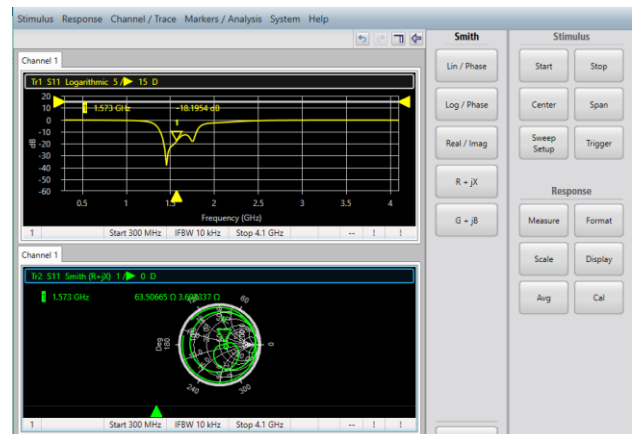

- Click on the title of **Trace 1** to select it. It will be outlined in blue once selected.
- Click and drag** the marker on trace 1 to see the impedance change on trace 2, outlined in red below.

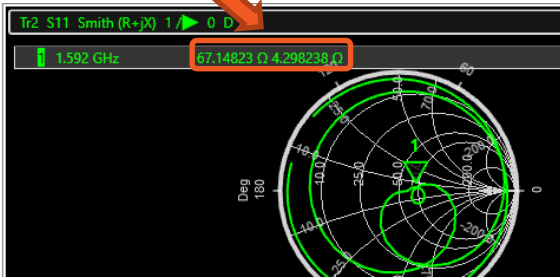

- With Trace 1 selected, under Markers/ Analysis, click **Search**.
- Click **Max** to search the frequency point with the max return loss. Observe the impedance readout of the marker on Trace 2.
- Click **Min** to search the frequency point with the minimum return loss. Observe the impedance readout of the marker on the Smith Chart on Trace 2.

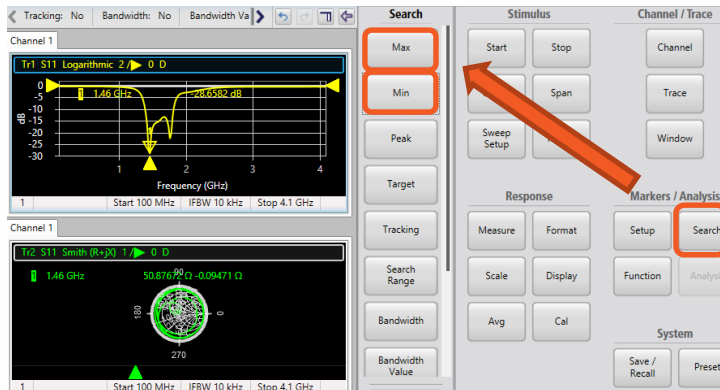

Quick Tip: Invert Color/ Ink Saver Mode

You can print screen images with a white background. Under Response, click **Display > Invert Color** and select **Invert** to change the background color from black to white.

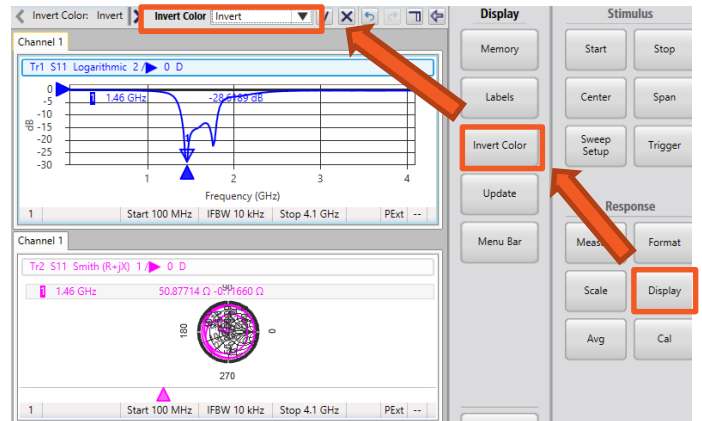

Two-Port Calibration

To reduce errors in measurement, calibrate the VNA before you use it to measure device parameters. Calibration works to minimize Systematic Errors in the test setup, maximizing measurement accuracy.

Stimulus setup

1. Start the calibration with a factory preset. Under System, click **Preset** > **OK**.
2. In **Stimulus**, set **Start** and **Stop** frequencies to 100 MHz and 4.1 GHz. Press Enter or click the checkmark to confirm your selection.

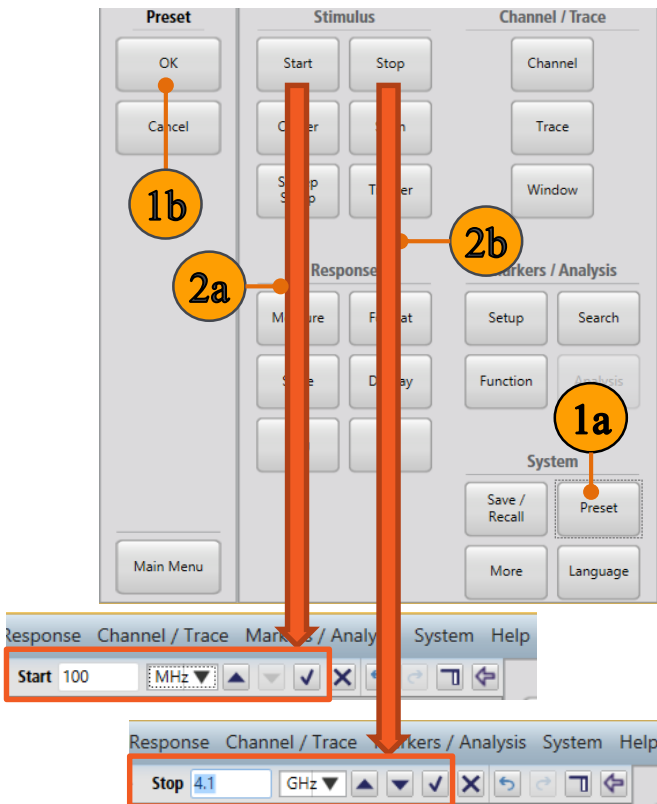

Quick tip: Frequency range

A wider range of calibration increases calibration time. However, a short range puts you at the risk of making inaccurate measurements outside your calibration range.

Quick Tip: User interface of VectorVu-PC

There are multiple ways to control VectorVu-PC. Use the  icon to expand or contract the soft key panels.

4. Full Soft Key panel

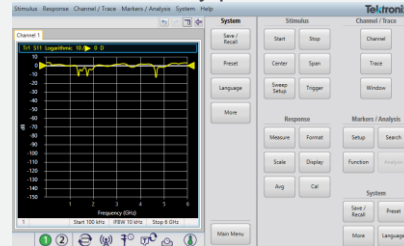

5. Compact soft key panel

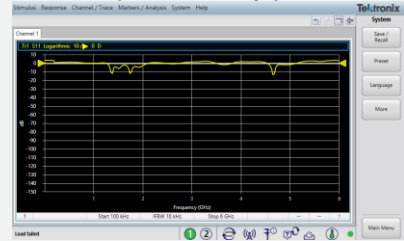

6. You can also access these menus from the menu bar.

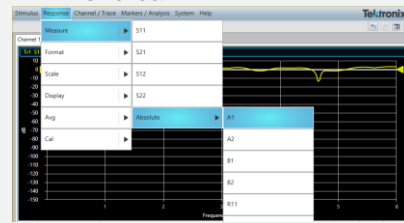

3. In Stimulus click **Sweep Setup** > **Points** and set points to **201**.

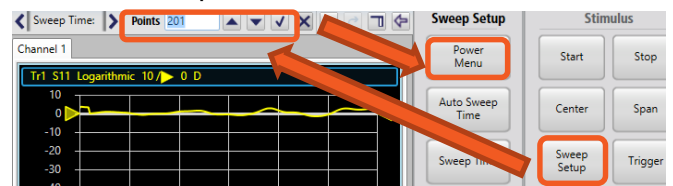

4. From Sweep Setup click **Power Menu** > **Power Level** and set Power level to **3 dBm**

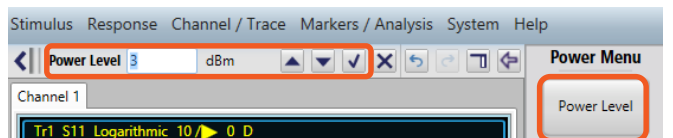

Two port calibration: 2-port 2-path SOLT

The 2-Port calibration is an Open, Short, Load and Thru measurement on both ports.

1. Under Response, click **Cal > Cal Kit**. Select the **OSLT N BN533844** cal kit.
2. Under Response, click **Cal > Calibrate > 2-port SOLT**. The 2-Port SOLT dialog box pops open.
3. Connect the **Open** port of the calibration kit to Port 1 of the VNA. See the image below.
4. In the 2-Port SOLT dialog box, click **Open** under Port 1. The VNA records a trace measurement.

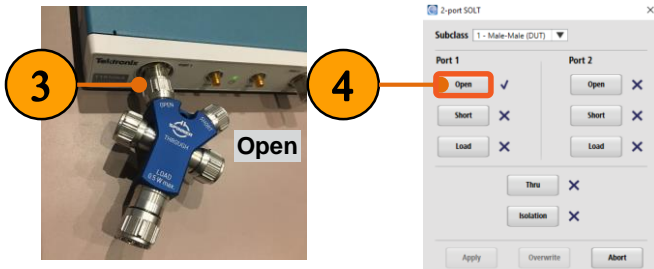

5. Connect the **Short** port of the calibration kit to Port 1 of the VNA. See the image below.
6. In the 2-Port SOLT dialog box, click **Short** under Port 1.

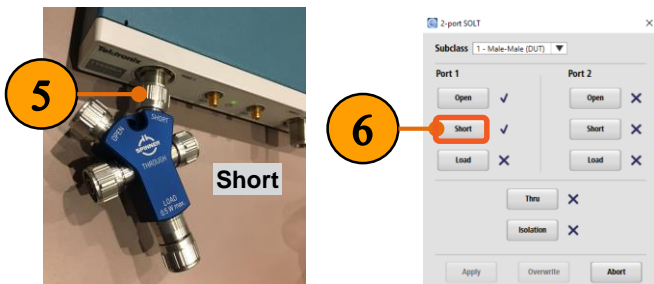

7. Connect the **Load** port of the calibration kit to Port 1 of the VNA. See the image below.
8. In the 2-Port SOLT dialog box, click **Load** under Port 1.

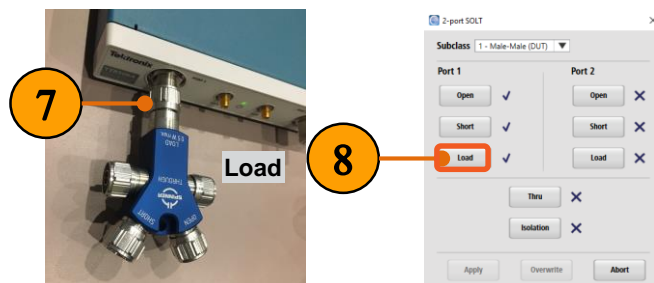

9. Connect the N-type **cable** provided in the Demo Kit to Port 2.
10. Connect the **N(f) to N(f) adapter (INMET 5003)** to the other end of the N-type cable.
11. Connect the **Open** port of the calibration kit to the other end of the N(f) to N(f) adapter, as depicted below.
12. In the 2-Port SOLT dialog box, click **Open** under Port 2.

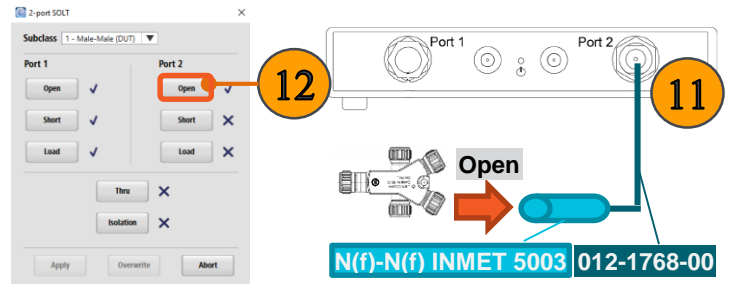

13. Connect the **Short** port of the calibration kit to other end of the N(f) to N(f) adapter, as depicted below.
14. In the 2-Port SOLT dialog box, click **Short** under Port 2.

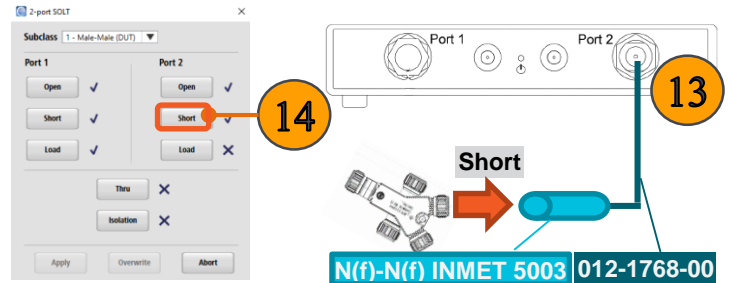

15. Connect the **Load** port of the calibration kit to other end of the N(f) to N(f) adapter, as depicted below.
16. In the 2-Port SOLT dialog box, click **Load** under Port 2.

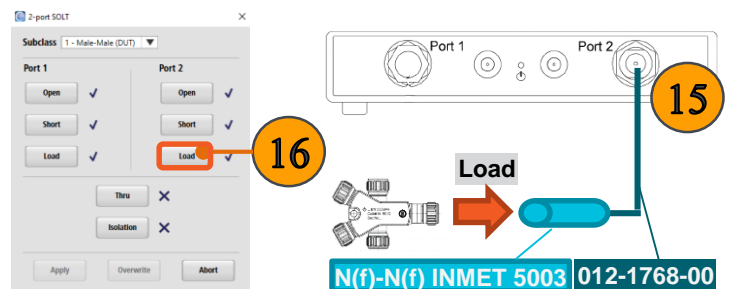

17. Connect the **Thru** standard of the calibration kit between Port 1 and the N(f) to N(f) adapter, as depicted below.
18. In the 2-Port SOLT dialog box, click **Thru**.
19. Click **Apply**. The 2-Port SOLT calibration is now complete.

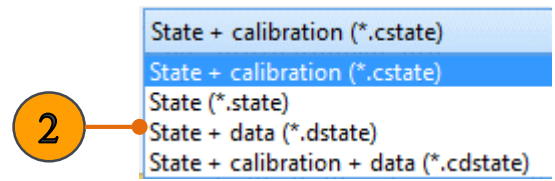
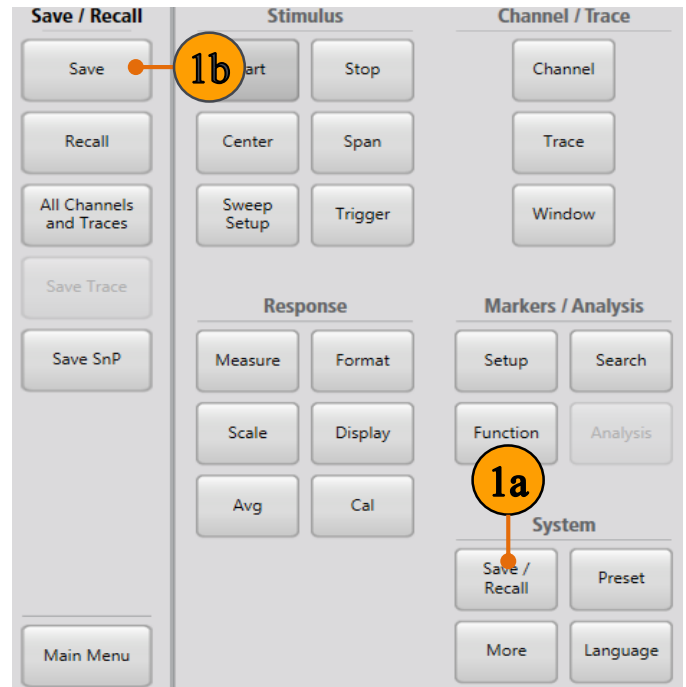
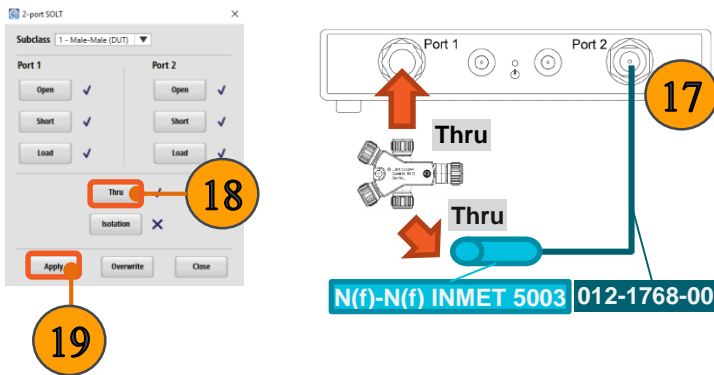

Isolation Calibration

The isolation calibration process is removes the errors due to crosstalk between test ports in a transmission measurement (S_{21}/S_{12}). Crosstalk can be a problem when testing high dynamic range devices such as filters with a high level stopband. In a two-port calibration, you have the option to omit the isolation calibration. Since the Demo Kit does not contain the required amount of load standards to perform this step, it is omitted here.

Please refer to the TTR500 User Manual for more information.

Save calibration

To save a calibration file:

1. Under System, click **Save/Recall > Save**
2. In the Save dialog box select **State + calibration (*.cstate)** from the dropdown as the file format.
3. Click **Save** to store the calibration file.

Quick Tip: Limitations when recalling data

- Calibration and state information are unique to an individual VNA at a particular time and in a specific environment. You cannot share calibration data (*.cstate files) between different units.
- The data saved in a VNA is specific to the environment of the instrument. When you recall the saved state of an instrument (*.state or *.dstate file) and reinstate these settings, the VNA can behave differently if the operating conditions have changed since the time the information was saved.

Apply Port Extensions

In some cases, you may need to apply a port extension to compensate for connection changes going from the user calibration to the measurement setup. For example:

- The DUT may be in a test fixture.
- The port gender for the cal kit may be different from the DUT's.
- You performed a calibration but need to add a length of transmission line to the test setup.

Port extension is a function usually done after a user calibration. It compensates for the phase response change that occurs when the calibration reference plane is not the same as the measurement plane of the DUT. In this example, we use port extensions to compensate for the difference in length between the N(f)-N(f) adaptor (used in calibration) and the N(f)-N(m) adaptor (used for the filter measurements).

Due to the electrical length difference between the N(f) to N(f) adaptor used during the calibration and the N(f) to N(m) adaptor we will use to make two port measurements, the phase response is not completely flat at 0 degrees. An additional calibration step, known as port extension, must be performed to remove the linear portion of the phase response.

1. Continue from the last example.
2. Remove the Cal kit and the N(f) to N(f) adaptor from the test setup.
3. Connect the **N(f) to N(m)** adaptor between port 1 of VNA and the other end of the cable.

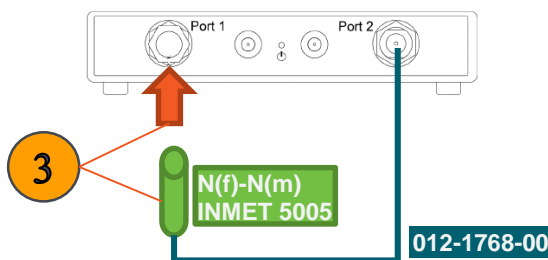

4. Click on the title of **Trace 2** to select it. It will be outlined in blue once selected.

5. Under Response, click **Format > Phase (Deg)** to measure the Phase (Deg) response of S21.

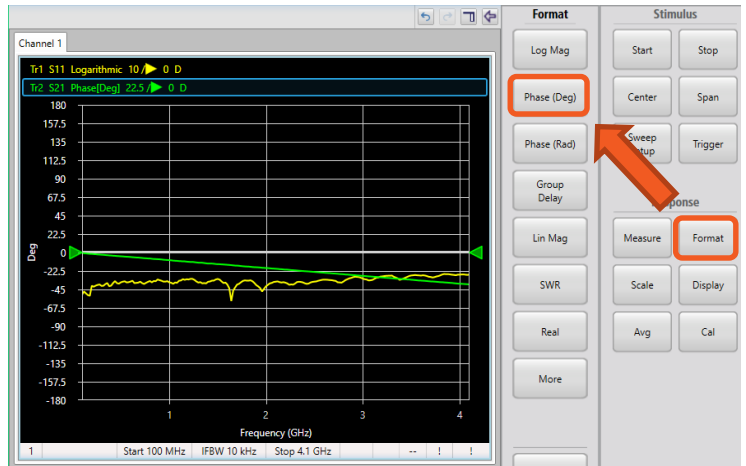

Note that the phase response of S21 without any DUT is linear, but not completely flat (0 degrees).

6. With Trace 2 selected, click **Format > Group Delay**.
7. Under Response, click **Scale > Auto Scale**.
8. Under **Response**, click **Avg > Enable Smoothing**.
9. Estimate and record the average group delay. In this example, it is about 25 ps.

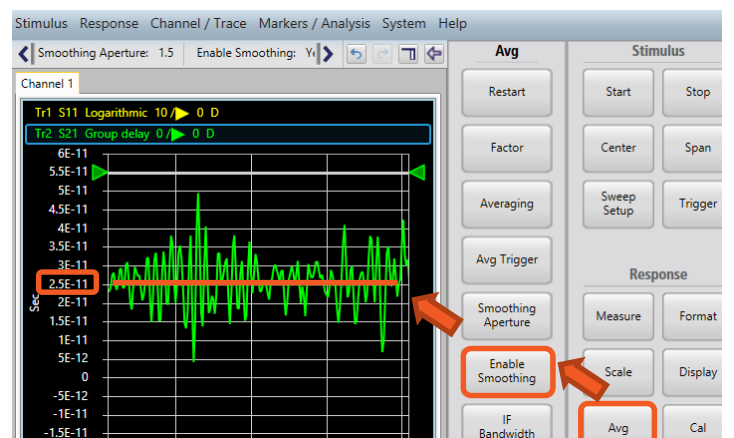

10. Under Response, click **Cal > Port Extension**.

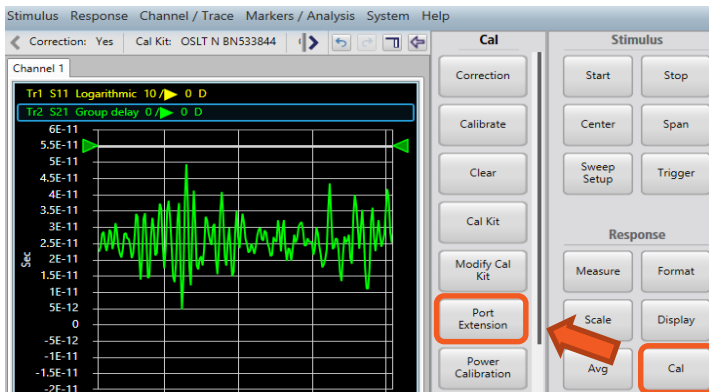

11. Enter the group delay measured in Step 9 as the **Delay Time** of Port 1.

12. Check **Enable Port Extension**, and click **OK** to apply settings.

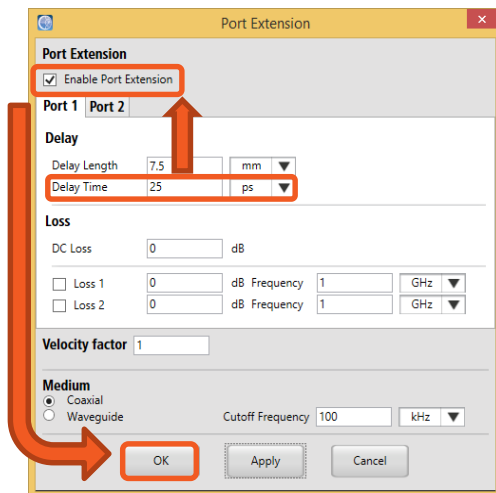

Note: Once the port extension is applied, the group delay of S21 should be close to zero.

13. Click **Format > Phase (Deg)**, the phase response of S21 should be a flat 0° response.

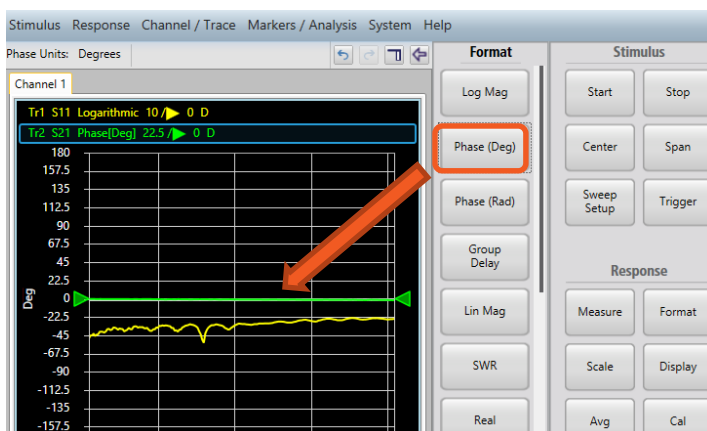

Two Port Measurements

Transmission/ Insertion Loss

Insertion loss is often used to describe the characteristics of a filter. It is usually considered to be the same as the inverse of the log magnitude format of S21. The value of insertion loss is usually a positive number.

1. Continue from the last example.
2. Attach the male end of the filter to Port 1 and attach the female end of the filter to the cable on Port 2. Use the male-to-female adapter included in the demo kit.

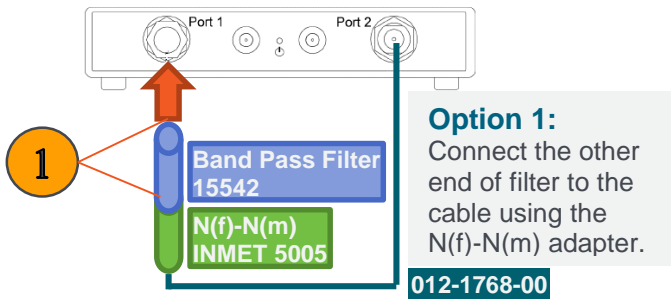

3. Under Channel/Trace, click **Trace > Num Traces** and set the number of traces to 1 to see only Trace 1.
4. Click the title of **Trace 1**.
5. Under Response, click **Measure**. Select **S21** as the measurement.

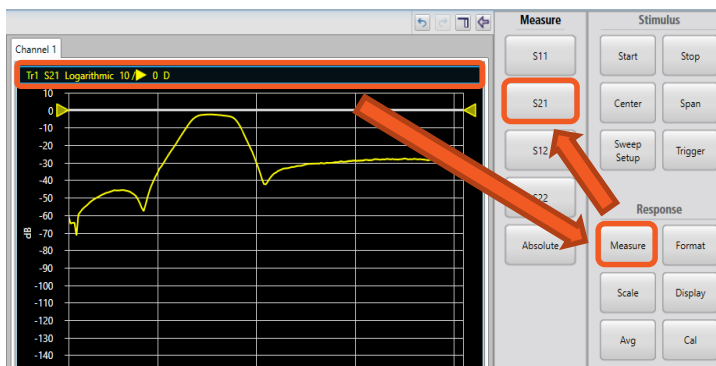

6. Under Response, click **Scale > Auto Scale**.

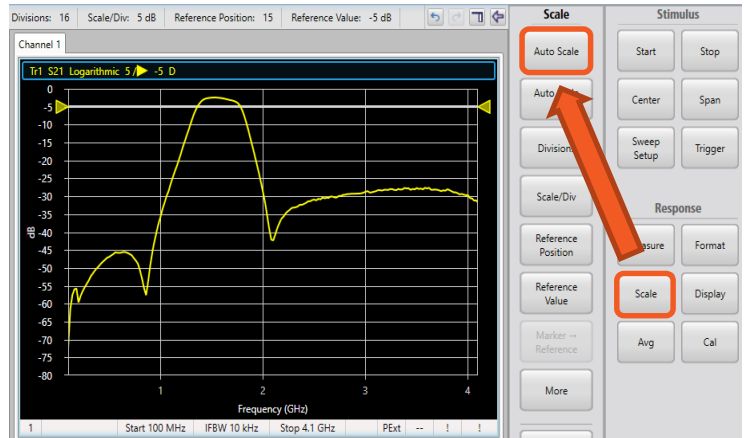

What is the type of this filter? (bandpass, low pass, high pass?)

7. Under Markers/Analysis, click **Setup > Marker 1**.
8. Move the **Marker** to measure insertion loss at the pass band.
9. Set the **Start** frequency to **850 MHz** and the **Stop** frequency to **2450 MHz** to zoom in.

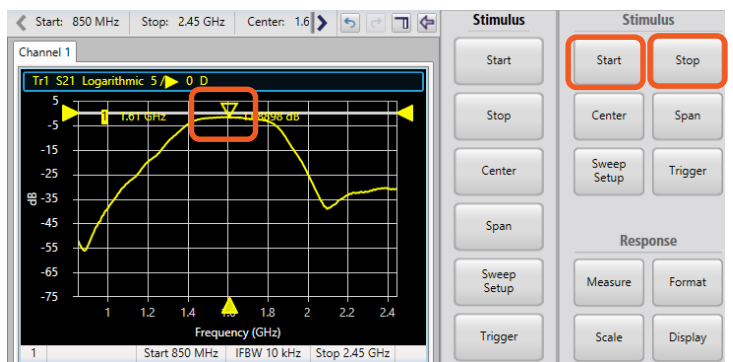

Bandwidth/ Cut-off Frequencies

In VectorVu-PC, you can perform a bandwidth search to determine the bandwidth of a trace, and identify the parameters associated with a stopband or passband.

1. Continue from the last example.
2. Click **Search** under Markers/Analysis.
3. Click **Bandwidth** to make the bandwidth measurement automatically.

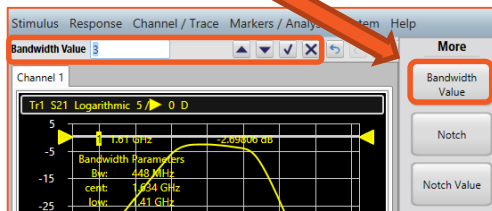
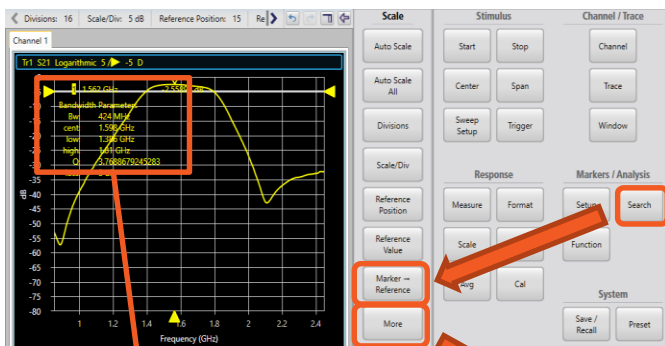

Bandwidth Parameters	
Bw:	448 MHz
cent:	1.634 GHz
low:	1.41 GHz
high:	1.858 GHz
Q:	3.64732142857143
loss:	3 dB

4. You can also click **More > Bandwidth Value**, to define a measurement bandwidth. In this example, we use **3 dB**.

The VNA will display high and low frequencies, the center frequency, bandwidth, insertion loss, and Q value in the upper left corner of the trace window.

Phase Response

For components with free linear distortion, other than observing the magnitude response, phase response is also a very important measurement. The phase response must be linear over the desired transmission bandwidth.

1. Continue from the last example.
2. Under Channel/Trace, click **Trace > Num Traces** and set the number of traces to 2.
3. Under Channel/Trace, click **Trace > Trace Layout** and select **D1_2** as the layout.
4. Under Markers/Analysis, click **Search > Bandwidth** to turn off the Bandwidth measurement, and click the title of **Trace 2**.
5. Under Response, click **Measure > S21**.

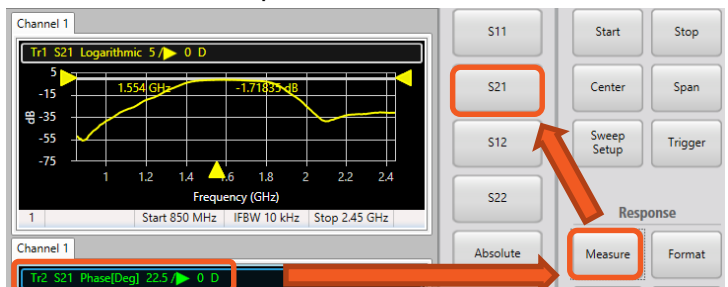

6. Under Markers/Analysis, click **Setup > Marker 1**.
7. Under Response, click **Format > Phase (Deg)**.

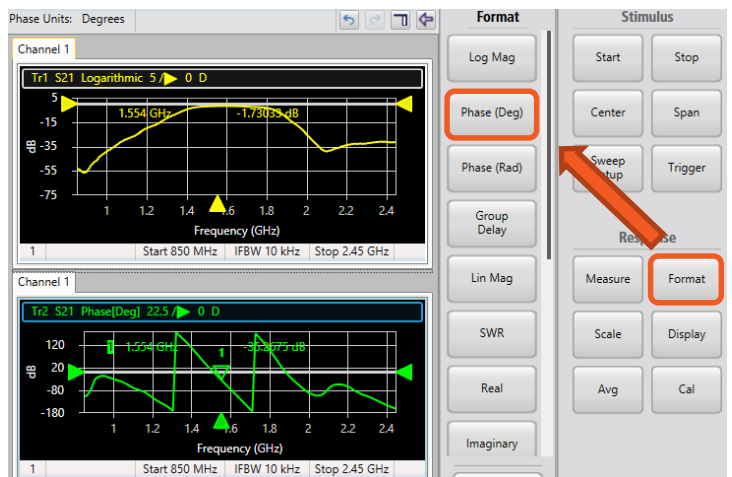

How does the general shape of the phase response correlate with the magnitude response shown above?

Group Delay

Group delay is the time delay measuring the phase distortion of RF components. Ideally, all frequencies present in the signal should have the same time delay so that the signal will not be distorted.

1. Continue from the last example.
2. Click the title of **Trace 1**.
3. Under Response, click **Format**.
4. Select **Group Delay** as the measurement format.

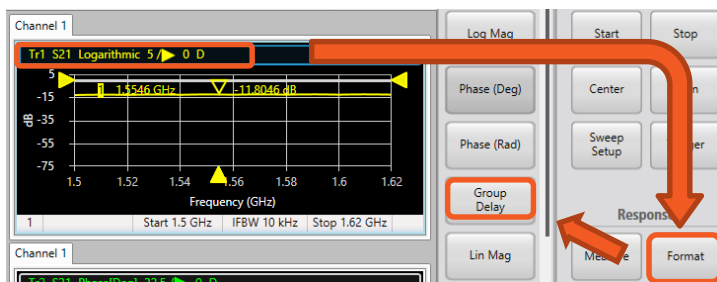

5. Under Response, click **Scale > Auto Scale**.

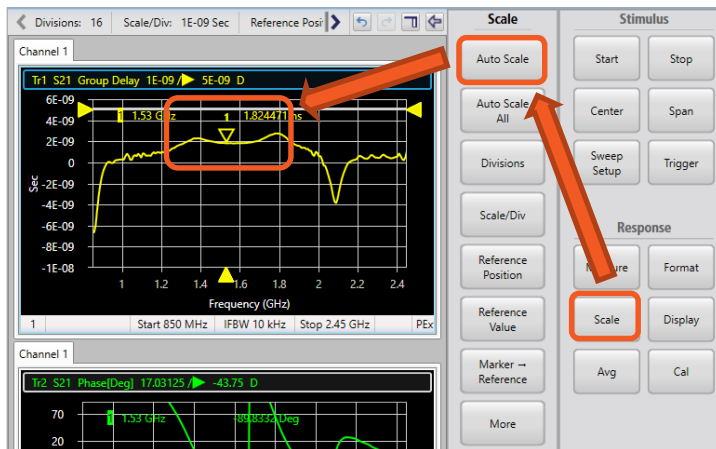

6. Observe the average group delay to answer the following questions:
 - How would you specify this filter in terms of the group delay across the passband?
 - Group delay across passband = ____ ns

7. Under Response, click **Avg**.
8. Click **Smoothing Aperture**, and enter **20** as the aperture value.
9. Click **Enable Smoothing**. Observe the difference after applying the large aperture smoothing.

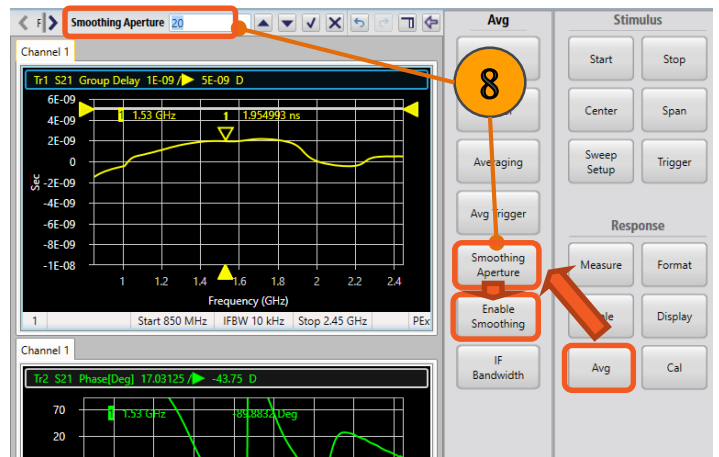

Group delay aperture

Increasing the aperture of the group delay smoothing settings makes the measurement less susceptible to noise, but reduces the resolution of the group delay measurement. The minimum aperture is equal to the frequency span divided by the number of points minus one.

Offline Analysis Using Touchstone SnP files

Save and Load SnP File

You can save s-parameter information from the VNA for 1–port and 2–port models in the touchstone format. Touchstone files contain the s-parameters of the DUT in a space-separated format. The number of ports used in the measurement determines the matrix of s-parameters for the DUT and consequently the format of the touchstone file.

Save SnP File

1. Under System, click **Save / Recall**.
2. Click **Save SnP**.
3. Select the format of the touchstone file (S1P or S2P). In this example, we save the file as **S2P**.

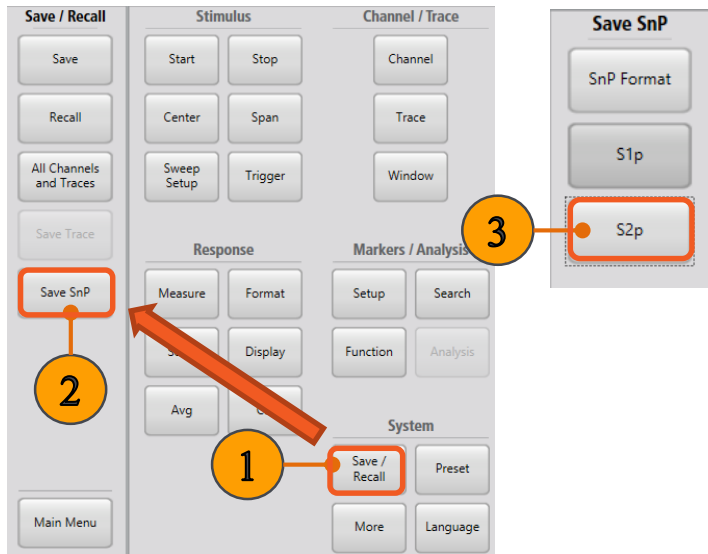

4. Save the file. Go to the folder location and open the saved file as a text file. Observe the header and S-parameters in the file.

```

TTR506A,Tektronix Inc.,Y010035,Application version 0.8.5.e986574 Firmware version F000001
# Hz S R1 R  S0
1e+08 -0.88134299 -0.41131586 -0.00020497254 0.1289492e-05 -0.00015339653 6.281492e-05 0.97815482 -0.21887555
1.2e+08 -0.84168298 0.48305842 -0.00019281752 0.2453511e-05 -0.00028159097 0.00014733778 0.96955561 -0.26070847
1.4e+08 -0.79594163 0.55891175 -0.00032388943 0.00017145596 -0.00039967446 0.00018842988 0.95781634 -0.30213987
1.6e+08 -0.74512816 0.61537548 -0.00041203159 0.00026617078 -0.00048811616 0.0003874561 0.94336595 -0.34172828
1.8e+08 -0.68999791 0.67371642 -0.00051847453 0.00035026116 -0.00052384155 0.00041164302 0.92871519 -0.38094155
2e+08 -0.63681774 0.73567049 -0.00060769832 0.00042102039 -0.00061221331 0.00070985298 0.91473918 -0.41972889
2.2e+08 -0.57329061 0.79560207 -0.00069348938 0.00047228777 -0.00076796533 0.00086806754 0.89594187 -0.45672246
2.4e+08 -0.50344563 0.82739514 -0.0011247078 0.0010742602 -0.000897967 0.00096411454 0.87656412 -0.49320964
2.6e+08 -0.43025995 0.86674842 -0.0011825868 0.0010799182 -0.0010033134 0.0014516853 0.85520509 -0.52783866
2.8e+08 -0.3567496 0.89888751 -0.0011680133 0.001159754 -0.00096820516 0.0014794815 0.83387279 -0.56032604
3e+08 -0.27989569 0.92442836 -0.001226248 0.0011606644 -0.001151898 0.0017439059 0.81296603 -0.59146519
3.2e+08 -0.20051205 0.94469081 -0.001199808 0.0011227959 -0.0009952156 0.0018770188 0.79170195 -0.622315476
3.4e+08 -0.12091698 0.95525793 -0.0010182971 0.002128893 -0.0011234843 0.0023488068 0.76847296 -0.65083654
3.6e+08 -0.039369304 0.96246819 -0.00092932757 0.0026540023 -0.0012178049 0.0027891754 0.74587843 -0.67633443
3.8e+08 0.041131932 0.96286509 -0.00085474798 0.0027463171 -0.00099380514 0.0027234156 0.72260772 -0.70214295
4e+08 0.12314808 0.95439704 -0.00039571896 0.0033293369 -0.0011549286 0.003083474 0.69607015 -0.72586813
4.2e+08 0.20822299 0.94025564 -0.00066261264 0.0033970701 -0.00070123952 0.0031631645 0.67166985 -0.74893686
4.4e+08 0.2817167 0.91833774 -0.00068604974 0.003931378 -0.00064941017 0.0036585629 0.64611463 -0.77073033
4.6e+08 0.33878357 0.89195094 -0.00068052893 0.0042863112 -0.0004599667 0.0038316473 0.61970686 -0.79089943
4.8e+08 0.43287912 0.85868437 -0.00055902052 0.0046398458 -0.00036290471 0.00408563526 0.59540113 -0.81017674
5e+08 0.50343272 0.81860422 -0.0003833562 0.004575918 2.2291715e-05 0.0042751633 0.57181241 -0.82858887
5.2e+08 0.5712244 0.7719272 0.00028308343 0.0044923263 5.0594586e-05 0.0046626991 0.54777976 -0.84478402
5.4e+08 0.61615432 0.7205221 0.000137048 0.0044317048 0.000282154 0.0046690138 0.52390615 -0.86031388
5.6e+08 0.64841875 0.66313162 0.00048444992 0.0047786781 0.0006818053 0.0047275744 0.50020516 -0.87288273
    
```

Touchstone file format

- In a touchstone file, the behavior of the DUT is completely represented by the collection of its S-parameters. You can import the touchstone file into a data modeling program or circuit simulator like MATLAB.
- In order to save all the S-parameters, you first need to run the calibration of the desired port(s). For example, to save the S2P file, a full 2-port 2-path calibration needs to be performed first. Once the calibration is complete, run any measurement you like, and the S-parameters will be able to be saved to an S2P file.

Load SnP File

5. Under System, click **More**.
6. Click **Connections**.
7. In the Connection Manager, select the **simulator**, and click **Connect** to use the offline S2P file in VectorVu-PC.
8. Under System, click **More**.
9. Click **Simulator**.
10. Click **Load SnP** and open the S2P file.

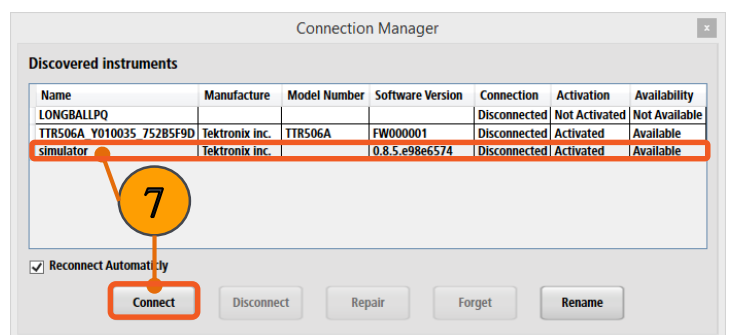
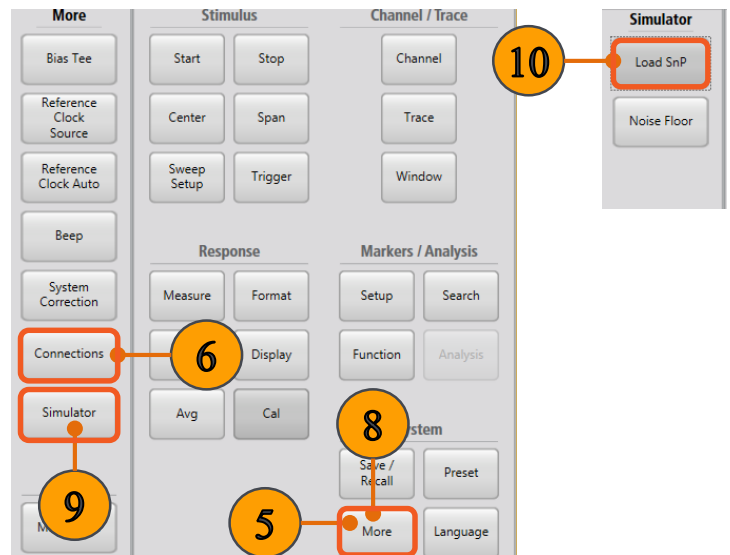

Bias Tee Setup

Sometimes measuring active DUTs requires a DC bias voltage. With the TTR500, a DC bias can easily be fed through the bias tee inputs located on the rear panel. The DC voltage is supplied to the DUTs via the inner conductor of the VNA and can be supplied to either port. This is very useful when both DC and RF signals must be applied to a DUT, eliminating the need for external bias tee circuitry.

The figures below show the simplified power amplifier test setup with and without using the internal bias tee of the VNA.

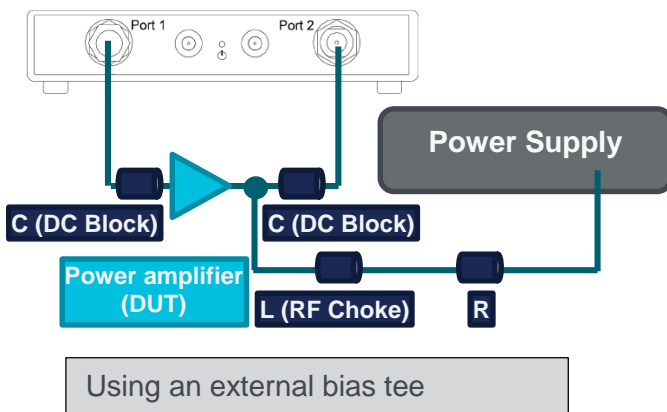
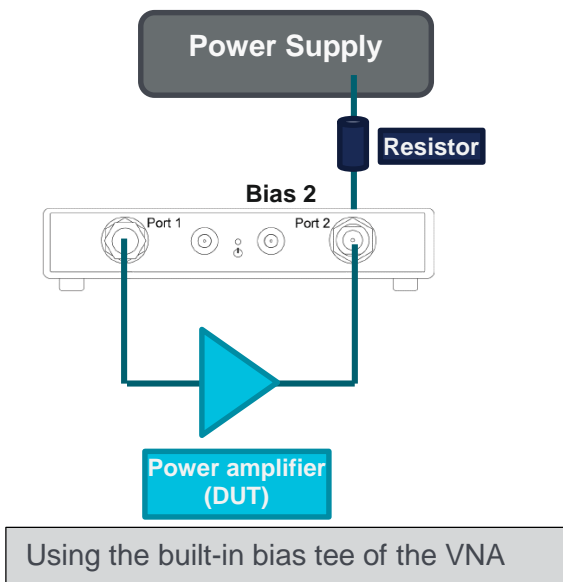

To Turn on the Bias Tee,

1. Under System, Click **More > Bias Tee**. The warning popup should appear.

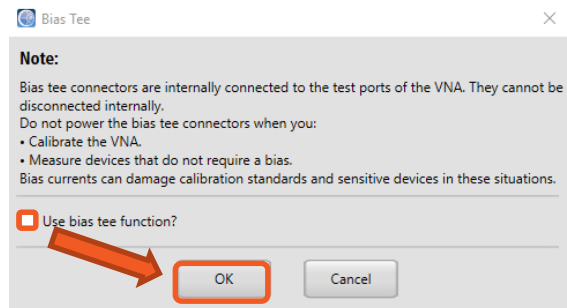
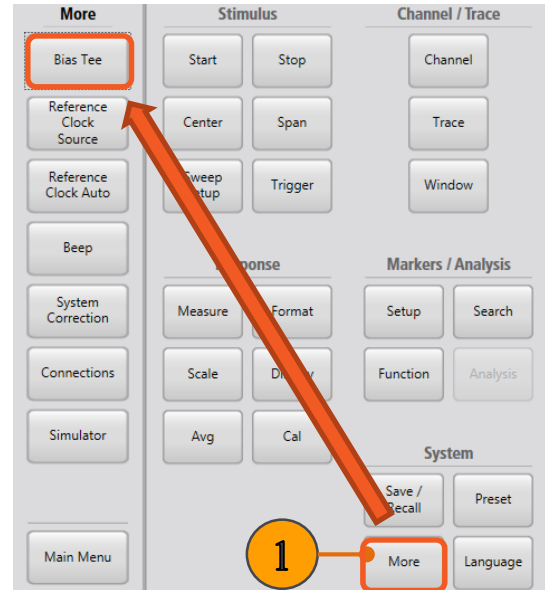

2. After you have read and followed the directions outlined in the popup window, select the box and click **OK**.

The bias tee is now able to source power to either port 1 or port 2.