

# TUBELITE®

**DEPENDABLE**

**LEADERS IN ECO-EFFICIENT STOREFRONT,  
CURTAINWALL AND ENTRANCE SYSTEMS**

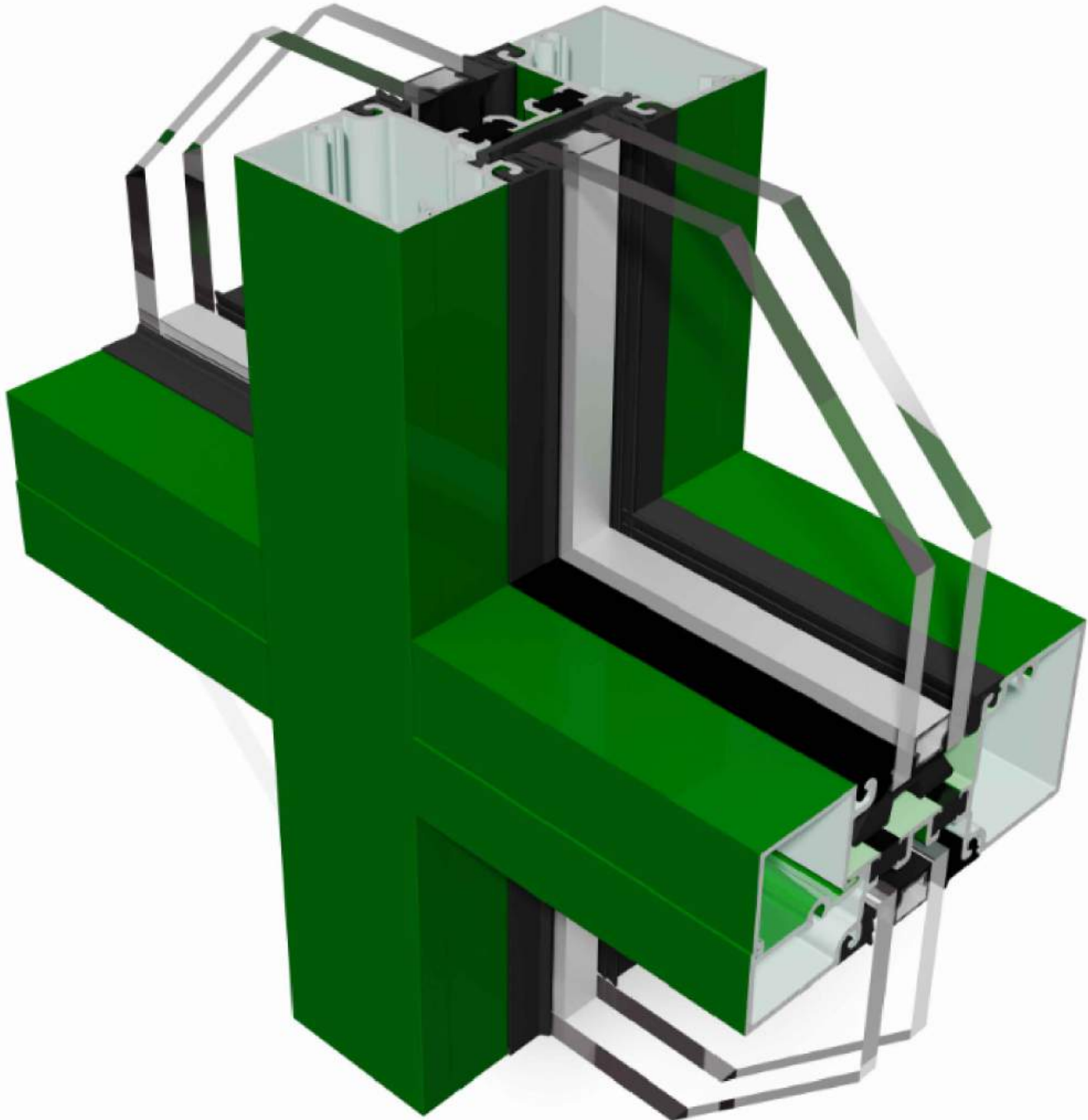

**TU24000 SERIES STOREFRONT**

## **INSTALLATION INSTRUCTIONS**

3056 Walker Ridge Dr. NW, Suite G • Walker, MI 49544 • 800-866-2227





# TABLE OF CONTENTS

GENERAL CONSTRUCTION NOTES.....	3
PARTS LIST.....	4-8
QUICK REFERENCE CHECKLIST.....	9
ELEVATION TYPES and DETAILS.....	10-13
<b>FRAME FABRICATION</b>	
Step 1 Determine Frame Size.....	14
Step 2 Cut Material to Size.....	15
Step 3 Fabricate Sill Flashing.....	16
Step 4 Fabricate Verticals & Close Pockets for Horizontals.....	17
Step 5 Fabricate Horizontal Members for Shear Blocks.....	18
Step 6 Fabricate Shear Blocks.....	19
Step 7 Steel Stiffener.....	20
<b>FRAME ASSEMBLY</b>	
Step 8 Install Sill Flashing End Dams.....	21
Step 9 Optional High Sidelite Base.....	22-24
Step 10 Assemble Frames.....	25-27
Step 11 Install Gaskets.....	28
<b>FRAME INSTALLATION</b>	
Step 12 Install Sill Flashing.....	29
Step 13 Sill Flashing Splice.....	30
Step 14 Install Frames.....	31
Step 15 Frame at Entrance.....	32
<b>GLAZING</b>	
Step 16 Glazing Preparation.....	33
Step 17 Installing the Glazing Units.....	34-35
<b>CORNER CONDITIONS</b>	
Step 1 Corner Sill Flashing Fabrication.....	36
Step 2 Corner Sill Flashing Installation.....	37
Step 3 Assemble Frames.....	38
<b>NARROW SIDELITE BASE</b>	
Step 1 Assemble Frames.....	39
<b>INSIDE GLAZE</b>	
Inside Glazing Guidelines.....	40-41



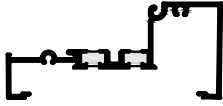
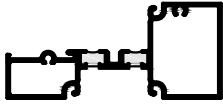

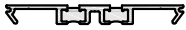

## GENERAL CONSTRUCTION NOTES

1. These instructions cover typical product application, fabrication, installation and standard conditions and are general in nature. They provide useful guidelines, but the final distribution drawings may include additional details specific to this project. Any conflict or discrepancies must be clarified prior to execution.
2. Materials stored at the job site must be kept in a safe place removed from possible damage by other trades. Stack with adequate separation so materials will not rub together, and store off the ground. Cardboard or paper wrapped materials must be kept dry. Check arriving materials for quantity and keep record of where various materials are stored.
3. All field welding must be done in accordance with AISC guidelines. All aluminum and glass should be shielded from field welding to avoid damage from weld splatter. Results will be unsightly and may be structurally unsound. Advise general contractor and other trades accordingly.
4. Coordinate protection of installed work with general contractor and/or other trades.
5. Coordinate sequence of other trades which affect framing installation with the general contractor (e.g. fire proofing, back up walls, partitions, ceiling, mechanical ducts, convectors, etc.).
6. General contractor should furnish and guarantee bench marks, offset lines and opening dimensions. These items should be checked for accuracy before proceeding with erection. Make certain that all adjacent substrate construction is in accordance with the contract documents and/or approved shop drawings. If not, notify the general contractor in writing before proceeding with installation because this could constitute acceptance of adjacent substrate construction by others.
7. Isolate all aluminum to be placed directly in contact with masonry or other incompatible materials with a heavy coat of zinc chromate or bituminous paint.
8. Sealant selection is the responsibility and option of the erector, installer and/or glazing contractor and must be approved by the sealant manufacturer with regard to application and compatibility for its intended use. All sealants must be used in strict accordance with the manufacturer's instructions and applied only by trained personnel to surfaces that have been properly prepared.
9. Sealant must be compatible with all materials with which they have contact, including other sealant surfaces. Consult sealant manufacturer for recommendations relative to shelf life, compatibility, cleaning of substrate, priming, tooling adhesion, etc.
10. Drainage gutters and weep holes must be kept clean at all times. Tubelite cannot accept responsibility for improper drainage as a result of clogged gutters and weep holes.
11. This product requires clearances at head, sill and jambs to allow for thermal expansion and contraction. Refer to final distribution drawings for joint sizes. Joints smaller than 1/4" may be subject to failure. Consult your sealant supplier for proper sizing and joint design.
12. All materials are to be installed plumb, level and true with regard to established bench marks and column center lines established by the general contractor and checked by the erector, installer and/or glazing contractor.
13. Cleaning of exposed aluminum surfaces should be done per AAMA recommendations.
14. Due to varying perimeter conditions and job performance requirements, anchor fasteners are not specified in these instructions. For anchor fastening, refer to the shop drawings or consult the fastener supplier.
15. Check [tubeliteinc.com](http://tubeliteinc.com) for any updates on installation instructions.

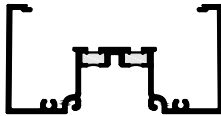

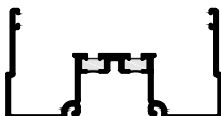

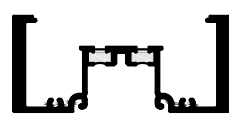
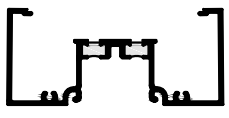
**EXTRUSIONS**

SHAPE	DESCRIPTION	PART No.
	2" x 4 1/2" Open Back Sill	TU24240
	2" x 4 1/2" Intermediate Horizontal	TU24143
	Male Head Receptor	E24339
	Female Head Receptor	E24329
	Deep Closure Pocket (with Plastic Bridge)	A245050
	Closure Pocket (with Plastic Bridge)	A244040
	Thermal Closure Plate	TU24442

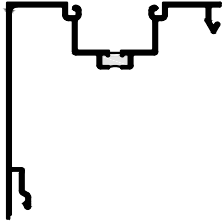
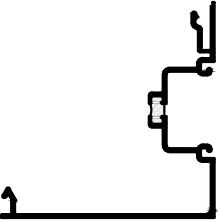

## EXTRUSIONS

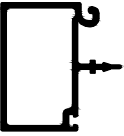
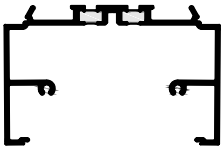
SHAPE	DESCRIPTION	PART No.
	Extruded Sill Flashing	TU24259
	2 1/4" x 4 1/2" Steel Load Vertical	TU24243
	Female Portion of 2 3/4" x 4 1/2" Overall Expansion Mullion	TU24346
	Male Portion of 2 3/4" x 4 1/2" Overall Expansion Vertical Mullion	TU24336
	Head Anchoring Channel	TU24032
	2" x 4 1/2" Heavy Wall Vertical	TU24435
	2" x 4 1/2" Thermal Head/Jamb/Vertical	TU24441
	Glazing Glass Stop	E14104
	High Side Lite Closure	E4TB64











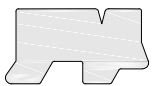
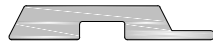

**EXTRUSIONS**

SHAPE	DESCRIPTION	PART No.
	Corner Mullion 4 1/2" x 4 1/2"	T14118
	Corner Mullion 4 1/2" x 4 1/2"	T14119
	Perimeter for Curving (Back)	E14288
	Perimeter for Curving (Face)	E14289
	4 1/2" x 2 1/2" Thermal Sidelite Adapter	TU24047
	Snap-in Adapter For High Sidelite Base	TU24248



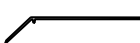
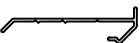

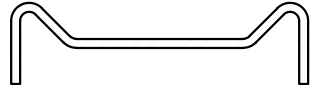



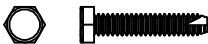

**ACCESSORIES**

SHAPE	DESCRIPTION	PART No.
	Spoke Clip for Curved Head	P288
	Joined Curved Header Vertical	P289

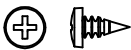
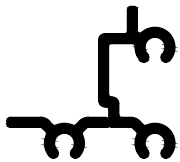
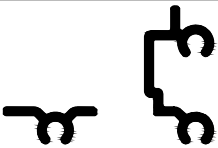
## ACCESSORIES

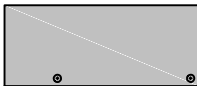
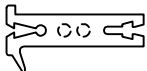
SHAPE	DESCRIPTION	PART No.
	Roll-in Glazing Gasket - 1" Glass	P2728
	Gasket for E14339/TU24329 - Head Receptor	P6296
	Wiper Gasket for TU24336	P1131
	Snap-in Filler	P2474
	Setting Block (Standard)	P1180 (EPDM)
		P1180S (Silicone)
	1/4" Setting Block at Inside Glazed Horizontals	P2413 (EPDM)
		P2413S (Silicone)
	Setting Block at Transom	P4720 (EPDM)
		P4732 (Silicone)
	Flushglaze Gasket for Thin Glass	P2428
	Recessed Frame Gasket for 1 1/8" Glass	P487
	Water Diverter	P1135
	Water Diverter - Curved Head (E14288 & E14289)	P1709
	Pocket Filler	P4563
	Steel Reinforcing 12' - 0" Primed	P1437
	Anti-Walking Block	P1917

ACCESSORIES

SHAPE	DESCRIPTION	PART No.
	#12-24 x 5/8" Phillips Flat Head	S286
	#10 x 1/2" Type B Phillips Truss Head	S191
	#10-24 x 1 Hex IND Type F Screw	S449
	#10 x 1 3/4" Type B Phillips Pan Head	S009
	#8 x 3/8" Type A Phillips Pan Head	S196
	Frame Clip (Unmodified)	P2434
	Frame Clip (Modified)	P2434
	Frame Clip	P2433
	End Dam for TU24259	P2455
	Clip	P1707
	3" Long Weep Baffle - Optional at weeps on TU24259	PTB42
	Silicone Splice Sleeve Sill Flashing	P3444
	Rigid PVC pocket filler - 120" lengths	P4543



## QUICK REFERENCE CHECKLIST

1. Make sure the opening is square and the caulk joints are 1/4" minimum around the frame. Note: Frames that utilize the TU24259 sill flashing must have a minimum of 3/8" caulk joint at head.
2. Ensure surfaces that will be sealed are free of contaminants that can lead to adhesion issues.
3. Sill flashing must be properly shimmed and level from left to right and front to back for proper drainage.
4. A continuous line of sealant must be applied between the sill and the top interior leg of the sill flashing.
5. Check that all weeps and baffles (if required) conform to the locations and sizes called out in these instructions.
6. Ensure that sill flashing weep holes are not plugged by the perimeter seal.
7. A sill flashing splice is needed in openings larger than 24 feet. Follow instructions for installing and sealing.
8. End dams must be installed and sealed onto the sill flashing. Fasteners used must also be sealed.
9. Where the sill flashing abuts a door jamb, the jamb pocket cavity must be completely sealed to dam this area.
10. Cap seal any exposed anchor or screw.
11. Butter seal ends of horizontal frame members that are joined to vertical members.
12. Water diverter installation and sealing is critical. Check installation against instructions to ensure conformity.
13. Apply sealant between all corner gasket joints.
14. Glass bites must be equal on all sides.
15. Double check anchor size and location against installation instructions or approved shop drawings.
16. Insure that interior seal is married to sill flashing interior leg.

## TYPICAL ELEVATION DEATILS

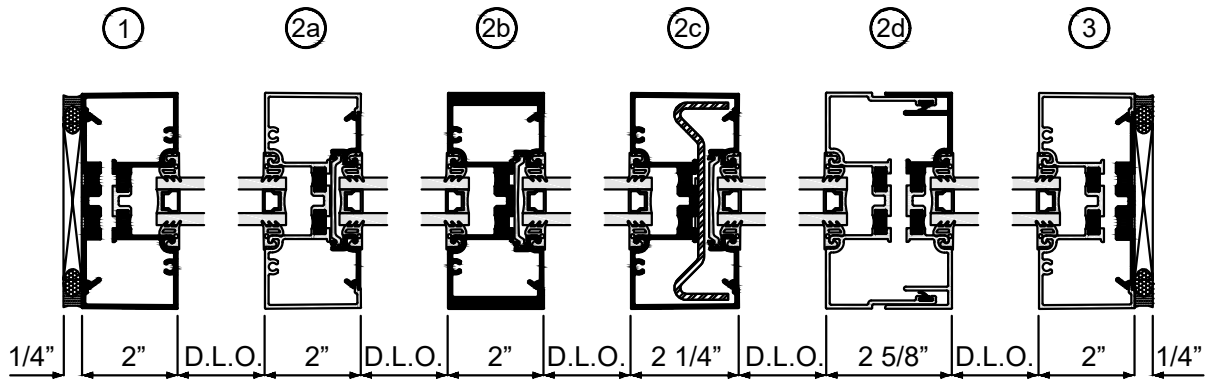
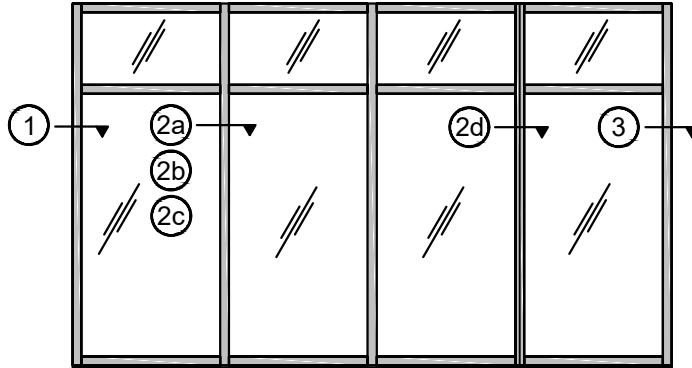

## TYPICAL ELEVATION DEATILS

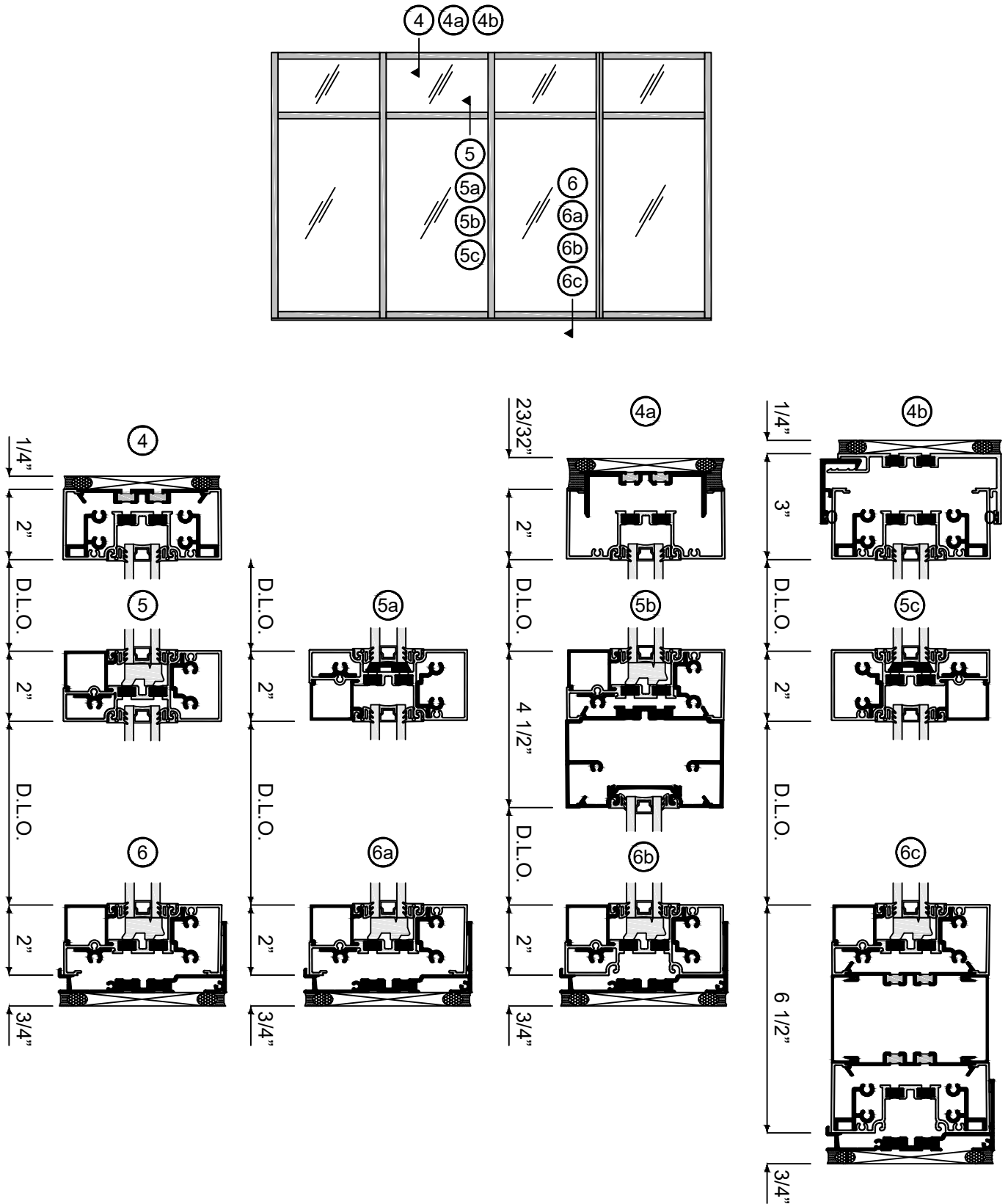

## DOOR FRAME ELEVATION DEATILS

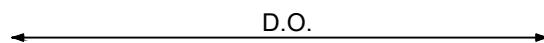
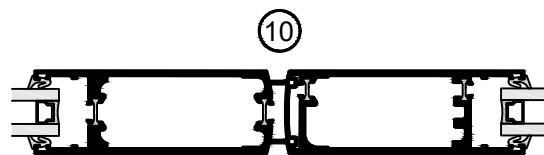
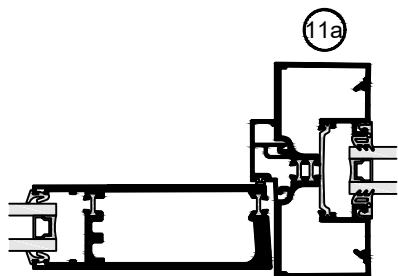
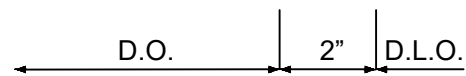
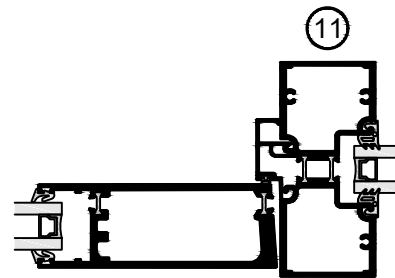
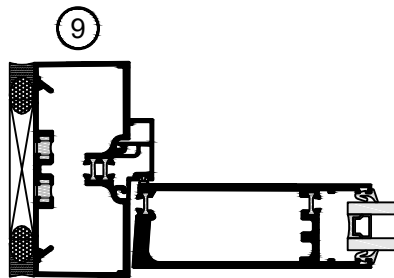
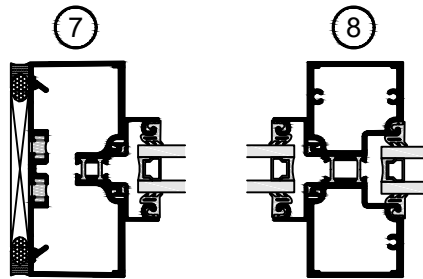
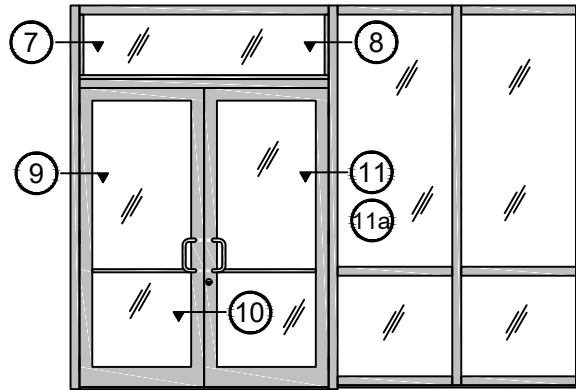

## DOOR FRAME ELEVATION DEATILS

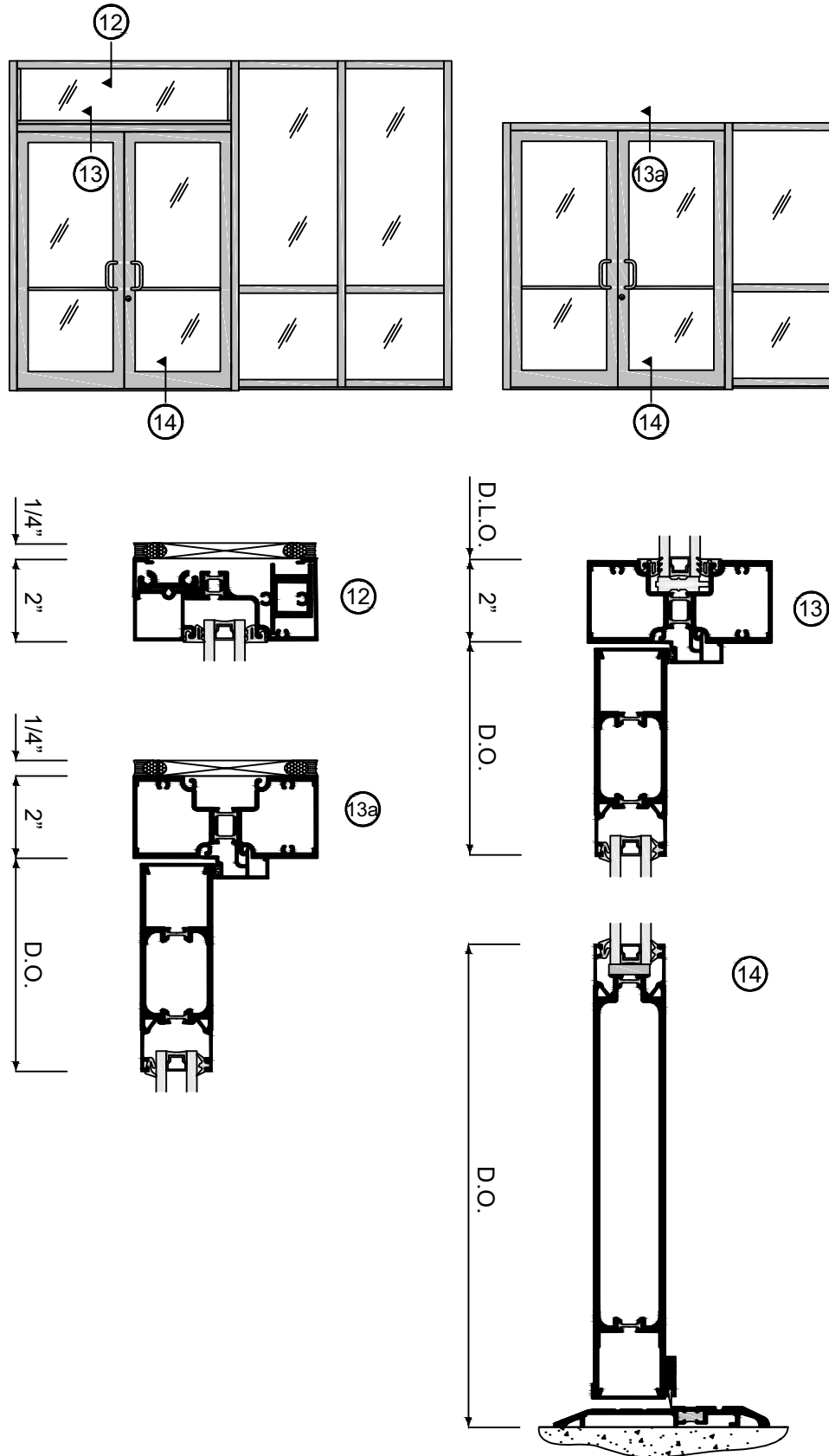

## FRAME FABRICATION

### Step 1: Determine Frame Size

#### Determine Frame Width

- A. Check that the opening is square and plumb at both ends. Units must be installed in a true rectangle.

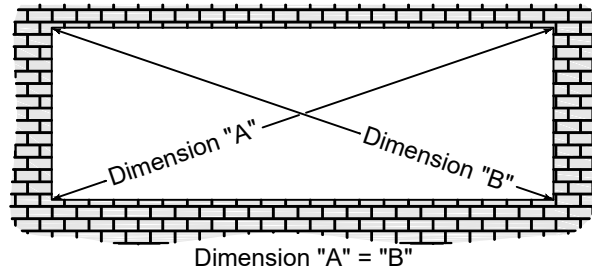

Fig. 14.1

- B. Measure the width of the masonry opening at the top, middle and bottom.
- C. Select the smallest dimension measured. To determine the frame width to be used, subtract a minimum of 1/2" from the smallest measured width, to allow a minimum of 1/4" at each jamb for shimming and caulking.
- D. Allow a larger clearance if necessary to accommodate building tolerances, an out-of-square opening, anticipated thermal expansion within the unit and/or as required by project.
- E. Expansion mullions must be used every 16' to 20'.

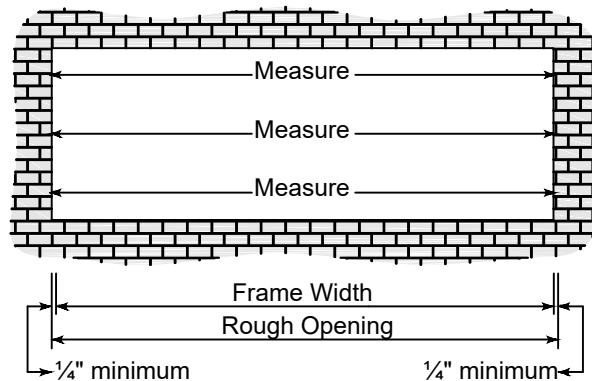

Fig. 14.2

#### Determine Frame Height

- A. Measure the height of the opening in several places along the entire length of the opening.
- B. To determine the frame height to be used, select the smallest dimension measured and subtract 1 1/4" to allow a minimum of 3/4" at sill and 1/2" head for shimming and caulking.
- C. Allow a larger clearance if necessary to accommodate building tolerances, an out-of-square opening, anticipated thermal expansion within the unit and/or as required by project.

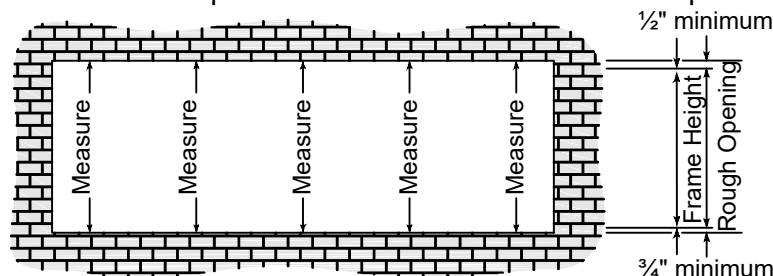

Fig. 14.3

## FRAME FABRICATION

### Step 2: Cut Material to Size

Note: Door framing material comes cut to size from the factory. In cases of door frames with transoms, the door jambs must be cut down in the field to size and head member attached per standard instructions shown within this manual.

#### Framing Members

Sill Flashing with Entrance....	Door Jamb to End of Frame + $\frac{1}{8}$ " (SEE Fig. 15.1)
Sill Flashing without Entrance.....	Frame Width + $\frac{1}{4}$ "
Verticals.....	See Fig. 20.4
Head Receptor.....	Frame Width + $\frac{1}{4}$ "
Head Receptor Snap Stop.....	Frame Width + $\frac{1}{4}$ "
Head, Horizontal & Sill.....	D.L.O.
Horizontal & Sill Glass Stops.....	D.L.O. - $\frac{1}{32}$ "
Closure Pockets at Verticals.....	See Fig. 20.4
Glazing Adaptors.....	D.L.O. - $\frac{1}{32}$ "
Snap-In Fillers.....	Refer to Approved Shop Drawings

#### Accessories

Exterior Gasket.....	D.L.O. + Allowance*
Interior Gasket.....	D.L.O. + Allowance*

\*Allowance =  $\frac{1}{8}$ " extra length per foot of D.L.O.

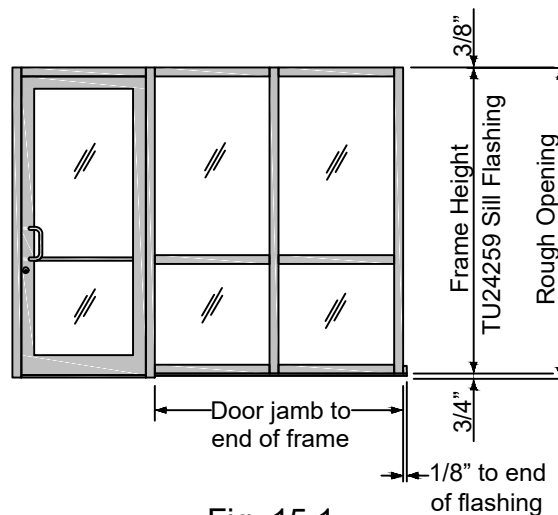

**Fig. 15.1**

#### Sill Flashing Note:

For openings wider than 24', the sill flashing must be spliced at the center line of a D.L.O. every twelve to fifteen feet. Splice joint should be  $\frac{3}{8}$ " wide. SEE Step 13, Page 30 for sill flashing splice details.

## FRAME FABRICATION

### Step 3: Fabricate Sill Flashing

A. When using TU24259, drill two 7/32" dia. weep holes at 2" and 6" from each side of the verticals.

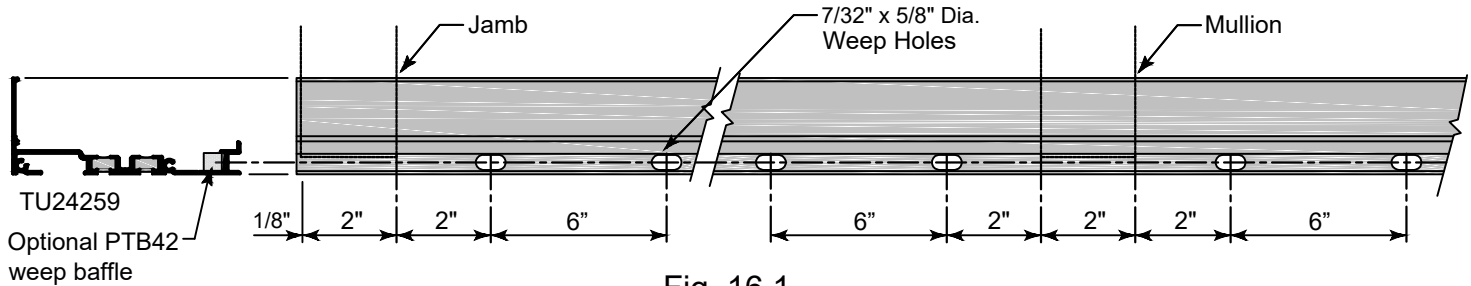
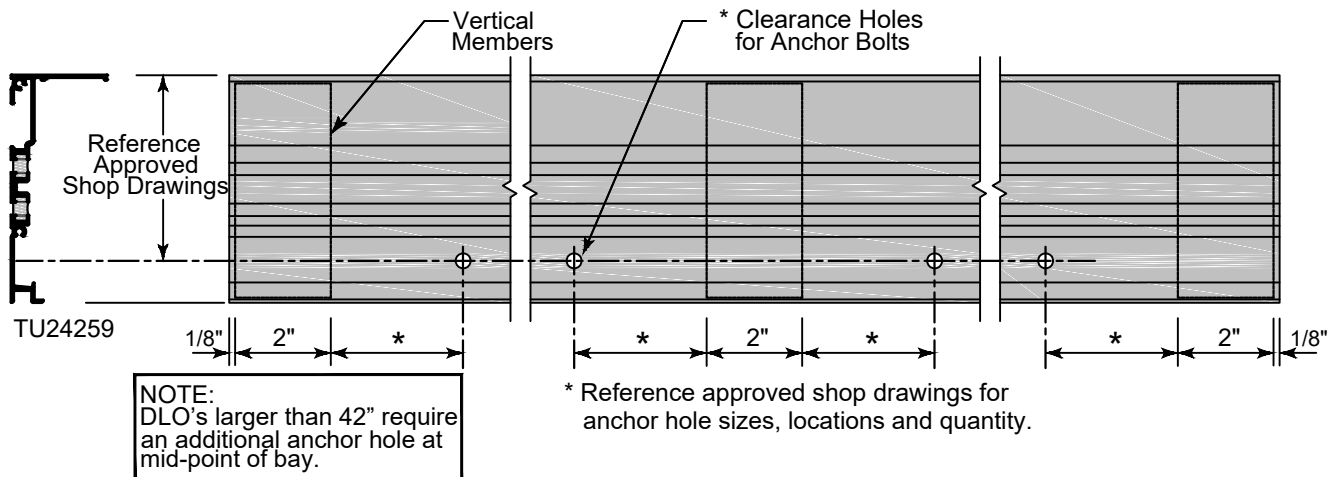

Fig. 16.1

B. Drill clearance holes for perimeter anchors. Size and quantity vary per job. Refer to approved shop drawings. Note: If head receptors are used, follow the same procedure as on the sill flashing.



**NOTE:**  
DLO's larger than 42" require an additional anchor hole at mid-point of bay.

\* Reference approved shop drawings for anchor hole sizes, locations and quantity.

Fig. 16.2

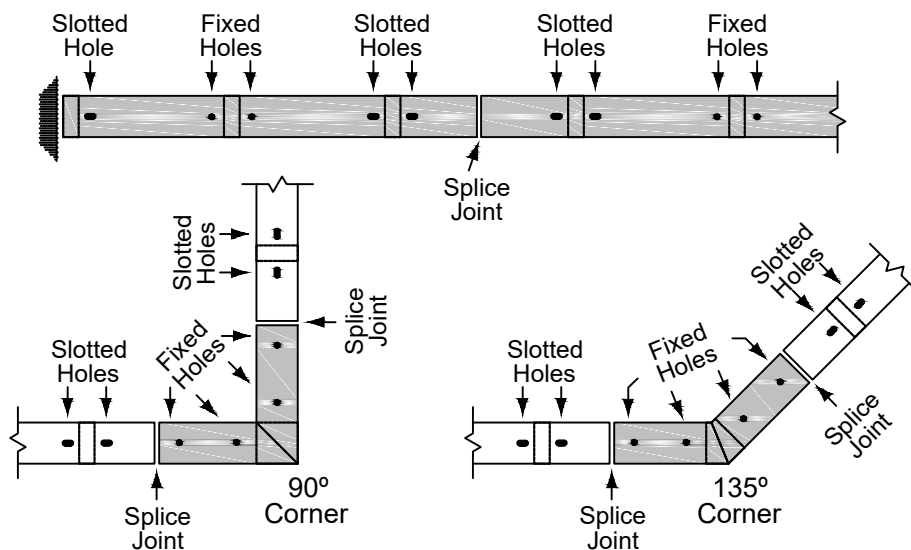

Typical Sill Flashing Anchor Hole Patterns (Head receptor similar)  
(Refer to approved shop drawings for project requirements)

Fig. 16.3



## FRAME FABRICATION

### Step 4: Fabricate Verticals & Closure Pockets for Horizontals

- A. Drill frame assembly holes in verticals, jambs & closure pockets with drill fixture P1139. See Figure 12.1 & Figure 17.1.
- A.a. For screw spline assembly, use holes marked 'X' in P1139. See Figure 17.2.
- A.b. For shear block assembly, use holes marked 'Z' in P1139. See Figure 17.2.

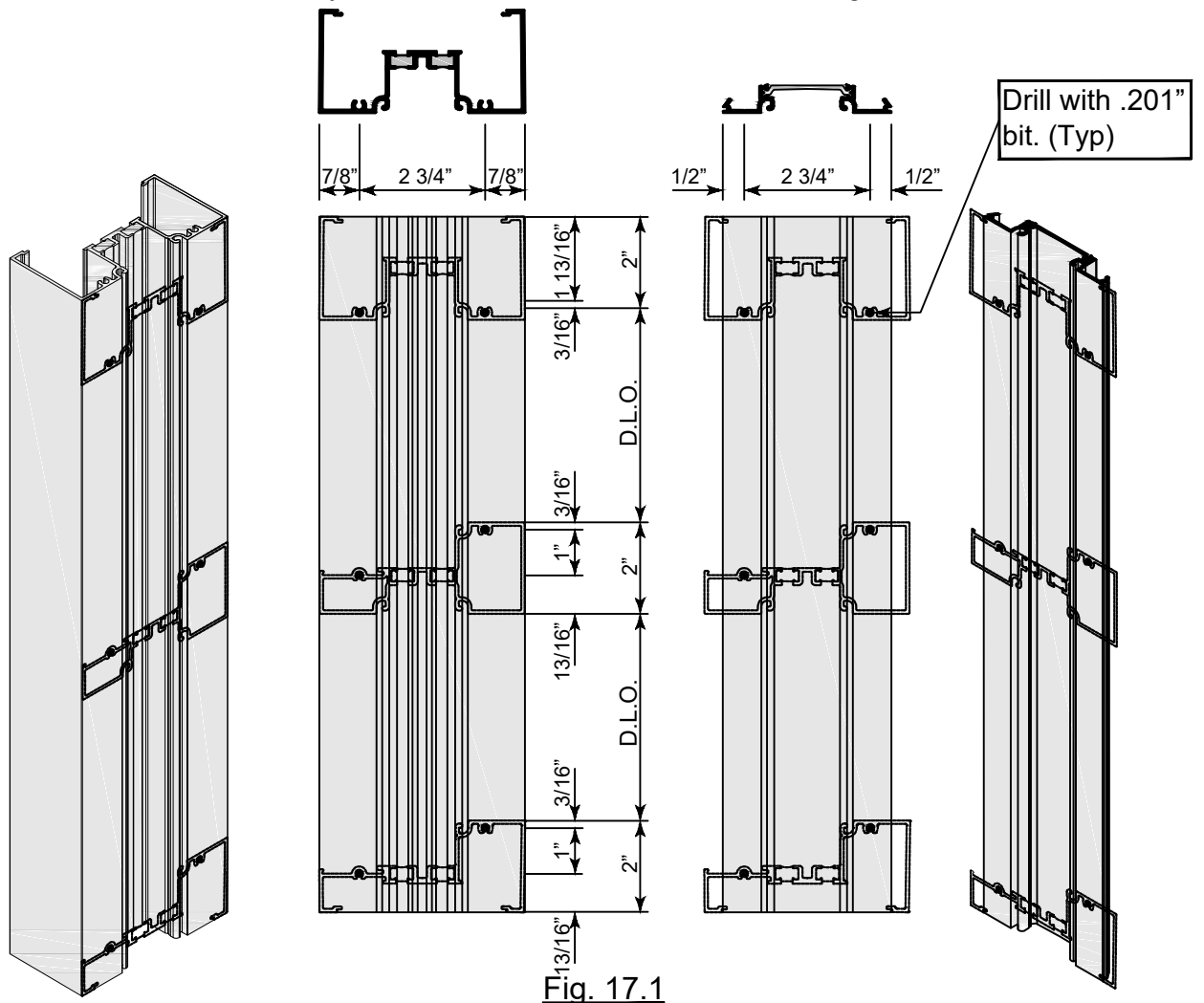
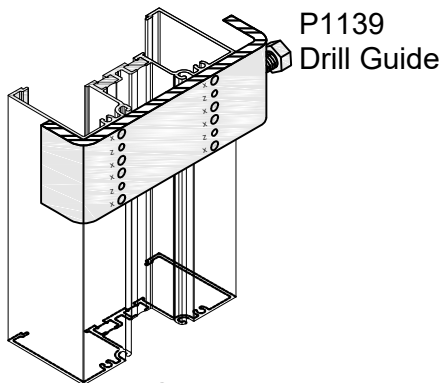
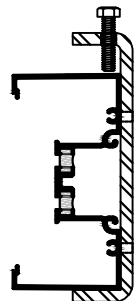

Fig. 17.1



P1139  
Drill Guide



Open Back  
Mullion

Lightly tighten bolt  
to hold drill guide in  
place while drilling

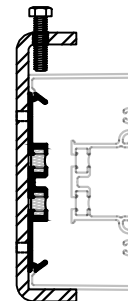

Snap-in  
Filler

P1139  
Drill Guide

Use short drop-off piece  
of Open Back Mullion to  
facilitate drilling Snap-in  
Filler.

Guide holes are marked  
with 'X' and 'Z' for required  
hole patterns.

**FRAME FABRICATION**

**Step 5: Fabricate Horizontal Members for Shear Blocks**

- A. For shear block assembly, drill .201" dia. holes in the head, horizontal and sill members as shown in Figure 18.1 & Figure 18.2. Holes in head are to be drilled and countersunk from screws.

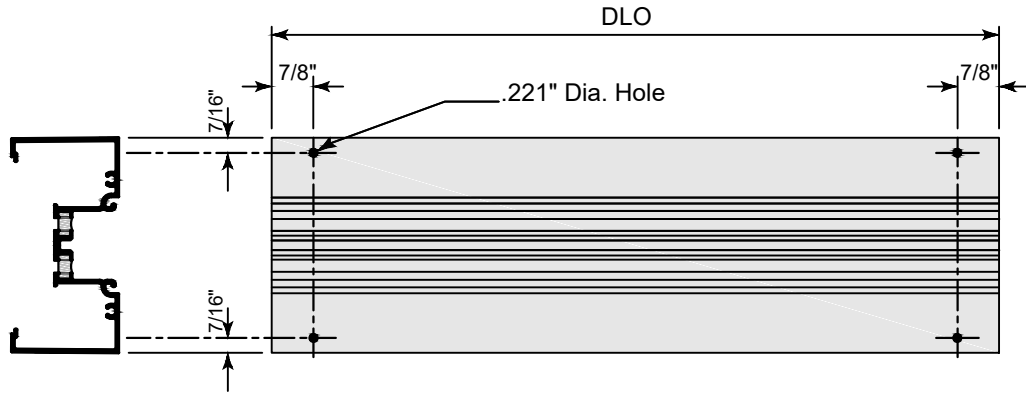

**Fig. 18.1**  
Head

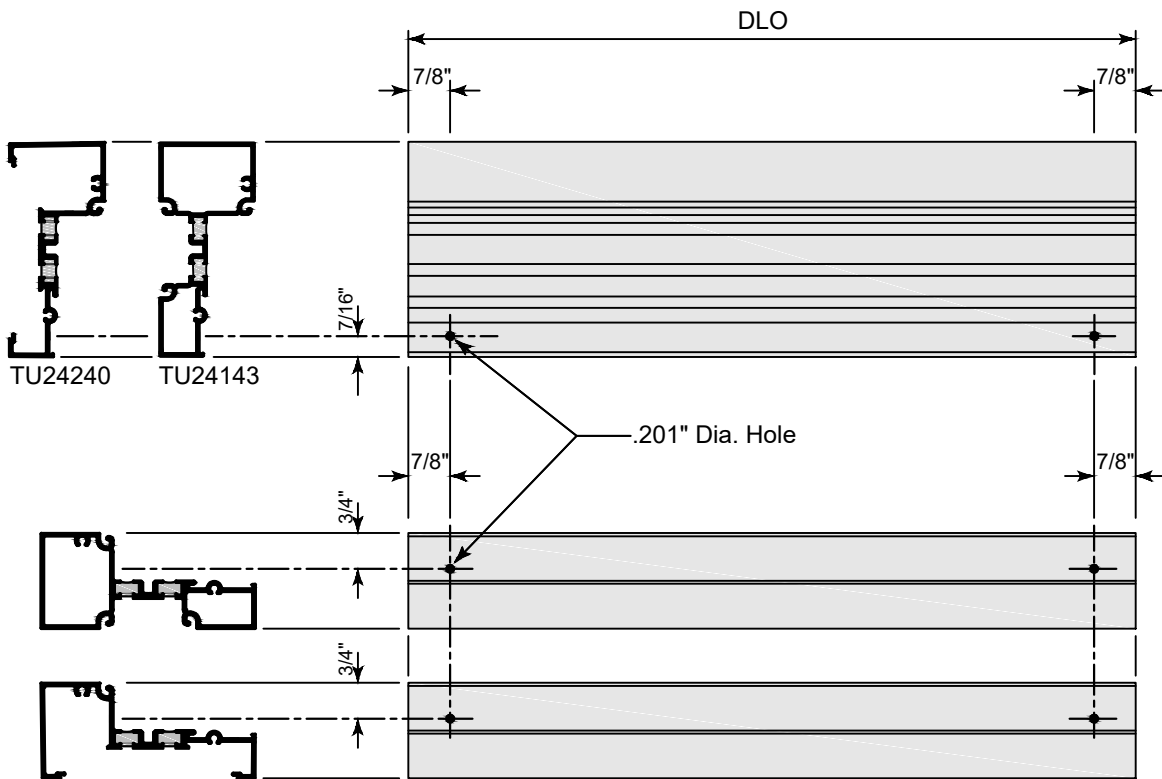

**Fig. 18.2**  
Horizontal & Sill

## FRAME FABRICATION

### Step 6: Fabricate Shear Blocks (As Required)

- A. For shear block assembly, P2434 shear block must be modified.
- B. See Figure 19.1 for instructions on modifying for the various horizontal sections.

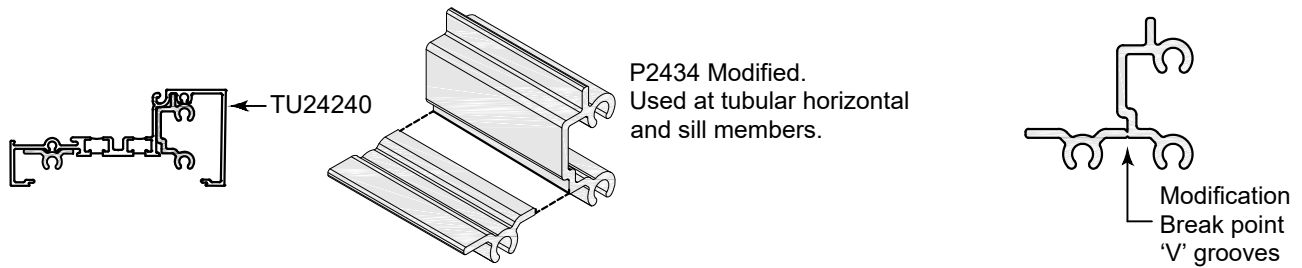
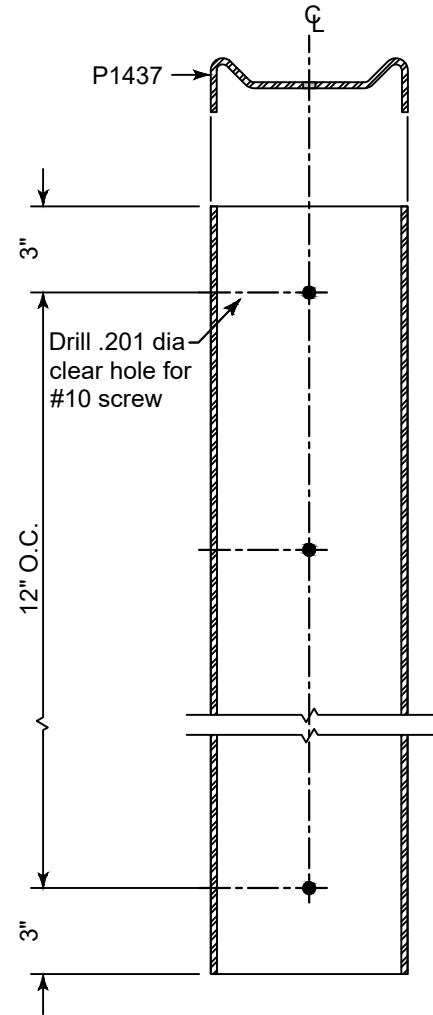

Fig. 19.1

**FRAME FABRICATION**

**Step 7: Steel Stiffener (As Required)**

- A. If P1437 steel stiffeners are required (refer to approved shop drawings), cut 4" shorter than the vertical mullion length. Paint ends to prevent rust.
- B. Use thermal insulator tape or shim (not by Tubelite) to isolate the steel reinforcement from the vertical members (thermal applications only).
- C. Drill and countersink clear hole in vertical and pad hole in P1437 steel stiffener for attachment screw. Size and spacing of screw per approved shop drawings.



**NOTE:**  
Use of #10 screw at spacing shown as a general guide. Refer to approved shop drawings or engineer's calculations for specific application.

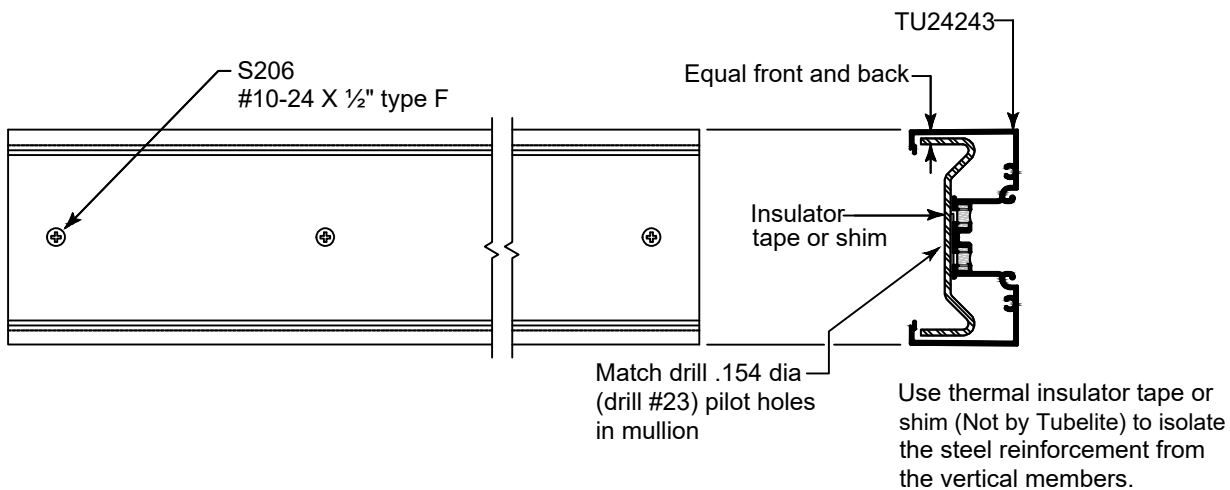

**Fig. 20.1**

**NOTE:** A244040 strutted pocket closure must be used when applying P1437 steel reinforcement.

## FRAME ASSEMBLY

### Step 8: Install Sill Flashing End Dams

- A. Install P2455 end dam at each end of sill flashing with (2) S196 #8 x 3/8" PH screws. Set aside and allow sealant to cure.
- B. Align P2474 PVC thermal baffle with sill flashing anchor bolts and drill holes to allow clearance for anchor bolt heads.

NOTE: If sill flashing is spliced, install end dams on jamb-end only. Refer to Step 13, Page 30 for splicing instructions.

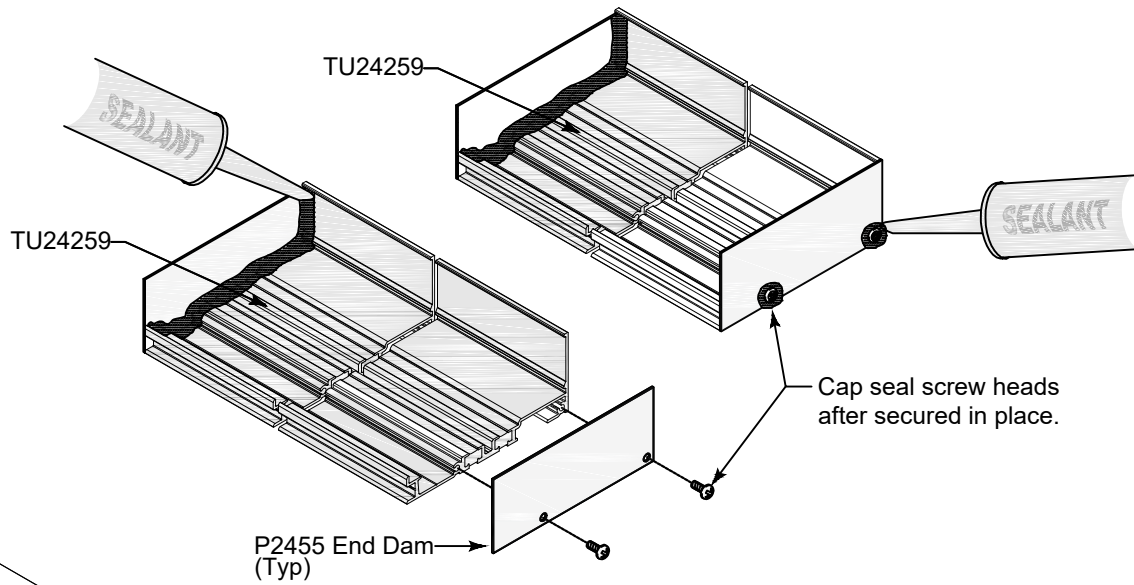

Fig. 21.1

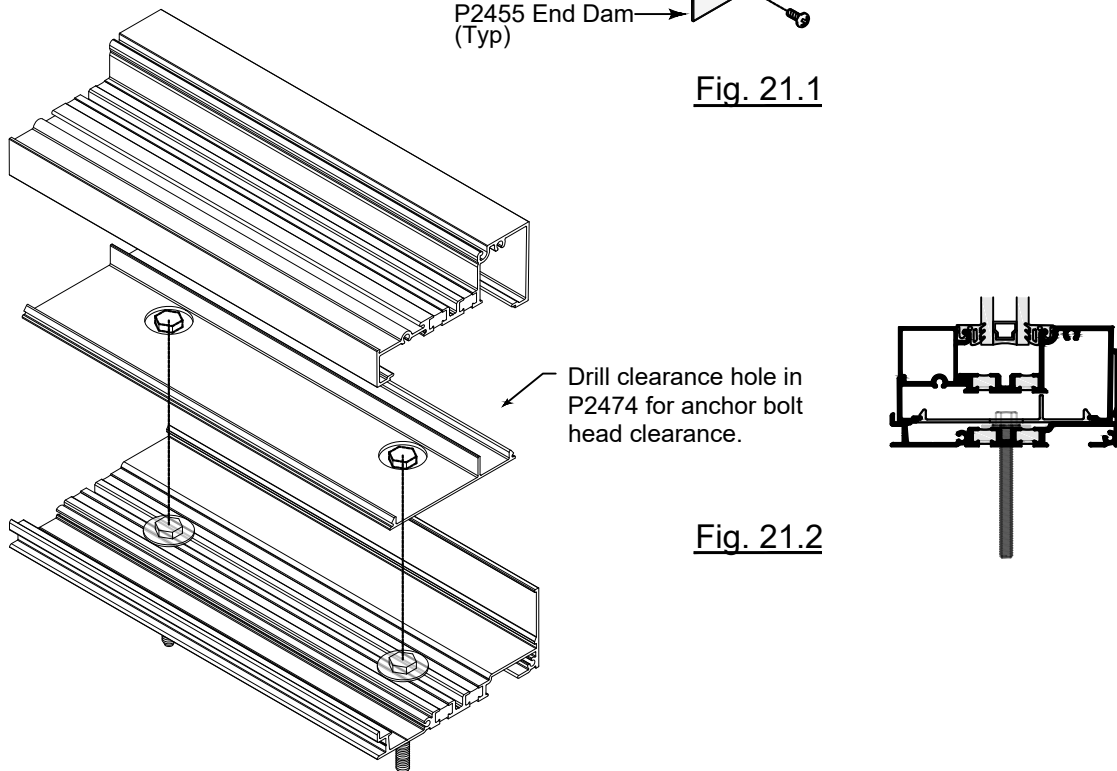

Fig. 21.2

## FRAME ASSEMBLY

### Step 9: Optional High Sidelite Bases

Prior to assembling frames, follow these steps if using high sidelite base members.

- A. Pre-attach P4563 pocket filler into the pocket of the vertical mullion and closure pocket members. Cut length of the filler can be determined by measuring from the bottom of the vertical mullion/closure pocket to the underside of the water diverter at the high sidelite base. See Figure 22.1.
- B. Attach snap-in adaptor TU24248 to the TU24243 horizontal (lower member of the sidelite base). See Figure 22.2.
- C. Seal joints between the adaptor and horizontal.
- D. Attach snap-in adaptor TU24248 to the TU24240 open back sill (upper member of the sidelite base). See Figure 22.2.

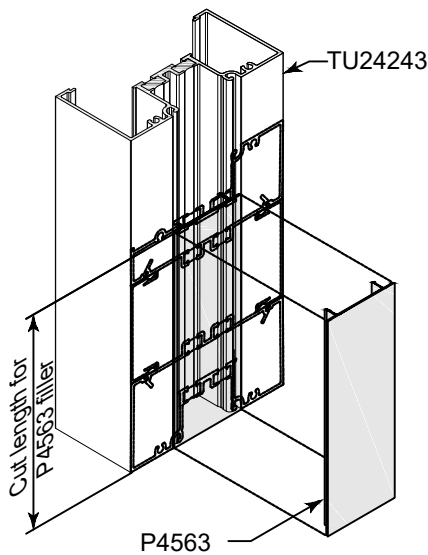

**Fig. 22.1**

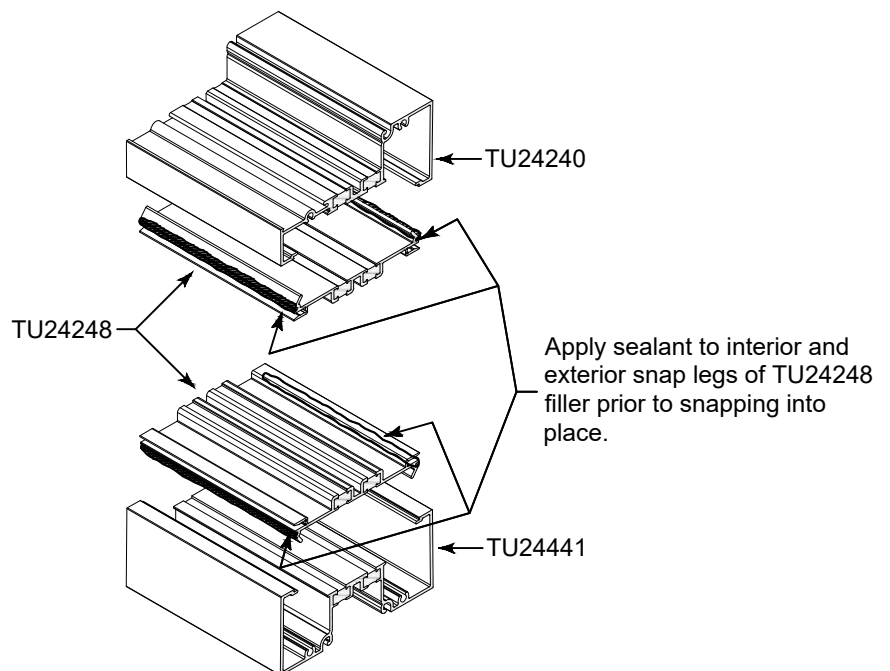

**Fig. 22.2**

## FRAME ASSEMBLY

### Step 9: Optional High Sidelite Bases (Continued)

- E. Seal ends of the upper and lower members where it will contact the vertical mullion and closure pocket. See Figure 23.1 & Figure 23.2.
- F. Before attaching the upper and lower members to the vertical, determine the height of the snap cover to be used. Attach the lower and upper members of the sidelite base to the vertical and closure pocket.
- G. Optional: Place one-sided closed cell adhesive tape along the edges of the vertical where the sidelite base covers will be installed. Place a bead of sealant onto the tape. See Figure 23.3.
- H. Place a bead of sealant into the receptor areas of the snap-in adaptor. See Figure 23.3.

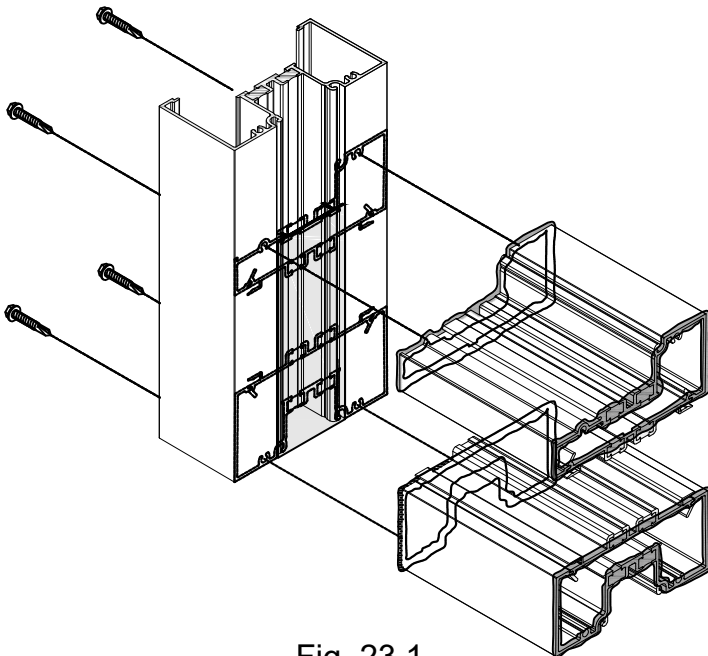

Fig. 23.1

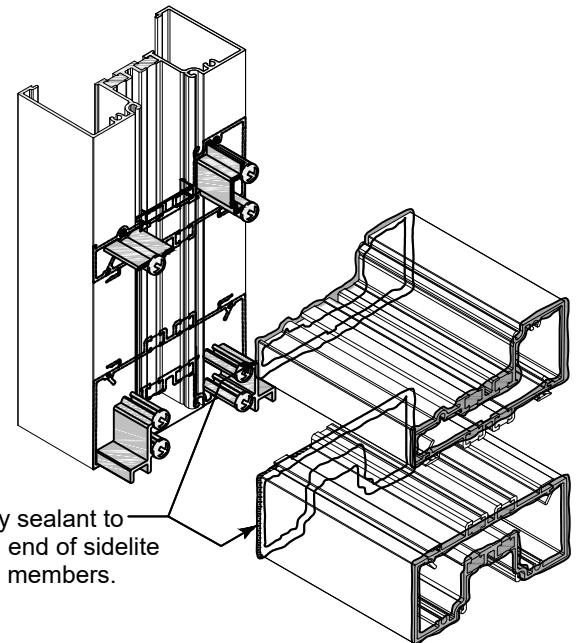
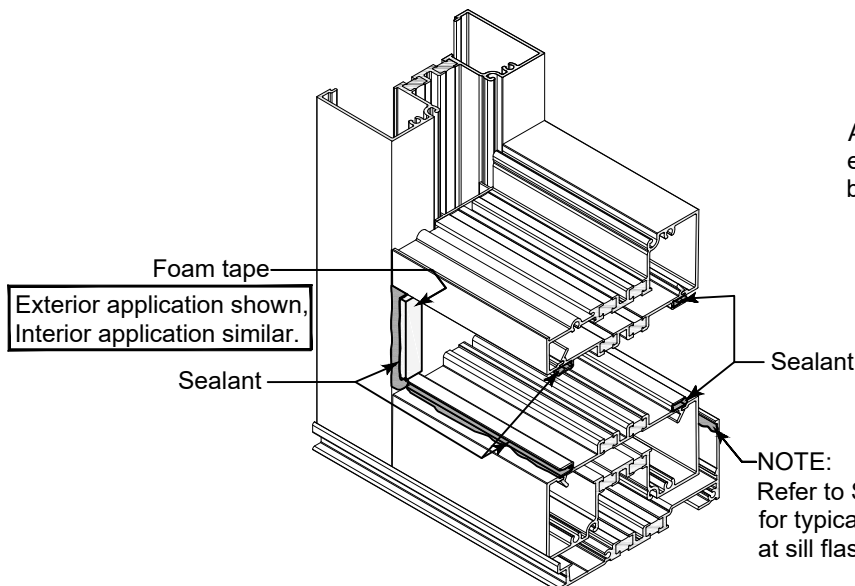

Fig. 23.2



NOTE:  
Refer to Step 11, page 28  
for typical seals required  
at sill flashing.

Fig. 23.3

**FRAME ASSEMBLY**

**Step 9: Optional High Sidelite Bases (Continued)**

- I. Attach a snap cover or brake metal to the inside surface of the sidelite base. See Figure 24.1.
- J. J. From the exterior, seal joints between the snap cover and vertical members. See Figure 24.2.
- K. K. Attach a snap cover or brake metal to the exterior. See Figure 24.1.

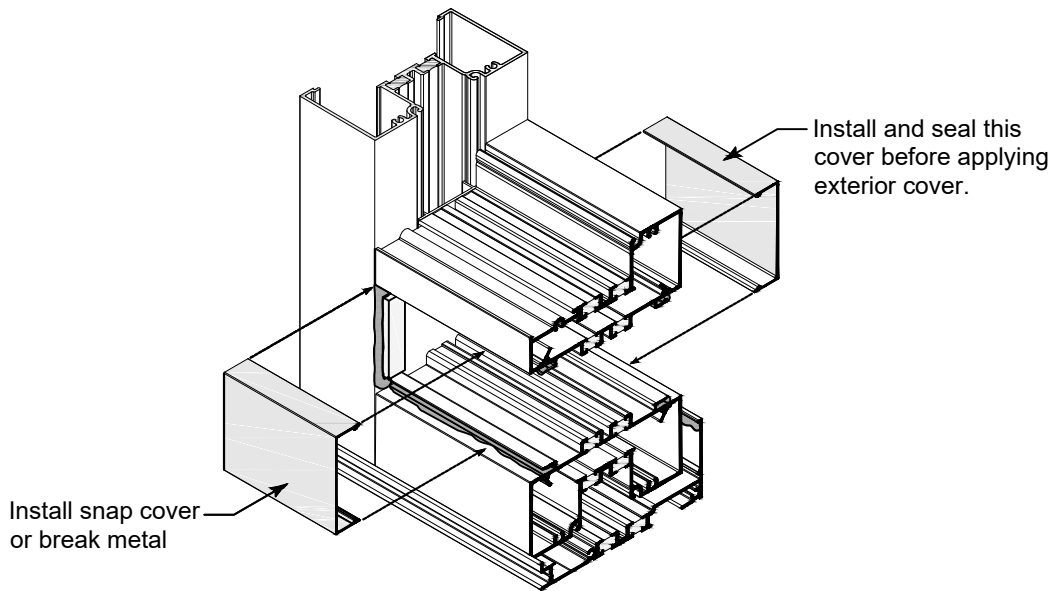

**Fig. 24.1**

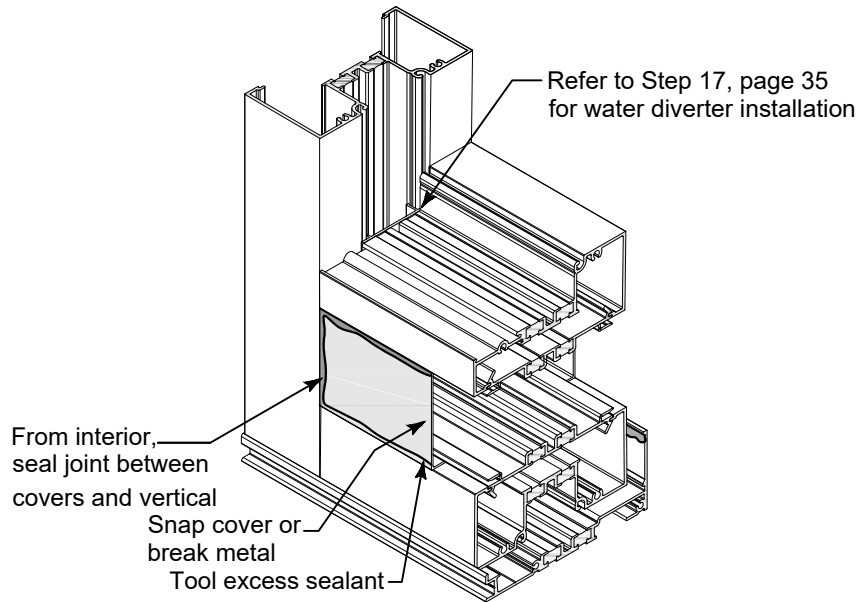

**Fig. 24.2**



## FRAME ASSEMBLY

### Step 10: Assemble Frames

#### Screw Spline Assembly

- A. Clean all mating surfaces on horizontal & vertical.
- B. Apply sealant to ends of the head, horizontal and sill members prior to attaching to the vertical members. See Figure 25.1.
- C. Attach head, horizontal and sill members to the vertical and closure pocket members with #10-24 x 1 Hex IND Type F frame assembly screw.
- D. Tool sealant at each joint.

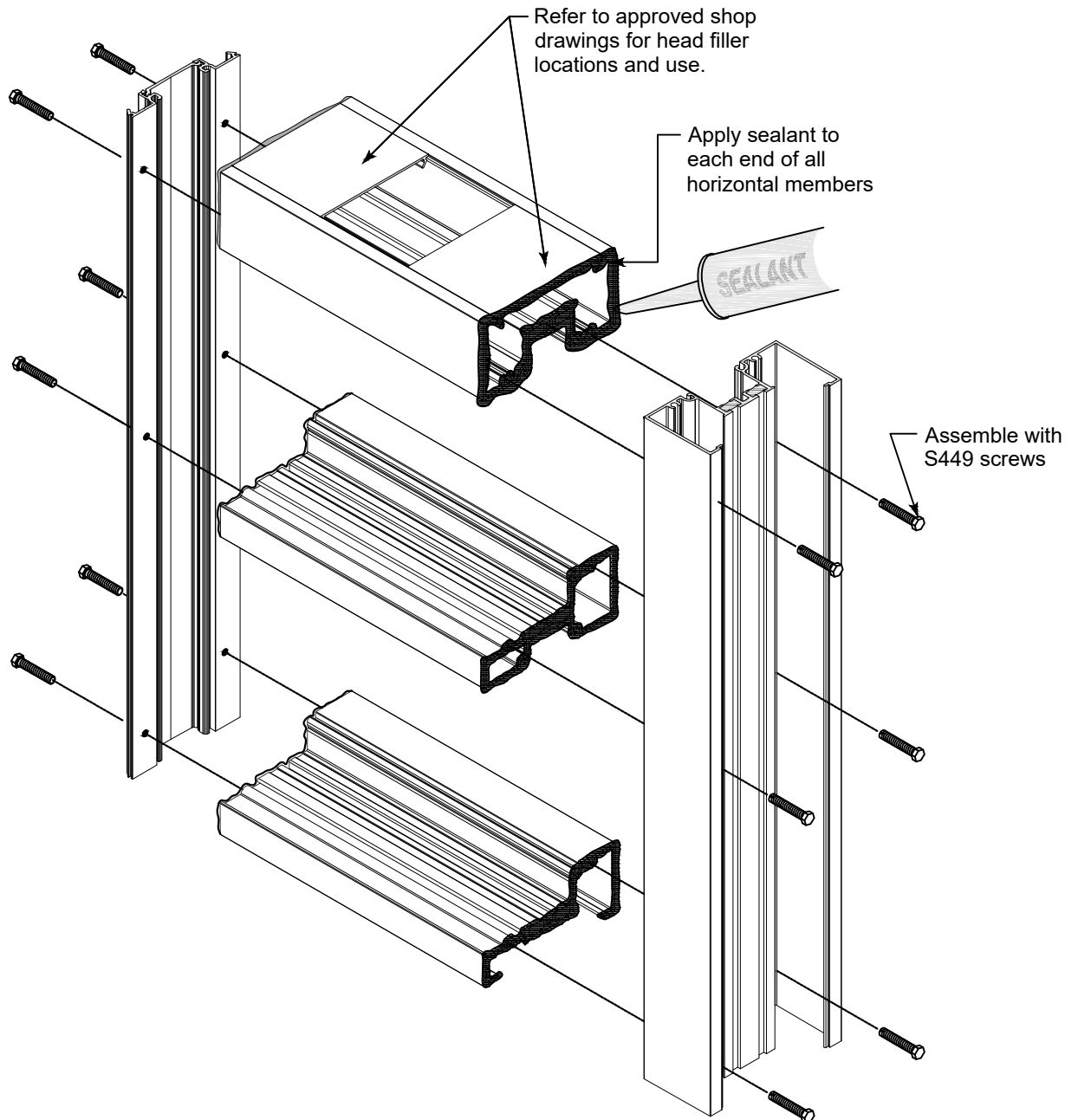

Fig. 25.1

## FRAME ASSEMBLY

### Step 10: Assemble Frames (Continued)

#### Shear Block Assembly

- Install shear blocks onto vertical and closure pocket members with S009 #10 x 1 3/4" PH screw as shown in Figure 26.1.
- Clean all mating surfaces on horizontal, vertical and shear block.
- Apply sealant to ends of the head, horizontal and sill members and to perimeter of shear blocks prior to attaching the horizontal members to the vertical members. See Figure 26.2.
- Install head, horizontal and sill members over the shear blocks.
- Match drill tap hole in head shear block with drill #14 (.182 dia) for #12 screw.
- Match drill tap hole in horizontal and sill shear blocks with drill #23 (.154 dia) for #10 screw.

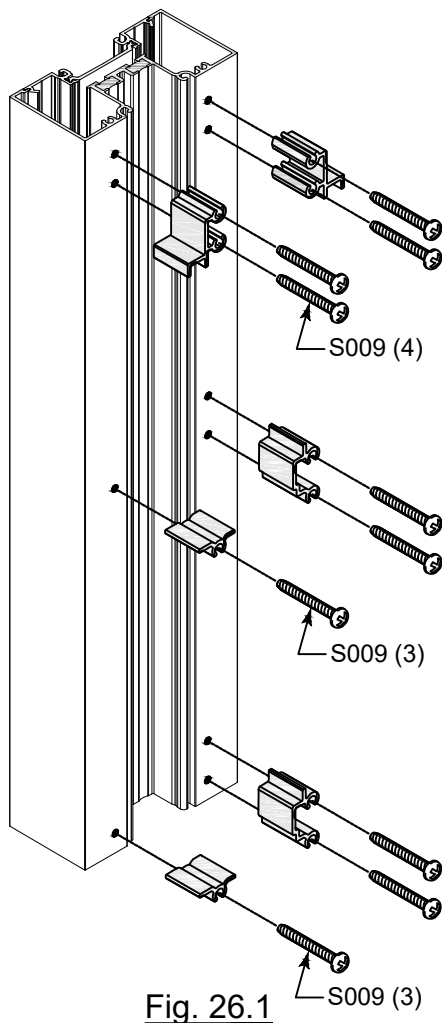

Fig. 26.1

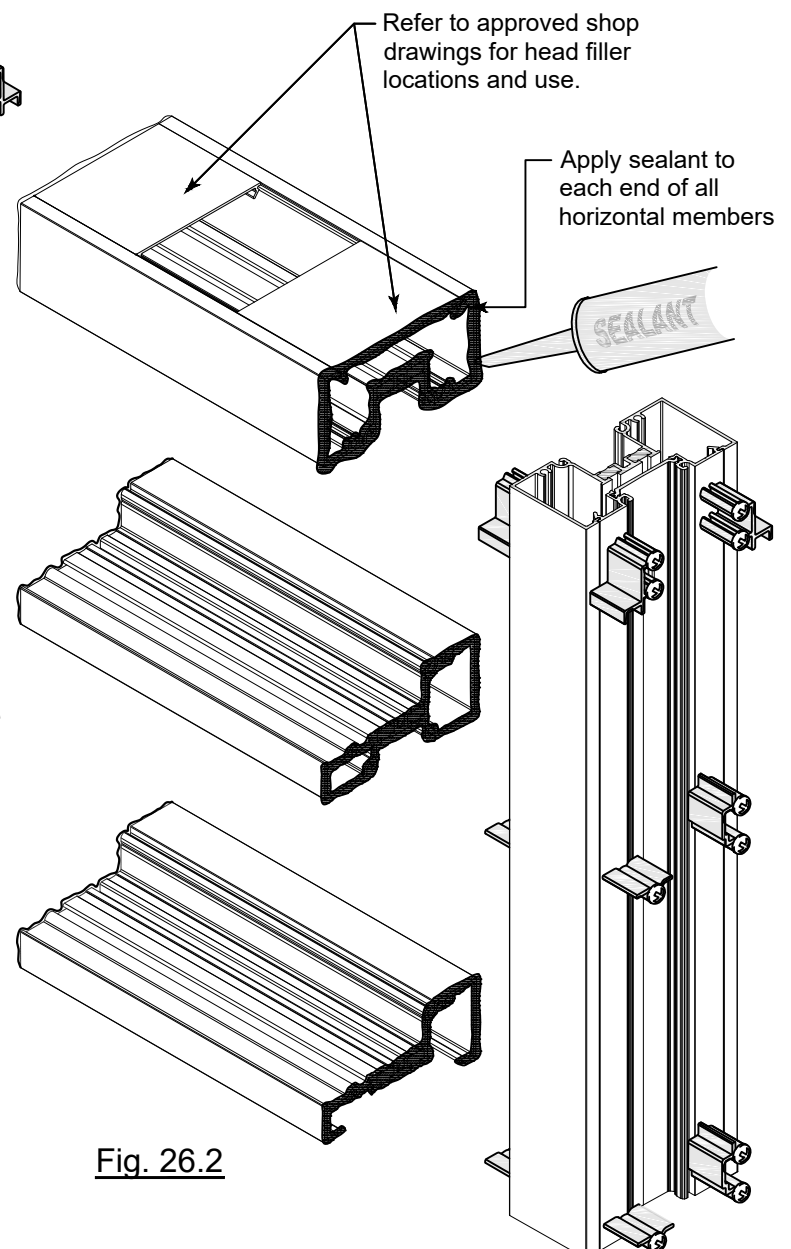

Fig. 26.2

## FRAME ASSEMBLY

### Step 10: Assemble Frames (Continued)

#### Shear Block Assembly (Continued)

- G. Secure head member to shear block with (1) S149 #12 x 3/4" FH screw. Secure horizontal and sill members with (2) S191 #10 x 1/2" truss head screw. See Figure 27.1.
- H. Cap seal heads of screws at horizontal and sill members.

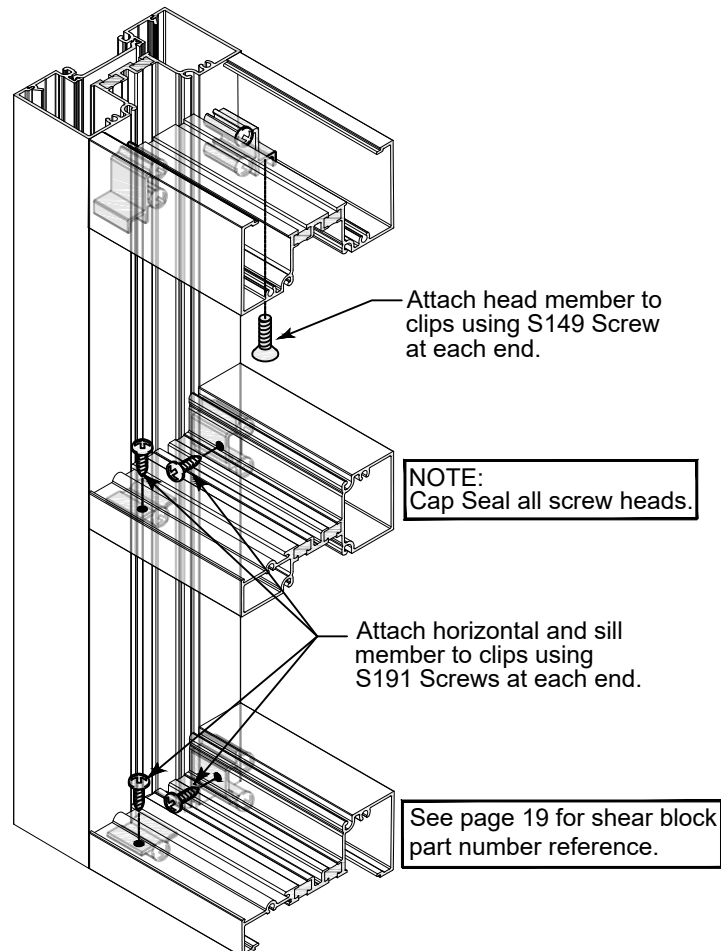

Fig. 27.1

**FRAME FABRICATION**

**Step 11: Install Gaskets**

- A. Install glazing gasket on one side of the framing member, depending upon direction of glazing.
  - a. For inside glazing, install gaskets on exterior side of framing first.
  - b. For outside glazing, install gaskets on interior side of framing first.

**DO NOT STRETCH GASKETS WHEN INSTALLING.** Start at center of D.L.O. and work towards the ends.

**NOTE:** Allowance = 1/8" extra length per foot of D.L.O.

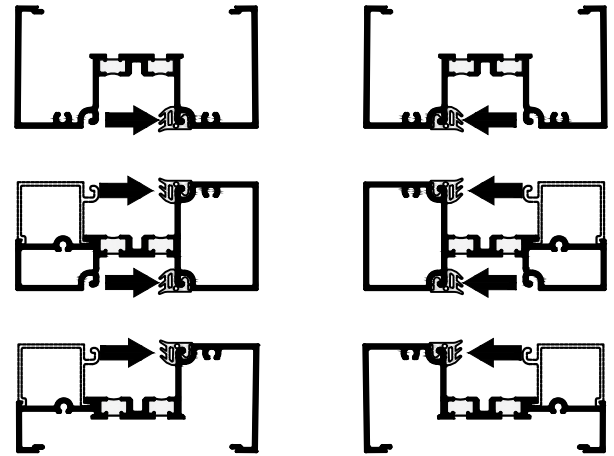

OUTSIDE GLAZE

INSIDE GLAZE

**IMPORTANT NOTE:** Clean ends of the gaskets with IPA prior to sealing the corners.

Fig. 28.1

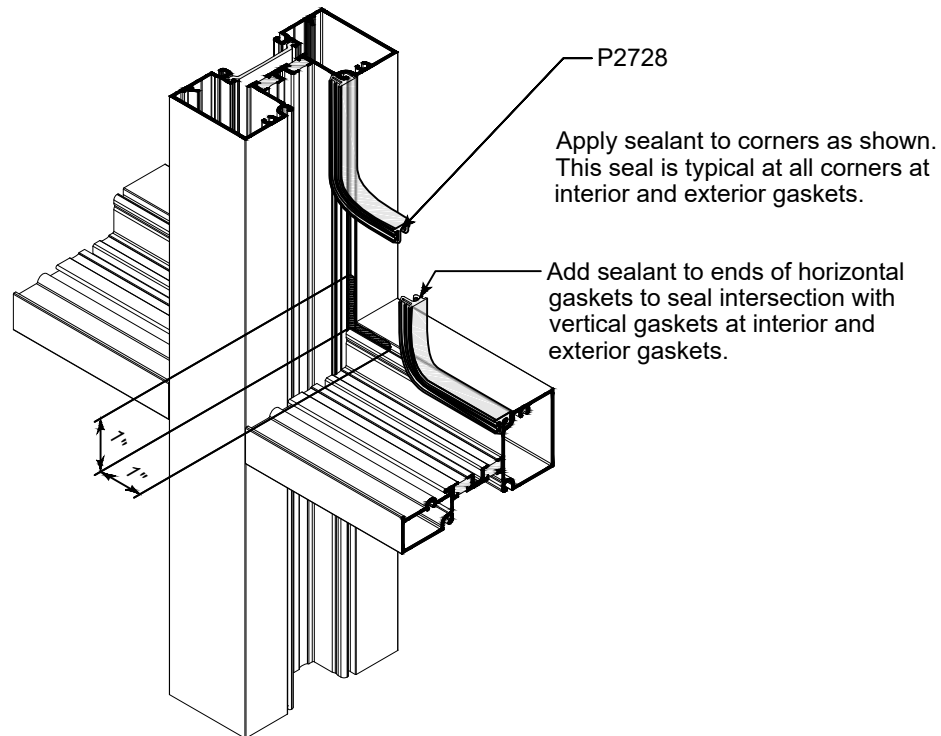

Fig. 28.2

## FRAME INSTALLATION

### Step 12: Install Sill Flashing (if required)

- A. Center the sill flashing in the opening. If sill flashing is spliced, be sure the joint at the jamb is per approved shop drawings (jamb caulk joint minus 1/8"). If there is an entrance door in the opening, leave a gap in the sill flashing for the door frame to be installed and refer to Step 15, page 32 for sealing instructions. Splice joint to be 3/8" minimum.
- B. At the highest point of the sill (smallest rough opening height), shim the sill flashing with a minimum 1/4" shim space. Sill flashing must be installed level side to side and front to back.
- C. Shim tight between the sill flashing end dam and building condition to ensure end dam is not dislodged during frame installation. Remove shim after frames are set in place.
- D. Anchor sill flashing to building substrate per approved shop drawings. Cap seal anchors after installation. Where the sill flashing abuts a door jamb, the sill flashing anchor must be located within 6" of the door jamb.

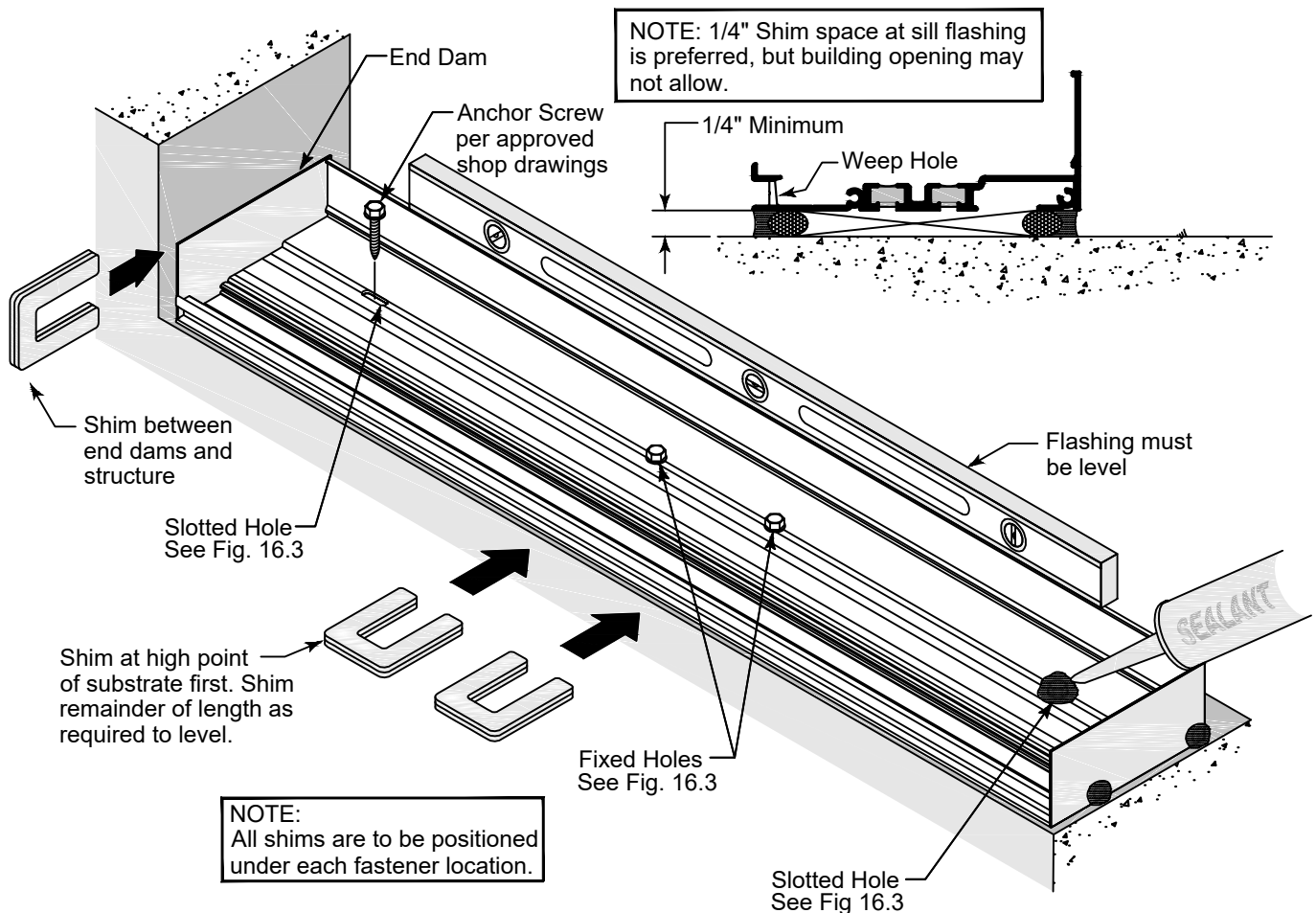

Fig. 29.1

## FRAME INSTALLATION

### Step 13: Sill Flashing Splice

#### Silicone Splice - Figure 30.1.

- A. Continue installing sill flashing per Step 12 across the opening.
- B. Lay P3444 silicone sheet into sill flashing at splice location (center of D.L.O.) and cut to length.
- C. Install backer rod under the sill flashing at the splice joint.
- D. Clean surfaces where splice will be applied. Apply sealant as shown in Figure 30.1.
- E. Set silicone splice sleeve in place and tool sealant. Seal front and back joints.
- F. Do not locate a splice directly below a vertical mullion. Center line of D.L.O. is preferred.

Allowing for contours  
cut splice material to  
length

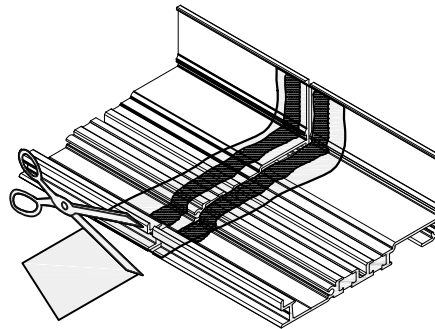

Press splice into  
silicone sealant  
conforming to  
flashing shape

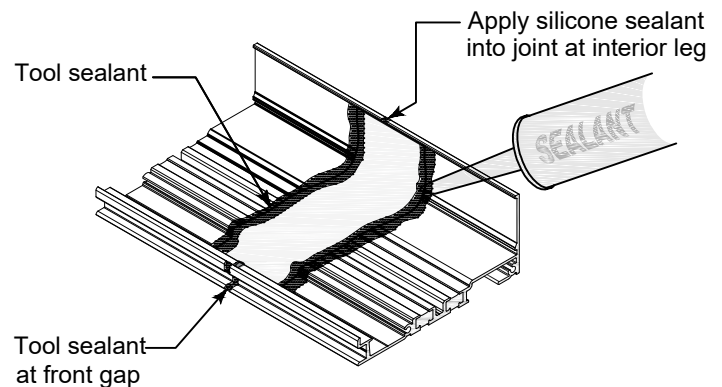
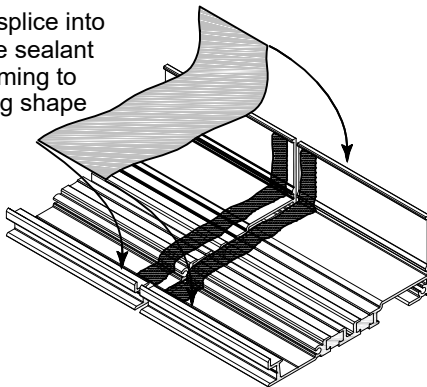

**NOTE:**  
Consult sealant manufacturer  
for compatibility of sealant  
with silicone splice.

Fig. 30.1



## FRAME INSTALLATION

### Step 14: Install Frames

- A. Starting on one side of the opening, apply a bead of silicone to the back leg of the sill flashing and the end dam prior to installing each frame. Apply a sealant bead on the back leg of the flashing only for the frame to be installed.
- B. Lift the first frame onto the sill flashing, snug against the end dam.

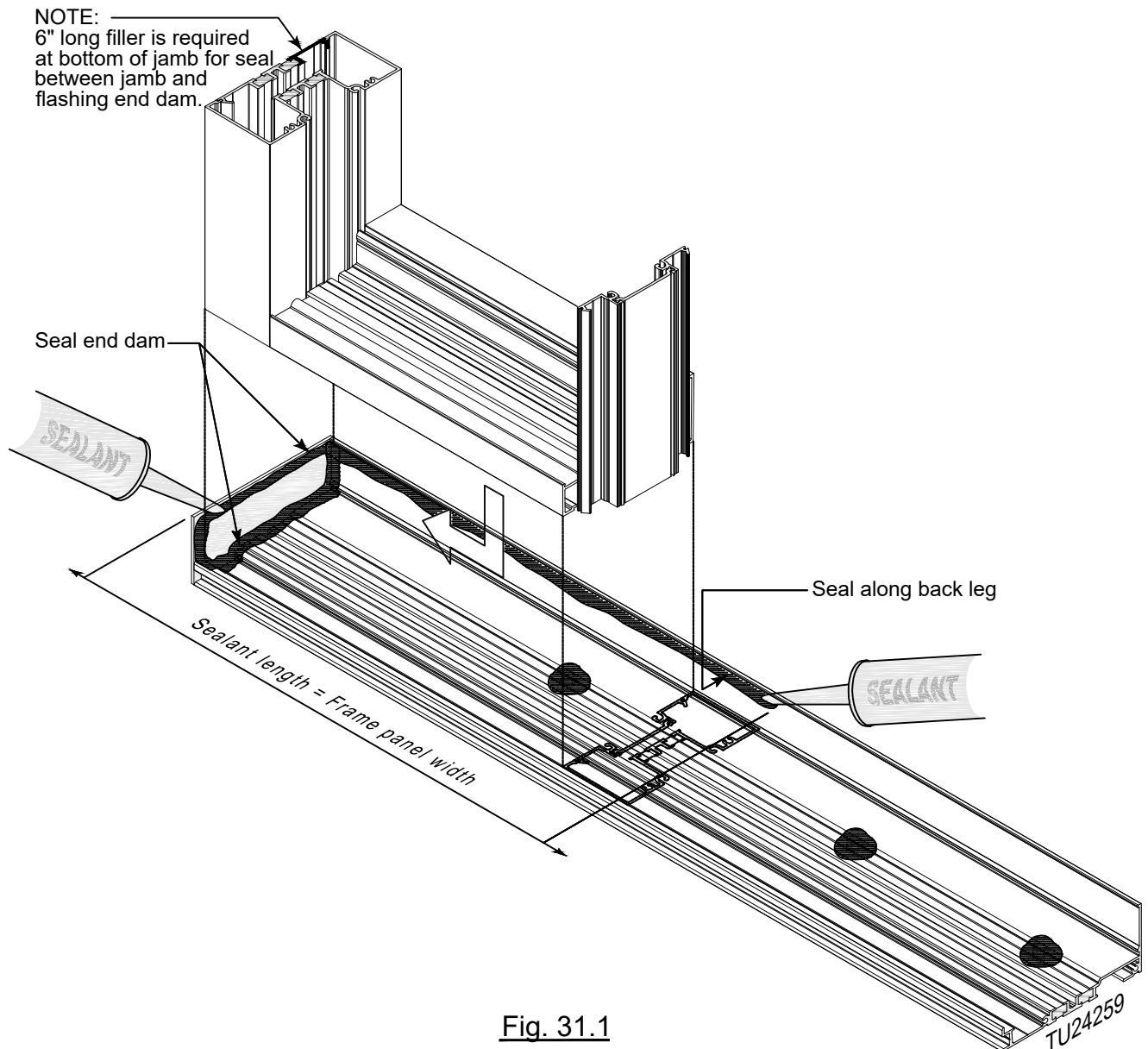

- C. Lift each frame onto the sill flashing and engage with the previous frame.
- D. Check to ensure frame is plumb, level and jamb caulk joint is per approved shop drawings.
- E. Shim head and jamb at anchor points and attach to the building structure. Size, quantity and location of anchors are per approved shop drawings. Remove shims between sill flashing end dams and secure before proceeding.
- F. When the frame is anchored to the structure, apply the exterior perimeter seal at the head, sill and jambs. Interior perimeter seal must be applied to the head, sill and jambs.

**FRAME AT PERIMETER**

**Step 15: Sealing Sill Flashing at Door Jamb**

- A. Install door frame into the opening where sill flashing is discontinued.
- B. Seal the bottom of the door jamb mullion to the building substrate and to the sill flashing.
- C. Fill the door jamb cavity completely and marry to the sill flashing.

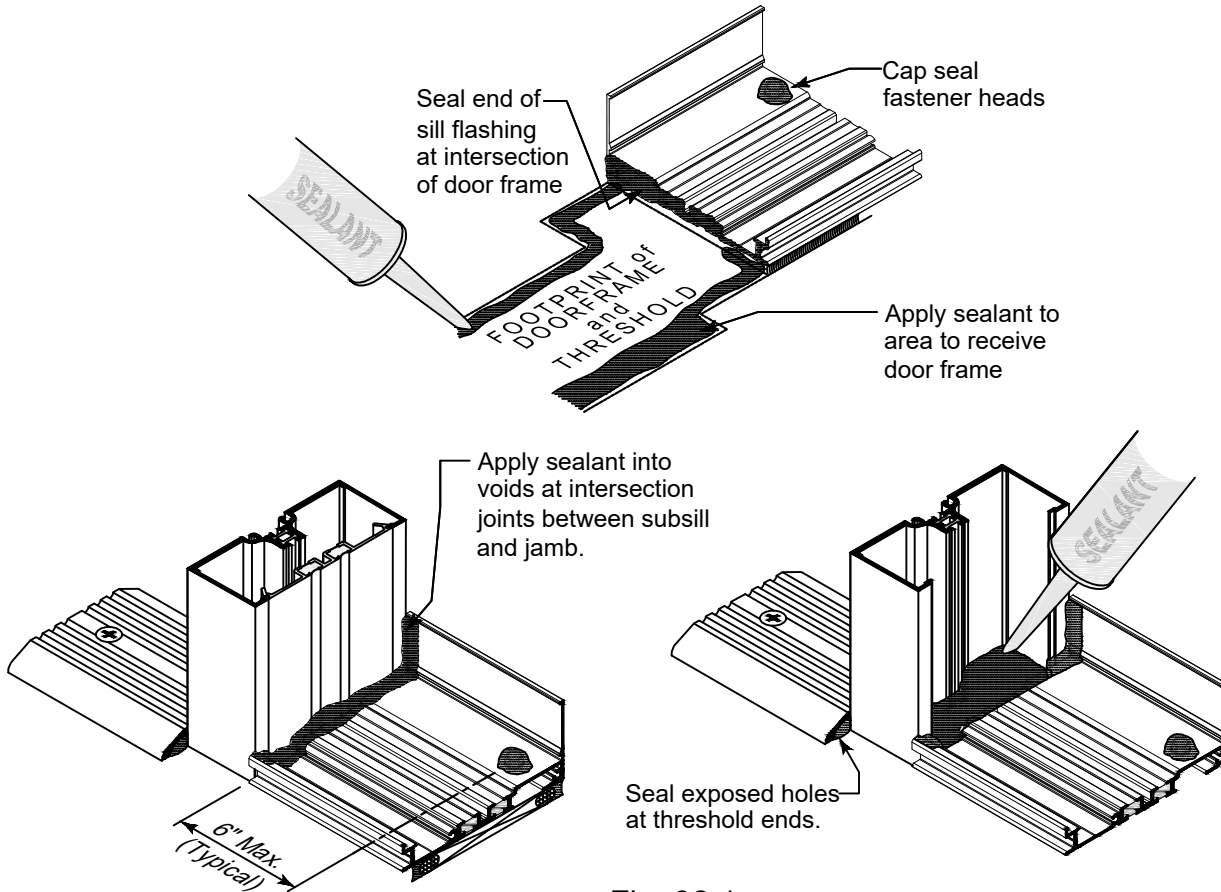

**Fig. 32.1**

**NOTE:**

When a "Knee Wall" occurs within an elevation, the sill flashing must be sealed to intersecting vertical member as shown in Figure 32.2.

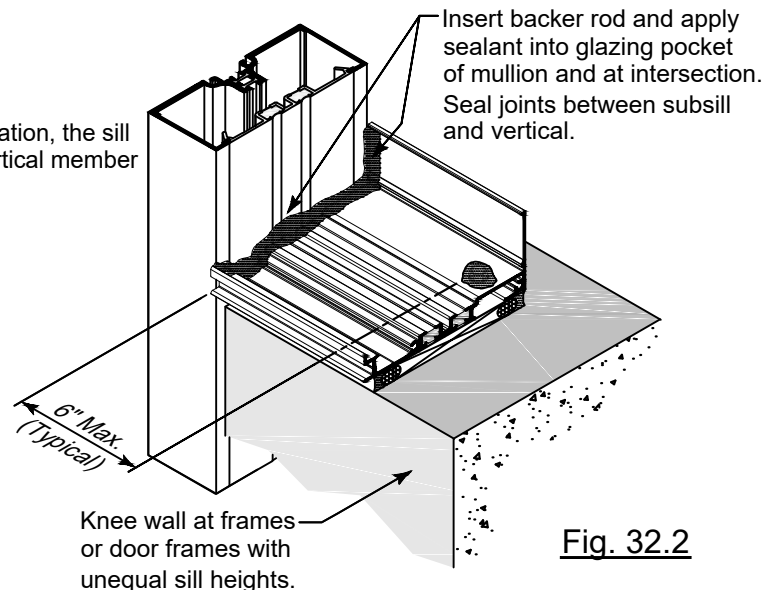

**Fig. 32.2**



## GLAZING

### Step 16: Glazing Preparation

- A. Remove any debris from the glazing pockets.
- B. Trim excess silicone from edges of glazing units to allow for maximum glazing clearance.

Glazing pockets are designed to accept IGU's up to and including 1-1/8" thick. Refer to our online details for a list of glazing size options for this system.

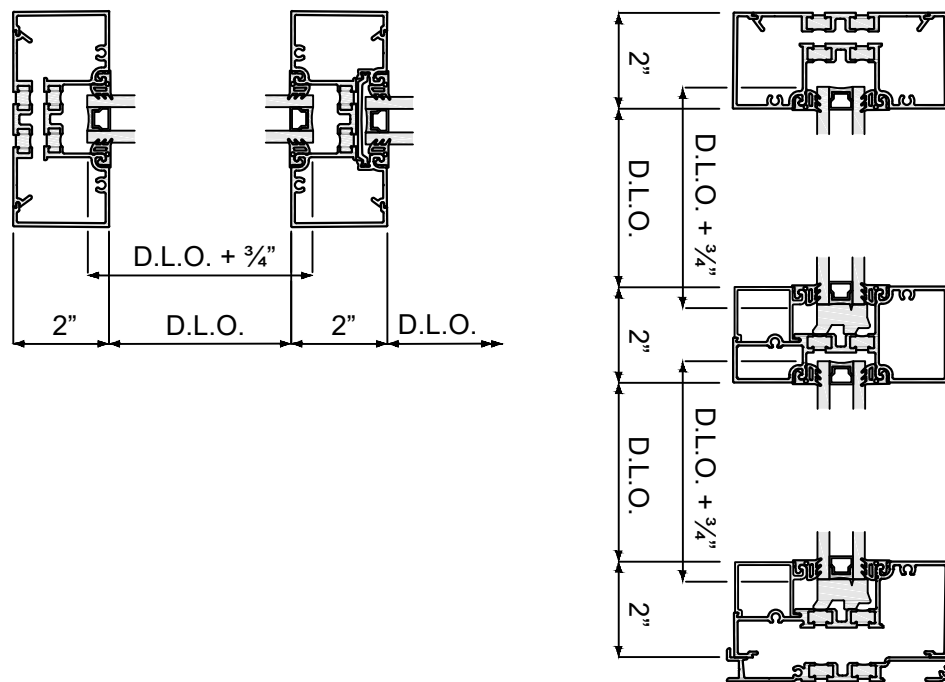

**Fig. 33.1**  
**GLASS LITE SIZES**

## GLAZING

### Step 17: Installing the Glazing Units

NOTE: Glazing must be done from bottom of frame up.

- A. Seal the corners of the previously installed gaskets (refer to Step 11, page 28.).
- B. Set the glass by installing into the deep pocket of the vertical first, then carefully sliding into the shallow pocket. Set glass onto (2) setting blocks located at quarter points or per approved shop drawings. Consult glass manufacturer if glass size exceeds 40 sq. ft.
- C. In applications where glass shifting is anticipated through seismic activity or other forces acting on the frame, install P1917 anti-walk blocks into the deep pocket side of the vertical per glazing manufacturer recommendations.
- D. Install remaining gaskets on the vertical sides of the glass, holding back at the bottom to allow for glass stop installation.
- E. Install glass stop at the bottom of the lite.
- F. Pump sealant into glazing reglet 1" away from each corner and the horizontal-to-vertical joint from the water diverter up to the glazing reglet.
- G. Finish installing gaskets at top and bottom of D.L.O.
- H. Repeat steps 17 A-G for the remaining row of lites.
- I. Prior to glazing the next row of lites, install water diverter P1135 at ends of intermediate horizontals. See Figure 34.1.

NOTE: Position water diverter to cover glass corner. Seal diverter to horizontal, leaving the gap at the front and side open in the vertical glazing pocket. See Figure 34.1 & Figure 34.2. Also see isometric details on page 35.

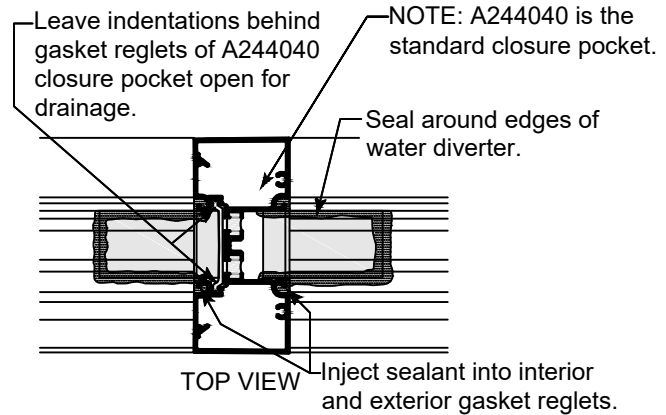

Fig. 34.1

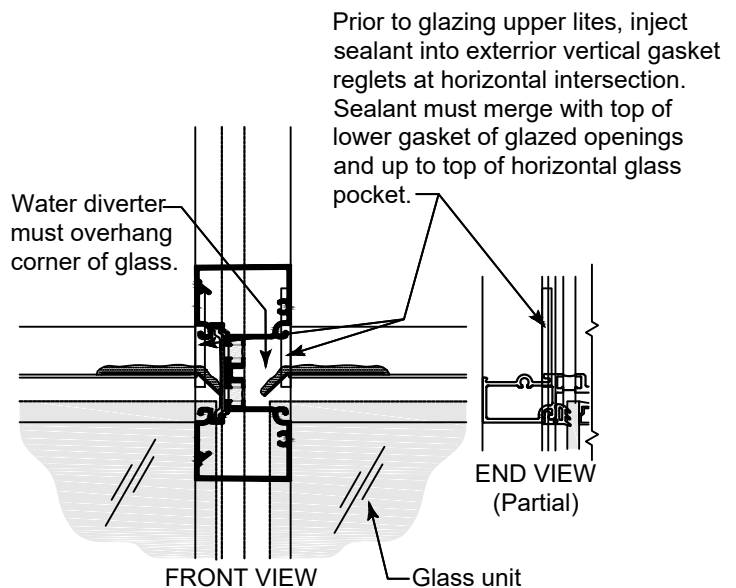

Fig. 34.2

## GLAZING

### Step 17: Installing the Glazing Units (Continued)

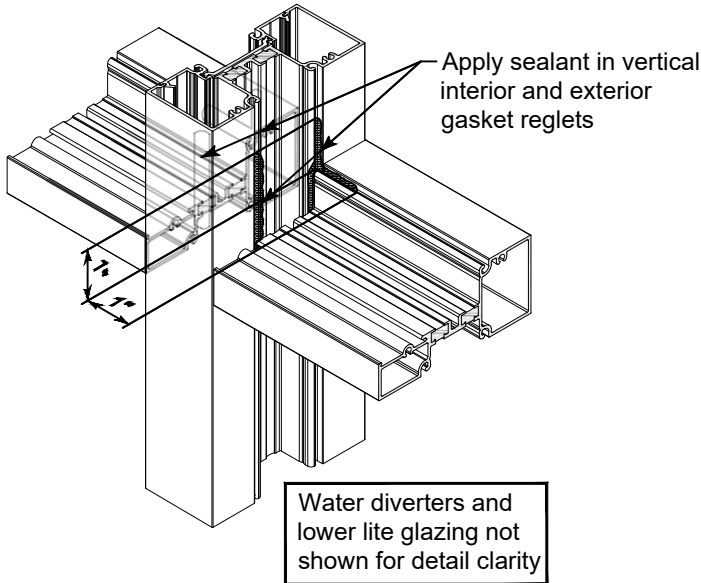

Fig. 35.1

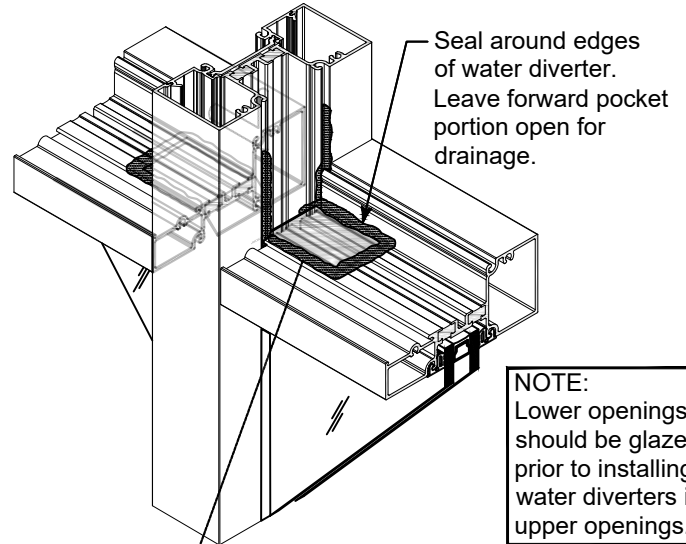

Fig. 35.2

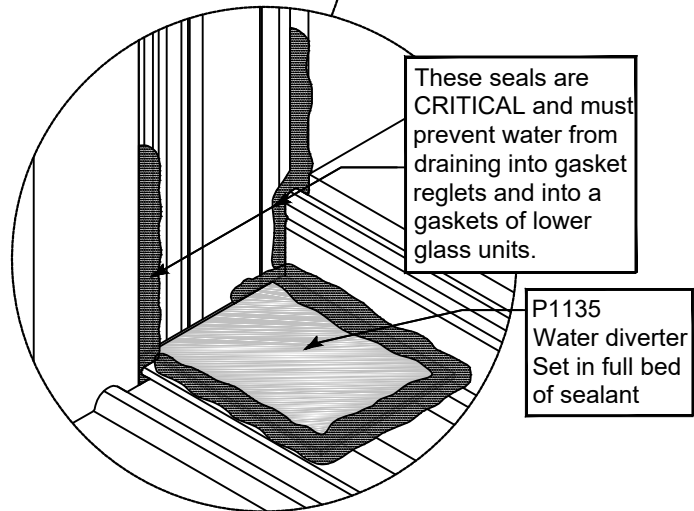
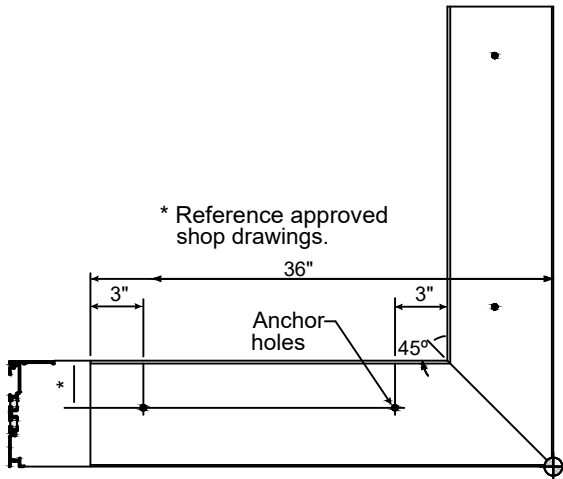

Fig. 35.3

**CORNER CONDITIONS**

**Step 1: Corner Sill Flashing Fabrication**

- A. Miter ends of sill flashing as shown in Figures 36.1, 36.2, 36.3 & 36.4. (One left hand and one right hand.)
- B. Drill anchor holes as shown.



90° OUTSIDE CORNER

Fig. 36.1

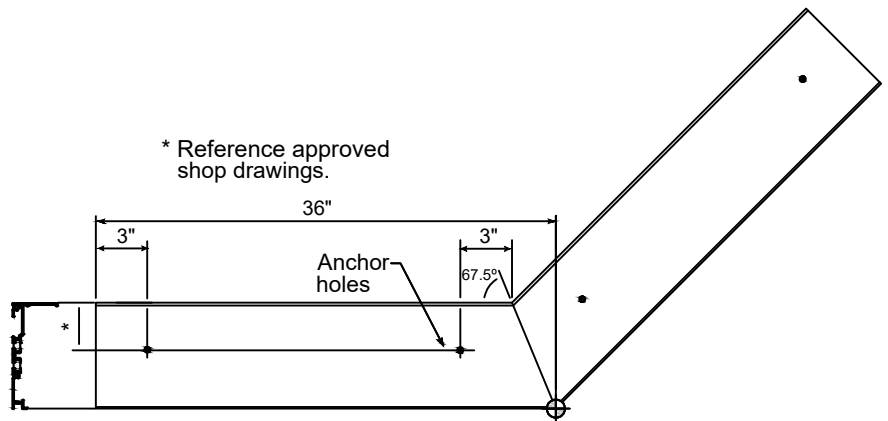

135° OUTSIDE CORNER

Fig. 36.2

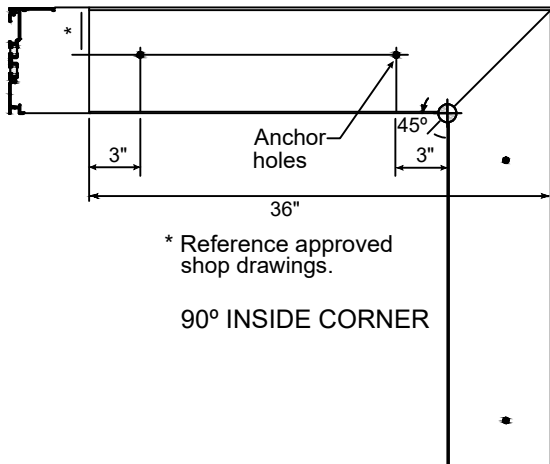

90° INSIDE CORNER

Fig. 36.3

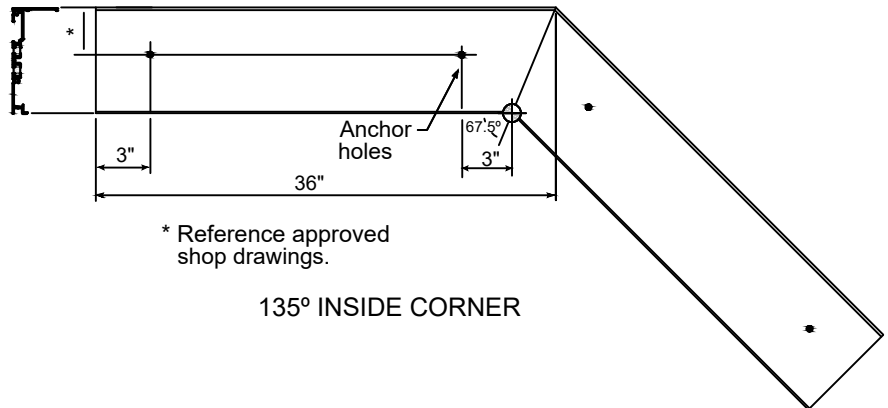

135° INSIDE CORNER

Fig. 36.4

## CORNER CONDITIONS

### Step 2: Corner Sill Flashing Installation

- A. Install flashing corner members in place.
- B. Apply sealant full length of mitered joint. See Figure 37.2.
- C. Splice corner flashing to sill flashing using procedures shown on page 30 and Figure 30.1.

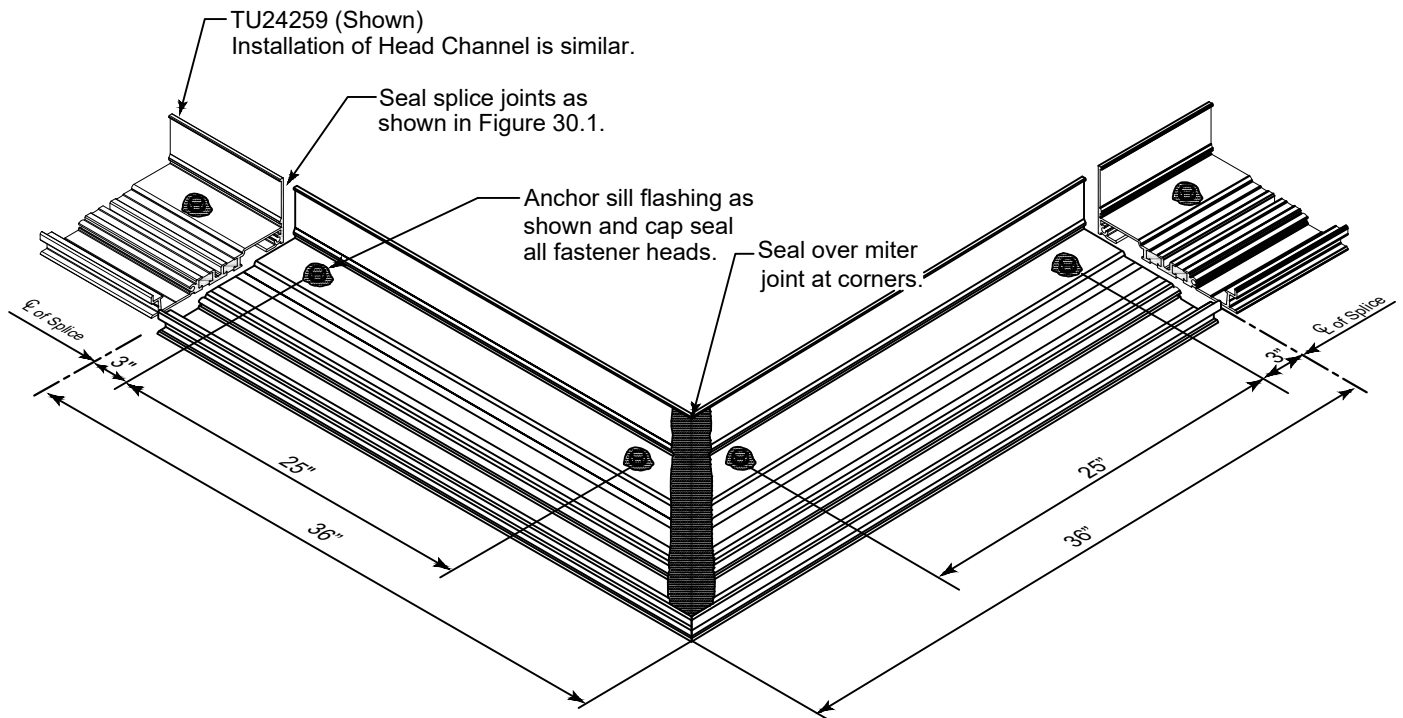

Fig. 37.1

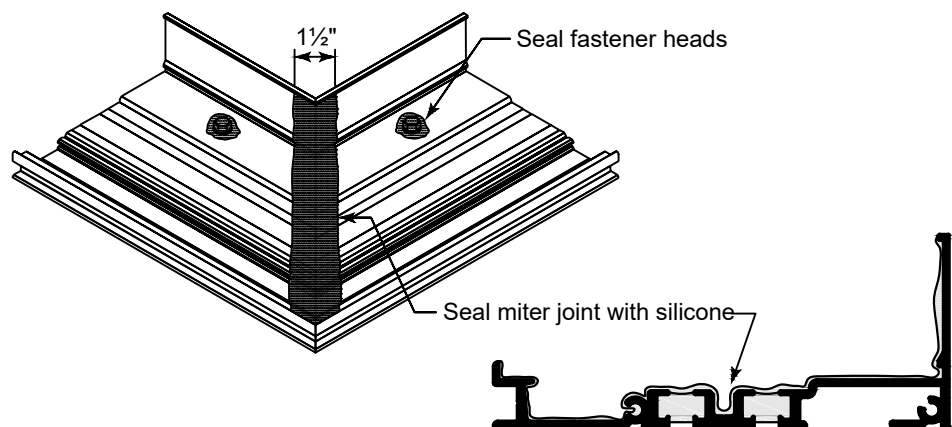

Fig. 37.2

## CORNER CONDITIONS

### Step 3: Assemble Frames

A. Assemble corner bay frames as a unit and set onto the sill flashing. See Figure 38.1.

NOTE: For 135 degree corners, deep pocket closures must be used (A244040 (shallow) or A245050 (deep)).

B. Complete the installation per standard instructions within this manual.

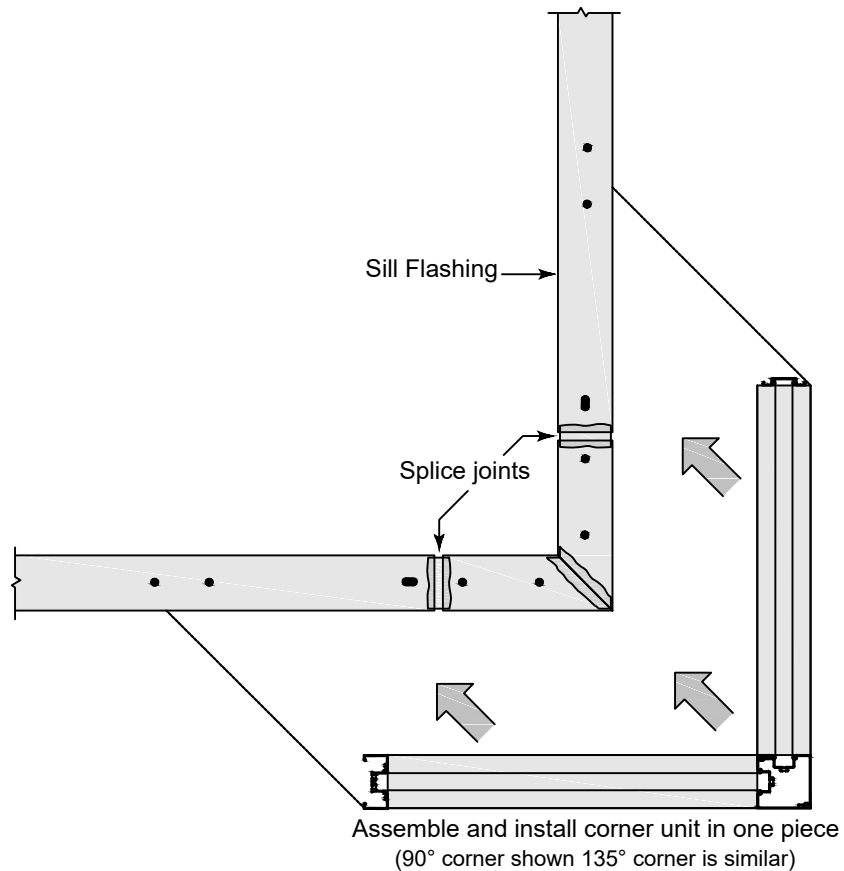

Fig. 38.1

## OPTIONAL NARROW SIDELITE BASE

### Step 1: Assemble Frames

- A. Install P4563 snap-in filler at bottom of vertical
- B. Install backer rod in vertical pocket at top of P4563. Seal over to avoid water penetration into vertical.
- C. Drill for and attach P1137 clip as shown.

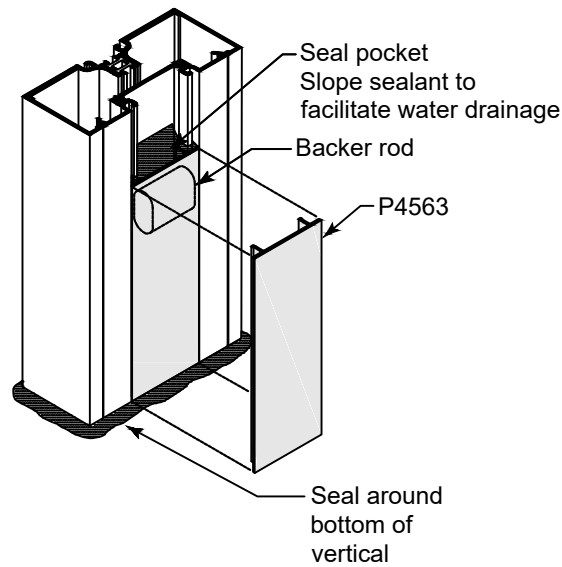

Fig. 39.1

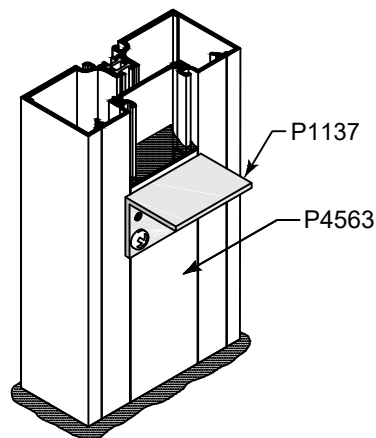

Fig. 39.2

## INSIDE GLAZE

### INSIDE GLAZING GUIDELINES

For inside glazing applications, refer to Figure 40.1 for screw spline assembly and Figure 26.1 for shear block assembly. Follow standard instructions for fabrication, assembly and glazing of inside glazed applications.

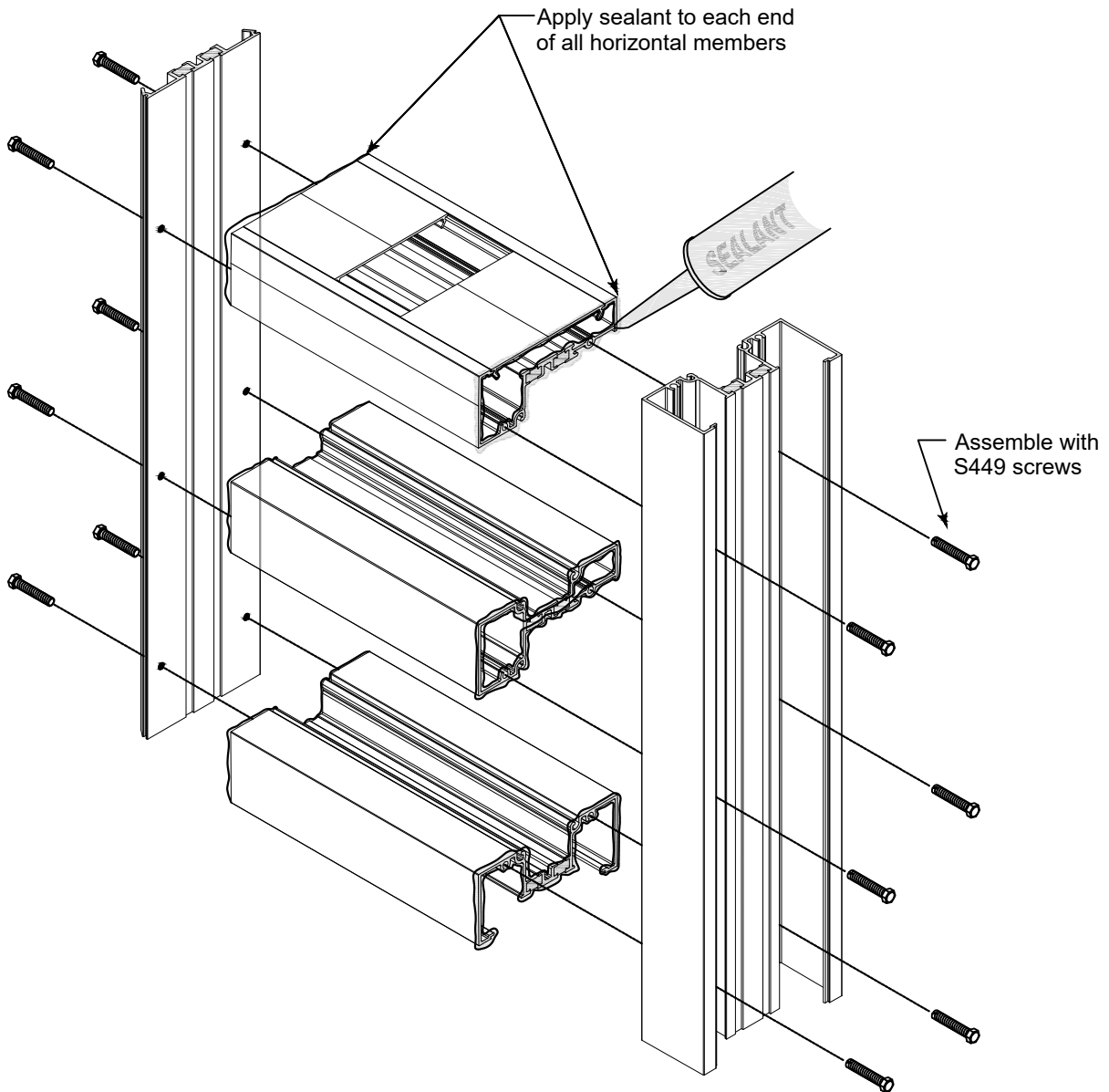

Fig. 40.1



## INSIDE GLAZE

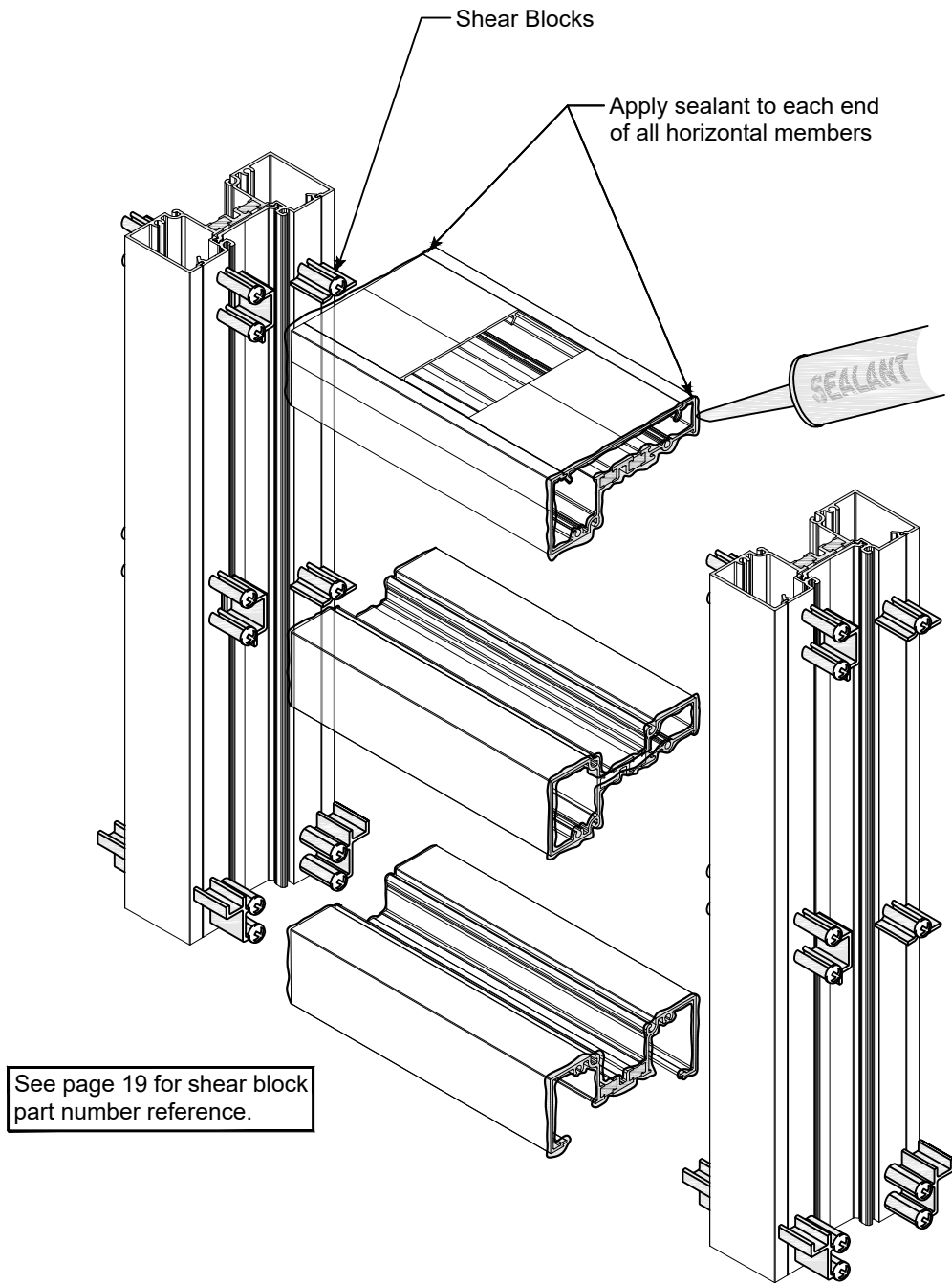

Fig. 41.1