

**To Protect Your Warranty, Use Only ENERPAC Hydraulic Oil.**

Enerpac recommends that all kit components be installed to insure optimum performance of the repaired product.

**Note: Storing the pump in the vertical position may cause it to lose its prime. If pump loses its prime:**

1. Remove cover.
2. Remove relief valve.
3. Fill chamber with oil.
4. Apply Loctite 545 to threads and torque to 10-12 ft-lbs. [14-16 Nm].
5. Replace pump cover. See Figure 1 for gasket orientation detail and cover screw torquing sequence.

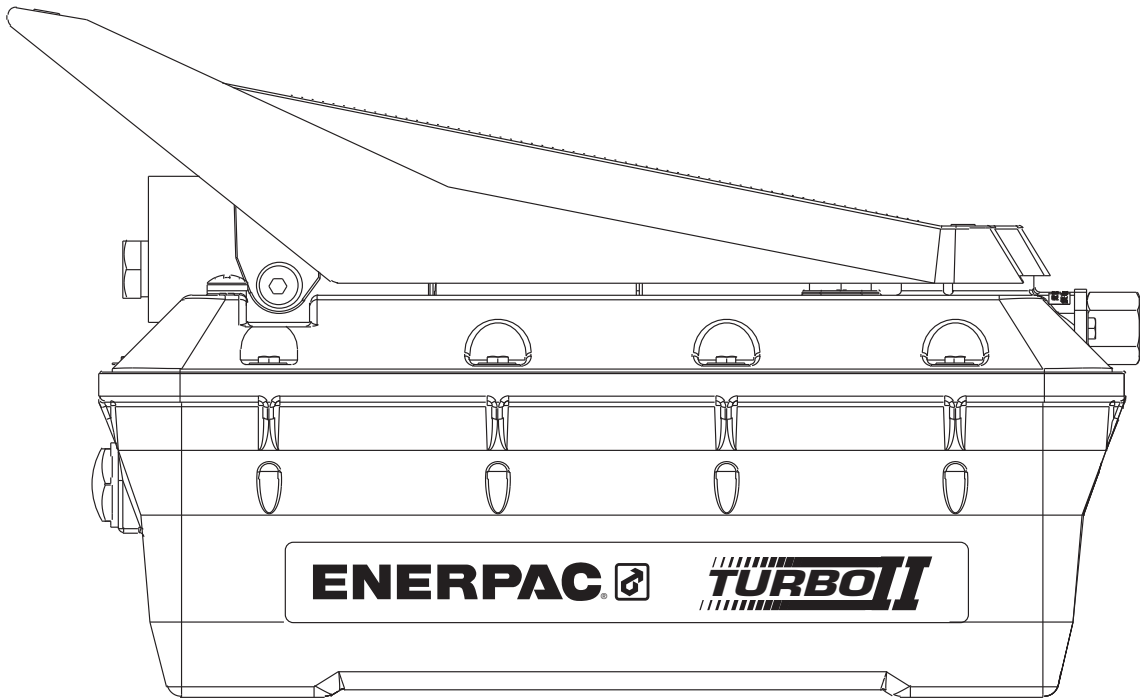

**Contents:**

Figure 1 — Treadle Assembly, T Version.....	2	Figure 7 — Air Motor Assembly .....	8
Figure 2 — Treadle Assembly, M, C, S Version.....	3	Figure 8 — Release Valve.....	9
Figure 2a & 2b — Handle Assembly, R Version .....	4	Figure 9 — Manual Valve.....	10
Figure 3 — Cover Assembly.....	5	Figure 10 — Pump Manifolds, PAS Version .....	11
Figure 4 — Hydraulic Section Detail.....	6	Figure 11 — Pump Manifold, PAC Version.....	11
Figure 5 — Seal Push Tool .....	7	Table 1 — Relief Valve Setting.....	12
Figure 6 — Seal Push Tool .....	7	Table 2 — Repair Kit Application.....	12

\* Turbo II original release starts at Date Code “C”.

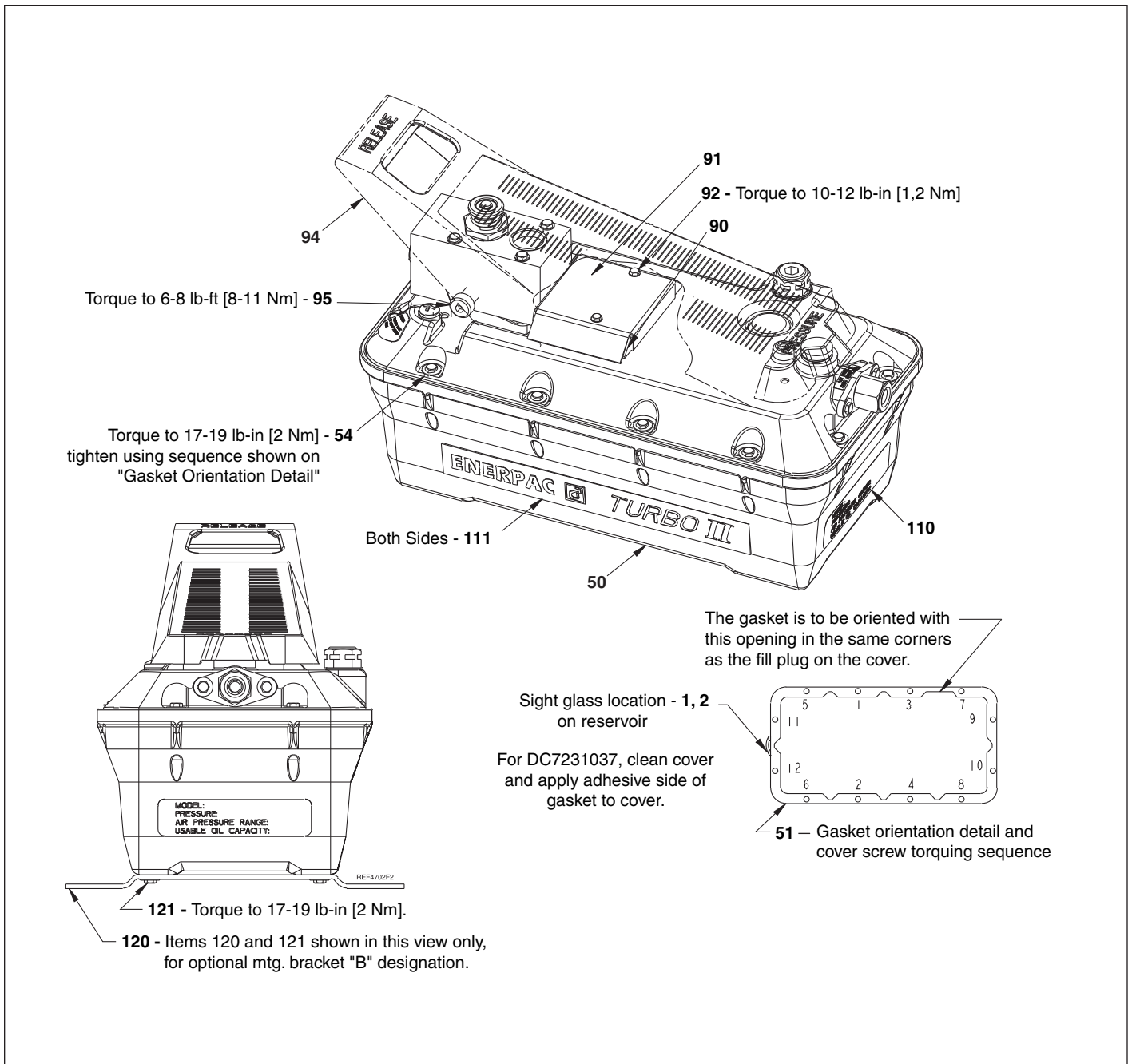

Figure 1, Treadle Assembly, T Version

Repair Parts List for Figure 1							
Item	Part Number	Qty.	Description	Item	Part Number	Qty.	Description
1	DA12288022	1	Sight Glass	91	DA5690098	1	Muffler Cover
2	★ B1908503	1	O Ring	92	DC7851028	2	Hi Lo Screw
50	DC4321900SR	1	Reservoir, 2 L, Yellow	94	DA4849218	1	Treadle
	DC4322900SR	1	Reservoir, 2 L, Black	95	DA4236242	2	Shoulder Screw
	DC4323900SR	1	Reservoir, 2 L, Red	110	DA4296026	1	Model No. Decal
	DC4320900SR	1	Reservoir, 5 L, Black	111	DC2262026	2	Decal, Enerpac Turbo II Blk
51	★ DC4027167	1	Reservoir Gasket, 2 L		DC2260026	2	Decal, Enerpac Turbo II Wht
	†★ DC7231037	1	Reservoir Gasket, 5 L (foam)	120	DA5389111	2	Mtg. Bracket
54	DA5938028	12	Hi Lo Screw	121	DA5938028	4	Hi Lo Screw
	DA8625116	1	Muffler				

★ Items included in Pump Repair Kit, see Table 2 on page 12.

† Replaces DC714517 O-ring gasket.

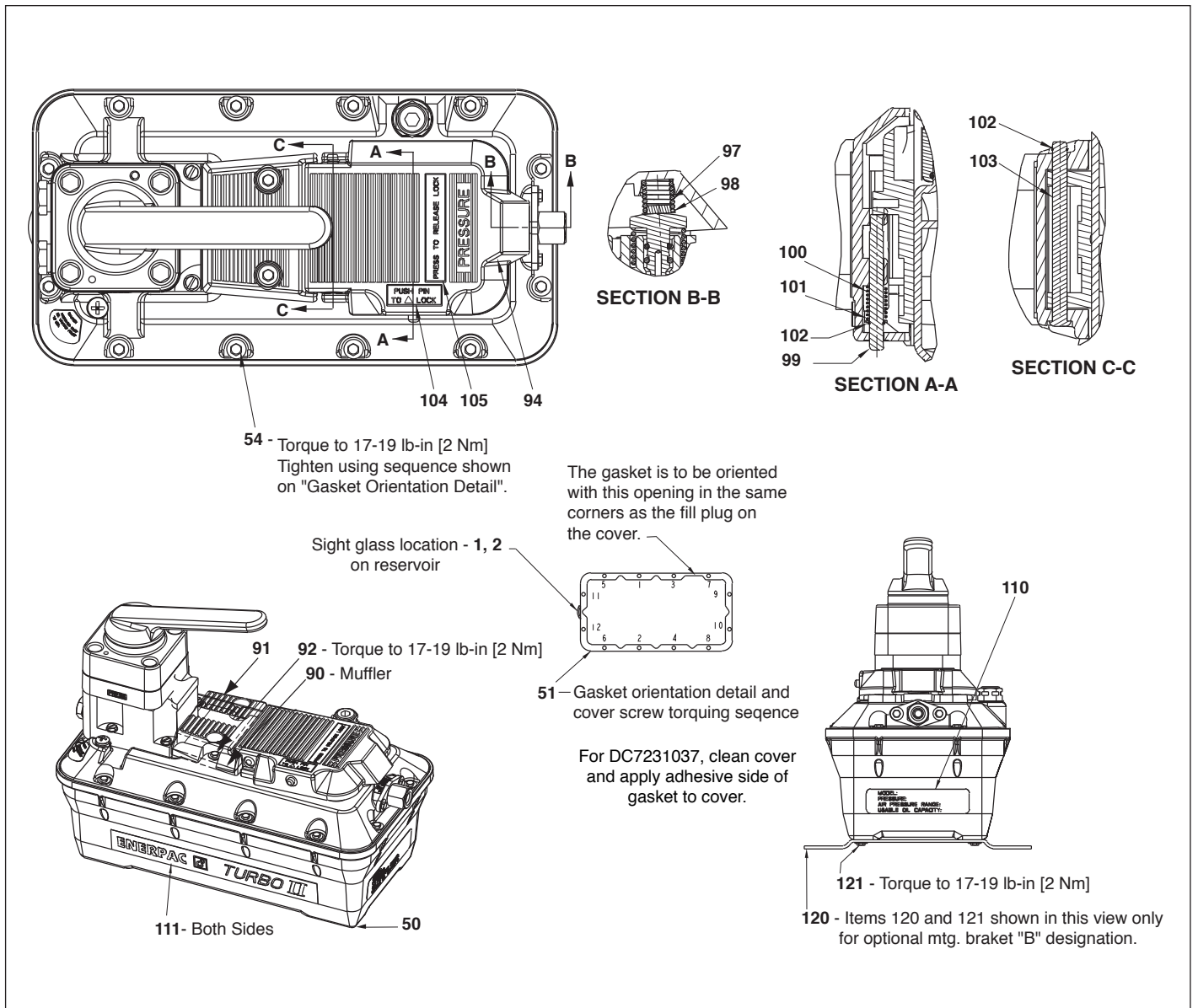
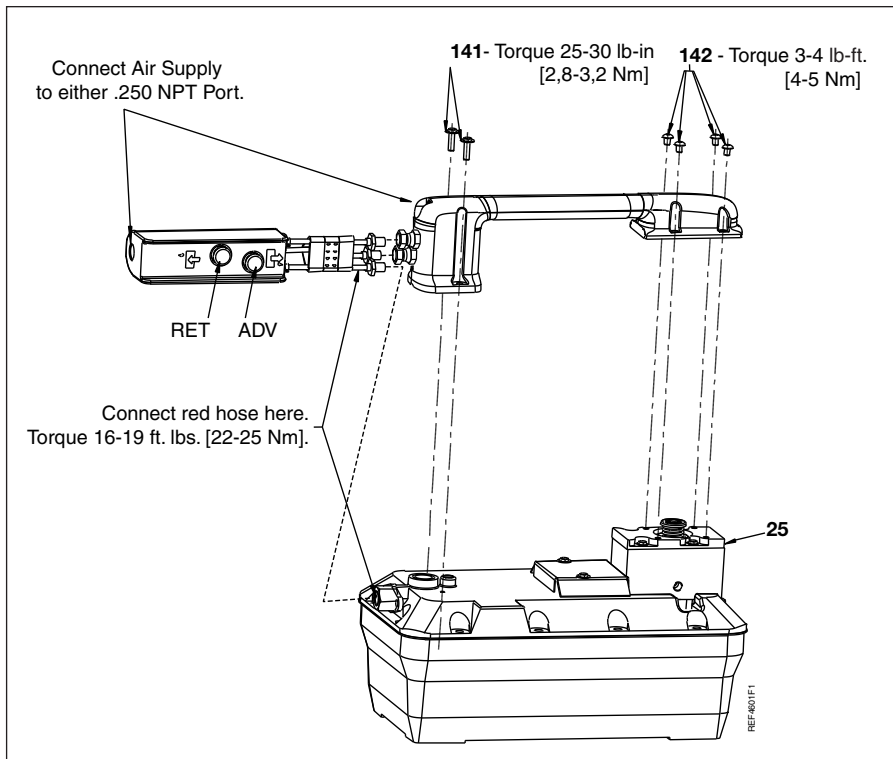

Figure 2, Treadle Assembly, M, C, S Version

Repair Parts List for Figure 2							
Item	Part Number	Qty.	Description	Item	Part Number	Qty.	Description
1	DA12288022	1	Sight Glass	97	DA8506110	1	Spring
2	★ B1908503	1	O Ring	98	DA8670013	1	Spring Guide
50	DC4321900SR	1	Reservoir, 2 L, Yellow	99	DA7940061	1	Latch Pin
	DC4322900SR	1	Reservoir, 2 L, Black	100	DA8508110	1	Spring
	DC4323900SR	1	Reservoir, 2 L, Red	101	DA8505186	1	Spacer
	DC4320900SR	1	Reservoir, 5 L, Black	102	DA5025349	2	Ret. Ring
51	★ DC4027167	1	Reservoir Gasket, 2 L	103	DA7939061	1	Hinge Pin
	†★ DC7231037	1	Reservoir Gasket, 5 L (foam)	104	DA8744026	1	Decal
54	DA5938028	12	Hi Lo Screw	105	DA8743026	1	Decal
90	DA8625116	1	Muffler	110	DA4296026	1	Model No. Decal
91	DA7935111	1	Mtg. Bracket Casting Muffler Cover	111	DC2262026	2	Decal, Enerpac Turbo II Blk
				DC2260026	2	Decal, Enerpac Turbo II Wht	
92	DA5938028	4	Hi Lo Screw	120	DA5389111	1	Mtg. Bracket
94	DA7937218	1	Treadle	121	DA5938028	4	Hi Lo Screw

★ Items included in Pump Repair Kit, see Table 2 on page 12.  
† Replaces DC714517 O-ring gasket.



Repair Parts List for Figure 2a			
Item	Part Number	Qty.	Description
25	DC2355186	1	Valve Spacer
141	* DA5938028	2	Hi Lo Screw
142	* B1322028	4	10-32 x .50 Screw
* Items included in DD1725070K Handle Retrofit Kit.			

Figure 2a, Remote Pendant Turbo Pump Assembly

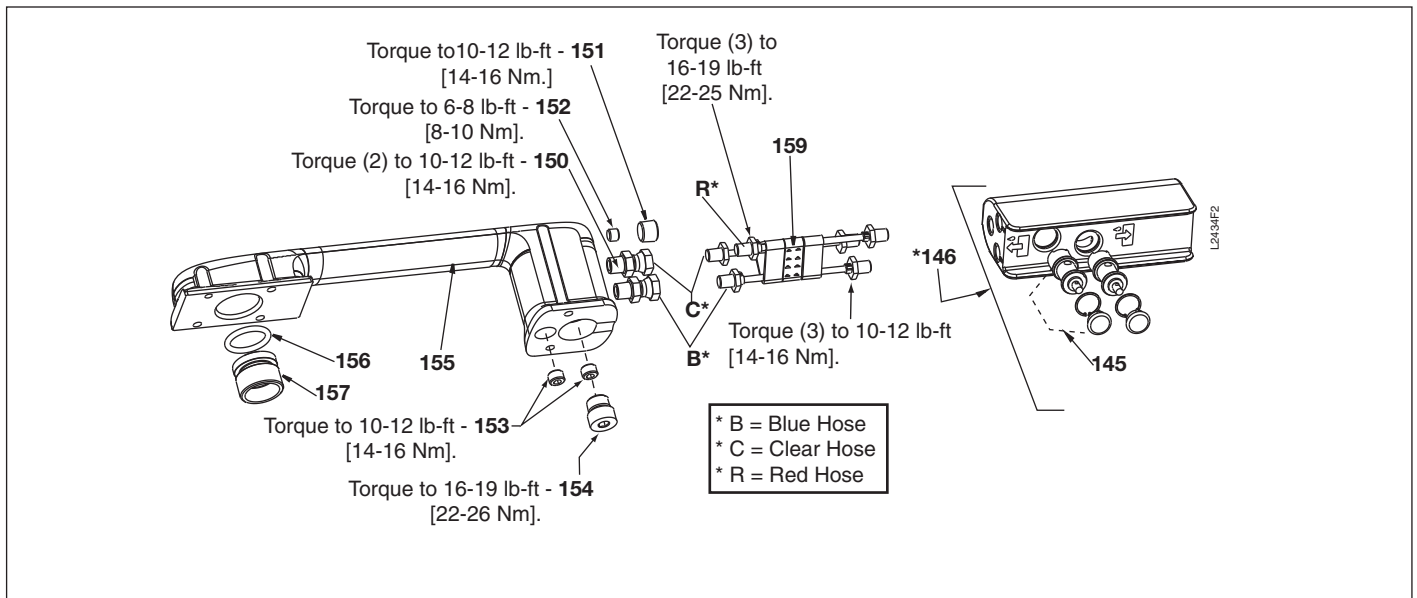

Figure 2b, Pendant Handle Assembly

Repair Parts List for Figure 2b							
Item	Part Number	Qty.	Description	Item	Part Number	Qty.	Description
145	DC2363660SR	2	Air Cartridge Valve	154	* B1005006	1	#6 SAE Hex Plug
146	DC2354840SR	1	Air Pendant Assy. (includes No. 145)	155	◆*★ DC2347070	1	Handle Assembly
150	DC2367006	2	1/8" NPT Swivel Fitting	154	* B1019503	1	O-ring 70 DUPR-213
151	* A1008245	1	Hex Plug	157	◆*★ DC473051	1	Pneumatic Dump Piston
152	* A1006245	1	1/16 Flush Plug w/Sealant	159	DC2365646SR	1	Hose Assembly
153	* A1007245	2	1/8 Flush Plug w/Sealant				

★ Items included in Pump Repair Kit, see Table 2 on page 12.

\* Items included in DD1725070K Handle Retrofit Kit.

◆ Handle (item 155) and piston (item 157) MUST be replaced as a set. Old and new parts are NOT interchangeable.

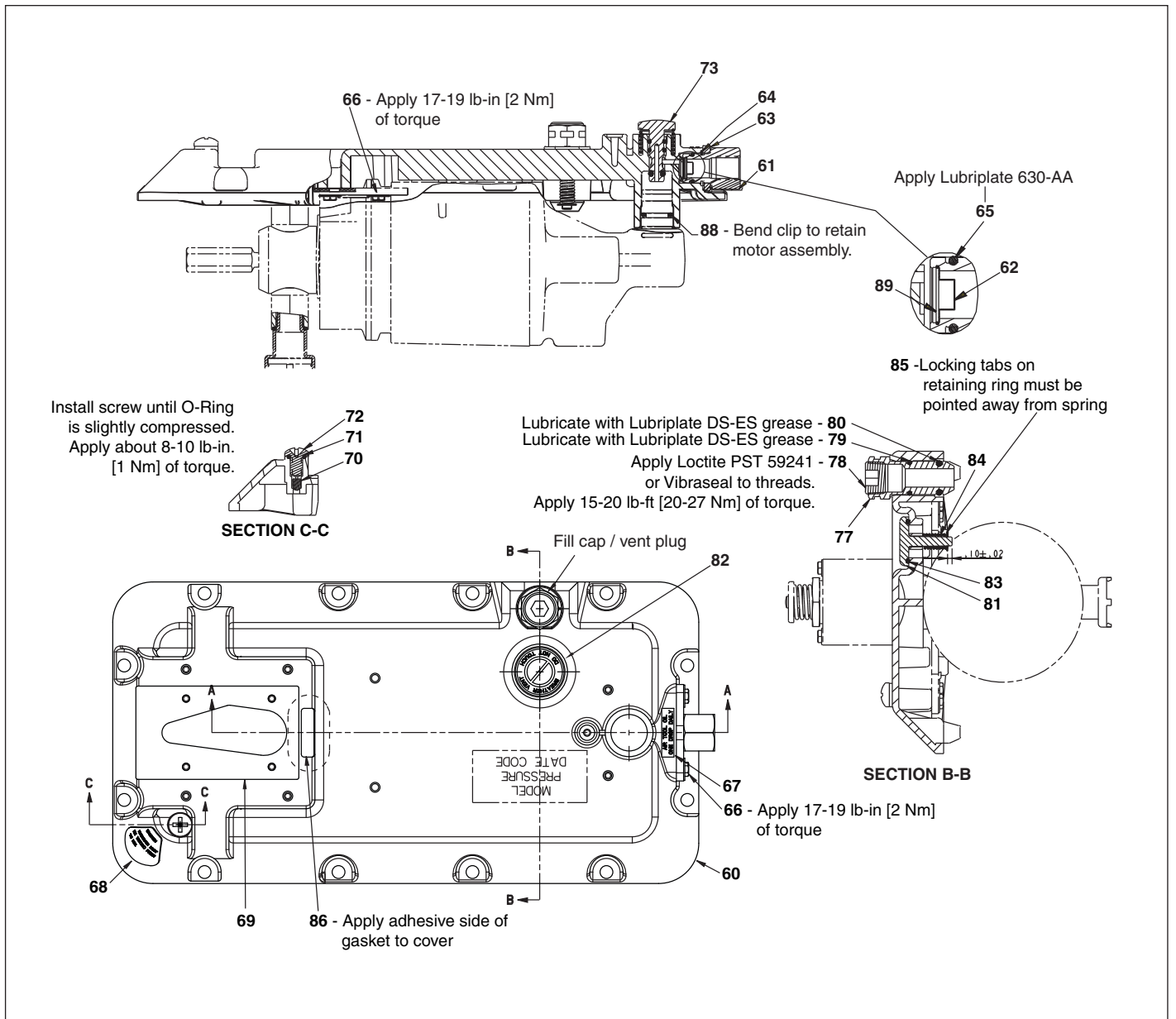

Figure 3, Cover Assembly

Repair Parts List for Figure 3

Item	Part Number	Qty.	Description	Item	Part Number	Qty.	Description
60	DC3913900SR	1	Blk Cover Assy. (incl 61-87)	73	DA4802051SR	1	Air Button
	DC3914900SR	1	Red Cover Assy. (incl 61-87)	77	DA4871118	1	Breather
61	DA5295034	1	Swivel Coupler	78	A1009245	1	3/8 Flush Plug W/Sealant
62	★ A8001018SR	1	Filter	79	★ DA5349503	1	O Ring (Wear Coated)
63	DA4847799	1	Stamped Bracket	80	★ B1010503	1	O Ring
64	DA5026349	1	Ret. Ring	81	DC708440	1	Poppet
65	★ B1220503	1	O Ring Ref B839503	82	U972038026-2	1	Breather Vent Decal
66	DA5938028	6	Hi Lo Screw	83	B1224503	1	O Ring Ref J711041
67	U972038026-3	1	Air Tool Oil Decal	84	DC821110	1	Compression Spring
68	DA7931026	1	Caution Decal	85	DC4077160	1	3/16" Retainer
69	★ DC4997900K	1	Gasket Set	86	†★ DA6956037	1	Gasket
70	★ DA4390118	1	Filter	88	★ DA5521149	1	Retaining Pin
71	★ B1005503	1	O Ring	89	★ DC5217049	1	Retaining Ring
72	★ DC7838028	1	1/4 x 3/8" Hi Lo Screw				

★ Items included in Pump Repair Kit, see Table 2 on page 12.

† Replaces and interchangeable with gasket DC7872037.

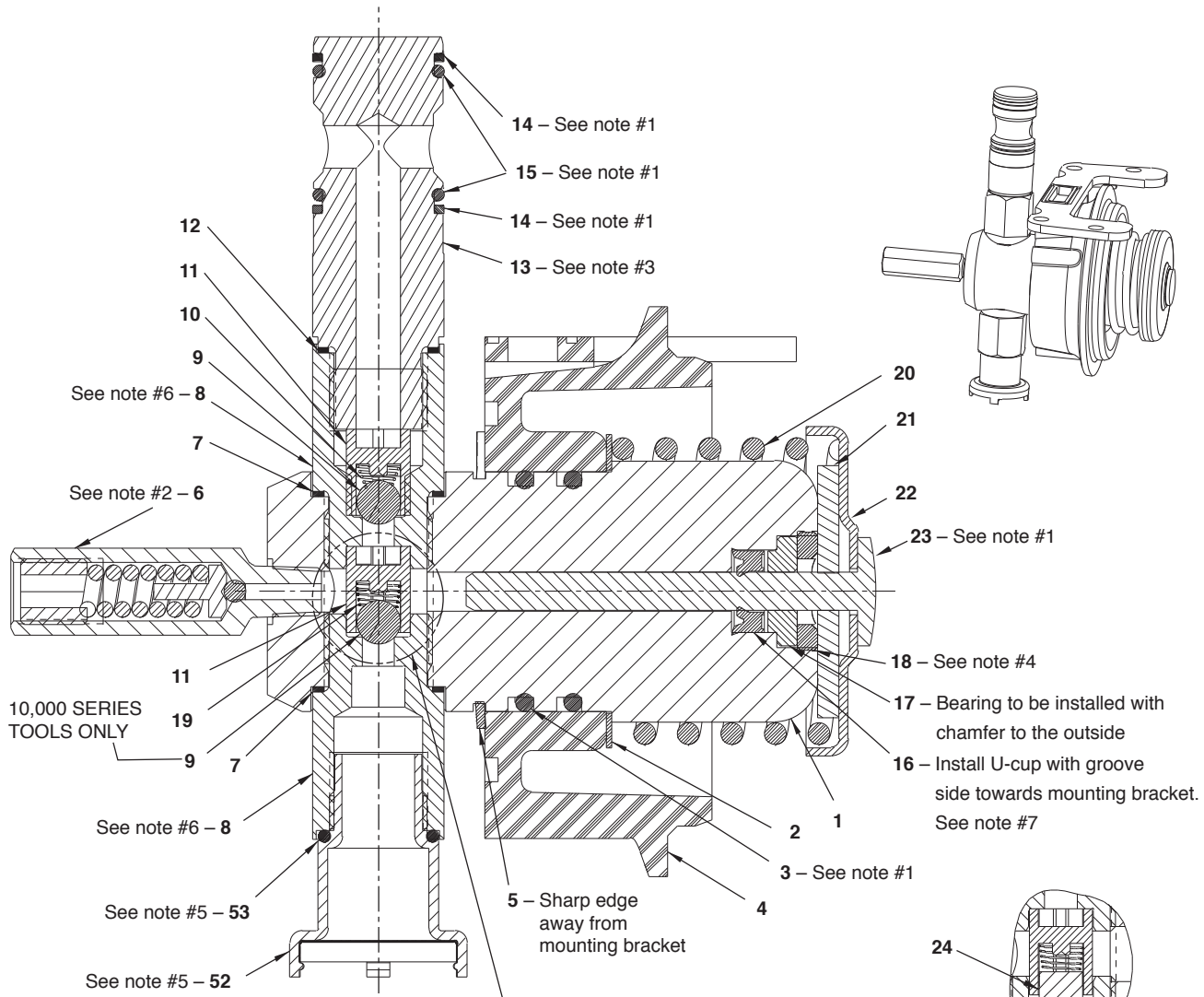

**SECTION A-A**

10,000 SERIES TOOLS ONLY

**DETAIL B**

**DETAIL B**

3,000 AND 5,000 SERIES TOOLS ONLY

**Notes:**

1. Lubricate seals with moderate amount of DS-ES grease.
2. Apply Loctite 545 on threads, and apply 10-12 lb-ft [14-16 Nm] of torque to item #6.
3. Apply a 1/2 bead of Loctite 243 on threads and apply 34-41 lb-ft [46-55 Nm] of torque to item #13.
4. Apply one drop of Loctite 242 on threads, and apply 10-12 lb-ft [13,6-16,3 Nm] of torque to item #18.
5. Items #24 and #25 are installed finger tight.
6. Apply a 1/2 bead of Loctite 243 on threads and apply 38-45 lb-ft of torque to item #8.
7. If the pump comes with a step seal, a step seal should be used for replacement. If the pump comes with a u-cup, it should be replaced with a u-cup.

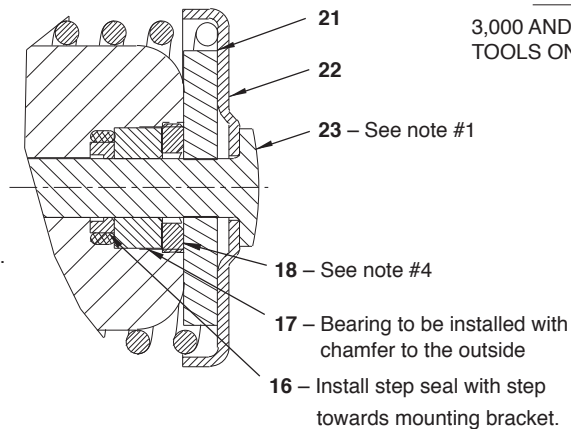

**SECTION A-A**

3,000 AND 5,000 SERIES TOOLS ONLY

**Figure 4, Hydraulic Section Detail**



**Repair Parts List for Figure 4**

Item	Part Number	Qty.	Description	Item	Part Number	Qty.	Description
1	DC116030	1	Hyd. Cylinder, Turbo 3 KSI	17	※★ DA9056108	1	Bearing 3 KSI
	DC115030	1	Hyd. Cylinder, Turbo 5 KSI		✦★ DA5352155	1	Bearing 5 KSI
	DC114030	1	Hyd. Cylinder, Turbo 10 KSI		✧★ CB624108	1	Bearing 10 KSI
2	DA4298108	1	Washer	18	※★ DA7888044	1	Bearing Retainer 3 KSI
3	✦✦✦★ B1258503	2	O-Ring		✦★ DA1204044	1	Bearing Retainer 5 KSI
4	DA4287111	1	Mtg. Bracket		✧★ DA1204044	1	Bearing Retainer 10 KSI
5	DA4343044	1	Bowed Ret. Ring	19	★ DA6911210	1	Conical Spring
6	DA8802900SR	1	Relief Valve Assy	20	DA4285110	1	Spring
7	✦✦✦★ DA3811167	2	Copper Gasket	21	DA9280108	1	Rubber Washer 3 KSI
8	DC283290SR	2	Seat		DA5976108	1	Rubber Washer 5 KSI
9	✦✦✦★ B1007016	2	1/4" Dia. Ball		DA6600108	1	Rubber Washer 10 KSI
10	✦✦✦★ DA4874110	1	Conical Spring	22	DA9281108	1	Spring Washer, Turbo, 3 KSI
11	✦✦✦★ DA3682013	2	Ball Guide		DA4628108	1	Spring Washer, Turbo, 5 KSI
12	✦✦✦★ DC170167	1	Copper Gasket		DA4284108	1	Spring Washer, Turbo, 10 KSI
13	★ DC5268SR	1	Pressure Tube 10 KSI	23	DC6406040	1	Plunger, 3 KSI
14	★ DA4974367	2	Backup Ring		DC6427040	1	Plunger, 5 KSI
15	★ B1016803	2	O-Ring – Global		DC6428040	1	Plunger, 10 KSI
16	※★ DA9269476	1	Step Seal 3 KSI	24	✦✦✦★ DC4440	1	Poppet
	※★ DC64446041	1	U-Cup 3 KSI	52	DC442900SR	1	Intake Tube Assy
	✦★ DC6447041	1	U-Cup 5 KSI	53	✦✦✦★ B1221503	1	O-Ring Ref. C403503
	✦★ DA5351476	1	Step Seal 5 KSI				
	✧★ CB918041	1	U-Cup 10 KSI				

★ Item included in complete Pump Repair Kit. See Table 2 on page 12.

- ※ Item included in Repair Kit DC2220900K for 3,000 Series tools.
- ✦ Item included in Repair Kit DC2221900K for 5,000 Series tools.
- ✧ Item included in Repair Kit DC2222900K for 10,000 Series tools.

**Note:** Items 16, 17 and 18 will vary depending on repair kit ordered. Refer to Figure 4 for installation details.

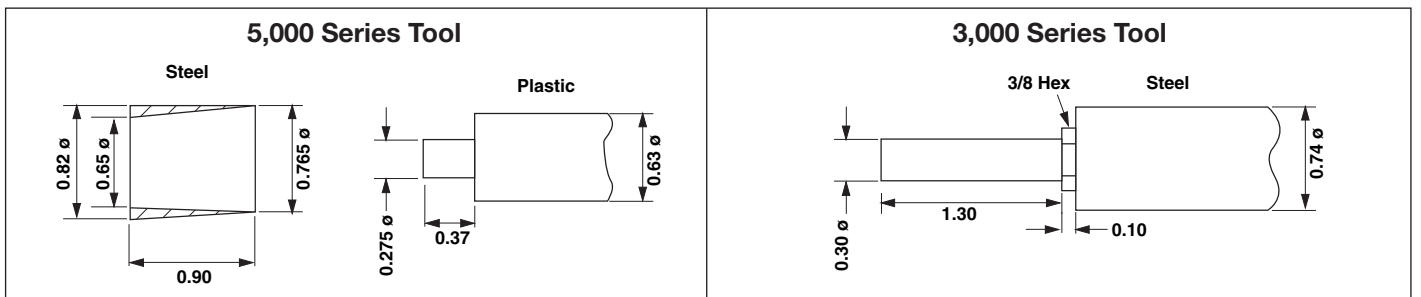

**Figure 5, Seal Push Tool**

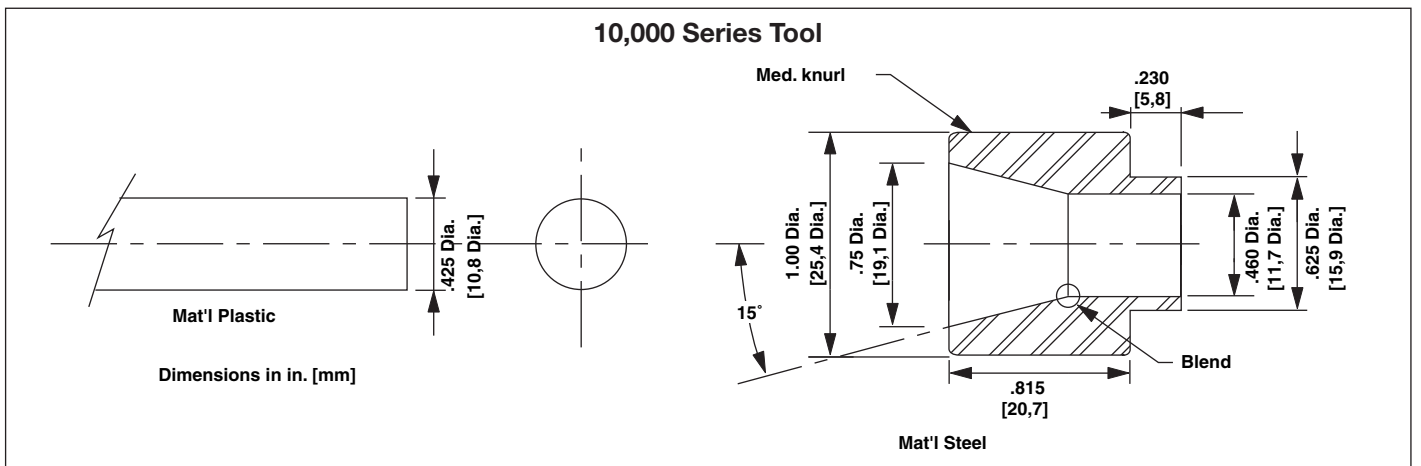

**Figure 6, Seal Push Tool**

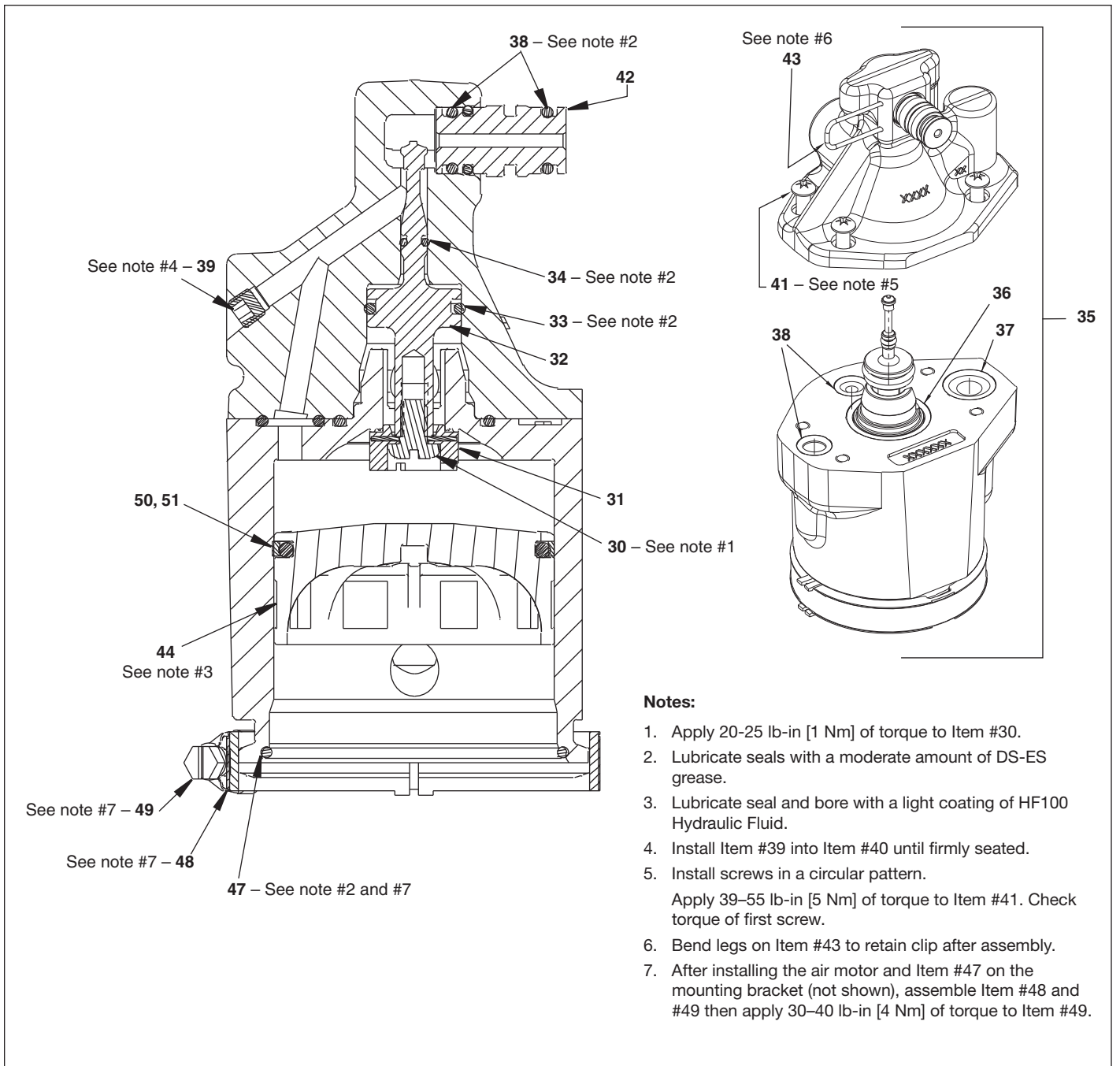

**Figure 7, Air Motor Assembly**

Repair Parts List for Figure 7							
Item	Part Number	Qty.	Description	Item	Part Number	Qty.	Description
30	★ DA7085028	1	Screw - .250-20 Special	41	DC2261628	4	Screw, Torx (.25-20 x .75 lg.)
31	★ DA3706120	1	B/U Washer	42	DC2182099	1	Extension Fitting, Air Motor
32	★ DC2234051	1	Piston	43	★ DA5521149	1	Retaining Pin
33	★ B1013503	1	O-Ring	44	DC4122051SR	1	Air Motor Piston
34	★ B1001503	1	O-Ring (.12 x .25 x .06)	47	★ B1282503	1	O-Ring
35	DC2200900SR	1	Air Motor, Complete	48	DA2687111	2	Clamp Brk.
36	★ B1260503	1	O-Ring	49	DA2686299	1	Hose Clamp
37	★ B1014503	1	O-Ring Ref M760041	50	★ DC4119703	1	O-ring
38	★ B1009503	4	O-Ring Ref K1041	51	★ DC4120141	1	Glyde Ring
39	A1006245	1	1/16 Flush Plug w/Sealant				

★ Items included in and available only as part of Repair Kit DC2234900SR.  
Also included in complete Pump Repair Kit, see Table 2 on page 12.



**Notes:**

1. Torque Item #19 to 72-78 lb-ft [98-105 Nm] with threads lubricated.
2. Torque Item #11 to 17-19 lb-in [2 Nm].
3. Lubricate all seals and mating surfaces w/DS-ES Grease prior to assembly unless otherwise noted.
4. Prior to assembling Item #6 seat, coin seat with a  $\varnothing$  .219 ball to a force of 95-105 lbs. [444 N].

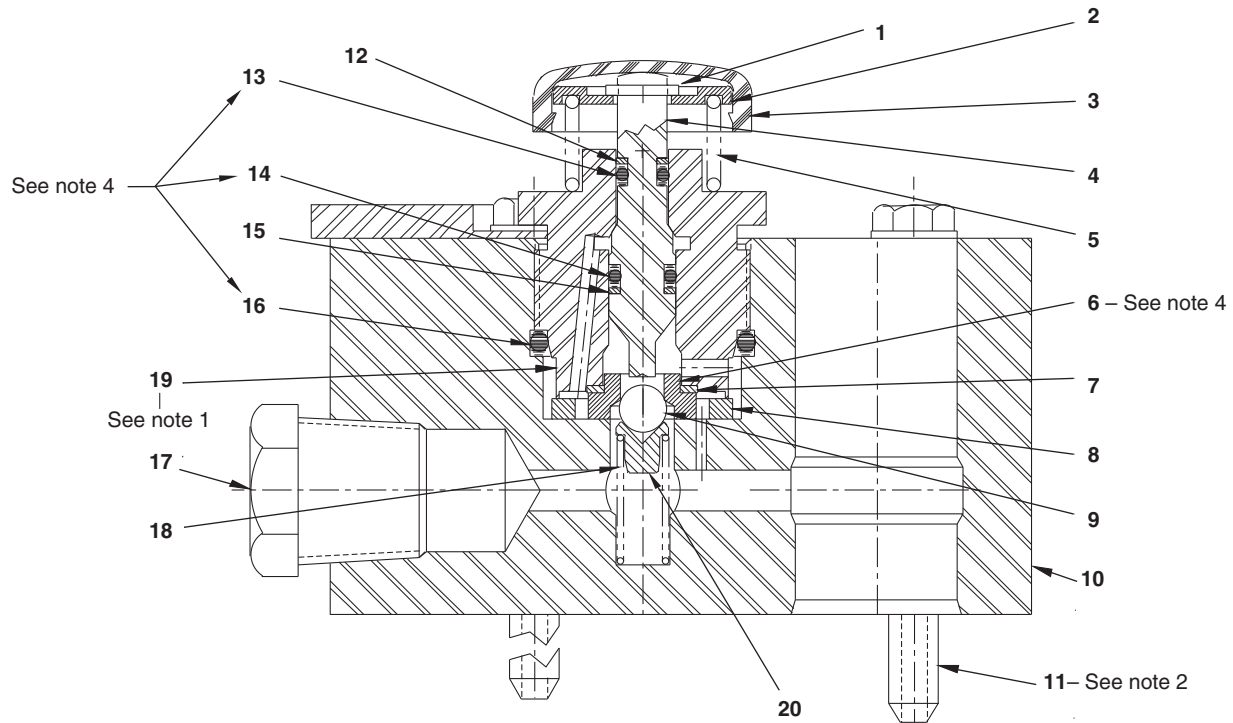

**Figure 8, Release Valve**

**Repair Parts List for Figure 8**

Item	Part Number	Qty.	Description	Item	Part Number	Qty.	Description
1	★ DA5025349	1	Ret. Ring	11	DA4294028	4	Thd. Form Screw
2	DA4848108	1	Spring Washer	12	★ B1006564	1	B/U Washer
3	★ DA4831020	1	Cap	13	★ B1001503	1	O-Ring (.12 x .25 x .06)
4	DA4832040	1	Release Plunger	14	★ B1003503	1	O-Ring (.19 x .31 x .06) BUNA
5	★ DA6971110	1	Spring	15	★ B1008564	1	Back-up Washer
6	★ CB581290	1	Ball Seat	16	★ B1118903	1	O-Ring
7	★ P20037	1	Gasket	17	R515245-2	1	Plug
8	★ CL344167	1	Gasket	18	★ CJ656110	1	Spring
9	★ B1006016	1	7/32" Dia. Ball	19	DA4872013	1	Release Guide
10	DA4833190	1	Manifold	20	★ DA7572013	1	Ball Guide

★ Items included in and available only as part of Repair Kit DA4836900K1.  
 Also included in complete Pump Repair Kit, see Table 2 on page 12.

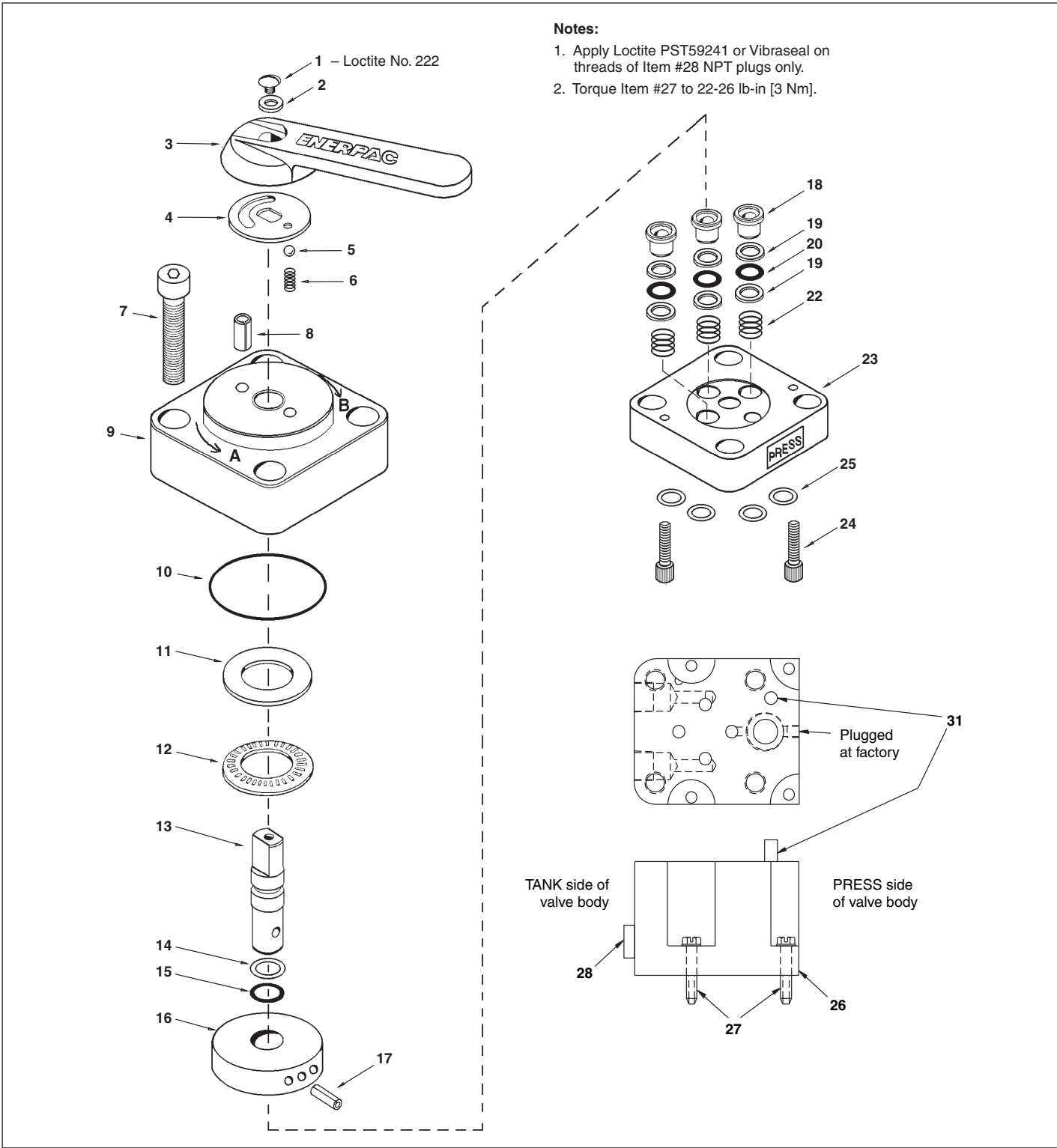

Figure 9, Manual Valve

**IMPORTANT**

Do not attempt to repair the pump by substituting another valve. The 4-way manual valve used on Turbo II pumps is not interchangeable with a standard Enerpac VM-4 valve. Using a valve that is not designed for this mounting configuration may result in the reservoir becoming pressurized during operation.

**For complete replacement valve, order:**

- DA5118900SR for NPT Ports
- DA9744900SR for BSPP Ports

### Repair Parts List for Figure 9

Item	Part Number	Qty.	Description	Item	Part Number	Qty.	Description
1	A8076048	1	Screw	17	B1109057	1	Roll Pin
2	B1086108	1	Washer	18	DA9560041	3	Seal
3	Y325070	1	Handle	19	★ B1011564	6	Back-Up Washer
4	A8005071	1	Disc	20	★ B1006503	3	O-Ring
5	★ B1006016	1	7/32" Ball	22	★ CB28110	3	Spring
6	★ A8039110	1	Spring	23	CH539190	1	Body
7	B1389028	4	Bolt	24	B1326028	2	Bolt
8	B1126057	1	Roll Pin	25	★ B1111803	4	O-Ring
9	CB324001	1	Valve Cap	26	DA5132840SR	1	Manifold - NPT Ports
10	★ B1269503	1	O-Ring		DA9745840SR	1	Manifold - BSPP Ports
11	CB327101	1	Bearing Plate	27	DC1523028	4	Screw
12	CB328281	1	Bearing	28	CS235006	2	Plug - BSPP Ports
13	CH536104	1	Shaft		R515245-2	2	Plug - NPT Ports
14	★ B1012564	1	Back-Up Washer	30	DA5579026	1	Decal VM4 (not shown)
15	★ B1007503	1	O-Ring	31	B1051057	1	Pin
16	CH542950SR	1	Disc Assembly				

★ Indicates parts included in complete Pump Repair Kit, see Table 2 on page 12.

### Pump Manifolds

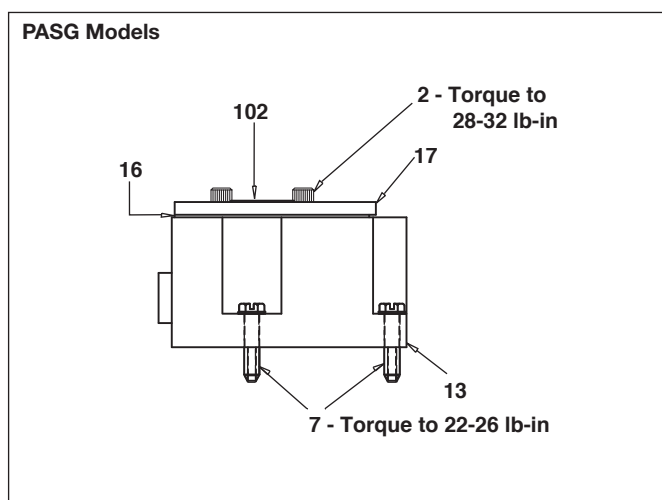

Figure 10, Pump Manifolds, PAS Version

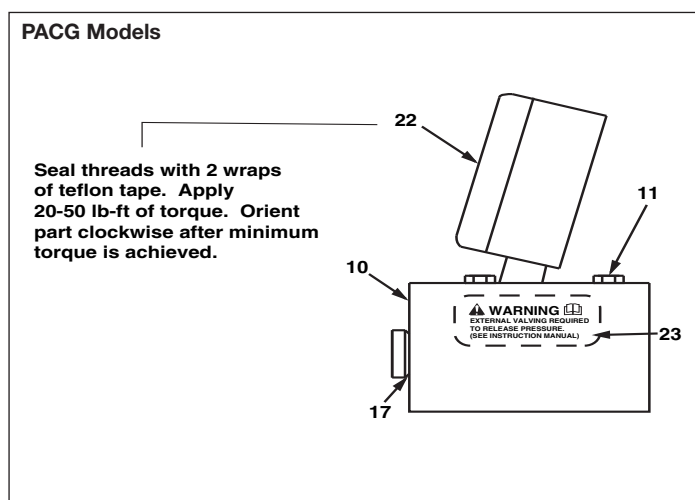

Figure 11, Pump Manifold, PAC Version

### Repair Parts List for Figure 10

Item	Part Number	Qty.	Description	Item	Part Number	Qty.	Description
2	B1321028	4	SCHS SAE Manifolds	13	DA9259840SR	1	Manifold BSPP
	CBA515028-1A	4	SHCS BSPP Manifolds	16	★ DA9787037	1	Gasket
7	DC1523028	4	Screw	17	DA9788098	1	Cover
13	DC94840SR	1	Manifold SAE	102	DA9884026	1	Warning Decal

### Repair Parts List for Figure 11

Item	Part Number	Qty.	Description	Item	Part Number	Qty.	Description
10	DA5307190	1	Valve Body - SAE Ports	22	G2517L	1	2.5" Gauge 0-6000 psi
	DA9747190	1	Valve Body - BSPP Ports		A1008245	1	Hex Plug (BSPP only)
11	DA4294028	4	Thread Forming Screw	23	DA9554026	1	Warning Decal
17	B1007503	1	O-Ring (SAE Only)				

★ Indicates parts included in and available only as part of Repair Kit. See Table 2 on page 12 for Repair Kit ordering information.

**Table 1 - Relief Valve Settings**

Pump Model	Pressure Rating	Relief Valve Pressure Setting
PA_G1_____	10,000 psi	10,400 to 11,000 psi
PA_G5_____	5,000 psi	5,200 to 5,700 psi
PA_G3_____	5,000 psi	5,200 to 5,700 psi

**For standard models with special pressure settings,** the model number will have a "dash" followed by 4 more digits to indicate the pressure setting.

To determine the pressure settings locate the model number stamp. The model number will be in the format PAYYYYYY-XXXX, where XXXX is the maximum pressure rating. The relief valve should be set from (XXXX + 250 psi to (XXXX) + 750 psi).

**Table 2 - Repair Kit Application**

Pump Model	Recommended Repair Kit
PATG1_____ PARG1_____	PATG1100K
PATG5_____ PARG5_____	PATG5100K
PATG3_____ PARG3_____	PATG3100K
PAMG1_____	PAMG1400K
PAMG5_____ PACG5_____ PASG5_____	PAMG5400K
PAMG3_____ PACG3_____ PASG3_____	PAMG3400K

**Enerpac Worldwide Locations**◆ e-mail: [info@enerpac.com](mailto:info@enerpac.com)◆ internet: [www.enerpac.com](http://www.enerpac.com)**Australia and New Zealand**

Actuant Australia Ltd.  
Block V Unit 3  
Regents Park Estate  
391 Park Road  
Regents Park NSW 2143  
(P.O. Box 261) Australia  
T +61 (0)2 9743 8988  
F +61 (0)2 9743 8648  
sales-au@enerpac.com

**Brazil**

Power Packer do Brasil Ltda.  
Rua Luiz Lawrie Reid, 548  
09930-760 - Diadema (SP) - Brazil  
T +55 11 5687 2211  
Toll Free: 0800 891 5770  
vendabrasil@enerpac.com

**China (Taicang)**

Actuant (China) Industries Co. Ltd.  
No. 6 Nanjing East Road,  
Taicang Economic Dep Zone  
Jiangsu, China  
T +86 0512 5328 7500  
F +86 0512 5335 9690  
Toll Free: +86 400 885 0369  
sales-cn@enerpac.com

**France, Switzerland, North Africa and French speaking African countries**

ENERPAC  
Une division d'ACTUANT France S.A.S.  
ZA de Courtaboeuf  
32, avenue de la Baltique  
91140 VILLEBON /YVETTE  
France  
T +33 1 60 13 68 68  
F +33 1 69 20 37 50  
sales-fr@enerpac.com

**Germany and Austria**

ENERPAC GmbH  
P.O. Box 300113  
D-40401 Düsseldorf  
Willstätterstrasse 13  
D-40549 Düsseldorf, Germany  
T +49 211 471 490  
F +49 211 471 49 28  
sales-de@enerpac.com

**India**

ENERPAC Hydraulics (India) Pvt. Ltd.  
No. 10, Bellary Road, Sadashivanagar,  
Bangalore, Karnataka 560 080  
India  
T +91 80 3928 9000  
info@enerpac.co.in  
www.enerpac.com

**Italy**

ENERPAC S.p.A.  
Via Canova 4  
20094 Corsico (Milano)  
T +39 02 4861 111  
F +39 02 4860 1288  
sales-it@enerpac.com

**Japan**

Applied Power Japan LTD KK  
Besshocho 85-7  
Kita-ku, Saitama-shi 331-0821, Japan  
T +81 48 662 4911  
F +81 48 662 4955  
sales-jp@enerpac.com

**Middle East, Egypt and Libya**

ENERPAC Middle East FZE  
Office 423, LOB 15  
P.O. Box 18004, Jebel Ali, Dubai  
United Arab Emirates  
T +971 (0)4 8872686  
F +971 (0)4 8872687  
sales-ua@enerpac.com

**Russia**

Rep. office Enerpac  
Russian Federation  
Admirala Makarova Street 8  
125212 Moscow, Russia  
T +7 495 98090 91  
F +7 495 98090 92  
sales-ru@enerpac.com

**Southeast Asia, Hong Kong and Taiwan**

Actuant Asia Pte Ltd.  
83 Joo Koon Circle  
Singapore 629109  
T +65 68 63 0611  
F +65 64 84 5669  
Toll Free: +1800 363 7722  
sales-sg@enerpac.com

**South Korea**

Actuant Korea Ltd.  
3Ba 717, Shihwa Industrial Complex  
Jungwang-Dong, Shihung-Shi,  
Kyunggi-Do  
Republic of Korea 429-450  
T +82 31 434 4506  
F +82 31 434 4507  
sales-kr@enerpac.com

**Spain and Portugal**

ENERPAC SPAIN, S.L.  
Avda. Los Frailes, 40 - Nave C & D  
Pol. Ind. Los Frailes  
28814 Daganzo de Arriba  
(Madrid) Spain  
T +34 91 884 86 06  
F +34 91 884 86 11  
sales-es@enerpac.com

**Sweden, Denmark, Norway, Finland and Iceland**

Enerpac Scandinavia AB  
Kopparlundsvägen 14,  
721 30 Västerås  
Sweden  
T +46 (0) 771 41 50 00  
scandinavianinquiries@enerpac.com

**The Netherlands, Belgium, Luxembourg, Central and Eastern Europe, Baltic States, Greece, Turkey and CIS countries**

ENERPAC B.V.  
Galvanistraat 115, 6716 AE Ede  
P.O. Box 8097, 6710 AB Ede  
The Netherlands  
T +31 318 535 911  
F +31 318 535 848  
sales-nl@enerpac.com

**Enerpac Integrated Solutions B.V.**

Opaalstraat 44, 7554 TS Hengelo  
P.O. Box 421, 7550 AK Hengelo  
The Netherlands  
T +31 74 242 20 45  
F +31 74 243 03 38  
integratedsolutions@enerpac.com

**South Africa and other English speaking African countries**

Enerpac Africa Pty Ltd.  
No. 5 Bauhinia Avenue  
Cambridge Office Park  
Block E  
Highveld Techno Park  
Centurion 0157  
Republic of South Africa  
T: +27 12 940 0656  
sales-za@enerpac.com

**United Kingdom and Ireland**

ENERPAC UK Ltd.  
5 Coopies Field  
Morpeth, Northumberland  
NE61 6JR, England  
T +44 (0) 1670 5016 50  
F +44 (0) 1670 5016 51  
sales-uk@enerpac.com

**USA, Latin America and Caribbean**

ENERPAC World Headquarters  
P.O. Box 3241  
Milwaukee WI 53201-3241 USA  
N86 W12500 Westbrook Crossing  
Menomonee Falls, Wisconsin 53051  
T +1 262 293 1600  
F +1 262 293 7036  
User inquiries:  
T +1 800 433 2766  
Distributor inquiries/orders:  
T +1 800 558 0530  
F +1 800 628 0490  
Technical inquiries:  
techservices@enerpac.com  
sales-us@enerpac.com

All Enerpac products are guaranteed against defects in workmanship and materials for as long as you own them.

For the location of your nearest authorized Enerpac Service Center, visit us at [www.enerpac.com](http://www.enerpac.com)

011415