



Draw IT 2016 for AutoCAD

Tutorial for System Scaffolding



Contents

Introduction	1
Getting Started.....	2
1 Getting Started with AutoCAD	3
1.1 Step 1: Placing the Elevation, Side and Plan Views.....	4
1.1.1 Step 1a: Getting Started.....	5
1.1.2 Step 1b: Locating the Cuplok Tool Palette	6
1.1.3 Step 1c: Placing the Scaffold Views onto the Drawing	7
1.2 Step 2: Entering the Scaffold Dimensions.....	10
1.2.1 Step 2a: Setting the Number of Lifts.....	11
1.2.2 Step 2b: Setting the Number of Bays.....	12
1.2.3 Step 2c: Defining the Guard Rails and Boards	13
1.3 Step 3: Adding the Facade Bracing	15
1.4 Step 4: Drawing the Ladders and Boards.....	18
1.4.1 Step 4a: Adding Ladders to the Elevation, Side and Plan Views.....	18
1.4.2 Step 4b: Adding the Boards to the Plan View	22
1.5 Step 5: Drawing a Gable End.....	25
1.6 Step 6: Annotating the Drawing.....	29
1.6.1 Step 6a: Adding Dimensions	29
1.6.2 Step 6b: Adding Stamps	32
1.6.3 Step 6c: Title Block	33
1.7 Step 7: Drawing an Irregular Scaffold	35
1.7.1 Step 7a: Exploding the Scaffold into Components.....	35
1.7.2 Step 7b: Adding Double Guardrail Frames.....	36
1.7.3 Step 7c: Adding a Bridge	38
Feedback.....	40

Getting Started



Please read the SMART Scaffolder **Draw IT 2016** user manual before you start. All of the AutoCAD commands used in this Tutorial are described in the User Guide.

You can start the application by either double-clicking the icon on your desktop, or by selecting the application from Start → All Programs → CADs.

In Windows 8 or Windows 8.1, you can alternatively select the **Draw IT** Windows 8 tile.

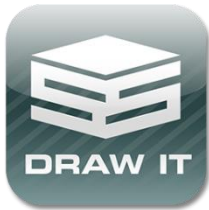

Draw IT (AutoCAD 2016)

AutoCAD will then open with **Draw IT 2016** automatically loaded.



If you start AutoCAD using the **Draw IT** icon then your scaffolding tools will be ready to use. Only start AutoCAD with the AutoCAD icon when you don't want to use **Draw IT**.

1 Getting Started with AutoCAD



This tutorial has been written for Cuplok system scaffolding, but you can follow the same steps to draw scaffolding with any other system that you have installed.

This tutorial explains how to create a Cuplok system scaffold using AutoCAD. SMART Scaffolder **Draw IT** allows you to easily draw system scaffolding in two ways:

1. You can use *dynamic* scaffolds to very quickly draw regular scaffolding;
2. The individual components of the Cuplok catalogue are provided. These can be dragged and dropped onto the drawing to build any shape of scaffolding.

This tutorial demonstrates how to use a dynamic scaffold to quickly build a regular scaffold with a gable end, including its plan and elevation views. It will also show how to use the drag and drop components, which will enable you to build more complicated scaffolds using the same techniques.

The steps involved are:

1. Drag-and-drop the dynamic elevation view, side view and plan view onto the drawing;
2. Enter the dimensions of the scaffold;
3. Add facade bracing;
4. Draw the ladders and boards;
5. Add a gable end;
6. Annotate the drawing with text and dimensions;
7. 'Explode' the scaffold to draw advanced features such as a bridge.

The tutorial concludes by demonstrating how to modify the scaffold to build an irregular shape or to account for special circumstances.

1.1 Step 1: Placing the Elevation, Side and Plan Views

This step will demonstrate:

1. Starting SMART Scaffolder **Draw IT 2016**;
2. Finding the Cuplok tool palette;
3. Dragging and dropping the dynamic Cuplok system scaffolding blocks onto the drawing.

Once these steps have been completed the drawing will appear as follows:

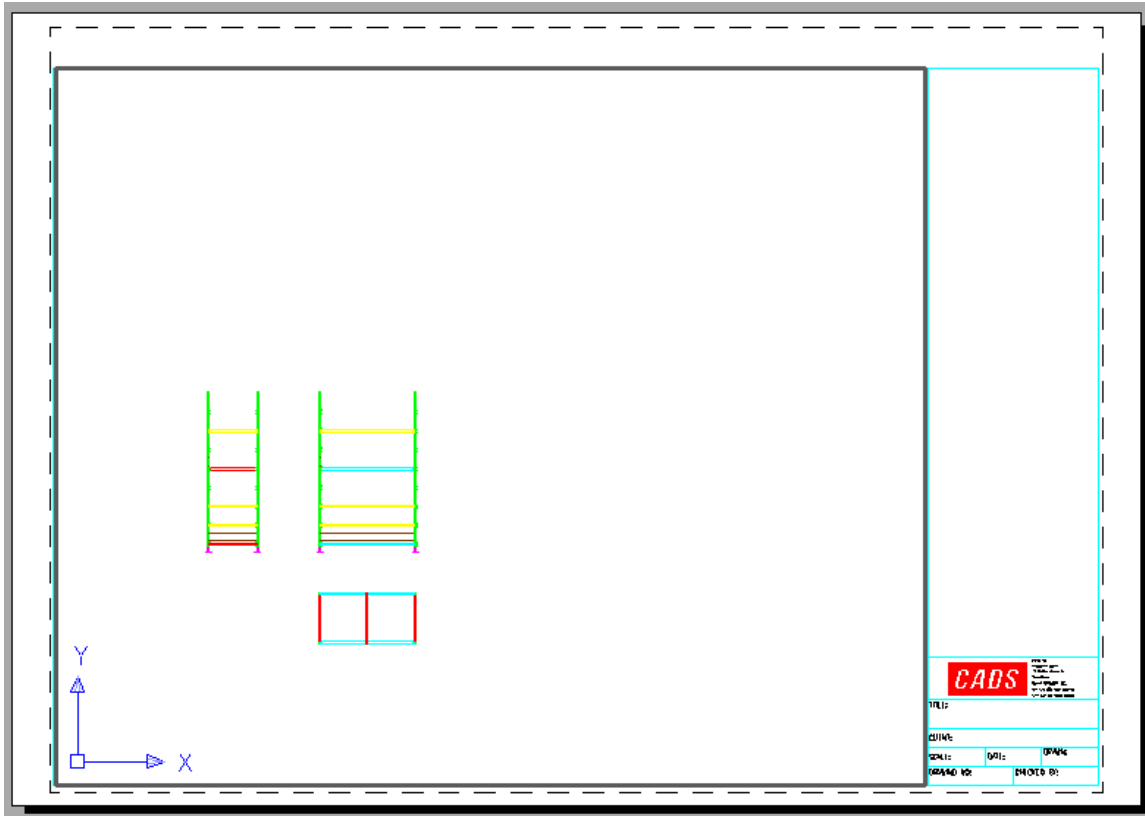

1.1.1 Step 1a: Getting Started

To get started:

1. Double click the **Draw IT** icon on the Windows Desktop.
2. Select the A2 paper size using the **Quick View Layouts** option.

To choose the layout that you want to use in AutoCAD 2009 / 2010, click the **Quick View Layouts** button at the very bottom of the AutoCAD window:

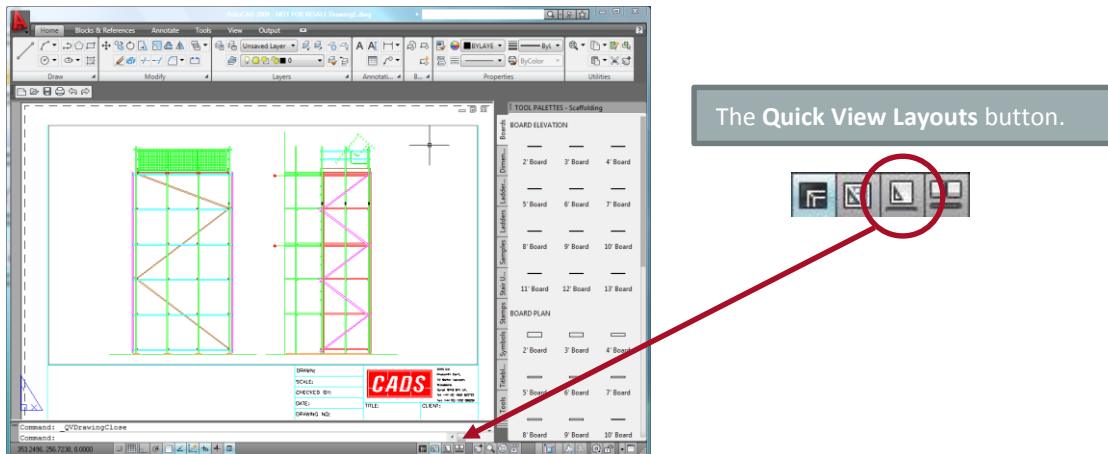

You can then click on the paper size that you require:

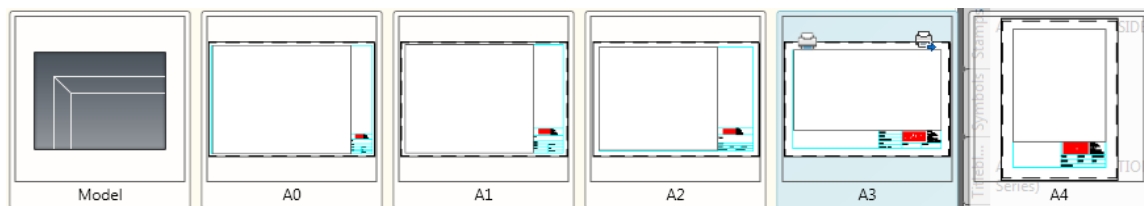

The other versions of AutoCAD use tabs along the bottom of the screen to perform the same function.

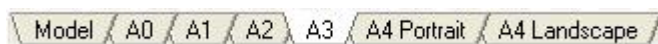

3. Once the A2 layout is visible, double-click in the centre of the paper to activate the **viewport**. This is the area that you will be drawing into.

1.1.2 Step 1b: Locating the Cuplok Tool Palette

The AutoCAD *tool palette* allows you to drag and drop scaffolding components onto the drawing. The palette contains a number of tabbed pages, which can be clicked to display different types of scaffolding components. For example there are tabbed pages for Cuplok dynamic components, tabbed pages that provide the catalogue of Cuplok components, and tabbed pages for tube-and-fitting components.

The tool palette should be visible in the AutoCAD window, as shown below.



If the **Tool Palette** is not visible, click the **View** toolbar tab and then click on the **Tool Palette** icon on the **Palettes** panel.

To activate the Cuplok components, click on the tab with the title: **Cuplok Scaffold System**. If this tab is not visible, click on the stacked tabs at the bottom of the tool palette to see the complete list:

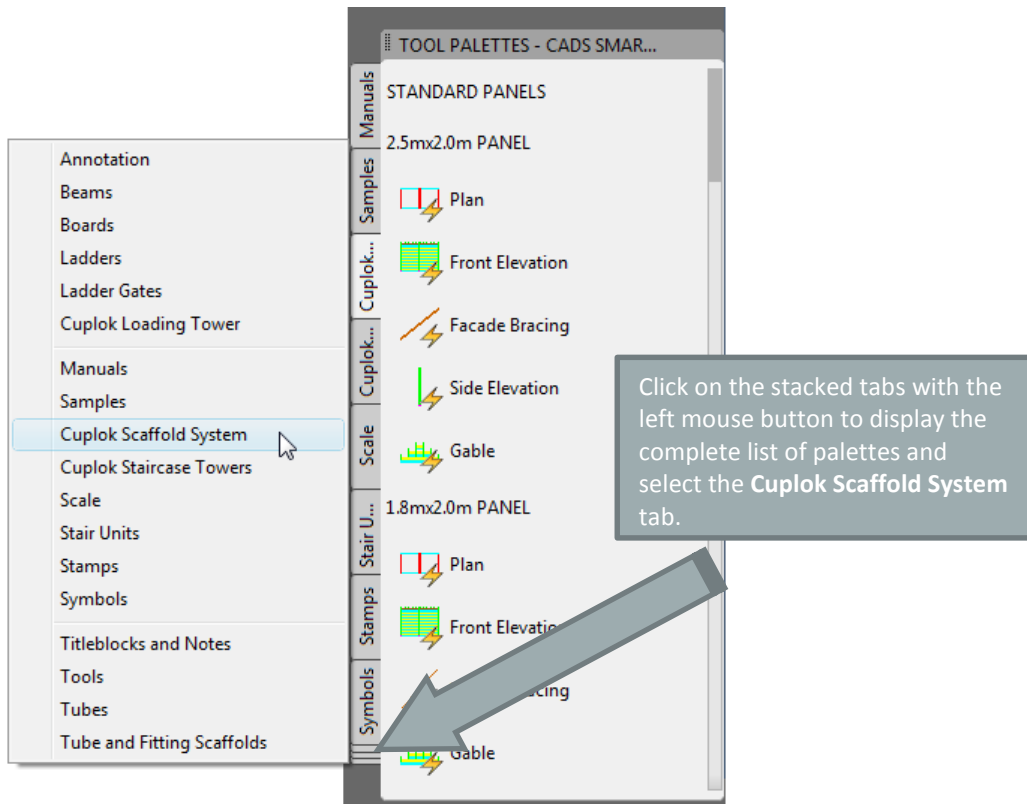

1.1.3 Step 1c: Placing the Scaffold Views onto the Drawing

1. Locate the **Cuplok Scaffold System** tab on the tool palette as described previously;
2. To place the scaffold plan, click on the **Plan** icon in the palette;
3. Move across to the drawing and click to position the scaffold plan on the drawing;
4. When placing the scaffold plan allow enough room for the side elevation to be drawn to the left, as shown below.



Make sure you double click inside the Viewport to activate it before you try to drag and drop the scaffold plan.

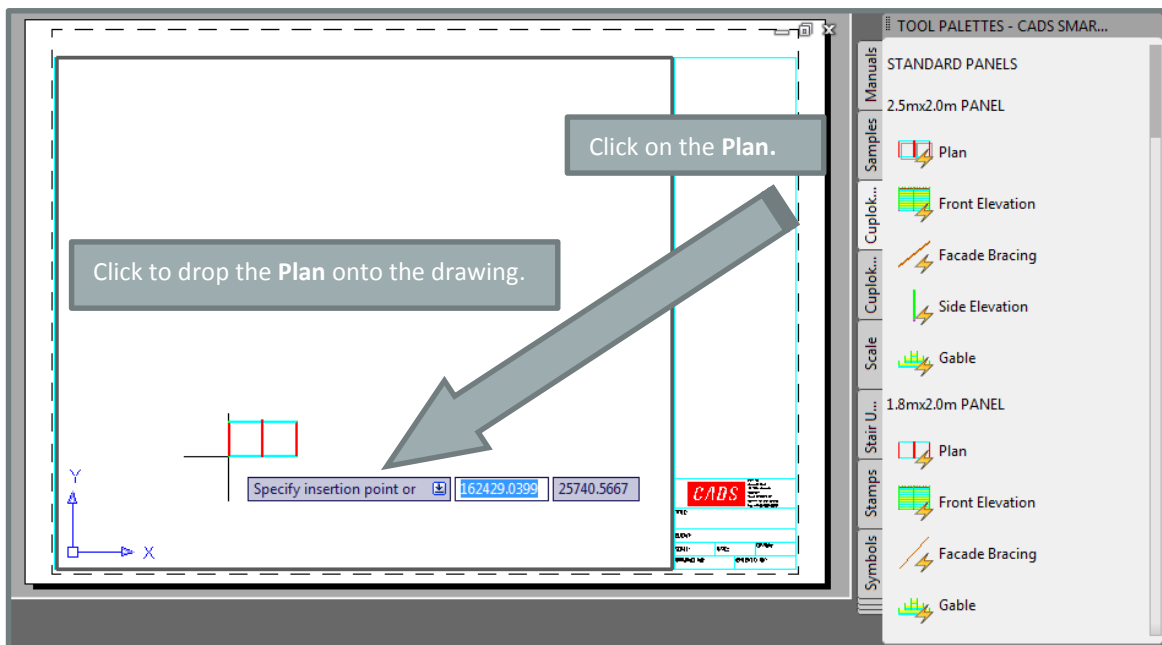

- The next step is to place the front elevation onto the drawing so that it is aligned with the plan view. This will be achieved by using an AutoCAD feature known as **inference**.



If you prefer you can use **construction lines** to place the front and side elevations instead, as described in the *Tube and Fitting Tutorial*.

It helps to zoom in by moving the mouse cursor over the plan view that you have just placed and rolling the mouse wheel forward.

Click on the **Front Elevation** tool from the **Cuplok Scaffold System palette**, move the mouse over the first transom in the plan view, and hover it there for a second. Now move the mouse upward and you will see a dotted line that is aligned with the transom position; if you click the mouse on the dotted line the elevation and plan views will be aligned.

First click on the **Front Elevation** tool...

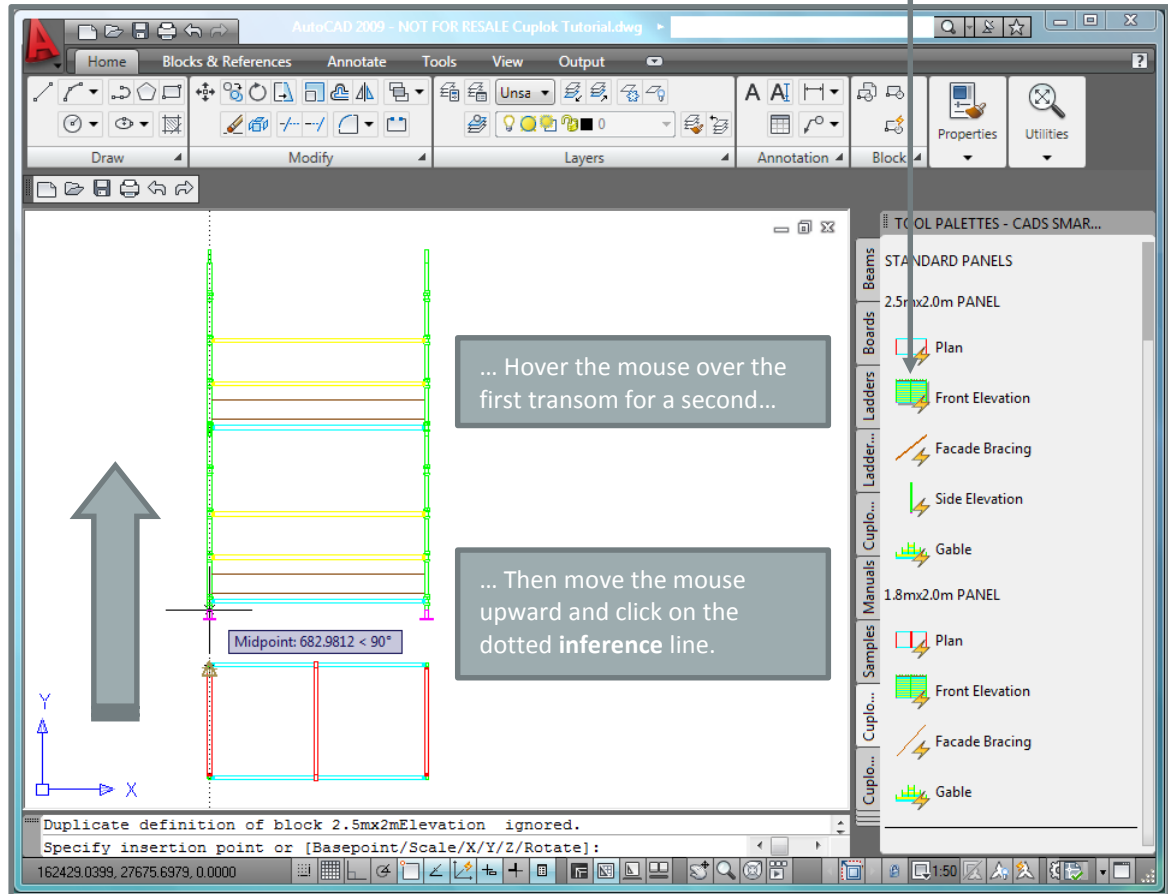

... Hover the mouse over the first transom for a second...

... Then move the mouse upward and click on the dotted inference line.

- The **Side Elevation** is placed in a similar way, this time by using a horizontal inference line that starts from the front elevation drawing.

It helps to first **pan** the view to clear some space: hold the mouse wheel down, move the mouse to the right, then release the mouse wheel.

Click on the **Side Elevation** tool from the **Cuplok Scaffold System palette**, move the mouse over the first base plate in the front elevation view, and hover it there for a second. Now move the mouse to the left to create a horizontal inference line and click on it to place the side elevation.

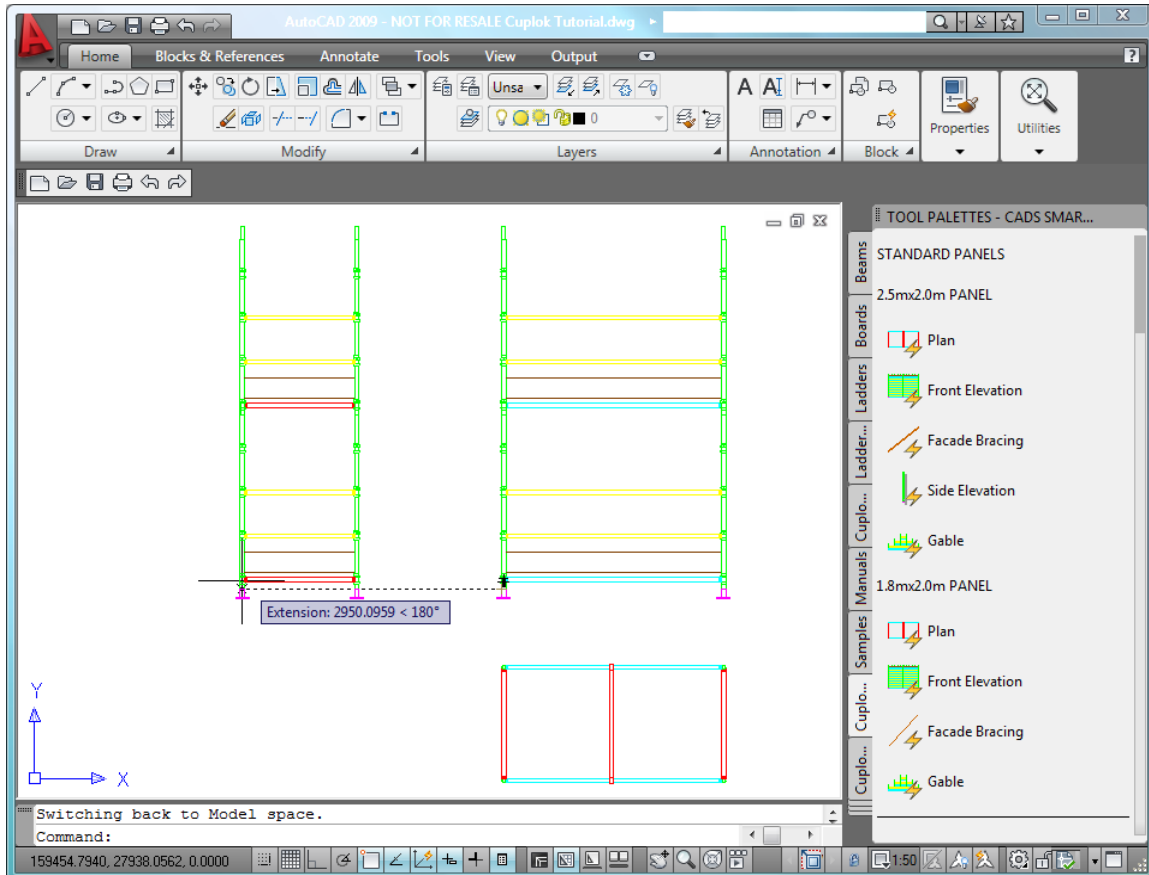

This completes placing the scaffold plan, front elevation, and side elevation.

1.2 Step 2: Entering the Scaffold Dimensions

This step will demonstrate how to:

1. Change the number of lifts and bays in the scaffold.
2. Change the board and guard rail details.

The views of the scaffold placed in **Step 1** are AutoCAD *dynamic blocks*. A dynamic block has intelligence built into it that allows it to be changed as you work. The **Draw IT** scaffold dynamic blocks allow you to change the dimensions of the scaffold using **grips**.

To activate the grips for a dynamic block, click on it so that it becomes selected. To deactivate the grips press the **Esc** key to clear the selection.

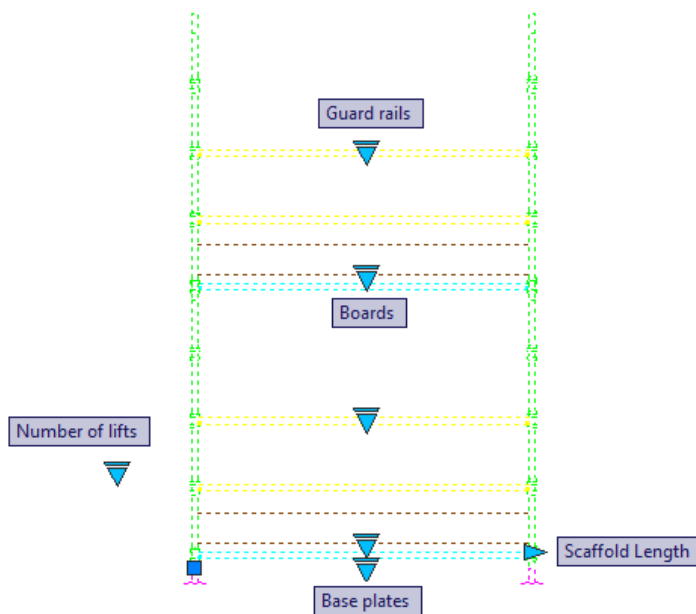

Some of the dynamic blocks have additional parameters that are only accessible via the properties palette.



If the AutoCAD Properties Palette is not visible, click the **View** toolbar tab and then click on the **Properties** icon on the **Palettes** panel.

1.2.1 Step 2a: Setting the Number of Lifts

1. Click on the front elevation of the scaffold to activate it.
2. Click on the **Number of Lifts** grip, shown in the previous diagram, and select **3 Lifts**.

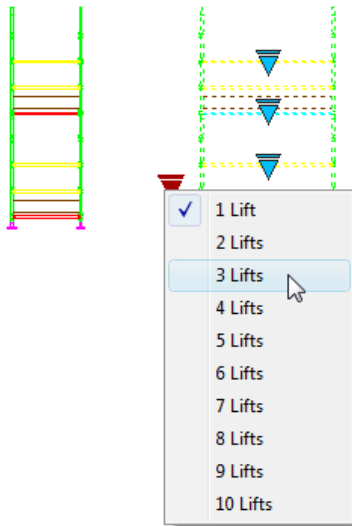

3. Now click on the side view of the scaffold to activate it and set its number of lifts to 3 in the same way.

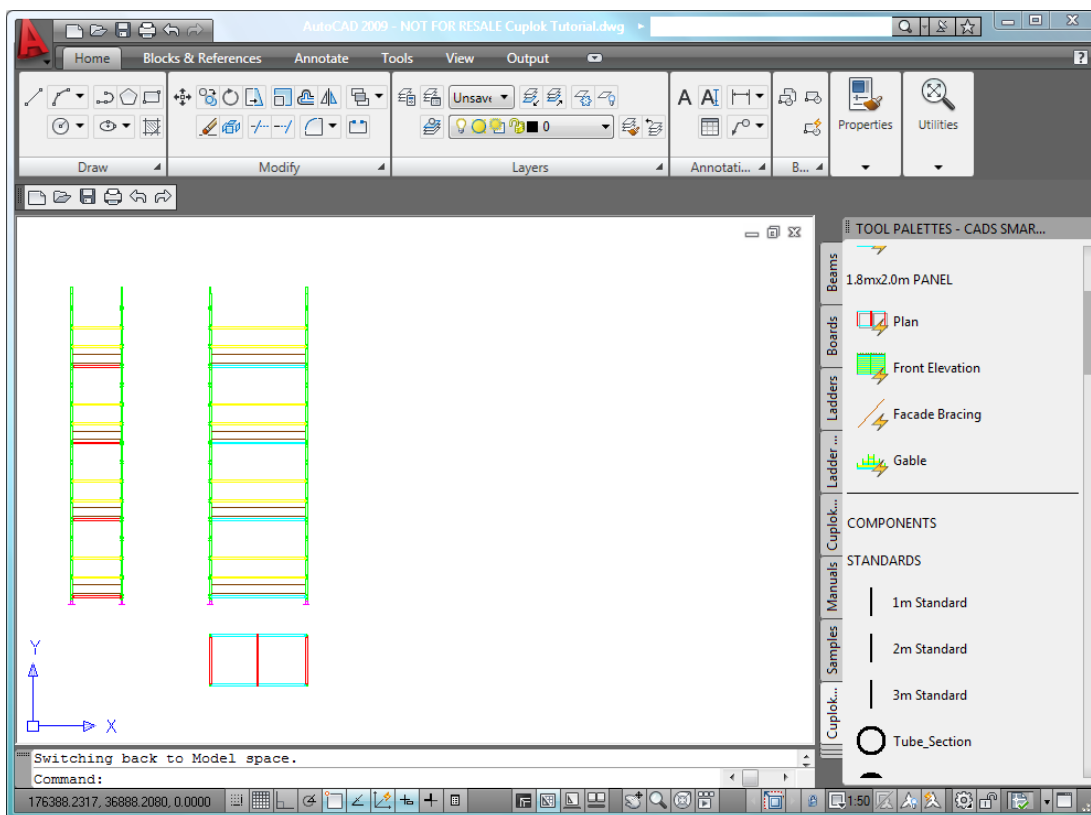

1.2.2 Step 2b: Setting the Number of Bays

The next step is to set the number of bays of scaffolding. At this stage regular bays of 2.5m will be used.

1. Click on the front elevation of the scaffold to activate it.
2. Click on the **Scaffold Length** grip and move it to the right. You will see a marker at each bay position: click the left mouse button once the scaffold is 15000mm long, when the mouse cursor is at the sixth marker:

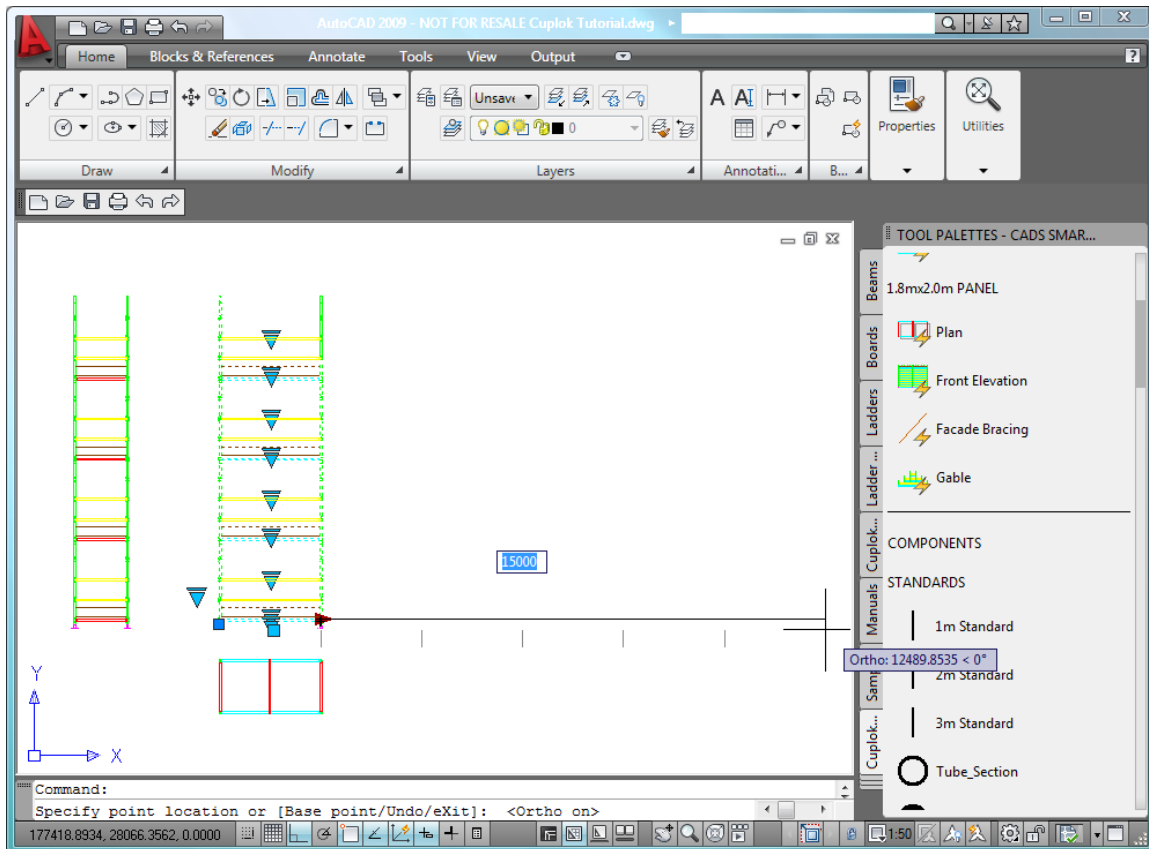

3. Repeat this process for the plan view by clicking on it to activate it, clicking on its **Scaffold Length** grip, and clicking the mouse past the sixth marker.

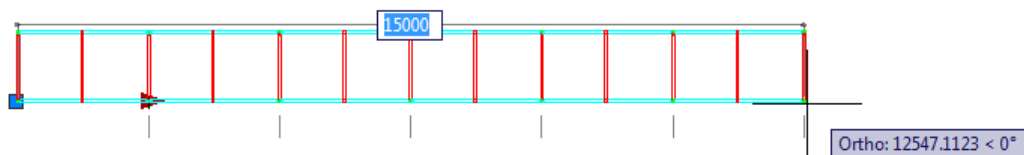

1.2.3 Step 2c: Defining the Guard Rails and Boards

The next stage is to define which lifts are to be boarded and how many guard rails to place at each lift. The scaffold will have every lift boarded, including the foot lift, and protected by double guard rails by default, but this can be changed by using the grips in a similar way to the entry of the lifts and bays.

1. Click on the front elevation to activate it.
2. Click on the **Guard Rails** grip at the foot lift and choose **None**; the guard rails and boards will be removed.

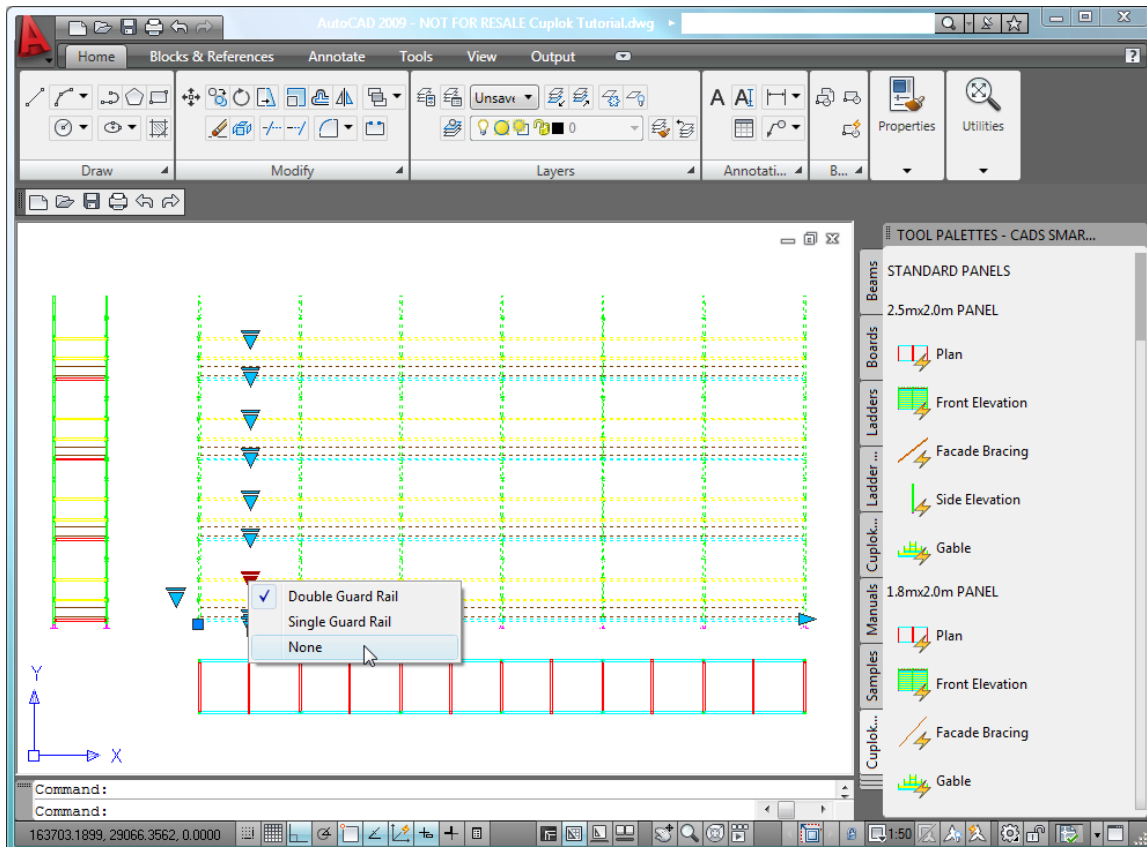

3. Next, click on the **Guard Rails** grips at the first and second lifts and select **Single Guard Rail**.



The boards are switched off by default when the guard rails are removed or set to single rails.

However, you can switch them back on again by using the **Boards** grip if you wish, for example if drawing a birdcage scaffold.

4. Click on the side view to activate it and repeat the process by clicking on its **Guard Rails** grips.
5. Press the **Esc** key to clear the selection when you have finished.

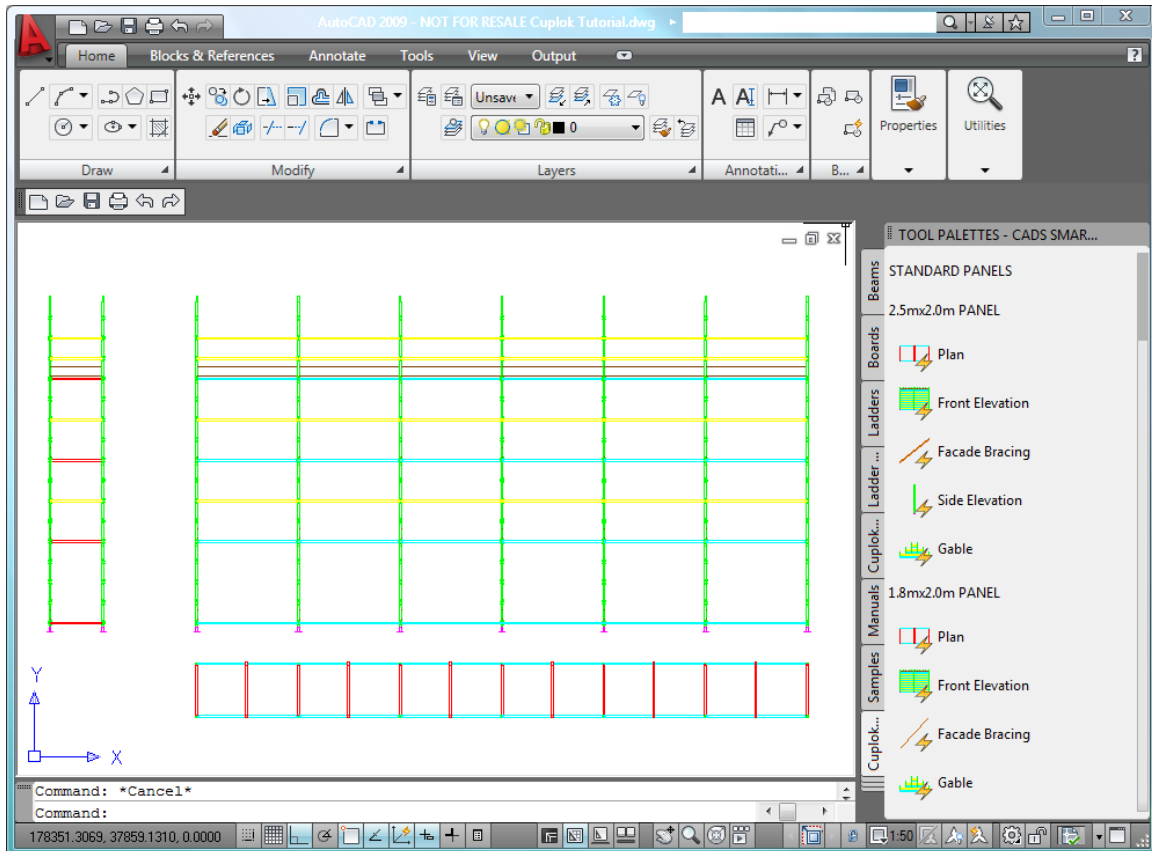

Advanced guard rail options, for example using guard rail frames instead of horizontals, will be demonstrated later in this tutorial.

1.3 Step 3: Adding the Facade Bracing

Facade bracing can be drawn by dragging and dropping the **Facade Bracing** tool from the tool palette onto the front elevation.

1. Press the **Esc** key to clear the selection.
2. Click on the **Facade Bracing** tool from the tool palette and move the mouse over the drawing area.
3. Click on the intersection between the first standard and the foot lift on the front elevation to place the bracing.

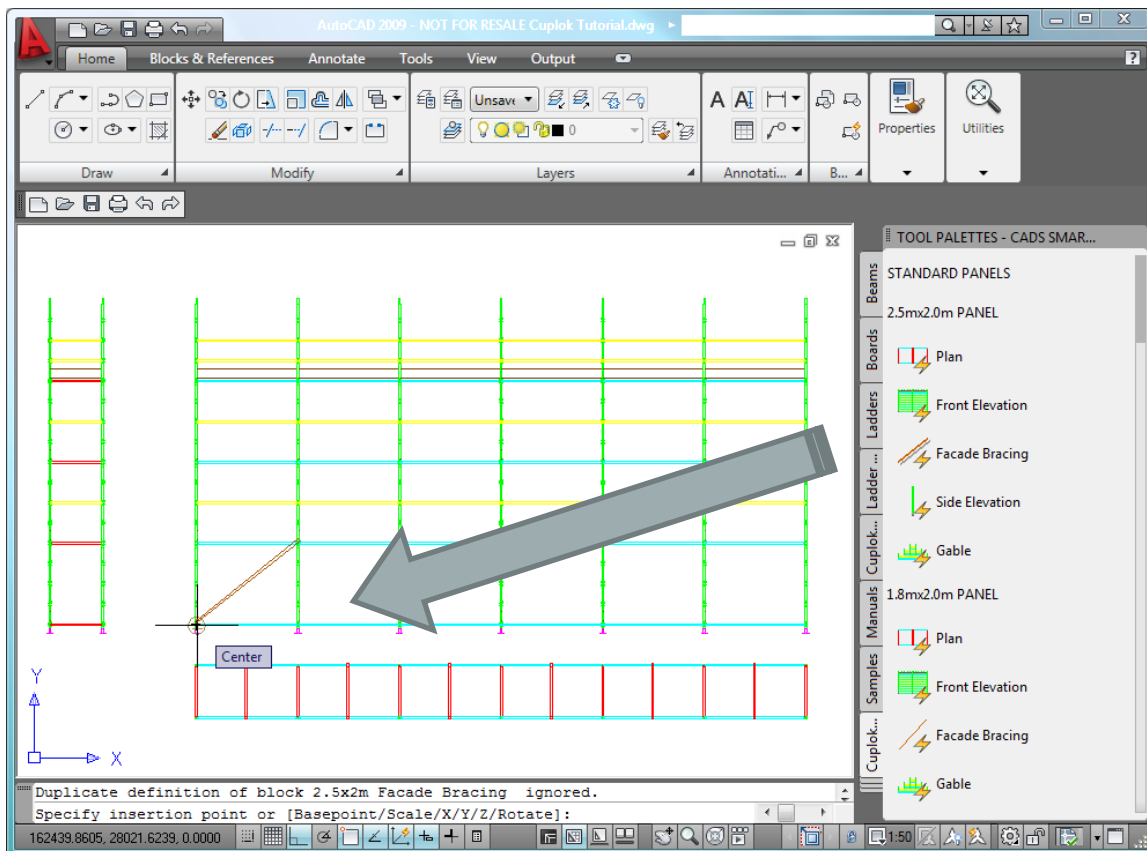

4. Repeat the process by dragging and dropping another set of facade bracing onto the final bay, clicking on the intersection between the sixth standard and the foot lift.

Now that both sets of bracing have been placed they can be stretched up to the top lift.

- Click on the first set of facade bracing so that it is selected and its grips appear:

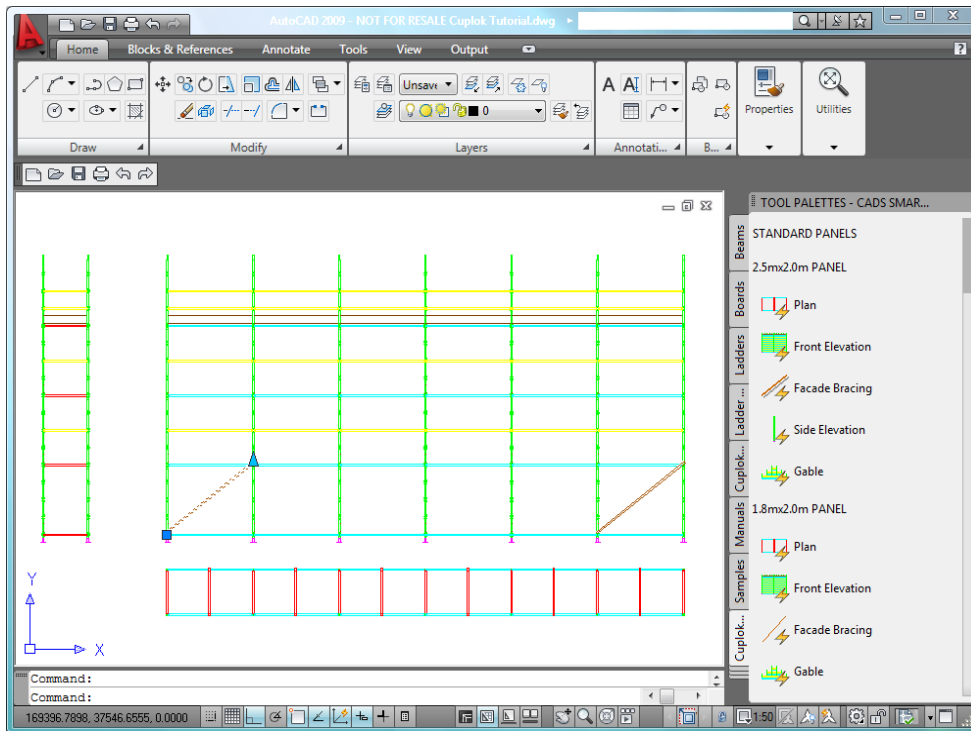

- Click on the arrow grip, move the mouse up to the top lift, and click on the left mouse button to place it.

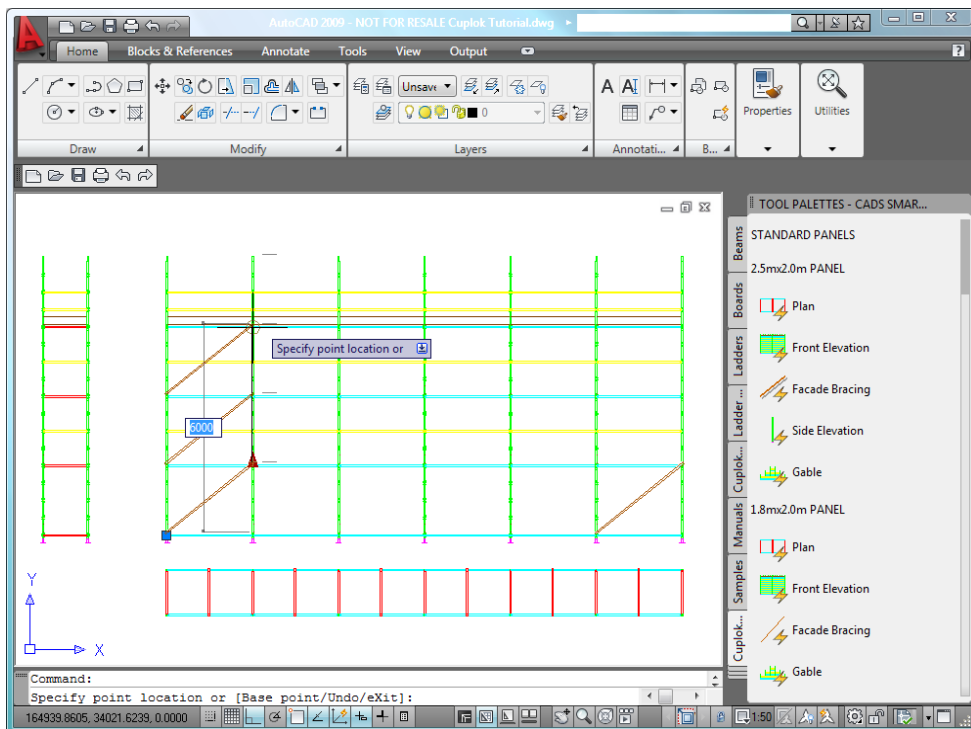

- Press the **Esc** key to clear the selection.

- Repeat the process for the second set of bracing by selecting it, clicking on its arrow grip, and stretching it to the top lift.

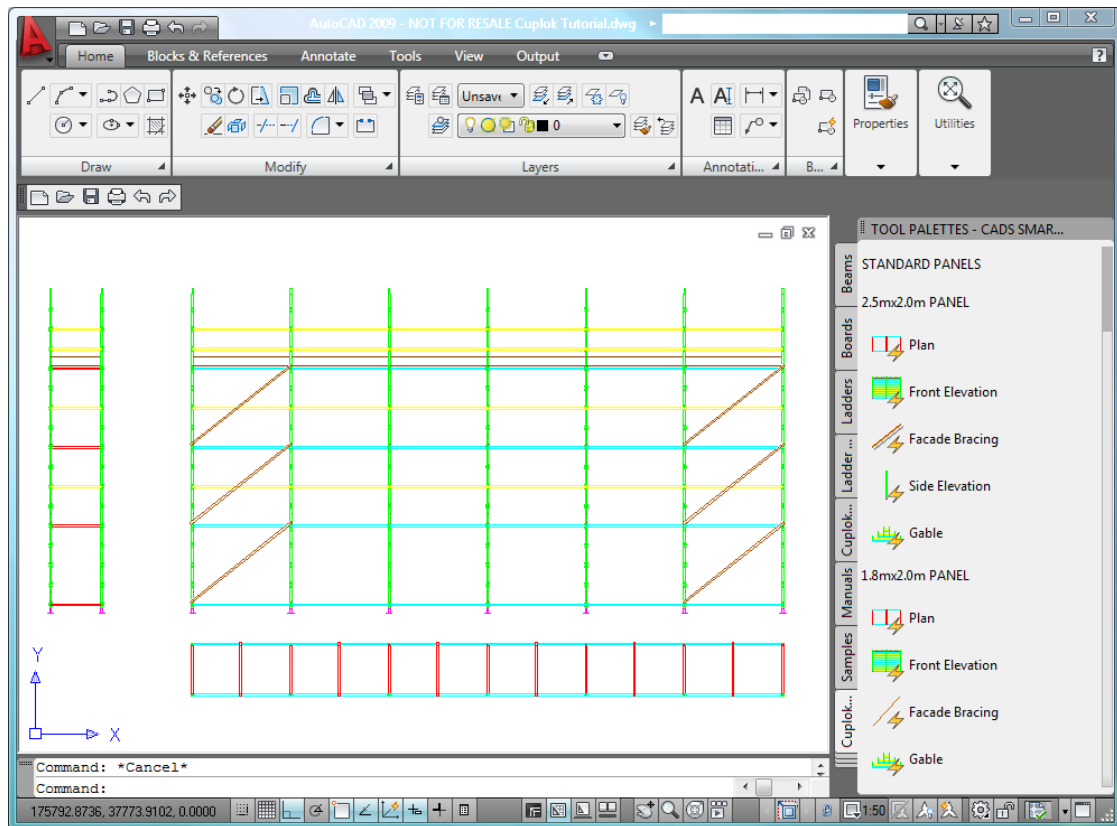

This completes the placement of the facade bracing.

1.4 Step 4: Drawing the Ladders and Boards

The next stage is to add a ladder and draw the boards.

1.4.1 Step 4a: Adding Ladders to the Elevation, Side and Plan Views

Ladders can be dragged and dropped on to the drawing from the AutoCAD tool palette:

1. Change to the **Ladders Tab** on the tool palette.
2. Next choose the **26' Ladder** tool from the **Ladder Side View** section and drop it onto the far right of the scaffold elevation.



You may wish to split this ladder into two or three shorter ladders by using intermediate boarded landings, but for this tutorial we will use a single ladder for brevity.

This tutorial also assumes that standard ladders will be used rather than integrated ladder platforms, although ladder platforms can be drawn in a similar way.

Click on the **26' Ladder** in the **Ladder Side View** section and drop on the far right of the scaffold elevation.

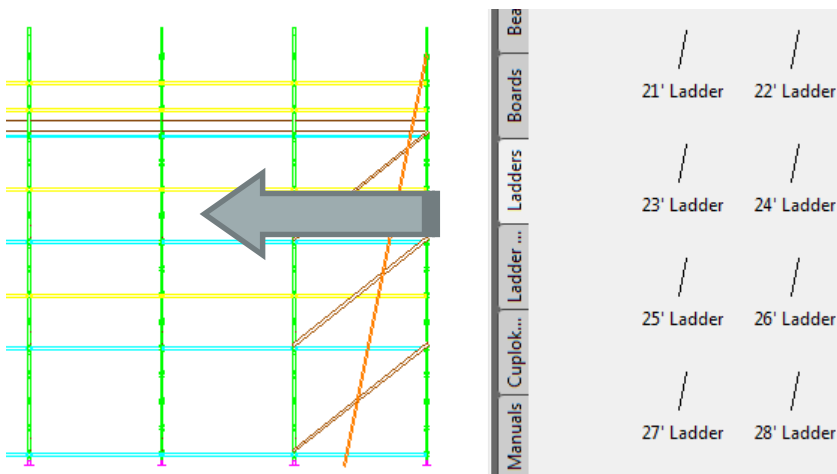

3. The ladder will be drawn in front of the scaffold by default. Press the **Esc** key to clear the selection, click on the ladder to select it, and click the right mouse button to display the AutoCAD context menu. Choose **Draw Order** → **Send to Back** to move the ladder behind the scaffold.

- Next choose the **26' Ladder** tool from the **Ladder Front Elevation** section and drop it onto the far right of the side view of the scaffold.

You may find it helpful to zoom in and use an **inference** line to place the bottom of the ladder in line with the bottom of the foot lift.

Once the ladder has been placed, use the **Draw Order** → **Send to Back** option to place the ladder behind the scaffold in the same manner as the elevation view.

Click on the **26' Ladder** in the **Ladder Front Elevation** section and drop it on the far right of the side view.

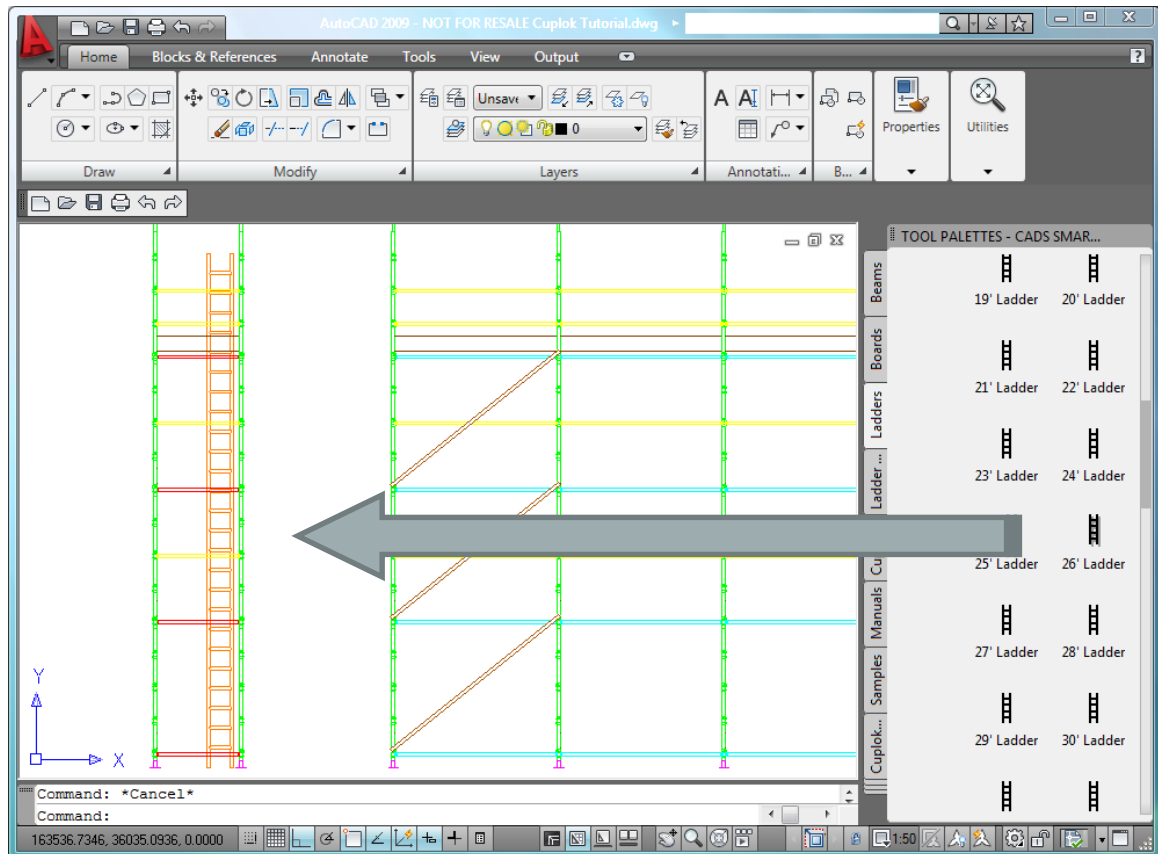

- Finally a ladder will be added to the plan view. A short ladder will be placed to represent the projected view of the ladder on plan: drop a **3' Ladder** from the **Ladder Front Elevation** section onto the final transom of the plan view of the scaffold.

Click on the **3' Ladder** and drop onto the far right transom of the scaffold plan view.

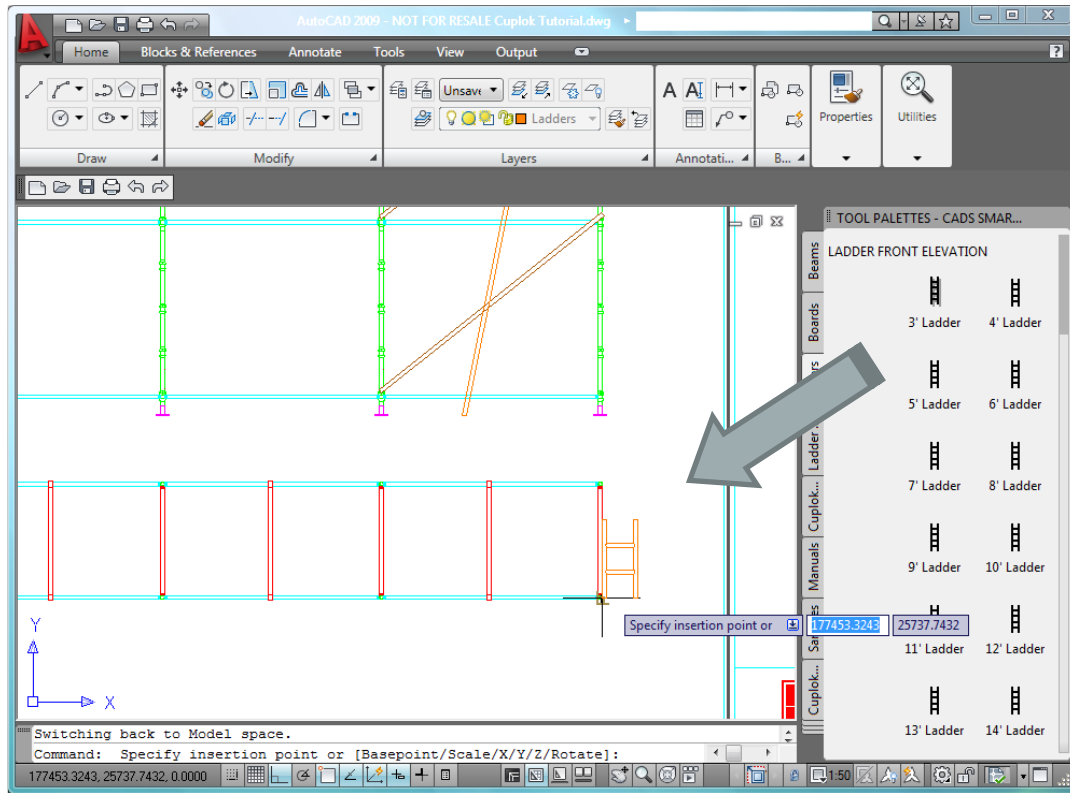

- To rotate the ladder into position, click on the ladder to activate it, and click on the **grip** in the lower right corner with the left mouse button. Then click on the grip with the right mouse button to display the **grip menu**:

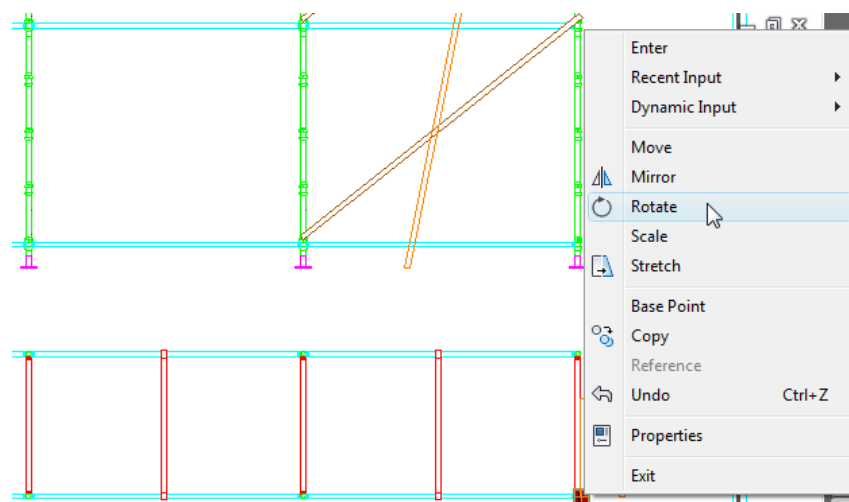

- Choose the **Rotate** option, move the mouse vertically up the screen to rotate the ladder into the horizontal position, and click the left mouse button to place it:

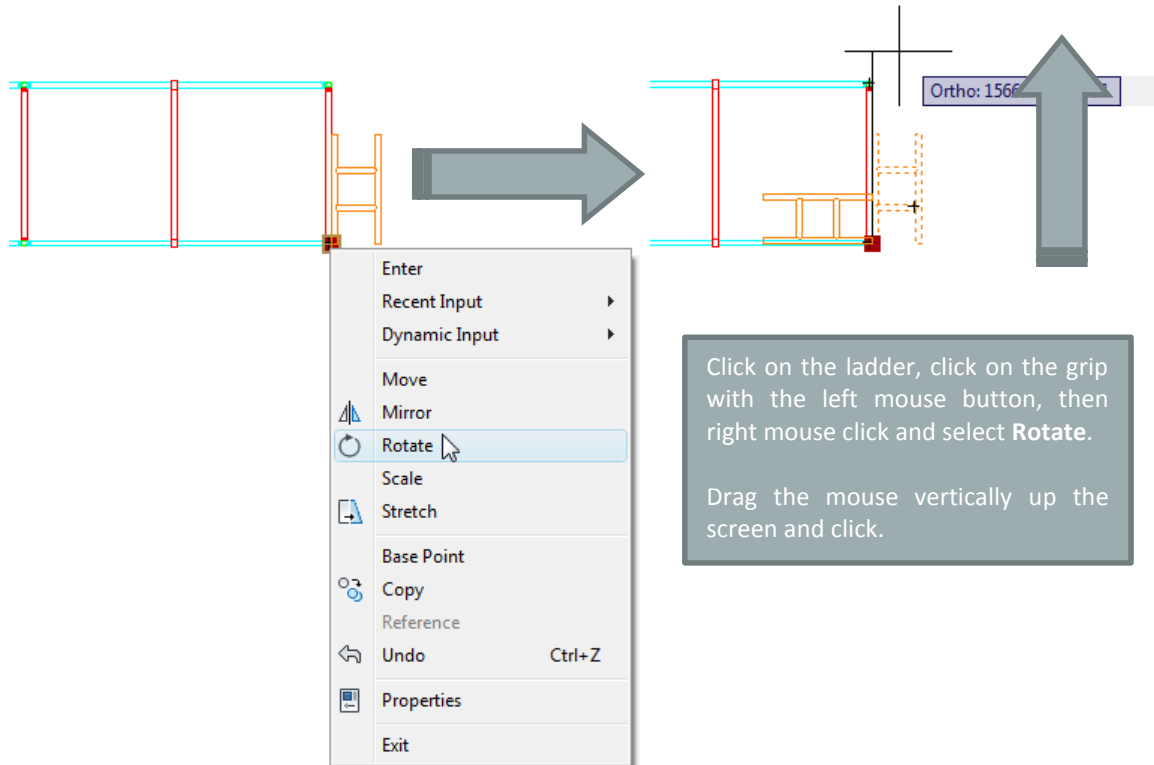

You need to click on the grip with the left mouse button before clicking the right mouse button to display the menu in order to use the **grip rotate** option.

If you just press the right mouse button you use the normal **rotate** option, which is more complicated to use.

This completes the placement of the ladders.

1.4.2 Step 4b: Adding the Boards to the Plan View

Boards can be dragged and dropped on to the drawing from the AutoCAD tool palette. SMART Scaffolder **Draw IT 2016** offers boards and toe boards in elevation, plan and section.

The toe boards and main boards will be drawn by dragging and dropping board components onto the plan view of the scaffold.

1. Switch to the **Boards** tab on the tool palette.
2. The toe boards will be drawn first. Choose the **13' Board** tool from the **Board Elevation** section of the tool palette and drop it onto the bottom-left corner of the scaffold plan.

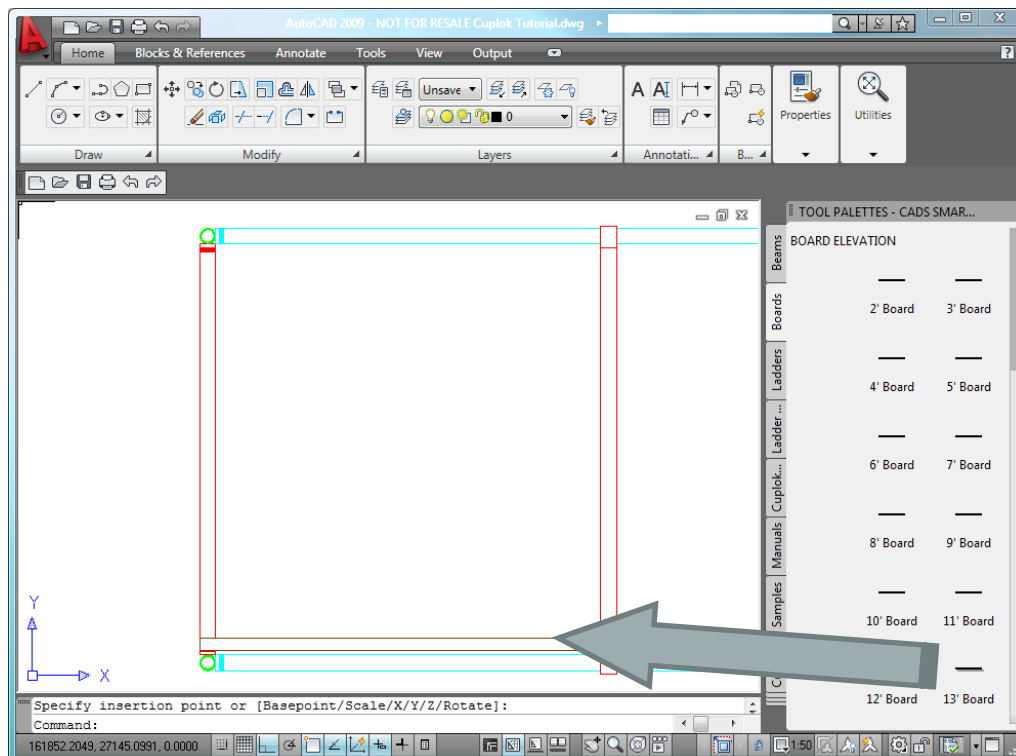

- Now select the **13' Board** tool from the **Board Plan** section of the tool palette and drop it above the toe board to create the first main board. Repeat this four more times to place all five main boards:

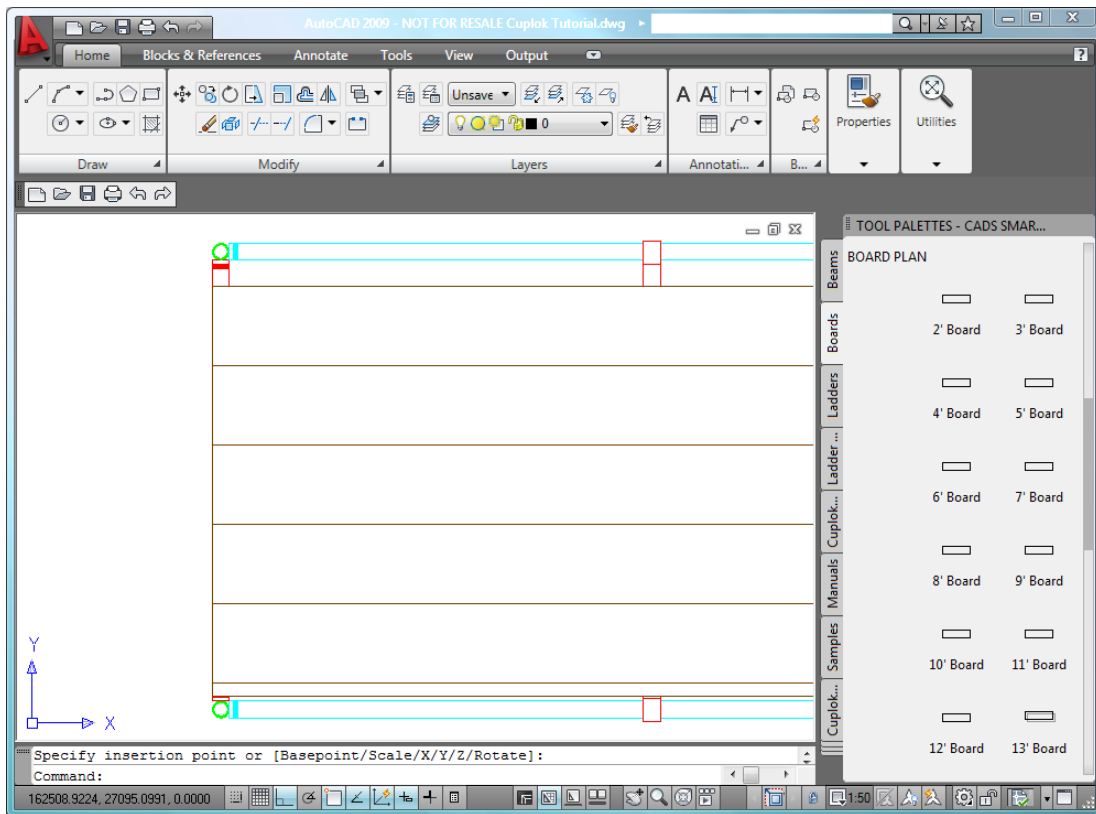

- The next stage is to copy these boards across the length of the scaffold. Press the **Esc** key, to ensure that no other components are selected, and select all six boards, including the toe board, by clicking them with the mouse:

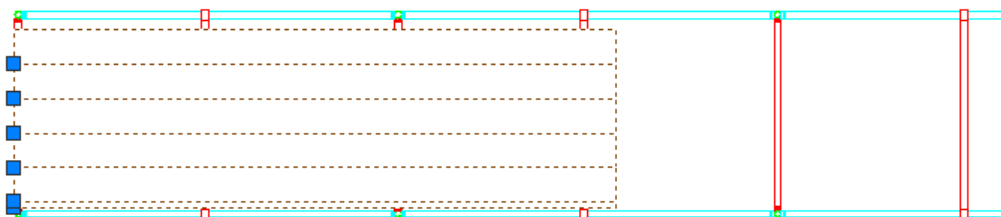

- Copy the six boards and paste them to the right of the first set:

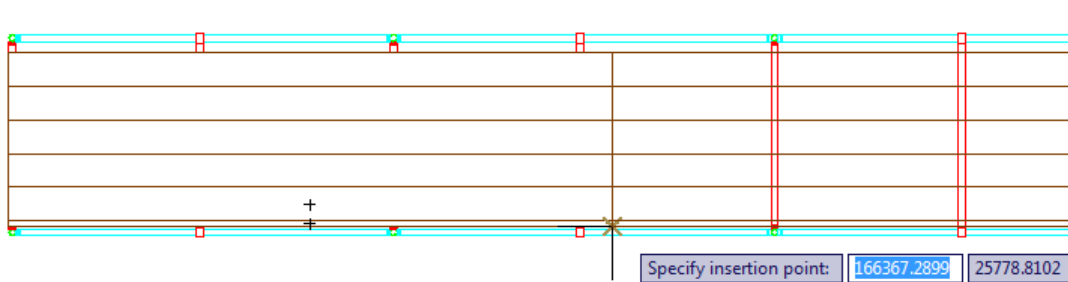

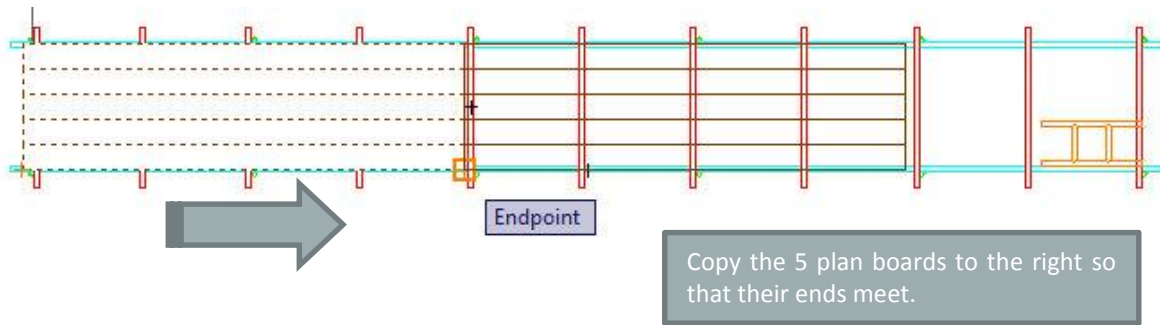

6. Paste the boards again and place them to the right of the second set:

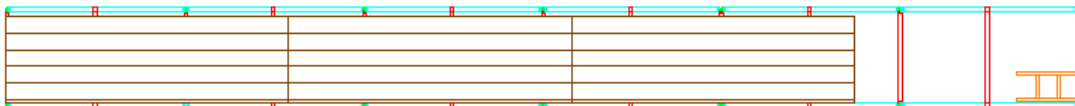

7. Boards will now be built around the ladder. Drag and drop an **11' Board** from the **Board Elevation** section to build the toe board, followed by two **8' Boards** and three **11' Boards** from the **Board Plan** section of the tool palette.

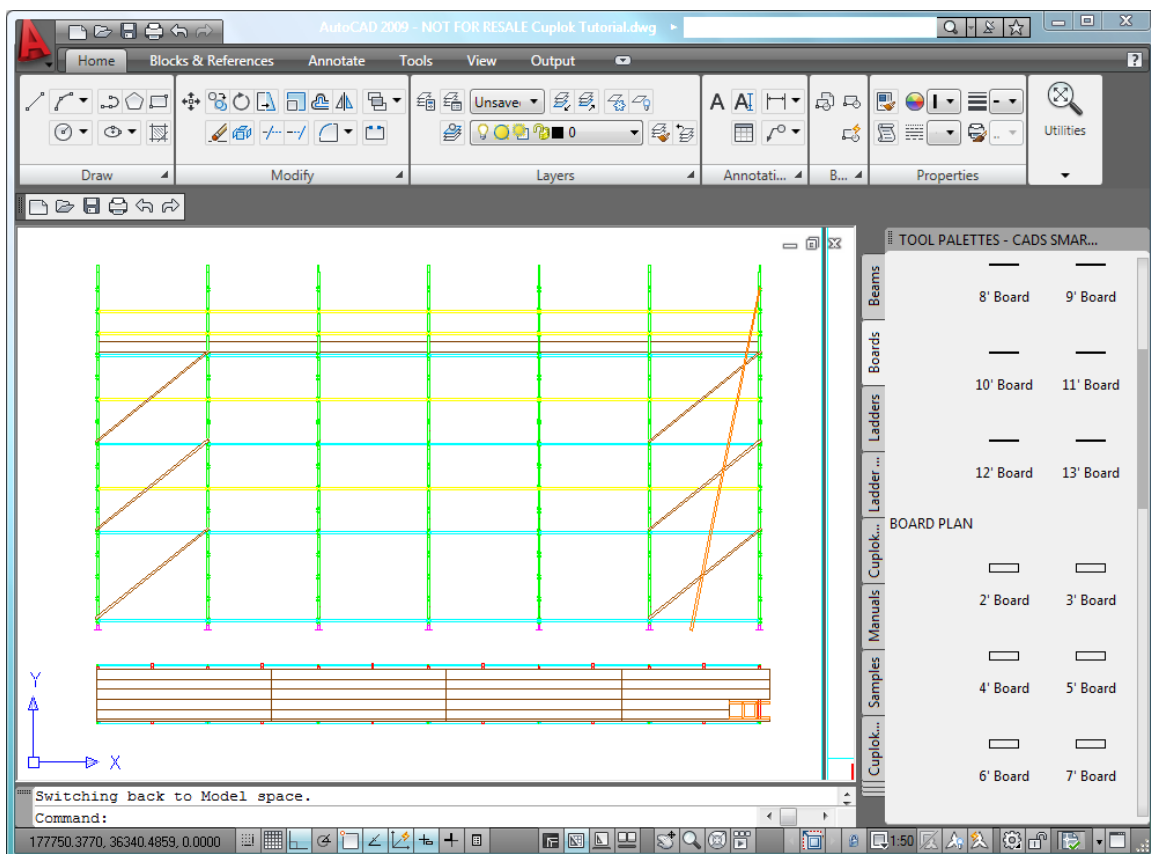

This completes the placement of the boards.

1.5 Step 5: Drawing a Gable End

Several dynamic blocks can be added together to create a more complex scaffold. In this example a gable end is going to be placed on top of the existing drawing.

1. Change to the **Cuplok Scaffold System** tab on the tool palette.
2. Click on the **Gable** tool and place it on the midpoint of the top of the third standard of the scaffold front elevation.

It is helpful to zoom in to make it easier to select the midpoint of the standard:

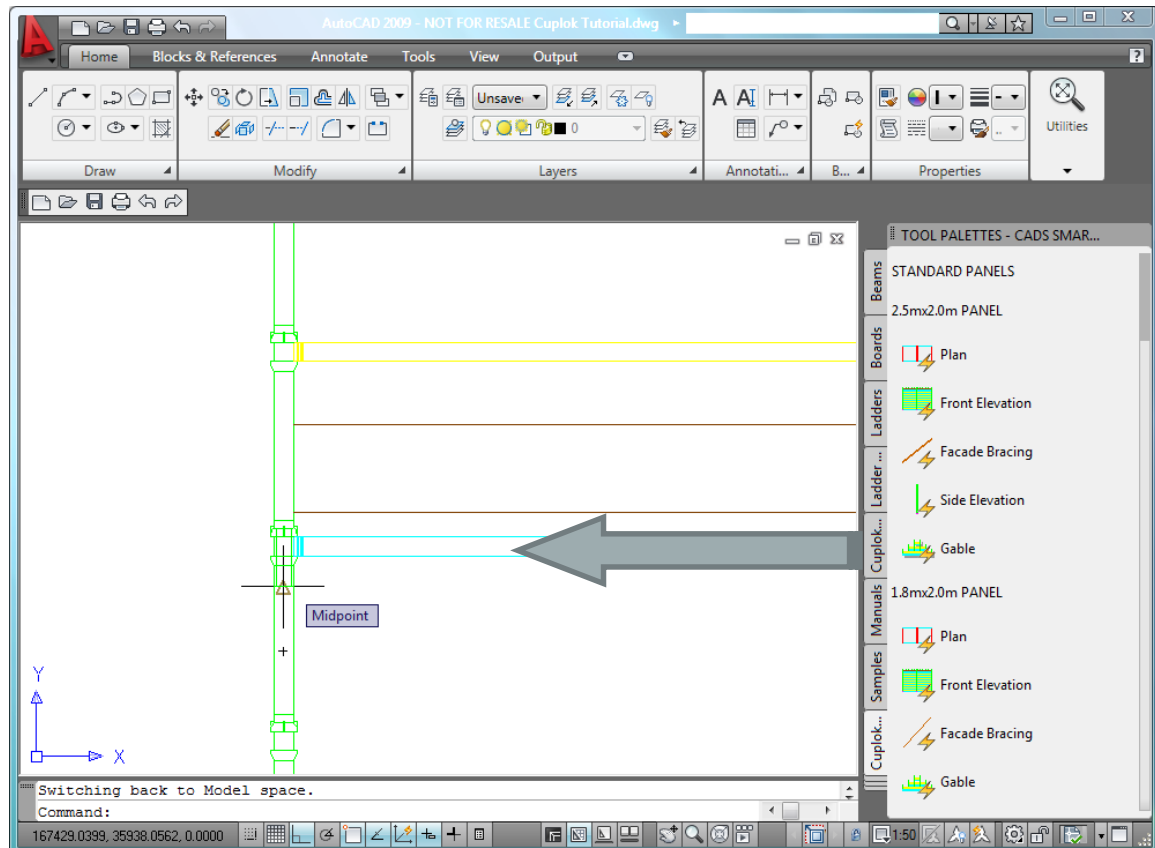

Zoom out again so that the whole scaffold is visible.

- The next step is to define the width of the gable end and set the number of lifts.

Click on the gable end so that it is selected and its grips are visible. Click on the **Number of Lifts** grip and select **2 Lifts**:

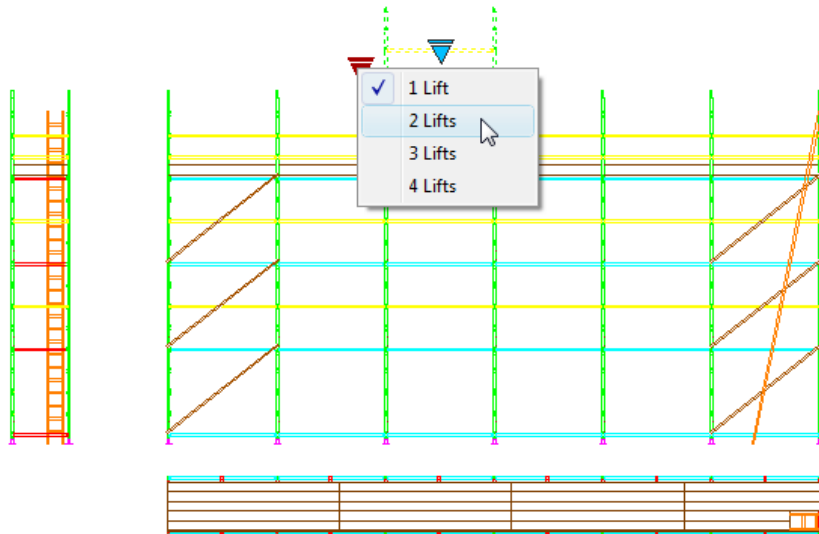

- The lengths of the gable lifts can be modified by clicking on the left and right arrow grips at each lift position. Click on the left arrow grip of the first gable lift, move the mouse left by one bay, and click to create a new gable bay:

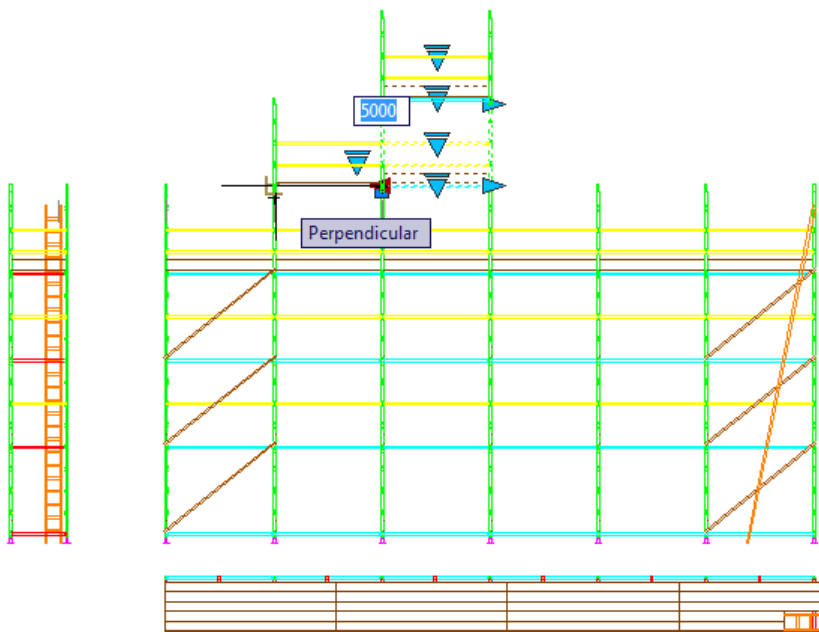

- Repeat this operation for the right-hand grip of the first gable lift, stretching the lift by two bays so that it becomes symmetrical:

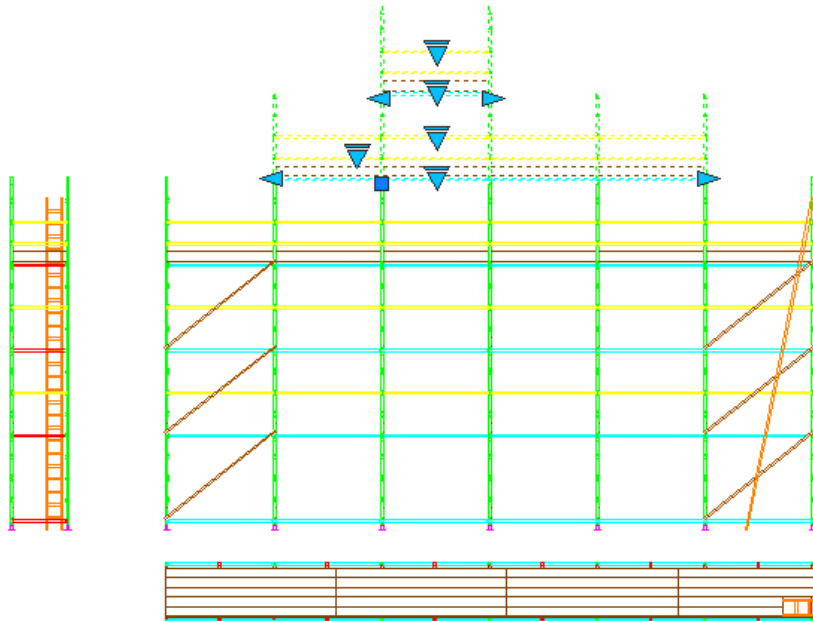

- Then stretch the right arrow grip of the second gable lift by one bay and press the **Esc** key to clear the selection.

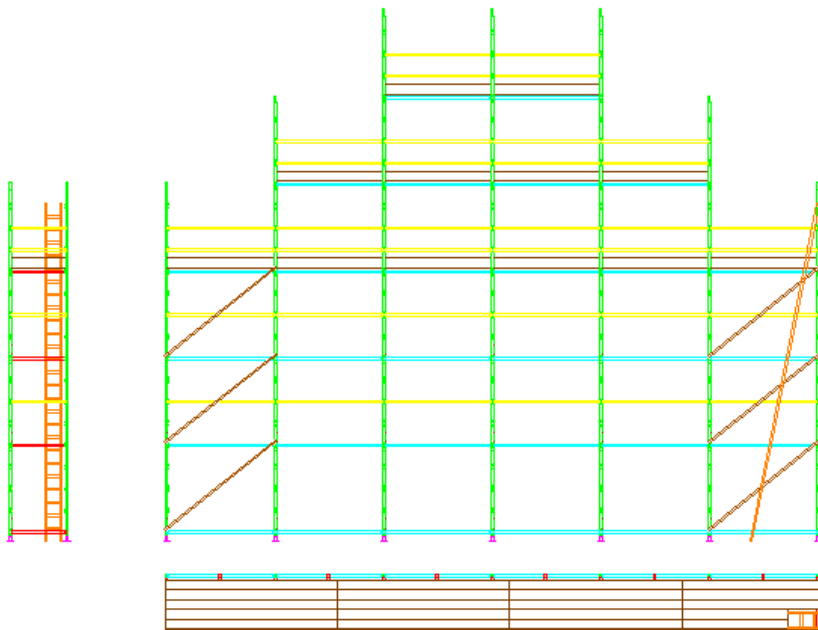

- The gable end can be completed by adding some facade bracing and a ladder in the same manner described previously. A **17' Ladder** can be used this time:

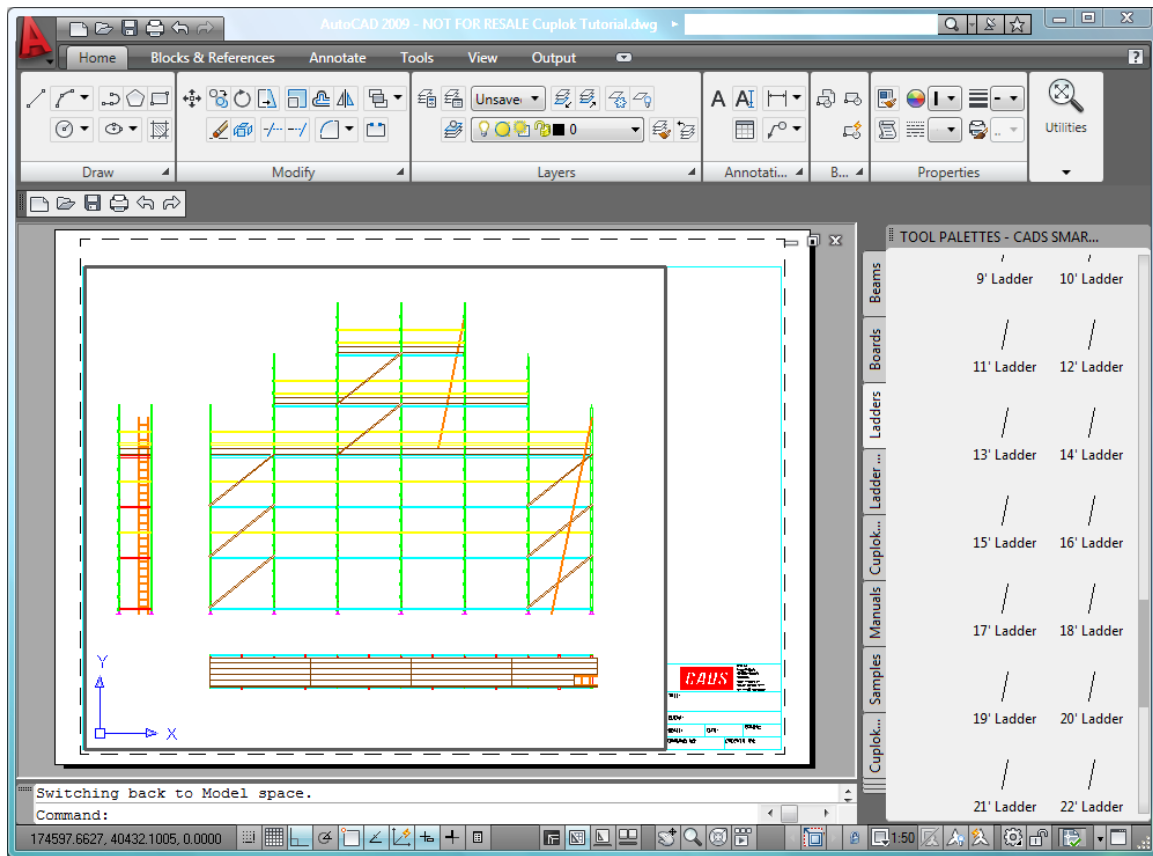

This completes the placement of the gable end.

1.6 Step 6: Annotating the Drawing

This step of the tutorial will demonstrate how to annotate the drawing by adding dimensions and title information.

1.6.1 Step 6a: Adding Dimensions

SMART Scaffolder **Draw IT 2016** is automatically set up to print dimensions correctly at any scale; all you need to do is add them to the drawing.

1. Set the AutoCAD layer to **Dims** before placing the dimensions.

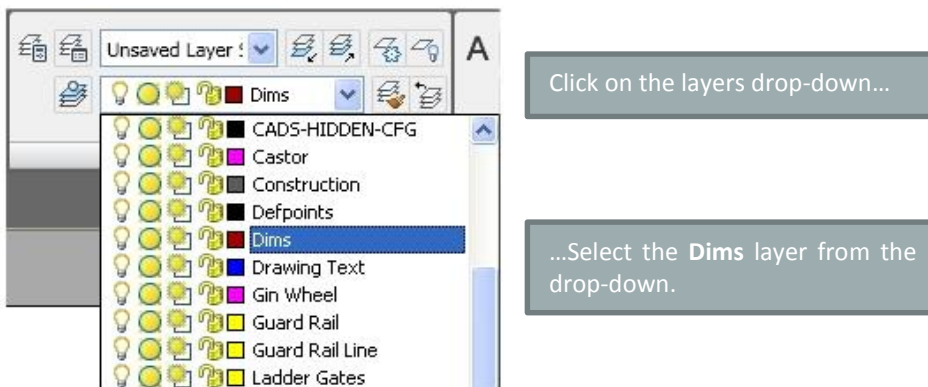

2. Select the **Annotate** toolbar to access the **Dimension** commands.

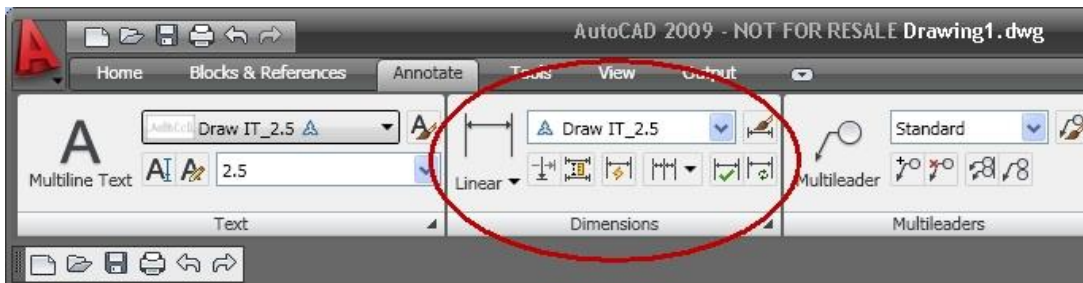

Dimensions can be placed with different text heights on the drawing, SMART Scaffolder **Draw IT 2016** is supplied with three different styles. The most commonly used style draws the text at 2.5mm high; this style is called **Draw IT_2.5** and is the default style.

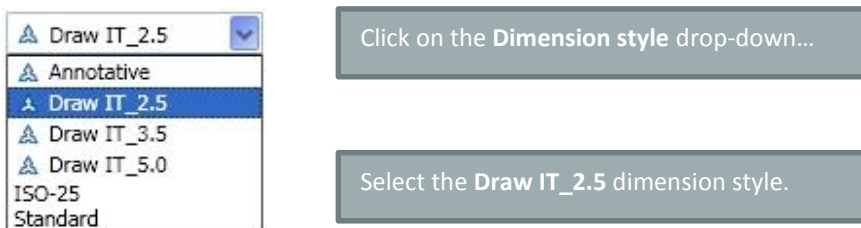

3. Click on the **Linear** dimension command to begin placing the first dimension.
4. Zoom in so that the first standard, the foot lift, and the first lift are clearly visible on the drawing. Click on the bottom-left corner of the top cup at the foot lift to place the first point of the dimension, then click on the bottom-left corner of the top cup at the first lift.

The dimension line will then be created. Move the mouse to the left and click the left mouse button to place the dimension to the left of the scaffold:

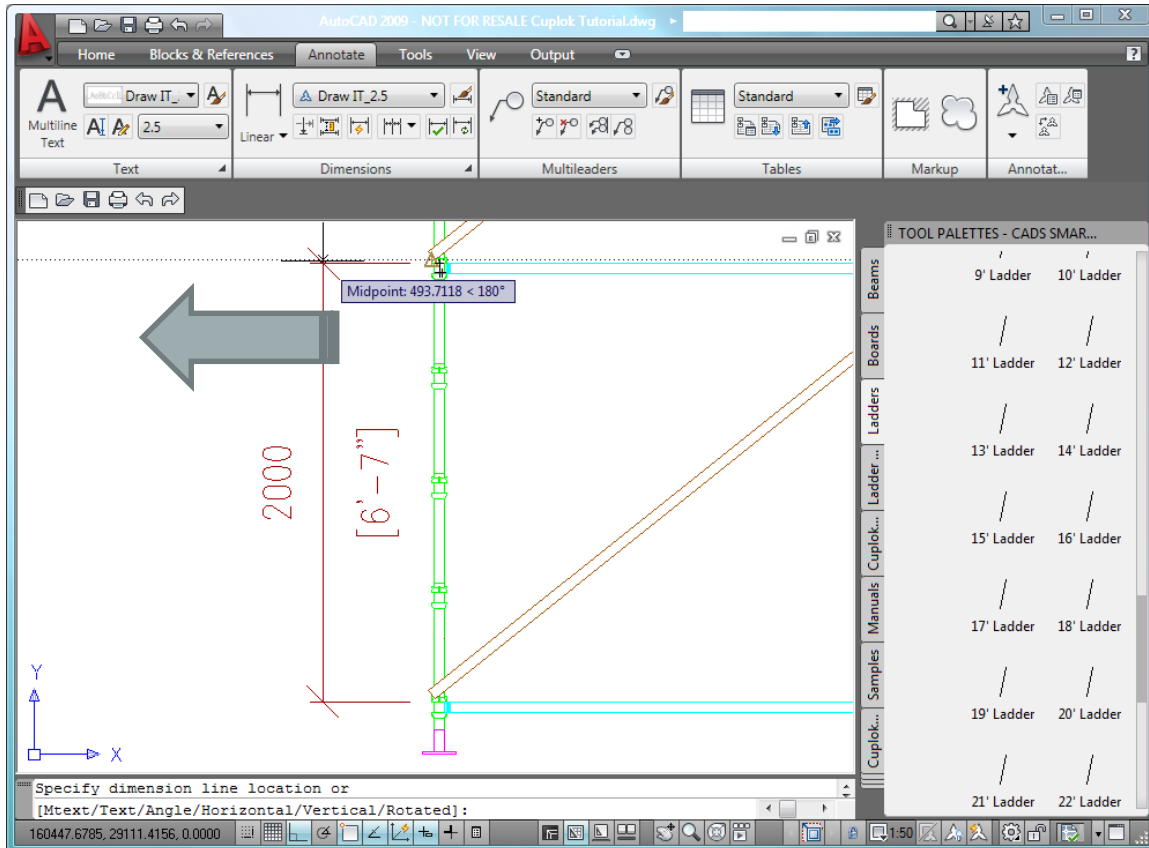

The dimension should be 2000 because the first lift is 2.0m high. If a different value is displayed then you may not have clicked on exactly the correct point: use the **Undo** option and try again – you can zoom in further if you need to.

Clicking on the cups helps you to ensure that you have selected the same point on each lift so that the correct dimension will be displayed.

- You can now repeat this process to dimension the bay length. Select the **Linear** dimension option again, but this time move the mouse to the middle of the first base plate so that the **Midpoint** grip appears. Click on the point, move the mouse to the **Midpoint** of the second base plate, and click again. Then move the mouse downward and click to place the dimension:

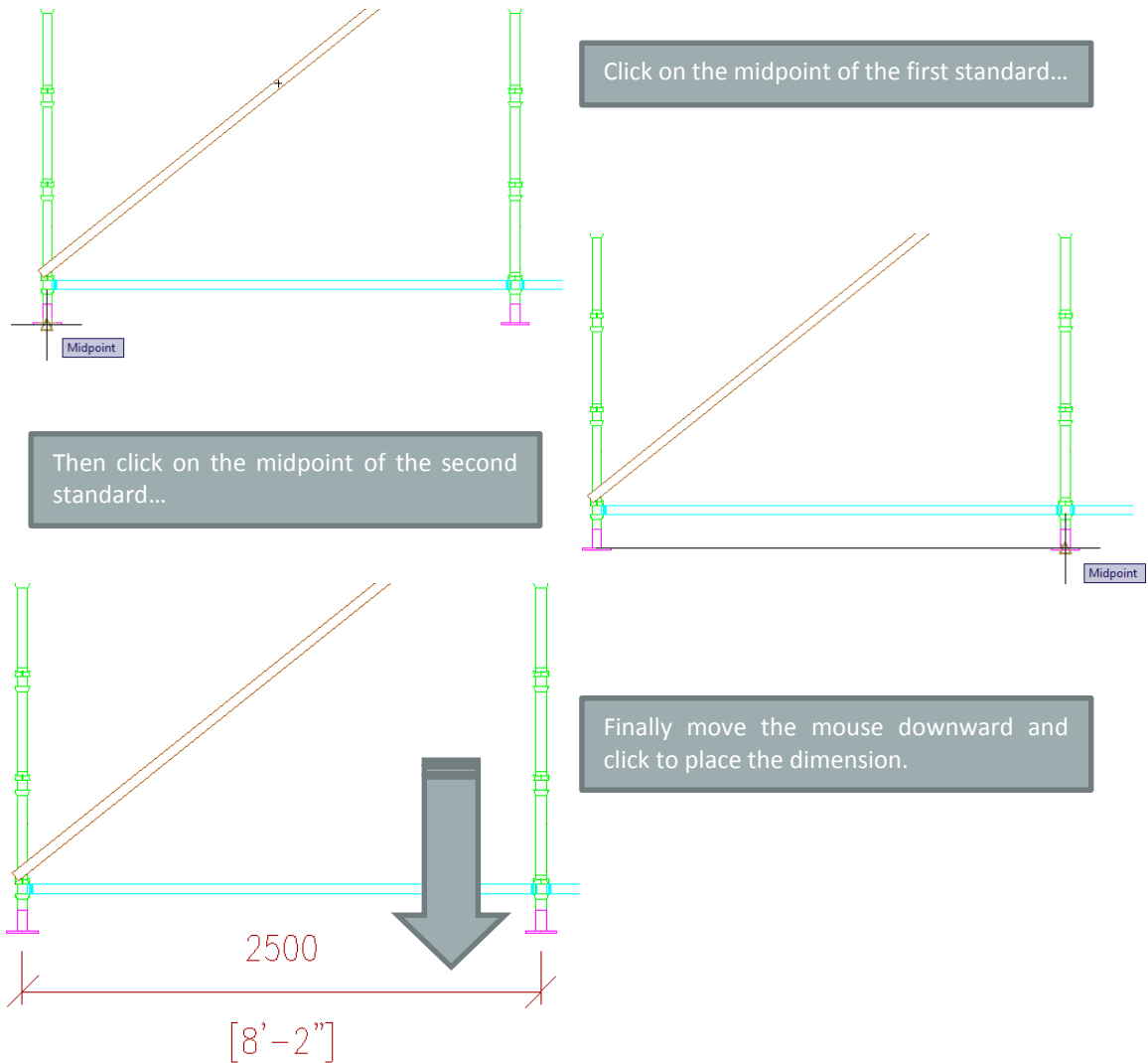

This completes the placement of the dimensions.

1.6.2 Step 6b: Adding Stamps

SMART Scaffolder **Draw IT 2016** is supplied with a number of predefined stamps that include standard text such as CDM Regulations, the maximum working load for the scaffold, and so on.

1. Change to the **Stamps** tab on the tool palette.
2. To place a stamp, simply drag and drop it from the **Stamps** tool palette.
3. Drag and drop the **Plan** stamp from the **Stamps** tool palette below the scaffold plan view. Repeat this process for the **Elevation** and the **Side Elevation**:

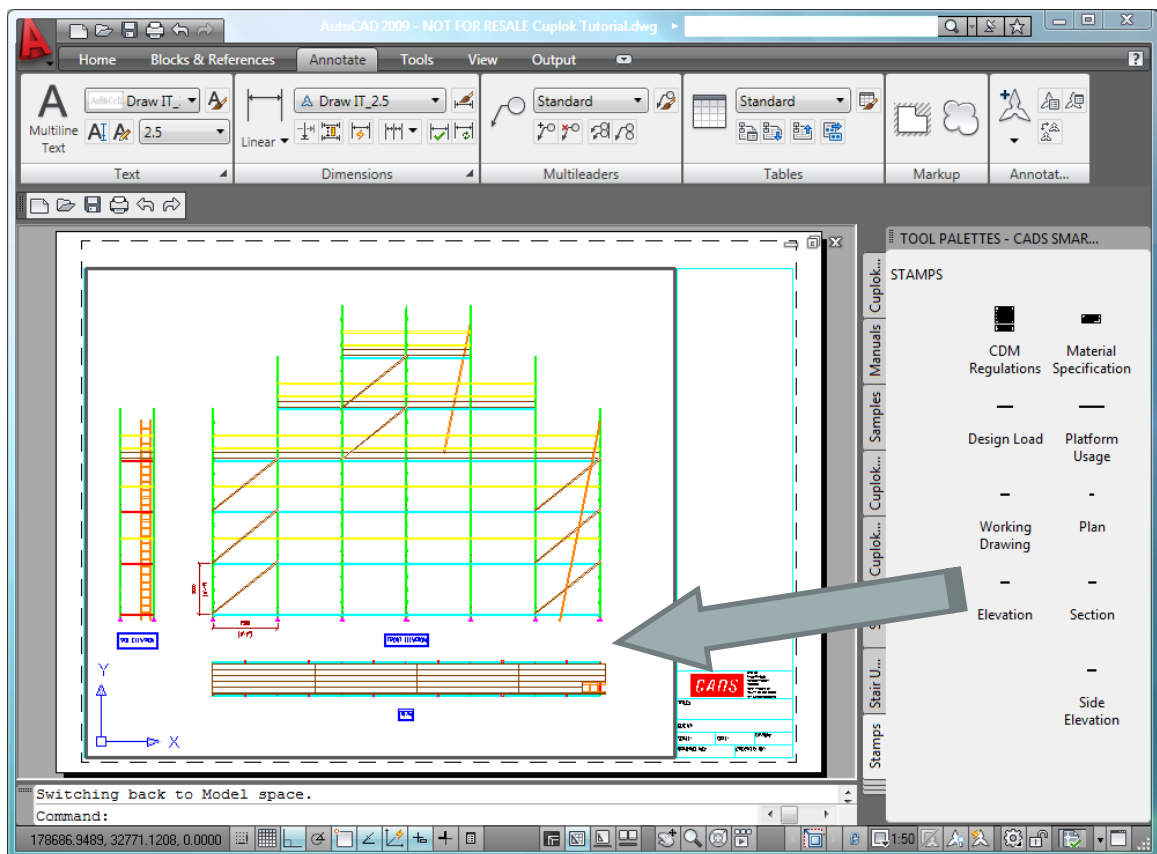

Some stamps, like the **Design Load** stamp, allow you to enter values in a dialog box. The information you type in will be displayed in the stamp.

4. Drop the **Design Load** stamp onto the drawing.
5. Enter **2.0** in the dialog to specify a maximum load of 2.0kN/m².

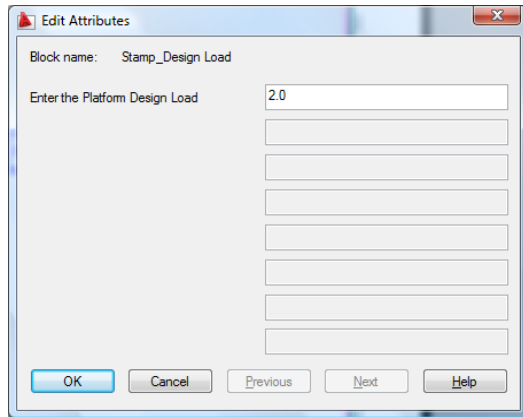

This completes adding Stamps to the drawing.

1.6.3 Step 6c: Title Block

The final step is to complete the title area to enter the details of the drawing.





The title area is in AutoCAD *paper space*, so double-click outside of the drawing area to activate it.

The title area allows you to enter information about the drawing:

Section	Description
Drawn	The initials of the person who created the drawing.
Scale	The drawing scale.
Checked By	The initials of the person who checked that the drawing is correct.
Date	The date on which the drawing was completed.
Drawing No	A unique number to reference the drawing, usually based on the contract number.
Title	A brief title to describe the drawing.
Client	The name of the client company.

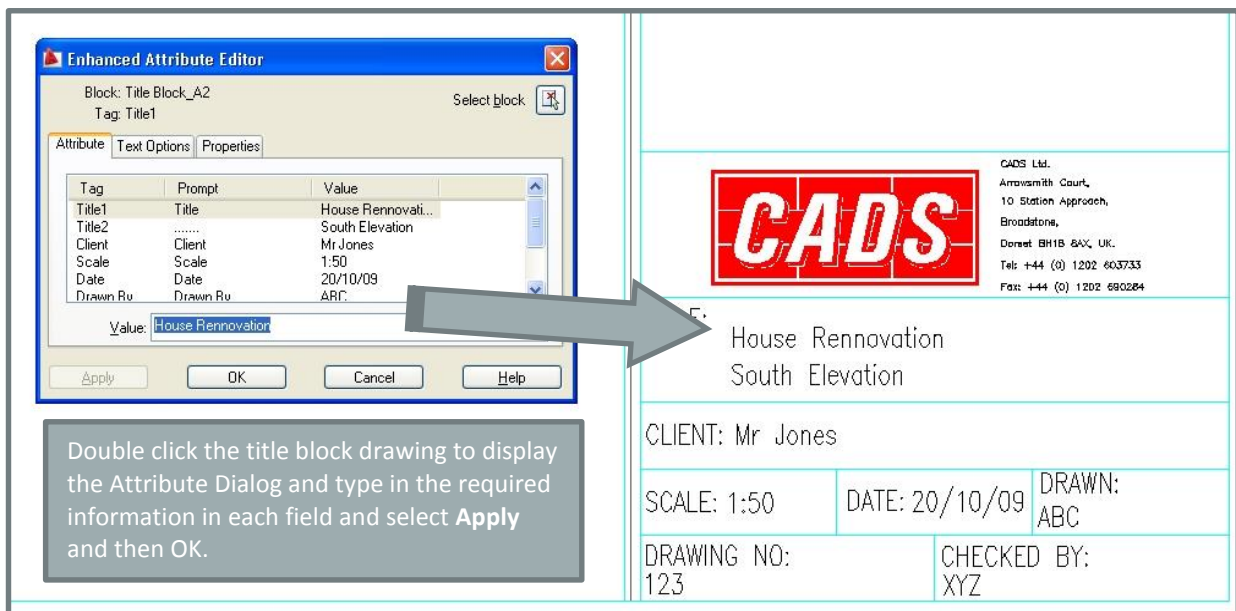
1. To display the Title Block text dialog box double click on any part of the title block drawing.
2. Highlight the **Title 1 attribute**.
3. Click into the **Value field** and type in the Title of the drawing.
4. Pick **Apply**.
5. Pick each attribute in turn and type in the required text in the **Value field** and pick **Apply**.
6. Pick **Ok** to exit the dialog.



Double click the title block drawing to display the Attribute Dialog and type in the required information in each field and select **Apply** and then **OK**.

		CADS Ltd. Arrowsmith Court, 10 Station Approach, Broadstone, Dorset BH15 8AX, UK. Tel: +44 (0) 1202 603733 Fax: +44 (0) 1202 680284
House Renovation South Elevation		
CLIENT: Mr Jones		
SCALE: 1:50	DATE: 20/10/09	DRAWN: ABC
DRAWING NO: 123		CHECKED BY: XYZ

This completes adding the text to the title block area.

1.7 Step 7: Drawing an Irregular Scaffold

The regular scaffold drawn using this tutorial is not very representative of real-world conditions: scaffolds are rarely built in regular bays and lifts.

SMART Scaffolder **Draw IT 2016** allows you to draw complex scaffolds by dragging and dropping individual components, for example in the manner that boards were placed during the tutorial. It is possible to draw any configuration of system scaffolding by dragging and dropping individual standards, horizontals, and boards – plus it is also possible to drag and drop tube and fitting components too, as described in the *Tube and Fitting Tutorial*.

However, it is not always necessary to start from scratch and build every component individually: it is also possible to **explode** a dynamic scaffold, removing its intelligence and converting it into individual components that can be modified. This enables you to quickly build the majority of the scaffold using intelligent dynamic blocks, then explode the scaffold into its components to make the required adjustments.

This tutorial will show how to replace the guard rails with double guard rail frames and how to remove a standard to build a bridge over an obstruction.

1.7.1 Step 7a: Exploding the Scaffold into Components

Once you have created your basic scaffold using *dynamic blocks* you can explode them into their constituent components for more detailed editing.



Exploding a dynamic block allows you to edit the individual components but you lose the intelligent grips that allow you to modify the lifts, bays, boards, and guard rails.

To explode the scaffold:

1. Double-click within the viewport to ensure that it is active.
2. Press the **Esc** key so that you are sure that nothing is selected.
3. Click on the front elevation of the scaffold;
4. Click on the **Explode** button in the **Modify** section of the **Home** toolbar, or type **explode** and press the **Enter** key.



1.7.2 Step 7b: Adding Double Guardrail Frames

This step of the tutorial demonstrates how to replace components from the dynamic scaffold elevation with individual components from the catalogue.

1. Ensure that the front elevation and the gable end have been exploded by following the instructions in the previous step.
2. Delete the guard rails from the top lift and the two gable lifts by clicking them with the left mouse button and pressing the **Delete** key. You can do this most easily by selecting all of the guard rails first and pressing the **Delete** key once to delete them all.



Alternatively you could switch off the guard rails first using the dynamic block, and then explode the scaffold.

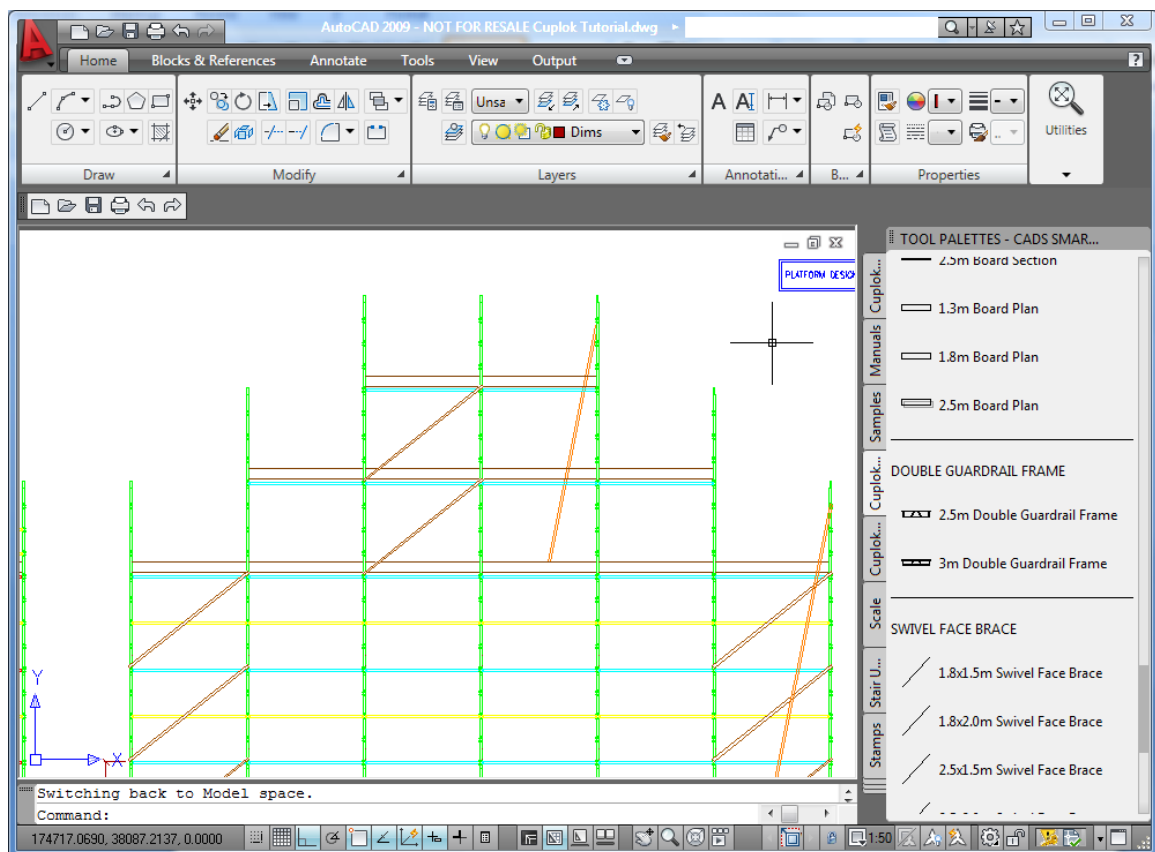

3. Switch to the **Cuplok Scaffold System** tool palette tab and scroll down so that the **Double Guardrail Frame** components are visible.

4. Drag and drop the **2.5m Guardrail Frame** component onto each bay by clicking on the second cup above the lift level. You may find it helpful to zoom in using the mouse wheel to make it easier to slot the guardrail into the cup.

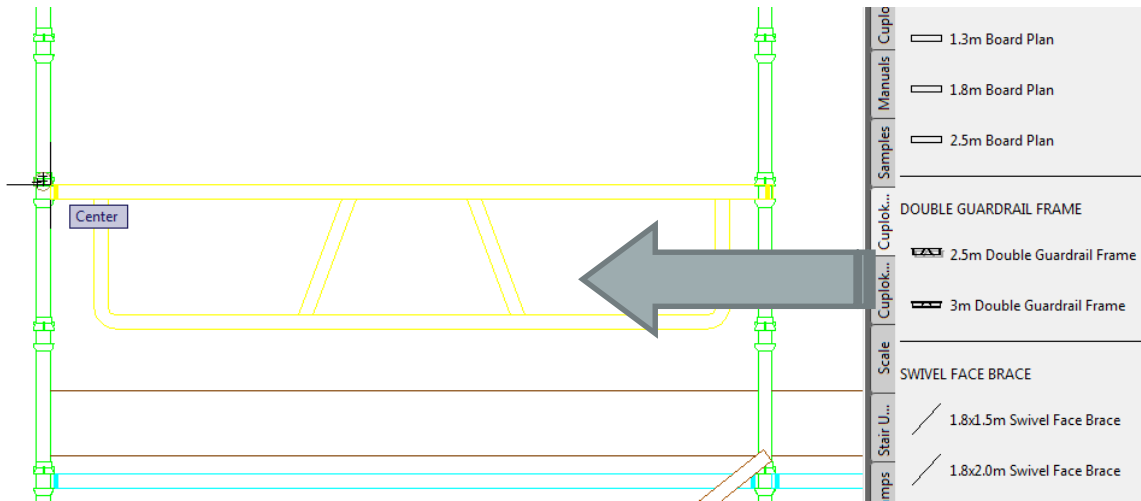

5. Repeat this for each bay to complete the guardrail frames:

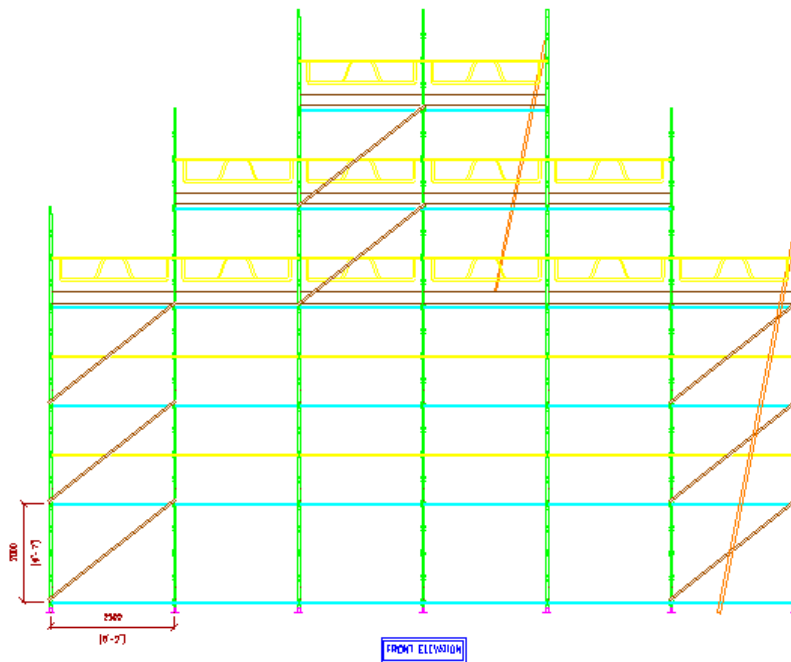

1.7.3 Step 7c: Adding a Bridge

A bridge can be drawn by deleting components from the drawing and adding a truss beam.

1. Use an AutoCAD **crossing window** to select all of the components within the first two lifts of the third and fourth bays.

To do this, click the left mouse button below the base level of the fourth lift and move the mouse cursor up and to the left. Click the left mouse button when the mouse cursor is above the first guard rail in the third bay:

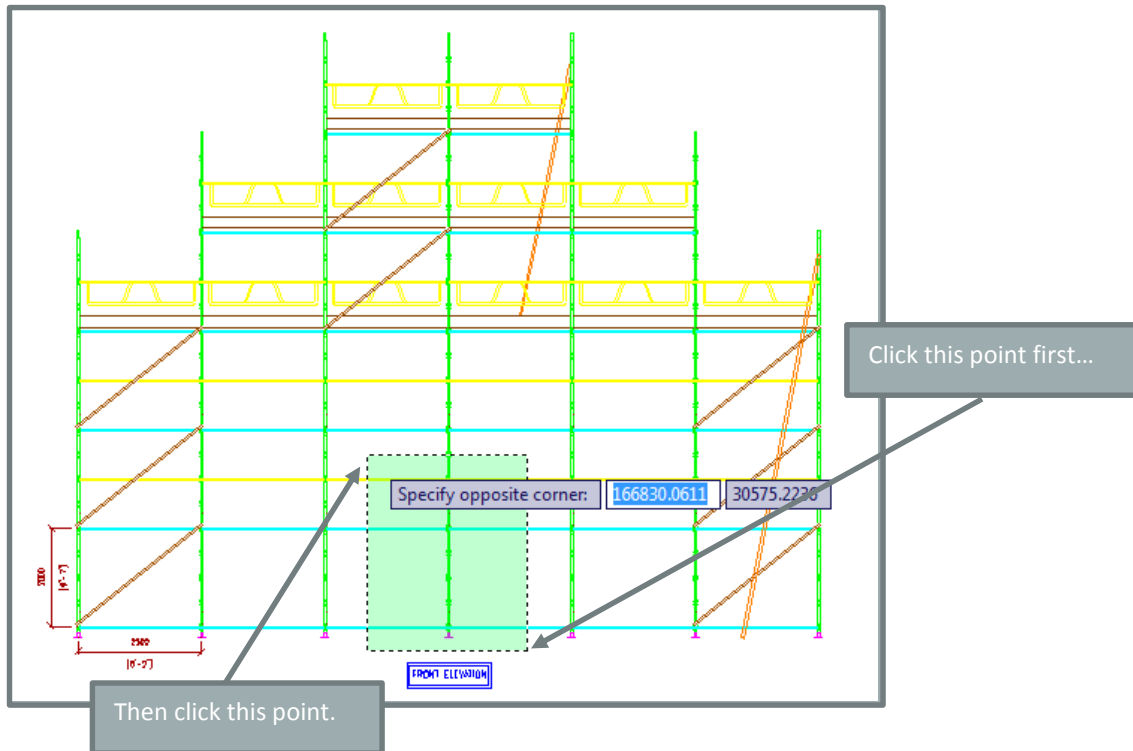

2. Press the **Delete** key to erase the components.

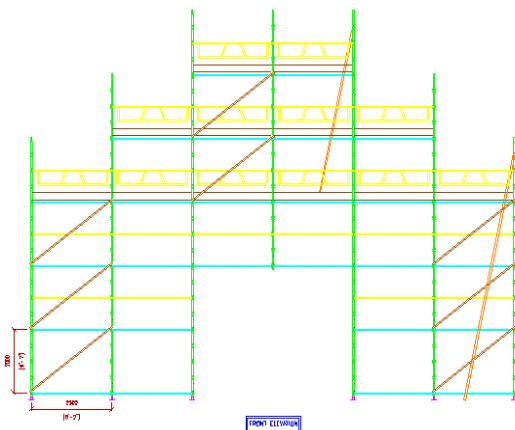

3. To place a truss beam, switch to the **Beams** tool palette and drag and drop a **5m Beam** onto the drawing over the bridge.

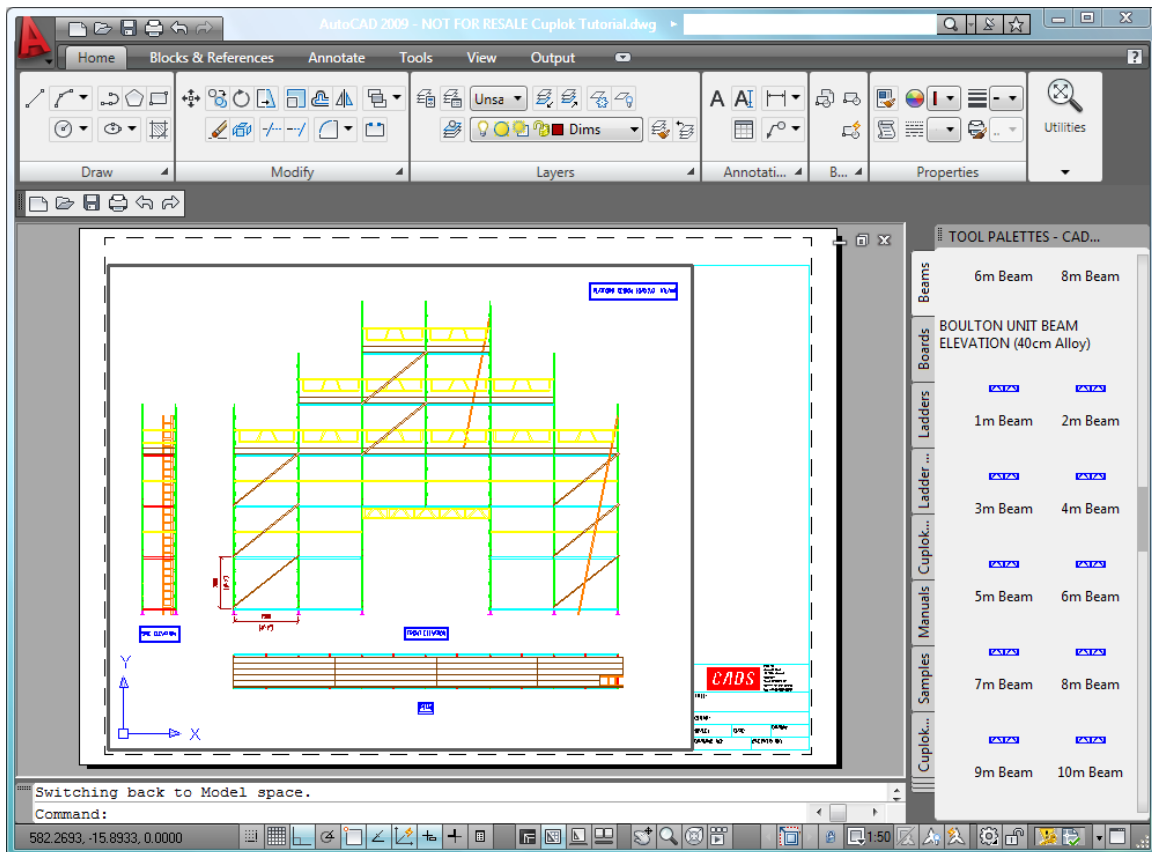

This completes the tutorial! Congratulations for working through to the end.

Feedback

Thank you for choosing CADS SMART Scaffolder.

We are always striving to improve the product so please contact us with your feedback. We are always keen to hear new ideas and if you experience any problems with the software we want to hear about them so that they can be resolved.



You can contact us via:

- ▶ Our website support centre at www.smartscaffolder.com/smart_scaffolder_support.html;
- ▶ Email on support@cad.s.co.uk;
- ▶ Telephone on (01202) 603733 from Monday to Friday between 09:30 and 17:00.