



# OpenScape Business V3

**VoIP Interfaces (LAN/WAN)**

How To

V3.0

**Atos**

# Inhalt

<b>History of Changes .....</b>	<b>3</b>
<b>1 Supported Interface configurations .....</b>	<b>4</b>
1.1 WAN interface not used (LAN only) .....	5
1.2 WAN configured as TCP/IP interface .....	6
1.3 WAN configured as DSL interface .....	7
1.4 LAN and WAN in parallel .....	8
<b>2 General Restrictions .....</b>	<b>9</b>
<b>3 References .....</b>	<b>10</b>

# History of Changes

Date	Issue	Summary
2015-04-20	1.0	initial creation for OpenScape Business V2
2017-01-09	1.1	update Web-links for Device@Home
2017-07-20	2.0	update for V2R3 <ul style="list-style-type: none"><li>• add Circuit and Skype for Business</li></ul>
2022-06-07	3.0	update for V3R2 <ul style="list-style-type: none"><li>• no support of onboard VPN</li><li>• add Unify Phone / Unify Office / MS Teams (direct routing)</li></ul>

Comments and corrections are welcome, please contact: [osbiz-certification@atos.net](mailto:osbiz-certification@atos.net)

# 1 Supported Interface configurations

The following chapters describe examples for installation, administration and operation of the OpenScape Business LAN and WAN interface constellations for the signaling (SIP, SIPQ and HFA).

OSBiz-X      embedded system (all variants of V3 mainboard and V2 mainboard families)

OSBiz-S      all variants of Server and virtualization environments

# 1.1 WAN interface not used (LAN only)

In this configuration OpenScope Business is connected to the network via the LAN interface only. The WAN interface is NOT used. If VPN connections are necessary, these connections MUST be maintained by the connected routers. The VPN client in OpenScope Business is NOT used. This configuration is valid for OSBiz-X and OSBiz-S.

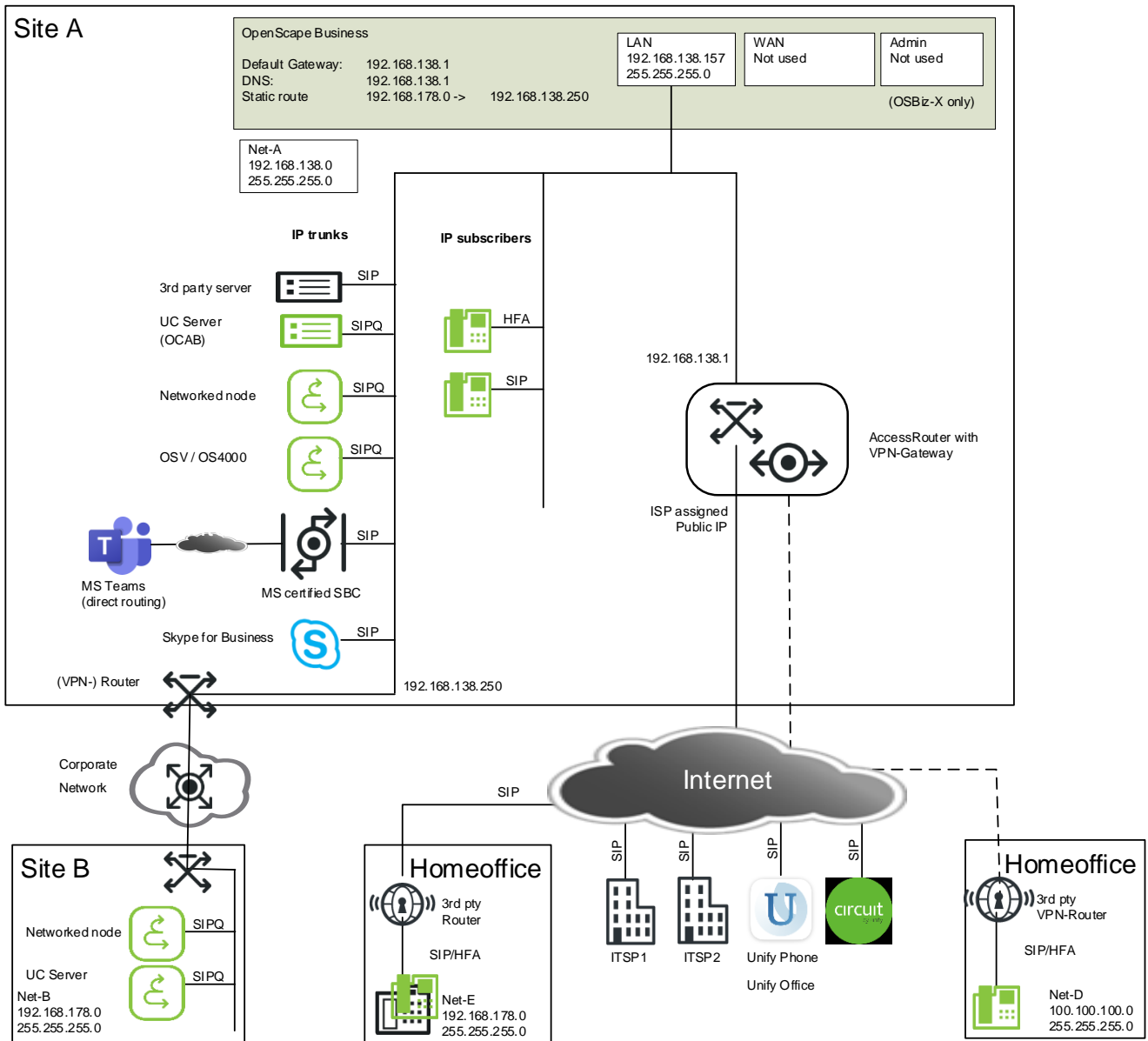

## Configuration hints:

- Static routes MUST be configured to other sites which are not reachable via the default router
- The connection to a Home office using Unify HFA/SIP phones (Device@Home) is possible:
  - via a configured VPN tunnel in the Access Router
  - via a direct connection using UDP or TLS, see separate documentation System Device@Home – Configuration [10]

## 1.2 WAN configured as TCP/IP interface

If the WAN interface is configured in TCP/IP mode all VoIP connections to the internet MUST be done via the WAN interface. All other VoIP devices MUST be connected via the LAN interface. This configuration is valid for OSBiz-X and OSBiz-S.

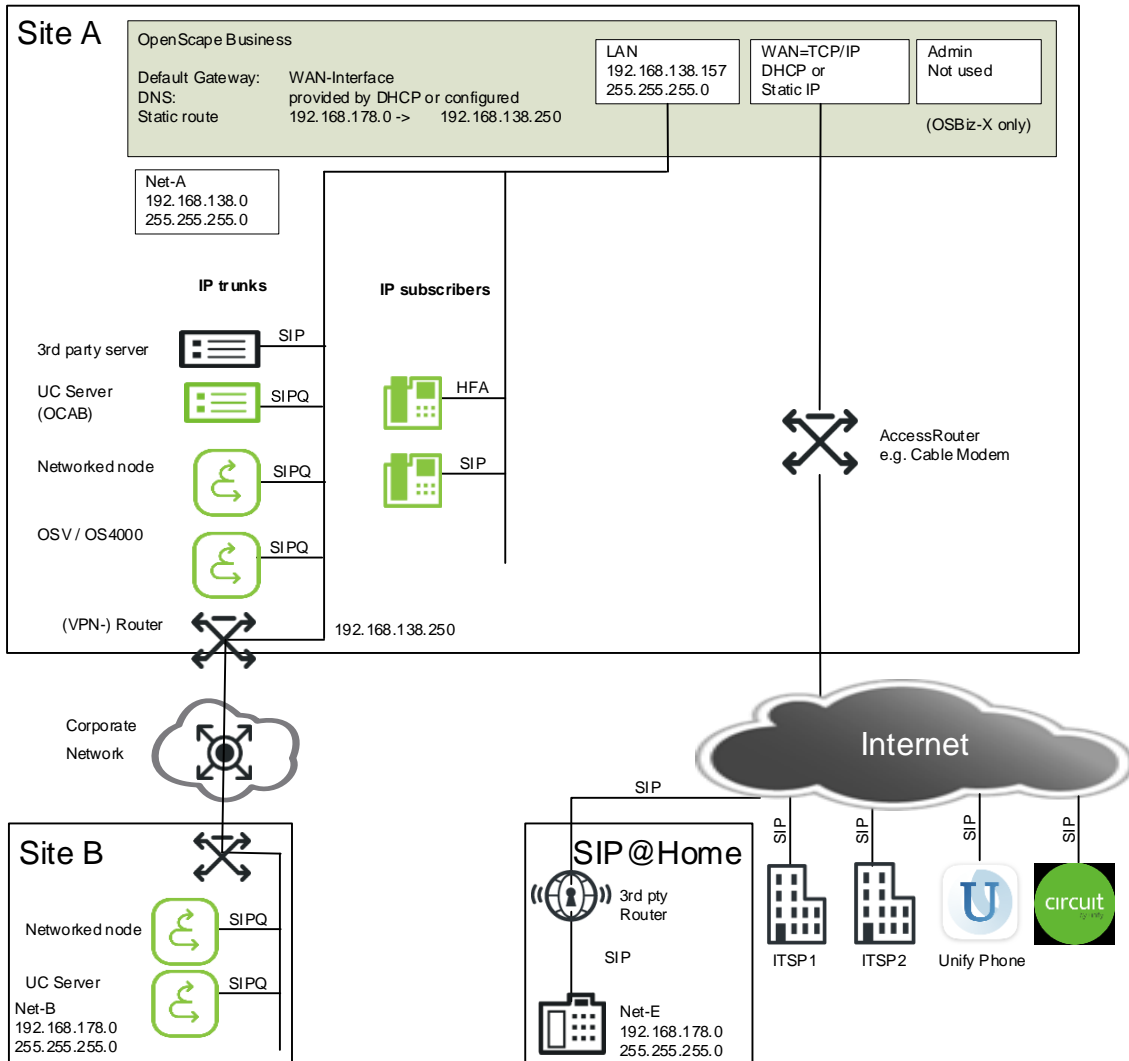

### Configuration hints:

- no ITSP, Unify Phone and Circuit connections possible via LAN
- Unify Office, MS Teams (direct routing) and Skype for Business connections are not possible in this configuration
- static routes MUST be configured to other sites which are not reachable via the default router
- the WAN=TCP/IP interface can be operated either in DHCP mode or with static assigned IP-Address (depends on the provided access Router)
- SIP@Home scenarios are possible using UDP only, see separate documentation documentation System Device@Home – Configuration [10]



## 1.3 WAN configured as DSL interface

If the WAN interface is configured as DSL interface to establish the internet connection all traffic towards the internet MUST use the WAN interface. All other VoIP devices MUST be connected via the LAN interface. This configuration is valid for OSBiz-X only.

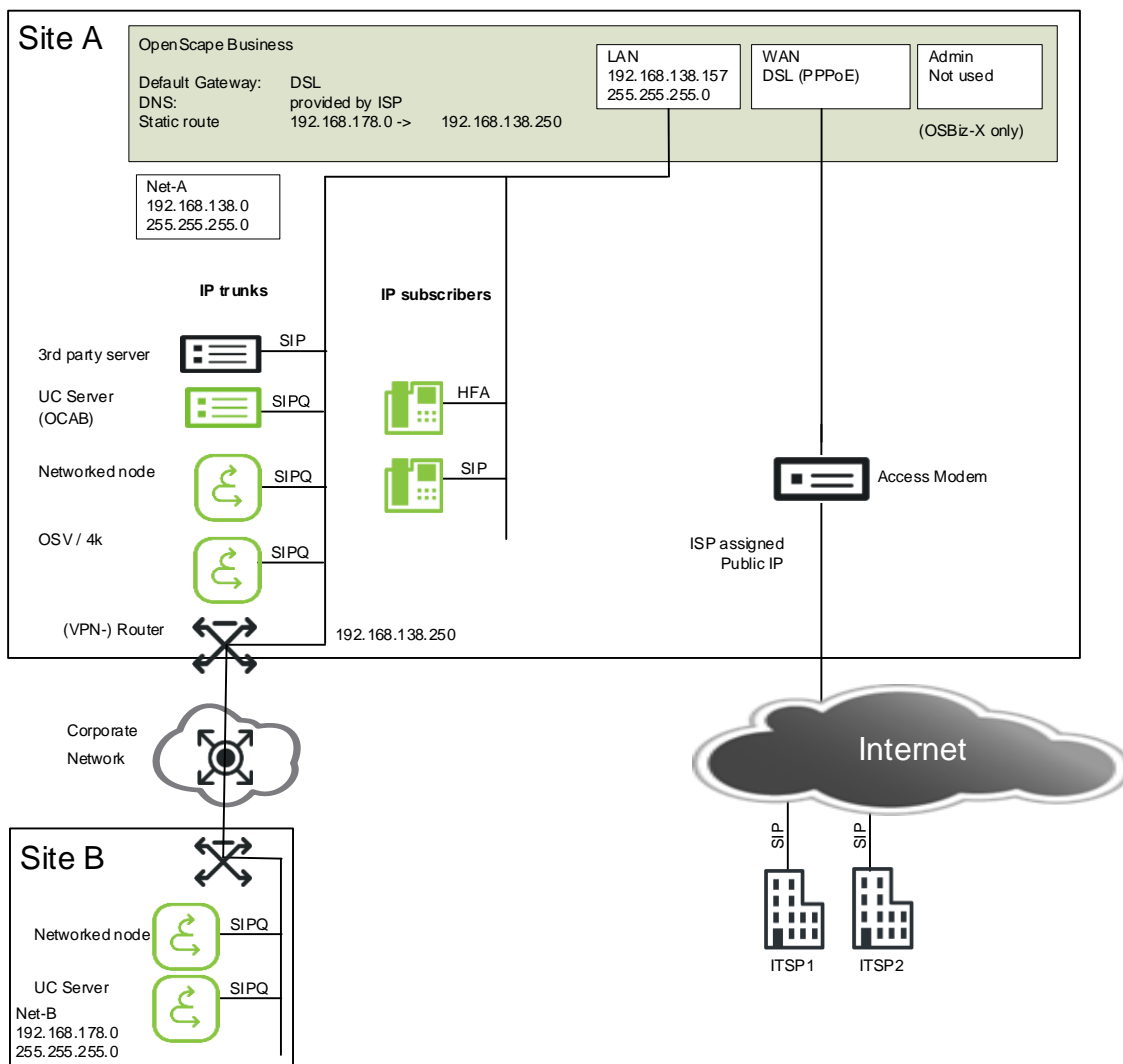

Configuration hints:

- the integrated DSL Router is suitable for small installations only. For larger installations an external Router MUST be used (see 1.1 and 1.2)
- no ITSP connection possible via LAN
- this configuration is not released for Unify Phone, Unify Office, Circuit, MS Teams (direct routing) and Skype for Business connections
- static routes MUST be configured to other sites which are not reachable via the default router (DSL)
- Device@Home scenarios are **not** supported in this configuration, see separate documentation System Device@Home – Configuration [10]

## 1.4 LAN and WAN in parallel

When the WAN interface is configured, all ITSP connections MUST use this interface.

It is strongly recommended to use the same interface for ITSP connections and all other internet traffic (either all over LAN or all over WAN).

Nevertheless, under certain circumstances a customer wants to have a different setup, where the system will use the WAN for ITSP connections whereas the default router to the internet is located at the LAN interface.

In such a configuration several issues may prevent successful VoIP calls. At least the following configuration MUST be done:

- manual configuration of routing  
As the default router is connected to the LAN interface, all destinations which needs to be addressed for ITSP calls MUST have static routes. This MUST include all needed SIP servers (Proxies, Registrar) as well as all possible media endpoints. Static routes must be configured with appropriate means (e.g. WBM in OSBiz-X, Yast in OSBiz-S)  
This manual configuration is not necessary if the WAN interface has an address out of the ITSP network. (ITSP operating a private VoIP network with or without access device)
- Firewall configuration  
The firewall located between the ITSP and the WAN interface MUST be manually opened on all ports needed for ITSP connections. This MUST include all needed SIP servers (Proxies, Registrar) as well as all possible media endpoints.
- STUN  
In this configuration STUN cannot be used to determine the public IP-Address. STUN MUST be switched off or used with static IP address (at the WAN router).
- Due to the restriction that ALL ITSPs MUST use the same interface, this configuration is limited to ONE ITSP only.



## 2 General Restrictions

- As the WAN interface is intended to be used as the ITSP interface it is **NOT** allowed to address this interface by
  - any IP-Endpoints at the WAN interface (HFA and SIP)
  - any networked nodes
- If two (or more) ITSP's are configured in the system
  - all ITSP's **MUST** use the same internet connection
  - usage of STUN can be switched on or off individually for each provider, but **ALL** providers **MUST** share the same STUN mode (e.g. automatic, port preserving router, ...) and will use the same STUN server (even if different STUN servers may be configured at the ITSP's).
- The Admin-Interface of the OSBiz-X cannot be used to connect any type of VoIP endpoints or trunks.
- The LAN2-Interface of the OCAB cannot be used to connect any type of VoIP endpoints or trunks.
- In scenarios where the WAN interface is used, NAT is activated at the WAN interface.

# 3 References

Further related information can be found under the following links:

Reference	Hyperlink
[1] Administration Documentation	Online Help in OpenScape Business Assistant
[2] Diagnostic hints	Administration Documentation
[3] Experts Wiki	<a href="http://wiki.unify.com/wiki/OpenScape_Business">http://wiki.unify.com/wiki/OpenScape_Business</a>
[4] OpenScape Business Security Checklist	<a href="https://nuxeo.unify.com/nuxeo/site/proxy/nxdoc/view/raw/b2efab60-4ba8-491c-988d-870077267c4a">https://nuxeo.unify.com/nuxeo/site/proxy/nxdoc/view/raw/b2efab60-4ba8-491c-988d-870077267c4a</a>
[5] Unify Phone Administration	<a href="https://nuxeo.unify.com/nuxeo/site/proxy/nxdoc/view/raw/cdef0909-d6d6-478c-8d45-d59a9d16a35b">https://nuxeo.unify.com/nuxeo/site/proxy/nxdoc/view/raw/cdef0909-d6d6-478c-8d45-d59a9d16a35b</a>
[6] How To OpenScape Business Connector to Circuit	<a href="https://wiki.unify.com/images/0/01/How_To_Configure_Circuit_OpenScape_Business_Connector.pdf">https://wiki.unify.com/images/0/01/How_To_Configure_Circuit_OpenScape_Business_Connector.pdf</a>
[7] How To MS Teams Interworking	<a href="https://wiki.unify.com/images/4/4f/How_To_Configure_OSBiz_MS_Teams_Interworking.pdf">https://wiki.unify.com/images/4/4f/How_To_Configure_OSBiz_MS_Teams_Interworking.pdf</a>
[8] How To Skype for Business Teams Interworking	<a href="https://wiki.unify.com/images/3/31/How_To_Configure_OSBiz_Skype_for_Business_Interworking.pdf">https://wiki.unify.com/images/3/31/How_To_Configure_OSBiz_Skype_for_Business_Interworking.pdf</a>
[9] "How to collection" for H4k and OSV networking	<a href="https://wiki.unify.com/wiki/How_to_collection_and_tutorials_for_OpenScape_Business#Networking">https://wiki.unify.com/wiki/How_to_collection_and_tutorials_for_OpenScape_Business#Networking</a>
[10] System Device@Home - Configuration	<a href="http://wiki.unify.com/wiki/How_to_collection_and_tutorials_for_OpenScape_Business#Device.40Home">http://wiki.unify.com/wiki/How_to_collection_and_tutorials_for_OpenScape_Business#Device.40Home</a>

Our Quality and Environmental Management Systems are implemented according to the requirements of the ISO9001 and ISO14001 standards and are certified by an external certification company.

Copyright © Unify Software and Solutions GmbH & Co. KG, 2022  
All rights reserved.

The information provided in this document contains merely general descriptions or characteristics of performance which in case of actual use do not always apply as described or which may change as a result of further development of the products.  
An obligation to provide the respective characteristics shall only exist if expressly agreed in the terms of contract.

Availability and technical specifications are subject to change without notice.

Unify, OpenScape, OpenStage and HiPath are registered trademarks of Unify Software and Solutions GmbH & Co. KG. All other company, brand, product and service names are trademarks or registered trademarks of their respective holders.

[atos.net](http://atos.net)

The logo for Atos, featuring the word "Atos" in a bold, white, sans-serif font. The letter 'o' is stylized with a white outline and a small white dot in the center, giving it a circular appearance.