



OPERATOR'S MANUAL

TYPE 462 ENGINES

EQUIPPED WITH

BOSCH CONTACT BREAKER
IGNITION SYSTEM AND

BING CARBURETOR

Edition: 04 1988



BOMBARDIER-ROTAX GMBH
MOTORENFABRIK

A-4623 Günskirchen - Austria
Telefon: (07246) 271-0*, Telex: 25546 brk a
Telegrammadresse: Bombrotax Günskirchen



FOR HISTORICAL REFERENCE PURPOSES ONLY: THIS INFORMATION MAY BE OUTDATED!

Table of Contents

Page	
2	Fuel / Fuel Oil Mixture
3	Break-in Procedure
4	Rotary Valve Adjustment / Carburetor
6	Starting the engine / Spark Plug
7	Ignition Unit
8	Adjustment of Ignition Timing / Pole Shoe Gap
9	Wiring Diagram
10	Ignition Damping Box / Wiring Diagram for mounting ignition damping box 866 572
11	Lighting Circuit
12	Wiring Diagrams for rectifier-regulator 866 080
13	Wiring Diagrams for rectifier-regulator 264 870
14	Rewind Starter / Changing the starter rope
16	Decarbonizing / Main Torquing Specifications
18	Fault-Tracing-Schedule
20	Liquid - Cooling System
21	Gear for rotary valve and liquid-cooling pump
22	Mounting-, Maintenance- and Safety Instructions for UL - prop gear on ROTAX engine types 377 - 447 - 503 - 462 - 532
24	Service Information type 462 UL - Rotary Valve Adjustment
25	Technical Data

GENERAL

The ROTAX engine is a liquid-cooled 2-stroke engine. Careful and extensively tested design and rugged construction as well as the use of high quality parts warrant maximum reliability and durability. With proper maintenance and care and with the use of suitable fuel and oil the engine will give you trouble-free service for many years.

The ROTAX design incorporates the latest technical developments. In order to take advantage of future developments we reserve the right to make modifications in the ROTAX design without notice.

FUEL

As fuel for engine type 462 UL regular gasoline, leaded or unleaded, octane number not below RON 90 (or MON 83) is prescribed. Premium gasoline can be used, too. If possible, leaded fuel should be used. When using unleaded fuel, only use fuels of recognized brands.

When lead in fuel is omitted, alcohol (methanol, ethanol, isobutanol etc.) is added to avoid knocking. Due to the water absorption of the highly hygroscopical alcohols, the fuel quality cannot be maintained over a long period. Further the alcohol additive causes leaner fuel air mixture (because of oxygen in alcohol) resulting in general in higher engine temperatures.

A higher percentage of alcohol increases the risk of vapour lock due to higher vapour pressure of alcohol.
The alcohol percentage must not exceed 10 %.

FUEL - OIL - MIXTURE

The ROTAX engine is operated by a mixture of standard grade gasoline and

- Super 2-stroke oil

the oil lubricating the moving engine parts.

Mixing ratio fuel - oil is 50 : 1; this mixing ratio has to be respected.

Too much oil will cause carbon deposits on the spark plug, on the piston, in the cylinder ports and in the muffler and will cause problems. In addition, the piston rings may stick.

If too little oil is used, lubrication will be insufficient, the pistons will seize and the bearings will be damaged.

BREAK-IN PROCEDURE

The break-in has to be performed with the engine in the air-frame, loaded with the propeller. Tighten the plane to the ground and run the engine according to the following graph:

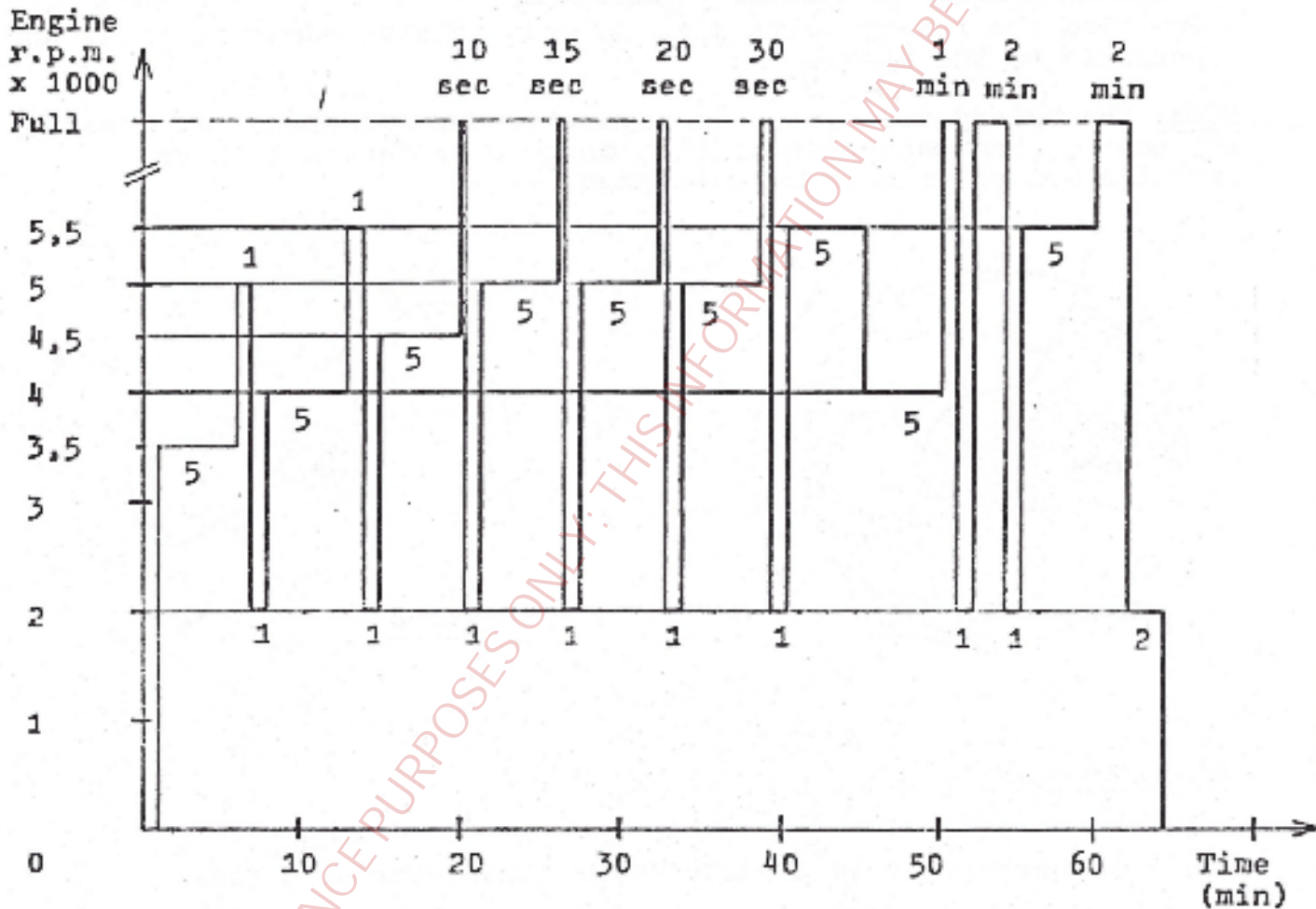

After this procedure the idle has to be adjusted.
Then short take-offs can be conducted.

Rotary Valve Adjustment

Installation:

To correctly install the rotary valve disc proceed as follows:

- Turning crankshaft counter-clockwise (drive pulley side), bring magneto side piston to Top Dead Center using a T.D.C. gauge.
- Position the rotary valve disc on gear to have edges as close as possible to the marks.

NOTE: The rotary valve disc is asymmetrical, therefore, at assembly try positioning each side of disc on gear to determine best installation position. See also page no. 24

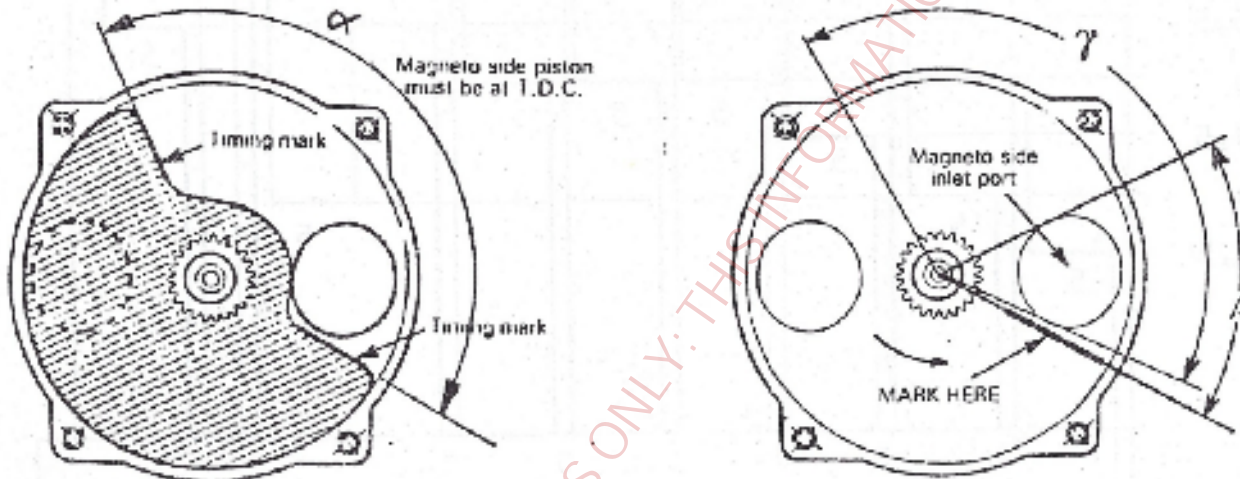

CARBURETOR

The BING carburetor is a piston type carburetor with float chamber. The carburetor can be adjusted by jets and adjusting screws. Changing of jets should only be done by a specialist or after consulting the engine manufacturer.

The air-fuel mixture at idle speed is adjusted by the air adjusting screw (see ill. no. 28).

The idle r.p.m. is adjusted by the carburetor piston adjustment screw (ill. no. 30).

Note: The carburetor must be in an exact right angle position in relation to the crankshaft in both views from top and from the intake side to ensure an equal mixture distribution to both cylinders. Take care that end of both ventilation tubes (ill. no. 31) are protected from

BING-Carburetor

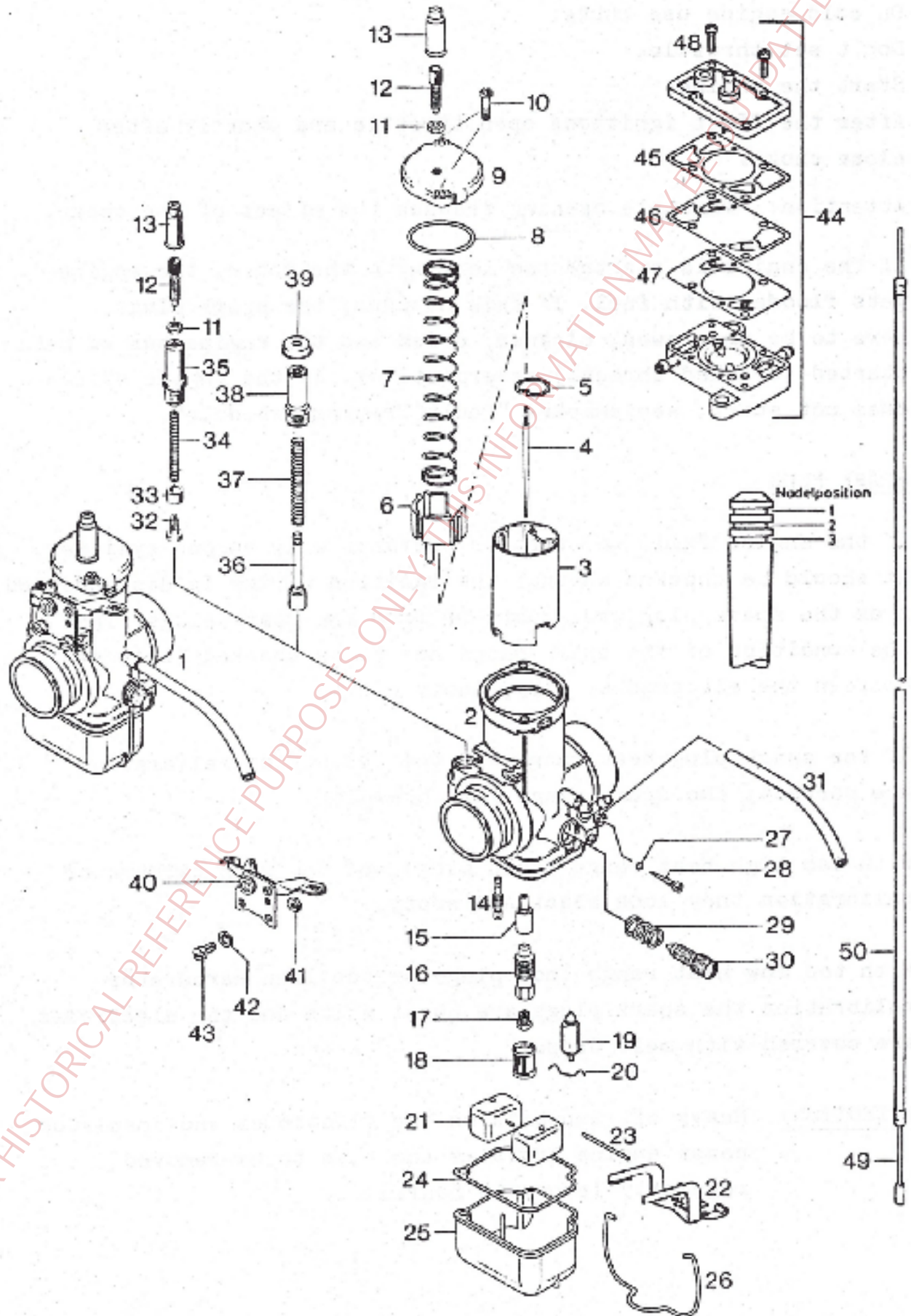

STARTING THE ENGINE

On cold engine use choke.

Don't set throttle.

Start the engine.

After the first ignitions open throttle and shortly after close choke.

Attention: Throttle opening reduces the effect of the choke.

If the engine is started too long with the choke, the engine gets flooded with fuel. If this happens, the spark plugs have to be unscrewed, cleaned, dried and the engine has to be started (cranked through) several times. If the engine still does not start, see chapter "Fault Tracing Schedule".

SPARK PLUG

If the engine fails to start or operates only on one cylinder, it should be checked whether the ignition wiring is disconnected from the spark plug protectors or from the spark plugs. Then the condition of the spark plugs has to be checked (bridged between the electrodes, oily, sooty etc.).

If the spark plug heat range and the carburetor calibration are correct, the spark plugs look brownish.

With too high heat range (cold plug) and too rich carburetor calibration they look black and sooty.

With too low heat range (hot plug) or too lean carburetor calibration the spark plugs are burnt white and the electrodes are covered with melt drops.

ATTENTION: Heavy oil deposits on the electrodes and insulator cause engine troubles and have to be removed regularly (every 10 hours).

If even after cleaning or changing the spark plug there is no spark, the spark plug protector and the ignition cables and finally the ignition unit should be checked.

IGNITION UNIT

The ROTAX engine is equipped with a BOSCH magneto generator 12V 140W producing the current necessary for the spark. The ignition unit has been set most carefully and precisely by the factory. Make no changes unless absolutely necessary. In case of troubles observe the following:

If the ignition fails intermittently or if there are other troubles that are due to neither spark plug nor jets nor carburetor, the contact breakers may be the cause.

Contacts must be clean and must not be burnt. With new engines the cam-follower of the contact breaker must still adjust itself. Re-setting of contacts may therefore be necessary after some time. The breaker contacts are accessible after removal of the rewind starter and the starting pulley. The magneto housing need not be removed.

To check whether the ignition timing is correct there is an arrow on the crankcase. Further there is a mark on the magneto housing. At the moment of ignition (i.e. when breaker contacts open, check with test lamp, buzzer etc., connected to shorting cable of the respective cylinder and to mass), the mark on the magneto housing must correspond with the arrow on the crankcase.

ADJUSTMENT OF IGNITION TIMING

The ignition timing is adjusted after loosening the fixing screw G next to the adjusting groove H (see wiring diagram), so that the contact breaker starts opening when the piston is 1,86 mm (18°) before T.D.C.

Check with test lamp or buzzer as described before. When cranking the engine, the breaker contacts must open $0,30 \pm 0,40$ mm ($0,012 \pm 0,015$ in). If this is not the case, turn the stator plate and repeat the above procedure.

POLE SHOE GAP

When correct timing is achieved, check pole shoe break-away gap. The gap must be within 13 to 17 mm or 0,51 to 0,67 in. (see illustration) when the mark on flywheel corresponds with mark on fan housing.

If the break-away gap is out of tolerance, the flywheel may have turned on the crankshaft. Remove flywheel and inspect taper and key. Repair if necessary.

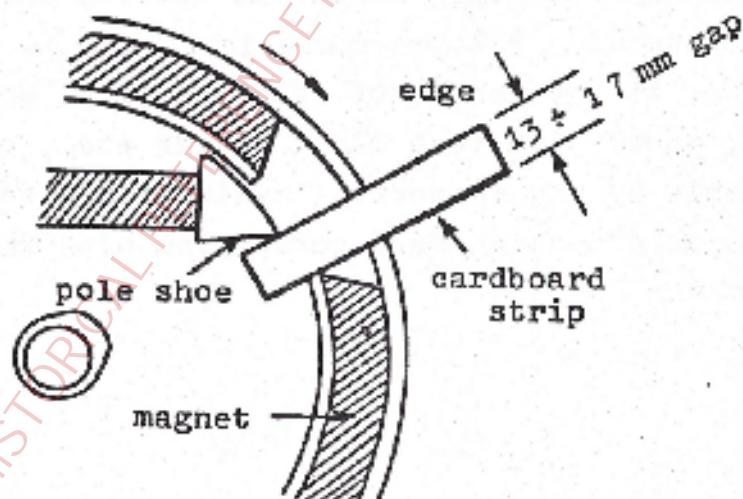

Timing adjustment and repair of ignition units should best be left to a skilled mechanic. Improper handling can easily cause more troubles with such delicate parts.

WIRING DIAGRAM

Particular care has to be taken that the ignition generator cables (J) and the mass cables (M) be correctly connected to the ignition coils (A), see illustration.

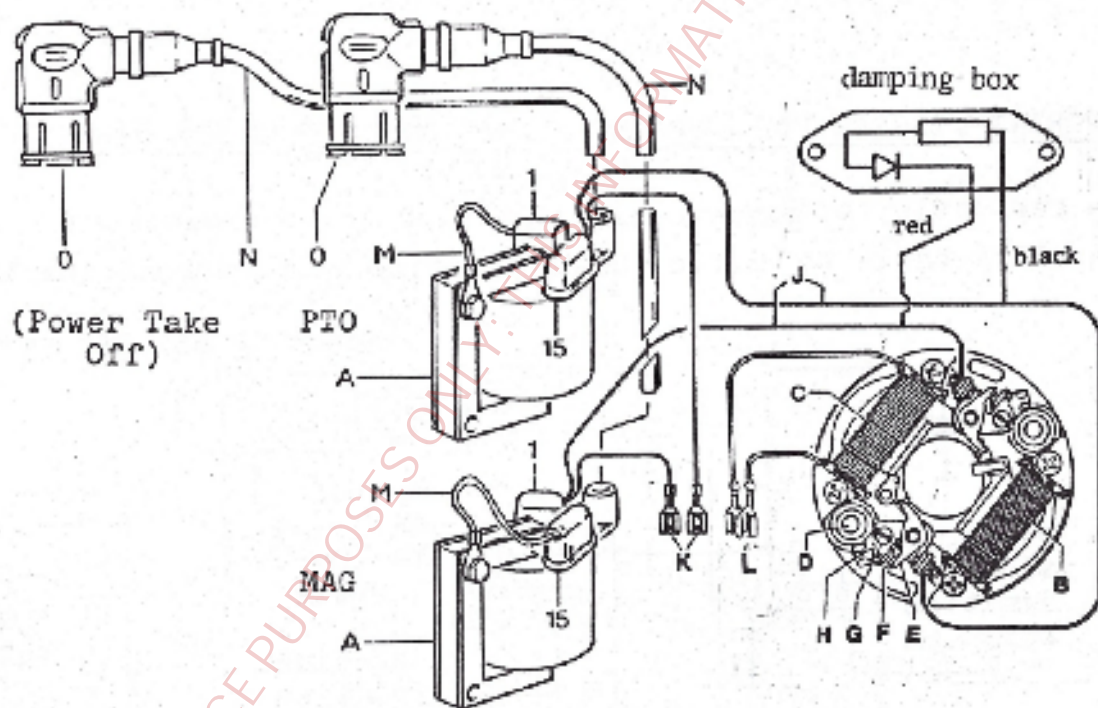

- | | | | |
|---|-------------------------|---|-----------------------|
| A | ignition coils | H | adjusting groove |
| B | generator coil (bottom) | J | generator cables |
| C | lighting coil 30W (top) | K | shorting cables |
| C | lighting coil 110W | L | lighting cables |
| D | condenser | M | mass cables |
| E | contact breaker lever | N | ignition cables |
| F | breaker contacts | O | spark plug protectors |
| G | fixing screw | | |

To cut off the ignition, the 2 shorting cables K have to be connected together and/or to ground.

IGNITION DAMPING BOX

To prevent piston failures caused by glowing of deposits on spark plugs (due to certain fuel additives) it is necessary

- a) to clean the spark plugs every approx. 10 hours of operation or to replace them,
- b) An ignition damping box, part no. 866 572, is mounted on the engine to reduce the spark energy and the glowing of the spark plug deposits.

WIRING DIAGRAM FOR MOUNTING IGNITION DAMPING BOX 866 572

- red cable to magneto side ignition coil, connection 1
- black cable to p.t.o. side ignition coil, connection 15

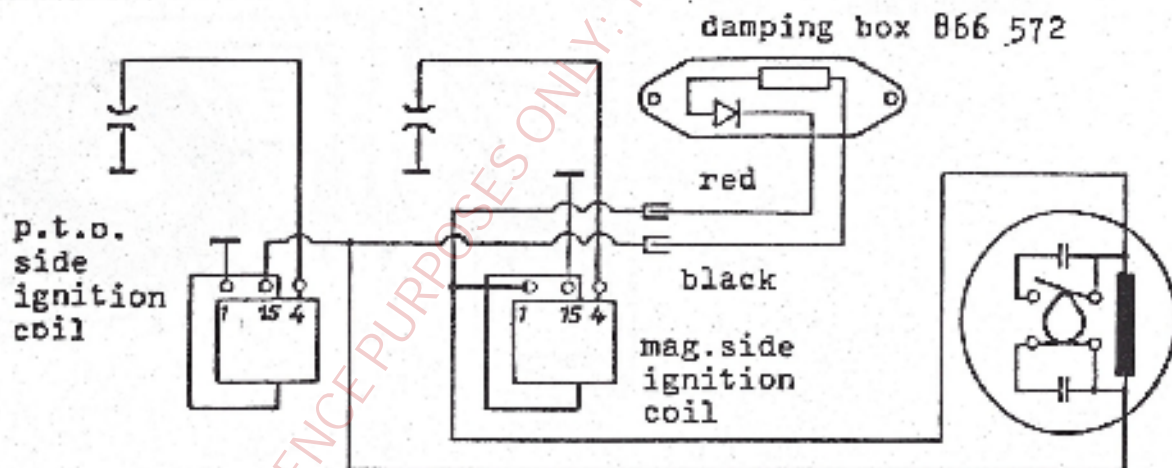

Damping box check

- a) precaution check: Connect damping box with reversed polarity. There must be no spark on both plugs when cranking the engine. If there is still a spark, the damping box is defective.
- b) in case of ignition troubles (no spark): Disconnect damping box, if there is now a spark.

The following error-sources are possible:

- 1) Damping box defect or reverse connected (see a)
- 2) Pole-ring break-away gap out of tolerance (defective Woodruff-key or wrong armature plate adjustment (see page 8)

LIGHTING CIRCUIT

The BOSCH magneto generator produces, apart from the electric current required for the ignition, 12V 140W alternating current which can be directly used for feeding lights and/or other users that can be operated with alternating current.

To avoid the voltage to rise above permissible levels, either users amounting to 140 watts have to be connected, or a voltage regulator has to be used.

To operate users requiring direct current (e.g. battery), a rectifier-regulator is required.

A rectifier-regulator, part no. 866 080, is available. For feeding lights only, this rectifier-regulator can also be used without battery. In this case the regulated RMS voltage will be between 11 and 12 Volts as long as a minimum load of 1 amp is provided.

In case of a battery it has to be capable to absorb approx. 1 amp. minimum continuous charging load, even with full battery (suggested min. battery capacity: 9 amp.h). Regulated voltage is 13.5 to 14.5 volts.

FOR HISTORICAL REFERENCE PURPOSES ONLY. THIS INFORMATION MAY BE OUTDATED!

WIRING-DIAGRAM FOR RECTIFIER-REGULATOR 866 080

in a circuit without battery

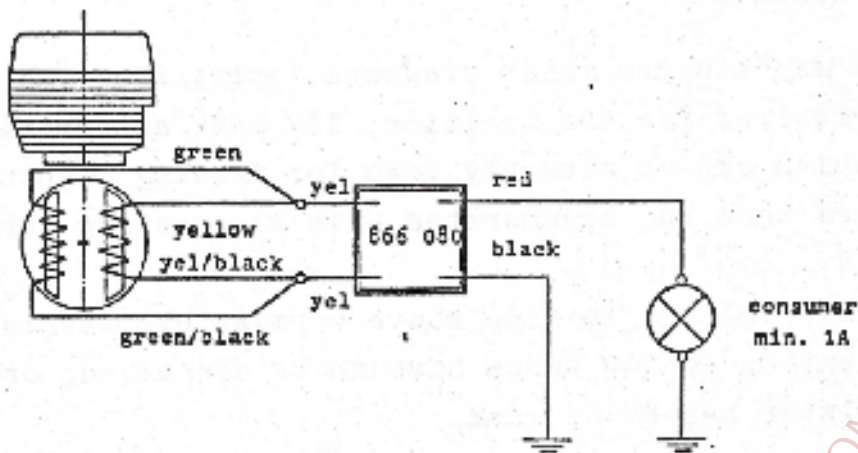

WIRING DIAGRAM FOR RECTIFIER-REGULATOR 866 080

in conjunction with a battery

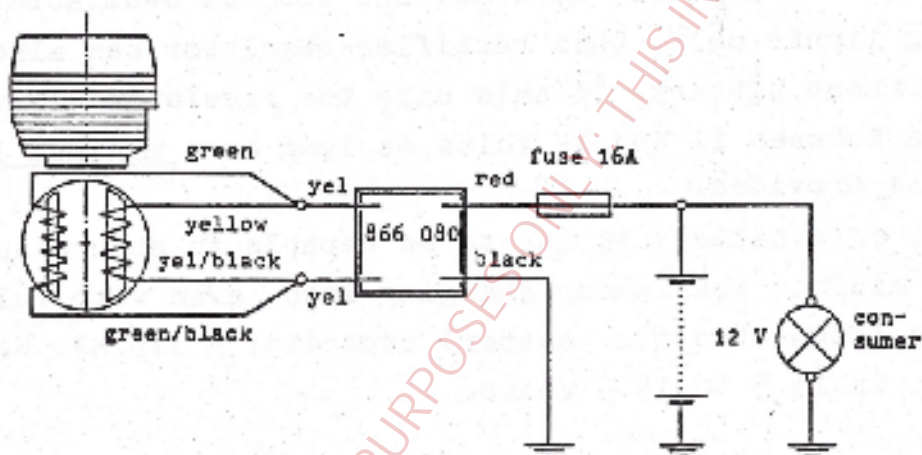

WIRING DIAGRAM FOR ELECTRIC STARTER

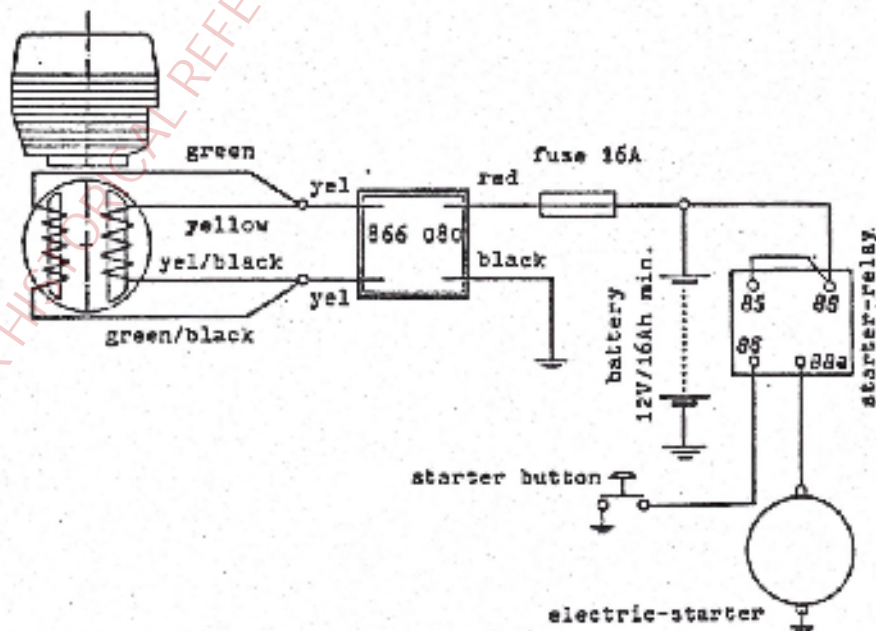

WIRING DIAGRAM FOR RECTIFIER-REGULATOR 264 870
(not limited to minimum of 1 Ampere consumption)

WIRING DIAGRAM FOR RECTIFIER-regulator 264 870
in a circuit without battery

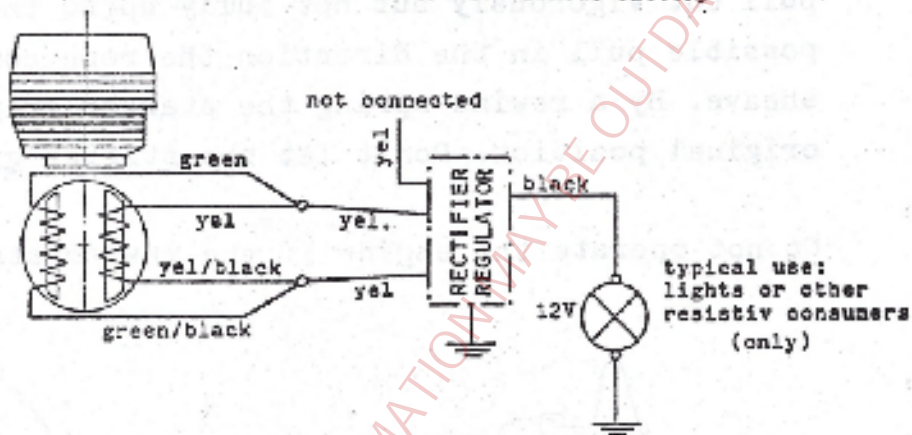

WIRING DIAGRAM FOR RECTIFIER-regulator 264 870
(in conjunction with a condenser 2000 μ F)

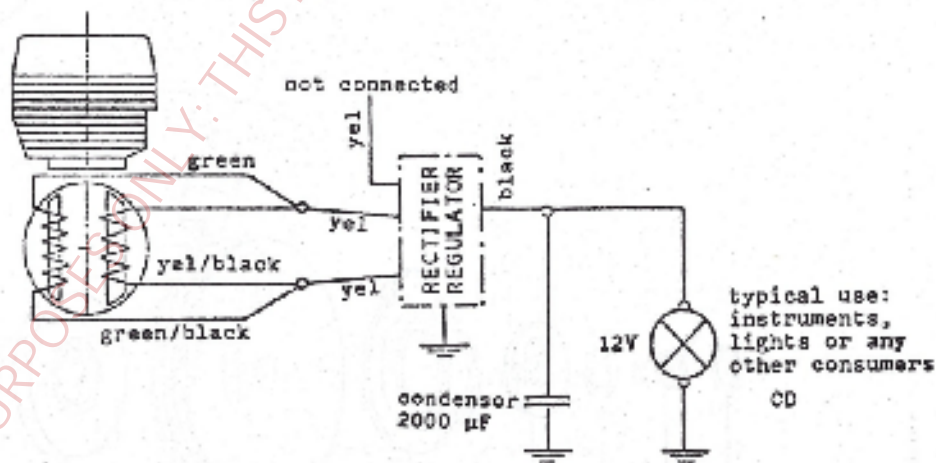

WIRING DIAGRAM FOR RECTIFIER-REGULATOR 264 870
in conjunction with a battery

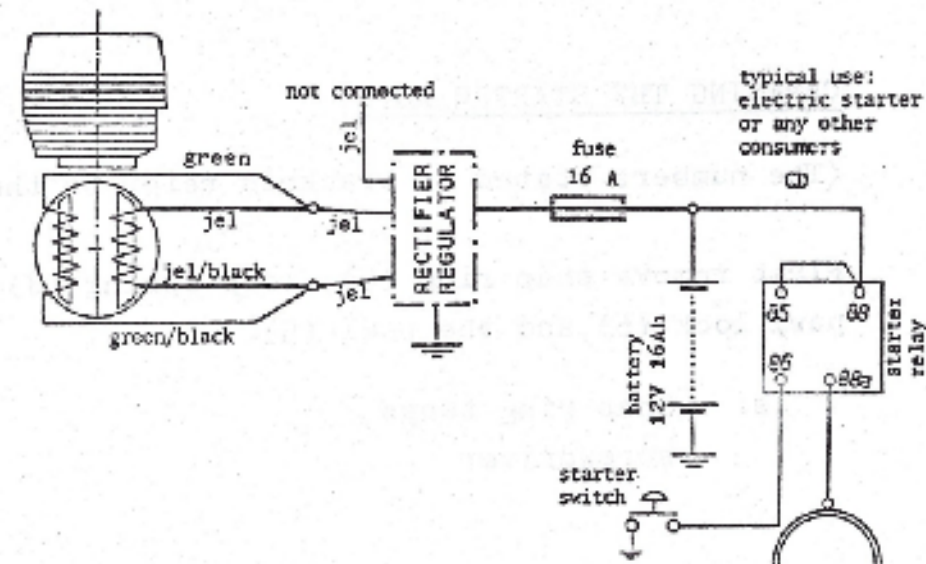

REWIND STARTER

Pull starter grip out slowly until resistance is felt, then pull out vigorously but not fully up to the end. As far as possible pull in the direction the rope comes out of the sheave. By a rewind spring the starter grip returns to its original position. Don't let the starter grip fly back.

Do not operate the engine if the rewind starter is defective.

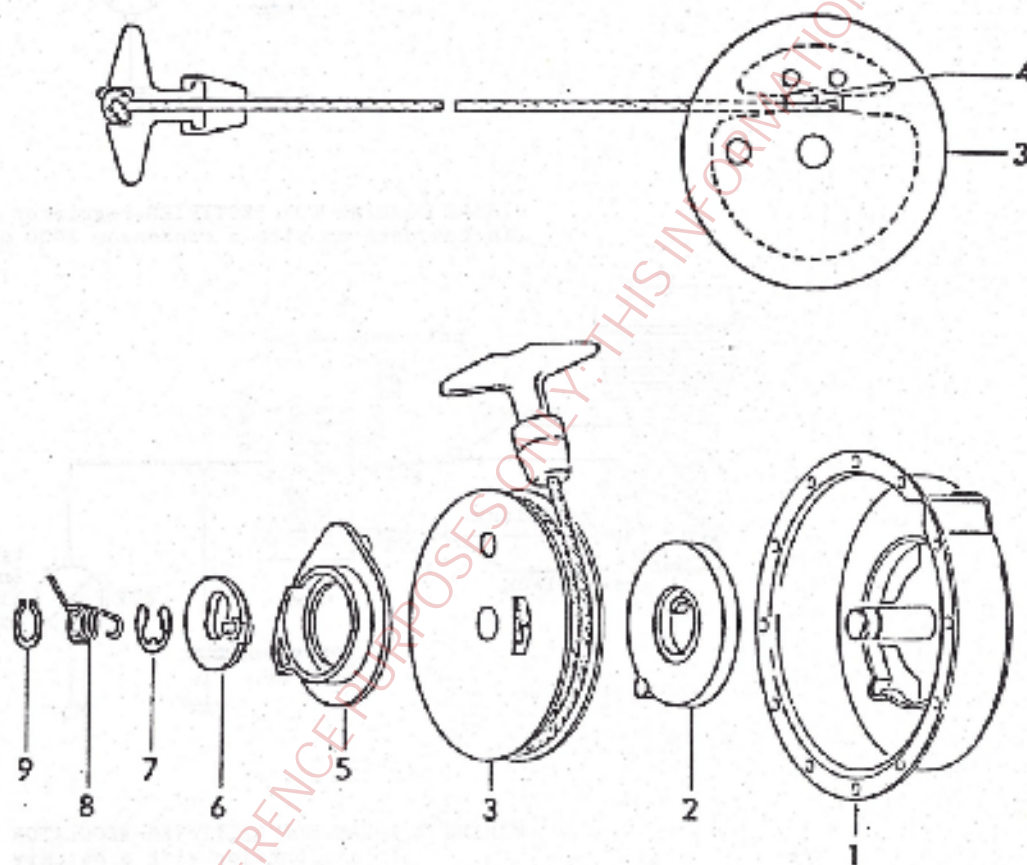

CHANGING THE STARTER ROPE

(The numbers stated in brackets refer to the illustration)

First remove snap ring (9), loop spring (8), circlip (7), pawl lock (6) and the pawl (5).

Tools: Snap ring tongs
screwdriver

Pull out the starter rope fully to the end, hold starter housing (1) and rope sheave (3) together in their position. There is an opening in the rope sheave. The key clamp (4) visible in the opening has to be pushed out in the opposite sense of the pulling direction. Pull the rope out of the rope sheave.

Then insert the new starter rope into the rope sheave, mount the key clamp in the same position as it was before and remount the parts 5, 6, 7, 8 and 9.

Caution! Do not remove spring container (2), this might cause injuries!

FOR HISTORICAL REFERENCE PURPOSES ONLY: THIS INFORMATION MAY BE OUTDATED

DECARBONIZING

After approx. 50 hours of use the combustion chamber should be de-carbonized.

To do so:

Remove cylinder head. Hold cylinders in place by suitable means. Using a scraper, the carbon scales on the combustion chamber of the cylinder head and on the top of the piston should be removed. Piston at top dead center.

MAIN TORQUING SPECIFICATIONS

	<u>Nm</u>	<u>in.lb</u>
Cylinder head nuts M8	18 ÷ 24	160 ÷ 210
Crankcase screws M6	8 ÷ 10	70 ÷ 88
M8	18 ÷ 24	160 ÷ 210
Magneto housing nut (M22 x 1,5)	80 + 90	710 ÷ 800
Crankcase nuts (or -screws) M10	36 ÷ 40	320 ÷ 354
Exhaust manifold screws M8	18 + 24	160 ÷ 210

FOR HISTORICAL REFERENCE PURPOSES ONLY: THIS INFORMATION MAY BE OUTDATED!

FOR HISTORICAL REFERENCE PURPOSES ONLY: THIS INFORMATION MAY BE OUTDATED!

FAULT-TRACING SCHEDULE

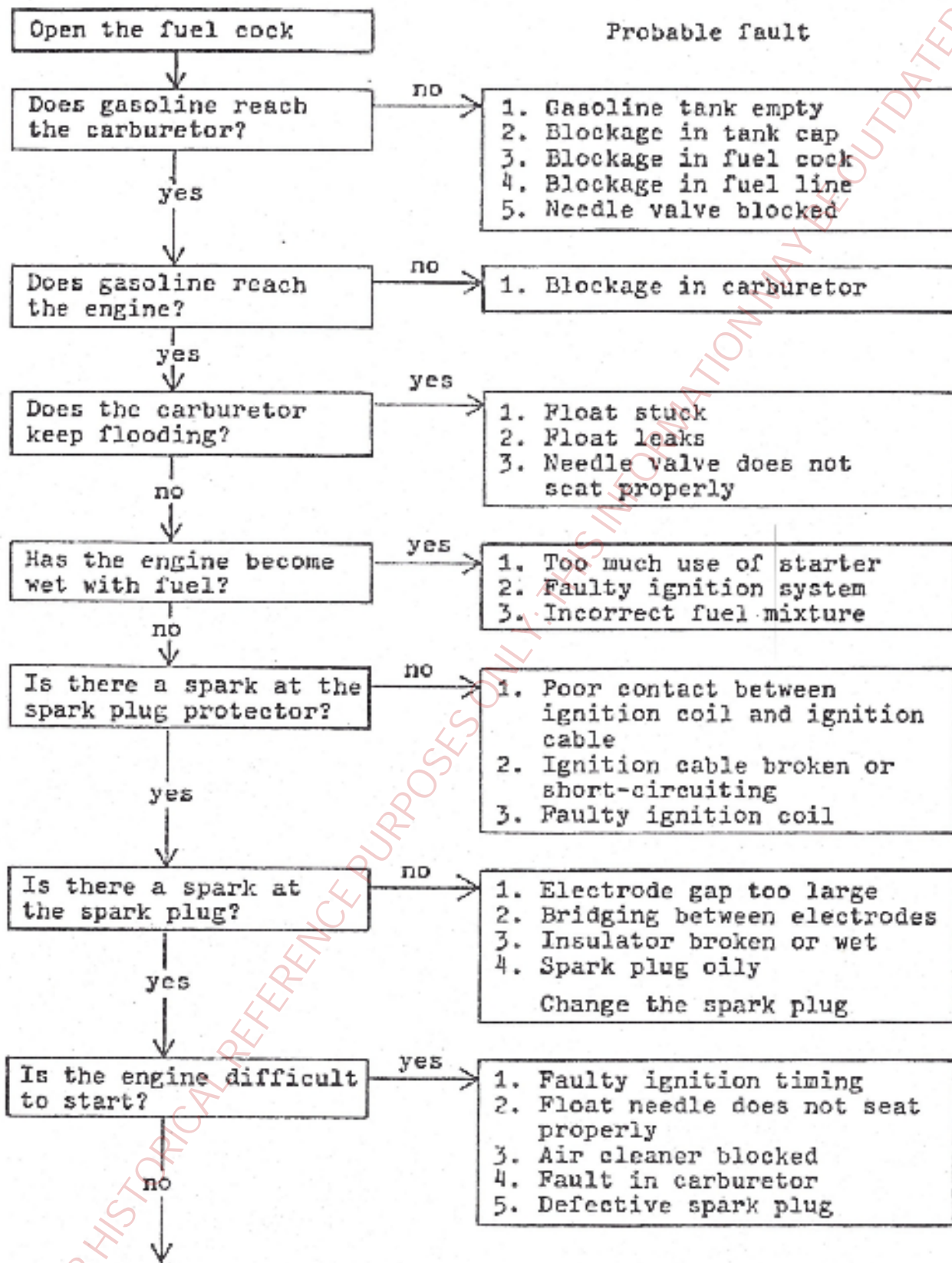

FOR HISTORICAL REFERENCE PURPOSES ONLY. SIMILAR INFORMATION MAY BE OUTDATED!

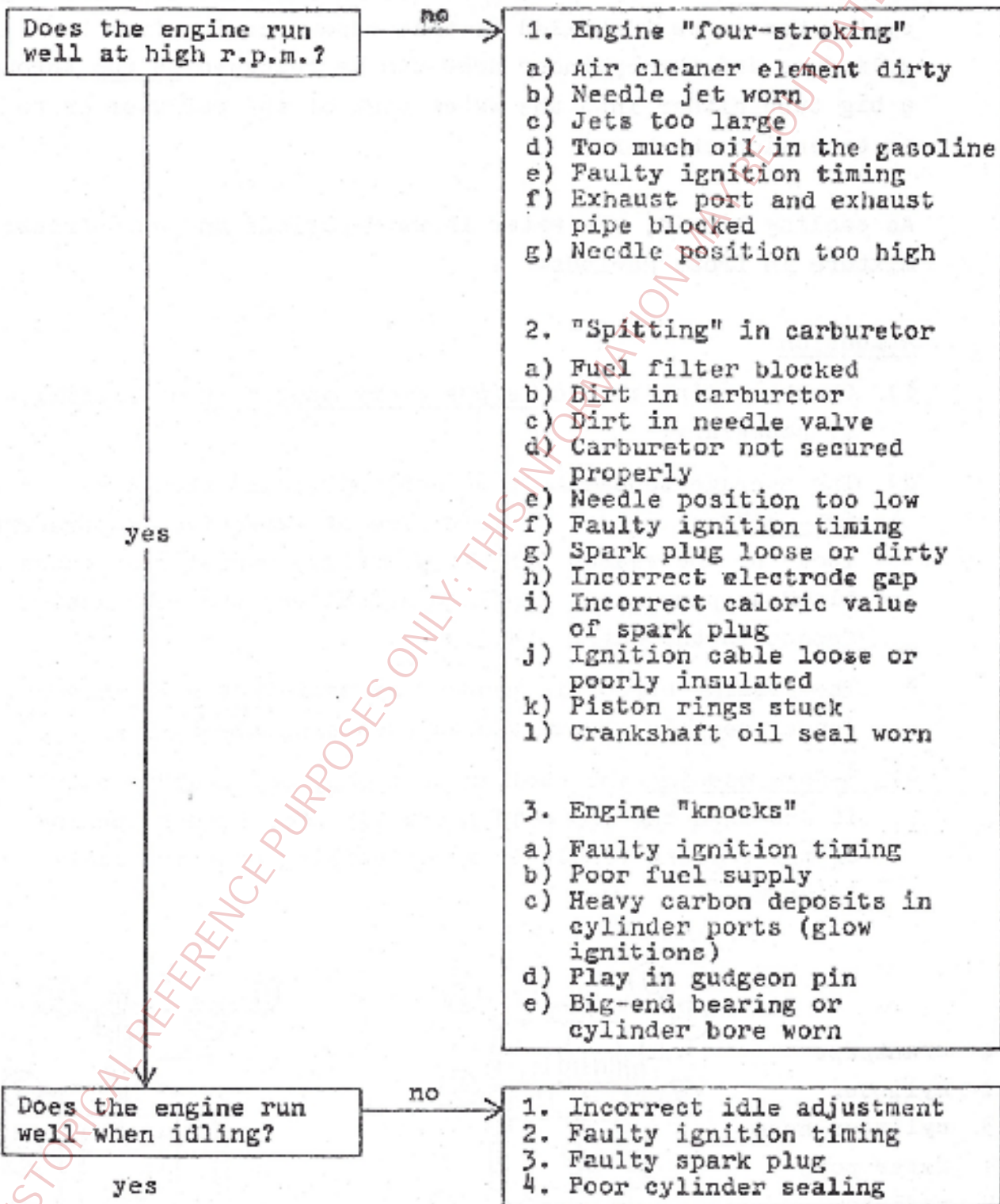

Now all should be well, but remember to work in a methodical sequence when tracing faults.

FOR HISTORICAL REFERENCE PURPOSES ONLY: THIS INFORMATION IS UNCLASSIFIED

LIQUID - COOLING SYSTEM

The cooling liquid is supplied by a pump through the cylinders and the cylinder head to the radiator. The cooling system has to be installed so that vapour coming from the cylinders and the cylinder head can be released to top through a big tube either into the water tank of the radiator or to an expansion chamber.

As cooling liquid, use water in warm periods and anti-freeze mixture in frost periods.

Attention

- 1) Check cooling liquid before every operation and refill, if necessary.
- 2) The average temperature of cooling liquid should be 60 - 80°C. In case of excessive temperature, look for the reason (liquid quantity, radiator or tubes blocked, pump resp. impeller defective, too much anti-freeze in the water etc.).
- 3) The cooling effect is reduced by anti-freeze additives (under certain circumstances even considerably).
- 4) Before opening the cooling tank cap, put a cloth over it and turn the cap only partially off. Sudden opening of the cap can result in water boiling over and scald injuries.

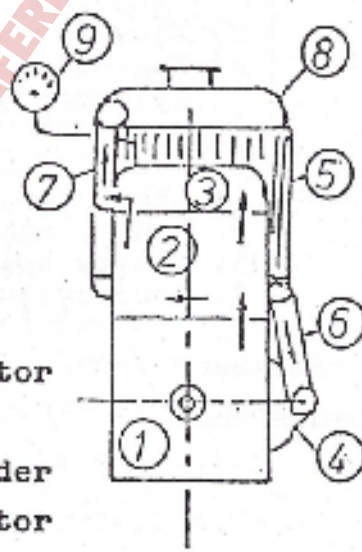
- 
- 1 crankcase
 - 2 cylinder
 - 3 cylinder head
 - 4 water pump
 - 5 radiator
 - 6 tube from radiator to engine
 - 7 tube from cylinder head to radiator
 - 8 expansion chamber
 - 9 temperature gauge for cooling water

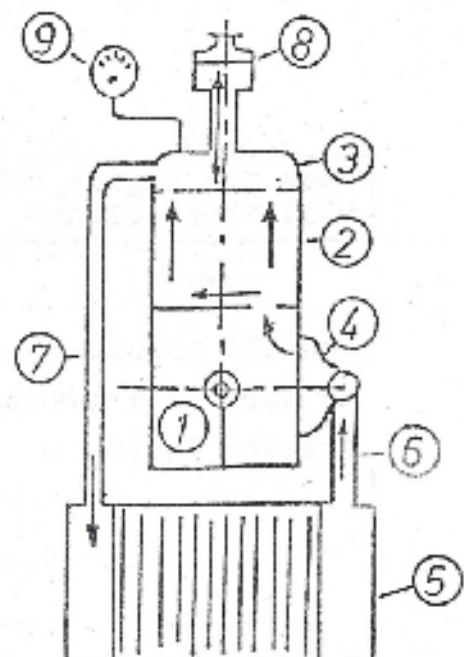

GEAR FOR ROTARY VALVE AND LIQUID-COOLING PUMP

In the center of the crankcase there is a 90° gear with oil lubrication.

Use 2-stroke motor-oil for the rotary valve gear (as used for 2-stroke fuel mixture).

An oil tube leads from the oil tank to the top side of the gear, and a return line from crankcase, bottom, leads back to the tank (see illustration).

Before every operation check the oil level (approx. medium height of the oil tank) as well as for tightness and good condition of oil tubes and connections.

In case of notable oil consumption (more than 1 c.c./hour) look for the leak and check the oil seals inside the crankshaft, if necessary.

- 1 rotary valve gear
- 2 oil tank
- 3 inlet tube
- 4 return line
- 5 crankcase
- 6 cylinder

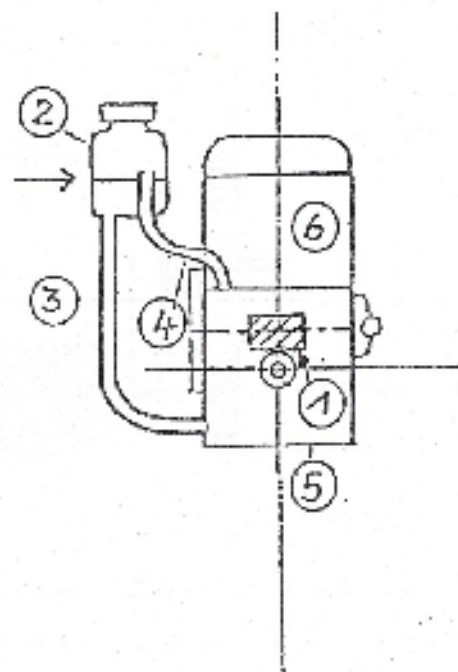

MOUNTING-, MAINTENANCE- AND SAFETY INSTRUCTIONS
for UL - prop gear on ROTAX engine types
377 - 447 - 503 - 462 - 532

1) Put alignment bushing on PTO taper (only on 377 and 447-engines with 3-boss fixation on crankcase).

▲ Clean contact surfaces of adaptor plate and crankcase and moisten contact surfaces between adaptor and gear-housing and screw thread with LOCTITE 221 (light) and apply LOCTITE 648 on contact surfaces of M10 allen-screwhead.

Fit O-ring in O-ring groove of flange plate and fix flange plate.

Torque of M10 bolts: 40 Nm (29,5 ft.lb.)
No lock washer for screws M10 foreseen.

2) Clean and degrease taper of engine PTO shaft carefully with trichloroethylene or equivalent.

Degrease also 1/2" bolt and PTO shaft thread.

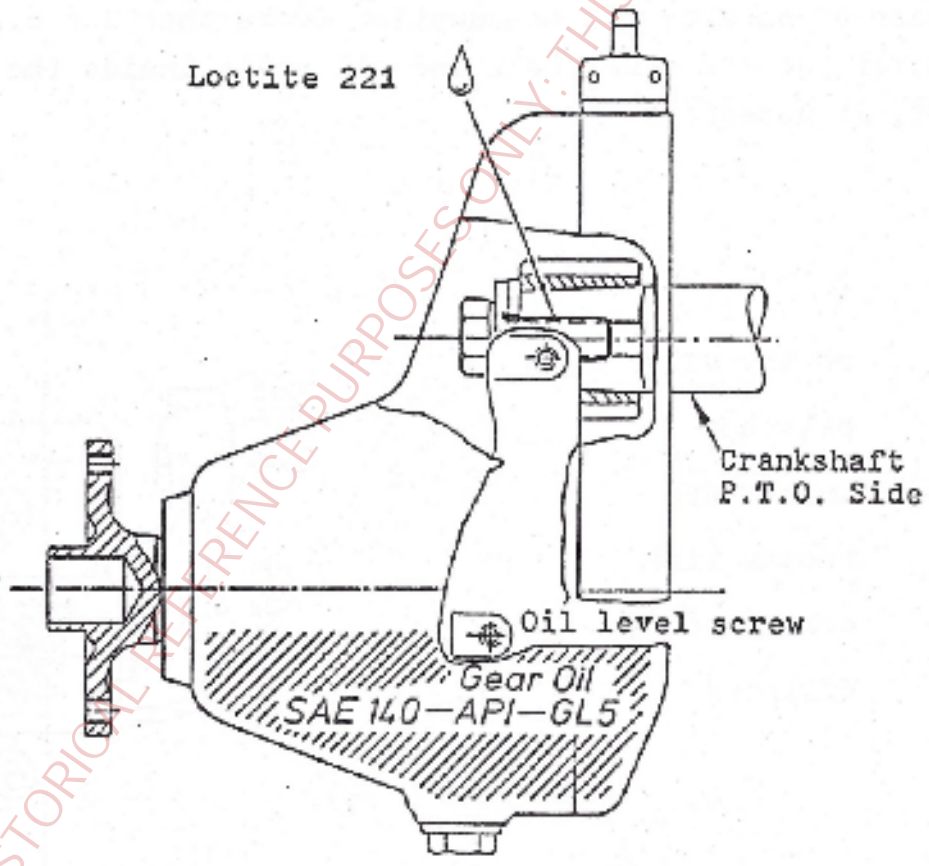

Note: Gear-boxes for above engine types can be mounted alternatively with prop shaft below or above crankshaft axis (see also paragr. 5.)

- ▲ 3) Fix sprocket with 1/2" bolt, washer and lock washer, use Loctite 221 (light) only on thread.

Mount the oil slinger between washer and lock washer.

Torque for 1/2" bolt: 41 ± 45 ft.lb or 55 ± 60 Nm

- ▲ 4) Bolt gear assy with studs, lock washer and O-ring on flange plate.

Torque for studs M8 5 - 6 ft.lb or 7 - 8 Nm

Torque for nuts M8 15 - 18 ft.lb or 20 - 24 Nm

- ▲ 5) Inspect correct position of oil drain plug (bottom) and vent plug (top).
Secure drain plug with wire.

- ▲ 6) Only applicable for execution with separate prop flange:

Degrease gear PTO shaft, thread and bolt M12 x 1,5 LH (left hand).

Mount propeller hub with Loctite (light) on taper and thread.

Torque: 41 ± 45 ft.lb or 55 ± 60 Nm

Attention: left hand thread

- 7) Prop hub is for 6 x 1/4" bolts (or 6 x M8), no bolts supplied by Rotax.

- ▲ 8) Fill gear oil SAE 90-API-GL 3 into gear-box (for both directions of prop. shaft - above and below crankshaft axis) up to lower oil level plug.
Secure vent plug with wire.

- ▲ 9) Preflight Instructions

Attention:

As supplied by the factory, irrespective whether gear-box is loose or mounted on engine, there is no oil filled into the gear-box.

Fill in oil. Secure drain plug, vent plug and oil level screws with wire before use!

Check tightness of mounting bolts and nuts.

- ▲ 10) Maintenance (every 10 operating hours)

Check oil volume on respective oil level screw and secure again with wire.

Change oil after 1st 10 hours of operation.

Change oil every 100 hours or every 2 years (which occurs first).

Check if propeller tip clearance is as usual.

- ▲ 11) Safety

Safety is everyone's business. Help to assure secure and troublefree operation by observing the above instructions.

In case of doubt contact your authorized workshop.

- ▲ 12) Mounting and maintenance operations must be done only by skilled personnel.

- ▲ 13) Safety warning symbol ▲ : Failure to obey a safety warning may result in injury to you or others.



1) Different rotary valves and adjustments are in use:

- 1.1. Part no. 924 202 for silent, low performance (German) execution. For identification please check angle $\alpha = 117^\circ$ and $\beta = 40^\circ$.
- 1.2. Part no. 924 205 for high performance (USA) execution. For identification please check angle $\alpha = 147^\circ$ and $\beta = 51^\circ$.

2) Installation:

To correctly install the rotary valve disc proceed as follows:

- Turning crankshaft counter-clockwise (drive pulley side), bring magneto side piston to Top Dead Center using a T.D.C. gauge.
- Position the rotary valve disc on gear to have edges as close as possible to the marks.

NOTE: The rotary valve disc is asymmetrical, therefore, at assembly try positioning each side of disc on gear to determine best installation position.

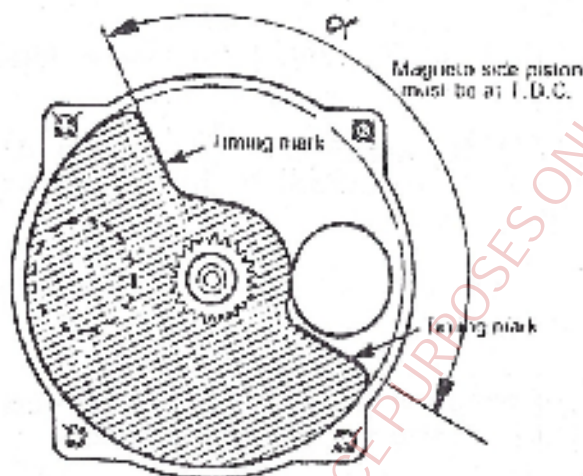

3) Marking:

From top edge of magneto side inlet port, mark crankcase at β

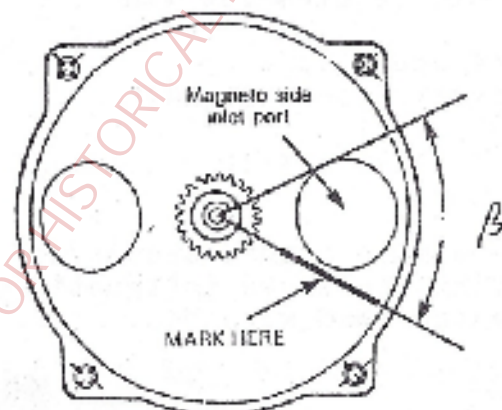

TECHNICAL DATA

ROTAX ENGINE TYPE 462 UL

Configuration 36.462.08/18 extra-silent version
 36.462.09/19 standard version

Description: Two-cycle, two-cylinder rotary valve engine, oil-in-fuel lubrication, liquid-cooled, with integrated water pump

Bore: 69,5 mm (2,736 in.)

Stroke: 61,0 mm (2,401 in.)

Displacement: 462,0 c.c. (28,242 cu.in.)

Compression ratio: theoretical 11,5
 effective 6,7

Power output: 28 kW (38 hp) at 5500 rpm (low performance version = extra silent version), performance sheet Lb 278
 38 kW (52 hp) at 6500 rpm (Standard version), performance sheet Lb. 278

Torque max.: 52 Nm (38 ft-lb.) at 5250 rpm, performance sheet Lb 278
 56 Nm (40 ft-lb.) at 6000 rpm, performance sheet Lb 278

Max. recommended rpm: 5800 1/min.
 6800 1/min.

Direction of rotation: counter-clockwise, viewed towards p.t.o. (without reduction gear-box)

Cylinder: 2 light alloy cylinders with cast iron sleeve

Piston: Aluminum cast piston with 2 piston rings

Piston/cylinder clearance: 0.08 - 0.09 mm (0.00315 - 0.00354 in.)

Ignition system: flywheel magneto generator SCP2 with contact breakers

Generator output: AC 12V 110W + 30W

Rectifier-regulator optional: a) 866 080 requires minimum load 12 W (1 Amp.) to regulate
 b) 264 870 - no minimum load required

Ignition timing: 1,86 mm = 0,0732 in. (18 degrees) B.T.D.C.

Contact breaker points gap: 0,3 mm - 0,4 mm (0,0118 - 0,0157 in.)

Break-away gap: 13 - 17 mm (0,512 - 0,67 in.)

Spark plug: 12 mm (0,472 in.) B8ES

Electrode gap: 0.5 mm (0.02 in.)

Radio frequency interference suppression: optional for AC or DC

Rotary valve: Low performance version: 924 202 section angle 117 degrees
Standard version: 924 205 147 degrees

Rotary valve timing: Low performance version:
rotary valve opens: 120 degrees B.T.D.C.
rotary valve closes: 40 degrees A.T.D.C.
Standard version:
rotary valve opens: 140 degrees B.T.D.C.
rotary valve closes: 51 degrees A.T.D.C.
measured on crankcase openings, +/- 4 deg. tolerance

Carburetor: 1 x BING 36 mm (1.417 in.), hand lever or cable choke

Fuel pump: pneumatic fuel pump DF 52

Fuel: regular Gasoline, octane number not below MON 83 or RON 90 (unleaded allowed)

Lubrication of engine: SUPER 2-stroke oil (for high performance air cooled 2-cycle engines, proposed ASTM/CEC standard TSC3) mixing ratio 1 : 50 (2 per cent)

Starter: Rewind starter optional:
a) Rewind starter with electric starter, p.t.o. side (for engine without reduction gearbox) or
b) electric starter, magneto side without rewind starter (gear-box is possible)

Reduction gear-box, optional: Reduction gearbox with torsional shock absorber, ratios available: 1 = 2,0 / 2,24 / 2,58 / 3,8
1 = 3,0 for extra silent version only and supplied only installed on engine.

Lubrication of gearbox: Gear oil SAE 140, API-GL5 or GL6

Direction of prop. shaft: clockwise, viewed towards propeller flange

Cooling: liquid-cooled optional: a) 2 radiators kit integrated 0.6 l.=0.159 gal.US (cooling system 2,3 l. = 0.608 gal.US)
b) 1 radiator 0.8 lit. (0.211 gal.US)

Weights: Engine without carburetor, exhaust system, intake silencer, radiator, fuel pump 26,00 kg (57,32 lb.)

Additional weights: Carburetor with rubber flange and clamps: 8,90 kg (1,98 lb.)
Exhaust system assy. approx. 3,90 kg (8,60 lb.)
Intake silencer with air filter 0,84 kg (1,85 lb.)
integrated radiator kit approx. 2,10 kg (4,63 lb.)
Electric starter kit, p.t.o. side 3,42 kg (7,54 lb.)
Electric starter kit, magneto side 3,50 kg (6,61 lb.)
Reduction gearbox, dry 4,50 kg (9,92 lb.)

FOR HISTORICAL REFERENCE PURPOSES ONLY: THIS INFORMATION MAY BE OUTDATED!

ENGINE TYPE: _____

SERIAL NO.: _____

PURCHASE DATE: _____

INSTALLATION IN: _____

DEALER IMPRINT AREA

FOR HISTORICAL REFERENCE PURPOSES ONLY: THIS INFORMATION MAY BE OUTDATED!



BOMBARDIER-ROTAX GMBH

MOTORENFABRIK

A-4623 Gunskirchen - Austria

Telefon: (07246) 271-0*, Telex: 25546 brgk a

Telegrammadresse: Bombrotax Gunskirchen