

Tyre Databook

2020 - 2021

Car | 4 x 4 | Van



This data book contains comprehensive information on our car, 4x4, LT (light truck) and van tyres.

Unless not otherwise specified, the instructions and data given in this data book are valid for all tyre brands of Continental AG.

Instructions and data exclusively valid for Continental or other single tyre brands are specially marked or displayed on separate pages.

Tyre safety tips

The technical data and other details on tyres and accessories have been compiled to reflect as exactly and completely as possible the current state of development and are based on **ETRTO¹⁾**, **ISO²⁾**, **WdK** and **DIN³⁾** standards.

Most of the tyres of Continental AG comply with **DOT⁴⁾** regulations and are marked accordingly.

They are homologated in accordance with the relevant **UN / ECE⁵⁾** regulation (ZR tyres without service description in accordance with EU guideline 92/23).

This databook is intended for information and instruction only. No liability whatsoever will be accepted for damage, regardless of its nature and its legal basis, arising from advice given in this book.

We recommend that the **inflation pressure** of every tyre is **checked** and adjusted at least **every 14 days**. This does also apply for vehicles equipped with a tyre pressure monitoring system (TPMS). Avoid driving over sharp-edged or pointed objects.

Lower inflation pressures, greater loads or higher speeds than specified by the vehicle and / or tyre manufacturer all shorten the **service life** of tyres and can result in structural damages.

We recommend that **new tyres** are **run in** at moderate speeds for the first 125 to 190 miles (200 to 300 km) to roughen the tread surface. The tyre does not achieve its best performance until after this running-in period.

We recommend all wheel positions are fitted with tyres of the **same tread pattern**.

It is especially important that SSR runflat tyres*) are not mixed with standard tyres.

Please observe the detailed operating instructions on page 109 ff.



SAFETY WARNING!

The instructions given in this databook must be observed to ensure vehicle safety at all times.

This applies especially with respect to tyre inflation pressure recommendations. **Non-compliance with these instructions means risking tyre damage which, if serious enough, may result in a tyre bursting. It is hazards like these that can cause traffic accidents involving vehicle damage and / or serious personal injury.**

¹⁾ ETRTO - The European Tyre and Rim Technical Organisation, Brussels

²⁾ ISO - International Organization for Standardization

³⁾ DIN - German Institute for Standardisation, Berlin
WdK - German Rubber Manufacturers' Association, Frankfurt / M.

⁴⁾ DOT - Department of Transportation (USA)

⁵⁾ UN / ECE - Economic Commission for Europe (UNO-Institution, Geneva)

*) only available for tyre brand Continental and Uniroyal
See page 23 for further details

The content of this publication is provided for information only and without responsibility. Continental AG makes no representations about the accuracy, reliability, completeness or timeliness of the information in this publication. Continental AG may, in its sole discretion, revise the information contained herein at any time without notice.

Continental AG's obligations and responsibilities regarding its products are governed solely by the agreements under which they are sold. Unless otherwise agreed in writing, the information contained herein does not become part of these agreements. This publication does not contain any guarantee or agreed quality of Continental AG's products or any warranty of merchantability, fitness for a particular purpose and non-infringement. Continental AG may make changes in the products or services described at any time without notice.

This publication is provided on an "as is" basis. To the extent permitted by law, Continental AG makes no warranty, express or implied, and assumes no liability in connection with the use of the information contained in this publication. Continental AG is not liable for any direct, indirect, incidental, consequential or punitive damages arising out of the use of this publication. Information contained herein is not intended to announce product availability anywhere in the world.

The trademarks, service marks and logos (the Trademarks) displayed in this publication are the property of Continental and / or its affiliates. Nothing in this publication should be construed as granting any license or right to the Trademarks. Without the express written consent of Continental AG the use of the Trademarks is prohibited.

All text, images, graphics and other materials in this publication are subject to the copyright and other intellectual property rights of Continental AG and / or its affiliates. Continental AG owns the copyrights in the selection, coordination and arrangement of the materials in this publication. These materials may not be modified or copied for commercial use or distribution.

Copyright © 2020 Continental AG
All rights reserved.

TD C 10/2020

Introduction, Safety hints	2
Publisher's imprint	4
Tyre Sidewall Information	6
Service description (including Load Index and Speed Symbol)	8
Units of measurement and definitions of the technical data	9

Passenger car tyres

Continental brand tread patterns and recommended applications

- Passenger / SUV summer tyres	10
- Passenger / SUV winter tyres	18
- Allseason tyre	22

Tyre Technologies

- SSR runflat tyres	23
- ContiSeal™ tyres	24
- ContiSilent™ technology	25

Tyre Data of all tyre brands of Continental

- Passenger / SUV, 4 x 4	26
- LT, 4 x 4	66
Special spare tyres	72
Conti Sealant kits and replacement	76

Van tyres

Continental brand tread patterns and recommended applications	78
Technical data of all tyre brands of Continental	84

Tyres for caravans and car drawn trailers (special load capacities)	96
Car rims	105

Operating instructions

Correct choice of tyre and wheel	109
Winter tyres	109
Tread rubber brittleness influenced by temperature	110
Fitting the tyre	110
Fitting the wheel to the vehicle	112
Tyre pressure	112
Load capacity and speed	117
Tyre damage	119
Tyre rotation on a vehicle	119
Tyre storage	121
Tyre repair	123
Tyre service life for passenger car and light truck	125
Minimum tread depth	126
Guidelines on tyre safety	127

Index	128
Service	130

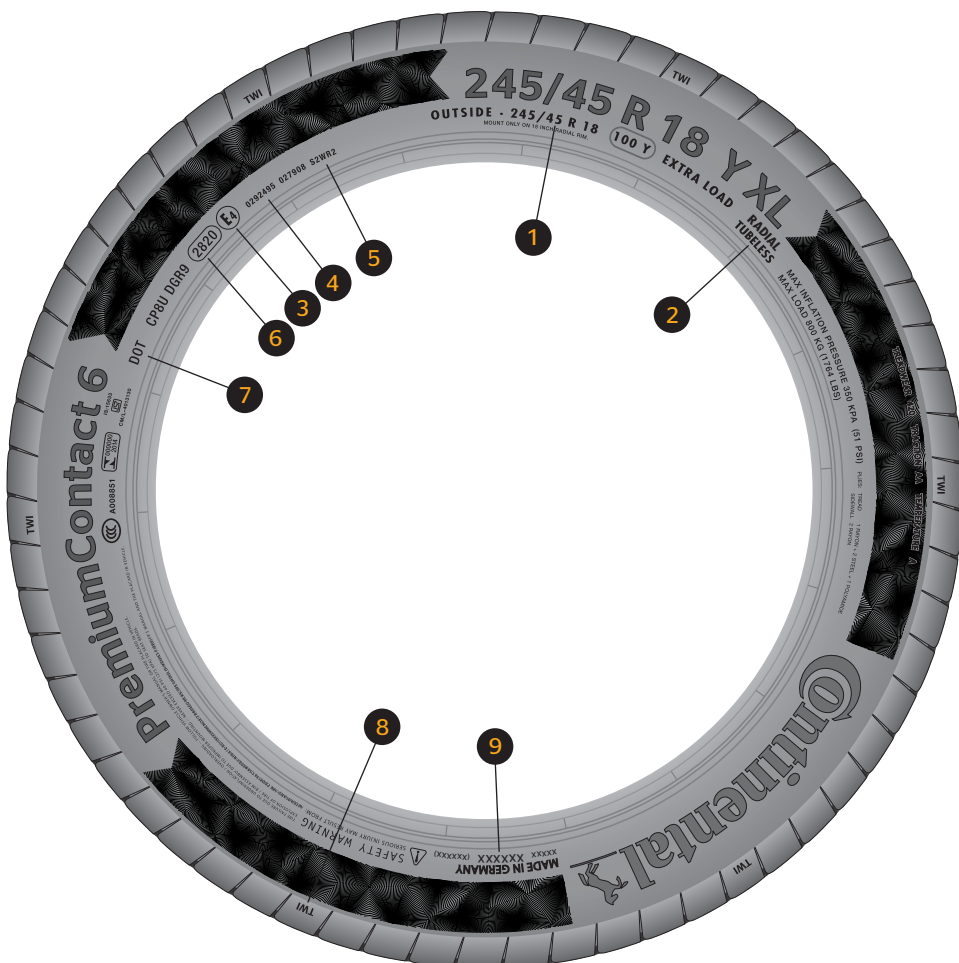

Example data for PremiumContact 6 (tyre brand Continental). The specifications on a tyre sidewall are standardised and apply for other tyre brands accordingly.

- 1** **245/45 R 18 100 Y XL** 245 Nominal section width in mm.
45 Nominal aspect ratio (Tyre height is 45 % of tyre width).
R Symbol for radial tyre (or RF for run flat tyres).
18 Rim diameter code.
100 Load Index "100" = max. load of this tyre is 800 kg (see table page 8).
Y Speed Symbol, indicating max. speed: Y=300 km/h / 187 mph (see table page 8).
Other information may be added after the size marking:
XL Extra Load, reinforced tyre for increased load capacity (new: XL+ for especially high load capacity)

Divergent designation of inch sizes (LT) see page 9, graph at the bottom (centre).

- 2** **TUBELESS** tubeless. (TUBE TYPE tyres must be mounted with tubes).
- 3** **E 4** Marking indicating accordance with UN regulations. The number after the E in the circle indicates the country of homologation. (E⁴) (4=Netherlands).
- 4** **0292495** Approval number acc. to relevant UN regulation.
- 5** **S2WR2** The string "S2WR2" indicates compliance with maximum permissible sound value S2, max. wet grip value and max. value of rolling resistance R2.
- 6** **2820** Production code ("28" means 28th week, "20" means 2020).
- 7** **DOT** DOT = Department of Transportation, USA.
- 8** **TWI** TWI = Tread Wear Indicator. Cross ribs evenly spaced around the circumference of the tyre in the longitudinal tread grooves and becoming level with the tread surface when the remaining tread depth is down to 1.6 mm.
- 9** **Made in ...** Marking showing the country of origin.

Other possible markings on the sidewall

M+S

'Snow tyre' means a tyre whose tread pattern, tread compound or structure is primarily designed to perform better in snow conditions than a normal tyre with regard to its ability to initiate or maintain vehicle motion.



The Alpine symbol identifies winter tyres according to UN regulations (valid in the EU and various other countries) and the tyre regulations of the USA and Canada. The snow performance of these winter tyres has to be proven by objective tests and meet or exceed defined limits. These tyres provide high performance with regards to safety and control on snow, on icy roads and in general at low temperatures.

Including Load Index and Speed Index

Load Index (LI)

The Load Index is a numerical code associated with the maximum load a tyre can carry (see also page 113).

LI	kg	LI	kg	LI	kg	LI	kg	LI	kg
50	190	66	300	82	475	98	750	114	1180
51	195	67	307	83	487	99	775	115	1215
52	200	68	315	84	500	100	800	116	1250
53	206	69	325	85	515	101	825	117	1285
54	212	70	335	86	530	102	850	118	1320
55	218	71	345	87	545	103	875	119	1360
56	224	72	355	88	560	104	900	120	1400
57	230	73	365	89	580	105	925	121	1450
58	236	74	375	90	600	106	950	122	1500
59	243	75	387	91	615	107	975	123	1550
60	250	76	400	92	630	108	1000	124	1600
61	257	77	412	93	650	109	1030	125	1650
62	265	78	425	94	670	110	1060	126	1700
63	272	79	437	95	690	111	1090	128	1800
64	280	80	450	96	710	112	1120	131	1950
65	290	81	462	97	730	113	1150		

Speed Symbol (SSY)

The Speed Symbol indicates the maximum speed at which the tyre can carry a load corresponding to its Load Index.

SI	Max. speed for passenger car tyres		SI	Reference speed for commercial vehicle tyres	
M	81 mph ¹⁾	130 km/h ¹⁾	K	69 mph	110 km/h
P	93 mph	150 km/h	L	75 mph	120 km/h
Q	100 mph	160 km/h	M	81 mph	130 km/h
R	106 mph	170 km/h	N	87 mph	140 km/h
S	112 mph	180 km/h	P	93 mph	150 km/h
T	118 mph	190 km/h	Q	100 mph	160 km/h
H	130 mph	210 km/h	R	106 mph	170 km/h
V	150 mph	240 km/h	S	112 mph	180 km/h
W	169 mph	270 km/h	T	118 mph	190 km/h
Y	187 mph	300 km/h	H	130 mph	210 km/h
(...Y)	over 187 mph ²⁾	over 300 km/h ²⁾			
(ZR*)	over 150 mph	over 240 km/h			

¹⁾ As a rule only used for special spare tyres if they qualify according to UN Regulation 30. In accordance with UN Regulation 64 governing the use of special spare tyres, even higher speed rated tyres may only be used up to a maximum speed of 50 mph (80 km/h).

²⁾ See page 118, table 4 for details.

* Obsolete designation, production until Nov., 2014.

Tyre size designations **A** as well as the technical data in the tables do comply with international standards.

All **dimensions** are given in millimeters (mm), if not indicated in a different way.

The **rim width** **B** and **diameter** are given in inch code. (Tyre ranges on new rim types may also be marked in mm.)

The **load capacity** **C** is indicated in kilograms (kg).

Construction measurements are theoretical values for the design of the tyre: The width is relative to the smooth sidewall, the outer diameter to the tread centre.

Maximum measurements **D** are actual **operating measurements** of the inflated tyre (operating pressure) in the unloaded state. They include growth but exclude dynamic distortions. The max. measurements are binding for vehicle designers.

Vehicle designers should bear in mind the maximum values for tyre outer diameter and width when planning the wheel space of a vehicle, if all standard approved tyres are to fit without any restrictions.

The **width** **E** is the max. permitted tyre width, including sidewall decorative markings, when the tyre is mounted on the correct rim.

The **outer diameter** **F** is the max. permitted diameter.

The **static radius** **G** is the distance between the wheel centre and the ground contact patch under max. load at the recommended tyre pressure.

The **rolling circumference** **H** is the distance covered by a point on the circumference when the tyre revolves once at 60 km/h (37 mph).

Size	Tyre A		Permitted rims ¹⁾ B (measuring rim bold)	Tyre dimensions D Max. standard value in operation ²⁾		Radius G stat. +/- 2% (mm)	Rolling circumference ³⁾ H + 1.5% - 2.5% (mm)
	Load Index LI	Load capacity C kg		E Width (mm)	Outer-Ø F (mm)		

(Display of these measurement specs in the table headers of this Databook, here example of passenger and SUV tyres - p. 26 ff.)

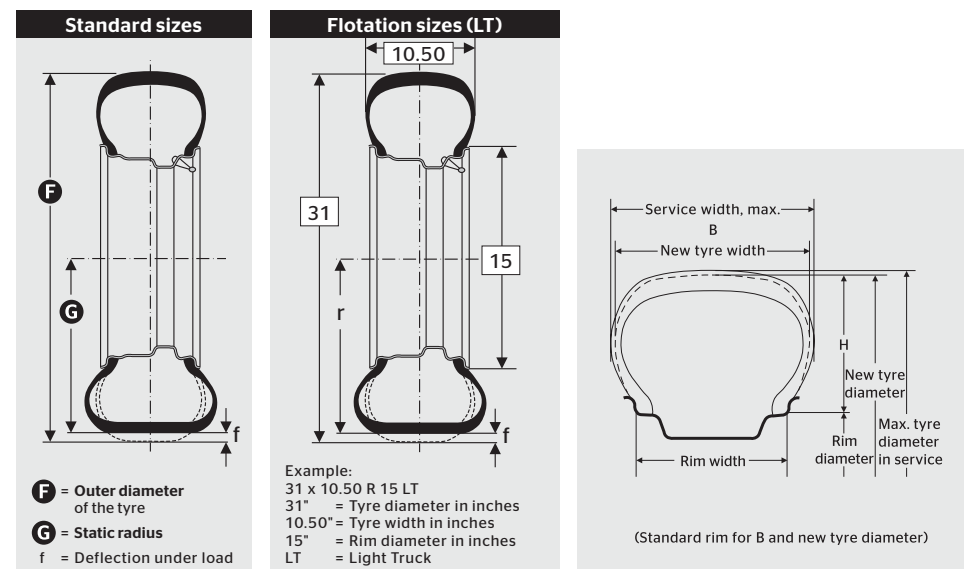

Passenger- and SUV Summer tyres

SportContact™ 6

Designed for sports and high-performance vehicles

- › Maximum control for absolute steering precision
- › Maximum stability at high speeds
- › Maximum grip for short braking distances
- › Asymmetrical non-directional tread pattern

Tyre dimensions*

Tyre width in mm	225-335
Rim size in inches	18-24
Speed Symbol	Y / (Y)
Tyre cross-section	series 25-50

Also available as SSR runflat tyre and with noise reducing ContiSilent™ technology. See page 23 / 25 for further details.



ContiSportContact™ 5 P

Designed for sports and high-performance vehicles

- › Perfect steering precision and sporty handling
- › Outstanding grip and stability during cornering
- › Optimised rolling resistance thanks to 'Cap and Base' tread
- › Asymmetrical non-directional tread pattern

Tyre dimensions*

Tyre width in mm	225-325
Rim size in inches	18-22
Speed Symbol	Y / (Y)
Tyre cross-section	series 30-45

Also available as SSR runflat tyre and with noise reducing ContiSilent™ technology. See page 23 / 25 for further details.



ContiSportContact™ 5

For high-performance and luxury vehicles

- › Excellent road grip and safety when cornering
- › Shorter braking distances in all weather conditions
- › Reduced fuel consumption and high mileage
- › Asymmetrical non-directional tread pattern

Tyre dimensions*

Tyre width in mm	195-315
Rim size in inches	17-22
Speed Symbol	H-Y
Tyre cross-section	series 35-65

Also available as SSR runflat tyre, ContiSeal™ tyre and with noise reducing ContiSilent™ technology. See page 23 - 25 for further details.



PremiumContact™ 6

For mid-sized and executive class vehicles

- › Maximum wet braking while improving mileage due to Safety Silica Compounds
- › Extended driving convenience upgraded by the comfort-optimised performance footprint
- › Sporty driving in every car thanks to handling-optimised pattern design
- › Asymmetrical non-directional tread pattern

Tyre dimensions*

Tyre width in mm	185-325
Rim size in inches	15-22
Speed Symbol	H-Y
Tyre cross-section	series 30-65

Also available as SSR runflat tyre, ContiSeal™ tyre and with noise reducing ContiSilent™ technology. See page 23 - 25 for further details.



Passenger- and SUV Summer tyres

ContiPremiumContact™ 5

For mid-sized and executive class vehicles



- > Perfect grip and optimal handling in every driving situation
- > Short braking distances on dry and wet surfaces
- > Comfortable driving and improved rolling resistance
- > Asymmetrical non-directional tread pattern

Tyre dimensions*

Tyre width in mm	185-235
Rim size in inches	14-17
Speed Symbol	T-Y
Tyre cross-section	series 55-70

Also available as ContiSeal™ tyre.
See page 24 for further details.

EcoContact™ 6

For a wide range of vehicles



- > Maximum fuel efficiency
- > Enhanced mileage
- > Optimised grip and handling experience
- > Due to new Green Chili™ 2.0 compound
- > Asymmetrical non-directional tread pattern

Tyre dimensions*

Tyre width in mm	145-315
Rim size in inches	13-22
Speed Symbol	T-Y
Tyre cross-section	series 30-80

Also available as ContiSeal™ tyre.
See page 24 for further details.

ContiEcoContact™ 5

For compact and mid-sized vehicles



- > Optimised rolling resistance for reduced fuel consumption
- > High braking safety and short braking distances on wet roads
- > Asymmetrical non-directional tread pattern

Tyre dimensions*

Tyre width in mm	165-245
Rim size in inches	14-20
Speed Symbol	T-Y
Tyre cross-section	series 45-70

Also available as SSR runflat tyre and ContiSeal™ tyre.
See page 23 / 24 for further details.

SUV Onroad tyres

CrossContact™ UHP

For sporty SUVs

- > Short braking distances and high cornering stability
- > Safety reserves for outstanding handling and fun at the wheel
- > Low rolling resistance and excellent grip
- > Asymmetrical non-directional tread pattern

Tyre dimensions*

Tyre width in mm	235-305
Rim size in inches	16-23
Speed Symbol	H-Y / (Y)
Tyre cross-section	series 30-65

Also available as SSR runflat tyre and ContiSeal™ tyre.
See page 23 / 24 for further details.



4x4SportContact™

For SUVs and offroad vehicles

- > Good cornering stability
- > Good protection against aquaplaning
- > Suitable for high-speed road use
- > Asymmetrical non-directional tread pattern

Tyre dimensions*

Tyre width in mm	275
Rim size in inches	19-20
Speed Symbol	Y
Tyre cross-section	series 40-45



SUV Allround tyres

ContiCrossContact™ LX 2

For SUVs and offroad vehicles

- > Excellent dry and wet braking performance and very good handling properties
- > High mileage and high level of driving comfort
- > Outstanding traction in light off-road use
- > Non-directional tread pattern

M+S

Tyre dimensions*

Tyre width in mm	205-285
Rim size in inches	15-20
Speed Symbol	S-V
Tyre cross-section	series 50-75



ContiCrossContact™ LX

For SUVs and offroad vehicles

- > Excellent handling and braking performance for on-road and off-road use
- > Good protection against aquaplaning
- > Precise steering response and superb straight-line tracking
- > Asymmetrical non-directional tread pattern

M+S

Tyre dimensions*

Tyre width in mm	215-265
Rim size in inches	16-18
Speed Symbol	T-V
Tyre cross-section	series 60-70



M+S

'Snow tyre' means a tyre whose tread pattern, tread compound or structure is primarily designed to perform better in snow conditions than a normal tyre with regard to its ability to initiate or maintain vehicle motion.

SUV Allround tyres

ContiCrossContact™ LX Sport

For SUVs and offroad vehicles



- › Outstanding handling for on-road and general off-road use
- › Excellent braking performance on dry and wet roads
- › Optimised rolling resistance
- › Asymmetrical non-directional tread pattern

M+S	Tyre dimensions*
	Tyre width in mm 215-315
	Rim size in inches 16-22
	Speed Symbol T-Y
	Tyre cross-section series 30-70

Also available as SSR runflat tyre and with noise reducing ContiSilent™ technology. See page 23 / 25 for further details.



4x4Contact™

For SUVs and offroad vehicles



- › Excellent noise level and comfort in on-road use
- › Good protection against aquaplaning
- › Superb traction both on- and off-road
- › Asymmetrical non-directional tread pattern

M+S	Tyre dimensions*
	Tyre width in mm 195-275
	Rim size in inches 15-19
	Speed Symbol S-V
	Tyre cross-section series 45-80



M+S

'Snow tyre' means a tyre whose tread pattern, tread compound or structure is primarily designed to perform better in snow conditions than a normal tyre with regard to its ability to initiate or maintain vehicle motion.

4x4 tyres

CrossContact™ ATR

For SUVs, pickup trucks and off-road vehicles



- › Additional off-road traction and grip
- › Increased wet traction and braking on slippery roads
- › Improved overall durability
- › Substantial road noise reduction
- › Non-directional tread pattern

M+S	Tyre dimensions*
	Tyre width in mm 205-275
	Rim size in inches 15-20
	Speed Symbol R-W
	Tyre cross-section series 40-85



Winter tyres

WinterContact™ TS 860

For compact and mid-sized vehicles

- › Cool Chili™ ensures maximum braking performance in any wintry weather condition
- › Liquid Layer Drainage™ reduces the braking distance on frostcovered and icy roads
- › Snow Curve+ technology for safe cornering on snow-covered roads
- › Directional tread pattern



Tyre dimensions*

Tyre width in mm	155-225
Rim size in inches	13-17
Speed Symbol	T-V
Tyre cross-section	series 40-80



WinterContact™ TS 850 P

For mid-sized and luxury vehicles

- › Enhanced snow traction given by the S-GRIP pattern layout
- › Improved handling on snow due to PrecisionPlus
- › Reduced stopping distances via ActiveBand
- › Asymmetrical non-directional tread pattern



Tyre dimensions*

Tyre width in mm	155-315
Rim size in inches	15-22
Speed Symbol	T-W
Tyre cross-section	series 30-75

Also available as SSR runflat tyre, ContiSeal™ tyre and with noise reducing ContiSilent™ technology. See page 23 - 25 for further details.



The Alpine symbol identifies winter tyres according to UNECE regulations (valid in the EU and various other countries) and the tyre regulations of the USA and Canada. The snow performance of these winter tyres has to be proven by objective tests and meet or exceed defined limits. These tyres provide high performance with regards to safety and control on snow, on icy roads and in general at low temperatures.

M+S

'Snow tyre' means a tyre whose tread pattern, tread compound or structure is primarily designed to perform better in snow conditions than a normal tyre with regard to its ability to initiate or maintain vehicle motion.

WinterContact™ TS 860 S

Winter UHP tyre for premium sports cars

- › Excellent snow performance for outstanding driving pleasure
- › Best braking performance for maximum winter safety
- › Superb dry handling performance for highest steering precision
- › Exceptional low rolling resistance for reduced fuel consumption
- › Asymmetrical non-directional tread pattern



Tyre dimensions*

Tyre width in mm	195-315
Rim size in inches	16-22
Speed Symbol	H-Y
Tyre cross-section	series 30-60

Also available as SSR runflat tyre (in preparation).



ContiWinterContact™ TS 850

For compact and medium range vehicles

- › Improved braking performance on snow, ice and wet roads
- › Short braking distances on ice
- › More economical thanks to reduced rolling resistance and increased mileage
- › Directional tread pattern



Tyre dimensions*

Tyre width in mm	185-205
Rim size in inches	14-16
Speed Symbol	T/H
Tyre cross-section	series 55-65

Also available as ContiSeal™ tyre. See page 24 for further details



Winter tyres

ContiWinterContact™ TS 830 P

For powerful vehicles



- › Exceptional braking power on ice and snow
- › Better snow traction
- › High mileage
- › Asymmetrical non-directional tread pattern



Tyre dimensions*

Tyre width in mm	195-305
Rim size in inches	15-21
Speed Symbol	T-W
Tyre cross-section	series 30-65

Also available as SSR runflat tyre and ContiSeal™ tyre.
See page 23 / 24 for further details.



The Alpine symbol identifies winter tyres according to UNECE regulations (valid in the EU and various other countries) and the tyre regulations of the USA and Canada. The snow performance of these winter tyres has to be proven by objective tests and meet or exceed defined limits. These tyres provide high performance with regards to safety and control on snow, on icy roads and in general at low temperatures.

M+S

'Snow tyre' means a tyre whose tread pattern, tread compound or structure is primarily designed to perform better in snow conditions than a normal tyre with regard to its ability to initiate or maintain vehicle motion.

SUV Winter tyres

4x4WinterContact™

For SUVs and offroad vehicles



- › Excellent traction and braking performance
- › Excellent driving comfort and a quiet ride
- › Excellent resistance to aquaplaning
- › Asymmetrical non-directional tread pattern



Tyre dimensions*

Tyre width in mm	215-265
Rim size in inches	17-18
Speed Symbol	H
Tyre cross-section	series 55-65

Also available as SSR tyre.
See page 23 for further details.

ContiCrossContact™ Winter

For SUVs and offroad vehicles



- › Excellent traction and braking performance on snow and wet roads
- › Brilliant handling on snowy and wet roads
- › High level of safety protection against aquaplaning
- › Asymmetrical non-directional tread pattern



Tyre dimensions*

Tyre width in mm	175-295
Rim size in inches	15-22
Speed Symbol	Q-V
Tyre cross-section	series 40-80

Allseason tyre

AllSeasonContact™

Fully controlled and balanced throughout the year



- > Impressive grip on snowy and wet winter roads
- > Good braking performance on dry and wet summer roads
- > Best-in-class rolling resistance performance
- > Directional tread pattern



Tyre dimensions*

Tyre width in mm	155-255
Rim size in inches	14-20
Speed Symbol	T-Y
Tyre cross-section	series 40-70

Also available as ContiSeal™ tyre.
See page 24 for further details.

* EU label values per article no. see www.eu-tyre-label.com



The Alpine symbol identifies winter tyres according to UNECE regulations (valid in the EU and various other countries) and the tyre regulations of the USA and Canada. The snow performance of these winter tyres has to be proven by objective tests and meet or exceed defined limits. These tyres provide high performance with regards to safety and control on snow, on icy roads and in general at low temperatures.



'Snow tyre' means a tyre whose tread pattern, tread compound or structure is primarily designed to perform better in snow conditions than a normal tyre with regard to its ability to initiate or maintain vehicle motion.

The SSR tyres from Continental and Uniroyal - advanced runflat technology.



- > Reduced danger and hassle
- > Drive to safety for up to 80 km (50 miles) of 80 km/h (50 mph)
- > Compatible with standard wheel rims (H 2)
- > No need for a spare wheel and jack

The secret of SSR.

Continental's SSR tyres use reinforced sidewalls to support the vehicle in the event of a loss of air pressure.

SSR technology prevents the side of the flat tyre from being crushed between the road and wheel rim.



Standard tyres

The deflated tyre gets trapped beneath the rim and is destroyed



SSR runflat tyres

The stable sidewalls support the tyre if it loses air.

Increased safety thanks to reinforced sidewalls.

SSR tyres allow for a controlled continuation of your journey at a reduced speed of up to a distance of 80 km at a maximum speed of 80 km/h depending on the condition of the roads, the condition of the tyre and the weight of the vehicle.

Communication between tyre and driver.

As SSR tyres offer a very high standard of driving comfort, the driver will barely notice any loss of pressure in the tyre. For this reason, Continental SSR tyres may only be used on vehicles equipped with a tyre pressure monitoring system, which will display the drop in tyre pressure on the dashbord instrument panel.

Note:

SSR tyres may only be fitted on vehicles for which they are approved by the vehicle manufacturer and that are equipped with a tyre pressure monitoring system.

The tread patterns and sizes available as SSR runflat tyre can be found in the current product range of summer and winter passenger tyres.

As dealer, you need to get training and certification for the professional mounting and removal of SSR tyres under www.conti-ssr.co.uk - see also www.conti-ssr.com

(SSR training, product information and certificate).

ContiSeal™ - the self-sealing standard production tyre from Continental.

For enhanced mobility and safety, even if a foreign object penetrates the tyre tread.

ContiSeal™ tyres contain an innovative technology which seals punctures in the tread area. ContiSeal™ tyres have a sticky, viscous layer in the tread area that instantly seals punctures caused by nails and other objects up to 5 mm in diameter. The layer temporarily seals the vast majority of tyre tread punctures.

The material in the sealant layer prevents air loss even if the penetrating object becomes dislodged. As a result there is no need to stop straight away or change the tyre immediately in the event of a puncture. Despite this, the tyre should be taken as soon as possible to a tyre specialist who can examine it to determine if it needs a permanent repair.

ContiSeal™ tyres are instantly recognisable by the nail symbol on the sidewall and are compatible with all commonly available wheel rims.

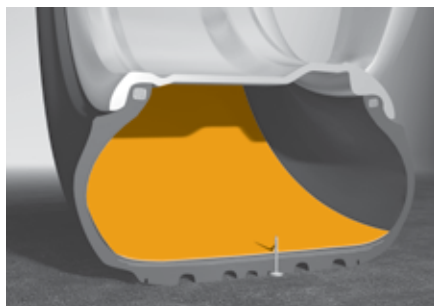

ContiSeal™ tyres - the benefits at a glance:

- › punctures in the tread area caused by penetrating objects up to 5 mm in diameter are sealed
- › holes are sealed even if the penetrating object becomes dislodged
- › same high performance under normal driving conditions as non ContiSeal™ tyres
- › no need to stop straight away or change the tyre

For detailed information about ContiSeal™ tyres - use, inspection, storing, mouting / demounting, repair, disposal - please see www.contiseal.com



ContiSilent™ - the tyre for less interior noise.



- › Reduced interior noise on all road surfaces
- › ContiSilent™ functions in all weather conditions
- › No change in any other driving characteristics
- › No negative influence on mileage and load / speed capability
- › Same mounting and storage as for standard tyres

Technical highlights.

ContiSilent™ is a tyre noise-reducing technology developed by Continental. It is designed to reduce interior noise on all road surfaces. ContiSilent™ tyres are equipped with an inner tyre absorber, a polyurethane foam, attached to the inner surface of the tread area with an adhesive. Regardless of the temperature, the structure of the foam stays intact.

ContiSilent™ helps reduce interior vehicle noise up to 9 dB(A), depending on the type of vehicle, its speed and the road surface. It is available for summer and winter tyres and is compatible with all commonly available rims. Driving performance is not affected and there is no negative influence on mileage and load / speed capability. Fitting on four positions is recommended.

ContiSilent™ principle.

ContiSilent™ tyre.

A ContiSilent™ tyre contains a polyurethane foam. It is firmly attached to an adhesive layer on the inner surface of the tyre tread area.



For further information please visit www.continental-tires.com/car/technology/contisilent

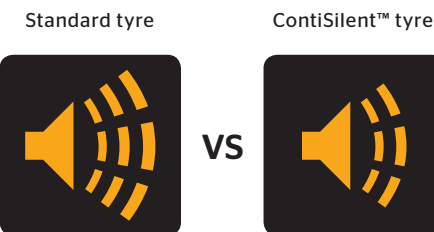

Size	Tyre		Permitted rims ¹⁾ (measuring rim bold)	Tyre dimensions Max. standard value in operation ²⁾		Radius stat. + / - 2 % (mm)	Rolling circumference ³⁾ + 1.5 % - 2.5 % (mm)
	Load Index LI	Load capacity kg		Width (mm)	Outer-Ø (mm)		
82/80 series							
175 R 13	86	530	4.50 B ⁴⁾	179			
			5.00 B⁴⁾	184	622	274	1861
			5.50 B ⁴⁾	189			
			6.00 B ⁴⁾	194			
125/80 R 13	65	290	3.00 B ⁴⁾	126			
			3.50 B⁴⁾	131	538	243	1617
			4.00 B ⁴⁾	136			
135/80 R 13	70	335	3.50 B⁴⁾	138	554	249	1665
			4.00 B ⁴⁾	143			
			4.50 B ⁴⁾	148			
145/80 R 13	75	387	3.50 B ⁴⁾	146			
			4.00 B⁴⁾	151	572	255	1714
			4.50 B ⁴⁾	156			
			5 J	161			
155/80 R 13	79	437	4.00 B ⁴⁾	158			
155/80 R 13 XL	83	487	4.50 B⁴⁾	163	588	262	1763
			5.00 B ⁴⁾	168			
165/80 R 13	83	487	4.00 B ⁴⁾	167			
165/80 R 13 XL	87	545	4.50 B⁴⁾	172	604	268	1812
			5.00 B ⁴⁾	177			
			5.50 B ⁴⁾	182			
145/80 R 14	76	400	3.50 B ⁴⁾	146			
			4.00 B⁴⁾	151	598	268	1793
			4.50 B ⁴⁾	156			
			5.00 B ⁴⁾	161			
165/80 R 14	85	515	4 J	167			
			4 ½ J	172	630	281	1891
			5 J	177			
			5 ½ J	182			
175/80 R 14	88	560	4 ½ J	179			
			5 J	184	648	287	1940
			5 ½ J	189			
			6 J	194			
185/80 R 14	91	615	4 ½ J	186			
			5 J	191	664	293	1989
			5 ½ J	196			
			6 J	201			
165/80 R 15	87	545	4 J	167			
			4 ½ J	172	655	293	1967
			5 J	177			
			5 ½ J	182			
195/80 R 15	96	710	5 J	199			
			5 ½ J	204	705	312	2114
			6 J	209			
			6 ½ J	214			

Size	Tyre		Permitted rims ¹⁾ (measuring rim bold)	Tyre dimensions Max. standard value in operation ²⁾		Radius stat. + / - 2 % (mm)	Rolling circumference ³⁾ + 1.5 % - 2.5 % (mm)
	Load Index LI	Load capacity kg		Width (mm)	Outer-Ø (mm)		
80 series							
215/80 R 15	102	850	5 ½ J	220			
			6 J	225	739	325	2211
			6 ½ J	230			
			7 J	235			
205/80 R 16 XL / Rf.	104	900	5 J	206			
			5 ½ J	211	748	331	2239
			6 J	216			
			6 ½ J	221			
			7 J	226			
75 series							
205/75 R 15	97	730	5 J	206			
			5 ½ J	211	701	311	2101
			6 J	216			
			6 ½ J	221			
			7 J	226			
215/75 R 15	100	800	5 ½ J	220			
			6 J	225	715	316	2144
			6 ½ J	230			
			7 J	235			
225/75 R 15	102	850	6 J	232	733	322	2193
			6 ½ J	237			
			7 J	242			
			7 ½ J	247			
P 235/75 R 15	105	925	6 J	239			
235/75 R 15 XL	109	1030	6 ½ J	244	747	328	2236
			7 J	249			
			7 ½ J	254			
			8 J	259			
265/75 R 15	112	1120	7 J	273			
			7 ½ J	278	795	346	2376
			8 J	283			
			8 ½ J	288			
			9 J	293			
195/75 R 16 Rf.	100	800	5 J	199			
			5 ½ J	204	710	317	2129
			6 J	209			
			6 ½ J	214			
215/75 R 16 XL	107	975	5 ½ J	220			
			6 J	225	740	329	2220
			6 ½ J	230			
			7 J	235			
225/75 R 16	104	900	6 J	232	758	335	2269
225/75 R 16 XL	108	1000	6 ½ J	237			
			7 J	242			
			7 ½ J	247			

Size	Tyre		Permitted rims ¹⁾ (measuring rim bold)	Tyre dimensions Max. standard value in operation ²⁾		Radius stat. + / - 2 % (mm)	Rolling circumference ³⁾ + 1.5 % - 2.5 % (mm)
	Load Index	Load capacity		Width (mm)	Outer-Ø (mm)		
	LI	kg					
75 series							
235/75 R 16	108	1000	6 J	239			
235/75 R 16 XL	112	1120	6 ½ J	244	772	340	2312
			7 J	249			
			7 ½ J	254			
			8 J	259			
245/75 R 16	111	1090	6 ½ J	253			
			7 J	258	788	347	2361
			7 ½ J	263			
			8 J	268			
265/75 R 16	116	1250	7 J	273			
			7 ½ J	278	820	358	2452
			8 J	283			
			8 ½ J	288			
			9 J	293			
235/75 R 17	109	1030	6 J	239			
			6 ½ J	244	798	353	2391
			7 J	249			
			7 ½ J	254			
			8 J	259			
70 series							
135/70 R 13	68	315	3.50 B ⁴⁾	139			
			4.00 B⁴⁾	144	528	239	1586
			4.50 B ⁴⁾	149			
145/70 R 13	71	345	3.50 B ⁴⁾	146			
			4.00 B ⁴⁾	151			
			4.50 B⁴⁾	156	542	245	1629
			5.00 B ⁴⁾	161			
155/70 R 13	75	387	4.00 B ⁴⁾	158			
			4.50 B⁴⁾	163	556	250	1671
			5.00 B ⁴⁾	168			
165/70 R 13	79	437	4.00 B ⁴⁾	167			
165/70 R 13 XL / Rf.	83	487	4.50 B ⁴⁾	172			
			5.00 B⁴⁾	177	572	255	1714
			5.50 B ⁴⁾	182			
175/70 R 13	82	475	4.50 B ⁴⁾	179			
175/70 R 13 XL	86	530	5.00 B⁴⁾	184	586	261	1757
			5.50 B ⁴⁾	189			
			6.00 B ⁴⁾	194			
185/70 R 13	86	530	4.50 B ⁴⁾	187			
			5.00 B ⁴⁾	192			
			5.50 B⁴⁾	197	600	266	1800
			6.00 B ⁴⁾	202			
155/70 R 14	77	412	4.00 B ⁴⁾	158			
			4.50 B⁴⁾	163	582	263	1751
			5.00 B ⁴⁾	168			

Size	Tyre		Permitted rims ¹⁾ (measuring rim bold)	Tyre dimensions Max. standard value in operation ²⁾		Radius stat. + / - 2 % (mm)	Rolling circumference ³⁾ + 1.5 % - 2.5 % (mm)
	Load Index	Load capacity		Width (mm)	Outer-Ø (mm)		
	LI	kg					
70 series							
165/70 R 14	81	462	4 J	167			
165/70 R 14 XL / Rf.	85	515	4.50 B ⁴⁾	172			
			5.00 B⁴⁾	177	598	268	1793
			5.50 B ⁴⁾	182			
175/70 R 14	84	500	4 ½ J	179			
175/70 R 14 XL	88	560	5.00 B⁴⁾	184	612	274	1836
			5.50 B ⁴⁾	189			
			6 J	194			
185/70 R 14	88	560	4 ½ J	187			
185/70 R 14 XL	92	630	5 J	192			
			5 ½ J	197	626	279	1879
			6 J	202			
195/70 R 14	91	615	5 J	199			
			5 ½ J	204	640	285	1922
			6 J	209			
			6 ½ J	214			
205/70 R 14	95	690	5 J	207			
205/70 R 14 XL	98	750	5 ½ J	212			
			6 J	217	656	290	1964
			6 ½ J	222			
			7 J	227			
135/70 R 15	70	335	3 ½ J	139			
			4 J	144	579	265	1742
			4 ½ J	149			
155/70 R 15	78	425	4 J	158			
			4 ½ J	163	607	276	1827
			5 J	168			
195/70 R 15 Rf.	97	730	5 J	199			
			5 ½ J	204			
			6 J	209	665	297	1998
			6 ½ J	214			
205/70 R 15	96	710	5 J	207			
205/70 R 15 XL	100	800	5 ½ J	212			
			6 J	217	681	303	2040
			6 ½ J	222			
			7 J	227			
215/70 R 15	98	750	5 ½ J	220			
			6 J	225			
			6 ½ J	230	695	308	2083
			7 J	235			
225/70 R 15	100	800	6 J	232			
P 225/70 R 15			6 ½ J	237	709	314	2126
			7 J	242			
			7 ½ J	247			

Size	Tyre		Permitted rims ¹⁾ (measuring rim bold)	Tyre dimensions Max. standard value in operation ²⁾		Radius stat. + / - 2 % (mm)	Rolling circumference ³⁾ + 1.5 % - 2.5 % (mm)
	Load Index	Load capacity		Width (mm)	Outer-Ø (mm)		
	LI	kg					
70 series							
235/70 R 15	103	875	6 J	240			
P 235/70 R 15			6 ½ J	245			
			7 J	250	725	319	2169
			7 ½ J	255			
			8 J	260			
255/70 R 15	108	1000	6 ½ J	260			
			7 J	265			
			7 ½ J	270	753	330	2254
			8 J	275			
			8 ½ J	280			
265/70 R 15	112	1120	7 J	273			
			7 ½ J	278			
			8 J	283	767	336	2297
			8 ½ J	288			
			9 J	293			
195/70 R 16	94	670	5 J	199			
			5 ½ J	204			
			6 J	209	690	310	2074
			6 ½ J	214			
205/70 R 16	97	730	5 J	207			
			5 ½ J	212			
			6 J	217	706	315	2117
			6 ½ J	222			
			7 J	227			
215/70 R 16	100	800	5 ½ J	220			
215/70 R 16 XL	104	900	6 J	225			
			6 ½ J	230	720	321	2159
			7 J	235			
225/70 R 16	102	850	6 J	232			
		875	6 ½ J	237	734	326	2202
225/70 R 16 XL	107	975	7 J	242			
			7 ½ J	247			
P 235/70 R 16	104	900	6 J	240			
235/70 R 16	106	950	6 ½ J	245			
			7 J	250	750	332	2245
			7 ½ J	255			
			8 J	260			
245/70 R 16	107	975	6 ½ J	253			
245/70 R 16 XL	111	1090	7 J	258	764	337	2288
			7 ½ J	263			
			8 J	268			
255/70 R 16	111	1090	6 ½ J	260			
255/70 R 16 XL	115	1215	7 J	265			
			7 ½ J	270	778	343	2330
			8 J	275			
			8 ½ J	280			

Size	Tyre		Permitted rims ¹⁾ (measuring rim bold)	Tyre dimensions Max. standard value in operation ²⁾		Radius stat. + / - 2 % (mm)	Rolling circumference ³⁾ + 1.5 % - 2.5 % (mm)	
	Load Index	Load capacity		Width (mm)	Outer-Ø (mm)			
	LI	kg						
70 series								
265/70 R 16	112	1120	7 J	273				
			7 ½ J	278				
			8 J	283	792	348	2373	
			8 ½ J	288				
			9 J	293				
275/70 R 16	114	1180	7 J	280				
			7 ½ J	285				
			8 J	290	808	354	2416	
			8 ½ J	295				
			9 J	300				
225/70 R 17 XL	108	1000	6 J	232				
			6 ½ J	237	760	339	2281	
			7 J	242				
			7 ½ J	247				
235/70 R 17 XL	109	1030	6 J	240				
			6 ½ J	245				
			7 J	250	776	345	2324	
			7 ½ J	255				
	8 J	260						
P 245/70 R 17	108	1000	6 ½ J	253				
245/70 R 17	110	1060	7 J	258	790	350	2367	
245/70 R 17 XL			114	1180	7 ½ J	263		
					8 J	268		
P 255/70 R 17	110	1060	6 ½ J	260				
255/70 R 17	112	1120	7 J	265				
			7 ½ J	270	804	356	2410	
			8 J	275				
			8 ½ J	280				
P 265/70 R 17	113	1150	7 J	273				
265/70 R 17	115	1215	7 ½ J	278				
			8 J	283	818	361	2452	
			8 ½ J	288				
			9 J	293				
235/70 R 18 XL	110	1060	6 J	240				
			6 ½ J	245				
			7 J	250	801	357	2400	
			7 ½ J	255				
			8 J	260				

Size	Tyre		Permitted rims ¹⁾ (measuring rim bold)	Tyre dimensions Max. standard value in operation ²⁾		Radius stat. + / - 2 % (mm)	Rolling circumference ³⁾ + 1.5 % - 2.5 % (mm)
	Load Index LI	Load capacity kg		Width (mm)	Outer-Ø (mm)		
70 series							
265/70 R 18	116	1250	7 J	273			
			7 ½ J	278			
			8 J	283	843	374	2528
			8 ½ J	288			
			9 J	293			
155/70 R 19	84	500	4 J	158			
155/70 R 19 XL	88	560	4 ½ J	163	709	327	2138
			5 J	168			
65 series							
155/65 R 13	73	365	4.50 B⁴⁾	163	540	244	1623
			5.00 B ⁴⁾	168			
			5.50 B ⁴⁾	173			
165/65 R 13	77	412	4.50 B ⁴⁾	172			
			5.00 B⁴⁾	177	552	248	1659
			5.50 B ⁴⁾	182			
			6.00 B ⁴⁾	187			
175/65 R 13	80	450	5.00 B⁴⁾	184	568	254	1702
			5.50 B ⁴⁾	189			
			6.00 B ⁴⁾	194			
155/65 R 14	75	387	4.50 B⁴⁾	163	566	257	1702
155/65 R 14 XL	79	437	5.00 B ⁴⁾	168			
			5.50 B ⁴⁾	173			
165/65 R 14	79	437	4.50 B ⁴⁾	172			
165/65 R 14 XL	83	487	5.00 B⁴⁾	177	578	261	1739
			5.50 B ⁴⁾	182			
			6 J	187			
175/65 R 14	82	475	5.00 B⁴⁾	184	594	267	1781
175/65 R 14 XL / Rf.	86	530	5.50 B ⁴⁾	189			
			6 J	194			
185/65 R 14	86	530	5 J	192			
185/65 R 14 XL	90	600	5 ½ J	197	606	272	1818
			6 J	202			
			6 ½ J	207			
195/65 R 14	89	580	5 ½ J	204			
			6 J	209	620	277	1861
			6 ½ J	214			
			7 J	219			
145/65 R 15	72	355	4 J	151			
			4 ½ J	156	577	264	1735
			5 J	161			
155/65 R 15	77	412	4 ½ J	163	591	269	1778
			5 J	168			
			5 ½ J	173			

Size	Tyre		Permitted rims ¹⁾ (measuring rim bold)	Tyre dimensions Max. standard value in operation ²⁾		Radius stat. + / - 2 % (mm)	Rolling circumference ³⁾ + 1.5 % - 2.5 % (mm)
	Load Index LI	Load capacity kg		Width (mm)	Outer-Ø (mm)		
65 series							
165/65 R 15	81	462	4 ½ J	172			
			5 J	177	603	274	1815
			5 ½ J	182			
			6 J	187			
175/65 R 15	84	500	5 J	184	619	279	1857
175/65 R 15 XL	88	560	5 ½ J	189			
			6 J	194			
185/65 R 15	88	560	5 J	192			
185/65 R 15 XL / Rf.	92	630	5 ½ J	197	631	284	1894
			6 J	202			
			6 ½ J	207			
195/65 R 15	91	615	5 ½ J	204			
195/65 R 15 XL / Rf.	95	690	6 J	209	645	290	1937
			6 ½ J	214			
			7 J	219			
205/65 R 15	94	670	5 ½ J	212			
205/65 R 15 XL / Rf.	99	775	6 J	217	657	294	1973
			6 ½ J	222			
			7 J	227			
			7 ½ J	232			
215/65 R 15	96	710	6 J	225			
215/65 R 15 Rf.	100	800	6 ½ J	230	673	300	2016
			7 J	235			
			7 ½ J	240			
195/65 R 16	92	630	5 ½ J	204			
			6 J	209	670	302	2013
			6 ½ J	214			
			7 J	219			
205/65 R 16	95	690	5 ½ J	212			
			6 J	217	682	307	2050
			6 ½ J	222			
			7 J	227			
			7 ½ J	232			
215/65 R 16	98	750	6 J	225			
215/65 R 16 XL	102	850	6 ½ J	230	698	312	2092
			7 J	235			
			7 ½ J	240			
235/65 R 16	103	875	6 ½ J	245			
			7 J	250	724	322	2172
			7 ½ J	255			
			8 J	260			
			8 ½ J	265			

Size	Tyre		Permitted rims ¹⁾ (measuring rim bold)	Tyre dimensions Max. standard value in operation ²⁾		Radius stat. + / - 2 % (mm)	Rolling circumference ³⁾ + 1.5 % - 2.5 % (mm)
	Load Index	Load capacity		Width (mm)	Outer-Ø (mm)		
	LI	kg					
65 series							
255/65 R 16	109	1030	7 J	265			
			7 ½ J	270	752	332	2251
			8 J	275			
			8 ½ J	280			
205/65 R 17	96	710	9 J	285			
			5 ½ J	212			
			6 J	217	708	320	2129
			6 ½ J	222			
215/65 R 17	99	775	7 J	227			
			7 ½ J	232			
			6 J	225			
215/65 R 17 XL	103	875	6 ½ J	230	724	325	2172
			7 J	235			
			7 ½ J	240			
225/65 R 17	102	850	8 J	242			
			6 ½ J	237	736	330	2208
225/65 R 17 XL	106	950	7 J	247			
			7 ½ J	252			
			8 J	252			
235/65 R 17	103	875	6 ½ J	245			
			7 J	250	750	335	2251
235/65 R 17 XL	104	900	7 ½ J	255			
			8 J	260			
			8 ½ J	265			
245/65 R 17	107	975	8 ½ J	265			
			7 J	258	762	340	2288
245/65 R 17 XL	111	1090	7 ½ J	263			
			8 J	268			
			8 ½ J	273			
255/65 R 17	110	1060	7 J	265			
			7 ½ J	270	778	345	2330
255/65 R 17 XL	114	1180	8 J	275			
			8 ½ J	280			
			9 J	285			
265/65 R 17	112	1120	9 J	285			
			7 ½ J	278			
			8 J	283	790	350	2367
			8 ½ J	288			
265/65 R 17 XL	116	1250	9 ½ J	293			
			9 J	298			
			7 ½ J	285			
275/65 R 17	115	1215	8 J	285			
			8 J	290	804	356	2410
			8 ½ J	295			
			9 J	300			
			9 ½ J	305			

Size	Tyre		Permitted rims ¹⁾ (measuring rim bold)	Tyre dimensions Max. standard value in operation ²⁾		Radius stat. + / - 2 % (mm)	Rolling circumference ³⁾ + 1.5 % - 2.5 % (mm)
	Load Index	Load capacity		Width (mm)	Outer-Ø (mm)		
	LI	kg					
65 series							
285/65 R 17	116	1250	8 J	299			
			8 ½ J	304	816	360	2446
			9 J	309			
			9 ½ J	314			
			10 J	319			
235/65 R 18	106	950	6 ½ J	245			
235/65 R 18 XL	110	1060	7 J	250	775	348	2327
			7 ½ J	255			
			8 J	260			
			8 ½ J	265			
255/65 R 18	111	1090	7 J	265			
			7 ½ J	270	803	358	2406
			8 J	275			
			8 ½ J	280			
			9 J	285			
265/65 R 18	114	1180	7 ½ J	278			
			8 J	283	815	363	2443
			8 ½ J	288			
			9 J	293			
275/65 R 18	116	1250	9 ½ J	298			
			7 ½ J	285			
			8 J	290	829	368	2486
			8 ½ J	295			
235/65 R 19 XL	109	1030	9 J	300			
			9 ½ J	305			
			6 ½ J	245			
235/65 R 19 XL	109	1030	7 J	250	801	361	2406
			7 ½ J	255			
			8 J	260			
			8 ½ J	265			
255/65 R 19 XL	114	1180	7 J	265			
			7 ½ J	270	829	371	2486
			8 J	275			
			8 ½ J	280			
			9 J	285			
60 series							
175/60 R 13	77	412	5 J	184	548	247	1647
			5 ½ J	189			
			6 J	194			
185/60 R 13	80	450	5.00 B ⁴⁾	192			
			5.50 B⁴⁾	197	560	252	1684
			6.00 B ⁴⁾	202			
			6 ½ J	207			

Size	Tyre		Permitted rims ¹⁾ (measuring rim bold)	Tyre dimensions Max. standard value in operation ²⁾		Radius stat. + / - 2 % (mm)	Rolling circumference ³⁾ + 1.5 % - 2.5 % (mm)
	Load Index LI	Load capacity kg		Width (mm)	Outer-Ø (mm)		
60 series							
165/60 R 14	75	387	4 ½ J	172			
165/60 R 14 XL	79	437	5 J³⁾	177	562	255	1690
			5 ½ J	182			
			6 J	187			
175/60 R 14	79	437	5 J³⁾	184	574	260	1726
			5 ½ J	189			
			6 J	194			
185/60 R 14	82	475	5 J	192			
185/60 R 14 XL	86	530	5 ½ J	197	586	265	1763
			6 J	202			
			6 ½ J	207			
195/60 R 14	86	530	5 ½ J	204			
			6 J	209	600	269	1800
			6 ½ J	214			
			7 J	219			
155/60 R 15	74	375	4 ½ J	163	575	263	1729
			5 J	168			
			5 ½ J	174			
165/60 R 15	77	412	4.50 B ⁴⁾	172			
165/60 R 15 XL	81	462	5.00 B⁴⁾	177	587	268	1766
			5.50 B ⁴⁾	182			
			6.00 B ⁴⁾	187			
175/60 R 15	81	462	5 J	184	599	272	1803
			5 ½ J	189			
			6 J	194			
185/60 R 15	84	500	5 J	192			
185/60 R 15 XL	88	560	5 ½ J	197	611	277	1839
			6 J	202			
			6 ½ J	207			
195/60 R 15	88	560	5 ½ J	204			
195/60 R 15 XL	92	630	6 J	209	625	282	1876
			6 ½ J	214			
			7 J	219			
205/60 R 15	91	615	5 ½ J	212			
205/60 R 15 XL / Rf.	95	690	6 J	217	637	286	1912
			6 ½ J	222			
			7 J	227			
			7 ½ J	232			
215/60 R 15	94	670	6 J	225			
	95	690	6 ½ J	230	649	291	1949
215/60 R 15 XL	98	750	7 J	235			
			7 ½ J	240			

Size	Tyre		Permitted rims ¹⁾ (measuring rim bold)	Tyre dimensions Max. standard value in operation ²⁾		Radius stat. + / - 2 % (mm)	Rolling circumference ³⁾ + 1.5 % - 2.5 % (mm)
	Load Index LI	Load capacity kg		Width (mm)	Outer-Ø (mm)		
60 series							
225/60 R 15	96	710	6 J	232			
			6 ½ J	237	661	296	1986
			7 J	242			
			7 ½ J	247			
			8 J	252			
235/60 R 15	98	750	6 ½ J	245			
			7 J	250	675	300	2022
			7 ½ J	255			
			8 J	260			
			8 ½ J	265			
255/60 R 15	102	850	7 J	265			
			7 ½ J	270	699	310	2095
			8 J	275			
			8 ½ J	280			
			9 J	285			
275/60 R 15	107	975	7 ½ J	285			
			8 J	290	725	319	2169
			8 ½ J	295			
			9 J	300			
			9 ½ J	305			
185/60 R 16	86	530	5 J	192			
			5 ½ J	197	636	290	1915
			6 J	202			
			6 ½ J	207			
195/60 R 16	89	580	5 ½ J	204			
195/60 R 16 XL	93	650	6 J	209	650	294	1952
			6 ½ J	215			
			7 J	220			
205/60 R 16	92	630	5 ½ J	212			
205/60 R 16 XL	96	710	6 J	217	662	299	1989
			6 ½ J	222			
			7 J	227			
			7 ½ J	232			
215/60 R 16	95	690	6 J	225			
215/60 R 16 XL / Rf.	99	775	6 ½ J	230	674	304	2025
			7 J	235			
			7 ½ J	240			
225/60 R 16	98	750	6 J	232			
225/60 R 16 XL / Rf.	102	850	6 ½ J	237	686	308	2062
			7 J	242			
			7 ½ J	247			
			8 J	252			

Size	Tyre		Permitted rims ¹⁾ (measuring rim bold)	Tyre dimensions Max. standard value in operation ²⁾		Radius stat. + / - 2 % (mm)	Rolling circumference ³⁾ + 1.5 % - 2.5 % (mm)
	Load Index LI	Load capacity kg		Width (mm)	Outer-Ø (mm)		
60 series							
235/60 R 16	100	800	6 ½ J	245			
235/60 R 16 XL/Rf.	104	900	7 J	250	700	313	2098
			7 ½ J	255			
			8 J	260			
			8 ½ J	265			
205/60 R 17	93	650	5 ½ J	212			
205/60 R 17 XL	97	730	6 J	217	688	312	2068
			6 ½ J	222			
			7 J	227			
			7 ½ J	232			
215/60 R 17	96	710	6 J	225			
215/60 R 17 XL	100	800	6 ½ J	230	700	317	2105
			7 J	235			
			7 ½ J	240			
225/60 R 17	99	775	6 J	232			
225/60 R 17 XL	103	875	6 ½ J	237	712	321	2141
			7 J	242			
			7 ½ J	247			
			8 J	252			
235/60 R 17	102	850	6 ½ J	245			
235/60 R 17 XL	106	950	7 J	250	726	326	2178
			7 ½ J	255			
			8 J	260			
			8 ½ J	265			
255/60 R 17	106	950	7 J	265			
			7 ½ J	270	750	335	2251
			8 J	275			
			8 ½ J	280			
			9 J	285			
275/60 R 17	110	1060	7 ½ J	285			
			8 J	290	776	345	2324
			8 ½ J	295			
			9 J	300			
			9 ½ J	305			
195/60 R 18 XL	96	710	5 ½ J	204			
			6 J	209	701	320	2108
			6 ½ J	214			
			7 J	219			
215/60 R 18	98	750	6 J	225			
215/60 R 18 XL	102	850	6 ½ J	230	725	329	2181
			7 J	235			
			7 ½ J	240			

Size	Tyre		Permitted rims ¹⁾ (measuring rim bold)	Tyre dimensions Max. standard value in operation ²⁾		Radius stat. + / - 2 % (mm)	Rolling circumference ³⁾ + 1.5 % - 2.5 % (mm)
	Load Index LI	Load capacity kg		Width (mm)	Outer-Ø (mm)		
60 series							
P 225/60 R 18	99	775	6 J	232			
225/60 R 18	100	800	6 ½ J	237	737	334	2217
225/60 R 18 XL	104	900	7 J	242			
			7 ½ J	247			
			8 J	252			
235/60 R 18	103	875	6 ½ J	245			
235/60 R 18 XL	107	975	7 J	250	751	338	2254
			7 ½ J	255			
			8 J	260			
			8 ½ J	265			
P 245/60 R 18	104	900	7 J	258	763	343	2291
245/60 R 18	105	925	7 ½ J	263			
			8 J	268			
			8 ½ J	273			
255/60 R 18	108	1000	7 J	265			
255/60 R 18 XL	112	1120	7 ½ J	270	775	348	2327
			8 J	275			
			8 ½ J	281			
			9 J	286			
265/60 R 18	110	1060	7 ½ J	278			
265/60 R 18 XL	114	1180	8 J	283	787	353	2364
			8 ½ J	288			
			9 J	293			
			9 ½ J	298			
275/60 R 18	113	1150	7 ½ J	285			
			8 J	290	801	357	2400
			8 ½ J	295			
			9 J	300			
			9 ½ J	305			
285/60 R 18	116	1250	8 J	299			
			8 ½ J	304	813	362	2437
			9 J	309			
			9 ½ J	314			
			10 J	319			
175/60 R 19	86	530	5 J	184	701	323	2114
			5 ½ J	189			
			6 J	194			
255/60 R 19	109	1030	7 J	265			
255/60 R 19 XL	113	1150	7 ½ J	270	801	361	2406
			8 J	275			
			8 ½ J	280			
			9 J	285			
155/60 R 20	80	450	4 ½ J	163	702	327	2117
			5 J	168			
			5 ½ J	173			

Size	Tyre		Permitted rims ¹⁾ (measuring rim bold)	Tyre dimensions Max. standard value in operation ²⁾		Radius stat. + / - 2 % (mm)	Rolling circumference ³⁾ + 1.5 % - 2.5 % (mm)	
	Load Index	Load capacity		Width (mm)	Outer-Ø (mm)			
	LI	kg						
60 series								
235/60 R 20 XL	108	1000	6 ½ J	245				
			7 J	250	802	364	2410	
			7 ½ J	255				
			8 J	260				
			8 ½ J	265				
245/60 R 20	107	975	7 J	258	814	369	2446	
			7 ½ J	263				
			8 J	268				
255/60 R 20 XL	113	1150	7 J	265				
			7 ½ J	270	826	373	2483	
			8 J	275				
			8 ½ J	280				
275/60 R 20	115	1215	7 ½ J	285				
			8 J	290	852	383	2556	
			8 ½ J	295				
			9 J	300				
275/60 R 20 XL	119	1360	9 ½ J	305				
			5 J	184	***	***	****	
			5 ½ J	189				
175/60 R 22 XL+	97	730	6 J	194				
			55 series					
			5.50 B ⁴⁾	204				
195/55 R 13	80	450	6.00 B⁴⁾	209	552	248	1659	
			6 ½ J	214				
			7 J	219				
185/55 R 14	80	450	5 J	192				
			5 ½ J	197				
			6 J	202	568	258	1708	
			6 ½ J	207				
175/55 R 15	77	412	5 J	184				
			5 ½ J	189	581	265	1748	
			6 J	194				
185/55 R 15	82	475	5 J	192				
			5 ½ J	197				
185/55 R 15 XL/Rf	86	530	6 J	202	593	270	1784	
			6 ½ J	207				
			5 ½ J	204				
195/55 R 15	85	515	5 ½ J	204				
195/55 R 15 XL/Rf.	89	580	6 J	209	603	274	1815	
			6 ½ J	214				
			7 J	219				

Size	Tyre		Permitted rims ¹⁾ (measuring rim bold)	Tyre dimensions Max. standard value in operation ²⁾		Radius stat. + / - 2 % (mm)	Rolling circumference ³⁾ + 1.5 % - 2.5 % (mm)
	Load Index	Load capacity		Width (mm)	Outer-Ø (mm)		
	LI	kg					
55 series							
205/55 R 15	88	560	5 ½ J	213			
			6 J	218			
			6 ½ J	223	617	279	1851
			7 J	228			
			7 ½ J	233			
225/55 R 15	92	630	6 J	232			
			6 ½ J	237			
			7 J	242	639	287	1918
			7 ½ J	247			
185/55 R 16	83	487	8 J	252			
			5 J	192			
			5 ½ J	197			
185/55 R 16 XL	87	545	6 J	202	618	283	1861
			6 ½ J	207			
			5 ½ J	204			
195/55 R 16	87	545	5 ½ J	204			
195/55 R 16 XL	91	615	6 J	209	628	286	1891
			6 ½ J	214			
			7 J	219			
205/55 R 16	91	615	5 ½ J	213			
205/55 R 16 XL	94	670	6 J	218			
			6 ½ J	223	642	291	1928
			7 J	228			
			7 ½ J	233			
215/55 R 16	93	650	6 J	225			
215/55 R 16 XL	97	730	6 ½ J	230			
			7 J	235	652	295	1958
			7 ½ J	240			
225/55 R 16	95	690	6 J	232			
225/55 R 16 XL	99	775	6 ½ J	237			
			7 J	242	664	300	1995
			7 ½ J	247			
			8 J	252			
255/55 R 16	103	875	7 J	266			
			7 ½ J	271			
			8 J	276	698	312	2092
			8 ½ J	281			
195/55 R 17	88	560	9 J	286			
			5 ½ J	204			
			6 J	209	654	299	1970
195/55 R 17	88	560	6 ½ J	214			
			7 J	219			

Size	Tyre		Permitted rims ¹⁾ (measuring rim bold)	Tyre dimensions Max. standard value in operation ²⁾		Radius stat. + / - 2 % (mm)	Rolling circumference ³⁾ + 1.5 % - 2.5 % (mm)
	Load Index	Load capacity		Width (mm)	Outer-Ø (mm)		
	LI	kg					
55 series							
205/55 R 17	91	615	5 ½ J	213			
205/55 R 17 XL	95	690	6 J	218			
			6 ½ J	223	668	304	2007
			7 J	228			
			7 ½ J	233			
215/55 R 17	94	670	6 J	225			
215/55 R 17 XL	98	750	6 ½ J	230			
			7 J	235	678	308	2037
			7 ½ J	240			
225/55 R 17	97	730	6 J	232			
225/55 R 17 XL/Rf.	101	825	6 ½ J	237			
			7 J	242	690	313	2074
			7 ½ J	247			
			8 J	252			
235/55 R 17	99	775	6 ½ J	245			
235/55 R 17 XL/Rf.	103	875	7 J	250			
			7 ½ J	255	700	317	2105
			8 J	260			
			8 ½ J	265			
245/55 R 17	102	850	7 J	258			
245/55 R 17 XL	106	950	7 ½ J	263	712	321	2141
			8 J	268			
			8 ½ J	273			
255/55 R 17	104	900	7 J	266			
			7 ½ J	271			
			8 J	276	724	325	2172
			8 ½ J	281			
			9 J	286			
275/55 R 17	109	1030	7 ½ J	285			
			8 J	290			
			8 ½ J	295	746	334	2239
			9 J	300			
			9 ½ J	305			
205/55 R 18 XL	96	710	5 ½ J	213			
			6 J	218			
			6 ½ J	223	693	317	2083
			7 J	228			
			7 ½ J	233			
215/55 R 18	95	690	6 J	225			
215/55 R 18 XL	99	775	6 ½ J	230			
			7 J	235	703	321	2114
			7 ½ J	240			

Size	Tyre		Permitted rims ¹⁾ (measuring rim bold)	Tyre dimensions Max. standard value in operation ²⁾		Radius stat. + / - 2 % (mm)	Rolling circumference ³⁾ + 1.5 % - 2.5 % (mm)
	Load Index	Load capacity		Width (mm)	Outer-Ø (mm)		
	LI	kg					
55 series							
225/55 R 18	98	750	6 J	232			
225/55 R 18 XL	102	850	6 ½ J	237			
			7 J	242	715	325	2150
			7 ½ J	247			
			8 J	252			
235/55 R 18	100	800	6 ½ J	245			
235/55 R 18 XL	104	900	7 J	250			
			7 ½ J	255	725	329	2181
			8 J	260			
			8 ½ J	266			
245/55 R 18 XL	107	975	7 J	258			
			7 ½ J	263	737	334	2217
			8 J	268			
			8 ½ J	273			
255/55 R 18	105	925	7 J	266			
255/55 R 18 XL	109	1030	7 ½ J	271			
			8 J	276	749	338	2248
			8 ½ J	281			
			9 J	286			
205/55 R 19 XL	97	730	5 ½ J	213			
			6 J	218			
			6 ½ J	223	719	330	2162
			7 J	228			
			7 ½ J	233			
225/55 R 19	99	775	6 J	232			
225/55 R 19 XL	103	875	6 ½ J	237			
			7 J	242	741	338	2230
			7 ½ J	247			
			8 J	252			
235/55 R 19	101	825	6 ½ J	245			
235/55 R 19 XL	105	925	7 J	250			
			7 ½ J	255	751	342	2260
			8 J	260			
			8 ½ J	266			
245/55 R 19	103	875	7 J	258			
			7 ½ J	263	763	347	2297
			8 J	268			
			8 ½ J	273			
255/55 R 19	107	975	7 J	265			
255/55 R 19 XL	111	1090	7 ½ J	270			
			8 J	276	775	351	2327
			8 ½ J	281			
			9 J	286			

Size	Tyre		Permitted rims ¹⁾ (measuring rim bold)	Tyre dimensions Max. standard value in operation ²⁾		Radius stat. + / - 2 % (mm)	Rolling circumference ³⁾ + 1.5 % - 2.5 % (mm)
	Load Index LI	Load capacity kg		Width (mm)	Outer-Ø (mm)		
55 series							
265/55 R 19	109	1030	7 ½ J	278			
265/55 R 19 XL	113	1150	8 J	283			
			8 ½ J	288	787	355	2364
			9 J	293			
			9 ½ J	298			
275/55 R 19	111	1090	7 ½ J	285			
			8 J	290			
			8 ½ J	295	797	359	2394
			9 J	300			
9 ½ J	305						
175/55 R 20	85	515	5 J	184			
			5 ½ J	189	708	329	2135
			6 J	194			
195/55 R 20 XL	95	690	5 ½ J	204			
			6 J	209	730	337	2202
			6 ½ J	214			
7 J	219						
235/55 R 20	102	850	6 ½ J	245			
235/55 R 20 XL	105	925	7 J	250			
			7 ½ J	255	776	355	2336
			8 J	260			
			8 ½ J	265			
255/55 R 20	107	975	7 J	265			
255/55 R 20 XL	110	1060	7 ½ J	270			
			8 J	276	800	363	2403
			8 ½ J	281			
			9 J	286			
P 275/55 R 20	111	1090	7 ½ J	285			
275/55 R 20 XL	117	1285	8 J	290			
			8 ½ J	295	822	372	2471
			9 J	300			
			9 ½ J	305			
50 series							
175/50 R 13	72	355	5.00 B ⁴⁾	184			
			5.50 B⁴⁾	189	514	234	1543
			6.00 B ⁴⁾	194			
185/50 R 14	77	412	5 J	192			
			5 ½ J	197			
			6 J	202	550	251	1653
			6 ½ J	207			
165/50 R 15	72	355	4 ½ J	172			
			5 J	177	553	255	1668
			5 ½ J	182			

Size	Tyre		Permitted rims ¹⁾ (measuring rim bold)	Tyre dimensions Max. standard value in operation ²⁾		Radius stat. + / - 2 % (mm)	Rolling circumference ³⁾ + 1.5 % - 2.5 % (mm)
	Load Index LI	Load capacity kg		Width (mm)	Outer-Ø (mm)		
50 series							
195/50 R 15	82	475	5 ½ J	204			
195/50 R 15 XL	86	530	6 J	209	585	267	1760
			6 ½ J	214			
			7 J	219			
205/50 R 15	86	530	5 ½ J	213			
			6 J	218			
			6 ½ J	223	595	271	1790
			7 J	228			
7 ½ J	233						
185/50 R 16	81	462	5 J	192			
			5 ½ J	197			
			6 J	202	600	276	1806
			6 ½ J	207			
195/50 R 16	84	500	5 ½ J	204			
195/50 R 16 XL	88	560	6 J	209	610	279	1836
			6 ½ J	214			
			7 J	219			
205/50 R 16	87	545	5 ½ J	213			
			6 J	218			
			6 ½ J	223	620	283	1867
			7 J	228			
7 ½ J	233						
225/50 R 16	92	630	6 J	232			
			6 ½ J	237			
			7 J	242	642	291	1928
7 ½ J	247						
8 J	252						
205/50 R 17	89	580	5 ½ J	213			
205/50 R 17 XL	93	650	6 J	218			
			6 ½ J	223	646	296	1946
			7 J	228			
			7 ½ J	233			
215/50 R 17	91	615	6 J	225			
215/50 R 17 XL	95	690	6 ½ J	230			
			7 J	235	656	300	1976
			7 ½ J	240			
225/50 R 17	94	670	6 J	232			
225/50 R 17 XL	98	750	6 ½ J	237			
			7 J	242	668	304	2007
			7 ½ J	247			
			8 J	252			
235/50 R 17	96	710	6 ½ J	245			
235/50 R 17 XL	100	800	7 J	250			
			7 ½ J	255	678	308	2037
			8 J	260			
			8 ½ J	265			

Size	Tyre		Permitted rims ¹⁾ (measuring rim bold)	Tyre dimensions Max. standard value in operation ²⁾		Radius stat. + / - 2 % (mm)	Rolling circumference ³⁾ + 1.5 % - 2.5 % (mm)
	Load Index LI	Load capacity kg		Width (mm)	Outer-Ø (mm)		
50 series							
245/50 R 17	99	775	7 J	258			
			7 ½ J	263	688	312	2068
			8 J	268			
			8 ½ J	273			
215/50 R 18	92	630	6 J	225			
215/50 R 18 XL	96	710	6 ½ J	230			
			7 J	235	681	313	2053
			7 ½ J	240			
225/50 R 18	95	690	6 J	232			
225/50 R 18 XL	99	775	6 ½ J	237			
			7 J	242	693	317	2083
			7 ½ J	247			
			8 J	252			
235/50 R 18	97	730	6 ½ J	245			
235/50 R 18 XL	101	825	7 J	250			
			7 ½ J	255	703	321	2114
			8 J	260			
			8 ½ J	265			
245/50 R 18	100	800	7 J	258			
245/50 R 18 XL	104	900	7 ½ J	263	713	324	2144
			8 J	268			
			8 ½ J	273			
255/50 R 18 XL	106	950	7 J	266			
			7 ½ J	271			
			8 J	276	723	328	2175
			8 ½ J	281			
			9 J	286			
285/50 R 18	109	1030	8 J	299			
			8 ½ J	304			
			9 J	309	755	340	2266
			9 ½ J	314			
			10 J	319			
205/50 R 19 XL	94	670	5 ½ J	213			
			6 J	218			
			6 ½ J	223	697	321	2101
			7 J	228			
			7 ½ J	233			
215/50 R 19	93	650	6 J	225			
			6 ½ J	230			
			7 J	235	707	325	2132
			7 ½ J	240			
225/50 R 19 XL	100	800	6 J	232			
			6 ½ J	237			
			7 J	242	719	329	2162
			7 ½ J	247			
			8 J	252			

Size	Tyre		Permitted rims ¹⁾ (measuring rim bold)	Tyre dimensions Max. standard value in operation ²⁾		Radius stat. + / - 2 % (mm)	Rolling circumference ³⁾ + 1.5 % - 2.5 % (mm)
	Load Index LI	Load capacity kg		Width (mm)	Outer-Ø (mm)		
50 series							
235/50 R 19	99	775	6 ½ J	245			
235/50 R 19 XL	103	875	7 J	250			
			7 ½ J	255	729	334	2193
			8 J	260			
			8 ½ J	265			
245/50 R 19	101	825	7 J	258			
245/50 R 19 XL	105	925	7 ½ J	263	739	337	2223
			8 J	268			
			8 ½ J	273			
255/50 R 19	103	875	7 J	266			
255/50 R 19 XL	107	975	7 ½ J	271			
			8 J	276	749	341	2254
			8 ½ J	281			
			9 J	286			
265/50 R 19	106	950	7 ½ J	278			
265/50 R 19 XL	110	1060	8 J	283			
			8 ½ J	288	759	345	2284
			9 J	293			
			9 ½ J	298			
275/50 R 19 XL	112	1120	7 ½ J	285			
			8 J	290			
			8 ½ J	295	771	349	2315
			9 J	300			
			9 ½ J	305			
235/50 R 20	100	800	6 ½ J	245			
235/50 R 20 XL	104	900	7 J	250			
			7 ½ J	255	754	346	2269
			8 J	260			
			8 ½ J	265			
245/50 R 20	102	850	7 J	258			
245/50 R 20 XL	105	925	7 ½ J	263	764	350	2300
			8 J	268			
			8 ½ J	273			
255/50 R 20	105	925	7 J	266			
255/50 R 20 XL	109	1030	7 ½ J	271			
			8 J	276	774	354	2330
			8 ½ J	281			
			9 J	286			
265/50 R 20 XL	111	1090	7 ½ J	278			
			8 J	283			
			8 ½ J	288	784	358	2361
			9 J	294			
			9 ½ J	299			

Size	Tyre		Permitted rims ¹⁾ (measuring rim bold)	Tyre dimensions Max. standard value in operation ²⁾		Radius stat. + / - 2 % (mm)	Rolling circumference ³⁾ + 1.5 % - 2.5 % (mm)
	Load Index	Load capacity		Width (mm)	Outer-Ø (mm)		
	LI	kg					
50 series							
275/50 R 20	109	1030	7 ½ J	285			
275/50 R 20 XL	113	1150	8 J	290			
			8 ½ J	295	796	362	2391
			9 J	301			
			9 ½ J	306			
285/50 R 20	112	1120	8 J	299			
285/50 R 20 XL	116	1250	8 ½ J	304			
			9 J	309	806	366	2422
			9 ½ J	314			
			10 J	319			
295/50 R 20 XL	118	1320	8 J	306			
			8 ½ J	311			
			9 J	316			
			9 ½ J	321	816	369	2452
			10 J	326			
305/50 R 20 XL	120	1400	8 ½ J	319			
			9 J	324			
			9 ½ J	329	826	373	2483
			10 J	334			
			10 ½ J	339			
			11 J	344			
255/50 R 21 XL	109	1030	7 J	266			
			7 ½ J	271			
			8 J	276	799	366	2406
			8 ½ J	281			
			9 J	286			
275/50 R 21 XL	113	1150	7 ½ J	285			
			8 J	290			
			8 ½ J	295	821	374	2467
			9 J	301			
			9 ½ J	306			
45 series							
195/45 R 13	75	387	6 J	198			
			6 ½ J	203	514	234	1543
			7 J	208			
			7 ½ J	213			
195/45 R 14	77	412	6 J	198			
			6 ½ J	203	540	247	1623
			7 J	208			
			7 ½ J	213			
195/45 R 15	78	425	6 J	198			
			6 ½ J	203	565	259	1699
			7 J	208			
			7 ½ J	213			

Size	Tyre		Permitted rims ¹⁾ (measuring rim bold)	Tyre dimensions Max. standard value in operation ²⁾		Radius stat. + / - 2 % (mm)	Rolling circumference ³⁾ + 1.5 % - 2.5 % (mm)
	Load Index	Load capacity		Width (mm)	Outer-Ø (mm)		
	LI	kg					
45 series							
195/45 R 16	80	450	6 J	198			
195/45 R 16 XL	84	500	6 ½ J	203	590	272	1775
			7 J	208			
			7 ½ J	213			
205/45 R 16	83	487	6 ½ J	209			
205/45 R 16 XL	87	545	7 J	214	598	275	1800
			7 ½ J	219			
215/45 R 16	86	530	7 J	222	608	279	1830
215/45 R 16 XL	90	600	7 ½ J	227			
			8 J	232			
225/45 R 16	89	580	7 J	229			
			7 ½ J	234	616	282	1854
			8 J	239			
			8 ½ J	244			
245/45 R 16	94	670	7 ½ J	248			
			8 J	253	634	289	1909
			8 ½ J	258			
			9 J	263			
195/45 R 17	81	462	6 J	198			
			6 ½ J	203	616	285	1854
			7 J	208			
			7 ½ J	213			
205/45 R 17	84	500	6 ½ J	209			
205/45 R 17 XL	88	560	7 J	214	624	288	1879
			7 ½ J	219			
215/45 R 17	87	545	7 J	222	634	292	1909
215/45 R 17 XL	91	615	7 ½ J	227			
			8 J	232			
225/45 R 17	91	615	7 J	229			
225/45 R 17 XL/Rf.	94	670	7 ½ J	234	642	295	1934
			8 J	239			
			8 ½ J	244			
235/45 R 17	94	670	7 ½ J	240			
235/45 R 17 XL	97	730	8 J	245	652	299	1964
			8 ½ J	250			
			9 J	255			
245/45 R 17	95	690	7 ½ J	248			
245/45 R 17 XL	99	775	8 J	253	660	302	1989
			8 ½ J	258			
			9 J	263			
255/45 R 17	98	750	8 J	260			
255/45 R 17 XL	102	850	8 ½ J	265	672	306	2019
			9 J	270			
			9 ½ J	275			

Size	Tyre		Permitted rims ¹⁾ (measuring rim bold)	Tyre dimensions Max. standard value in operation ²⁾		Radius stat. + / - 2 % (mm)	Rolling circumference ³⁾ + 1.5 % - 2.5 % (mm)
	Load Index LI	Load capacity kg		Width (mm)	Outer-Ø (mm)		
45 series							
205/45 R 18 XL	90	600	6 ½ J	209			
			7 J	214	649	301	1955
			7 ½ J	219			
215/45 R 18 XL	93	650	7 J	222	659	304	1986
			7 ½ J	227			
			8 J	232			
225/45 R 18	91	615	7 J	229			
225/45 R 18 XL	95	690	7 ½ J	234	667	307	2010
			8 J	239			
			8 ½ J	244			
235/45 R 18	94	670	7 ½ J	240			
235/45 R 18 XL	98	750	8 J	245	677	311	2040
			8 ½ J	250			
			9 J	255			
245/45 R 18	96	710	7 ½ J	248			
245/45 R 18 XL	100	800	8 J	253	685	314	2065
			8 ½ J	258			
			9 J	263			
255/45 R 18	99	775	8 J	260			
255/45 R 18 XL	103	875	8 ½ J	265	697	318	2095
			9 J	270			
			9 ½ J	275			
265/45 R 18	101	825	8 ½ J	272			
			9 J	277	705	321	2120
			9 ½ J	282			
			10 J	287			
275/45 R 18	103	875	8 ½ J	279			
			9 J	284	715	325	2150
			9 ½ J	289			
			10 J	294			
			10 ½ J	299			
225/45 R 19	92	630	7 J	229			
225/45 R 19 XL	96	710	7 ½ J	234	693	320	2089
			8 J	239			
			8 ½ J	244			
235/45 R 19	95	690	7 ½ J	240			
235/45 R 19 XL	99	775	8 J	245	703	324	2120
			8 ½ J	250			
			9 J	255			
245/45 R 19	98	750	7 ½ J	248			
245/45 R 19 XL	102	850	8 J	253	711	327	2144
			8 ½ J	258			
			9 J	263			

Size	Tyre		Permitted rims ¹⁾ (measuring rim bold)	Tyre dimensions Max. standard value in operation ²⁾		Radius stat. + / - 2 % (mm)	Rolling circumference ³⁾ + 1.5 % - 2.5 % (mm)
	Load Index LI	Load capacity kg		Width (mm)	Outer-Ø (mm)		
45 series							
255/45 R 19	100	800	8 J	260			
255/45 R 19 XL	104	900	8 ½ J	265	723	331	2175
			9 J	270			
			9 ½ J	275			
265/45 R 19 XL	105	925	8 ½ J	272			
			9 J	277	731	334	2199
			9 ½ J	282			
			10 J	287			
275/45 R 19 XL	108	1000	8 ½ J	279			
			9 J	284	741	338	2230
			9 ½ J	289			
			10 J	294			
			10 ½ J	299			
285/45 R 19	107	975	9 J	291			
285/45 R 19 XL	111	1090	9 ½ J	296	749	341	2254
			10 J	301			
			10 ½ J	306			
295/45 R 19	109	1030	9 ½ J	302			
			10 J	308	759	345	2284
			10 ½ J	312			
			11 J	317			
215/45 R 20 XL	95	690	7 J	222	710	329	2141
			7 ½ J	227			
			8 J	232			
235/45 R 20 XL	100	800	7 ½ J	241			
			8 J	245	728	336	2196
			8 ½ J	251			
			9 J	256			
245/45 R 20	99	775	7 ½ J	248			
245/45 R 20 XL	103	875	8 J	253	736	340	2220
			8 ½ J	258			
			9 J	263			
255/45 R 20	101	825	8 J	260			
255/45 R 20 XL	105	925	8 ½ J	265	748	344	2251
			9 J	270			
			9 ½ J	275			
265/45 R 20	104	900	8 ½ J	272			
265/45 R 20 XL	108	1000	9 J	277	756	347	2275
			9 ½ J	282			
			10 J	287			
275/45 R 20 XL	110	1060	8 ½ J	279			
			9 J	284	766	351	2306
			9 ½ J	289			
			10 J	294			
			10 ½ J	299			

Size	Tyre		Permitted rims ¹⁾ (measuring rim bold)	Tyre dimensions Max. standard value in operation ²⁾		Radius stat. + / - 2 % (mm)	Rolling circumference ³⁾ + 1.5 % - 2.5 % (mm)
	Load Index	Load capacity		Width (mm)	Outer-Ø (mm)		
	LI	kg					
45 series							
285/45 R 20 XL	112	1120	9 J	291			
			9 ½ J	296	774	354	2330
			10 J	301			
			10 ½ J	306			
295/45 R 20 XL	114	1180	9 ½ J	303			
			10 J	308	784	358	2361
			10 ½ J	313			
			11 J	318			
245/45 R 21 XL	104	900	7 ½ J	248			
			8 J	253	761	353	2297
			8 ½ J	258			
			9 J	263			
255/45 R 21 XL	105	925	8 J	260			
			8 ½ J	265	773	356	2327
			9 J	270			
			9 ½ J	275			
265/45 R 21 XL	108	1000	8 ½ J	272			
			9 J	277	781	359	2352
			9 ½ J	282			
			10 J	287			
275/45 R 21	107	975	8 ½ J	279			
275/45 R 21 XL	110	1060	9 J	284	791	363	2382
			9 ½ J	289			
			10 J	294			
			10 ½ J	299			
285/45 R 21	109	1030	9 J	291			
285/45 R 21 XL	113	1150	9 ½ J	296	799	366	2406
			10 J	301			
			10 ½ J	306			
315/45 R 21	116	1250	10 ½ J	328	829	377	2492
			11 J	333			
			11 ½ J	338			
255/45 R 22 XL	107	975	8 J	260			
			8 ½ J	265	799	369	2406
			9 J	270			
			9 ½ J	275			
275/45 R 22 XL	112	1120	8 ½ J	279			
275/45 R 22 XL+	115	1215	9 J	284	817	376	2461
			9 ½ J	289			
			10 J	294			
			10 ½ J	299			
285/45 R 22 XL	114	1180	9 J	291			
			9 ½ J	296	825	379	2486
			10 J	301			
			10 ½ J	306			

Size	Tyre		Permitted rims ¹⁾ (measuring rim bold)	Tyre dimensions Max. standard value in operation ²⁾		Radius stat. + / - 2 % (mm)	Rolling circumference ³⁾ + 1.5 % - 2.5 % (mm)
	Load Index	Load capacity		Width (mm)	Outer-Ø (mm)		
	LI	kg					
45 series							
305/45 R 22 XL	118	1320	9 ½ J	310			
			10 J	315	843	386	2541
			10 ½ J	320			
			11 J	325			
			11 ½ J	330			
40 series							
195/40 R 14	73	365	6 ½ J	203			
			7 J	208	518	239	1562
			7 ½ J	213			
195/40 R 16 XL	80	450	6 ½ J	203			
			7 J	208	568	264	1714
			7 ½ J	213			
215/40 R 16 XL	86	530	7 J	222			
			7 ½ J	227	584	270	1763
			8 J	232			
			8 ½ J	237			
225/40 R 16	85	515	7 ½ J	234			
			8 J	239	594	273	1787
			8 ½ J	244			
			9 J	249			
195/40 R 17 XL	81	462	6 ½ J	203			
			7 J	208	594	277	1793
			7 ½ J	213			
205/40 R 17 XL	84	500	7 J	215			
			7 ½ J	220	602	280	1818
			8 J	225			
215/40 R 17	83	487	7 J	222			
215/40 R 17 XL	87	545	7 ½ J	227	610	283	1842
			8 J	232			
			8 ½ J	237			
235/40 R 17	90	600	8 J	246			
			8 ½ J	251	628	289	1891
			9 J	256			
			9 ½ J	261			
245/40 R 17	91	615	8 J	253			
245/40 R 17 XL	95	690	8 ½ J	258	636	292	1915
			9 J	263			
			9 ½ J	268			
255/40 R 17	94	670	8 ½ J	265			
255/40 R 17 XL	98	750	9 J	270	644	296	1940
			9 ½ J	275			
			10 J	280			
205/40 R 18 XL	86	530	7 J	215			
			7 ½ J	220	627	292	1894
			8 J	225			

Size	Tyre		Permitted rims ¹⁾ (measuring rim bold)	Tyre dimensions Max. standard value in operation ²⁾		Radius stat. + / - 2 % (mm)	Rolling circumference ³⁾ + 1.5 % - 2.5 % (mm)
	Load Index LI	Load capacity kg		Width (mm)	Outer-Ø (mm)		
40 series							
215/40 R 18	85	515	7 J	222			
215/40 R 18 XL	89	580	7 ½ J	227	635	296	1918
			8 J	232			
			8 ½ J	237			
225/40 R 18	88	560	7 ½ J	234			
225/40 R 18 XL	92	630	8 J	239	645	299	1943
			8 ½ J	244			
			9 J	249			
235/40 R 18	91	615	8 J	246			
235/40 R 18 XL	95	690	8 ½ J	251	653	302	1967
			9 J	256			
			9 ½ J	261			
245/40 R 18	93	650	8 J	253			
245/40 R 18 XL	97	730	8 ½ J	258	661	305	1992
			9 J	263			
			9 ½ J	268			
255/40 R 18	95	690	8 ½ J	265			
255/40 R 18 XL	99	775	9 J	270	669	308	2016
			9 ½ J	275			
			10 J	280			
265/40 R 18 XL	101	825	9 J	277			
			9 ½ J	282	677	311	2040
			10 J	287			
			10 ½ J	292			
275/40 R 18	99	775	9 J	284			
275/40 R 18 XL	103	875	9 ½ J	289	685	314	2065
			10 J	294			
			10 ½ J	299			
			11 J	304			
225/40 R 19	89	580	7 ½ J	234			
225/40 R 19 XL	93	650	8 J	239	671	312	2022
			8 ½ J	244			
			9 J	249			
235/40 R 19	92	630	8 J	246			
235/40 R 19 XL	96	710	8 ½ J	251	679	315	2047
			9 J	256			
			9 ½ J	261			
245/40 R 19	94	670	8 J	253			
245/40 R 19 XL	98	750	8 ½ J	258	687	318	2071
245/40 R 19 XL+	101	825	9 J	263			
			9 ½ J	268			
255/40 R 19	96	710	8 ½ J	265			
255/40 R 19 XL	100	800	9 J	270	695	321	2095
			9 ½ J	275			
			10 J	280			

Size	Tyre		Permitted rims ¹⁾ (measuring rim bold)	Tyre dimensions Max. standard value in operation ²⁾		Radius stat. + / - 2 % (mm)	Rolling circumference ³⁾ + 1.5 % - 2.5 % (mm)
	Load Index LI	Load capacity kg		Width (mm)	Outer-Ø (mm)		
40 series							
265/40 R 19	98	750	9 J	277			
265/40 R 19 XL	102	850	9 ½ J	282	703	324	2120
			10 J	287			
			10 ½ J	292			
275/40 R 19	101	825	9 J	284			
275/40 R 19 XL	105	925	9 ½ J	289	711	327	2144
			10 J	294			
			10 ½ J	299			
			11 J	304			
285/40 R 19	103	875	9 ½ J	296			
285/40 R 19 XL	107	975	10 J	302	721	330	2169
			10 ½ J	307			
			11 J	312			
295/40 R 19 XL	108	1000	10 J	308			
			10 ½ J	313	729	334	2193
			11 J	318			
			11 ½ J	323			
225/40 R 20 XL	94	580	7 ½ J	234			
			8 J	239	696	324	2098
			8 ½ J	244			
			9 J	249			
235/40 R 20 XL	96	710	8 J	246			
			8 ½ J	251	704	327	2123
			9 J	256			
			9 ½ J	261			
245/40 R 20	95	690	8 J	253			
245/40 R 20 XL	99	775	8 ½ J	258	712	330	2147
			9 J	263			
			9 ½ J	268			
255/40 R 20	97	730	8 ½ J	265			
255/40 R 20 XL	101	825	9 J	270	720	334	2172
			9 ½ J	275			
			10 J	280			
265/40 R 20 XL	104	900	9 J	277			
			9 ½ J	282	728	337	2196
			10 J	288			
			10 ½ J	293			
275/40 R 20 XL	106	950	9 J	284			
			9 ½ J	289	736	340	2220
			10 J	294			
			10 ½ J	299			
			11 J	304			
285/40 R 20	104	900	9 ½ J	296			
285/40 R 20 XL	108	1000	10 J	302	746	343	2245
			10 ½ J	307			
			11 J	312			

Size	Tyre		Permitted rims ¹⁾ (measuring rim bold)	Tyre dimensions Max. standard value in operation ²⁾		Radius stat. + / - 2 % (mm)	Rolling circumference ³⁾ + 1.5 % - 2.5 % (mm)
	Load Index LI	Load capacity kg		Width (mm)	Outer-Ø (mm)		
40 series							
295/40 R 20	106	950	10 J	308			
295/40 R 20 XL	110	1060	10 ½ J	313	754	346	2269
			11 J	318			
			11 ½ J	323			
305/40 R 20 XL	112	1120	10 J	316			
			10 ½ J	321			
			11 J	326	762	349	2294
			11 ½ J	331			
			12 J	336			
245/40 R 21 XL	100	800	8 J	253			
			8 ½ J	258	737	343	2223
			9 J	263			
			9 ½ J	268			
255/40 R 21 XL	102	850	8 ½ J	265			
			9 J	270	745	346	2248
			9 ½ J	275			
			10 J	280			
265/40 R 21	101	825	9 J	277			
265/40 R 21 XL	105	925	9 ½ J	282	753	349	2272
			10 J	288			
			10 ½ J	293			
275/40 R 21 XL	107	975	9 J	284			
			9 ½ J	289	761	352	2297
			10 J	294			
			10 ½ J	299			
			11 J	304			
285/40 R 21 XL	109	1030	9 ½ J	297			
			10 J	302	771	355	2321
			10 ½ J	307			
			11 J	312			
295/40 R 21 XL	111	1090	10 J	307			
			10 ½ J	313	779	359	2345
			11 J	318			
			11 ½ J	324			
315/40 R 21	111	1090	10 ½ J	328			
315/40 R 21 XL	115	1215	11 J	333	795	365	2394
			11 ½ J	338			
			12 J	343			
			12 ½ J	348			
325/40 R 21	113	1150	11 J	339			
			11 ½ J	344	803	368	2419
			12 J	349			
			12 ½ J	354			
			13 J	359			

Size	Tyre		Permitted rims ¹⁾ (measuring rim bold)	Tyre dimensions Max. standard value in operation ²⁾		Radius stat. + / - 2 % (mm)	Rolling circumference ³⁾ + 1.5 % - 2.5 % (mm)
	Load Index LI	Load capacity kg		Width (mm)	Outer-Ø (mm)		
40 series							
255/40 R 22 XL	103	875	8 ½ J	265			
			9 J	270	771	359	2327
			9 ½ J	275			
			10 J	280			
265/40 R 22 XL	106	950	9 J	277			
			9 ½ J	282	779	362	2352
			10 J	288			
			10 ½ J	293			
275/40 R 22 XL	107	975	9 J	284			
	108	1000	9 ½ J	289	787	365	2376
			10 J	294			
			10 ½ J	299			
			11 J	304			
285/40 R 22	106	950	9 ½ J	297			
285/40 R 22 XL	110	1060	10 J	302	797	368	2400
			10 ½ J	307			
			11 J	312			
295/40 R 22 XL	112	1120	10 J	308			
			10 ½ J	313	805	372	2425
			11 J	318			
			11 ½ J	323			
305/40 R 22 XL	114	1180	10 J	316			
			10 ½ J	321			
			11 J	326	813	375	2449
			11 ½ J	331			
			12 J	336			
325/40 R 22	114	1180	11 J	339			
			11 ½ J	344	829	381	2498
			12 J	349			
			12 ½ J	354			
			13 J	359			
265/40 R 23 XL	106	950	9 J	277			
			9 ½ J	282	804	375	2428
			10 J	287			
			10 ½ J	292			
285/40 R 23 XL	111	1090	9 ½ J	297			
			10 J	302	822	381	2477
			10 ½ J	307			
			11 J	312			
305/40 R 23 XL	115	1215	10 J	316			
			10 ½ J	321			
			11 J	326	838	387	2525
			11 ½ J	331			
			12 J	336			

Size	Tyre		Permitted rims ¹⁾ (measuring rim bold)	Tyre dimensions Max. standard value in operation ²⁾		Radius stat. + / - 2 % (mm)	Rolling circumference ³⁾ + 1.5 % - 2.5 % (mm)
	Load Index	Load capacity		Width (mm)	Outer-Ø (mm)		
	LI	kg					
40 series							
285/40 R 24 XL	112	1120	9 ½ J	296			
			10 J	302	848	394	2556
			10 ½ J	307			
			11 J	312			
305/40 R 24 XL	117	1285	10 J	316			
			10 ½ J	321			
			11 J	326	864	400	2605
			11 ½ J	331			
			12 J	336			
35 series							
215/35 R 17 XL	83	487	7 J	222			
			7 ½ J	227	588	275	1775
			8 J	232			
			8 ½ J	237			
245/35 R 17	87	545	8 J	253			
			8 ½ J	258	610	283	1842
			9 J	263			
			9 ½ J	268			
215/35 R 18 XL	84	500	7 J	222			
			7 ½ J	227	613	287	1851
			8 J	232			
			8 ½ J	237			
225/35 R 18 XL	87	545	7 ½ J	234			
			8 J	239	621	290	1876
			8 ½ J	244			
			9 J	249			
245/35 R 18	88	560	8 J	253			
245/35 R 18 XL	92	630	8 ½ J	258	635	296	1918
			9 J	263			
			9 ½ J	268			
255/35 R 18	90	600	8 ½ J	265			
255/35 R 18 XL	94	670	9 J	270	643	298	1937
			9 ½ J	275			
			10 J	280			
265/35 R 18	93	650	9 J	277			
265/35 R 18 XL	97	730	9 ½ J	282	651	301	1961
			10 J	287			
			10 ½ J	292			
275/35 R 18	95	690	9 J	284			
275/35 R 18 XL	99	775	9 ½ J	289	657	303	1979
			10 J	294			
			10 ½ J	299			
			11 J	304			

Size	Tyre		Permitted rims ¹⁾ (measuring rim bold)	Tyre dimensions Max. standard value in operation ²⁾		Radius stat. + / - 2 % (mm)	Rolling circumference ³⁾ + 1.5 % - 2.5 % (mm)
	Load Index	Load capacity		Width (mm)	Outer-Ø (mm)		
	LI	kg					
35 series							
285/35 R 18	97	730	9 ½ J	297			
285/35 R 18 XL	101	825	10 J	302	665	307	2004
			10 ½ J	307			
			11 J	312			
215/35 R 19 XL	85	515	7 J	222			
			7 ½ J	227	639	300	1931
			8 J	232			
			8 ½ J	237			
225/35 R 19 XL	88	560	7 ½ J	234			
			8 J	239	647	303	1955
			8 ½ J	244			
			9 J	249			
235/35 R 19	87	545	8 J	246			
235/35 R 19 XL	91	615	8 ½ J	251	653	305	1973
			9 J	256			
			9 ½ J	261			
245/35 R 19 XL	93	650	8 J	253			
			8 ½ J	258	661	309	1998
			9 J	263			
			9 ½ J	268			
255/35 R 19	92	630	8 ½ J	265			
255/35 R 19 XL	96	710	9 J	270	669	311	2016
			9 ½ J	275			
			10 J	280			
265/35 R 19	94	670	9 J	277			
265/35 R 19 XL	98	750	9 ½ J	282	677	314	2040
			10 J	287			
			10 ½ J	292			
275/35 R 19 XL	100	800	9 J	284			
			9 ½ J	289	683	316	2059
			10 J	294			
			10 ½ J	299			
			11 J	304			
285/35 R 19	99	775	9 ½ J	297			
285/35 R 19 XL	103	875	10 J	302	691	320	2083
			10 ½ J	307			
			11 J	312			
295/35 R 19	100	800	10 J	308			
295/35 R 19 XL	104	900	10 ½ J	313	697	322	2101
			11 J	318			
			11 ½ J	323			
225/35 R 20 XL	90	600	7 ½ J	234			
			8 J	239	672	316	2031
			8 ½ J	244			
			9 J	249			

Size	Tyre		Permitted rims ¹⁾ (measuring rim bold)	Tyre dimensions Max. standard value in operation ²⁾		Radius stat. + / - 2 % (mm)	Rolling circumference ³⁾ + 1.5 % - 2.5 % (mm)
	Load Index LI	Load capacity kg		Width (mm)	Outer-Ø (mm)		
35 series							
235/35 R 20	88	560	8 J	246			
235/35 R 20 XL	92	630	8 ½ J	251	678	318	2050
			9 J	256			
			9 ½ J	261			
245/35 R 20	91	615	8 J	253			
245/35 R 20 XL	95	690	8 ½ J	258	686	321	2074
			9 J	263			
			9 ½ J	268			
255/35 R 20 XL	97	730	8 ½ J	265			
			9 J	270	694	323	2092
			9 ½ J	275			
			10 J	280			
265/35 R 20	95	690	9 J	277			
265/35 R 20 XL	99	775	9 ½ J	282	702	327	2117
			10 J	287			
			10 ½ J	292			
275/35 R 20 XL	102	850	9 J	284			
			9 ½ J	289	708	329	2135
			10 J	294			
			10 ½ J	299			
			11 J	304			
285/35 R 20	100	800	9 ½ J	296			
285/35 R 20 XL	104	900	10 J	302	716	332	2159
			10 ½ J	307			
			11 J	312			
295/35 R 20	101	825	10 J	308			
295/35 R 20 XL	105	925	10 ½ J	313	722	334	2178
			11 J	318			
			11 ½ J	323			
315/35 R 20 XL	110	1060	10 ½ J	328			
			11 J	333	736	340	2220
			11 ½ J	338			
			12 J	343			
			12 ½ J	348			
325/35 R 20	108	1000	11 J	339			
			11 ½ J	344	746	343	2245
			12 J	349			
			12 ½ J	354			
			13 J	359			
245/35 R 21 XL	96	710	8 J	253			
			8 ½ J	258	711	334	2150
			9 J	263			
			9 ½ J	268			

Size	Tyre		Permitted rims ¹⁾ (measuring rim bold)	Tyre dimensions Max. standard value in operation ²⁾		Radius stat. + / - 2 % (mm)	Rolling circumference ³⁾ + 1.5 % - 2.5 % (mm)
	Load Index LI	Load capacity kg		Width (mm)	Outer-Ø (mm)		
35 series							
255/35 R 21 XL	98	750	8 ½ J	265			
			9 J	270	719	336	2169
			9 ½ J	275			
			10 J	280			
265/35 R 21 XL	101	825	9 J	277			
			9 ½ J	282	727	339	2193
			10 J	287			
			10 ½ J	292			
275/35 R 21 XL	103	875	9 J	284			
			9 ½ J	289	733	341	2211
			10 J	294			
			10 ½ J	299			
			11 J	304			
285/35 R 21 XL	105	925	9 ½ J	296			
			10 J	302	741	345	2236
			10 ½ J	307			
			11 J	312			
295/35 R 21	103	875	10 J	308			
295/35 R 21 XL	107	975	10 ½ J	313	747	347	2254
			11 J	318			
			11 ½ J	324			
305/35 R 21 XL	109	1030	10 J	316			
			10 ½ J	321			
			11 J	326	755	350	2278
			11 ½ J	331			
			12 J	336			
315/35 R 21 XL	111	1090	10 ½ J	328			
			11 J	333	761	353	2297
			11 ½ J	338			
			12 J	343			
			12 ½ J	348			
265/35 R 22 XL	102	850	9 J	277			
			9 ½ J	282	753	352	2272
			10 J	287			
			10 ½ J	292			
275/35 R 22 XL	104	900	9 J	284			
			9 ½ J	289	759	354	2291
			10 J	294			
			10 ½ J	300			
			11 J	305			
285/35 R 22 XL	106	950	9 ½ J	296			
			10 J	302	767	358	2315
			10 ½ J	307			
			11 J	312			

Size	Tyre		Permitted rims ¹⁾ (measuring rim bold)	Tyre dimensions Max. standard value in operation ²⁾		Radius stat. + / - 2 % (mm)	Rolling circumference ³⁾ + 1.5 % - 2.5 % (mm)
	Load Index	Load capacity		Width (mm)	Outer-Ø (mm)		
	LI	kg					
35 series							
295/35 R 22 XL	108	1000	10 J	308			
			10 ½ J	313	773	360	2333
			11 J	318			
			11 ½ J	323			
315/35 R 22 XL	111	1090	10 ½ J	328			
			11 J	333	787	365	2376
			11 ½ J	338			
			12 J	343			
			12 ½ J	348			
325/35 R 22	110	1060	11 J	339			
325/35 R 22 XL	114	1180	11 ½ J	344	797	368	2400
			12 J	349			
			12 ½ J	354			
			13 J	359			
285/35 R 23 XL	107	975	9 ½ J	296			
			10 J	302	792	370	2391
			10 ½ J	307			
			11 J	312			
295/35 R 23 XL	108	1000	10 J	308			
			10 ½ J	313	798	372	2410
			11 J	318			
			11 ½ J	323			
305/35 R 23 XL	111	1090	10 J	316			
			10 ½ J	321			
			11 J	326	806	375	2434
			11 ½ J	331			
295/35 R 24 XL	110	1060	10 J	308			
			10 ½ J	313	824	385	2489
			11 J	318			
			11 ½ J	323			
305/35 R 24 XL	112	1120	10 J	316			
			10 ½ J	321			
			11 J	326	832	388	2513
			11 ½ J	331			
			12 J	336			
315/35 R 24 XL	114	1180	10 ½ J	328			
			11 J	333	838	391	2532
			11 ½ J	338			
			12 J	343			
			12 ½ J	348			
30 series							
255/30 R 18 XL	90	600	8 ½ J	265			
			9 J	270	617	289	1864
			9 ½ J	275			

Size	Tyre		Permitted rims ¹⁾ (measuring rim bold)	Tyre dimensions Max. standard value in operation ²⁾		Radius stat. + / - 2 % (mm)	Rolling circumference ³⁾ + 1.5 % - 2.5 % (mm)
	Load Index	Load capacity		Width (mm)	Outer-Ø (mm)		
	LI	kg					
30 series							
285/30 R 18	93	650	9 ½ J	297			
			10 J	302	635	296	1918
			10 ½ J	307			
295/30 R 18	94	670	10 J	308			
295/30 R 18 XL	98	750	10 ½ J	313	643	298	1937
			11 J	318			
245/30 R 19 XL	89	580	8 J	253			
			8 ½ J	258	637	299	1925
			9 J	263			
255/30 R 19 XL	91	615	8 ½ J	265			
			9 J	270	643	302	1943
			9 ½ J	275			
265/30 R 19 XL	93	650	9 J	277			
			9 ½ J	282	649	304	1961
			10 J	287			
275/30 R 19 XL	96	710	9 J	284			
			9 ½ J	289	655	306	1979
			10 J	294			
285/30 R 19 XL	98	750	9 ½ J	297			
			10 J	302	661	309	1998
			10 ½ J	307			
295/30 R 19	96	710	10 J	308			
295/30 R 19 XL	100	800	10 ½ J	313	669	311	2016
			11 J	318			
305/30 R 19 XL	102	850	10 ½ J	321			
			11 J	326	675	313	2034
			11 ½ J	331			
325/30 R 19 XL	105	925	11 J	339			
			11 ½ J	344	687	318	2071
			12 J	349			
225/30 R 20 XL	85	515	8 J	239	650	307	1964
235/30 R 20 XL	88	560	8 ½ J	251	656	309	1983
245/30 R 20 XL	90	600	8 J	253			
			8 ½ J	258	662	312	2001
			9 J	263			
255/30 R 20 XL	92	630	8 ½ J	265			
			9 J	270	668	314	2019
			9 ½ J	275			
265/30 R 20 XL	94	670	9 J	277			
			9 ½ J	282	674	316	2037
			10 J	287			
275/30 R 20 XL	97	730	9 J	284			
			9 ½ J	289	680	319	2056
			10 J	294			

Size	Tyre		Permitted rims ¹⁾ (measuring rim bold)	Tyre dimensions Max. standard value in operation ²⁾		Radius stat. + / - 2 % (mm)	Rolling circumference ³⁾ + 1.5 % - 2.5 % (mm)
	Load Index LI	Load capacity kg		Width (mm)	Outer-Ø (mm)		
30 series							
285/30 R 20 XL	99	775	9 ½ J	297	686	321	2074
			10 J	302			
			10 ½ J	307			
295/30 R 20 XL	101	825	10 J	308	694	323	2092
			10 ½ J	313			
			11 J	318			
305/30 R 20 XL	103	875	10 ½ J	321	700	326	2111
			11 J	326			
			11 ½ J	331			
325/30 R 20 XL	106	950	11 J	339	712	330	2147
			11 ½ J	344			
			12 J	349			
335/30 R 20 XL	108	1000	11 ½ J	352	718	333	2166
			12 J	357			
			12 ½ J	362			
245/30 R 21 XL	91	615	8 J	253	687	324	2077
			8 ½ J	258			
			9 J	263			
255/30 R 21 XL	93	650	8 ½ J	265	693	327	2095
			9 J	270			
			9 ½ J	275			
265/30 R 21 XL	96	710	9 J	277	699	329	2114
			9 ½ J	282			
			10 J	287			
275/30 R 21 XL	98	750	9 J	284	705	331	2132
			9 ½ J	289			
			10 J	294			
285/30 R 21 XL	100	800	9 ½ J	297	711	334	2150
			10 J	302			
			10 ½ J	307			
295/30 R 21 XL	102	850	10 J	308	719	336	2169
			10 ½ J	313			
			11 J	318			
305/30 R 21	100	800	10 ½ J	321	725	338	2187
			11 J	326			
			11 ½ J	331			
315/30 R 21 XL	105	925	10 ½ J	328	731	341	2205
			11 J	333			
			11 ½ J	338			
325/30 R 21 XL	108	1000	11 J	339	737	343	2223
			11 ½ J	344			
			12 J	349			
255/30 R 22 XL	95	690	8 ½ J	265	719	339	2175
			9 J	270			
			9 ½ J	275			
265/30 R 22 XL	97	730	9 J	277	725	342	2193
			9 ½ J	282			
			10 J	287			
285/30 R 22 XL	101	825	9 ½ J	297	737	347	2230
			10 J	302			
			10 ½ J	307			

Size	Tyre		Permitted rims ¹⁾ (measuring rim bold)	Tyre dimensions Max. standard value in operation ²⁾		Radius stat. + / - 2 % (mm)	Rolling circumference ³⁾ + 1.5 % - 2.5 % (mm)
	Load Index LI	Load capacity kg		Width (mm)	Outer-Ø (mm)		
30 series							
295/30 R 22 XL	103	875	10 J	308	745	349	2248
			10 ½ J	313			
			11 J	318			
315/30 R 22 XL	107	975	10 ½ J	328	757	354	2284
			11 J	333			
			11 ½ J	338			
305/30 R 23 XL	105	925	10 ½ J	321	776	364	2342
			11 J	326			
			11 ½ J	331			
335/30 R 23 XL	111	1090	11 ½ J	352	794	371	2397
			12 J	357			
			12 ½ J	362			
295/30 R 24 XL+	108	1000	10 J	308	796	374	2403
			10 ½ J	313			
			11 J	318			
335/30 R 24 XL	112	1120	11 ½ J	352	820	383	2477
			12 J	357			
			12 ½ J	362			
25 series							
315/25 R 19 XL	98	750	11 J	333	647	303	1955
			11 ½ J	338			
			12 J	343			
285/25 R 20 XL	93	650	10 ½ J	307	656	309	1983
295/25 R 20 XL	95	690	10 J	308	662	312	2001
			10 ½ J	313			
			11 J	318			
305/25 R 20 XL	97	730	10 ½ J	321	666	313	2013
			11 J	326			
			11 ½ J	331			
325/25 R 20 XL	101	825	11 ½ J	344	676	317	2044
			12 J	349			
			12 ½ J	355			
275/25 R 21 XL	92	630	10 J	294	677	320	2047
295/25 R 21 XL	96	710	10 J	308	687	324	2077
			10 ½ J	313			
			11 J	318			
305/25 R 21 XL	98	750	10 ½ J	321	691	326	2089
			11 J	326			
			11 ½ J	331			
325/25 R 21 XL	102	850	11 ½ J	344	701	330	2120
			12 J	349			
			12 ½ J	354			
295/25 R 22 XL	97	730	10 J	308	713	337	2156
			10 ½ J	313			
			11 J	318			
305/25 R 22 XL	99	775	10 ½ J	320	717	339	2169
			11 J	326			
			11 ½ J	331			
335/25 R 22 XL	105	925	11 ½ J	351	733	345	2217
			12 J	357			
			12 ½ J	362			
315/25 R 23 XL	102	850	11 J	333	748	354	2263
			11 ½ J	338			
			12 J	343			

Tyre			Tyre dimensions				Rolling circumference	Load Index	Wheel position ⁹⁾	Load capacity (kg) per axle at a tyre pressure (bar)							
Size	Load Range	Load Index	Max. standard value in operation ²⁾			New tire on measuring rim				LI	2.5	3.0	3.5	4.0	4.5	5.0	5.5
			Permitted rims ¹⁾ (measuring rim bold)	Width (mm)	Outer-Ø (mm)												
	LR ^{**)}	LI															
LT sizes																	
15 inch																	
LT 215/80 R 15	LRE	112/109	5 ½J, 6J , 6 ½J, 7J	229	745	216	2215	112 109	S T	1300 2360	1480 2700	1650 3000	1810 3300	1950 3500	2120 3860	2240 4120	
LT 215/75 R 15	LRD	106/103	5 ½J, 6J , 6 ½J, 7J	229	723	216	2148	106 103	S T	1250 2280	1420 2580	1600 2920	1740 3160	1900 3500			
LT 235/75 R 15	LRD	110/107	6J, 6 ½J , 7J	249	753	235	2239	110 107	S T	1420 2580	1620 2940	1800 3300	1980 3600	2120 3900			
LT 245/75 R 15	LRD	113/110	6 ½J, 7J , 7 ½J	263	769	248	2288	113 110	S T	1520 2760	1730 3140	1950 3500	2120 3860	2300 4240			
LT 205/70 R 15	LRE	107/103	5J, 5 ½J, 6J , 6 ½J, 7J	222	687	209	2045	107 103	S T	1120 2040	1270 2320	1420 2600	1550 2820	1700 3100	1820 3320	1950 3500	
16 inch																	
LT 215/85 R 16	LRE	115/112	5 ½J, 6J , 6 ½J, 7J	229	793	216	2357	115 112	S T	1390 2520	1580 2880	1760 3200	1930 3480	2120 3900	2260 4120	2430 4480	
LT 235/85 R 16	LRE	120/116	6J, 6 ½J , 7J, 7 ½J	249	828	235	2460	120 116	S T	1580 2880	1800 3280	2000 3640	2200 4000	2380 4320	2580 4680	2760 5040	
LT 225/75 R 16	LRD	110/107	6J , 6 ½J, 7J	236	764	223	2273	110	S	1400	1590	1760	1940	2120			
	LRE	115/112						107	T	2540	2900	3200	3540	3900			
								115	S	1400	1590	1760	1940	2120	2280	2430	
LT 245/75 R 16	LRE	120/116	6 ½J, 7J , 7 ½J, 8J	263	795	248	2363	112	S	1580	1800	2000	2200	2380	2580	2760	
								116	T	2880	3280	3640	4000	4320	4680	5040	
LT 265/75 R 16	LRC	112/109	7J, 7 ½J , 8J	283	826	267	2454	112	S	1780	2020	2240					
		109						T	3240	3680	4120						
	LRE	119/116						116	S	1780	2020	2240	2480	2720			
		123/120						116	T	3240	3680	4120	4520	5000			
123	S	1780	2020	2240	2480	2720	2880	3100									
120	T	3240	3680	4120	4520	5000	5240	5600									
LT 285/75 R 16	LRC	116/113	7 ½J, 8J , 8 ½J, 9J	303	858	286	2545	116	S	1980	2260	2500					
		121/118						113	T	3600	4120	4600					
		LRE						122/119	121	S	****	****	****	****	****		
	118								T	****	****	****	****	****			
	122								S	1980	2260	2500	2760	3000			
	LRE	126/123						119	T	3600	4120	4600	5040	5440			
126			S	1980	2260	2500	2760	3000	3220	3400							
123	T	3600	4120	4600	5040	5440	5880	6200									
LT 295/75 R 16	LRD	123/120	7 ½J, 8J , 8 ½J, 9J, 9 ½J	312	872	294	2588	123 120	S T	2080 3780	2360 4280	2640 4860	2900 5280	3100 5600			
LT 315/75 R 16	LRD	121	8J, 8 ½J , 9J, 9 ½J, 10J, 10 ½J, 11J	332	904	313	2679	121	S	2300	2620	2900					
		LRE						127/124	127	S	2300	2620	2900	3200	3500		
									124	T	4240	4760	5280	5840	6400		
LT 235/70 R 16	LRD	110/107	6J, 6 ½J, 7J , 7 ½J	254	756	240	2248	110	S	1420	1610	1800	1970	2120			
								107	T	2580	2940	3300	3580	3900			

***) Load Range, standardized according to TRA (Tire and Rim Association, USA). Classifies the max. load capacity of a tyre, corresponding PR. LR B equals 4 PR, LR C - 6 PR, LR D - 8 PR, LR E - 10 PR.

Tyre			Tyre dimensions				Rolling circumference	Load Index	Wheel position ⁹⁾	Load capacity (kg) per axle at a tyre pressure (bar)							
Size	Load Range	Load Index	Max. standard value in operation ²⁾			New tire on measuring rim				LI	2.5	3.0	3.5	4.0	4.5	5.0	5.5
			Permitted rims ¹⁾ (measuring rim bold)	Width (mm)	Outer-Ø (mm)												
	LR ^{**)}	LI															
LT sizes																	
16 inch																	
LT 245/70 R 16	LRD	113/110	6 ½J, 7J , 7 ½J	263	770	248	2291	113 110	S T	1510 2740	1710 3120	1900 3500	2100 3820	2300 4240			
LT 255/70 R 16	LRE	120/117	6 ½J, 7J, 7 ½J , 8J	276	784	260	2333	120 117	S T	1600 2920	1820 3320	2000 3600	2220 4040	2450 4480	2600 4720	2800 5140	
LT 265/70 R 16	LRE	121/118	7J, 7 ½J, 8J , 8 ½J	288	800	272	2376	121 118	S T	1690 3080	1920 3500	2120 3900	2360 4280	2570 4720	2740 5000	2900 5280	
LT 305/70 R 16	LRD	118/115	8J, 8 ½J, 9J , 9 ½J	330	858	311	2545	118	S	2060	2380	2640					
	LRE	124/121						115	T	3700	4320	4860					
								124 121	S T	2060 3700	2380 4320	2640 4860	2900 5280	3200 5800			
LT 215/65 R 16	LRD	103/100	6J, 6 ½J , 7J	234	704	221	2097	103 100	S T	1160 2120	1330 2420	1500 2760	1630 2960	1750 3200			
17 inch																	
LT 235/80 R 17	LRE	120/117	6J, 6 ½J , 7J, 7 ½J	249	830	235	2466	120 117	S T	1600 2920	1820 3320	2060 3700	2220 4040	2430 4480	2600 4720	2800 5140	
LT 245/75 R 17	LRE	121/118	6 ½J, 7J , 7 ½J	263	820	248	2442	121 118	S T	1650 3000	1870 3400	2060 3700	2280 4160	2500 4600	2680 4880	2900 5280	
LT 255/75 R 17	LRE	111/108	6 ½ J, 7J , 7 ½J, 8J, 8 ½J	270	836	255	2485	111 108	S T	1740 3160	1980 3600	2180 4000					
LT 225/70 R 17	LRE	115/112	6J, 6 ½ J , 7J, 7 ½J	242	766	228	2285	115 112	S T	1390 2520	1580 2880	1750 3200	1930 3520	2120 3900	2260 4120	2430 4480	
LT 245/70 R 17	LRE	119/116	6 ½J, 7J, 7 ½J , 8J	263	796	248	2369	119 116	S T	1570 2860	1780 3240	2000 3600	2180 3960	2360 4240	2540 4640	2720 5000	
LT 265/70 R 17	LRE	121/118	7J, 7 ½J, 8J , 8 ½J	288	826	272	2454	121 118	S T	1760 3200	2000 3640	2240 4120	2440 4440	2640 4860	2780 5040	2900 5280	
LT 285/70 R 17	LRE	121/118	7 ½J, 8J, 8 ½J , 9J	310	854	292	2539	121 118	S T	1960 3560	2220 4040	2500 4600	2700 4920	2900 5280			
LT 295/70 R 17	LRE	121/118	7 ½ J, 8J, 8 ½J , 9J, 9 ½ J, 10 J	317	868	299	2582	121 118	S T	2060 3740	2340 4240	2640 4860	2780 5040	2900 5280			
LT 315/70 R 17	LRE	121/118	8J, 8 ½J, 9J, 9 ½ J, 10 J, 10 ½ J, 11 J	342	898	323	2648	121 118	S T	2300 4240	2580 4680	2900 5280					
LT 255/65 R 17	LRD	114/110	7J, 7 ½J , 8J, 8 ½J, 9J	276	784	260	2333	114 110	S T	1550 2820	1770 3220	1950 3500	2160 3940	2360 4240			
LT 265/65 R 17	LRE	120/117	7 ½J, 8J , 8 ½J, 9J, 9 ½J	288	796	272	2369	120 117	S T	1640 2980	1860 3380	2060 3700	2280 4160	2500 4600	2660 4840	2800 5140	
LT 285/65 R 17	LRE	121/118	8J, 8 ½J , 9J, 9 ½J, 10J	310	824	292	2448	121 118	S T	1850 3360	2080 3780	2300 4240	2540 4640	2800 5140	2860 5200	2900 5280	

***) Load Range, standardized according to TRA (Tire and Rim Association, USA). Classifies the max. load capacity of a tyre, corresponding PR. LR B equals 4 PR, LR C - 6 PR, LR D - 8 PR, LR E - 10 PR.

Tyre			Tyre dimensions				Rolling circumference	Load Index	Wheel position ⁹⁾	Load capacity (kg) per axle at a tyre pressure (bar)									
Size	Load Range	Load Index	Max. standard value in operation ²⁾		New tire on measuring rim	LI				2.5	3.0	3.5	4.0	4.5	5.0	5.5			
	LR ^{**)}	LI	Permitted rims ¹⁾ (measuring rim bold)	Width (mm)	Outer-Ø (mm)	Width (mm)													
LT sizes																			
18 inch																			
LT 275/70 R 18	LRE	125/122	7J, 7 ½J, 8J , 8 ½J	296	865	279	2572	125 122	S T	1920 3500	2180 3960	2430 4480	2680 4880	2900 5280	3120 5680	3300 6000			
LT 265/65 R 18	LRD	117/114	7 ½J, 8J , 8 ½J, 9J, 9 ½J	288	821	272	****	117 114	S T	1700 3100	1930 3520	2180 4000	2360 4280	2570 4720					
LT 265/60 R 18	LRE	119/116	7 ½J, 8J , 8 ½J, 9J, 9 ½J	288	793	272	2366	119 116	S T	1600 2920	1790 3260	2000 3600	2200 4000	2360 4240	2560 4640	2720 5000			
LT 285/60 R 18	LRD	118/115	8J, 8 ½J , 9J, 9 ½J, 10J	310	819	292	2439	118	S	1750	1990	2240	2440	2640					
	LRE	122/119						115	T	3180	3620	4120	4440	4860					
								122	S	1750	1990	2240	2440	2640	2840	3000			
								119	T	3180	3620	4120	4440	4860	5160	5440			
20 inch																			
LT 305/55 R 20	LRE	121/118	8 ½ J, 9J, 9 ½J , 10J, 10 ½ J, 11 J	335	864	316	2576	121 118	S T	1900 3500	2160 3940	2430 4480	2640 4800	2900 5280					
LT flotation-sizes ***)																			
										1.7	2.1	2.5	2.8	3.1	3.5	3.8	4.1	4.5	
15 inch																			
30 x 9.50 R 15 LT	LRC	104	6 ½ J, 7J, 7 ½J , 8J, 8 ½J	260	771	240	2291	104	S	1120	1280	1420	1560	1680	1800				
31 x 10.50 R 15 LT	LRC	109	7J, 7 ½J, 8J, 8 ½J , 9J	289	797	268	2366	109	S	1270	1450	1600	1760	1910	2060				
33 x 10.50 R 15 LT	LRC	114	7J, 7 ½ J, 8J, 8 ½J , 9J	289	850	268	2521	114	S	1480	1680	1850	2050	2220	2360				
33 x 12.50 R 15 LT	LRC	108	8 ½ J, 9J, 9 ½J, 10J , 10 ½J, 11J	343	850	318	2521	108	S	1600	1810	2000							
35 x 12.50 R 15 LT	LRC	113	8 ½ J, 9J, 9 ½J, 10J , 10 ½J, 11J	343	903	318	2675	113	S	1850	2080	2300							
17 inch																			
33 x 12.50 R 17 LT	LRC	105	8 ½ J, 9J, 9 ½J, 10J , 10 ½J, 11J	343	848	318	2521	105	S	1460	1680	1850							
	LRD	114						114	S	1460	1680	1850	2050	2210	2360				
35 x 12.50 R 17 LT	LRE	121	8 ½ J, 9J, 9 ½J, 10J , 10 ½J, 11J	343	901	318	2675	121	S	1700	1960	2180	2380	2580	2720	2780	2840	2900	
37 x 12.50 R 17 LT	LRC	116	8 ½ J, 9J, 9 ½J, 10J , 10 ½J, 11J	343	954	318	2830	116	S	1950	2240	2500							
18 inch																			
33 x 12.50 R 18 LT	LRE	118	8 ½ J, 9J, 9 ½J, 10J , 10 ½J, 11J	343	847	318	2521	118	S	1420	1600	1800	1950	2110	2240	2400	2540	2640	
35 x 12.50 R 18 LT	LRD	118	8 ½ J, 9J, 9 ½J, 10J , 10 ½J, 11J	343	900	318	2675	118	S	1650	1880	2120	2300	2480	2640				
	LRE	123						123	S	1650	1880	2120	2300	2480	2640	2830	2990	3100	
20 inch																			
33 x 12.50 R 20 LT	LRE	114	8 ½ J, 9J, 9 ½J, 10J , 10 ½J, 11J	343	845	318	2521	114	S	1260	1430	1600	1740	1880	2000	2120	2230	2360	
35 x 12.50 R 20 LT	LRE	121	8 ½ J, 9J, 9 ½J, 10J , 10 ½J, 11J	343	898	318	2675	121	S	1500	1720	1900	2100	2260	2420	2580	2730	2900	

** Load Range, standardized according to TRA (Tire and Rim Association, USA). Classifies the max. load capacity of a tyre, corresponding PR. LR B equals 4 PR, LR C - 6 PR, LR D - 8 PR, LR E - 10 PR.

*** for explanation of size designations see page 9, graph at the bottom (centre)

CST 17

CST = Conti Spare Tyre



The space- and weight-saving spare tyre in radial design for temporary, limited use. Approved for speeds of up to 80 km/h / 50 mph *)

This tyre may only be used in an emergency on one wheel of the vehicle with the agreement of the vehicle manufacturer. The T in the tyre designation indicates temporary use under restricted conditions.

*) According to UN-Regulation 64 governing the use of special spare tyres, those with a higher speed rating may also only be used up to a maximum speed of 80 km/h / 50 mph.

Technical data Special spare tyres for temporary use

Size	Tyre		Permitted rims ¹⁾ (measuring rim bold)	Tyre dimensions Max. standard value in operation ²⁾		Radius stat. + / - 2 % (mm)	Rolling circumference ³⁾ + 1.5 % - 2.5 % (mm)
	Load Index LI	Load capacity ⁴⁾ kg		Width (mm)	Outer-Ø (mm)		
95 series							
T 115/95 R 17	95	690	3 J⁵⁾ 3 ½ J ⁵⁾ 4 J ⁵⁾	118 122 128	658	298	1996
90 series							
T 125/90 R 15	96	710	3 J ⁵⁾ 3 ½ J⁵⁾ 4 J ⁵⁾	126 131 136	617	275	1863
T 115/90 R 16	92	630	3 J⁵⁾ 3 ½ J ⁵⁾ 4 J ⁵⁾	118 123 128	622	281	1885
T 125/90 R 16	98	750	3 J ⁵⁾ 3 ½ J⁵⁾ 4 J ⁵⁾	126 131 136	642	288	1940
T 135/90 R 16	102	850	3 ½ J⁵⁾ 4 J ⁵⁾ 4 ½ J ⁵⁾	138 143 148	660	294	1996
T 145/90 R 16	106	950	3 ½ J 4 J 4 ½ J 5 J	146 151 156 161	678	301	2051

*) Load capacity at 4.2 bar up to max. 130 km/h. Application-specific speed limited to 80 km/h (50 mph) in accordance with UN regulation 64.

Size	Tyre		Permitted rims ¹⁾ (measuring rim bold)	Tyre dimensions Max. standard value in operation ²⁾		Radius stat. + / - 2 % (mm)	Rolling circumference ³⁾ + 1.5 % - 2.5 % (mm)
	Load Index LI	Load capacity ⁴⁾ kg		Width (mm)	Outer-Ø (mm)		
90 series							
T 135/90 R 17	104	900	3 ½ J⁵⁾ 4 J ⁵⁾ 4 ½ J ⁵⁾	138 143 148	686	307	2075
T 165/90 R 17	105	925	4 J ⁵⁾ 4 ½ J 5 J 5 ½ J	167 172 177 182	742	329	2241
T 155/90 R 18	113	1150	4 J ⁵⁾ 4 ½ J⁵⁾ 5 J ⁵⁾	158 163 168	749	333	2263
85 series							
T 125/85 R 16	99	775	3 J ⁵⁾ 3 ½ J⁵⁾ 4 J ⁵⁾	126 131 136	626	283	1897
T 145/85 R 18	103	875	3 ½ J ⁵⁾ 4 J⁵⁾ 4 ½ J 5 J ⁵⁾	146 151 156 161	713	321	2158
T 155/85 R 18	115	1215	4 J 4 ½ J 5 J	158 163 168	731	327	2213
80 series							
T 125/80 R 15	95	690	3 J ⁵⁾ 3 ½ J⁵⁾ 4 J ⁵⁾	126 131 136	589	266	1784
T 135/80 R 15	100	800	3 ½ J⁵⁾ 4 J ⁵⁾ 4 ½ J ⁵⁾	138 143 148	605	272	1833
T 125/80 R 16	97	730	3 J ⁵⁾ 3 ½ J⁵⁾ 4 J ⁵⁾	126 131 136	614	278	1860
T 125/80 R 17	99	775	3 J ⁵⁾ 3 ½ J⁵⁾ 4 J ⁵⁾	126 131 136	640	291	1940
T 135/80 R 17	102 103	850 875	3 ½ J⁵⁾ 4 J ⁵⁾ 4 ½ J ⁵⁾	138 143 148	656	297	1989
T 145/80 R 17	107	975	3 ½ J 4 J 4 ½ J 5 J	146 151 156 161	674	303	2038

*) Load capacity at 4.2 bar up to max. 130 km/h. Application-specific speed limited to 80 km/h (50 mph) in accordance with UN regulation 64.

Size	Tyre		Permitted rims ¹⁾ (measuring rim bold)	Tyre dimensions Max. standard value in operation ²⁾		Radius stat. + / - 2 % (mm)	Rolling circumference ³⁾ + 1.5 % - 2.5 % (mm)
	Load Index LI	Load capacity ^{*)} kg		Width (mm)	Outer-Ø (mm)		
80 series							
T 165/80 R 17	104	900	4 J	167			
			4 ½ J	172	706	315	2137
			5 J	177			
T 135/80 R 18	104	900	3 ½ J⁵⁾	138	681	310	2066
			4 J ⁵⁾	143			
			4 ½ J ⁵⁾	148			
T 145/80 R 18	99	775	3 ½ J	146			
			4 J	151	699	316	2115
			4 ½ J	156			
T 145/80 R 19	110	1060	5 J	161			
			3 ½ J	146			
			4 J	151	725	328	2195
T 155/80 R 19	114	1180	4 ½ J	156			
			4 ½ J	163	741	334	2244
			5 J	168			
T 175/80 R 19	122	1500	4 ½ J	179			
			5 J	184	775	346	2342
			5 ½ J	189			
T 185/75 R 20	116	1250	6 J	194			
			4 ½ J	186			
			5 J	191	798	358	2411
T 115/70 R 15	90	600	3 J ⁵⁾	118			
			3 ½ J⁵⁾	123	549	251	1667
			4 J ⁵⁾	128			
T 125/70 R 15	95	690	3 J ⁵⁾	126			
			3 ½ J⁵⁾	131	565	256	1710
			4 J ⁵⁾	136			
T 135/70 R 15	99	775	3 ½ J ⁵⁾	139			
			4 J⁵⁾	144	579	261	1753
			4 ½ J ⁵⁾	149			
T 115/70 R 16	92	630	3 J ⁵⁾	118			
			3 ½ J⁵⁾	123	574	264	1744
			4 J ⁵⁾	128			
T 125/70 R 16	96	710	3 J ⁵⁾	126			
			3 ½ J⁵⁾	131	590	269	1787
			4 J ⁵⁾	136			

*) Load capacity at 4.2 bar up to max. 130 km/h. Application-specific speed limited to 80 km/h (50 mph) in accordance with UN regulation 64.

Size	Tyre		Permitted rims ¹⁾ (measuring rim bold)	Tyre dimensions Max. standard value in operation ²⁾		Radius stat. + / - 2 % (mm)	Rolling circumference ³⁾ + 1.5 % - 2.5 % (mm)
	Load Index LI	Load capacity ^{*)} kg		Width (mm)	Outer-Ø (mm)		
70 series							
T 135/70 R 16	100	800	3 ½ J ⁵⁾	139			
			4 J⁵⁾	144	604	274	1830
			4 ½ J ⁵⁾	149			
T 125/70 R 17	98	750	3 J ⁵⁾	126			
			3 ½ J⁵⁾	131	616	282	1867
			4 J ⁵⁾	136			
T 145/70 R 17	107	975	3 ½ J ⁵⁾	146			
			4 J ⁵⁾	151			
			4 ½ J⁵⁾	156	644	292	1953
T 155/70 R 17	110	1060	5 J ⁵⁾	161			
			4 J ⁵⁾	158			
			4 ½ J⁵⁾	163	658	297	1996
T 125/70 R 18	99	775	3 J ⁵⁾	126			
			3 ½ J⁵⁾	131	641	294	1943
			4 J ⁵⁾	136			
T 125/70 R 19	100	800	3 J	126			
			3 ½ J	131	667	307	2023
			4 J	136			
T 155/70 R 19	113	1150	4 J ⁵⁾	158			
			4 ½ J⁵⁾	163	709	323	2152
			5 J ⁵⁾	168			
65 series							
T 145/65 R 20	105	925	4 J ⁵⁾	151			
			4 ½ J⁵⁾	156	704	328	2123
			5 J	161			
T 145/65 R 20	105	925	5 ½ J	166			
			4 J ⁵⁾	151			
			4 ½ J⁵⁾	156	688	319	2094
T 125/60 R 18	94	670	3 ½ J	131	613	285	1863
			4 J	136			
			4 ½ J	141			
T 155/60 R 18	107	975	4 ½ J⁵⁾	163	651	298	1974
			5 J ⁵⁾	168			
			5 ½ J ⁵⁾	173			
T 145/60 R 20	105	925	4 J	151			
			4 ½ J	156	688	319	2094
			5 J	161			
T 165/60 R 20	113	1150	4 ½ J	172	712	328	2167
			5 J	177			
			5 ½ J	182			
T 165/60 R 20	113	1150	6 J	187			
			5 J	177			
			5 ½ J	182			

*) Load capacity at 4.2 bar up to max. 130 km/h. Application-specific speed limited to 80 km/h (50 mph) in accordance with UN regulation 64.

The ContiMobilityKit for extended movability.

The ContiMobilityKit is a convenient repair kit, designed to seal punctures in the tyre tread caused by nails or similar objects with a diameter of up to 6 mm. The kit consists of a compact compressor and a separate sealant bottle and has a shelf life of up to 5 years.

In case of a puncture, an emergency roadside tyre change is not necessary and the journey can be continued for another 200 km (125 miles) at a maximum speed of 80 km/h (50 mph). It's not even necessary to remove and replace the valve core - after just a few steps you are ready to go again.

The ContiMobilityKit is only suitable for passenger car tyres with a mandatory maximum tyre pressure of 3 bar.

Easy-to-use repair kit for sealing and reinflating a punctured tyre

- › Ensuring an unaltered driving performance for another 200 km (125 miles) at a maximum speed of 80 km/h (50 mph)
- › Original equipment quality 'Engineered in Germany'

Product contents:

- › Compressor
- › Pressure-resistant tyre sealant bottle
- › User manual
- › Bag
- › Gloves



Technical specifications of compressor:

Amperage	Voltage	Maximum pressure
Max. 10 A according to DIN ISO 8820	12 V	700 kPa (7 bar, 102 psi)
Dimensions (mm)	Weight	Area of application
150 x 130 x 60	650 g	-30 °C up to +60 °C

Technical specifications of sealant bottle:

Sealant amount	Shelf life	Dimensions (mm)
450 ml	5 years	Ø 87 x 125
Weight	Application temperature	
585 g	- 30°C up to + 60°C	

Spare parts for the ContiMobilityKit: the tyre sealant.

The tyre sealant is pumped by the Continental compressor into the tyre, enabling the onward journey to the nearest garage or tyre service (max. 80 km/h / 50 mph and max. 200 km / 125 miles). It seals car tyre punctures caused by nails or similar objects with a diameter of up to 6 mm.

- › Extended shelf life of up to five years
- › No need to remove and replace valve core

Product contents

- › Pressure-resistant 450 ml tyre sealant bottle

Technical specifications of sealant bottle:

Sealant amount	Shelf life	Dimensions (mm)
450 ml	5 years	Ø 87 x 125
Weight	Application temperature	
585 g	- 30°C up to + 60°C	



Spare parts for the ContiMobilityKit: the exchange hose.

After usage of the ContiMobilityKit, the hose needs to be replaced due to residue of sealant in the hose.

Produktumfang:

- › 50 cm hose including bottle connection for the ContiMobilityKit sealant bottle
- › Exchange manual
- › Plastic gloves
- › Speed warning label
- › Small plastic bag with screws

Technical specifications of exchange hose:

Hose length
50 cm



Suitable for many passenger car tyres. For a detailed list of tyre sizes see www.continental-mobility.com

Transporter- and Van tyres

ContiVanContact™ 100

For transporters and vans



- > High level of efficiency thanks to higher mileage
- > Improved durability on all roads and thus longer service life
- > High safety reserves for heavy loads

Tyre dimensions*

Tyre width in mm	165-285
Rim size in inches	14-17
Speed Symbol	Q-V
Tyre cross-section	series 55-80
Load Index	89-131

ContiVanContact™ 200

For transporters and vans



- > Safe journey thanks to shorter braking distances on wet roads
- > Considerably reduced rolling resistance for lower fuel consumption and greater efficiency
- > Safe handling in all situations, even under heavy loads

Tyre dimensions*

Tyre width in mm	185-235
Rim size in inches	15-17
Speed Symbol	R-V
Tyre cross-section	series 55-75
Load Index	95-121

VanContact™ Eco

For transporters and vans



- > Maximum fuel efficiency
- > Enhanced mileage
- > Noise- and comfort-optimised performance

Tyre dimensions*

Tyre width in mm	185-255
Rim size in inches	15-19
Speed Symbol	R-H
Tyre cross-section	series 50-75
Load Index	100-116

Vanco™ 2

For transporters and vans



- > Perceptible car-orientated handling
- > Excellent wet braking performance
- > Outstanding protection against aquaplaning

Tyre dimensions*

Tyre width in mm	175-235
Rim size in inches	14-17
Speed Symbol	P-T
Tyre cross-section	series 60-80
Load Index	100-121

Transporter- and Van tyres

Vanco™ Contact 2

For transporters and vans

- › Outstanding handling
- › Precise braking reaction and reduced stopping distance
- › Excellent protection against aquaplaning

Tyre dimensions*

Tyre width in mm	165-225
Rim size in inches	13-16
Speed Symbol	R-H
Tyre cross-section	series 60-70
Load Index	88-105



Vanco™ Eco

For transporters and vans

- › Cost-effective due to optimised rolling resistance
- › Short braking distances, even on wet surfaces
- › Perceptible car-like handling

Tyre dimensions*

Tyre width in mm	195 / 225
Rim size in inches	16
Speed Symbol	R / T
Tyre cross-section	series 60/75
Load Index	107 / 111



VanContact™ Camper

Allseason tyre for campers and mobile homes

- › A robust construction boosts safety during temporarily increased loads according to CP standards
- › Excellent handling and braking on dry roads
- › High braking performance on wet, muddy and snowy roads



Tyre dimensions*

Tyre width in mm	225-255
Rim size in inches	16 / 18
Speed Symbol	R
Tyre cross-section	series 55-75
Load Index	115-120



VanContact™ Winter

For vans, transporters and mobile homes

- › Shorter braking distances and improved traction on snow
- › High aquaplaning safety and shorter braking distances on wet roads
- › Improved rolling resistance



Tyre dimensions*

Tyre width in mm	165-285
Rim size in inches	14-17
Speed Symbol	Q-H
Tyre cross-section	series 55-80
Load Index	89-131



Size	Tyre		Rim ⁷⁾ (measuring rim bold)	TL valve (tube and valve)*)	Tyre dimensions						Radius stat. +/- 2 % (mm)	Rolling circumference + 1.5 % - 2.5 % (mm)	PR	Load Index LI	Wheel position ⁸⁾	Load capacity (kg) per axle at a tyre pressure (bar)														Speed Symbol and reference speed (km/h)				
	PR	Service description ⁶⁾			Max. standard value in operation ⁹⁾				new							Width	Outer- Ø	stat. +/- 2 % (mm)	Rolling circumference + 1.5 % - 2.5 % (mm)															
					Stand- ard	Spe- cial	Stand- ard	Spe- cial	Width	Outer- Ø										3.0	3.25	3.5	3.75	4.0	4.25	4.5	4.75	5.0	5.25		5.5	5.75	6.0	
13 inch																																		
165 R 13 C	6	91/89 R	4 J	43 GS 11.5	167	175	604	609	162	596	273	1806		6	91	S	1030	1095	1165	1230								R 170						
			4 ½ J		172	180		604	609						167	596	91	T	1940	2070	2195	2320												
165/70 R 13 C	6	88/86 R	4 ½ J ⁵⁾	43 GS 11.5	172		572	576	165	170	562	258	1703	6	88	S	935	1000	1060	1120								R 170						
			5 J		177			572	576						165	562	88	T	1775	1890	2005	2120												
14 inch																																		
175 R 14 C	8	99/98 P	4 ½ J	43 GS 11.5	178	187	642	648	173	634	293	1921		8	99	S	1120	1195	1270	1340	1410	1480	1550					P 150						
		99/98 Q	5 J		183	192		642	648						178	634	99	T	2170	2310	2450	2590	2730	2865	3000					Q 160				
			5 ½ J		188	197									183																			
185 R 14 C	8	102/100 Q	5 J	43 GS 11.5	189	198	659	665	183	650	299	1970		8	102	S	1230	1310	1390	1470	1545	1625	1700					Q 160						
		102/100 R	5 ½ J		194	203		659	665						188	650	102	T	2315	2465	2620	2765	2915	3060	3200					R 170				
195 R 14 C	8	106/104 Q	5 J	43 GS 11.5	199	209	675	682	193	666	306	2018		8	106	S	1375	1465	1555	1645	1730	1815	1900					Q 160						
		106/104 R	5 ½ J		204	214		675	682						198	666	106	T	2605	2775	2945	3110	3275	3440	3600					R 170				
205 R 14 C	8	109/107 P	5 ½ J	43 GS 11.5	209	220	696	703	203	686	312	2079		8	109	S	1490	1590	1685	1780	1875	1970	2060					P 150						
			6 J		214	225		696	703						208	686	109	T	2820	3005	3190	3370	3550	3725	3900									
215 R 14 C	8	112/110 P	5 ½ J	(43 GS 11.5)	220	230	710	717	213	700	319	2121		8	112	S	1620	1725	1830	1935	2040	2140	2240					P 150						
			6 J		225	235		710	717						218	700	112	T	3065	3270	3470	3665	3860	4050	4240									
165/75 R 14 C	8	97/95 R	4 J	TR 600 XHP, TR 602 HP	167		614	618	160	604	277	1830		8	97	S	1010	1080	1145	1210	1270	1335	1400	1460				R 170						
			4 ½ J		172			614	618						165	604	97	T	1910	2035	2160	2285	2405	2525	2645	2760								
185/75 R 14 C	8	102/100 Q	5 J	TR 600 XHP, TR 602 HP	191		646	–	184	634	289	1921		8	102	S	1175	1255	1330	1405	1480	1555	1630	1700				Q 160						
			5 ½ J		196			646	–						189	634	102	T	2215	2360	2505	2650	2790	2930	3065	3200								
195/75 R 14 C	8	106/104 Q	5 J	TR 600 XHP, TR 602 HP	199		666	–	191	648	295	1963		8	106	S	1315	1405	1490	1575	1655	1740	1820	1900				Q 160						
			5 ½ J		204			666	–						196	648	106	T	2495	2655	2820	2980	3140	3295	3450	3600								
165/70 R 14 C	6	89/87 R	4 ½ J	43 GS 11.5	172		598	602	165	170	588	270	1782	6	89	S	970	1035	1100	1160							R 170							
			5 J		177			598	602						165	170	89	T	1825	1945	2065	2180												
175/70 R 14 C	6	95/93 T	4 ½ J	43 GS 11.5	179		612	616	172	602	276	1824		6	95	S	1150	1230	1305	1380							T 190							
			5 J		184			612	616						177	602	95	T	2175	2315	2460	2600												
175/70 R 14 C	6	95/93 T	5 ½ J	43 GS 11.5	189		612	616	182	602	276	1824		6	93	T	2175	2315	2460	2600														

* 43 GS 11.5 are snap-in valves approved for up to 4.5 bar.

38 G 11.5 is a valve for the hose.

Standard rubber valves are only approved for up to 4.5 bar in service.

TR 600 XHP and TR 602 HP (ETRTO V3.23.1+2) are reinforced snap-in valves approved for up to 5.5 bar.

40 MS (ETRTO V2.04.1, V2.05.1) are metal valves approved for pressures up to 6 bar and higher.

Size	Tyre		Rim ⁷⁾ (measuring rim bold)	TL valve (tube and valve)* ¹⁾	Tyre dimensions						Radius stat. +/- 2% (mm)	Rolling circumference + 1.5% - 2.5% (mm)	PR	Load Index LI	Wheel position ⁹⁾	Load capacity (kg) per axle at a tyre pressure (bar)														Speed Symbol and reference speed (km/h)
	PR	Service description ⁶⁾			Max. standard value in operation ⁸⁾				new							Load capacity (kg) per axle at a tyre pressure (bar)														
					Stand- ard	Spe- cial	Stand- ard	Spe- cial	Width	Outer- Ø						3.0	3.25	3.5	3.75	4.0	4.25	4.5	4.75	5.0	5.25	5.5	5.75	6.0		
15 inch																														
185/65 R 15 C	6	97/95 T	5 J	43 GS 11.5 (1540, 38 G 11.5)	192	631	635	184	621	287	1882	6	97	S	1220	1300	1380	1460										T 190		
			5 ½ J 6 J		197 202			189 194							2310 2460	2610 2760														
205/65 R 15 C	6	102/100 R	5 ½ J	43 GS 11.5	212	657	663	204	647	297	1960	6	102	S	1420	1515	1605	1700										R 170 T 190		
		102/100 T	6 J 6 ½ J		217 222			209 214							2675 2855	3030 3200														
215/65 R 15 C	6	104/102 R	6 J	43 GS 11.5	225	673	677	216	661	302	2003	6	104	S	1505	1605	1700	1800										R 170 T 190		
		104/102 T	6 ½ J 7 J		230 235			221 226							2840 3030	3215 3400														
185/60 R 15 C	6	94/92 T	5 ½ J 6 J	43 GS 11.5	197 202	611	617	189 194	603	279	1827	6	94 92	S T	1120 2110	1195 2245	1270 2385	1340 2520										T 190		
185/55 R 15 C	6	90/88 T	5 ½ J 6 J	43 GS 11.5	197 202	593	598	189 194	585	272	1773	6	90 88	S T	1005 1875	1070 2000	1135 2120	1200 2240										T 190		
16 inch																														
235/85 R 16 C	8	114/111 Q	6 J	43 GS 11.5	239	822	830	230	806	363	2442	8	114	S	1635	1740	1850	1955	2055	2160	2260	2360						Q 160 S 180		
		120/116 Q	6 ½ J		244			235							3020	3220	3415	3610	3800	3990	4175	4360								
		120/116 S	7 J 7 ½ J		249 254			240 245							2970	3170	3360	3550	3740	3925	4110	4290	4470	4650	4825	5000				
205 R 16 C	8	110/108 T	5 ½ J 6 J 6 ½ J	43 GS 11.5	211 216 221	750	756	203 208 213	736	338	2230	8	110 108	S T	1535 2890	1635 3085	1735 3270	1830 3455	1930 3640	2025 3820	2120 4000							T 190		
175/75 R 16 C	8	101/99 R	4 ½ J 5 J 5 ½ J	TR 600 XHP, TR 602 HP	179 184 189	678	684	172 177 182	668	308	2024	8	101 99	S T	1140 2145	1215 2290	1290 2430	1360 2565	1435 2700	1505 2835	1575 2970	1650 3100						R 170		
185/75 R 16 C	8	104/102 R	5 J 5 ½ J 6 J	TR 600 XHP, TR 602 HP	191 196 201	696	700	184 189 194	684	314	2073	8	104 102	S T	1245 2355	1330 2510	1410 2665	1490 2815	1570 2965	1645 3110	1725 3255	1800 3400						R 170		
195/75 R 16 C	8	107/105 R	5 J	TR 600 XHP, TR 602 HP	199	710	716	191	698	320	2115	8	107	S	1350	1440	1525	1615	1700	1785	1865	1950						R 170 T 190		
		107/105 T	5 ½ J		204			196							2560	2730	2900	3060	3225	3385	3545	3700								
	10	110/108 R	6 J		209		201	209				10	110 108	S T	1355 2555	1445 2725	1535 2890	1620 3055	1705 3220	1790 3380	1875 3535	1955 3690	2040 3845	2120 4000						
195/75 R 16 CP	8	107 R		TR 600 XHP, TR 602 HP, 40 MS								8	107 107	FA S RA S RA T	1350 1200 2500	1440 1280 2665	1525 1360 2830	1615 1435 2990	1700 1510 3145	1785 1585 3300	1865 1660 3455	1950 1735 3610	1805	1880	1950					
205/75 R 16 C	8	110/108 R	5 ½ J	TR 600 XHP, TR 602 HP	211	726	732	203	714	326	2163	8	110	S	1470	1565	1660	1755	1850	1940	2030	2120						R 170		
		113/111 R	6 J 6 ½ J		216 221			208 213							2770	2955	3135	3310	3485	3660	3830	4000								
	10											10	113 111	S T	1470 2785	1565 2970	1665 3150	1755 3330	1850 3510	1940 3680	2035 3855	2125 4025	2210 4195	2300 4360						
215/75 R 16 C	8	113/111 R	5 ½ J	TR 600 XHP, TR 602 HP	220	740	748	211	728	332	2206	8	113	S	1590	1700	1800	1905	2005	2105	2205	2300						N 140 R 170		
		116/114 N	6 J		225			216							3020	3220	3415	3610	3800	3990	4175	4360								
	10	116/114 R	6 ½ J	TR 600 XHP, TR 602 HP, 40 MS	230			221					10	116	S	1600	1705	1805	1910	2010	2110	2210	2310	2405	2500					
		121/119 R	7 J		235	226	3015	3215	3410	3605	3795	3985	4170	4355	4540	4720														
														10	116 116 114	FA S RA S RA T	1600 1600 3015	1705 1705 3215	1805 1805 3410	1910 1910 3605	2010 2010 3795	2110 2110 3985	2210 2310 4170	2310 2405 4355	2405 2500 4540	2500 2500 4720	2500 2500 4910	2500 2500 5100		
	10											10	121 119	S T	1725 3235	1835 3445	1950 3655	2060 3865	2170 4070	2275 4270	2385 4470	2490 4670	2595 4865	2695 5060	2800 5250	2900 5440				

Size	Tyre		Rim ⁷⁾ (measuring rim bold)	TL valve (tube and valve)* ¹⁾	Tyre dimensions						Radius stat. +/- 2 % (mm)	Rolling circumference + 1.5 % - 2.5 % (mm)	PR	Load Index LI	Wheel position ⁹⁾	Load capacity (kg) per axle at a tyre pressure (bar)														Speed Symbol and reference speed (km/h)
	PR	Service description ⁶⁾			Max. standard value in operation ⁸⁾				new							Load capacity (kg) per axle at a tyre pressure (bar)														
					Width Stand- ard	Special	Outer-Ø Stand- ard	Special	Width	Outer- Ø						3.0	3.25	3.5	3.75	4.0	4.25	4.5	4.75	5.0	5.25	5.5	5.75	6.0		
16 inch																														
225/60 R 16 C	6	101/99 H	6 ½ J	43 GS 11.5	237	686	-	228	676	311	2048	6	101	S	1550	1650	1750	1850	1900	1995	2090	2180						T 190 H 210		
		105/103 H			7 J			242					233		2900	3100		1750											1850	
		105/103 H (101 H)			7 ½ J			247					238		1550	1650		3310											3500	
	8	111/109 T (105 H)	9 J	40 MS	309	732	738	297	720	329	2182	8	111	S	1510	1610	1705	1805	1900	1995	2090	2180								
10	126 N	8 ½ J			314	732	738	302	720	329	2182	10	126	FA S	2020	2155	2285	2415	2545	2670	2795	2920	3040	3160	3280	3400	N 140			
					9 ½ J			319							307	1550	1650	1750	1850											
17 inch																														
205/70 R 17 C	10	115/113 R	5 ½ J 6 J 6 ½ J	TR 600 XHP, TR 602 HP 40 MS	212 217 222	732	738	204 209 214	720	331	2182	10	115 113	S T	1555 2940	1655 3135	1755 3325	1855 3515	1955 3700	2050 3885	2150 4065	2245 4245	2335 4425	2430 4600			R 170			
245/70 R 17 C	8	121/119 Q	6 ½ J 7 J 7 ½ J	TR 600 XHP, TR 602 HP, 40 MS	253 258 263	790	796	243 248 253	776	354	2351	8	121 119	S T	2010 3765	2140 4015	2270 4260	2400 4505	2525 4740	2655 4975	2775 5210	2900 5440					Q 160			
185/60 R 17 C	6	96/94 R	5 ½ J 6 J	43 GS 11.5	197 202	662	668	189 194	654	305	1982	6	96 94	S T	1190 2240	1265 2390	1345 2535	1420 2680									R 170			
215/60 R 17 C	6	104/102 H	6 J	43 GS 11.5	225	700	706	216	690	319	2091	6	104	S	1505	1605	1705	1800	1795	1885	1975	2060					R 170 T 190 H 210			
		109/107 R			6 ½ J			230					221		2845	3030	3215	3400												
	8	109/107 T	7 J	43 GS 11.5	235	700	706	226	690	319	2091	8	109	S	1425	1520	1615	1705	1795	1885	1975	2060								
		109/107 T (104 H)			7 J			235					226		2700	2880	3055	3230	3400	3570	3735	3900								
235/60 R 17 C	8	114/112 R	6 ½ J	TR 600 XHP, TR 602 HP, 40 MS	245	726	730	235	714	329	2163	8	114	S	1635	1740	1850	1955	2055	2160	2260	2360					R 170			
		117/115 R			7 J			250					240		1550	1655	1755	1855	1950	2050	2145	2240	2470	2570						
225/55 R 17 C	6	104/102 H	6 ½ J	43 GS 11.5	237	690	-	228	680	315	2060	6	104	S	1505	1605	1705	1800	1795	1885	1975	2060					T 190 H 210			
		109/107 T (104 T)			7 J			242					233		2845	3030	3215	3400												
		109/107 H (104 H)			7 ½ J			247					238		1425	1520	1615	1705										1795	1885	1975
255/55 R 17 C	10	118/116 R	7 ½ J 8 J 8 ½ J	TR 600 XHP, TR 602 HP, 40 MS	271	724	728	260	712	328	2157	10	118	S	1685	1800	1910	2015	2125	2230	2335	2435	2540	2640			R 170			
					276			265					3195		3405	3615	3820	4020	4220	4420	4615	4810	5000							
					281			270					2700		2880	3055	3230	3400	3570	3735	3900									
315/55 R 17 C	10	131Q	9 ½ J 10 J	TR 600 XHP, TR 602 HP, 40 MS	299 340	790	798	323 328	776	354	2351	10	132	E	2375	2535	2690	2840	2990	3140	3290	3435	3575	3720	3860	4000	Q 160			
18 inch																														
255/55 R 18 C	8	116/114 T	7 ½ J 8 J 8 ½ J	43 GS 11.5	271	749	753	260	737	341	2233	8	116	S	1730	1845	1955	2065	2175	2285	2390	2500					R 170 T 190			
					276			265					3265		3480	3695	3905	4110	4315	4520	4720									
255/55 R 18 CP	10	120 R	8 ½ J	TR 600 XHP, TR 602 HP, 40 MS	281	749	753	270	737	341	2233	10	120	FA S RA S RA T	1790	1910	2025	2140	2255	2365	2475	2585	2695	2800	2610	2705	2800			
1.85x120	120	1610			1715			1820					1920		2025	2125	2225	2325	2420	2515	2610	2705	2800							

Increased load capacity of tyres on caravans and lightweight trailers (only applies to trailers with a max. speed of 100 km/h or 62 mph entered in the car registration documents).

Tyre size	LI	Max. Load capacity kg	Inflation pressure (bar)
Passenger Car Tyres			
82/80 series			
175 R 13	86	585	2,6
125/80 R 13	65	320	2,6
135/80 R 13	70	370	2,6
145/80 R 13	75	425	2,6
155/80 R 13	79	480	2,6
155/80 R 13 Rf.	83	535	3,1
165/80 R 13	83	535	2,6
165/80 R 13 Rf.	87	600	3,1
145/80 R 14	76	440	2,6
165/80 R 14	85	565	2,6
175/80 R 14	88	615	2,6
185/80 R 14	91	675	2,6
165/80 R 15	87	600	2,6
195/80 R 15	96	780	2,6
215/80 R 15	102	935	2,6
205/80 R 16 XL	104	990	3,0
75 series			
205/75 R 15	97	805	2,7
215/75 R 15	100	880	2,7
225/75 R 15	102	935	2,7
P 235/75 R 15	105	1020	2,7
235/75 R 15 XL	109	1135	3,1
265/75 R 15	112	1230	2,7
195/75 R 16 Rf.	100	880	3,1
215/75 R 16 XL	107	1070	3,1
225/75 R 16	104	990	2,7
225/75 R 16 XL	108	1100	3,1
P 235/75 R 16	106	1045	2,7
235/75 R 16	108	1100	2,7
235/75 R 16 XL	112	1230	3,1
245/75 R 16	111	1200	2,7
265/75 R 16	116	1375	2,7
235/75 R 17	109	1135	2,7
70 series			
135/70 R 13	68	345	2,7
145/70 R 13	71	380	2,7

Conditions of use:

An increase of 10 % for passenger tyres resp. 5 % for C van tyres over the load capacity, as quoted in these tables, is permitted when tyres are fitted to caravans

Increased load capacity of tyres on caravans and lightweight trailers (only applies to trailers with a max. speed of 100 km/h or 62 mph entered in the car registration documents).

Tyre size	LI	Max. Load capacity kg	Inflation pressure (bar)
Passenger Car Tyres			
70 series			
155/70 R 13	75	425	2,7
165/70 R 13	79	480	2,7
165/70 R 13 XL / Rf.	83	535	3,1
175/70 R 13	82	525	2,7
175/70 R 13 XL	86	585	3,1
185/70 R 13	86	585	2,7
155/70 R 14	77	455	2,7
165/70 R 14	81	510	2,7
165/70 R 14 XL / Rf.	85	565	3,1
175/70 R 14	84	550	2,7
175/70 R 14 XL	88	615	3,1
185/70 R 14	88	615	2,7
185/70 R 14 XL	92	695	3,1
195/70 R 14	91	675	2,7
205/70 R 14	95	760	2,7
205/70 R 14 XL	98	825	3,1
135/70 R 15	70	370	2,7
155/70 R 15	78	470	2,7
195/70 R 15 Rf.	97	805	3,1
205/70 R 15	96	780	2,7
205/70 R 15 XL	100	880	3,1
215/70 R 15	98	825	2,7
225/70 R 15	100	880	2,7
235/70 R 15	103	960	2,7
255/70 R 15	108	1100	2,7
265/70 R 15	112	1230	2,7
195/70 R 16	94	735	2,7
205/70 R 16	97	805	2,7
P 215/70 R 16	99	855	2,7
215/70 R 16	100	880	2,7
215/70 R 16 XL	104	990	3,1
225/70 R 16	102	935	2,7
	103	965	2,7
225/70 R 16 XL	107	1070	3,1
P 235/70 R 16	104	990	2,7
235/70 R 16	105	1020	2,7

and light trailers with a maximum operating speed up to 100 km/h (62 mph). The basic inflation pressure should be increased by 0.2 bar for passenger tyres and by +6 % for C van tyres, as quoted in these tables.

Increased load capacity of tyres on caravans and lightweight trailers (only applies to trailers with a max. speed of 100 km/h or 62 mph entered in the car registration documents).

Tyre size	LI	Max. Load capacity kg	Inflation pressure (bar)
Passenger Car Tyres			
70 series			
245/70 R 16	107	1070	2,7
245/70 R 16 XL	111	1200	3,1
255/70 R 16	111	1200	2,7
255/70 R 16 XL	115	1335	3,1
265/70 R 16	112	1230	2,7
275/70 R 16	114	1300	2,7
225/70 R 17 XL	108	1100	3,1
235/70 R 17 XL	109	1135	3,1
	111	1200	3,1
P 245/70 R 17	108	1100	2,7
245/70 R 17	110	1165	2,7
245/70 R 17 XL	114	1300	3,1
P 255/70 R 17	110	1165	2,7
255/70 R 17	112	1230	2,7
P 265/70 R 17	113	1265	2,7
265/70 R 17	115	1335	2,7
235/70 R 18	110	1165	2,7
265/70 R 18	116	1375	2,7
155/70 R 19	84	550	2,7
155/70 R 19 XL	88	615	3,1
65 series			
155/65 R 13	73	400	2,7
165/65 R 13	77	455	2,7
175/65 R 13	80	495	2,7
155/65 R 14	75	425	2,7
165/65 R 14	79	480	2,7
175/65 R 14	82	525	2,7
175/65 R 14 XL / Rf.	86	585	3,1
185/65 R 14	86	585	2,7
185/65 R 14 XL	90	660	3,1
195/65 R 14	89	640	2,7
145/65 R 15	72	390	2,7
155/65 R 15	77	455	2,7
165/65 R 15	81	510	2,7
175/65 R 15	84	550	2,7
175/65 R 15 XL	88	615	3,1
185/65 R 15	88	615	2,7
185/65 R 15 XL	92	695	3,1
195/65 R 15	91	675	2,7
195/65 R 15 XL / Rf.	95	760	3,1
205/65 R 15	94	735	2,7

Tyre size	LI	Max. Load capacity kg	Inflation pressure (bar)
Passenger Car Tyres			
65 series			
205/65 R 15 XL / Rf.	99	855	3,1
215/65 R 15	96	780	2,7
215/65 R 15 Rf.	100	880	3,1
195/65 R 16	92	695	2,7
205/65 R 16	95	760	2,7
215/65 R 16	98	825	2,7
215/65 R 16 XL	102	935	3,1
235/65 R 16	103	965	2,7
255/65 R 16	109	1135	2,7
205/65 R 17	96	780	2,7
215/65 R 17	98	825	2,7
	99	855	2,7
215/65 R 17 XL	103	965	3,1
225/65 R 17	102	935	2,7
225/65 R 17 XL	106	1045	3,1
235/65 R 17	103	965	2,7
	104	990	2,7
235/65 R 17 XL	108	1100	3,1
245/65 R 17	107	1070	2,7
245/65 R 17 XL	111	1200	3,1
255/65 R 17	110	1165	2,7
255/65 R 17 XL	114	1300	3,1
265/65 R 17	112	1230	2,7
265/65 R 17 XL	116	1375	3,1
275/65 R 17	115	1335	2,7
285/65 R 17	116	1375	2,7
235/65 R 18	106	1045	2,7
235/65 R 18 XL	110	1165	3,1
255/65 R 18	111	1200	2,7
265/65 R 18	114	1300	2,7
275/65 R 18	116	1375	2,7
235/65 R 19 XL	109	1135	3,1
255/65 R 19 XL	114	1300	3,1
60 series			
165/60 R 13	73	400	2,7
175/60 R 13	77	455	2,7
185/60 R 13	80	495	2,7
165/60 R 14	75	425	2,7
165/60 R 14 XL	79	480	3,1
175/60 R 14	79	480	2,7
185/60 R 14	82	525	2,7

Increased load capacity of tyres on caravans and lightweight trailers (only applies to trailers with a max. speed of 100 km/h or 62 mph entered in the car registration documents).

Tyre size	LI	Max. Load capacity kg	Inflation pressure (bar)
Passenger Car Tyres			
60 series			
185/60 R 14 XL	86	585	3,1
195/60 R 14	86	585	2,7
155/60 R 15	74	410	2,7
165/60 R 15	77	455	2,7
165/60 R 15 XL	81	510	3,1
175/60 R 15	81	510	2,7
185/60 R 15	84	550	2,7
185/60 R 15 XL	88	615	3,1
195/60 R 15	88	615	2,7
195/60 R 15 XL	92	695	3,1
205/60 R 15	91	675	2,7
205/60 R 15 XL / Rf.	95	760	3,1
215/60 R 15	95	760	2,7
215/60 R 15 XL	98	825	3,1
225/60 R 15	96	780	2,7
235/60 R 15	98	825	2,7
255/60 R 15	102	935	2,7
275/60 R 15	107	1070	2,7
185/60 R 16	86	585	2,7
195/60 R 16	89	640	2,7
195/60 R 16 XL	93	715	3,1
205/60 R 16	92	695	2,7
205/60 R 16 XL	96	780	3,1
215/60 R 16	95	760	2,7
215/60 R 16 XL / Rf.	99	855	3,1
225/60 R 16	98	825	2,7
225/60 R 16 XL / Rf.	102	935	3,1
235/60 R 16	100	880	2,7
235/60 R 16 XL / Rf.	104	990	3,1
205/60 R 17	93	715	2,7
205/60 R 17 XL	97	805	3,1
215/60 R 17	96	780	2,7
215/60 R 17 XL	100	880	3,1
225/60 R 17	99	855	2,7
225/60 R 17 XL	103	965	3,1
235/60 R 17	102	935	2,7
235/60 R 17 XL	106	1045	3,1
255/60 R 17	106	1045	2,7
275/60 R 17	110	1165	2,7
215/60 R 18 XL	98	825	3,1
P 225/60 R 18	99	855	2,7
Tyre size	LI	Max. Load capacity kg	Inflation pressure (bar)
Passenger Car Tyres			
60 series			
225/60 R 18	100	880	2,7
225/60 R 18 XL	104	990	3,1
235/60 R 18	103	965	2,7
235/60 R 18 XL	107	1070	3,1
P 245/60 R 18	104	990	2,7
245/60 R 18	105	1020	2,7
255/60 R 18	108	1100	2,7
255/60 R 18 XL	112	1230	3,1
265/60 R 18	110	1165	2,7
265/60 R 18 XL	114	1300	3,1
275/60 R 18	113	1265	2,7
285/60 R 18	116	1375	2,7
175/60 R 19	86	585	2,7
255/60 R 19	109	1135	2,7
255/60 R 19 XL	113	1265	3,1
155/60 R 20	80	495	2,7
175/60 R 20 XL+	97	805	3,1
235/60 R 20 XL	108	1100	3,1
245/60 R 20	107	1070	2,7
255/60 R 20 XL	113	1265	3,1
275/60 R 20	115	1335	2,7
275/60 R 20 XL	119	1495	3,1
55 series			
195/55 R 13	80	495	2,7
185/55 R 14	80	495	2,7
175/55 R 15	77	455	2,7
185/55 R 15	82	525	2,7
185/55 R 15 XL / Rf.	86	585	3,1
195/55 R 15	85	565	2,7
195/55 R 15 XL / Rf.	89	640	3,1
205/55 R 15	88	615	2,7
225/55 R 15	92	695	2,7
185/55 R 16	83	535	2,7
185/55 R 16 XL	87	600	3,1
195/55 R 16	87	600	2,7
195/55 R 16 XL	91	675	3,1
205/55 R 16	91	675	2,7
205/55 R 16 XL	94	735	3,1
215/55 R 16	93	715	2,7
215/55 R 16 Rf.	95	760	3,1
215/55 R 16 XL	97	805	3,1

Increased load capacity of tyres on caravans and lightweight trailers (only applies to trailers with a max. speed of 100 km/h or 62 mph entered in the car registration documents).

Tyre size	LI	Max. Load capacity kg	Inflation pressure (bar)
Passenger Car Tyres			
55 series			
225/55 R 16	95	760	2,7
225/55 R 16 XL	99	855	3,1
255/55 R 16	103	965	2,7
195/55 R 17	88	615	2,7
205/55 R 17	91	675	2,7
205/55 R 17 XL	95	760	3,1
215/55 R 17	94	735	2,7
215/55 R 17 XL	98	825	3,1
225/55 R 17	97	805	2,7
225/55 R 17 XL / Rf.	101	910	3,1
235/55 R 17	99	855	2,7
235/55 R 17 XL / Rf.	103	965	3,1
245/55 R 17	102	935	2,7
255/55 R 17	104	990	2,7
275/55 R 17	109	1135	2,7
205/55 R 18 XL	96	780	3,1
215/55 R 18	95	760	2,7
215/55 R 18 XL	99	855	3,1
225/55 R 18	98	825	2,7
225/55 R 18 XL	102	935	3,1
235/55 R 18	100	880	2,7
235/55 R 18 XL	104	990	3,1
245/55 R 18 XL	107	1070	3,1
255/55 R 18	105	1020	2,7
255/55 R 18 XL	109	1135	3,1
205/55 R 19 XL	97	805	3,1
225/55 R 19	99	855	2,7
225/55 R 19 XL	103	965	3,1
235/55 R 19	101	910	2,7
235/55 R 19 XL	105	1020	3,1
245/55 R 19	103	965	2,7
255/55 R 19	107	1070	2,7
255/55 R 19 XL	111	1200	3,1
265/55 R 19	109	1135	2,7
265/55 R 19 XL	113	1265	3,1
275/55 R 19	111	1200	2,7
175/55 R 20	85	565	2,7
195/55 R 20 XL	95	760	3,1
235/55 R 20	102	935	2,7
235/55 R 20 XL	105	1020	3,1
255/55 R 20	107	1070	2,7
Tyre size	LI	Max. Load capacity kg	Inflation pressure (bar)
Passenger Car Tyres			
55 series			
255/55 R 20 XL	110	1165	3,1
275/55 R 20 XL	117	1415	3,1
50 series			
175/50 R 13	72	390	2,7
185/50 R 14	77	455	2,7
165/50 R 15	72	390	2,7
195/50 R 15	82	525	2,7
195/50 R 15 XL	86	585	3,1
205/50 R 15	86	585	2,7
185/50 R 16	81	510	2,7
195/50 R 16	84	550	2,7
195/50 R 16 XL	88	615	3,1
205/50 R 16	87	600	2,7
225/50 R 16	92	695	2,7
	93	715	2,7
205/50 R 17	89	640	2,7
205/50 R 17 XL	93	715	3,1
215/50 R 17	91	675	2,7
215/50 R 17 XL	95	760	3,1
225/50 R 17	94	735	2,7
225/50 R 17 XL	98	825	3,1
235/50 R 17	96	780	2,7
235/50 R 17 XL	100	880	3,1
245/50 R 17	99	855	2,7
215/50 R 18	92	695	2,7
215/50 R 18 XL	96	780	3,1
225/50 R 18	95	760	2,7
225/50 R 18 XL	99	855	3,1
235/50 R 18	97	805	2,7
235/50 R 18 XL	101	910	3,1
245/50 R 18	100	880	2,7
245/50 R 18 XL	104	990	3,1
285/50 R 18	109	1135	2,7
205/50 R 19 XL	94	735	3,1
215/50 R 19 XL	93	715	3,1
225/50 R 19 XL	100	880	3,1
235/50 R 19	99	855	2,7
235/50 R 19 XL	103	965	3,1
245/50 R 19	101	910	2,7
245/50 R 19 XL	105	1020	3,1

Increased load capacity of tyres on caravans and lightweight trailers (only applies to trailers with a max. speed of 100 km/h or 62 mph entered in the car registration documents).

Tyre size	LI	Max. Load capacity kg	Inflation pressure (bar)
Passenger Car Tyres			
50 series			
255/50 R 19	103	965	2,7
255/50 R 19 XL	107	1070	3,1
265/50 R 19	106	1045	2,7
265/50 R 19 XL	110	1165	3,1
275/50 R 19 XL	112	1230	3,1
235/50 R 20	100	880	2,7
245/50 R 20	102	935	2,7
245/50 R 20 XL	105	1020	3,1
255/50 R 20	105	1020	2,7
255/50 R 20 XL	109	1135	3,1
265/50 R 20 XL	111	1200	3,1
275/50 R 20	109	1135	2,7
275/50 R 20 XL	113	1265	3,1
285/50 R 20	112	1230	2,7
285/50 R 20 XL	116	1375	3,1
295/50 R 20 XL	118	1450	3,1
305/50 R 20 XL	120	1540	3,1
255/50 R 21 XL	109	1135	3,1
275/50 R 21 XL	113	1265	3,1
45 series			
195/45 R 13	75	425	2,7
195/45 R 14	77	455	2,7
195/45 R 15	78	470	2,7
195/45 R 16	80	495	2,7
195/45 R 16 XL	84	550	3,1
205/45 R 16	83	535	2,7
205/45 R 16 XL	87	600	3,1
215/45 R 16	86	585	2,7
215/45 R 16 XL	90	660	3,1
225/45 R 16	89	640	2,7
245/45 R 16	94	735	2,7
195/45 R 17	81	510	2,7
205/45 R 17	84	550	2,7
205/45 R 17 XL	88	615	3,1
215/45 R 17	87	600	2,7
215/45 R 17 XL	91	675	3,1
225/45 R 17	91	675	2,7
225/45 R 17 XL / Rf.	94	735	3,1
235/45 R 17	94	735	2,7
235/45 R 17 XL	97	805	3,1
245/45 R 17	95	760	2,7

Tyre size	LI	Max. Load capacity kg	Inflation pressure (bar)
Passenger Car Tyres			
45 series			
245/45 R 17 XL / Rf.	99	855	3,1
255/45 R 17	98	825	2,7
255/45 R 17 XL	102	935	3,1
205/45 R 18 XL	90	660	3,1
215/45 R 18 XL	93	715	3,1
225/45 R 18	91	675	2,7
225/45 R 18 XL	95	760	3,1
235/45 R 18	94	735	2,7
235/45 R 18 XL	98	825	3,1
245/45 R 18	96	780	2,7
245/45 R 18 XL	100	880	3,1
255/45 R 18	99	855	2,7
255/45 R 18 XL	103	965	3,1
265/45 R 18	101	910	2,7
275/45 R 18	103	965	2,7
225/45 R 19	92	695	2,7
225/45 R 19 XL	96	780	3,1
235/45 R 19	95	760	2,7
235/45 R 19 XL	99	855	3,1
245/45 R 19	98	825	2,7
245/45 R 19 XL	102	935	3,1
255/45 R 19	100	880	2,7
255/45 R 19 XL	104	990	3,1
265/45 R 19 XL	105	1020	3,1
275/45 R 19 XL	108	1100	3,1
285/45 R 19	107	1070	2,7
285/45 R 19 XL	111	1200	3,1
295/45 R 19	109	1135	2,7
215/45 R 20 XL	95	760	3,1
235/45 R 20 XL	100	880	3,1
245/45 R 20	99	855	2,7
245/45 R 20 XL	103	965	3,1
255/45 R 20	101	910	2,7
255/45 R 20 XL	105	1020	3,1
265/45 R 20	104	990	2,7
265/45 R 20 XL	108	1100	3,1
275/45 R 20 XL	110	1165	3,1
285/45 R 20 XL	112	1230	3,1
295/45 R 20 XL	114	1300	3,1
245/45 R 21 XL	104	990	3,1
255/45 R 21 XL	105	1020	3,1

Increased load capacity of tyres on caravans and lightweight trailers (only applies to trailers with a max. speed of 100 km/h or 62 mph entered in the car registration documents).

Tyre size	LI	Max. Load capacity kg	Inflation pressure (bar)
Passenger Car Tyres			
45 series			
265/45 R 21 XL	108	1100	3,1
275/45 R 21	107	1070	2,7
275/45 R 21 XL	110	1165	3,1
285/45 R 21	109	1135	2,7
285/45 R 21 XL	113	1265	3,1
315/45 R 21	116	1375	2,7
255/45 R 22 XL	107	1070	3,1
275/45 R 22 XL	112	1230	3,1
285/45 R 22 XL	114	1300	3,1
305/45 R 22 XL	118	1450	3,1
40 series			
195/40 R 14	73	400	2,7
195/40 R 16 XL	80	495	3,1
215/40 R 16 XL	86	585	3,1
225/40 R 16	85	565	2,7
195/40 R 17 XL	81	510	3,1
205/40 R 17 XL	84	550	3,1
215/40 R 17	83	535	2,7
215/40 R 17 XL	87	600	3,1
235/40 R 17	90	660	2,7
245/40 R 17	91	675	2,7
245/40 R 17 XL	95	760	3,1
255/40 R 17	94	735	2,7
255/40 R 17 XL	98	825	3,1
205/40 R 18 XL	86	585	3,1
215/40 R 18	85	565	2,7
215/40 R 18 XL	89	640	3,1
225/40 R 18	88	615	2,7
225/40 R 18 XL	92	695	3,1
235/40 R 18	91	675	2,7
235/40 R 18 XL	95	760	3,1
245/40 R 18	93	715	2,7
245/40 R 18 XL	97	805	3,1
255/40 R 18	95	760	2,7
255/40 R 18 XL	99	855	3,1
265/40 R 18 XL	101	910	3,1
275/40 R 18	99	855	2,7
275/40 R 18 XL	103	965	3,1
225/40 R 19	89	640	2,7
225/40 R 19 XL	93	715	3,1
235/40 R 19	92	695	2,7

Tyre size	LI	Max. Load capacity kg	Inflation pressure (bar)
Passenger Car Tyres			
40 series			
235/40 R 19 XL	96	780	3,1
245/40 R 19	94	735	2,7
245/40 R 19 XL	98	825	3,1
255/40 R 19	96	780	2,7
255/40 R 19 XL	100	880	3,1
265/40 R 19	98	825	2,7
265/40 R 19 XL	102	935	3,1
275/40 R 19	101	910	2,7
275/40 R 19 XL	105	1020	3,1
285/40 R 19	103	965	2,7
285/40 R 19 XL	107	1075	3,1
295/40 R 19 XL	108	1100	3,1
225/40 R 20 XL	94	735	3,1
235/40 R 20 XL	96	780	3,1
245/40 R 20	95	760	2,7
245/40 R 20 XL	99	855	3,1
255/40 R 20	97	805	2,7
255/40 R 20 XL	101	910	3,1
265/40 R 20 XL	104	990	3,1
275/40 R 20 XL	106	1045	3,1
285/40 R 20	104	990	2,7
285/40 R 20 XL	108	1100	3,1
295/40 R 20 XL	110	1165	3,1
305/40 R 20 XL	112	1230	3,1
245/40 R 21 XL	100	880	3,1
255/40 R 21 XL	102	935	3,1
265/40 R 21	101	910	2,7
265/40 R 21 XL	105	1020	3,1
275/40 R 21 XL	107	1075	3,1
285/40 R 21 XL	109	1135	3,1
295/40 R 21 XL	111	1200	3,1
315/40 R 21	111	1200	2,7
315/40 R 21 XL	115	1335	3,1
325/40 R 21	113	1265	2,7
255/40 R 22 XL	103	965	3,1
265/40 R 22 XL	106	1045	3,1
275/40 R 22 XL	107	1070	3,1
275/40 R 22 XL	108	1100	3,1
285/40 R 22	106	1045	2,7
285/40 R 22 XL	110	1165	3,1
305/40 R 22 XL	114	1300	3,1

Increased load capacity of tyres on caravans and lightweight trailers (only applies to trailers with a max. speed of 100 km/h or 62 mph entered in the car registration documents).

Tyre size	LI	Max. Load capacity kg	Inflation pressure (bar)
Passenger Car Tyres			
40 series			
325/40 R 22	114	1300	2,7
285/40 R 23 XL	111	1200	3,1
305/40 R 23 XL	115	1335	3,1
285/40 R 24 XL	112	1230	3,1
305/40 R 24 XL	117	1415	3,1
35 series			
215/35 R 17 XL	83	535	3,1
245/35 R 17	87	600	2,7
215/35 R 18 XL	84	550	3,1
225/35 R 18 XL	87	600	3,1
245/35 R 18	88	615	2,7
245/35 R 18 XL	92	695	3,1
255/35 R 18	90	660	2,7
255/35 R 18 XL	94	735	3,1
265/35 R 18	93	715	2,7
265/35 R 18 XL	97	805	3,1
275/35 R 18	95	760	2,7
275/35 R 18 XL	99	855	3,1
285/35 R 18	97	805	2,7
285/35 R 18 XL	101	910	3,1
215/35 R 19 XL	85	565	3,1
225/35 R 19 XL	88	615	3,1
235/35 R 19	87	600	2,7
235/35 R 19 XL	91	675	3,1
245/35 R 19 XL	93	715	3,1
255/35 R 19	92	695	2,7
255/35 R 19 XL	96	780	3,1
265/35 R 19	94	735	2,7
265/35 R 19 XL	98	825	3,1
275/35 R 19 XL	100	880	3,1
285/35 R 19	99	855	2,7
285/35 R 19 XL	103	965	3,1
295/35 R 19	100	880	2,7
295/35 R 19 XL	104	990	3,1
225/35 R 20 XL	90	660	3,1
235/35 R 20	88	615	2,7
235/35 R 20 XL	92	695	3,1
245/35 R 20	91	675	2,7
245/35 R 20 XL	95	760	3,1
255/35 R 20 XL	97	805	3,1
265/35 R 20	95	760	2,7
30 series			
255/30 R 18 XL	90	660	3,1
285/30 R 18	93	715	2,7
295/30 R 18	94	735	2,7
295/30 R 18 XL	98	825	3,1
245/30 R 19 XL	89	640	3,1
255/30 R 19 XL	91	675	3,1
265/30 R 19 XL	93	715	3,1
275/30 R 19 XL	96	780	3,1
285/30 R 19 XL	98	825	3,1
295/30 R 19	96	780	2,7
295/30 R 19 XL	100	880	3,1

Increased load capacity of tyres on caravans and lightweight trailers (only applies to trailers with a max. speed of 100 km/h or 62 mph entered in the car registration documents).

Tyre size	LI	Max. Load capacity kg	Inflation pressure (bar)
Passenger Car Tyres			
30 series			
305/30 R 19 XL	102	935	3,1
325/30 R 19 XL	105	1020	3,1
225/30 R 20 XL	85	565	3,1
235/30 R 20 XL	88	615	3,1
245/30 R 20 XL	90	660	3,1
255/30 R 20 XL	92	695	3,1
265/30 R 20 XL	94	735	3,1
275/30 R 20 XL	97	805	3,1
285/30 R 20 XL	99	855	3,1
295/30 R 20 XL	101	910	3,1
305/30 R 20 XL	103	965	3,1
325/30 R 20 XL	106	1045	3,1
335/30 R 20 XL	108	1100	3,1
245/30 R 21 XL	91	675	3,1
255/30 R 21 XL	93	715	3,1
265/30 R 21 XL	96	780	3,1
275/30 R 21 XL	98	825	3,1
285/30 R 21 XL	100	880	3,1
295/30 R 21 XL	102	935	3,1
305/30 R 21	100	800	2,7
315/30 R 21 XL	105	1020	3,1
325/30 R 21 XL	108	1100	3,1
255/30 R 22 XL	95	760	3,1
265/30 R 22 XL	97	805	3,1
285/30 R 22 XL	101	910	3,1
295/30 R 22 XL	103	965	3,1
315/30 R 22 XL	107	1070	3,1
305/30 R 23 XL	105	1020	3,1
335/30 R 23 XL	111	1200	3,1
295/30 R 24 XL+	108	1100	3,1
335/30 R 24 XL	112	1230	3,1
25 series			
315/25 R 19 XL	98	825	3,1
285/25 R 20 XL	93	715	3,1
295/25 R 20 XL	95	760	3,1
305/25 R 20 XL	97	805	3,1
325/25 R 20 XL	101	910	3,1
275/25 R 21 XL	92	695	3,1
295/25 R 21 XL	96	780	3,1
305/25 R 21 XL	98	825	3,1
325/25 R 21 XL	102	935	3,1

Increased load capacity of tyres on caravans and lightweight trailers (only applies to trailers with a max. speed of 100 km/h or 62 mph entered in the car registration documents).

Tyre size	PR	LI	Max ^{**) Load capacity kg}	Inflation pressure (bar)
Commercial-C-tyres ^{*)}				
13 inch				
165 R 13 C	6	91	645	3,75
165/70 R 13 C	6	88	590	3,75
14 inch				
175 R 14 C	8	99	815	4,5
185 R 14 C	6	99	815	3,75
	8	102	895	4,5
195 R 14 C	8	106	1000	4,5
205 R 14 C	8	109	1080	4,5
215 R 14 C	8	112	1175	4,5
165/75 R 14 C	8	97	765	4,75
185/75 R 14 C	8	102	895	4,75
195/75 R 14 C	8	106	1000	4,75
165/70 R 14 C	6	89	610	3,75
175/70 R 14 C	6	95	725	3,75
195/70 R 14 C	8	101	865	4,75
175/65 R 14 C	6	90	630	3,75
15 inch				
185 R 15 C	8	103	920	4,5
195 R 15 C	8	106	1000	4,5
215/80 R 15 C	8	111	1145	4,75
245/75 R 15 C	6	109	1080	3,75
195/70 R 15 C	6	100	840	3,75
	8	104	945	4,5
205/70 R 15 C	8	106	1000	4,5
215/70 R 15 C	8	109	1080	4,5
225/70 R 15 C	6	109	1080	3,75
	8	112	1175	4,5
205/65 R 15 C	6	102	895	3,75
215/65 R 15 C	6	104	945	3,75
185/60 R 15 C	6	94	705	3,75
185/55 R 15 C	6	90	630	3,75
16 inch				
235/85 R 16 C	8	114	1240	4,75
	10	120	1470	5,75
205 R 16 C	8	110	1115	4,5
175/75 R 16 C	8	101	865	4,75
185/75 R 16 C	8	104	945	4,75

^{*)} 14, 15 and small 16 to 18 inch C tyres with treads like pass. car tyres for service on delivery vans.

For other C tyres, see Technical Databook for truck tyres.

^{**) also for C tyres: Load capacity per tyre (single fitment).}

The rim is the part of the wheel which supports the tyre.

1. Important elements of the rim

Rim flange = lateral support for the tyre bead

Flange distance = clear rim width

Bead seat = base on which the tyre bead is seated

Well = inner side of the rim

Diameter = specified diameter flange / bead seat

Hump = continuous raised section of the rim bead seat which enables a better fitting of tubeless tyre beads at **low pressure**^{*)}.

2. Types of rims

The well-base rim is virtually the only type of rim used on cars, caravans and other car trailers:

Well-base rims = one-piece rims, deepened well for easier tyre fitting, 5 "tapered bead seat, "x" in the wheel size designation.

Virtually only J and B versions of the well-base rim are used and these are explained here in more detail.

If rubber valves (snap-in type) are used on rims for higher speeds, these must be fitted with **valve supports** where necessary.

Also refer to the section "Fitting the tyre".

3. Wheel disc (nave)

The wheel disc is the linking element between the rim and the axle hub. Of all the measurements for wheel linking elements – centre bore and bore diameter, bolt hole type and **offset depth** – the latter is a particularly important factor for the free movement of the tyre in any wheel position.

(Offset depth = 0, when the rim centre and hub contact area of the wheel disc are in line).

4. Wheel strength

The wheel manufacturer must confirm that the wheel strength is adequate for each particular application.

5. Lateral and true running of the wheels (without tyres)

On cars which are virtually all able to considerably exceed 100 km/h (62 mph), it is particularly important that the wheels of the vehicle are **well-centred**.

There should be as little radial and lateral run-out as possible on both bead seat / flange sides of the rim, in order to achieve **good smooth running**.

The standard shows max. tolerances of 1.20 mm. This dimension is for the centre of the tyre seat area or the centre of the flange height. All measurements, particularly the **uniformity**, should be well within these tolerances.

^{*)} Safety shoulders (e. g. hump) are prescribed for tubeless radial car tyres. They should also be used for tubeless light truck C tyres with a 14 to 18 inch code for the rim diameter.

R₄ and R₅: between 4 and 10 mm
 R₅: not larger than 10 mm
 Valve Hole-Ø: 11.5 mm (11.3₋₀^{+0.4} centrally in the side of the rim well.
 16.0 mm (15.7 mm₋₀^{+0.4}) only with Ø-Code 15.

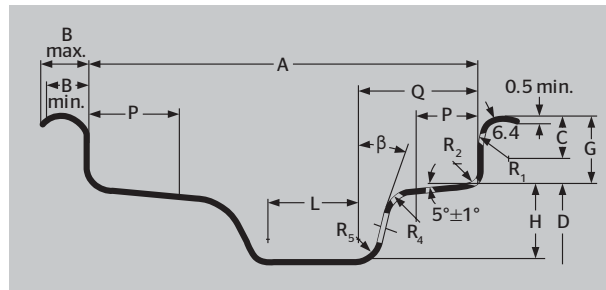

Rim Contour	Dimensions (mm)										
	A	B		G	P	H	L	Q	R ₁	R ₂	β
		Min.	Max. ¹⁾	± 0,6	Min.	Min. ²⁾	Min.	Max.	Min.	Max.	Min.
3.00 B	76				13		16	28			10°
3.50 B	89				15		19	34			
4.00 B	101.5										
4.50 B	114.5	10	13	14.1		15			7.5	4.5	13°
5.00 B	127				19.5		22	45			
5.50 B	139.5										
6.00 B	152.5										
3 J	76	± 1			13		16	28			10°
3 ½ J	89				15		19	34			
4 J	101.5										
4 ½ J	114.5										
5 J	127										
5 ½ J	139.5										
6 J	152.5										
6 ½ J	165										
7 J	178										
7 ½ J	190.5										
8 J	203					17.3			9.5	6.5	20°
8 ½ J	216				19.5		22	45			
9 J	228.5										
9 ½ J	241.5	± 1.5									
10 J	254										
10 ½ J	266.5										
11 J	279.5										
11 ½ J	292										
12 J	305										
12 ½ J	317.5										
13 J	330										

¹⁾ B max. values may be exceeded on rims for light commercial vehicles
²⁾ Minimum dimensions for well depth (H) and well angle are required for tyre mounting

Rim diameter													
Code (inch)	12	13	14	15	16	17	18	19	20	21	22	23	24
D (mm)	304.0	329.4	354.8	380.2	405.6	436.6	462.0	487.4	512.8	538.2	563.6	589.0	614.4

Special rim designs for passenger cars

In many countries safety rims must be used for tubeless radial tyres.

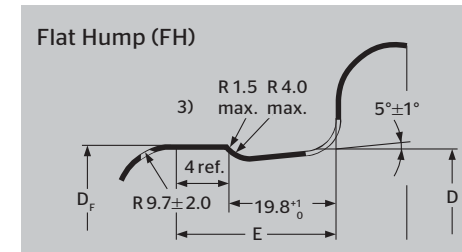
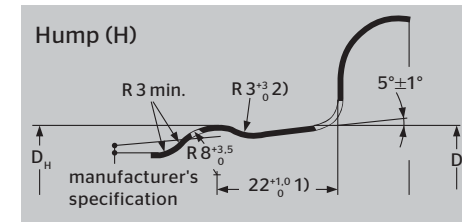

¹⁾ In most car rims 19.8 mm.
²⁾ For B-Rims R = 8.5 mm max. resp. R = 4 ± 1 mm.
³⁾ Deburred.

These full-drop centre rims with safety shoulders for cars, estate cars and light trucks are marked with the following-codes shown after rim size designation:

- H** = one-sided round hump on outer shoulder (formerly: H 1)
- H2** = double round hump
- FH** = flat hump on outer shoulder (formerly: FHA 1)
- FH2** = double flat hump (formerly: FHA 2)
- CH** = combination hump = flat hump on outer shoulder, round hump on inner shoulder (formerly: FHA-H)
- SL** = special ledge
- EH2/2+** = Extended Hump (with extended hump on both sides) (see following page)

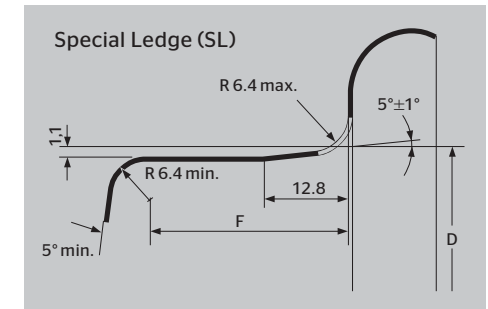

Ledge	Rim diameter Code (inch)	Dimensions (mm)		
		H	FH	
		Circumference TT · D _H (+ 0/-3)	Circumference TT · D _F (+ 0/-3)	E Max.
B	12	957.6	-	-
	13	1037.0	1034.8	24.5
	14	1116.8	1114.6	
J	13	1037.0	1034.8	28.5
	14	1116.8	1114.6	
	15	1196.6	1194.4	
	16	1276.4	1274.2	
	17	1373.8	1371.6	
	18	1453.6	1451.4	
	19	1533.4	1531.2	
	20	1613.2	1611.0	
	21	1693.0	1690.8	
	22	1772.8	1770.6	
	23	1852.6	1850.4	
24	1932.4	1930.2		

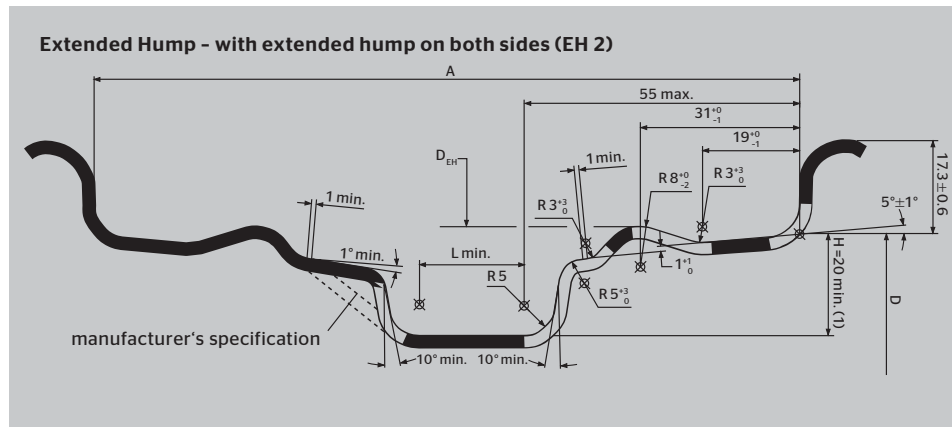

This contour is valid for rim sizes from 5 1/2 J to 13 1/2 J
(1): H ≥ 22 necessary for automatic fitting two beads at once

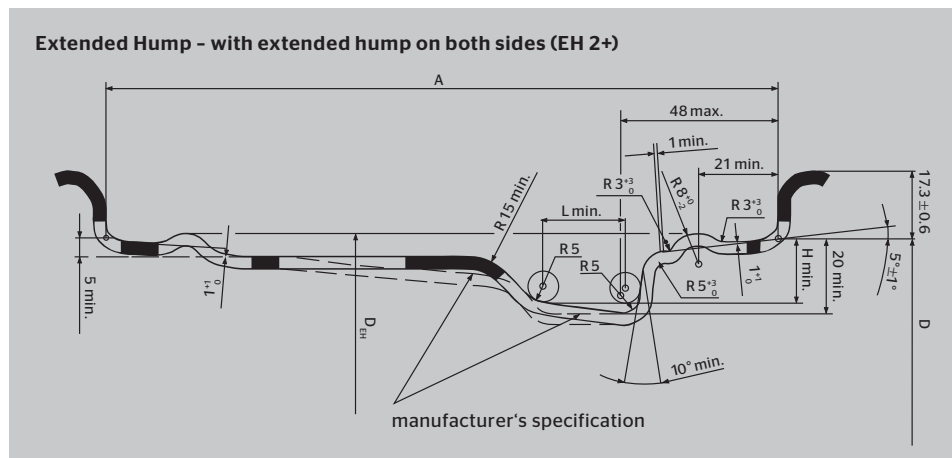

Extended Hump circumference

Rim diameter Code (inch)	Extended Hump circumference (mm) TT · D _{EH} (+ 0/-3)
15	1204.2
16	1284.0
17	1381.2
18	1461.0
19	1540.8
20	1620.6
21	1700.4



SAFETY WARNING!

The following instructions must be observed to ensure vehicle safety at all times. Disregarding the fitting instructions could endanger the safety of the tyre fitter or driver. This applies in particular to inflation pressure. Non-compliance with these instructions means risking tyre damage which, if serious enough, may result in a tyre bursting. It is an hazard like this that can cause traffic accidents involving vehicle damage and / or serious personal injury.

Correct choice of tyre and wheel

Tyres should only be chosen in accordance with vehicle documents and recommendations of the tyre manufacturer.

The dimensions and service descriptions of SSR runflat tyres*) (see page 23) correspond to those of standard tyres of the same size and construction. SSR tyres may only be fitted on vehicles for which they are approved by the vehicle manufacturer and that are equipped with a tyre pressure monitoring system (TPMS).

If tyres are changed to a different size, all legal requirements and regulations, as well as the recommendations of the vehicle, wheel and tyre manufacturers must be complied with. In any event, the freedom of motion of the wheel and adequate load capacity of the tyre must be observed.

*) only available for tyre brands Continental and Uniroyal

**) Exception: This does not apply to the UK

Tyre sizes and rims not entered in the vehicle registration document may only be fitted if the vehicle and tyre manufacturer issue a certificate of non-objection or if a public authority issues fitting approval after an inspection by an officially authorised expert **).

80 and 82 series passenger car tyres of the same size can be interchanged without new approval and without any new entry in the vehicle documents if Load Index (LI) and Speed Symbol (SSY) of the interchanging size are of an equivalent or higher grade quality. Example: 155/80 R 13 79 T replaces 155 R 13 79.

Mixed tyre constructions (radial or cross ply) for cars, caravans and other car trailers are not permitted: Tyres fitted on any one vehicle must all be either radial or cross ply. (Exception: Use of the spare tyre in an emergency).

The same applies to the choice of wheels (rims): The standard wheels approved by the vehicle manufacturer must be used as recommended.

The tyre widths given in the tables on pages 26-71 and 84-95 refer to the measuring rim (bold print in the tables). In the event of a change in the rim width by + 1/2 inch, the tyre width changes by approx. + 5 mm.

Winter tyres

Winter tyres are clearly superior in the cold months of the year; they offer a wider margin of safety and better economy when the temperature drops below 7 ° C.

Winter tyres approved for a max. speed lower than that of the vehicle may only be fitted if the max. speed of these tyres is displayed in full view of the driver, e. g. on a clearly visible sticker on the dashboard. This maximum tyre speed must not be exceeded.

A combination of summer and winter tyres on passenger cars is not recommended.

Winter tyres have to meet special requirements, meaning that the legal minimum tread depth of 1.6 mm is inadequate. **The suitability for winter use depends significantly on the tyres' tread depth.** In the interest of safety, Continental recommends replacing winter tyres before the tread depth drops below 4 mm for winter service.

Top safety in winter can be provided only by true winter tyres on all axle positions (4 tyres).



Snowflake designation:

This additional marking on an M + S tyre shows that the tyre meets prescribed test criteria and ensures good winter properties.

Brittleness temperature of rubber compounds - passenger tyres

Several performance aspects of tyres are influenced by temperature.

For example traction (wet and dry), rolling resistance, mileage and ride comfort.

To achieve optimum performance, Continental therefore recommends that winter tyres be used at temperatures below + 7 ° C and summer tyres at temperatures above + 7 ° C.

All-season tyres with M + S marking, although a compromise in certain performance aspects, are suitable for use in hot and cold temperatures.

The tread patterns and rubber compounds used in the above mentioned tyres are specifically designed and developed to offer optimum performance within the temperature range for which they are intended.

Summer tyres - especially Ultra High Performance (UHP) tyres

The highly developed, specialized tread compounds used in such tyres are designed to provide the highest possible levels of grip at ambient temperatures above + 7 ° C.

Such tread compounds are however **very sensitive to temperature.**

Permanent damage may occur to the tread compounds of such tyres if they are used at temperatures below - 20 °.

At this temperature, the tread compounds of UHP summer tyres may lose their elasticity and become brittle (the so-called brittleness point). When this occurs and the tyre is flexed, the tread compound may crack.

Therefore, UHP summer tyres should not be used at temperatures below - 20 ° C. Continental group tyres with an M + S marking on the sidewall are suitable for use down to - 45 ° C.



Fitting the tyre

SAFETY WARNING!

If a tyre is not properly fitted it may burst. The energy released in a blow-out can

cause fatal injuries so tyres must be fitted by an expert.

Only approved fitting tools and lubricants may be used. Observe all fitting instructions.

Because of the special technology involved, SSR runflat tyres*) may be mounted and removed only by specifically trained workshops that have been certified by Continental (see page 23).

Detailed mounting instructions for SSR runflat tyres*) under www.continental-tires.com/car/technology/extended-mobility-main/ssr

ContiSeal™ and ContiSilent™ tyres**)

do not differ from standard tyres in aspects such as mounting, demounting, inflating, and balancing. For detailed information see page 24 / 25 and www.contiseal.com resp. www.continental-tires.com/car/technology/contisilent

Before the old tyre is taken off the valve insert must be unscrewed and removed to ensure all air has escaped.

When removing tyres sealed with sealant

(e. g. ContiMobility Kit**) pay special attention to the following:

The tyre could contain up to ½ litre liquid sealant. Therefore:

- › Wear PE gloves when removing the tyre and make sure that the work area is well ventilated (to prevent odour build-up).
- › Make certain that the tyre is fully deflated before removal.
- › Move the wheel carefully so the sealant can collect at the lowest point in the tyre.
- › Drain all of the sealant before removing the tyre.
- › Dispose of remaining sealant in compliance with national regulations.

The new tyre and rim must have matching diameters and be approved as a combination for the vehicle model concerned. Only rims of the correct size in perfect condition and free of rust should be used. They must not be damaged, out of shape or worn. This applies in particular in combination with SSR runflat tyres *).

When fitting new tube-type tyres, always use **new tubes**. As tubes stretch in service, there is a risk of folds forming in old tubes, so re-used tubes could suddenly tear.

For safety reasons, tubeless tyres should always be fitted with **new valves**.

If rubber valves (snap-in types) are used for tubeless tyres, the vehicle manufacturer's instructions must be complied with in all cases. A **valve support** (i. e. a stopper on the rim itself or the hubcap) should be fitted, if H, V, W or Y tyres are specified for the vehicle. This ensures that valves are not forced off at high speeds.

Always coat the tyre beads and the rim with a **fitting lubricant** recommended by the tyre manufacturer. This applies in particular to low section tyres and SSR runflat tyres *). Never use greases or other hydrocarbons for this purpose.

While the tyre is being inflated, the wheel must remain firmly secured on the mounting machine. **Never inflate an unsecured tyre.**

*) only available for tyre brands Continental and Uniroyal

***) only available for tyre brand Continental

Keep a reasonable distance from any tyre that is being inflated. Make use of a sufficiently long and secured extension hose with an integrated pressure gauge. **Never bend over a tyre while it is being inflated.**

When fitting tubeless car tyres, care should be taken to ensure that the tyre beads coming from the well-base first clear the hump in the rim shoulder. To avoid cracks in the bead core, the “pop” pressure necessary should not exceed 3.3 bar. If the tyre does not pop into place even at this pressure, the pressure must be lowered, and the cause identified and eliminated. Then the procedure can be repeated.

Only when the tyre beads are seated correctly on the rim shoulder may the pressure be increased to achieve the required press-fit and firm grip on the rim flanges. However, this “fitting pressure” should not exceed 150 % of the max. pressure given in the tables or be more than 4.0 bar. After this, adjust the pressure to the **operating pressure** specified by the vehicle manufacturer (also see Continental tyre pressure table).

Car tyres should be **dynamically balanced**.

Fitting the wheel to the vehicle

If the tyres exhibit uneven wear then the axle geometry should be checked and corrected if necessary.

SSR runflat tyres*) may only be fitted on vehicles for which they are approved by the vehicle manufacturer and that are equipped with a tyre pressure monitoring system.

Valves should be fitted with **valve caps** – preferably with a sealing ring – as they protect the delicate **valve inserts** and the inside of the tyre.

When mounting **wheel caps and wheel trim rings**, sufficient clearance to the tyre sidewall must be maintained. The wheel cap or wheel trim ring may not come in contact with the tyre under any operating conditions. This applies in particular to tyres with rim protection (flange ribs “FR”).

Directional tyres must be fitted so that they roll in the direction of the arrow on the sidewall as the vehicle moves forward.

Exception: For a short-term use as a temporary fitment spare; but revert to specified fitted position at the earliest possible opportunity!

Asymmetrical tyres must be fitted with the sidewall ‘Outside’ on the outside of the vehicle so that their asymmetrical treads can be used to best effect.

Tyre pressure



SAFETY WARNING!
Incorrect tyre pressure can lead to the inside of the tyre being damaged. This can result in tyre failure or even a blowout.

Hidden tyre damages are not rectified by adjusting the tyre pressure.

Table 1:
Load capacities and tyre pressures – standard load car tyres
 (The tyre pressure values shown here apply to speeds up to 160 km/h (100 mph) and camber angles not greater than 2°)

Load Index	Load capacity (kg) at tyre pressure (bar)					
	2.0	2.1	2.2	2.3	2.4	2.5
62	220	230	240	250	255	265
63	230	235	245	255	265	272
64	235	245	255	260	270	280
65	245	250	260	270	280	290
66	250	260	270	280	290	300
67	255	265	275	285	295	307
68	265	275	285	295	305	315
69	270	285	295	305	315	325
70	280	290	300	315	325	335
71	290	300	310	325	335	345
72	295	310	320	330	345	355
73	305	315	330	340	355	365
74	315	325	340	350	365	375
75	325	335	350	360	375	387
76	335	350	360	375	385	400
77	345	360	370	385	400	412
78	355	370	385	400	410	425
79	365	380	395	410	425	437
80	375	390	405	420	435	450
81	385	400	415	430	445	462
82	395	415	430	445	460	475
83	405	425	440	455	470	487
84	420	435	450	470	485	500
85	430	450	465	480	500	515
86	445	460	480	495	515	530
87	455	475	490	510	525	545
88	470	485	505	525	540	560
89	485	505	525	545	560	580

*) only available for tyre brands Continental and Uniroyal

Load capacities and tyre pressures - standard load car tyres

(The tyre pressure values shown here apply to speeds up to 160 km/h (100 mph) and camber angles not greater than 2°)

Load Index	Load capacity (kg) at tyre pressure (bar)					
	2.0	2.1	2.2	2.3	2.4	2.5
90	500	520	540	560	580	600
91	515	535	555	575	595	615
92	525	550	570	590	610	630
93	545	565	585	610	630	650
94	560	585	605	625	650	670
95	575	600	625	645	670	690
96	595	620	640	665	685	710
97	610	635	660	685	705	730
98	625	650	675	700	725	750
99	650	675	700	725	750	775
100	670	695	720	750	775	800
101	690	720	745	770	800	825
102	710	740	765	795	825	850
103	730	760	790	820	845	875
104	755	785	815	840	870	900
105	775	805	835	865	895	925
106	795	825	860	890	920	950
107	815	850	880	910	945	975
108	835	870	905	935	970	1000
109	860	895	930	965	995	1030
110	885	920	955	990	1025	1060
111	910	950	985	1020	1055	1090
112	935	975	1010	1050	1085	1120
113	960	1000	1040	1075	1115	1150
114	985	1025	1065	1105	1140	1180
115	1015	1055	1095	1135	1175	1215
116	1045	1085	1130	1170	1210	1250

Table 2:**Load capacities and tyre pressures - Reinforced and Extra Load (XL and XL+) car tyres**

(The tyre pressure values shown here apply to speeds up to 160 km/h (100 mph) and camber angles not greater than 2°)

Load Index	Load capacity (kg) at tyre pressure (bar)									
	2.0	2.1	2.2	2.3	2.4	2.5	2.6	2.7	2.8	2.9
79	325	340	350	365	375	390	400	415	425	437
80	335	350	360	375	385	400	410	425	440	450
81	345	355	370	385	395	410	425	435	450	462
82	355	365	380	395	410	420	435	450	460	475
83	360	375	390	405	420	430	445	460	475	487
84	370	385	400	415	430	445	460	470	485	500
85	385	400	415	430	445	455	470	485	500	515
86	395	410	425	440	455	470	485	500	515	530
87	405	420	435	455	470	485	500	515	530	545
88	415	435	450	465	480	495	515	530	545	560
89	430	450	465	480	500	515	530	550	565	580
90	445	465	480	500	515	535	550	565	585	600
91	455	475	495	510	530	545	565	580	600	615
92	470	485	505	525	540	560	575	595	615	630
93	485	500	520	540	560	575	595	615	630	650
94	500	520	535	555	575	595	615	635	650	670
95	515	535	555	575	595	615	630	650	670	690
96	525	550	570	590	610	630	650	670	690	710
97	540	565	585	605	625	650	670	690	710	730
98	555	580	600	625	645	665	685	710	730	750
99	575	600	620	645	665	690	710	730	755	775
100	595	620	640	665	690	710	735	755	780	800
101	615	635	660	685	710	735	755	780	800	825
102	630	655	680	705	730	755	780	805	825	850
103	650	675	700	725	750	775	800	825	850	875
104	670	695	720	750	775	800	825	850	875	900
105	685	715	740	770	795	820	850	875	900	925
106	705	735	760	790	815	845	870	895	925	950
107	725	755	780	810	840	865	895	920	950	975
108	745	770	800	830	860	890	915	945	970	1000
109	765	795	825	855	885	915	945	975	1000	1030
110	785	820	850	880	910	940	970	1000	1030	1060
111	810	840	875	905	935	970	1000	1030	1060	1090
112	830	865	900	930	965	995	1025	1060	1090	1120
113	855	890	920	955	990	1020	1055	1085	1120	1150
114	875	910	945	980	1015	1050	1080	1115	1145	1180
115	905	940	975	1010	1045	1080	1115	1145	1180	1215
116	930	965	1000	1040	1075	1110	1145	1180	1215	1250
117	955	995	1030	1065	1105	1140	1180	1215	1250	1285
118	980	1020	1060	1095	1135	1170	1210	1245	1285	1320
119	1010	1050	1090	1130	1170	1210	1245	1285	1320	1360
120	1040	1080	1120	1165	1205	1245	1285	1320	1360	1400

The tyre must be inflated to the pressure specified by the vehicle and tyre manufacturer. This varies depending on the load and service conditions.

The pressure always refers to the cold tyre and must not be allowed to fall below this value. The pressure inside warm tyres - driving causes heat build-up - is naturally higher. So never reduce the pressure of warm tyres. Once they cool down, their pressure could fall below the specified **minimum tyre pressure**.

The tyre pressure must be checked and adjusted regularly every 14 days on the cold tyre.

The spare tyre may not be forgotten.

Incorrect tyre pressure causes premature and / or uneven tread wear. **Under-inflated** tyres have a higher **rolling resistance**, and this means a higher **fuel consumption**. In extreme cases underinflation may result in tyre failure.

The tyre pressure values for car tyres given in table 1 and 2 are **minimum pressures** for speeds up to 160 km/h (100 mph). They may be increased, for example, for reasons of driving stability. Please refer to the recommendation of the vehicle manufacturer.

3.2 bar is the **maximum tyre pressure** on standard version car tyres up to and including Speed Symbol T; 3.5 bar for H-, V-, W-, Y, as well as XL / Reinforced tyres. **These values may not be exceeded.**

ZR* tyres without service description have from 160 km/h (100 mph) to 190 km/h (118 mph) inclusive the stated pressure of 2.5 bar. Then the inflation pressure must be increased by 0.1 bar for each 10 km/h (6 mph) up to 3.5 bar at 240 km/h (150 mph) under full load and maximum 2 ° wheel camber.

Table 3:

For **higher speeds** the **tyre pressure** should be **increased** in regard of the load capacity (taken from the ETRTO Standards Manual):

Speed capacity of the vehicle (incl. tolerance, about 9 km/h, 6 mph) (km)	Speed Symbols									
	Q	R	S	T	U	H	V	W	Y	
	Tyre pressure*) (bar)									
≤160	2.5	2.5	2.5	2.5	2.5	2.5	2.5	2.5	2.5	2.5
170		2.6	2.6	2.6	2.6	2.6	2.6	2.6	2.5	2.5
180			2.6	2.6	2.6	2.6	2.6	2.6	2.5	2.5
190				2.7	2.7	2.7	2.7	2.7	2.5	2.5
200					2.7	2.7	2.7	2.7	2.6	2.5
210						2.8	2.8	2.7	2.5	
220							2.8	2.8	2.5	
230							2.8	2.9	2.6	
240							2.8	3.0	2.7	
250								3.0	2.8	
260									3.0	2.9
270									3.0	3.0
280										3.0
290										3.0
300										3.0

*) at the maximum load of the tyre, up to 2 ° wheel camber

Load capacity and speed

When determining the minimum tyre size necessary for a vehicle, the permitted **axle load** and the **maximum design speed** of the vehicle must be used as a basis.

The maximum load capacity of a car tyre is expressed through its **Load Index (LI)** (see page 8).

*) Obsolete designation, production until Nov., 2014.

Table 4:
Percentage of load capacity versus speed ¹⁾
 (taken from the ETRTO Standards Manual):

Speed capacity of the vehicle (incl. tolerance, about 1% V_{max} + 6,5 km/h) (km)	Speed Symbols				
	H	V	W	Y	(Y)
	%				
210	100	100	100	100	100
220	-	97	100	100	100
230	-	94	100	100	100
240	-	91	100	100	100
250	-	-	95	100	100
260	-	-	90	100	100
270	-	-	85	100	100
280	-	-	-	95	³⁾
290	-	-	-	90	³⁾
300	-	-	-	85	³⁾
>300 ²⁾	-	-	-	-	³⁾

¹⁾ For intermediate maximum speeds, linear interpolation of the tyre load capacity is permitted.

²⁾ For speeds over 300 km/h (187 mph), the relevant inflation pressures will be agreed between vehicle and tyre manufacturers (or their national associations), taking into consideration the vehicle characteristics and the type of service.

³⁾ (Y) tyres fulfill the requirements of Y tyres and could even be higher depending on the maximum speed. The load capacity of (Y) tyres has to be confirmed by the tyre manufacturer.

(For **ZR tyres** (production until Nov, 2014) without service description the maximum load capacity given in the tables from page 26 onwards applies to speeds up to 240 km/h (150 mph).

For speeds over 240 km/h (150 mph) please refer to us for load capacity and tyre pressure.)

If car tyres are to be used on a vehicle with a **wheel camber** of over 2°, please check load capacity and tyre pressure with us.

The load capacity of tyres in **twin fitment** is 1.85 times the load capacity of a single tyre.

The **load capacities** in the tables for car tyres can be increased if the tyres are fitted on vehicles with **the following low type-related** max. speeds and if the inflation pressure is increased at the same time (taken from the ETRTO Standards Manual):

Max. speed capability	(km/h)	60	50	40	30	25
Load capacity	(%)	110	115	125	135	142
Inflation pressure increase	(bar)	0.1	0.2	0.3	0.4	0.5

Tyre damage

Most tyre damage is caused by incorrect tyre pressure, so we recommend a regular tyre pressure check every 2 weeks. When the car has been driven and the tyres are warm, it is normal for the tyre pressure to increase. Never bleed warm tyres.

A balanced, even **style of driving** is beneficial for the tyres and the environment. Harsh acceleration, braking and fast cornering shorten the **service life** of tyres.

This applies equally to other types of **tyre usage** such as severe scuffing along the kerb, or driving over obstacles. This can cause hidden or visible **damage** to tyres.

Vibrations of the steering wheel could point to tyre damage. All the vehicle's tyres should be checked immediately for damage.

Overstressing of tyres (excessive speed or overloading), is to be avoided. This has the same critical effect as **under inflation** and can cause heat damage to the tyre.

Tyre rotation on a vehicle

The tyres on a vehicle should be rotated regularly to help ensure even wear and maximum tread life.

Tyres should be rotated as instructed in the vehicle owner's manual, with special attention being given to the **recommended interval for rotating tyres**. Unless otherwise specified by the vehicle manufacturer, tyres should be rotated every 10,000 to 12,000 kilometers - or even earlier if the tread shows signs of uneven wear. In the latter case, the vehicle's wheel alignment and pertinent mechanical components should be checked and corrected, if need be.

Full-size **spare tyres** (not temporary spares) of the same size and design as the tyres in use on the vehicle should be included in the tyre rotation. In conjunction with the rotation, the full-size spare tyre's inflation pressure should be checked and, if need be, corrected.

A tyre's **inflation pressure** must correspond to what is specified in the vehicle owner's manual for the respective tyre position (recommended inflation pressure may differ for the front- and rear axle tyres).

Tyre rotation may effect the **tyre pressure monitoring system** (TPMS). The vehicle owner's manual or a qualified service professional should be consulted in the event that the TPMS has to be adjusted or recalibrated.

The **rolling direction** of directional tyres should not be reversed when the tyres are rotated.

Mixing tyres should be avoided

Tyre size, Load Index (LI) and Speed Symbol (SSY) at all wheel positions should be in accordance with the vehicle manufacturer's specification. In many countries, this is a legal requirement.

Driving with a non-recommended mix of tyre sizes, designs and Speed Symbols can be dangerous. In the event that tyres of different sizes, designs, Load Index or Speed Symbol are to be fitted on a vehicle, the vehicle manufacturer's recommendations should be heeded and / or the advice of a qualified tyre specialist sought. Some vehicles leave the factory with different tyre sizes on the front and rear axles. This configuration must not be changed unless approved by the vehicle manufacturer.

No more than one temporary spare^{*)} should be used on a vehicle at any one time. A tyre of this kind may only be driven up to a maximum speed of 80 km/h and is intended for temporary use, as indicated on the tyre sidewall and / or on a label attached to the tyre or the wheel.

^{*)} only available for tyre brands Continental and Uniroyal
See page 72 ff.

Mounting new tyres on the rear axle

It is recommended that all tyres used on the vehicle be replaced at the same time. If this is not the case, at least all the tyres on the same axle should be replaced at the same time.

If only one axle set of tyres is replaced, it is recommended to fit the newest tyres on the rear axle.

Additional important tips regarding tyre position

The **spare tyre's** date of manufacture and condition (e. g. signs of cracking, remaining tread depth) should be checked regularly.

For 4-wheel drive and All Wheel drive vehicles, any special tyre fitment requirements in the vehicle owner's manual should be heeded - especially if the vehicle is equipped with electronic systems such as antilock brakes, traction control or stability control. Damage to the vehicle or its transmission can result if these requirements are not followed.

Winter tyres should be fitted to all wheel positions. They should not be mixed with all-season or summer tyres.

Tyre Storage Recommendations

These recommendations are intended for consumers, but they are also important for tyre dealers. For commercial applications of new and waste tyres (tyre dealers and fleets), there may be more stringent and legal restrictions. Please check local regulations.

ContiSeal™ tyres^{*)} should be stored under the same conditions as recommended here for non-ContiSeal™ tyres. Due to the potentially sticky nature of the inside of ContiSeal™ tyres, do not place any objects or material inside the tyre as they may become stuck and subsequently difficult to remove without damage to the tyre.

Tyres are compounded to resist normal deterioration caused e. g. by sunlight, humidity and ozone. Nevertheless, stored tyres should be protected against these and other potentially damaging conditions.

The longer the storage period, the more exposure there is to potential damage.

After dismantling from a vehicle the tyres should be thoroughly cleaned and inspected for damage. Remove all stones and debris from the grooves. Chalk marking the tyres with their wheel positions (FL for Front Left, RR for Rear Right, etc.) will help to find the correct positions according the rotational plan.

^{*)} only available for tyre brand Continental

General:

- › DO STORE TYRES where it is clean, dry and moderately ventilated.
- › **Moist conditions** should be avoided. Tyres destined for retreading / repairing should be thoroughly cleaned and dried out before such operations are performed.
- › DO STORE TYRES at **temperatures** not exceeding 35 ° C (95 F), preferable below 25 ° C (77 F). Direct contact with hot pipes and radiators must be avoided.
- › Also deep temperatures below the freezing point might lead to brittleness and tyres should be carefully warmed up before mounting.
- › DO STORE TYRES, if outdoors, protected by an opaque waterproof covering.
 - This is mandatory for ContiSilent™ tyres. Avoid creating a heat box or steam bath. Ensure proper ventilation.
- › DO STORE TYRES, if outdoors, where tyres are raised off the storage surface.
- › **AVOID STORING TYRES** on piers, ship decks, or other unprotected areas.
- › **AVOID STORING TYRES**, where they can be damaged by passing objects - lawn mower, bicycle, or garden tools.
- › **AVOID STORING TYRES** where the area is wet, oily, and / or greasy such as with gasoline or petroleum-based products. Also, do not store on or against sensitive surfaces where staining can take place.

Tyres with rims

Inflated



Do not stand them upright

hang them

or pile them (restack every four weeks)

Tyres without rims

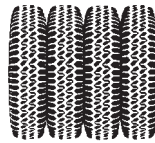

Do not pile them, or hang them

stand them upright and rotate them every four weeks
(on racks clear of floor)

- › **AVOID STORING TYRES** in the proximity of chemical agents like solvents, fuels, oils, hydrocarbons, paint, acids, disinfectants, etc.
- › **AVOID STORING TYRES** where subject to extreme temperatures, direct sunlight or artificial light with a high ultra-violet content. Room lighting with ordinary incandescent lamps is preferable to fluorescent tubes.

Never store them near battery chargers, ovens, or open fires.

- › **AVOID STORING TYRES** on black asphalt or other heat absorbent surfaces and on highly reflective surfaces (i. e., sand or snow covered ground).
- › **AVOID STORING TYRES** in the same area as an electric motor or other ozone generating source. If there is a question, check ozone levels to be sure they do not exceed 0.08 ppm.

- › **Do not** use tyres as a workbench or tool stand. Soldering irons, power drill and tools can damage a tyre.

Never put a burning cigarette on a pile of tyres.

Loose tyres or tyres mounted on rims, but not installed on a vehicle:

- › **DO STORE TYRES** so that they retain their shape.
- › Mounted tyres should preferable be inflated to only 100 kPa (15 psi / 1 bar).
- › **Be sure to adjust the tyres to the recommended inflation pressure before mounting on the vehicle.**

Tyres installed on a vehicle in long term storage:

- › If possible, store the vehicle on blocks to remove all weight from the tyres and cover the tyres to protect them from environmental exposure.
- › If the vehicle cannot be raised, completely unload it to reduce the load on the tyres. The storage surface should be firm, reasonably level, well drained, and clean.
- › In cases where the tyres will be supporting the vehicle, it is permissible to inflate the tyres to the maximum pressure listed on the sidewall. Be sure to return the inflation pressure to recommended usage pressure before operating the vehicle.
- › In cases where the tyres will be supporting the vehicle, it is recommended that the vehicle be moved every month to reduce the risk of a 'flat spot'. If the tyres do develop "flat spots," these will usually disappear in a short period of service.

Tyre repair



SAFETY WARNING!
Serious injury or death may result from a tyre disablement that is caused by failing to observe the following safety and maintenance information.

During its service life, a tyre undergoes a variety of different usage conditions and can be damaged in many different ways. This damage can result from punctures, impacts, cuts, etc. Tyre damage can reduce a tyre's structural integrity by, for example:

- › Air loss resulting in underinflated service conditions which lead to internal structural damage;
- › Direct damage to tyre components such as rubber and plies;
- › Exposure of internal materials to the outside environment and resulting degradation; and / or
- › Exposure of internal materials to pressurized air (Intra-carcass pressurization).

For these reasons, tyres should be regularly inspected by the consumer. An inspection of the tyres should also be incorporated during routine vehicle maintenance procedures. If tyre damage is suspected or found, it should be carefully assessed by a trained tyre specialist immediately.

ContiSeal™ tyres*) are designed to seal punctures in the tread from objects no larger than 5 mm diameter. Thoroughly inspect the tyre according to national industry standards. Carefully remove any object from the tyre tread. Even if the tyre seals, if it is punctured, the tyre must be removed from the rim and inspected carefully according to industry standards to determine whether a permanent repair can be made or whether the tyre must be removed from service and scrapped. A permanent repair will require removal of the tyre from the rim and application of a repair method specifically approved for ContiSeal™ tyres.

Among others, the tyre repair specialist, Rema TipTop has developed and approved instructions for the repair of ContiSeal™ tyres which can be found on the following website: www.contiseal.com

A consumer should never repair a damaged tyre. Only a trained tyre specialist who can base his assessment on a thorough and comprehensive inspection of the specific tyre can determine whether an individual tyre is suitable for repair or should be removed from service. This assessment should also take into account the complete service life history of the tyre including inflation, load, operating conditions, etc. If the tyre specialist decides to repair the tyre, then he should strictly follow all appropriate national tyre industry repair standards regarding the inspection process and repair procedures. Continental is not responsible for the specialist's decisions or the repaired tyre. Continental advises if a tyre is returned under complaint and reason for the product's disablement is in any way associated with a repair, or the reason for repair the manufacturer's warranty is invalidated. It is forbidden by law to regroove car tyres.

Tyre service life for passenger car and light truck

The tyre industry has long recognized the consumers' role in the regular care and maintenance of their tyres. The point at which a tyre is replaced is a decision for which the owner of the tyre is responsible. The tyre owner should consider factors to include service conditions, maintenance history, storage conditions, visual inspections, and dynamic performance. The consumer should consult a tyre service professional with any questions about tyre service life.

The following information and recommendations are made to aid in assessing the point of maximum service life.

Tyres are designed and built to provide many thousands of miles of excellent service. For maximum benefit, tyres must be maintained properly to avoid tyre damage and abuse that may result in tyre disablement. The service life of a tyre is a cumulative function of the storage, stowing, rotation and service conditions, which a tyre is subjected to throughout its life (load, speed, inflation pressure, road hazard injury, etc.). Since service conditions vary widely, accurately predicting the service life of any specific tyre in chronological time is not possible.

The consumer plays an important role in tyre maintenance.

Tyres should be removed from service for numerous reasons, including tread worn down to minimum depth, damage or abuse (punctures, cuts, impacts, cracks, bulges, underinflation, overloading, etc). For these reasons tyres, including spares, must be inspected routinely, i. e., at least once a month. Regular inspection becomes particularly important the longer a tyre is kept in service. If tyre damage is suspected or found, Continental recommends that the consumer have the tyre inspected by a tyre service professional. Consumers should use this consultation to determine if the tyres can continue in service. It is recommended that spare tyres be inspected at the same time. This routine inspection should occur whether or not the vehicle is equipped with a tyre pressure monitoring system (TPMS).

Consumers are strongly encouraged to be aware of their tyres' visual condition. Also, they should be alert for any change in dynamic performance such as increased air loss, noise or vibration.

Such changes could be an indicator that one or more of the tyres should be immediately removed from service to prevent a tyre disablement. Also, the consumer should be the first to recognize a severe in-service impact to a tyre and to ensure that the tyre is inspected immediately thereafter.

Tyre storage, stowage and rotation are also important to the service life of the tyre. More information regarding proper storage, stowage and rotation is located in other Continental publications, which are available upon request and through its websites.

*) only available for tyre brand Continental

Tyre service life recommendation

Continental is unaware of any technical data that supports a specific tyre age for removal from service. However, as with other members of the tyre and automotive industries, Continental recommends that all tyres (including spare tyres) that were manufactured more than ten (10) years previous ¹⁾ be replaced with new tyres, even when tyres appear to be usable from their external appearance and if the tread depth may have not reached the minimum wear out depth. Vehicle manufacturers may recommend a different chronological age at which a tyre should be replaced based on their understanding of the specific vehicle application; Continental recommends that any such instruction be followed. Consumers should note that most tyres would have to be removed for tread wear-out or other causes before any proscribed removal period. A stated removal period in no way reduces the consumer's responsibility to replace tyres as needed.

Minimum removal tread depth for passenger and light truck tyres

1.6 mm is the most widely accepted minimum tread depth standard at which tyres should be removed from service. This standard has been adopted as a regulation by many of the world's national transportation authorities. As an indication to the consumer, there are tread wear indicator bars in the main grooves of the tyre that become level with the tread surface at approximately 1.6 mm of remaining tread.

In addition to acknowledging the above, Continental recommends that all passenger and light truck tyres in highway motor vehicle application be removed from service at the following tread depths:

- › **summer / high performance tyres = 3 mm**
- › **winter tyres = 4 mm**

These recommendations are based upon Continental's testing as well as real world experience which shows that drivers can maintain the performance potential (e. g. wet grip) of their tyres by replacing them before they reach the **regulatory minimum tread depth of 1.6 mm**.

This applies especially to winter tyres for which winter driving properties such as snow traction are significantly reduced at tread depths below 4 mm.

Guidelines on tyre safety for drivers and vehicle operators (recommended for vehicle handbooks)

Tyres need to be properly handled if they are to keep you and other road users safe. So please note the following:

1. The **tyre pressure** must be as indicated in the operating instructions for your vehicle or as marked on the vehicle itself. The pressure applies to cold tyres; it must not be any lower. Tyres that have become warm, e. g. through driving, will increase in pressure. Never release air from warm tyres, or the pressure could fall below the minimum.

The pressure must be checked **every 14 days** when the tyres are cold. Don't forget to check the spare.

If the pressure is too low, heat may build up in the tyre and lead to internal damage.

At high speeds the tyre may fail as a result of previous internal damage. Tyre damage that cannot be seen is not put right simply by raising the pressure afterwards!

2. If you have to drive over kerbstones do it slowly and, if possible, at right angles. Don't drive up or against any steep or sharp-edged kerbstones or other objects (e. g. stones); this can lead to non-visible tyre damage which can cause problems later - **the tyre may fail when running at high speeds.**

3. Check tyres regularly for **damage**, such as stones, nails etc. that have penetrated the tyre, as well as any cuts, tears or bulges (in the sidewall). Foreign objects can also damage the inside of the tyre. Have your tyre dealer or specialist check your tyres if you are unsure of their condition. **Damaged tyres can burst.**
4. Never fit used tyres whose history you don't know. Remember that tyres age even when they are little used or not used at all. If you have a spare tyre and it has not been used for several years have it examined by a tyre specialist. We recommend that tyres (including the spare) should be removed from potential service if they were manufactured more than 10 years previous.
5. Check the **tread depth** of your tyres regularly. The lower the depth, the greater the **risk of aquaplaning**. Ensure that your tyres comply with the legally required tread depth.

¹⁾ Production code of tyres see page 7.

- A** Ageing _____ 126, 127
Aquaplaning _____ 127
- B** Brittleness temperature _____ 110
of rubber compounds
- C** Choice of tyre _____ 109
ContiMobilityKit _____ 76, 111
(tyre emergency set)
ContiSeal™ tyres _ 11, 12, 13, 14, 18, 19, 20,
21, 24, 111, 121, 124
ContSilent Technology 10, 11, 16, 18, 25, 121
CST (ContiSpareTyre) _____ 72-75
ContiTireSealant _____ 77
- D** Dimensions _____ 9, 26-71, 72-75, 84-94
DIN _____ 3
Directional tyres _____ 112, 120
DOT _____ 3, 7
- E** ECE _____ 3, 7
ETRTO _____ 117 ff.
- F** Fitting lubricant _____ 111
Fitting pressure _____ 112
Fuel consumption _____ 116
- H** H-rated tyres _____ 8, 111, 116, 117, 118
Higher grade tyres _____ 109
- I** Imprint _____ 4
Inflation pressure / _____ 3, 9, 112, 127
tyre pressure
ISO _____ 3, 9
- L** Load capacity _____ 8, 26-71, 72-75,
84-95, 96-104, 113-115, 117-118
Load Index _____ 8, 26-71, 72-75,
84-95, 113-115, 117
- M** Max. inflation pressure _____ 116
Max. speed _____ 7, 8, 117-118
Measuring rim _ 26-71, 72-75, 84-95, 109
Min. (tyre) pressure _____ 116
Min. tread depth _____ 126
Mixed tyre fitments _____ 109
- N** New tyres _____ 3, 111
- O** Offset depth _____ 105
Operating conditions _____ 3
Operating instructions _____ 109-127
Operating measurements _____ 9, 26-71,
72-75, 84-94
Operating pressure _____ 112
Overloading _____ 119
Overstressing _____ 119
- P** Production code _____ 7
- R** Regrooving _____ 124
Reinforced _____ 7, 115
Replacing 82-series by 80 _____ 109
Rims / Wheels _____ 105-108, 109, 111
Rim codes _____ 107
Rim dimensions _____ 106-108
Rim width _____ 26-71, 72-75, 84-94
Rolling circumference _____ 9, 26-71,
72-75, 84-95
Rolling resistance _____ 116
Runflat tyres SSR _ 10, 11, 13, 14, 16, 18, 19,
20, 22, 23, 109, 111, 112
- S** Safety warning _____ 3, 109, 110, 112, 123
Service description . 8, 26-71, 72-75, 84-94
Service life _____ 3, 125 f.
Sidewall marking _____ 6, 7
Size ranges
passenger / SUV _____ 10ff.
van tyres _____ 78ff.
Snowflake designation _____ 7, 110
Spare tyre _____ 8, 72-75, 120
Speed _____ 8, 117f., 127
Speed Symbol (SSY) _____ 8
SSR runflat tyres _ 10, 11, 13, 14, 16, 18, 19,
20, 22, 23, 109, 111, 112
Static radius _____ 26-71, 72-75, 84-95
Storage _____ 121
Style of driving _____ 119
Summer tyres _____ 10-17, 126
- T** Technical data _____ 26-71, 72-75, 84-95
Temperature (use of tyres) _____ 110
Trailers, car-drawn _____ 96-104
Tread depth _____ 7, 110, 126
Tubeless _____ 7
TWI (Tread Wear Indicators) _____ 7
Twin fitment _____ 118
Tyre ageing _____ 125-127
Tyre damages _____ 119, 123, 127
Tyre emergency set _____ 76, 111
ContiMobilityKit
Tyre fitting _____ 110-112
Tyre markings _____ 7
Tyre pressure / _____ 3, 9, 112, 127
inflation pressure
Tyre repairs _____ 123
Tyre Sealant _____ 77
Tyre service life _____ 3, 125f.
Tyre width _ 9, 26-71, 72-75, 84-94, 109
- U** Under-inflation _____ 116, 119
Units of measurements _____ 9
- V** V-rated tyres _____ 8, 111, 116, 117, 118
Valve caps _____ 112
Valve support _____ 111
Van tyres _____ 78-95
Vibrations _____ 119
- W** W-rated tyres _____ 8, 111, 116, 117, 118
Wheel camber _____ 118
Wheel caps / trim rings _____ 112
Wheel disc _____ 105
Wheels / rims _____ 105-108, 111
Winter tyres _ 7, 18-22, 81, 82, 109 f., 126
- X** XL (Extra Load) _____ 7, 115
- Y** Y-rated tyres _____ 8, 111, 116, 117, 118
- Z** ZR-rated tyres* _____ 8, 116, 118

* Obsolete tyre designation, production until Nov., 2014.

D	Continental Reifen Deutschland GmbH Head Office:	Büttnerstraße 25 30165 Hannover P.O.B. 169 30001 Hannover	Telephone: ++49-511-9 38-01 Telefax: ++49-511-938-81770
A	Semperit Reifen Ges. m. b. H. Marketing + Vertrieb Österreich	Triester Strasse 14 2351 Wiener Neudorf	Telephone: ++43-22 36-40 40-0 Telefax: ++43-22 36-40 40-40 01
B	Continental Benelux S. A	Excelsiorlaan 61 1930 Zaventem	Telephone: ++32-2710 22 11 Telefax: ++32-2710 22 90
CH	Continental Suisse SA	Lerzenstrasse 19A 8953 Dietikon	Telephone: ++41-44 / 7 45 56 00
CZ	Continental Barum sr. o.	76531 Otrokovice Objizdne 1628	Telephone: ++420 577 511 111
DK	Continental Dæk Danmark A / S	Banemarksvej 50 E, 1 2605 Brøndby	Telephone: ++45-43 23 04 00 Telefax: ++45-43 23 04 01
E	Continental Tires España, S. A.	Avda Castilla 1 Edificio 1 Planta 2 28830 San Fernando de Henares (Madrid)	Telephone: ++34-91-660 36 57 Telefax: ++34-91-675 68 22
F	Continental France SNC Division Commerce	Lieudit le Bac à l'aumône 60605 Compiègne	Telephone: ++33-3-44 40 71 11 Telefax: ++33-3-44 40 74 89
GB	Continental Tyre Group Ltd.	191-195 High Street Yiewsley Middlesex, UB7 7QP	Telephone: ++44-1895 425900 Telefax: ++44-1895 425908
H	Continental Hungaria Kft.	Távíró Kóz 2-4 2040 Budaörs	Telephone: ++36-23-33 59 01 Telefax: ++36-23-33 54 63
I	Continental Italia S. p. A.	Via Pietro Rondoni 1 20146 Milano	Telephone: ++39-02-42 4101 Telefax: ++39-02-42 4102 00
N	Continental Dekk Norge A / S	Breivollveien 31 667 Oslo	Telephone: ++47-23 06 80 00 Telefax: ++47-23068001
NL	Continental Banden Groep B. V.	Nijverheidsweg 50 3771 ME Barneveld	Telephone: ++31-3-42 49 72 00 Telefax: ++31-3-42 49 72 91
P	Continental Pneus S. A.	4764-603 Lousado Apartado 5029 Rua Adelino Leitao 330	Telephone: ++351-252-49 92 34 Telefax: ++351-252-49 36 23
PL	Continental Opony Polska Sp. zo. o.	Zwirki i Wigury 16c 02092 Warszawa	Telephone: ++48-22-5 7713 00 Telefax: ++48-22-5 7713 01
S	Continental Däck Sverige AB	Banehagsgatan 22 41451 Göteborg	Telephone: ++46-31-7 75 80 00 Telefax: ++46-31-24 68 50
SF	Continental Rengas Oy	PL 2 Hevosenkenta 3 02661 Espoo	Telephone: ++358-9-329 900 Telefax: ++358-9-32990 400

For general instructions and explanation about technical tyre data see p. 9.

For specific explanation of footnotes in the table headers see here:

Passenger car tyres / 4x4 tyres

- 1) Instead of J-rims the same size JK- and JJ-rims may be used.
- 2) Winter tyres can be max. 1 % greater in outer diameter than standard on-road tread patterns.
- 3) According to DIN 70020 at 37 mph (60 km/h).
- 4) Instead of B-rims, J- and JK-rims may also be used.
- 5) The respective B-rims are permitted.
- * ZR tyres have no operational code. The LI given for these tyres is only an approx. figure. Ask Continental Customer Services for the actual speed and load capacity.

Van tyres

- 6) Load Index single / twin fitment and Speed Index.
- 7) Dual spacing for twin tyre fitments: See Technical Data Book for Truck Tyres.
- 8) Standard = on road tread pattern, Special = M + S or off road tread pattern.
- 9) S = Single, T = Twin fitment, FA = front axle, RA = rear axle.

For tyre pressures see "Operating instructions", page 112ff.

