

U-Joints for Passenger
Cars & Trucks
2007-2011



Changes from original:

Page 58, Part# 5-2002X, S2 = 1.312

Page 52, K1 and K2 "Between Snap Ring" Dimensions for OE Mfg. Spicer, OE Series SPL30 changed from 2.288 to 2.409

Pages 59-60, Corrected bolt part numbers in multiple notes; corrected centerline to centerline dimension for 050A89000.

SPICER[®]

DRIVETRAIN COMPONENTS



Genuine Spicer Life Series[®] (SPL[®])

Premium Performance U-Joint Packs

**Spicer Parts are there when you hit
the trail—and when the trail hits back.**

No matter what conditions you throw at your 4WD vehicle, trust non-greaseable Spicer SPL U-joints with the triple lip seal for premium performance. And when you need it, Spicer 4WD U-joint Performance Packs have everything for a complete U-joint change-out—with just one part number to order. See back for the Spicer 4WD U-joint Performance Pack that's right for you, and talk to your Spicer sales representative for more details. For a complete listing of applications, please visit www.spicerparts.com/literature and download the catalog "K350-1-DSSP" from the Driveshaft section.

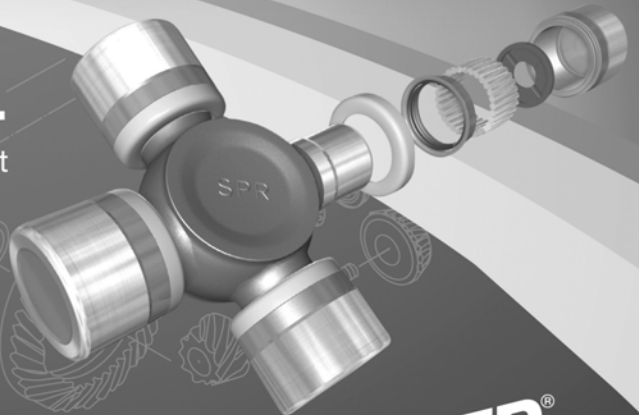

Passenger Car

DODGE	1
VIPER	1
FORD	1
CROWN VICTORIA	1
MUSTANG	1
LINCOLN	1
TOWN CAR	1
MERCURY	1
GRAND MARQUIS	1

Two Wheel Drive (2WD)

BUICK	2
RAINIER	2
CADILLAC	2
ESCALADE	2
CHEVROLET	2
AVALANCHE	2
COLORADO	2
EXPRESS 1500	2
EXPRESS 2500	2
EXPRESS 3500	3
SILVERADO 1500	6
SILVERADO 1500 CLASSIC	6
SILVERADO 2500HD	6
SILVERADO 3500	7
SUBURBAN 1500	7
SUBURBAN 2500	7
TAHOE	7
TRAILBLAZER	7
CHRYSLER	7
ASPEN LIMITED	7
DODGE	7
1500	7
2500	7
3500	8
DAKOTA	8
DURANGO	8
RAM 1500	8
RAM 2500	9
RAM 3500	10
FORD	12
E150	12
E250	12
E350 SUPER DUTY	12
E450 SUPER DUTY	12
EXPEDITION	12
EXPLORER	12
F150	13
F250	13
F350	13
F450	13
F550	13
RANGER	13

GMC	13
CANYON	13
ENVOY	13
SAVANA 1500	13
GMC	14
SAVANA 2500	14
SAVANA 3500	14
SIERRA 1500	16
SIERRA 2500 HD	16
SIERRA 3500	17
SIERRA DENALI	17
YUKON	17
ISUZU	17
ASCENDER	17
I-290	17
JEEP	17
LIBERTY	17
LINCOLN	18
MARK LT	18
LINCOLN	18
NAVIGATOR	18
MAZDA	18
B2300	18
B3000	18
B4000	18
MERCURY	18
MARINER	18
MOUNTAINEER	18
MINI	18
RAIDER	18
NISSAN	18
ARMADA	18
FRONTIER	18
PATHFINDER	18
TITAN	19
XTERRA	19
SUZUKI	19
EQUATOR	19
TOYOTA	19
4RUNNER	19
FJ CRUISER	19
SEQUOIA	19
TACOMA	19
TUNDRA	19

Four Wheel Drive (4WD)

AAM GENERAL/HUMMER	20
H2	20
H3	20
BUICK	20
RAINIER	20
CADILLAC	20
ESCALADE	20



Table of Contents

K350

CHEVROLET.....	20	NISSAN.....	36
AVALANCHE.....	20	ARMADA.....	36
COLORADO PICK-UP.....	20	FRONTIER PICK-UP.....	36
G-10 SERIES, G1500 SERIES AND EXPRESS.....	20	PATHFINDER.....	36
SILVERADO 2500HD.....	21	TITAN PICK-UP.....	36
SILVERADO 3500.....	22	XTERRA.....	36
SUBURBAN 1500.....	23	SAAB.....	36
SUBURBAN 2500.....	23	9-7X.....	36
TAHOE.....	23	SUZUKI.....	37
TRAILBLAZER.....	23	EQUATOR.....	37
CHRYSLER.....	23	TOYOTA.....	37
ASPEN LIMITED.....	23	4-RUNNER.....	37
DODGE.....	23	LAND CRUISER.....	37
DAKOTA.....	23	SEQUOIA.....	37
DURANGO.....	24	TACOMA.....	37
RAM 1500.....	24	TUNDRA.....	37
RAM 2500.....	24		
RAM 3500 PICK-UP.....	26	Spicer® Driveshaft Lubrication Specifications.....	39
FORD.....	28	Common U-Joint Kits By Series.....	40
ESCAPE.....	28	Driveline Conversion Kits.....	41
EXPEDITION.....	28	Universal Joint Kit Attaching Hardware & Torque Specifications.....	42
EXPLORER.....	28	U-Joint Kit Method of Retention and Hardware Kit Part Numbers.....	44
F150.....	28		
F250.....	29	Outside Snap Ring Style.....	45
F350 SUPER DUTY.....	29	Inside Snap Ring Style.....	51
F450 SUPER DUTY.....	31	Outside Snap Ring/Inside Snap Ring Style.....	54
F550 SUPER DUTY.....	31	Outside Snap Ring/Wing Bearing Style.....	56
RANGER.....	31	Inside Snap Ring/Wing Bearing Style.....	57
GMC.....	31	Wing Bearing Style.....	58
CANYON.....	31	Bearing Plate/Wing Bearing Style.....	62
ENVOY.....	31	Spicer Life Series™ (Spring Tab Style).....	63
SAVANA 1500.....	32	Bearing Plate Style.....	64
SIERRA 1500.....	32	Half Round Style.....	65
SIERRA 2500.....	32	Pot Style.....	66
SIERRA 3500.....	33	Threaded Cap style.....	67
SIERRA DENALI.....	34	Threaded Plate style.....	68
YUKON.....	34	Cap & Bolt Style.....	69
ISUZU.....	34	Outside Snap Ring style GWB.....	70
ASCENDER.....	34	Supersession List.....	71
I-370.....	35		
JEEP.....	35		
LIBERTY.....	35		
WRANGLER.....	35		
LEXUS.....	35		
LINCOLN.....	35		
MARK LT.....	35		
NAVIGATOR.....	35		
MAZDA.....	35		
B3000.....	35		
B4000.....	36		
MERCURY.....	36		
MOUNTAINEER.....	36		
MITSUBISHI.....	36		
RAIDER.....	36		

Year	Model & Description	Fig.	Location	Spicer Part No.	SPL Part No.
DODGE					
VIPER					
2008-2010		A	1,2	5-178X	5-1350X
FORD					
CROWN VICTORIA					
2007-2008		A	1,2	5-178X	5-1350X
2009-2011	LX, POLICE	A	1,2	5-178X	5-1350X
MUSTANG					
2011	Cobra	A	1,2	5-178X	5-1350X
LINCOLN					
TOWN CAR					
2007-2011		A	1,2	5-178X	5-1350X
MERCURY					
GRAND MARQUIS					
2007-2011		A	1,2	5-178X	5-1350X

PASS

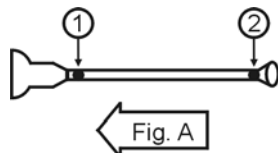

Important: See Safety Information in General Information Section (J300P-GI)

Year	Model & Description	Fig.	Location	Spicer Part No.	SPL Part No.
BUICK					
RAINIER					
2007		A	1,2	5-3147X	5-795X
CADILLAC					
ESCALADE					
2007-2008	ESV	A	1,2	5-178X	5-1350X
	Except ESV	A	1,2	5-3147X	5-795X
2009-2011		A	1,2	5-178X	5-1350X
CHEVROLET					
AVALANCHE					
2007-2008	w/5.3L Eng.	A	1,2	5-3147X	5-795X
	w/6.0L Eng.	A	1,2	5-178X	5-1350X
2009-2011		A	1,2	5-178X	5-1350X
COLORADO					
2007-2011		A	1	5-213X	5-1330X
		A	2	5-212X	5-7436X
		S	1,2	5-213X	5-1330X
		S	3	5-212X	5-7436X
EXPRESS 1500					
2007-2008	alum. driveshaft	A	1,2		5-3615X
2009-2011		A	1,2	5-178X	5-1350X
EXPRESS 2500					
2007	135" WB w/alum. driveshaft	A	1,2		5-3615X
	155" WB	S	1,2,3	5-178X	5-1350X
2008-2010	135" WB	A	1,2	5-178X	5-1350X
	155" WB	S	1,2,3	5-178X	5-1350X
2011	w/Spicer driveshaft				
	w/4.8L & 6.0L FF Eng. 135" WB	A	1,2	5-160X	5-1410X
	155" WB	S	1,2,3	5-160X	5-1410X
	w/AAM driveshaft				
	w/6.6L Diesel Eng. 135" WB AAM 1485 Series	A	1,2	5-3206X	
	155" WB AAM 1485 Series	S	1,2,3	5-3206X	

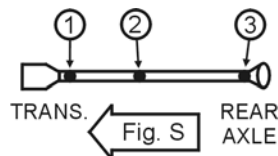
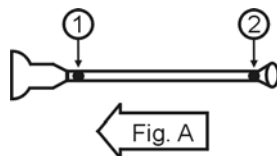

Year	Model & Description	Fig.	Location	Spicer Part No.	SPL Part No.
CHEVROLET					
EXPRESS 3500					
2007	w/4.8L Gas Eng.				
	135" WB w/alum. driveshaft	A	1,2		5-3615X
	139" WB Dual rear wheels	A	1,2	5-160X	5-1410X
	139" WB Single rear wheels, alum. driveshaft	A	1,2		5-3615X
	155" WB	S	1,2,3	5-178X	5-1350X
	159" WB	S	1	5-178X	5-1350X
		S	2,3	5-160X	5-1410X
	w/6.0L Gas Eng.				
	135" WB, LS & LT except LS & LT, w/alum. driveshaft	A	1,2	5-178X	5-1350X
		A	1,2		5-3615X
	139" WB Dual rear wheels	A	1,2	5-160X	5-1410X
	139" WB Single rear wheels LS & LT	A	1,2	5-178X	5-1350X
		A	1,2		5-3615X
	155" WB	S	1,2,3	5-178X	5-1350X
	159" WB	S	1	5-178X	5-1350X
		S	2,3	5-160X	5-1410X
	w/6.6L Diesel Eng.				
	135" WB, alum. driveshaft	A	1,2		5-3615X
	139" WB Dual rear wheels	A	1,2	5-160X	5-1410X
	139" WB Single rear wheels, w/alum. driveshaft	A	1,2		5-3615X
	155" WB	S	1,2,3	5-178X	5-1350X
159" WB	S	1	5-178X	5-1350X	
	S	2,3	5-160X	5-1410X	

2WD

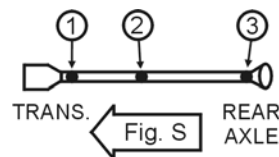
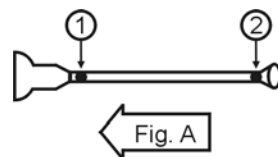

Important: See Safety Information in General Information Section (J300P-GI)

2WD

Year	Model & Description	Fig.	Location	Spicer Part No.	SPL Part No.	
CHEVROLET						
EXPRESS 3500						
2008	w/4.8L Gas Eng. 135" WB 139" WB Dual rear wheels Single rear wheels 155" WB 159" WB	A	1,2	5-178X	5-1350X	
		A	1,2	5-160X	5-1410X	
		A	1,2	5-178X	5-1350X	
		S	1,2,3	5-178X	5-1350X	
		S	1	5-178X	5-1350X	
		S	2,3	5-160X	5-1410X	
	w/6.0L Gas Eng. 135" WB 139" WB Dual rear wheels Single rear wheels 155" & 159" WB	A	1,2	5-178X	5-1350X	
		A	1,2	5-160X	5-1410X	
		A	1,2	5-178X	5-1350X	
		S	1,2,3	5-178X	5-1350X	
		w/6.6L Diesel Eng. 135" WB 139" WB Dual rear wheels Single rear wheels 155" WB 159" WB	A	1,2	5-178X	5-1350X
			A	1,2	5-160X	5-1410X
	A		1,2	5-178X	5-1350X	
	S		1,2,3	5-178X	5-1350X	
	S		1	5-178X	5-1350X	
	S	2,3	5-160X	5-1410X		
	2009	w/4.8L Gas Eng. 135" WB 139" WB Dual rear wheels Single rear wheels 155" WB 159" WB	A	1,2	5-178X	5-1350X
			A	1,2	5-160X	5-1410X
			A	1,2	5-178X	5-1350X
			S	1,2,3	5-178X	5-1350X
			S	1	5-178X	5-1350X
S			2,3	5-160X	5-1410X	
w/6.0L Gas Eng. 135" WB 139" WB Dual rear wheels Single rear wheels 155" WB 159" WB		A	1,2	5-178X	5-1350X	
		A	1,2	5-160X	5-1410X	
		A	1,2	5-178X	5-1350X	
		S	1,2,3	5-178X	5-1350X	
		S	1	5-178X	5-1350X	
		S	2,3	5-160X	5-1410X	
w/6.6L Diesel Eng. 135" WB 139" WB Dual rear wheels Single rear wheels 155" WB 159" WB		A	1,2	5-178X	5-1350X	
		A	1,2	5-160X	5-1410X	
		A	1,2	5-178X	5-1350X	
		S	1,2,3	5-178X	5-1350X	
		S	1	5-178X	5-1350X	
S		2,3	5-160X	5-1410X		



Year	Model & Description	Fig.	Location	Spicer Part No.	SPL Part No.		
CHEVROLET							
EXPRESS 3500							
2010	w/4.8L FF Eng. 135" WB 139" WB Dual rear wheels Single rear wheels 155" WB 159" WB	A	1,2	5-178X	5-1350X		
		A	1,2	5-160X	5-1410X		
		A	1,2	5-178X	5-1350X		
		S	1,2,3	5-178X	5-1350X		
		S	1	5-178X	5-1350X		
		S	2,3	5-160X	5-1410X		
	w/6.0L FF Eng. 135" WB 139" WB w/AAM driveshaft Dual rear wheels AAM 1485 Series w/Spicer driveshaft Single rear wheels 155" WB LT except LT 159" WB w/Spicer driveshaft w/AAM driveshaft AAM 1485 Series	A	1,2	5-160X	5-1410X		
		A	1,2	5-3206X			
		A	1,2	5-160X	5-1410X		
		S	1,2	5-160X	5-1410X		
		S	3	5-178X	5-1350X		
		S	3	5-160X	5-1410X		
		S	1,2,3	5-160X	5-1410X		
		S	1,2,3	5-3206X			
		w/6.6L Diesel Eng. 135" WB 139" WB Dual rear wheels Single rear wheels 155" WB 159" WB	A	2	5-178X	5-1350X	
			A	1,2	5-160X	5-1410X	
			A	1,2	5-178X	5-1350X	
			S	1,2,3	5-178X	5-1350X	
	S		1	5-178X	5-1350X		
	S		2,3	5-160X	5-1410X		
	2011	4.8L FF Eng. 135" WB w/AAM driveshaft AAM 1485 Series 139" WB w/Spicer driveshaft Dual rear wheels w/AAM driveshaft Single rear wheels AAM 1485 Series 155" WB 159" WB w/AAM driveshaft AAM 1485 Series	A	1,2	5-3206X		
			A	1,2	5-160X	5-1410X	
			A	1,2	5-3206X		
			S	1,2,3	5-3206X		
S			1	5-3206X			
S			2,3	5-160X	5-1410X		
6.0L FF Eng. 135" WB w/Spicer driveshaft 139" WB w/AAM driveshaft Dual rear wheels AAM 1485 Series w/Spicer driveshaft Single rear wheels 155" WB LS & LT except LS & LT 159" WB w/Spicer driveshaft w/AAM driveshaft AAM 1485 Series		A	1,2	5-160X	5-1410X		
		A	1,2	5-3206X			
		A	1,2	5-160X	5-1410X		
		S	1,2	5-160X	5-1410X		
		S	3	5-178X	5-1350X		
		S	3	5-160X	5-1410X		
		S	1,2,3	5-160X	5-1410X		
		S	1,2,3	5-3206X			
		6.6L Diesel Eng. w/AAM driveshaft 135" WB AAM 1485 Series 155" WB AAM 1485 Series	A	1,2	5-3206X		
			S	1,2,3	5-3206X		

2WD



Important: See Safety Information in General Information Section (J300P-GI)

2WD

Year	Model & Description	Fig.	Location	Spicer Part No.	SPL Part No.
CHEVROLET					
SILVERADO 1500					
2007-2008	LS	A	1,2	5-178X	5-1350X
	LT, LTZ & WT 157.5" WB Exc. 157.5" WB	S	1,2,3	5-178X	5-1350X
		A	1,2	5-178X	5-1350X
2009	HYBRID	A	1,2	5-178X	5-1350X
	LS	A	1,2	5-178X	5-1350X
	LT, LTZ & WT 157.5" WB	S	1,2,3	5-178X	5-1350X
2010	HYBRID, LS & XFE	A	1,2	5-178X	5-1350X
	LS, LT, LTZ & WT 157.5" WB Exc. 157.5" WB	S	1,2,3	5-178X	5-1350X
		A	1,2	5-178X	5-1350X
2011	HYBRID	A	1,2	5-178X	5-1350X
	LS, LT, LTZ & WT 157.5" WB Exc. 157.5" WB	S	1,2,3	5-178X	5-1350X
		A	1,2	5-178X	5-1350X
	XFE	A	1,2	5-178X	5-1350X
SILVERADO 1500 CLASSIC					
2007	119" & 134" WB	A	1,2	5-3147X	5-795X
	133" WB	A	1	5-213X	5-1330X
		A	2	5-212X	5-7436X
	HD LT, alum. driveshaft	S	1,2,3		5-3615X
	LS 143.5" WB w/AT	S	1,2,3	5-213X	5-1330X
	LS & WT 143.5" WB w/MT	S	1,2	5-213X	5-1330X
		S	3	5-212X	5-7436X
	LS, LT & WT 157.5" WB	S	1,2,3	5-3147X	5-795X
	LT 143.5" WB	S	1,2,3	5-3147X	5-795X
	SS	S	1,2,3	5-178X	5-1350X
	WT 143.5" WB w/AT	S	1,2,3	5-3147X	5-795X
	SILVERADO 2500HD				
2007	CLASSIC LS, LT & WT	S	1,2,3	5-160X	5-1410X
	LT, LTZ & WT w/Spicer driveshaft w/AAM driveshaft AAM 1485 Series	S	1,2,3	5-160X	5-1410X
		S	1,2,3	5-3206X	
2008-2010	LT, LTZ & WT w/Spicer driveshaft w/AAM driveshaft AAM 1485 Series	S	1,2,3	5-160X	5-1410X
		S	1,2,3	5-3206X	
2011	LT, LTZ & WT w/6.0L FF Eng. w/Spicer driveshaft Exc. 133" WB, w/AAM driveshaft AAM 1485 Series	S	1,2,3	5-160X	5-1410X
		S	1,2,3	5-3206X	
	w/6.6L Diesel Eng. w/Spicer driveshaft w/AAM driveshaft AAM 1485 Series	S	1,2,3	5-160X	5-1410X
		S	1,2,3	5-3206X	

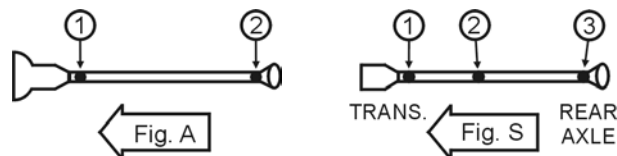

Year	Model & Description	Fig.	Location	Spicer Part No.	SPL Part No.
CHEVROLET					
SILVERADO 3500					
2007	CLASSIC LS, LT & WT w/Spicer driveshaft	S	1,2,3	5-160X	5-1410X
	LT, LTZ & WT w/AAM driveshaft AAM 1485 Series	S	1,2,3	5-3206X	
2008-2011	w/Spicer driveshaft	S	1,2,3	5-160X	5-1410X
	w/AAM driveshaft AAM 1485 Series	S	1,2,3	5-3206X	
SUBURBAN 1500					
2007-2008	LS, LT & LTZ w/5.3L Gas & FF Eng.	A	1,2	5-3147X	5-795X
	LT & LTZ w/6.0L Gas Eng.	A	1,2	5-178X	5-1350X
2009	LS, LT & LTZ w/5.3L Gas & FF Eng.	A	1,2	5-178X	5-1350X
	LT & LTZ w/6.0L Gas Eng.	A	1,2	5-178X	5-1350X
2010-2011	LS, LT & LTZ w/5.3L FF Eng.	A	1,2	5-178X	5-1350X
SUBURBAN 2500					
2007	LS, LT & LTZ w/6.0L Gas Eng.	A	1,2	5-178X	5-1350X
2008-2009	LS & LT w/6.0L Gas Eng.	A	1,2	5-160X	5-1410X
2010-2011	LS & LT w/6.0L FF Eng.	A	1,2	5-160X	5-1410X
TAHOE					
2007		A	1,2	5-3147X	5-795X
2008	HYBRID	A	1,2	5-178X	5-1350X
	LS, LT & LTZ	A	1,2	5-3147X	5-795X
2009-2011		A	1,2	5-178X	5-1350X
TRAILBLAZER					
2007	LS & LT	A	1,2	5-3147X	5-795X
	SS	A	1,2	5-178X	5-1350X
2008	Basic & LT	A	1,2	5-3147X	5-795X
	SS	A	1,2	5-178X	5-1350X
2009	LT & SS	A	1,2	5-178X	5-1350X
CHRYSLER					
ASPEN LIMITED					
2007-2009		A	1,2	5-3147X	5-795X
DODGE					
1500					
2011		A	1,2	5-178X	5-1350X
		S	1,2,3	5-213X	5-1330X
2500					
2011	w/AT, AAM driveshaft AAM 1415 Series	A	1,2	5-3207X	
	w/MT	A	1,2	5-188X	SPL55X
	w/AT	S	1,2,3	5-160X	SPL36-1X
	w/MT	S	1,2,3	5-188X	SPL55X

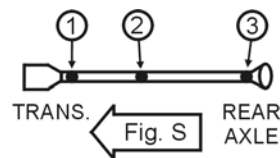
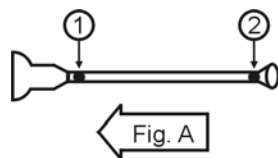

2WD

Year	Model & Description	Fig.	Location	Spicer Part No.	SPL Part No.
DODGE					
3500					
2011	LARAMIE, SLT & ST w/2-Joint shaft w/5.7L Gas Eng. w/AT, AAM 1415 Series w/MT w/6.7L Diesel Eng. 1.188" cap dia. 1.375" cap dia.	A	1,2	5-3207X	
		A	1,2	5-188X	SPL55X
		A	1,2	5-160X	SPL36-1X
		A	1,2	5-188X	SPL55X
	LARAMIE, SLT & ST w/3-Joint shaft w/5.7L Gas Eng. w/AT w/MT w/6.7L Diesel Eng. Crew Cab, w/AAM driveshaft, AAM 1485 Series Std & Ext Cab w/Spicer driveshaft	S	1,2,3	5-160X	SPL36-1X
		S	1,2,3	5-188X	SPL55X
		S	1,2,3	5-3206X	
		S	1,2,3	5-160X	SPL36-1X
DAKOTA					
2007-2011		A	1,2	5-213X	5-1330X
		S	1,2,3	5-213X	5-1330X
DURANGO					
2007-2009	w/4.7L FF Eng.	A	1,2	5-3147X	5-795X
RAM 1500					
2007	LARAMIE & SLT w/5.7L Gas Eng., w/AAM driveshaft, AAM 1415 Series LARAMIE, SLT, SPORT & ST w/5.7L Gas Eng. w/Spicer driveshaft SLT & ST w/4.7L Eng. ST w/3.7L Gas Eng. w/5.7L Gas Eng.	S	1,2,3	5-3207X	
		S	1,2,3	5-213X	5-1330X
		S	1,2,3	5-213X	5-1330X
		S	1,2,3	5-213X	5-1330X
		A	1,2	5-213X	5-1330X
2008	2-Joint shaft LARAMIE, SLT & STX w/5.7L Gas Eng. w/AAM driveshaft, AAM 1415 Series LARAMIE, SLT, ST & STX w/5.7L Gas Eng. w/Spicer driveshaft SLT, ST & STX w/4.7L Eng. ST & STX w/3.7L Gas Eng.	A	1,2	5-213X	5-1330X
		S	1,2,3	5-3207X	
		S	1,2,3	5-213X	5-1330X
		S	1,2,3	5-213X	5-1330X
		S	1,2,3	5-213X	5-1330X
2009-2010		A	1,2	5-178X	5-1350X
		S	1,2,3	5-213X	5-1330X



Year	Model & Description	Fig.	Location	Spicer Part No.	SPL Part No.
DODGE					
RAM 2500					
2007	LARAMIE, SLT & ST w/2-Joint Shaft w/6.7L Diesel Eng. w/AT w/AAM driveshaft, AAM 1415 Series w/MT w/AAM driveshaft, AAM 1485 Series	A	1,2	5-3207X	
		A	1,2	5-3206X	
	LARAMIE, SLT & ST w/3-Joint Shaft w/5.7L Gas Eng. AAM 1415 Series w/6.7L Diesel Eng. w/AT w/Spicer driveshaft w/MT w/AAM driveshaft AAM 1485 Series	S	1,2,3	5-3207X	
		S	1,2,3	5-160X	SPL36-1X
		S	1,2,3	5-3206X	
	SPORT & TRX4 w/3-Joint Shaft w/5.7L V8 Gas Eng. w/AAM driveshaft, AAM 1415 Series	S	1,2,3	5-3207X	
2008	LARAMIE, SLT & ST w/2-Joint Shaft w/6.7L Diesel Eng. w/AT, w/AAM driveshaft, AAM 1415 Series w/MT, w/AAM driveshaft, AAM 1485 Series	A	1,2	5-3207X	
		A	1,2	5-3206X	
	LARAMIE, SLT & ST w/3-Joint Shaft w/5.7L Gas Eng., w/AAM driveshaft, AAM 1415 Series w/6.7L Diesel Eng. w/AT w/Spicer driveshaft w/MT w/AAM driveshaft AAM 1485 Series	S	1,2,3	5-3207X	
		S	1,2,3	5-160X	SPL36-1X
		S	1,2,3	5-3206X	
	STX w/2-Joint Shaft w/6.7L Diesel Eng. w/AT, w/Spicer driveshaft w/MT, w/AAM driveshaft AAM 1485 Series	A	1,2	5-188X	SPL55X
		A	1,2	5-3206X	
	STX w/3-Joint Shaft w/5.7L Gas Eng., w/AAM driveshaft, AAM 1415 Series w/6.7L Diesel Eng. w/AT w/Spicer driveshaft w/MT w/AAM driveshaft AAM 1485 Series	S	1,2,3	5-3207X	
		S	1,2,3	5-188X	SPL55X
			S	1,2,3	5-3206X

2WD



Important: See Safety Information in General Information Section (J300P-GI)

2WD

Year	Model & Description	Fig.	Location	Spicer Part No.	SPL Part No.	
DODGE						
RAM 2500						
2009	LARAMIE & SLT w/2-Joint shaft w/5.7L Gas & 6.7L Diesel Eng. w/AT w/AAM driveshaft, AAM 1415 Series	A	1,2	5-3207X		
		A	1,2	5-3206X		
	LARAMIE & SLT w/3-Joint shaft w/5.7L Gas & 6.7L Diesel Eng. w/AT w/Spicer driveshaft	S	1,2,3	5-160X	SPL36-1X	
		S	1,2,3	5-3206X		
	ST w/2-Joint shaft w/5.7L Gas, 6.7L & L6 Diesel Eng. w/AT w/AAM driveshaft, AAM 1415 Series	A	1,2	5-3207X		
		A	1,2	5-3206X		
	ST w/3-Joint shaft w/5.7L Gas, 6.7L & L6 Diesel Eng. w/AT w/Spicer driveshaft	S	1,2,3	5-160X	SPL36-1X	
		S	1,2,3	5-3206X		
	STX w/2-Joint shaft w/5.7L Gas & 6.7L Diesel Eng. w/AT	A	1,2	5-188X	SPL55X	
		A	1,2	5-3206X		
	STX w/3-Joint shaft w/5.7L Gas & 6.7L Diesel Eng. w/AT w/Spicer driveshaft	S	1,2,3	5-188X	SPL55X	
		S	1,2,3	5-3206X		
2010	LARAMIE, SLT & ST w/2-Joint shaft w/5.7L Gas & 6.7L Diesel Eng. w/AT w/AAM driveshaft, AAM 1415 Series	A	1,2	5-3207X		
		A	1,2	5-188X	SPL55X	
	LARAMIE, SLT & ST w/3-Joint shaft w/5.7L Gas & 6.7L Diesel Eng. w/AT	S	1,2,3	5-160X	SPL36-1X	
		S	1,2,3	5-188X	SPL55X	
	SXT w/5.7L Gas & 6.7L Diesel Eng. 2-Joint shaft	A	1,2	5-188X	SPL55X	
		S	1,2,3	5-188X	SPL55X	
	RAM 3500					
	2007	LARAMIE, SLT, SPORT, ST w/2-Joint shaft w/5.7L Gas Eng.	A	1,2	5-160X	SPL36-1X
A			1,2	5-188X	SPL55X	
LARAMIE, SLT, SPORT & ST & TRX4 w/2-Joint shaft w/6.7L Diesel Eng. 1.375" cap dia. 1.188" cap dia.		A	1,2	5-160X	SPL36-1X	
		S	1,2,3	5-188X	SPL55X	
LARAMIE, SLT, SPORT, ST w/3-Joint shaft w/5.7L Gas Eng. Cab & Chassis, w/Spicer driveshaft		S	1,2,3	5-188X	SPL55X	
		S	1,2,3	5-3206X		
LARAMIE, SLT, SPORT, ST & TRX4 w/3-Joint shaft 6.7L Diesel Eng., Crew Cab, AAM driveshaft, AAM 1485 Series		S	1,2,3	5-3206X		
		S	1,2,3	5-160X	SPL36-1X	



Year	Model & Description	Fig.	Location	Spicer Part No.	SPL Part No.
DODGE					
RAM 3500					
2008	LARAMIE, SLT, ST & STX w/2-Joint shaft w/5.7L Gas Eng. w/6.7L Diesel Eng. 1.375" cap dia. 1.188" cap dia.	A	1,2	5-160X	SPL36-1X
		A	1,2	5-188X	SPL55X
		A	1,2	5-160X	SPL36-1X
	LARAMIE, SLT, ST & STX w/3-Joint shaft w/5.7L Gas Eng. Cab & Chassis, w/Spicer driveshaft Crew Cab w/AAM driveshaft AAM 1485 Series Std & Ext Cab, w/Spicer driveshaft w/6.7L Diesel Eng. Crew Cab w/AAM driveshaft AAM 1485 Series Std & Ext Cab, w/Spicer driveshaft	S	1,2,3	5-188X	SPL55X
		S	1,2,3	5-3206X	
		S	1,2,3	5-160X	SPL36-1X
		S	1,2,3	5-3206X	
		S	1,2,3	5-160X	SPL36-1X
		S	1,2,3	5-160X	SPL36-1X
2009	LARAMIE, SLT, ST & STX w/2-Joint shaft w/5.7L Gas Eng. w/6.7L Diesel Eng. 1.375" cap dia. 1.188" cap dia.	A	1,2	5-160X	SPL36-1X
		A	1,2	5-188X	SPL55X
		A	1,2	5-160X	SPL36-1X
	LARAMIE w/3-Joint shaft w/5.7L Gas Eng. Cab & Chassis w/Spicer driveshaft Crew Cab w/AAM driveshaft AAM 1485 Series	S	1,2,3	5-188X	SPL55X
		S	1,2,3	5-3206X	
	SLT, ST & STX w/3-Joint shaft w/5.7L Gas Eng. Cab & Chassis w/Spicer driveshaft Crew Cab w/AAM driveshaft AAM 1485 Series Std & Ext Cab w/Spicer driveshaft	S	1,2,3	5-188X	SPL55X
		S	1,2,3	5-3206X	
		S	1,2,3	5-160X	SPL36-1X
	LARAMIE w/3-Joint shaft w/6.7L Diesel Eng. Crew Cab w/AAM driveshaft AAM 1485 Series	S	1,2,3	5-3206X	
		S	1,2,3	5-3206X	
	SLT, ST & STX w/3-Joint shaft w/6.7L Diesel Eng. Crew Cab w/AAM driveshaft AAM 1485 Series Std & Ext Cab w/Spicer driveshaft	S	1,2,3	5-3206X	
		S	1,2,3	5-160X	SPL36-1X
2010	LARAMIE, SLT, ST & STX w/2-Joint shaft w/6.7L Diesel Eng. 1.375" cap dia. 1.188" cap dia.	A	1	5-188X	SPL55X
		A	1	5-160X	SPL36-1X
	LARAMIE, SLT, ST & STX w/3-Joint shaft w/6.7L Diesel Eng. Crew Cab w/AAM driveshaft, AAM 1485 Series Std & Ext Crew Cab w/Spicer driveshaft	S	1,2,3	5-3206X	
		S	1,2,3	5-160X	SPL36-1X
		S	1,2,3	5-160X	SPL36-1X

2WD



Important: See Safety Information in General Information Section (J300P-GI)

Year	Model & Description	Fig.	Location	Spicer Part No.	SPL Part No.
FORD					
E150					
2007-2011		A	1,2	5-178X	5-1350X
E250					
2007-2011		A	1,2	5-178X	5-1350X
E350 SUPER DUTY					
2007-2009	w/2-Joint shaft w/5.4L & 6.8L Eng. w/6.0L Diesel Eng.	A	1,2	5-178X	5-1350X
		A	1,2	5-160X	5-1410X
	w/3-Joint shaft	S	1,2,3	5-160X	5-1410X
FORD					
E350 SUPER DUTY					
2010	2-Joint shaft 5.4L & 6.0L CNG Eng. 5.4L FF & LPG Eng. 6.0L Diesel Eng. 6.8L gas & LPG engines except XL & XLT XL & XLT	A	1,2	5-160X	5-1410X
		A	1,2	5-178X	5-1350X
		A	1,2	5-160X	5-1410X
		A	1,2	5-178X	5-1350X
		A	1,2	5-160X	5-1410X
		S	1,2,3	5-160X	5-1410X
2011	2-Joint shaft 5.4L (CNG, FF, LPG) Eng. (XL, XLT) (except XL,XLT) 5-Speed Trans 4-Spd Trans	A	1,2	5-178X	5-1350X
		A	1,2	5-160X	5-1410X
		A	1,2	5-178X	5-1350X
	3-Joint shaft 5.4L (CNG, FF, LPG) Eng. except XL & XLT 4-Spd Trans except 4-Spd Trans 5.4L (CNG, FF, LPG) Eng. XL & XLT 5.4L (CNG, FF, LPG) Eng. 6.8L (CNG, Gas, LPG) Eng.	S	1,2,3	5-178X	5-1350X
		S	1,2,3	5-160X	5-1410X
		S	1,2,3	5-178X	5-1350X
		S	1,2,3	5-160X	5-1410X
		S	1,2,3	5-160X	5-1410X
E450 SUPER DUTY					
2007-2011		S	1,2,3	5-160X	5-1410X
EXPEDITION					
2007-2011		AB	1,2	5-178X	5-1350X
EXPLORER					
2007-2010		A	1,2	5-213X	5-1330X

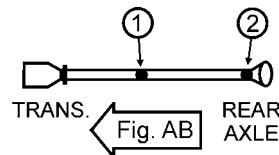
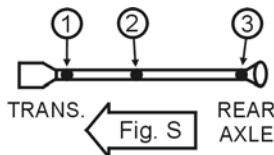
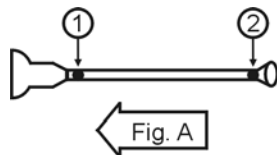

Year	Model & Description	Fig.	Location	Spicer Part No.	SPL Part No.
FORD					
F150					
2007	driveshaft w/staked in u-joints w/outside snap ring	A	1,2	5-3203X	
		S	1,2,3	5-178X	5-1350X
2008-2010		A	1,2	5-178X	5-1350X
		S	1,2,3	5-178X	5-1350X
2011		A	1,2	5-160X	5-1410X
F250					
2007-2011		A	1,2	5-160X	5-1410X
		S	1,2,3	5-160X	5-1410X
F350					
2007-2011		A	1,2	5-160X	5-1410X
		S	1,2,3	5-160X	5-1410X
F450					
2007-2009		S	1,2,3	5-188X	SPL55X
		AZ	1,2,3,4	5-188X	SPL55X
2010		S	1,2,3	5-188X	SPL55X
2011		S	1,2,3	5-188X	SPL55X
		AZ	1,2,3,4	5-188X	SPL55X
F550					
2007-2011		S	1,2,3	5-188X	SPL55X
		AZ	1,2,3,4	5-188X	SPL55X
RANGER					
2007-2011		A	1,2	5-213X	5-1330X
GMC					
CANYON					
2007-2011		A	1,2	5-213X	5-1330X
		S	1,2,3	5-213X	5-1330X
ENVOY					
2007		A	1,2	5-3147X	5-795X
2008	w/4.2L Gas Eng.	A	1,2	5-3147X	5-795X
	w/5.3L Gas Eng.	A	1,2	5-178X	5-1350X
2009		A	1,2	5-178X	5-1350X
SAVANA 1500					
2007-2008	alum. driveshaft	A	1,2		5-3615X
2009-2011		A	1,2	5-178X	5-1350X

2WD

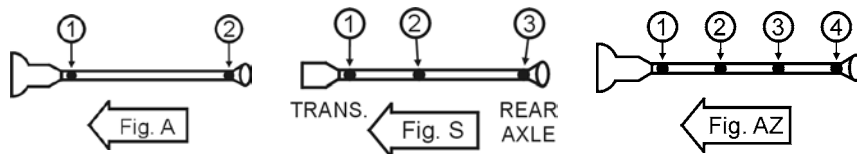

Important: See Safety Information in General Information Section (J300P-GI)

Year	Model & Description	Fig.	Location	Spicer Part No.	SPL Part No.
GMC					
SAVANA 2500					
2007	alum. shaft	A	1,2		5-3615X
		S	1,2,3	5-178X	5-1350X
2008-2010		A	1,2	5-178X	5-1350X
		S	1,2,3	5-178X	5-1350X
2011	w/Spicer driveshaft w/FF Eng.	A	1,2	5-160X	5-1410X
	w/AAM driveshaft, AAM 1485 Series w/6.6L Diesel Eng.	S	1,2,3	5-3206X	
SAVANA 3500					
2007	2-Joint shaft 4.8L Gas Eng. 135" WB 139" WB Dual Rear Wheels Single Rear Wheels	A	1,2		5-3615X
		A	1,2	5-160X	5-1410X
		A	1,2		5-3615X
	6.0L Gas Eng. 135" WB LS & LT except LS & LT 139" WB Single Rear Wheels LS & LT Dual Rear Wheels	A	1,2	5-178X	5-1350X
		A	1,2		5-3615X
		A	1,2	5-178X	5-1350X
	6.6L Diesel Eng. 135" WB 139" WB Dual Rear Wheels Single Rear Wheels	A	1,2	5-160X	5-1410X
		A	1,2		5-3615X
		A	1,2	5-160X	5-1410X
		A	1,2		5-3615X
	3-Joint shaft 4.8L & 6.0L Gas Eng. 155" & 157" WB 6.6L Diesel Eng. 155" & 157" WB	S	1,2,3	5-178X	5-1350X
		S	1,2,3	5-178X	5-1350X
	2008	2-Joint shaft 4.8L Gas Eng. 135" & 139" WB 6.0L Gas & 6.6L Diesel Eng. 135" WB 139" WB Single Rear Wheels Dual rear wheels	A	1,2	5-178X
A			1,2	5-178X	5-1350X
A			1,2	5-178X	5-1350X
A			1,2	5-160X	5-1410X
3-Joint shaft 155" WB 159" WB		S	1,2,3	5-178X	5-1350X
		S	1	5-178X	5-1350X
		S	2,3	5-160X	5-1410X

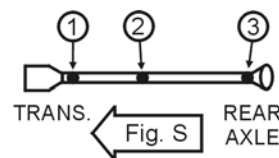
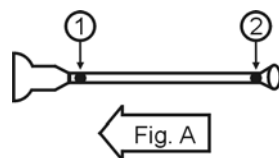

Year	Model & Description	Fig.	Location	Spicer Part No.	SPL Part No.
GMC					
SAVANA 3500					
2009	2-Joint shaft 135" WB 139" WB Single Rear Wheels Dual rear wheels	A	1,2	5-178X	5-1350X
		A	1,2	5-178X	5-1350X
		A	1,2	5-160X	5-1410X
	3-Joint shaft 155" WB 159" WB	S	1,2,3	5-178X	5-1350X
		S	1	5-178X	5-1350X
		S	2,3	5-160X	5-1410X
2010	2-Joint shaft 4.8L FF & 6.6L Diesel Eng. 135" WB 139" WB Dual Rear Wheels Single Rear Wheels 6.0L FF Eng. 135" WB 139" WB Dual Rear Wheels w/AAM driveshaft, AAM 1485 Series 139" WB Single Rear Wheels w/Spicer driveshaft	A	1,2	5-178X	5-1350X
		A	1,2	5-160X	5-1410X
		A	1,2	5-178X	5-1350X
		A	1,2	5-160X	5-1410X
		A	1,2	5-3206X	
		A	1,2	5-160X	5-1410X
	3-Joint shaft 4.8L FF & 6.6L Diesel Eng. 155" WB 159" WB 6.0L FF Eng. 155" WB 159" WB w/Spicer driveshaft w/AAM driveshaft, AAM 1485 Series	S	1,2,3	5-178X	5-1350X
		S	1,2,3	5-178X	5-1350X
		S	1,2,3	5-160X	5-1410X
		S	1,2,3	5-160X	5-1410X
		S	1,2,3	5-160X	5-1410X
		S	1,2,3	5-160X	5-1410X
		S	1,2,3	5-3206X	
		S	1,2,3	5-3206X	
2010	2-Joint shaft 4.8L FF & 6.6L Diesel Eng. 135" WB w/AAM driveshaft, AAM 1485 Series 139" WB w/Spicer driveshaft, Dual Rear Wheels w/AAM driveshaft, AAM 1485 Series Single Rear Wheels 6.0L FF Eng. 135" WB 139" WB w/AAM driveshaft, AAM 1485 Series Dual Rear Wheels w/Spicer driveshaft Single Rear Wheels	A	1,2	5-3206X	
		A	1,2	5-160X	5-1410X
		A	1,2	5-3206X	
		A	1,2	5-160X	5-1410X
		A	1,2	5-3206X	
		A	1,2	5-160X	5-1410X
	3-Joint shaft 4.8L FF & 6.6L Diesel Eng., 155" WB w/AAM driveshaft, AAM 1485 Series 4.8L FF Eng. 159" WB, w/AAM driveshaft, AAM 1485 Series 6.0L FF Eng. 155" WB 159" WB w/Spicer driveshaft w/AAM driveshaft, AAM 1485 Series	S	1,2,3	5-3206X	
		S	1,2,3	5-3206X	
		S	1,2,3	5-160X	5-1410X
		S	1,2,3	5-160X	5-1410X
		S	1,2,3	5-160X	5-1410X
		S	1,2,3	5-3206X	

2WD



Important: See Safety Information in General Information Section (J300P-GI)

2WD

Year	Model & Description	Fig.	Location	Spicer Part No.	SPL Part No.
GMC					
SIERRA 1500					
2007	2-Joint shaft				
	CLASSIC SL, SLE, SLT & WT				
	119" & 134" WB	A	1,2	5-3147X	5-795X
	133" WB	A	1	5-213X	5-1330X
		A	2	5-212X	5-7436X
	SLE, SLT & WT Exc. 157.5" WB	A	1,2	5-178X	5-1350X
	3-Joint shaft				
	CLASSIC SL 143.5" WB w/AT	S	1,2,3	5-3147X	5-795X
	w/MT	S	1,2	5-213X	5-1330X
		S	3	5-212X	5-793X
	157.5" WB	S	1,2,3	5-3147X	5-795X
	CLASSIC SLE 4.8L & 5.3L Gas & 6.3L FF Eng.	S	1,2,3	5-3147X	5-795X
	6.0L Gas Eng. 143.5" WB	S	1,2,3	5-178X	5-1350X
	157.5" WB	S	1,2,3	5-3147X	5-795X
	CLASSIC SLT				
	5.3L Gas Eng. 143.5" & 157.5" WB	S	1,2,3	5-3147X	5-795X
	6.0L Gas Eng. 143.5" WB	S	1,2,3	5-178X	5-1350X
	157.5" WB	S	1,2,3	5-3147X	5-795X
	CLASSIC WT 143.5" WB w/AT	S	1,2,3	5-3147X	5-795X
	w/MT	S	1,2	5-213X	5-1330X
	S	3	5-212X	5-793X	
157.5" WB	S	1,2,3	5-3147X	5-795X	
HD CLASSIC SLE	S	1,2,3		5-3615X	
SLE & SLT & WT	S	1,2,3	5-178X	5-1350X	
2008-2011		A	1,2	5-178X	5-1350X
		S	1,2,3	5-178X	5-1350X
SIERRA 2500 HD					
2007	3-Joint shaft				
	CLASSIC SL, SLE, SLT & WT	S	1,2,3	5-160X	5-1410X
	SLE, SLT & WT				
	w/Spicer driveshaft				
	6.0L Gas Eng. 133" WB	S	1,2,3	5-160X	5-1410X
	Exc. 133" WB	S	1,2,3	5-160X	5-1410X
	w/AAM driveshaft, AAM 1485 Series				
6.0L Gas Eng.	S	1,2,3	5-3206X		
w/Spicer driveshaft					
6.6L Diesel Eng.	S	1,2,3	5-160X	5-1410X	
w/AAM driveshaft, AAM 1485 Series					
6.6L Diesel Eng.	S	2,3	5-3206X		

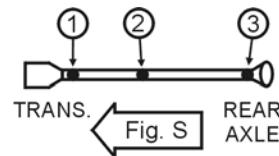
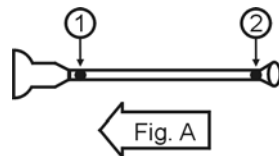

Year	Model & Description	Fig.	Location	Spicer Part No.	SPL Part No.
GMC					
SIERRA 2500 HD					
2008-2011	3-Joint shaft SLE, SLT & WT w/AAM driveshaft, AAM 1485 Series 6.0L Gas Eng. Exc. 133" WB	S	1,2,3	5-3206X	
		S	1,2,3	5-160X	5-1410X
		S	1,2,3	5-3206X	
SIERRA 3500					
2007-2011	HD SLE, SLT & WT w/Spicer driveshaft w/AAM driveshaft AAM 1485 Series	S	1,2,3	5-160X	5-1410X
		S	1,2,3	5-3206X	
SIERRA DENALI					
2007-2009		A	1,2	5-178X	5-1350X
2010	Exc. 157.5" WB w/157.5" WB	A	1,2	5-178X	5-1350X
		S	1,2,3	5-178X	5-1350X
YUKON					
2007	w/4.8L & 5.3L Gas & 5.3L FF Eng. w/6.0L Gas Eng.	A	1,2	5-3147X	5-795X
		A	1,2	5-178X	5-1350X
2008	HYBRID w/4.8L & 5.3L Gas & 5.3L FF Eng. w/6.0L Gas Eng.	A	1,2	5-178X	5-1350X
		A	1,2	5-3147X	5-795X
		A	1,2	5-160X	5-1410X
2009	DENALI, SLE, SLT & XL 1500 DENALI, SLE & SLT HYBRID XL 2500 SLE & SLT	A	1,2	5-178X	5-1350X
		A	1,2	5-178X	5-1350X
		A	1,2	5-160X	5-1410X
2010-2011	DENALI, SLE, SLT & XL 1500 DENALI, SLE & SLT HYBRID & DENALI HYBRID XL 2500 SLE & SLT	A	1,2	5-178X	5-1350X
		A	1,2	5-178X	5-1350X
		A	1,2	5-160X	5-1410X
ISUZU					
ASCENDER					
2007-2008		A	1,2	5-3147X	5-795X
I-290					
2007-2008	2-Joint shaft	A	1	5-213X	5-1330X
		A	2	5-212X	5-793X
	3-Joint shaft	S	1,2	5-213X	5-1330X
		S	3	5-212X	5-793X
JEEP					
LIBERTY					
2007		A	1,2	5-153X	5-1310X

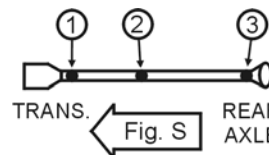
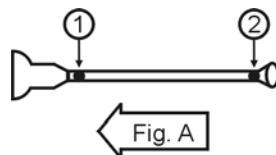

Year	Model & Description	Fig.	Location	Spicer Part No.	SPL Part No.
LINCOLN					
MARK LT					
2007	driveshaft w/staked in u-joints 3-Joint shaft	A	1,2	5-3203X	
		S	1,2,3	5-178X	5-1350X
2008		A	1,2	5-178X	5-1350X
		S	1,2,3	5-178X	5-1350X
LINCOLN					
NAVIGATOR					
2007-2008	w/5.4L Gas Eng.	AB	1,2	5-178X	5-1350X
2009-2011	w/5.4L FF Eng.	AB	1,2	5-178X	5-1350X
MAZDA					
B2300					
2007-2009	Cab Plus	A	1,2	5-213X	5-1330X
B3000					
2007	Cab Plus Std Cab	A	1,2	5-213X	5-1330X
		A	1,2	5-1204X	5-7438X
MAZDA					
B4000					
2008	Cab Plus Std Cab	A	1,2	5-213X	5-1330X
		A	1,2	5-1204X	5-7438X
MERCURY					
MARINER					
2010-2011		AT	1,2	5-153X	5-1310X
MOUNTAINEER					
2007-2010		A	1,2	5-213X	5-1330X
MITSUBISHI					
RAIDER					
2007-2009		A	1,2	5-213X	5-1330X
		S	1,2,3	5-213X	5-1330X
NISSAN					
ARMADA					
2007-2010		A	1,2	5-178X	5-1350X
FRONTIER					
2007-2010	w/2.5L Gas Eng.	S	1,2,3	5-153X	5-1310X
	w/4.0L Gas Eng.	S	1,2,3	5-213X	5-1330X
PATHFINDER					
2007-2008		A	1,2	5-213X	5-1330X
2009-2010		A	1,2	5-178X	5-1350X

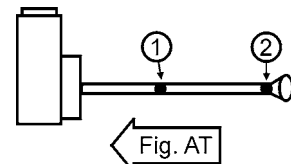
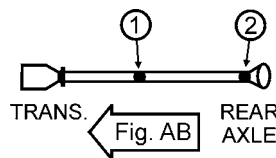
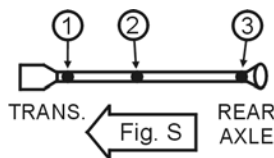
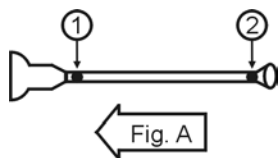

Year	Model & Description	Fig.	Location	Spicer Part No.	SPL Part No.
NISSAN					
TITAN					
2007		S	1,2,3	5-160X	5-1410X
2008	To 04/08	S	1,2,3	5-160X	5-1410X
XTERRA					
2007-2010		A	1,2	5-213X	5-1330X
SUZUKI					
EQUATOR					
2009-2010		S	1,2,3	5-153X	5-1310X
TOYOTA					
4RUNNER					
2007-2011		A	1,2	5-1510X	
FJ CRUISER					
2009-2010		A	1,2	5-1510X	
SEQUOIA					
2008-2011		A	1,2		5009485
TACOMA					
2007-2011	Extra Cab	S	1,2,3	5-213X	5-1330X
	Std Cab	A	1,2	5-213X	5-1330X
TUNDRA					
2007-2011		A	1,2		5009485
		S	1,2,3		5009485

2WD

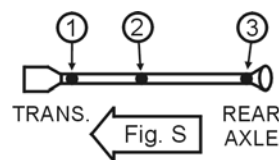
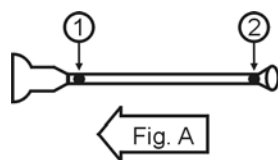

Important: See Safety Information in General Information Section (J300P-GI)

Year	Model & Description	Fig.	Location	Spicer Part No.	SPL Part No.
AM GENERAL/HUMMER					
H2					
2007-2009		L	2,3	5-3147X	5-795X
		L	4,5	5-178X	5-1350X
H3					
2007-2010		L	2	5-350X	
		L	4,5	5-178X	5-1350X
BUICK					
RAINIER					
2007		L	2	5-350X	
		L	4,5	5-178X	5-1350X
CADILLAC					
ESCALADE					
2007-2008		L	2,3,4	5-3147X	5-795X
2009-2011		L	2,3	5-3147X	5-795X
		L	4,5	5-178X	5-1350X
CHEVROLET					
AVALANCHE					
2007-2008	w/5.3L FF Eng.	L	2,3,4	5-3147X	5-795X
	w/6.0L Gas Eng.	L	2,3	5-3147X	5-795X
		L	4,5	5-178X	5-1350X
2009-2011	w/5.3L FF & 6.0L Eng.	L	2,3	5-3147X	5-795X
		L	4,5	5-178X	5-1350X
COLORADO PICK-UP					
2007-2011	w/Spicer driveshaft w/outside snap rings w/inside & outside snap rings	L	2	5-153X	5-1310X
		L	4	5-213X	5-1330X
		L	5	5-212X	5-7436X
G-10 SERIES, G1500 SERIES AND EXPRESS					
2007-2011	EXPRESS 1500	L	2,3,4	5-3147X	5-795X

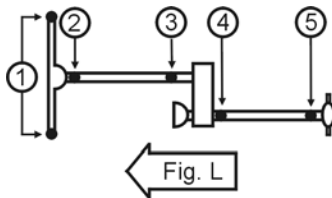

Year	Model & Description	Fig.	Location	Spicer Part No.	SPL Part No.
CHEVROLET					
SILVERADO 1500					
2007	CLASSIC HYBRID 5.3L Gas & Elec. Eng. 119" & 133" WB	L	2,3	5-3147X	5-795X
		L	4,5	5-178X	5-1350X
	CLASSIC LS, LT & WT All 119" & 133" WB 134" WB w/143.5" WB w/Drive Ratio 3.42 Exc. Drive Ratio 3.42	L	2,3	5-3147X	5-795X
		L	4,5	5-178X	5-1350X
		L	4		5-3615X
		L	5	5-178X	5-1350X
		L	4		5-3615X
		L	5	5-178X	5-1350X
	LS, LT, LTZ & WT	L	2,3	5-3147X	5-795X
		L	4,5	5-178X	5-1350X
	CLASSIC LS, LT & WT 4.3L Gas Eng. 157.5" WB	N	2,3	5-3147X	5-795X
		N	4,5,6		5-3615X
	HD CLASSIC LT 6.0L Gas Eng.	N	2,3	5-3147X	5-795X
		N	4,5,6		5-3615X
2008-2009		L	2,3,4	5-3147X	5-795X
		L	5,6	5-178X	5-1350X
2010-2011		L	3,4	5-3147X	5-795X
		L	5,6	5-178X	5-1350X

4WD

SILVERADO 2500HD

2007	HD CLASSIC LS, LT & WT w/6.0L Gas Eng. 133" & 143.5" WB 153" & 157.5" WBw/AT w/6.6L Diesel & 8.1L Gas Eng. 133" & 143.5" WB 153" & 157.5" WB	L	2,3	5-3147X	5-795X
		L	4,5	5-160X	5-1410X
		L	4,5	5-160X	5-1410X
		L	2,3	5-3147X	5-795X
		L	4,5		SPL55-2X
		L	4,5	5-160X	5-1410X
	HD LT	L	2,3	5-3147X	5-795X
		L	4,5	5-160X	5-1410X
	HD CLASSIC LS, LT & WT w/6.0L Gas Eng. 153" & 157.5" WB w/MT 167" WB w/6.6L Diesel & 8.1L Gas Eng. 167" WB	N	2,3	5-3147X	5-795X
		N	4,5,6	5-160X	5-1410X
		N	4,5,6	5-160X	5-1410X
		N	2,3	5-3147X	5-795X
		N	4,5,6	5-160X	5-1410X
		N	2,3	5-3147X	5-795X
HD LT	N	2,3	5-3147X	5-795X	
	N	4,5,6	5-160X	5-1410X	

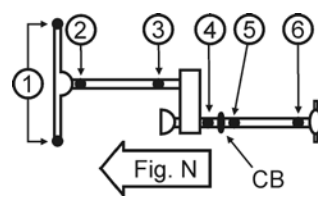
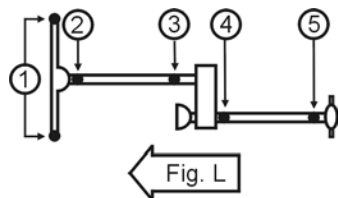

Important: See Safety Information in General Information Section (J300P-GI)

Year	Model & Description	Fig.	Location	Spicer Part No.	SPL Part No.
CHEVROLET					
SILVERADO 2500HD					
2008-2010	LT, LTZ & WT w/6.0L Gas Eng. w/6.6L Diesel Eng. AAM 1485 Series	L	2,3	5-3147X	5-795X
		L	4,5	5-160X	5-1410X
		L	4,5	5-3206X	
	LT, LTZ & WT w/6.0L Gas Eng. w/6.6L Diesel Eng. AAM 1485 Series	N	2,3	5-3147X	5-795X
		N	5,6	5-160X	5-1410X
		N	5,6	5-3206X	
2011	LT, LTZ & WT w/6.0L FF Eng. w/6.6L Diesel Eng. 133.6" & 158.1" WB AAM 1485 Series	L	2	5-3147X	5-795X
		L	4,5	5-160X	5-1410X
		L	4,5	5-3206X	
	w/6.0L FF Eng. LT, LTZ & WT w/6.0L FF Eng. w/6.6L Diesel Eng. Exc. 133.6" & 158.1" WB AAM 1485 Series	N	2,3	5-3147X	5-795X
		N	4,5,6	5-160X	5-1410X
		N	4,5,6	5-3206X	
SILVERADO 3500					
2007	CLASSIC LS, LT & WT w/6.0L Gas Eng. 133" & 137" WB 157.5" WB, w/AT w/6.6L Diesel Eng. 157.5" WB 161.5" WB 133" WB w/8.1L Gas Eng. 157.5" WB 161.5" WB 133" WB	L	2,3	5-3147X	5-795X
		L	4,5	5-160X	5-1410X
		L	4	5-160X	5-1410X
		L	4,5	5-160X	5-1410X
		L	4,5	5-160X	5-1410X
		L	4,5	5-188X	SPL55-2X
		L	4,5	5-160X	5-1410X
		L	4,5	5-160X	5-1410X
		L	4,5	5-188X	SPL55-2X
		L	4,5	5-3206X	
	LT, LTZ & WT 133" & 157.5" WB AAM 1485 Series	N	4,5,6	5-160X	5-1410X
		N	4,5,6	5-160X	5-1410X
		N	4,5,6	5-188X	SPL55-2X
		N	4,5,6	5-160X	5-1410X
		N	4,5,6	5-188X	SPL55-2X
		N	4,5,6	5-188X	SPL55-2X
		N	4,5,6	5-160X	5-1410X
		N	4,5,6	5-188X	SPL55-2X
	CLASSIC LS, LT & WT w/6.0L Gas Eng. 157.5" WB, w/MT 161.5" & 167" WB w/6.6L Diesel Eng. 161.5" WB 167" WB 185.5" WB w/8.1L Gas Eng. 161.5" WB 167" WB 185.5" WB	N	5,6	5-3206X	
		N	5,6	5-3206X	
	LT & WT w/6.0L Gas & 6.6L Diesel Eng. 167" WB AAM 1485 Series	N	5,6	5-3206X	
LTZ w/6.0L Gas & 6.6L Diesel Eng. 133" & 157.5" & 167" WB AAM 1485 Series	N	5,6	5-3206X		

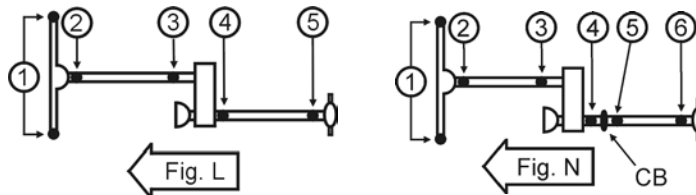

4WD

Year	Model & Description	Fig.	Location	Spicer Part No.	SPL Part No.
CHEVROLET					
SILVERADO 3500					
2008-2010	AAM 1485 Series	L	2,3	5-3147X	5-795X
		L	4,5	5-3206X	
	AAM 1485 Series	N	2,3	5-3147X	5-795X
		N	4,5,6	5-3206X	
SUBURBAN 1500					
2007	LS, LT, Z71 & LTZ	L	2,3,4,5	5-3147X	5-795X
2008	LS, LT & LTZ	L	2,3,4,5	5-3147X	5-795X
2009-2011	LS, LT & LTZ	L	2,3	5-3147X	5-795X
		L	4,5	5-178X	5-1350X
SUBURBAN 2500					
2007	LS, LT & LTZ	L	2,3	5-3147X	5-795X
		L	4,5	5-178X	5-1350X
2008-2011	LS & LT	L	2,3	5-3147X	5-795X
		L	4,5	5-160X	5-1410X
TAHOE					
2008-2011		L	2,3	5-3147X	5-795X
		L	4,5	5-178X	5-1350X
TRAILBLAZER					
2007	w/4.2L & 5.3L Gas Eng. w/6.0L Gas Eng.	L	2	5-350X	
		L	4,5	5-3147X	5-795X
		L	4,5	5-178X	5-1350X
2008	w/4.2L & 5.3L Gas Eng. w/6.0L Gas Eng.	L	2	5-350X	
		L	4,5	5-3147X	5-795X
		L	4,5	5-178X	5-1350X
2009	w/4.2L Gas Eng. w/6.0L Gas Eng.	L	2	5-350X	
		L	4,5	5-3147X	5-795X
		L	4,5	5-178X	5-1350X
CHRYSLER					
ASPEN LIMITED					
2007-2009		L	4,5	5-3147X	5-795X
DODGE					
DAKOTA					
2007-2009		L	2	5-153X	5-1310X
		L	4,5	5-213X	5-1330X
2010-2011	BIG HORN, LARAMIE, ST & TRX4	L	2	5-153X	5-1310X
		L	4,5	5-213X	5-1330X

4WD

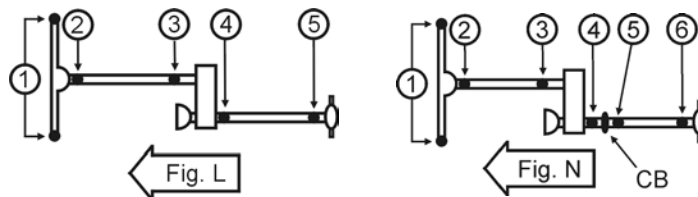

Important: See Safety Information in General Information Section (J300P-GI)

Year	Model & Description	Fig.	Location	Spicer Part No.	SPL Part No.
DODGE					
DURANGO					
2007-2009		L	5,6	5-3147X	5-795X
RAM 1500					
2011		AU	1	5-213X	5-1330X
		AU	2,3,4	5-213X	5-1330X
		L	2	5-213X	5-1330X
		L	4,5	5-178X	5-1350X
RAM 2500					
2007-2008	5.7L Gas Eng. AAM 1355 Series AAM 1415 Series	AY	2	5-3147X	5-795X
		AY	3,4	5-3208X	
		AY	5,6,7	5-3207X	
	6.7L Diesel Eng.	AY	1		5006813
		AY	2	5-3147X	5-795X
	AAM 1355 Series w/AT	AY	3,4	5-3208X	
		AY	5,6,7	5-160X	SPL36-1X
	w/MT AAM 1485 Series 6.7L Diesel Eng.	AY	5,6,7	5-3206X	
		BA	1		5006813
	AAM 1355 Series w/AT AAM 1415 Series	BA	2	5-3147X	5-795X
		BA	3,4	5-3208X	
	w/MT AAM 1485 Series	BA	5,6	5-3207X	
		BA	5,6	5-3206X	
	2009	5.7L Gas Eng. AAM 1355 Series Except Power Wagon w/AT w/MT AAM 1485 Series	AY	1	
AY			2	5-3147X	5-795X
AY			3,4	5-3208X	
Power Wagon		AY	5,6,7	5-160X	SPL36-1X
		AY	5,6,7	5-3206X	
6.7L Diesel Eng.		AY	5,6,7	5-160X	SPL36-1X
		AY	1		5006813
AAM 1355 Series w/AT		AY	2	5-3147X	5-795X
		AY	3,4	5-3208X	
w/MT AAM 1485 Series		AY	5,6,7	5-160X	SPL36-1X
		AY	5,6,7	5-3206X	
5.7L Gas Eng. AAM 1355 Series Except Power Wagon w/AT AAM 1415 Series w/MT AAM 1485 Series Power Wagon AAM 1415 Series		BA	1		5006813
		BA	2	5-3147X	5-795X
		BA	3,4	5-3208X	
	BA	5,6	5-3207X		
	BA	5,6	5-3206X		
	BA	5,6	5-3207X		

4WD

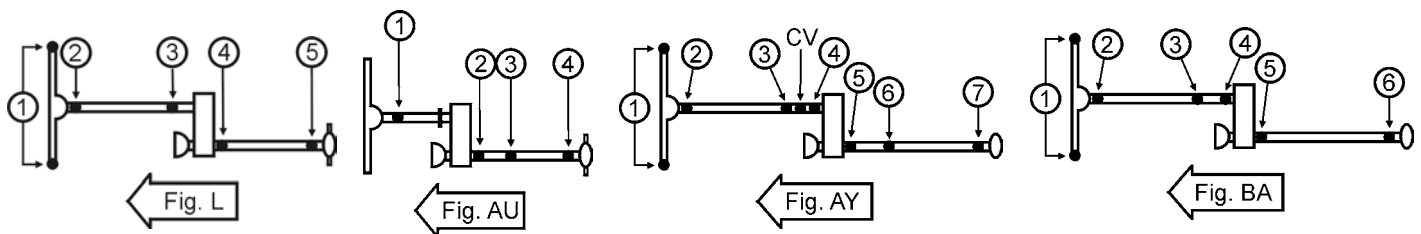

Year	Model & Description	Fig.	Location	Spicer Part No.	SPL Part No.
DODGE					
RAM 2500					
2009	6.7L Diesel Eng. AAM 1355 Series w/AT AAM 1415 Series w/MT AAM 1485 Series	BA	1		5006813
		BA	2	5-3147X	5-795X
		BA	3,4	5-3208X	
		BA	5,6	5-3207X	
		BA	5,6	5-3206X	
2010	5.7L Gas Eng. AAM 1355 Series Except Power Wagon w/AT w/MT Power Wagon	AY	2	5-3147X	5-795X
		AY	3,4	5-3208X	
		AY	5,6,7	5-160X	SPL36-1X
	6.7L Diesel Eng. AAM 1355 Series w/AT w/Spicer driveshaft w/MT w/AAM driveshaft, AAM 1485 Series	AY	5,6,7	5-188X	SPL55X
		AY	5,6,7	5-160X	SPL36-1X
		AY	2	5-3147X	5-795X
		AY	3,4	5-3208X	
	5.7L Gas Eng. AAM 1355 Series Except Power Wagon w/AT, w/AAM driveshaft, AAM 1415 Series w/MT, w/Spicer driveshaft Power Wagon w/AAM driveshaft, AAM 1415 Series	AY	5,6,7	5-3206X	
		BA	2	5-3147X	5-795X
		BA	3,4	5-3208X	
		BA	5,6	5-3207X	
		BA	5,6	5-188X	SPL55X
	6.7L Diesel Eng. AAM 1355 Series w/AT w/AAM driveshaft, AAM 1415 Series w/MT w/Spicer driveshaft	BA	5,6	5-3207X	
		BA	1		5006813
		BA	2	5-3147X	5-795X
		BA	3,4	5-3208X	
		BA	5,6	5-3207X	
BA		5,6	5-188X	SPL55	

4WD

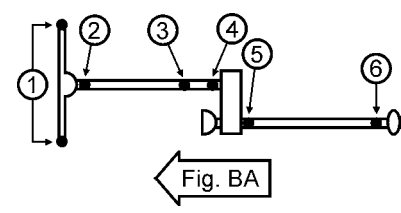
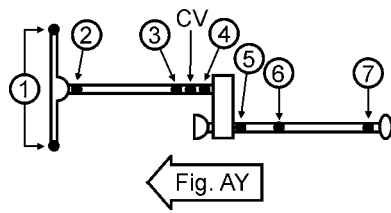

Year	Model & Description	Fig.	Location	Spicer Part No.	SPL Part No.	
DODGE						
RAM 3500 PICK-UP						
2007	LARAMIE, SLT, SPORT & ST Crew Cab w/AAM driveshaft AAM 1485 Series Extended Cab, Std Cab w/Spicer driveshaft 5.7L Diesel Eng.	AY	1		5006813	
		AY	2,3,4	5-178X	5-1350X	
		AY	5,6,7	5-3206X		
		AY	5,6,7	5-160X	SPL36-1X	
		BA	1		5006813	
		BA	5,6	5-160X	SPL36-1X	
		BA	2,3,4	5-178X	5-1350X	
		BA	5,6	5-3207X		
		BA	5,6	5-160X	SPL36-1X	
		BA	1		5006813	
		BA	5,6	5-160X	SPL36-1X	
		BA	2,3,4	5-178X	5-1350X	
	Crew Cab w/AAM driveshaft AAM 1415 Series Exc.Crew Cab w/Spicer driveshaft 6.7L Diesel Eng.	BA	5,6	5-3207X		
		BA	5,6	5-188X	SPL55X	
		BA	5,6	5-3206X		
		TRX4 Crew Cab w/AAM driveshaft AAM 1485 Series Extended Cab, Std Cab w/Spicer driveshaft L6 Diesel Eng.	AY	1		5006813
			AY	2,3,4	5-178X	5-1350X
			AY	5,6,7	5-3206X	
			AY	5,6,7	5-160X	SPL36-1X
			BA	1		5006813
			BA	5,6	5-160X	SPL36-1X
			BA	2,3,4	5-178X	5-1350X
			BA	5,6	5-3207X	
			BA	5,6	5-188X	SPL55X
BA	5,6		5-3206X			
Crew Cab w/AAM driveshaft AAM 1415 Series Exc.Crew Cab w/Spicer driveshaft, w/AT w/AAM driveshaft, w/MT AAM 1485 Series	BA		5,6	5-3206X		

4WD

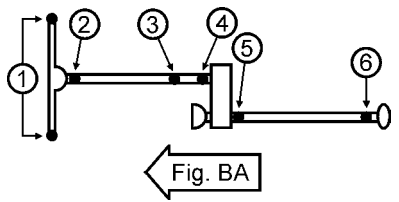
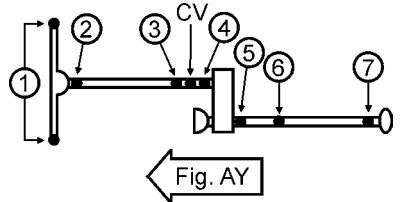

Year	Model & Description	Fig.	Location	Spicer Part No.	SPL Part No.		
DODGE							
RAM 3500 PICK-UP							
2008	LARAMIE, SLT, SPORT & ST Crew Cab w/AAM driveshaft, AAM 1485 Series Extended Crew Cab, Std Cab w/Spicer driveshaft Cab & Chassis Exc. Cab & Chassis 5.7L Gas Eng. Crew Cab w/AAM driveshaft, AAM 1415 Series Exc.Crew Cab 6.7L Diesel Eng. Crew Cab w/AAM driveshaft, AAM 1415 Series Exc.Crew Cab w/AT w/MT w/AAM driveshaft AAM 1485 Series	AY	1		5006813		
		AY	2,3,4	5-178X	5-1350X		
		AY	5,6,7	5-3206X			
		AY	5,6	5-160X	SPL36-1X		
		BA	1		5006813		
		BA	4	5-178X	5-1350X		
		BA	5,6	5-160X	SPL36-1X		
		BA	2,3,4	5-178X	5-1350X		
		BA	2,3	5-178X	5-1350X		
		BA	5	5-3207X			
		BA	6	5-160X	SPL36-1X		
		BA	5	5-3207X			
		BA	6	5-188X	SPL55X		
		2009	LARAMIE, SLT, SPORT & ST Crew Cab w/AAM driveshaft, AAM 1485 Series Extended Crew Cab, Std Cab w/Spicer driveshaft 5.7L Gas Eng. Crew Cab w/AAM driveshaft, AAM 1415 Series Exc.Crew Cab 6.7L Diesel Eng. Crew Cab w/AAM driveshaft, AAM 1415 Series Exc.Crew Cab w/AT w/MT w/AAM driveshaft AAM 1485 Series	AY	1		5006813
AY	2,3,4			5-178X	5-1350X		
AY	5,6,7			5-3206X			
AY	5,6,7			5-160X	SPL36-1X		
BA	1				5006813		
BA	2,3,4			5-178X	5-1350X		
BA	5,6			5-160X	SPL36-1X		
BA	5			5-3207X			
BA	6			5-160X	SPL36-1X		
BA	5			5-3207X			
BA	6			5-188X	SPL55X		
BA	6			5-3206X			
	LARAMIE Extended Crew Cab			S	1,2,3	5-160X	SPL36-1X

4WD

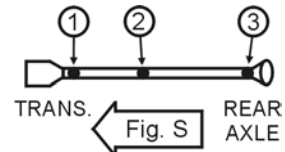
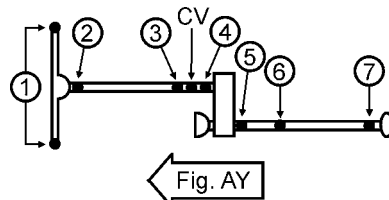
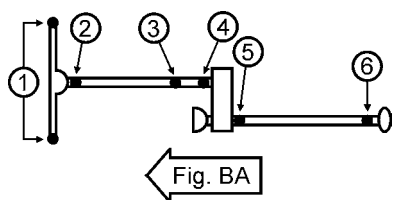

Important: See Safety Information in General Information Section (J300P-GI)

Year	Model & Description	Fig.	Location	Spicer Part No.	SPL Part No.
DODGE					
RAM 3500 PICK-UP					
2010	LARAMIE, SLT, SPORT & ST Crew Cab w/AAM driveshaft, AAM 1485 Series Extended Crew Cab, Std Cab	AY	2,3,4	5-178X	5-1350X
		AY	5,6,7	5-3206X	
		AY	5,6,7	5-160X	SPL36-1X
		BA	2,3,4	5-178X	5-1350X
	BA	5,6	5-160X	SPL36-1X	
	Crew Cab w/AAM driveshaft, AAM 1415 Series Exc.Crew Cab w/AT w/MT w/AAM driveshaft AAM 1485 Series	BA	5	5-3207X	
		BA	6	5-188X	SPL55X
LARAMIE Extended Crew Cab	BA	6	5-3206X		
		S	1,2	5-160X	SPL36-1X

4WD

FORD ESCAPE

2010-2011	2-Joint shaft	AT	1,2	5-153X	5-1310X
-----------	---------------	----	-----	--------	---------

EXPEDITION

2007-2011		L	2,3	5-178X	5-1350X
-----------	--	---	-----	--------	---------

EXPLORER

2007-2008	SPORT TRAC LIMITED & SPORT TRAC XLT EDDIE BAUER, LIMITED, XLT	AU	1	5-153X	5-1310X
		L	2	5-153X	5-1310X
		L	4,5	5-178X	5-1350X
2009-2010		L	2	5-153X	5-1310X
		L	4,5	5-178X	5-1350X

F150

2007	w/Staked U-Joints	L	2,3	5-3203X	
	w/Outside snap rings	L	4,5	5-178X	5-1350X
	w/Staked U-Joints	L	4,5	5-3203X	
	w/Staked U-Joints	N	2,3	5-3203X	
		N	4,5,6	5-178X	5-1350X
2008		N	2,3,4,5,6	5-178X	5-1350X
2009-2011		L	2,3,4,5	5-178X	5-1350X
		N	2,3,4,5,6	5-178X	5-1350X

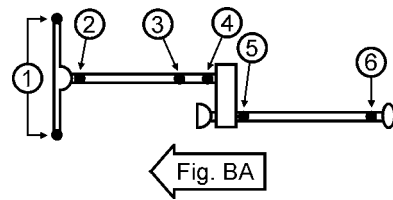
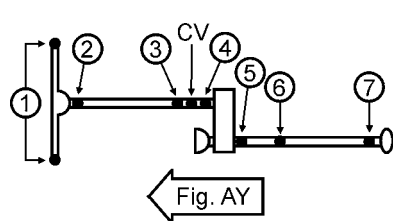
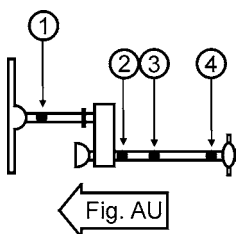
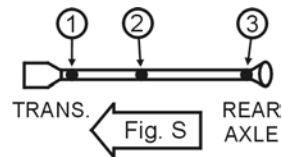
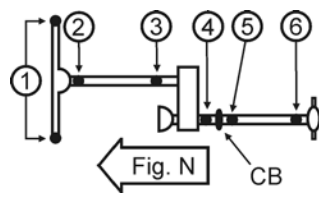
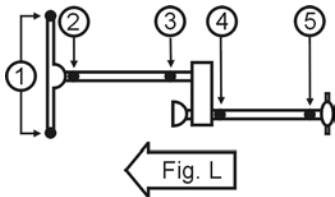

Year	Model & Description	Fig.	Location	Spicer Part No.	SPL Part No.	
FORD						
F250						
2007-2008		AE	1		SPL55-4X	
		AE	2	5-178X	5-1350X	
		AE	5,6,7	5-160X	5-1410X	
		BA	1		SPL55-4X	
		BA	2	5-178X	5-1350X	
		BA	5,6	5-160X	5-1410X	
2009-2011		AE	1		SPL55-4X	
		AE	2,5,6,7	5-160X	5-1410X	
		BA	1		SPL55-4X	
		BA	2,5,6	5-160X	5-1410X	
F350 SUPER DUTY						
2007-2008		AE	1		SPL55-4X	
		AE	2	5-178X	5-1350X	
		AE	5,6,7	5-160X	5-1410X	
		AW	1		SPL55-4X	
		AW	2	5-178X	5-1350X	
		AW	5,6,7	5-160X	5-1410X	
		BA	1		SPL55-4X	
		BA	2	5-178X	5-1350X	
		BA	5,6	5-160X	5-1410X	
2009	Exc. XL XL	AE	1		SPL55-4X	
		AE	2	5-160X	5-1410X	
		AE	2	5-178X	5-1350X	
	FX4, HARLEY-DAVIDSON EDITION & KING RANCH LARIAT, XL & XLT	Exc. Cab & Chassis	AE	5,6,7	5-160X	5-1410X
		Cab & Chassis	AE	5,6,7	5-160X	5-1410X
		Cab & Chassis	AE	5,6,7	5-188X	SPL55X
	Exc. Cab & Chassis 137" WB, Dual Rear Wheels Cab & Chassis Dual Rear Wheels	AW	1		SPL55-4X	
		AW	2,5,6,7	5-160X	5-1410X	
		BA	1		SPL55-4X	
		BA	2	5-178X	5-1350X	
		BA	5,6	5-160X	5-1410X	
		BA	5,6	5-188X	SPL55X	

4WD

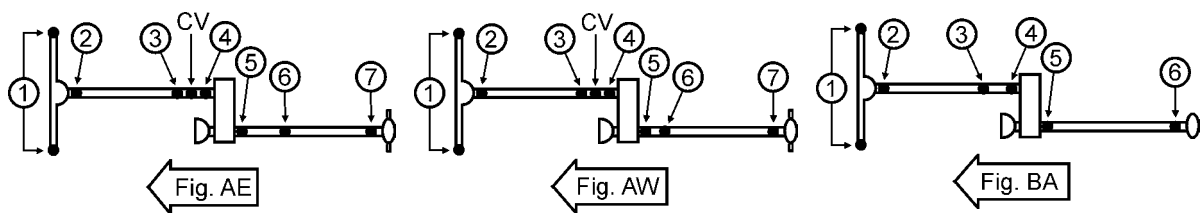

Important: See Safety Information in General Information Section (J300P-GI)

Year	Model & Description	Fig.	Location	Spicer Part No.	SPL Part No.
------	---------------------	------	----------	-----------------	--------------

FORD

F350 SUPER DUTY

2010	w/5.4L Gas Eng. CABELA'S, HARLEY-DAVIDSON EDITION, KING RANCH, LARIAT & XLT XL CABELA'S, HARLEY-DAVIDSON EDITION & KING RANCH LARIAT, XL & XLT Exc. Cab & Chassis Cab & Chassis	AE	1		SPL55-4X
		AE	2	5-160X	5-1410X
		AE	2	5-178X	5-1350X
		AE	5,6,7	5-160X	5-1410X
		AE	5,6,7	5-160X	5-1410X
		AE	5,6,7	5-188X	SPL55X
	XL & XLT Exc. Cab & Chassis 137" WB Single Rear Wheels XL & XLT Exc. Cab & Chassis 141.8" WB LARIAT Exc. Cab & Chassis	AW	1		SPL55-4X
		AW	2	5-160X	5-1410X
		AW	5,6,7	5-160X	5-1410X
		AW	5,6,7	5-160X	5-1410X
		AW	5,6,7	5-160X	5-1410X
		AW	5,6,7	5-160X	5-1410X
	CABELA'S XL & XLT Cab & Chassis Dual Rear Wheels XL & XLT Exc. Cab & Chassis 137" WB Dual Rear Wheels	BA	1		SPL55-4X
		BA	2	5-160X	5-1410X
		BA	5,6	5-160X	5-1410X
BA		5,6	5-188X	SPL55X	
BA		5,6	5-160X	5-1410X	

F350 SUPER DUTY

2011	XL KING RANCH, LARIAT & XLT KING RANCH LARIAT, XL & XLT Exc. Cab & Chassis Cab & Chassis	AE	1		SPL55-4X
		AE	2	5-178X	5-1350X
		AE	2,5	5-160X	5-1410X
		AE	5,6,7	5-160X	5-1410X
		AE	5,6,7	5-160X	5-1410X
		AE	5,6,7	5-188X	SPL55X
	XL & XLT Exc. Cab & Chassis 137" WB Single Rear Wheels XL & XLT Exc. Cab & Chassis 141.8" WB LARIAT Exc. Cab & Chassis	AW	1		SPL55-4X
		AW	2	5-160X	5-1410X
		AW	5,6,7	5-178X	5-1350X
		AW	5,6,7	5-178X	5-1350X
		AW	5,6,7	5-178X	5-1350X
	XL & XLT Exc. Cab & Chassis 137" WB Dual Rear Wheels XL & XLT Cab & Chassis Dual Rear Wheels	BA	1		SPL55-4X
		BA	2	5-160X	5-1410X
		BA	5,6	5-160X	5-1410X
		BA	5,6	5-188X	SPL55X

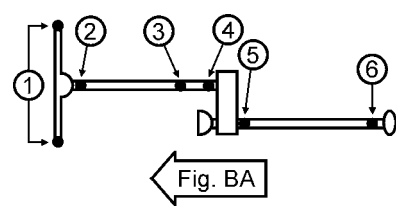
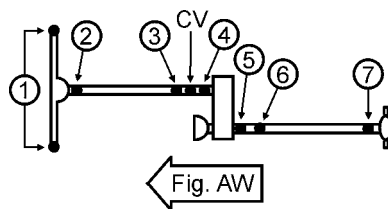
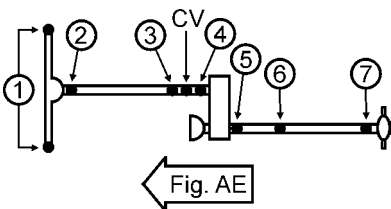

Year	Model & Description	Fig.	Location	Spicer Part No.	SPL Part No.
FORD					
F450 SUPER DUTY					
2007-2011		AC	1		SPL70-4X
		AC	2	5-178X	5-1350X
		AC	5,6,7,8	5-188X	SPL55X
		AE	1		SPL70-4X
		AE	2	5-178X	5-1350X
		AE	5,6,7	5-188X	SPL55X
		BA	1		SPL70-4X
		BA	2	5-178X	5-1350X
		BA	5,6	5-188X	SPL55X
F550 SUPER DUTY					
2007-2011		AC	1		SPL70-4X
		AC	2	5-178X	5-1350X
		AC	5,6,7,8	5-188X	SPL55X
		AE	1		SPL70-4X
		AE	2	5-178X	5-1350X
		AE	5,6,7	5-188X	SPL55X
		BA	1		SPL70-4X
		BA	2	5-178X	5-1350X
		BA	5,6	5-188X	SPL55X
RANGER					
2007-2011		L	2	5-153X	5-1310X
		L	4,5	5-213X	5-1330X
GMC					
CANYON					
2007-2011		L	2	5-153X	5-1310X
		L	4	5-213X	5-1330X
		L	5	5-212X	5-7436X
ENVOY					
2007-2009		L	2	5-350X	
		L	4,5	5-3147X	5-795X

4WD

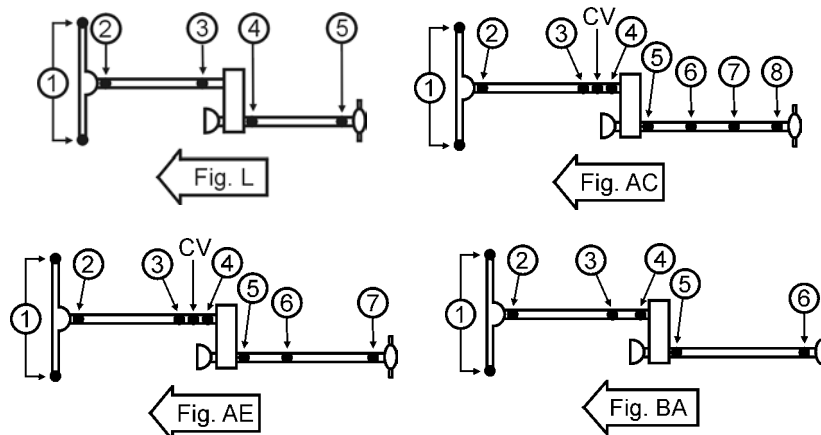

Important: See Safety Information in General Information Section (J300P-GI)

Year	Model & Description	Fig.	Location	Spicer Part No.	SPL Part No.
GMC					
SAVANA 1500					
2007-2011		L	2,3,4,5	5-3147X	5-795X
SIERRA 1500					
2007	all CLASSIC w/119" & 133" WB w/134" & 143.5" WB CLASSIC HYBRID, SL, SLE, SLT & WT w/119" & 133" WB CLASSIC SL, SLE, SLT & WT w/134" WB w/143.5" WB Drive Ratio 3.42 w/143.5" WB Exc. Drive Ratio 3.42 SLE, SLT & WT	L	2,3	5-3147X	5-795X
		L	4	5-178X	5-1350X
		L	4		5-3615X
		L	5	5-178X	5-1350X
		L	5	5-178X	5-1350X
		L	5	5-178X	5-1350X
		L	5		5-3615X
		L	4	5-178X	5-1350X
		L	5	5-178X	5-1350X
	all CLASSIC CLASSIC SL, SLE, SLT & WT 157.5" WB HD CLASSIC SLE	N	2,3	5-3147X	5-795X
		N	4,5,6		5-3615X
		N	4,5,6		5-3615X
	2008-2011		L	2,3	5-3147X
L			4,5	5-178X	5-1350X
SIERRA 2500					
2007	HD CLASSIC SL, SLE, SLT & WT w/6.0L Gas Eng. 133" & 143.5" WB 153" & 157.5" WBw/AT HD CLASSIC SL, SLE, SLT & WT w/6.6L Diesel Eng. 153" & 157.5" WB 133" & 143.5" WB HD CLASSIC SL, SLE, SLT & WT w/8.1L Gas Eng. 153" & 157.5" WB 133" & 143.5" WB HD SLE, SLT & WT w/6.0L Gas Eng. w/6.6L Diesel Eng. AAM 1485 Series	L	2,3	5-3147X	5-795X
		L	4,5	5-160X	5-1410X
		L	4,5	5-160X	5-1410X
		L	4,5	5-160X	5-1410X
		L	4,5	5-188X	SPL55-2X
		L	4,5	5-160X	5-1410X
	HD CLASSIC SL, SLE, SLT & WT w/6.0L Gas Eng. 153" & 157.5" WBw/MT 167" WB HD CLASSIC SL, SLE, SLT & WT w/6.6L Diesel Eng. 167" WB HD CLASSIC SL, SLE, SLT & WT w/8.1L Gas Eng. 167" WB HD SLE, SLT & WT w/6.0L Gas Eng. HD SLE, SLT & WT w/6.6L Diesel Eng. AAM 1485 Series	L	4,5	5-188X	SPL55-2X
		L	4,5	5-160X	5-1410X
		L	4,5	5-3206X	
		N	2,3	5-3147X	5-795X
		N	4	5-160X	5-1410X
		N	5,6	5-160X	5-1410X
		N	5,6	5-160X	5-1410X
		N	5,6	5-160X	5-1410X
		N	5,6	5-160X	5-1410X
		N	5,6	5-160X	5-1410X
		N	5,6	5-3206X	

4WD

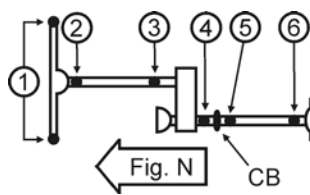
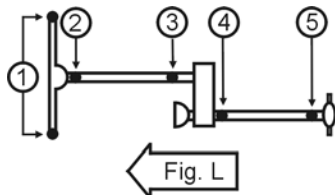

Year	Model & Description	Fig.	Location	Spicer Part No.	SPL Part No.
GMC					
SIERRA 2500					
2008-2009	w/6.0L Gas Eng. w/6.6L Diesel Eng. AAM 1485 Series	L	2,3	5-3147X	5-795X
		L	4,5	5-160X	5-1410X
		L	4,5	5-3206X	
	w/6.0L Gas Eng. w/6.6L Diesel Eng. AAM 1485 Series	N	2,3	5-3147X	5-795X
		N	4,5,6	5-160X	5-1410X
		N	4,5,6	5-3206X	
2010	w/6.0L Gas & FF Eng. w/6.6L Diesel Eng. AAM 1485 Series	L	2,3	5-3147X	5-795X
		L	4,5	5-160X	5-1410X
		L	4,5	5-3206X	
	w/6.0L Gas Eng. w/6.6L Diesel Eng. AAM 1485 Series	N	2,3	5-3147X	5-795X
		N	4,5,6	5-160X	5-1410X
		N	4,5,6	5-3206X	
2011	w/6.0L FF Eng. w/6.6L Diesel Eng. 133.6" & 158.1" WB AAM 1485 Series	L	2,3	5-3147X	5-795X
		L	4,5	5-160X	5-1410X
		L	4,5	5-3206X	
	w/6.0L FF Eng. w/6.6L Diesel Eng. Exc. 133.6" & 158.1" WB AAM 1485 Series HD SLE, SLT & WT w/6.6L Diesel Eng. Exc. 133.6" & 158.1" WB AAM 1485 Series HD DENALI w/6.6L Diesel Eng. AAM 1485 Series	N	2,3	5-3147X	5-795X
		N	4,5,6	5-160X	5-1410X
		N	4,5,6	5-3206X	
		N	4,5,6	5-3206X	
		N	4,5,6	5-3206X	
SIERRA 3500					
2007	CLASSIC SL, SLE, SLT & WT w/6.0L Gas Eng. 133" & 137" WB 157.5" WB w/AT w/6.6L Diesel & 8.1L Gas Eng. 157.5" & 161.5" WB 133" WB	L	2,3	5-3147X	5-795X
		L	4,5	5-160X	5-1410X
		L	4,5	5-160X	5-1410X
		L	4,5	5-160X	5-1410X
		L	4,5	5-188X	SPL55-2X
	HD SLE, SLT & WT w/6.0L Gas & 6.6L Diesel Eng. 133" & 157.5" WB AAM 1485 Series	L	4,5	5-3206X	
		N	2,3	5-3147X	5-795X
	CLASSIC SL, SLE, SLT & WT w/6.0L Gas Eng. 157.5" WB w/MT 161.5" & 167" WB w/6.6L Diesel & 8.1L Gas Eng. 167" WB 161.5" & 185.5" WB	N	4,5,6	5-160X	5-1410X
		N	4,5,6	5-160X	5-1410X
		N	4,5,6	5-160X	5-1410X
		N	4,5,6	5-188X	SPL55-2X
		N	4,5,6	5-3206X	
	HD SLE, SLT & WT w/6.0L Gas Eng. 167" WB AAM 1485 Series w/6.6L Diesel, 167" WB, AAM 1485 Series	N	4,5,6	5-3206X	
		N	4,5,6	5-3206X	

4WD

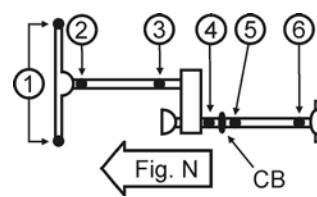
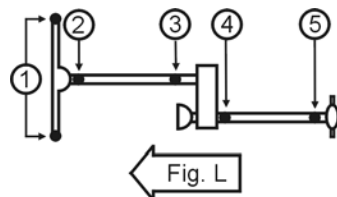

Important: See Safety Information in General Information Section (J300P-GI)

Year	Model & Description	Fig.	Location	Spicer Part No.	SPL Part No.
GMC					
SIERRA 3500					
2008-2011	AAM 1485 Series	L	2,3	5-3147X	5-795X
		L	4,5	5-3206X	
	AAM 1485 Series	N	2,3	5-3147X	5-795X
		N	4,5,6	5-3206X	
SIERRA DENALI					
2007-2008	w/6.2L Gas Eng.	L	2,3	5-3147X	5-795X
		L	4,5	5-178X	5-1350X
2009-2010	w/6.2L FF Eng.	L	2,3	5-3147X	5-795X
		L	4,5	5-178X	5-1350X
YUKON					
2007	DENALI & 1500 DENALI w/6.2L Gas Eng. XL 1500 & XL 2500 w/6.0L Gas Eng. XL 1500 w/5.3L FF Eng.	L	2,3	5-3147X	5-795X
		L	4,5	5-3147X	5-795X
		L	4,5	5-178X	5-1350X
		L	4,5	5-3147X	5-795X
2008	DENALI & 1500 DENALI w/6.2L Gas Eng. HYBRID w/6.0L Elec./Gas Eng. XL 1500 w/5.3L FF Eng. XL 1500 w/6.0L Gas Eng. XL 2500 w/6.0L Gas Eng.	L	2,3	5-3147X	5-795X
		L	4,5	5-3147X	5-795X
		L	4,5	5-178X	5-1350X
		L	4,5	5-3147X	5-795X
		L	4,5	5-178X	5-1350X
		L	4,5	5-160X	5-1410X
2009	DENALI & 1500 DENALI w/6.2L FF Eng. HYBRID w/6.0L Elec./Gas Eng. XL 1500 w/5.3L FF & 6.0L Gas Eng. XL 2500 w/6.0L Gas Eng.	L	2,3	5-3147X	5-795X
		L	4,5	5-178X	5-1350X
		L	4,5	5-178X	5-1350X
		L	4,5	5-178X	5-1350X
2010-2011	DENALI & 1500 DENALI w/6.2L FF Eng. HYBRID w/6.0L Elec./FF Eng. SLE, SLT & XL 1500 w/5.3L FF Eng. XL 1500 w/6.2L FF Eng. XL 2500 w/6.0L FF Eng.	L	4,5	5-178X	5-1350X
		L	4,5	5-178X	5-1350X
		L	4,5	5-178X	5-1350X
		L	4	5-178X	5-1350X
		L	4,5	5-160X	5-1410X
ISUZU					
ASCENDER					
2007-2008		L	2	5-350X	
		L	4,5	5-3147X	5-795X

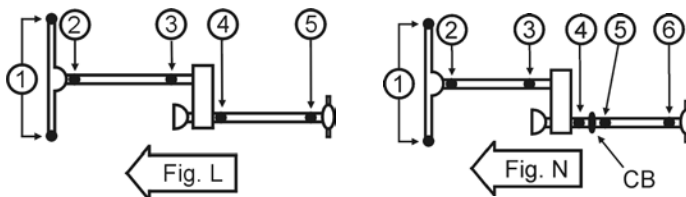

Year	Model & Description	Fig.	Location	Spicer Part No.	SPL Part No.
ISUZU					
I-370					
2007-2008		L	2	5-153X	5-153X
		L	4	5-213X	5-1330X
		L	5	5-212X	5-793X
JEEP					
LIBERTY					
2007	w/AT w/MT	L	2,3	5-153X	5-1310X
		L	2	5-213X	5-1330X
		L	3	5-153X	5-1310X
WRANGLER					
2007-2009	RUBICON & UNLIMITED RUBICON SAHARA & UNLIMITED SAHARA X & UNLIMITED X	BC	1		5004891
		BC	1	5-760X	
		BC	1	5-760X	
2010	ISLANDER RUBICON & UNLIMITED RUBICON	BC	1	5-760X	
		BC	1		5004891
2011	RUBICON & UNLIMITED RUBICON SAHARA & UNLIMITED SAHARA SPORT & UNLIMITED SPORT	BC	1		5004891
		BC	1	5-760X	
		BC	1	5-760X	
LEXUS					
2007-2011	GX470 & LX470	L	2,3,4,5	5-1510X	
LINCOLN					
MARK LT					
2007	w/Snap Ring Retainers w/Staked U-Joints	L	2,3	5-213X	5-1330X
		L	4,5	5-178X	5-1350X
		L	4,5	5-3203X	
		N	2,3	5-213X	5-1330X
		N	4,5,6	5-178X	5-1350X
2008		L	2,3,4,5	5-178X	5-1350X
		N	2,3,4,5,6	5-178X	5-1350X
NAVIGATOR					
2007-2011		L	2,3	5-178X	5-1350X
MAZDA					
B3000					
2007		L	2	5-153X	5-1310X
		L	4.5	5-213X	5-1330X

4WD

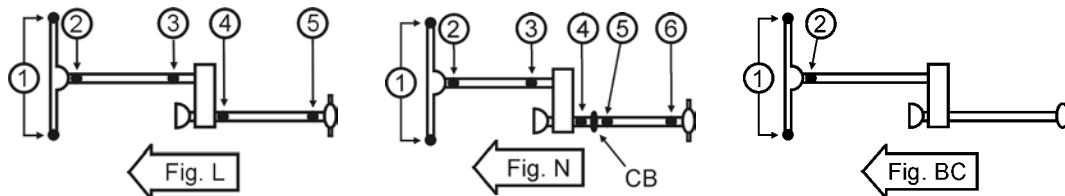

Important: See Safety Information in General Information Section (J300P-GI)

Year	Model & Description	Fig.	Location	Spicer Part No.	SPL Part No.
MAZDA					
B4000					
2007-2009		L	2	5-153X	5-1310X
		L	4.5	5-213X	5-1330X
MERCURY					
MOUNTAINEER					
2007-2010		L	2	5-153X	5-1310X
		L	4.5	5-213X	5-1330X
MITSUBISHI					
RAIDER					
2004-2009		L	2	5-153X	5-1310X
		L	4.5	5-213X	5-1330X
NISSAN					
ARMADA					
2007-2010		P	2	5-153X	5-1310X
		P	5		5-3616X
FRONTIER PICK-UP					
2007-2010		P	2,3,4	5-153X	5-1310X
		P	5,6	5-213X	5-1330X
PATHFINDER					
2007-2010		P	2	5-153X	5-1310X
		P	5	5-213X	5-1330X
TITAN PICK-UP					
2007	w/5.6L FF Eng.	P	2	5-153X	5-1310X
	w/5.6L Gas Eng.	P	5		5-3616X
2008	To 04/08	P	2	5-153X	5-1310X
		P	5		5-3616X
XTERRA					
2007-2010	w/4.0L Gas Eng.	P	2	5-153X	5-1310X
	w/4.0L Gas Eng.	P	5	5-213X	5-1330X
SAAB					
9-7X					
2007	4.2i, 5.3i	L	2,4,5	5-3147X	5-795X
2008-2009	AERO, 4.2i, 5.3i	L	2,4	5-350X	
	AERO, 4.2i, 5.3i	L	5	5-178X	5-1350X

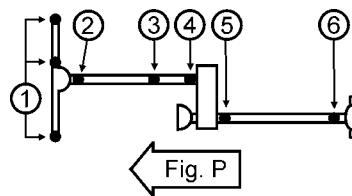
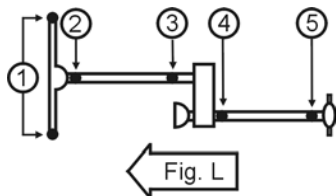

Year	Model & Description	Fig.	Location	Spicer Part No.	SPL Part No.
SUZUKI					
EQUATOR					
2009-2010	RMZ-4 & SPORT	P	2,5,6	5-153X	5-1310X
		P	3,4	5-213X	5-1330X
TOYOTA					
4-RUNNER					
2007-2011		L	2,3,4,5	5-1510X	
LAND CRUISER					
2007	w/4.7L Gas Eng.	L	2,3,4,5	5-1510X	
2008-2011	w/5.7L Gas Eng.	L	2,3,4,5	5-1510X	
SEQUOIA					
2007		L	4,5	5-1511X	
2008-2011		L	2,3	5-213X	5-1330X
		L	4,5		5009484
TACOMA					
2007-2010		AU	2,3,4		5-812X
		L	2,3		5-812X
2011		AU	3,4,5		5-812X
		L	2,3		5-812X
TUNDRA					
2007-2008		L	2,5		5009484
		L	3,4	5-213X	5-1330X
		N	2,5,6		5009484
		N	3,4	5-213X	5-1330X
2009	w/5.7L Gas & FF Eng. w/4.7L Gas Eng.	L	2,4		5009484
		L	2,4	5-213X	5-1330X
		L	3	5-213X	5-1330X
		L	5		5009484
	w/5.7L Gas & FF Eng. w/4.7L Gas Eng.	N	2,4		5009484
		N	2,4	5-213X	5-1330X
		N	3	5-213X	5-1330X
		N	5,6		5009484

4WD

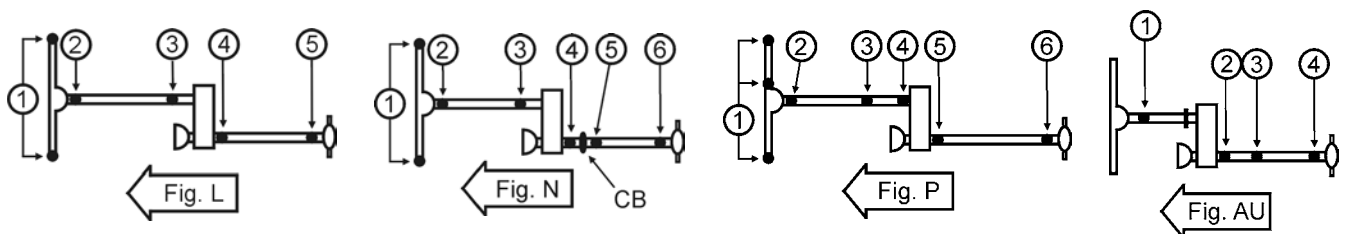

Important: See Safety Information in General Information Section (J300P-GI)

Year	Model & Description	Fig.	Location	Spicer Part No.	SPL Part No.
TOYOTA					
TUNDRA					
2010-2011	w/4.0L & 4.6L Gas Eng.	L	4		5009484
		L	2	5-213X	5-1330X
	w/5.7L Gas & FF Eng.	L	2,5		5009484
		L	3,4	5-213X	5-1330X
	w/4.0L & 4.6L Gas Eng.	N	2	5-213X	5-1330X
		N	4		5009484
	w/5.7L Gas & FF Eng.	N	2,5,6		5009484
		N	3,4	5-213X	5-1330X

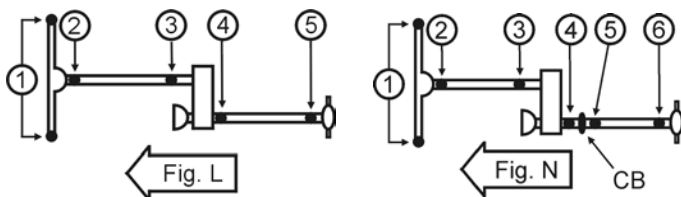
4WD

SPICER® DRIVESHAFT LUBRICATION INTERVALS*

SERIES	CITY	ON-HWY.	LINEHAUL	ON/OFF-HWY.
Spicer® 10-Series™ (1480 thru 1810 & SPL-90) Slip members also require lubrication.	5,000/8,000 mi (8,000/12,800 km) or 3 Months (whichever comes first)	10,000/15,000 mi (16,000/24,000 km) or 3 Months (whichever comes first)	10,000/15,000 mi (16,000/24,000 km) or 3 Months (whichever comes first)	5,000/8,000 mi (8,000/12,000 km) or 3 Months (whichever comes first)
Spicer Life Series® - Medium Duty (SPL-55, 70 & 100) Slip members are booted and permanently lubricated.	25,000 mi 40,000 km or 6 Months (whichever comes first)	25,000 mi 40,000 km or 6 Months (whichever comes first)	25,000 mi 40,000 km or 6 Months (whichever comes first)	25,000 mi 40,000 km or 6 Months (whichever comes first)
Spicer Life Series - Heavy Duty (SPL-140) Standard Spicer Life Series® u-joint. Slip members are booted and permanently lubricated.	25,000 mi 40,000 km or 6 Months (whichever comes first)	100,000 mi 160,000 km or 6 Months (whichever comes first)	100,000 mi 160,000 km or 6 Months (whichever comes first)	25,000 mi 40,000 km or 6 Months (whichever comes first)

SPICER LIFE XL® - FIRST LUBRICATION CYCLE*

Spicer Life XL® - Heavy Duty (SPL-170XL, & 250XL) Extended Lubrication u-joints. After initial miles (kilometers) or time is reached, the joints must be relubricated. Slip members are booted and permanently lubricated.	100,000 mi 160,000 km or 1 Year (whichever comes first)	350,000 mi 560,000 km or 3 Years (whichever comes first)	350,000 mi 560,000 km or 3 Years (whichever comes first)	100,000 mi 160,000 km or 1 Year (whichever comes first)
---	--	---	---	--

SPICER LIFE XL® - RELUBRICATION CYCLE*

Spicer Life XL - Heavy Duty (SPL-170XL & 250XL) Extended lubrication u-joints. Once greased, this relubrication interval must be followed. Slip members are booted and permanently lubricated.	25,000 mi 40,000 km or 6 months (whichever comes first)	100,000 mi 160,000 km or 6 months (whichever comes first)	100,000 mi 160,000 km or 6 months (whichever comes first)	25,000 mi 40,000 km or 6 months (whichever comes first)
---	--	--	--	--

*We require relubrication with Chevron Ultra-Duty EP-2 or a compatible lithium based grease meeting N.L.G.I. Grade 2 specifications as well as ASTM D4950 "LB" specifications.



NOTE: We recommend that all driveshafts be inspected for wear and damage every time the vehicle is serviced. This includes any scheduled and/or unscheduled maintenance that occurs within the driveshaft lube intervals.

City is defined as all applications that require a minimum of 90% of operation time within the city limits.

On-Highway is defined as all applications requiring less than 10% of operating time on gravel dirt or unpaved roads.

Linehaul is defined as 100% of operation time on smooth concrete or asphalt.

On/Off-Highway is defined as all applications operating primarily on paved roads, but requiring more than 10% of operating time on gravel, dirt or unpaved roads.

We recommend genuine Spicer®



Common U-Joint Kits By Series

K350

MSC

Driveline Series	Spicer® Service Kit (Greaseable unless noted)	Spicer Life™ OE Kit (Greaseable)	Spicer Life™ OE Kit (Greaseable) Replaced By #	Spicer Life™ OE Kit (Non-Greaseable)	Spicer Life™ OE Kit (Non-Greaseable) Replaced By #
1210	5-443X	—	—	—	—
1310/SPL22	5-153X	5-810X*/SPL22-7X	5-1310-1X*	5-785X / SPL22-1X	5-1310X
1310/SPL22 aluminum	—	—	—	5-786X / SPL22-2X	5-3613X
1310/SPL22 x 7260	—	—	—	5-788X / SPL22-4X	—
1310 (Wheel Joint)	5-297-1X*	—	—	5-760X	—
1330/SPL25	5-213X	5-812X*/SPL25-10X	5-1330-1X*	5-790X / SPL25-1X	5-1330X
1330/SPL25 aluminum	—	—	—	5-791X / SPL25-2X	5-3614X
1350/SPL30	5-178X	5-1350-1X	—	5-799X / SPL30-1X	5-1350X
1350/SPL30 aluminum	—	—	—	5-791X / SPL30-2X	5-3615X
1355 AAM	5-3208X◆	—	—	—	—
1410/SPL36	5-160X	—	5-1410-1X*	5-801X / SPL36-1X	5-1410X
1410/SPL36 aluminum	—	—	—	5-802X / SPL36-2X	5-3616X
1415 AAM	5-3207X◆	—	—	—	—
1480/SPL55	5-188X	SPL55-1X	—	5-803X / SPL55X	—
1480/SPL55 (Wheel Joint)	—	SPL55-4X	—	5-806X / SPL55-3X	—
1485 AAM	5-3206X◆	—	—	—	—
1485 AAM (Wheel Joint)	—	—	—	5006813	—
1550/SPL70	5-155X	SPL70-1X	—	5-808X / SPL70X	—
1550/SPL70 (Wheel Joint)	—	SPL70-4X	—	SPL70-3X	—
7260	5-1306X	—	—	5-789X / SPL22-8X	—
7290	5-1309X	—	—	5-811X / SPL25-9X	—
1310SPEC/SPL22 SPEC	5-1201X	—	—	5-787X / SPL22-3X	5-7439X
1330SPEC/SPL25 SPEC	5-1204X	—	—	5-792X / SPL25-3X	5-7438X
1330/SPL25 x S44	5-212X	—	—	5-793X / SPL25-4X	5-7436X
S44	5-3147X	—	—	5-795X / SPL25-6X	—
1350 x S44	5-3205X	—	—	—	—
1330/SPL25 x 7290	—	—	—	5-796X / SPL25-7X	5-7437X
SPL90	—	SPL90X	SPL100-1X	—	—
SPL100	—	SPL100-1X	—	—	—
1610 (Full Round)	5-279X■	—	—	—	—
1610 (Half Round)	5-674X■	—	—	—	—
1650 (Full Round)	5-165X■	—	—	—	—
1710 (Full Round)	5-280X■	—	—	—	—
1710 (Half Round)	5-675X■	—	—	—	—
SPL140	—	SPL140X	—	—	—
1760 (Full Round)	5-407X■	—	—	—	—
1760 (Half Round)	5-677X■	—	—	—	—
SPL170	—	SPL170X	SPL170-4X	—	—
SPL170	—	SPL170X	SPL170-3X	—	—
1800 (Full Round)	5-124X■	—	—	—	—
1810 (Full Round)	5-281X■	—	—	—	—
1810 (Half Round)	5-676X■	—	—	—	—
SPL250X	—	SPL250X	SPL250-3X	—	—
1880 (Full Round)	5-308X■	—	—	—	—

■ OE Kit *Zerk in cap ◆Non-Greaseable

Conversion Kit Number	Series Joined	Converts Yokes Using Kit Number	Greasable (Y/N)	Page Number
5-134X	Spicer 1310 to Spicer 1330	5-153X & 5-213X	Y	277
5-186X	Spicer 1850 to Mechanics 9C/92N/88WB	5-185X & 5-9001X	Y	285
5-187X	Spicer 1850 to Mechanics 9C/92N/88WB	5-185X & 5-9000X	Y	285
5-212X	Spicer 1330 to Saginaw S44	5-1203X & 5-3147X	Y	283
5-220X	Spicer 1550 to Mechanics 6C/62N	5-155X & 5-6000X	Y	285
5-221X	Spicer 1550 to Mechanics 6C/62N	5-155X & 5-6006X	Y	285
5-248X	Spicer 1110 to Spicer 1210	5-111X & 5-443X	Y	283
5-291X	Spicer 1310 to Mechanics 2C	5-153X & 5-2002X	Y	285
5-324X	Spicer 1810 to Mechanics 9C/92N	5-281X & 5-9001X	Y	291
5-326X	Spicer 1880 to Mechanics 9C/92N	5-308X & 5-9001X	Y	291
5-327X	Spicer 1880 to Mechanics 9C/92N	5-308X & 5-9000X	Y	291
5-328X	Spicer 1550 to Rockwell 58WB	5-155X & 5800X	Y	285
5-329X	Spicer 1550 to Rockwell 58WB	5-155X & 58WB(HWT)	Y	285
5-330X	Spicer 1650 to Mechanics 7C/72N	5-165X & 5-7105X	Y	285
5-331X	Spicer 1650 to Mechanics 7C/72N	5-165X & 7C/72N(HWT)	Y	285
5-345X	Spicer 1410 to Mechanics 4C	5-160X & 5-4143X	Y	285
5-346X	Spicer 1410 to Mechanics 4C	5-160X & 5-4002X	Y	285
5-347X	Spicer 1480 to Mechanics 5C	5-188X & 5-5177X	Y	285
5-348X	Spicer 1480 to Mechanics 5C	5-188X & 5-5000X	Y	285
5-353X	Spicer 1310 to Detroit 7260	5-153X & 5-1306X	Y	283
5-354X	Spicer 1310 to Detroit 7290	5-153X & 5-1309X	Y	284
5-356X	Spicer 1310 to Mechanics 3C	5-153X & 5-3000X	Y	285
5-357X	Spicer 1410 to Chrysler 5380	5-160X & 5-1301X	Y	284
5-430X	Spicer 1000 to Rockwell L6N	5-170X & 5-92X	Y	281
5-460X	Spicer 1310 to Spicer 1350	5-153X & 5-178X	Y	277
5-527X	Detroit 7260 to Detroit 7290	5-1306X & 5-1309X	Y	281
5-541X	Spicer 1330 to Saginaw S44	5-1203X & 5-3147X	Y	283
5-599X	Spicer 1330 to Detroit 7260	5-213X & 5-1306X	Y	283
5-648X	Spicer 1330 to Spicer 1350	5-213X & 5-178X	Y	278
5-793X	Spicer 1330 to Saginaw S44	5-1203X & 5-3147X	Y	284
5-796X	Spicer 1330 to Detroit 7290	5-1203X & 5-1309X	N	284
5-1312X	Spicer 1330SPEC to Saginaw S44	5-1204X & 5-3147X	Y	284
5-1313X	Spicer 1350 to 1330SPEC	5-178X & 5-1204X	Y	284
5-3205X	Spicer 1350 to Saginaw S44	5-178X & 5-3147X	Y	284
5-3022X	Spicer 1310 to Saginaw S44	5-153X & 5-3147X	Y	283
5-3163X	Chrysler/Detroit 7290 to Saginaw S44	5-1309X & 5-3147X	N	282
5C-3X	Spicer 1480 to Mechanics 5C	5-188X & 5-5177X	Y	285
5C-5X	Spicer 1480 to Mechanics 5C	5-188X & 5-5000X	Y	285
6C-3X	Spicer 1550 to Mechanics 6C/62N	5-155X & 5-6006X	Y	285
6C-5X	Spicer 1550 to Mechanics 6C/62N	5-155X & 5-6000X	Y	285

U-Bolt	Series	Spicer® Kit Number	Spicer® U-Bolt Assy	Recommended Bolt Torque	
	1280	5-200X	2-94-28X	14-17 Lb. Ft.	
	1310/SPL22	5-153X	2-94-28X	14-17 Lb. Ft.	
	1330/SPL25	5-213X	2-94-28X	14-17 Lb. Ft.	
	1350/SPL30	5-178X	3-94-18X	20-24 Lb. Ft.	
	1410/SPL36	5-160X	3-94-18X	20-24 Lb. Ft.	
	1480/SPL55	5-188X	3-94-28X	32-37 Lb. Ft.	
	1550/SPL70	5-155X	3-94-28X	32-37 Lb. Ft.	
Bearing Strap	Series	Spicer® Kit Number	Spicer® Strap Kit Assy	Recommended Bolt Torque	
	SPL90	SPL90X	90-70-28X	45-60 Lb. Ft.	
	1210	5-443X	2-70-18X	13-18 Lb. Ft.	
	1280	5-200X	2-70-18X	13-18 Lb. Ft.	
	1310/SPL22	5-153X	2-70-18X	13-18 Lb. Ft.	
	1330/SPL25	5-213X	2-70-18X	13-18 Lb. Ft.	
	3R/S44	5-3147X	2-70-48X	30-35 Lb. Ft.	
	1350/SPL30	5-178X	3-70-28X	30-35 Lb. Ft.	
	1350SPEC ♦		2-70-48X	25-30 Lb. Ft.	
	1410/SPL36	5-160X	3-70-28X	30-35 Lb. Ft.	
	1480/SPL55	5-188X	3-70-38X	55-60 Lb. Ft.	
	1550/SPL70	5-155X	3-70-38X	55-60 Lb. Ft.	
	1610	5-438X	5-70-28X	55-60 Lb. Ft.	
	1710	5-515X	6.5-70-18X	130-135 Lb. Ft.	
	1710	5-515X	212214X■	130-135 Lb. Ft.	
	1760	5-469X	6.5-70-18X	130-135 Lb. Ft.	
	1760	5-469X	212214X■	130-135 Lb. Ft.	
	1810	5-510X	6.5-70-18X	130-135 Lb. Ft.	
	1810	5-510X	212214X■	130-135 Lb. Ft.	
	Cap & Bolt	Series	Spicer® Kit Number	Spicer® Cap & Bolt Assy	Recommended Bolt Torque
		1650	5-165X	5-70-18X	77-103 Lb. Ft.
1850		5-185X	8-70-18X	110-147 Lb. Ft.	
1850		5-227X	8-70-18X	110-147 Lb. Ft.	
1910◀		5-316X	N.S.S.	110-147 Lb. Ft.	
1950◀		5-339X	9-70-18X	271-362 Lb. Ft.	
2010◀		5-371X	N.S.S.	102-118 Lb. Ft.	
2050◀		5-340X	9-70-28X	744-844 Lb. Ft.	
2110◀		5-372X	N.S.S.	171-197 Lb. Ft.	
2150◀		5-298X	9-70-38X	744-844 Lb. Ft.	
2210◀		5-373X	N.S.S.	260-298 Lb. Ft.	



Warning: Bearing strap retaining bolts should **NOT** be reused

- ♦ Strap kit 1350 Series "Special" for Corvette with metric bolts 3-70-48X (torque 25-30 Lb. Ft.) also fits some Dodge Viper.
- Kit has "cast" style strap
- ◀ For reference only; these driveline series are not serviced by Dana Spicer Service Parts

Bearing Plate

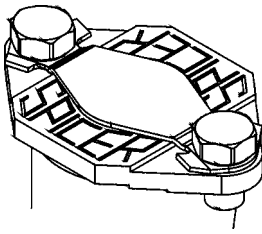



Warning: Self locking bolts should **NOT** be reused

Series	Spicer® Kit Number	Bolt Part Number	Lockstrap Part Number	Recommended Bolt Torque
1610	*5-279X	5-73-709	N.A.	26-35 Lb. Ft.
1710	*5-280X	6-73-209	N.A.	38-48 Lb. Ft.
1760	*5-407X	6-73-209	N.A.	38-48 Lb. Ft.
1810	*5-281X	6-73-209	N.A.	38-48 Lb. Ft.
1880	*5-308X	7-73-315	N.A.	60-70 Lb. Ft.
1610	5-654X	5-73-109	98-1741	17-24 Lb. Ft.
1710	5-656X	6-73-109	230323	32-42 Lb. Ft.
1760	5-658X	6-73-109	230323	32-42 Lb. Ft.
1810	5-660X	6-73-109	230323	32-42 Lb. Ft.
1880	5-668X	7-73-115	231009	50-66 Lb. Ft.

*these kits use self-locking bolts with lock patch.

Series	Spicer® Kit Number	Spicer® Strap Kit Assy	OLD “Yellow/Gold” Attaching Bolt Part Number	Recommended Bolt Torque	NEW “Green” Attaching Bolt Part Number	Recommended Bolt Torque
SPL140	SPL140X	140-70-18X	12-73-125M	115-135 Lb. Ft.	5007417	115-135 Lb. Ft.
SPL170	SPL170X	170-70-18X	12-73-125M	115-135 Lb. Ft.	5007417	115-135 Lb. Ft.
SPL250	SPL250X	250-70-18X	12-73-125M	115-135 Lb. Ft.	5007417	115-135 Lb. Ft.

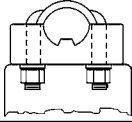
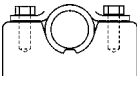
Originally SPL140 and SPL250 Series bearing retainer and u-joint kits included bolt part number 12-73-125M, which is YELLOW/GOLD in color. The newer bolt part number, 5007417, is GREEN in color. This was a running change that began in the second quarter of 2006.

Spicer Part Number	Original Equipment		Bearing Diameter	Spicer Part Number			
	Mfg.	Series		U-Bolt 	Strap Kit 	Outside Snap Ring 	Inside Snap Ring 
5-101X	Spicer	1110	.938"	-	-	1-7-29	-
5-103X	Spicer	1000SG	.938"	-	-	-	10-7-29
5-105X	Spicer	1100/1110	1.000"	-	-	-	230093
5-111X	Spicer	1100	.938"	-	-	1-7-29	-
5-129X	Spicer	1240	1.126"	-	-	2-7-149	-
5-134X	Spicer	1310/1330	1.063"	2-94-28X	2-70-18X	2-7-29	-
5-153X	Spicer	1310	1.063"	2-94-28X	2-70-18X	2-7-29	-
5-155X	Spicer	1550	1.375"	3-94-28X	3-70-38X	3-7-109	-
5-160X	Spicer	1410	1.188"	3-94-18X	3-70-28X	3-7-38	-
5-170X	Spicer	1000	.938"	-	-	-	10-7-29
5-178X	Spicer	1350	1.188"	3-94-18X	3-70-28X	3-7-38	-
5-188X	Spicer	1480	1.375"	3-94-28X	3-70-38X	3-7-89	-
5-200X	Spicer	1280	1.063"	2-94-28X	2-70-18X	2-7-29	-
5-212X	Mechanics / Spicer	3RL/1330	1.063" x 1.125"	-	2-70-18X	2-7-29	2-7-299
5-213X	Spicer	1330	1.063"	2-94-28X	2-70-18X	2-7-29	-
5-260X	Spicer	1310WJ	1.063"	-	-	-	2-7-99
5-297X	Spicer	1310WJ	1.188"	-	-	-	3-7-99
5-332X	Spicer	1480WJ	1.375"	-	-	-	3-7-129
5-350X	Spicer	1310	1.063"	2-94-28X	-	-	2-7-99
5-353X	Spicer / Detroit	1310/7260	1.063" X 1.078"	-	-	2-7-29	2-7-99
5-433-1X	Spicer	1310	1.063"	2-94-28X	-	2-7-29	-
5-443X	Spicer	1210	1.063"	2-94-28X	2-70-18X	2-7-29	-
5-541X	Mechanics / Spicer	3RL/1330	1.063" X 1.125"	-	2-70-18X	2-7-29	2-7-299
5-1200X	Cleveland / Spicer	S55/1310	1.063"	2-94-28X	-	2-7-29	2-7-99
5-1201X	Cleveland	S55	1.063" X 1.125"	2-94-58X	-	2-7-29	2-7-99
5-1203X	Cleveland / Spicer	P55/1330	1.063"	2-94-28X	-	2-7-29	2-7-99
5-1204X	Cleveland / Spicer	P55/1330	1.063" X 1.125"	2-94-58X	-	2-7-29	2-7-99
5-1205X	Cleveland / Spicer	R55/1350	1.188"	3-94-18X	3-70-28X	3-7-39	3-7-99
5-1206X	Cleveland / Spicer	O55/1410	1.188"	3-94-18X	3-70-28X	3-7-39	3-7-99
5-1306X	Detroit	7260	1.078"	-	2-70-38X	-	2-7-99
5-1309X	Detroit	7290	1.125"	-	-	-	2-7-299
5-2011X	Mechanics	2R	1.000"	-	2-70-18X	-	230093
5-3011X	Mechanics	3R	1.125"	-	2-70-28X	-	2-7-299
5-3022X	Mechanics	3R	1.063" X 1.125"	-	-	2-7-29	2-7-299
5-3147X	Saginaw / Mechanics	3R	1.125"	-	2-70-48X	-	2-7-299

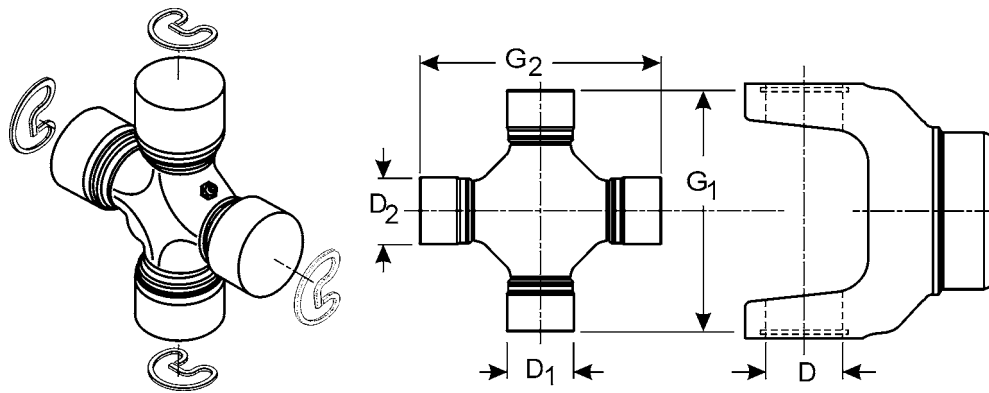

G1 Over Caps	D1 Bearing cap Diameter	G2 Over Caps	D2 Bearing cap Diameter	OE Mfg.	OE Series	Converts From this Series	To this Series Part	Greasable (Y=yes N=no)	Spicer Part Number
1.732	.811	1.732	.811	SPICER ITALCARDANO	44-B			N	050576000
1.850	.732	1.850	.732	SPICER ITALCARDANO	47-B			Y	050560000
2.046	.750	2.046	.750	SPICER ITALCARDANO	U-30			Y	050910000
2.126	.866	2.126	.866	BONDIOLI PAVESI	SERIES 1			Y	5-3200X
2.165	.866	2.165	.866	WALTERSCHEID	2100				040116•
2.409	.938	2.409	.938	SPICER	1100-SG			Y	5-102X•
2.411	.938	2.411	.938	SPICER ITALCARDANO	61-B OR 1100			Y	050701000
2.411	.938	2.411	.938	SPICER	1100			N	5-101X
2.411	.938	2.411	.938	SPICER	1100			Y	5-111X
									5-111X was replaced by 5-101X
2.438	1.062	2.438	1.062	SPICER	1210			Y	5-443X
									Lube fitting in brg. cap
2.438	1.062	2.438	1.062	SPICER	1210			N	5-526X
									5-526X was replaced by 5-443X; Has metal back seals
2.438	1.062	2.438	1.062	SPICER	1210			N	5-547X
									5-547X was replaced by 5-443X; Has spacer in brg cap; has metal back seals
2.438	1.062	2.438	1.062	SPICER	1210			Y	5-554X
									Lube fitting in brg. cap, Has metal back seals
2.438	1.062	2.438	1.062	SPICER	1210			N	5-736X•
2.498	.984	2.498	.984	DODGE COLT				Y	5-1503X
2.679	1.125	2.679	1.125	ROCKWELL	L14N	1240	L14N	Y	5-129X
2.931	.882	2.931	.882	ROCKWELL	1FR-AG			Y	5-264X
									4-round knurled caps; No brgs in brg cap
2.933	1.063	2.933	1.063	WALTERSCHEID	2300				044444•
2.937	1.063	2.937	1.063	BONDIOLI PAVESI	SERIES 4				5-3204X
2.938	1.063	2.938	1.063	SPICER	1300			Y	5-4X•
2.939	1.062	2.939	1.062	SPICER ITALCARDANO	75-B			Y	050585000
2.993	1.260	2.993	1.260	WALTERSCHEID	2400				312410•
3.207	1.250	3.207	1.250	ROCKWELL	35N	1340	35N	Y	5-243X
3.219	1.062	3.219	1.062	SPICER	1310/SPL22			N	SPL22-1X
									SPL22-1X was replaced by 5-1310X
3.219	1.062	3.219	1.062	SPICER	1310/SPL22			N	SPL22-2X
									SPL22-2X was replaced by 5-1310X; Coated bearing caps

• Part is discontinued ■ Part is available until supply is exhausted ▲ Not sold separately

MSC

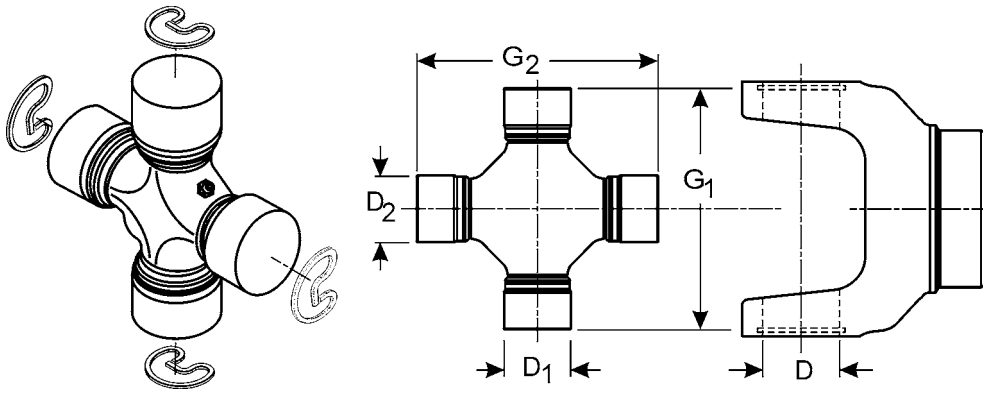

MSC

G1 Over Caps	D1 Bearing cap Diameter	G2 Over Caps	D2 Bearing cap Diameter	OE Mfg.	OE Series	Converts From this Series	To this Series Part	Greasable (Y=yes N=no)	Spicer Part Number
3.219	1.062	3.219	1.062	SPICER	SPL22 <i>SPL22-7X was replaced by 5-1310-1X; Spicer Life Series</i>				SPL22-7X
3.219	1.062	3.219	1.062	SPICER	1310/SPL22			N	5-1310X
3.219	1.062	3.219	1.062	SPICER	1310			Y	5-153X
3.219	1.062	3.219	1.062	SPICER	1310			Y	5-255X <i>5-255X was replaced by 5-153X; Has metal back seals</i>
3.219	1.062	3.219	1.062	SPICER	1310			Y	5-278X <i>5-278X was replaced by 5-153X; Flush lube fitting in cross</i>
3.219	1.062	3.219	1.062	SPICER	1310			N	5-3613X [▲] <i>Coated bearing caps; Spicer Life Series</i>
3.219	1.062	3.219	1.062	SPICER	1310			Y	5-419X <i>5-419X will be replaced by 5-153X when supply is exhausted; Has metal back seals</i>
3.219	1.062	3.219	1.062	SPICER	1310-CV			Y	5-433-1X <i>5-433-1X was replaced by 5-153X; Lube fitting in brg. cap</i>
3.219	1.062	3.219	1.062	SPICER	1310			Y	5-477X <i>5-477X will be replaced by 5-153X when supply is exhausted; Same as 5-153X except has black seals</i>
3.219	1.062	3.219	1.062	SPICER	1310			Y	5-511X <i>5-511X will be replaced by 5-153X when supply is exhausted; Has long grease zerk</i>
3.219	1.062	3.219	1.062	SPICER	1310			N	5-611-1X [•] <i>Includes various thickness snap rings</i>
3.219	1.062	3.219	1.062	SPICER	1310			N	5-785X <i>5-785X was replaced by 5-1310X; Spicer Life Series</i>
3.219	1.062	3.219	1.062	SPICER	1310			N	5-786X <i>5-786X was replaced by 5-785X; Coated bearing caps; Spicer Life Series</i>
3.219	1.062	3.219	1.062	SPICER	1310			Y	5-810X <i>5-810X was replaced by 5-1310-1X; Lube fitting in brg. cap; Spicer Life Series</i>
3.219	1.062	3.219	1.125	SPICER	1310SPEC/SPL22	S55	SPL22	N	SPL22-3X <i>SPL22-3X was replaced by 5-7439X</i>
3.219	1.062	3.219	1.125	SPICER	1310SPEC			Y	5-1201X <i>5-1201X was replaced by 5-7439X</i>
3.219	1.062	3.219	1.125	SPICER	1310SPEC			Y	5-719X [•]
3.219	1.062	3.219	1.125	SPICER	1310SPEC			N	5-787X <i>5-787X was replaced by 5-7439X; Spicer Life Series</i>
3.219	1.062	3.625	1.062	SPICER		1310	1330	Y	5-134X
3.219	1.062	3.625	1.188	SPICER		1310	1350	Y	5-460X
3.503	1.417	3.503	1.417	WALTERSCHEID	2500				312209 [•]
3.612	1.188	3.612	3.612	AAM	AAM 1355			N	5-3208X
3.622	1.181	3.622	1.181	WALTERSCHEID	W220				041662 [•]

• Part is discontinued ■ Part is available until supply is exhausted ▲ Not sold separately

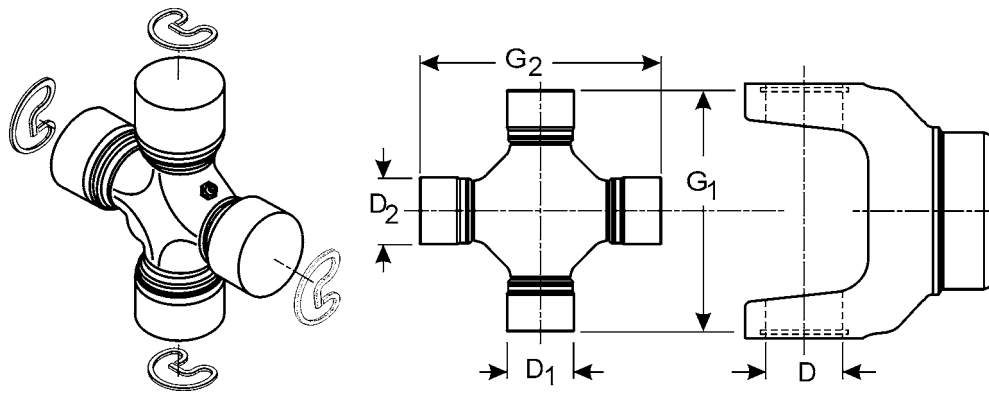

G1 Over Caps	D1 Bearing cap Diameter	G2 Over Caps	D2 Bearing cap Diameter	OE Mfg.	OE Series	Converts From this Series	To this Series Part	Greasable (Y=yes N=no)	Spicer Part Number
3.625	1.062	3.625	1.062	SPICER	1330/SPL25			N	SPL25-1X <i>SPL25-1X was replaced by 5-1330X</i>
3.625	1.062	3.625	1.062	SPICER	1330/SPL25			N	SPL25-2X <i>SPL25-2X was replaced by 5-3614X; Coated bearing caps</i>
3.625	1.062	3.625	1.062	SPICER	1330			Y	5-1203X <i>5-1203X will be replaced by 5-213X when supply is exhausted</i>
3.625	1.062	3.625	1.062	SPICER	1330/SPL25			N	5-1330X
3.625	1.062	3.625	1.062	SPICER	1330			Y	5-213X
3.625	1.062	3.625	1.062	SPICER	1330			Y	5-273X <i>5-273X was replaced by 5-213X; Has metal back seals</i>
3.625	1.062	3.625	1.062	SPICER	1330			N	5-3614X <i>Coated bearing caps; Spicer Life Series</i>
3.625	1.062	3.625	1.062	SPICER	1330			N	5-790X <i>5-790X was replaced by 5-1330X; Spicer Life Series</i>
3.625	1.062	3.625	1.062	SPICER	1330			N	5-791X <i>5-791X was replaced by 5-790X; Coated bearing caps; Spicer Life Series</i>
3.625	1.062	3.625	1.062	SPICER	SPL25/1330			Y	5-812X <i>5-812X was replaced by 5-1330-1X; Lube fitting in brg. cap Spicer Life Series</i>
3.625	1.062	3.625	1.062	SPICER	SPL25			N	5001919 <i>Lube fitting in brg. cap</i>
3.625	1.062	3.625	1.125	SPICER	1330SPEC/SPL25			N	SPL25-3X <i>SPL25-3X will be replaced by 5-7438X when supply is exhausted</i>
3.625	1.062	3.625	1.125	SPICER	1330SPEC			Y	5-1204X
3.625	1.062	3.625	1.125	SPICER	1330SPEC			N	5-792X <i>5-792X was replaced by 5-7438X; Spicer Life Series</i>
3.625	1.062	3.625	1.188	SPICER		1330	1350	Y	5-648X
3.625	1.188	3.625	1.188	SPICER	1350/SPL30			N	SPL30-1X <i>SPL30-1X was replaced by 5-1350X</i>
3.625	1.188	3.625	1.188	SPICER	SPL30			N	SPL30-2X <i>SPL30-2X was replaced by 5-3615X; Coated bearing caps</i>
3.625	1.188	3.625	1.188	SPICER	1350/SPL30			N	SPL30-3X• <i>2-Coated bearing caps, 2-Uncoated</i>
3.625	1.188	3.625	1.188	SPICER	1350/SPL30			N	SPL30-4X•
3.625	1.188	3.625	1.188	SPICER	1350/SPL30			N	5-1350X
3.625	1.188	3.625	1.188	SPICER	1350			Y	5-174X <i>5-174X was replaced by 5-178X; Has metal back seals</i>
3.625	1.188	3.625	1.188	SPICER	1350WJ			N	5-282X <i>5-282X was replaced by 5-1350X; Has metal back seals</i>

• Part is discontinued ■ Part is available until supply is exhausted ▲ Not sold separately

MSC

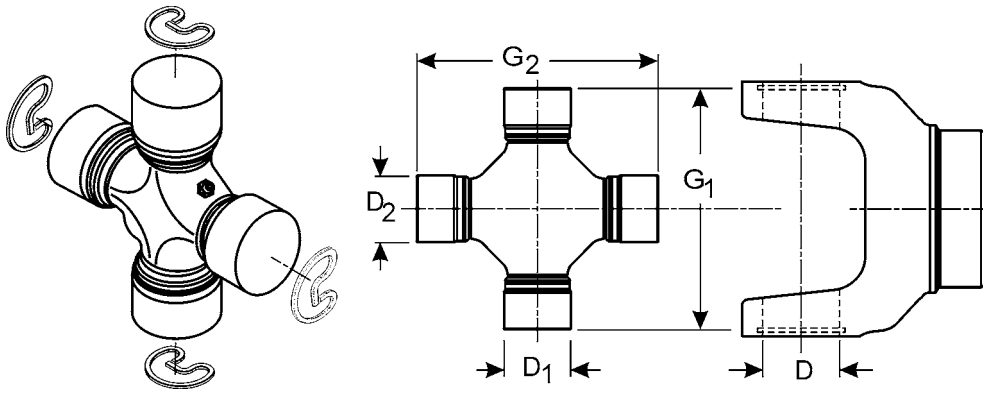

MSC

G1	D1	G2	D2	OE Mfg.	OE Series	Converts From this Series	To this Series Part	Greasable (Y=yes N=no)	Spicer Part Number
Over Caps	Bearing cap Diameter	Over Caps	Bearing cap Diameter						
3.625	1.188	3.625	1.188	SPICER	1350			N	5-3615X <i>Coated bearing caps; Spicer Life Series</i>
3.625	1.188	3.625	1.188	SPICER	1350			N	5-447X <i>5-447X was replaced by 5-3615X; Coated bearing caps</i>
3.625	1.188	3.625	1.188	SPICER	1350			N	5-471X <i>5-471X was replaced by 5-178X; Has metal back seals - spec for US govt.</i>
3.625	1.188	3.625	1.188	SPICER	1350			Y	5-480X*
3.625	1.188	3.625	1.188	SPICER	1350			Y	5-542X <i>5-542X was replaced by 5-1350-1X; Has metal back seals</i>
3.625	1.188	3.625	1.188	SPICER	1350			Y	5-584X <i>5-584X was replaced by 5-178X; Same as 5-178X except includes 45° Zerk</i>
3.625	1.188	3.625	1.188	SPICER	1350			N	5-800X <i>5-800X was replaced by 5-1350X; Coated bearing caps; Spicer Life Series</i>
3.625	1.188	3.625	1.188	SPICER	1350WJ			N	5-86X <i>5-86X was replaced by 5-1350X; Used in closed end Spicer front axle; no bearing cap seals</i>
3.625	1.188	3.625	1.188	SPICER	1350			Y	5-178X
3.625	1.188	3.625	1.188	SPICER	1350			N	5-799X <i>5-799X was replaced by 5-1350X; Spicer Life Series</i>
3.767	1.260	3.767	1.260	ITALCARDANO SPICER	96-B			Y	050207000
3.787	1.066	3.787	1.066	VISTEON SPECIAL	STAKED REPLACEMENT			N	5-3203X
3.900	1.005	3.900	1.005	BORG WARNER	3DR			Y	5-265X <i>No needle brg; 4-round knurled caps - No hardware incl.</i>
4.178	1.188	4.178	1.188	AAM	AAM 1415			N	5-3207X
4.178	1.375	4.178	1.375	AAM	AAM 1485			N	5-3206X
4.188	1.188	4.188	1.188	SPICER	1410/SPL36			N	SPL36-1X <i>SPL36-1X will be replaced by 5-1410X when supply is exhausted</i>
4.188	1.188	4.188	1.188	SPICER	1410/SPL36			N	SPL36-2X <i>SPL36-2X was replaced by SPL36-1X; Coated bearing caps</i>
4.188	1.188	4.188	1.188	SPICER	1410/SPL36			N	SPL36-3X <i>SPL36-3X was replaced by 5-1410X</i>
4.188	1.188	4.188	1.188	SPICER	1410/SPL36			N	SPL36-4X*
4.188	1.188	4.188	1.188	SPICER	1410/SPL36			N	5-1410X
4.188	1.188	4.188	1.188	SPICER	1410			Y	5-160X
4.188	1.188	4.188	1.188	SPICER	1410			N	5-3616X <i>Coated bearing caps; Spicer Life Series</i>
4.188	1.188	4.188	1.188	SPICER	1410			N	5-429X* <i>Has metal back seals</i>

• Part is discontinued ■ Part is available until supply is exhausted ▲ Not sold separately

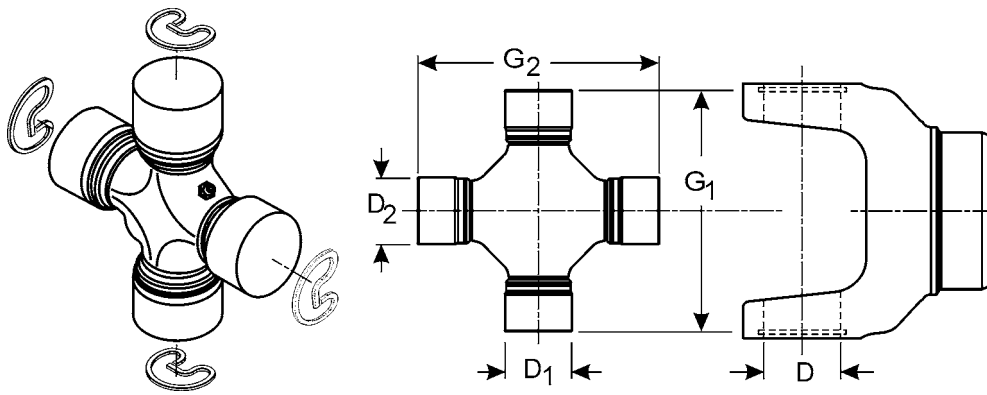

G1 Over Caps	D1 Bearing cap Diameter	G2 Over Caps	D2 Bearing cap Diameter	OE Mfg.	OE Series	Converts From this Series	To this Series Part	Greasable (Y=yes N=no)	Spicer Part Number
4.188	1.188	4.188	1.188	SPICER	1410			Y	5-462X <i>5-462X was replaced by 5-160X; Has metal back seals</i>
4.188	1.188	4.188	1.188	SPICER	1410			Y	5-481X <i>5-481X will be replaced by 5-160X when supply is exhausted</i>
4.188	1.188	4.188	1.188	SPICER	1410			N	5-641X <i>5-641X was replaced by 5-1410X</i>
4.188	1.188	4.188	1.188	SPICER	1410			N	5-801X <i>5-801X was replaced by 5-1410X; Spicer Life Series</i>
4.188	1.375	4.188	1.375	SPICER	1480/SPL55			Y	SPL55-1X
4.188	1.375	4.188	1.375	SPICER	1480/SPL55			N	SPL55-2X•
4.188	1.375	4.188	1.375	SPICER	1480/SPL55			N	SPL55X
4.188	1.375	4.188	1.375	WALTERSCHEID	2200			Y	044439•
4.188	1.375	4.188	1.375	SPICER	1480			Y	5-188X
4.188	1.375	4.188	1.375	SPICER	1480			Y	5-263X <i>5-263X will be replaced by 5-188X when supply is exhausted</i>
4.188	1.375	4.188	1.375	SPICER	1480			N	5-319X <i>5-319X was replaced by 5-188X; Has metal back seals</i>
4.188	1.375	4.188	1.375	SPICER	1480			Y	5-482X <i>5-482X was replaced by 5-188X</i>
4.188	1.375	4.188	1.375	SPICER	1480			N	5-803X <i>5-803X was replaced by SPL55X; Spicer Life Series</i>
4.188	1.375	4.188	1.375	SPICER	SPL55/1480			Y	5-804X <i>5-804X was replaced by SPL55-1X; Spicer Life Series</i>
4.312	1.531	4.312	1.531	ROCKWELL	55N			Y	5-432X•
4.957	1.625	4.957	1.625	SPICER	SPL100			Y	SPL100-1X <i>Dimensionally same as SPL90X</i>
4.957	1.625	4.957	1.625	SPICER	SPL90			Y	SPL90X <i>SPL90X was replaced by SPL100-1X</i>
4.964	1.375	4.964	1.375	SPICER	1550/SPL70			Y	SPL70-1X
4.964	1.375	4.964	1.375	SPICER	1550/SPL70			N	SPL70X
4.964	1.375	4.964	1.375	SPICER	1550			Y	5-155X
4.964	1.375	4.964	1.375	SPICER	1550			Y	5-275X <i>5-275X will be replaced by 5-155X when supply is exhausted; Has metal back seals</i>
4.964	1.375	4.964	1.375	SPICER	1550			Y	5-304X OEM Kit
4.964	1.375	4.964	1.375	SPICER	1550			Y	5-483X <i>5-483X was replaced by 5-155X</i>
4.964	1.375	4.964	1.375	SPICER	1550			Y	5-543X <i>Has metal back seals</i>

• Part is discontinued ■ Part is available until supply is exhausted ▲ Not sold separately

MSC

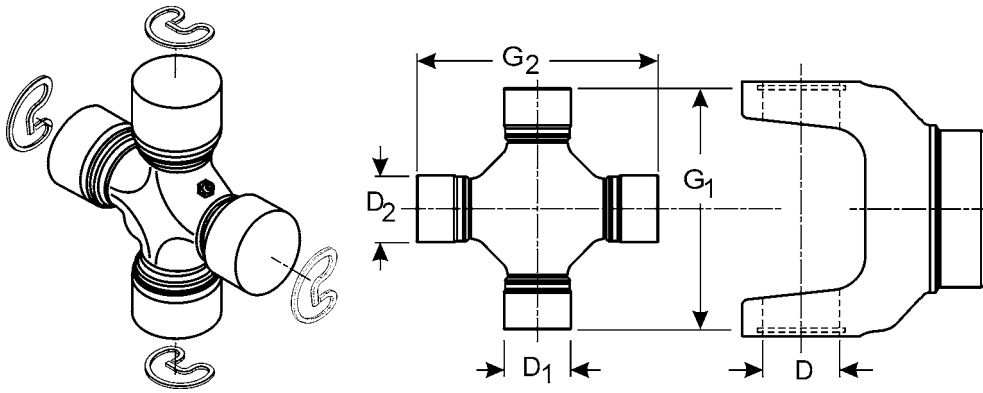

MSC

G1 Over Caps	D1 Bearing cap Diameter	G2 Over Caps	D2 Bearing cap Diameter	OE Mfg.	OE Series	Converts From this Series	To this Series Part	Greasable (Y=yes N=no)	Spicer Part Number
4.964	1.375	4.964	1.375	SPICER	1550			Y	5-546X▪
<i>2-Snap rings & 2-Thrust plates w/metric bolts</i>									
4.964	1.375	4.964	1.375	SPICER	1550			Y	5-778X
<i>Same as 5-275X but has 45° zerk, and metal back seals</i>									
4.964	1.375	4.964	1.375	SPICER	1550			N	5-808X
<i>5-808X was replaced by SPL70X; Spicer Life Series</i>									
5.590	1.625	5.590	1.623	SPICER	1650			Y	5-165X
6.011	1.980	6.011	1.980	ITALCARDANO				Y	050967100
<i>Has three hole plates instead of snap rings</i>									
8.092	2.186	8.092	2.186	SPICER	1850			Y	5-185X•

• Part is discontinued ■ Part is available until supply is exhausted ▲ Not sold separately

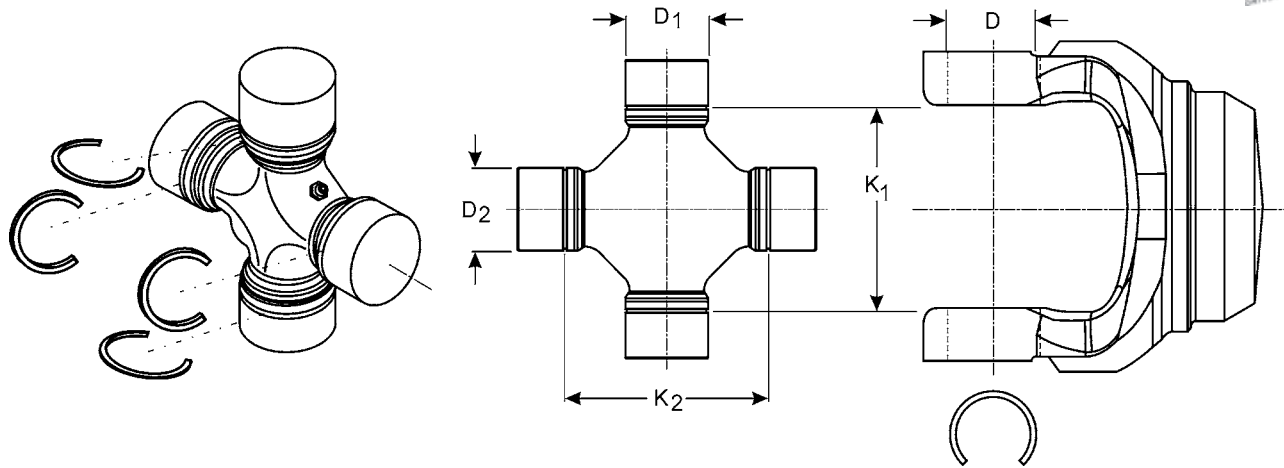

K1 Between Snap Rings	D1 Bearing cap Diameter	K2 Between Snap Rings	D2 Bearing cap Diameter	OE Mfg.	OE Series	Converts From this Series	To this Series Part	Greasable (Y=yes N=no)	Spicer Part Number
1.400	.867	1.400	.867	TOYOTA/NISSAN	STAKED REPLACEMENT				5-3202X <i>Lube fitting in brg cap</i>
1.445	.971	1.445	.971	ROCKWELL	L6N			Y	5-92X
1.482	.886	1.482	.886	MAZDA				N	5-1514X
1.496	.787	1.496	.787	DAT-TOY				N	5-1500X
1.500	.938	1.445	.971	ROCKWELL	L6N	1000	L6N	Y	5-430X
1.500	.938	1.500	.938	SPICER	1000			N	5-110X
1.500	.938	1.500	.938	SPICER	1000SG			Y	5-755X* <i>Used in aluminum steering shafts</i>
1.500	.938	1.500	.938	SPICER	1000			Y	5-170X <i>Used in PTO shafts</i>
1.500	.938	1.500	.938	SPICER	1000			Y	5-170-1X <i>Lube fitting in brg. cap</i>
1.500	.938	1.500	.938	SPICER	1000SG			Y	5-103X <i>Used in steel steering shafts</i>
1.640	1.062	1.640	1.062	SPICER	1210WJ			N	5-456X*
1.718	1.000	1.718	1.000	SPICER	1100			Y	5-105X
1.723	.984	1.723	.984	MAZDA				N	5-1504X*
1.734	.984	1.734	.984	DATSUN				N	5-1501X
1.828	1.062	1.828	1.062	ROCKWELL	L12N	1140	L12N	Y	5-242X
1.900	.947	1.900	.947	BMW/MAZDA	STAKED REPLACEMENT				5-3201X <i>Lube fitting in brg cap</i>
2.047	1.142	2.047	1.142	TOYOTA				N	5-1510X
2.080	1.142	2.080	1.142	CHEV LUV				Y	5-1515X
2.125	1.078	2.125	1.078	DETROIT	7260			N	5-789X <i>Spicer Life Series</i>
2.125	1.078	2.125	1.078	DETROIT	7260			N	SPL22-8X <i>SPL22-8X was replaced by 5-789X</i>
2.125	1.078	2.125	1.078	DETROIT	7260			Y	5-1306-1X <i>5-1306-1X will be replaced by 5-789X when supply is exhausted; Lube fitting in brg. cap</i>
2.125	1.078	2.125	1.078	DETROIT	7260			Y	5-1306X <i>5-1306X will be replaced by 5-789X when supply is exhausted</i>
2.125	1.078	2.125	1.078	MERCUISER	7260			Y	5-589X* <i>Mercuriser kit</i>
2.125	1.078	2.625	1.125	DETROIT	7260	7260	7290	Y	5-527X*
2.188	1.062	2.188	1.062	SPICER	1310WJ			N	5-260X

• Part is discontinued ■ Part is available until supply is exhausted ▲ Not sold separately

MSC

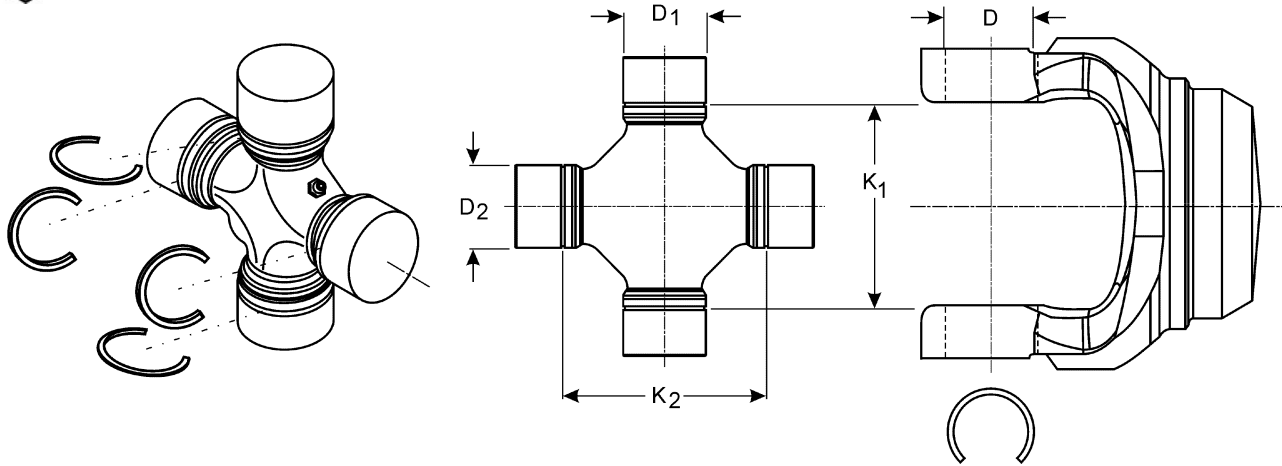

MSC

K1	D1	K2	D2	OE Mfg.	OE Series	Converts From this Series	To this Series Part	Greasable (Y=yes N=no)	Spicer Part Number
Between Snap Rings	Bearing cap Diameter	Between Snap Rings	Bearing cap Diameter						
2.188	1.062	2.188	1.062	SPICER	1310WJ <i>5-260-1X was replaced by 5-260X; Lube fitting in brg. cap</i>			Y	5-260-1X
2.188	1.062	2.188	1.062	SPICER	1310WJ <i>5-74X was replaced by 5-260X; Used in closed end, Spicer front axle</i>			N	5-74X
2.188	1.188	2.188	1.188	SPICER	1310WJ			N	5-760X
2.188	1.188	2.188	1.188	SPICER	1310WJ <i>5-297-1X was replaced by 5-760X; Lube fitting in brg. cap</i>			Y	5-297-1X
2.188	1.188	2.188	1.188	SPICER	1310WJ			N	5-297X <i>5-297X was replaced by 5-760X</i>
2.200	1.025	2.200	1.025	TOYOTA				Y	5-1508X
2.208	1.102	2.208	1.102	DATSUN				Y	5-1505X
2.409	1.188	2.409	1.188	SPICER	SPL30				5004891
2.343	1.062	2.343	1.062	SPICER	1310			Y	5-350X▪
2.344	1.000	2.344	1.000	MECHANICS	2R			Y	5-2011X▪
2.375	1.062	2.375	1.062	CLEVELAND	S55			Y	5-718X <i>Coated bearing caps</i>
2.375	1.062	2.375	1.062	CLEVELAND	S55 <i>5-1200X will be replaced by 5-153X when supply is exhausted</i>			Y	5-1200X
2.453	1.497	2.453	1.497	MERCEDES				Y	5-1506X•
2.520	1.260	2.520	1.260	TOYOTA				Y	5-1511X•
2.556	1.125	2.556	1.125	MECHANICS	S44			Y	5-3147X
2.556	1.125	2.556	1.125	MECHANICS	S44 <i>SPL25-6X will be replaced by 5-795X when supply is exhausted</i>			N	SPL25-6X
2.556	1.125	2.556	1.125	SPICER	SPL25/S44			N	5-795X <i>Spicer Life Series</i>
2.563	1.188	2.563	1.188	CLEVELAND	R55			Y	5-1205X•
2.625	1.125	2.625	1.125	DETROIT	7290			N	SPL25-9X <i>SPL25-9X was replaced by 5-811X</i>
2.625	1.125	2.625	1.125	DETROIT	7290			N	5-811X <i>Spicer Life Series</i>
2.625	1.125	2.625	1.125	DETROIT	7290 <i>5-1309X will be replaced by 5-811X when supply is exhausted</i>			Y	5-1309X
2.635	1.125	2.556	1.125	DETROIT/SAGINAW	7290/S44	7290	S44	N	5-3163X•
2.781	1.312	2.781	1.312	ROCKWELL	44R			Y	5-431X
2.920	1.375	2.920	1.375	AAM	1485WJ			N	5006813 <i>Spicer Life Series</i>

• Part is discontinued ■ Part is available until supply is exhausted ▲ Not sold separately

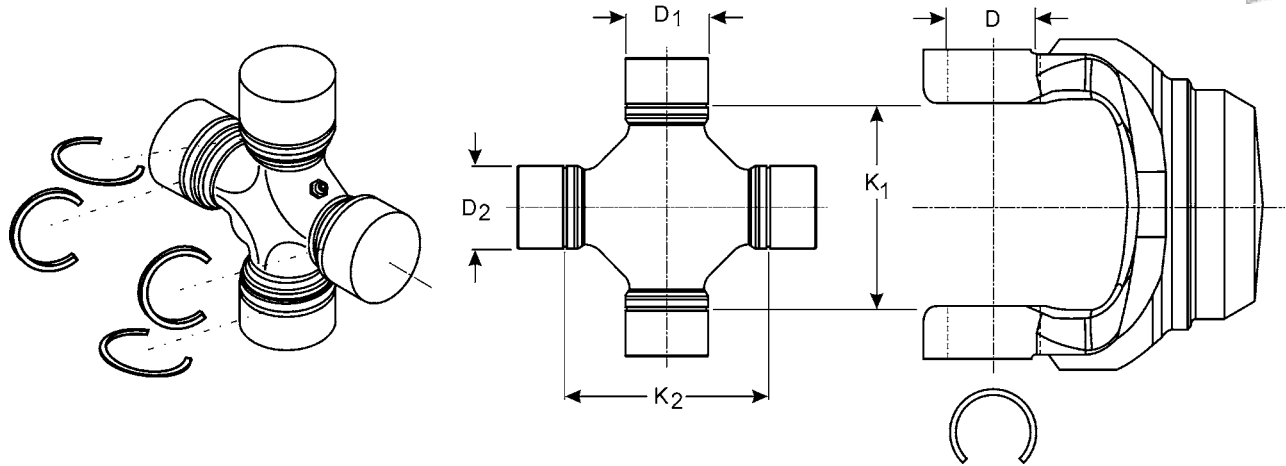

K1 Between Snap Rings	D1 Bearing cap Diameter	K2 Between Snap Rings	D2 Bearing cap Diameter	OE Mfg.	OE Series	Converts From this Series	To this Series Part	Greasable (Y=yes N=no)	Spicer Part Number
3.000	1.231	3.000	1.231	DETROIT	5380			Y	5-1301X
3.000	1.375	3.000	1.375	SPICER	1480WJ			N	5-88X
<i>5-88X was replaced by SPL55-3X; Used in closed end, Spicer front axle</i>									
3.000	1.375	3.000	1.375	SPICER	SPL55/1480WJ			Y	5-807X
<i>5-807X was replaced by SPL55-4X; Wheel Joint, Same as SPL55-4X</i>									
3.000	1.375	3.000	1.375	SPICER	SPL55/1480WJ			N	5-806X
<i>5-806X was replaced by SPL55-3X; Wheel Joint, Same as SPL55-3X</i>									
3.000	1.375	3.000	1.375	SPICER	1480WJ			N	5-332X
<i>5-332X was replaced by SPL55-3X; Can use 5-806X</i>									
3.000	1.375	3.000	1.375	SPICER	SPL55/1480WJ			Y	SPL55-4X
<i>Wheel Joint, Same as 5-807X</i>									
3.000	1.375	3.000	1.375	SPICER	SPL55/1480WJ			N	SPL55-3X
<i>Wheel Joint, Same as 5-806X</i>									
3.125	1.188	3.125	1.188	CLEVELAND	O55			Y	5-1206X
<i>5-1206X was replaced by 5004989</i>									
3.125	1.188	3.125	1.188	SPICER	SPL36/055			N	5004989
<i>Includes 4 inside and 4 outside snap rings</i>									
3.250	1.125	3.250	1.125	MECHANICS	4R			Y	5-4015X
3.780	1.375	3.780	1.375	SPICER	SPL70WJ			N	SPL70-3X
<i>SPL70-3X was replaced by SPL70-4X</i>									
3.780	1.375	3.780	1.375	SPICER	SPL70WJ			Y	SPL70-4X

MSC

• Part is discontinued ■ Part is available until supply is exhausted ▲ Not sold separately

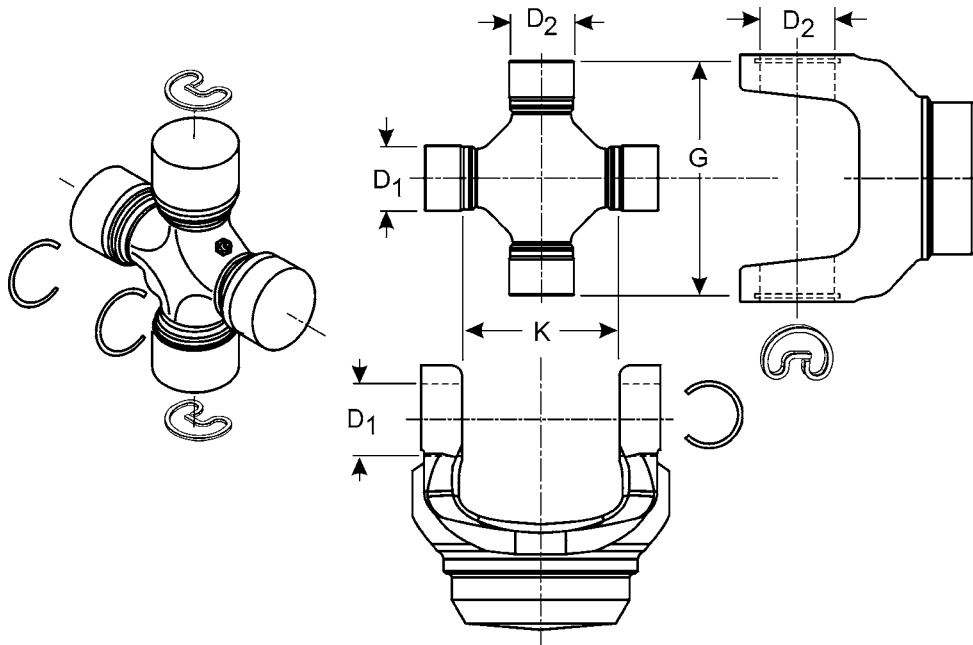

MSC

K	D1	G	D2	OE Mfg.	OE Series	Converts From this Series	To this Series Part	Greasable (Y=yes N=no)	Spicer Part Number
Inside Snap Ring Dimension	Inside Bearing cap Diameter	Outside Snap Ring Dimension	Outside Bearing cap Diameter						
1.719	1.000	2.438	1.062	SPICER	1110/1210	1110	1210	Y	5-248X <i>Grease zerk in center of cross</i>
1.719	1.000	2.438	1.062	SPICER	1110 SPEC			Y	5-249X <i>5-249X was replaced by 5-248X</i>
2.049	1.142	3.219	1.062	TOYOTA		TOYOTA	1310		5-721X•
2.125	1.078	3.219	1.062	DETROIT	7260	7260	1310	Y	5-353X <i>5-353X was replaced by 5-788X</i>
2.125	1.078	3.219	1.062	DETROIT	7260	7260	1310	N	5-634X <i>5-634X was replaced by 5-788X</i>
2.125	1.078	3.219	1.062	DETROIT	7260	7260	1310	N	5-647X• <i>Coated bearing caps</i>
2.125	1.078	3.219	1.062	DETROIT	7260	7260	1310	N	5-788X <i>Spicer Life Series</i>
2.125	1.078	3.220	1.062	DETROIT	7260	7260	1310/SPL22	N	SPL22-4X <i>SPL22-4X was replaced by 5-788X</i>
2.125	1.078	3.625	1.062	DETROIT	7260	7260	1330	Y	5-599X•
2.125	1.125	3.219	1.062	MECHANICS		2.5R	1310	Y	5-2530X <i>Plug in center of cross lube fitting not included</i>
2.344	1.000	3.219	1.062	SPICER		2R	1310	Y	5-2140X■
2.344	1.000	3.219	1.125	MECHANICS	2CL	2CL	1260	Y	5-2173X■
2.375	1.062	3.625	1.062	CLEVELAND	S55			Y	5-1202X■
2.556	1.125	3.219	1.062	SAGINAW	S44	S44	1310	Y	5-3022X
2.556	1.125	3.625	1.062	SAGINAW	S44	S44	1330/SPL25	N	SPL25-4X <i>SPL25-4X will be replaced by 5-7436X when supply is exhausted</i>
2.556	1.125	3.625	1.062	SAGINAW	S44	S44	1330/SPL25	N	SPL25-5X <i>SPL25-5X was replaced by SPL25-4X; Outside snap ring caps are coated</i>
2.556	1.125	3.625	1.062	SAGINAW	S44	S44	1330	Y	5-212X
2.556	1.125	3.625	1.062	SPICER	1330/S44			N	5-541X <i>5-541X was replaced by 5-793X</i>
2.556	1.125	3.625	1.062	SAGINAW	S44	S44	1330	N	5-619X <i>5-619X was replaced by 5-793X</i>

• Part is discontinued ■ Part is available until supply is exhausted ▲ Not sold separately

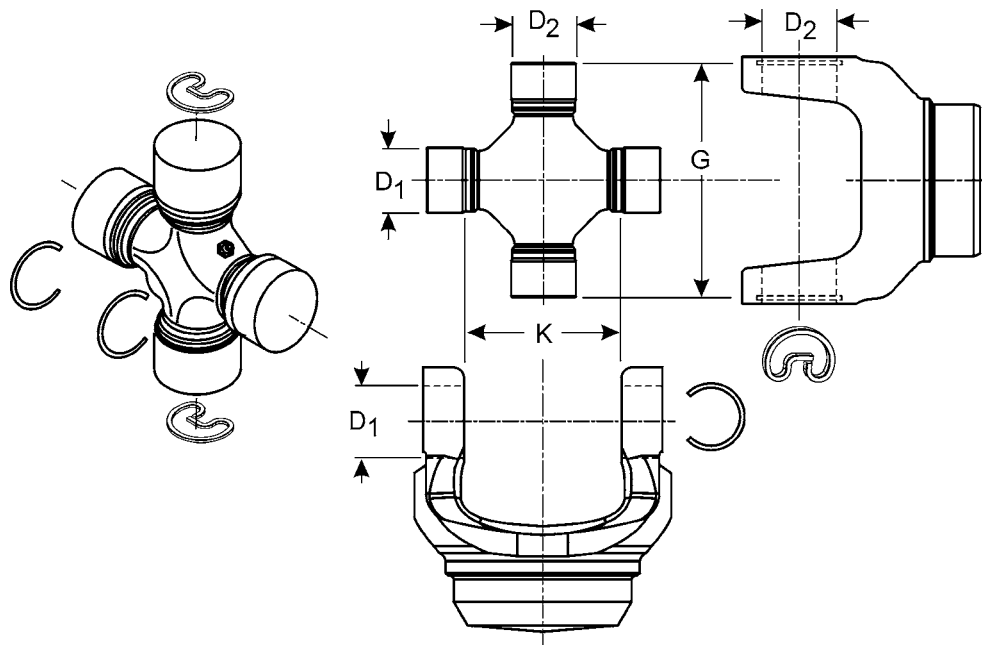

K	D1	G	D2	OE Mfg.	OE Series	Converts From this Series	To this Series Part	Greasable (Y=yes N=no)	Spicer Part Number
Inside Snap Ring Dimension	Inside Bearing cap Diameter	Outside Snap Ring Dimension	Outside Bearing cap Diameter						
2.556	1.125	3.625	1.062	SAGINAW	S44	S44	1330	N	5-621X <i>5-621X was replaced by 5-793X</i>
2.556	1.125	3.625	1.062	SPICER	1330/S44	S44	1330	N	5-793X <i>Spicer Life Series</i>
2.556	1.125	3.625	1.062	SAGINAW	S44	S44	1330	N	5-794X <i>5-794X was replaced by 5-793X; Outside snap ring caps are coated; Spicer Life Series</i>
2.556	1.125	3.625	1.062				1330		5003097
2.556	1.125	3.625	1.125	CLEVELAND	P55	S44	P55	Y	5-1312X•
2.556	1.125	3.625	1.188	SAGINAW	1350/S44	S44	1350	Y	5-3205X
2.625	1.125	3.219	1.062	DETROIT		7290	1310	Y	5-354X•
2.625	1.125	3.625	1.062	DETROIT	7290	7290	1330/SPL25	N	SPL25-7X <i>SPL25-7X was replaced by 5-7437X</i>
2.625	1.125	3.625	1.062	DETROIT	7290	7290	1330/SPL25	N	SPL25-8X <i>SPL25-8X was replaced by 5-7437X; Coated bearing caps</i>
2.625	1.125	3.625	1.062	DETROIT	7290	7290	1330	N	5-637X <i>5-637X was replaced by 5-7437X</i>
2.625	1.125	3.625	1.062	DETROIT	7290	7290	1330	N	5-672X <i>5-672X was replaced by 5-7437X</i>
2.625	1.125	3.625	1.062	DETROIT	7290	7290	1330	N	5-796X <i>5-796X was replaced by 5-7437X; Spicer Life Series</i>
2.767	1.062	3.625	1.125	SPICER		1330	1330SPEC	N	5-538X•
2.767	1.125	3.625	1.188	CLEVELAND	P55	1350	P55	Y	5-1313X•
3.000	1.231	4.188	1.188	DETROIT	5380	5380	1410	Y	5-357X

• Part is discontinued ■ Part is available until supply is exhausted ▲ Not sold separately

MSC

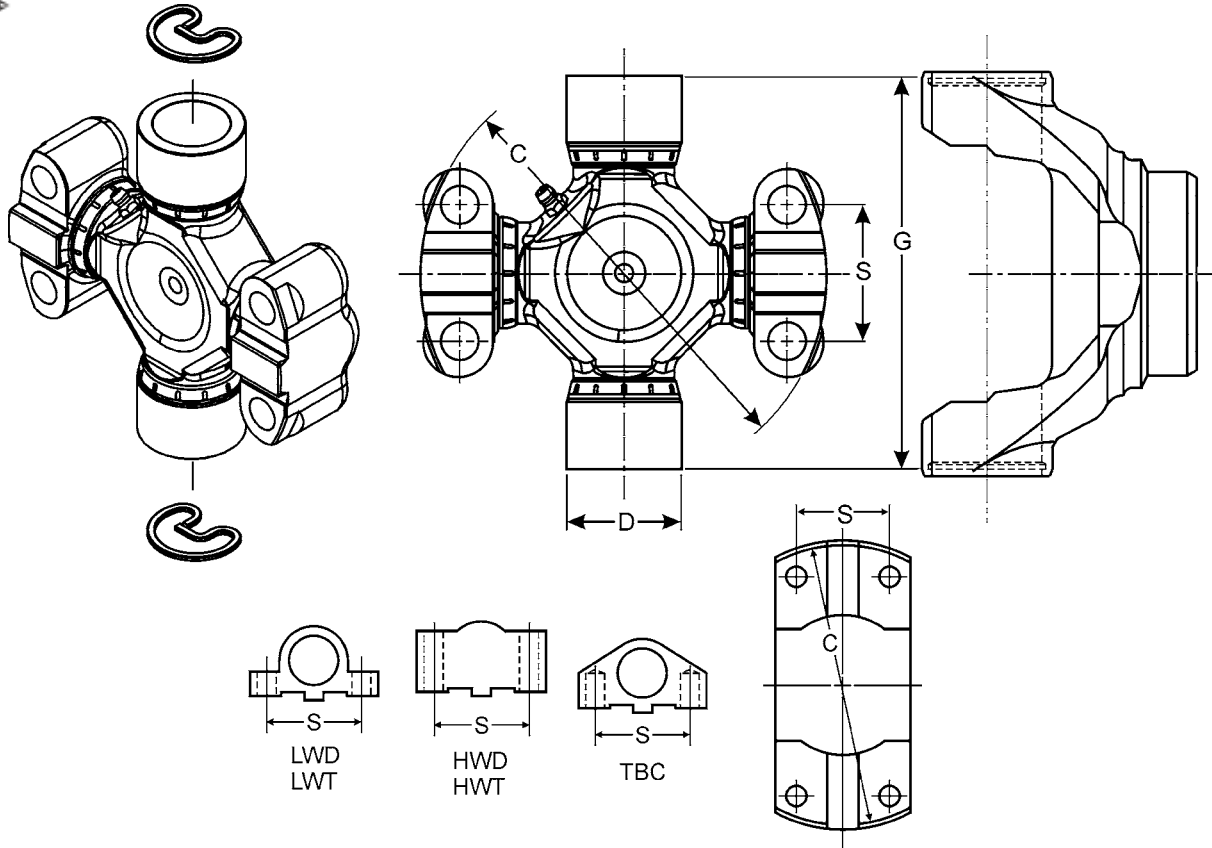

MSC

G Over Caps	D Bearing cap Diameter	C Pilot Diameter	S Between Bolt Holes	WB Cap Type	Converts From this Series	To this Series Part	Greasable (Y=yes N=no)	Spicer Part Number
3.219	1.062	3.125	1.312	TBC	2C	1310	Y	5-291X
3.219	1.062	3.562	1.438	TBC	3C	1310	Y	5-356X•
3.625	1.062	3.562	1.438	LWT	3C	1330/P55	Y	5-688X•
3.625	1.062	3.562	1.438	TBC	3C	1330	Y	5-314X•
3.625	1.188	3.562	1.438	LWT	3C	1350	Y	5-689X•
3.625	1.188	3.562	1.438	HWD	3C	1350	Y	5-698X•
4.188	1.188	4.250	1.438	HWD	4C	1410	Y	5-345X
4.188	1.188	4.250	1.438	LWT	4C	1410	Y	5-346X•
4.188	1.375	4.531	1.688	HWD	5C	1480	Y	5C-3X
4.188	1.375	4.531	1.688	HWT	5C	1480	Y	5C-5X
4.188	1.375	4.531	1.688	HWD	5C	1480	Y	5-347X
								<i>5-347X was replaced by 5C-3X</i>
4.188	1.375	4.531	1.688	HWT	5C	1480	Y	5-348X
								<i>5-348X was replaced by 5C-5X</i>
4.969	1.375	5.312	1.938	HWD	58WB	1550	Y	5-328X
4.969	1.375	5.312	1.938	LWT	58WB	1550	Y	5-693X•
4.969	1.375	5.312	1.938	HWT	58WB	1550	Y	5-329X•
4.969	1.375	5.531	1.688	HWD	6C/62N	1550	Y	5-221X
								<i>5-221X was replaced by 6C-3X</i>
4.969	1.375	5.531	1.688	HWD	6C/62N	1550	Y	6C-3X
4.969	1.375	5.531	1.688	HWT	6C/62N	1550	Y	6C-5X
4.969	1.375	5.531	1.688	HWT	6C/62N	1550	Y	5-220X
								<i>5-220X was replaced by 6C-5X</i>
5.594	1.625	5.844	1.938	HWT	7C/72N/68WB	1650	Y	5-331X•
5.594	1.625	5.844	1.938	HWD	7C/72N/68WB	1650	Y	5-330X
8.092	2.186	8.250	2.812	HWT	9C/92N/88WB	1850	Y	5-187X
8.092	2.186	8.250	2.812	HWD	9C/92N/88WB	1850	Y	5-186X•

• Part is discontinued ■ Part is available until supply is exhausted ▲ Not sold separately

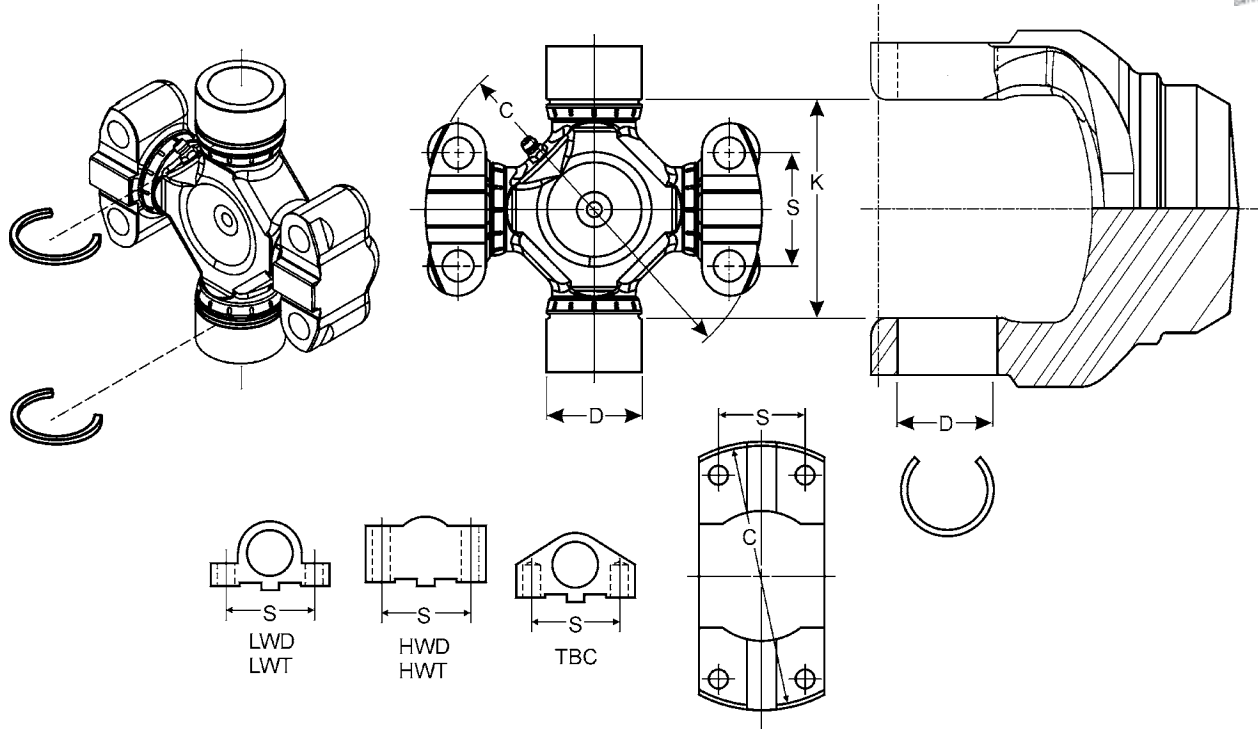

MSC

K	D	C	S	WB	Converts	To this	Greasable	Spicer Part
Between	Bearing cap	Pilot	Between	Cap	From this	Series	(Y=yes	Number
Snap Rings	Diameter	Diameter	Bolt Holes	Type	Series	Part	N=no)	
2.125	1.078	.000	1.750	LWD	7260	SPECIAL	Y	5-1304X•
2.344	1.000	3.125	1.312	LWD	2CRL	2R	Y	5-2033X
						<i>5-2033X was replaced by 050021000</i>		
2.344	1.000	3.125	1.312	TBC	2CRL	2R	Y	5-2031X
2.562	1.125	3.562	1.438	TBC	3CRL	S44	Y	5-3012X•
3.250	1.125	4.250	1.438	LWD	4CSRL	4R	Y	5-4016X•
3.250	1.125	4.250	1.438	LWT	4CRL	4D	Y	5-4014X
3.312	1.312	4.531	1.688	LWD	5CSRL	5R	Y	5-5015X
3.312	1.312	4.531	1.688	LWT	5CRL	5C	Y	5-5008X•

• Part is discontinued ■ Part is available until supply is exhausted ▲ Not sold separately

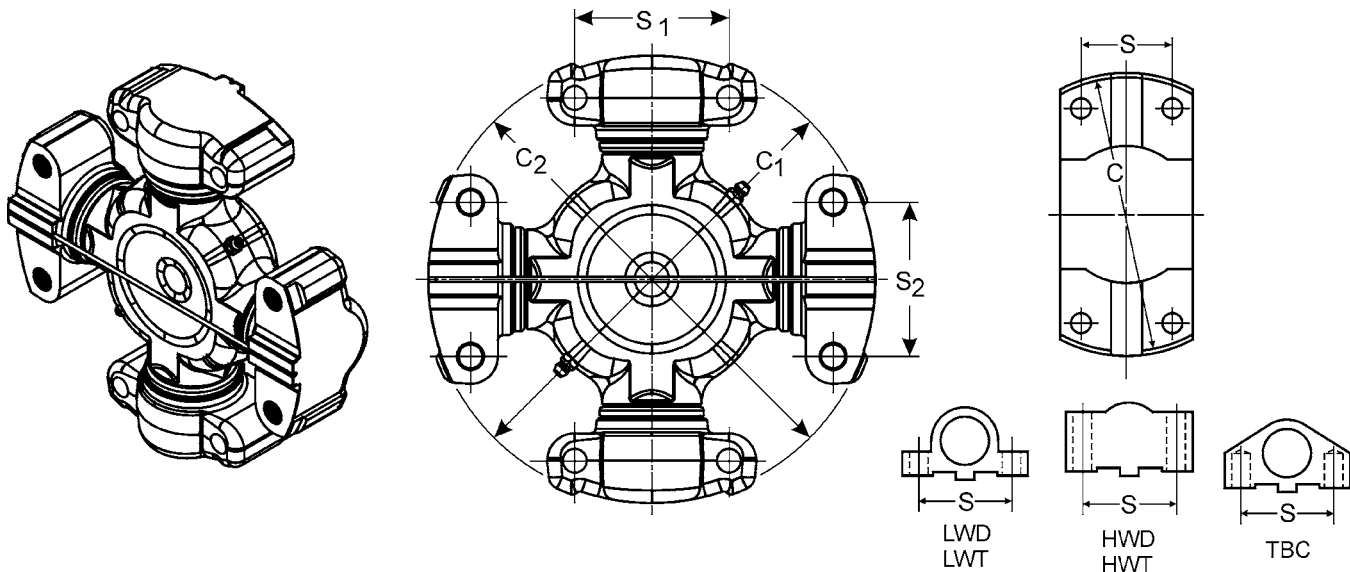

MSC

C1 Pilot Diameter	S1 Centerline to Centerline	WB (1) Cap Type	C2 Pilot Diameter	S2 Centerline to Centerline	WB (2) Cap Type	OE Manufacturer	Series	Greasable (Y=yes N=no)	Spicer Part Number
3.125	1.312	LWT	3.125	1.312	LWT	ITALCARDANO	2C	Y	5-781X <i>Lube fitting in brg cap</i>
3.125	1.312	LWD	3.125	1.312	LWD	ITALCARDANO	2C	N	050239000 <i>050239000 was replaced by 050239010</i>
3.125	1.312	LWD	3.125	1.312	LWD	ITALCARDANO	2C	Y	050239010 <i>Lube fitting in brg cap</i>
3.125	1.312	LWD	3.125	1.312	LWD	ITALCARDANO	2C	N	050238000•
3.125	1.312	LWD	3.125	2.387	TBC	MECHANICS	2C	Y	5-2116X•
3.125	1.312	TBC	3.125	1.312	TBC	MECHANICS	2C	Y	5-2002X
3.562	1.438	LWT	3.562	1.438	LWT	MECHANICS	3C	Y	5-3000X
4.250	1.438	HWD	4.250	1.438	HWD	ITALCARDANO	4C	Y	050742010 <i>Aftermarket Kit; Bolt part number 81530001, not included</i>
4.250	1.438	LWT	4.250	1.438	LWT	MECHANICS	4C	Y	5-4002X
4.250	1.438	HWD	4.250	1.438	HWD	MECHANICS	4C		5-4143X▪
4.250	1.438	HWD	4.250	1.438	HWT	MECHANICS	4C	Y	5-4140X
4.250	1.438	HWD	4.250	1.438	HWD	ITALCARDANO	4C	N	050742020 <i>OEM Kit; Bolt part number 81530001, not included</i>
4.250	1.438	HWD	4.250	1.438	HWD	ITALCARDANO	4C	Y	050742000 <i>OEM Kit; Bolt part number 81530001, not included</i>
4.531	1.688	HWD	4.531	1.688	HWD	MECHANICS	5C	Y	5C-1X•
4.531	1.688	HWD	4.531	1.688	HWD	ITALCARDANO	5C	Y	050776020 <i>OEM Kit; Bolt part number 81530007, not included</i>
4.531	1.688	HWD	4.531	1.688	HWD	ITALCARDANO	5C	Y	050776010 <i>Aftermarket Kit; Bolt part number 81530007, not included</i>
4.531	1.688	HWD	4.531	1.688	HWD	ITALCARDANO	5C	N	050370000 <i>OEM Kit; Bolt part number 81530007, not included</i>
4.531	1.688	LWD	4.531	1.688	LWT	MECHANICS	5C	Y	5-5121X
4.531	1.688	HWD	4.531	1.688	HWD	MECHANICS	5C	Y	5-5177X <i>5-5177X was replaced by 5C-1X</i>
4.531	1.688	TBC	4.531	1.688	LWT	MECHANICS	5C	Y	5-5000X▪
5.312	1.938	HWD	5.312	1.938	HWD	ROCKWELL	58WB	Y	5-5800X•
5.531	1.688	LWT	5.531	1.688	LWT	MECHANICS/ROCKWELL	6C/62N	Y	5-6000X
5.531	1.688	LWT	5.531	1.688	HWD	MECHANICS/ROCKWELL	6C/62N	Y	5-6102X <i>5-6102X was replaced by 6C-9X</i>

• Part is discontinued ■ Part is available until supply is exhausted ▲ Not sold separately
 Note: Bolts are not included with Italcadano joints unless noted; Contact manufacturer

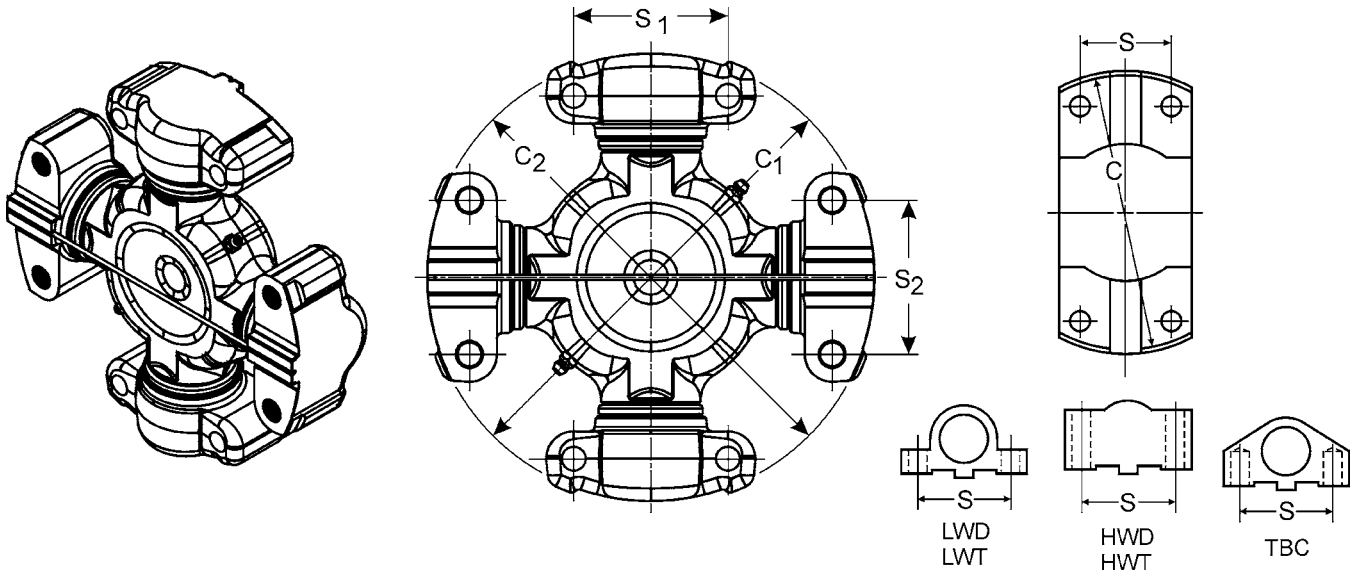

C1 Pilot Diameter	S1 Centerline to Centerline	WB (1) Cap Type	C2 Pilot Diameter	S2 Centerline to Centerline	WB (2) Cap Type	OE Manufacturer	Series	Greasable (Y=yes N=no)	Spicer Part Number
5.531	1.688	HWD	5.531	1.688	HWD	ITALCARDANO	6C/62N	Y	050380000
5.531	1.688	LWT	5.531	1.688	HWD	MECHANICS/ROCKWELL	6C/62N	Y	6C-9X•
5.531	1.688	HWD	5.531	1.688	HWD	MECHANICS/ROCKWELL	6C/62N	Y	5-6106X
<i>5-6106X was replaced by 050138000</i>									
5.531	1.688	HWD	5.531	1.688	HWD	ITALCARDANO	6C/62N	N	050273000
<i>Bolt part number 81530007, not included</i>									
5.531	1.688	HWD	5.531	1.688	HWD	ITALCARDANO	6C/62N	Y	050223000
5.531	1.688	HWD	5.531	1.688	HWD	ITALCARDANO	6C/62N	Y	050138010
<i>Bolt part number 81530007, not included</i>									
5.531	1.688	HWD	5.531	1.688	HWD	MECHANICS/ROCKWELL	6C/62N	Y	050138000
<i>OEM Kit; Bolt part number 81530007, not included</i>									
5.531	1.688	TBC	5.844	1.938	HWD	MECHANICS/ROCKWELL	6C/7C	Y	5-6109X•
5.531	1.688	TBC	5.844	1.938	TBC	MECHANICS/ROCKWELL	6C/7C	Y	5-6108X•
5.844	1.938	TBC	5.844	1.938	HWD	MECHANICS/ROCKWELL	7C/72N	Y	5-7202X
5.844	1.938	LWT	5.844	1.938	LWT	MECHANICS/ROCKWELL	7C/72N	Y	5-7000X
5.844	1.938	HWD	5.844	1.938	HWD	MECHANICS/ROCKWELL	7C/72N	Y	5-7105X
5.844	1.938	HWD	5.844	1.938	HWD	ITALCARDANO	7C/72N	N	050915222
5.844	1.938	HWD	5.844	1.938	HWD	ITALCARDANO	7C/72N	Y	050915010
<i>Aftermarket Kit; Bolt Part Number 81530014, not included</i>									
5.844	1.938	HWD	5.844	1.938	HWD	ITALCARDANO	7C/72N	Y	050915000
<i>OEM Kit; Bolt Part Number 81530014, not included</i>									
5.844	1.938	HWD	5.844	1.938	HWD	ITALCARDANO	7C/72N	N	050280000
<i>Bolt Part Number 81530014, not included</i>									
6.500	2.812	HWD	6.500	2.812	HWD	ITALCARDANO	8.5C	N	050281000
<i>Bolt Part Number 81530015, not included</i>									
6.500	2.812	LWD	6.500	2.812	LWD	ITALCARDANO	8.5C	Y	050964000
6.500	2.812	HWD	6.500	2.812	HWD	ITALCARDANO	8.5C	Y	050246000
<i>OEM Kit; Dual zerk in ctr of cross; Bolt# 81530015, not incl.</i>									
8.125	1.938	HWD	8.125	1.938	HWD	ITALCARDANO	8C/82N	Y	050509000
<i>050509000 was replaced by 050A62000; OEM Kit; Bolt Part Number 81530014, not included</i>									
8.125	1.938	TBC	8.125	1.938	HWD	MECHANICS/ROCKWELL	8C/82N	Y	5-8202X
8.125	1.938	HWD	8.125	1.938	HWD	MECHANICS/ROCKWELL	8C/82N	Y	5-8105X
8.125	1.938	HWD	8.125	1.938	HWD	ITALCARDANO	8C/82N	Y	050509010
<i>Aftermarket Kit; Bolt Part Number 81530014, not included</i>									

• Part is discontinued ■ Part is available until supply is exhausted ▲ Not sold separately
 Note: Bolts are not included with Italcadano joints unless noted; Contact manufacturer

MSC

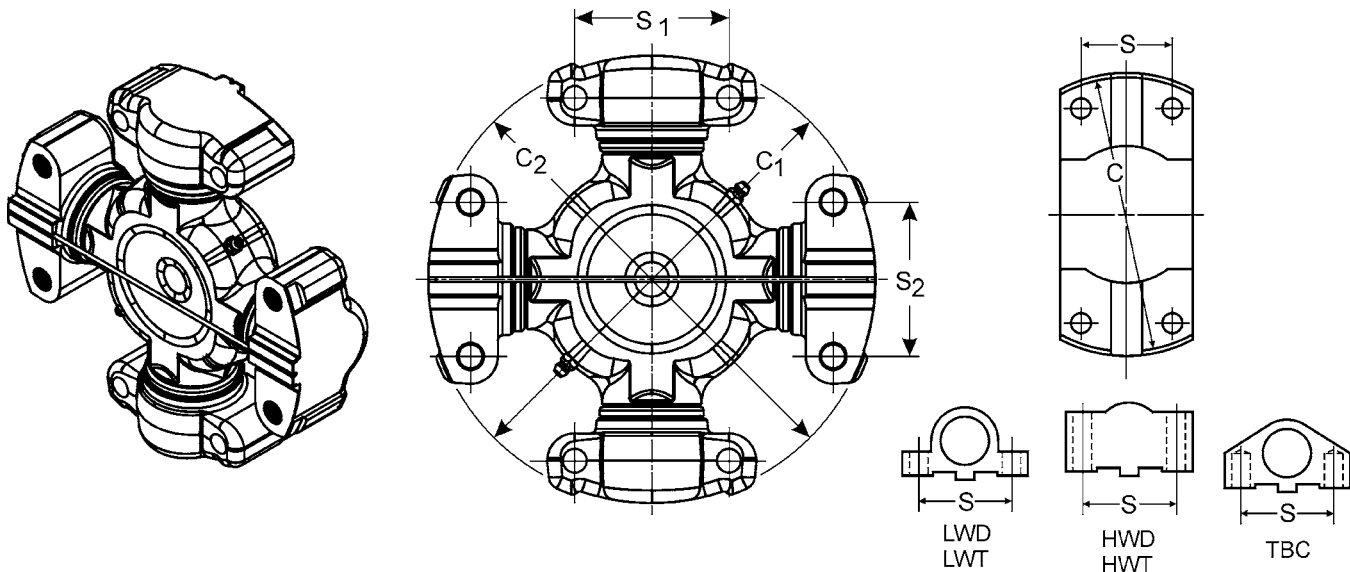

MSC

C1 Pilot Diameter	S1 Centerline to Centerline	WB (1) Cap Type	C2 Pilot Diameter	S2 Centerline to Centerline	WB (2) Cap Type	OE Manufacturer	Series	Greasable (Y=yes N=no)	Spicer Part Number
8.125	1.938	HWD	8.125	1.938	HWD	ITALCARDANO	8C/82N	N	050A64000 <i>OEM Kit; Bolt Part Number 815300014, not included</i>
8.125	1.938	LWT	8.125	1.938	LWT	MECHANICS/ROCKWELL	8C/82N	Y	5-8200X
8.250	2.812	HWD	8.250	2.812	HWD	MECHANICS/ROCKWELL	9C/92N	Y	5-9001X
8.250	2.812	HWD	8.250	2.812	HWD	MECHANICS/ROCKWELL	9C/92N	Y	5-643X (2) 45° zerks
8.250	2.812	HWT	8.250	2.812	HWD	MECHANICS/ROCKWELL	9C/92N	Y	5-9002X
8.250	2.812	HWT	8.250	2.812	HWT	MECHANICS/ROCKWELL	9C/92N	Y	5-9000X
8.250	2.812	HWD	8.250	2.812	HWD	ITALCARDANO	9C/92N	N	050427000 <i>OEM Kit; Bolt Part Number 815300015, not included</i>
8.250	2.812	HWD	8.250	2.812	HWD	ITALCARDANO	9C/92N	Y	050231000 <i>OEM Kit; Two zerks in cross; Bolt Part# 815300015, not incl</i>
8.374	3.626	HWD	8.374	3.626	HWD	ITALCARDANO	10C	Y	050242000 <i>OEM Kit; Two zerks in cross; Bolt Part# 815300017, not incl</i>
8.374	3.626	HWD	8.374	3.626	HWD	ITALCARDANO	10C	N	050417000 <i>050417000 was replaced by 050A53000</i>
8.374	3.626	HWD	8.374	3.626	HWD	ITALCARDANO	10C	N	050A53000 <i>OEM Kit; Bolt part # 815300017, not incl.</i>
8.374	3.626	HWD	8.374	3.626	HWD	ITALCARDANO	10C	Y	050A58000 <i>Two 45° zerks in cross</i>
8.750	3.500	HWD	8.750	3.500	HWD	TW DISC	J490	Y	5-10490X
8.750	3.500	HWD	8.750	3.500	HWD	ITALCARDANO	11C	Y	050435000 <i>050435000 was replaced by 050A55000; Has two zerks in cross</i>
8.750	3.500	HWD	8.750	3.500	HWD	ITALCARDANO	11C	N	050A56000 <i>OEM Kit; Bolt part # 815300004, not incl.</i>
8.750	3.500	HWD	8.750	3.500	HWD	ITALCARDANO	11C	Y	050A55000 <i>OEM Kit; Bolt part # 815300004, not incl.</i>
9.685	3.228	HWD	9.685	3.228	HWD	ITALCARDANO	246-M210	Y	050781200 <i>Has two zerks in cross; includes bolts</i>
10.235	3.936	HWD	10.235	3.936	HWD	ITALCARDANO	15C	Y	050523001 <i>Has two zerks in cross; OEM kit</i>
11.024	3.622	HWD	11.024	3.622	HWD	ITALCARDANO	12.5C	Y	050518000 <i>OEM Kit; Two zerks in cross; Bolt Part# 81518001, not incl.</i>

• Part is discontinued ■ Part is available until supply is exhausted ▲ Not sold separately
 Note: Bolts are not included with Italcadano joints unless noted; Contact manufacturer

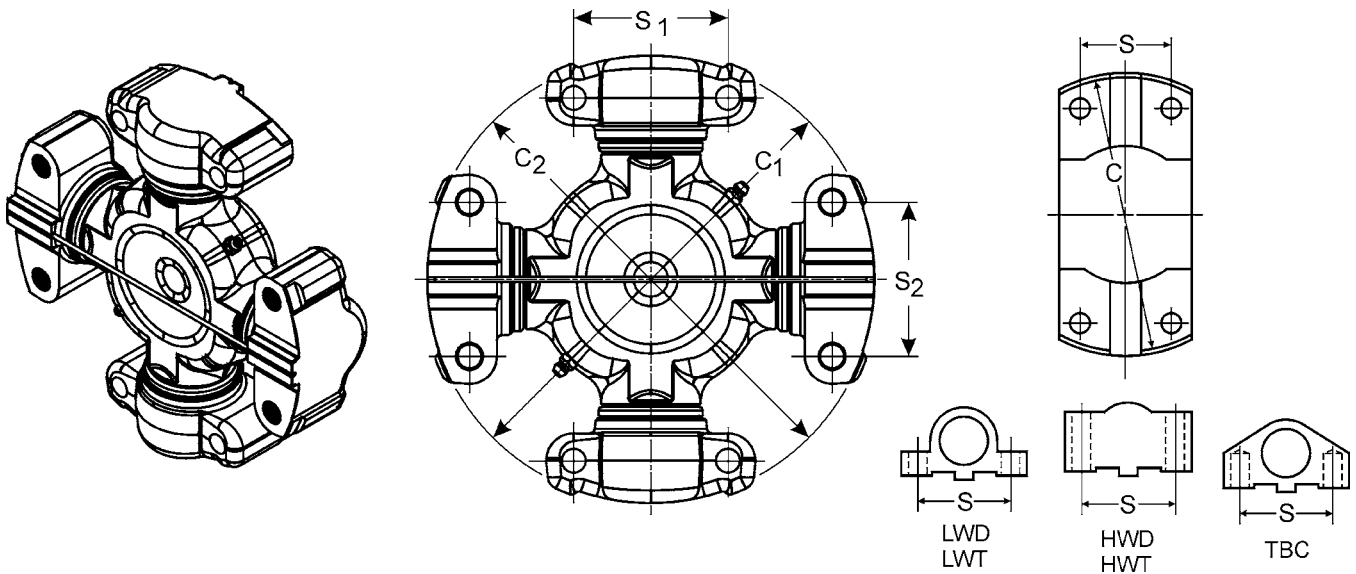

C1 Pilot Diameter	S1 Centerline to Centerline	WB (1) Cap Type	C2 Pilot Diameter	S2 Centerline to Centerline	WB (2) Cap Type	OE Manufacturer	Series	Greasable (Y=yes N=no)	Spicer Part Number
11.374	3.326	HWD	11.374	3.626	HWD	SPICER ITALCARDANO	12C	Y	050A89000 <i>Low temp grease ; Bolt# 815180001 not incl.</i>
11.374	3.626	HWD	11.374	3.626	HWD	ITALCARDANO	12C	Y	050A54000 <i>Has two zerks in cross; OEM Kit; Bolt# 815180001, not incl.</i>
11.374	3.626	HWD	11.374	3.626	HWD	ITALCARDANO	12C	N	050111000 <i>OEM Kit; Bolt part # 815180001, not incl.</i>
11.374	3.626	HWD	11.374	3.626	HWD	ITALCARDANO	12C	Y	050A68000 <i>Two 90° zerks in cross; OEM kit; bolt# 815180001, not incl.</i>
12.204	4.213	HWD	12.204	4.213	HWD	ITALCARDANO	14.5C	N	050421000 <i>OEM Kit</i>
13.339	5.310	HWD	13.339	5.310	HWD	ITALCARDANO	14C	N	050101000 <i>Bolt Part Number 814930001, not included</i>
13.339	5.310	HWD	13.339	5.310	HWD	ITALCARDANO	14C	Y	050A51000 <i>OEM Kit; Dual zerk in ctr of cross; Bolt# 814930001, not incl.</i>
13.339	5.310	HWD	13.339	5.310	HWD	SPICER ITALCARDANO	14C	Y	050A85000 <i>Bolt# 814930001 not incl.; zerk in ctr of cross; Low temp grease</i>

MSC

• Part is discontinued ■ Part is available until supply is exhausted ▲ Not sold separately
 Note: Bolts are not included with Italcadano joints unless noted; Contact manufacturer

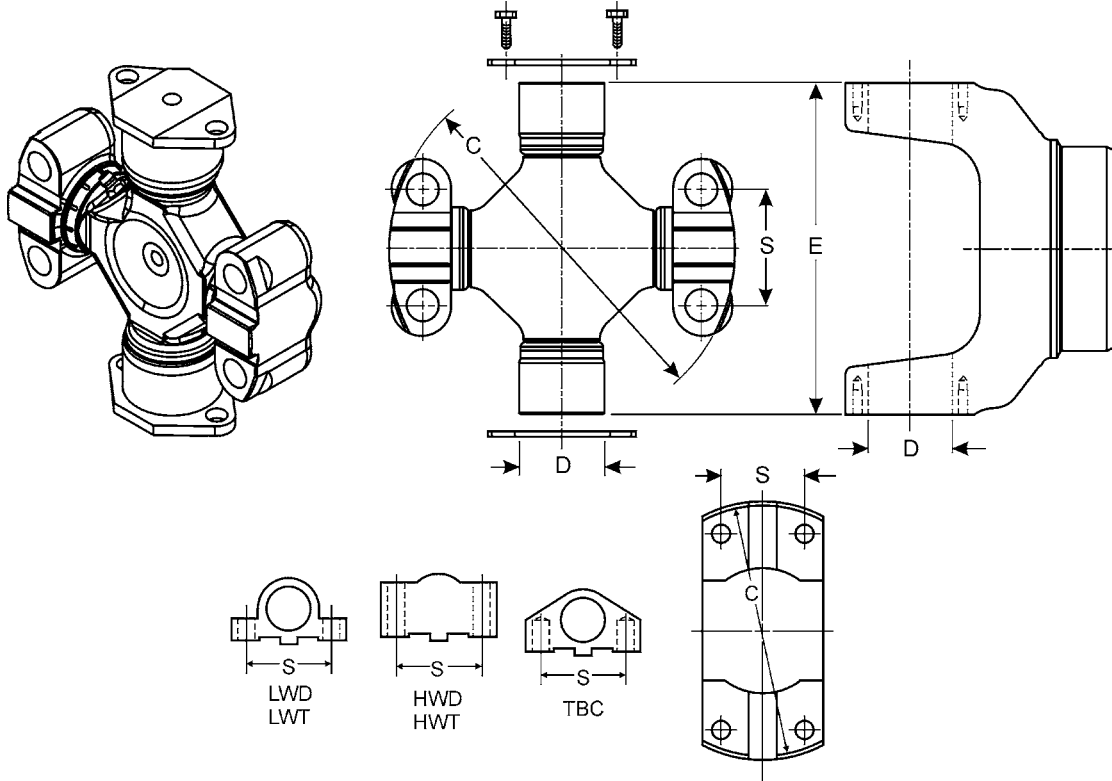

MSC

E	D	C	S	WB Cap Type	Converts From this Series	To this Series Part	Greasable (Y=yes N=no)	Spicer Part Number
Between Caps	Bearing cap Diameter	Pilot Diameter	Between Holes					
5.312	1.875	5.606	2.400	HWD	BRADLEY	1610 <i>Bradley Military Vehicle (PAINTED)</i>	Y	5012401
5.312	1.875	5.606	2.400	HWD	BRADLEY	1610 <i>Bradley Military Vehicle</i>	Y	5-450X
6.094	1.938	6.375	2.438	HWD	1710	J210	Y	5-705X•
6.094	1.938	6.500	2.812	HWD	1710	8.5C/85WB	Y	5-704X•
7.547	1.938	8.250	2.812	HWD	1810	9C/92N	Y	5-324X
7.547	1.938	8.250	2.812	HWD	1810	9C/92N	Y	5-727X
7.547	1.938	8.250	2.812	LWT	1810	9C/92N	Y	5-696X•
8.094	2.188	8.250	2.812	HWT	1880	9C/92N	Y	5-327X
8.094	2.188	8.250	2.812	HWD	1880	9C/92N	Y	5-642X (2) 45° zerks
8.094	2.188	8.250	2.812	HWD	1880	9C/92N	Y	5-326X

• Part is discontinued ■ Part is available until supply is exhausted ▲ Not sold separately

Spicer Life Series™ (SPL) (Spring Tab Style)

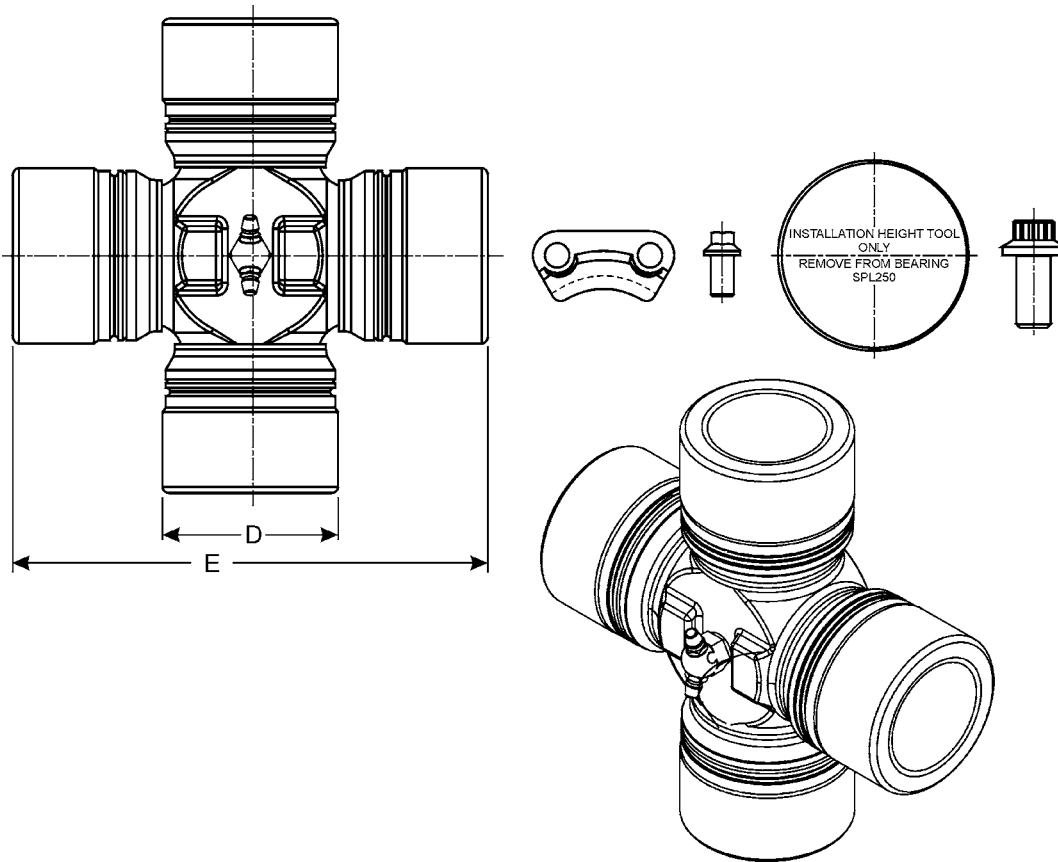

MSC

E Over Caps (mm)	E Over Caps (std)	D Bearing cap Diameter (mm)	D Bearing cap Diameter (std)	OE Series	Spicer OE Series	Greasable (Y=yes N=no)	Spicer Part Number
138.71	5.461	49.20	1.937	SPICER	SPL140	Y	SPL140X
164.00	6.456	55.00	2.165	SPICER	SPL170	Y	SPL170-3X
164.00	6.456	55.00	2.165	SPICER	SPL170	Y	SPL170X <i>SPL170X was replaced by SPL170-3X</i>
163.00	.000	60.00	.000	SPICER	SPL250	--	SPL250-3X
163.00	.000	60.00	.000	SPICER	SPL250	--	SPL250X <i>SPL250X was replaced by SPL250-3X</i>

• Part is discontinued ■ Part is available until supply is exhausted ▲ Not sold separately

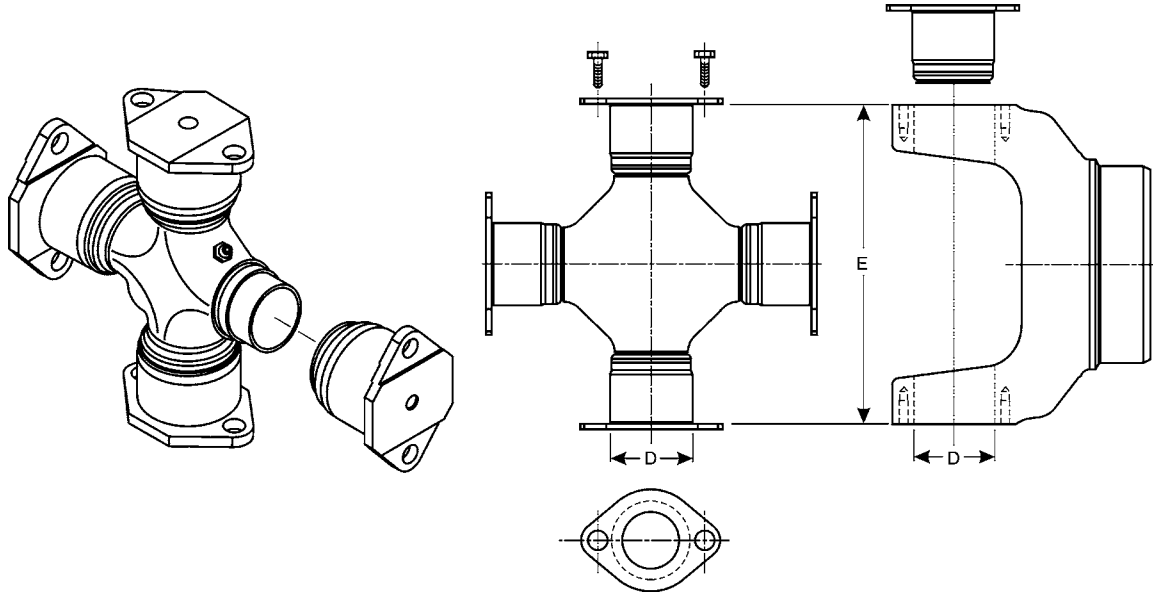

E Between Caps	D Bearing cap Diameter	OE Mfg.	OE Series	Greasable (Y=yes N=no)	Spicer Part Number
4.562	1.562	SPICER	1500	Y	5-115X•
5.312	1.875	SPICER	1610	Y	5-279X
6.094	1.938	SPICER	1710	Y	5-280-4X•
					<i>Four lube fittings in journal</i>
6.094	1.938	SPICER	1710	Y	5-280X
6.594	2.312	SPICER	1800	Y	5-124X•
7.000	1.938	SPICER	1760	Y	5-407X
7.547	1.938	SPICER	1810	Y	5-281X
7.547	1.938	SPICER	1810	Y	5-281-4X•
					<i>Has four zerks in cross</i>
8.094	2.188	SPICER	1880		5-308X
8.781	2.812	SPICER	1900	Y	5-54X•
					<i>Has four bolt holes in bearing plate</i>

• Part is discontinued ■ Part is available until supply is exhausted ▲ Not sold separately

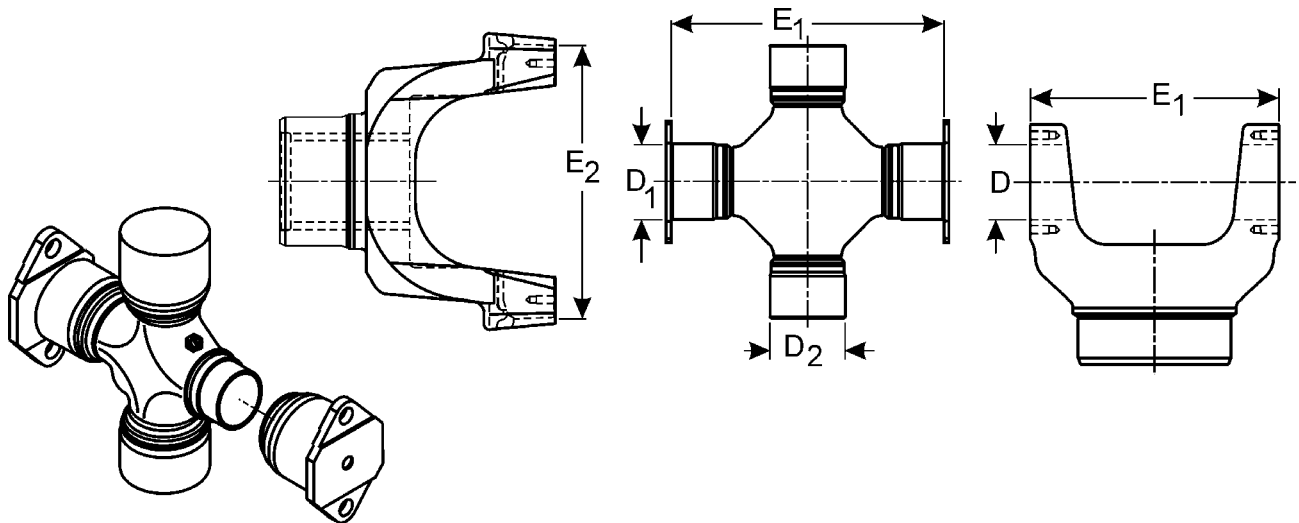

E1 Between Caps	D1 Bearing cap Diameter	E2 Over Bearing Caps	D2 Bearing cap Diameter	OE Mfg	OE Series	Greasable (Y=yes N=no)	Spicer Part Number
5.312	1.875	5.312	1.875	SPICER	1610	Y	5-674X <i>Includes strap kit</i>
5.312	1.875	5.312	1.875	SPICER	1610	N	5001247 <i>Has (2) plugs in place of the zerks</i>
5.312	1.875	5.312	1.875	SPICER	1610	N	5-610X
5.312	1.875	5.312	1.875	SPICER	1610	Y	5-777X <i>Same as 5-674X w/out strap kit</i>
5.312	1.875	5.312	1.875	SPICER	1610	Y	5-585XM <i>Metric bolts w/lock strap; Grease zerk in center of cross</i>
5.312	1.875	5.312	1.875	SPICER	1610	Y	5-438X <i>5-438X was replaced by 5-674X</i>
5.312	1.875	5.312	1.875	SPICER	1610	Y	5-423X <i>Grease zerk in center of cross</i>
6.094	1.938	6.094	1.938	SPICER	1710	Y	5-746X <i>Includes metric bolts used on bearing cap</i>
6.094	1.938	6.094	1.938	SPICER	1710	Y	5-773X <i>Same as 5-675X but uses/includes strap with metric bolts</i>
6.094	1.938	6.094	1.938	SPICER	1710	Y	5-671X <i>Thrustwashers in bearing cap</i>
6.094	1.938	6.094	1.938	SPICER	1710	Y	5-675X <i>Includes strap kit</i>
6.094	1.938	6.094	1.938	SPICER	1710	Y	5-515X <i>5-515X was replaced by 5-675X</i>
7.000	1.938	7.000	1.938	SPICER	1760	Y	5-469X <i>5-469X was replaced by 5-677X</i>
7.000	1.938	7.000	1.938	SPICER	1760	Y	5-677X <i>Includes strap kit</i>
7.547	1.938	5.547	1.938	SPICER	1810	Y	5-510X <i>5-510X was replaced by 5-676X</i>
7.547	1.938	7.547	1.938	SPICER	1810	Y	5-676X <i>Includes strap kit</i>

• Part is discontinued ■ Part is available until supply is exhausted ▲ Not sold separately

MSC

Without Body

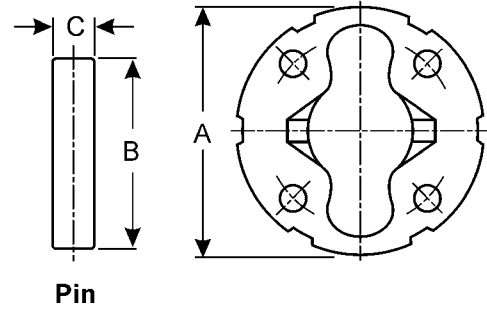
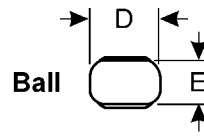
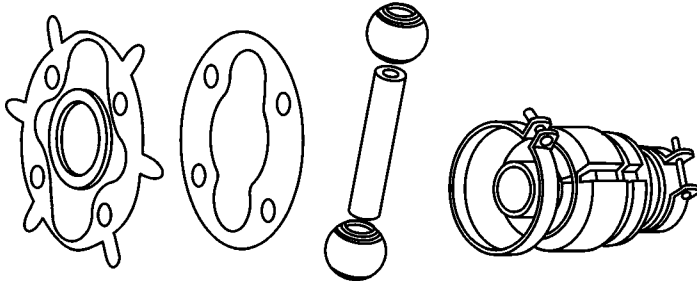

MSC

A Flange Diameter	B Pin Length	C Pin Diameter	D Ball Diameter	E Ball Thickness	Spicer Part Number
3.625	2.969	.562	1.031	.609	5-1407X•
4.000	2.875	.562	1.031	.609	5-1405X•

• Part is discontinued ■ Part is available until supply is exhausted ▲ Not sold separately

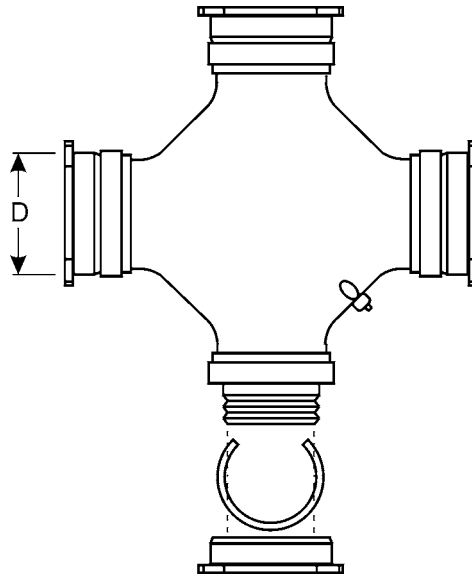

MSC

Over Caps	D	Thread Size	OE Series	Greaseable (Y=yes N=no)	Spicer Part Number
	Bearing cap Diameter				
2.934	1.125	.938-20	CHEV	Y	5-3031X

• Part is discontinued ■ Part is available until supply is exhausted ▲ Not sold separately

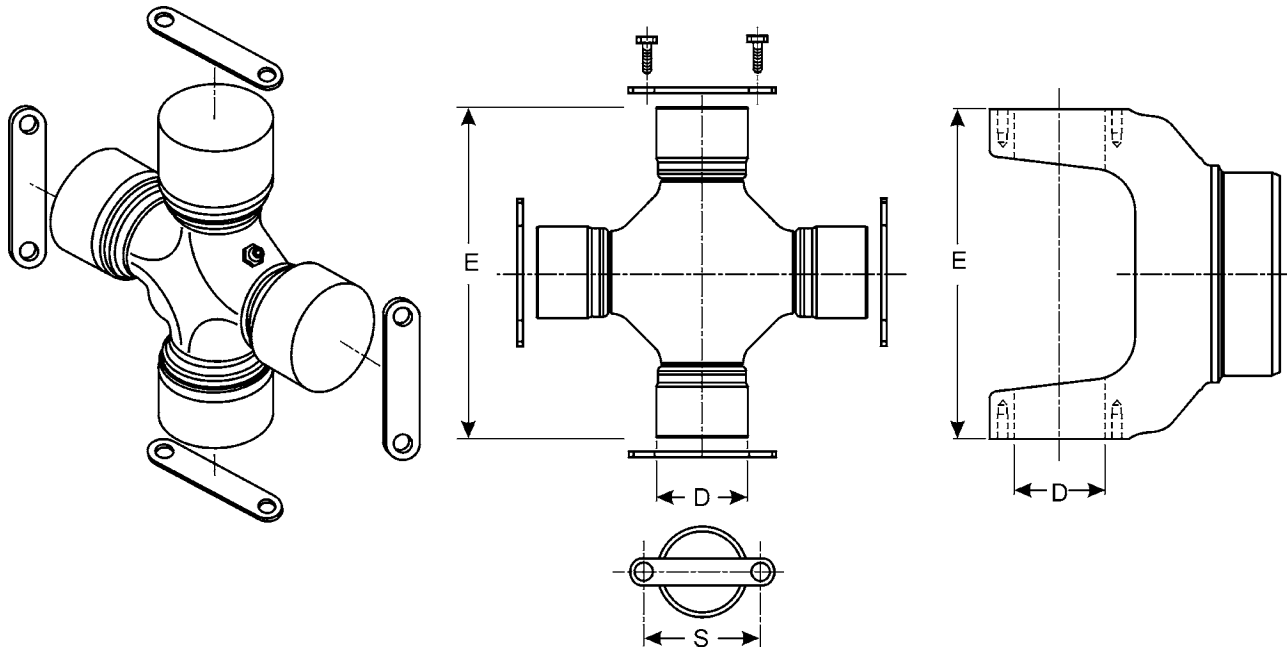

MSC

E	D1	S	OE Mfg.	OE Series	Greasable (Y=yes N=no)	Spicer Part Number
Over Caps	Bearing cap Diameter	Bolt Hole C-Line to C-Line				
4.188	1.375	1.750	CLEVELAND	D56	Y	5-1214X• <i>Bearing plates not supplied with kit</i>

• Part is discontinued ■ Part is available until supply is exhausted ▲ Not sold separately

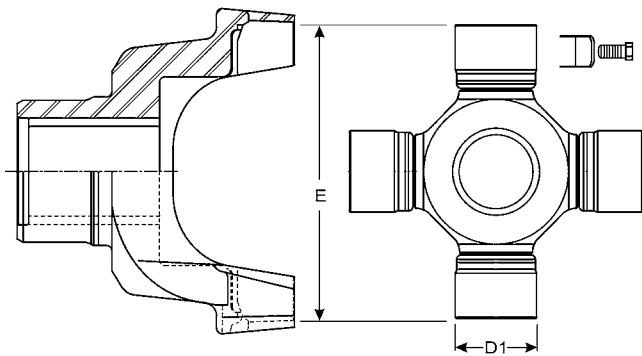

Figure 1

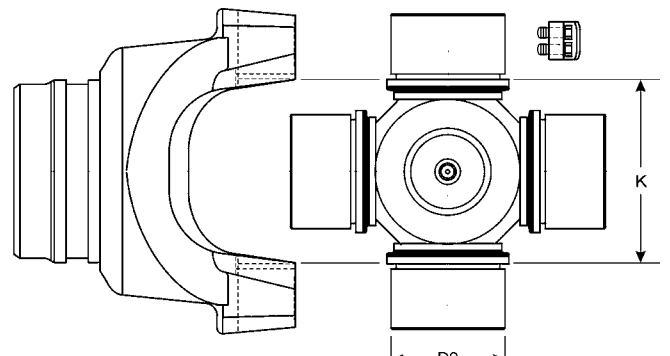
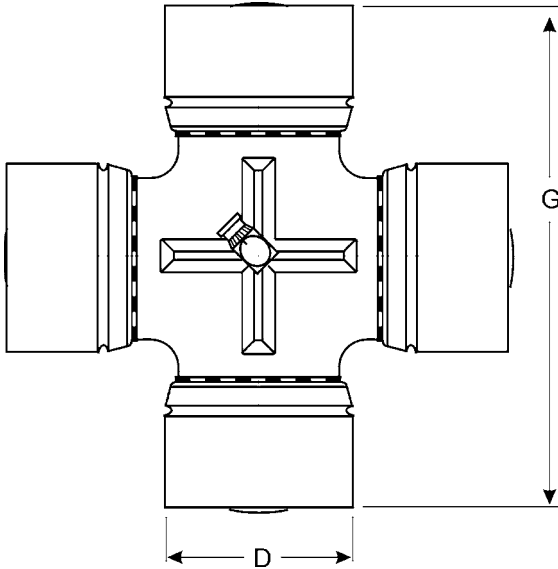

Figure 2

Figure 1		Figure 2		OE Series	Spicer OE Series	Greaseable (Y=yes N=no)	Spicer Part Number
E Over Caps	D1 Bearing cap Diameter	K Between Snap Rings	D2 Bearing cap Diameter				
—	—	5.665	2.565	SPICER	1910	Y	5-316X•
10.046	3.062	—	—	SPICER	1950	Y	5-339X•
12.343	3.812	—	—	SPICER	2050	Y	5-340X•

• Part is discontinued ■ Part is available until supply is exhausted ▲ Not sold separately

MSC



MSC

G Over Caps	D Bearing cap Diameter	OE Mfg.	OE Series
1.614	.591	SPICER GWB	473.10
1.937	.748	SPICER GWB	473.20
1.976	.866	SPICER GWB	373.20
2.323	.866	SPICER GWB	473.30
2.409	.937	SPICER GWB	687.10
2.748	1.024	SPICER GWB	287.00
2.933	1.063	SPICER GWB	687.15
3.220	1.181	SPICER GWB	287.10
3.220	1.189	SPICER GWB	687.20
3.622	1.374	SPICER GWB	687.25
3.811	1.378	SPICER GWB	287.20
3.811	1.378	SPICER GWB	587.10
4.114	1.654	SPICER GWB	587.15
4.165	1.496	SPICER GWB	387.20
4.198	1.374	SPICER GWB	687.30

G Over Caps	D Bearing cap Diameter	OE Mfg.	OE Series
4.587	1.890	SPICER GWB	587.20
4.701	1.654	SPICER GWB	687.35
4.913	1.732	SPICER GWB	287.30
5.236	2.047	SPICER GWB	587.30
5.322	1.874	SPICER GWB	687.40
5.669	2.244	SPICER GWB	587.35
5.745	2.047	SPICER GWB	687.45
5.984	2.244	SPICER GWB	687.55
5.987	2.244	SPICER GWB	587.42
6.024	1.969	SPICER GWB	287.40
6.457	2.165	SPICER GWB	387.40
6.602	2.323	SPICER GWB	687.60
6.772	2.559	SPICER GWB	687.65
6.772	2.559	SPICER GWB	587.48
7.283	2.835	SPICER GWB	587.50
8.534	2.913	SPICER GWB	587.55
9.110	3.267	SPICER GWB	587.60

• Part is discontinued ■ Part is available until supply is exhausted ▲ Not sold separately

Note: For reference only; these u-joint kits are not serviced by Dana Spicer Service Parts. These service u-joint kits can be obtained by contacting Dana Driveshaft Products Group, Products of Spicer Gelenkwellenbau, (419) 866-2621.

Obsolete Part Number	Series / Model	Status	Replaced By (where applicable)	Obsolete Part Number	Series / Model	Status	Replaced By (where applicable)
50239000	2C	Superseded	050239010	5-546X	1550	Obsolete	No Replacement
050435000	11C	Superseded	050A55000	5-599X	1330/7260	Obsolete	No Replacement
050509000	8C	Superseded	050A62000	5-6102X	6C	Superseded	No Replacement
5-111X	1100	Superseded	5-101X	5-611-1X	1310	Obsolete	No Replacement
5-1200X	1310	Superseded	5-153X	5-626X	1310	Superseded	5-3613X
5-1201X	S55	Superseded	5-7439X	5-634X	1310/7260	Superseded	5-788X
5-1205X	R55	Obsolete	No Replacement	5-641X	1410	Superseded	5-1410X
5-1206X	1410	Superseded	5004989	5-647X	1310/7260	Obsolete	No Replacement
5-124X	1800	Obsolete	No Replacement	5-722X	1410	Superseded	5-1410X
5-1306X	7260	Superseded	5-789X	5-726X	1410	Superseded	5-1410X
5-174X	1350	Superseded	5-178X	5-739X	1410	Superseded	5-1410-1X
5-185X	1850	Obsolete	No Replacement	5-744X	1330	Superseded	5-7436X
5-2011X	2R	Obsolete	No Replacement	5-749X	1330/7290	Superseded	5-7437X
5-220X	1550/6C	Superseded	6C-5X	5-74X	1310	Superseded	5-260X
5-255X	1310	Superseded	5-1310-1X	5-754X	1330	Superseded	5-811X
5-260-1X	1310	Superseded	5-260X	5-755X	1000	Obsolete	No Replacement
5-263X	1480	Superseded	SPL55-1X	5-761X	1410/4C	Superseded	5-345X
5-273X	1330	Superseded	5-1330-1X	5-774X	9300	Superseded	5-781X
5-275X	1550	Superseded	SPL70-1X	5-785X	1310	Superseded	5-1310X
5-278X	1310	Superseded	5-1310-1X	5-786X	1310	Superseded	5-3613X
5-282X	1350	Superseded	5-1350X	5-787X	1310 SPEC	Superseded	5-7439X
5-297-1X	1310	Superseded	5-760X	5-790X	1330	Superseded	5-1330X
5-319X	1480	Superseded	SPL55-1X	5-791X	1330 ALUM	Superseded	5-3614X
5-332X	1480	Superseded	SPL55-3X	5-792X	1330	Superseded	5-7438X
5-350X	1310	Obsolete	No Replacement	5-796X	1330/7290	Superseded	5-7437X
5-354X	1310/7290	Obsolete	No Replacement	5-797X	SPL25	Superseded	5-7437X
5-432X	55N	Obsolete	No Replacement	5-799X	1350	Superseded	5-1350X
5-433-1X	1310	Superseded	5-1310-1X	5-801X	1410	Superseded	5-1410X
5-447X	1350	Superseded	5-3615X	5-802X	1410	Superseded	5-3616X
5-462X	1410	Superseded	5-1410-1X	5-803X	1480	Superseded	SPL55X
5-471X	1350	Superseded	5-1350-1X	5-804X	1480	Superseded	SPL55-1X
5-481X	1410	Superseded	5-160X	5-806X	1480 WJ	Superseded	SPL55-3X
5-482X	1480	Superseded	5-188X	5-807X	1480 WJ	Superseded	SPL55-4X
5-483X	1550	Superseded	5-155X	5-808X	1550	Superseded	SPL70X
5-4X	1300	Obsolete	No Replacement	5-809X	1550	Superseded	SPL70-1X
5-5000X	5C	Obsolete	No Replacement	5-810X	1310	Superseded	5-1310-1X
5-5177X	5C	Superseded	050776020	5-812X	1330	Superseded	5-1330-1X
5-526X	1210	Superseded	5-443X	5-86X	1350	Superseded	5-1350X
5-527X	7260-7290	Obsolete	No Replacement	5-88X	1480	Superseded	SPL55-3X
5-538X	1330 SPEC	Obsolete	No Replacement	5C-1X	5C	Obsolete	050776020
5-542X	1350	Superseded	5-1350-1X	6C-1X	6C	Superseded	050138000
5-544X	1310/3R	Obsolete	No Replacement	SPL170X	SPL170	Superseded	SPL170-4X

Obsolete Part Number	Series / Model	Status	Replaced By (where applicable)
SPL170-3X	SPL170	Superseded	SPL170-4X
SPL22-1X	SPL22	Superseded	5-1310X
SPL22-2X	SPL22	Superseded	5-3613X
SPL22-3X	SPL22	Superseded	5-7439X
SPL22-7X	SPL22	Superseded	5-1310-1X
SPL250X	SPL250	Superseded	SPL250-3X
SPL25-1X	SPL25	Superseded	5-1330X
SPL25-2X	SPL25	Superseded	5-3614X
SPL25-3X	SPL25	Superseded	5-7438X
SPL25-4X	SPL25	Superseded	5-7436X
SPL25-7X	SPL25	Superseded	5-7437X
SPL30-1X	SPL30	Superseded	5-1350X
SPL30-2X	SPL30	Superseded	5-3615X
SPL30-3X	SPL30	Obsolete	No Replacement
SPL36-1X	SPL36	Superseded	5-1410X
SPL36-2X	SPL36	Superseded	5-3616X
SPL70-3X	SPL70-WJ	Superseded	SPL70-4X
SPL90X	SPL90	Superseded	SPL100-1X

SPICER®

DRIVETRAIN COMPONENTS



Genuine Spicer®

Bearing Strap and U-Bolt Kits

**The parts you need.
The name you trust.**

Spicer U-joints and end yokes deliver top performance and value—count on Spicer bearing strap and U-bolt kits to keep it all together. These strap and U-bolt kits are manufactured to the same high standards you've come to expect from the most reliable name in driveshaft parts.



SPICER®

DRIVETRAIN COMPONENTS

Dana Holding Corporation
Aftermarket Group
PO Box 321
Toledo, Ohio 43697-0321

Phone: 1-800-SAY-DANA (729-3262)

www.spicerparts.com

