

# Installation and Operation

## **UAS™ 7000**

---

Network/Dropside Interface Unit  
Model NIU/DIU 7624



# NIU/DIU 7624

## Table of Contents

---

|  |    |
|--|----|
| NIU/DIU 7624 .....                             | 1  |
| Features.....                                  | 1  |
| Options.....                                   | 3  |
| Installing the NIU/DIU 7624 .....              | 5  |
| Cabling the 7624.....                          | 6  |
| Mixing Cards in The UAS Shelf .....            | 6  |
| 50-Pin Telco Mapping .....                     | 7  |
| DB-25 Zone 3 Pinouts.....                      | 8  |
| Front Panel Indicators .....                   | 9  |
| Tests .....                                    | 10 |
| T1 Line Loopback .....                         | 10 |
| T1 Payload Loopback.....                       | 10 |
| Self Test.....                                 | 10 |
| Digital Loopback.....                          | 11 |
| Remote Digital Loopback.....                   | 11 |
| Remote Digital Loopback with Self Test .....   | 11 |
| Remote Bilateral Loopback .....                | 12 |
| Remote Bilateral Loopback with Self Test ..... | 12 |
| Master to Remote Self Test .....               | 12 |
| Remote to Remote Self Test.....                | 13 |
| Parts List and Specifications .....            | 14 |



# NIU/DIU 7624

## NIU/DIU 7624

The UAS NIU/DIU 7624 multiplexes 12 IDSL (ISDN DSL) interfaces into a single T1. This dual-slot card provides the same function as one NIU 7001 and four DIU 7616ML's, and increases the capacity of a dual UAS 7000 shelf nearly four times. For example: a dual UAS 7000 shelf can accommodate fourteen managed T1s. Four shelves accommodate 28 T1s or 1 DS-3 worth of bandwidth in 28" of rack space. A 7-foot high rack can accommodate 2 DS-3 payloads or 56 T1s. It allows service providers to utilize the entire T1 bandwidth when offering IDSL (128k) service. The UAS 7624 fits into the UAS 7000 shelf and is controlled by the TEAM 7624 for UNIX Manager, by Local Management VT-100 or Telnet, or by hard configuration via DIP switches.

### Features

#### NIU:

- DSX-1 (per ANSI T1.102) or DS1 (per ANSI T1.403) operation.
- ESF or SF framing.
- B8ZS or AMI Line Coding.
- DSX-1 Pre-Equalization: 0-655 ft. in 130 ft. increments.
- DS1 Line Build Out: 0, -7.5, -15, or -22 dB.
- FDL messaging: ANSI T1.403 or Bellcore TR54016.
- Configuration via SNMP commands using the SNMP GDC SCM card, via Telnet using VT100 connected to craft port of SCM card, or via hardware DIP switch settings.
- Fixed DSL to T1 DS0 mapping (for example: DSL 1 to DS0 1 and 2, DSL 2 to DS0 3 and 4, etc.)
- Selectable Payload or Line Loopbacks
- Performance monitoring per ANSI T1.403 and Bellcore TR54016.
- Selectable Recovered or Internal Transmit Timing.
- Selectable AIS Loop Down: Inhibit or 5-60 seconds in 1 second increments.

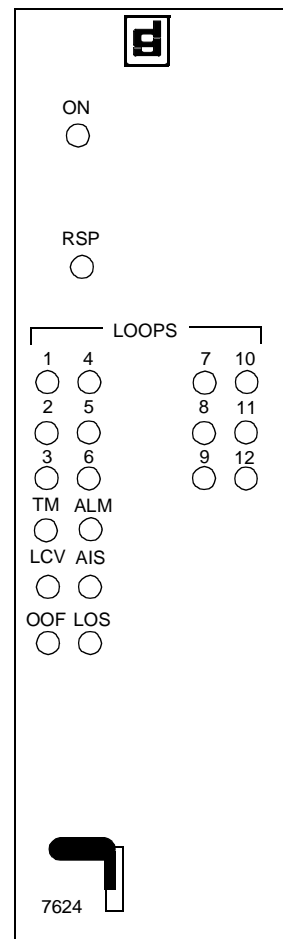

**DIU:**

- Twelve (2B1Q U-Interface) IDSL's per ANSI T1.601.
- Management of GDC's DataComm 610/612/621 modems using the EOC (Embedded Operations Channel).
- LAP-D (Link Access Procedure - D channel) signaling to establish 64 kbps PPP (Point-to-Point Protocol) or 128 kbps PPP-ML (Point-to-Point Protocol - Multilink) sessions between Terminal Adapter (TA) and Internet Protocol (IP) router devices.
- Provides loop current to detect continuity.
- Initiation of ANSI T1.601 2B+D loopback from DIU to any remote.
- 2047 test pattern generator and checker for each DSL (GDC 600 series NTU products)
- Performance monitoring, such as Maintenance, Alarms, Programmable Alarm Thresholds, and Diagnostics.

## Options

The NIU/DIU 7624 consists of three printed circuit cards, a basecard (not shown in Figure 1), a daughter card and a plug-in card. *Figure 1* shows the daughter card and the plug-in card where DIP switch S1 is mounted. *Table 1* describes the hard options selected by S1 that can be set Up or Down with a small screwdriver. *Table 2* describes the soft options selected by Telnet - Operation UAS 7624 Local Management GDC Pub. No. 087R710-000, or the TEAM 7624 for UNIX GDC Pub. No. 087R708-V100. You need to check these settings when you first install the card. You need not repeat the procedure unless you change the network.

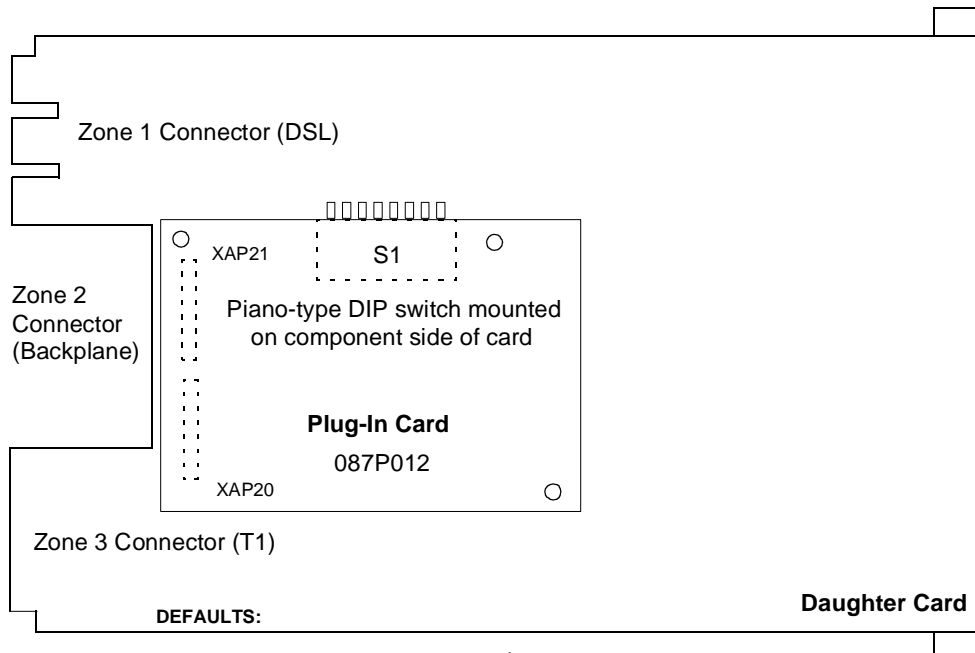

The Default option choices (*italics*) are not silkscreened on the card. Default positions are Down (Off) towards the daughter card. Refer to *Table 1* and *Table 2* for option settings.

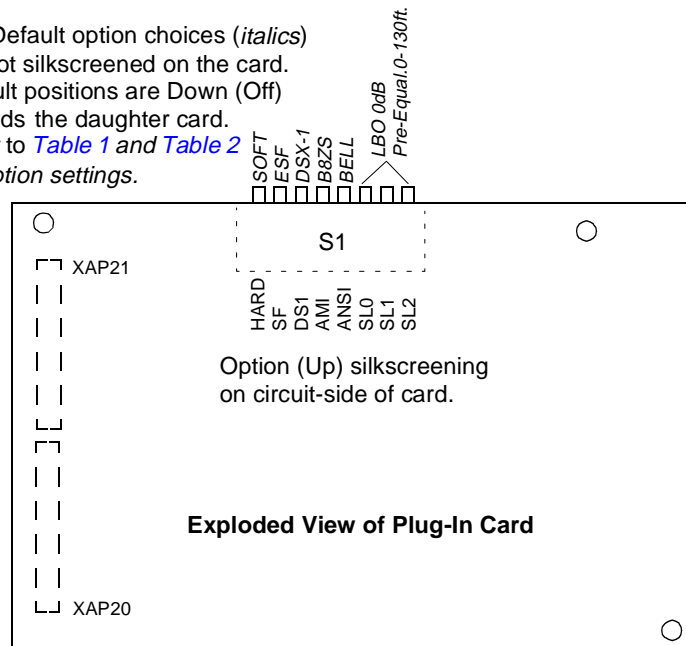

**Figure 1** NIU/DIU 7624 Option Selection

**Table 1** NIU/DIU 7624 Hard Configuration Option Settings

| Options   | Default<br>Position of S1<br>(Down = Off)   | Description  |
|---|---|--|
| <i>SOFT/HARD</i>  | <i>SOFT</i>                                 | You may select hard or soft configuration.   |
| <i>ESF/SF</i>   | <i>ESF</i>                                  | Framing Mode:<br>ESF - Extended Super Frame: consists of twenty four consecutive frames.<br>SF - Superframe: consists of twelve consecutive frames.  |
| <i>DSX-1/DS1</i>  | <i>DSX-1</i>                                | Network Interface Type:<br>DSX-1 - configures the interface to operate as a standard cross-connect DSX-1.<br>DS-1 - configures the interface to operate as a standard DS-1.  |
| <i>B8ZS/AMI</i>   | <i>B8ZS</i>                                 | One of two types of network interface Line Coding may be selected:<br>B8ZS - Bipolar with 8 Zero Substitution encoding.<br>AMI - Alternate Mark Inversion encoding.  |
| <i>BELL/ANSI<br/>(DS-1)</i>                                       | <i>BELL</i>                                 | Selects FDL mode:<br>ANSI T1-403 - bit oriented.<br>Bellcore - TR54016 - byte oriented (HDLC).   |
| <i>SL0 - SL2</i><br><br><i>LBO</i><br><br><i>Pre-Equalization</i> | <br><br><i>0 dB</i><br><br><i>0-130 ft.</i> | Allows you to select Line Buildout (LBO) for a DS-1 Network Interface Type or Pre-Equalization for a DSX Interface Type. Refer to "SL0/SL2 Option Settings" table below.<br><br>Line Build Out is the line build out value of the DS-1 interface. The selections are: 0, -7.5, -15, and -22 dB.<br><br>Pre-Equalization is the pre-equalization of the transmitter of the DSX-1 interface. The selections are: 0-130, 130-260, 260-390, 390-530, and 530-655 feet. |

**SL0/SL2 Option Settings**

|  |     |     | LBO        | Pre-Equalization |
|--|-----|-----|------------|------------------|
| SL2  | SL1 | SL0 | (DS-1)     | (DSX-1)          |
| Off  | Off | Off | 0 dB       | 0-130 ft.        |
| Off  | Off | On  | -7.5 dB    | 130-260 ft.      |
| Off  | On  | Off | -15 dB     | 260-390 ft.      |
| Off  | On  | On  | -22 dB     | 390-530 ft.      |
| On   | X   | X   | do not use | 530-655 ft.      |
| Off = Down (toward daughter card)<br>On = Up<br>X = Don't Care |     |     |            |                  |



**Table 2** NIU/DIU Soft Configuration Option Settings

| Options   | Default   | Description   |
|---|-----------|---|
| ESF/SF  | ESF       | Same as S1 switch setting in Table 1.   |
| DSX-1/DS1   | DSX-1     | Same as S1 switch setting in Table.   |
| B8ZS/AMI  | B8ZS      | Same as S1 switch setting in Table 1.   |
| Line Build-Out  | n/a       | n/a.  |
| Pre-Equalization  | 0-130     | Same as S1 switch setting in Table 1.   |
| <i>Extra options available when soft configured</i>       |           |   |
| BELL/ANSI/None  | None      | Selects either BELL, ANSI or None.  |
| Recovered/Internal Transmit Timing                        | Recovered | Allows you to select the Transmit Clock source:<br>Recovered - Slave timing from the T1 network. When Recovered is selected and there is no timing source, transmit timing defaults to Internal.<br>Internal - Internal clock source.   |
| Inhibit/  | Inhibit   | Allows you to select or inhibit the Loopback Configuration:<br>Inhibit - When you select this option, inband codes are ignored.<br>Payload - When selected, the recovered T1 is looped back toward the network.<br>Line Loop - When selected, the Telco received signal is looped back toward the network.<br>Both Payload and Line loopbacks are initiated upon recognition of inband loop-up codes or by using UAS 7624 Local Management or UAS TEAM 7624 for UNIX Manager. |
| AIS Loop-Down Inhibit/5-60 seconds in 1 second Increments | Inhibit   | You can select or inhibit the AIS Loopdown time - The time in seconds when receiving a continuous AIS before a network- initiated loopback is terminated. This time-out can be 5 to 60 seconds, or inhibited.   |
| Framing Mode  | Manual    | Allows you to select automatic or manual Framing Mode.  |
| LBO Control   | Manual    | Allows you to select automatic or manual Line Build-Out for DS-1.   |

## Installing the NIU/DIU 7624

When you are satisfied that the option settings on the plug-in card are correct, install the 7624 card in the shelf following the directions below:

1. Insert the card into its slot with the GDC logo on top, then slide it in until it makes contact with the rear panel connectors.
2. Pull down the insertion/extraction tab on the front panel and firmly push the card in until it seats in the rear connectors.

To remove a card, pull down the insertion/extraction tab to unseat the card, then pull back on the tab.

## Cabling the 7624

50-pin Telco connectors J17 and J20 provide the DSL connections to the 7624 cards installed in slots 1-6. Likewise, J18 and J21 provides the DSL connection for slots 7-12. J19 provides the connections for slots 13-16. Refer to [Table 3](#) for connector pinouts. The shelf also provides 16 DB-25 connectors in Zone 3. Refer to [Table 4](#) for connector pinouts.

### Mixing Cards in The UAS Shelf

When you mix NIU/DIU 7624s with NIU 7001s and DIU 7616s in the same UAS Shelf we recommend that you install the 7001 cards in slots 13 to 16 (shaded areas) and the 7616 and 7624 cards in slots 1 to 12. You can then cable the T1 and DSL connections as shown in [Figure 2](#). This avoids mixing T1 and DSL signals in the same 50-pin connector. The lower-numbered DB-25 connector of the pair of slots occupied by the 7624 provides the T1 signals. Use wire-wrap adapter (048P068-001) at this connector for connection to a RJ48H E-Block.

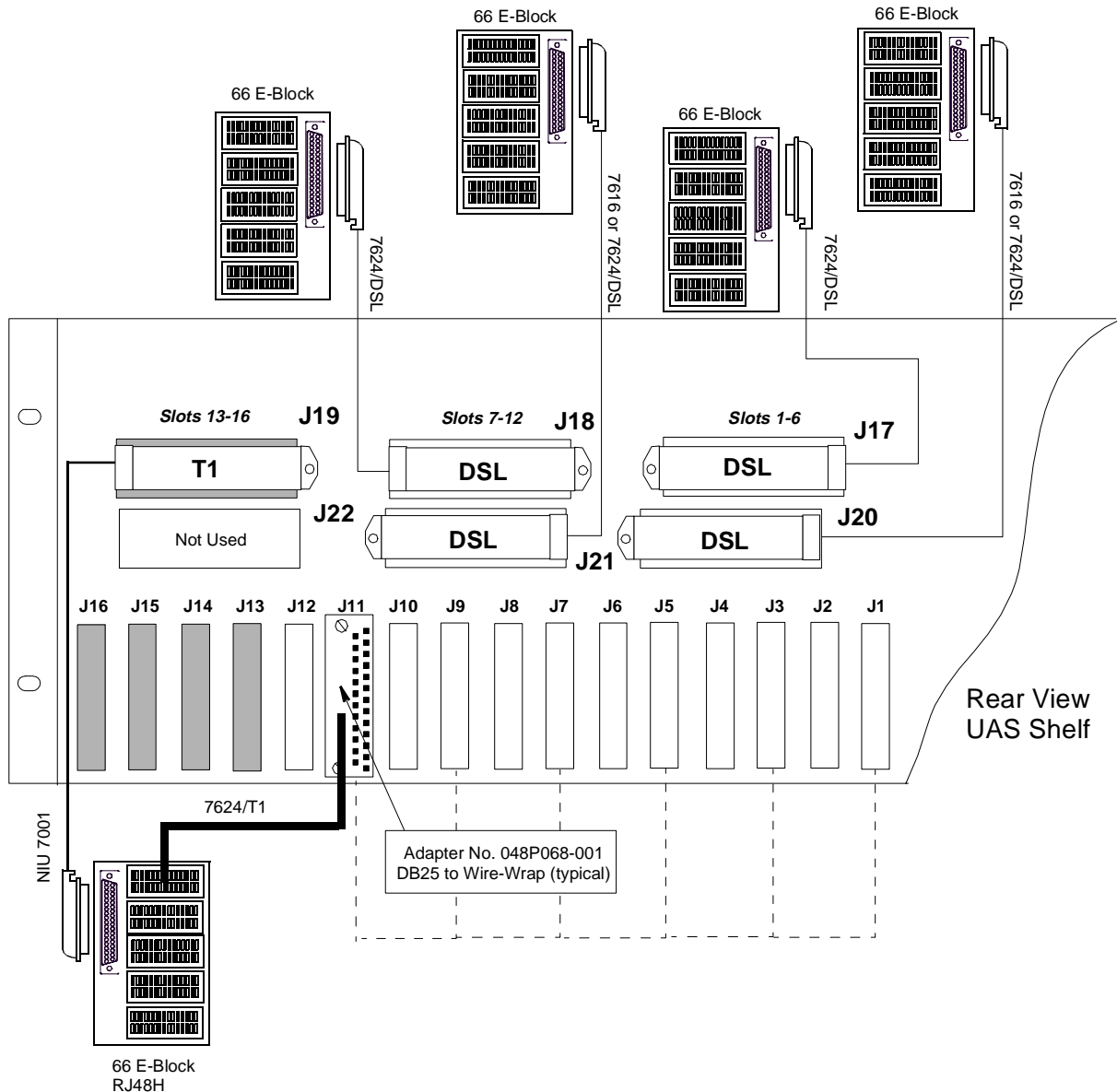

**Figure 2** A Mixed UAS Shelf

### 50-Pin Telco Mapping

Refer to [Table 3](#) for the pin mapping of the 50-pin Telco connector.

**Table 3** 50-Pin Telco Mapping (UAS Shelf Rear Panel "J" Nos.)

|   | Slot No. | "J" No. | DSL   |    |       |    | DSL   |    |       |    | DSL   |    |       |    |
|---|----------|---------|-------|----|-------|----|-------|----|-------|----|-------|----|-------|----|
|   |          |         | Tip   |    | Ring  |    | Tip   |    | Ring  |    | Tip   |    | Ring  |    |
| <b>7624</b><br>in slots<br><b>1 &amp; 2</b>   | 1        | 20      | DSL1  | 1  | DSL1  | 26 | DSL2  | 28 | DSL2  | 3  | DSL3  | 4  | DSL3  | 29 |
|   | 1        | 17      | DSL4  | 1  | DSL4  | 26 | DSL5  | 28 | DSL5  | 3  | DSL6  | 4  | DSL6  | 29 |
|   | 2        | 20      | DSL7  | 5  | DSL7  | 30 | DSL8  | 32 | DSL8  | 7  | DSL9  | 8  | DSL9  | 33 |
|   | 2        | 17      | DSL10 | 5  | DSL10 | 30 | DSL11 | 32 | DSL11 | 7  | DSL12 | 8  | DSL12 | 33 |
| <b>7624</b><br>in slots<br><b>3 &amp; 4</b>   | 3        | 20      | DSL1  | 9  | DSL1  | 34 | DSL2  | 36 | DSL2  | 11 | DSL3  | 12 | DSL3  | 37 |
|   | 3        | 17      | DSL4  | 9  | DSL4  | 34 | DSL5  | 36 | DSL5  | 11 | DSL6  | 12 | DSL6  | 37 |
|   | 4        | 20      | DSL7  | 13 | DSL7  | 38 | DSL8  | 40 | DSL8  | 15 | DSL9  | 16 | DSL9  | 41 |
|   | 4        | 17      | DSL10 | 13 | DSL10 | 38 | DSL11 | 40 | DSL11 | 15 | DSL12 | 16 | DSL12 | 41 |
| <b>7624</b><br>in slots<br><b>5 &amp; 6</b>   | 5        | 20      |       | 17 |       | 42 |       | 44 |       | 19 |       | 20 |       | 45 |
|   | 5        | 17      |       | 17 |       | 42 |       | 44 |       | 19 |       | 20 |       | 45 |
|   | 6        | 20      |       | 21 |       | 46 |       | 48 |       | 23 |       | 24 |       | 49 |
|   | 6        | 17      |       | 21 |       | 46 |       | 48 |       | 23 |       | 24 |       | 49 |
| <b>7624</b><br>in slots<br><b>7 &amp; 8</b>   | 7        | 21      |       | 1  |       | 26 |       | 28 |       | 3  |       | 4  |       | 29 |
|   | 7        | 18      |       | 1  |       | 26 |       | 28 |       | 3  |       | 4  |       | 29 |
|   | 8        | 21      |       | 5  |       | 30 |       | 32 |       | 7  |       | 8  |       | 33 |
|   | 8        | 18      |       | 5  |       | 30 |       | 32 |       | 7  |       | 8  |       | 33 |
| <b>7624</b><br>in slots<br><b>9 &amp; 10</b>  | 9        | 21      |       | 9  |       | 34 |       | 36 |       | 11 |       | 12 |       | 37 |
|   | 9        | 18      |       | 9  |       | 34 |       | 36 |       | 11 |       | 12 |       | 37 |
|   | 10       | 21      |       | 13 |       | 38 |       | 40 |       | 15 |       | 16 |       | 41 |
|   | 10       | 18      |       | 13 |       | 38 |       | 40 |       | 15 |       | 16 |       | 41 |
| <b>7624</b><br>in slots<br><b>11 &amp; 12</b> | 11       | 21      |       | 17 |       | 42 |       | 44 |       | 19 |       | 20 |       | 45 |
|   | 11       | 18      |       | 17 |       | 42 |       | 44 |       | 19 |       | 20 |       | 45 |
|   | 12       | 21      |       | 21 |       | 46 |       | 48 |       | 23 |       | 24 |       | 49 |
|   | 12       | 18      |       | 21 |       | 46 |       | 48 |       | 23 |       | 24 |       | 49 |
| <b>7624</b><br>in slots<br><b>13 &amp; 14</b> | 13       | 22      |       | 1  |       | 26 |       | 28 |       | 3  |       | 4  |       | 29 |
|   | 13       | 19      |       | 1  |       | 26 |       | 28 |       | 3  |       | 4  |       | 29 |
|   | 14       | 22      |       | 5  |       | 30 |       | 32 |       | 7  |       | 8  |       | 33 |
|   | 14       | 19      |       | 5  |       | 30 |       | 32 |       | 7  |       | 8  |       | 33 |
| <b>7624</b><br>in slots<br><b>15 &amp; 16</b> | 15       | 22      |       | 9  |       | 34 |       | 36 |       | 11 |       | 12 |       | 37 |
|   | 15       | 19      |       | 9  |       | 34 |       | 36 |       | 11 |       | 12 |       | 37 |
|   | 16       | 22      |       | 13 |       | 38 |       | 40 |       | 15 |       | 16 |       | 41 |
|   | 16       | 19      |       | 13 |       | 38 |       | 40 |       | 15 |       | 16 |       | 41 |

When mixing cards, refer to "Mixing Cards in The UAS Shelf" on page 6.

Note: This table assumes you install a 7624 starting with slots 1 & 2. If the 7624 is placed in another pair of slots, the DSL numbers will change accordingly.

## DB-25 Zone 3 Pinouts

Refer to [Table 4](#) for the pin mapping of the Zone 3 DB-25 connector.

**Table 4** Zone 3 UAS Shelf DB-25 Pinouts

| <b>Zone 3 (P2)</b>   |                    |                  |
|----------------------|--------------------|------------------|
| <b>DB-25 Pin No.</b> | <b>Description</b> | <b>Direction</b> |
| 3                    | Transmit Tip       | From 7624        |
| 16                   | Transmit Ring      | From 7624        |
| 1                    | Receive Tip        | To 7624          |
| 14                   | Receive Ring       | To 7624          |

## Front Panel Indicators

Table 5 describes the front panel indicators.

**Table 5** Front Panel Indicators

| Indicators |  |
|------------|--|
| LED        | Use  |
| ON         | Power applied<br>Green - Lights when power is applied.   |
| RSP        | Response<br>Green - Lights upon transmission of a backplane management response.   |
| LOOPS      | Loop LEDs<br>Red/Green (Bi-color) - Solid green = Good connection and in sync;<br>Flashing green = Loop in test; Red = Alarm state (no current or sync.) |
| TM         | Test Mode<br>Red - Lights when the test mode is entered by NIU.  |
| ALM        | Alarm<br>Red - Flashes during LCV, AIS, OOF, or LOS states.  |
| LCV        | Line Code Violation<br>Red - Lights upon reception of bipolar violations in the received T1 AMI signal.  |
| AIS        | Alarm Indication Signal<br>Red - Lights upon reception of a signal from the network Terminal Element (TE) that it cannot send a framed DS1 signal.       |
| LOS        | Loss Of Signal<br>Red - Lights upon absence of received T1 signal.   |
| OOF        | Out Of Frame<br>Red - Lights upon detection of severely errored seconds or wrong T1 framing pattern.   |

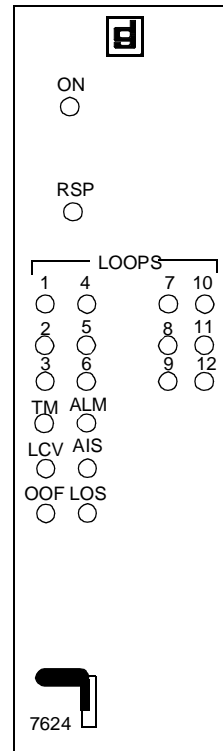

### Tests

The NIU/DIU 7624 performs the following diagnostic loopbacks: See *Figure 3* through *Figure 11*. UAS 7624 Local Management (VT-100 or Telnet) may initiate, T1 Line Loopback, T1 Payload Loopback, Digital Loop, Self Test, and Remote Digital Loop. TEAM 7624 for UNIX Manager, can control all tests.

#### T1 Line Loopback

T1 Line Loopback loops the Telco receive path to the transmit path, back towards the T1 network.

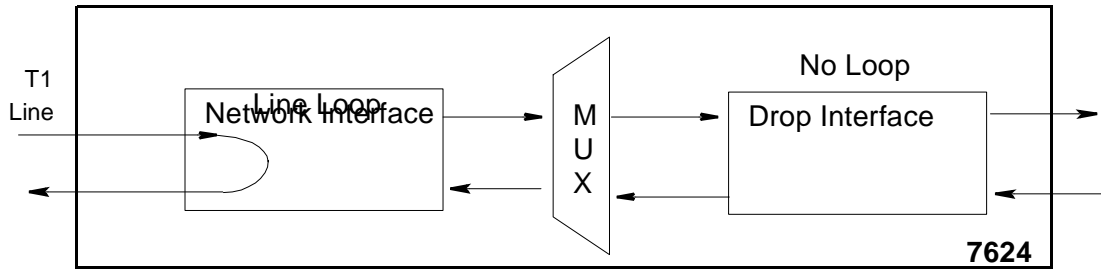

Figure 3 T1 Line Loopback

#### T1 Payload Loopback

T1 Payload Loopback loops the recovered T1 receive path to the transmit path, back towards the T1 network and corrects bipolar violations.

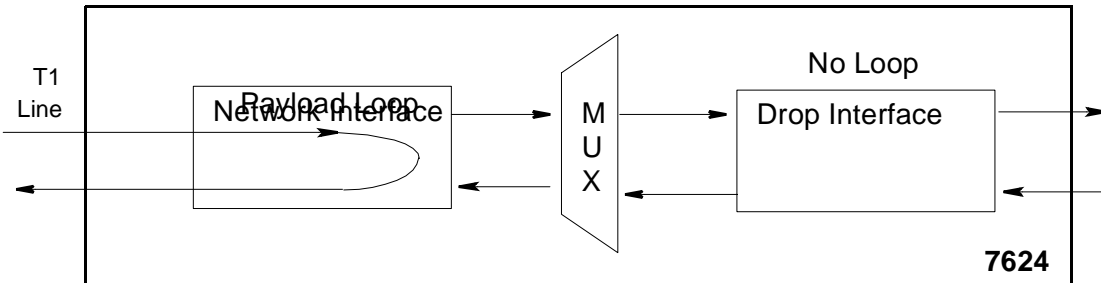

Figure 4 T1 Payload Loopback

#### Self Test

Self Test transmits a 2047 bit pattern and tests the receiver for bit errors.

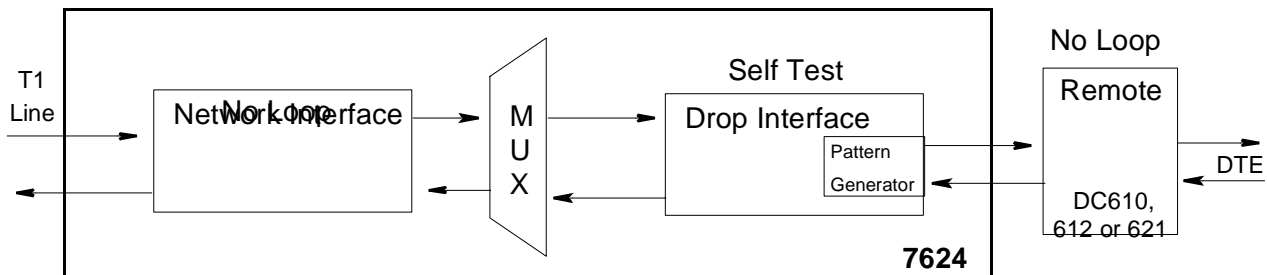

Figure 5 Self Test

### Digital Loopback

Digital Loopback loops 128 kbps (two DSOs) received path to transmits path back towards the T1 network.

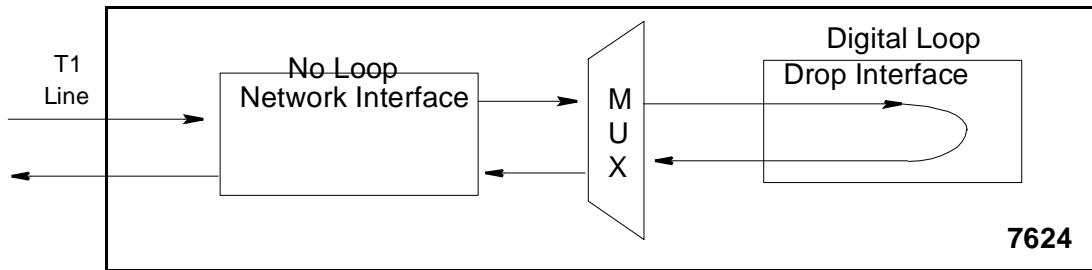

Figure 6 Digital Loopback

### Remote Digital Loopback

Remote Digital Loopback commands a remote unit to go into loopback.

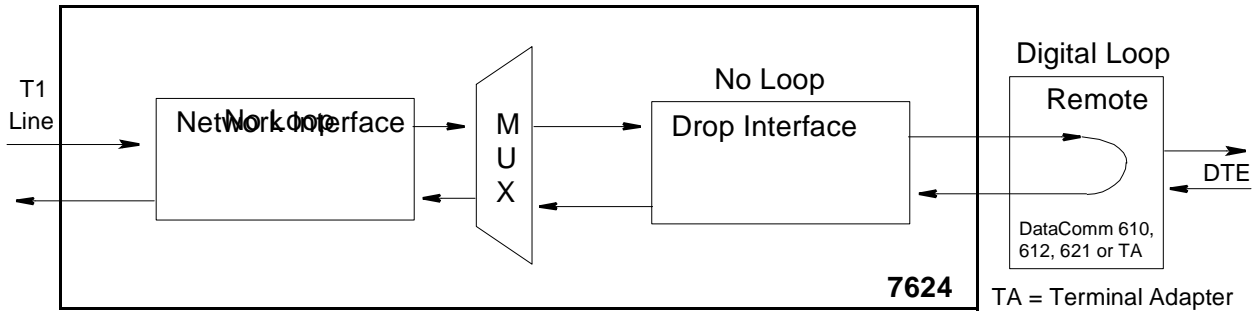

Figure 7 Remote Digital Loopback

### Remote Digital Loopback with Self Test

Remote Digital Loopback with Self Test commands a remote device to go into loopback, and the 7624 transmits a 2047-bit pattern and tests the receiver for bit errors.

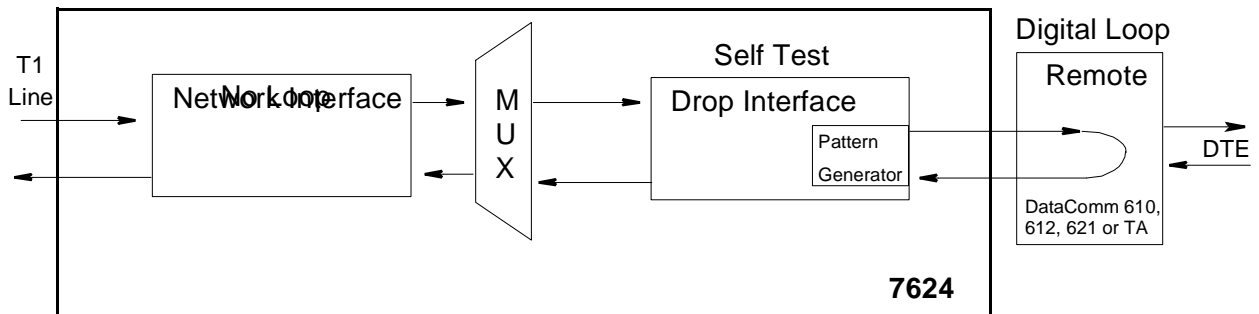

Figure 8 Remote Digital Loopback with Self Test

### Remote Bilateral Loopback

Remote Bilateral Loopback is performed at a remote unit.

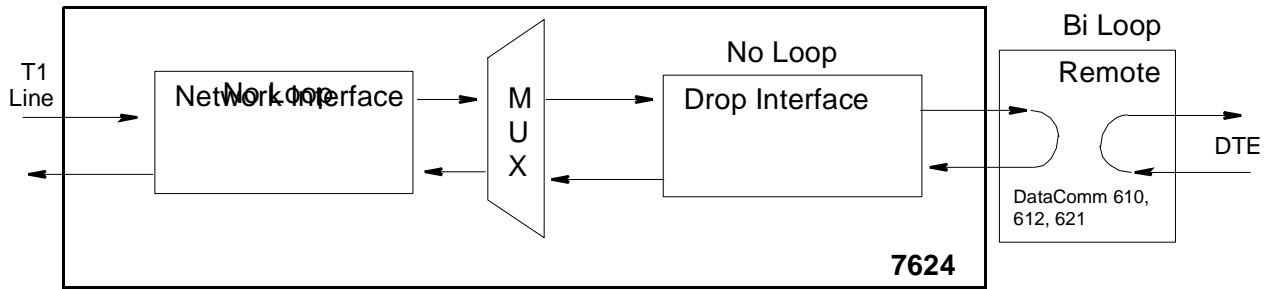

Figure 9 Remote Bilateral Loopback

### Remote Bilateral Loopback with Self Test

Remote Bilateral Loopback with Self Test is performed at a remote unit, and the 7624 master is generating the 2047 self-test pattern.

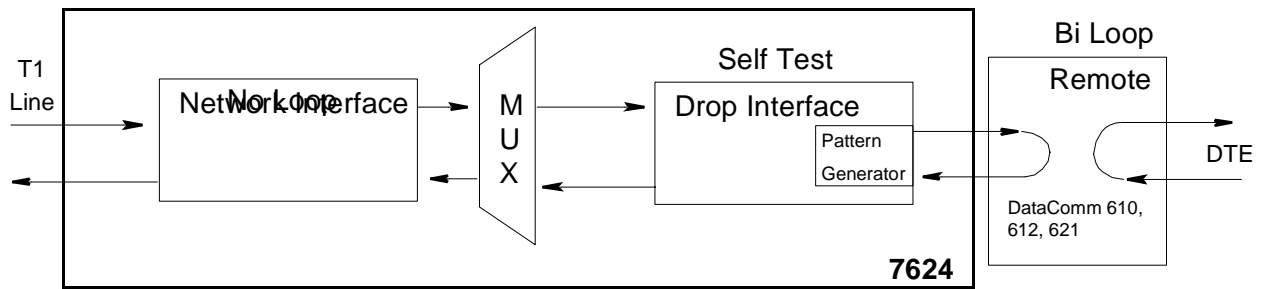

Figure 10 Remote Bilateral Loopback with Self Test

### Master to Remote Self Test

Master to Remote Self Test puts the 7624 and the remote into a self-test (2047 test pattern only).

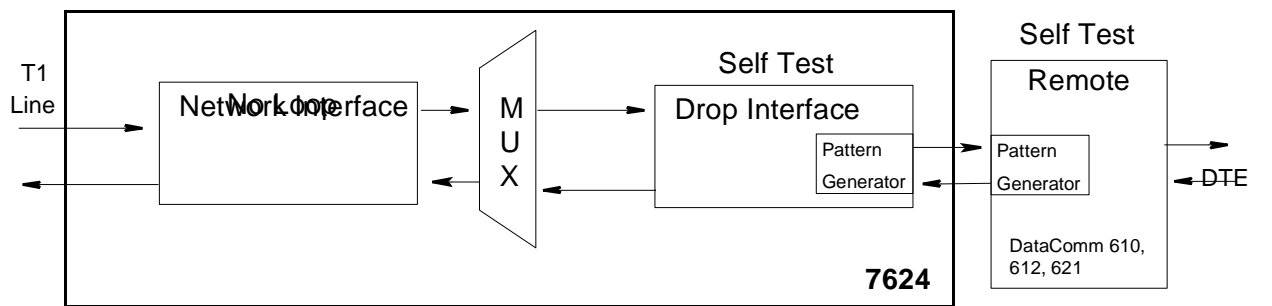
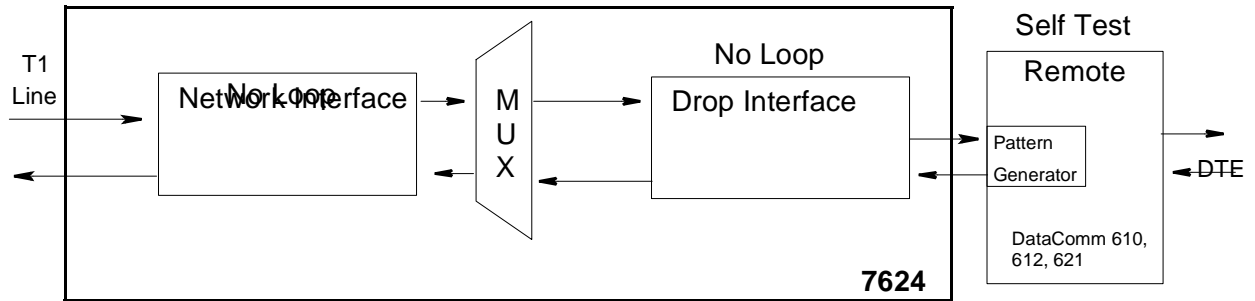

Figure 11 Master to Remote Self Test



### Remote to Remote Self Test

Remote to Remote Self Test puts the remote unit into self-test (master is transparent). (2047 or 511 test pattern).



**Figure 12** Remote to Remote Self Test

## Parts List and Specifications

The parts list and specifications for the NIU/DIU 7624 are found in [Table 6](#).

**Table 6** Parts List and Specifications

| <b>Parts List</b>           |   |
|-----------------------------|---|
| 087M010-001                 | NIU/DIU 7624 module (base card, daughter card and plug-in card)                                       |
| 048P068-001                 | DB-25 to Wire-Wrap Adapter  |
| 830-002S-xxx                | Amphenol 50-pin male- to-male cable (xxx= 5, 10, 25 and 50 ft. lengths)                               |
| <b>Specifications</b>       |   |
| Dimensions                  |   |
| Height                      | 7.0 in. (178 mm)  |
| Width                       | 1.75 in. (44.5 mm)  |
| Depth                       | 9.5 in. (241 mm)  |
| Weight                      | 1.9 lbs. (0.85 kg)  |
| Power                       | + 5 Vdc at 2A (max.)<br>+12 Vdc at 50 mA (max.)<br>-12 Vdc at 50 mA (max.)                            |
| Load Number                 | 2.0 (for 2 slots)   |
| Network Management Protocol | SNMP  |
| Ambient Temperature         |   |
| operating                   | 0 to 50° C  |
| non-operating               | -40 to 85° C  |
| Humidity (operating)        | 5% to 95% (non condensation)  |
| Altitude                    |   |
| operating                   | 0 to 10,000 feet  |
| non-operating               | 0 to 40,000 feet  |
| <b>NIU Interface</b>        |   |
| Diagnostics                 | Line Loopback, Payload Loopback, Digital Loopback.  |
| Communication line          | T1 digital carrier  |
| Line Impedance              | 100 ohm   |
| Frequency                   | 1.544 Mbps ±50 bps  |
| Line Build-Out              | 0, 7.5, 15, or 22.5 dB at 772 kHz   |
| Pre Equalization            | 0-130, 130-260, 260-390, 390-530, 530-655 feet.   |
| <b>DIU Interface</b>        |   |
| Sealing Current             | 4.5 mA nominal  |
| Operating Mode              | Full duplex with adaptive echo cancellation.  |
| Data Rate                   | 160 kbps total: 128 kbps user data, 16 kbps internal control, 16 kbps for timing and synchronization. |
| Data Format                 | Synchronous, serial binary.   |
| Line Coding                 | 2B1Q, compatible with ANSI T1.601.  |
| Line Requirements           | 2-wire, non-loaded metallic circuit.  |
| Operating Range             | 18 kft. of 26 ga.wire   |
| Performance                 | 10 <sup>-7</sup> BER on 15 ANSI T10601 test lamps.  |

## Index

---

### D

DB-25 Zone 3 Pinout 14

### F

Features 1

Front Panel Indicators 2

### I

Installation of Plug-In Card 4

Installing the NIU/DIU 7624 5

### M

Manual iv

### O

Options 3

### P

Parts List and Specifications 8

### T

Tests 10





