

UFLEX 12 MANUFACTURING THE WORLD'S FINEST MARINE PRODUCTS

UFLEX 12

**MANUFACTURING
THE WORLD'S
FINEST MARINE
PRODUCTS**

UFLEX

NEW 12



Power A Mark II™

page 8 - 15



MASTERDRIVE Power assisted steering system

page 54 - 58

NEW 12



V21B

page 81



B400
B401-ETC

page 96



"Vero Volante Italiano" wheels

page 87 - 94



Trim Tabs

page 115-118



ULTRAFLEX GROUP

77 years
1935-2012

2



UFLEX USA Inc

Manufacturing the world's finest marine products.



ULTRAFLEX S.p.a

Steering and control systems for pleasure boats.

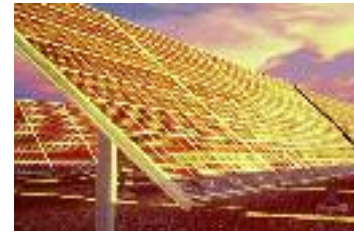

UFLEX S.r.l

Worldwide distribution of marine accessories



ULTRAFLEX - Energy Division

Systems and accessories for alternative energy applications



ULTRAFLEX CONTROL SYSTEMS S.r.l

Window and skylight remote controls. Innovative LED sign technology.



INDUSTRIA di LEVI S.r.l

Mechanical remote controls in the industrial field



MARESI LTD

Trim tabs and magnetic compasses

QUALITY MANAGEMENT SYSTEM

The Ultraflex Quality System is certified CISQ-EQ Net by the Italian Shipping Registry (RINA), in conformity with the UNI EN ISO 9001 rule, certification N420/96. The quality system involves all the company resources and processes starting from the design, in order to:

- assure product quality to the customer.
- set up the actions to maintain and improve the quality standards constantly.
- pursue a continuous process improvement to meet the market needs.
- maintain and verify conformity with ABYC requirements.





ULTRAFLEX S.P.A. certifications



www.uflexusa.com

- Technical Service ph. 941.351.2628
- Sales ph. 941.351.2628
- Administration ph. 941.351.2628

CORPORATE INFORMATION

Established in 1989 Uflex USA is a leader in steering and control systems for the marine industry. With full manufacturing capabilities in Sarasota, Florida, Uflex USA can support all sectors of the marine industry regardless of the volume and/or product requirements. And, as an affiliate of the Ultraflex Group, Uflex USA has tremendous resources to draw upon for new product development in hydraulics, electronics and many other technologies.

Innovative product design and unparalleled dedication to quality customer service and products continue to be the cornerstone of Uflex USA's growth. Today our products can be found as originally installed equipment on many of the most widely known and respected boat brands in the world. Aftermarket parts can be sourced from trained and experienced distributor network throughout North and South America.

Our dedication to providing the highest quality products and service is only matched by our commitment to developing new products employing the latest materials and technology to enhance our customer's boating experience. From steering wheels to sophisticated electronic controls, Uflex USA has everything you need to make sure that your boat looks and performs it's best for many, many years.

UFLEX USA Inc.
6442 PARKLAND DRIVE
SARASOTA, FLORIDA 34243 - USA
PH. (941) 351-2628 - FAX (941) 360-9171
www.uflexusa.com
email: sales@uflexusa.com



Ultraflex Group



**UFLEX USA®
LIMITED WARRANTY**

page 6



**Power A Mark II™
ELECTRONIC
CONTROL SYSTEM**

page 7 to 15



**SELECTING
A STEERING SYSTEM**

page 16 to 18



**MECHANICAL STEERING
SYSTEMS AND ACCESSORIES**

page 19 to 28



**PACKAGED MECHANICAL
STEERING SYSTEMS**

page 29 to 30



**HYDRAULIC STEERING
SYSTEM - HELM PUMPS**

page 31 to 38



**STANDARD
OUTBOARD STEERING**

page 39 to 45



**PACKAGED STANDARD
OUTBOARD STEERING SYSTEMS**

page 46



**SILVERSTEER™
HIGH PERFORMANCE OUTBOARD
STEERING SYSTEMS**

page 47 to 53



**MASTERDRIVE - POWER
ASSISTED STEERING SYSTEM**

page 54 to 58



**TIE BARS FOR
OUTBOARD ENGINES**

page 59 to 61

Ultraflex S.p.A. declines any liability for possible mistakes in this catalogue due to printing errors. Ultraflex S.p.A. reserves the right to make those modifications that are considered to be suitable for its products. Publishing rights, trade marks, part numbers and photographs of the Ultraflex products present on this catalogue are Ultraflex property and all rights are reserved.





**STERNDRIVE -
INBOARD STEERING**

page 62 to 67



**BULKHEAD HOSE KITS
ACCESSORIES AND FITTINGS**

page 68 to 69



**HYDRAULIC
CROSS REFERENCE GUIDE**

page 70 to 71



**BubbleBuster™
AUTOMATIC FILLING AND
PURGING SYSTEM**

page 72



STEERING WHEELS

page 73 to 94



ENGINE CONTROLS

page 95 to 110



ENGINE CONTROLS CABLES

page 111 to 114

ULTRAFLEX electronic control components are EMC certificated and CE marked in conformity with CEI EN60945 and UNI-EN ISO 11547 standards

ULTRAFLEX mechanical steering systems components are all marked CE in compliance with the EEC Directive 94/25 and the rules EN29775 - EN28848.

ULTRAFLEX hydraulic steering systems components are all marked CE in compliance with the EEC Directive 94/25 and the rule ISO 10592.

The CE Examination on the ULTRAFLEX steering systems has been carried out by an Institute certified by the European Commission.

We kindly remind you that on the boats marked CE it is compulsory to install steering systems with components marked CE (see art. 4 and 5 of Directive 94/25/CE).

The descriptions and guidelines shown in this catalog should be used as general reference only. For any further information please contact our Technical Service.

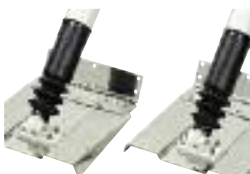

UIFLEX® TRIM TABS

page 115 - 118



**UCS® -ELECTROMECHANICAL
HATCH LIFTERS**

page 119 to 122



**UIFLEX®
MAGNETIC COMPASSES**

page 123 to 130



SPARE PARTS

page 131 to 133

UFLEX USA, INC., LIMITED WARRANTY

- Two Year Limited Warranty.** Uflex USA, Inc. warrants that all products manufactured by Uflex USA, Inc or Ultraflex S.p.A. and sold by Uflex USA to the retail purchaser ("Purchaser") that for two (2) years after the date of manufacture to be free from defects due to material or workmanship, subject to the exclusions below. Improper installation VOIDS this warranty. Installation should only be attempted by a trained and qualified technician.
- Exclusions.** This limited warranty does not cover and does not extend to any of the following:
(a) Failure caused by normal wear and tear, climatic conditions, misuse, neglect, lack of proper maintenance, accident, fire or other casualty damage, racing, overloading, negligence, modification, beaching or grounding of vessel, collision, impact, towing, acts of war or hostilities; **(b)** components not manufactured by Uflex USA, Inc., or its affiliates; **(c)** cost of removal or reinstallation of any component (including components manufactured by Uflex USA, Inc.), or disassembly and reassembly of the unit containing the component; **(d)** components not manufactured by Uflex USA, Inc. or Ultraflex S.p.A., whether or not warranted by the other manufacturer. **(e)** any product which has not been properly installed.
- Limitations.** **THE REPAIR OR REPLACEMENT OF DEFECTIVE PARTS SHALL BE PURCHASER'S SOLE AND EXCLUSIVE REMEDY AND UFLEX USA, INC.'S SOLE AND EXCLUSIVE LIABILITY UNDER THIS WARRANTY. LABOR FOR REPLACEMENT IS NOT INCLUDED.** Uflex USA, Inc.'s obligation under this warranty is limited to the repair or replacement (at Uflex USA, Inc.'s sole election) of any covered item found to be defective, when delivered by Purchaser pursuant to written authorization and instructions from Uflex USA, Inc., shipping prepaid to Uflex USA, Inc.'s, plant or other designated repair facility. Repaired or replaced items are warranted as provided herein for the unexpired portion of the applicable warranty period.
THIS WARRANTY, AND THE RIGHTS AND REMEDIES UNDER IT, IS EXCLUSIVE AND IS GIVEN IN PLACE OF ALL OTHER WARRANTIES, WHETHER EXPRESS OR IMPLIED, INCLUDING ANY IMPLIED WARRANTY OF MERCHANTABILITY OR FITNESS FOR PARTICULAR PURPOSE, WHETHER ARISING BY LAW, CUSTOM, CONDUCT OR USAGE OF TRADE. PURCHASER'S REMEDIES SHALL BE LIMITED AS STATED HEREIN AND UFLEX USA, INC. SHALL NOT BE LIABLE FOR ANY INCIDENTAL, CONSEQUENTIAL OR INDIRECT DAMAGES OR LOSSES RESULTING FROM DEFECTS. THE RETAIL SELLER IS NOT A CO-WARRANTOR AND IS NOT AUTHORIZED BY UFLEX USA, INC. TO AMEND OR MODIFY THIS LIMITED WARRANTY IN ANY MANNER.
- Transferability of Warranty.** This limited warranty may not be transferred to subsequent purchasers.
- Miscellaneous.** Uflex USA, Inc. is an affiliate of Ultraflex S.p.A. Uflex, USA, Inc., reserves the right to make changes in the design and construction of its products at any time, without notice and without any obligation to incorporate such changes into products of prior manufacture. This limited warranty applies to new components sold by Uflex USA, Inc.. This limited warranty contains the entire agreement between Uflex USA, Inc. and Purchaser and supersedes all prior agreements, discussions, negotiations, commitments and representations, whether oral or written, between them regarding Uflex USA, Inc.'s warranty. If any provision of this limited warranty, or the application of it, is determined to be invalid of unenforceable for any reason, the remainder of this limited warranty and the application of it shall not be affected.
- Power A Mark II™.** The "Power A Mark II™ - User and Installation Manual" describes activities, operations, technical specifications which must be followed during the installation and/or usage of the product, in order to keep a valid warranty. Descriptions and drawings in that manual are suitable to allow installation and use of the product to skilled persons. In case of doubt and/or for any information, please contact our Technical Service.

All communications and notices from Purchaser regarding this limited warranty should be sent to:

UFLEX USA, INC.
6442 Parkland Drive
Sarasota, Florida 34243
(941) 351-2628.

RETURNS POLICY

Any product that is presumed defective should be reported to Uflex USA within 48 hours of receipt or discovery in the field. Upon notification Uflex USA will attempt to troubleshoot the problem with our customer over the phone. If we are unable to resolve the problem Uflex will issue a Return Goods Authorization number and we require that the product in question be returned to Uflex with all of its parts in its original packaging. The product should be returned freight prepaid to:

Uflex USA
RGA Department – RGA #
6442 Parkland Drive
Sarasota, Florida 34243

Upon receipt Uflex will examine the product to determine the cause of the defect. If the product is determined to have a defect in workmanship or material, it will be repaired or replaced at our discretion.

Our warranty does not cover labor, towing or other expenses. Further, it does not cover products that have been improperly installed, damaged in installation, misapplied, or misused.

Our products are not intended for use in racing applications.

The descriptions and guidelines shown in this catalog should be used as general reference only. For any further information please contact our Technical Service.



Power & Control

ELECTRONIC CONTROL SYSTEM

ELECTRONIC CONTROL SYSTEM

The easy to install PowerA Mark II™ control system provides fingertip operation of throttle and shift levers.

Using reliable and precise digital data transmission, this single or dual function control system is specifically designed to work on mechanically controlled as well as electronic and electro-hydraulic gas and diesel inboards, sterndrives and outboards.

The PowerA Mark II™ comes with many features including Dock Assist, which offers the operator the opportunity to reduce the sensitivity of the throttle function for easier dockside handling.

Other standard features include RPM Synchronization, which reduces engine vibration and improves fuel economy, a High Idle feature to increase RPM where higher idle is necessary for cold engine operations, a programmable Trolling Valve Control and neutral Warm Up.

The stylish and ergonomically designed control makes the PowerA Mark II™ suitable for many types of applications ranging from sport boats, yachts and commercial applications.

Available with and without trim, the control has audible and visual interfaces which alert the operator to the current status of the control system.

With the ability to control up to 2 engines from up to 4 different stations, the PowerA Mark II™ is a modular and flexible system with simple to install components.

The unique Control Unit Display of the PowerA Mark II™ provides simple touch pad programming with descriptive information regarding the set up, tuning and diagnostics of the system.

The Power A Mark II is a system that can replace mechanical controls either on fully mechanical engines, or on fully electronic engines, or on engines with the combination of both characteristics.

PRIVATE PROTOCOL CAN BUS FOR DATA TRANSMISSION

SUITABLE FOR MECHANICAL SHIFT AND THROTTLE AS WELL AS ELECTRONIC THROTTLE AND SHIFT

CONNECTION OF MULTIPLE STATIONS UP TO 4 CONTROLS

MODULAR SYSTEM

DIRECT COMMUNICATION WITH ELECTRONIC ENGINES (SAE J 1939 or NMEA 2000)

PLUG'N PLAY CONNECTIVITY

AUTOMATIC ENGINES SYNCHRONIZATION

DOCK ASSIST

FULLY PROGRAMMABLE SHIFT DELAYS

PERSONALIZED LABEL UPON REQUEST

CONTROL STATIONS:

Control without trim:

Single engine	- 42009 G
Twin engines	- 42011 T

Control with trim:

Single engine	- 42010 R
Twin engines	- 42012 V

IP protection: IP66



The "Power A Mark II™ - Installation and User Manual" describes activities, operations, technical specifications which must be followed during the installation and/or usage of the product, in order to keep a valid warranty and obtain the better performance. Description and drawings in that manual are suitable to allow an easy installation and safe use of the product by skilled personnel. In case of doubt and/or for any information, please contact our Technical Service.

PLEASE REFER TO LIMITED WARRANTY CONDITIONS REPORTED IN THIS CATALOGUE.

TECHNICAL FEATURES:

- Single Lever/Dual Function and Dual Lever/Dual Function for shift, throttle and trolling
- Up to 4 control stations
- Power supply: min 9 max 32V
- Working temperature: -25°C to +75°C
- Control station functions:
 - Station Select
 - Engines Warm up
 - High idle
 - Docking
 - Engine synchronization
 - Trolling valve
- Electronic throttle outputs:
 - Voltage (double output 0 - 5V and 0 - 2,5V)
 - PWM (0-100%, frequency from 200Hz to 1kHz)
 - Current (4 - 10mA)
- Digital Throttle Output:
 - SAE J 1939
 - NMEA 2000
- Trolling valve output
 - Voltage (0 - 5V)
 - PWM (0-100%, frequency from 100Hz to 1 kHz)
 - Current (4 - 20mA)
- Electric shift control:
 - 2 or 3 ON/OFF or proportional solenoids
 - Shift delays fully settable

SAFETY DEVICES:

- Start in-gear PROTECTION(start inhibition with shifted gear)
- Audible and visual diagnostic failure alarm (READABLE MESSAGES ON THE CONTROL UNIT DISPLAY)
- Proportional shift delays
- Programmable working parameters
- Meets CEI EN 60945 standards

EMC CERTIFICATION AND CE MARK

Conforms with:

- CEI EN60945
- UNI-EN ISO 11547

COMPATIBILITY WITH ALL MECHANICAL THROTTLE ENGINES

COMPATIBILITY WITH ALL ELECTRONIC THROTTLE ENGINES

- Cummins, Detroit Diesel, Scania, Iveco, FPT, Lombardini, VM Motori, FNM, Yanmar, CMD-Volkswagen, Hyundai ecc.

The Power A Mark II™ electronic system actuators cannot be installed in those rooms where ignition-proof devices are required.



SYSTEM CONTROL UNITS

10



Control Unit

Control Unit - 42017 F
Control Unit: user interface for the configuration, settings and diagnostic of all the modules in a system.
IP protection: IP65
Dim.: 215 x 120 mm (8.5" x 4.7")



**V-Throttle
I-Throttle**

V-Throttle - 42018 H - for 0-5V interfaces (voltage)
I-Throttle - 42019 K - for 4-20 mA interfaces (current)
They supply the throttle electronic signal. Required for use with direct connection to electronic throttle on the engine.
IP protection: IP65
Dim.: 205 x 110 mm (8" x 4.3")



SAEJ-Throttle

SAEJ-Throttle - 42022 Y
It supplies the digital signal to CAN SAEJ 1939 or NMEA 2000 interfaces
IP protection: IP65
Dim.: 205 x 110 mm (8" x 4.3")



Shift Unit

Shift Unit - 42023 A
It controls up to 2 shifts with solenoids. Required for use with direct connection to the electrical shift unit on the transmission.
IP protection: IP65
Dim.: 210 x 120 mm (8.3" x 4.7")



E-Troll

E-Troll - 42024 C - It controls up to 2 electronic Trolling Valves
The **Shif Unit** (42023A) controls up to 2 PWM Trolling Valves.
They control up to 2 Trolling Valves with solenoids.
IP protection: IP65
Dim.: E-Troll 205 x 110 mm (8" x 4.3")
Shift Unit 210 x 120 mm (8.3" x 4.7")



Power Unit

Power Unit - 42026 G
Grants the power supply up to 4 modules with the input combination of up to 2 batteries, 12 and 24V. Required for all PowerA Mark II installations.
IP protection: IP65
Dim.: 205 x 110 mm (8" x 4.3")



M-Actuator

M-Actuator - 42027 J
The electromechanical actuators can control any mechanical interface (throttle shift or trolling) through MACHZero and C8 mechanical cables.
IP protection: IP66
Length: 320 mm (12.6")

CHART A - E-Throttle Unit

MODEL	P. No.	DESCRIPTION	FEATURES	No. OF ENGINES	NOTE
V-Throttle	42018H	Throttle with analog voltage interface	Redundant voltage input, IVS, PWM output.	1 - 2	FPT, Volkswagen, Yanmar, Mercruiser, Lombardini engine.
I-Throttle	42019K	Throttle with current analog interface (current loop)	Current outputs.	1 - 2	4 - 20 mA throttle engines
SAEJ - Throttle	Custom	Throttle with SAEJ 1939 digital interface	CAN DeviceNet SAEJ 1939 outputs	1 - 2	SAEJ 1939 engines
NMEA - Throttle	Custom	Throttle with NMEA 2000 digital interface	CAN DeviceNet NMEA 2000 outputs	1 - 2	NMEA 2000 engines

CHART B - Throttle cables

MODEL	APPLICATION	LENGTH (m - ft)	P. No.	NOTE
Universal V-Throttle cable	Not redundant 5V cable/1 engine	2 - 6,6 4 -13,1	42029N 42030X	None
FPT V-Throttle cable	FPT engines 0 – 5 V cable (J-INV connector)	2 - 6,6 4 -13,1	42031Z 42032B	FPT, all engines with J-INV connector
FPT V-Throttle cable	FPT engines 0 – 5 V cable (J-D connector)	2 - 6,6 4 -13,1	42316S 42317U	FPT, all engines with J-D connector
VW V-Throttle cable (4-5-6 cylinder)	VW engines 0 – 5 V cable	2 - 6,6 4 -13,1	42033D 42034F	VW, 4, 5 and 6 cylinder
Mercruiser 4.2 Black V-Throttle cable	Mercruiser engines 0 – 5 V cable	2 - 6,6 4 -13,1	42035H 42036K	Mercruiser 4.2 black engines
Mercruiser QSD V-Throttle cable	Mercruiser engines 0 – 5 V cable	2 - 6,6 4 -13,1	42037M 42038P	Mercruiser QSD engines
Lombardini V-Throttle cable	Lombardini engines 0 – 5 V cable	2 - 6,6 4 -13,1	42039S 42040A	180 and 240 HP Lombardini engines.
Yanmar V-Throttle cable	Yanmar engines 0 – 5 V cable	2 - 6,6 4 -13,1	42041C 42042E	Yanmar BY engines.
Universal I/PWM-Throttle cable	PWM throttle cable with no connector	2 - 6,6 4 -13,1	42043G 42044J	Compatible with CAT electronic engines C30/C32
Universal SAEJ1939-Throttle cable	SAEJ1939 cable with no connector	2 - 6,6 4 -13,1	42045L 42046N	None
NMEA2000 Throttle cable	NMEA2000 cable	1 - 3,3 3 - 9,8 7 - 22,9	42047R 42048T 42049V	DeviceNet cable Drop type for NMEA2000 connection
Hyundai V-Throttle cable	Hyundai engines 0 – 5 V cable	2 - 6,6 4 -13,1	42288P 42289S	Hyundai engines
VM V-Throttle cable	VM engines 0 – 5 V cable	2 - 6,6 4 -13,1	42314M 42315P	VM engines



11

CHART C - Main system cables

DESCRIPTION	APPLICATION	LENGTH (m - ft)	P. No.	NOTE
Main power supply cable	Main power supply of the system	1 - 3,3 3 - 9,8 7 - 22,9 10 - 32,8	42052H 42053K 42054M 42055P	One each battery
Power cable extension	Power extension cable for modules connection	1 - 3,3 3 - 9,8 7 - 22,9 10 - 32,8	42056S 42057U 42058W 42059Y	One each mechanical actuator or shift unit
Shift cable	Solenoid connection cable	1 - 3,3 3 - 9,8 7 - 22,9 10 - 32,8	42060G 42061J 42062L 42063N	One each solenoid shift
Shift cable with electric Troll	Shift and trolling solenoid connection cable	1 - 3,3 3 - 9,8 7 - 22,9 10 - 32,8	42064R 42065T 42066V 42067X	One each shift and trolling with solenoids
3 solenoid Shift cable (neutral solenoid)	3 solenoid connection cable	1 - 3,3 3 - 9,8 7 - 22,9 10 - 32,8	42072P 42073S 42074U 42075W	One each 3 solenoid shift
CAN cable	Network connection cable	1 - 3,3 3 - 9,8 7 - 22,9 10 - 32,8 15 - 49,2 20 - 65,6	73639T 73680P 73681S 71021K 71031N 71032R	CAN cable

Note:

Should the engine inverter need the neutral solenoid, the proper shift cable must be used.
Custom cabling can be done, upon request

CHART D - Troll cables

DESCRIPTION	APPLICATION	LENGTH (m - ft)	P. NO.	CONNECTORS
Universal V-Troll cable	0-5 V cable with no redundancy	2 - 6,6 4 - 13,1	42068Z 42069B	None
Universal I-Troll cable	4-20 mA output cable, no connectors included	2 - 6,6 4 - 13,1	42070K 42071M	None

Spare parts

MODEL	DESCRIPTION	PART No.	Q.ty
Cable connection kit	Kit to connect the mechanical cable to the actuator	41898 N	1 for each actuator
Conduit clamp kit	Conduit clamp kit for mechanical cable	41897 L	1 for each actuator

12

CHART E - Components for Trolling Valve Systems

ENGINE	NO. OF ENGINES	COMPONENTS	P. No.	Q.TY
Mechanical trolling valve	Single Engine	Mechanical actuator (Troll) CAN cable Power cable extension	42027J Chart C Chart C	1 1 1
	Twin Engines	Mechanical actuator Power Unit CAN cable Power supply cable (general) Power cable extension	42027J 42026G Chart C Chart C Chart C	2 0 (*) 2 0 (*) 2
(*) When there are no more free sockets in the existing power unit, add one Power Unit with one or two power supply cables according to battery number. Refer to the diagram on installation manual.				
Electric troll (proportional solenoid)	Single Engine	Shift Unit CAN cable Power cable extension Cavo Shift con Troll	42023A Chart C Chart C Chart C	1(**) 1(**) 1(**) 1
	Twin Engines	Shift Unit CAN cable Power cable extension Power Unit Power supply cable (general) Shift cable with Troll	42023A Chart C Chart C 42026G Chart C Chart C	1(**) 1(**) 1(**) 0 (*) 0 (*) 2
(*) When there are no more free sockets in the existing power unit, add one Power Unit with one or two power supply cables according to battery number. Refer to the diagram on installation manual.				
(**) When a shift unit is already present in the system, it can control the electric troll by using the proper cable. When a shift box is not present, add one to the system with the shift and CAN cables.				
Electronic Troll (0-5V, 4-20mA)	Single Engine	E-Troll Unit CAN cable Troll cable	42024C Chart C Chart D	1 1 1
	Twin Engines	E-Troll Unit CAN cable Troll cable	42024C Chart C Chart D	1 1 2



14

ENGINE	NO. OF ENGINES	COMPONENTS	P. No.	Q.TY
Electronic throttle	Single Engine	Single control with trim (or no trim)	42010R (42009G)	1
		Control Unit	42017F	1
		E-Throttle unit	Chart A	1
		E-Shift unit	42023A	1
		Throttle cable	Chart B	1
		Shift cable	Chart C	1
		Power supply cable (general)	Chart C	1
		CAN cable	Chart C	3
		Network terminators	42028L	1
		Power Unit (optional for second battery)	42026G	1
Power cable extension (optional for second battery)	Chart C	1		
Power supply cable (optional for second battery)	Chart C	1		
Electric shift	Two Engines	Dual control with trim (or no trim)	42012V (42011T)	1
		Control Unit	42017F	1
		E-Throttle unit	Chart A	1
		E-Shift unit	42023A	1
		Throttle cable	Chart B	2
		Shift cable	Chart C	2
		Power supply cable (general)	Chart C	1
		CAN cable	Chart C	3
		Network terminators	42028L	1
		Power Unit (optional for second battery)	42026G	1
Power cable extension (optional for second battery)	Chart C	1		
Power supply cable (optional for second battery)	Chart C	1		
Electronic throttle	Single Engine	Single control with trim (or no trim)	42010R (42009G)	1
		Control Unit	42017F	1
		E-Throttle unit	Chart A	1
		Mechanical actuator	42027J	1
		Throttle cable	Chart B	1
		CAN cable	Chart C	3
		Power supply cable (general)	Chart C	1
		Network terminators	42028L	1
		Power Unit (optional for second battery)	42026G	1
		Power cable extension (optional for second battery)	Chart C	1
Power supply cable (optional for second battery)	Chart C	1		
Mechanical shift	Two Engines	Dual control with trim (or no trim)	42012V (42011T)	1
		Control Unit	42017F	1
		E-Throttle unit	Chart A	1
		Mechanical actuator	42027J	2
		Throttle cable	Chart B	2
		CAN cable	Chart C	4
		Power supply cable (general)	Chart C	1
		Network terminators	42028L	1
		Power Unit	42026G	1
		Power extension cable	Chart C	2
Power supply cable (optional for second battery)	Chart C	1		
For each additional station add:				
Single Engine:	Single lever control station with trim (or no trim)	42010R (42009G)	1	
	CAN cable	Chart C	1	
Two Engines:	Dual lever control station with trim (or no trim)	42012V (42011T)	1	
	CAN cable	Chart C	1	

ENGINE	NO. OF ENGINES	COMPONENTS	P. No.	Q.TY	
Mechanical throttle	Single Engine	Single control with trim (or no trim)	42010R (42009G)	1	
		Control Unit	42017F	1	
		E-Throttle unit	42023A	1	
		Mechanical actuator	42027J	1	
		Throttle cable	Chart C	1	
		CAN cable	Chart C	3	
		Power supply cable (general)	Chart C	1	
		Network terminators	42028L	1	
		Power Unit (optional for second battery)	42026G	1	
		Power cable extension (optional for second battery)	Chart C	2	
		Power supply cable (optional for second battery)	Chart C	1	
Electronic shift	Two Engines	Dual control with trim (or no trim)	42012V (42011T)	1	
		Control Unit	42017F	1	
		E-Throttle unit	42023A	1	
		Mechanical actuator	42027J	2	
		Throttle cable	Chart C	2	
		CAN cable	Chart C	4	
		Power supply cable (general)	Chart C	1	
		Network terminators	42028L	1	
		Power Unit	42026G	1	
		Power extension cable	Chart C	3	
		Power supply cable (optional for second battery)	Chart C	1	
Mechanical throttle Mechanical shift	Single Engine	Single control with trim (or no trim)	42010R (42009G)	1	
		Control Unit	42017F	1	
		Mechanical actuator	42027J	2	
		CAN cable	Chart C	3	
		Power supply cable (general)	Chart C	1	
			Network terminators	42028L	1
			Power Unit	42026G	1
			Power extension cable	Chart C	2
			Power supply cable (optional for second battery)	Chart C	1
	Two Engines	Dual control with trim (or no trim)	42012V (42011T)	1	
Control Unit		42017F	1		
Mechanical actuator		42027J	4		
CAN cable		Chart C	5		
Power supply cable (general)		Chart C	1		
		Network terminators	42028L	1	
		Power Unit	42026G	1	
		Power extension cable	Chart C	4	
		Power supply cable (optional for second battery)	Chart C	1	
For each additional station add:					
Single Engine:	Single lever control station with trim (or no trim)	42010R (42009G)	1		
	CAN cable	Chart C	1		
Two Engines:	Dual lever control station with trim (or no trim)	42012V (42011T)	1		
	CAN cable	Chart C	1		





SELECTING A STEERING SYSTEM

Choosing the appropriate system for your application can sometimes be confusing because of the variety of steering systems available. There are 4 basic steering types: Mechanical Rotary, Mechanical Rack, Hydraulic and Power Steering that cover most of the styles of recreational powerboats. The Mechanical Rotary, Mechanical Rack and Pinion are available in standard or Zerotorque Feedback versions.

Steering Torque →



Selecting among these options is dependent upon the speed and handling characteristics of your particular boat. If your boat is an outboard or if it has a sterndrive without power steering, you need to consider steering systems that reduce the rudder torque feedback that you feel while driving your boat.

Feedback is the constant effort you have to put on the steering wheel just to go straight, and it is why it takes more effort to steer one direction than the other. The amount of feedback depends on the boat, the propeller and the steering system in the boat. Generally speaking, the faster you are going the more amount of effort you have to put on the steering wheel to keep the boat going straight.

PLANETARY GEAR DESIGN:

Uflex offers a rotary system featuring a "Planetary Gear Design" with 3 satellite gears which distributes steering feedback more evenly and effectively throughout the helm. The result is a reduction in the amount of effort needed to steer the boat straight or into the direction of the steering torque.



The Uflex Planetary Gear Design also spreads the wear of the steering direction changes over a wider wear area which reduces overall wear and the correspondent lost motion.

The competitively priced complete system from Uflex is called the Rotech. This package includes a helm, bezel and cable. It is a direct replacement for competing rotary systems requiring no new holes in the dash.

ROTECH

The Planetary Gear Design of the Rotech contrasts conventional systems which have only one contact point between two drive gears. The single contact point of conventional systems receives all the torque from the engine, which can eventually lead to uneven gear wear and correspondent lost motion in the steering.



Single Contact Point

ACCURA

For outboard boats, sterndrives without power assist or other applications with moderate torque loads it is recommended to upgrade to system with a clutch or gears which automatically lock out the steering torque while the system is not actively being turned.

Uflex offers the Accura system with the same Planetary Gear Design but in a ZeroTorque configuration, which does not require a constant effort on the steering wheel to keep the boat going straight or in the intended direction.

A special spring clutch holds the steering system on its intended course until the next change in the direction is initiated by the driver.

RACKTECH

Rack and Pinion steering systems are generally found on boats where space between the drivers knees and the steering helm is limited. Racks were particularly common in the early 70's on ski boats where the freeboard of the boats were very small.

Today's boats generally have enough space to fit a rotary helm, making the rack systems less popular as OEM installed option.

Rack and Pinion systems have the similar design issues as conventional rotary helms. Accordingly, all the steering loads are transmitted to one contact point and there is uneven wear in the system.

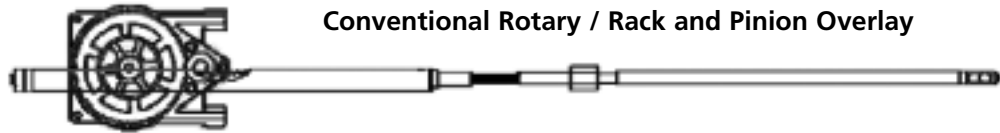

ACCUTECH

For boats that do have space constraints, Uflex offers the Racktech steering package that consists of a helm, bezel and steering cable. The ZeroTorque version of the Uflex rack and pinion is the Accutech, which features a spring clutch to allow for smooth transition in and out of the ZeroTorque mode.

Both systems come with the M86 Rack Cable which has an armor wrapped stranded wire core for high efficiency and smooth steering.

If you have a boat that has the space, it is recommended to take advantage of the Planetary Gear Designed rotary helms to reduce feedback and to improve longevity of the helm.

HYDRAULICS

Hydraulics are more and more popular on mid to high horsepower outboard applications. The increased application of hydraulics has a lot to do with the increase in horsepower over the years, and the added torque that is inherent with 4 stroke outboards compared to 2 strokes. The high output torque of the 4 strokes has changed the propellers resulting in higher torque loads on the steering systems. Hydraulic systems are very efficient in dealing with all torque conditions and often provide for fingertip steering effort.

Outboards systems are generally broken down into two systems; one for application below 150 hp and a different system for 150 and above.

HYCO

Uflex offers the Hyco package which has a clever mounting system that allows you to install a front mount outboard cylinder without having to remove the engine. With the split tilt tube design of the Uflex Hyco, you can simply cut the old mechanical steering cable, insert the two tilt tube pieces independently and pin them to complete the hydraulic cylinder installation.

The cylinder is suspended in front of the engine and oil directed from the hydraulic helm moves the engine correspondent to the direction of the steering wheel.



PROTECH

Larger horsepower applications require a more robust steering cylinder. The Uflex Protech cylinder is designed for single, dual and triple engine applications up to 750 hp. Featuring heavy duty seals, 304 electropolished link assemblies, and a carbon steel piston, it is built for the most demanding applications.



SELECTING A STEERING SYSTEM

Uflex offers a simple application guide to assist in selecting the appropriate model cylinder according to the make and model of your engine at www.uflexusa.com. The Uflex helms are compatible with competing helms, hoses, cylinders and oil, so you can easily install a Uflex component regardless of what item you need to replace.



18

SILVERSTEER

For especially high torque applications you may want to consider using a 1500 psi helm, which has relief valves set 500 Psi higher than the standard hydraulic helms which are rated to 1000 Psi. Bass, flats and other high horsepower boats with jackplates and shallow V deadrise experience extreme torque where the helm needs to have higher relief settings.

Uflex offers the Silversteer helm and cylinder for these applications. With the same benefits as the Protech cylinder, the Silversteer cylinder also features a keyed bullhorn design that maximizes the rigidity of the cylinder when dealing with peak torque loads.

Large inboard boats with displacement hulls can generate high torque loads. Uflex offers a wide variety of hydraulic helms and cylinders that can be paired together to provide optimal steering for your application.

EFFICIENCY COMPARISON TESTS

Test configuration:
3 bends at 90°; 1000N load

NOTE: indicated figures have been obtained after 500 cycles of running from samples bought from after-market sources

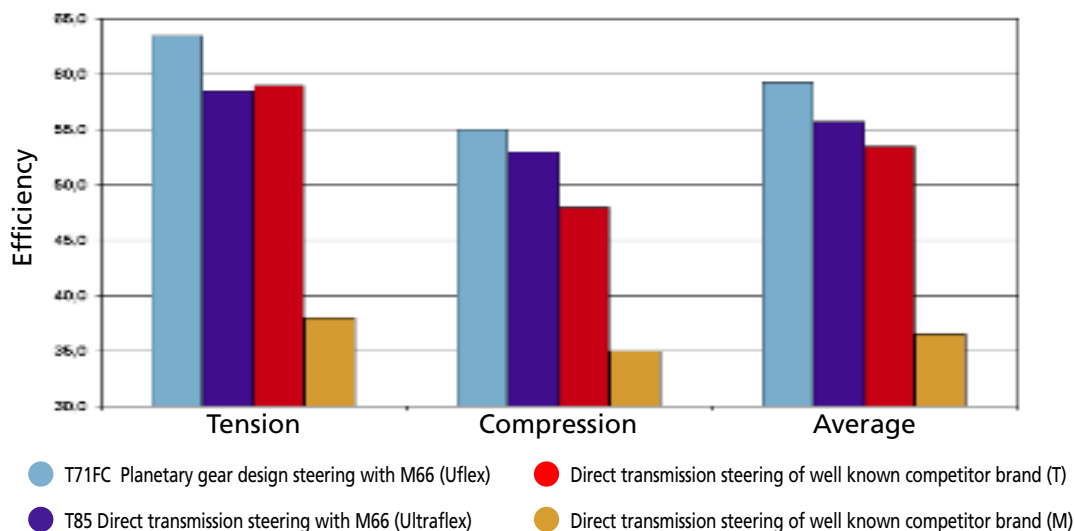

USE AND MAINTENANCE

The steering cable must be installed avoiding excessive and/or tight bends. This will provide the driver with easy handling at all speeds, helping to reduce system inefficiency, and excess play in the system.

Marine corrosion may cause the materials to deteriorate affecting maneuvering efficiency and in the worst case, system failure. By following the engine manufacturer specifications, the steering cable end fittings and the engine cable support must be cleaned and greased periodically; these simple operations minimize wear and corrosion in the system.



The steering cable must be regularly inspected. If steering becomes hard, inconsistent, cuts on the conduit surface are noticed, or any other component found damaged, the cable must be replaced immediately.

When storing your boat for an extended period of time we recommend removing the steering cable end fitting from its engine side support and cleaning it adequately.





SELECTION OF STEERING SYSTEM AND CABLE LENGTH MEASUREMENT

APPLICATION	BOAT LENGTH	STEERING SYSTEM	
OUTBOARD 	up to 30' (9m)	T71FC - T81FC T73NRFC - T83NRFC G86 - G88NR G96 - G98NR	Twin cable systems are recommended for boats that exceed 50 mph. Always follow engine manufacturer's instructions.
		twin cable rotary steering systems	
INBOARD 	up to 35' (10.5m)	T71FC - T81FC T73NRFC - T83NRFC G86 - G88NR G96 - G98NR	
		twin cable rotary steering systems	
STERNDRIVE POWER ASSISTED 		T71FC - T81FC G86 - G96	
		twin cable rotary steering systems	

NOTE: sterndrive engines not equipped with power steering can create very high steering loads. Our hydraulic steering systems are recommended for these type of boats. For any further information please contact our Technical Service Department.

- Speed, hull, horsepower, engine type, displacement and size are major factors in boat performance and handling characteristics. The above selection guide should be used as a general reference only.
- One of the major factors in selecting a steering system is proper cable length. Due to specific routing in each boat, these approximate lengths will vary. Final selection should be made with the assistance of a qualified technician.
- Ultraflex mechanical steering systems should not be used on boats equipped with engines that exceed the maximum horsepower rating of the boat.

HOW TO MEASURE FOR NEW STEERING CABLE INSTALLATION

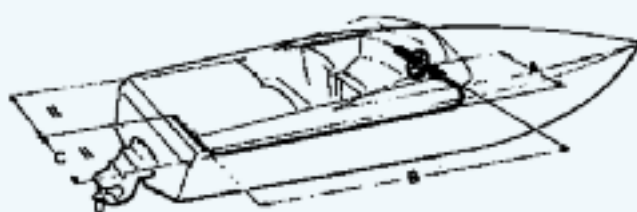

Add the lengths of A + B + C together and subtract 4" (10 cm) for each 90° bend. Add 12" (30,5 cm) for the engine tilt tube. To order in foot length, round up to the nearest whole foot.



Fig. 1

TILT TUBE MOUNTING - Fig. 1

Example:
 $A (2.5') + B (10.5') + C (3') = 16'$
 $16' - 8''$ (two 90° bends) = $15'4''$
 $15'4'' + 12''$ (tilt tube) = $16'4''$
 Round up to 17'



Fig. 2

TRANSOM SUPPORT OR SPLASHWELL MOUNTING - Fig. 2-3

Example:
 $A (2.5') + B (10.5') + C (3') = 16'$
 $16' - 8''$ (two 90° bends) = $15'4''$
 Round up to 16'

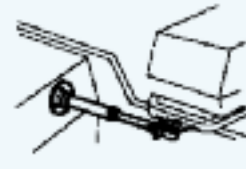
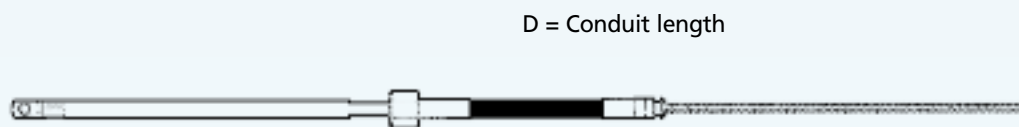

Fig. 3

HOW TO MEASURE FOR REPLACEMENT STEERING CABLES







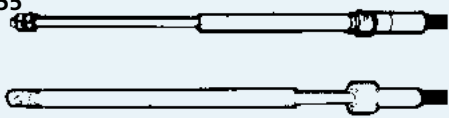
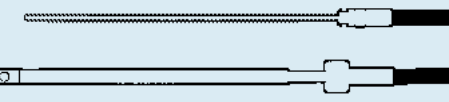

D = Conduit length

ORDER LENGTH: "D" dimension + 22" and round up to the next whole foot

Example: $D = 120'' + 22'' = 142''$ (11'8"). Round up to 12 ft

REPLACEMENT STEERING CABLES

ULTRAFLEX REPLACEMENT CABLE	STEERING HELM	ADAPTOR REQUIRED
M55 	Ultraflex P15	none
	Teleflex® ATB RACK - SSC122	M55 AD
M66 	Ultraflex T71FC - T72FC - T73NR FC - T81FC - T82FC - T83NR FC - Teleflex® Safe - TQC®/NFB® - Morse® D290	none
	Ultraflex year 2001 and prior: T71 - T72 - T73NR T74NR - T81 - T82 T83NR - T84NR	K66 - 38432Q 
M47 - DISCONTINUED USE M66 + K66 	Ultraflex year 2001 and prior: T71 - T72 - T73NR T74NR - T81 - T82 T83NR - T84NR	none
	Ultraflex T71FC - T72FC - T73NR FC - T81FC - T82FC - T83NR FC Morse® D290	K46-35679L 
	Teleflex® Safe - T® - Big-T®	none
M86 	Ultraflex G86 - G88NR G96 - G98NR Morse® Command 200 Teleflex® "THE RACK" SSC-124	none
NOTE: Will not work with dual cable helms		
M68 + M67D 	Dual station steering systems: Ultraflex T71FC	none

Part numbers for ordering:

- M55 XLL LL = Length of cable
- M66 XLL LL = Length of cable
- M86 XLL LL = Length of cable
- M68 XLL LL = Length of cable
- M67D XLL LL = Length of cable

T71FC AND T72FC ROTARY STEERING SYSTEMS



FEATURING PLANETARY GEAR DESIGN

A COMPLETE STEERING SYSTEM CONSISTS OF:

- Steering helm:
 - T71FC - 38867 H - single cable steering helm
 - T72FC - 38868 K - dual cable steering helm
 - Mounting bezel:
 - X34 - 36654 B - black, 90° mounting
 - X34W - 40654 C - white, 90° mounting
 - X35 - 36655 C - black, 20° mounting
 - Steering cable: **M66**
- NOTE: two M66 are needed with the T72FC system
- Optional steering wheel (see index)
 - Engine connection kits (see index)

FEATURES AND TECHNICAL SPECIFICATIONS

- Fast connect, simple installation
 - All stainless steel cable output ends
 - Corrosion resistant materials
 - Particularly suitable where clearance is limited
 - Optional 90° or 20° installation
 - Standard 3/4" tapered shaft
 - Lock-to-lock steering wheel turns: approx. 3,8
 - Stroke: 9" (228 mm)
 - Maximum allowable steering wheel diameter: 16" (406 mm)
 - Minimum steering cable bend radius: 7.9" (200 mm)
 - Minimal feedback
 - Compact for mounting
 - T71FC and T72FC steering systems are not to be used on boats equipped with engines that exceed the maximum horsepower rating of the boat
 - For boats faster than 50 mph the twin cable steering system T72FC is recommended
 - T71FC steering system is also available in package with ROTECH, which includes the X35 bezel and M66 cable.
- Exceeds EN 28848 safety standards
 - Exceeds ABYC P17 safety standards



T71FC



T72FC



X34W

X34



X35

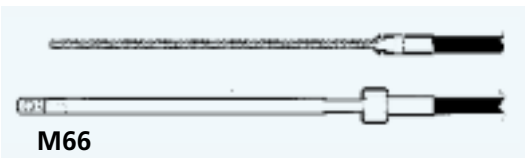

M66

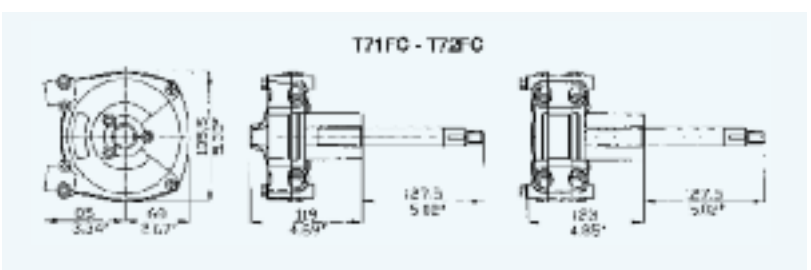

T73NRFC® NON-REVERSIBLE STEERING SYSTEM



**FEATURING
PLANETARY GEAR
DESIGN**

A COMPLETE STEERING SYSTEM CONSISTS OF:

- Steering helm:
T73NRFC - 38869 M
single cable steering helm
- Mounting bezel:
X34 - 36654 B - black, 90° mounting
X34W - 40654 C - white, 90° mounting
X35 - 36655 C - black, 20° mounting
- Steering cable: **M66**
- Optional steering wheel (see index)
- Engine connection kits (see index)

FEATURES AND TECHNICAL SPECIFICATIONS

- Easy and safe steering : a **patented non-reversible mechanism** eliminates the continuous load on the operator caused by the propeller torque
- Fast connect, simple installation
- Compact rotary helm unit: the central location of the steering shaft makes these systems the most compact in their class
- Most suitable where clearance is limited
- Ideal for outboards and surfacing propellers
- Optional 90° or 20° installation
- Standard 3/4" tapered shaft
- All stainless steel cable output ends
- Made exclusively in corrosion resistant materials
- Lock-to-lock steering wheel turns: approx 3,8
- Stroke: 9" (228 mm)
- Maximum allowable steering wheel diameter: 16" (406 mm)
- Minimum steering cable bend radius: 7.9" (200 mm)
- T73NRFC steering system is not to be used on boats equipped with engines that exceed the maximum horsepower rating of the boat
- Available in package including the X34 bezel and M66 cable with ACCURA
- Exceeds EN 28848 safety standards
- Exceeds ABYC P17 safety standards

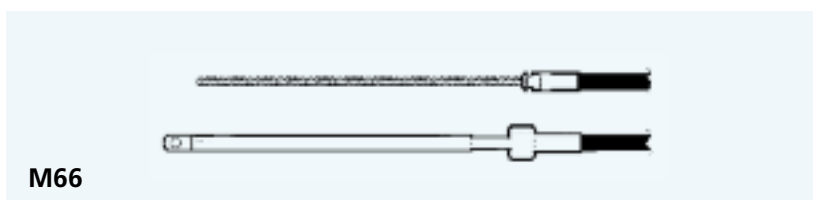
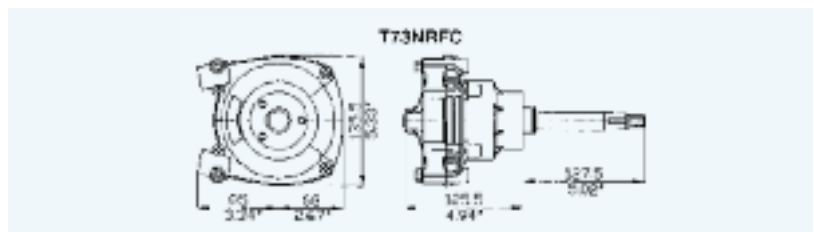

T81FC - T82FC - T83NRFC® TILT STEERING SYSTEMS

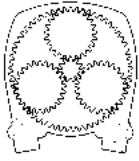

**FEATURING
PLANETARY GEAR
DESIGN**



24

A COMPLETE STEERING SYSTEM CONSISTS OF:

- Steering helm:
 - T81FC** - 38957 J
single cable steering helm
 - T82FC** - 38958 L
dual cable steering helm
 - T83NRFC** - 38959 N
non-reversible single cable steering helm
- Tilt mechanism:
 - X52** - 39250 U
NOTE: X52 tilt mechanism fits Uflex tilt mount rotary and rack and pinion steering helms as well as Ultraflex tilt mount hydraulic pumps except  steering systems
- Steering cable: **M66**
NOTE: two M66 are needed with the T82FC system
- Optional steering wheel (see index)
- Engine connection kits (see index)

FEATURES AND TECHNICAL SPECIFICATIONS

- Tilt range of 48° and five locking positions
- Fast connect, simple installation
- Tilt device eliminates underdash movement
- Standard 3/4" tapered shaft - stainless steel
- All stainless steel cable output ends
- Corrosion resistant materials
- Lock-to-lock steering wheel turns: approx. 3,8
- Stroke: 9" (228 mm)
- Maximum allowable steering wheel diameter: 16" (406 mm)
- Minimum steering cable bend radius: 7.9" (200 mm)
- T81FC, T82FC and T83NRFC steering systems are not to be used on boats equipped with engines that exceed the maximum horsepower rating of the boat
- For boats faster than 50 mph the twin cable steering system T82FC is recommended
- Exceeds EN 28848 safety standards
- Exceeds ABYC P17 safety standards



T81FC with X52



X52

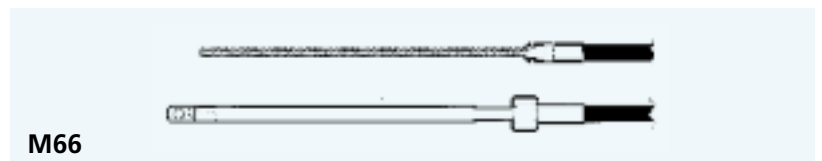

M66

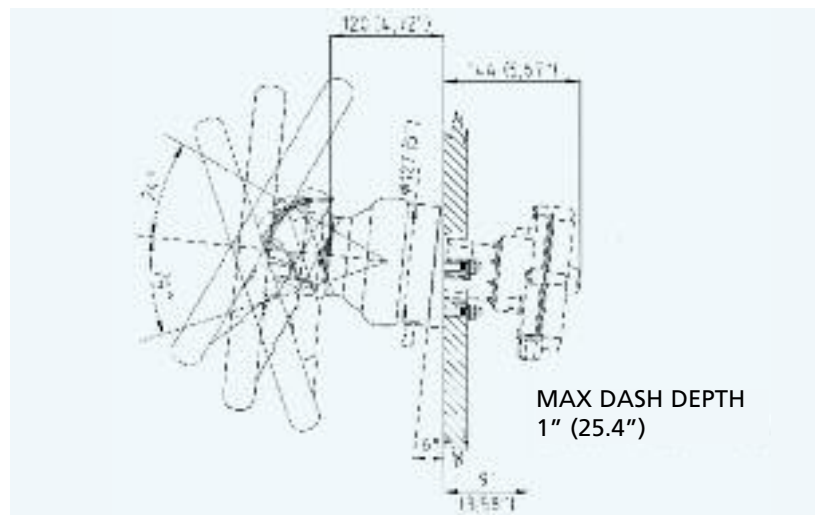

MAX DASH DEPTH
1" (25.4")

G86 AND G88NR® RACK AND PINION STEERING SYSTEMS

A COMPLETE STEERING SYSTEM CONSISTS OF:

- Preassembled helm with steering cable:
M86
- Helm assembly:
G86 - 39418 G standard
G88NR® - 39419 J - non reversible
- Mounting bezel:
X34 - 36654 B - black, 90° mounting
X34W - 40654 C - white, 90° mounting
X35 - 36655 C - black, 20° mounting
- Optional steering wheel (see index)
- Engine connection kits (see index)

FEATURES AND TECHNICAL SPECIFICATIONS

- Easy and safe steering: patented non reversible G88NR helm eliminates the continuous load on the operator caused by the propeller torque
- All stainless steel cable output ends
- Made exclusively in corrosion resistant materials
- Optional 90° or 20° installation
- Standard 3/4" tapered shaft
- Lock-to-lock steering wheel turns: 3,5
- Stroke: 8.2" (210 mm)
- Maximum allowable steering wheel diameter: 16.5" (420 mm)
- Minimum steering cable bend radius: 7,9" (200 mm)
- G86 and G88 NR steering systems are not to be used on boats equipped with engines that exceed the maximum horsepower rating of the boat
- Available in package includes X34 bezel and M66 cable with RACKTECH and ACCUTECH
- Exceeds EN 28848 safety standards
- Exceeds ABYC P17 safety standards

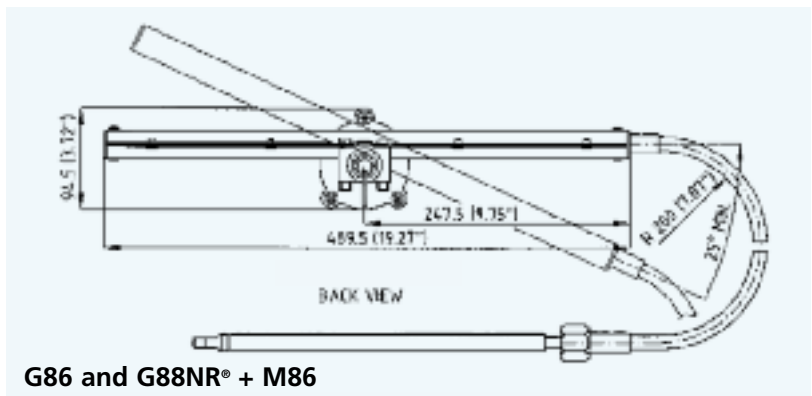
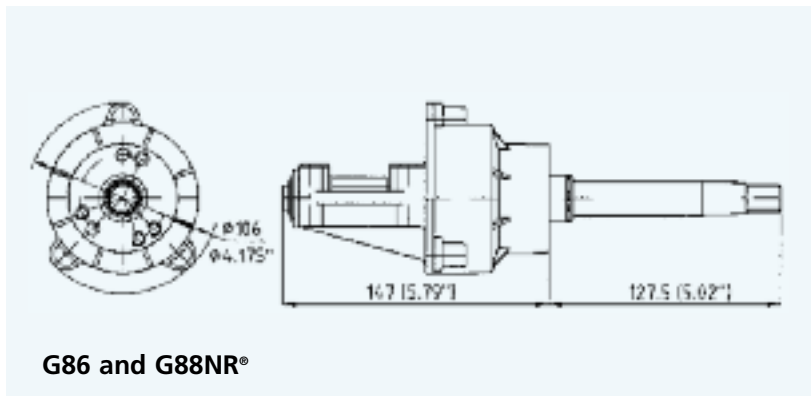
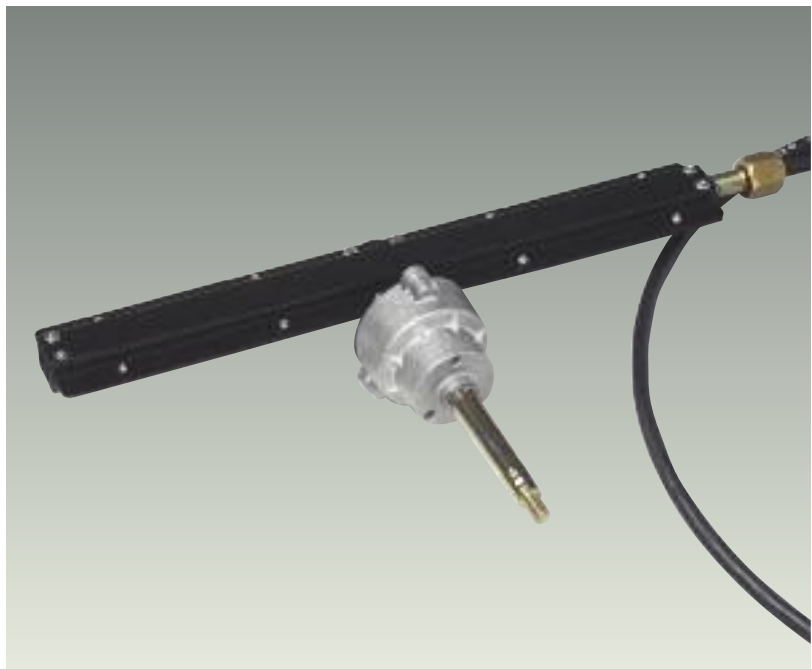



G96 AND G98NR® RACK AND PINION TILT STEERING SYSTEMS

A COMPLETE STEERING SYSTEM CONSISTS OF:

- Preassembled helm with steering cable: **M86**
- Helm assembly:
G96 - 39650 L standard
G98NR® - 39649 C non reversible
- Tilt mechanism:
X52 - 39250 U
NOTE: X52 tilt mechanism fits Ultraflex tilt mount rotary and rack and pinion steering helms as well as Ultraflex tilt mount hydraulic pumps except ~~steering systems~~ steering systems
- Optional steering wheel (see index)
- Engine connection kits (see index)



FEATURES AND TECHNICAL SPECIFICATIONS

- Easy and safe steering: the patented non reversible G98NR helm eliminates the continuous load on the operator caused by the propeller torque
- Fast, simple installation
- Tilt range of 48° and five locking positions
- Tilt device eliminates underdash movement
- Standard 3/4" tapered shaft - stainless steel
- All stainless steel cable output ends
- Made exclusively in corrosion resistant materials
- Lock-to-lock steering wheel turns: 3,5
- Stroke: 8.2" (210 mm)
- Maximum allowable steering wheel diameter: 16.5" (420 mm)
- Minimum steering cable bend radius: 7.9" (200 mm)
- G96 and G98NR® steering systems are not to be used on boats equipped with engines that exceed the maximum horsepower rating of the boat
- Exceeds EN 28848 safety standards
- Exceeds ABYC P17 safety standards



G96 and G98NR®



X52

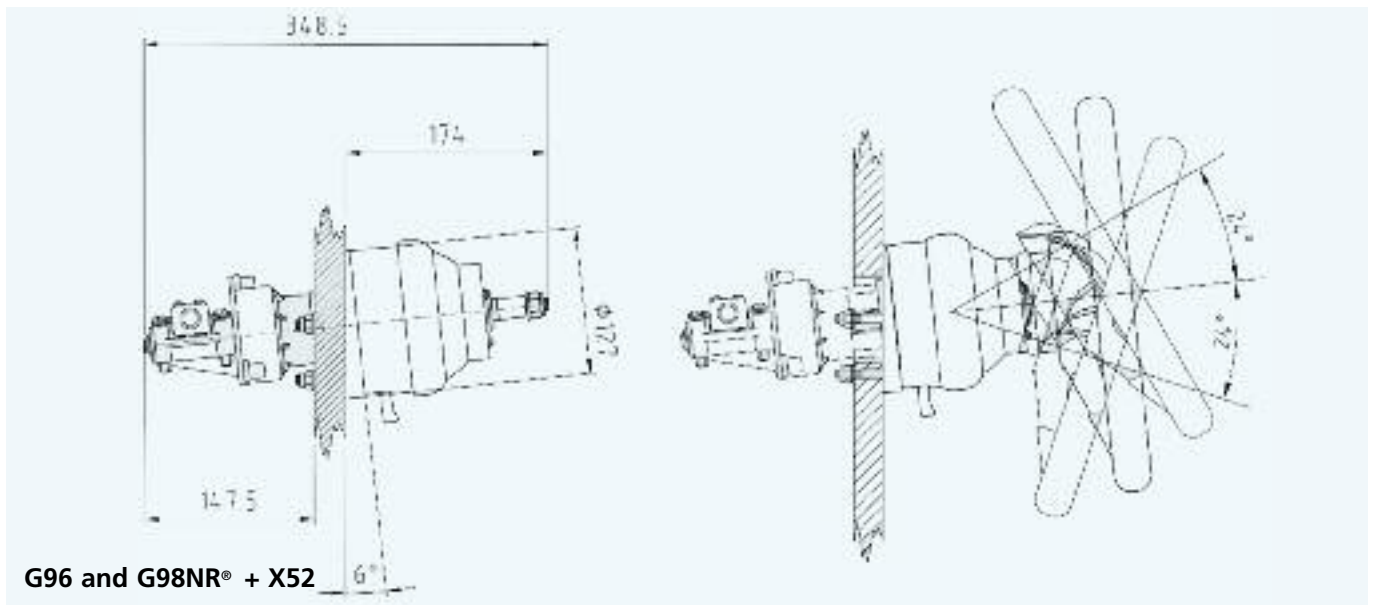

P34 STEERING SYSTEM FOR INFLATABLE BOATS

A COMPLETE STEERING SYSTEM CONSISTS OF:

- Stainless steel, tubular, floor mounted pedestal:
P34 - 36657 E
- Steering helm:
T71FC - 38867 H
- Black mounting bezel:
X34 - 36654 B
- Steering cable: **M66**
- Optional steering wheel (see index)
- Accessories: control box mounting plates and connection kits (see index)

FEATURES AND TECHNICAL SPECIFICATIONS

- Inflatable boats floor anchors
- Stainless steel tubular support with anodized aluminium control box mounting plate
- All stainless steel cable output ends
- Lock-to-lock steering wheel turns: 3,8
- Stroke: 9" (230")
- Maximum allowable steering wheel diameter: 16" (406 mm)
- Minimum steering cable bend radius: 7.9" (200 mm)

- Exceeds EN 28848 safety standards
- Exceeds ABYC P17 safety standards

- APPLICATION: for use with inflatable boats equipped with outboard engines

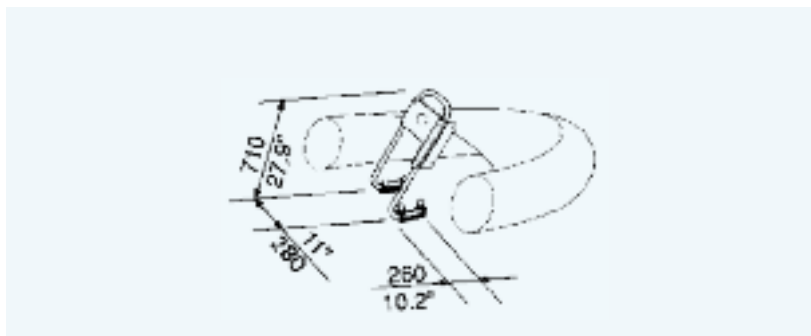
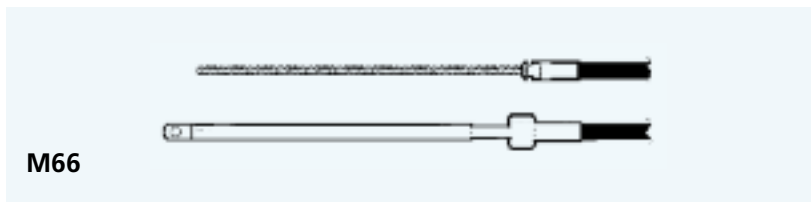
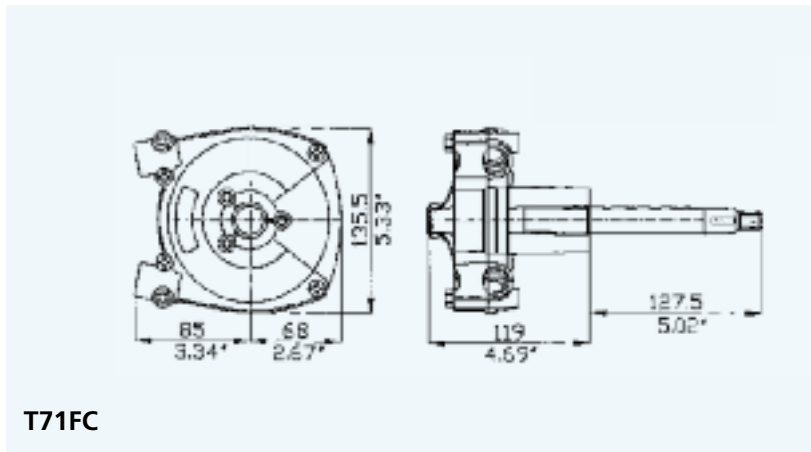

ACCESSORIES FOR MECHANICAL STEERING SYSTEMS

STEERING CABLE SUPPORTS

- S38 - 31971 M**
Stringer mount clamp block in marine aluminium and stainless steel.
- S39 - 31916 F**
Clamp block in marine aluminum and stainless steel
- S40 - 31917 G**
Splashwell mounting, corrosion resistant flange
- S55 - 34744 A**
90° rudder support corrosion resistant bracket.
- S39T - 53930 J**
Aluminum steel tube only for S39
- S40T - 53935 O**
Aluminum steel tube only for S40



S38

S39

S40



S55



OMC-TT

OMC® TT - 39363 H
Thru transom sterndrive steering kit applicable for OMC® sterndrives manufactured from 1968-1982. Connects standard mechanical steering cable to the transom and sterndrive.

ENGINE CONNECTION KIT

- A73SS - 41255 T**
Stainless steel tiller arm for some Mercury® engines
- A74SS - 41256 V**
Stainless steel tiller arm for some Johnson®, Evinrude®, OMC® engines
- A75 - 34459 X**
Clevis



A73SS/A74SS - INOX



A75



WARNING: A73 and A74 tiller arms are recommended for mechanical steering systems only

STEERING CABLE ADAPTORS

- K46 - 35679 L**
Adapts M47 cable to Morse® D290® helm and UFLEX FC helms
- K66 - 38432 Q**
Adapts M66 cable to threaded helms
- 1503**
Adapts GEM®, EDSON® wheels to the Uflex steering shaft



K46



K66



1503

WIRE TYPE STEERING GROMMETS AND RING



R1 B R2 B R3 B

BLACK GROMMETS
R1 B - 38060 I
 Ø 152 mm (6"); h 110 mm (4.3")
R2 B - 38061 J
 Ø 105 mm (4.1"); h 65 mm (2.5")
R3 B - 38062 K
 2 holes Ø 105 mm (4.1"); h 52 mm (2")



R1 W R2 W R3 W

WHITE GROMMETS
R1 W - 38953 A
 Ø 152 mm (6"); h 110 mm (4.3")
R2 W - 38954 C
 Ø 105 mm (4.1"); h 65 mm (2.5")
R3 W - 38955 E
 2 holes Ø 105 mm (4.1"); h 52 mm (2")

TYPICAL INSTALLATIONS

INSTALLATION	CABLE SUPPORT + ENGINE CONNECTION KIT
A	S39 + A75
B	S40 + A75
D	S55 + A75

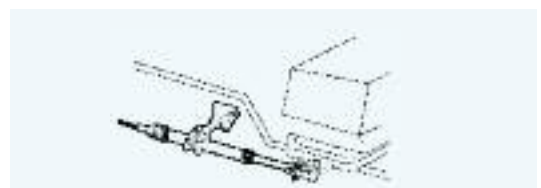

A = With clamp block

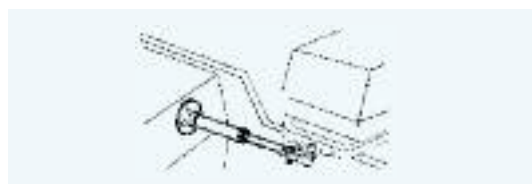

B = With splashwell



D = With 90° rudder support

PACKAGED ROTARY STEERING SYSTEMS

UFLEX ROTARY STEERING SYSTEMS PACKAGED IN A BOX

A convenient kit form, especially suitable as replacement steering, that includes helm, bezel and cable.

The cable is available in 1-ft increments from 6 to 20 feet (specify cable length when ordering)

The wheel is not included

ROTECH™ STEERING SYSTEM

ROTECH -XLL - LL= Length
T71FC - helm
X34 - 90° bezel
M66 - steering cable

ROTECH - II XLL - LL= Length
T72FC - helm-dual
X34 - 90° bezel
M66 - 2 steering cables

Featuring the T71FC helm with a Planetary Gear Design, the Rotech reduces steering effort and delivers more balanced loads on the steering wheel. This unique design also offers a wider wear area which reduces lost motion and improves durability. Centered on the main drive shaft, this helm requires less room behind the dash and is a direct "drop in" replacement for competing system; requiring no new holes for installation. The Rotech package also includes the M66 Universal Rotary Steering Cable with stainless steel output fittings for maximum longevity and smooth steering.

ACCURA™ STEERING SYSTEM

ACCURA - XLL - LL= Length
T73NR FC - helm
X34 - 90° bezel
M66 - steering cable

With a patented spring clutch the Accura eliminates continuous loads on the steering wheel while the direction of the boat is not being actively changed, which is highly recommended for outboard and stern-drives without power assist.

The T73FC helm included with the Accura package also features a Planetary Gear Design for smooth and more balanced steering effort. A direct drop in replacement for competing systems, the Accura also comes with the M66 Universal Rotary Steering Cable with stainless steel output fittings for maximum longevity and smooth steering.



PACKAGED RACK AND PINION STEERING SYSTEMS

UFLEX RACK AND PINION STEERING SYSTEMS PACKAGED IN A BOX

A convenient kit form, especially suitable as replacement steering, that includes helm, bezel and cable.

The cable is available in 1-ft increments from 6 to 20 feet (specify cable length when ordering)

The wheel is not included

RACKTECH™ STEERING SYSTEM

- RACKTECH XLL** - LL= Length
M86 - preassembled helm with steering cable
G86 - shaft assembly
X34 - 90° bezel

The Racktech Rack and Pinion steering package offers a compact installation and features the M86 cable with an armor wrapped stainless steel core for maximum efficiency and minimal lost motion.

Ideal for boats with minimal clearance behind the dash, the Racktech is recommended for power assisted sterndrives and other applications with minimal rudder torque.

ACCUTECH™ STEERING SYSTEM

- ACCUTECH XLL** - LL= Length
M86 - preassembled helm with steering cable
G88NR® - non-reversible shaft assembly
X34 - 90° bezel

Recommended for outboard applications or non power assisted sterndrives where there is limited space behind the dash, the Accutech features a patented spring clutch of the G88NR helm eliminates continuous loads while not actively changing direction.

The M86 cable included with the Accutech has an armor wrapped stainless steel core for maximum efficiency and minimal lost motion.





HYDRAULIC STEERING SYSTEMS

WARNING If the steering system can only be repaired by a qualified technician, the vehicle should be towed to a qualified repair shop. Do not attempt to repair the steering system. Failure to comply with the instructions may result in personal injury, and death.

ULTRAFLEX HYDRAULIC STEERING SYSTEMS

All the components of Ultraflex hydraulic steering systems are made specifically for the marine environment, using materials and working process which offer long life and safety for the most extreme conditions.

HOW THE SYSTEM WORKS

A manual hydraulic steering system consists of a helm which pumps hydraulic fluid through two hoses to a hydraulic cylinder which is mounted to an engine or rudder.

While steering, hydraulic oil is pushed through hoses into two chambers within the hydraulic cylinder. Depending upon which direction you steer, one of the two chambers is filled or relieved of oil, thereby changing the course of the boat.

While not actively steering, the torque (hydraulic pressure in the hoses) is held by a one way valve in the helm, which eliminates the transmission of the torque "feedback" to the steering wheel.

The number of turns from full lock-to-lock has a relationship to ease of steering. Generally speaking, the more number of turns lock-to-lock the easier the boat will be to steer and vice versa.

Because of the variety of applications and handling characteristics of boats, the number of turns lock to lock is often a matter of personal preference. As a general rule, the first priority should be ease of steering, then number of turns lock to lock. However, it is not recommended to have fewer than 4 turns lock to lock on high performance boats.

To calculate number of turns lock to lock simply divide the cubic inch displacement of the cylinder by the cubic inch displacement of the helm.

Other factors that can significantly affect the amount of effort to steer the system can be:

- Fittings introduced between the helm and cylinder that restrict fluid efficiency
- Oil viscosity
- Type of hose and inside hose diameter.
- Vessel speed
- Trim angle
- Rudder dimension, or engine power
- Propeller selection
- Hull type (displacement, planing, etc.)
- Sea conditions



SINGLE STEERING STATION INSTALLATION DIAGRAM

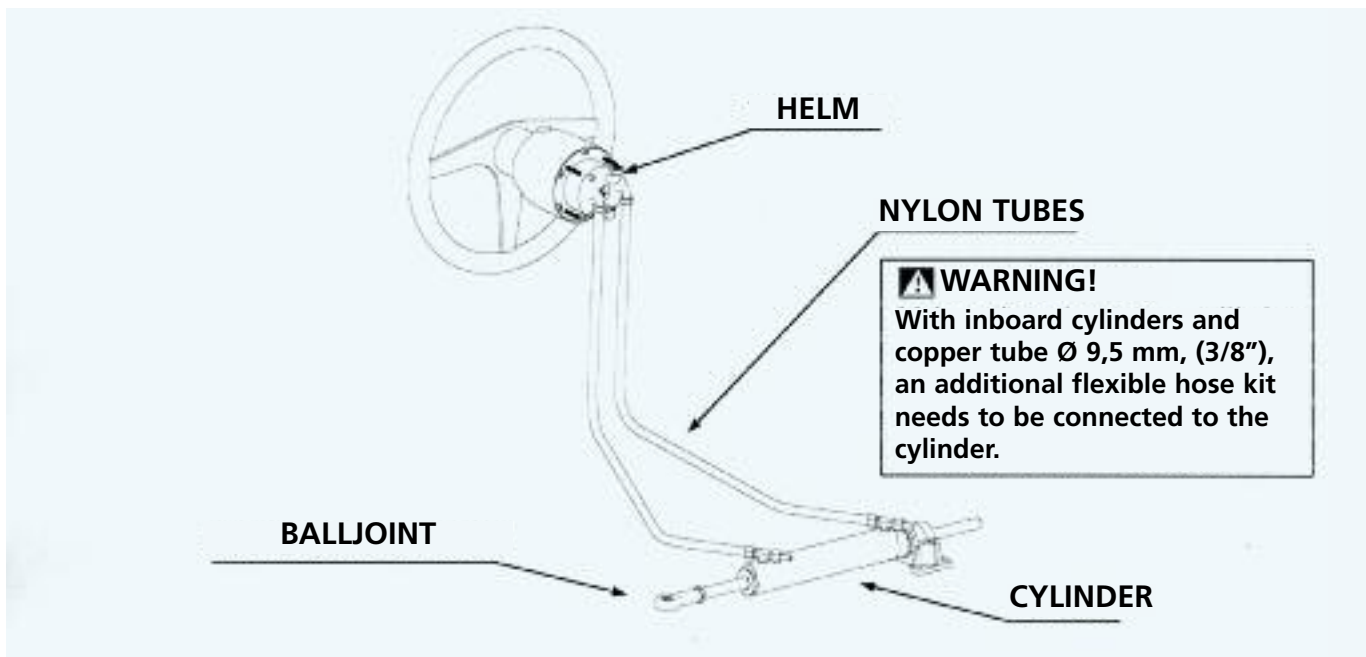

DUAL STEERING STATION INSTALLATION DIAGRAM

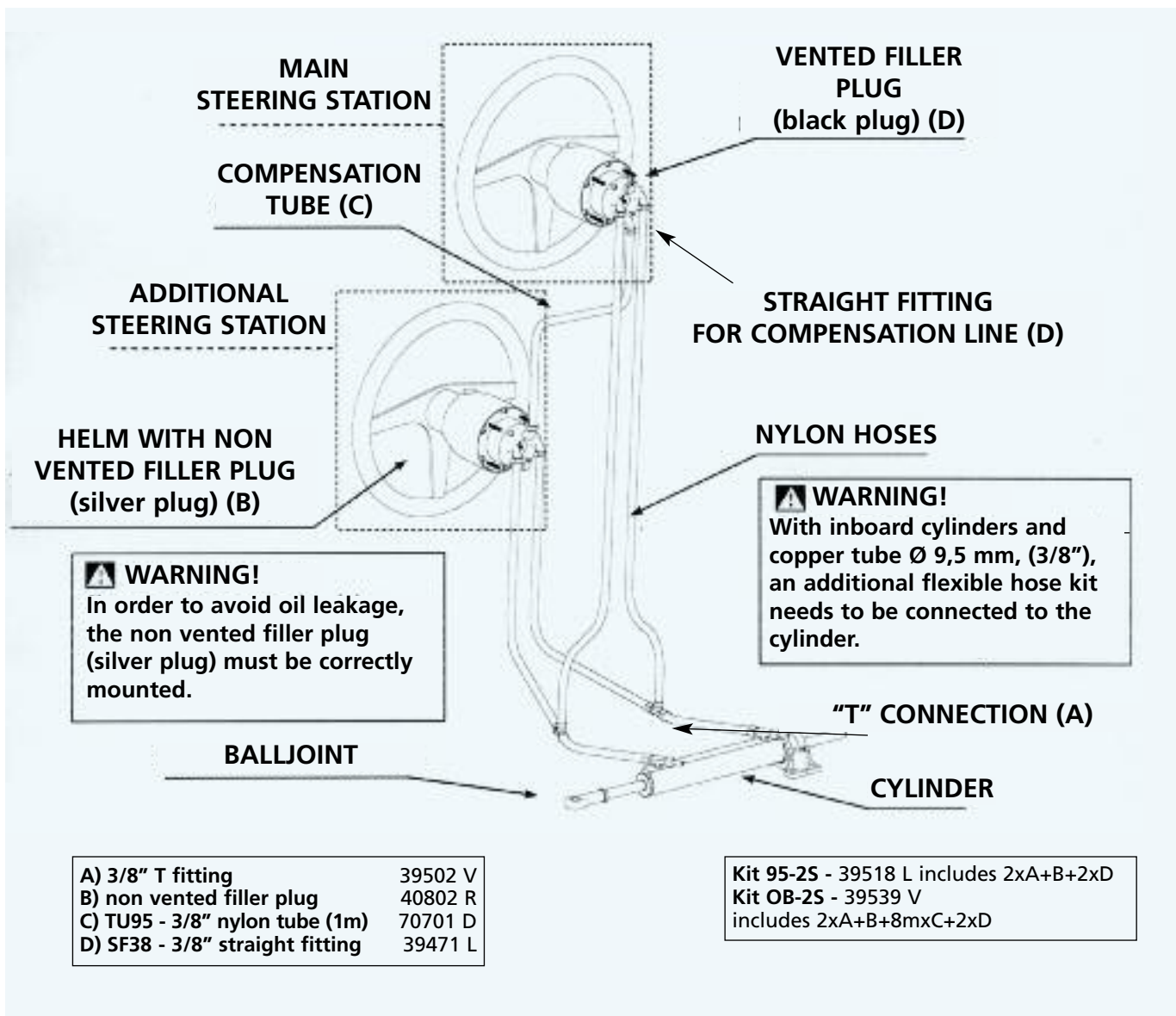

SUGGESTIONS AND WARNINGS WHEN SELECTING A HYDRAULIC STEERING SYSTEM



34

OUTBOARD CYLINDERS Maximum power rating applicable

Cylinder model	Single engine single cylinder	Double engine single cylinder		Double engine double cylinder	
		NON counter rotating propellers	Counter rotating propellers	NON counter rotating propellers	Counter rotating propellers
	Power max hp	Power max hp	Power max hp	Power max hp	Power max hp
UC94-OBF	150	not applicable	not applicable	not applicable	not applicable
UC128-OBF	300	300	500	500	600
UC128-SVS	350	350	600	600	700
UC132-OBS	300	300	450	500	600

WARNING: These recommendations should be used as a general reference only. Final selection should be made with the assistance of a qualified installation technician. For any further information please contact our Technical Service

STEERING WHEEL TURNS single cylinder

	UP20 20cc	UP25 25cc	UP28 28cc	UP33 33cc	UP 39 39cc	UP45 45 cc	UP28-SVS 28cc	UP33-SVS 33cc	UP39-SVS 39cc
UC94-OBF	4,7	-	-	-	-	-	-	-	-
UC128-OBF	-	4,8	4,3	3,6	3,1	-	-	-	-
UC128-SVS	-	-	-	-	-	-	4,3	3,6	3,1
UC132-OBS	-	5,3/6,5	4,7/5,8	4,0/4,9	3,4/4,2	2,9/3,6	-	-	-
UC133-IOB	-	5,6	4,7	4,0	3,4	2,9	-	-	-
UC69-I	3,5	-	-	-	-	-	-	-	-
UC116-I	-	4,6	4,1	3,5	3,0	-	-	-	-
UC168-I	-	6,7	6,0	5,1	4,3	3,7	-	-	-
UC215-I	-	8,6	7,7	6,5	5,5	-	-	-	-
UC293-I	-	-	-	8,9	7,5	6,5	-	-	-
UC378-I	-	-	-	-	9,7	8,4	-	-	-

Suggested

STEERING WHEEL TURNS double cylinder

	UP28 28cc	UP33 33cc	UP39 39cc	UP45 45cc	UP33-SVS 33cc	UP39-SVS 39cc
UC128-OBF	-	7,3	6,2	5,3	-	-
UC128-SVS	-	-	-	-	7,3	6,2
UC132-OBS	-	8,0/9,8	6,8/8,4	5,8/7,2	-	-
UC133-IOB	-	8,0	6,8	5,8	-	-
UC116-I	8,2	7,0	6,0	5,2	-	-
UC168-I	-	-	8,6	7,4	-	-
UC215-I	-	-	-	9,5	-	-

Suggested

UP20 F - UP20 T HELM PUMPS



FEATURES

- Built-in lock valve for positive rudder lock
 - Integral relief valve for over-pressure protection
 - 3/4" tapered anodized aluminum shaft
 - Corrosion proof composite housing
 - Easy accessible lock valve and shaft seal for replacement
 - Includes elbow fittings for 3/8" tube
 - For use with UC94-OBF, UC68-OBS and UC69-I cylinders only
 - Tilt mechanism **X52** - 39250 U for UP20 T pump
Tilt range of 48° and five locking positions
- NOTE:** X52 tilt mechanism fits standard Ultraflex tilt mount rotary and rack and pinion steering helms as well as standard Ultraflex tilt mount hydraulic pumps. On high performance ~~systems~~ systems use **X70-SVS** tilt mechanism
- **X56** - 40198 C square flange permits to install the UP20F pump in an intermediate dashboard position



UP20 F



UP20 T + X52



UP20 F + X56

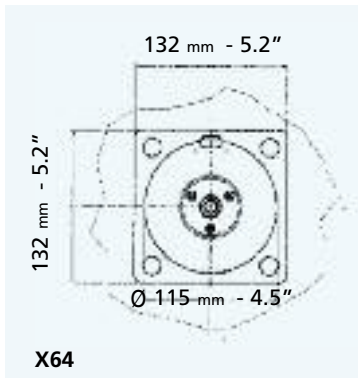

MOD.	P. No.	MOUNTING	DISPLACEMENT/ REVOLUTION	No. OF PISTONS	RELIEF VALVE SETTING	MAXIMUM WHEEL DIA.	WEIGHT
UP20 F	37939 U	Front mount	20 cc - 1.2 cu. in	5	70 Bar - 1000 PSI	508 mm - 20"	3,6 kg - 8 lbs
UP20 T	40153 D	With X52 tilt	20 cc - 1.2 cu. in	5	70 Bar - 1000 PSI	406 mm - 16"	3,9 kg - 8.5 lbs

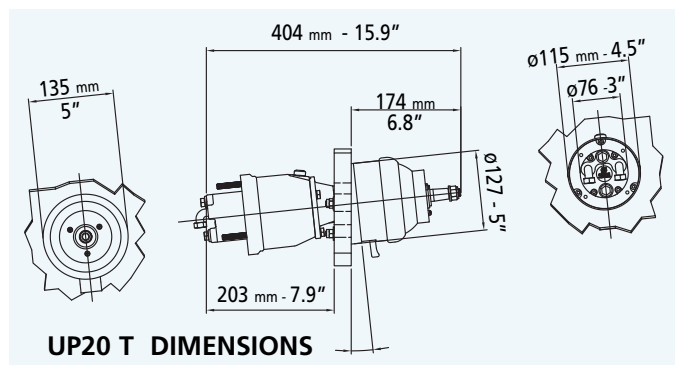
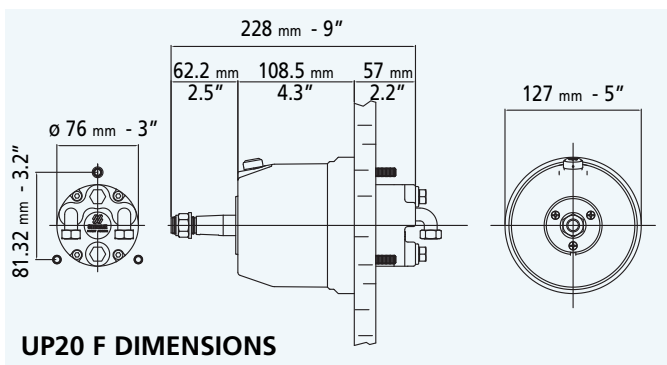



UP25 F - UP28 F
UP33 F - UP39 F
UP45 F
FRONT MOUNT HELM PUMPS



36

FEATURES

- Available in five different displacement sizes
- Compact design
- Ball bearing piston race
- Built-in lock valve for positive rudder lock (except UP25 NV F and UP33NV F)
- Integral relief valve for over-pressure protection
- 3/4" tapered stainless steel shaft
- Easily accessible lock valve and shaft seal for replacement
- Cast iron rotor for greater durability and longer life
- 1/4" NPT fitting for 3/8" tube
- Includes elbow fittings
- **UP45 F** pump is ideal for double cylinder applications
- Direct "drop-in" replacement for competing helms
- **X56** - 40198 C square flange or **X57** - 39464 P round flange permit to install the pumps in an intermediate dashboard position.



UP25 F/28 F/33 F/39 F/45 F + X56



UP25 F/28 F/33 F/39 F/45 F + X57

FRONT MOUNT HELM PUMPS

MOD.	P. No.	MOUNTING	DISPLACEMENT/ REVOLUTION	No. OF PISTONS	RELIEF VALVE SETTING	MAXIMUM WHEEL DIA.	WEIGHT
UP25 F	39618 R	Front mount	25 cc - 1.5 cu.in	5	70 Bar - 1000 PSI	710 mm - 28"	5 kg - 11 lbs
UP28 F	39443 F	Front mount	28 cc - 1.7 cu.in	5	70 Bar - 1000 PSI	710 mm - 28"	5 kg - 11 lbs
UP33 F	39422 X	Front mount	33 cc - 2.0 cu.in	7	70 Bar - 1000 PSI	710 mm - 28"	5 kg - 11 lbs
UP39 F	39415 A	Front mount	39 cc - 2.4 cu.in	7	70 Bar - 1000 PSI	710 mm - 28"	5 kg - 11 lbs
UP45 F	41276 B	Front mount	45 cc - 2.7 cu.in	7	70 Bar - 1000 PSI	710 mm - 28"	5 kg - 11 lbs

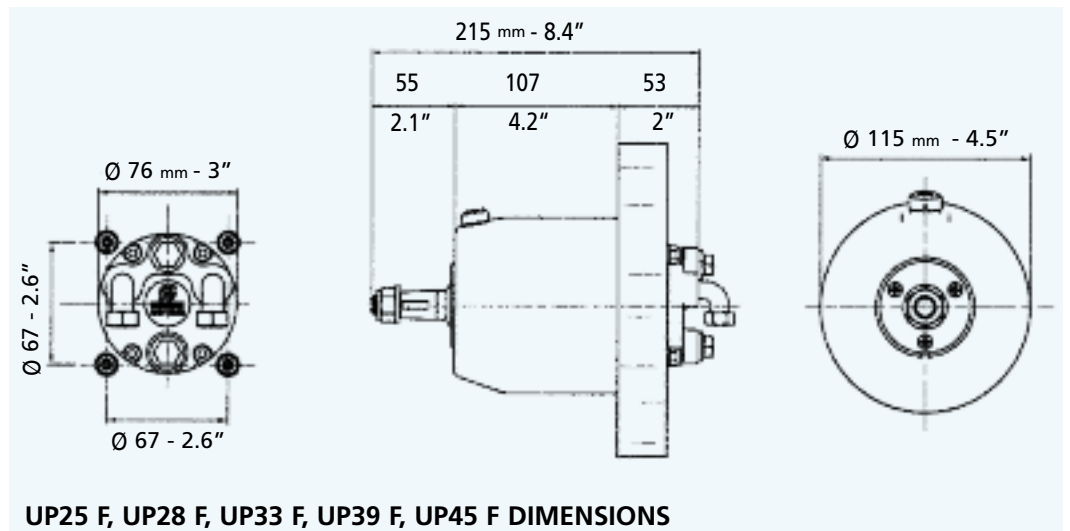
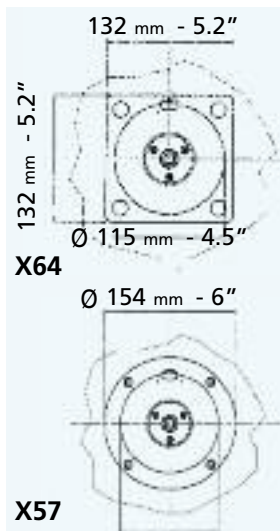

UP25 T - UP28 T - UP33 T
UP39 T - UP45 T
TILT MOUNT HELM PUMPS

FEATURES

- Available in five different displacement sizes
- Compact design
- Ball bearing piston race
- Built-in lock valve for positive rudder lock
- Integral relief valve for over-pressure protection
- Stainless steel shaft
- Easily accessible lock valve and shaft seal for replacement
- Cast iron rotor for greater durability and longer life
- 1/4" NPT fitting for 3/8" tube
- Includes elbow fittings
- **UP45 T** pump is ideal for double cylinder applications
- Direct "drop-in" replacement for competing helms
- Tilt mechanism:
X52 - 39250 U
 Tilt range of 48° and five locking positions
NOTE: X52 tilt mechanism fits standard Ultraflex tilt mount rotary and rack and pinion steering helms as well as standard Ultraflex tilt mount hydraulic pumps. On high performance ~~Ultraflex~~ systems use **X70-SVS** tilt mechanism
- **KIT F** (optional) - 39664 Y Remote fill adapter



37



MOD.	P. No.	MOUNTING	DISPLACEMENT/ REVOLUTION	No. OF PISTONS	RELIEF VALVE SETTING	MAXIMUM WHEEL DIA.	WEIGHT
UP25 T	40803 T	With X52 tilt	25 cc - 1.5 cu.in	5	70 Bar - 1000 PSI	406 mm - 16"	5 kg - 11 lbs
UP28 T	39445 K	With X52 tilt	28 cc - 1.7 cu.in	5	70 Bar - 1000 PSI	406 mm - 16"	5 kg - 11 lbs
UP33 T	39446 M	With X52 tilt	33 cc - 2.0 cu.in	7	70 Bar - 1000 PSI	406 mm - 16"	5 kg - 11 lbs
UP39 T	39447 P	With X52 tilt	39 cc - 2.4 cu.in	7	70 Bar - 1000 PSI	406 mm - 16"	5 kg - 11 lbs
UP45 T	41277 D	With X52 tilt	45 cc - 2.7 cu.in	7	70 Bar - 1000 PSI	406 mm - 16"	5 kg - 11 lbs

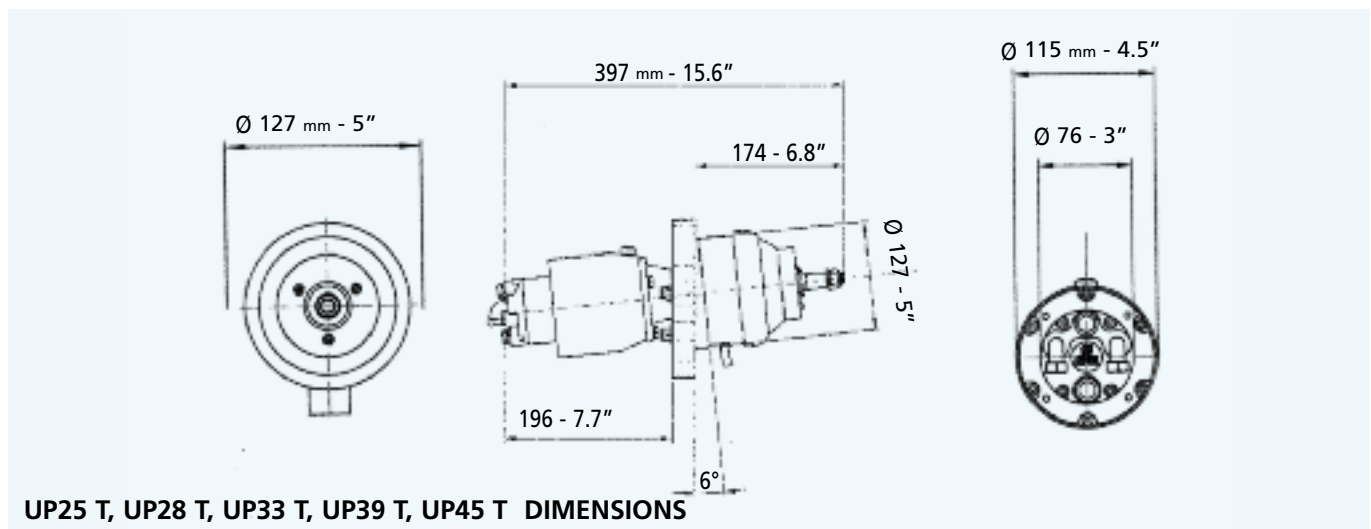



**UP28 R - UP33 R - UP39 R
UP45 R
REAR MOUNT
HELM PUMPS**

FEATURES

- Available in four different displacement sizes
- Compact design
- Ball bearing piston race
- Built-in lock valve for positive rudder lock
- Integral relief valve for over-pressure protection
- 3/4" tapered stainless steel shaft
- Easily accessible lock valve and shaft seal for replacement
- Cast iron cylinder rotor for greater durability and longer life
- 1/4" NPT fitting for 3/8" tube
- Includes elbow fittings and white bezel
- **UP45 R** pumps is ideal for double cylinder applications
- **X68** (optional) - 40894 Z Chrome bezel
- **KIT F** (optional) - 39664 Y Remote fill adapter



KIT F



X68

MOD.	P. No.	MOUNTING	DISPLACEMENT/ REVOLUTION	No. OF PISTONS	RELIEF VALVE SETTING	MAXIMUM WHEEL DIA.	WEIGHT
UP28 R	39970 F	Rear mount	28 cc - 1.7 cu.in	5	70 Bar - 1000 PSI	710 mm - 28"	5 kg - 11 lbs
UP33 R	39969 X	Rear mount	33 cc - 2.0 cu.in	7	70 Bar - 1000 PSI	710 mm - 28"	5 kg - 11 lbs
UP39 R	39444 H	Rear mount	39 cc - 2.4 cu.in	7	70 Bar - 1000 PSI	710 mm - 28"	5 kg - 11 lbs
UP45 R	41278 F	Rear mount	45 cc - 2.7 cu.in	7	70 Bar - 1000 PSI	710 mm - 28"	5 kg - 11 lbs

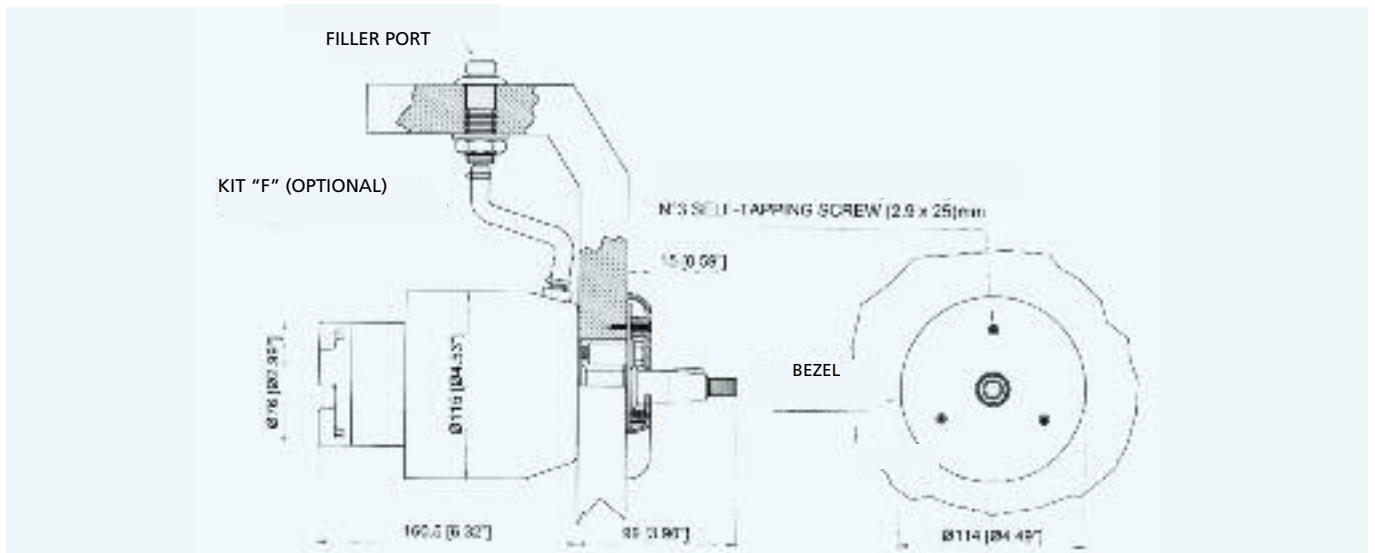

UP28 R, UP33 R, UP39 R, UP45 R DIMENSIONS

**UC94-OBF
FRONT MOUNT
CYLINDER FOR
OUTBOARD
ENGINES
UP TO 150 HP
TOTAL**



UC94-OBF - Balanced: the number of turns lock-to-lock is equal port to starboard or vice-versa

**Adjustable boss style fittings for easy installation
High resistance stainless steel connection bolt (ULTRABOLT)**

Intended for single engine applications of 150 HP and under, the UC94 cylinder is compatible with competing helms, hoses and oil, and is built to last with heavy duty stainless steel cylinder rod, seals and link assemblies. Constructed of top grade materials this cylinder is simple to install and fits almost every two and four stroke outboard engine in the market. See the application guide next page to ensure compatibility with your engine. The UC94 is recommended for use with the UP20 series helm and pre-made hose kits (Kit OB and Kit OB-BHBR).

INNOVATIVE DESIGN (PATENTED):

Split and pinned mounting rod for easy installation and bushings to prevent friction with engine tilt tube.

Depending on the applications on the outboard engines, the UC94-OBF cylinder is available in 2 versions:

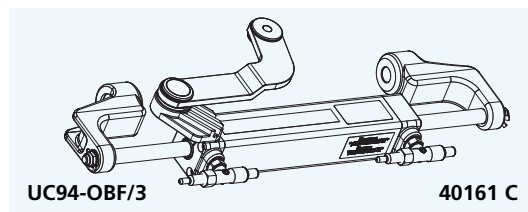
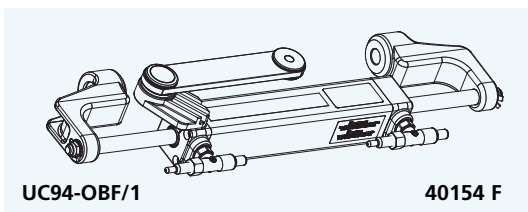

SPECIFICATIONS	UC94-OBF/1 -/3
Volume	94 cc - 5.7 cu. in
Output force	278 kg - 613 lbs
Inside diameter	30 mm - 1.18"
Stroke	186 mm - 7.3"
3/8" (9.5mm) Fittings	For high pressure flex hose
Bleed fittings	DN5 Quick connect

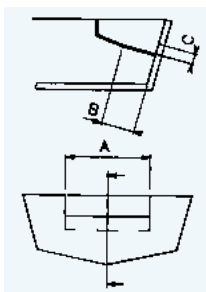
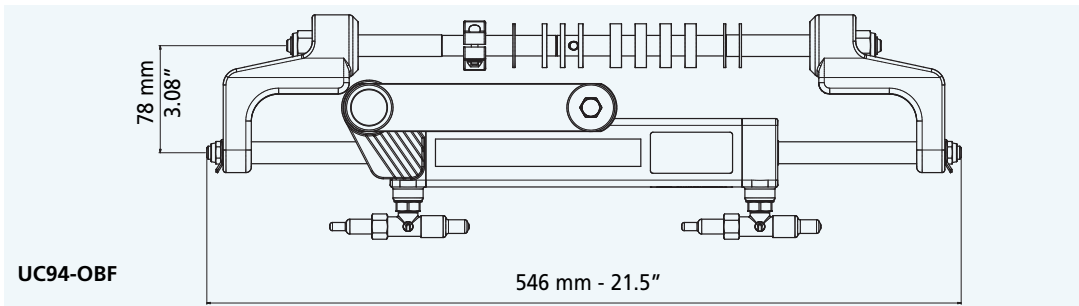

SPLASHWELL DIMENSION REQUIREMENTS			
Engine No.	A	B	C
1	540 mm - 21.25"	152 mm - 5.98"	152 mm - 5.98"
2	1110 mm - 43.70"	152 mm - 5.98"	152 mm - 5.98"

For twin engine applications, the minimum distance between the two engine centers is 21.6" (550 mm)



40

**UC94-OBF
CYLINDER
APPLICATIONS**

WARNING

The UC94-OBF front mount cylinder is recommended for use with outboard engines 150 hp total and less and where the boat speed does not exceed 40 mph (40 knots)

Not intended for use in racing application

WARNING

These recommendations should be used as a general reference only. For any further information please contact our Technical Service.

ENGINE	POWER	YEAR	CYLINDER	P. No.	PACKAGED
Mercury® Mariner®	50 – 75 – 90 2 Stroke	1990-2008	UC94-OBF/1	40154 F	HYCO 1
	115 – 125 – 150 EFI 2 Stroke	1990-2007	UC94-OBF/1	40154 F	HYCO 1
	75 – 90 – 115 - 125 Optimax 2 Stroke	2004-to date	UC94-OBF/3	40161 C	HYCO 3
	135 – 150 Optimax 2 Stroke	1999-to date	UC94-OBF/1	40154 F	HYCO 1
	40 – 50 – 60 EFI 4 Stroke	2004-to date	UC94-OBF/1	40154 F	HYCO 1
	75 – 80 – 90 EFI 4 Stroke	2000-to date	UC94-OBF/1	40154 F	HYCO 1
	100 – 115 EFI 4 Stroke	2007-to date	UC94-OBF/1	40154 F	HYCO 1
Evinrude®	E40-E50-E55-E60 2 Stroke	2004-to date	UC94-OBF/1	40154 F	HYCO 1
	E75-E90 2 Stroke	2004-to date	UC94-OBF/1	40154 F	HYCO 1
	E115-E130-E135 2 Stroke V4	1995-to date	UC94-OBF/1	40154 F	HYCO 1
	E150 2 Stroke V6	1995-to date	UC94-OBF/1	40154 F	HYCO 1
Yamaha®	60-70 2 Stroke	1984-2008	UC94-OBF/1	40154 F	HYCO 1
	75C-90 2 Stroke	1998-2008	UC94-OBF/1	40154 F	HYCO 1
	115C-130B 2 Stroke	1990-2008	UC94-OBF/1	40154 F	HYCO 1
	150F	1996-2007	UC94-OBF/1	40154 F	HYCO 1
	150 HPDI VMAX 2 Stroke	2000-2008	UC94-OBF/1	40154 F	HYCO 1
	F60-F75-F80 EFI 4 Stroke	1999-2007	UC94-OBF/1	40154 F	HYCO 1
	F90-F100-F115-F150 EFI 4 Stroke	1999-2007	UC94-OBF/1	40154 F	HYCO 1
	F80-F100 4 Stroke	2000-to date	UC94-OBF/1	40154 F	HYCO 1
	F115-F150	2004-to date	UC94-OBF/1	40154 F	HYCO 1
Honda®	BF75-BF90 4 Stroke	1995-to date	UC94-OBF/1	40154 F	HYCO 1
	BF115D	1998-2009	UC94-OBF/3	40161C	HYCO 3
	BF115A	2009-to date	UC94-OBF/1	40154 F	HYCO 1
	BF130A	1998-2005	UC94-OBF/3	40161C	HYCO 3
	BF135-BF150 4 Stroke	2005-to date	UC94-OBF/1	40154 F	HYCO 1
	BF90-BF150 V-TEC 4 Stroke	2008-to date	UC94-OBF/1	40154 F	HYCO 1
Suzuki®	DF70-80-90 4 Stroke	1998-to date	UC94-OBF/1	40154 F	HYCO 1
	DF100-115-140 4 Stroke*	1998-2008	UC94-OBF/1*	40154 F	HYCO 1
	DF100-115-140 4 Stroke new model	2008-to date	UC94-OBF/1	40154 F	HYCO 1
	DF150 4 Stroke	2006-to date	UC94-OBF/1	40154 F	HYCO 1
Tohatsu® Nissan®	50-60-70-90 2 Stroke	2004-to date	UC94-OBF/1	40154 F	HYCO 1
	115-120-140 2 Stroke	2004-to date	UC94-OBF/1	40154 F	HYCO 1
	40-50TLDI 4 Stroke	2004-to date	UC94-OBF/1	40154 F	HYCO 1
	70-90-115 TLDI 4 Stroke	2004-to date	UC94-OBF/1	40154 F	HYCO 1
Selva®	50 Madeira/ Bull shark-60 Grey Shark/St.tropez- 70 Mako Shark 2 Stroke	1995-2008	UC94-OBF/1	40154 F	HYCO 1
	80 Portofino/Tigershark 2 Stroke	2001-2007	UC94-OBF/1	40154 F	HYCO 1
	150 White Shark 2 Stroke		UC94-OBF/1	40154 F	HYCO 1
	50-60 Dorado efi 4 Stroke		UC94-OBF/1	40154 F	HYCO 1
	100 EFI Marlin -115 EFI Narwhal-150EFI Killer Whale 4 Stroke	2000-to date	UC94-OBF/1	40154 F	HYCO 1
Johnson®	BJ60-70 4 Stroke	2001-2007	UC94-OBF/1	40154 F	HYCO 1
	BJ90-115-140 4 Stroke	2001-2007	UC94-OBF/1	40154 F	HYCO 1
	J90-115 V4 2 Stroke	1995-2007	UC94-OBF/1	40154 F	HYCO 1

***NOTE:**

Suzuki® engines built from 1998 to 2008 installing UC94-OBF/1 cylinder require optional KIT SU - 41954W.



UC94-OBF/1 on SUZUKI® 150 HP



UC94-OBF/1 on HONDA® 150 HP

UC128-OBF
FRONT
MOUNT
CYLINDER



UC128-OBF - Balanced: the number of turns lock-to-lock is equal port to starboard or vice-versa

Adjustable boss style fittings for easy and leak free installation
High resistance stainless steel connection bolt (ULTRABOLT)

Compatible with competing helms, hoses and oil, the UC128 cylinder is built to last with heavy duty stainless steel cylinder rod, seals and link assemblies. Constructed of top grade materials this cylinder is simple to install and fits almost every two and four stroke outboard engine in the market. See the application guide next page to choose the appropriate cylinder (UC128-OBF/1, UC128-OBF/2 or UC128-OBF/3) for your application. The UC128 cylinders are recommended for use with UP25, UP28, UP33 and UP39 series helms and preassembled hoses (Kit OB and Kit OB-BHBR). Depending on the applications on the outboard engines, the UC128-OBF is available in 3 versions:

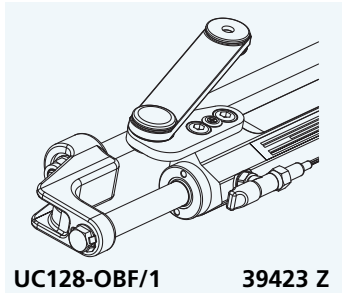

UC128-OBF/1 39423 Z

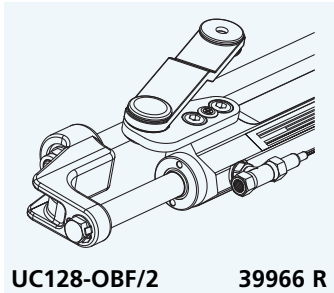

UC128-OBF/2 39966 R

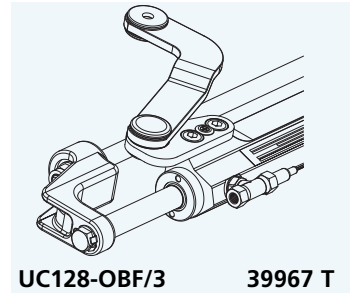

UC128-OBF/3 39967 T

In the applications with dual UC128-OBF cylinder it is necessary to order a standard UC128-OBF cylinder (link arm attached to the starboard side of the cylinder) and a port UC128P-OBF cylinder (link arm attached to the port side of the cylinder). See appropriate section for A90 tie bar required for use on dual engine/dual cylinder applications.

Depending on the applications on the outboard engines, the UC128P-OBF port cylinder is available in 2 versions:



UC128P-OBF

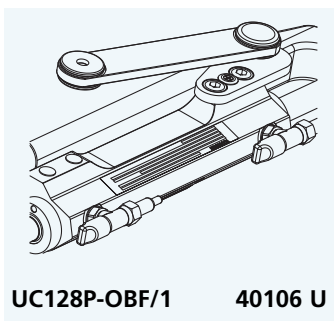

UC128P-OBF/1 40106 U

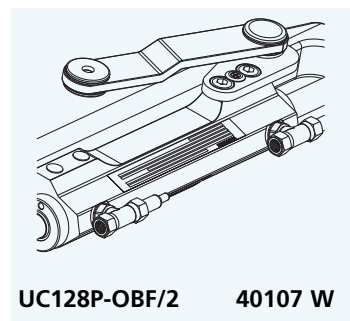

UC128P-OBF/2 40107 W

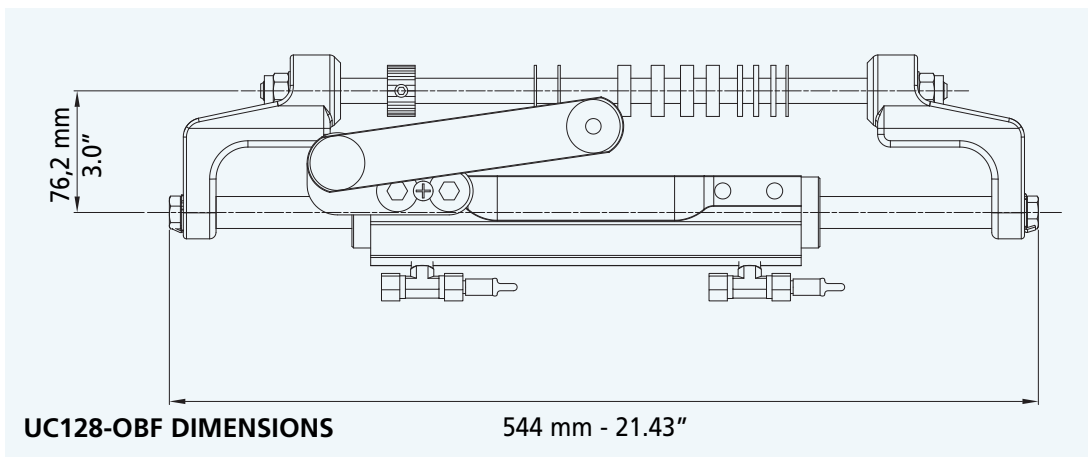

UC128-OBF DIMENSIONS

544 mm - 21.43"



UC128-OBF

FRONT

MOUNT

CYLINDER

SPECIFICATIONS	UC128-OBF/1 -/2 -/3
Volume	120 cc - 7.3 cu. in
Output force	450 kg - 992 lbs
Inside diameter	35 mm - 1.37"
Stroke	185 mm - 7.28"
3/8" (9,5 mm) Fittings	For high pressure flex hose
Bleed fittings	DN5 Quick connect

SPLASHWELL DIMENSION REQUIREMENTS

Engine No.	A	B	C
1	560 mm - 22.05"	152 mm - 5.98"	152 mm - 5.98"
2	1110 mm - 43.70"	152 mm - 5.98"	152 mm - 5.98"

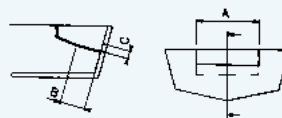

For twin engine applications minimum engine center distance is 21.6" (550 mm)

42

UC128-OBF

CYLINDER

APPLICATIONS

ENGINE	MODEL	YEAR	CYLINDER	P. NO.	PACKAGED
Mercury® Mariner®	75-90-115-125 Optimax 2 Stroke	2004-to date	UC128-OBF/3	39967 T	PROTECH 3
	135-150-175 Optimax 2 Stroke	1999-to date	UC128-OBF/1	39423 Z	PROTECH 1
	200-225-250 Optimax 2 Stroke	1999-to date	UC128-OBF/1	39423 Z	PROTECH 1
	RACING 300 Optimax 2 Stroke		UC128-OBF/1	39423 Z	PROTECH 1
	100-115 EFI 4 Stroke	2007-to date	UC128-OBF/1	39423 Z	PROTECH 1
	115-125-150 EFI 2 Stroke	1990-2007	UC128-OBF/1	39423 Z	PROTECH 1
	225-250 EFI 2 Stroke	2000-2007	UC128-OBF/1	39423 Z	PROTECH 1
	250 Saltwater EFI 4 Stroke	2004-2006	UC128-OBF/1	39423 Z	PROTECH 1
135-150-175-200 Verado L4 4 Stroke		UC128-OBF/1	39423 Z	PROTECH 1	
Evinrude®	E75-E90 2 Stroke	2004-to date	UC128-OBF/2	39966 R	PROTECH 2
	E115-E130-E135 2 Stroke V4	1995-to date	UC128-OBF/2	39966 R	PROTECH 2
	E150-E175-E200 2 Stroke V6	1995-to date	UC128-OBF/2	39966 R	PROTECH 2
	E200 HO- E225-E250 2 Stroke V6	1995-to date	UC128-OBF/2	39966 R	PROTECH 2
	E250 HO- E300 2 Stroke V6		UC128-OBF/2	39966 R	PROTECH 2
Yamaha®	75C-90 2 Stroke	1998-2008	UC128-OBF/2	39966 R	PROTECH 2
	115C-130B 2 Stroke	1990-2008	UC128-OBF/2	39966 R	PROTECH 2
	150F-200F-250G 2 Stroke	1996-2007	UC128-OBF/2	39966 R	PROTECH 2
	150 HPDI VMAX 2 Stroke	2000-2008	UC128-OBF/2	39966 R	PROTECH 2
	175-200-225-250-300 HPDI VMAX 2 St.	2000-2008	UC128-OBF/2	39966 R	PROTECH 2
	F70 4 Stroke	2010-to date	UC128P-OBF/1	40106U	-
	F90-F100-F115-F150 EFI 4 Stroke	1999-2007	UC128-OBF/1	39423 Z	PROTECH 1
	F200-F225-F250 4 Stroke	2002-2007	UC128-OBF/2	39966 R	PROTECH 2
	F115-F150	2004-to date	UC128-OBF/1	39423 Z	PROTECH 1
	F200-F225-F250-F300 4 Stroke	2006-to date	UC128-OBF/2	39966 R	PROTECH 2
F350 4 Stroke	2008-to date	see UC128-SVS	SilverSteer	-	
Honda®	BF75-90 4 Stroke	1995-to date	UC128-OBF/1	39423 Z	PROTECH 1
	BF115D	1998-2009	UC128-OBF/3	39967 T	PROTECH 3
	BF115A	2009-to date	UC128-OBF/1	39423 Z	PROTECH 1
	BF130A	1998-2005	UC128-OBF/3	39967 T	PROTECH 3
	BF135-150 4 Stroke	2005-to date	UC128-OBF/1	39423 Z	PROTECH 1
	BF90-BF150 V-TEC 4 Stroke	2008-to date	UC128-OBF/1	39423 Z	PROTECH 1
BF175-200-225 4 Stroke	2001-to date	UC128-OBF/1	39423 Z	PROTECH 1	
Suzuki®	DF70-80-90 4 Stroke	1998-to date	UC128-OBF/2	39966 R	PROTECH 2
	DF100-115-140 4 Stroke*	1998-2008	UC128-OBF/1*	39423 Z	PROTECH 1
	DF100-115-140 4 Stroke new model	2008-to date	UC128-OBF/1	39423 Z	PROTECH 1
	DF150-175 4 Stroke	2006-to date	UC128-OBF/1	39423 Z	PROTECH 1
	DF200-DF225-DF250-DF300		UC128-OBF/2	39966 R	PROTECH 2
Tohatsu®	115-120-140 2 Stroke	2004-to date	UC128-OBF/2	39966 R	PROTECH 2
	70-90-115 TLDI 4 Stroke	2004-to date	UC128-OBF/1	39423 Z	PROTECH 1
Selva®	80 Portofino/Tigershark 2 Stroke	1995-to date	UC128-OBF/1	39423 Z	PROTECH 1
	150 White Shark 2 Stroke				
	100EFI Marlin -115 EFI Narwhal-150EFI Killer Whale 4 Stroke	2001-2007 2000-to date	UC128-OBF/2 UC128-OBF/1	39966 R 39423 Z	PROTECH 2 PROTECH 1
Johnson®	BJ90-115-140 4 Stroke	2001-2007	UC128-OBF/1	39423 Z	PROTECH 1
	J90-115 V4 2 Stroke	1995-2007	UC128-OBF/2	39966 R	PROTECH 2
	J150-175 V6 2 Stroke	1995-2007	UC128-OBF/2	39966 R	PROTECH 2
	J200-225 V6 4 Stroke	2004-2007	UC128-OBF/2	39966 R	PROTECH 2

*NOTE:

Suzuki® engines built from 1998 to 2008 installing UC128-OBF/1 cylinder require optional **KIT SU - 41954W**. For higher horsepower applications, high performance SilverSteer™ cylinder is recommended.

**UC128-OBF
CYLINDER**

ORDER GUIDE:

SYSTEM	APPLICATION	WHEEL TURNS	COMPONENTS	MODEL	QTY
Single engine Single cylinder 	Up to 300 hp max	4,8 (UP25)	Cylinder Helm pump Hose Kit	UC128-OBF UP25 or UP28 KIT OB	1 1 1
		4,3 (UP28)	Oil Steering wheel	OIL 15 (Wheel selection)	2 1

For a second station add:
1 UP25 or UP28 helm pump, 1 KIT OB-25 fitting kit, 1 KIT OB, 1 OIL 15, 1 steering wheel

WARNING

The UC128-OBF front mount cylinder is not recommended for use in installations where the boat speed exceeds **50 mph (50 knots)** (60 mph (60 knots) in dual engine, dual cylinder and counter rotating engines application). Not intended for use in racing application.

NOTE:

For high performance applications SilverSteer™ systems are recommended.

Dual engine Single cylinder 	Up to 300 hp max (non-counter rotating engine)	4,8 (UP25)	Cylinder Helm pump Hose Kit	UC128-OBF UP25 or UP28 KIT OB	1 1 1
		4,3 (UP28)	Oil Tie bar Steering wheel	OIL 15 A94 (Wheel selection)	2 1 1

For a second station add:
1 UP25 or UP28 helm pump, 1 KIT OB-25 fitting kit, 1 KIT OB, 1 OIL 15, 1 steering wheel

Dual engine Dual cylinder 	Up to 500 hp max (non-counter rotating engines)	6,1 (UP39)	Cylinder Cylinder Port Helm pump Hose Kit	UC128-OBF UC128P-OBF UP39 or UP45 KIT OB	1 1 1 2
		5,3 (UP45)	Oil Tie bar Steering wheel Connection Kit	OIL 15 A90 (Wheel selection) KIT OB-DBR	3 1 1 1

For a second station add:
1 UP39 or UP45 helm pump, 1 KIT OB-25 fitting kit, 1 KIT OB, 2 T fittings 39502 V, 1 OIL 15, 1 steering wheel

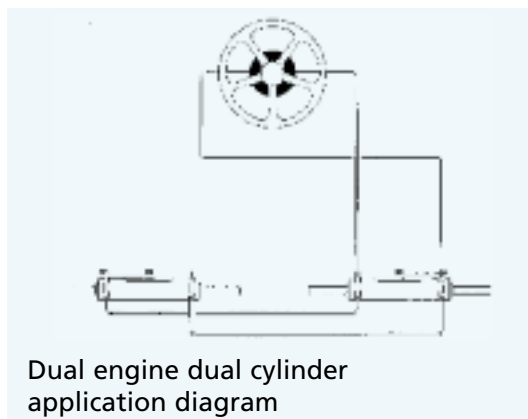

WARNING

These steering systems can only be used when the engine is in compliance with the approved U.S. Coast Guard vessel horsepower rating. When installing UC128-OBF cylinder in conjunction with an **ENGINE JACK PLATE** trim system, a manual clearance check must be made in all moveable positions. Failure to comply with the installation manual for engine application, cylinder/hose clearance, and approved hydraulic fluids, may result in loss of steering, causing serious property damage and / or personal injury.

NOTE:

Three outboard engine applications are available with UC128-OBF cylinder. For any further and detailed information, please contact our Technical Service.



For triple outboard engines, dual cylinder applications, please refer to tie-bar section.





UC132-OBS SIDE MOUNT CYLINDER

44

WARNING

The UC132-OBS is not intended for use with 1500 psi UP-SVS Series helms.



UC132-OBS

Unbalanced: the number of turns lock-to-lock is not equal port to starboard and vice-versa

SPECIFICATIONS	UC132-OBS - 39430 W
Volume	132 / 163 cc - 8 / 9.95 cu. in
Output force	464 / 574 kg - 1023 / 1265 lbs
Inside diameter	32 mm - 1.25"
Stroke	203 mm - 8"
3/8" (9,5 mm) fittings	For high pressure flex hose

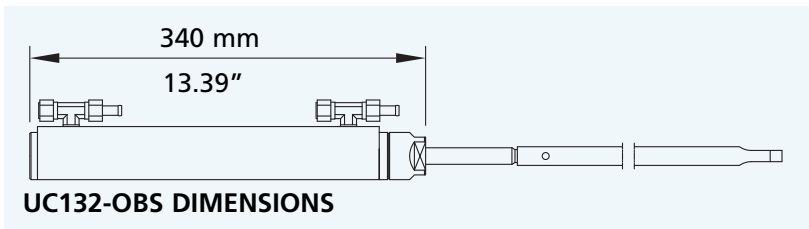

UC132-OBS DIMENSIONS

UC132-OBS side mount cylinder features a turning nut for fast and easy installation to the engine tube (PATENTED)

Clearance required at the engine tube side: 375 mm (14.76")

ORDER GUIDE:

SYSTEM	APPLICATION	WHEEL TURNS	COMPONENTS	MODEL	QTY	
Single engine Single cylinder 	Up to 300 hp max	5,3/6,5 (UP25)	Cylinder Helm pump Hose Kit	UC132-OBS UP25 or UP28	1 1	
		4,7/5,8 (UP28)	Oil Steering wheel	KIT OB OIL 15 (Wheel selection)	1 2 1	
		For a second station add:				
		1 UP25 or UP28 helm pump, 1 KIT OB-25 fitting kit, 1 KIT OB, 1 OIL 15, 1 steering wheel				

WARNING:

the UC132-OBS side mount cylinder is not recommended for use in installations where the boat speed exceeds **45 mph (45 knots)** and the power exceeds max Coast Guard recommendation for the boat.

Not intended for use in racing application.

Dual engine Single cylinder 	Up to 300 hp max (non-counter rotating engine) Up to 450 hp max (counter rotating engine)	5,3/6,5 (UP25)	Cylinder Helm pump Hose Kit Oil	UC132-OBS UP25 or UP28 KIT OB OIL 15	1 1 1 2	
		4,7/5,8 (UP28)	Tie bar Steering wheel	A92 (Wheel selection)	1 1	
		For a second station add:				
		1 UP25 or UP28 helm pump, 1 KIT OB-25 fitting kit, 1 KIT OB, 1 OIL 15, 1 steering wheel				

Dual engine Dual cylinder 	Up to 500 hp max (non-counter rotating engines) Up to 600 hp max (counter rotating engines)	6,7/8,3 (UP39)	Cylinder Helm pump Hose Kit Oil	UC132-OBS UP39 or UP45 KIT OB OIL 15	2 1 2 3	
		5,8/7,3 (UP45)	Tie bar Steering wheel	A92 (Wheel selection)	1 1	
		For a second station add:				
		1 UP39 or UP45 helm pump, 1 KIT OB-25 fitting kit, 1 KIT OB, 2 tee fittings 39502 V, 1 OIL 15, 1 steering wheel				

WARNING: THIS APPLICATION REQUIRES THAT THE THREADS ON THE TILT TUBE EXTEND AT LEAST 0.6" (15 mm) FROM BOTH SIDES.

HIGH PRESSURE FLEXIBLE HOSES

KIT OB : HOSE KIT FOR SINGLE STATION INSTALLATION

Two high pressure flexible hoses with pre-crimped brass fittings and bend restrictors on both ends. Recommended for use with all Ultraflex helms with 1000 psi relief valves.



KIT OB

KIT OB-BHBR: HOSE KIT FOR SINGLE STATION INSTALLATION

Two high pressure flexible hoses with pre-crimped brass fittings, bulkhead fittings and bend restrictors on both ends. Recommended for use with all Ultraflex helms with 1000 psi relief valves.



KIT OB-BHBR

KIT OB	KIT OB-BHBR	LENGTH
KIT OB-02	KIT OB-BHBR-02	2'
KIT OB-04	KIT OB-BHBR-04	4'
KIT OB-06	KIT OB-BHBR-06	6'
KIT OB-08	KIT OB-BHBR-08	8'
KIT OB-10	KIT OB-BHBR-10	10'
KIT OB-12	KIT OB-BHBR-12	12'
KIT OB-14	KIT OB-BHBR-14	14'
KIT OB-16	KIT OB-BHBR-16	16'
KIT OB-18	KIT OB-BHBR-18	18'
KIT OB-20	KIT OB-BHBR-20	20'
KIT OB-22	KIT OB-BHBR-22	22'
KIT OB-24	KIT OB-BHBR-24	24'
KIT OB-26	KIT OB-BHBR-26	26'
KIT OB-28	KIT OB-BHBR-28	28'
KIT OB-30	KIT OB-BHBR-30	30'

KIT OB-DBR : DUAL CYLINDER/ DUAL ENGINE CONNECTION KIT

Two high pressure flexible hoses, with pre-crimped fittings and bend restrictors on both ends. Not recommended for use with SilverSteer™ Series cylinders.

Three lengths available: 2', 3', 4'

KIT OB-DBR	LENGTH
KIT OB-DBR-02	2'
KIT OB-DBR-03	3'
KIT OB-DBR-04	4'



KIT OB-DBR

KIT OB-2S: FITTINGS FOR A SECOND STEERING STATION OR AUTOPILOT INSTALLATION

It includes all necessary fittings and 8 m (26.3 ft) of 3/8" dia. nylon tube for the compensating line

KIT OB-2S - 39539 V



KIT OB-2S

STANDARD OUTBOARD HYDRAULIC STEERING SYSTEMS PACKAGED IN A BOX

HYCO-OBF WHEEL TURNS 4,7

For outboard engines up to 150 hp

HYCO package kit contains:

UP20 F Front mount helm pump.
UC94-OBF Front mount outboard cylinder
Specify engine type when ordering.

HYCO-1 - with UC94-OBF/1 cylinder

OIL 15 Hydraulic oil - 2 quarts.
KIT OB OPTIONAL Hose kit with preassembled fittings
Specify length required when ordering

The wheel is not included.

WARNING: Depending on the applications, the UC94-OBF is available in 2 versions: UC94-OBF/1 and UC94-OBF/3. UC94-OBF/1 cylinder is not suitable for HONDA® BF115 and BF130 engines and Mercury® Optimax™ 75, 90, 115. For these engines UC94-OBF/3 is available.

Featuring the unique split tilt tube rod that allows for installation of the UC94 cylinder without removing the engine, the Hyco is an easy and affordable outboard hydraulic steering solution for boats with 150 horsepower and under. Coupled with the composite UP20 helm, the Hyco offers effortless steering with 5 turns lock to lock. And, it is applicable to almost all 2 and 4 stroke outboards engines.

PROTECH WHEEL TURNS 4,29

PROTECH package kit contains:

UP28 F Front mount helm pump.
UC128-OBF Front mount outboard cylinder.
Specify engine type when ordering.

PROTECH 1 - with UC128-OBF/1 cylinder

PROTECH 2 - with UC128-OBF/2 cylinder

PROTECH 3 - with UC128-OBF/3 cylinder

OIL 15 Hydraulic oil - 2 quarts .
KIT OB OPTIONAL Hose kit with preassembled fittings.
Specify length required when ordering

The wheel is not included.

Durability and performance define the Protech front mount outboard steering package. From the stainless steel helm shaft, heavy duty shaft seals, carbon steel piston and 304 electropolished and passivated stainless link assemblies, the Protech is built for maximum longevity and peak performance. Adjustable boss style fittings allow precise hose routing without the risk of breaking the fittings by overtightening or leaking fittings from loosening during installation, a common problem on competing cylinders.



HYCO-1



PROTECH

SilverSteer™ SVS helms have been specifically designed for high torque applications such as bass boats, flats boats, and boats with shallow dead rise and high horsepower.

Featuring a 1500 psi check valve and a patented pressure valve that enhances responsiveness, the SilverSteer™ helms will deliver very precise steering at all torque loads.

The SVS helms are always to be installed in conjunction with the UC128-SVS cylinders and the Kit OB-SVS hoses, which are also specifically designed for high torque applications.

The front mount version is a direct drop-in replacement for competing helms. Both the front mount and tilt helms feature stainless steel shafts and adjustable 45° boss style fittings.



FEATURES

- Available in three different displacement sizes
- Compact design
- Ball bearing piston race
- Built-in lock valve for positive rudder lock
- **Integral relief valve for over-pressure protection 105 bar (1500 psi)**
- 3/4" tapered stainless steel shaft
- Easily accessible lock valve and shaft seal for replacement
- Cast iron rotor for greater durability and longer life
- **Complete with fittings adjustable at 45° for 3/8" tube**

MOD.	P. No.	MOUNTING	DISPLACEMENT/ REVOLUTION	No. OF PISTONS	RELIEF VALVE SETTING	MAXIMUM WHEEL DIA.	WEIGHT
UP28 F-SVS	41280 S	Front mount	28 cc - 1.7 cu.in	5	105 bar - 1500 PSI	710 mm - 28"	5 kg - 11 lbs
UP33 F-SVS	41327 S	Front mount	33 cc - 2.0 cu.in	7	105 bar - 1500 PSI	710 mm - 28"	5 kg - 11 lbs
UP39 F-SVS	41876 C	Front mount	39 cc - 2.4 cu.in	7	105 bar - 1500 PSI	710 mm - 28"	5 kg - 11 lbs

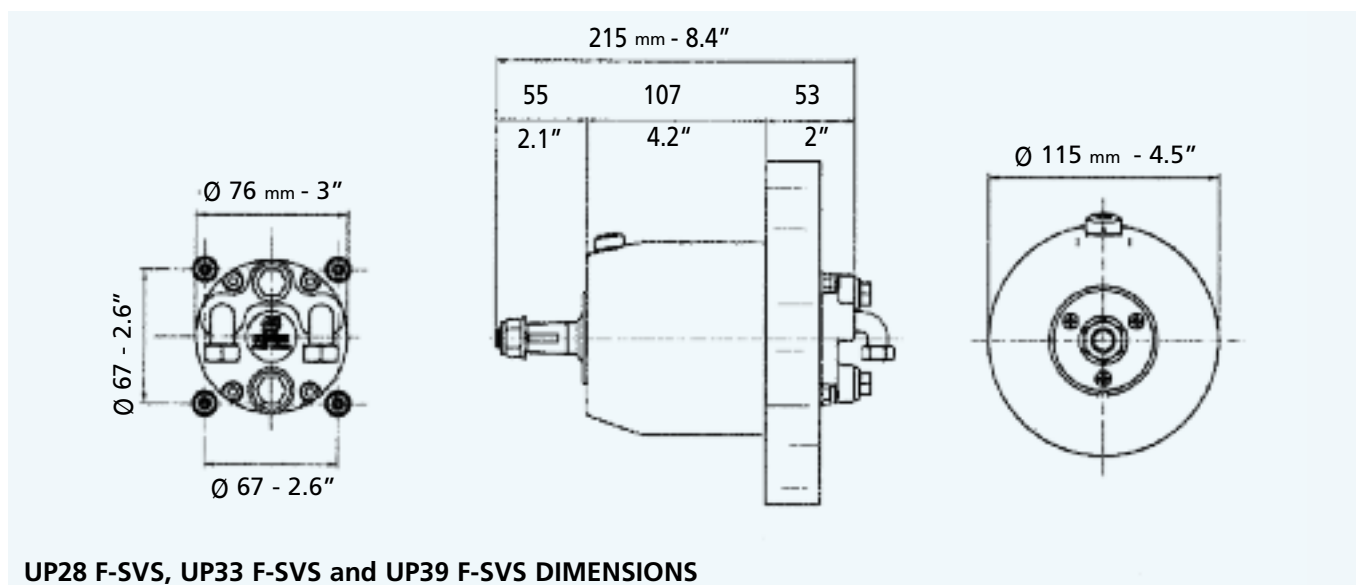

UP28 F-SVS, UP33 F-SVS and UP39 F-SVS DIMENSIONS



FEATURES

- Available in three different displacement sizes
- Compact design
- Ball bearing piston race
- Built-in lock valve for positive rudder lock (patented)
- **Integral relief valve for over-pressure protection 105 bar (1500 psi)**
- Stainless steel shaft
- Easily accessible lock valve and shaft seal for replacement
- Cast iron rotor for greater durability and longer life
- Complete with fittings adjustable at 45° for 3/8" tube
- Tilt mechanism for SilverSteer™ systems:
X70-SVS – 41880 T
- Tilt range of 48° and five locking positions

WARNING: X52 standard tilt mechanism cannot be used on SilverSteer™ high performance helm pumps
KIT-F (optional) – 39664 Y Remote fill adapter



MODEL	P. No.	MOUNTING	DISPLACEMENT/ REVOLUTION	No. OF PISTONS	RELIEF VALVE SETTING	MAXIMUM WHEEL DIA.	WEIGHT
UP28 T-SVS	41814 D	With X70-SVS	28 cc - 1.7 cu.in	5	105 Bar - 1500 PSI	406 mm - 16"	5 kg - 11 lbs
UP33 T-SVS	41815 F	With X70-SVS	33 cc - 2.0 cu.in	7	105 Bar - 1500 PSI	406 mm - 16"	5 kg - 11 lbs
UP39 T-SVS	41881 V	With X70-SVS	39 cc - 2.4 cu.in	7	105 Bar - 1500 PSI	406 mm - 16"	5 kg - 11 lbs

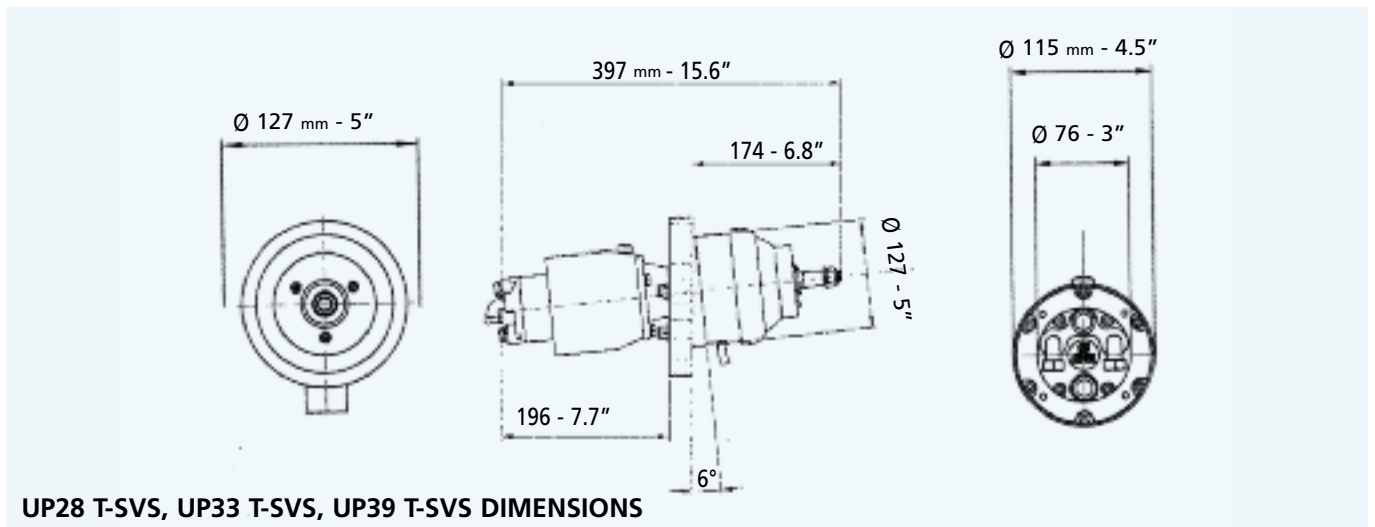



UC128-SVS – Balanced: the number of turns lock-to-lock is equal port to starboard or vice-versa

Adjustable boss style fittings for easy and leak free installation

High resistance stainless steel connection bolt (ULTRABOLT)

Specially designed for high performance, high torque applications the SilverSteer™ UC128 SVS cylinder is recommended for bass boats, flat boats and tournament fishing boats. Compatible with competing helms, hoses and oil, the UC128-SVS is built to last with heavy duty stainless steel cylinder rod, seals and link assemblies. Constructed of top grade materials this cylinder is simple to install and fits almost every 2 and 4 stroke outboard engine in the market. See the application guide next page to choose the appropriate cylinder (UC128-SVS/1, UC128-SVS/2 or UC128-SVS/3) for your application.

Depending on the applications on the outboard engines, the UC128-SVS is available in 3 versions:

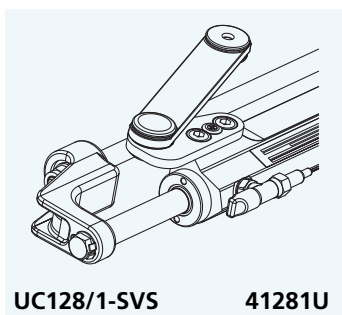

UC128/1-SVS 41281U

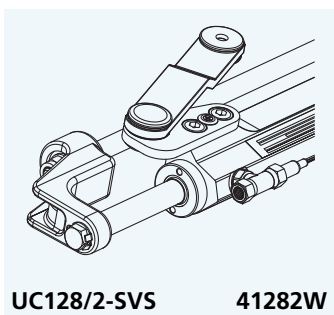

UC128/2-SVS 41282W

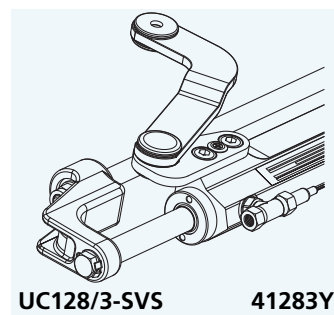

UC128/3-SVS 41283Y

In the applications with dual UC128-SVS cylinder it is necessary to order a standard UC128-SVS cylinder (link arm attached to the starboard side of the cylinder) and a port UC128-SVS cylinder (link arm attached to the port side of the cylinder). See appropriate section for A90 tie bar required for use on dual engine/dual cylinder applications.

Depending on the applications on the outboard engines, the UC128P-SVS port cylinder is available in 2 versions:



UC128P-SVS

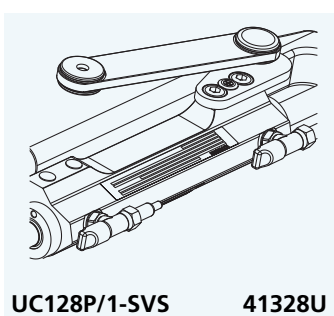

UC128P/1-SVS 41328U

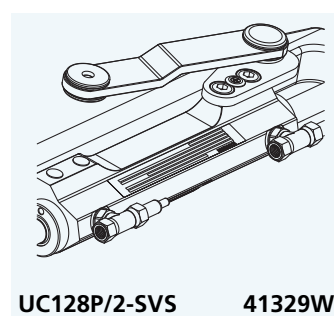

UC128P/2-SVS 41329W

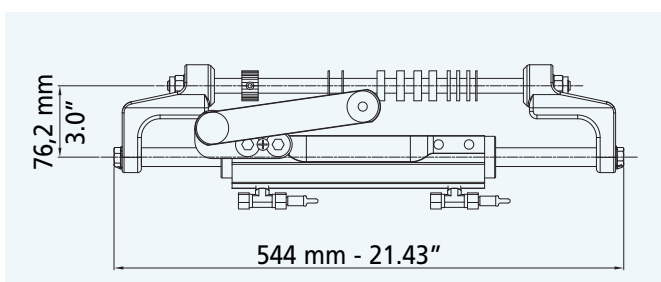

UC128-SVS, UC128P-SVS DIMENSIONS

SPECIFICATIONS	UC128/1 -/2 -/3 SVS
Volume	120 cc - 7.3 cu. in
Output force	450 kg - 992 lbs
Inside diameter	35 mm - 1.37"
Stroke	185 mm - 7.28"
3/8" (9.5mm) Fittings	For high pressure flex hose
Bleed fittings	DN5 Quick connect



SILVERSTEER™

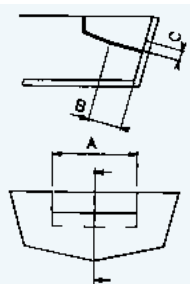

SPLASHWELL DIMENSION REQUIREMENTS

Engine No.	A	B	C
1	560 mm - 22.05"	152 mm - 5.98"	152 mm - 5.98"
2	1110 mm - 43.70"	152 mm - 5.98"	152 mm - 5.98"

For twin engine applications minimum engine center distance is 21.6" (550 mm)

50

**UC128-SVS
CYLINDER
APPLICATIONS**

ENGINE	POWER	YEAR	CYLINDER	P. No.	PACKAGED
Mercury® Mariner®	115-125-150 EFI 2 Stroke	1990-2007	UC128/1-SVS	41281 U	Silversteer 1
	225-250 EFI 2 Stroke	2000-2007	UC128/1-SVS	41281 U	Silversteer 1
	135-150-175 Optimax	1999-to date	UC128/1-SVS	41281 U	Silversteer 1
	200-225-250 Optimax	1999-to date	UC128/1-SVS	41281 U	Silversteer 1
	RACING 300 Optimax		UC128/1-SVS	41281 U	Silversteer 1
	250 Saltwater EFI 4 Stroke	2004-2006	UC128/1-SVS	41281 U	Silversteer 1
	135-150-175-200 Verado L4		UC128/1-SVS	41281 U	Silversteer 1
Evinrude®	E115-E130-E135 2 Stroke V4	1995-to date	UC128/2-SVS	41282 W	Silversteer 2
	E150-E175-E200 2 Stroke V6	1995-to date	UC128/2-SVS	41282 W	Silversteer 2
	E200 HO- E225-E250 2 Stroke V6	1995-to date	UC128/2-SVS	41282 W	Silversteer 2
	E250HO- E300 2 Stroke V6		UC128/2-SVS	41282 W	Silversteer 2
Yamaha®	115C-130B 2 Stroke	1998-2008	UC128/2-SVS	41282 W	Silversteer 2
	150F-200F-250G 2 Stroke	1996-2007	UC128/2-SVS	41282 W	Silversteer 2
	150 HPDI VMAX 2 Stroke	2000-2008	UC128/2-SVS	41282 W	Silversteer 2
	175-200-225-250-300 HPDI VMAX 2 St.	2000-2008	UC128/2-SVS	41282 W	Silversteer 2
	F115-F150 EFI 4 Stroke	1999-2007	UC128/1-SVS	41281 U	Silversteer 1
	F200-F225-F250 4 Stroke	2002-2007	UC128/2-SVS	41282 W	Silversteer 2
	F115-F150	2004-to date	UC128/1-SVS	41281 U	Silversteer 1
F200-F225-F250-F300-F350 4 Stroke	2006-to date	UC128/2-SVS	41282 W	Silversteer 2	
Honda®	BF135-150 4 Stroke	2005-to date	UC128/1-SVS	41281 U	Silversteer 1
	BF150 V-TEC 4 Stroke	2008-to date	UC128/1-SVS	41281 U	Silversteer 1
	BF175-BF200-BF225 4 Stroke	2001-to date	UC128/1-SVS	41281 U	Silversteer 1
Suzuki®	DF100-115-140 4 Stroke*	1998-2008	UC128/1-SVS*	41281 U	Silversteer 1
	DF100-115-140 4 Stroke	2008-to date	UC128/1-SVS	41281 U	Silversteer 1
	DF150-175 4 Stroke	2006-to date	UC128/1-SVS	41281 U	Silversteer 1
	DF200-DF225-DF250-DF300		UC128/2-SVS	41282 W	Silversteer 2
Tohatsu®	115-120-140 2 Stroke	2004-to date	UC128/2-SVS	41282 W	Silversteer 2
	70-90-115 TLDI 4 Stroke	2004-to date	UC128/1-SVS	41281 U	Silversteer 1
Selva®	80 Portofino/Tigershark 2 Stroke	1995-2008	UC128/2-SVS	41281 U	Silversteer 2
	150 White Shark 2 Stroke	2001-2007	UC128/1-SVS	41282 W	Silversteer 1
	100EFI Marlin -115 EFI Narwhal- 150EFI Killer Whale 4 Stroke	2000-to date	UC128/2-SVS	41281 U	Silversteer 2
Johnson®	BJ90-115-140 4 Stroke	2001-2007	UC128/1-SVS	41281 U	Silversteer 1
	J90-115 V4 2 Stroke	1995-2007	UC128/2-SVS	41282 W	Silversteer 2
	J150-175 V6 2 Stroke	1995-2007	UC128/2-SVS	41282 W	Silversteer 2
	J200-225 V6 4 Stroke	2004-2007	UC128/2-SVS	41282 W	Silversteer 2

***NOTE:**

Suzuki® engines built from 1998 to 2008 installing UC128/1-SVS cylinder require optional **KIT SU - 41954W**.

WARNING

These recommendations should be used as a general reference only. Final selection should be made with the assistance of a qualified installation technician. For any further information please contact our Technical Service.

SILVERSTEER™
UC128-SVS
CYLINDER

SYSTEM	APPLICATION	WHEEL TURNS	COMPONENTS	MODEL	QTY
Single Engine Single Cylinder 	Up to 350 hp max	4,3 (UP28)	Cylinder	UC128-SVS	1
			Helm pump	UP28 or UP33-SVS	1
		Hose Kit	KIT OB-SVS	1	
		Oil	OIL 15	2	
		Steering wheel	(Wheel selection)	1	

For a second station add:
 1 UP28-SVS or UP33-SVS helm pump, 1 KIT OB-2S fitting kit, 1 KIT OB-SVS, 1 OIL 15, 1 steering wheel

Dual engine Single cylinder 	Up to 350 hp max (non-counter rotating engine) Up to 600 hp max (counter rotating engine)	4,3 (UP28)	Cylinder	UC128-SVS	1
			Helm pump	UP28 or UP33-SVS	1
		Hose Kit	KIT OB-SVS	1	
		Oil	OIL 15	2	
		Tie bar	A94	1	
Steering wheel	(Wheel selection)	1			

For a second station add:
 1 UP28-SVS or UP33-SVS helm pump, 1 KIT OB-2S fitting kit, 1 KIT OB-SVS, 1 OIL 15, 1 steering wheel

Dual engine Dual cylinder 	Up to 600 hp max (non-counter rotating engines)	6,1 (UP39)	Cylinder	UC128-SVS	1
			Cylinder Port	UC128P-SVS	1
			Helm pump	UP39-SVS	1
	Up to 700 hp max (counter rotating engines)		Hose Kit	KIT OB-SVS	2
			Oil	OIL 15	3
			Tie bar	A90	1
			Steering wheel	(Wheel selection)	1
Connection Kit	KIT OB-DBR-SVS	1			

For a second station add:
 1 UP39-SVS helm pump, 1 KIT OB-2S fitting kit, 1 KIT OB-SVS, 2 T fittings 39502 V, 1 OIL 15, 1 steering wheel

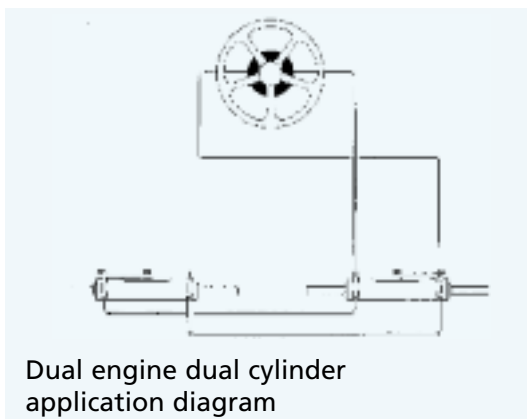

ATTENTION:

The SilverSteer™ helm pumps are always to be installed in conjunction with the UC128-SVS cylinder and the Kevlar reinforced hose kit KIT OB-SVS.

NOTE:

Three outboard engine applications are available with UC128-SVS cylinder. For any further and detailed information, please contact our Technical Service.



For triple outboard engines, dual cylinder applications, please refer to tie-bar section.





HIGH PERFORMANCE OUTBOARD STEERING SYSTEMS

KIT OB-SVS : HOSE KIT FOR SINGLE STATION INSTALLATION FOR SILVERSTEER™ SYSTEMS

Two high pressure flexible hoses with pre-crimped nickel plated brass fittings and bend restrictors on both ends. Recommended for use with all Ultraflex SVS helms with 1500 psi relief valves.



KIT OB-SVS

KIT OB-BHBR-SVS : HOSE KIT FOR SINGLE STATION INSTALLATION FOR SILVERSTEER™ SYSTEMS

Two high pressure flexible hoses with pre-crimped nickel plated brass fittings, bulkhead fittings and bend restrictors on both ends. Recommended for use with all Ultraflex SVS helms with 1500 psi relief valves.



KIT OB-BHBR-SVS

KIT OB-SVS	KIT OB-BHBR-SVS	LENGTH
KIT OB-SVS-02	KIT OB-BHBR-SVS-02	2'
KIT OB-SVS-04	KIT OB-BHBR-SVS-04	4'
KIT OB-SVS-06	KIT OB-BHBR-SVS-06	6'
KIT OB-SVS-08	KIT OB-BHBR-SVS-08	8'
KIT OB-SVS-10	KIT OB-BHBR-SVS-10	10'
KIT OB-SVS-12	KIT OB-BHBR-SVS-12	12'
KIT OB-SVS-14	KIT OB-BHBR-SVS-14	14'
KIT OB-SVS-16	KIT OB-BHBR-SVS-16	16'
KIT OB-SVS-18	KIT OB-BHBR-SVS-18	18'
KIT OB-SVS-20	KIT OB-BHBR-SVS-20	20'
KIT OB-SVS-22	KIT OB-BHBR-SVS-22	22'
KIT OB-SVS-24	KIT OB-BHBR-SVS-24	24'
KIT OB-SVS-26	KIT OB-BHBR-SVS-26	26'
KIT OB-SVS-28	KIT OB-BHBR-SVS-28	28'
KIT OB-SVS-30	KIT OB-BHBR-SVS-30	30'

KIT OB-DBR-SVS : DUAL CYLINDER/ DUAL ENGINE CONNECTION KIT FOR SILVERSTEER™ SYSTEMS

Two high pressure flexible hoses, with pre-crimped fittings and bend restrictors on both ends. Recommended for use with all Ultraflex SVS helms with 1500 psi relief valves. Three lengths available: 2', 3', 4'.

KIT OB-DBR-SVS	LENGTH
KIT OB-DBR-SVS-02	2'
KIT OB-DBR-SVS-03	3'
KIT OB-DBR-SVS-04	4'



KIT OB-DBR-SVS



HIGH PERFORMANCE OUTBOARD STEERING SYSTEM

PACKAGED IN A BOX

Specifically designed for high performance and high torque applications, the SilverSteer features a 1500 psi helm and keyed bullhorns on the cylinder for maximum durability and minimal lost motion.

Whether a bass boat, flat boat or tournament style offshore fishing boat, the SilverSteer™ will deliver smooth, responsive and precise steering.

Adjustable boss style fittings allow precise hose routing without the risk of breaking the fittings by overtightening or leaking fittings from loosening during installation, a common problem on competing cylinders

SILVERSTEER™ WHEEL TURNS: 4,3

SilverSteer™ package kit contains:

- UP28 F-SVS** Front mount helm pump
- UC128-SVS** Front mount outboard cylinder.
Specify engine type when ordering.

- Silversteer 1** - with UC128/1-SVS cylinder
- Silversteer 2** - with UC128/2-SVS cylinder

- OIL 15** Hydraulic oil 2 litres (0.5 gallons).
- KIT OB-SVS** Hose kit with preassembled fittings.
Specify length required when ordering.

The wheel is not included.

CE 53





POWER ASSISTED OUTBOARD STEERING SYSTEM

Effortless steering for the most demanding applications!

For the ultimate in steering performance, look no further than the MasterDrive™ power assisted outboard steering system which delivers fingertip control regardless of speed or torque conditions.

With installation similar to conventional manual hydraulic system, the MasterDrive™ eliminates torque at the steering wheel, yet the system maintains functional manual hydraulic steering override in the event of a loss of power.

54



MD



MasterDrive™ SYSTEM FEATURES

- Three different selectable levels of power give the boater the desired feeling on the wheel (PATENTED).
- Automatically reverts to manual mode in case of power loss.
- High efficiency, low Amp draw
- Immediate control in any sea conditions through the system always running.
- Equipped with safety switch ON/OFF (SMART BUTTON)
- Can be used on dual station installations
- Suitable for use with autopilot
- Low noise
- Voltage: 12VDC
- CE marked in conformity with ABYC P21, ISO 10592 safety standards
- Ignition protected (SAE J-1171 and UNI EN 28846)

SYSTEM COMPONENTS:

- 1 Front or Tilt Mount Helm UH
- 1 Power Unit UPMD, 15' wiring harness included
- 1 SilverSteer™ Steering Cylinder UC128-SVS (1 UC128-SVS starboard+1 UC128/P-SVS port on dual cylinder applications)
- 1 User Interface UCMD
- 1 KIT OBMD: high pressure antidumping hose kit complete with preassembled fittings.
- 1 KIT OB-SVS: SilverSteer™ high pressure hose kit complete with preassembled fittings.
- 1 KIT OB-DBR-SVS: SilverSteer™ high pressure hose kit complete with preassembled fittings for cylinder connection (dual cylinder applications only).
- Hydraulic oil OIL 15

OPTIONAL COMPONENTS:

- 1 Tilt mechanism X66-40613 M suitable for Tilt Mount Helm. Tilt range of 48° and five locking positions.
- 1 Dual cylinder application Tie Bar: see selection
- 1 Steering Wheel: see selection

SINGLE CYLINDER APPLICATION

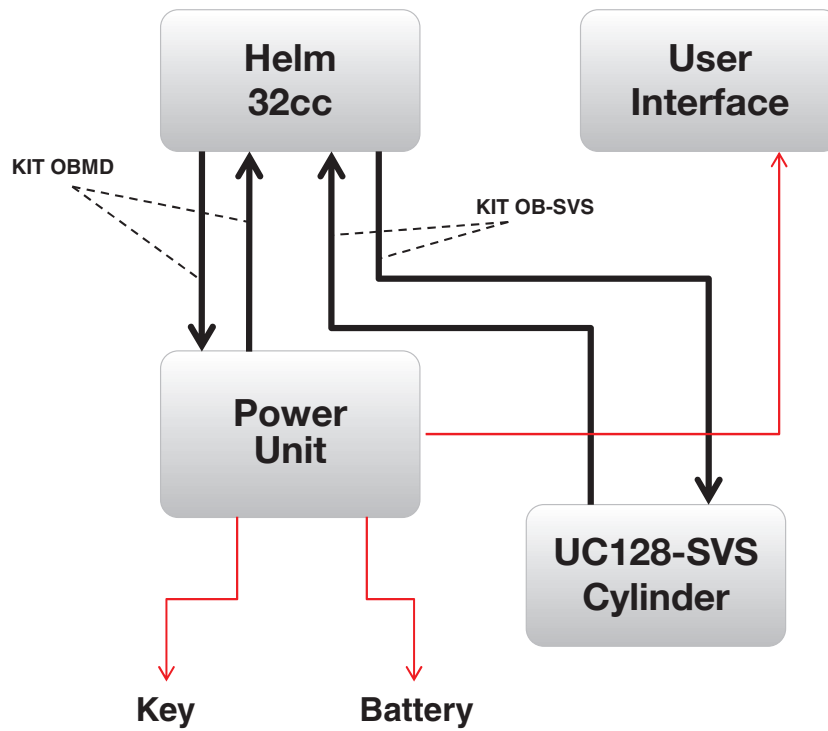

— wiring harness

— high pressure hoses

DUAL CYLINDER APPLICATION

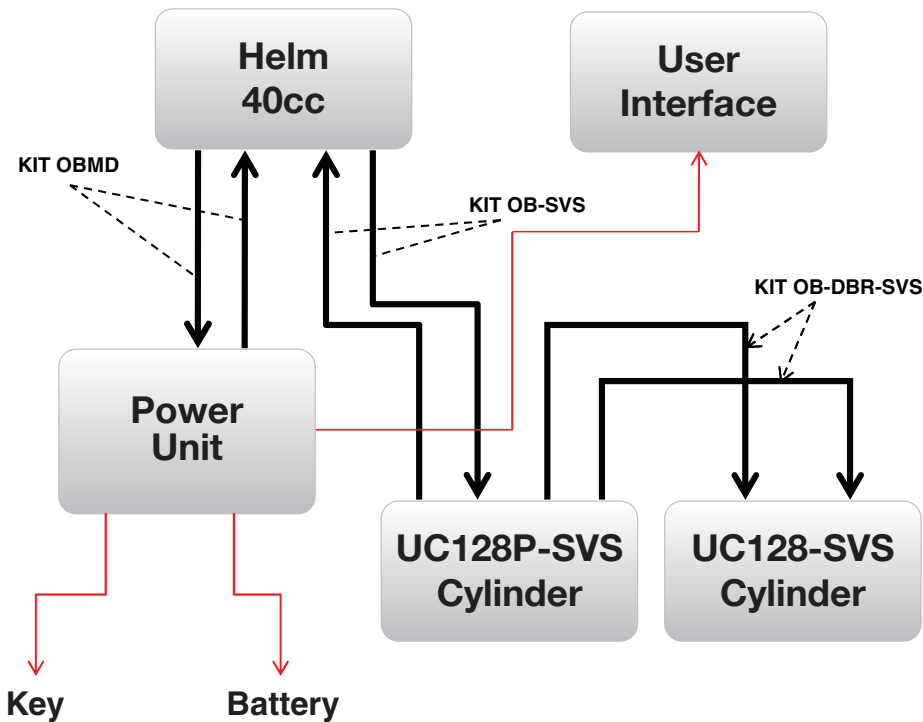

— wiring harness

— high pressure hoses



POWER ASSISTED OUTBOARD STEERING SYSTEM

HELM FEATURES - UH

- Available in two different displacement sizes: 32 cc (1.95 cu.in) and 40 cc (2.44 cu.in)
- Front Mount and Tilt Mount versions
- Dual station installation version (front mount, 40cc displacement only)
- Built-in relief valve
- 3/4" tapered shaft
- Corrosion resistant painted body
- Waterproof
- Tilt Mount version is suitable for use with X66-40613 M tilt mechanism



56

MODEL	P. No.	MOUNTING	DISPLACEMENT/ REVOLUTION	APPLICATION	No. OF STATIONS	MAXIMUM WHEEL DIA.
UH32-F	42091 U	front mount	32cc - 1.95 cu.in	single cylinder	1	406 mm - 16"
UH32-T	42092 W	with X66 tilt	32cc - 1.95 cu.in	single cylinder	1	406 mm - 16"
UH40-F	42093 Y	front mount	40cc - 2.44 cu.in	dual cylinder	1	406 mm - 16"
UHD40-F	42094 A	front mount	40cc - 2.44 cu.in	dual cylinder	2	406 mm - 16"
UH40-T	42095 C	with X66 tilt	40cc - 2.44 cu.in	dual cylinder	1	406 mm - 16"

UH32: wheel turns lock-to-lock in single cylinder applications: **3,75**

UH40: wheel turns lock-to-lock in dual cylinder applications: **6**

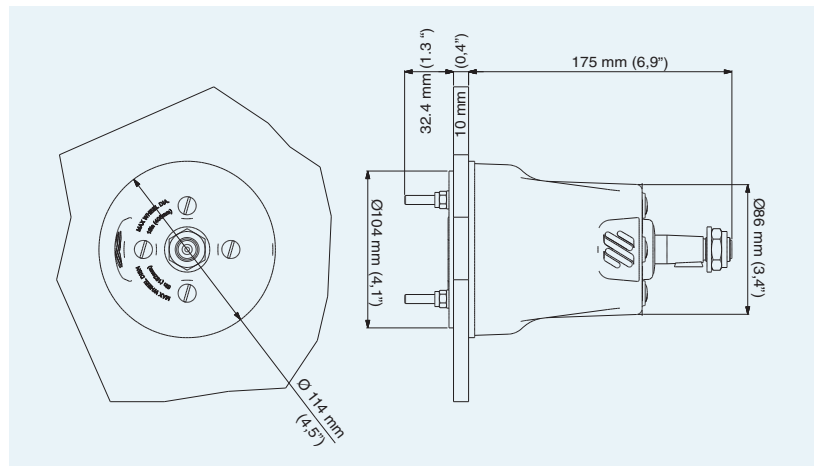

UH32-F, UH32-T, UH40-F, UHD40-F and UH40T DIMENSIONS

USER INTERFACE FEATURES - UCMD 42097 G

- Safety switch ON/OFF(SMART BUTTON)
- Three different power levels with light indicator (PATENTED)
- Motor temperature visual indicator
- Twin engine key selection included
- Lighted panel for stand-by position
- Plug-in wiring harness
- Suitable for a second station installation



POWER ASSISTED OUTBOARD STEERING SYSTEM

POWER UNIT FEATURES - UPMD 42096 E

- 12VDC Motor
- 45° swiveling fittings for easy installation
- Semitransparent 0,5 litre (0.11gal) tank gives immediate level vision
- Vented filler plug
- Wall or floor mount
- Black galvanized motor case, salt water resistant
- 4,5 m (15') Wiring Harness included
- IP67 waterproof
- Ignition protected (SAE J-1171 and UNI EN 28846)

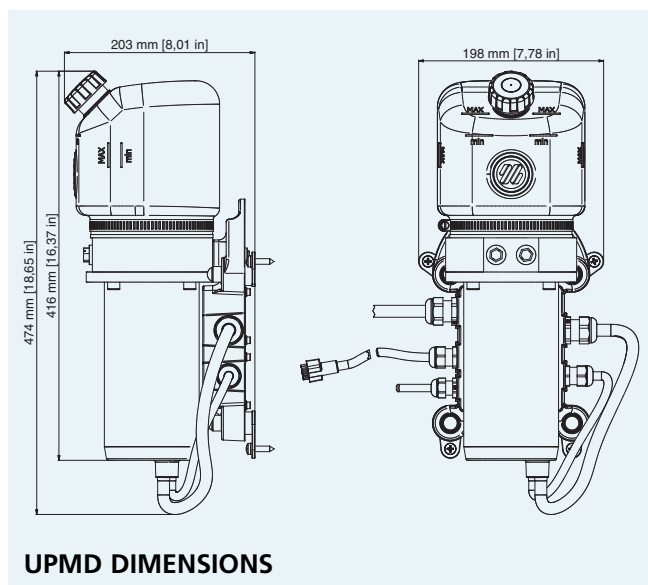

HOSE KITS

KIT OB-SVS	LENGTH	PART No.
KIT OB-SVS-10	1,00 m - 3.3 ft	41334 N
KIT OB-SVS-15	1,50 m - 4.9 ft	41800 S
KIT OB-SVS-20	2,00 m - 6.6 ft	41339 Z
KIT OB-SVS-25	2,50 m - 8.2 ft	42106 E
KIT OB-SVS-30	3,00 m - 9.8 ft	41286 E
KIT OB-SVS-35	3,50 m - 11.5 ft	41287 G
KIT OB-SVS-40	4,00 m - 13.1 ft	41288 J
KIT OB-SVS-45	4,50 m - 14.8 ft	41289 L
KIT OB-SVS-50	5,00 m - 16,4 ft	41290 V
KIT OB-SVS-55	5,50 m - 18.0 ft	41291 X
KIT OB-SVS-60	6,00 m - 19.7 ft	41292 Z

KIT OBMD	LENGTH	PART No.
KIT OBMD-10	1,00 m - 3.3 ft	42107 G
KIT OBMD-15	1,50 m - 4.9 ft	42108 J
KIT OBMD-20	2,00 m - 6.6 ft	42109 L
KIT OBMD-25	2,50 m - 8.2 ft	42110 V
KIT OBMD-30	3,00 m - 9.8 ft	42111 X
KIT OBMD-35	3,50 m - 11.5 ft	42112 Z
KIT OBMD-40	4,00 m - 13.1 ft	42113 B
KIT OBMD-45	4,50 m - 14.8 ft	42114 D
KIT OBMD-50	5,00 m - 16,4 ft	42115 F
KIT OBMD-55	5,50 m - 18.0 ft	42116 H
KIT OBMD-60	6,00 m - 19.7 ft	42117K

KIT OB-DBR-SVS	LENGTH
KIT OB-DBR-SVS-02	2'
KIT OB-DBR-SVS-03	3'
KIT OB-DBR-SVS-04	4'



MASTERDRIVE - POWER ASSISTED OUTBORD STEERING SYSTEM

58

ORDER GUIDE

Tilt mechanism X66-40613 M, A90-40138 H tie bar in dual cylinder applications and steering wheel are optional.

MODEL	COMPONENTS	PART No.	Q.TY
MD32-1F	UH32-F Front Mount Helm	42091 U	1
	UPMD Power Unit w/harness	42096 E	1
	UC128/1-SVS Cylinder	41281 U	1
	UCMD User Interface	42097 G	1
	OIL15 Hydraulic Oil	70704 K	4
	KIT OB-SVS	Specify length	1
	KIT OBMD	Specify length	1
MD32-2F	UH32-F Front Mount Helm	42091 U	1
	UPMD Power Unit w/harness	42096 E	1
	UC128/2-SVS Cylinder	41282 W	1
	UCMD User Interface	42097 G	1
	OIL15 Hydraulic Oil	70704 K	4
	KIT OB-SVS	Specify length	1
	KIT OBMD	Specify length	1
MD32-1T	UH32-T Tilt Mount Helm	42092 W	1
	UPMD Power Unit w/harness	42096 E	1
	UC128/1-SVS Cylinder	41281 U	1
	UCMD User Interface	42097 G	1
	OIL15 Hydraulic Oil	70704 K	4
	KIT OB-SVS	Specify length	1
	KIT OBMD	Specify length	1
MD32-2T	UH32-T Tilt Mount Helm	42092 W	1
	UPMD Power Unit w/harness	42096 E	1
	UC128/2-SVS Cylinder	41282 W	1
	UCMD User Interface	42097 G	1
	OIL15 Hydraulic Oil	70704 K	4
	KIT OB-SVS	Specify length	1
	KIT OBMD	Specify length	1
MD40-D1F	UH40-F Front Mount Helm	42093 Y	1
	UPMD Power Unit w/harness	42096 E	1
	UC128/1-SVS Starboard Cylinder	41281 U	1
	UC128P/1-SVS Port Cylinder	41328 U	1
	UCMD User Interface	42097 G	1
	OIL15 Hydraulic Oil	70704 K	4
	KIT OB-SVS	Specify length	1
	KIT OBMD	Specify length	1
KIT OB-DBR-SVS	Specify length	1	
MD40-D2F	UH40-F Front Mount Helm	42093 Y	1
	UPMD Power Unit w/harness	42096 E	1
	UC128/2-SVS Starboard Cylinder	41282 W	1
	UC128P/2-SVS Port Cylinder	41329 W	1
	UCMD User Interface	42097 G	1
	OIL15 Hydraulic Oil	70704 K	4
	KIT OB-SVS	Specify length	1
	KIT OBMD	Specify length	1
KIT OB-DBR-SVS	Specify length	1	
MD40-D1T	UH40-T Tilt Mount Helm	42095 C	1
	UPMD Power Unit w/harness	42096 E	1
	UC128/1-SVS Starboard Cylinder	41281 U	1
	UC128P/1-SVS Port Cylinder	41328 U	1
	UCMD User Interface	42097 G	1
	OIL15 Hydraulic Oil	70704 K	4
	KIT OB-SVS	Specify length	1
	KIT OBMD	Specify length	1
KIT OB-DBR-SVS	Specify length	1	
MD40-D2T	UH40-T Tilt Mount Helm	42095 C	1
	UPMD Power Unit w/harness	42096 E	1
	UC128/2-SVS Starboard Cylinder	41282 W	1
	UC128P/2-SVS Port Cylinder	41329 W	1
	UCMD User Interface	42097 G	1
	OIL15 Hydraulic Oil	70704 K	4
	KIT OB-SVS	Specify length	1
	KIT OBMD	Specify length	1
KIT OB-DBR-SVS	Specify length	1	

NOTE: Upon request, UPMD Power Unit is available with custom length wiring harness

A94

TWIN OUTBOARD ENGINE/SINGLE

UC128-OBF or UC128-SVS CYLINDER TIE BAR

Heavy duty twin engine/single cylinder tie bar kit for use with UC128 outboard cylinders. Suitable for use with Protech cylinders, these AISI 304 electropolished and passivated stainless steel tie bars are simple to install and allow for independent trimming of engines with minimal effect on engine alignment. Not recommended for applications exceeding 500 HP.



59

A94 - 41204Z

- Suitable for applications with single UC128-OBF (or UC128-SVS) front mount cylinder
- NOTE: In the applications with dual cylinder use **A90** tie bar
- Allows to tilt the engines independently
- Electropolished/passivated stainless steel components and ball joints
- Adjustable from 660 mm (26") to 950 mm (37.4") engine centers

ATTENTION: As the tiller arm position varies from engine to engine and the distance between two engines is not predictable, unexpected interferences may occur while tilting. A duly check of the tie bar installation is then strongly recommended. Should you need additional information, please do not hesitate to refer to our Technical Service.

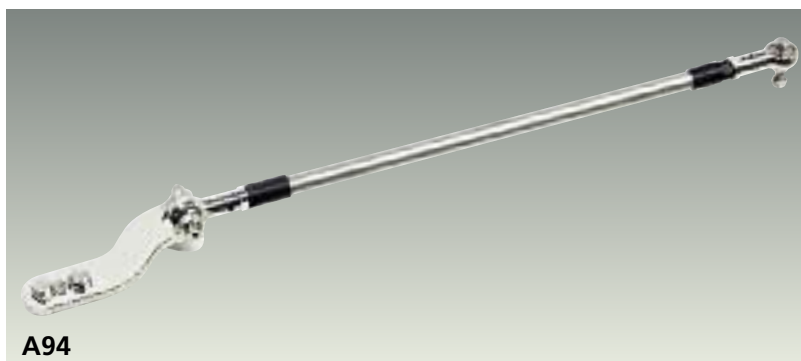

A94

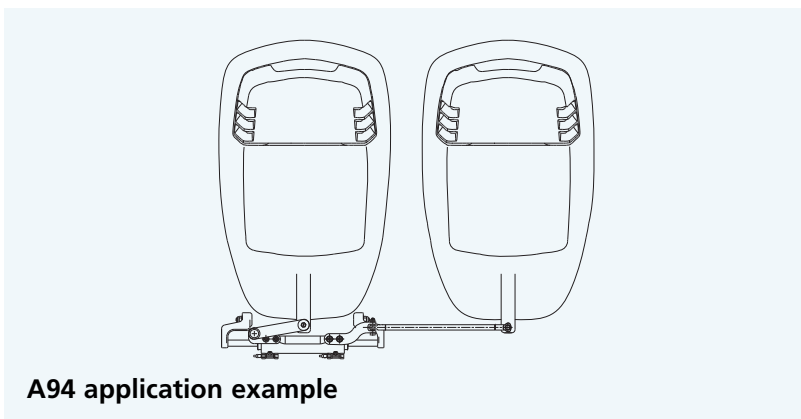

A94 application example

A94 TIE BAR APPLICATIONS

WARNING

These recommendations should be used as a general reference only. For any further information please contact our Technical Service.

ENGINE	POWER
Mercury®	135-150-175 Optimax 2 Stroke 200-225 Optimax 2 Stroke 250 PRO XS 135-150-175 Verado 4 Stroke 200 Verado 4 Stroke
Honda®	115-135-150 OHC BF 200 SOHC BF 225 A6
Yamaha®	F115-150-200-225-250 4 Stroke
Evinrude®	E115-130-150-175-200 V6 E200-225-250-300
Suzuki®	DF70-80-90 4 Stroke DF100-115-140-150-175 4 Stroke DF200-250-300 DOHC 4 Stroke



UC128 + A94



A90

TWIN OUTBOARD ENGINE/TWIN

UC128-OBF or UC128-SVS CYLINDER TIE BAR

Heavy duty twin engine/twin cylinder tie bar kit for use with UC128 and UC128P "Port" version outboard cylinders. Suitable for use with Protech and SilverSteer™ cylinders these AISI 304 electropolished and passivated stainless steel tie bars are simple to install and allow for independent trimming of engines with minimal effect on engine alignment.

60

A90 - X LL

- Suitable for applications with dual UC128-OBF (or UC128-SVS) front mount cylinder
- NOTE: in applications with single cylinder use A94 tie bar
- Allows to tilt the engines independently
- Electropolished/passivated stainless steel components and ball joints
- Applicable to engine centers variable from 26" (660 mm) to 37.4" (950 mm).

WARNING: In the applications with dual UC128-OBF (or UC128-SVS) cylinder it is necessary to order a standard UC128-OBF (or UC128-SVS) cylinder (link arm attached to the starboard side of the cylinder) and a UC128P-OBF (or UC128P-SVS) port cylinder (link arm attached to the port side of the cylinder).

UC128 starboard cylinders:

- UC128-OBF/1 - 39423 Z
- UC128-OBF/2 - 39966 R
- UC128-OBF/3 - 39967 T
- UC128/1-SVS - 41281 U
- UC128/2-SVS - 41282 W
- UC128/3-SVS - 41283 Y

UC128P port cylinders:

- UC128P-OBF/1 - 40106 U
- UC128P-OBF/2 - 40107 W
- UC128P/1-SVS - 41328 U
- UC128P/2-SVS - 41329 W

ATTENTION: As the tiller arm position varies from engine to engine and the distance between two engines is not predictable, unexpected interferences may occur while tilting. A duly check of the tie bar installation is then strongly recommended. Should you need additional information, please do not hesitate to refer to our Technical Service.



A90

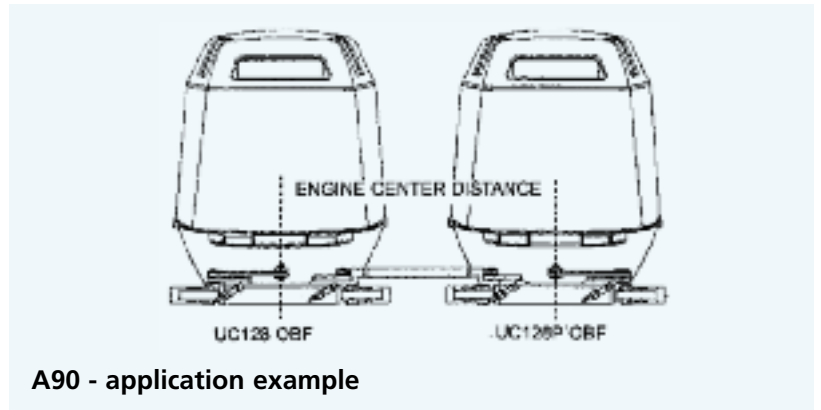

A90 - application example



UC128 + A90

A93

TRIPLE OUTBOARD ENGINE/TWIN UC128-OBF OR UC128-SVS CYLINDER TIE BAR

A93 - X LL

- Suitable for applications with triple outboard engines and dual cylinders UC128-OBF (or UC128-SVS)

Heavy duty triple engine/twin cylinder tie bar kit for use with UC128 and UC128P "Port" version outboard cylinders. Suitable for use with Protech and SilverSteer™ cylinders these AISI 304 electropolished and passivated stainless steel tie bars are simple to install and allow for independent trimming of engines with minimal effect on engine alignment.

ATTENTION: As the tiller arm position varies from engine to engine and the distance between two engines is not predictable, unexpected interferences may occur while tilting. A duly check of the tie bar installation is then strongly recommended. Should you need additional information, please do not hesitate to refer to our Technical Service.



A93

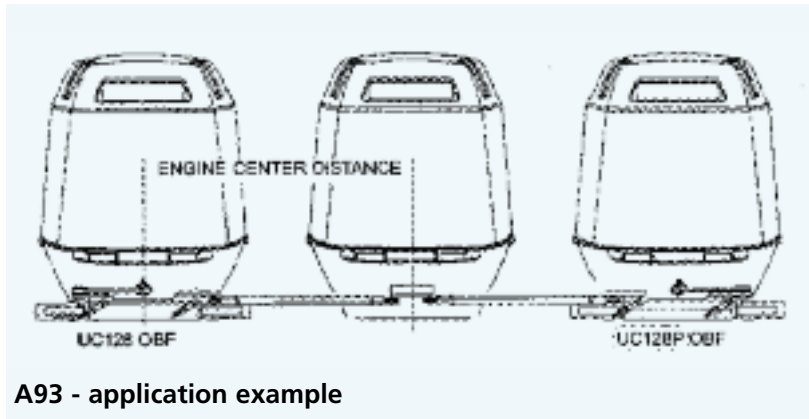
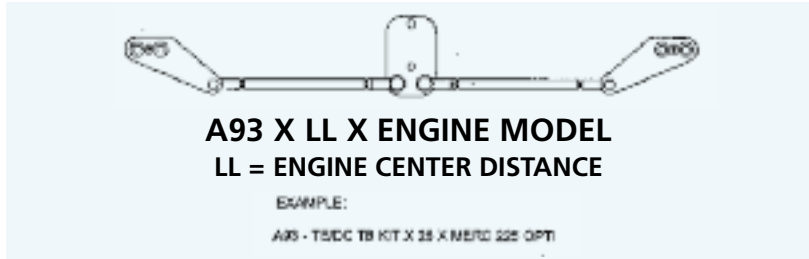

A93 - application example



Photo courtesy of Donzi Marine

HYDRAULIC TIE BAR

LTB1

Hydraulic Tie Bar for twin engine / twin cylinder applications where a mechanical tie bar is not feasible. Engine centers must be at least 38" wide as engine can periodically misalign. It connects using standard Kit OB or Kit OBBHBR hoses.



LTB1

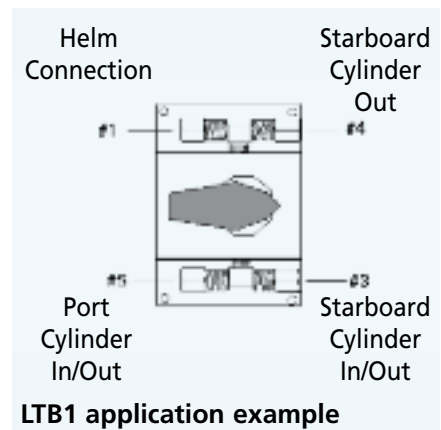

LTB1 application example



STERNDRIVE CYLINDERS

WARNING:
Not intended for use
with SilverSteer™ SVS
Series helms.

62

STERNDRIVE STEERING



UC133-IOB

Balanced cylinder: the number of turns lock to lock is equal port to starboard or vice-versa



UC132-OBS

Unbalanced cylinder: the number of turns lock to lock is not equal port to starboard or vice-versa

SPECIFICATIONS	UC133-IOB - 39429 M Balanced	UC132-OBS - 39430 W Unbalanced
Volume	132 cc - 8 cu. in	132 / 163 cc - 8 / 9.95 cu. in
Torque	66 kgm - - 5738 lbs. in	
Output force	464 kg -1023 lbs	464 / 574 kg - 1023 / 1265 lbs
Inside diameter	32 mm - 1.25"	32 mm - 1.25"
Stroke	203 mm - 8"	203 mm - 8"
3/8" (9,5 mm) Fittings	For high pressure flex hose	For high pressure flex hose

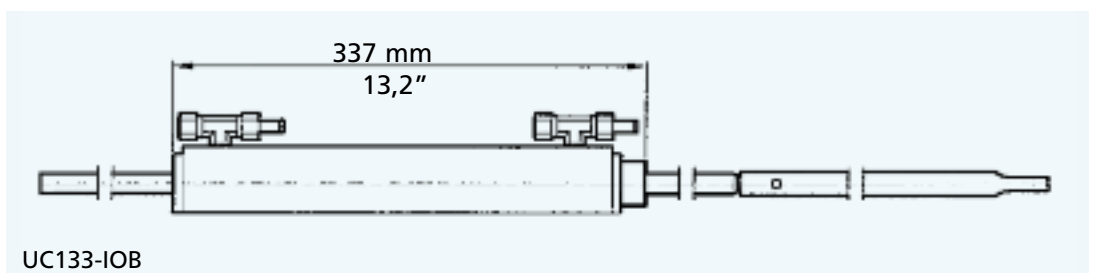
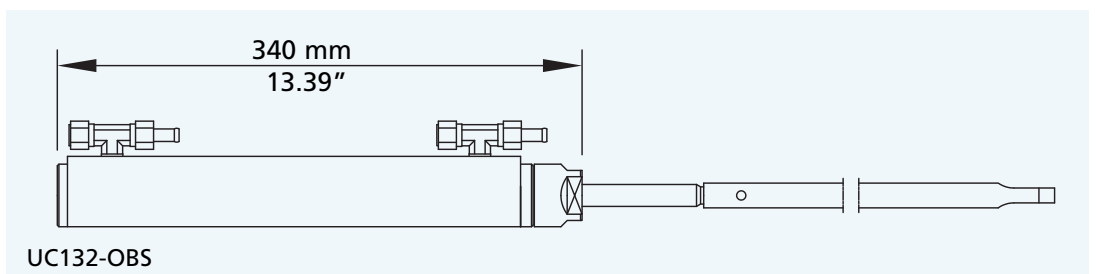

STERNDRIVE CYLINDERS

ENGINE	YEAR	MODEL	STERNDRIVE CYLINDERS			
			non power assist engine	see notes	power assisted engine	see notes
MERCUISER®	To date	ALPHA	UC133-IOB	1, 3	UC132-OBS	2
	To date	BRAVO ONE	UC133-IOB	1, 3	UC132-OBS	2
	To date	BRAVO TWO	UC133-IOB	1, 3	UC132-OBS	2
	To date	BRAVO THREE	UC133-IOB	1, 3	UC132-OBS	2
VOLVO®	To date	275	UC168-I	1, 3, 4	N/D	
	To date	280	UC133-IOB	1, 3, 4	UC132-OBS	2
	To date	290	UC133-IOB		UC132-OBS	2
	To date	DP-S	N/A		UC132-OBS	2

APPLICATIONS

WARNING These recommendations should be used as general reference only and they apply to factory stock sterndrives only. In doubt, contact a qualified installation technician.

- Balanced cylinder** the number of turns lock to lock is equal port to starboard or vice-versa
- Unbalanced cylinder** the number of turns lock to lock is not equal port to starboard or vice-versa
- Clearance required at the engine tube side: 21.2" (540 mm).**
- ULTRAFLEX hydraulic cylinder** can be installed as an alternative to a mechanical steering system only.

NOTE: For applications with sterndrive engines not listed above, please contact our Technical Service.

ORDER GUIDE

SYSTEM A			Turn lock to lock: Balanced 4.7 - Unbalanced 4.7/5.8 Max rudder torque: 66 kgm - 5738 lbs. in
Components	Model	Qtà	For an additional station add: 1 UP28 helm pump, 1 KIT OB-2S fitting kit, 1 KIT OB hose Kit, extra OIL 15, 1 steering wheel
Helm pump	UP28	1	
Cylinder	see application	1	
Hose Kit	KIT OB	1	
Oil	OIL 15	3	
Steering wheel	(Wheel selection)	1	
SYSTEM B			Turn lock to lock: Balanced 4 - Unbalanced 4/5 Max rudder torque: 66 kgm - 5738 lbs. in
Components	Model	Qtà	For an additional station add: 1 UP33 helm pump, 1 KIT OB-2S fitting kit, 1 KIT OB hose Kit, extra OIL 15, 1 steering wheel
Helm pump	UP33	1	
Cylinder	see application	1	
Hose Kit	KIT OB	1	
Oil	OIL 15	3	
Steering wheel	(Wheel selection)	1	

NOTE: 3/8" diameter copper tubing can be used as an alternative tubing for plumbing the systems. For these applications a fitting kit – KIT 95 – is required.

KIT 95 - 39516 G:

3/8" copper tube fitting kit. It includes two 1.6 ft (0,5 m) nylon tubes and all necessary fittings for a single station.



KIT 95





INBOARD CYLINDERS

64

INBOARD STEERING



UC116-I; UC168-I; UC215-I

All balanced cylinders: the number of turns lock-to-lock is equal port to starboard and vice-versa

SPECIFICATIONS	UC116-I - 39431 Y Alluminum	UC168-I - 39432 A Alluminum	UC215-I - 39433 C Alluminum
Volume	116 cc - 7 cu. in	168 cc - 10.25 cu.in	215 cc - 13.12 cu. in
Torque	58 kgm - 5043 lbs. in	87 kgm - 7565 lbs. in	111 kgm - 9652 lbs. in
Output force	464 kg - 1023 lbs	673 kg - 1483 lbs	673 kg - 1483 lbs
Inside diameter	32 mm - 1.25"	40 mm - 1.57"	40 mm - 1.57"
Stroke	178 mm - 7"	178 mm - 7"	228 mm - 9"
3/8" (9,5 mm) Fittings	For high pressure flex hose	For high pressure flex hose	For high pressure flex hose

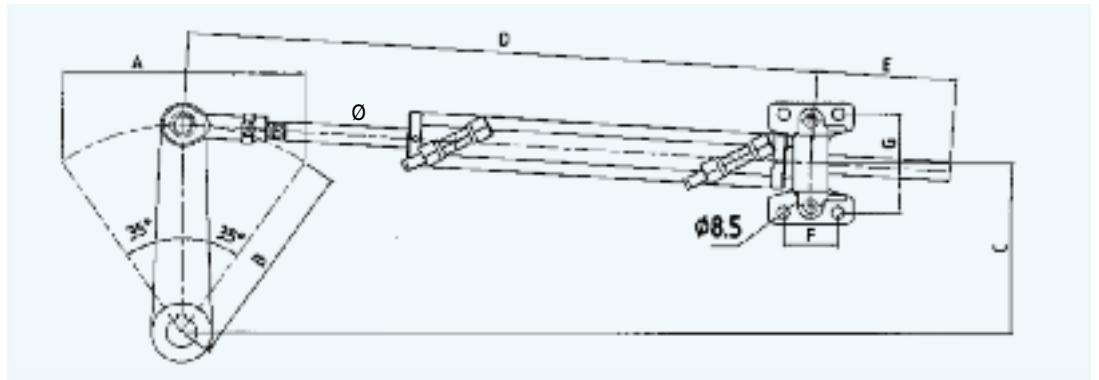

	UC116-I	UC168-I	UC215-I
A	178 mm - 7"	178 mm - 7"	228 mm - 9"
B	155 mm - 6.1"	155 mm - 6.1"	199 mm - 7.8"
C	127 mm - 5"	127 mm - 5"	163 mm - 6.4"
D	466 mm - 18.3"	512 mm - 20.1"	587 mm - 23.1"
E	102 mm - 4"	107.5 mm - 4.2"	132.5 mm - 5.2"
F	40 mm - 1.6"	40 mm - 1.6"	40 mm - 1.6"
G	73 mm - 2.9"	105 mm - 4.1"	105 mm - 4.1"
Rod Ø	14 mm - 0.6"	20 mm - 0,8"	20 mm - 0,8"





UC293-I; UC378-I

Balanced: the number of turns lock-to-lock is equal port to starboard or vice-versa.

SPECIFICATIONS	UC293-I - 40246 L Brass	UC378-I - 40810 P Brass
Volume	293 cc - 17.8 cu. in	376 cc - 22.94 cu. in
Torque	146,5 kgm - 12816 lbs. in	187,6 kgm - 16347 lbs. in
Output force	1155 kg - 2545 lbs	1155 kg - 2545 lbs
Inside diameter	50 mm - 1.97"	50 mm - 1.97"
Stroke	178 mm - 7"	228 mm - 9"
Fittings	3/8" (9,5 mm) for high pressure flex hose	for 0.5" (12 mm) copper tube (flexible connection hoses included)

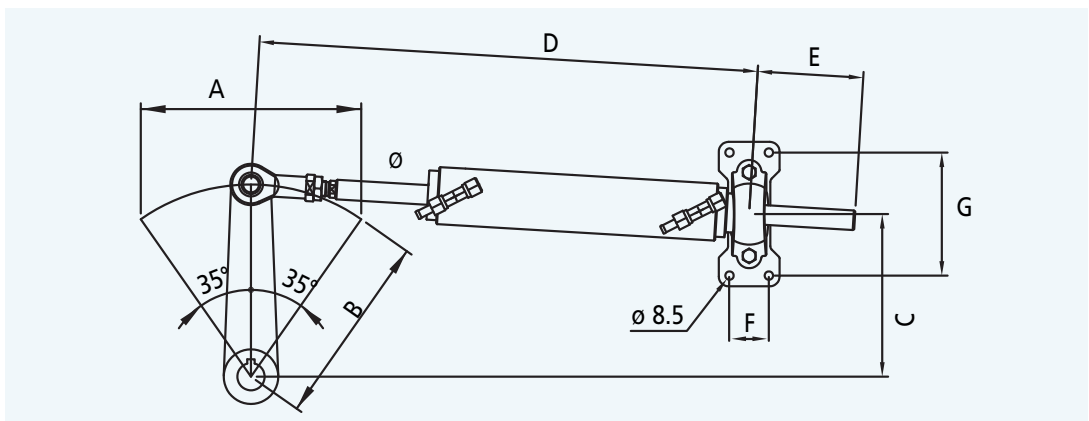

	UC293-I	UC378-I
A	178 mm - 7"	228 mm - 9"
B	163 mm - 6.4"	199 mm - 7.8"
C	134 mm - 5.2"	163 mm - 6.4"
D	506 mm - 19.9"	592 mm - 23.3"
E	107 mm - 4.2"	132,5 mm - 5.2"
F	40 mm - 1.6"	40 mm - 1.6"
G	125 mm - 4.9"	125 mm - 4.9"
Rod Ø	20 mm - 0.8"	20 mm - 0.8"



INBOARD CYLINDERS



UC69-I - Balanced: the number of turns lock-to-lock is equal port to starboard or vice-versa.

66

WARNING: UC69-I cylinder is suitable for inboard boats up to approx. 24 - 26 ft (7,5 - 8 m) length and 25 mph max speed.

SPECIFICATIONS	UC69-I - 39782 E
Volume	69 cc - 4.2 cu. in
Torque	32 kgm - 2783 lbs. in
Output force	168 kg - 371 lbs
Inside diameter	25 mm - 0.98"
Stroke	150 mm - 5.9"
3/8" (9,5 mm) Fittings	For high pressure flex hose

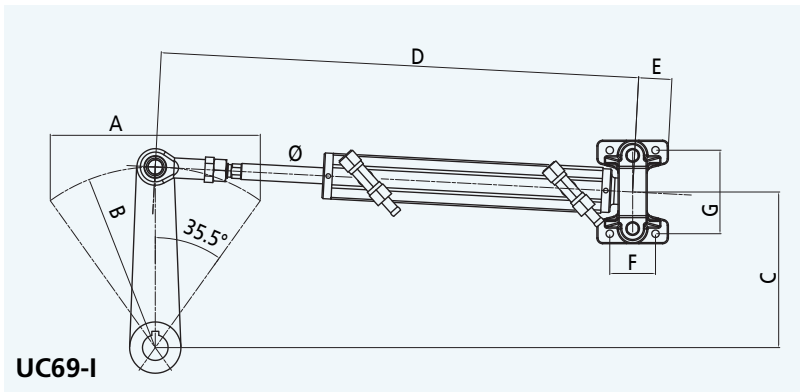

A	150 mm - 5.9"
B	129 mm - 5.11"
C	136 mm - 5.35"
D	417 mm - 16.42"
E	31,3 mm - 1.23"
F	40 mm - 1.57"
G	73 mm - 2.87"
Rod Ø	14 mm - 0.6"

INBOARD CYLINDER APPLICATIONS

WARNING: These recommendations should be used as a general reference only. Final selection should be made with the assistance of a qualified installation technician. For any further information please contact our Technical Service.

ATTENTION: Beside boat length and hull configuration, boat speed and rudder torque are key factors when selecting the appropriate system for your boat. Our inboard systems are not recommended for use in installations where the boat speed exceeds 28 mph (28 knots) (boat with planing hull) or 18 mph (18 knots) (boat with displacement hull).

CYLINDER	MAX BOAT LENGTH	HULL TYPE	NO. OF ENGINES	MAX TORQUE	HOW TO ORDER
UC116-I	8,50 m - 28 ft	Planing/ Displacement	1	58 kgm 5043 lbs. in	System 1
	9,50 m - 31 ft		2		System 1
UC168-I	11,60 m - 38 ft	Planing	1	87 kgm 7565 lbs. in	System 2
	13,40 m - 44 ft		2		
	9,70 m - 32 ft	Displacement	1		System 2
	11,60 m - 38 ft		2		
UC215-I	13,40 m - 44 ft	Planing	1	111 kgm 9652 lbs. in	System 3
	15,20 m - 50 ft		2		
	11,60 m - 38 ft	Displacement	2		System 3
	13,40 m - 44 ft		2		
UC293-I	16,00 m - 58 ft	Planing	1	147 kgm 12816 lbs. in	System 4
	18,30 m - 60 ft		2		
	14,00 m - 46 ft	Displacement	2		System 4
	18,30 m - 60 ft		2		

**INBOARD
CYLINDERS**

ORDER GUIDE

NOTE: With systems 1 and 2, a 3/8" nylon tubing (TU95) can be used as an alternative to the standard KIT OB hose kit for plumbing the system. For these applications the fitting kit for the additional station is KIT95-2S.

NOTE: With systems 1, 2, 3, 4 and 5 copper tubing (3/8" dia) can be used as an alternative tubing for plumbing the system. For these applications a fitting kit, KIT 95, is required. For applications on commercial boats, the use of copper tubing is recommended.

SYSTEM 1		Turn lock to lock: 4,6 (UP25) or 4,1 (UP28) Max rudder torque: 58 kgm (5043 lbs. in)	
Components	Model	Qty	For additional station add: 1 UP25 or UP28 helm pump, 1 KIT OB-2S fitting kit, 1 KIT OB hose Kit, extra OIL 15, 1 steering wheel
Helm pump	UP25 or UP28	1	
Cylinder	UC116-I	1	
Hose Kit	KIT OB	1	
Oil	OIL 15	3	
Steering wheel	(Wheel selection)	1	

SYSTEM 2		Turn lock to lock: 6 (UP28) or 5 (UP33) Max rudder torque: 87 kgm (7565 lbs. in)	
Components	Model	Qty	For additional station add: 1 UP28 or UP33 helm pump, 1 KIT OB-2S fitting kit, 1 KIT OB hose Kit, extra OIL 15, 1 steering wheel
Helm pump	UP28 or UP33	1	
Cylinder	UC168-I	1	
Hose Kit	KIT OB	1	
Oil	OIL 15	3	
Steering wheel	(Wheel selection)	1	

SYSTEM 3		Turn lock to lock: 6,5 (UP33) or 5,5 (UP39) Max rudder torque: 111 kgm (9652 lbs. in)	
Components	Model	Qty	For additional station add: 1 UP33 or UP39 helm pump, 1 KIT OB-2S fitting kit, 1 KIT OB hose Kit, extra OIL 15, 1 steering wheel
Helm pump	UP33 or UP39	1	
Cylinder	UC215-I	1	
Hose Kit	KIT OB	1	
Oil	OIL 15	3	
Steering wheel	(Wheel selection)	1	

SYSTEM 4		Turn lock to lock: 7,5 (UP39) or 6,5 (UP45) Max rudder torque: 146,5 kgm (12816 lbs. in)	
Components	Model	Qty	For additional station add: 1 UP39 or UP45 helm pump, 1 KIT OB-2S fitting kit, 1 KIT OB hose Kit, extra OIL 15, 1 steering wheel
Helm pump	UP39 or UP45	1	
Cylinder	UC293-I	1	
Hose Kit	KIT OB	1	
Oil	OIL 15	3	
Steering wheel	(Wheel selection)	1	

SYSTEM 5		Turn lock to lock: 8,4 Max rudder torque: 187,6 kgm (16347 lbs. in)	
Components	Model	Qty	For additional station add: 1 UP45-I R helm pump, 1 KIT 120-2S fitting kit, extra OIL 15, 1 steering wheel
Helm pump	UP45-I R	1	
Cylinder	UC378 I	1	
Oil	OIL 15	3	
Steering wheel	(Wheel selection)	1	





BULKHEAD HOSE KITS

R7 - 3/4" BULKHEAD FITTING KIT

3/4" bulkhead fitting kit for single cylinder installation. 2 assemblies as illustrated per kit. R7 - 40819 J



R7 KIT

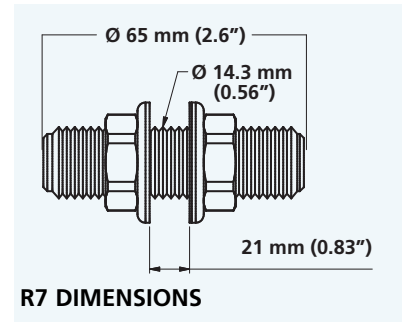

R7 DIMENSIONS

68

R8 - DUAL THRU-HULL HOSE KIT

Connection flange available in three different colours

R8B - Black 41299 P

R8W - White 41300 V

R8CH - Chrome 41301 X



R8B



R8W



R8CH

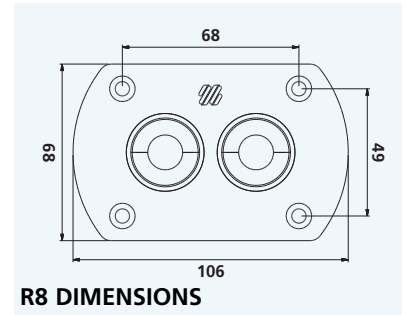

R8 DIMENSIONS

R9 - BULKHEAD KIT FOR DUAL HOSE WITH PREASSEMBLED FITTINGS

Connection flange available in three different colours

R9B - Black 41302 Z

R9W - White 41303 B

R9CH - Chrome 41304 D



R9B



R9W



R9CH

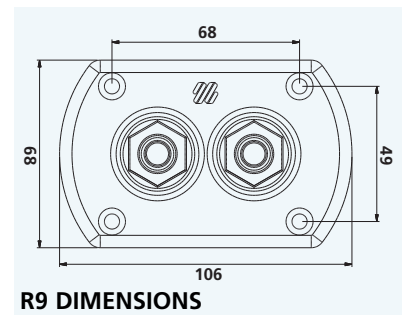

R9 DIMENSIONS

ACCESSORIES

TU95:

3/8" nylon tubing. It is not recommended in the applications where the total tubing run exceeds 50 ft (15 m). Not recommended for use with UC128 an UC128-SVS cylinders.

KIT 95-2S - 39518 L:

Fitting kit for a second steering station or for an autopilot installation. It includes all necessary fittings for 3/8" nylon or copper tube.

BP 95 - 39520 X:

By-pass for 3/8" nylon tube.

OIL 15 - 70704 K:

Sold in 1 quart (0.26 gallons) container

- Hydraulic oil: ISO VG 15
- Viscosity: 15 cst a 40 °C
- Viscosity index: <100
- Solidification point: <- 30 °C

KIT F - 39664 Y:

Remote fill adapter for rear mount and tilt mount pumps.



KIT 95-2S



BP 95



OIL 15



KIT F

FITTINGS

61BCA - 71004 K

3/8" (9,5 mm) nut and sleeve assembly, brass

61CA - 71013 L

3/8" (9,5 mm) nut and sleeve assembly, nickel plated

AF45 - 41284 A

45° adjustable fitting, helm and tube. Suitable for SilverSteer™ system **only**.

SF38 - 39471 L

3/8" (9,5 mm) connector fitting, helm and tube

SF12 - 41306 H

straight fitting, helm and tube Ø 12 mm

EF38 - 39472 N

3/8" (9,5 mm) elbow fitting, helm and tube

TF38 - 39502 V

3/8" (9,5 mm) union T for tube

VF38 - 39503 X

3/8" (9,5 mm) bleed T for cylinder, brass

VFN38 - 39925 A

3/8" (9,5 mm) bleed T for cylinder, nickel plated

VFNO38 - 40868 Y

3/8" (9,5 mm) adjustable bleed T for cylinder, nickel plated, for all cylinders except UC94-OBF with serial number up to 30 1156 000001

QCFN - 41307 K

Quick connect bleed T for cylinder, nickel plated, for all cylinders except UC94-OBF with serial number up to 30 1156 000001

QCFN94 - 41308 M

Quick connect bleed T for cylinder, nickel plated with DN5 quick connect, for all cylinders except UC94-OBF with serial number up to 30 1156 000001

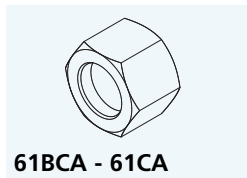

61BCA - 61CA



AF45



SF38

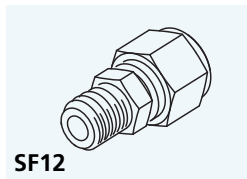

SF12



EF38



TF38



VF38 - VFN38



VFNO38

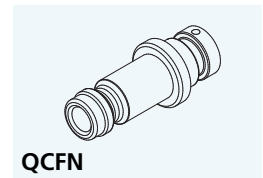

QCFN



QCFN94

HYDRAULIC CROSS REFERENCE GUIDE



70

HYDRAULIC CROSS REFERENCE GUIDE

UFLEX® PART No.	TELEFLEX® CROSS REFERENCE	DESCRIPTION
HYDRAULIC HELM UNITS - FRONT MOUNT		
UP20FM	HH5270	FRONT MOUNT HELM, 1.2 CU.IN. 3/4" ANODIZED ALUM. TAPERED SHAFT
UP25FM	HH5271	FRONT MOUNT HELM, 1.5 CU.IN. 3/4" TAPERED STAINLESS STEEL SHAFT
UP28FM	HH5271	FRONT MOUNT HELM, 1.7 CU.IN. 3/4" TAPERED STAINLESS STEEL SHAFT
UP33FM	HH5273	FRONT MOUNT HELM, 2.0 CU.IN. 3/4" TAPERED STAINLESS STEEL SHAFT
UP39FM	HH5272	FRONT MOUNT HELM, 2.4 CU.IN. 3/4" TAPERED STAINLESS STEEL SHAFT
HYDRAULIC HELM UNITS - TILT MOUNT		
UP20T	HH5291 or HH5740 or HH4315	TILT HELM, 1.2 CU.IN. 3/4" TAPERED SS SHAFT (X52 TILT INCLUDED & KIT F OPTIONAL)
UP25T	HH5291 or HH5741 or HH6191 or HH6491 or HH6541	TILT HELM, 1.5 CU.IN. 3/4" TAPERED SS SHAFT (X52 TILT INCLUDED & KIT F OPTIONAL)
UP28T	HH5291 or HH5741 or HH6191 or HH6491 or HH6541	TILT HELM, 1.7 CU.IN. 3/4" TAPERED SS SHAFT (X52 TILT INCLUDED & KIT F OPTIONAL)
UP33T	HH5290 or HH5774 or HH6145 or HH6490	TILT HELM, 2.0 CU.IN. 3/4" TAPERED SS SHAFT (X52 TILT INCLUDED & KIT F OPTIONAL)
UP39T	HH5292 or HH5742 or HH6192 or HH6492 or HH6542	TILT HELM, 2.4 CU.IN. 3/4" TAPERED SS SHAFT (X52 TILT INCLUDED & KIT F OPTIONAL)
HYDRAULIC HELM UNITS - REAR MOUNT		
UP28R	HH5261	BACK MOUNT 1.7 CU.IN. 3/4" TAPERED SS SHAFT *(KIT F OPTIONAL)
UP33R	HH5262	BACK MOUNT 2.0 CU.IN. 3/4" TAPERED SS SHAFT *(KIT F OPTIONAL)
UP39R	HH5263	BACK MOUNT 2.4 CU.IN. 3/4" TAPERED SS SHAFT *(KIT F OPTIONAL)
UP56R	HH5263	BACK MOUNT 3.4 CU.IN. 3/4" TAPERED SS SHAFT
SILVER STEER HI PERFORMANCE 1500 PSI HYDRAULIC HELM UNITS		
UP28F-SVS	HH5770	1500 PSI-HIGH PERFORMANCE FRONT MOUNT HELM, 1.7 CU.IN. 3/4" TAPERED SS SHAFT
UP33F-SVS	HH5770	1500 PSI-HIGH PERFORMANCE FRONT MOUNT HELM, 2.0 CU.IN. 3/4" TAPERED SS SHAFT
UP39F-SVS	HH5770	1500 PSI-HIGH PERFORMANCE FRONT MOUNT HELM, 2.4 CU.IN. 3/4" TAPERED SS SHAFT
UP28T-SVS	HH5290 or HH5774 or HH6189	1500 PSI-HIGH PERFORMANCE TILT HELM, 1.7 CU.IN. TAPERED SS *(X70 TILT & KIT F OPTIONAL)
UP33T-SVS	HH5290 or HH5774 or HH6190	1500 PSI-HIGH PERFORMANCE TILT HELM, 2.0 CU.IN. TAPERED SS *(X70 TILT & KIT F OPTIONAL)
UP39T-SVS	HH5290 or HH5774 or HH6188	1500 PSI-HIGH PERFORMANCE TILT HELM, 2.0 CU.IN. TAPERED SS *(X70 TILT & KIT F OPTIONAL)
OUTBOARD APPLICATION CYLINDERS (See application chart)		
UC128OBF 1	HC5345 or HC5358	CYLINDER, 1.38" BORE, 7.8" STROKE, FRONT MOUNT - # 1 LINK ARM
UC128OBF 2	HC5345 or HC5358	CYLINDER, 1.38" BORE, 7.8" STROKE, FRONT MOUNT - # 2 LINK ARM
UC128OBF 3	HC5345 or HC5358	CYLINDER, 1.38" BORE, 7.8" STROKE, FRONT MOUNT - # 3 LINK ARM
UC128POBF 1	HC5345 or HC5358	CYLINDER, 1.38" BORE, 7.8" STROKE, FRONT MOUNT - PORT ENGINE CYLINDER - # 1 LINK ARM
UC128POBF 2	HC5345 or HC5358	CYLINDER, 1.38" BORE, 7.8" STROKE, FRONT MOUNT - PORT ENGINE CYLINDER - # 2 LINK ARM
UC128POBF 3	HC5345 or HC5358	CYLINDER, 1.38" BORE, 7.8" STROKE, FRONT MOUNT - PORT ENGINE CYLINDER - # 3 LINK ARM
SILVER STEER OUTBOARD APPLICATION CYLINDERS (See application chart)		
UC128-SVS 1	HC5345 or HC5358 or HC6750 or HC6751 or HC6752	HIGH PERFORMANCE CYLINDER, 1.38" BORE, 7.8" STROKE, FRONT MOUNT - # 1 LINK ARM
UC128-SVS 2	HC5345 or HC5358 or HC6750 or HC6751 or HC6752	HIGH PERFORMANCE CYLINDER, 1.38" BORE, 7.8" STROKE, FRONT MOUNT - # 2 LINK ARM
UC128P-SVS 1	HC5345 or HC5358 or HC67502 or HC6751 or HC675	HIGH PERFORMANCE CYLINDER, 1.38" BORE, 7.8" STROKE, FRONT MOUNT-PORT ENGINE CYLINDER- # 1 LINK ARM
UC128P-SVS 2	HC5345 or HC5358 or HC6750 or HC6751 or HC6752	HIGH PERFORMANCE CYLINDER, 1.38" BORE, 7.8" STROKE, FRONT MOUNT-PORT ENGINE CYLINDER- # 2 LINK ARM
LOW HP OUTBOARD APPLICATION CYLINDERS (See application chart)		
UC94OBF 1	HC4645H or HC4647H or HC4658H	CYLINDER, 1.18" BORE, 7.3" STROKE, FRONT MOUNT (150 HORSEPOWER AND UNDER) - # 1 LINK ARM
UC94OBF 3	HC4645H	CYLINDER, 1.18" BORE, 7.3" STROKE, FRONT MOUNT (150 HORSEPOWER AND UNDER) - # 3 LINK ARM
SIDEMOUNT OUTBOARD CYLINDER		
UC132-OBS	HC5370	CYLINDER, 1.26" BORE, 8.0" STROKE, SIDE MOUNT

HYDRAULIC CROSS REFERENCE GUIDE



71

UFLEX® PART No.	TELEFLEX® CROSS REFERENCE	DESCRIPTION
HYCO OUTBOARD STEERING PACKAGES (See application chart)		
HYCO 1.0	HK4200a - BayStar®	FRONT MOUNT OUTBOARD SYSTEM FOR 150 HP AND LESS
PROTECH OUTBOARD STEERING PACKAGES (See application chart)		
PROTECH 1.0	HK6300 or HK6400 SeaStar®	FRONT MOUNT OUTBOARD SYSTEM
PROTECH 2.0	HK6300 or HK6400 SeaStar®	FRONT MOUNT OUTBOARD SYSTEM
PROTECH 3.0	HK6300 or HK6400 SeaStar®	FRONT MOUNT OUTBOARD SYSTEM
PROTECH 1T	HK6400TC or HK6400TS	FRONT MOUNT OUTBOARD SYSTEM WITH TILT HELM
	or HK6500YTC SeaStar®	
PROTECH 2T	HK6400TC or HK6400TS	FRONT MOUNT OUTBOARD SYSTEM WITH TILT HELM
	or HK6500YTC SeaStar®	
PROTECH 3T	HK6400TC or HK6400TS	FRONT MOUNT OUTBOARD SYSTEM WITH TILT HELM
	or HK6500YTC SeaStar®	
PROTECH SS OUTBOARD STEERING PACKAGES (See application chart)		
PROTECH SS 1.0	HK7300 or HK7400 SeaStar Pro®	FRONT MOUNT OUTBOARD SYSTEM WITH 1500 PSI HELM AND STANDARD UC128 1 CYLINDER
PROTECH SS 2.0	HK7300 or HK7400 SeaStar Pro®	FRONT MOUNT OUTBOARD SYSTEM WITH 1500 PSI HELM AND STANDARD UC128 2 CYLINDER
PROTECH SST 1.0	HK7400 SeaStar Pro®	FRONT MOUNT OUTBOARD SYSTEM WITH 1500 PSI TILT HELM AND STANDARD UC128 1 CYLINDER
PROTECH SST 2.0	HK7400 SeaStar Pro®	FRONT MOUNT OUTBOARD SYSTEM WITH 1500 PSI TILT HELM AND STANDARD UC128 2 CYLINDER
SILVER STEER OUTBOARD STEERING PACKAGES (See application chart)		
SILVER STEER 1.0	HK7300 or HK7400 SeaStar Pro®	1500PSI HI-PERFORMANCE FRONT MOUNT OUTBOARD SYSTEM
SILVER STEER 2.0	HK7300 or HK7400 SeaStar Pro®	1500PSI HI-PERFORMANCE FRONT MOUNT OUTBOARD SYSTEM
SILVER STEER T 1.0	HK7300 or HK7400 SeaStar Pro®	1500PSI HI-PERFORMANCE FRONT MOUNT OUTBOARD SYSTEM WITH TILT HELM
SILVER STEER T 2.0	HK7300 or HK7400 SeaStar Pro®	1500PSI HI-PERFORMANCE FRONT MOUNT OUTBOARD SYSTEM WITH TILT HELM
HD SERIES INBOARD APPLICATION CYLINDERS		
UC116-I	HC5312	ALUMINUM CYLINDER, 1.25" BORE, 7" STROKE, BALL JOINT
UC168-I	HC5314 or HC5318	ALUMINUM CYLINDER, 1.57" BORE, 7" STROKE, BALL JOINT
UC215-I	HC5313	ALUMINUM CYLINDER, 1.57" BORE, 9" STROKE, BALL JOINT
UC293-I	HC5314	BRASS CYLINDER, 2.0" BORE, 7" STROKE, BALL JOINT
UC378-I	HC5378 or HC5379	BRASS CYLINDER, 2.0" BORE, 9" STROKE, BALL JOINT
I-B648	HC5378 or HC5379	CYLINDER, 2.36" BORE, 11" STROKE, BALL JOINT
STERNDRIIVE APPLICATION CYLINDERS		
UC133-IOB	HC5330 or HC5332	CYLINDER, 1.26" BORE, 8" STROKE, BALANCED
UC132-OBS	HC5328	CYLINDER, 1.26" BORE, 8" STROKE, UNBALANCED
HYDRAULIC PARTS AND ACCESSORIES		
BBUSTER	POWER PURGE®	PURGING SYSTEM FOR UFLEX HYDRAULIC STEERING SYSTEMS
KIT F	HA5450	REMOTE FILL KIT OF UP TILT HELMS AND UP REAR MOUNT HELMS
OIL 15	HA5430	UFLEX HYDRAULIC OIL, 1 QUART
X64	HA5417 or HA5418	SQUARE BEZEL FOR HYDRAULIC HELMS
X57	HA5417 or HA5419	ROUND BEZEL FOR HYDRAULIC HELMS
KIT OB-LL	HO51LL	PREMADE HYDRAULIC HOSES
KIT OB BHBR-LL	HO81LL	PREMADE HYDRAULIC HOSES WITH BULKHEAD BEND RESTRICTORS
KITOB SVS-LL	HO81LL	TWO FLEXIBLE HOSES SILVER STEER HIGH PERFORMANCE
TU95-LL	HT5LL	NYLON TUBE IN 1 FT. INCREMENTS (NOT RECOMMENDED FOR OUTBOARD APPLICATIONS)
KIT 95 2S	HF5501	ADDITIONAL STATION FITTING KIT FOR 3/8" NYLON OR COPPER TUBE

NOTE: This cross reference is intended to be a general guide. Some of the products may have variances that would not make them interchangeable. We recommend that you contact Technical Service for more details.



BubbleBuster™

A PORTABLE DEVICE FOR AUTOMATIC FILLING AND PURGING OF HYDRAULIC SYSTEMS

72

Reduce time and simplify purging hydraulic steering systems with the self contained and portable BubbleBuster™ purging unit.

Attach the hoses using the quick connect fittings to the helm and cylinder and with the push of a button the BubbleBuster™ begins cycling oil throughout the entire systems free of air.

The system features a ZeroEmulsion pump, a 4 quart capacity reservoir and is compatible with competing helms and cylinders.

COMPONENTS INCLUDED

- No. 1 motor pump with safety valve , switch and 5 litres (1 gal) tank included, it allows the purging of 2 hydraulic steering systems before refilling. 12v electric motor with thermal protection; current absorption 8 A
- No. 1 4m (13') electric harness with alligator clips for fast connection with the battery.
- No. 1 double spiralled hose to connect to helm pump- extended length: 6m (19,6')
- No. 1 double spiralled hose to connect to cylinder – extended length: 6m (19,6')
- No. 1 utility tray

OPTIONAL COMPONENTS

- **KBE1:** No. 1 double spiralled hose to connect to cylinder 15 m (49') extension
- **KBD2:** No. 1 kit for double cylinder systems filling and purge
- **KH94:** Connection kit for UC94-OBF cylinders with old bleeders (not fast connect)
- **KH128:** Connection kit for cylinders (except UC94) with old bleeders (not fast connect)



BubbleBuster™

MODEL	P. No.	DESCRIPTION
BB	41666 R	BubbleBuster™ - complete set
KBE1	41682 N	Extension kit
KBD2	41703 U	Double cylinder purging kit
KH94	41899 R	UC94 (old) connection kit
KH128	41900 W	Connection kit for cylinders with old fittings (except UC94)





STEERING WHEELS

All ULTRAFLEX steering wheels meet the EEC directive 94/25 requirements about pleasure boats. All steering wheels are CE marked in conformity with the EN 28848 – EN 29775 and ABYC P22 safety standards

- Thermoplastic antishock material
- Standard 3/4" taper
- Complete with hub
- Meet with the EN 28848 and ABYC P22 standards

V32 - 35458 X Black
 V33 - 35819 L Black
 V33G - 37495 J Grey

SOFT TOUCH GRIP

V45 - 37920 H Black
 V45W - 38049 P White



V32 Ø 13.2" (335 mm)



V33 Ø 13.4" (342 mm)



V33G Ø 13.4" (342 mm)



V45 Ø 11" (280 mm)



V45W Ø 11" (280 mm)

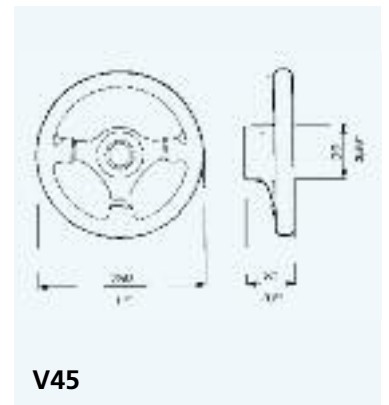
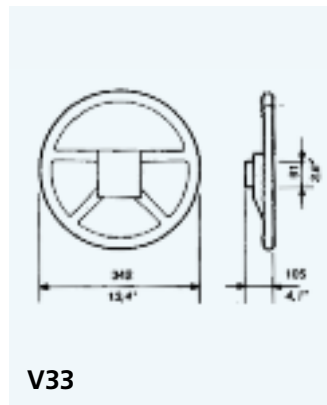
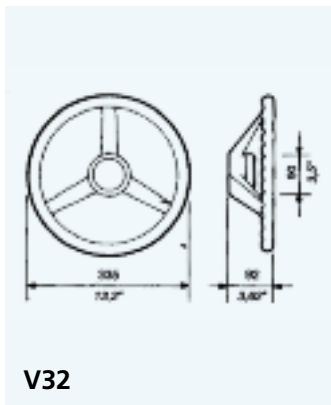

ANTIGUA STEERING WHEELS

All ULTRAFLEX steering wheels meet the EEC directive 94/25 requirements about pleasure boats. All steering wheels are CE marked in conformity with the EN 28848 – EN 29775 and ABYC P22 safety standards

- Thermoplastic antishock material
- Standard 3/4" taper
- Hub included
- Meet with the EN 28848 and ABYC P22 standards

SOFT TOUCH GRIP

- V60B - 39189 U
- V60W - 39190 C
- V60G - 39274 J

WOOD LOOK OR PAINTED GRIP

- V61B - 39191 E

BURL WOOD CAP

- BRC - 70166 H



V60B Black grip - Black spokes
Ø 13.8" (350 mm)



V60W White grip - White spokes
Ø 13.8" (350 mm)



V60G Grey grip - Grey spokes
Ø 13.8" (350 mm)



V61B Burl wood grip
Black spokes - Ø 13.8" (350 mm)



BRC Burl wood center cap for all
Antigua wheels Ø 13.8" (350 mm)



All Antigua steering wheels are provided with an exclusive hub that easily allows the steering wheel to always be aligned properly.

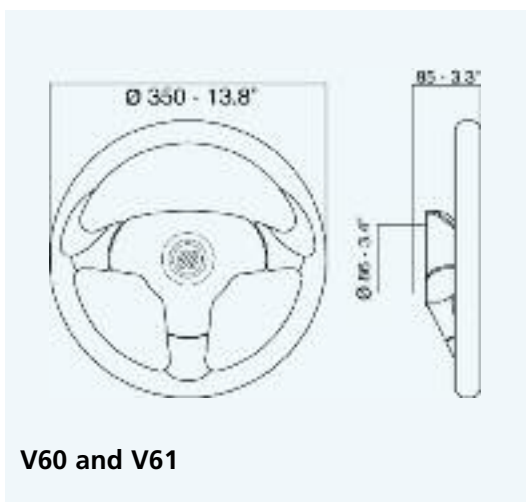

V60 and V61





CORSE STEERING WHEELS

All ULTRAFLEX steering wheels meet the EEC directive 94/25 requirements about pleasure boats. All steering wheels are CE marked in conformity with the EN 28848 – EN 29775 and ABYC P22 safety standards

- Standard 3/4" taper
- Hub included
- Meet with the EN 28848 and ABYC P22 standards
- X63 - 40119 D hub with button

SOFT TOUCH GRIP

- CORSE B/S - 38333 O
- CORSE B/B - 38332 N
- CORSE W/S - 38334 P
- CORSE G/S - 38393 H

CORSE BURL COVER

- CBC - 73706 F

CENTER RINGS (OPTIONAL)

- RING S – 61820 L silver



CORSE B/S Black grip - Silver spokes
Ø 13.8" (350 mm)



CORSE B/B Black grip - Black spokes
Ø 13.8" (350 mm)



CORSE W/S White grip - Silver spokes
Ø 13.8" (350 mm)



CORSE G/S Grey grip - Silver spokes
Ø 13.8" (350 mm)



CBC - Corse Burl Cover



X63 - easy centering hub

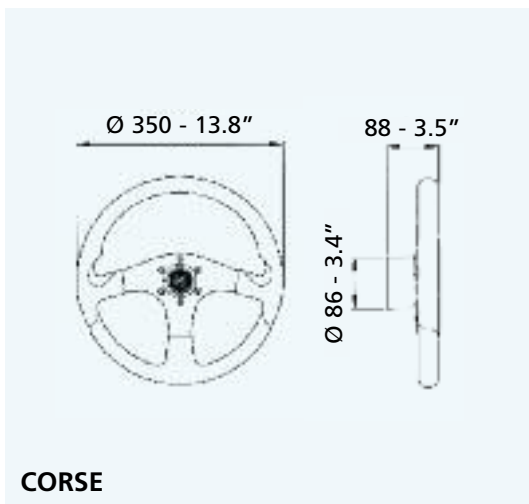

NISIDA, SPARGI, VIVARA STEERING WHEELS

All UFLEX steering wheels meet the EEC directive 94/25 requirements about pleasure boats. All steering wheels are CE marked in conformity with the EN 28848 - EN 29775 and ABYC P22 safety standards

- Standard 3/4" taper
- Hub included
- Meet with the EN 28848 and ABYC P22 standards

POLYURETHANE SOFT TOUCH GRIP

NISIDA B/B - 61812 M
NISIDA B/S - 61813 P

BLACK SOFT TOUCH GRIP WITH INSERTS

SPARGI BR/B - 61814 S
SPARGI S/S - 61984 U
SPARGI BL/S - 62840 Y
SPARGI R/S - 62841 A
SPARGI Y/S - 62842 C
SPARGI PL/S - 62843 E

VIVARA CH/P - 64643 G
VIVARA CH/B - 64644 J

CENTER RING (OPTIONAL)

RING S - 61820 L silver

ALSO AVAILABLE
POLISHED SPOKES FOR
ALL SPARGI WHEELS



NISIDA B/B Black grip - Black spokes
Ø 13.8" (350 mm)



NISIDA B/S Black grip - Silver spokes
Ø 13.8" (350 mm)



SPARGI BR/B Black grip - Burl wood
inserts - Black spokes - Ø 13.8" (350 mm)



SPARGI S/S Black grip - Silver inserts
Silver spokes - Ø 13.8" (350 mm)



SPARGI BL/S Black grip - Blue inserts
Silver spokes - Ø 13.8" (350 mm)



SPARGI R/S Black grip - Red inserts
Silver spokes - Ø 13.8" (350 mm)



VIVARA CH/P Chrome inserts
Polished spokes - Ø 13.8" (350 mm)



VIVARA CH/B Chrome inserts - Black spokes
Chrome center ring - Ø 13.8" (350 mm)



PALMARIA, GORGONA, LAVEZZI STEERING WHEELS

All UFLEX steering wheels meet the EEC directive 94/25 requirements about pleasure boats. All steering wheels are CE marked in conformity with the EN 28848 – EN 29775 and ABYC P22 safety standards

- Standard 3/4" taper
- Hub included
- Meet with the EN 28848 and ABYC P22 standards

POLYURETHANE SOFT TOUCH GRIP

PALMARIA B/B - 63727H
LAVEZZI B/S - 65295 R

POLYURETHANE SOFT TOUCH GRIP WITH INSERT

GORGONA CH/P - 67015 S
GORGONA CH/B - 65273 E
GORGONA CH/B/CP - 64302 D
LAVEZZI BL/S - 64724 G
LAVEZZI R/S - 64725 J

CENTER RING (OPTIONAL)

RING S - 61820 L silver



PALMARIA B/B Black grip
Black spokes - Ø 13.8" (350 mm)



GORGONA CH/P Chrome inserts
Polished spokes - Ø 13.8" (350 mm)



GORGONA CH/B Chrome insert
Black spokes - Ø 13.8" (350 mm)



GORGONA CH/B/CP Chrome inserts
Black spokes - Center pad - Ø 13.8" (350 mm)



LAVEZZI B/S Black grip
Silver spokes Ø 14.1" (360 mm)



LAVEZZI BL/S Blue painted inserts
Silver spokes - Ø 14.1" (360 mm)



LAVEZZI R/S Red painted inserts
Silver spokes - Ø 14.1" (360 mm)



Easy centering hub



PONZA, LINOSA, BUDELLI STEERING WHEELS

All UFLEX steering wheels meet the EEC directive 94/25 requirements about pleasure boats. All steering wheels are CE marked in conformity with the EN 28848 – EN 29775 and ABYC P22 safety standards

- Standard 3/4" taper
- Hub included
- Meet with the EN 28848 and ABYC P22 standards

120° THREE SPOKE WHEELS

- PONZA S/S - 61816 W
- PONZA S/P - 64294 H
- PONZA BL/S - 62845 J
- PONZA R/S - 62846 L
- PONZA Y/S - 62847 N
- PONZA PL/S - 62844 G

- LINOSA S/S - 64295 K
- LINOSA BR/B - 64296 M

POLYURETHANE SOFT TOUCH GRIP WITH INSERT

- BUDELLI CH/P - 65294 N
- BUDELLI CH/C/P - 66001 Z



PONZA S/S Silver grip - Silver spokes
Ø 13.8" (350 mm)



PONZA S/P Silver grip
Polished spokes - Ø 13.8" (350 mm)



PONZA BL/S Blue grip - Silver spokes
Ø 13.8" (350 mm)



PONZA R/S Red grip - Silver spokes
Ø 13.8" (350 mm)



LINOSA S/S Silver inserts
Silver spokes - Ø 13.8" (350 mm)



LINOSA BR/B Burl wood inserts
Black spokes - Ø 13.8" (350 mm)



BUDELLI CH/P Chrome inserts
Polished spokes - Ø 13.8" (350 mm)



BUDELLI CH/C/P Chrome inserts - Cream
grip - Polished spokes - Ø 13.8" (350 mm)





MAHOGANY STEERING WHEELS

All UFLEX steering wheels meet the EEC directive 94/25 requirements about pleasure boats. All steering wheels are CE marked in conformity with the EN 28848 – EN 29775 and ABYC P22 safety standards

- Standard 3/4" taper
- Hub included
- Meet with the EN 28848 and ABYC P22 standards

MAHOGANY GRIP

- LAMPEDUSA - 62684 L
- ALICUDI - 62682 G
- FILICUDI - 62683 J



LAMPEDUSA Ø 14.1" (360 mm)



ALICUDI Ø 13.8" (350 mm)



FILICUDI Ø 14.1" (360 mm)



Easy centering hub



**NON
MAGNETIC
STAINLESS
STEEL
WHEELS**

All ULTRAFLEX steering wheels meet the EEC directive 94/25 requirements about pleasure boats. All steering wheels are CE marked in conformity with the EN 28848 - EN 29775 and ABYC P22 safety standards

- Standard 3/4" taper
- Hub included
- Meet with the EN 28848 and ABYC P22 standards

POLYURETHANE GRIP

- V25B - 40640 R black
- V25W - 40642 V white
- V25G - 40641 T grey

MAHOGANY GRIP

- V26 - 40644 Z

STAINLESS STEEL GRIP

- V21 - 42121 A
- V27 - 40643 X

POLYURETHANE "FIRM GRIP"

- V21B - 42328 Z
- V21W - 42324 R



V25B Ø 13.8" (350 mm)



V25W Ø 13.8" (350 mm)



V25G Ø 13.8" (350 mm)



V26 Ø 13.8" (350 mm)



V27 Ø 13.8" (350 mm)



V21 Ø 350 mm (13.8")



V21B Ø 350 mm (13.8")



V21W Ø 350 mm (13.8")

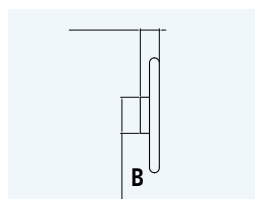

MOD.	B mm (")
V21	64 (2.5)
V25	57 (2.2)
V26	57 (2.2)
V27	57 (2.2)





**NON
MAGNETIC
STAINLESS
STEEL
WHEELS**

All ULTRAFLEX steering wheels meet the EEC directive 94/25 requirements about pleasure boats. All steering wheels are CE marked in conformity with the EN 28848 – EN 29775 and ABYC P22 safety standards

- Standard 3/4" taper
- Hub included
- Meet with the EN 28848 and ABYC P22 standards

**POLYURETHANE
GRIP**

- V01 - 41687 Z black
- V02 - 41688 B white
- V03 - 41689 D grey
- V04 - 41690 M navy blue

MAHOGANY GRIP

- V05 - 41691 P

**STAINLESS STEEL
GRIP**

- V06 - 41692 S



V01 Ø 13.8" (350 mm)



V02 Ø 13.8" (350 mm)



V03 Ø 13.8" (350 mm)



V04 Ø 13.8" (350 mm)



V05 Ø 13.8" (350 mm)



V06 Ø 13.8" (350 mm)

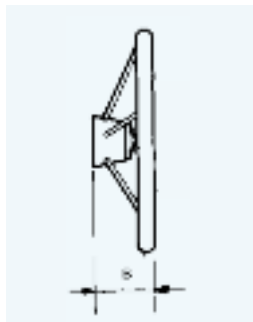

MOD.	B mm (")
V01	67 (2.6)
V02	67 (2.6)
V03	67 (2.6)
V04	67 (2.6)
V05	67 (2.6)
V06	67 (2.6)



**NON
MAGNETIC
STAINLESS
STEEL
WHEELS**

All ULTRAFLEX steering wheels meet the EEC directive 94/25 requirements about pleasure boats. All steering wheels are CE marked in conformity with the EN 28848 – EN 29775 and ABYC P22 safety standards

- Standard 3/4" taper
- Hub included
- Meet with the EN 28848 and ABYC P22 standards

POLYURETHANE GRIP

- V10 - 41693 U black
- V11 - 41694 W white
- V12 - 41695 Y grey
- V13 - 41696 A ochre

POLISHED TEAK GRIP

- V14 - 41697 C
- V15 - 41698 E

STAINLESS STEEL GRIP

- V16 - 41699 G
- V17 - 41700 M



V10 Ø 13.8" (350 mm)



V11 Ø 13.8" (350 mm)



V12 Ø 13.8" (350 mm)



V13 Ø 13.8" (350 mm)



V14 Ø 13.8" (350 mm)
V15 Ø 15.7" (400 mm)



V16 Ø 13.8" (350 mm)
V17 Ø 15.7" (400 mm)

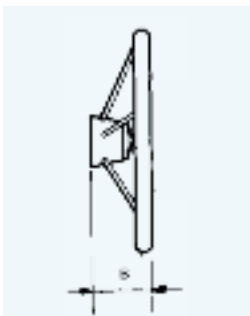

MOD.	B mm (")
V10	67 (2.6)
V11	67 (2.6)
V12	67 (2.6)
V13	67 (2.6)
V14	67 (2.6)
V15	73 (2.9)
V16	67 (2.6)
V17	73 (2.9)





NON MAGNETIC STAINLESS STEEL WHEELS

All ULTRAFLEX steering wheels meet the EEC directive 94/25 requirements about pleasure boats. All steering wheels are CE marked in conformity with the EN 28848 – EN 29775 and ABYC P22 safety standards

- Standard 3/4" taper
- Hub included
- Meet with the EN 28848 and ABYC P22 standards

STAINLESS STEEL GRIP

- V23 - 32397 D
- V35 - 31602 H
- V65 - 39436 J

POLYURETHANE GRIP

- V52B - 40631 P black
- V52W - 40633 U white
- V52G - 40632 S grey
- V57B - 38155 O black
- V57G - 38156 P grey



V35 Ø 13.6" (345 mm) - V23 Ø 15.7" (400 mm)



V65 Ø 14.5" (370 mm)



V52B Ø 12.6" (320 mm)



V52W Ø 12.6" (320 mm)



V52G Ø 12.6" (320 mm)



V57B Ø 13.8" (350 mm)



V57G Ø 13.8" (350 mm)

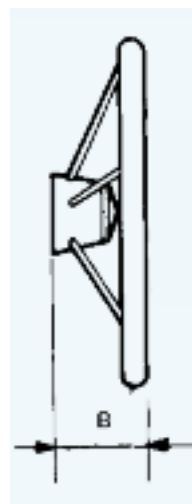

MOD.	B mm (")
V23	110 (4.3)
V35	100 (3.9)
V52	73 (2.9)
V57	76 (3.0)
V65	73 (2.9)



**NON
MAGNETIC
STAINLESS
STEEL
WHEELS**

All ULTRAFLEX steering wheels meet the EEC directive 94/25 requirements about pleasure boats. All steering wheels are CE marked in conformity with the EN 28848 - EN 29775 and ABYC P22 safety standards

- Standard 3/4" taper
- Hub included
- Meet with the EN 28848 and ABYC P22 standards

**EXCLUSIVE
POLYURETHANE
"FIRM GRIP"**

- V70B - 39442 D black
- V70W - 39929 J white
- V70G - 39441 B grey

POLYURETHANE GRIP

- V58B - 38649 X black
- V58G - 38650 F grey



V70B Ø 13.8" (350 mm)



V70W Ø 13.8" (350 mm)



V70G Ø 13.8" (350 mm)



V58B Ø 15.7" (400 mm)



V58G Ø 15.7" (400 mm)

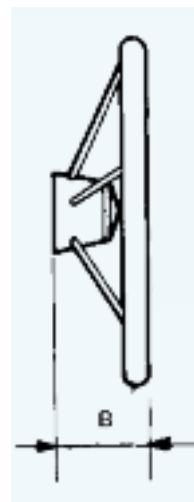

MOD.	B mm (")
V58	78 (3.0)
V70	90 (3.5)





YACHT STEERING WHEELS

All ULTRAFLEX steering wheels meet the EEC directive 94/25 requirements about pleasure boats. All steering wheels are CE marked in conformity with the EN 28848 – EN 29775 and ABYC P22 safety standards

- Standard 3/4" taper
- Hub included
- Meet with the EN 28848 and ABYC P22 standards

MAHOGANY GRIP

- V74 - 41115 A
- V75 - 41116 C
- V76 - 41117 E

NATURAL TEAK GRIP

- V77 - 41152 G
- V78 - 41153 J
- V79 - 41154 L

STAINLESS STEEL GRIP

- V221/16 - 42086 B
- Also available: 20", 24", 32", 36"

MAHOGANY GRIP

- V222/15 - 42087 D
- Also available: 20", 24", 28", 36", 47"

WOOD GRIP AND SPOKES

- V223/40 - 42088 F
- Also available: 47", 50"

TRADITIONAL WOOD WHEELS

- V224/12 - 42089 H
- Also available: 20", 25", 32"

- V225/18 - 42090 S
- Also available: 24", 28"



V74 Ø 15.7" (400 mm)
V75 Ø 17.7" (450 mm) - V76 Ø 19.6" (500 mm)



V77 Ø 15.7" (400 mm)
V78 Ø 17.7" (450 mm) - V79 Ø 19.6" (500 mm)



V221/16 – Ø 16.5" (420 mm)



V222/15 – Ø 15.7" (400 mm)



V223/40 – Ø 39.4" (1000 mm)



V223/40

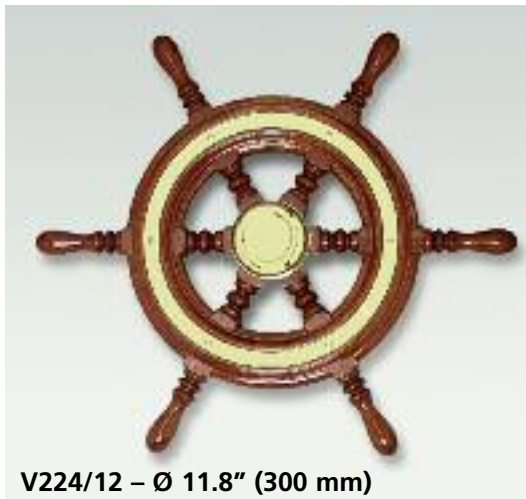

V224/12 – Ø 11.8" (300 mm)



V225/18 – Ø 18.1" (460 mm)

B mm (")
63 (2.5)
V71 ÷ V79





"VERO VOLANTE ITALIANO"

**IS THE REGISTERED
TRADEMARK
WHICH DISTINGUISHES
THE STEERING WHEELS
FOR PLEASURE BOATS
PRODUCED BY ULTRAFLEX**

VERO VOLANTE ITALIANO

STEERING WHEELS



BOCCANEGRA STEERING WHEELS

"VERO VOLANTE ITALIANO" is the registered trademark which distinguishes the steering wheels for pleasure boats produced by Ultraflex. They are conceived by Italian designers, engineered and manufactured in Italy by employing genuine Italian components and technologies according to Ultraflex quality management system.

- Standard 3/4" taper
- Hub included
- Meet with the EN 28848 and ABYC P22 standards

LEATHER GRIP AND HUB

BOCCANEGRA W - 67295 B
white

LEATHER GRIP PAINTED HUB

BOCCANEGRA SB - 67296 D
sky-blue



Boccanegra W - Ø 13.8" (350 mm)



Boccanegra SB - Ø 350 mm (13.8")

STEERING WHEELS



All ULTRAFLEX steering wheels meet the EEC directive 94/25 requirements about pleasure boats. All steering wheels are CE marked in conformity with the EN 28848 - EN 29775 and ABYC P22 safety standards



VERO VOLANTE ITALIANO

MOROSINI STEERING WHEELS

"VERO VOLANTE ITALIANO" is the registered trademark which distinguishes the steering wheels for pleasure boats produced by Ultraflex. They are conceived by Italian designers, engineered and manufactured in Italy by employing genuine Italian components and technologies according to Ultraflex quality management system.

- Standard 3/4" taper
- Hub included
- Meet with the EN 28848 and ABYC P22 standards

LEATHER GRIP AND HUB

MOROSINI SEA - 67301 T



Morosini Sea - Ø 13.8" (350 mm)



All ULTRAFLEX steering wheels meet the EEC directive 94/25 requirements about pleasure boats. All steering wheels are CE marked in conformity with the EN 28848 - EN 29775 and ABYC P22 safety standards



VERO VOLANTE ITALIANO





MOROSINI STEERING WHEELS

"VERO VOLANTE ITALIANO" is the registered trademark which distinguishes the steering wheels for pleasure boats produced by Ultraflex. They are conceived by Italian designers, engineered and manufactured in Italy by employing genuine Italian components and technologies according to Ultraflex quality management system.

- Standard 3/4" taper
- Hub included
- Meet with the EN 28848 and ABYC P22 standards

LEATHER GRIP, CHROME HUB

MOROSINI B/CH - 67297 F
MOROSINI G/CH - 67300 R

POLYURETHANE GRIP, CHROME HUB

MOROSINI PU B/CH - 67461 S



CHRISTIANGRANDE
DesignFloris



Morosini B/CH - Ø 350 mm (13.8")



Morosini G/CH - Ø 350 mm (13.8")

All ULTRAFLEX steering wheels meet the EEC directive 94/25 requirements about pleasure boats. All steering wheels are CE marked in conformity with the EN 28848 - EN 29775 and ABYC P22 safety standards



VERO VOLANTE ITALIANO

MOROSINI STEERING WHEELS

"VERO VOLANTE ITALIANO" is the registered trademark which distinguishes the steering wheels for pleasure boats produced by Ultraflex. They are conceived by Italian designers, engineered and manufactured in Italy by employing genuine Italian components and technologies according to Ultraflex quality management system.

- Standard 3/4" taper
- Hub included
- Meet with the EN 28848 and ABYC P22 standards

LEATHER GRIP, PAINTED HUB

MOROSINI W - 67298 H
MOROSINI C - 67299 K



CHRISTIANGRANDE
DesignWorks



Morosini W - Ø 350 mm (13.8")



Morosini C - Ø 350 mm (13.8")



All ULTRAFLEX steering wheels meet the EEC directive 94/25 requirements about pleasure boats. All steering wheels are CE marked in conformity with the EN 28848 – EN 29775 and ABYC P22 safety standards



VERO VOLANTE ITALIANO



FOSCARI STEERING WHEELS

"VERO VOLANTE ITALIANO" is the registered trademark which distinguishes the steering wheels for pleasure boats produced by Ultraflex. They are conceived by Italian designers, engineered and manufactured in Italy by employing genuine Italian components and technologies according to Ultraflex quality management system.

- Standard 3/4" taper
- Hub included
- Meet with the EN 28848 and ABYC P22 standards

POLYURETHANE GRIP

FOSCARI B - 67303 X
 FOSCARI W - 67302 V
 FOSCARI C - 67304 Z

SKY GRIP

FOSCARI L - 67305 B

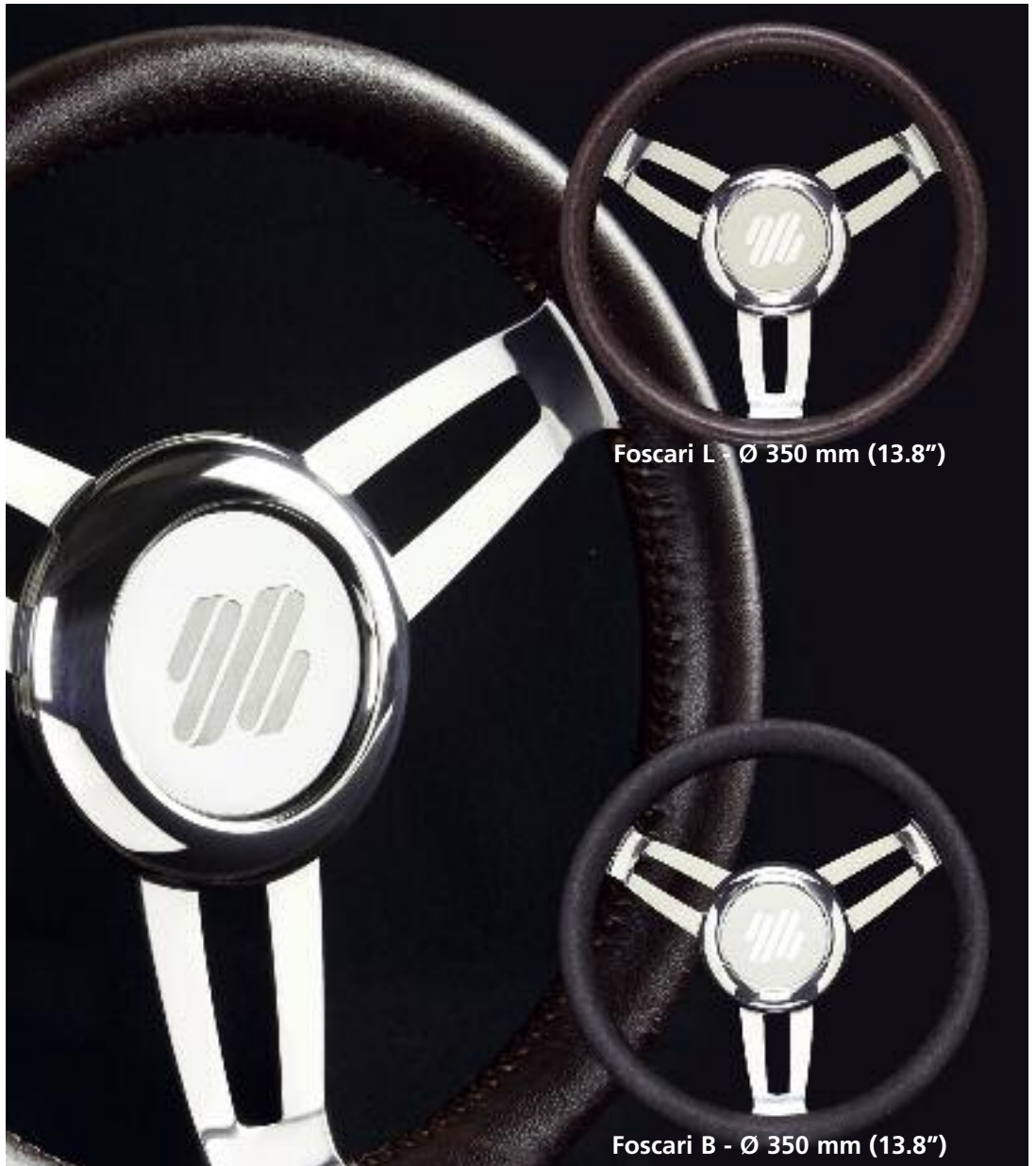

Foscari L - Ø 350 mm (13.8")

Foscari B - Ø 350 mm (13.8")



Foscari W - Ø 350 mm (13.8")



Foscari C - Ø 350 mm (13.8")

All ULTRAFLEX steering wheels meet the EEC directive 94/25 requirements about pleasure boats. All steering wheels are CE marked in conformity with the EN 28848 - EN 29775 and ABYC P22 safety standards



VERO VOLANTE ITALIANO

DORIA STEERING WHEEL

"VERO VOLANTE ITALIANO" is the registered trademark which distinguishes the steering wheels for pleasure boats produced by Ultraflex. They are conceived by Italian designers, engineered and manufactured in Italy by employing genuine Italian components and technologies according to Ultraflex quality management system.

- Standard 3/4" taper
- Hub included
- Meet with the EN 28848 and ABYC P22 standards

POLYURETHANE GRIP WITH INSERTS

DORIA B/R - 67309 K
DORIA C/W - 67479 M

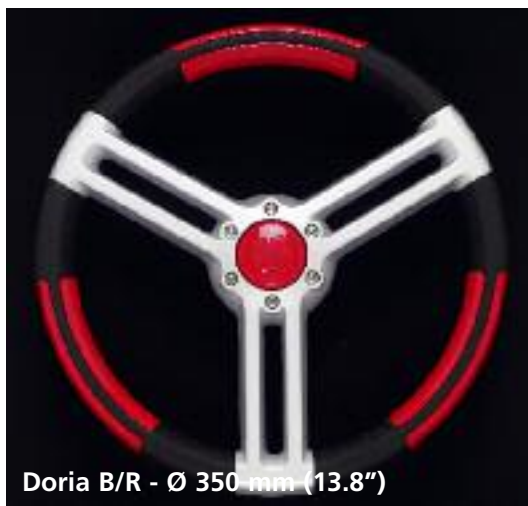

Doria B/R - Ø 350 mm (13.8")



Doria C/W - Ø 350 mm (13.8")



All ULTRAFLEX steering wheels meet the EEC directive 94/25 requirements about pleasure boats. All steering wheels are CE marked in conformity with the EN 28848 – EN 29775 and ABYC P22 safety standards



VERO VOLANTE ITALIANO





DORIA STEERING WHEEL

"VERO VOLANTE ITALIANO" is the registered trademark which distinguishes the steering wheels for pleasure boats produced by Ultraflex. They are conceived by Italian designers, engineered and manufactured in Italy by employing genuine Italian components and technologies according to Ultraflex quality management system.

- Standard 3/4" taper
- Hub included
- Meet with the EN 28848 and ABYC P22 standards

POLYURETHANE GRIP WITH INSERTS

DORIA B/B - 67465 A
DORIA W/W - 67728 G



Doria B/B - Ø 350 mm (13.8")



Doria W/W - Ø 350 mm (13.8")

All ULTRAFLEX steering wheels meet the EEC directive 94/25 requirements about pleasure boats. All steering wheels are CE marked in conformity with the EN 28848 - EN 29775 and ABYC P22 safety standards



VERO VOLANTE ITALIANO



95

MECHANICAL CONTROL SYSTEMS



SINGLE LEVER SIDE MOUNT CONTROLS

Featuring AISI 316 stainless steel lever and bezel, the B400 has a sleek and modern design which is ideal for sailboats. The B400 has universal control mechanism that allows for both "push" or "pull" for throttle and shift, push button warm up, and will accept 33C style cables, as well as BRP®, Mercury® Gen I and Gen II cables with optional adapters. Available in mechanical version or hybrid version (patented) to control the shift by a mechanical cable and the throttle via 0-5V electric signal.

FEATURES

- 316 stainless steel lever and flange for a better resistance in the marine environment
- Enables easy and safe shifting by preventing accidental gear engagement unless engine is idling
- Can be installed horizontally or vertically, on the starboard or port side of the boat
- Provided with a brake tension release system easily adjustable
- Push-in button for throttle operation in Neutral (ENGINE WARM UP).
- Neutral safety switch **X41** - 38130 F included prevents in-gear starting
- Exceeds EN ISO 11547 standards when **X41** safety switch is installed
- The **B401-ETC hybrid version** (patented) can control the shift with a mechanical cable and the throttle via 0-5V electric signal. The output signal can be set by the installer; the setting can be simply operated through dipswitches placed under the control box.
- For use with all Ultraflex engine control cables except C22:
 - Ultraflex C2, C8, MACHZero cables require no kit
 - Ultraflex C14, MACH14 cables require **K71** - 42082 T connection kit
 - Ultraflex C5, C16. MACH5 cables require **K72** - 42083 V connection kit
 - Ultraflex C36, MACH36 cables require **K73** - 42084 X connection kit



B400

B401-ETC



MODELS

B400 - 42076 Y Fully mechanical version

B401-ETC - 42077 A Hybrid version

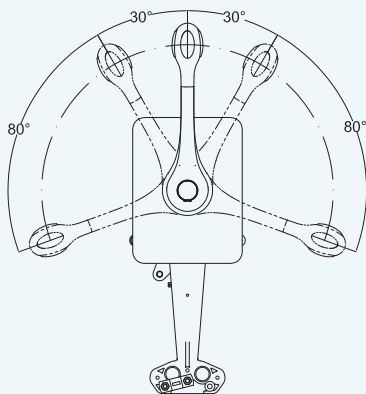

B400 - B401-ETC

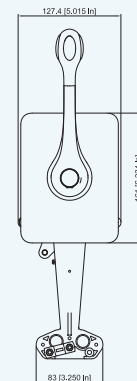
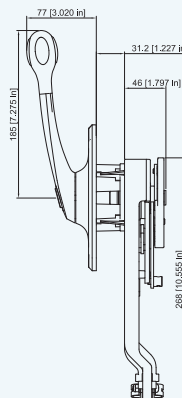

SINGLE LEVER SIDE MOUNT CONTROLS

The new B310 controls combine elegance, functionality and versatility. Available with chrome, burl or soft touch control levers, the B310 series can be used on outboards, sterndrives and inboard applications. The universal control design allows for the connection of 33C Universal style cable and OMC (Johnson/Evinrude) cables with adapters included. Mercury Gen I cables can be easily connected with the addition of the K35 connection kit.

FEATURES

- Enables easy and safe shifting by preventing accidental gear engagement unless engine is idling
- Can be installed horizontally or vertically, on the starboard or port side of the boat
- Provided with a brake tension release system adjustable from outside
- Pull-out handle disengages shift for warm-up
- Includes X50 neutral safety switch which prevents in-gear starting
- Exceeds EN ISO 11547 standards when X50 safety switch is installed
- All models are provided with positive lock-in neutral to prevent accidental gear engagement
- All models are provided with a power trim switch conveniently located in the handle grip that enables an easy tilting of the engine
- For use with:
 - All Ultraflex control cables except C4, C36 and MACH36
 - Mercury® \ current BRP® (OMC®) \ Yamaha® \ Suzuki® \ Honda® \ Volvo® style cables
 - 33C style cables
- Ultraflex C5, C16, MACH5 and Mercury® cables require K35 - 34730 U connection kit
- Ultraflex C22 and C23 cables require KB1 - 39964 L connection kit

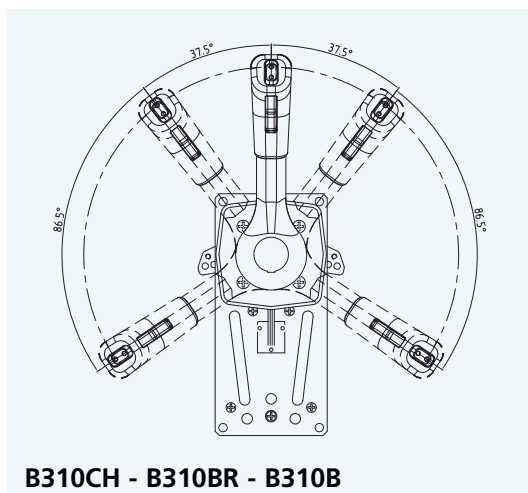

MODELS

B310CH - 41789 H
Provided with a positive lock-in neutral and trim switch

B310BR - 41788 F
Provided with a positive lock-in neutral and trim switch

B310B - 41790 S
Provided with a positive lock-in neutral and trim switch

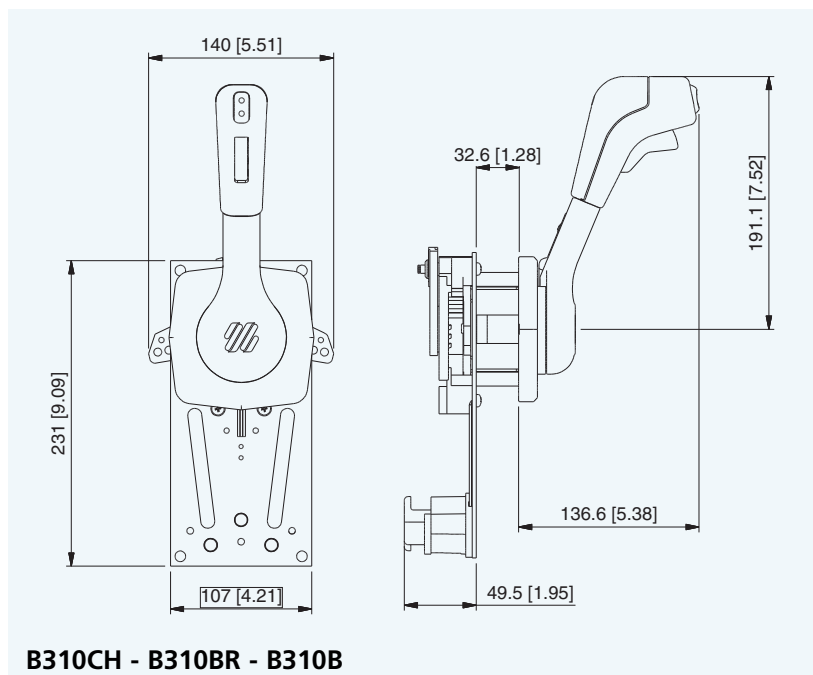



SINGLE LEVER SIDE MOUNT CONTROLS

Single lever / dual action control to operate both throttle and shift.
Suitable for any type of boats with outboard, inboard or I/O power plants.

FEATURES

- Enables easy and safe shifting by preventing accidental gear engagement unless engine is idling
- Can be installed horizontally or vertically, on the starboard or port side of the boat
- Provided with a brake tension release system adjustable from outside
- Pull-out handle disengages shift for warm-up
- Includes X12 neutral safety switch which prevents in-gear starting
- Exceeds EN ISO 11547 standards when X12 safety switch is installed
- All models are provided with positive lock-in neutral to prevent accidental gear engagement
- B184 and B184CB models are provided with a power trim switch conveniently located in the handle grip that enables an easy tilting of the engine
- For use with:
 - All Ultraflex control cables except C4, C36 and MACH36
 - Mercury® \ current BRP® (OMC®) \ Yamaha® \ Suzuki® \ Honda® \ Volvo® style cables
 - 33C style cables
- Ultraflex C5, C16, MACH5 and Mercury® cables require **K35 - 34730 U** connection kit
- Ultraflex C22 and C23 cables require **KB1 - 39964 L** connection kit



B183



B184



B85



MODELS

B183 - 38945 B
Provided with a positive lock-in neutral

B184 - 38946 D
Provided with a positive lock-in neutral and trim switch

B85 - 35682 I
Standard model, smooth design for use on sailboats. Provided with a positive lock-in neutral

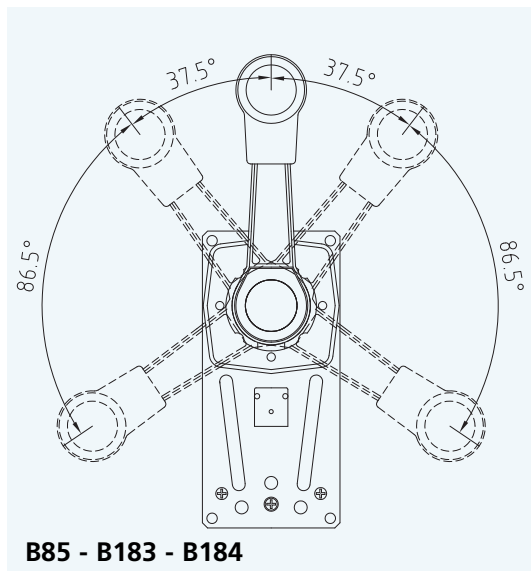

B85 - B183 - B184

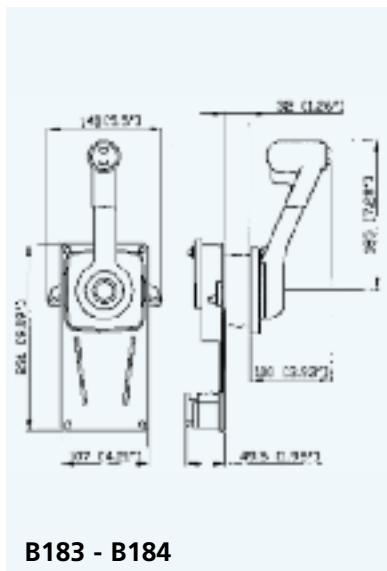

B183 - B184

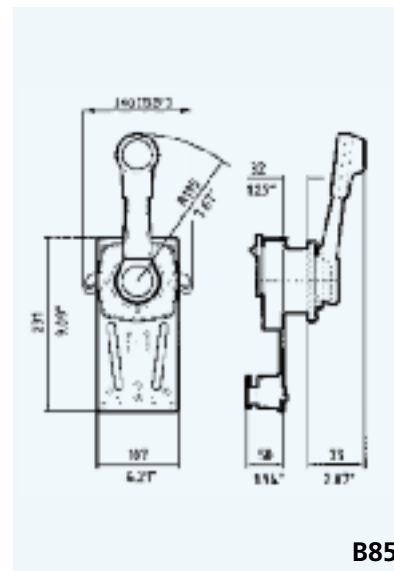

B85

SINGLE LEVER SIDE MOUNT CONTROLS

Single lever / dual action control to operate both throttle and shift.
Suitable for any type of boats with outboard, inboard or I/O power plants.

FEATURES

- Enables easy and safe shifting by preventing accidental gear engagement unless engine is idling
- Can be installed horizontally or vertically, on the starboard or port side of the boat
- Made of painted marine aluminum
- Pull-out handle disengages shift for warm-up
- Includes X12 neutral safety switch which prevents in-gear starting
- Exceeds EN ISO 11547 standards when X12 safety switch is installed
- Provided with a positive lock-in neutral to prevent accidental gear engagement
- For use with:
 - All Ultraflex control cables except C22, C4, C36 and MACH36
 - Mercury® \ current BRP® (OMC®) \ Yamaha® \ Suzuki® Honda® \ Volvo® style cables
 - 33C style cables
- Ultraflex C5, C16, MACH5 and Mercury® cables require **K35** - 34730 U connection kit.
- To connect C14 and MACH14 cables and current BRP® (OMC®) cable to engine, use **K51** - 32526 N connection kit.

MODELS

B89 - 36151 G
Ivory finish with positive lock-in neutral.

B90 - 36152 H
Black finish with positive lock-in neutral.



B89

B90



Lock-in neutral

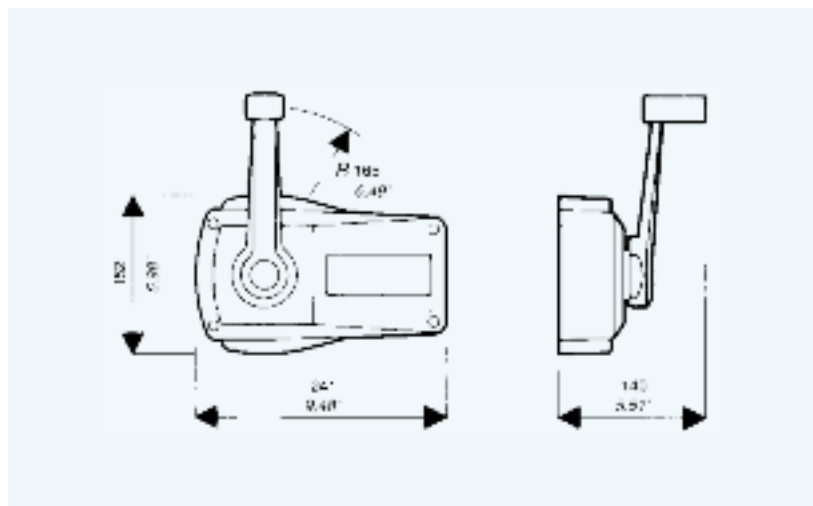

"LOW PROFILE" SINGLE LEVER TOP MOUNT CONTROLS

Combining traditional styling with a low profile design, the B301 and B302 controls provide the look and feel of electronic controls without the cost. With a focus on efficiency these controls have been specifically designed to improve the functionality of older control systems, making the boat easier to control.

When coupled with the Mach series control cables with industry leading efficiency, this series of controls will provide nearly fingertip control of the control system.

Single lever / dual action control to operate both with throttle and shift.
Suitable for any type of boats with outboard, inboard or I/O power plants.

FEATURES

- Compact single lever controls offering a unique low profile style compared to other controls available on the market
- Enables easy and safe shifting by preventing accidental gear engagement unless engine is idling
- Made of marine aluminum, chrome plated or powder coat finish
- Push in button disengages shift for warm-up
- Includes X12 neutral safety switch which prevents in-gear starting
- Exceeds EN ISO 11547 standards when X12 safety switch is installed
- For use with all Ultraflex control cables except C4:
 - C14 and MACH14 cables require no kit
 - for C2, C8 and MACHZero cables the connection kit K59 - 40144 C is included
 - C5, C16 and MACH5 cables require K60 Kit - 40145 E
 - C36 and MACH36 cables require K62 Kit - 40157 J
 - C22 cable requires K61 Kit - 40146 G

MODELS

B301CR - 40140 U
Single lever control for one engine, chrome plated.

B302CR - 40141 W
Twin lever control for two engines, chrome plated.

X75 - 40662 B
Silver knob **optional**



B301CR

B302CR



2 X75 (OPTIONAL)



B302CR + 2 X75

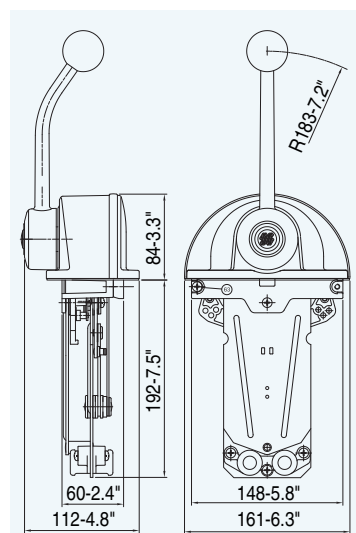

B301

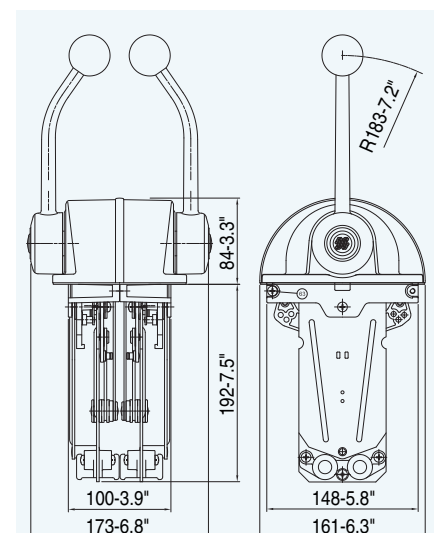

B302

"LOW PROFILE" SINGLE LEVER TOP MOUNT CONTROLS

Single lever / dual action control to operate both with throttle and shift.
Suitable for any type of boats with outboard, inboard or I/O power plants.

FEATURES

- Compact single lever controls offering a unique low profile style compared to other controls available on the market
- Enables easy and safe shifting by preventing accidental gear engagement unless engine is idling
- Made of marine aluminum, chrome plated or powder coat finish
- Push in button disengages shift for warm-up
- Includes X12 neutral safety switch which prevents in-gear starting
- Exceeds EN ISO 11547 standards when X12 safety switch is installed
- For use with all Ultraflex control cables except C4:
 - C14 and MACH14 cables require no kit
 - for C2, C8 and MACHZero cables the connection kit is **K59** - 40144 C included
 - C5, C16 and MACH5 cables require **K60** Kit - 40145 E
 - C36 and MACH36 cables require **K62** Kit - 40157 J
 - C22 cable requires **K61** Kit - 40146 G

MODELS

B301B - 40142 Y

Single lever control for one engine, black dome, chrome plated lever.

B302B - 40143 A

Twin lever control for two engines, black dome, chrome plated lever.

X75 - 40662 B

Silver knob **optional**



B301B

B302B



2 X75 (OPTIONAL)



B302B + 2 X75

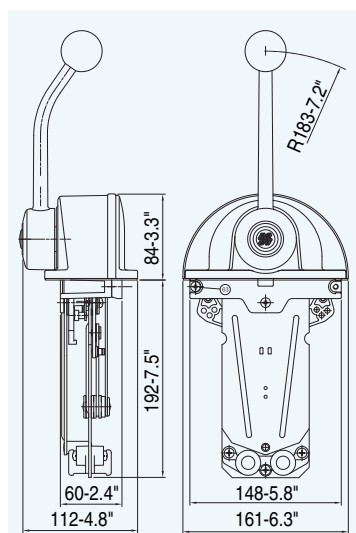

B301

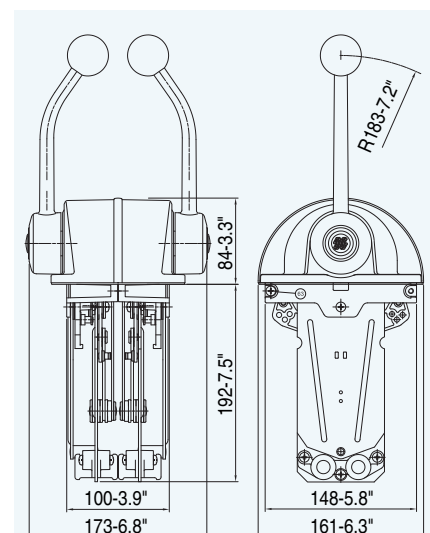

B302



SINGLE LEVER TOP MOUNT CONTROLS

Single lever / dual action control to operate both throttle and shift.
Suitable for any type of boats with outboard, inboard or I/O power plants.

FEATURES

- Enables easy and safe shifting by preventing accidental gear engagement unless engine is idling
- Made of chrome plated marine aluminium
- Pull-out handle disengages shift for warm-up
- Neutral safety switch **X43** - 38160 L included prevents in-gear starting
- Exceeds EN ISO 11547 standards when X43 safety switch is installed
- Built-in friction to avoid throttle creep
- For use with Ultraflex C2, C8, MACHZero and all 33C style engine control cables
- To connect Ultraflex C22 and 43C style cables to B103 control box only, use **K33** - 38378 D connection kit

MODELS

- B103** - 37923 K
Single lever control for one engine
- B104** - 37924 L
Twin lever control for two engines
- B103S** - 39354 G
Single lever control for one engine - Silver knob
- B104S** - 39355 J
Twin lever control for two engines - Silver knobs

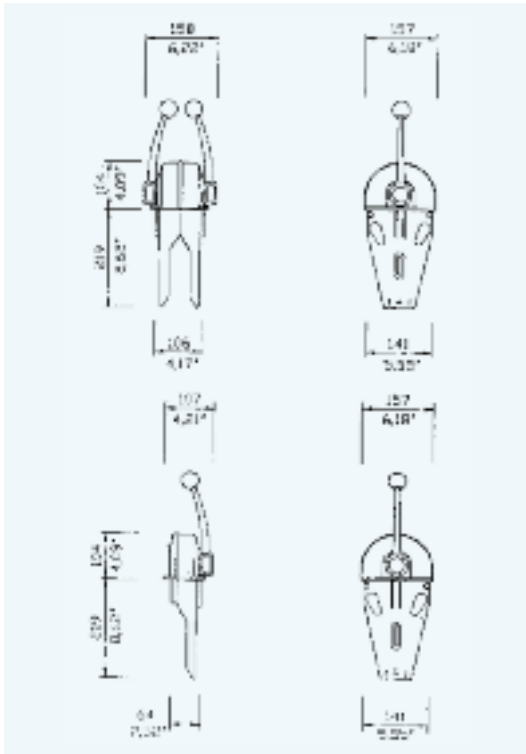

B103

B104



B104S

SINGLE LEVER TOP MOUNT CONTROLS

Single lever / dual action control to operate both throttle and shift.
Suitable for any type of boats with outboard, inboard or I/O power plants.

FEATURES

- Enables easy and safe shifting by preventing accidental gear engagement unless engine is idling
- Made of marine aluminum, chrome plated or powder coat finish
- Pull-out handle disengages shift for warm-up
- Includes X12 neutral safety switch which prevents in-gear starting
- Exceeds EN ISO 11547 standards when X12 safety switch is installed
- Power trim switch conveniently located in the handle grip enables for easy tilting of the engine
- For use with all Ultraflex engine control cables except C22, C4, C36 and MACH36.
- Ultraflex C5, C16 and MACH5 cables require K35 kit - 34730 U

MODELS

B65 - 34731 V

Single lever control for one engine, chrome plated.

B76 - 35312 E

Single lever control for one engine, chrome plated, with trim.

B66 - 34732 W

Twin lever control for two engines, chrome plated.

B78 - 35314 G

Twin lever control for two engines, chrome plated, with trim.

B73 - 35007 U

Single lever control for one engine, black dome, chrome plated lever.

B77 - 35313 F

Single lever control for one engine, black dome, chrome plated lever, with trim.

B74 - 35008 B

Twin lever control for two engines, black dome, chrome plated lever.

B79 - 35315 H

Twin lever control for two engines, black dome, chrome plated lever, with trim.

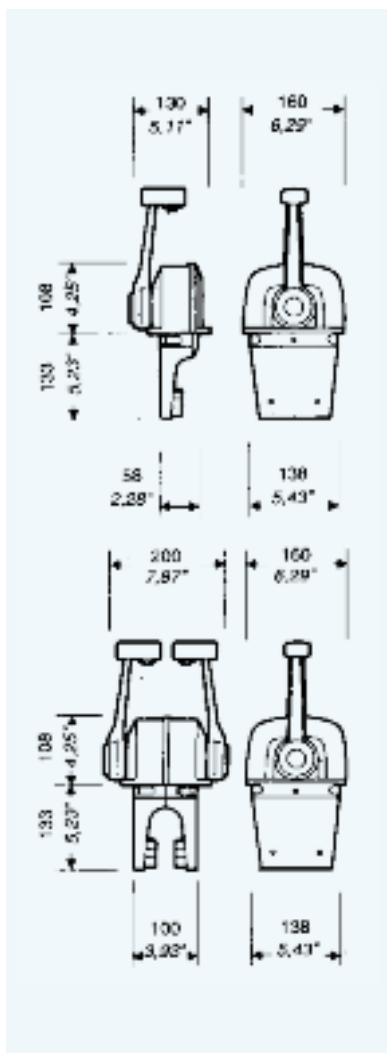
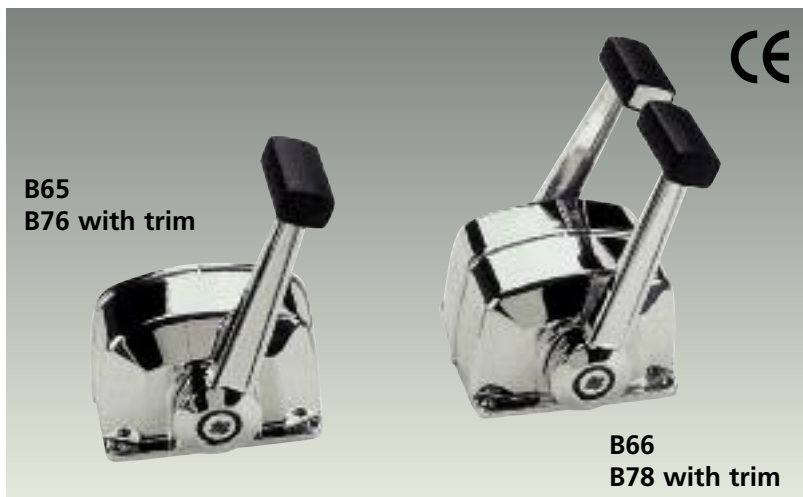



TWO LEVER TOP MOUNT CONTROLS

Two lever / single action control: each lever operates separately either the throttle or shift. Suitable for use with outboard, inboard or I/O power plants.

FEATURES

- Flush mount suitable for exposed positions such as flying bridge
- Made of marine aluminium with chrome plated lever
- Throttle lever is provided with adjustable brake tension release system and shift lever with forward, reverse and neutral detents. Both the brake tension release and detents can be installed and adjusted from the outside.
- Neutral safety switch **X12** - 34543 Q included prevents in-gear starting
- Exceeds EN ISO 11547 standards when X12 safety switch is installed
- Available with straight or bent levers
- B58 and B59 models are provided with an interlock kit to prevent accidental gear engagement
- For use with Ultraflex C2, C8, MACHZero and all 33C style engine control cables.
- Ultraflex C22 and all 43C style cables require **K22** - 34713 Q connection kit.
- Burl wood cover **optional**:
X51 - 38985 P

MODELS

BENT LEVERS:

- B46** - 34461 P Throttle and shift
- B46T** - 34462 Q Throttle only
- B46S** - 34463 R Shift only
- B58R** - 34570 W Throttle and shift. With interlock. Right hand installation
- B58L** - 34716 T Throttle and shift. With interlock. Left hand installation

STRAIGHT LEVERS:

- B50** - 34464 S Throttle and shift
- B50T** - 34465 T Throttle only
- B50S** - 34466 U Shift only
- B59R** - 34571 X Throttle and shift. With interlock. Right hand installation
- B59L** - 34717 U Throttle and shift. With interlock. Left hand installation

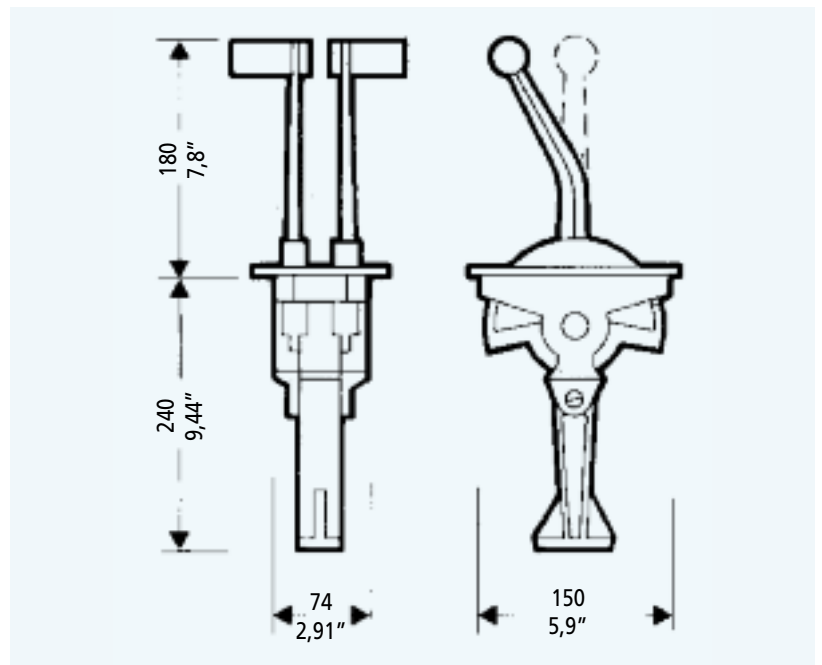

TWO LEVER TOP MOUNT CONTROLS

Two lever / single action control: each lever operates separately either the throttle or shift. Suitable for use with outboard, inboard or I/O power plants.

FEATURES

- Flush mount suitable for exposed positions such as flying bridge
- Levers structure made of die cast zinc provided with a soft thermoplastic ergonomical handgrip
- Adjustable brake to avoid throttle creep and positive detent for shift
- Adjustable ratchet for precise throttle operation obtained applying to the gas lever the optional kit **K52** - 37382 B
- Neutral safety switch **X12** - 34543 Q included prevents in-gear starting
- Exceeds EN ISO 11547 standards when X12 safety switch is installed
- Raked throttle handle and straight gear handle for a better manoeuvring
- B204 and B208 models are provided with an interlock kit to prevent accidental gear engagement
- For use with Ultraflex C2, C8, MACHZero and all 33C style engine control cables.
- Ultraflex C22 and all 43C style cables require **K22** - 34713 Q connection kit.
- Burl wood cover **optional**:
X51 - 38985 P

MODELS

Black painted control with black soft hand grip:

B203T - 37380 Z Throttle only

B203S - 37381 A Shift only

White painted control with grey soft hand grip:

B207T - 37652 A Throttle only

B207S - 37653 B Shift only



B207
B208 with interlock



X51
Burl wood cover

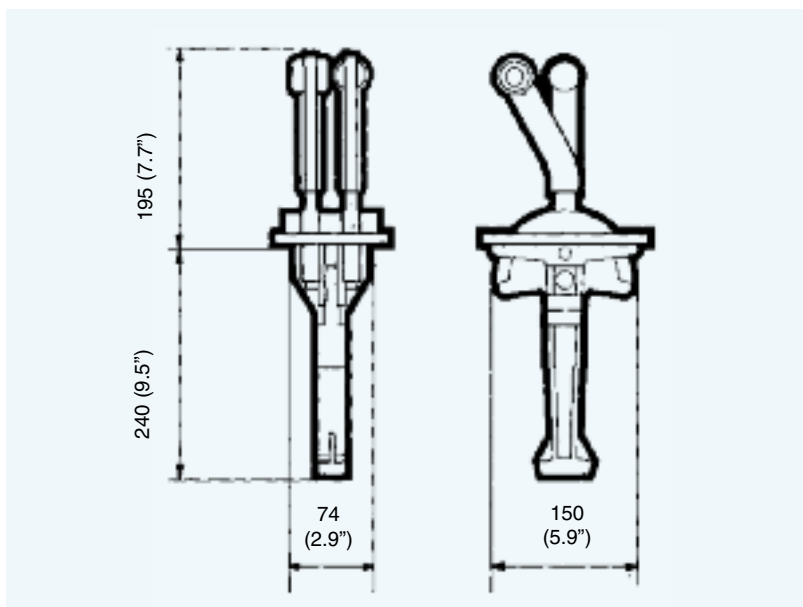



TWO LEVER TOP MOUNT CONTROLS



106

Two lever / single action control: each lever operates separately either the throttle or the shift.

Suitable for use with outboard, inboard or I/O power plants.

FEATURES

- Made of aluminium, chrome plated or black powder coat finish
- Throttle lever is provided with adjustable brake tension release system and shift lever with forward, reverse and neutral detents.
- Includes X12 neutral safety switch which prevents in-gear starting
- In dual station applications the L23-31649 B selector unit has to be used (page 110)
- Exceeds EN ISO 11547 standards when X12 safety switch is installed
- Use with all Ultraflex control cables except C4:
 - C14 and MACH14 cables require no kit
 - For C2, C8 and MACHZero cables the connection kit K67 - 40705 T is included
 - C5, C16 and MACH5 cables require K63 kit - 40757 N
 - C22 cable requires K64 kit - 40758 R
 - C36 and MACH36 cables require K65 kit - 40759 T

MODELS

CHROME PLATED:

B322 - 40669 S Throttle and shift

B322T - 40670 A Throttle only

B322S - 40673 G Shift only

BLACK FINISH:

B324 - 40674 J Throttle and shift

B324T - 40675 L Throttle only

B324S - 40676 N Shift only



B322

B324

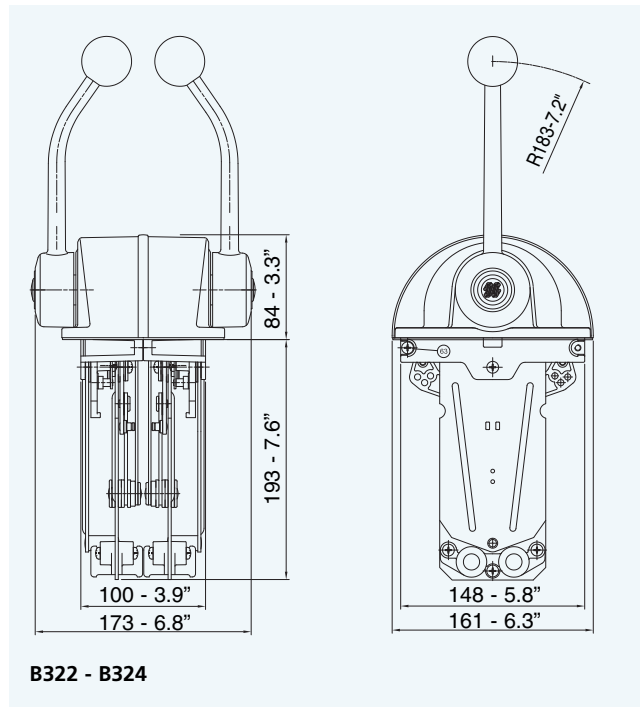

B322 - B324

TWO LEVER TOP MOUNT CONTROLS

Two lever / single action control: each lever operates separately either the throttle or shift. Suitable for use with outboard, inboard or I/O power plants.

FEATURES

- All versions are provided with shift lever detents and with a brake tension release system adjustable from the outside of the throttle lever
- Neutral safety switch X12 - 34543 Q included prevents in-gear starting
- Exceeds EN ISO 11547 standards when X12 safety switch is installed
- Suitable for exposed positions such as flying bridge
- For use with Ultraflex C2, C8, MACHZero and all 33C style engine control cables
- Ultraflex C22 and all 43C style cables require K32 - 34662 Z connection kit

MODELS

- B101** - 36856 P Throttle and shift. White painted.
B101T - 36942 M Throttle only. White painted.
B101S - 36898 F Shift only. White painted.
B102 - 36899 G Throttle and shift. Black painted.
B102T - 36992 A Throttle only. Black painted.
B102S - 36900 C Shift only. Black painted.

- X54** - 39340 V Silver knob for B101-B102.



B101

B102



B101 with X54
Silver knobs

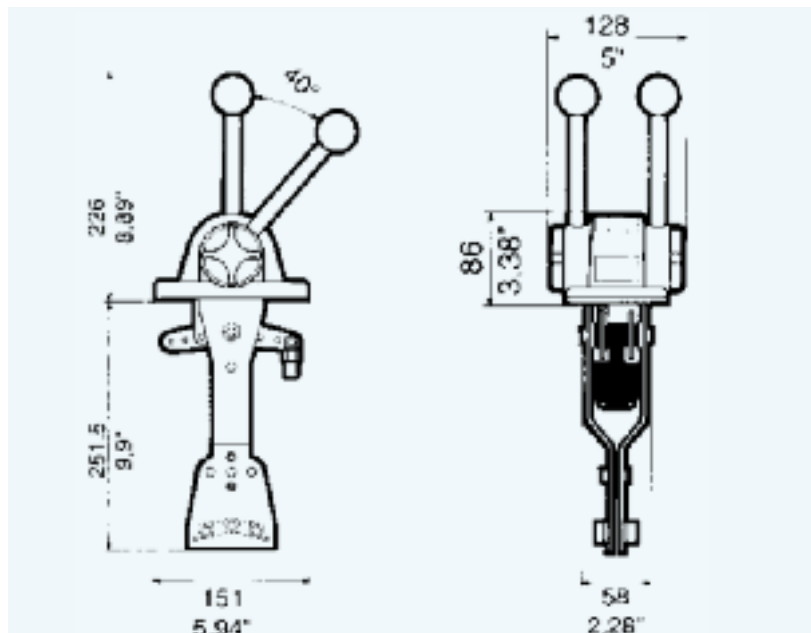

ACCESSORIES FOR CONTROL BOXES

K22 - 34713 Q

Kit to connect C22 and 4300 series cables to top mount two lever control boxes, B46, B50, B58, B59, B203, B204, B207, B208, B322, B324

K23 - 32773 D

Kit to connect C14, MACH14 and BRP® (OMC®) type "OS" cables to B47 and B49 control boxes.

K24 - 32774 E

Kit to connect C4 and BRP® (OMC®) type "O" cables to B47 and B49 control boxes.

K25 - 32775 F

Kit to connect C2, C8, MACHZero and all 33C style cables to B47 and B49 control boxes.

K32 - 34662 Z

Kit to connect C22 and 4300 series cables to top mount two lever control boxes B101 and B102.

K33 - 38378 D

Kit to connect C22 and 4300 series cables to B103 control box.

KB1 - 39964 L

Kit to connect C22 and 4300 series cables to B183, B184 and B184CB control boxes.

K35 - 34730 U

Kit to connect C5, C16, MACH5 and Mercury® style cables to single lever control boxes, except B301, B302, B103 and B104.

K51 - 32526 N

Kit to connect C14, MACH14 and OMC® type "OS" cables to engine for use with B89 and B90.

K59 - 40144 C

Kit to connect C2, C8 and MACHZero cables to B301 and B302 controls (supplied with the box).

K60 - 40145 E

Kit to connect C5, C16, MACH5 and Mercury® (except Gen II™) cables to B301 and B302 control boxes.

K61 - 40146 G

Kit to connect C22 and 4300 series cables to B301 and B302 control boxes.

K62 - 40147 J

Kit to connect C36, MACH36 and Mercury® Gen II™ cables to B301 and B302 control boxes.

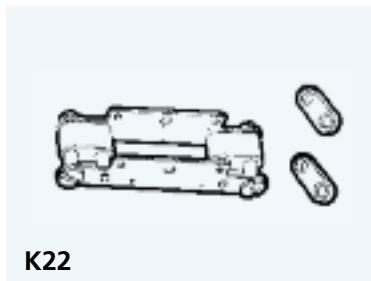

K22

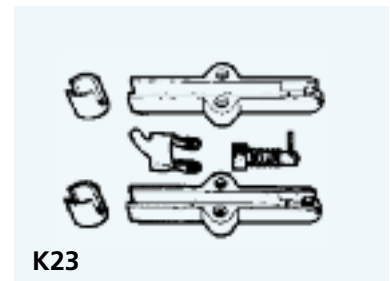

K23

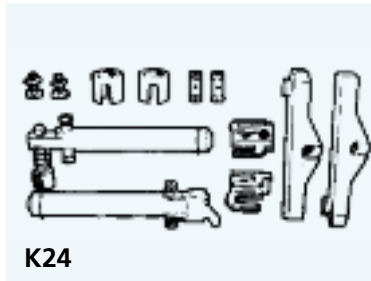

K24



K25

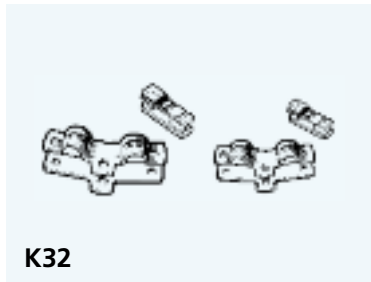

K32

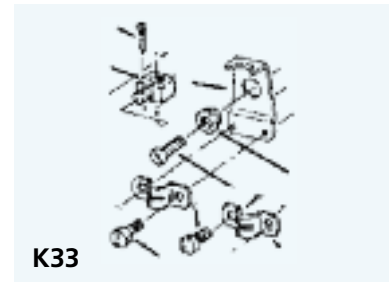

K33

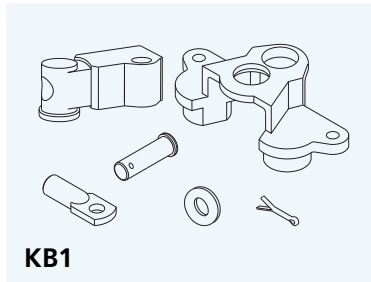

KB1



K35

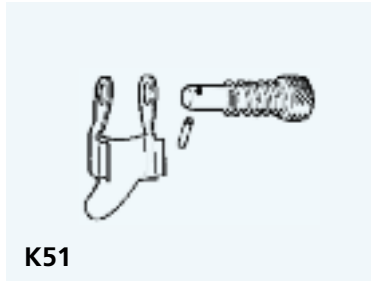

K51

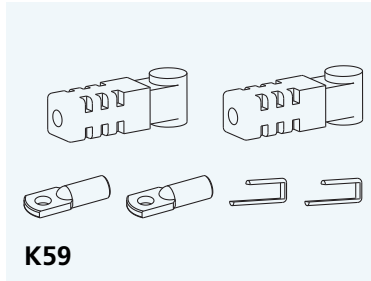

K59

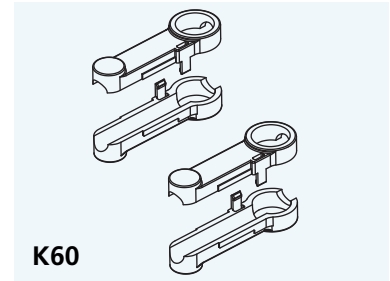

K60

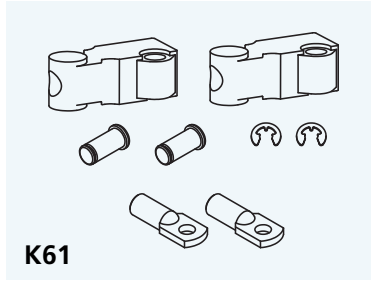

K61

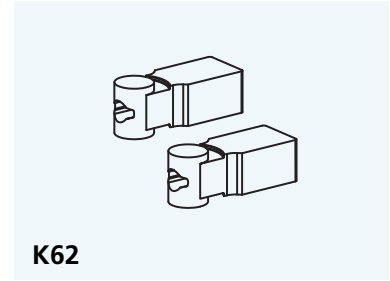

K62



ACCESSORIES FOR CONTROL BOXES

110

K63 - 40757 N

Kit to connect C5, C16, MACH5 cables to B322 and B324 controls.

K64 - 40758 R

Kit to connect C22 cable to B322 and B324 controls.

K65 - 40759 T

Kit to connect C36 and MACH36 cables to B322 and B324 controls.

K67 - 40705 T

Kit to connect C2, C8 and MACHZero cables to B322 and B324 controls (supplied with the box)

K71 - 42082 T

Kit to connect C14 and MACH14 to B400 and B401-ETC controls

K72 - 42083 V

Kit to connect C5, C16 and MACH5 to B400 and B401-ETC controls

X12 - 34543 Q

Neutral safety switch to prevent in-gear starting.

X41 - 38130 F

Neutral safety switch to prevent in-gear starting, suitable for B400 and B401-ETC controls.

X43 - 38160 L

Neutral safety switch to prevent in-gear starting, suitable for B103 and B104 controls.

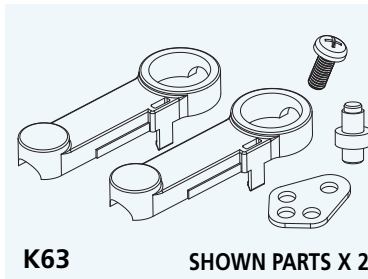

K63

SHOWN PARTS X 2

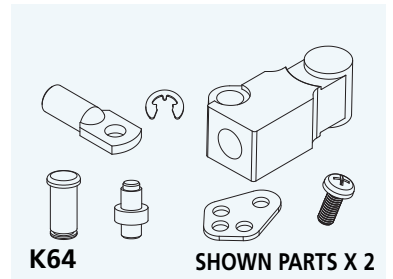

K64

SHOWN PARTS X 2

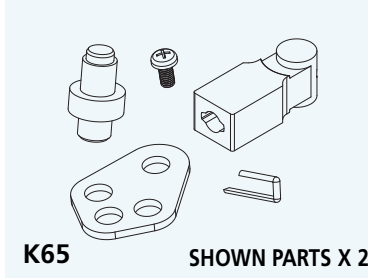

K65

SHOWN PARTS X 2

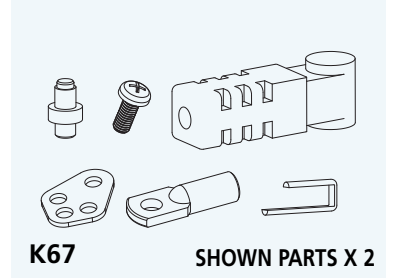

K67

SHOWN PARTS X 2

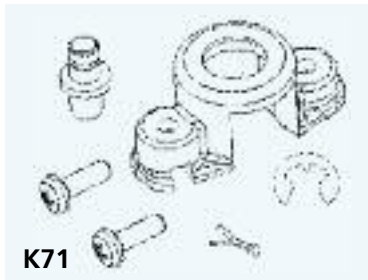

K71

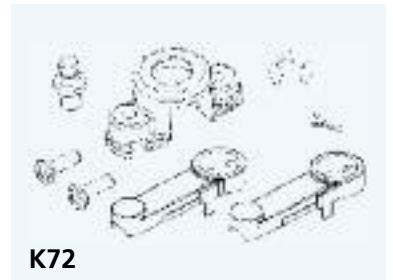

K72

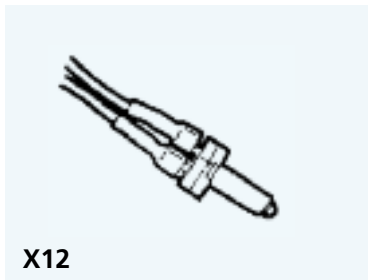

X12

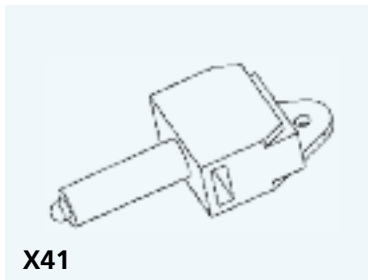

X41

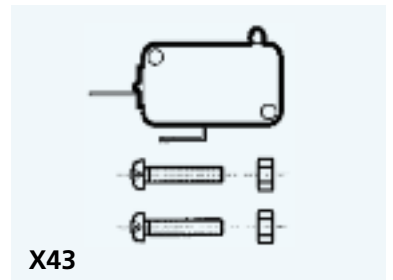

X43



HOW TO MEASURE FOR CONTROL CABLE INSTALLATION

FOR NEW INSTALLATION, measure A + B distance from the control along an unobstructed cable routing to clutch and / or throttle connection. Round this dimension off to the next whole foot: you will have your cable length. We recommend that the cable bends have a minimum radius of about 8" (200 mm). For outboard engine installations, it is necessary to add three feet to the obtained length, in order to allow the engine movement.

To determine the needed length of the REPLACEMENT CABLE, measure it from tip to tip. When ordering, specify the cable length in feet, rounding the dimension off to the next whole value. If any kit is required to complete the cable connection, consult the appropriate section in this catalog.

OUTBOARD

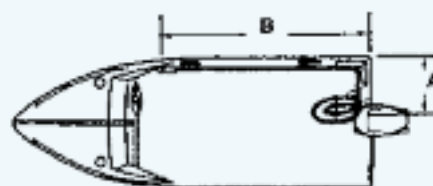

$$A + B + 3' (90 \text{ cm}) = L$$

INBOARD/STERNDRIVE



$$A + B = L$$

CONTROL CABLE CROSS REFERENCE

ULTRAFLEX	TELEFLEX® PART#	MORSE® PART#	APPLICATION
C2	UNIVERSAL CABLE CC172		YAMAHA®, SUZUKI®, HONDA®, NISSAN®, TOHATSU®, SELVA®
C8	MIRACABLE™ CC330 PREMIUM™ CC199	33C RED JACKET™ 32377-003	YAMAHA®, SUZUKI®, HONDA®, NISSAN®, TOHATSU®, SELVA®
MACHZero™	TFXTREME™ CC223	33C SUPREME™ 301947-003	YAMAHA® over 60 hp, SUZUKI®, HONDA®, NISSAN®, TOHATSU®, SELVA®
C5 - MACH5™	600A CC179	TYPE KM 637323	MERCURY®, MERCRIUSER®, MARINER® OVER 50 hp
C4	400 TYPE CC170	TYPE O 48296	PRE 1979 OMC®, EVINRUDE®, JOHNSON®
C14 - MACH14™	479 TYPE CC205	TYPE OS 302029	1979 TO DATE OMC®, JOHNSON®, EVINRUDE®, BRP®
C16	630 TYPE CC210		MARINER® UP TO 50 hp
C25	CC214	TYPE OC 310048	VOLVO® WITH OMC® CONTROLS
C22	STANDARD 4300 TYPE CC193	43C REDLINE 65835-003	HEAVY DUTY APPLICATIONS INBOARDS AND JETS
C23 BC	BULKHEAD 4300 TYPE CC192	43BC REDLINE 46348-003	HEAVY DUTY APPLICATIONS INBOARDS AND JETS
C36 - MACH36™			MERCURY® GENERATION II™ CONTROLS



MACH™ SERIES
HIGH EFFICIENCY
AND FLEXIBILITY
ENGINE CONTROL CABLES

For the ultimate in efficiency and response, the Mach Series cables deliver unmatched results. They have been specifically designed to make even the most complex of cable installations result in smooth, easy and precise shift and throttle movement. Using a patented stranded wire core with lubricated extrusion, the Mach cables are an ideal solution for applications with long cable runs, tight bends, or where easy and precise throttle response is required. Mach Series cables also feature solid stainless steel output fittings and are available in 33C, Mercury® Gen I, Mercury® Gen II and BRP® styles.

- The "high performance" *MACH™* Cables are the result of our decades of experience in producing high quality, long lasting, flexible cables. The innovative core design maximizes efficiency and minimizes lost motion, while the exclusive design of the conduit provides extremely high level of flexibility.



MACHZero

MACH5

MACH14

MACH36

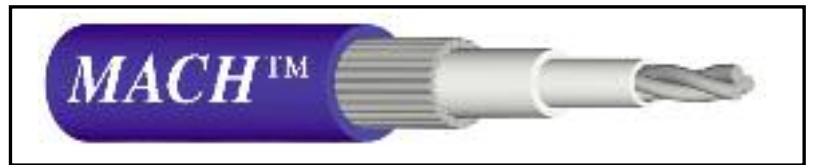

FEATURES AND PERFORMANCE

- Available in the following configurations:
 - **MACHZero** - Universal style (like C2, C8)
 - **MACH5** - Mercury® style (like C5)
 - **MACH14** - Current BRP® (OMC®) style (like C14)
 - **MACH36** - Gen II Mercury® style (like C36)
- Suitable for outboard – inboard and sterndrive engines
- High efficiency for smooth operation
- High flexibility for reduced bend radius. Ideal for long complex cable routings
- Maintenance free
- Stainless steel cables end fittings
- High resistance blue outer jacket against abrasion, UV and chemicals

CONTROL CABLES FOR WEBER® ENGINES

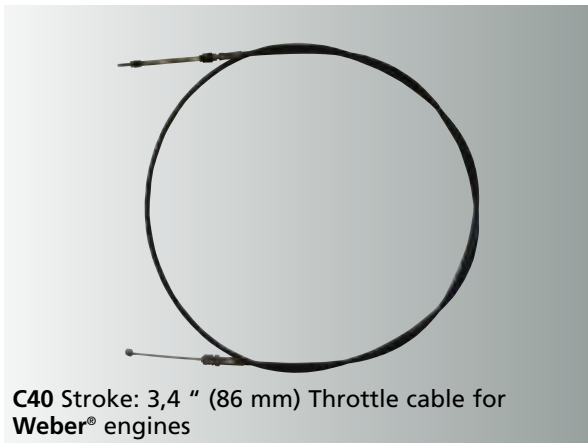

C40 Stroke: 3,4 " (86 mm) Throttle cable for Weber® engines

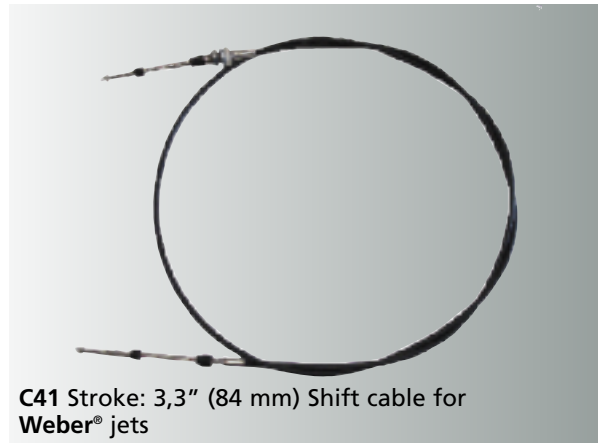

C41 Stroke: 3,3" (84 mm) Shift cable for Weber® jets

ENGINE CONTROL CABLES

- C2** Stroke: 3.4" (87 mm)
For use with inboard, sterndrive and outboard engines with appropriate accessories.
- C8** Stroke: 3.4" (87 mm)
For use with inboard, sterndrive and outboard engines, with appropriate accessories.
- MACHZero** Stroke: 3.4" (87 mm).
For use with inboard, sterndrive and outboard engines.
Ideal for high performance applications, long cable runs and complex routings. Blue color jacket.
- C4** Stroke: 3.1" (80 mm)
For BRP® - Evinrude® (OMC®) engines manufactured before 1979.
- C14** Stroke: 3" (75 mm)
For BRP® - Evinrude® (OMC®) engines manufactured from 1979 to date.
- MACH14** Stroke: 3" (75 mm).
For BRP® - Evinrude® (OMC®) engines manufactured from 1979 to date.
Blue color jacket.
High performance applications.
- C36** Stroke: 3.3" (85 mm)
For Mercury® and Mercruiser® engines and Mercury® Generation II™ series controls.
- MACH36** Stroke: 3.4" (85 mm).
For Mercury® and Mercruiser® engines and Mercury® Generation II™ series controls.
Blue color jacket.
High performance applications.
- C5** Stroke: 3.75" (95 mm)
For Mercury® and Mercruiser® engines.
- MACH5** Stroke: 3.75" (95 mm).
For Mercury® and Mercruiser® engines. Blue color jacket.
High performance applications.
- C16** Stroke: 3.1" (80 mm).
For Mariner® engines up to 40 hp.
- C25** Stroke: 3.1" (80 mm)
For Volvo® engines using BRP® (OMC®) top mount controls.
- C22** Stroke: 3.1" (80 mm)
Stainless steel clamp fittings.
Recommended for heavy duty applications.
- C23BC** Stroke: 3.1" (80 mm)
Bulkhead mount 4300 type cable
Stainless steel clamp fitting and bulkhead fitting recommended for heavy duty applications.
- B14** Stroke: 2.8" (70 mm)
Designed for throttle, fuel shut-off and other applications. Supplied with L13 and L14 clamp and shim.
- C40** Stroke: 86 mm (3.4")
Throttle cable for Weber® engines
- C41** Stroke: 84 mm (3.3")
Shift Cable for Weber® Jets

Part number for ordering:
Example: C2 XXL - LL = Length

UNIVERSAL 3300 STYLE CABLES

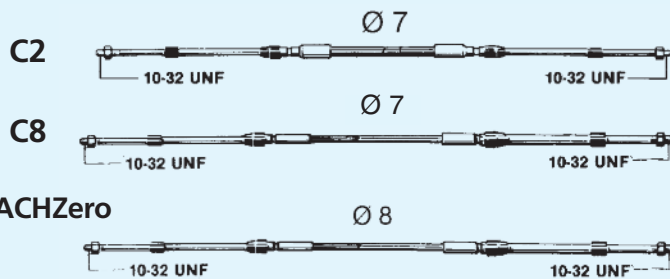

BRP® - EVINRUDE® (OMC®) CABLES

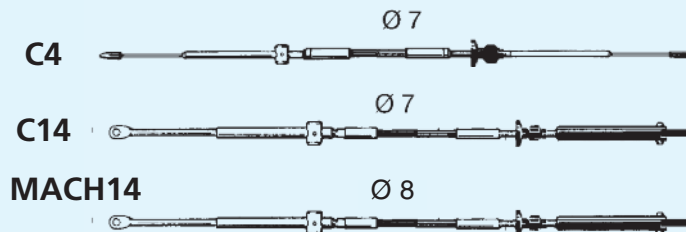

MERCURY® - MERCUISER® - MARINER® - VOLVO® CABLES

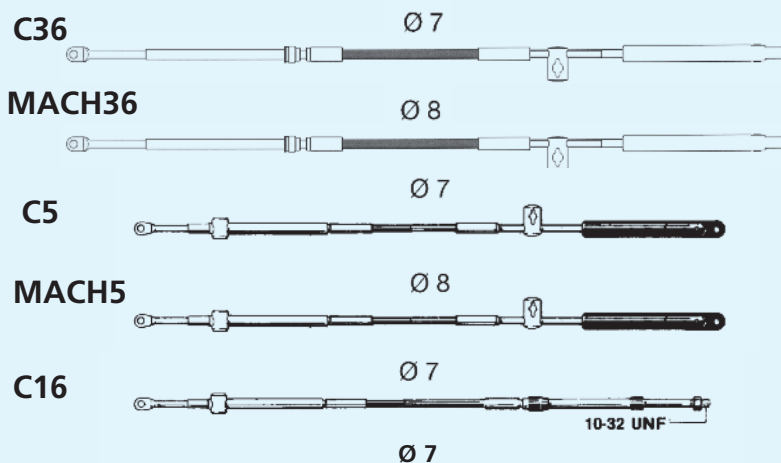

UNIVERSAL 4300 STYLE CABLES

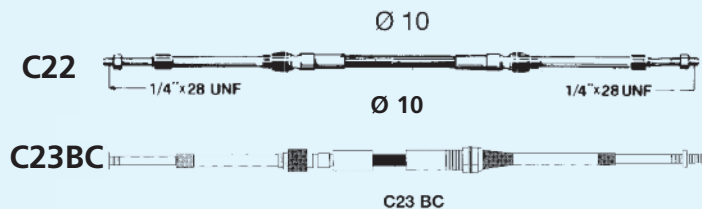

ENGINE STOP CABLE





ACCESSORIES FOR ENGINE CONTROL CABLES

L2 - 30324 D: Cable clamp block

L3 - 30325 E: Shim and clamp block.
Fits C2, C8, MACHZero and all 33C style cables.

L7 - 38078 U: Ball joint 10-32 UNF.
Stainless steel, fits C2, C8, MACHZero and all 33C style cables.

L12 - 30334 F: Cable end fitting.
Fits C2, C8, MACHZero and all 33C style cables.

L13 - 30335 G: Stop collar. Fits C4 and B14 cables.

L14 - 30336 H: Cable clamp block.
Fits C2, C8, MACHZero and all 33C style cables.

L25 - 31906 D: Clevis 10-32 UNF.
Fits C2, C8, MACHZero and all 33C style cables.

L26 - 33517 N: Clevis 1/4" x 28 threaded. Fits C22 and 4300 series cables.

K56 - 39237 C
Adapts C2, C8, MACHZero and all 33C style cables for use with Mercury® engines.

K57 - 39238 E
Adapts C2, C8, MACHZero and all 33C style cables for use with BRP® - Evinrude® engines.



L2



L3

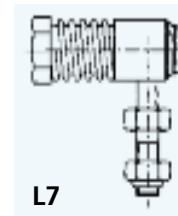

L7



L12



L13



L14



L25



L26

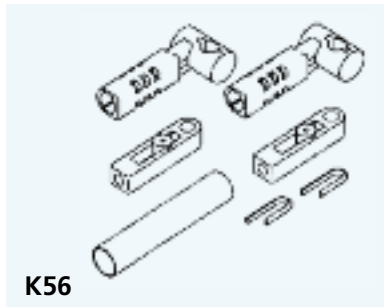

K56

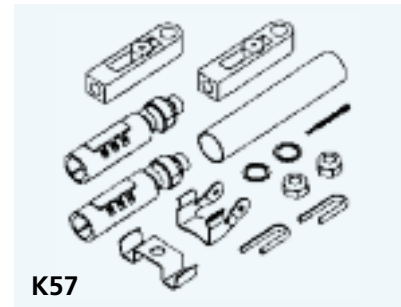

K57

CONTROL CABLE APPLICATION MATRIX

SINGLE LEVER CONTROLS

MODEL	B400 B401	B183 - B184 B85 B310CH - B310BR - B310B	B301 B302	B103	B104	B65 - B66 - B73 B74 - B76 - B77 B78 - B79	B89 B90
C2	X	X	K59*	X	X	X	X
C8	X	X	K59*	X	X	X	X
C4	-	-	-	-	-	-	-
C14	K71	X	X	-	-	X	X
C5	K72	K35	K60	-	-	K35	K35
C36	K73	-	K62	-	-	-	-
C16	K72	K35	K60	-	-	K35	K35
C22	-	-	K61	K33	-	-	-
MACHZero	X	X	K59*	X	X	X	X
MACH5	K72	K35	K60	-	-	K35	K35
MACH36	K73	-	K62	-	-	-	-
MACH14	K71	X	X	-	-	X	X

*: Supplied with the control

X: No kit required

- : No connection

TWO LEVER CONTROLS

MODEL	B322 B324	B46 - B50 - B58 B59 - B203 - B204 B207 - B208	B101 - B102	B47 - B49	B35
C2	K67*	X	X	K25	X
C8	K67*	X	X	K25	X
C4	-	-	-	K24	-
C14	X	-	-	K23	-
C5	K63	-	-	X	-
C36	K65	-	-	-	-
C16	K63	-	-	X	-
C22	K64	K22	K32	-	-
MACHZero	K67*	X	X	K25	X
MACH5	K63	-	-	X	-
MACH36	K65	-	-	-	-
MACH14	X	-	-	K23	-

*: Supplied with the control

X: No kit required

- : No connection



115



UFLEX®
Manufactured By MARESI LTD
an ULTRAFLEX GROUP Company



ELECTROMECHANICAL TRIM TABS

UFLEX MT ELECTROMECHANICAL TRIM TAB SYSTEMS

Improve fuel economy and passenger comfort with Uflex electromechanical trim tabs. Featuring electropolished stainless steel planes and low consumption, high speed, composite actuators, these tabs are built to last in the most demanding sea conditions.

These tabs have been specifically designed for easy installation using a quick connect bracket-actuator, requiring only one small hole per tab through the transom. The patented transom mounting bracket encapsulates the wiring to ensure protection against any wiring damage.

Uflex MT Trim tabs are available in 2 versions:

MTW systems with white actuators and brackets

MTB systems with black actuators and brackets

FEATURES

- Hardened steel free wheeling ballscrew
- **EASYJOY**: prompt and easy control with the innovative use of a Joystick
- **AUTO LINE-UP**: automatic flap re-alignment function
- Completely sealed and fully submersible tab actuators: maximum protection guaranteed by dual seals and a rubber bellow
- Snap-in system (PATENTED) with protected harness for an easy installation
- Stainless steel rod and tabs
- System requires no maintenance
- Voltage: 12V DC or 24V DC
- Waterproof: IP68 protection
- Actuator total length (full closed): 11.8" (301 mm)
- Stroke: 2.25" (57 mm)

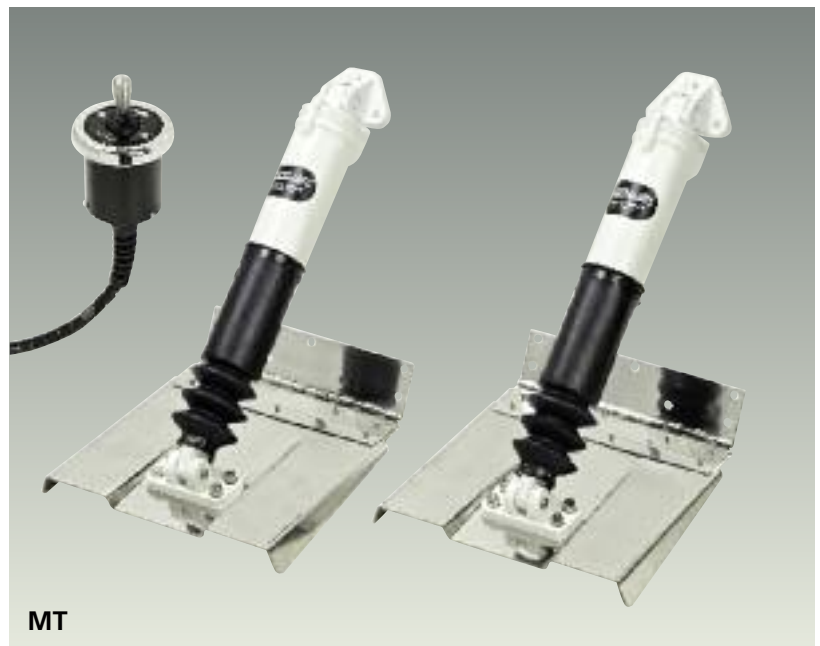

MT

ONE ACTUATOR PER TAB COMPLETE SET:

- 1 pair of stainless steel tabs. Tabs are sold separately: selected model to be specified when ordering
- 1 pair of electromechanical actuators complete with connection brackets (white or black version)
- 1 control unit Easyjoy (joystick) with wiring harness included

TWIN ACTUATOR PER TAB COMPLETE SET:

- 1 pair of stainless steel tabs. Tabs are sold separately: selected model to be specified when ordering
- 2 pair of electromechanical actuators complete with connection brackets (white or black version)
- 1 control unit Easyjoy (joystick) with wiring harness included

BOAT LENGTH	BOAT LENGTH (m)	TAB SIZE (length x width)	TAB SIZE (cm)
14' - 18'	4,5 - 5,5	9" x 9"	22,8 x 22,8
16' - 25'	5,0 - 8,0	12" x 9"	30,5 x 22,8
18' - 30'	5,5 - 9,0	12" x 12"	30,5 x 30,5
26' - 36'	8,0 - 11,0	18" x 12"	45,7 x 30,5

These recommendations should be used as a general reference only. Final selection should be made with the assistance of a qualified installation technician. For any further information please contact our Technical Service

CONTROL UNIT

EASYJOY 41849 Z

Compact control unit with Joystick.

Auto line-up function included (automatic flap re-alignment).

Wiring harness included.



EASYJOY

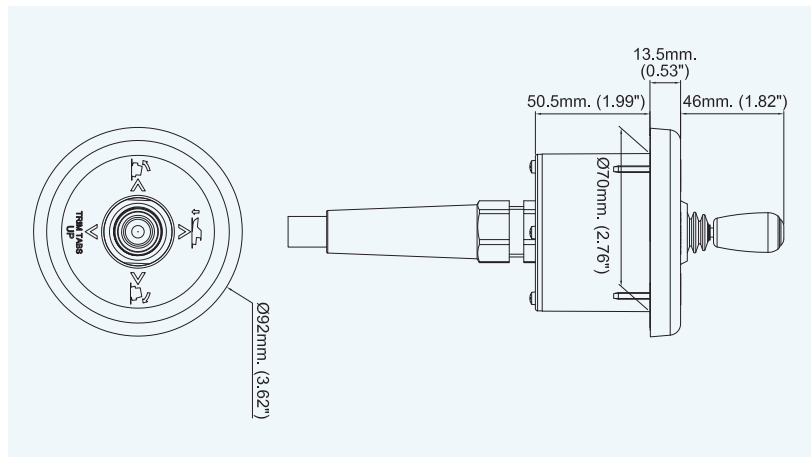

EASYJOY DIMENSIONS

COMPONENTS AND SPARE PARTS

MODEL	PART No.	DESCRIPTION
AW12	41838 U	White Actuator 12 VDC
AW24	41839 W	White Actuator 24 VDC
AB12	41842 J	Black Actuator 12 VDC
AB24	41843 L	Black Actuator 24 VDC
P99	41844 N	Stainless steel tab pair 9" x 9"
P912	41845 R	Stainless steel tab pair 9" x 12"
P1212	41846 T	Stainless steel tab pair 12" x 12"
P1218	41847V	Stainless steel tab pair 12" x 18"
EASYJOY	41849 Z	Jostick

TAB WEIGHT

MODEL	WEIGHT PER PAIR KG (LBS)
P99	2.8 kg (6.2 lbs)
P912	3.6 kg. (7.9 lbs)
P1212	4.6 kg. (10.1 lbs)
P1218	6.7 kg. (14.8 lbs)



AW12 - AW24



AB12 - AB24

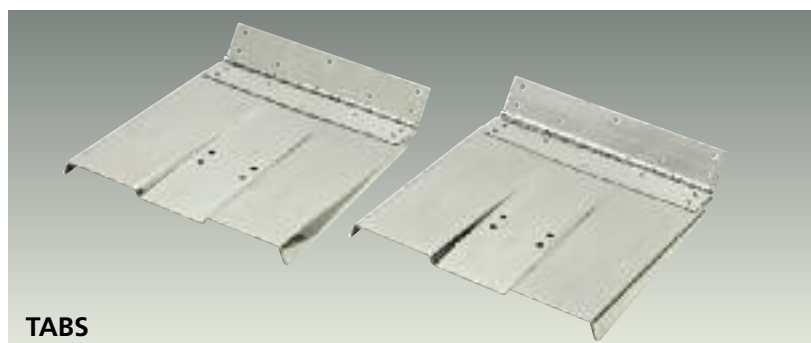

TABS





BENNET® REPLACEMENT ADAPTING BRACKET

BRK Bennet® - 41855U

Bracket to adapt Uflex MT trim tabs to pre-existing mounting holes, in case of Bennet® replacement.
Screws included.



118

PACKAGED MT TRIM TAB SYSTEM SET

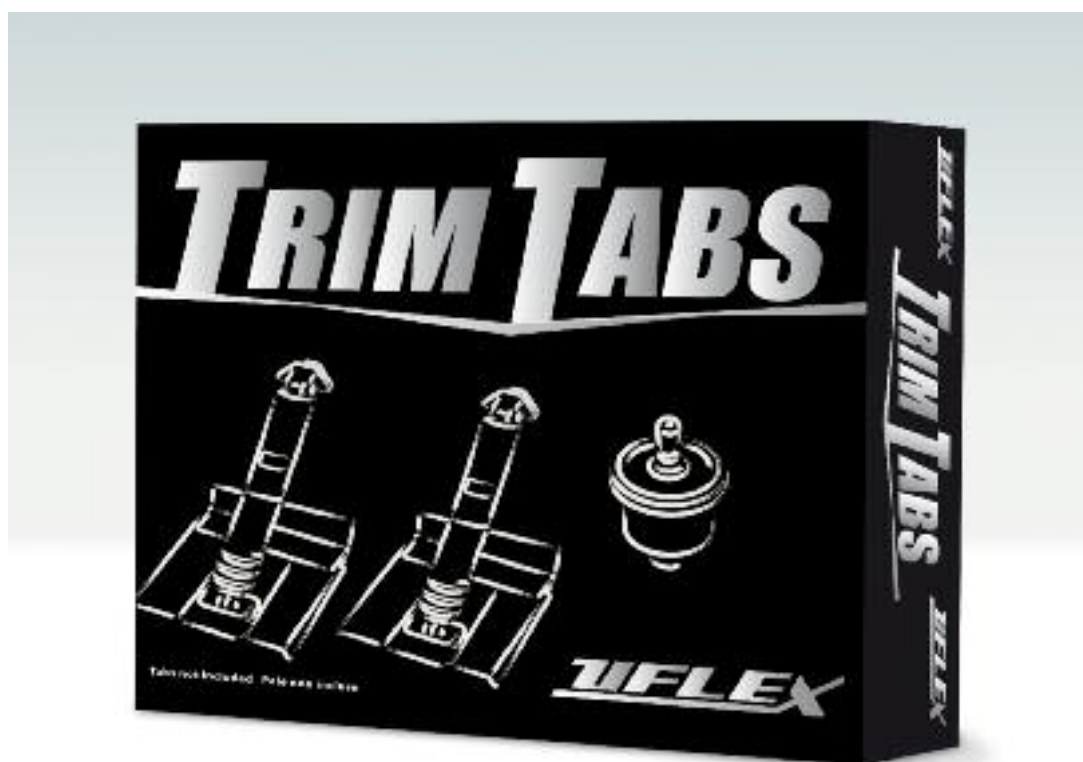

The prepackaged MT set includes 1 pair of actuators complete with brackets and 1 EASYJOY Joystick. The tabs are not included and sold separately: selected model has to be specified when ordering.

WHITE ACTUATOR SET - 12VDC

MODEL	PART No.	DESCRIPTION
MTW12	41854S	2 white actuators 12VDC + 1 Easyjoy Joystick

WHITE ACTUATOR SET - 24VDC

MODEL	PART No.	DESCRIPTION
MTW24	41858A	2 white actuators 24VDC + 1 Easyjoy Joystick

BLACK ACTUATOR SET - 12VDC

MODEL	PART No.	DESCRIPTION
MTB12	41864V	2 black actuators 12VDC + 1 Easyjoy Joystick

BLACK ACTUATOR SET - 24VDC

MODEL	PART No.	DESCRIPTION
MTB24	41868B	2 black actuators 24VDC + 1 Easyjoy Joystick



119



WES[®]
ULTRAFLEX CONTROL SYSTEMS s.r.l.



HATCH LIFTERS

AV SERIES ELECTRICAL HATCH LIFTERS

Constructed of anodized aluminum and stainless steel, the Uflex hatch lifters are built to last. Lifting with up to 265 Lbs of force, these actuators are an ideal solution for controlling engine hatches, lazarets, doors and other on board fixtures.

A unique sleeve on the AV "Non Locking" version of these actuators allows you to manually open the hatch in the event of power loss i.e. weak batteries. For high performance applications where the hatch could blow open, we recommend the AVL series which pushes as well as pulls with 265 Lbs.

All mounting hardware is included.

TECHNICAL FEATURES

- According to the load required, the AV hatch lifter can be mounted individually, or in twin cylinder installation for heavier loads. It is also possible to install more than two AV actuators in multiple applications.
- **Maximum load for single installations: 1200N (120 kg - 265 lbs)**
- **Maximum load for dual installations: 2400N (240 kg - 529 lbs)**
- Maximum load is recommended not to be exceeded.
- Supplied with all mounting hardware.
- Stainless steel telescopic ram for manual operation in case of emergency.
- Locking version (AV-L) recommended for high performance applications.
- Circuit breaker to stop accidental overloading of the system and electronic stop at closed or full open position.
- IP 65 protection rated
- Speed: 25mm/sec no load applied, 17 mm/sec maximum load
- Current absorption in single installations: 10A at 12V, 5A at 24V
- Current absorption in dual installations: 20A at 12V, 10A at 24V
- AV 12VDC models are Ignition Protected. UL1500 - ISO8846 approved.

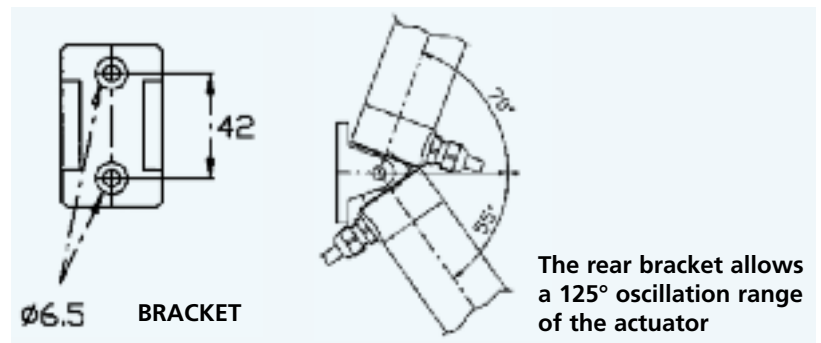
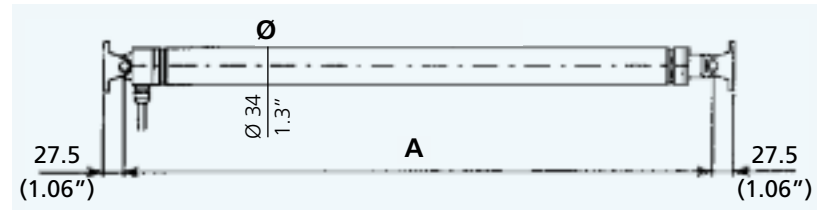

The rear bracket allows a 125° oscillation range of the actuator

SPARE FIXING BRACKET:
BR/AV - 80382 I

AV SERIES - SINGLE ACTION

MODEL	PART No.	VOLTS	STROKE	LENGTH A (FULL CLOSED ACTUATOR)	EXTERNAL DIA.
AV 3012	40671 C	12 V DC	12" - 300 mm	27" - 677 mm	1,9" - 48 mm
AV 4512	40582 D	12 V DC	18" - 450 mm	33" - 827 mm	1,9" - 48 mm
AV 6012	40584 H	12 V DC	24" - 600 mm	39" - 977 mm	1,9" - 48 mm

AV-L SERIES - LOCKING - DUAL ACTION

MODEL	PART No.	VOLTS	STROKE	LENGTH A (FULL CLOSED ACTUATOR)	EXTERNAL DIA.
AV-L 3012	40703 P	12 V DC	12" - 300 mm	27" - 677 mm	1,9" - 48 mm
AV-L 4512	40590 D	12 V DC	18" - 450 mm	33" - 827 mm	1,9" - 48 mm
AV-L 6012	40592 G	12 V DC	24" - 600 mm	39" - 977 mm	1,9" - 48 mm

WARNING: The AV Series hatch lifters can be opened freely in the event of a power failure, and can therefore open while underway. The AV Series hatch lifters are not intended for use on high performance boats or in applications where the hatch may open unintentionally. For these applications we recommend the AV-L series hatch lifters, which stay locked when the actuator is in the closed position.

ULYSSES SERIES ELECTRICAL LINEAR ACTUATORS

TECHNICAL FEATURES

- **Single installation only**
- **Pull and push maximum load: 650N (65 kg - 144 lbs)**
- Pull and push maximum load is recommended not to be exceeded.
- Supplied with all mounting hardware.
- Aluminium ram.
- Circuit breaker to stop accidental overloading of the system and electronic stop at closed or full open position.
- IP 65 protection rated
- Speed: 5 mm/sec no load applied, 4 mm/sec maximum load
- Current absorption: 2A

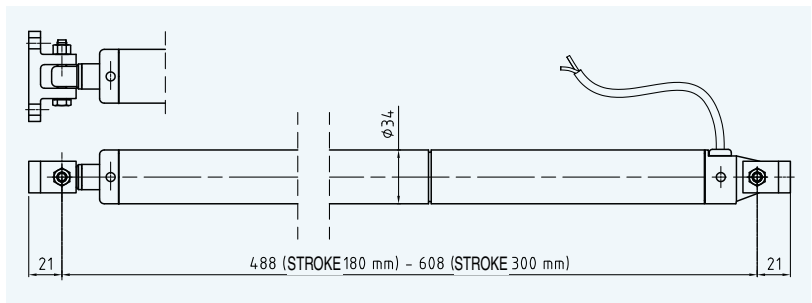

Highest installation flexibility: 180° oscillation range

MODEL	PART No.	VOLTS	STROKE	LENGTH A (FULL CLOSED ACTUATOR)	EXTERNAL DIA.
ULYSSES 1812	40924 Q	12V DC	7" - 180 mm	19.2" - 488 mm	1.3" - 34 mm
ULYSSES 3012	40925 R	12V DC	12" - 300 mm	23.9" - 608 mm	1.3" - 34 mm

SPARE FIXING BRACKET: BR/UL - 35697 P

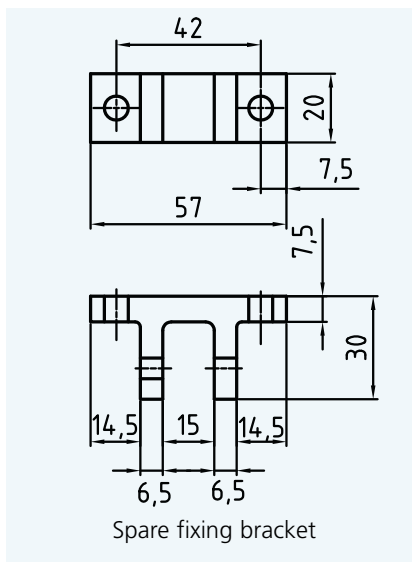

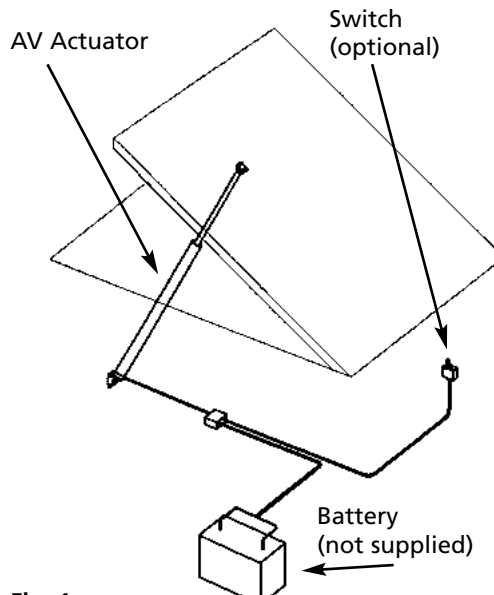

Fig. 1

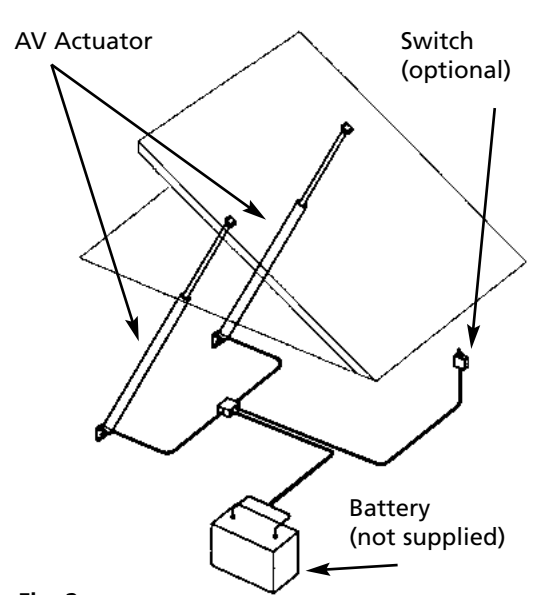

Fig. 2

COMPONENTS DESCRIPTION

AV Series Hatch Lifters

- n° 1 AV actuator for single installation (Fig.1)
- n° 2 AV actuators for dual installation (Fig.2)
- External diameter: 1.9" (48 mm)
- Length at closed position: 14.8" (377 mm)+ stroke
- Maximum oscillation range: 125°

ULYSSES Series actuators

- n° 1 Ulysses actuator (Fig.1) **no dual installation**
- External diameter: 1.3" (34 mm)
- Length at closed position: 12.1" (308 mm)+ stroke
- Maximum oscillation range: 180°

Power supply cable:

- **AV** and **ULYSSES** actuators are supplied with 5 ft (1,5 m) of electrical cable
- Warning: in case of longer cable length required, do not substitute the existing harness, but make a junction following the instructions supplied with the product.

Two way push-button with central off position not supplied

Fuse (not supplied)

Battery (not supplied)

INSTALLATION

- The following equation will help you to calculate the maximum strength (Fmax) required from the hatch lifter to open your hatch, knowing the dimensions and weight of the hatch and the position of the mounting brackets.

$$F_{max} = \frac{P}{2} \times \frac{d}{b} \times \frac{L}{a}$$

P = weight of the hatch in Newton
 c, a, b = dimensions in metres indicated in Fig. 3 and Fig. 4
 L = hatch lifter length when in closed position

Maximum load (Fmax):

- **AV Series actuators:**
 1200 N (120 kg - 265 lbs) single installation, pushing only
 2400 N (240 kg - 530 lbs) dual installation pushing only
Note: when the load exceeds 2400 N (240 kg - 530 lbs), it is possible to install more than two AV actuators

- **ULYSSES actuators:**
 650 N (65 kg - 144 lbs) single installation only, both pull and push

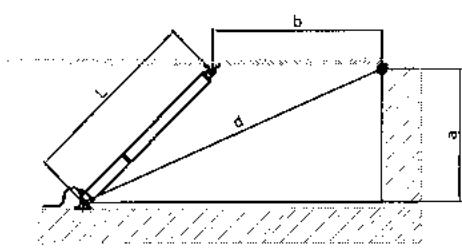

Fig. 3

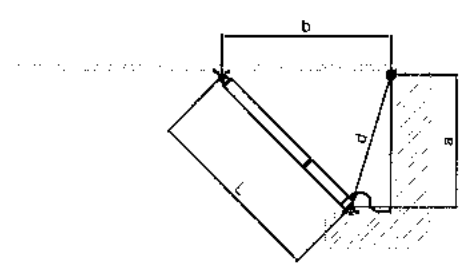

Fig. 4



WIFLEX

MAGNETIC
COMPASSES

UFLEX COMPASSES

Uflex offers a wide choice of models and styles of compasses both for power and sail boats. Mounting options vary from bulkhead, flush or bracket mounting to deck or pedestal assembly. Every Uflex compass is individually calibrated to ensure precision in highly variable temperatures.

POWERBOAT COMPASSES

Easy to read, stylish compasses, they are extremely reliable and highly stable thanks to the unique shock absorber system.



SAILBOAT COMPASSES

With their low inertia card design that provides high stability and readability in all conditions, these compasses represent the best value in sailing. The 45° lubber lines and the 45° built-in clinometer give the helmsman instant reference points for tacking and heel angle.

CARD BALANCING

The cards in magnetic compasses are balanced to compensate for the dip caused by the earth's magnetic field. All Uflex compasses are standard balanced for use in the Northern Hemisphere (Zone A). When ordering compasses to be used in the Southern Hemisphere (Zone B-C), please specify the zone number of your boating area.

SERIES	MODEL	APP. DIAL Ø	DUAL COLOR	MOUNTING FL: flush mount BR: bracket BI: binnacle BU: bulkhead	COLOUR OF HOUSING B: black W: white G: gray CR: chrome	TILTING ANGLE fore and aft Roll	CLINOMETER	COMPENSATORS	ILLUMINATION
A M A L F I	A-65 L BI/B	2½"	BLACK	BINNACLE	BLACK	± 30°			●
	A-65 L BI/W	2½"	WHITE	BINNACLE	WHITE	± 30°			●
	A-65 L BI/G	2½"	BLACK	BINNACLE	GRAY	± 30°			●
	A-65 L BI/CH	2½"	BLACK	BINNACLE	CHROME	± 30°			●
	A-65 L BR/B	2½"	BLACK	BRACKET	BLACK	± 30°			●
	A-65 L BR/W	2½"	WHITE	BRACKET	WHITE	± 30°			●
	A-65 L BR/G	2½"	BLACK	BRACKET	GRAY	± 30°			●

P I S A	P-80 BR/B	3"	BLACK	BRACKET	BLACK	± 30°		●	●
	P-80 BR/W	3"	WHITE	BRACKET	WHITE	± 30°		●	●
	P-80 BR/G	3"	BLACK	BRACKET	GRAY	± 30°		●	●
	P-80 FL/B	3"	BLACK	FLUSH MOUNT	BLACK	± 30°		●	●
	P-80 FL/W	3"	WHITE	FLUSH MOUNT	WHITE	± 30°		●	●
	P-80 FL/G	3"	BLACK	FLUSH MOUNT	GRAY	± 30°		●	●
	P-80 BI/B	3"	BLACK	BINNACLE	BLACK	± 30°		●	●
	P-80 BI/W	3"	WHITE	BINNACLE	WHITE	± 30°		●	●
	P-80 BI/G	3"	BLACK	BINNACLE	GRAY	± 30°		●	●
	P-80 LP/B	3"	BLACK	LOW PROFILE	BLACK	± 30°			●
	P-80 LP/W	3"	WHITE	LOW PROFILE	WHITE	± 30°			●
	P-80 LP/G	3"	BLACK	LOW PROFILE	GRAY	± 30°			●
	P-90 BU/B	3½"	BLACK	BULKHEAD	BLACK	± 30°	●	●	●
	P-90 BU/W	3½"	WHITE	BULKHEAD	WHITE	± 30°	●	●	●
	P-80 BU/CH	3½"	BLACK	BULKHEAD	CHROME	± 30°	●	●	●
	P-80 BU/S	3½"	SECTOR	BULKHEAD	BLACK	± 30°	●	●	●

series
P-80 BR/B
color of housing

apparent diameter dial (mm)
mounting

3 YEARS GUARANTEE

Our magnetic compasses are guaranteed, for a period of three years from the manufacture date, against defects in material and workmanship. Alleged defective products returned, freight prepaid, within the above said term, will be repaired or replaced at our option, free of charge, if found effectively below our quality standards.

This guarantee does not cover other claims for direct or indirect damage. In particular, we decline liability and exclude guarantee (except for what stated above) if improper installation or misuse should result in the failure of our products.



A-65 AMALFI SERIES

- 2 1/2" (65 mm) apparent diameter dial
- front reading dial
- 5° dial graduation
- compact low profile
- snap-in mounting feature for easy removal
- binnacle or bracket installation
- shock resistant and antiscratching polycarbonate dome
- standard models with internal LED illumination
- black, grey, white and chrome (binnacle only) housing
- clamshell or box standard packaging

A-65 BINNACLE INSTALLATION (BI)

Low profile binnacle mounting compass that can be easily removed from its base acting on the snap-in mounting bracket.

Clamshell packaging

Without Illumination

- A-65 BI/B - 39320 N Black
- A-65 BI/W - 39377 V White
- A-65 BI/G - 39375 R Grey
- A-65 BI/CH - 40901 T Chrome plated

With Illumination

- A-65 L BI/B - 39350 Y Black
- A-65 L BI/W - 39351 A White
- A-65 L BI/G - 39379 Z Grey
- A-65 L BI/CH - 40903 X Chrome plated

Box packaging

Without Illumination

- A-65 BI/B box - 39382 M Black
- A-65 BI/W box - 39383 P White
- A-65 BI/G box - 39384 S Grey
- A-65 BI/CH box - 40905 B Chrome plated

With Illumination

- A-65 L BI/B box - 39385 U Black
- A-65 L BI/W box - 39386 W White
- A-65 L BI/G box - 39387 Y Grey
- A-65 L BI/CH box - 40907 F Chrome plated

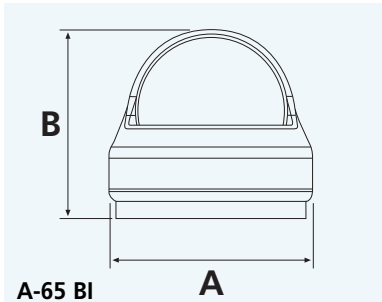

A	86 mm - 3.39"
B	78 mm - 3.1"

MOUNTING VERSATILITY

Order BRACKET 65 if you wish to transform your A-65 BI binnacle compass in a A-65 BR bracket compass.

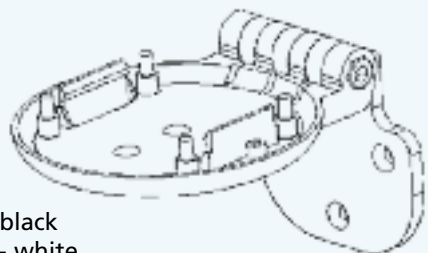

- BRACKET 65/B - 39356 L - black
- BRACKET 65/W - 40109 A - white
- BRACKET 65/G - 40110 J - grey



A-65 BR/G



A-65 BR/W



A-65 BR/B



A-65 AMALFI SERIES

- 2 1/2" (65 mm) apparent diameter dial
- front reading dial
- 5° dial graduation
- compact low profile
- snap-in mounting feature for easy removal
- binnacle or bracket installation
- shock resistant and antiscratching polycarbonate dome
- standard models with internal LED illumination
- black, grey, white and chrome (binnacle only) housing
- clamshell or box standard packaging

A-65 BRACKET INSTALLATION (BR)

The bracket version of the A-65 Amalfi series compass is designed for multiple mounting capabilities both in a horizontal or inclined dashboard or a bulkhead. It can be easily removed from its bracket acting on the snap-in mounting system

Clamshell packaging

Without Illumination

- A-65 BR/B - 39321 R Black
- A-65 BR/W - 39378 X White
- A-65 BR/G - 39376 T Grey

With Illumination

- A-65 L BR/B - 39352 C Black
- A-65 L BR/W - 39353 E White
- A-65 L BR/G - 39380 H Grey

Box packaging

Without Illumination

- A-65 BR/B box - 39388 A Black
- A-65 BR/W box - 39389 C White
- A-65 BR/G box - 39390 L Grey

With Illumination

- A-65 L BR/B box - 39391 N Black
- A-65 L BR/W box - 39392 R White
- A-65 L BR/G box - 39393 T Grey

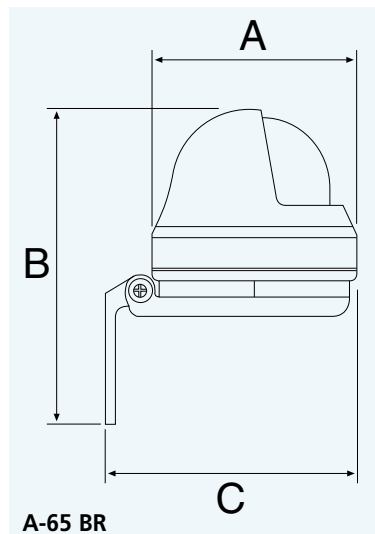

A	86 mm - 3.39"
B	132 mm - 5.2"
C	106 mm - 4.17"



P-80 PISA SERIES

- 3" (80 mm) apparent diameter dial
- front reading dial
- low and compact profile
- bracket, flush, binnacle and bulkhead mount choice
- semi-gimbal system
- internal LED illumination
- built-in compensators (P-80 LP models excepted)
- available in black, white and gray housing
- 5° dial graduation
- single box packaging
- All Pisa series compasses meet the D.M. 388 29/09/1999 art. 3, paragraph 2.

P-80 BRACKET MOUNT (BR)

Bracket mount compasses easy to install in multiple ways both on a dashboard or a cabin overhead. The compass can be easily removed from its brackets by loosening the two sidemounted amagnetic screws.

- P-80 BR/B 39591 X – front reading, black housing and card
- P-80 BR/W 39597 K – front reading, white housing and card
- P-80 BR/G 39593 B – front reading, gray housing, black card

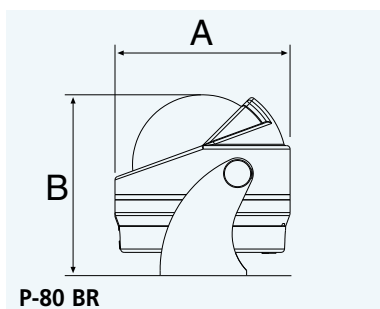

A	100 mm - 3.9"
B	103.5 mm - 4.1"



P-80 FL/G

P-80 FL/W

P-80 FL/B



P-80 PISA SERIES

- 3" (80 mm) apparent diameter dial
- front reading dial
- low and compact profile
- bracket, flush, binnacle and bulkhead mount choice
- semi-gimbal system
- internal LED illumination
- built-in compensators (P-80 LP models excepted)
- available in black, white and gray housing
- 5° dial graduation
- single box packaging
- All Pisa series compasses meet the D.M. 388 29/09/1999 art. 3, paragraph 2.

P-80 FLUSH MOUNT (FL)

Flush mount compasses designed for mounting on top of an instrument panel or any flat surface from horizontal plane to 45° fore and aft tilt.

- P-80 FL/B 40162 E – front reading, black housing and card
 P-80 FL/W 40163 G – front reading, white housing and card
 P-80 FL/G 41203 X – front reading, gray housing, black card

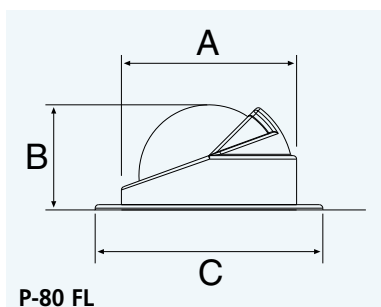

P-80 FL

A	100 mm - 3.9"
B	60 mm - 2.36"
C	130 mm - 5.1"

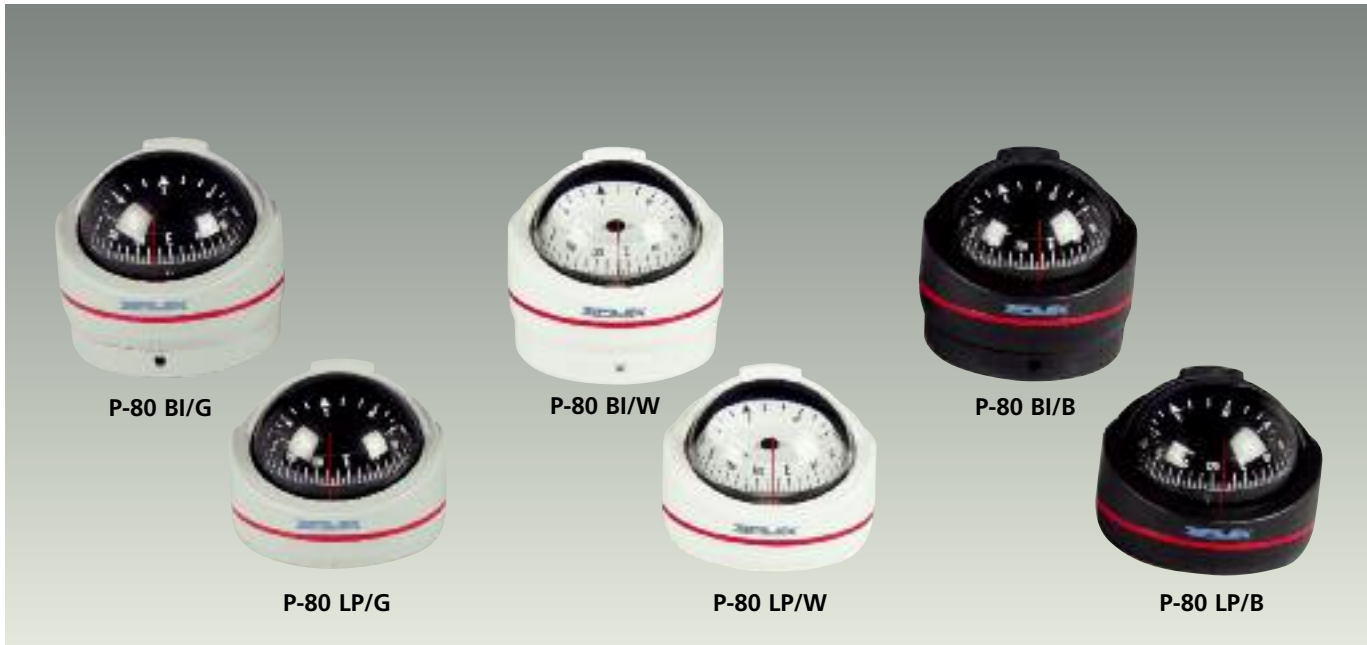

P-80 PISA SERIES

- 3" (80 mm) apparent diameter dial
- front reading dial
- low and compact profile
- bracket, flush, binnacle and bulkhead mount choice
- semi-gimbal system
- internal LED illumination
- built-in compensators (P-80 LP models excepted)
- available in black, white and gray housing
- 5° dial graduation
- single box packaging
- All Pisa series compasses meet the D.M. 388 29/09/1999 art. 3, paragraph 2.

P-80 BINNACLE MOUNT (BI)

- P-80 BI/B 40164 J – front reading, black housing and card
- P-80 BI/W 40165 L – front reading, white housing and card
- P-80 BI/G 41244 M – front reading, gray housing, black card

P-80 BINNACLE MOUNT "LOW PROFILE" (LP)

- P-80 LP/B 41245 P – front reading, black housing and card
- P-80 LP/W 41246 S – front reading, white housing and card
- P-80 LP/G 41247 U – front reading, gray housing, black card

NOTE: Compensation is not included in P-80 LP models.

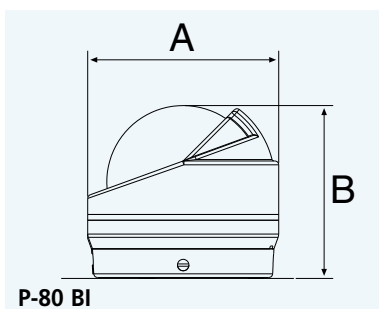

A	100 mm - 3.9"
B	75,5 mm - 3"

A	100 mm - 3.9"
B	90,5 mm - 3.6"

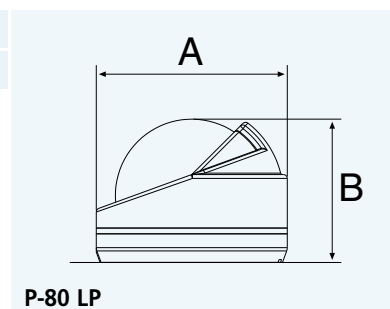



P-90 PISA SERIES

- 3.5" (90 mm) apparent diameter dial
- front reading dial
- low and compact profile
- bracket, flush, binnacle and bulkhead mount choice
- semi-gimbal system
- internal LED illumination
- built-in compensators (P-80 LP models excepted)
- available in black, white, chrome and titanium (bulkhead only) housing
- 5° dial graduation
- single box packaging
- All Pisa series compasses meet the D.M. 388 29/09/1999 art. 3, paragraph 2.

P-90 BULKHEAD MOUNT (BU)

Bulkhead or panel mount compasses ideal for both sailing and motor boats. The gimbaling system allows them to be mounted on a vertical or up to 45° front sloping console.

- P-90 BU/B** 41248 W – front reading, black housing and card
- P-90 BU/W** 41249 Y – front reading, white housing and card
- P-90 BU/CH** 41250 G – front reading, chrome plated housing, black card
- P-90 BU/T** 41251 J – front reading, titanium housing, black card
- P-90 BU/S** 41252 L – front reading, black housing, sector card

- SCB-90** 41253 N – optional black cover
- SCW-90** 41254 R – optional white cover

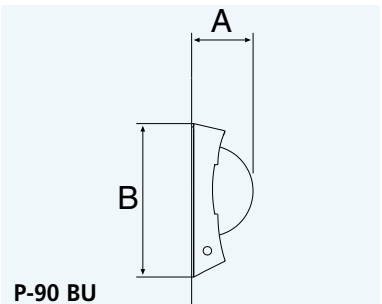

A	58.5 mm - 2.3"
B	146 mm - 5.75"



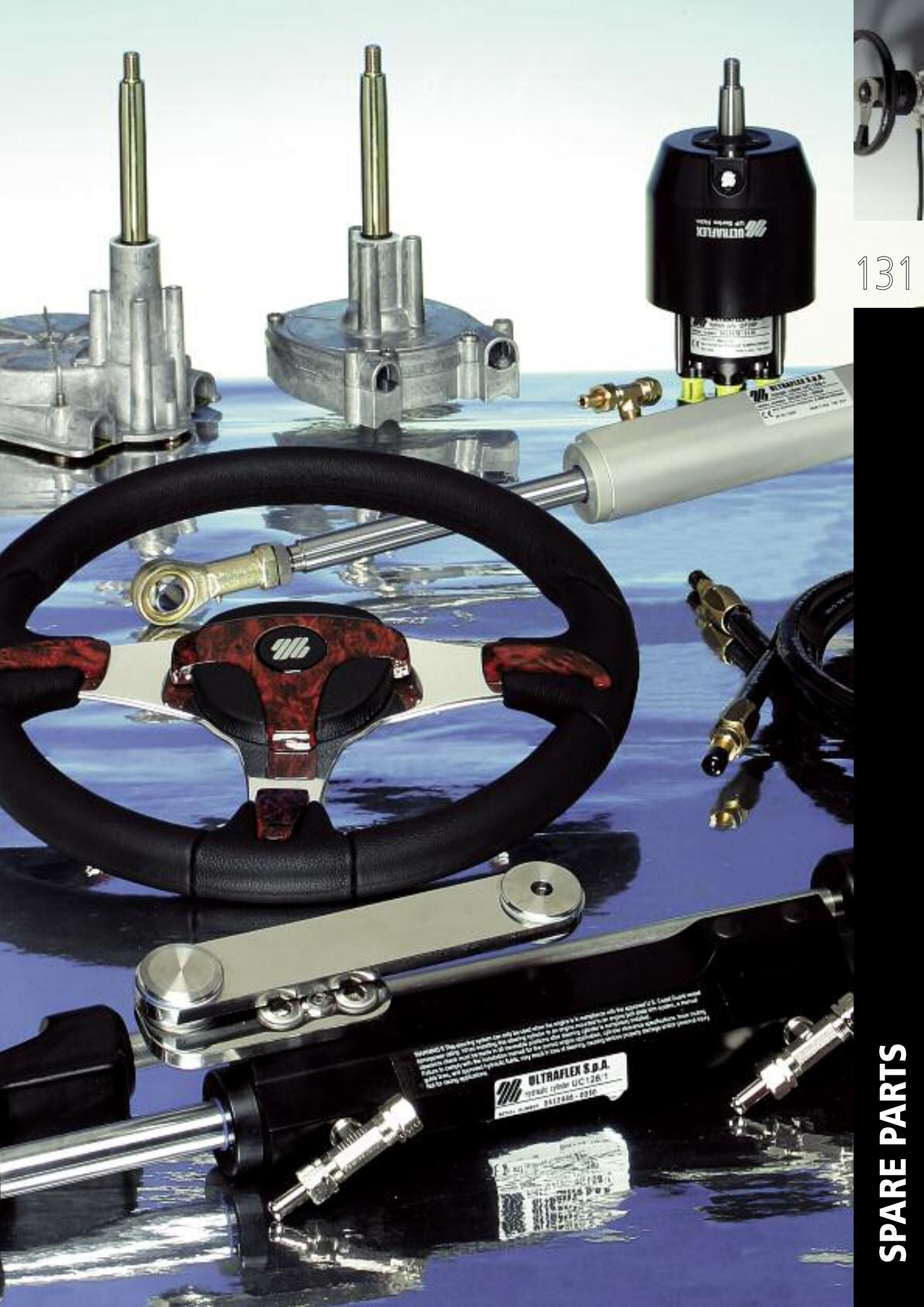

MECHANICAL PRODUCTS

T71FC - T72FC - T73NRFC

90° Black bezel	58051 L
90° W White bezel	71942 H
Shaft kit	70549 A
Cable lock-in screw	70022 G
Spent travel nylon tube	59869 F
Plastic ferrule for nylon tube	59857 Z

X52 Tilt Mechanism

Upper cover	70123 N
Lower cover	70140 N
Gasket	70138 C

G86 - G88

2 Shaft kits	71109 A
--------------	---------

Steering Wheels

Stainless steel silver screws	60697 Q
Stainless steel black screws	60698 T
Black cap for V32	58078 Y
Black cap for V33	59763 O
Grey cap for V33	59765 Q
Black cap for V45	59061 O
White cap for V45	59002 D
Grey cap for V45	71108 Y
Black cap for Antigua	70161 X
White cap for Antigua	70162 Z
Grey cap for Antigua	70163 V
Burl wood cap for Antigua	70164 D

B301CR - B302CR - B301B - B302B - B322 - B324

Lever assembly with black knob	40897 F
Lever assembly with red knob B322 - B324	40898 H
Black knob	72054 G
Red knob	72020 N
Chrome rear cover B301CR	71461 R
Black painted rear cover B301B	71501 A
Gasket for B301CR - B301B	71366 X
Gasket for B302CR - B302B - B322 - B324	71516 P
Installation kit B301CR	40170 D
Installation kit B301B	40744 D
Installation kit B302CR	40743 B
Installation kit B302B	40192 P
Installation kit B322 - B324	40703 N

B103 - B104

Lever with handle	60909 N
Black knob	34830001
X55 Silver knob B103/B104	39421 V
Gasket for B103	61425 E
Gasket for B104	61426 G
External casing for B103	61738 C
Installation kit B103	60979 B
Installation kit B104	60804 D

B65 - B66 - B73 - B74 - B76 - B77 - B78 - B79

Lever assembly	
B66 - B65 - B73 - B74	57076 R
Lever assembly with trim	
B76 - B77 - B78 - B79	57459 E
Chrome rear cover	55529 Z
Black rear cover	55608 X
Installation kit B65	35147 J
Installation kit B66	30078 K
Installation kit B73	30049 F
Installation kit B74	35366 S
Installation kit B76	36134 F
Installation kit B77	30016 Q
Installation kit B78	36135 G
Installation kit B79	30017 R

B310CH - B310BR - B310B

Lever assembly B310CH	73158 A
Lever assembly B310BR	72119 J
Lever assembly B310B	73177 E
Screw cover flange B310CH-B310BR-B310B	72110 P
Chrome plated external flange	72108 D
B310CH - B310BR - B310B	
Black internal flange	72109 F
B310CH - B310BR - B310B Installation kit	72222 B

B183 - B184 - B85

Lever assembly B183	70013 F
Lever assembly B184	70020 C
Cover B183 - B184 - B85	56012 A
Flange B183 - B184 - B85	56011 V
Installation kit B103	38947 F
Installation kit B184	38979 V
Installation kit B85	36008 C

B89 - B90

Black lever with lock	58245 T
White lever with lock	57899 L
Installation kit B89-B90	36168 R

B46 - B50 - B58 - B59

Cover	57960 T
Black knob	32394 A
Red knob	32472 Q
Installation kit	35365 R

B203 - B204 - B207 - B208

Black cover	57960 T
White cover	59446 B
Burl wood cover	38985 P
Installation kit	35365 R

B101 - B102

Red knob B101 - B102	58266 Y
Black knob B101 - B102	53185 V
Installation kit B101 - B102	35391 A

B14 Engine Stop Cable

B14 Kit	59976 G
---------	---------

AVAILABLE SPARE PARTS

WARNING

In order to maintain the correct functionality of the product, the replacement with spare parts has to be made by qualified technicians **only**.

HYDRAULIC PRODUCTS

AVAILABLE SPARE PARTS

WARNING

In order to maintain the correct functionality of the product, the replacement with spare parts has to be made by qualified technicians **only**.

HELM PUMPS

Vented filler plug kit with valve	40801 N
Non vented filler plug kit	40800 L
Shaft seal kit	40875 V
Installation kit for UP20 F	40248 R
Installation kit for UP20 T	39501 T
Installation kit for: UP25 F/25NV F/28 F/33 F/33NV F/39 F/45 F and UP28-SVS	39476 X
Installation kit for UP25 T/28 T/33 T/39 T/45T	39501 T
Installation kit for UP28 R/33 R/39 R/45 R	39500 R
Nylon round flange for X57	70666 E
Nylon square flange for X64	70670 V
Chrome plated cover ring - X68	40894 Z
Pump filling kit	40876 X

UC94-OBF OUTBOARD CYLINDER

Black bull horn mounting bracket	40877 Z
Through tube stainless steel rod	40174 M
Spacer kit	40878 B
Tiller arm connecting	42080 N

UC128-OBF OUTBOARD CYLINDER

Black bull horn mounting bracket	39490 R
Through tube stainless steel rod	39491 T
Spacer kit	41812 Z
Plastic cap kit	41810 V
UC128 Hardware kit	39979 A
Tiller arm connecting kit (ultrabolt)	40822 X

UC128-SVS OUTBOARD CYLINDER

Tiller arm connecting kit (ultrabolt)	42081 R
---------------------------------------	---------

UC132-OBS OUTBOARD CYLINDER

Stainless steel tilt tube extension	39495 B
Extension rod connecting pin	40917 J

INBOARD CYLINDERS

Balljoint for UC69-I	40883 U
Balljoint for UC116-I	39477 Z
Balljoint for UC168-I and UC215-I	39478 B
Balljoint for UC293-I	40178 W
Balljoint for UC378-I	41310 Y
Balljoint and shim for UC69-I	40884 W
Balljoint and shim for UC116-I	39479 D
Balljoint and shim for UC168-I e UC215-I	39480 M
Balljoint and shim for UC293-I	40180 G
Balljoint and shim for UC378-I	41311 A

STERNDRIVE CYLINDERS

Extension rod connecting pin	40917 J
------------------------------	---------

NUT AND SLEEVE

Brass nut and sleeve	71004 K
Nickel plated brass nut and sleeve	71013 L



UFLEX USA Inc.

6442 Parkland Drive
Sarasota, Florida 34243 - USA
P 941 351 2628 F 941 360 9171
www.uflexusa.com



ULTRAFLEX GROUP