



## UL 325

Standard to Which Vehicular Gate Operators are Manufactured and Tested

## ASTM F2200

Standard Specification for Automated Vehicular Gate Construction



### Important Safety Information

A moving gate or barrier arm, bollard, or wedge can cause serious injury or death. It is therefore incumbent on the site designer, installer, and property owner to ensure that these hazards are mitigated and the public is warned of the existence of a potential hazard. Read all the product safety information prior to installation. Verify the gate operator is installed to comply with all safety standards and local and federal regulations and is designated for its proper usage class. For more information, refer to your gate operator's product manual.

Information presented by:



Alex Wright, Sales & Marketing

877-816-7304

[alex.wright@totalsecuritywarehouse.com](mailto:alex.wright@totalsecuritywarehouse.com)



**Index**

Important Notices .....3  
WARNING .....4

What is UL .....5  
What is a UL Standard .....5  
What is the UL 325 Standard .....6  
Overview of UL 325 and Gates .....6  
UL 325 Time Line .....7  
Required Entrapment Protection Provisions Per UL 325 .....8  
Pre-2016 UL 325 Requirements .....8  
Post-2016 UL 325 Requirements .....9  
UL 325 Classifications .....11  
Specific Changes to UL 325 in 2016 .....12  
Know How to Comply to 2016 Changes in UL 325 .....15

ASTM F2200 Standard for Gate Construction .....16  
Installation Requirements per ASTM F2200 .....16

Instructions Regarding Intended Installation .....27

Safety Information for Slide Gate Operators ..... 30  
Slide Gate Requirements .....31  
Slide Gate External Entrapment Protection Devices .....33

Safety Information for Swing Gate Operators .....34  
Swing Gate Requirements .....35  
Swing Gate External Entrapment Protection Devices .....36

Safety Information for Barrier Gate Operators ..... 42  
Barrier Gate Requirements .....43

Why Should Installers Follow the UL Standard ..... 44  
How Will this Affect Dealers and Installers ..... 45  
Be Aware of Different Manufacture’s Interpretations of UL 325 Compliance .....46  
Where Else Can I Go to Educate Myself About Changes to 2016 UL 325 Standards .....46  
Automatic Gate Safety Checklist ..... 48

Frequently Asked Questions About UL 325-2016 .....50  
Glossary ..... 58



## **Important Notices**

Vehicular gate operator products provide convenience and security. However, gate operators must use high levels of force to move gates and most people underestimate the power of these systems and do not realize the potential hazards associated with an incorrectly designed or installed system. These hazards may include:

- Pinch points
- Entrapment areas
- Reach through hazards
- Absence of entrapment protection devices
- Improperly located access controls
- Absence of vehicle protection devices
- Absence of controlled pedestrian access

In addition to these potential hazards, automated vehicular gate systems must be installed in accordance with the UL 325 Safety Standard and the ASTM F2200 Construction Standard. Most lay persons are unaware of, or are not familiar with, these standards. If an automated vehicular gate system is not properly designed, installed, used and maintained, serious injuries or death can result. Be sure that the installer has instructed the end-user on the proper operation of the gate and gate operator system.

**Note:** Technical data sheets are information tools only and should not be used as substitutes for instructions from individual manufactures. Always consult with individual manufactures for specific recommendations for their products and check the applicable local regulations.



## **WARNING - To Reduce the Risk of Injury or Death**

Be sure that the installer has trained the end user about the basic functions of the required reversing systems associated with the gate operating system and how to test them. These include reversing loops, inherent reversing system, electric edges, photoelectric cells, or other external devices.

- Read and follow all instructions.
- The owner's manual is to be kept on-site. Keep it in a safe place for future reference.
- Always keep people and objects away from a gate. No one should cross the path of the moving gate. Pedestrians must use a separate entrance.
- Be sure that all access control devices are installed a minimum distance of 6' away from the gate and gate operator, or in such a way that a person cannot touch the gate or gate operator while using the device. If access control devices are installed in violation of these restrictions, immediately remove the gate operator from service and contact your installing dealer.
- Loops and loop detectors, photo-cells, or other equivalent devices, must be installed to prevent the gate from closing on vehicular traffic.
- The speed limit for vehicular traffic through the gate area is 5 mph. Install speed bumps and signs to keep vehicular traffic from speeding through the gate area. Failure to adhere to posted speed limits can result in damage to the gate, gate operator, and to the vehicle.
- Be sure that all persons who will use the gate system are familiar with the proper use of the gate and gate operator and are familiar with the possible hazards associated with the gate system.
- Be sure that warning signs are permanently installed on both sides of the gate in an area where they are fully visible to traffic.
- It is the end users responsibility to periodically check all entrapment protection devices. If any of these devices are observed to function improperly, remove the operator from service immediately and contact the installing or servicing dealer.
- Keep gates properly maintained. Read the owner's manual. Have a qualified service person make any repairs to gate hardware, access controls, or accessories.
- Follow the recommended maintenance schedule.
- Do not allow children to play in the area of the operator or to play with any gate-operating device.
- To remove the gate operator from service, operate the gate to the full open position and then shut off power to the operator at the service panel.
- Use the emergency release only when the gate is not moving.



## **What is UL**

UL provides safety-related certification, validation, testing, inspection, auditing, advising and training services to a wide range of clients, including manufacturers, retailers, policy makers, regulators, service companies, and consumers.

## **What is a UL Standard**

UL standards are voluntary standards that establish minimum requirements and are developed via an open, non-exclusionary process. "Voluntary" means that the standard has not been initiated through any government or similar regulatory agency mandate. "Minimum" means that the industry and those who developed the standard believe that the requirements should be met by all participants affected by the standard, and that more stringent provisions may be adopted by some in the industry. Finally, an "open, non-exclusionary process" indicates that any interested party can participate in the development of a UL standard. In addition, a number of UL standards have undergone a "canvass" (ballot) process in order to obtain recognition as American National Standards.



## **What is the UL 325 Standard**

The standard to which vehicular gate operators are manufactured and tested to is UL 325. In addition to the 325 standard, vehicular gate operators must also be tested to UL 991, which tests for Safety-Related Controls Employing Solid-State Devices.

These requirements cover electric operators for doors, draperies, gates, louvers, windows, exterior awnings and other opening and closing appliances rated 600V or less to be employed in ordinary locations in accordance with the National Electrical Code, NFPA 70. These requirements also cover complete doors, gates, and other such assemblies that include electric opening and closing appliances. Also covered are accessories, such as external entrapment protection devices, for use with appliances covered by this standard.

You should never install a vehicular gate operator that does not carry the “mark” of an NRTL (Nationally Recognized Testing Laboratory) such as ETL or UL. You should also be aware that NRTL’s do not “approve” or “certify” products that they test. Manufacturers that use this terminology are incorrect in its usage. When a product is tested by an NRTL, and that product is found to be in compliance with the safety standard, then that product is said to be “LISTED” and the manufacturer receives a “mark” and an “Authorization to Label” from the NRTL.

## **Overview of UL 325 and Gates**

- A glossary which defines each type of operator (slide, swing, vertical pivot, etc)
- Different “classes” of gate operators (Class I, II, III, IV)
- Entrapment\* protection criteria for each “class” of operator
- Entrapment\* alarm criteria
- Requirements for gate construction and installation (for detailed requirements regarding construction, see *ASTM F2200, Standard Specification for Automated Vehicular Gate Construction*)
- Instructional requirements placing increased responsibility on installers

\**Entrapment* is defined as “the condition when an object is caught or held in a position that increases the risk of injury.”

## UL 325 Time Line

The UL 325 Standard has undergone significant revisions over the past several years. The main purpose of the revisions were to create entrapment protection criteria for vehicular gate operators, and to increase overall safety of the product. The revised standard was first published September 18, 1998, and went into effect March 1, 2000. The key issues of the September 18, 1998 revision are as follows:

- Created different “classes” of vehicular gate operators
- Requires a primary and a secondary entrapment protection device (30A.1.1)
- Defined the different types of entrapment protection devices than can be used for primary and secondary protection in a given class of operator
- Requires an audio alarm to sound upon two sequential activations of an entrapment protection device not interrupted by an open or close limit device (30A.1.1A)
- Requires a renewed intended input in the line-of-sight of the operator once the entrapment sensing system detects a second sequential obstruction (30A.1.2b)
- Requires slide gates not to move greater than 1 ft/sec (30A.1.19)
- Requires the gate operator to have an integral means for manual operation (30A.1.20)

## From it's First Edition to Now

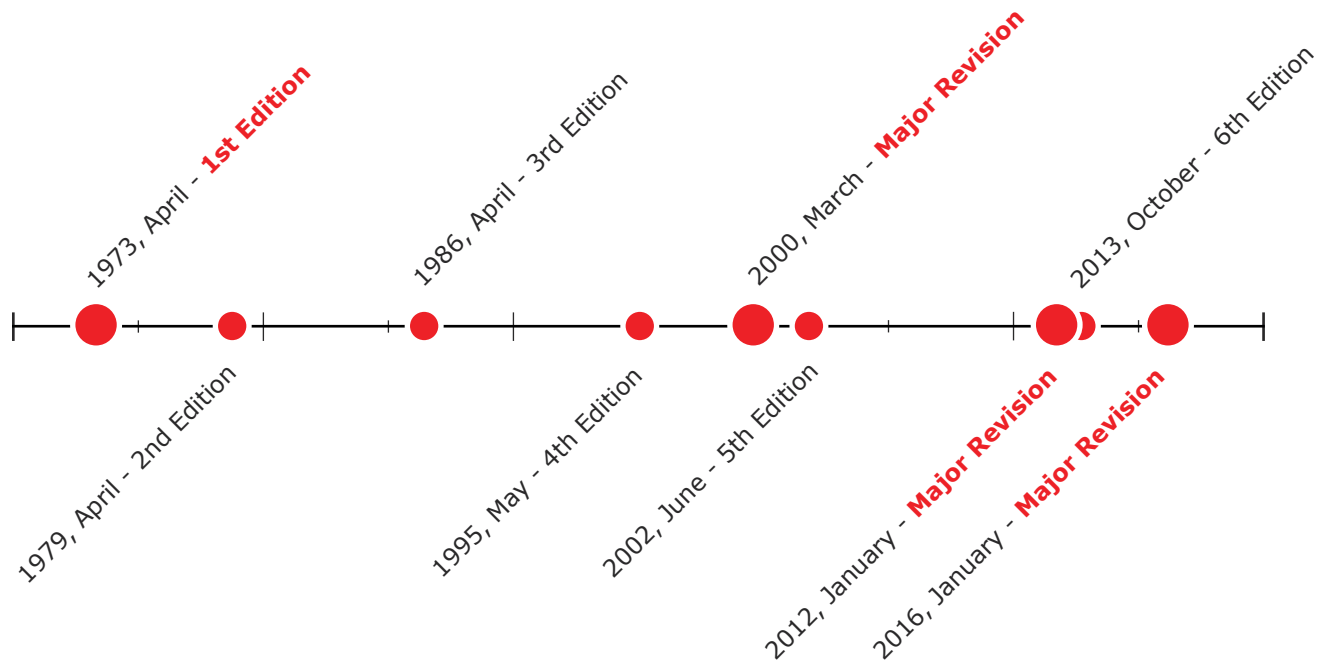



## Required Entrapment Protection Provisions Per UL 325

A key part of the UL 325 standard is a table (Table 31.1) that summarizes the entrapment device options for different classes of operators of the various types of gates included in the standard. Refer to the table as you read about the provisions that are described in the following sections.

### Pre-2016 UL 325 Requirements

UL 325 has always required two forms of entrapment protection be in place for every automatic gate installation. Those devices were described as “Primary” and “Secondary” entrapment protection devices. Depending on the usage class of the particular gate operator (industrial, commercial, or residential use), two different types of the entrapment protection devices were required to be installed.

Old Table 31.1

Usage Class	Horizontal Slide, Vertical Lift, and Vertical Pivot		Swing and Vertical Barrier (Arm)	
	Primary Type	Secondary Type	Primary Type	Secondary Type
Vehicular I and II	A	B1, B2, or D	A or C	A, B1, B2, C, or D
Vehicular III	A, B1, or B2	A, B1, B2, D, or E	A, B1, B2, or C	A, B1, B2, C, D, or E
Vehicular IV	A, B1, B2, or D	A, B1, B2, D, or E	A, B1, B2, C, or D	A, B1, B2, C, D, or E

**Type A** - Inherent entrapment protection system (typically built-in)

**Type B1** - Non-contact sensor (photoelectric sensor or the equivalent)

**Type B2** - Contact sensor (edge device or the equivalent)

**Type C** - Inherent force limiting, inherent adjustable clutch or inherent pressure relief device

**Type D** - Actuating device requiring continuous pressure to maintain opening or closing motion for the gate





## Post-2016 UL Changes

Changes in the UL 325 Standards that took effect on March 1, 2016 required substantial redesigning and retesting by gate operator manufacturers. The primary intent of the new standards is to prevent entrapment of persons in automated gate systems, as well as preventing injuries from pinch points. The new standards do not affect gate systems installed before the standards took effect; in other words, it is not retroactive.

A vehicular gate operator or vehicular barrier (arm) operator has always had to have provisions for, or be supplied, with at least two independent entrapment protection means. At installation, both entrapment protection devices must be installed. Typically, the first means is the Inherent Entrapment Sensor, built into almost all gate operators. The revision to UL 325, now effective, specifically addresses the 2nd entrapment protection means, and the requirement that all external entrapment protection sensors must be monitored for presence and correct operation.

**New Table 31.1**

Horizontal Slide, Vertical Lift, and Vertical Pivot	Swing and Vertical Barrier (Arm)
Entrapment protection types: A, B1*, B2*, D	Entrapment protection types: A, B1*, B2*, C, or D
<p>Note: The same type of device shall not be utilized for both entrapment protection means. Use of a single device to cover both the opening and closing directions is in accordance with the requirement; however, a single device is not required to cover both directions. A combination of one Type B1 for one direction and one Type B2 for the other direction is the equivalent of one device for the purpose of complying with the requirements of either entrapment protection means.</p>	

**Type A** - Inherent entrapment protection system (typically built-in)

**Type B1** - Non-contact sensor (photoelectric sensor or the equivalent)

**Type B2** - Contact sensor (edge device or the equivalent)

**Type C** - Inherent force limiting, inherent adjustable clutch or inherent pressure relief device

**Type D** - Actuating device requiring continuous pressure to maintain opening or closing motion for the gate

\*Type B1 and B2 must be monitored

The terminology "secondary" has been removed from describing the "primary" and "secondary" entrapment protection devices that are required. This was done to clarify the assumption that one device was more important than the other.



## Post-2016 UL Changes *(continued)*

Only entrapment protection devices that have been tested, and approved, with a specific manufacture's model, can be used as a approved UL device. Manufactures publish up-to-date lists of their tested and approved photo eyes and edge sensors often.

All gate operators require two means of entrapment protection in each direction of travel. At least two means are required for each entrapment zone. The requirement for external monitored entrapment protection sensors extends to slide, swing, vertical lift, and vertical pivot gate operators. Barrier arm operators are exempt when an arm does not move within 16" of a rigid object.

Most gate operators won't automatically cycle unless you have installed at least one, and typically two, entrapment protection sensors. When entrapment protection devices are absent, or have failed, the gate will not operate.

### Additional Changes to Table 31.1

- Removed Class of Gates (I, II, III, and IV)
- Removed Type E (alarm) as entrapment protection option
- Provision for Usage Class 4 - Usage Class 4 sites must have a guard house or CCTV gate monitoring to verify credentials of vehicles entering or exiting the facility, and to ensure safe gate operation in the rare occurrence where pedestrians may be present.

## UL 325 Classifications



### Class I - Residential Vehicular Gate Operator

A vehicular gate operator (or system) intended for use in garages or parking areas associated with a residence of one-to four single families.

*Reworded to clarify wording. WAS: A vehicular gate operator (or system) intended for use in a home of one-to-four single family dwelling, or a garage, or parking area associated therewith.*



### Class II - Commercial/General Access Vehicular Gate Operator

A vehicular gate operator (or system) intended for use in a commercial location or building such as a multi-family housing unit (five or more single family units), hotel, garages, retail store, or other buildings accessible by or servicing the general public.

*Change: Now includes "accessible by" as another considerations.*



### Class III - Industrial/Limited Access Gate Operator

A vehicular gate operator (or system) intended for use in an industrial location or building such as a factory or loading dock area or other locations not accessible by or intended to service the general public.

*Change: Now includes "not accessible by" as another consideration.*



### Class IV - Restricted Access Vehicular Gate Operator

A vehicular gate operator (or system) intended for use in a guarded industrial location or building such as an airport security area or other restricted access locations not servicing the general public, in which unauthorized access is prevented via supervision by security personnel.

*No change.*

## Specific Changes Effective January 12, 2016

**25.11, 31.1.7, Table 31.1** - Revision to require the same level of evaluation for Types B1 and B2 devices when used as the primary or secondary entrapment protection for gate operators. The outputs for gate operators using B1 and B2 protection for primary and secondary entrapment protection are both required to be monitored.

**3.4, 3.11, 3.19, 25.11, 31.1.1, Table 31.1, 31.1.2, 31.1.6, 31.1.7, 31.1.15, 31.2.1.1, 31.2.1.2, 58.1.6** - Revision to remove reference to the terms "Primary" and "Secondary" when describing entrapment protection devices.

Removing Type E device (audio alarm entrapment protection device) as an option for gate operators. Review products to confirm no vehicular gate operator Class III and IV products are relying on Type E audio alarm entrapment protection.

Also, audio alert alarm now needed for all gate operators (previously only required for Class I and II). Review Class III and IV gate operators to ensure they now include audio alert alarm.

**58.8.4 items a) 2), item f) and exception** - Revisions to instructions for gate operators regarding screening or guarding of horizontal slide gates, to align with ASTM F2200. Also, revised instructions for controls for emergency access.

**31.1.1** - A vehicular gate operator or vehicular barrier (arm) operator shall have provisions for (see 61.3.5), or be supplied with, at least two independent entrapment protection means as specified in Table 31.1. At installation, both entrapment protection devices must be installed.

### Monitored External Devices

**31.1.7** - A gate operator installed in accordance with the manufacturer's instructions utilizing external entrapment protection designated Types B1 or B2 in Table 31.1 to comply with 31.1.1 by having provision for connection of such device, or providing such device with the operator, shall monitor for the presence and correct operation of the device at least once during each open and close cycle. Should the device not be present, or a fault condition occur that precludes the sensing of an obstruction, including an interruption of the wireless signal to the wireless device or an open or short circuit in the wiring that connects the external entrapment device to the operator and the device's supply source, the operator shall function as required by 31.1.17.

**Note:** When external devices (B1 B2) are used, all external devices used for entrapment protection now need to be monitored (Par. 31.1.7). Previously, only the Primary needed to be monitored, so the secondary was not required to be monitored.



### Audio Alerts

Now, all gate operators shall have audio alarm when constructed as indicated. Previously, only Class I and II needed this.

**31.1.2** - A vehicular gate operator or vehicular barrier (arm) operator shall be supplied with an audio alarm complying with 31.1.3 and 31.1.4. The alarm shall signal upon two sequential activations of an entrapment protection device, **where the first activation is either a Type A or B2 device and the second activation is a Type A device**. The alarm shall signal for a minimum of 5 minutes or until a renewed manual input from an integral control or a permanently mounted control located in the line-of-sight of the gate has been entered.

**Note:** Only needed when noted as highlighted above.

Type B1 External Entrapment Protection Device (non-contact) - revision regarding permissible gate action.

**31.1.6** - A gate operator utilizing entrapment protection designated Type B1 in Table 31.1 by having provision for connection of, or providing with the operator, a non-contact sensor (photoelectric sensor or equivalent) to comply with 31.1.1 shall, upon sensing an obstruction in the direction of travel of the gate:

- a) Stop or reverse the gate within a maximum of 2 seconds.
- b) Stop the gate, or stop and initiate reversal of the gate upon sensing a second sequential obstruction in the opposite direction while in the process of reversal as described in **(a)**.

**58.8.4 items a) 2), item f) and exception** - Revisions to instructions for gate operators regarding screening or guarding of horizontal slide gates, to align with ASTM F2200. Also, revised instructions for controls for emergency access.

Horizontal gate operator instructions screening up to 6' high now required (to align with ASTM F2200). Install the gate operator only when:

- 1) The operator is appropriate for the construction of the gate and the usage Class of the gate,
- 2) All openings of a horizontal slide gate are guarded or screened from the bottom of the gate to a minimum of 6' above the ground to prevent a 2 1/4" diameter sphere from passing through the openings anywhere in the gate, and in that portion of the adjacent fence that the gate covers in the open position (previously was 4').



## Specific Changes Effective January 12, 2016 (continued)

### Controls for Emergency Access Only

Instruction Requirements Revised;

**f)** Controls intended for user activation must be located at least 6' away from any moving part of the gate and where the user is prevented from reaching over, under, around, or through the gate to operate the controls.

**Exception:** Emergency access controls only accessible by authorized personnel (e.g. fire, police, EMS) may be placed at any location in the line-of-sight of the gate.

### Type C Entrapment Protection Means

Clarifications made;

**31.1.13** - A swing gate operator utilizing entrapment protection designated Type C in Table 31.1 to comply with 31.1.1 shall, upon sensing an obstruction in any direction, stop the gate and:

**a)** Not result in a force after 100,000 cycles of operation under rated load of more than 10 percent higher than the initial setting to stop the gate. When adjustable, the initial setting is to be at the setting for maximum force, and

**b)** Inherent pressure relief devices and inherent adjustable clutches shall be readily accessible for inspection and repair and not readily rendered inoperative.

**31.2.1.1** - When Types A, B2, or C entrapment protection devices are used as the primary or secondary entrapment protection provisions, a gate operator shall, upon contact with the obstruction specified in 31.2.2 - 31.2.4:

**a)** For Types A or B2 provisions, initiate reversal of the moving gate within 2 seconds. The gate operator shall reverse the gate a minimum of 2" unless a control is actuated or an entrapment circuit senses an obstruction to stop the gate during its reversal, or

**b)** For Type C provision, not open or close the gate with a sustained force greater than 40 lb (177.9N) at the leading edge of the gate, except for the first 10 degrees of arc travel after any initiation of movement or a 2 second maximum time after any initiation of movement. If the force of the Type C device can be adjusted during use, user maintenance or installation, the Type C device is to be adjusted to the maximum setting. The measurement is to be made at the minimum length of the gate recommended by the manufacturer, at least 2 seconds after contact.



## **Know How to Comply to 2016 Changes in UL 325**

Swing and slide gate operators manufactured on or after January 12th, 2016 will only function with a constant push input, unless connected to one or more “monitored” external entrapment protection sensors. An exception may be a swing gate that was tested and approved with a Type C (clutch or pressure relief valve) that limits the force to 40# maximum at the free end of the gate.

Gate operator manufacturers have chosen one of three compliance technologies in the design of their new UL 325 compliant control boards:

- Normally Closed Photo Eye and Edge Sensor
- Pulse/Frequency Detection
- Resistance Detection (10K)

At a minimum, installers must wire at least one, and typically two, external entrapment protection sensors for the gate operator to cycle automatically in both directions of travel. A list of tested and approved external entrapment protection sensors is published by the gate operator manufacturer. Refer to gate operator manufacturer installation instructions for approved devices and installation instructions. Installing one manufacturer’s authorized sensor on another manufacturer’s operator may not work and will make your install UL 325 non-compliant.

Swing gates and slide gates must have external sensors installed that protect against entrapment in BOTH directions of travel. The number and placement of external sensors is dependent on site conditions and gate type. In most cases, this requires a minimum of two (2) external entrapment protection sensors (photo eyes and/or edge sensors). Installations may require greater number of devices be installed than the minimum required by the UL Standard if multiple entrapment zones exist.



## **ASTM F2200 Standard for Gate Construction**

Vehicular gates should be constructed and installed in accordance with ASTM F2200; Standard Specification for Automated Vehicular Gate Construction.

**Notice:** Extensive safety information exists in the gate operator product manuals. Be aware and read all safety information, labels, and signage that is shipped with your gate operator to ensure quality site design, and proper set up for functional gate operation and pedestrian safety.

## **Installation Requirements per ASTM F2200**

Prior to beginning the installation of the any automatic vehicular gate operator, we suggest that you become familiar with the instructions, illustrations, and wiring guidelines in this manual. This will help insure that your installation is performed in an efficient and professional manner compliant with UL 325 safety and ASTM F2200 construction standards.

The proper installation of the automatic vehicular gate operator is an extremely important and integral part of the overall access control system. Check all local building ordinances and building codes prior to installing any operator. Be sure your installation is in compliance with local codes.



**Para 4.2 - Gate Fall Over;** Gates shall be designed, constructed and installed to not fall over more than 45 degrees from the vertical plane, when a gate is detached from the supporting hardware.

**Standard Cantilever Gate Panel**

**View from Side**

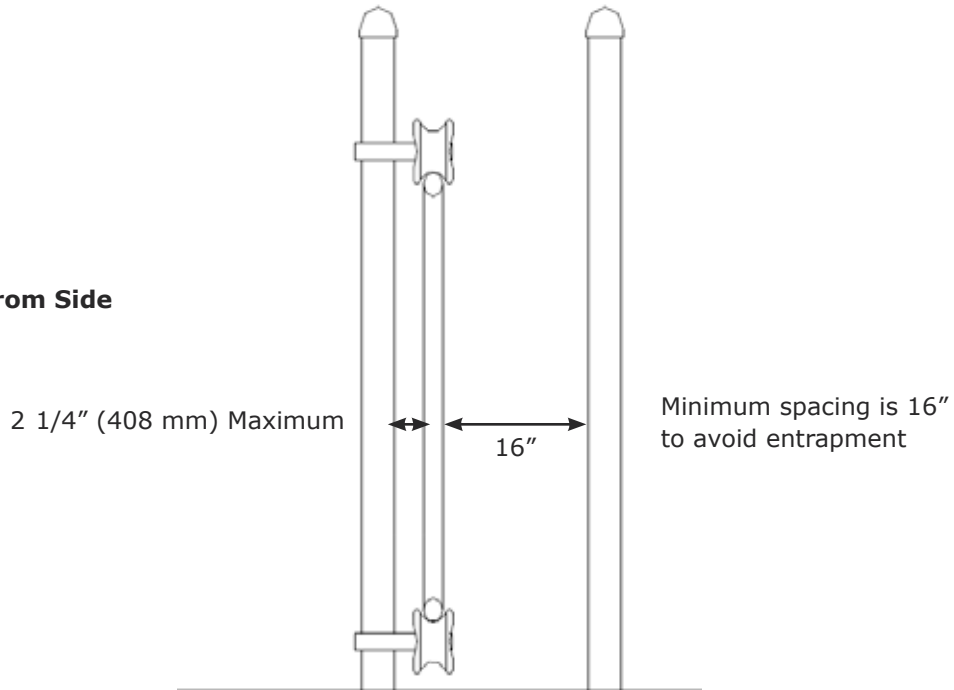

**Standard Cantilever Gate Panel**

**View from Side**

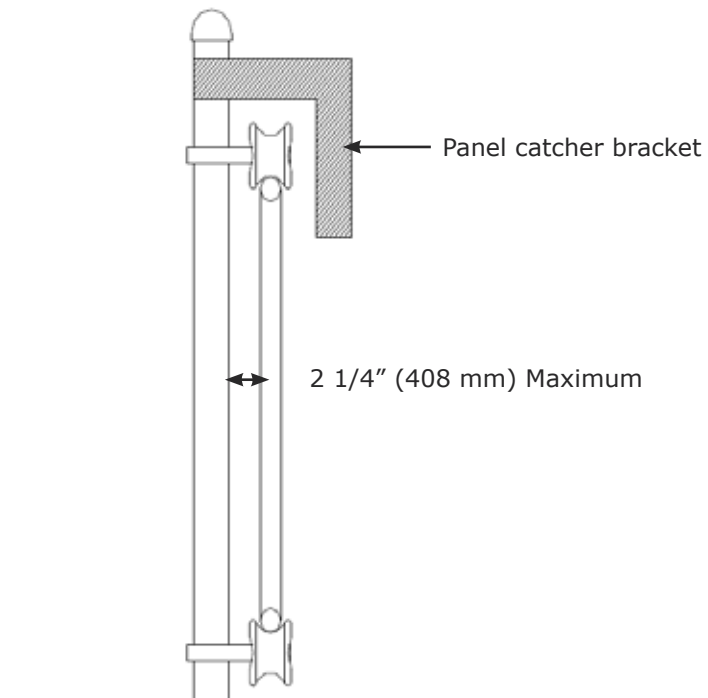

**Para 4.2 - Gate Fall Over;** (continued) Gates shall be designed, constructed and installed to not fall over more than 45 degrees from the vertical plane, when a gate is detached from the supporting hardware.

**V-Track Rolling Gate Panel**

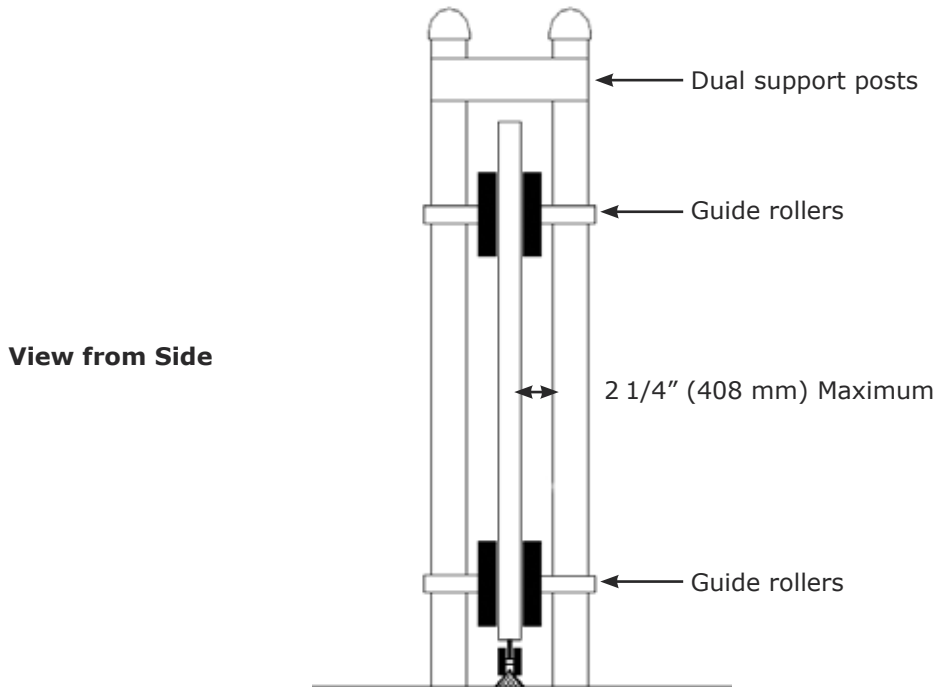

**Para 4.3 - Bottom Edge;** Gates shall have smooth bottom edges, with vertical bottom edged protrusions not exceeding 1/2" (12.7 mm) when other than exceptions listed in 4.8 (hardware, fasteners, bolts, etc are not considered protrusions as long as the do not protrude more than 1/2" and smooth on all surfaces. Safety devices in general are not protrusions).

**Slide Gate**

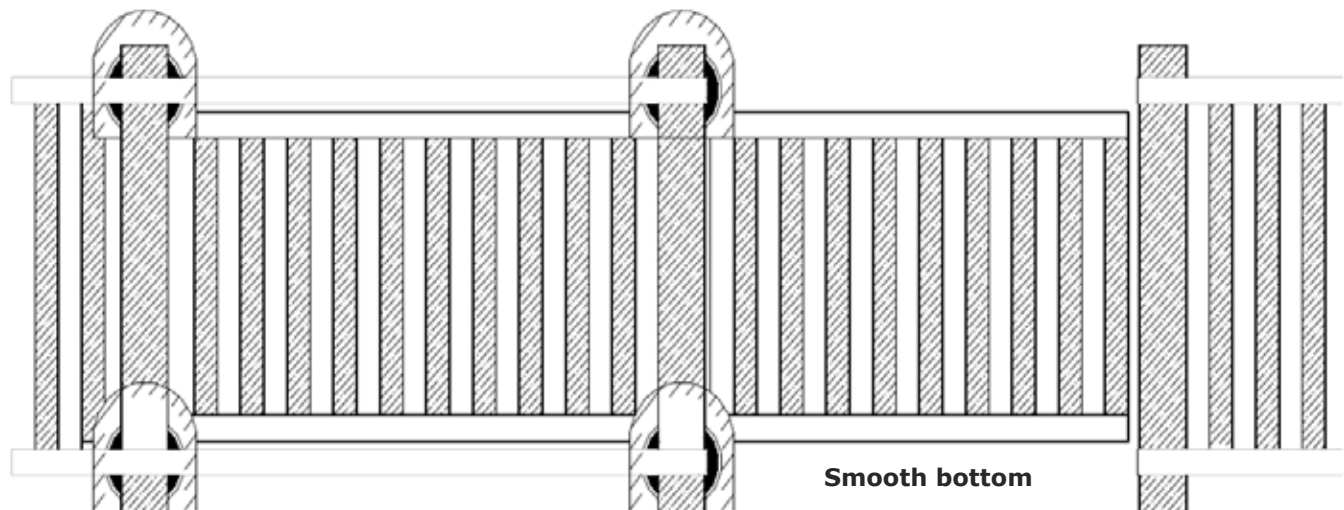

**Para 4.4 & 4.5 - Minimum Height;** The minimum height for barbed tape shall not be less than 8' (2.44 mm) above grade. The minimum height for barb wire shall not be less than 6' (1.83 mm) above grade.

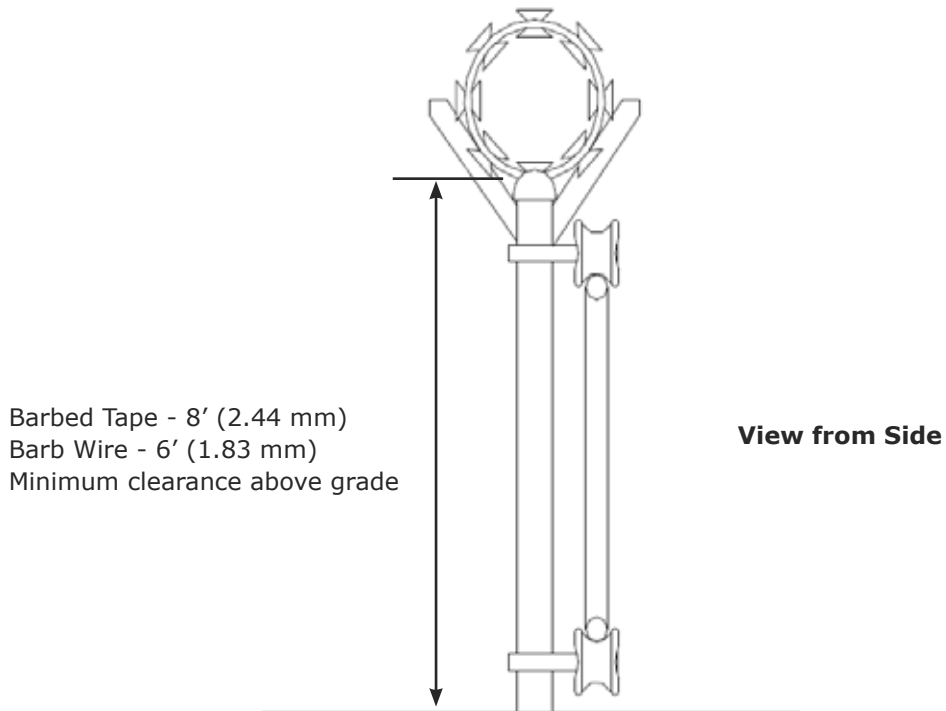

**Para 4.8.3 - Gate Edge Protrusions;** Protrusions at the leading and trailing vertical gate edges shall not exceed 1/2" (12.7 mm), and shall be smooth on all surfaces with no sharp edges.

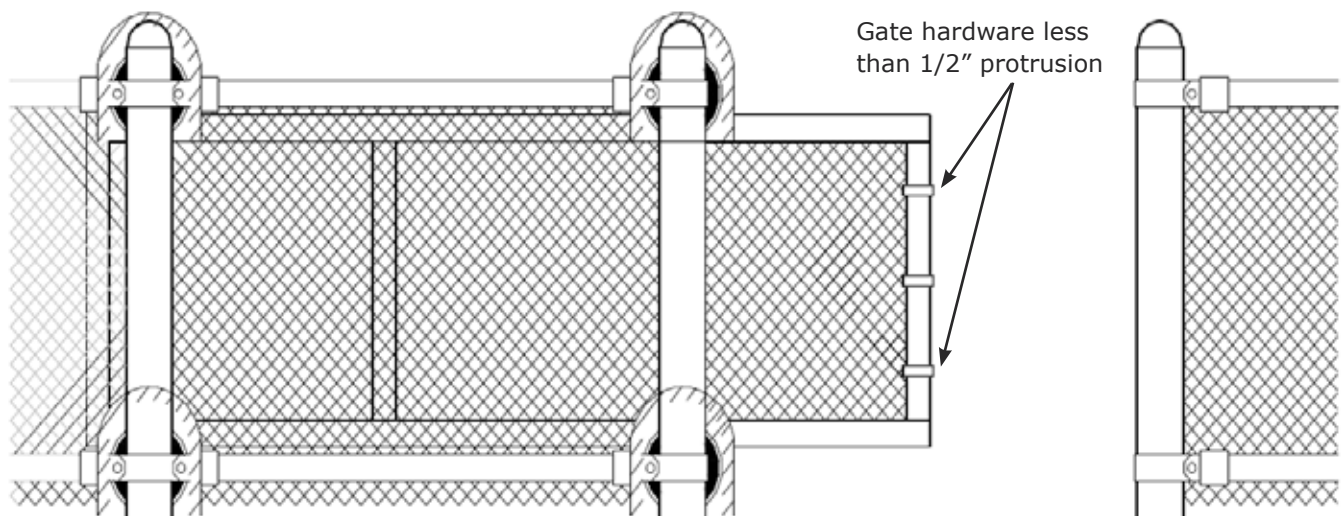

**Para 6.1.1 - Guards/Covers;** All weight bearing exposed rollers 8' (2.44 m), or less, above grade shall be guarded or covered.

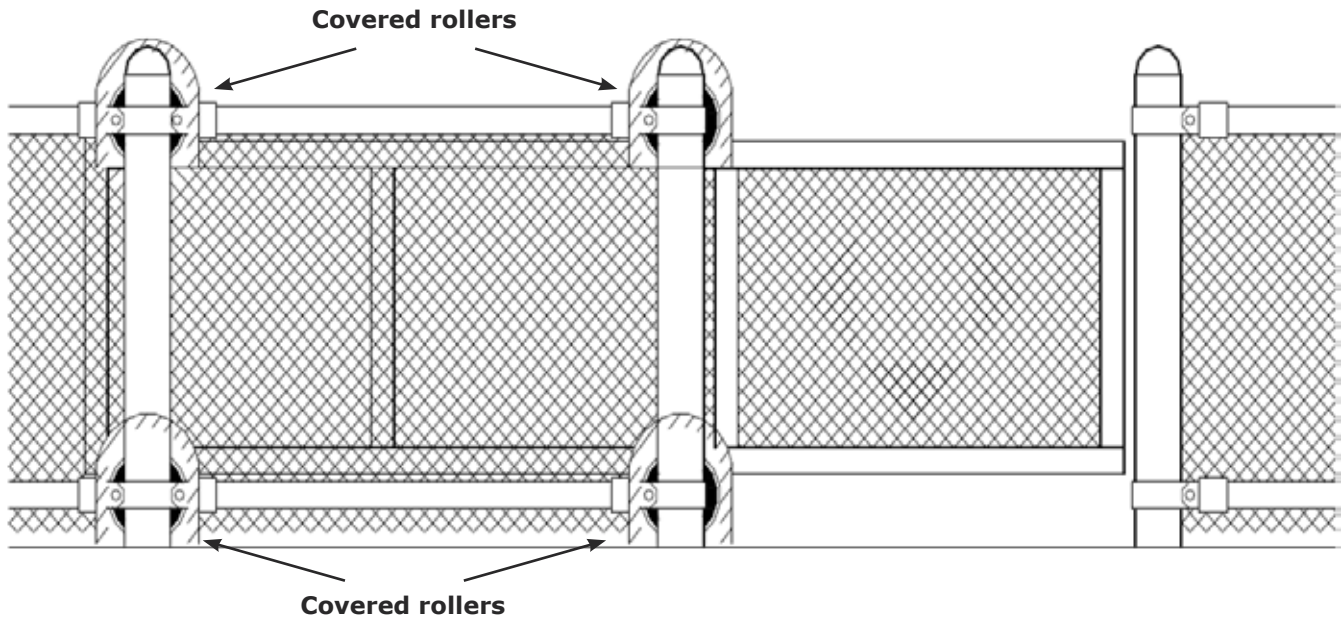

**Para 6.1.2 - Screening;** All openings shall be designed, guarded or screened from the bottom of the gate to the top of the gate or a minimum of 72" (1.83 m) above grade, whichever is less, to prevent a 2 1/4" (57 mm) diameter sphere from passing through the openings anywhere in the gate, and in that portion of the adjacent fence that the gate covers in the open position.

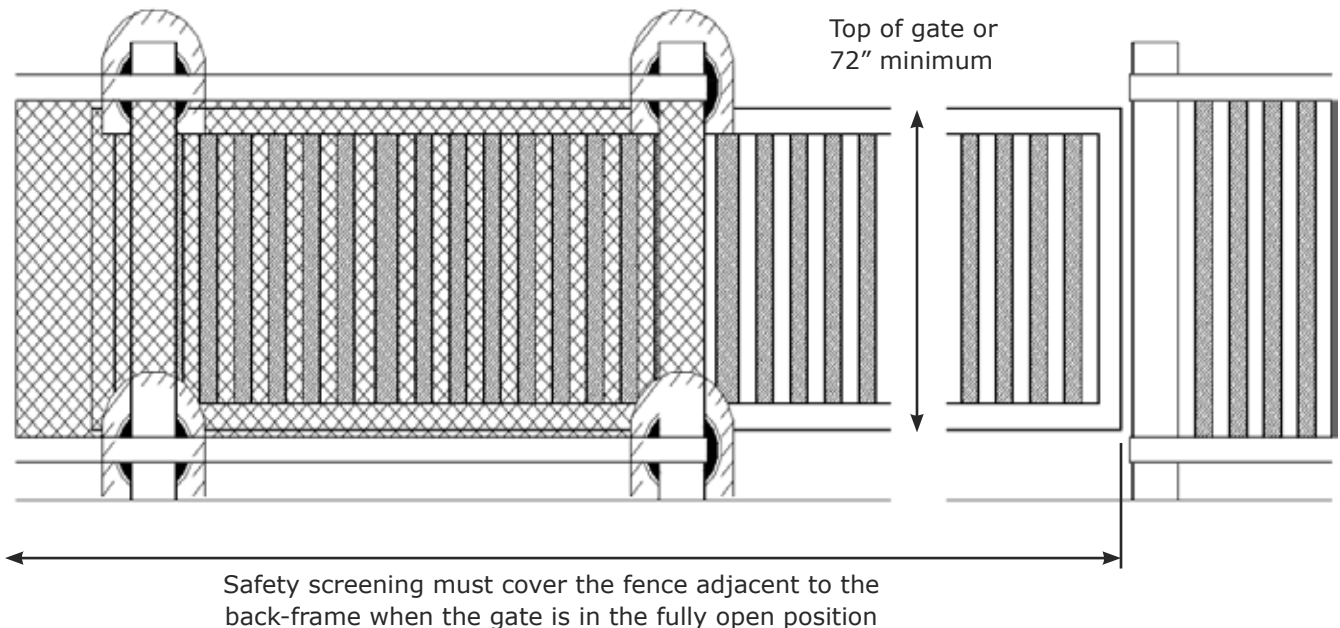

**Para 6.1.4 - Maximum Gap;** A gap, measured in the horizontal plane parallel to the roadway, between a fixed stationary object nearest the roadway (such as a gate support post) and the gate frame when the gate is in either the fully open or the fully closed position, shall not exceed 2 1/4" (57 mm).

**Exception:** All other fixed stationary objects greater than 16" (406 mm) from the gate frame shall not be required to comply with this section

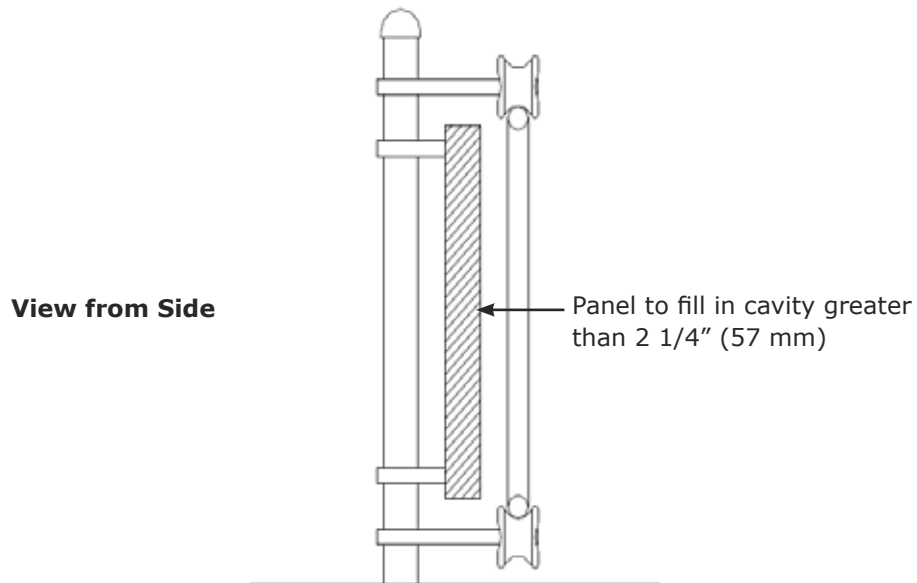

**Para 6.1.5 - Positive Stops;** Positive stops shall be required to limit travel to the designed fully open and fully closed positions.

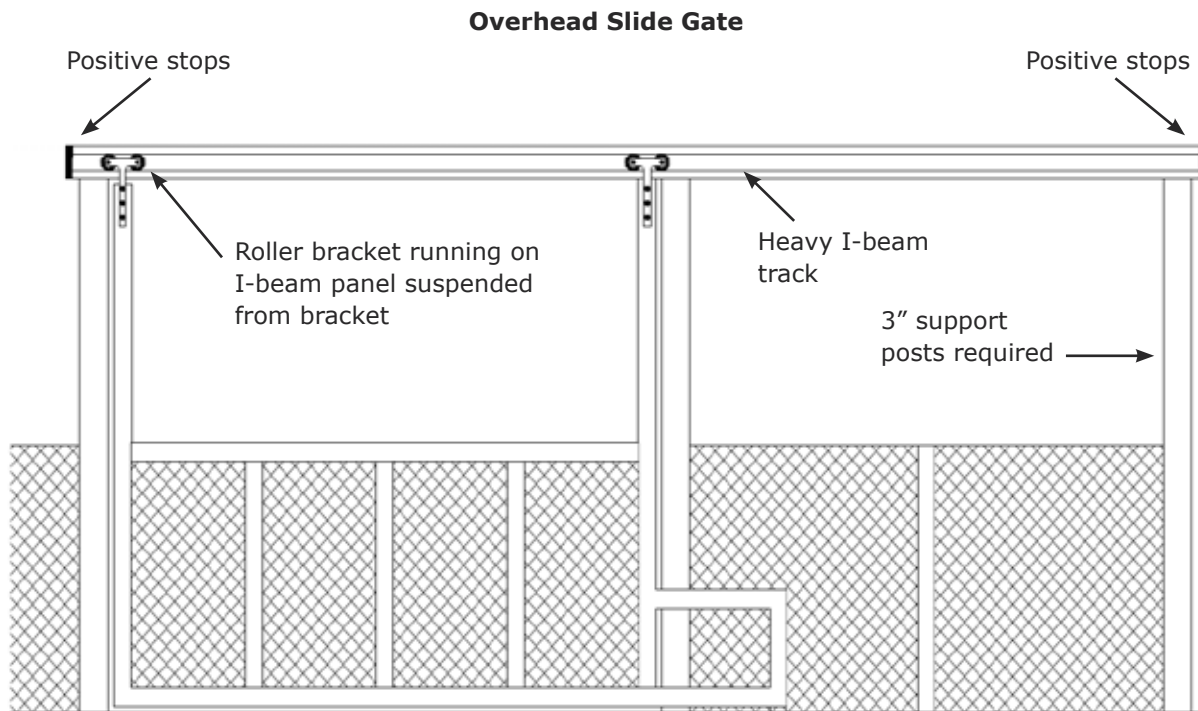

Weight of gate is suspended from the overhead beam. Size of opening is not limited. If motorized, requires a 3" minimum back frame.



**Para 6.1.6.1 - Receiver Guide, Single Panel;** Receiver guides shall be recessed behind the leading edge of the receiver post or fixed object.

**Exception:** Receiver guides mounted greater than 8' (2.44 m) above grade shall not be required to comply with this section.

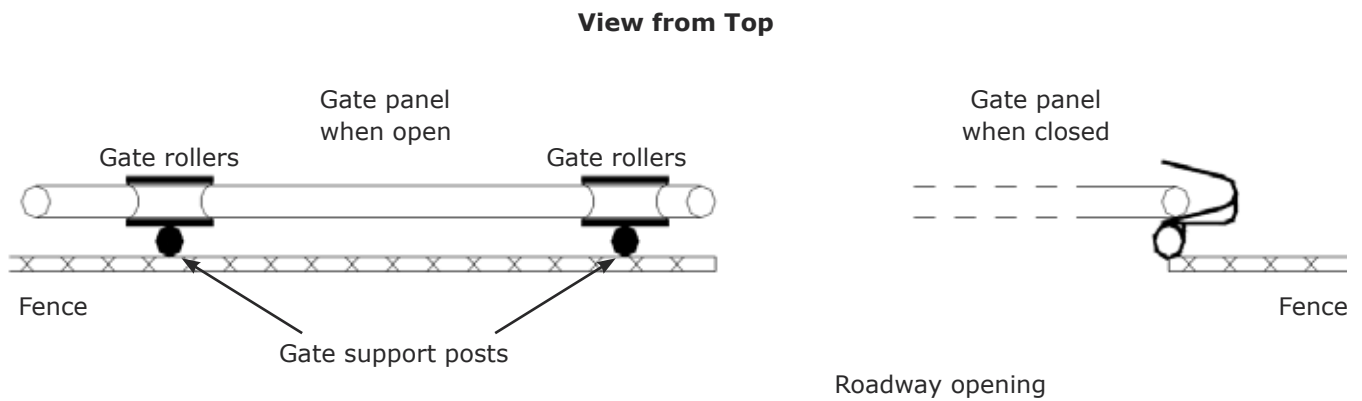

**Para 6.1.6.2 - Receiver Guide, Dual Panels;** Dual panel receiver guides, if used, may be installed on either panel and shall include a cross-sectional area of 9 in<sup>2</sup> (5806 mm<sup>2</sup>) or greater as measured on the leading edge of each guide.

**Exception:** Receiver guides mounted greater than 8' (2.44 m) above grade shall not be required to comply with this section.

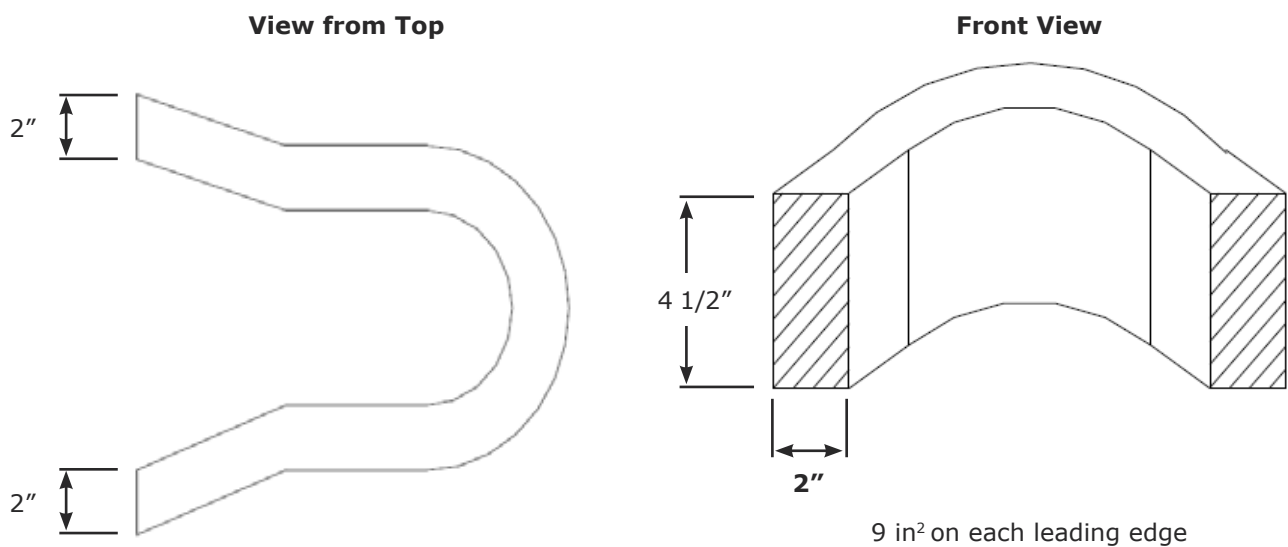

**Para 6.1.6.2 - Receiver Guide, Dual Panels;** (continued) Dual panel receiver guides, if used, may be installed on either panel and shall include a cross-sectional area of 9 in<sup>2</sup> (5806 mm<sup>2</sup>) or greater as measured on the leading edge of each guide.

**Exception:** Receiver guides mounted greater than 8' (2.44 m) above grade shall not be required to comply with this section.

**View from Top**

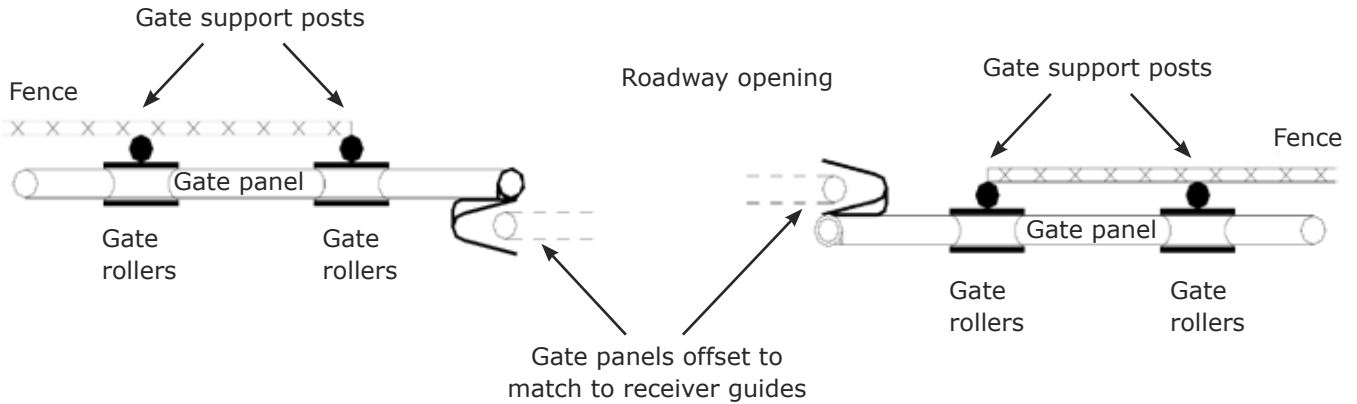

**Para 7.1.1.1 - Pivot Point;** The width of an object covered by a swing gate when in the open position shall not exceed 4" (102 mm), measured from the center line of the pivot point of the gate.

**View from Top**

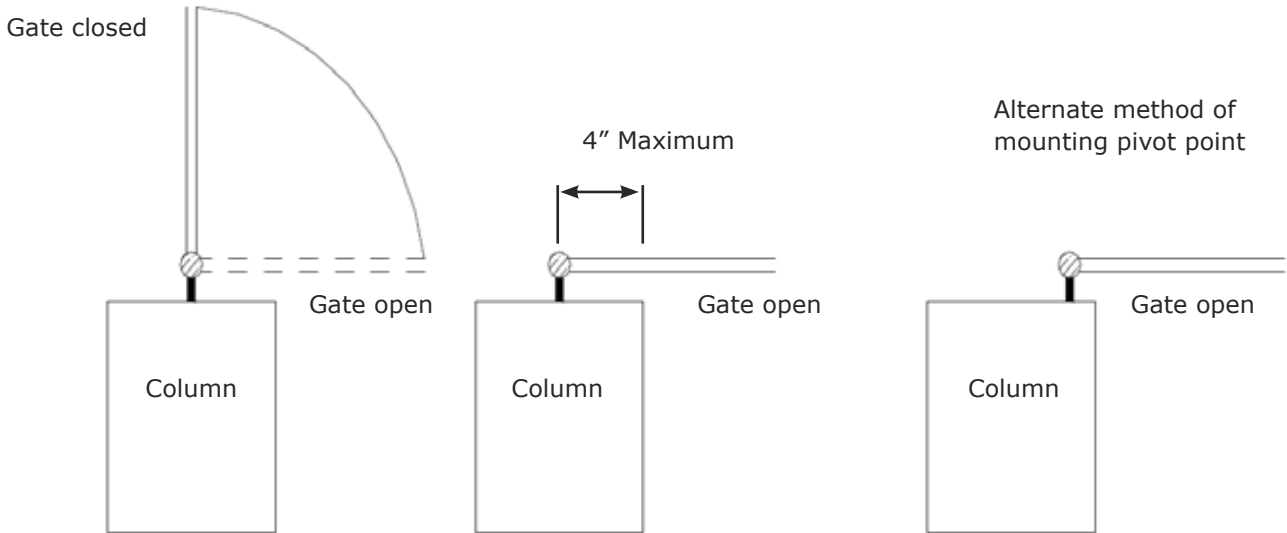

**Para 7.1.1.2 - Gate Clearance;** The distance between a fixed object such as a wall, pillar or column, and a swing gate when in the open position shall not be less than 16" (406 mm).

**Exception:** For a gate that is not in compliance with this provision, the defined area shall be subject to the entrapment protection provisions of UL 325.

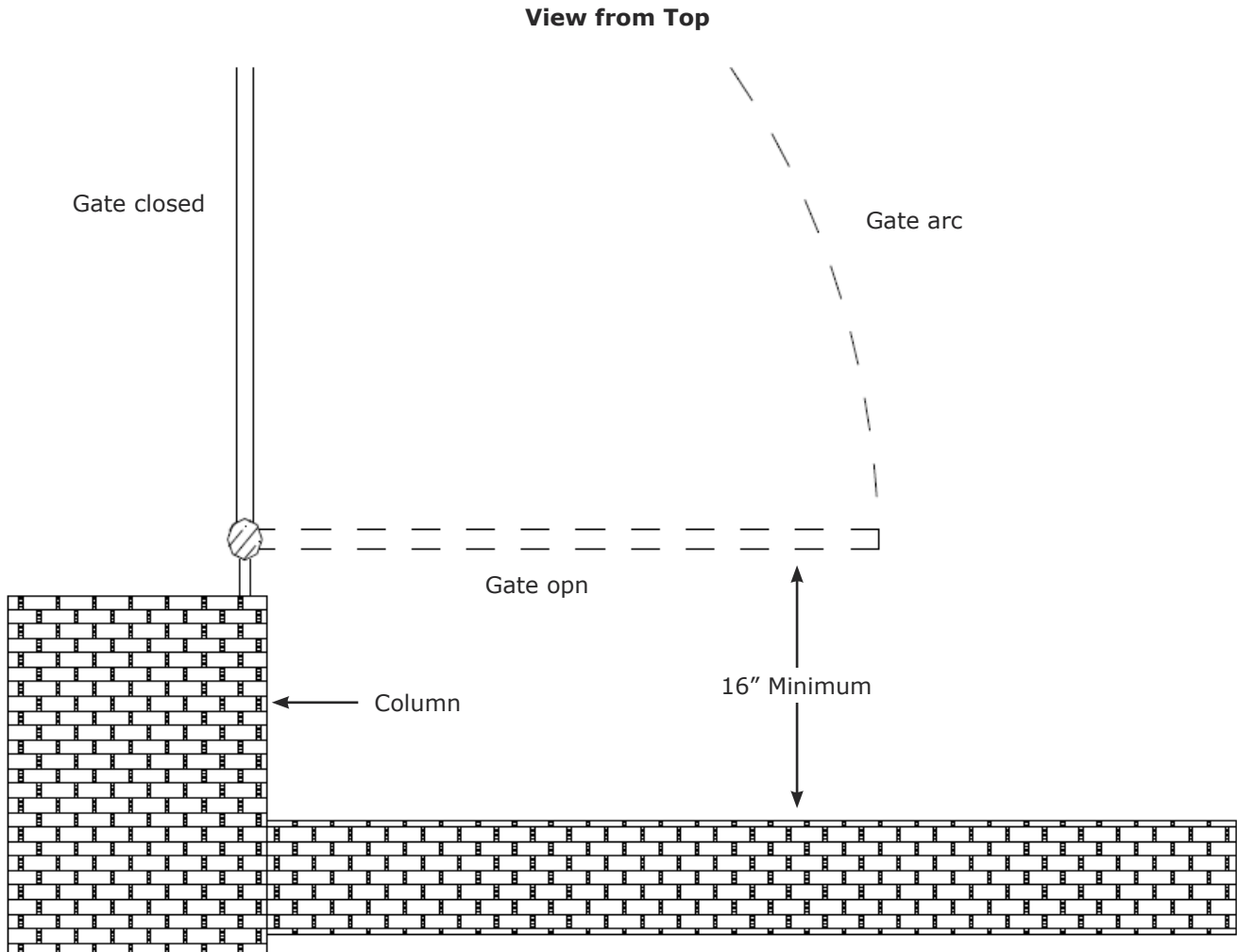



Para 8.1.1 and 8.1.4 - Screening, Positive Stops;

Vertical Lift Gate

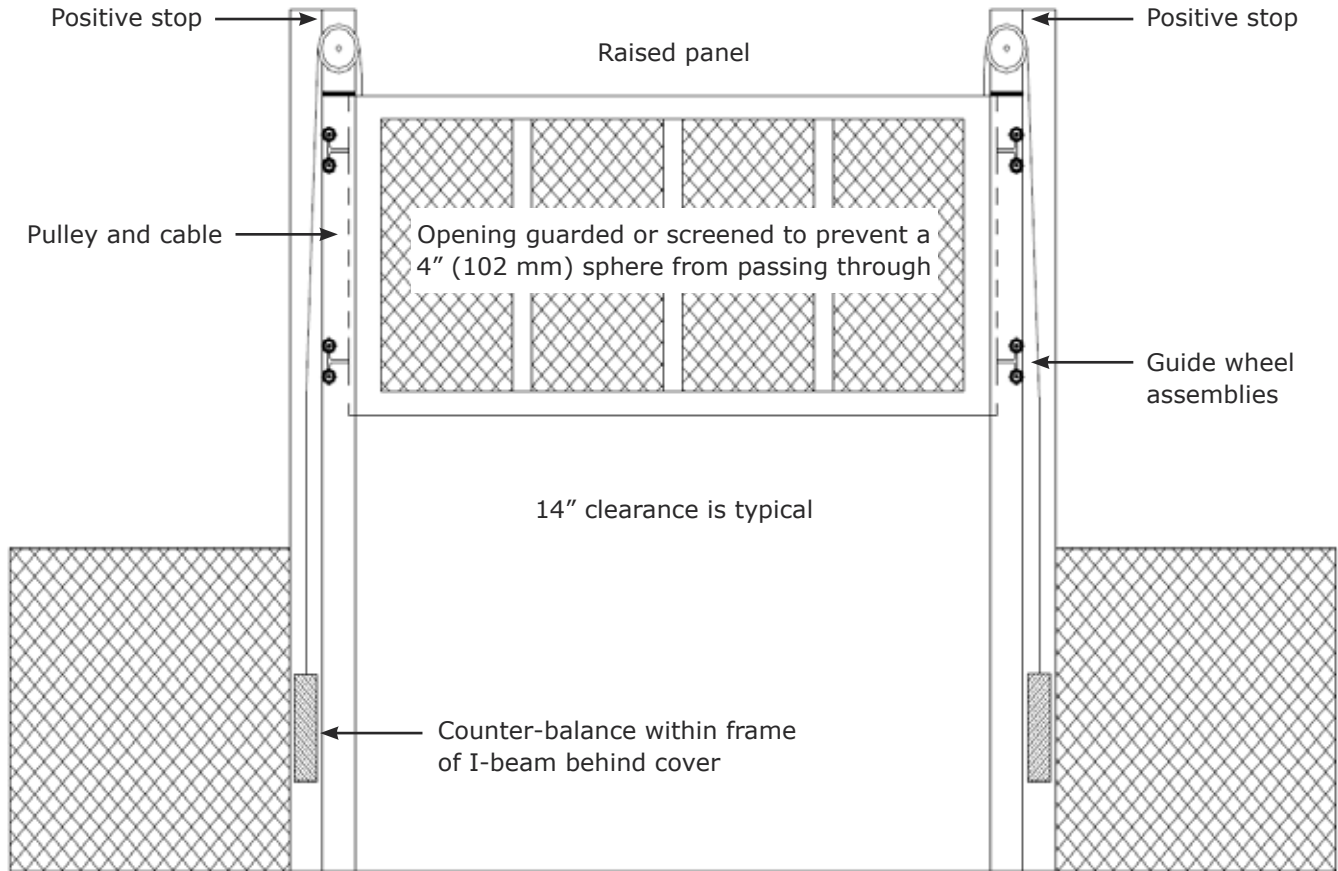

**Para 9.1.1 - Screening;** All areas of the moving gate panel from the bottom of the gate to the top of the gate or a minimum of 72" (1.83 m) above grade, whichever is less, that pass by a fixed stationary object, and in the area of the adjacent fence that the gate covers during the travel of the gate, shall be designed guarded, or screened to prevent a 2 1/4" (57 mm) diameter sphere from passing through such areas.

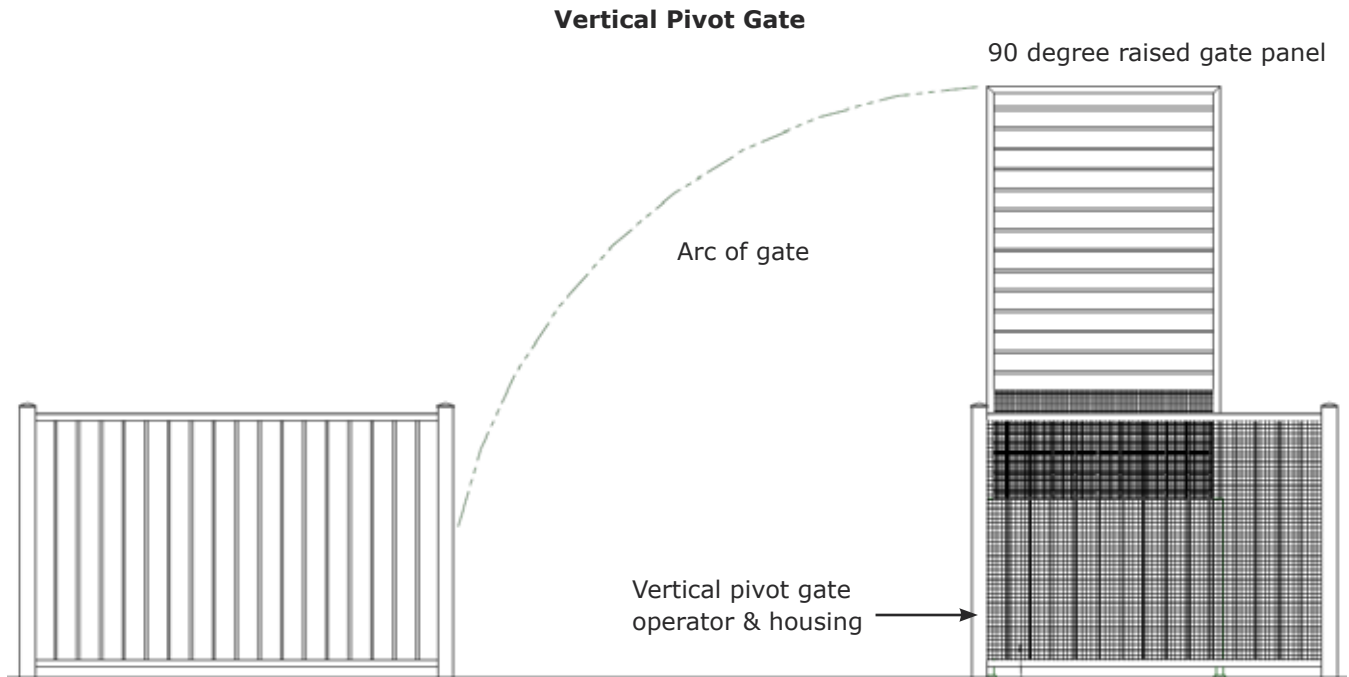

**Para 9.1.2 - Gap;** A gap, measured in the horizontal plane parallel to the roadway, between a fixed stationary object nearest the roadway (such as a gate operator) and the gate frame when the gate is in either the fully open position or the fully closed position, shall not exceed 4" (102 mm).

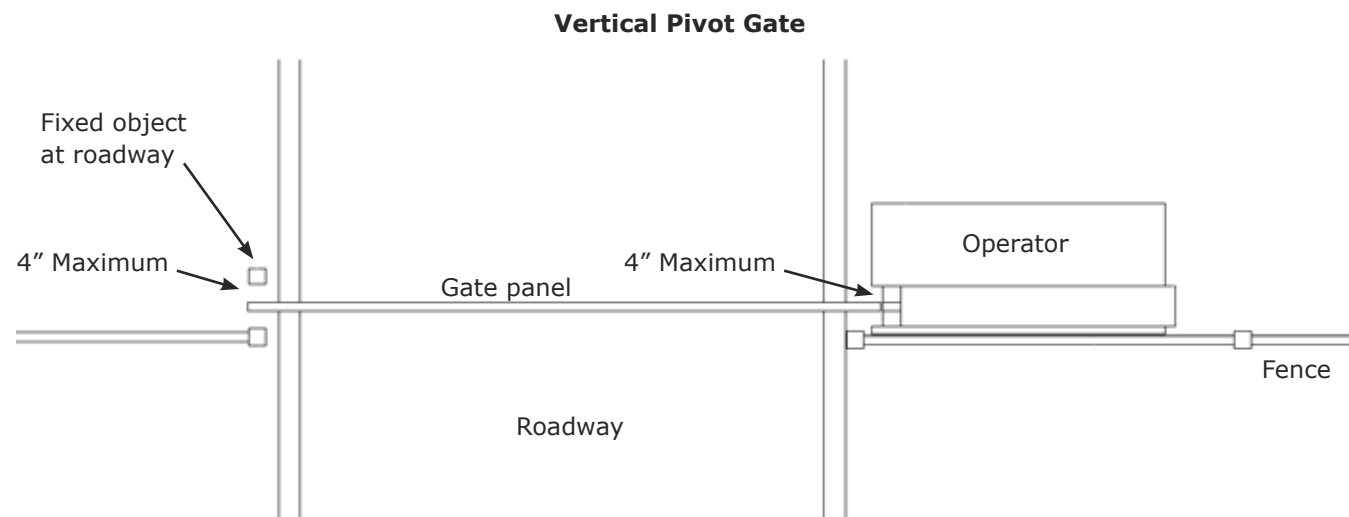



## Instructions Regarding Intended Installation

The operator is intended for installation only on gates used for vehicles. Pedestrians must be supplied with a separate access opening. The pedestrian access opening shall be designed to promote pedestrian usage. Locate the gate such that persons will not come in contact with the vehicular gate during the entire path of travel of the vehicular gate. A minimum of two (2) WARNING SIGNS shall be installed, one on each side of the gate where easily visible.

The gate must be installed in a location so that enough clearance is supplied between the gate and adjacent structures when opening and closing to reduce the risk of entrapment. Swinging gates should not open into public access areas.

The gate must be properly installed and work freely in both directions prior to the installation of the gate operator. Do not over-tighten the operator clutch, pressure relief valve or reduce reversing sensitivity to compensate for a damaged gate.

### Mount access control devices beyond reach of the gate. The control devices that operate the gate must:

- Be located in a clear line of sight to the gate. Locate controls (Open, Close, Stop/Reset) where a user will have a clear view of the gate.
- Be mounted beyond 6' (183 cm) of the moving gate to prevent users from touching or accessing the gate while operating the controls. People attempting to access the controls by reaching through or around the gate can be seriously injured or killed by the moving gate.

**Note:** An exception for Emergency Access Control (EAC) devices exists. An EAC device accessible by authorized personnel only (e.g. fire, police, EMS), may be placed at any location within the line-of-site.

### Install an automatic operator only on gates that comply with ASTM F2200 Gate and Fence Standards and the usage class of the gate. Screen or enclose openings in the gate per UL 325 Standards for Safety which include:

- All horizontal slide gates must guard or screen openings from the gate's base support to a minimum height of 6' (183 cm) above the ground. This must prevent a sphere of 2 1/4" (57 mm) in diameter from passing through an opening in the gate or the adjacent fence that is covered in the gate's open position.
- All exposed pinch points are eliminated or guarded.
- Physical stops must exist in the gate construction to prevent over-travel in both directions and, for slide gates, guide posts must be installed to prevent the gate from falling in the event of a roller failure. Guarding must be supplied for exposed rollers.
- External entrapment protection sensors must be used wherever the risk of entrapment exists.



## Instructions Regarding Intended Installation (continued)

### Install the gate operator only if:

1. The operator is appropriate for the construction of the gate and the usage class of the gate.
2. All openings of a horizontal slide gate are guarded or screened from the bottom of the gate to a minimum of 6' (1.83 m) above the ground to prevent a 2 1/4" (57.2 mm) diameter sphere from passing through the openings anywhere in the gate, and in that portion of the adjacent fence that the gate covers in the open position.
3. All exposed pinch points are eliminated or guarded.
4. Guarding is supplied for exposed rollers.

### For gate operators utilizing Type D protection:

1. The gate operator controls must be placed so that the user has full view of the gate area when the gate is moving.
2. A warning placard shall be placed adjacent to the controls.
3. An automatic closing device (such as a timer, loop sensor, or similar device) shall not be employed.
4. No other activation device shall be connected.

Controls intended for user activation must be located at least six feet (6') away from any moving part of the gate and where the user is prevented from reaching over, under, around or through the gate to operate the controls. Outdoor, or easily accessible controls, should have a security feature to prevent unauthorized use. The Stop and/or Reset button must be located in the line-of-sight of the gate. Activation of the reset control shall not cause the operator to start.

### For gate operators utilizing a non-contact sensor:

1. See the instructions on the placement of non-contact sensors in the following sections for each type of application.
2. Care shall be exercised to reduce the risk of nuisance tripping, such as when a vehicle trips the sensor while the gate is still moving in the opening direction.
3. One or more non-contact sensors shall be located where the risk of entrapment or obstruction exist, such as the perimeter reachable by a moving gate or barrier.



**For gate operators utilizing contact sensors:**

- 1.** One or more contact sensors shall be located where the risk of entrapment or obstruction exist, such as at the leading edge, trailing edge, and post mounted, both inside and outside, of a vehicular horizontal slide gate.
- 2.** One or more contact sensors shall be located at the bottom edge of a vehicular vertical lift gate.
- 3.** One or more contact sensors shall be located at the pinch point of a vehicular vertical pivot gate.
- 4.** A hardwired contact sensor shall be located and its wiring arranged so that the communication between the sensor and the gate operator is not subjected to mechanical damage.
- 5.** A wireless contact sensor such as one that transmits radio frequency (RF) signals to the gate operator for entrapment protection functions shall be located where the transmission of the signals are not obstructed or impeded by building structures, natural landscaping or similar obstructions. A wireless contact sensor shall function under the intended end-use conditions.
- 6.** One or more contact sensors shall be located at the bottom edge of a vertical barrier (arm).

**For gate operators utilizing a non-contact sensor:**

- 1.** See the instructions on the placement of non-contact sensors for each type of application.
- 2.** Care shall be exercised to reduce the risk of nuisance tripping, such as when a vehicle trips the sensor while the gate is still moving in the opening direction.
- 3.** One or more non-contact sensors shall be located where the risk of entrapment or obstruction exist, such as the perimeter reachable by a moving gate or barrier.

**For gate operators utilizing contact sensors:**

- 1.** One or more contact sensors shall be located where the risk of entrapment or obstruction exist, such as at the leading edge, trailing edge, and post mounted both inside and outside of a vehicular horizontal slide gate.
- 2.** One or more contact sensors shall be located at the bottom edge of a vehicular vertical lift gate.
- 3.** One or more contact sensors shall be located at the pinch point of a vehicular vertical pivot gate.
- 4.** A hardwired contact sensor shall be located and its wiring arranged so that the communication between the sensor and the gate operator is not subjected to mechanical damage.
- 5.** A wireless contact sensor such as one that transmits radio frequency (RF) signals to the gate operator for entrapment protection functions shall be located where the transmission of the signals are not obstructed or impeded by building structures, natural landscaping or similar obstructions. A wireless contact sensor shall function under the intended end-use conditions.
- 6.** One or more contact sensors shall be located at the bottom edge of a vertical barrier (arm).

## Safety Information for Slide Gate Operators

In addition to the inherent reversing sensor system, external entrapment protection MUST be installed or the operator will NOT function. Install these devices where the risk of entrapment or a safety hazard exists while the gate is moving. Specific installations will vary.

### Non-Contact Sensors (Photo Eyes)

- 1** Minimizes the potential of the gate closing on vehicular or other traffic that loops cannot sense. It can be installed on the secure or non-secure side of the gate
- 2** Helps minimize the potential of entrapment during the back travel of the gate

### Contact Sensor (Reversing Edges)

- A** Installed on the fence to help minimize the potential of entrapment between the gate and fence. A filler post or barrier may need to be installed between fence and gate
- B** Helps minimize the potential of entrapment during the back travel of the gate
- C** Minimizes the potential of the gate closing on vehicular or other traffic that loops cannot sense

### Physical Stops

Positive stops shall be required to limit travel to the designed fully open and fully closed positions. These stops shall be installed either at the top of the gate, or at the bottom of the gate where such stops shall horizontally or vertically project no more than is required to perform their intended function

### Screened Wire Mesh

May be necessary on part of fence and entire gate

### Warning Sign

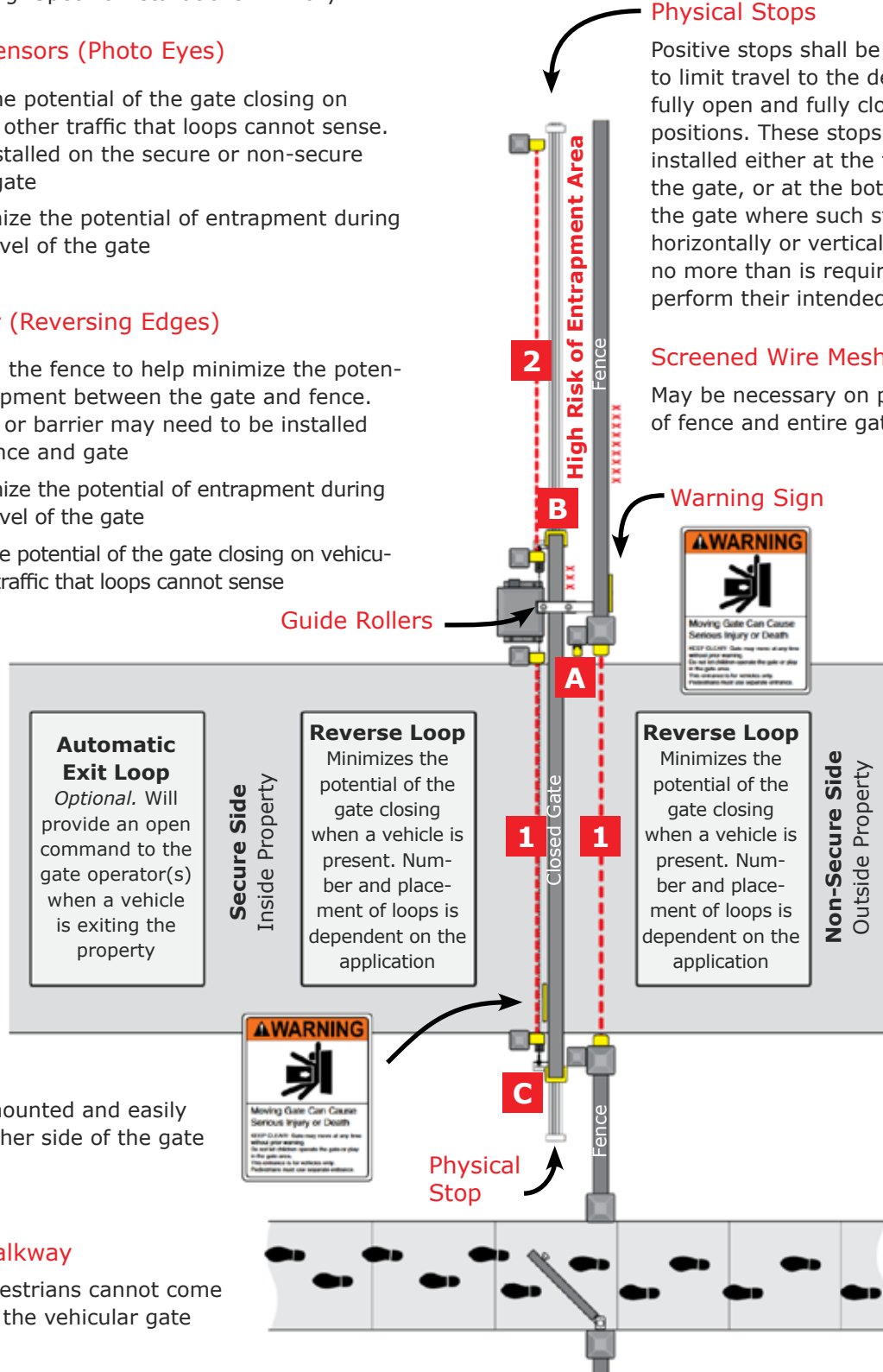

**Automatic Exit Loop**  
*Optional.* Will provide an open command to the gate operator(s) when a vehicle is exiting the property

**Reverse Loop**  
Minimizes the potential of the gate closing when a vehicle is present. Number and placement of loops is dependent on the application

**Reverse Loop**  
Minimizes the potential of the gate closing when a vehicle is present. Number and placement of loops is dependent on the application

### Warning Sign

Permanently mounted and easily visible from either side of the gate

### Separate Pedestrian Walkway

Located so pedestrians cannot come in contact with the vehicular gate

## Slide Gate Requirements

An automatic gate operator is intended for installation only on gates used for vehicles. Pedestrians must be supplied with a separate access opening. The pedestrian access opening shall be designed to promote pedestrian usage. Locate the gate such that persons will not come in contact with the vehicular gate during the entire path of travel of the vehicular gate.

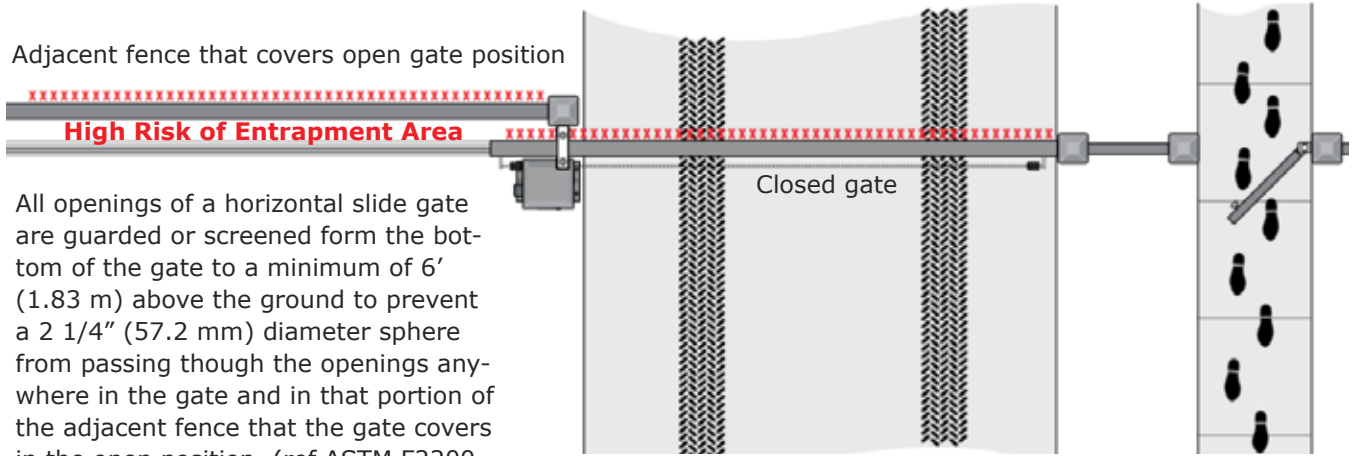

All openings of a horizontal slide gate are guarded or screened from the bottom of the gate to a minimum of 6' (1.83 m) above the ground to prevent a 2 1/4" (57.2 mm) diameter sphere from passing through the openings anywhere in the gate and in that portion of the adjacent fence that the gate covers in the open position. (ref ASTM F2200-11a, 6.1.2)

### Non-Compliant Openings

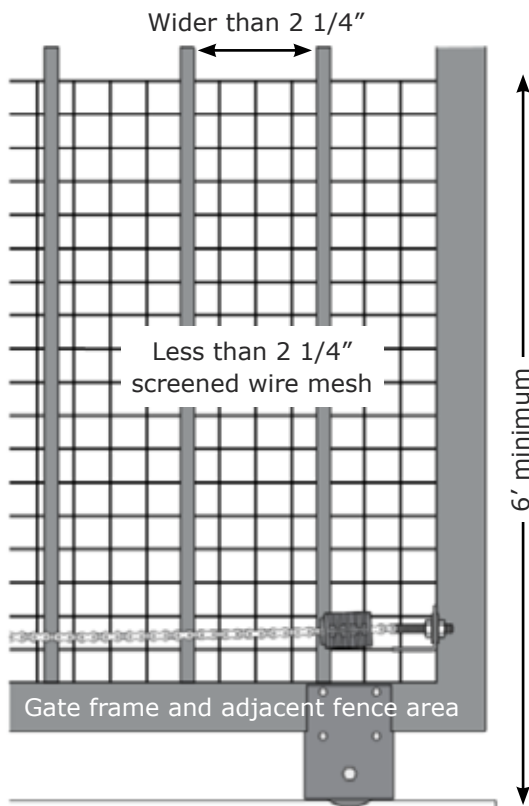

### Compliant Openings

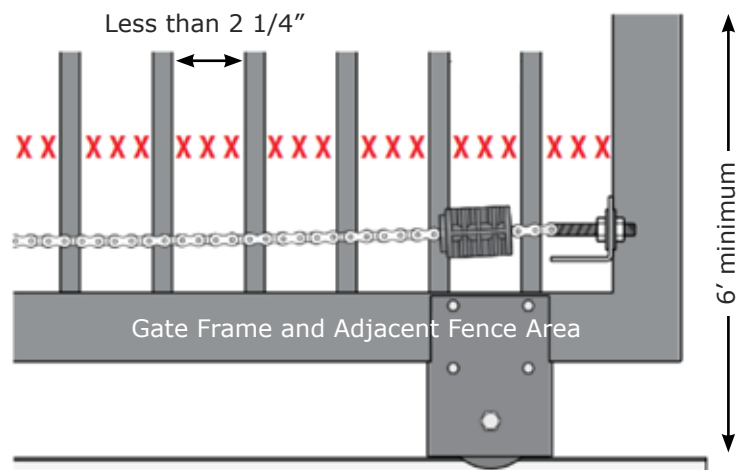

**Note:** Install screened wire mesh to a non-compliant gate AND non-compliant adjacent fence that covers open gate position (see above).

**Slide Gate Requirements** (continued)

**Fall Over Bracket**

Gates shall be designed, constructed and installed to not fall over more than 45 degrees from the vertical plane, when a gate is detached from the supporting hardware.

**Gate Frame & Support Post Gap**

A gap, measured in the horizontal plane parallel to the roadway, between a fixed stationary object nearest the roadway (such as a gate support post) and the gate frame when the gate is in either the fully open position or the fully closed position, shall not exceed 2 1/4" (57.2 mm). (ref ASTM F2200 6.1.4)

**Note:** A filler post or barrier may need to be installed in the gap area to reduce the distance to 2 1/4" or less. A contact sensor should be installed in this area for safety.





### Slide Gate External Entrapment Protection Devices

Typical Photo Sensor Mounting Height and Distance Away from Gate

If the Distance Between the Gate and Wall is Greater than 2 1/4"

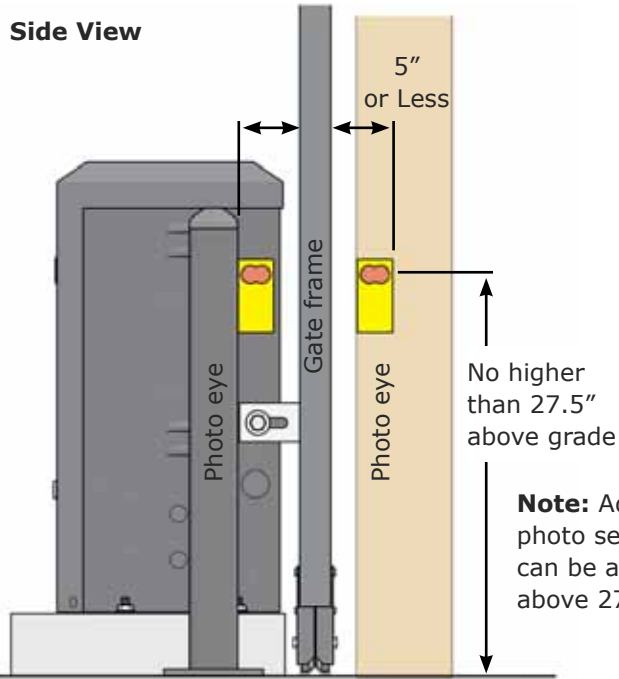
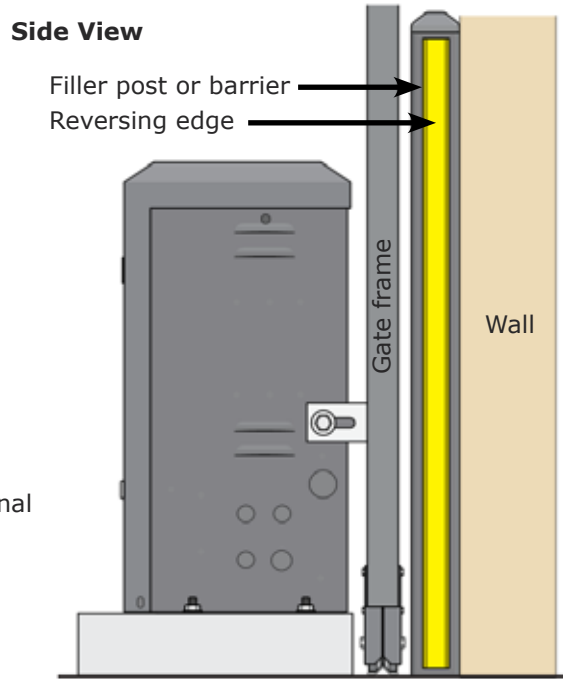
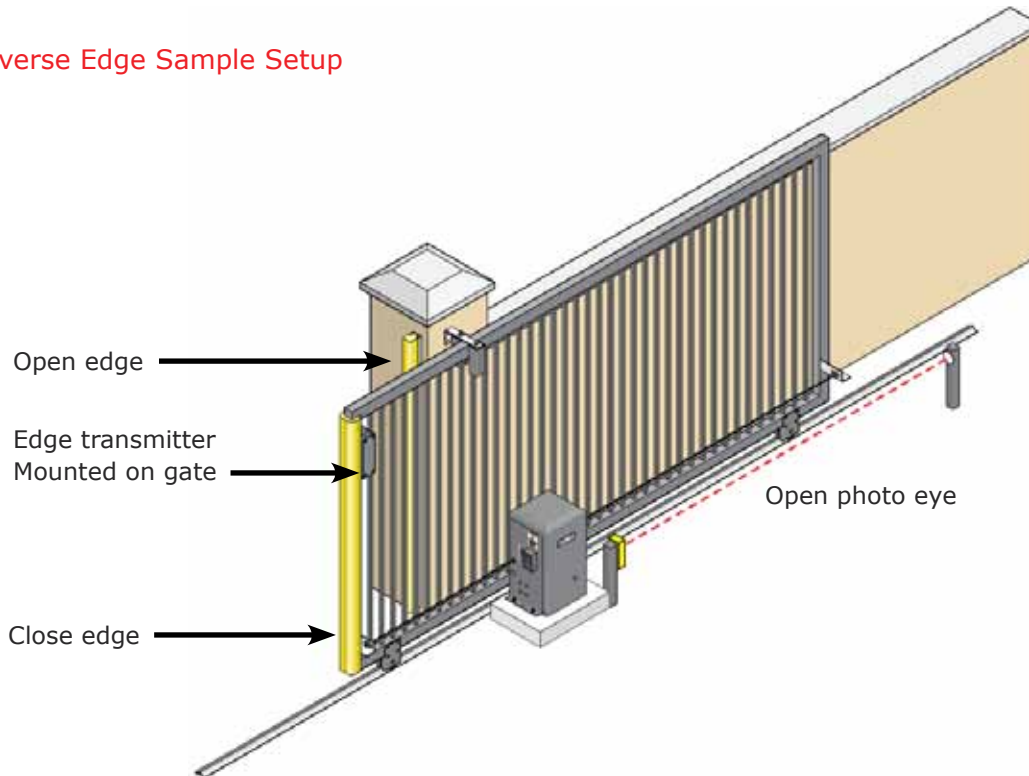

Photo sensors may be installed on either side of gate frame, as close as practical to the gate, but no further away than 5".



A filler post or barrier may need to be installed between the gate and wall area to reduce the distance to 2 1/4" or less. A reversing edge should be installed on the post or barrier for safety.

### Wireless Reverse Edge Sample Setup



## Safety Information for Swing Gate Operators

**C E** or **F** required for operator to function

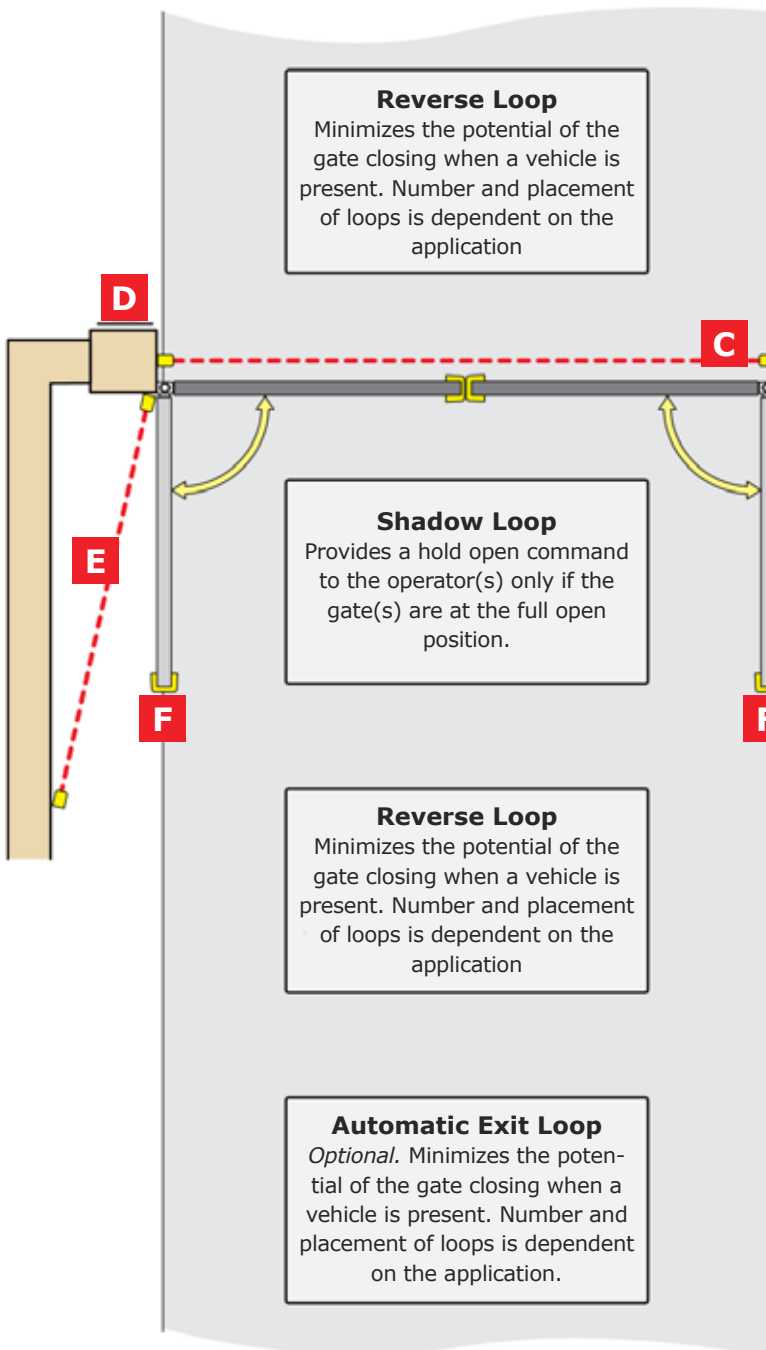

**C Non-Contact Sensors (Photo Sensors)**

Minimizes the potential of the gate closing on vehicular or other traffic that loops cannot sense.

**D Warning Signs**

Permanently mounted and easily visible from either side of the gate.

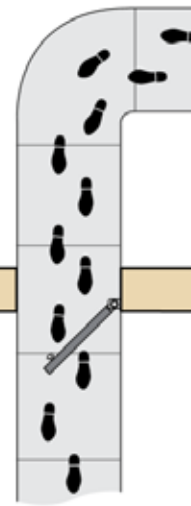

**Separate Pedestrian Walkway**

Located so pedestrians cannot come in contact with the vehicular gate.

**E Monitored Non-Contact Sensor**

Minimizes the potential of the gate striking vehicular or other traffic that loops cannot sense.

**F Contact Sensor**

Minimizes the potential of the gate striking vehicular or other traffic that loops cannot sense.

## Swing Gate Requirements

An automatic gate operator is intended for installation only on gates used for vehicles. Pedestrians must be supplied with a separate access opening. The pedestrian access opening shall be designed to promote pedestrian usage. Locate the gate such that persons will not come in contact with the vehicular gate during the entire path of travel of the vehicular gate.

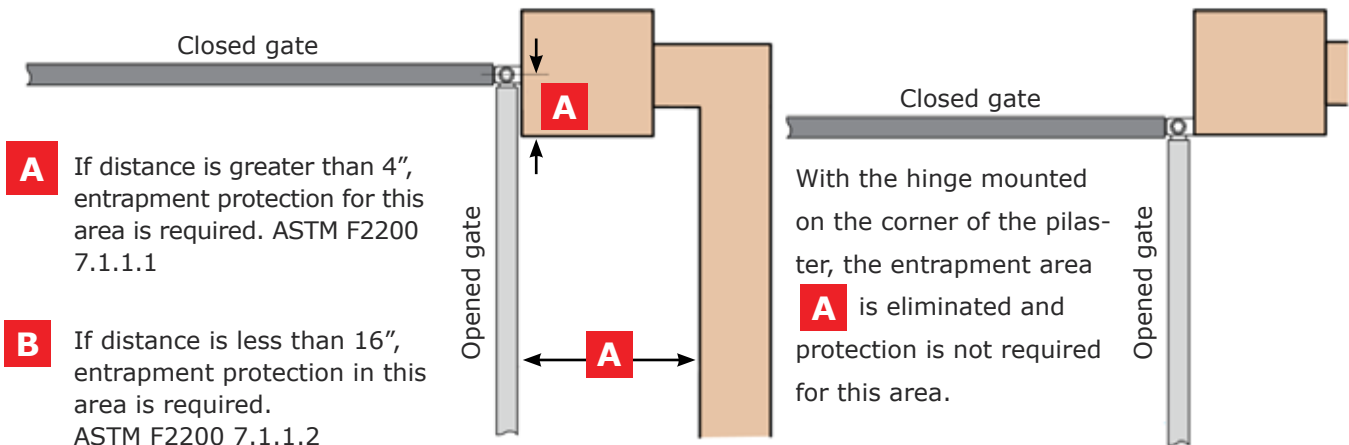
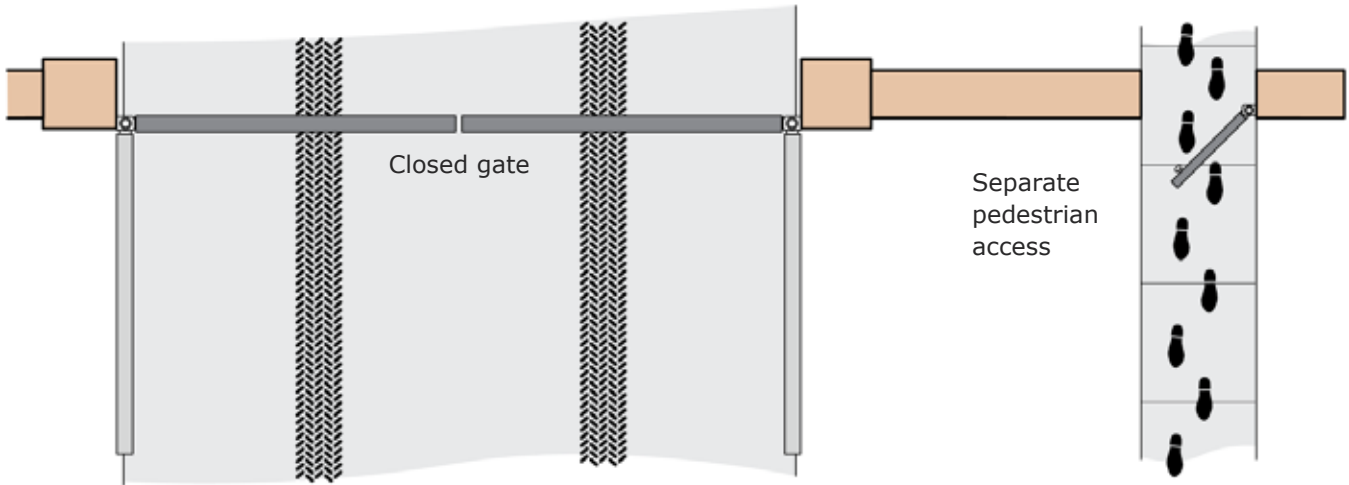

**BAD**

**GOOD**

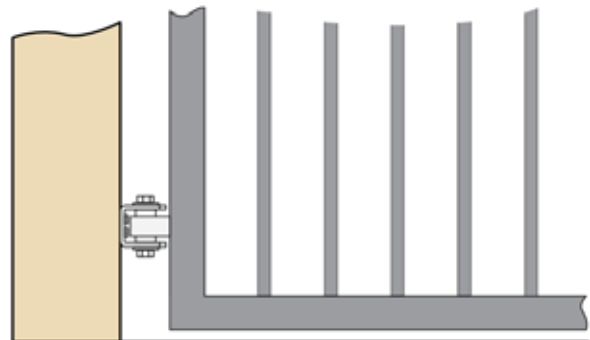
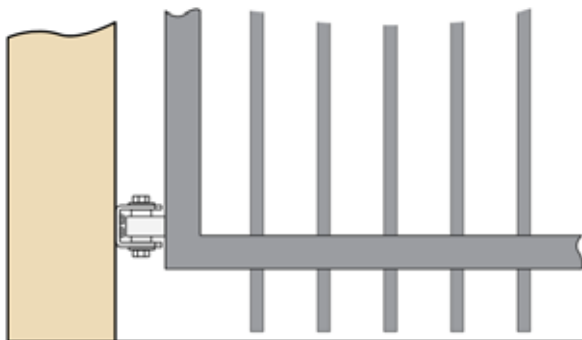

Gates shall have smooth bottom edges, with vertical bottom edged protrusions not exceeding 1/2". ASTM F2200 4.3

## Swing Gate External Entrapment Protection Devices

In addition to the inherent reversing sensor system, external entrapment protection **MUST** be installed or the operator will **NOT** function. Install these devices where the risk of entrapment or a safety hazard exists while the gate is moving. Specific installations will vary.

Close Photo Eye  
Side End View

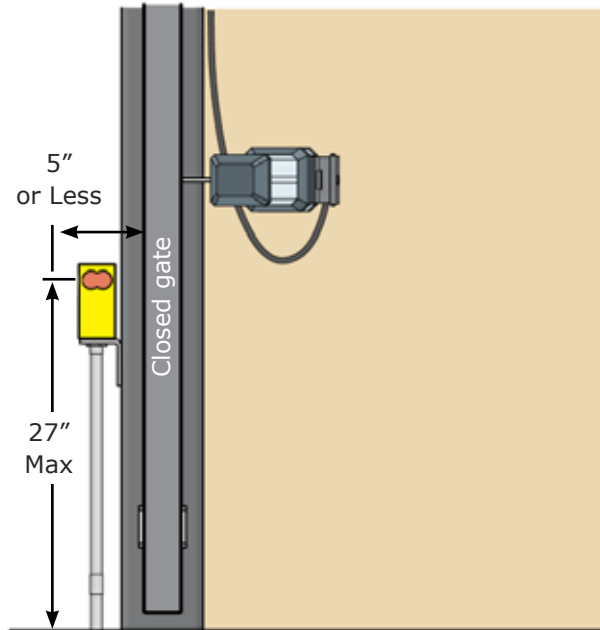

Open Photo Eye  
Secure Side View

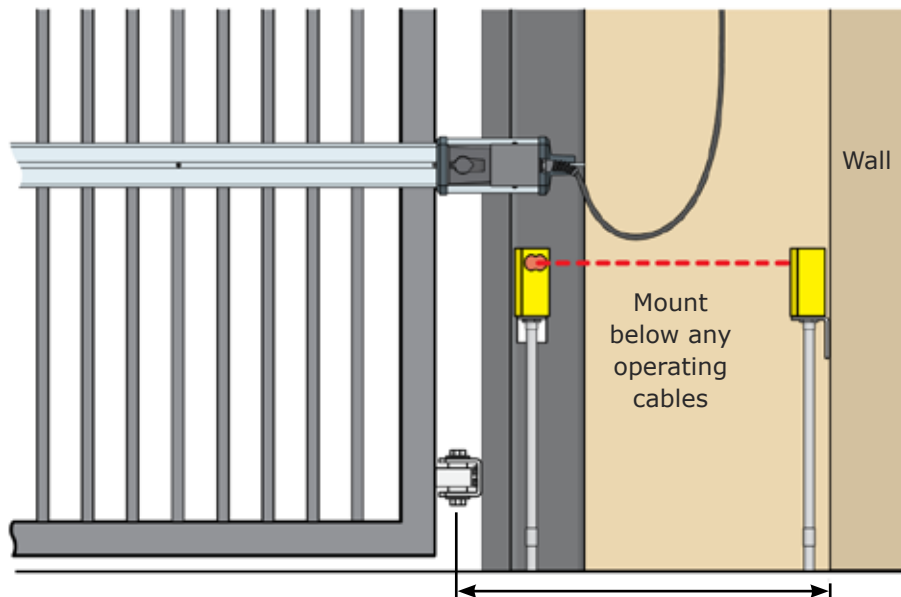

If this space is less than 16", entrapment protection is required in this area.

**Closing Gate  
Top View**

If the closing gate could cause an entrapment, then installation of a monitored entrapment protection device is required.

**Opening Gate  
Top View**

If the opening gate could cause an entrapment, then installation of a monitored entrapment protection device is required.

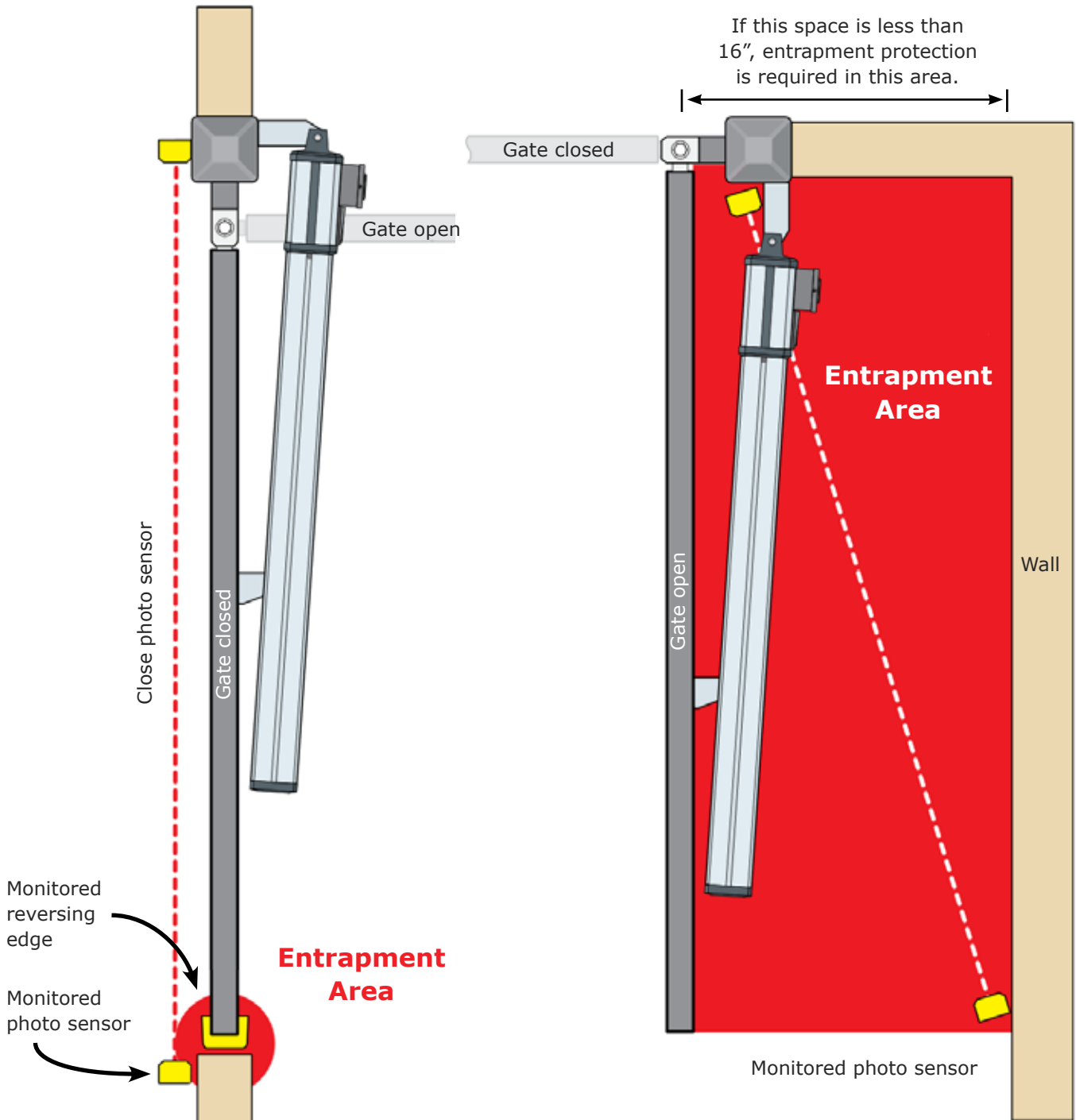

### Swing Gate External Entrapment Protection Devices (continued)

Close Photo Sensor  
Side End View

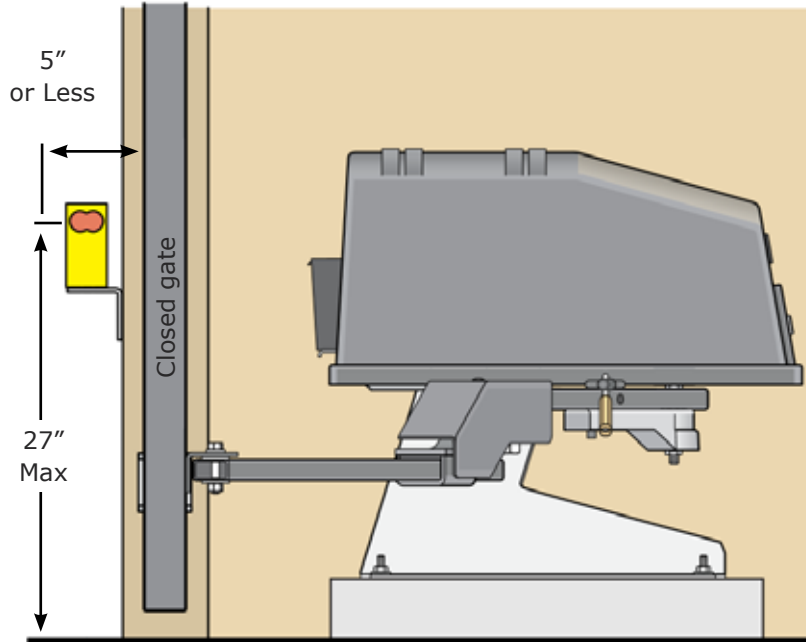

OPEN Photo Sensor  
Secure Side View

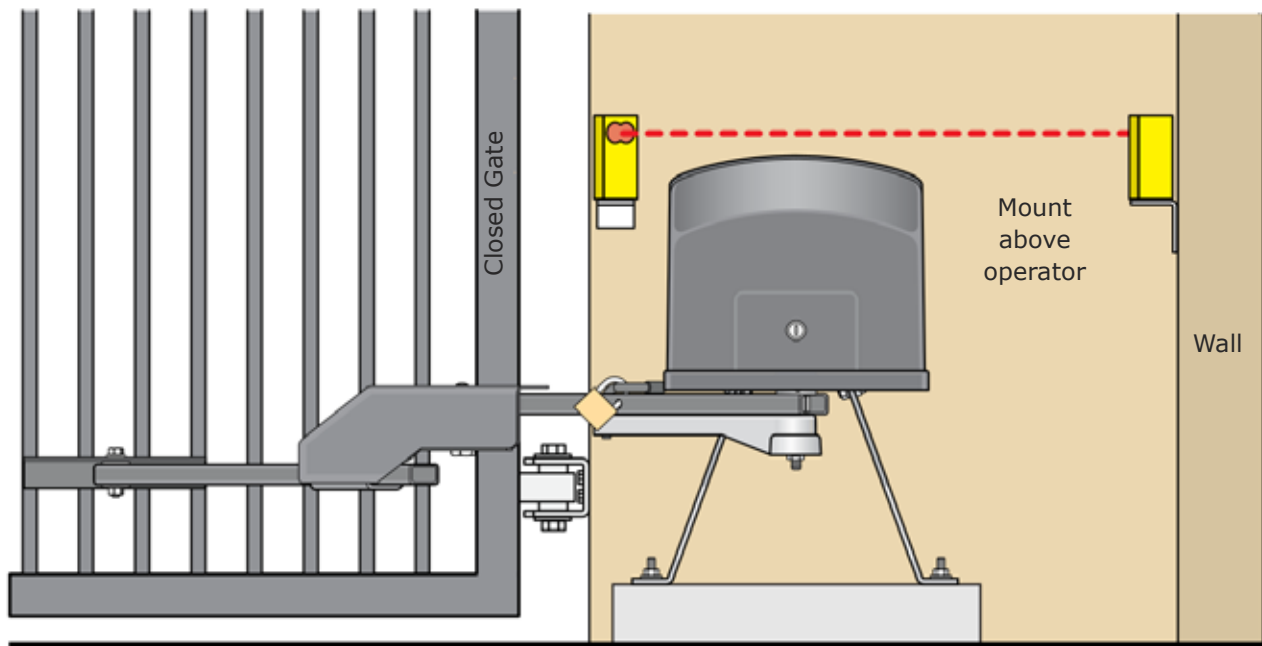

OPEN Photo Sensor  
Top View

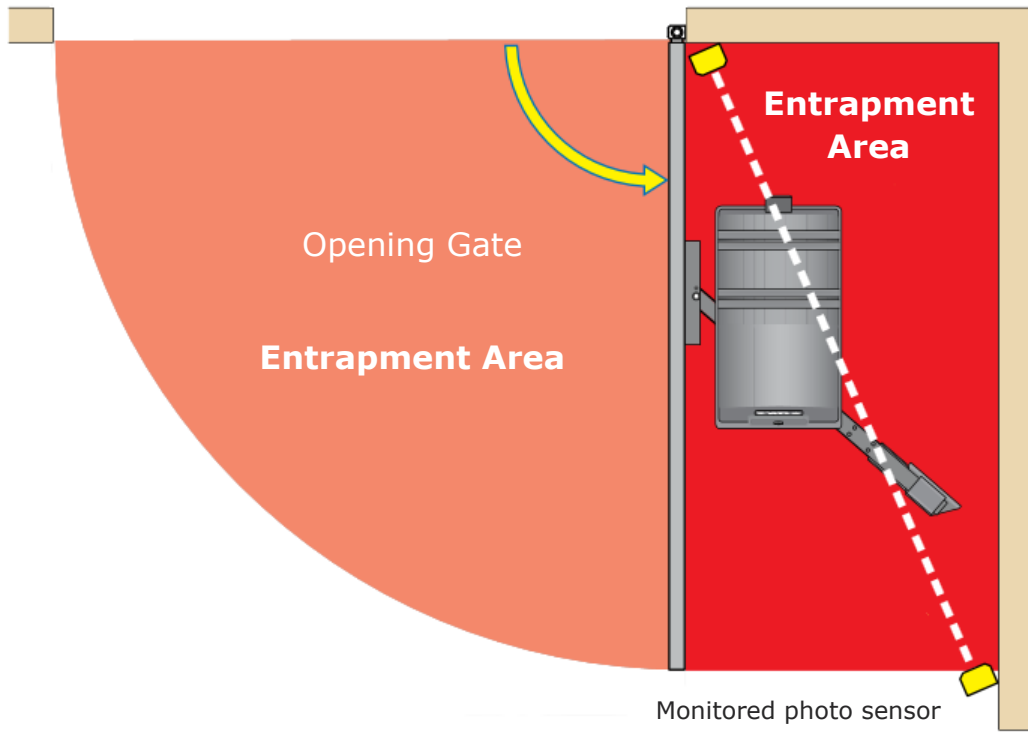

CLOSE Photo Sensor  
Top View

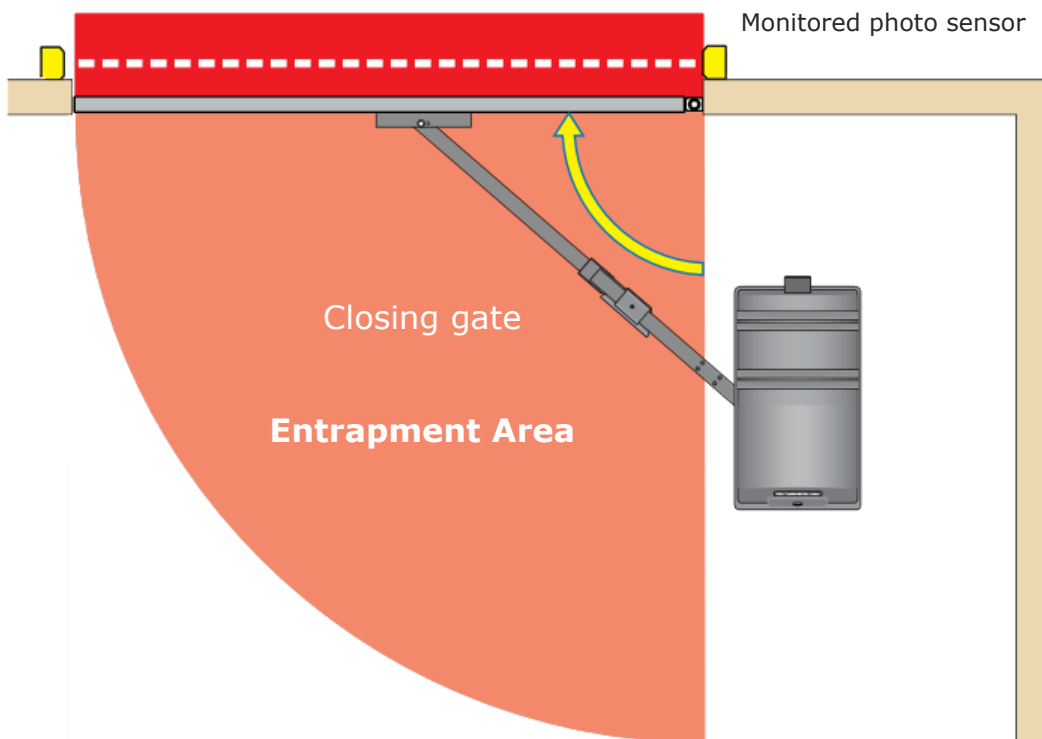

## Swing Gate External Entrapment Protection Devices (continued)

Typical Monitored Reversing Edge Mounted on End of Gate

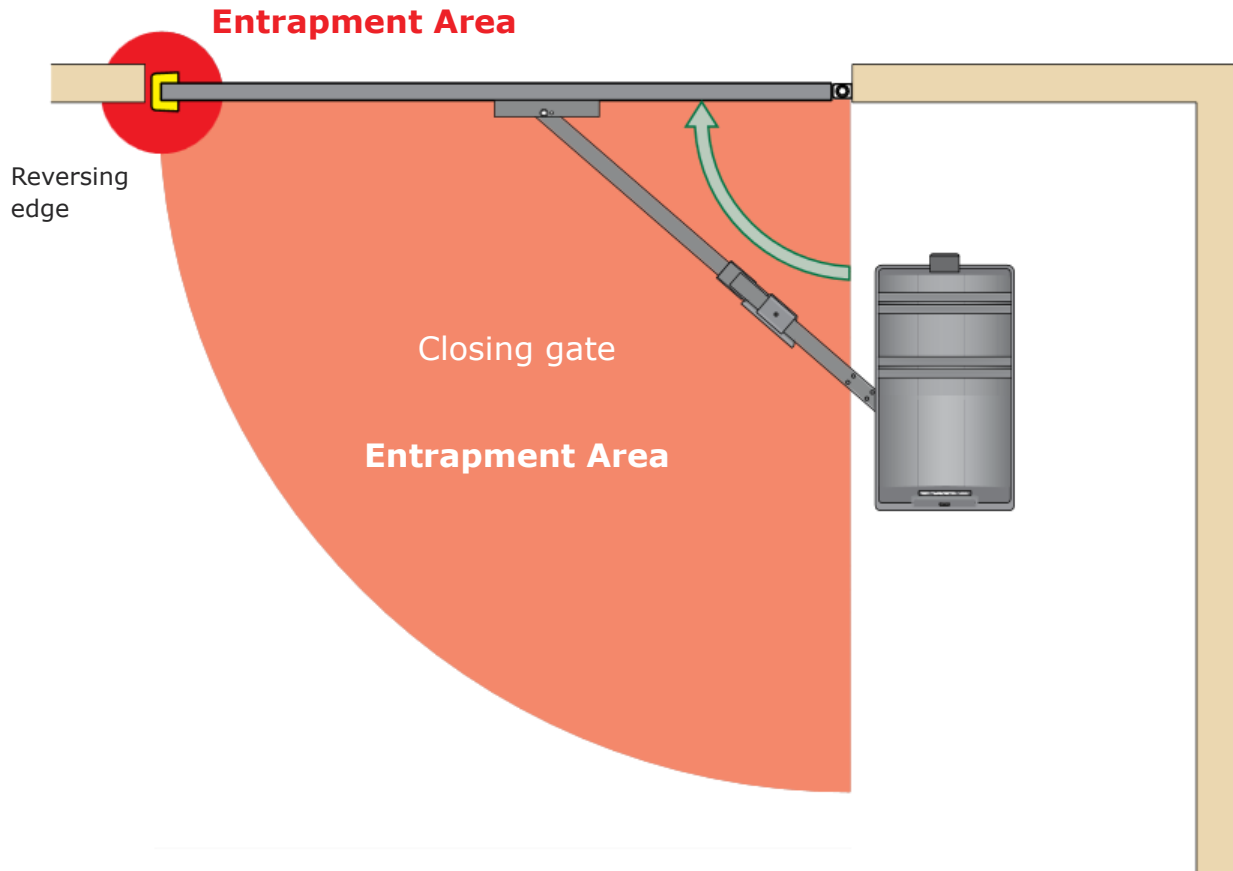

Typical Reversing Edge Mounted on Bottom of Gate

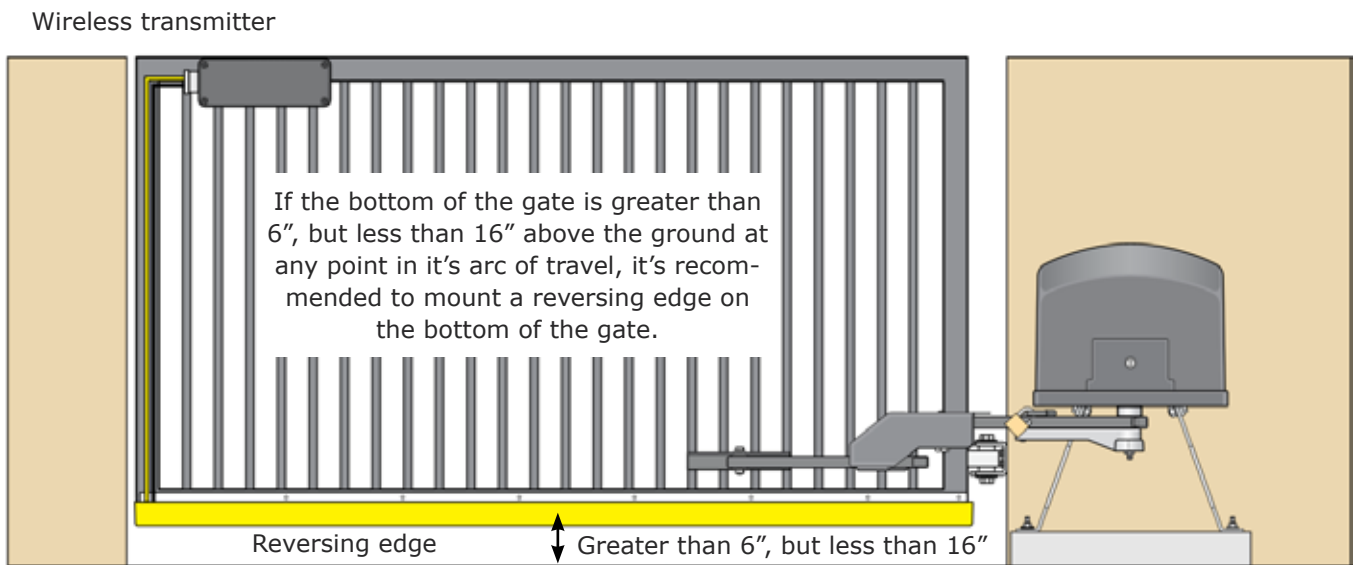





## Safety Information for Barrier Gate Operators

Vehicular barrier gate operators can produce high levels of force. It is important that you are aware and eliminate possible hazards; Pinch Points, Entrapment Areas, Overhead Power Wires, Absence of Controlled Pedestrian Access, and Traffic Management.

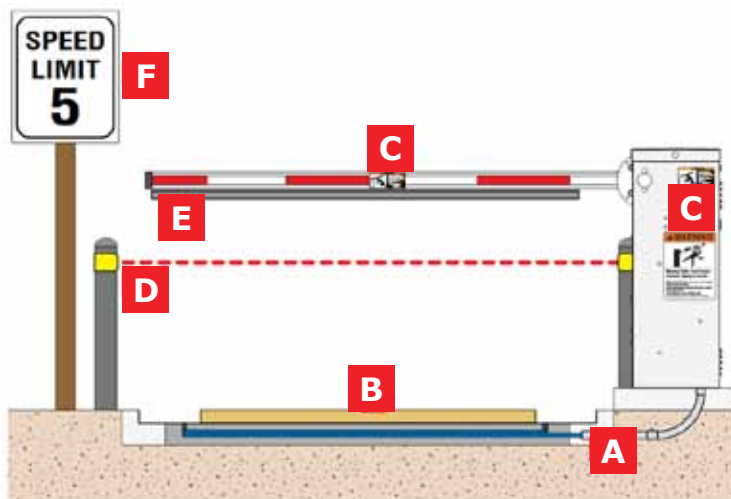
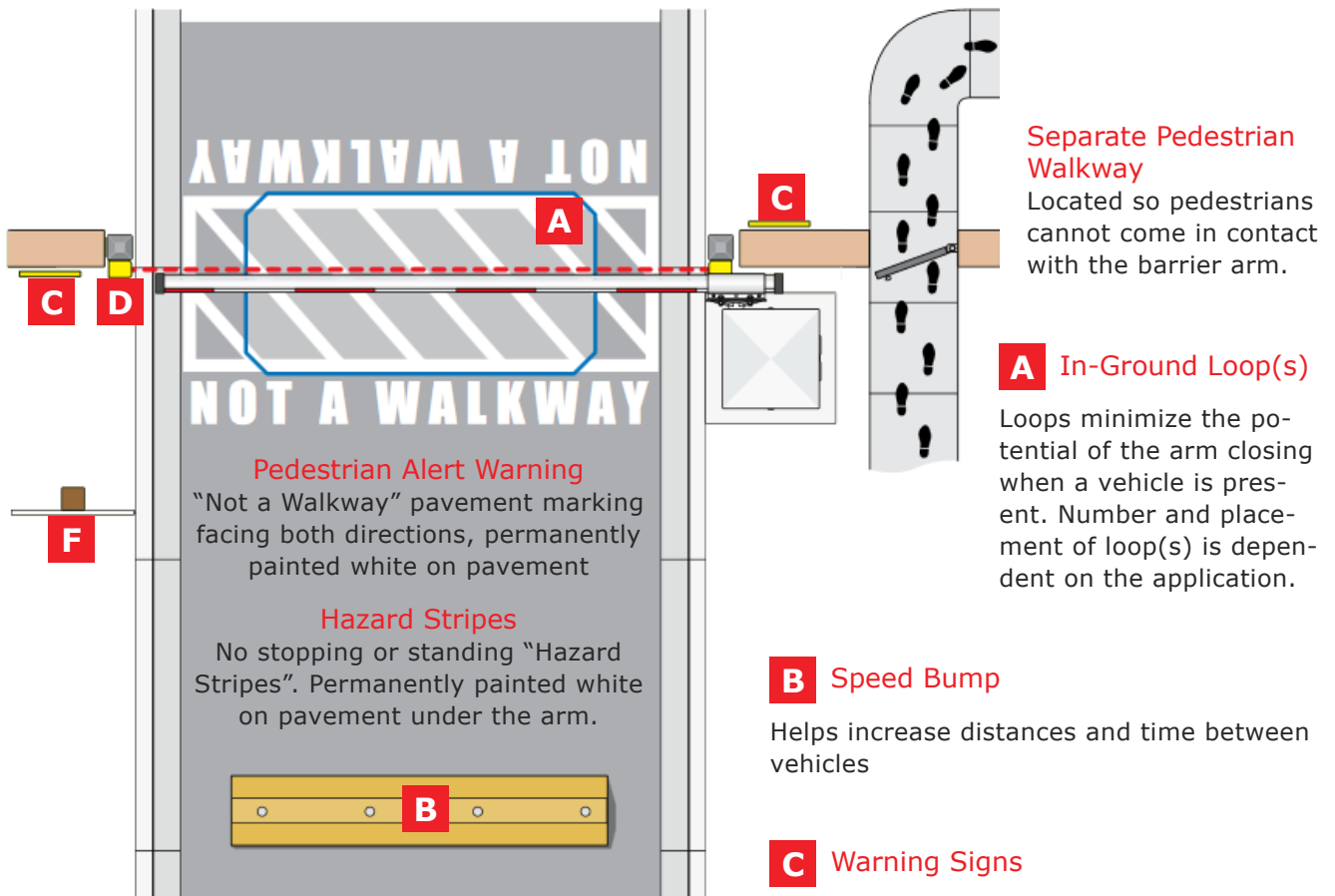



## **Barrier Gate Requirements**

- Make sure all warning signs are on operator and arm.
- Do not install the operator in such a way that the arm moves within 16" of a rigid object or 10' from high voltage power wires with arm in the raised position.
- Speed limit through barrier area is 5 mph. Install speed bumps, warning signs and hazard stripes where visible in the area of the barrier gate. Failure to do so may result in injury, damage to operator and vehicle.
- Users should be familiar with proper use of operator. These include; hardware operation, reversing functions and testing, reversing loops, inherent reversing system, electric edges, photoelectric cells, related external devices and possible hazards.
- Keep adults, children and objects away from operator and hazard zones.
- Automotive traffic only - No bicycles or motorcycles. Pedestrians must be provided with separate access.
- All electrical connections should be made in accordance with local electrical codes.
- Security features should be installed to avoid unauthorized use.
- Controls intended for user activation must be located at least 6' away from any moving part of the barrier gate and where the user is prevented from reaching over, under or around the barrier gate to operate the controls.

**Note:** Emergency access controls only accessible by authorized (e.g. fire, police, EMS) may be placed at any location in the line-of-sight of the barrier gate.

- When manually operating the gate operator arm, the user must make sure that the gate area is clear before operating the control. Any activity in the entrance and exit lanes should be monitored to ensure a safe operation when opening or closing the barrier gate. The motion of the barrier boom must be directly observable by the person operating the barrier. While the barrier boom is in motion, no pedestrian and no vehicle shall be in the immediate vicinity of the barrier.
- When removing the operator lift the arm to the full open position and shut off power at the service panel.
- Operators and components should be properly installed and maintained following the recommended service schedule, test the operator monthly. Keep all debris away from operator housing vents and off of arm.



## **Why Should Installers Follow the UL Standard?**

### **Safety Must be Your Most Important Priority**

It is well known that “a moving gate can cause serious injury and death.” Unfortunately, every year gates do inflict serious injury and sometimes death. Ensuring that your installations are configured to protect all areas of potential entrapment is your first responsibility.

### **Non-Compliance Creates a Serious Business Liability**

Not meeting the UL 325 and ASTM F2200 safety standards has the potential to seriously damage, if not destroy your company in the event one of your installations suffers an accidental injury or death and you end up in court defending your installation practices.

### **Protect Against Personal Injury Lawsuits**

UL 325 and ASTM F2200 are not laws, but in a court of law, your lack of knowledge or compliance to this and other minimum industry safety standards is the kiss of death. That’s not an opinion, it’s the experience of many unfortunate business owners cross examined by a plaintiff’s attorney. The U.S. judicial system doesn’t suffer ignorance, short-cuts, or misapplying safety standards. Not following widely published industry-produced safety standards is indefensible in a court of law.

### **It’s Not a Law, but Code Enforcement is Increasing**

These defenses won’t help you:

- “UL 325 and ASTM F2200 are not laws”
- “I’ll never be caught”
- “No one inspects gates where I do business”
- “The standard isn’t clear – I can’t be held responsible for lack of clarity”
- “It’s the end user’s responsibility, not mine. They forced me to reduce costs so much that I couldn’t afford to protect all potential entrapment areas”
- “If I try to do all that extra stuff, I’ll lose bids, lose jobs . . . I could go out of business while my competitor grows his.”

Plaintiff’s lawyers love these poor defenses. In fact, UL 325 and ASTM F2200 are just starting points. It’s up to installers to audit their site for all safety concerns beyond those presented by UL 325 and ASTM F2200 and to properly address all of those concerns.

Along with the dealers and installers, it is the owner’s and user’s responsibility to be aware of potential hazards associated with an automatic gate system and take appropriate steps to reduce the risk of injury. Be sure all parties read the Important Safety Information found in your gate operator’s manual as it provides more details and safety considerations that can be supplied here.



## **How this Will Affect Dealers and Installers**

- The gate operator manufacturer will indicate the class of each operator in multiple locations.
- Sales personnel must match the site application with the correct Usage Classification of operator.
- Primary and secondary entrapment protection devices must be installed and matched to the operator.
- Waivers of safety or not installing entrapment protection devices is not an option.
- Responsibility for UL safety standards does pass to the dealer and installer.
- Warning signs must be permanently attached within clear view of the moving gate. The installing dealer should take a dated photo of the gate system with the signs in place to prove that they were furnished.
- The dealer and/or installer should develop an installation checklist and customer sign-off form.
- Service and preventive maintenance contracts will be in demand by the customers, and are good for the dealers when they ensure safe and proper operation of the system.
- The issue of safety could give a dealer a good excuse to call on the owners of older systems and inform them that their systems should be safety upgraded to meet the new standards.

### **Maintenance Tips**

- Check that the gate is level. Manually open and close the gate to make sure it travels smoothly
- Check the gate hardware on a regular basis. Tighten any loose fasteners and replace any worn or damaged parts. A smooth running gate prolongs the life of your gate operator
- Before the qualified installer leaves the site, make sure instructions are given to the end user on all operational functions of the gate operator. Teach them how to reset the gate operator, turn off/on power, and manually operate the gate

### **Clutch Adjustment**

Some operators come equipped with a mechanical slip clutch (UL 325 Type C) to further reduce the possibility of injury should an entrapment occur. Do not over tighten the clutch to compensate for a gate that is damaged, poorly constructed or too heavy. Over tightening the clutch would create a hazard which could result in serious injury or death to persons who may become entrapped.

### **Test the Operator Reversing Sensitivity**

Place an immobile object along the gate path, allowing the gate to strike it while in the open and close cycles. The gate must reverse direction after striking the object. If it does not, increase the reverse sensitivity and repeat this test until the correct sensitivity has been set. The operator will assume a soft shutdown after striking and reversing the gate which will require a key switch command to cycle the operator again.

### **Edge Sensor Inventory Warning**

Edge sensors that have been used previously cannot be monitored to comply with the needs of post-2016, UL 325 gate operators. Some operators will require a Normally Closed (NC) adapter device which allows the gate operator to monitor edge sensor presence. While, other gate operators will require new edge sensors featuring a 10k Ohm resistor in order to monitor it's presence.



## Be Aware of Different Manufacturers' Interpretations of UL 325 Compliance

Because the scope of a standard such as UL 325 does not tell manufacturers' exactly how they must implement changes to meet its requirements, and because two people frequently have different interpretations of the same sentence, differences in engineering solutions between manufacturers' products are inevitable. Unfortunately, these differences, especially in the methods of monitoring external entrapment protection sensors, increase complexity in our industry and will likely lead to installer confusion. Distributors, dealers, specifiers, and installers need to become very informed of the new requirements and how each manufacturer has implemented the changes into their products, so that they can educate their staff and end users.

## Where Else Can I Go to Educate Myself About Changes to 2016 UL 325 Standards?

- Gate operator installation manuals & gate operator quick start guides distributed with every operator.
- Manufacture's online or in-person training.
- Distributors online and in-person training. Check with your distributor.

### DASMA - Door & Access Systems Manufactures Association

North America's trade association for manufacturers of garage doors, rolling doors, high performance doors, garage door operators, vehicular gate operators, and access control products.

Door & Access Systems Manufactures Association, 1300 Sumner Ave, Cleveland, OH 44115  
(216) 241-7333  
dasma@dasma.com  
www.dasma.com

### IDEA - Institute of Door Dealer Education and Accreditation

The IDEA is a non-profit educational organization established to meet the informational needs of consumers and the business and accreditation needs of door, gate and operator dealers. As the authoritative voice of the industry, IDEA promotes a better industry and better products that provide enhanced protection against high winds, fire, entrapment, and injuries.

IDEA, PO Box 236, West Milton, OH 45383  
(937) 698-1027  
Fax: (877) 702-8097  
www.dooreducation.com



### **UL - Underwriters Laboratories**

Provides safety-related certification, validation, testing, inspection, auditing, advising and training services to a wide range of clients, including manufacturers, retailers, policy makers, regulators, service companies, and consumers.

UL, LLC, 333 Pfingsten Rd, Northbrook, IL 60062-2096  
847-664-1787  
Fax: 847-407-1787  
www.ul.com

### **ASTM - American Society of the International Association for Testing and Materials**

One of the largest voluntary standards developing organizations in the world. ASTM is a not-for-profit organization that provides a forum for the development and publication of voluntary consensus standards for materials, products, systems, and services.

ASTM Headquarters, 100 Barr Harbor Dr, PO Box C700, West Conshohocken, PA, 19428-2959  
(610) 832-9585  
service@astm.org  
www.astm.org

### **TSW - Total Security Warehouse**

A wholesale distributor of the most widely recognized brands of access control products available on the market. We supply access control solutions to authorized dealers and specifiers from coast to coast. We provide a complete line of access control, gate operators, security products and reversing devices from DoorKing, HySecurity, FAAC, Linear, OSCO, LiftMaster, Chamberlain, and many other leading manufacturers.

TSW, 5100 W Brown Deer Rd, Brown Deer, WI 53223  
(877) 816-7304  
Fax: (262) 814-7302  
info@totalsecuritywarehouse.com  
www.totalsecuritywarehouse.com

**We're social.**    



# Automatic Gate Safety Checklist

## UL 325 and ASTM F2200 Standards for Automatic Slide and Swing Gates

Todays Date \_\_\_\_\_ Site Name \_\_\_\_\_

Site Contact \_\_\_\_\_ Address \_\_\_\_\_

City \_\_\_\_\_ State \_\_\_\_\_ Zip \_\_\_\_\_

Email \_\_\_\_\_ Phone \_\_\_\_\_

### UL 325 Standards

Item	Pass/Fail	Comments
Gate operator is at the current UL 325 Standard	Pass / Fail	
Warning signs are attached on both sides of gate area	Pass / Fail	
<b>Each entrapment zone is covered by two safety devices</b>		
1. Closing Entrapment Area	Pass / Fail	
2. Opening Entrapment Area	Pass / Fail	
3. Other Entrapment Area	Pass / Fail	

### ASTM F2200 Standards - Gate Construction Evaluation

Item	Pass/Fail	Comments
<b>All Gates Types</b>		
Gates have smooth bottom edges, no protrusions	Pass / Fail	
All access controls at least 6' from gate	Pass / Fail	
Barbed tape at least 8' above grade	Pass / Fail	
Barbed wire at least 6' above grade	Pass / Fail	
Separate pedestrian gate that is out of reach of the moving gate	Pass / Fail	
<b>Swing Gates Only</b>		
Gate's pivot point is less than 4' from column edge	Pass / Fail	
Distance from the open gate to a wall, column, or entrapment area is greater than 16"	Pass / Fail	
<b>Slide Gates Only</b>		
Roller covers on cantilever wheels	Pass / Fail	
If pickets are spaced equal to, or greater than 2 1/4" apart, meshing is installed up to 6' above grade	Pass / Fail	
Gate does not move on it's own when power is turned off	Pass / Fail	
Gap between gate and stationary fence posts less than 2 1/4"	Pass / Fail	
Positive stops at both the fully open, and closed positions	Pass / Fail	
Receiver guides recessed behind the receiver post if below 8'	Pass / Fail	
Catch post installed to prevent gate from falling if disconnected from supporting hardware	Pass / Fail	
Other	Pass / Fail	





# Automatic Gate Safety Checklist

## UL 325 and ASTM F2200 Standards for Automatic Slide and Swing Gates

### Slide Gate Requirements

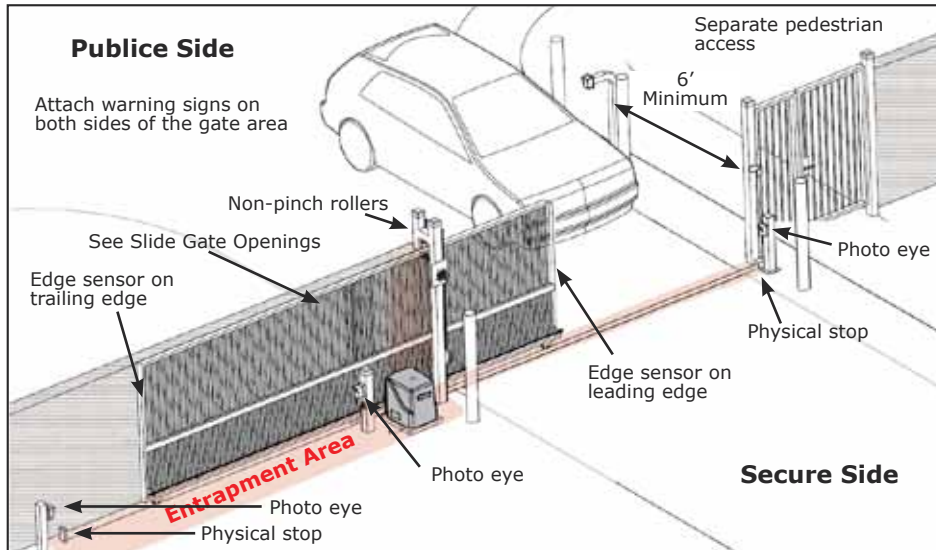

### Slide Gate Spacing

A gap, measured in the horizontal plane parallel to the roadway, between a fixed stationary object nearest the roadway and the gate frame when the gate is in either the fully open or fully closed position, shall not exceed 2 1/4".

**Exception:** All other fixed stationary objects greater than 16" from the gate frame shall not be required to comply with this section. (ASTM F2200: 4.8)

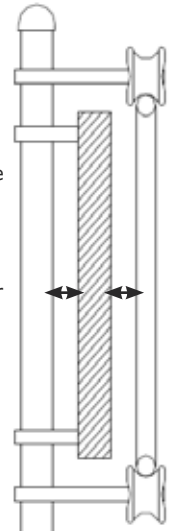

### Slide Gate Requirements

Openings of a horizontal slide gate must be smaller than 2 1/4" or else be guarded or screened. These design rules apply to both the moving gate as well as the portion of adjacent fence that the gate covers in the open position. (UL 325: 56.8.4.a.2 and ASTM F2200: 6.1.2)

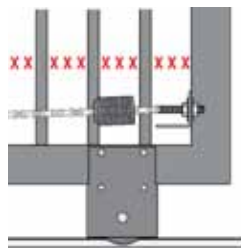

If gaps between vertical bars of the gate or fence are less than 2 1/4", no further screening is required.

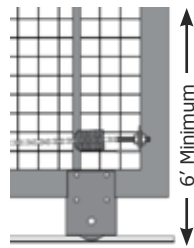

For gaps equal to or larger than 2 1/4", a wire mesh screen must be applied to the gate. Wire mesh screen openings must be smaller than 2 1/4". The minimum height of wire mesh screen is 6' above grade.

### Base of Slide & Swing Gate

All gates must have smooth bottom edges, no protrusions. If gate hardware or sensors protrude, they must have smooth surfaces that do not exceed beyond 1/2" beyond the base of the gate. (ASTM F2200: 4.8)

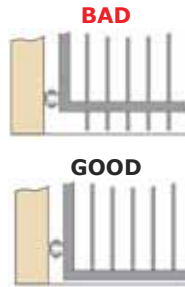

### Swing Gate Requirements

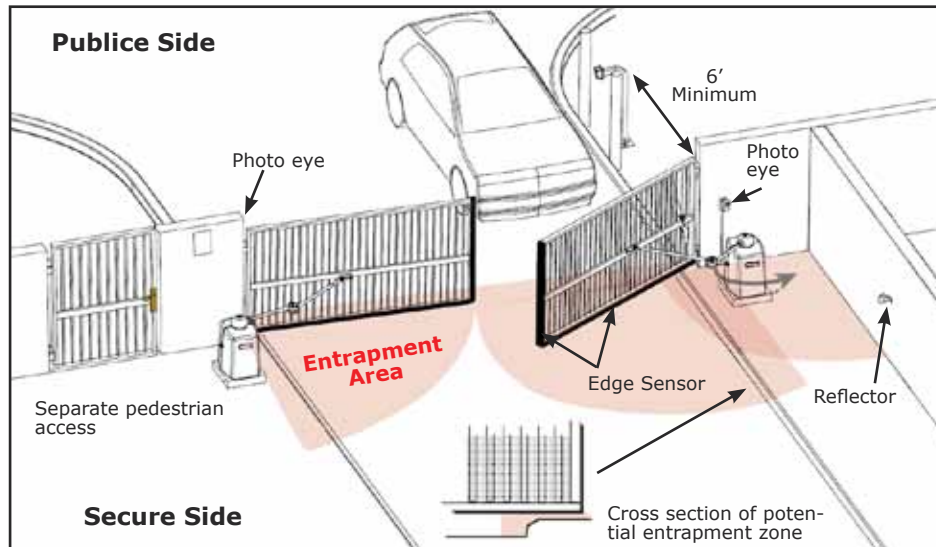

### Swing Gate Clearance

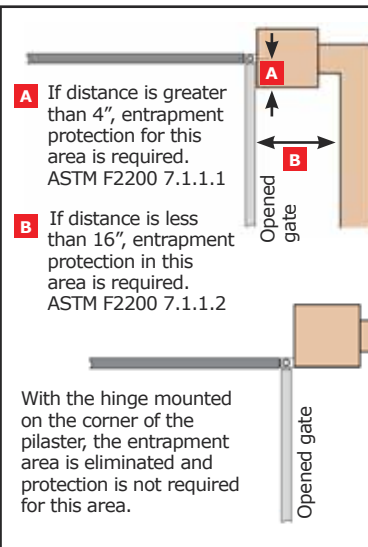

Service Company \_\_\_\_\_

Inspector's Name \_\_\_\_\_

Inspector's Signature \_\_\_\_\_

Customer Signature \_\_\_\_\_



## Frequently Asked Questions About UL 325-2016

**Q: Will there be any entrapment protection devices included with the gate operators?**

**A:** Each manufacture is different, but generally no. Gate operators will not be bundled with any entrapment protection devices. Each gate system installation is unique and the decision is best left to the installing professional

**Q: Will there be new part numbers for the 2016 operators?**

**A:** Each manufacture is different. It is recommended to check with your sales representative.

**Q: Is compliance with UL 325 a national law?**

**A:** No. However, it became a state law in Nevada effective March 1, 2000. DASMA is continuing to monitor other states for potential legislation in this area.

**Q: Who is going to check the gate system to determine if it is in compliance with the new standard?**

**A:** No one at the present time. However, keep in mind two things: a) the Consumer Product Safety Commission has submitted a proposed revision to the new International Building Code where, if passed, building code officials would be inspecting gate systems for compliance where the IBC is adopted and enforced, and b) there is the potential for liability if a gate system is not installed in compliance with UL 325.

**Q: Am I required to upgrade existing installed operators to the new UL 325 standard?**

**A:** No. There is no retroactivity with respect to UL 325.

**Q: Can older operators that do not meet the standard be repaired?**

**A:** Yes. You may wish to contact your attorney or your trade association legal counsel regarding liability issues in repairing older operators that have no entrapment sensing provisions.

**Q: Can I upgrade, to the new standard, operators already installed?**

**A:** There are no requirements to upgrade existing operators. However, upgrading is dependent on the product itself; the operator manufacturer must be consulted on this matter.

**Q: What happens with the product that I have in stock that was purchased prior to March 1, 2000? Can I still install it?**

**A:** Yes. There is no recall provision in the UL standard. Products that have already been tested and listed can be installed.

**Q: What is the significance of the operator usage classifications?**

**A:** The classifications are intended to signify specific end use applications as defined in UL 325.

**Q: Can operators be classified under more than one of the classifications?**

**A:** Yes. UL 325 requires that "A vehicular gate operator shall be permanently marked to specify all intended Classes of applications."



**Q: What is the difference between a primary and secondary entrapment protection device?**

**A:** The secondary entrapment protection device is intended as a backup feature should the primary device fail or not work properly.

**Q: Do photoelectric cells or electric edges have to be installed on all gates?**

**A:** Not necessarily; these two options are among several acceptable options. Contact the operator manufacturer for acceptable protection devices to be installed on a particular gate.

**Q: Do I have to install both photoelectric cells and reversing edges as secondary devices to be in compliance with the standard?**

**A:** No; you do not have to put both on the gate. Either a non-contact sensor, a contact sensor, or a combination thereof can be used as secondary devices.

**Q: Will an operator function if a photoelectric cell or reversing edge is not connected?**

**A:** This is dependent on the operator design. The operator manufacturer must be consulted on this matter.

**Q: How far away from the gate should an access device (push button, card reader, etc.) be installed?**

**A:** The first sentence of Section 51.8.4 f) reads, "Controls must be far enough from the gate so that the user is prevented from coming in contact with the gate while operating the controls."

**Q: If a reset switch is to be installed, where does it have to be installed?**

**A:** UL 325 requires that "Controls intended to be used to reset an operator after two sequential activations of the entrapment protection device or devices must be located in the line-of-sight of the gate."

**Q: Do I have to install a separate pedestrian gate?**

**A:** UL 325 states that if the operator is for a vehicular gate, pedestrians must use a separate entrance.

**Q: Do I have to install guarding or screening on a gate?**

**A:** Yes. However, this applies only to horizontal sliding gates. The important fact to remember is that if a horizontal gate system is not guarded or screened in accordance with the manufacturer's instructions, it cannot be claimed to be in compliance with UL 325.

**Q: Does the 2 1/4" sphere test start at the bottom of the gate or is it measured from the ground up to 4'?**

**A:** UL 325 requires that "All openings of a horizontal slide gate are guarded or screened from the bottom of the gate . . ."

**Q: If a slide gate is on wheels and there is a 4 inch gap between the ground and the bottom of the gate, is this OK?**

**A:** The standard does not include provisions governing the gap between the bottom of the gate and the ground. However, the American Fence Association (AFA), DASMA and the National Ornamental & Miscellaneous Metals Association (NOMMA) are working on a joint gate construction and installation standard that will address this matter.



## Frequently asked questions about UL 325-2016 *(continued)*

**Q: Do swing gates need to be guarded or screened so that a 2 1/4" sphere will not pass through it?**

**A:** No, only slide gates are required.

**Q: Is there a difference between a UL listed product, an ETL listed product, or a product listed by anyone else?**

**A:** Any listing by a nationally recognized testing laboratory (NRTL) that tests to the UL 325 standard is acceptable. The test laboratories are expected to use the same standard.

**Q: Do I need to test my gate operator with each different external entrapment protection device (B1 and B2 devices)**

**A:** Short answer is yes. Section 31 defines the types of devices, and the functional requirements that must be met for each type of device. Section 34 specifies required tests and functional requirements for external devices. Section 25 specifies required tests and functional requirements for circuits performing safety functions including entrapment protection. While some testing can be done separately on the operator and on the external device, some of the testing requires the interoperability and connection for the external device(s) to the operator to determine proper "system" function during and after testing. Thus, each external device must be tested with each operator.

**Q: What is considered a monitored device?**

**A:** Per UL 325, Par. 31.1.7 - A gate operator installed in accordance with the manufacturer's instructions utilizing external entrapment protection designated Types B1 or B2 in Table 31.1 to comply with 31.1.1 by having provision for connection of such device, or providing such device with the operator, shall monitor for the presence and correct operation of the device at least once during each open and close cycle. Should the device not be present, or a fault condition occur that precludes the sensing of an obstruction, including an interruption for the wireless signal to the wireless device or an open or short circuit in the wiring that connects the external entrapment device to the operator and the device's supply source, the operator shall function as required by 31.1.17.

**Q: What is a "cycle" for a gate operator?**

**A:** Per UL 325, Par. 31.1.7" Each open and close cycle = Open/Pause/Close

**Q: What UL 325 changes become mandatory on January 12, 2016?**

**A:** Not much and a lot. The primary change now mandates that all external sensors intended to protect against entrapment must be monitored for presence and correct operation at least once per gate cycle. Since 2000, UL 325 required that gate operators have two independent means of entrapment protection, both of which serve to protect the open and close directions of gate travel. However, there is a broad exception to monitored entrapment protection for barrier arm gates where the arm does not move within close proximity to a rigid object. For most gate operators, one of the two required means of entrapment protection is the Inher-

ent Sensor (Type A) within the gate operator and the second means of entrapment protection are typically the external sensors that are installed during gate installation. Any external entrapment protection sensor that protects against entrapment in the open and/or close directions of gate travel must be monitored by the gate operator for presence and correct operation. A constant hold input is necessary, in the same direction of travel, for any entrapment sensor that is not installed or has failed. The constant hold input, such as from a three-button station, ensures that the person pushing the button is monitoring the entrapment zones.

**Q: How many external entrapment protection sensors (as a combination of photo eyes and edge sensors) are required in a typical automated gate installation?**

**A:** That depends on the number of entrapment zones that must be protected. Most of the time, a minimum of two external entrapment protection sensors will be required. One sensor to protect against entrapment in the open direction of gate travel and one sensor for the closed direction of gate travel. If you use edge sensors on a swing gate, Wraparound edge sensors, which serve to protect in both directions of travel, allow you to install only one external sensor, unless other entrapment zones exist. Some sliding gate configurations may allow installation of one long-range photo eye to protect the entire travel area of a slide gate. UL 325 sets a minimum standard that both directions of gate travel must be protected with external sensors, however the installer must assess each specific site and install sensors that protect all potential entrapment zones.

*Example 1* - If gate operator used Type A (inherent) and Type D (hold-to-run) control, the zero external devices may be required.

*Example 2* - If gate operator uses Type B1 and Type B2 devices as the only means, then minimum of two are required for each direction of travel. However, depending on the specific gate installation, there may be more than one "zone" where risk of entrapment exists. In this case, additional devices may be needed such that there are two means of protection in each direction for travel for each potential entrapment zones. Consult UL 325, Section 58.8 (instructions) and F2200.

**Q: What choices did manufacturers have in order to comply with the UL 325 mandate for monitored sensors? Did it require significant changes to their operators?**

**A:** Manufacturers had a choice of three different routes to monitor external sensors for presence and proper operation.

- Connecting sensors to gate operators with a NC (Normally Closed) circuit
- Detecting a frequency or pulse generated by the sensor (2 or 4 wire)
- Detecting a resistor, typically 10k $\Omega$  which allows a small current to bleed through the circuit

**Q: How many monitored external sensors can I connect to a HySecurity gate operator?**

**A:** All HySecurity control boards have three function programmable external entrapment sensor inputs. The inputs are marked Sensor 1, Sensor 2 and Sensor 3. Only one sensor can be connected to each input, so a maximum of three external sensors can be used. If you need to have more external sensors, an adapter made by Miller Edge named The Solution (part number MIM-62) can be added. The Solution module has six inputs and two outputs, which will be wired to HySecurity's Sensor 1 and Sensor 2 inputs. Together with the still available Sensor 3 input, the maximum number of external sensors that can be connected is seven.



## Frequently asked questions about UL 325-2016 *(continued)*

**Q: Can I use the new blue-taped Miller edges with a 10k Ohm resistor on 2015 and older gate operators without a monitoring circuit?**

**A:** No. For 2015 and older gate operators, you must be certain to add the GEM-104 module as an interface or buy edge sensors without the 10k Ohm resistor. Directly connecting an edge sensor, with a 10k Ohm resistor, to a controller is likely to falsely trigger the Edge sensor input.

**Q: Can the warn-before-operate audio alert be used as one of the UL 325 Entrapment Protection devices?**

**A:** No. A warn-before-operate audio alert is no longer designated by UL 325 as an acceptable Entrapment Protection device. However, most operators are built with a programmable warn-before-operate audio alert and it is strongly recommend to use it as an additional warning against potential entrapment.

**Q: What happens if one of the external Entrapment Protection sensors becomes disconnected or fails in a HySecurity Gate Operator?**

**A:** The operator will stop cycling in automatic mode. The gate operator monitors the "Presence" and "Correct Operation" of each entrapment protection sensor. When the operator no longer detects a properly functioning sensor, it will cease automatic operation only in the direction of the missing or failed sensor. The operator will still function, but only with a "Constant Hold Input" from an access control device.

**Q: I normally installed edges sensors on the leading and trailing end of a sliding gate. Isn't that the best way to protect against entrapment?**

**A:** Not necessarily. While the leading and trailing ends of a sliding gate are within potential entrapment zones, the risk of entrapment, death or serious injury is high at the "Draw-In" zones. Common installer practice has been to prioritize installation of edge sensors on both ends of a sliding gate, while not protecting the "Draw-In" zones where the gate travels past a rigid object such as a wall, gate support posts or stationary fences.

**Q: What photo eyes and edge sensors are approved for use with each gate operator?**

**A:** This list will change as new products come to market and are tested for use with each gate operator. See updated lists on the manufacture's website, on labels affixed to the gate operator boxes and gate operator installation manuals

**Q: Can any UL Recognized or ETL Listed sensor be installed with any UL or ETL Listed gate operator?**

**A:** No. In addition to UL component Recognition or an ETL Listing, a sensor must be tested together with the gate operator in order to meet 2016 UL 325 Standard of Safety. According to Underwriter Laboratories:

You must consult your gate operator manual to determine the components that are tested and approved for use with that specific gate operator. All entrapment protection sensors, such as photo eyes and edge sensors, must be tested by UL, ETL or another Independent Test Laboratory. Successfully passing a UL component test allows the component manufacturer to "Mark" the product with a label that looks like one of these:

However, neither "UL Recognized" nor "ETL Listed" as above fully qualifies a component to be used with a gate operator. Each sensor, brand and model, must still pass another test proving compatibility and functionality when connected to a UL 325 Listed or ETL Listed gate operator. All gate operator manufacturer's installation instructions must list the sensors which are approved for connection to their gate operators.





**Q: Will there be a time when all UL 325 Recognized or ETL Listed sensors will qualify them for use with any UL or ETL listed gate operator?**

**A:** Possibly, but not today. Underwriter Laboratories and Industry organizations are currently considering a CEI, Common External Interface proposal. Adoption of this proposed standard addition could preclude the need for the additional gate operator specific test of those devices. Component and gate operator manufacturers will announce if and when such a change to the UL 325 standard is adopted.

**Q: Do gate operators manufactured prior to January 12, 2016 require Monitored Entrapment Protection Sensors?**

**A:** No. Monitoring of external entrapment protection sensors is only required when the gate operator is manufactured after January 11, 2016. However, it has always been the installers' and end users' responsibility to ensure that sufficient external entrapment protection sensors are installed to protect all entrapment zones, even if that demands more than the minimum UL 325 requirement.

**Q: Will I have to update previous installs or gate operators manufactured prior to 2016 to meet the requirements for Monitored Entrapment Protection Sensors?**

**A:** No. Monitoring of external entrapment protection sensors is only required when the gate operator is manufactured on or after January 12, 2016.

**Q: Are there specific type of edge sensors recommended in certain applications?**

**A:** Yes, Miller Edge Wraparound style edge sensors (MGS or MGR) on the leading end of a swing gate with a 2" frame. Wraparound style edge sensors allow one edge sensor to protect in both the open and close directions of swing gate travel. If your swing gate frame cannot fit 2" wraparound edge sensors, you will need to use at least two standard edge sensors.

**Q: What UL 325 inspired changes may impact my external sensor choices?**

**A:** The UL 325 requirement for monitoring external sensors means that a monitored wireless transmitter/receiver will be required for any edge sensor that is not directly wired into the gate operator. Many installers have in the past used a simple edge transmitter with a standard receiver for wireless edge sensors, but the older edge transmitter/receiver cannot be monitored, so new monitored wireless transmitter/receiver hardware will be required. This is because ALL external entrapment protection sensors MUST now be monitored by the gate operator. The expense and complexity of a monitored wireless transmitter/receiver may mean that some installers decide to change their installation practices and choose locations for edge sensors that can be wired directly into the gate operator. Some installers may develop a preference to use photo eyes as entrapment protection sensors, because a photo eye may be easier to install and monitor than an edge sensor and because a photo-eye offers non-contact protection.



## Frequently asked questions about UL 325-2016 *(continued)*

**Q: In the past, I've had issues with photo eyes, especially reflective photo eyes that have falsely held a gate open. Is there something that I can do to assure of reliable photo eye performance?**

**A:** Yes. Not all photo eyes are created equal. Be very careful about trusting the published photo eye maximum range. Manufacturers frequently do not tell the whole story when publishing the maximum range of their photo eyes. This is especially true for reflective style photo eyes. A photo eye must have significant "excess gain" to ensure reliability in outdoor applications, because fog, ice, snow and dirty optical surfaces all occur normally in outdoor environments. Unfortunately, most photo eye manufacturers do not publish their "excess gain" charts. They generally publish only a theoretical maximum range, which may suffice for indoor use. Be conservative when using photo eyes with longer gates. As a quick rule, limit the distance that you use a photo eye in an outdoor application to a maximum, of 75% of manufacturers' published range. Some photo eyes only reliably operate at 50% of their published range. If your gate location is subject to occasional heavy fog, we recommend you limit the distance spanned by a photo eye to 50% of its published range.







## Glossary

**Bottom Retainer** - An angle or lip attached to the bottom horizontal member of a slide gate, usually used on a gate installed in a high security-related application, intended to protect a gate from crash-through related damage from vehicular impact.

**Catcher** - see Receiver

**Commercial/ General Access Vehicular Gate Operator - Class II** - A vehicular gate operator (or system) intended for use in a commercial location or building such as a multi-family housing unit (five or more single family units), hotels, garages, retail store, or other building servicing the general public.

**Gate** - A moving barrier such as a swinging, sliding, raising, lowering, or the like, barrier, that is a stand-alone passage barrier or is that portion of a wall or fence system that controls entrance and/or egress by persons or vehicles and completes the perimeter of a defined area.

**Gate Latch** - a manual mechanism that secures the gate in either the fully closed or fully open position.

**Gate Lock** - an electromechanical mechanism that locks the gate in either the fully closed or fully open position.

**Entrapment** - The condition when an object is caught or held in a position that increases the risk of injury.

**External Entrapment Protection Device** - A device, examples being an edge sensor, a photoelectric sensor, or similar entrapment protection device, which provides protection against entrapment when activated and is not incorporated as a permanent part of an operator.

**Industrial/ Limited Access Vehicular Gate Operator - Class III** - A vehicular gate operator (or system) intended for use in an industrial location or building such as a factory or loading dock area or other locations not intended to service the general public.

**Inherent Entrapment Protection System** - A System, examples being a motor current or speed sensing system, which provides protection against entrapment upon sensing an object and is incorporated as a permanent and integral part of the operator.

**Positive Stop** - a physical device that limits gate travel.

**Protrusion** - an object less than 9 in<sup>2</sup> of cross sectional area and permanently attached to the gate with a surface that extends beyond the extreme horizontal or vertical planes created by the gate structure members.

**Receiver Guide** - a device mounted to a post or other fixed object which provides lateral stability to a closed gate.

**Receiver Post** - a post to which a receiver guide is attached.

**Residential Vehicular Gate Operator - Class I** - A vehicular gate operator (or system) intended for use in a home of one to four single family dwelling, or garage or parking area associated therewith.



**Restricted Access Vehicular Gate Operator - Class IV** - A vehicular gate operator (or system) intended for use in a guarded industrial location or building such as an airport security area or other restricted access locations not servicing the general public, in which unauthorized access is prevented via supervision by security personnel.

**System** - In the context of these requirements, a system refers to a group of interacting devices intended to perform a common function.

**Vehicular Barrier (Arm) Operator (or System)** - An operator (or system) that controls a cantilever type device (or system), consisting of a mechanical arm or barrier that moves in a vertical arc, intended for vehicular traffic flow at entrances or exits to areas such as parking garages, lots or toll areas.

**Vehicular Overhead Pivot Gate** - a gate made in one rigid piece designed to close an entire opening at a vehicular entrance or exit to a drive, parking lot, or the like, where opening and closing is accomplished by pivoting the gate about an axis, with or without a horizontal track to guide the top of the gate.

**Vehicular Horizontal Slide-Gate Operator (or System)** - A vehicular gate operator (or system) that controls a gate which slides in a horizontal direction that is intended for use for vehicular entrance and exit to a drive, parking lot, or the like.

**Vehicular Horizontal Slide Gate** - a gate that slides in a horizontal direction and is intended for use at a vehicular entrance or exit to a drive, parking lot, or the like.

**Vehicular Horizontal Swing Gate** - a gate that swings in a horizontal in a horizontal plane and is intended for use at a vehicular entrance or exit to a drive, parking lot, or the like.

**Vehicular Vertical Lift Gate** - a gate that moves in the vertical direction and is intended for use at a vehicular entrance or exit to a drive, parking lot, or the like.

**Vehicular Swing-Gate Operator (or System)** - A vehicular gate operator (or system) that controls a gate which moves in an arc in a horizontal plane that is intended for use for vehicular entrance and exit to a drive, parking lot, or the like.

**Vehicular Vertical Pivot Gate** - a gate that moves in an arc in a vertical plane and is intended for use at a vehicular entrance or exit to a drive, parking lot, or the like.

**Weight Bearing Exposed Roller** - an exposed roller that supports weight from the gate.

**Wireless Control** - A control implemented in means other than fixed physical interconnections (such as radio waves or infrared beams) between the control, the associated devices, and an operator to perform predetermined functions in response to input signals.