

ULTIMA® #53-644 Programmable Digital Ignition System



• DESCRIPTION

The Ultima® Digital Ignition is designed to provide the correct curves and total timing for **Ultima engines** and other larger cubic inch or high performance engines. These units will also replace the OEM HD® factory ignition module and sensor used on 1983 and later Harley-Davidson EVO motors. It is also an ideal upgrade for early electronic and breaker-point systems that require a mechanical advancer. The entire ignition fits inside the engine in place of the cam sensor or point plate and connects directly to the coils without the use of an external module.

This unit will operate in single - or dual-fire mode and features 8 advance curves and 4 rpm limits to fit a broad range of engine builds and riding styles. For nitrous and turbo equipped bikes, a single stage retard is provided.

A tach output is included, eliminating the need for an additional adapter when operating in single fire mode. Two diagnostic indicators assist in trouble shooting and static timing.

Ultima® **53-644** ignition module is preset to 3 dead-revolutions (no spark) to aid in easier starting & longer starter life.

For kickstart application, programming software will need to be purchased separately. This allows the installer to remove the dead-revs. The ignition will then spark on the first compression/spark event.

• INSTALLATION NOTES

****IMPORTANT**** Coil primary resistance must be in the range of 2.5 to 3.5 ohms.

****IMPORTANT**** Carbon, graphite or spiral core type suppression spark plug wires are required to reduce interference. Do not use metal core wires.

****IMPORTANT**** This Ultima Ignition requires the gold colored timing rotor used on 1983 and later EVO motors (HD part no. 32402-83). The earlier silver colored cup will not work properly. Bikes originally equipped with points (except distributors) or early electronic ignition will accept the later model cup without modification.

• DUAL FIRE INSTALLATION

Single plug: use Dynatek DC6-1 or a coil with 2.5 - 3.5 ohms resistance. Dual plug: use two DC2-1 coils wired in series (equals 3 ohms).

1. Remove the stock ignition module. Remove the outer and inner covers on the cam position sensor. Mark the engine case near the middle of the sensor. Remove the cam position sensor. The pins may be removed from the connector housing by slowly but firmly pulling the wires from the rear of the connector.

2. Feed the wires of the ignition through the hole in the engine case and seat the ignition. Rotate until the timing pickup (nearest to the switches) is at the mark made in step 1. Replace the screws that held the cam position sensor, finger tight.

3. Remove the wires from the coil. Use a test light or meter to find the white wire that has +12V when **both** the key and the Run/Stop switches are on (later models have only a single white/black wire). Attach this **and** the white wire from the ignition to one of the primary terminals. Attach the pink wire from the ignition to the other primary terminal.

4. Tach connection (if equipped). Attach the pink wire from the tach to the ignition green wire with the large (.250) blade connectors. If the bike had only one pink (or pink/black) wire at the coil, connect this to the ignition green wire.

Do not connect the ignition tach wire to the coil or damage to the ignition may result.

5. Remove the wire from the VOES (Vacuum Operated Electronic Switch). Connect the ignition purple wire with the small (.187) receptacle terminal. If the VOES is not installed, see the tuning tips on the last page. On all **Ultima Engines**, we do not recommend the VOES switch.

The blue wire is left unconnected. If there is no tach, the green wire is left unconnected. These should be folded back and tucked into the harness sleeve. The unused stock wire harness can be removed or taped up.

6. Skip to the "Configuring The Mode Switches" section of these instructions.

• SINGLE FIRE INSTALLATION (Two coils, one firing each cylinder)

Single plug: use Dynatek DC6-5 Twin-Fire II Performance Coil or two DC3-1 single output coils. Dual plug: use two DC1-1 coils or DC6-4 Twin-Fire. Mounting brackets for two-coil installations are available from your dealer.

1. Follow the "Dual Fire Installation Instructions" above, through step 2.

2. Remove the coil. Use a test light or meter to find the white wire that has +12V when **both** the key and the Run/Stop switches are on (some models have only a single white/black wire). Attach this **and** the white wire from the ignition to the coil (+) terminal (a jumper is supplied for two-coil installations). Note: dual tower coils do not have a (+) terminal; either one can be used.

3. Connect the ignition pink wire to the rear cylinder coil (-) terminal. The blue wire connects to the front cylinder coil (-) terminal.
4. Tach connection - attach the pink wire from the tach to the ignition green wire with the large (.250) blade connectors. If there is no tach, fold the wire back into the harness sleeve.
If the bike had only one pink (or pink/black) wire at the coil, connect this to the ignition's green wire.

Do not connect the ignitions tach wire to the coil or damage to the ignition may result.

5. Remove the wire from the VOES (Vacuum Operated Electric Switch). Connect the ignition purple wire with the small (.187) receptacle terminal. If the VOES is not installed, see the tuning tips on the last page. On all **Ultima Engines**, we do not recommend using the VOES switch.

If there is no tach, the green wire can be folded back and tucked into the harness sleeve. The unused stock wire harness can be removed to taped up.

• CONFIGURING THE MODE SWITCHES

This ignition has 6 mode switches which allow you to configure the ignition for your engine build and riding style. The switch position label is located on the ignition for future reference.

Switch 1	V.O.E.S.	Description	
OFF	Normal	(NO VOES) - Follows preset curve shown in chart for specific engine configurations when VOES wire is not used - (low vacuum curves) DO NOT ground VOES wire for these curves. Use this setting for Ultima engines. (USING VOES) - Allows timing to reach full advance by 1500 rpm under light engine load conditions, improving throttle response and gas mileage when the VOES is present. Wide open throttle follows selected pre-set curve. (high vacuum curves)	
ON	Retard	Uses the V.O.E.S. wire to retard timing for nitrous or turbo equipped bikes. See below for further explanation.	
Switch 2	Switch 3	Advance Curve	Description
OFF	OFF	Curve 1 -	This curve brings up the advance the earliest and to the highest final value (most aggressive). Used on 80 and 96Ci engines.
ON	OFF	Curve 2 -	This curve brings up the advance a little slower than curve 1. Used on 100 and 107Ci configurations.
OFF	ON	Curve 3 -	This curve is good for hi compression engines and Ultima 113, 120 and 127Ci, advance comes in slower than curve 2 and to a lower final value.
ON	ON	Curve 4 -	This curve should only be used if your 120 or 127 Ci still detonates using curve 3 and on all 130 and 140 Ci engines. Advance is brought in still slower and to a lesser final value than curve 3 (least aggressive).

The proper advance curve will be determined by the level of engine modification, weight of bike and rider, gasoline octane rating, air temperature, altitude, etc. If you experience any "pinging", use a less aggressive curve. Generally, you should run the curve that is most aggressive without causing pinging.

Switch 4	Switch 5	Rev Limit	Application
OFF	OFF	5500 RPM	All Ultima engines
ON	OFF	6000 RPM	modified Ultima engines
OFF	ON	6500 RPM	(most Harley valve trains don't like to be revved this high)
ON	ON	7000 RPM	
Switch 6	Firing Mode		
OFF	Dual Fire		
ON	Single Fire		

• STATUS LED FUNCTION

The red status LED is used for verifying system operation and setting timing. When power is turned on, the LED should blink for 1/4 second. If the pickup is near a firing point, the LED will blink, then stay on. This indicates the unit has passed its self test.

If the status LED flashes rapidly when the engine is not running, an over-current or short circuit fault is indicated. Check for proper coil resistance (2.5 to 3.5 ohms) and wiring. Correct the problem, then turn the ignition off for one second, then back on to clear the fault.

As the engine is cranked over, the LED will blink indicating the pickups are generating timing pulses. The pick up is designed such that the LED will come on at about 45 degrees before top dead center and go off at top dead center for each cylinder. This corresponds to the leading edge of the window in the rotating cup (45 BTDC) and the trailing edge (TDC).

• STATIC TIMING THE MOTOR

Remove the timing inspection plug. With the bike in high gear turn the rear wheel to get the crankshaft to top dead center on the **compression** stroke of the front cylinder (TDC mark aligned in the inspection hole). Removing the spark plugs will make it easier to turn the crank.

Rotate the ignition to cause the status LED to turn off and on. Carefully follow this next instruction: find the point where the LED just turns off while rotating the base plate in a clockwise direction. Lock down the ignition. The initial timing is now set close to optimum. Final timing may be checked and set dynamically to compensate for normal production tolerances in the timing rotor, camshaft indexing, flywheel marking, etc.

If the ignition has to be rotated an extreme amount or does not have enough adjustment to bring the timing in, the engine may be on its exhaust stroke. Remove the ignition and observe the timing rotor. The timing pickup (near the switches) should be sitting in one of the windows with the ignition installed. The shorter distance to the other window should be CLOCKWISE. If not, rotate the crankshaft 1 revolution and check again.

• DYNAMIC TIMING

To set the ignition timing dynamically (with the engine running), use the following procedure:

- Verify what advanced timing mark is on your flywheel.

Stock HD - 35°

Ultima 80 thru 113 Ci - 30°

Ultima 120, 127, 130 and 140 Ci - 25° (all pre 2006 Ultima 120-127 Ci had 30° advance timing marks)

- Select the curve that will produce the correct total timing for your engine configuration (see chart on last page) by changing switch 2 and 3 to proper selection.

- Grounding the VOES wire will cause the ignition to get total advance by 1500 rpm. Connect a timing light to the front cylinder plug wire.

- Rev the engine above 1500 rpm. The full advance mark should come into view. This will verify the ignition is set properly. Now reset the DIP switches for the mode you want to run.

NOTE - when the switch settings are changed, the power to the module must be turned off and back on for the new settings to take effect.

NOTE - **Dial back timing lights** use the T.D.C. mark for reference and timing is read off the light. On all bikes it is easier to reference the T.D.C. mark and advance timing marks to the alternator rotor so oil will not affect viewing the flywheel marks.

• VOES/RTD LED FUNCTION

The green VOES/RTD LED lights when the violet wire is grounded. With the ignition in normal mode and the VOES connected, the green LED will be on most of the time (engine vacuum present). In Retard Mode, the LED can be used to check operation of the retard controller. (See RETARD MODE USING THE VOES WIRE below.)

• V.O.E.S. SWITCH (NOT RECOMMENDED ON ULTIMA ENGINES)

VOES switches sense partial throttle openings (high vacuum) and open throttle (low vacuum) conditions in the intake manifold. All late model Harley-Davidson engines incorporate a Vacuum Operated Electric Switch (VOES) in the intake manifold to sense the engine load. During part throttle operation when manifold vacuum is high (i.e., light engine load), the switch closes, grounding the violet wire and causing the timing to advance more rapidly.

This improves gas mileage at cruising speeds and provides crisper part-throttle response while preventing detonation during heavy engine loading. Over the last few years switches are being produced that activate at a higher manifold vacuum and are required on larger cubic inch engines. If you use VOES switches on large cubic inch engines your manifold vacuum is much higher and will require a non stock type VOES switch that activates at a higher vacuum. VOES switches should be used on Ultima Engines **by experienced tuners only**.

• RETARD MODE USING THE VOES WIRE

This mode provides a convenient ignition retard for nitrous or turbo equipped bikes. When switch 1 is ON, the violet wire acts as a retard trigger. To use this function, the violet wire is connected to a switch or relay that will ground it at the desired time. The violet wire should not be connected a VOES when set for retard mode.

When activated, timing will be limited to 25 degrees regardless which advance curve is selected. When the violet wire is not grounded, timing will follow the quick version of the selected advance curve. The following chart indicates how much retard can be achieved:

<u>Curve#</u>	<u>Final Timing for Curve</u>	<u>Final Timing with Retard Activated</u>	<u>Total Retard</u>
1	34 degrees	25 degrees	9 degrees
2	34 degrees	25 degrees	9 degrees
3	32 degrees	25 degrees	7 degrees
4	29 degrees	25 degrees	4 degrees

• TUNING TIPS - ADVANCED

Occasionally, best performance may fall somewhere between the curves programmed into the ignition. By rotating the module clockwise (advanced) or counter-clockwise (retarded), the entire curve will be shifted up or down. Be aware that if you advance the ignition, your final timing will be increased. Excessive advance may cause pinging and hard starting, so only turn the ignition one or two degrees at a time and note any changes to the motor.

For racing applications, the advance can be set to always come in quickly by using NORMAL VOES mode and permanently connecting the violet wire to ground. These curves are similar to what is generated by a mechanical advancer.

DUAL-FIRE/SINGLE COIL WIRING DIAGRAM

COILS:

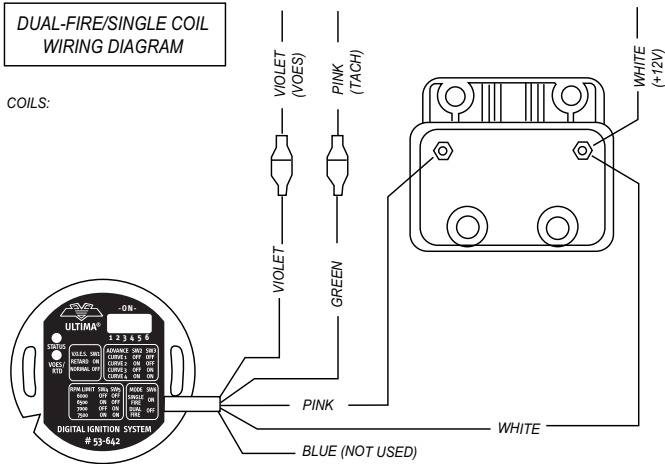

SINGLE-FIRE/SINGLE COIL WIRING DIAGRAM

COILS: 2.5 - 3.5 OHM

NOTE:
OUTPUTS CAN BE REVERSED
FOR BEST SPARK PLUG WIRE
ROUTING BY SWAPPING PINK
AND BLUE PRIMARY
CONNECTIONS.

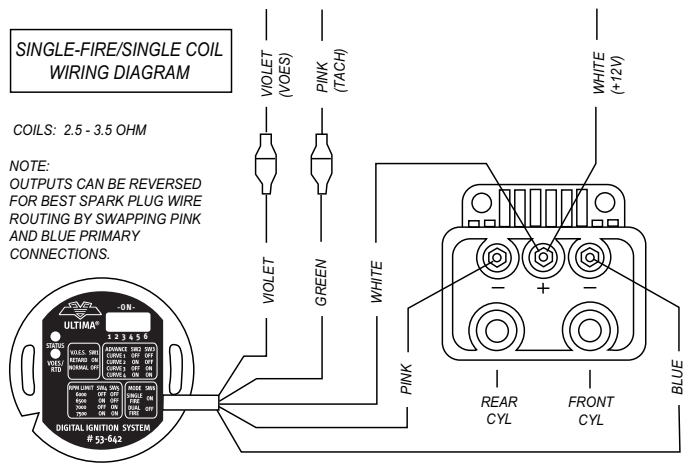

DUAL-FIRE/DUAL COIL WIRING DIAGRAM

COILS:

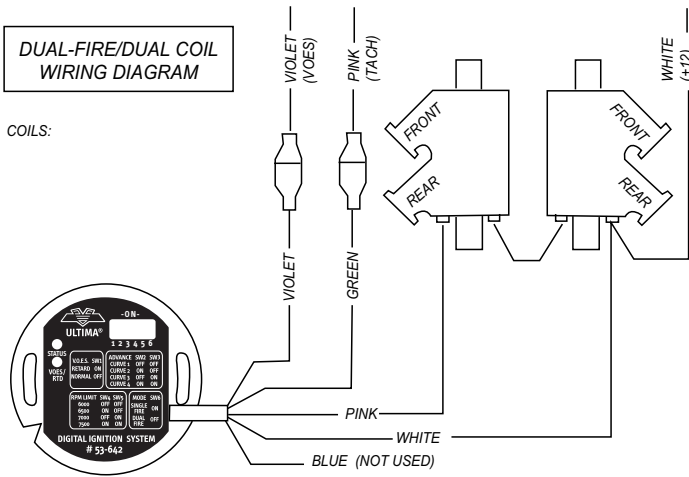

SINGLE-FIRE/DUAL COIL WIRING DIAGRAM

COILS: 2.5 - 3.5 OHM

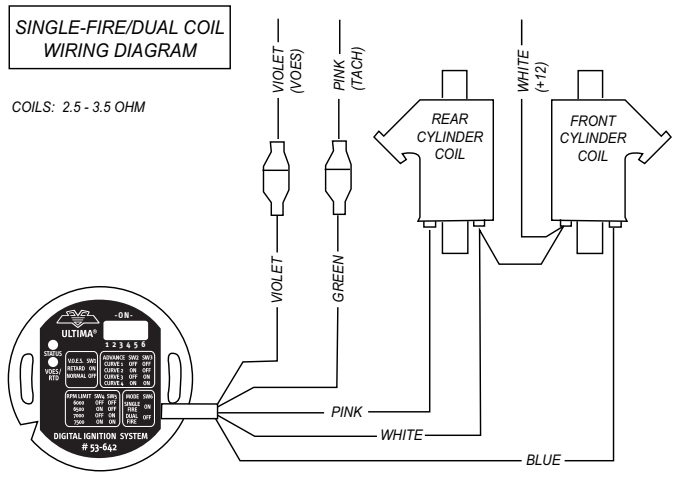

NORMAL VOES MODE ADVANCE CURVES

KEY
 ----- HIGH VACUUM CURVES (VOES) ACTIVATE
 ——— LOW VACUUM CURVES (VOES) OFF (OR NO VOES PRESENT)

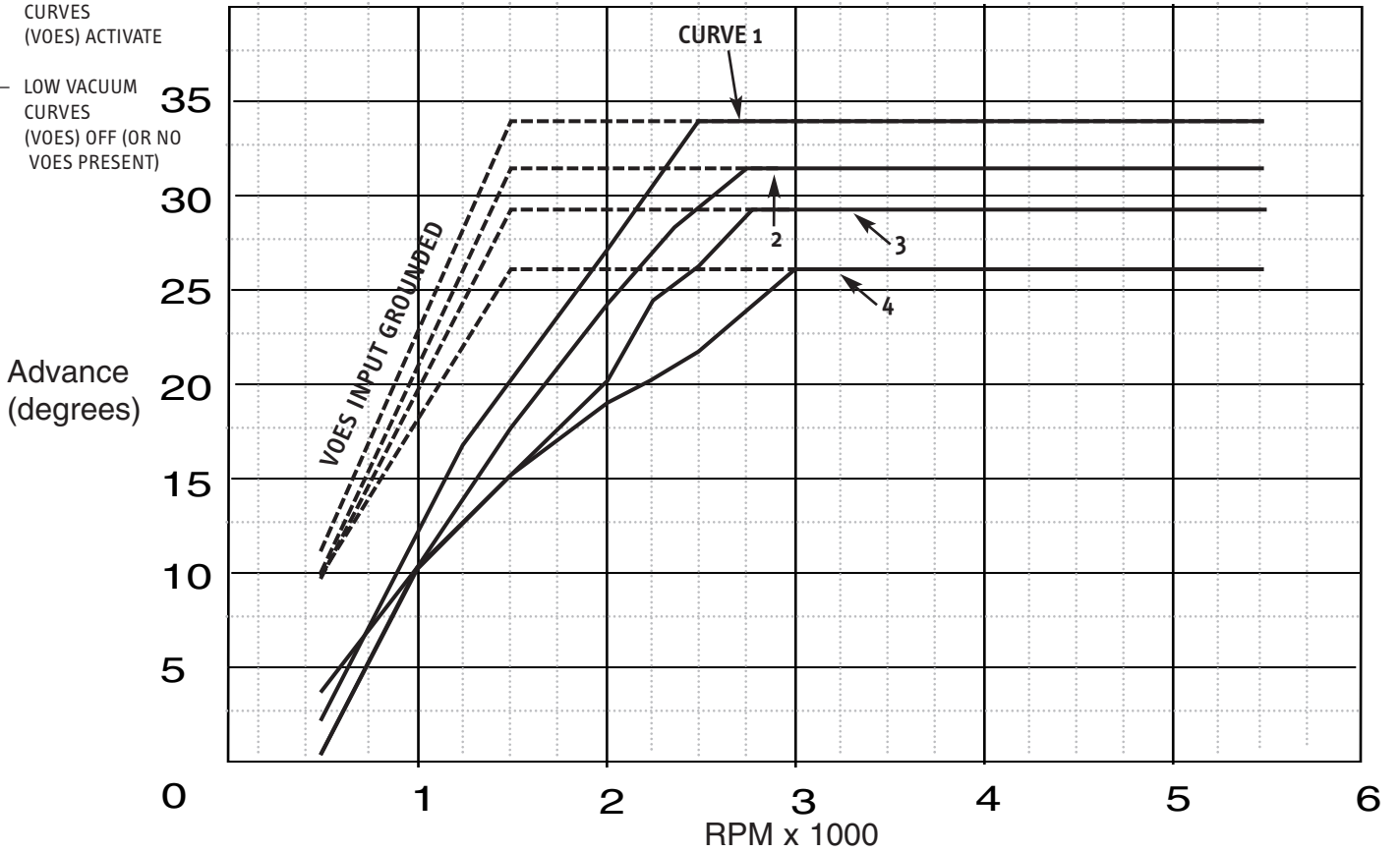

RETARD MODE ADVANCE CURVES

