

DECO

**POWER
LIFT
Inc.**

**ULTIMATE POWER
LIFT
OWNERS MANUAL**

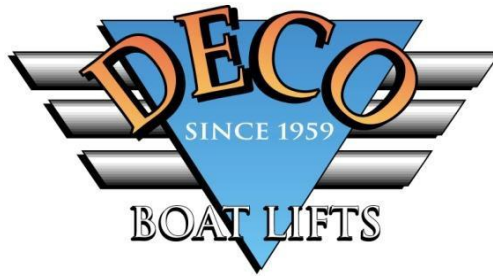

INTRODUCTION

Congratulations on your purchase of a DECO Power Lift, Inc. system. We appreciate your business and want you to know you have purchased the finest lift available. This owner's manual is designed to provide vital information on safety, operation, maintenance and warranty of your new lift. Models covered in this owner's manual include 4,000 to 40,000 lb lifting capacity systems. Your Model Number/ Serial Number (stamped on the gear box housing located on the upper beams) is recorded below. To **ACTIVATE YOUR FACTORY WARRANTY** coverage, please take a moment to complete and return your warranty card. The warranty card is attached to the inside cover of your owner's manual.

Model Number/ Serial Number: _____

Retain this manual for future reference about your Lift system. Additional information on initial setup, troubleshooting, maintenance, **ELECTRICAL WIRING SPECIFICATIONS**, and a packing list is included in the appendix for your reference. For more detailed information on these topics or other technical information please contact DECO Power Lift, Inc. direct by calling (727) 736-4529. For a list of optional equipment on your dock and DECO Boat Lift please visit our website at **WWW.DECOBOATLIFT.COM**.

Thank you for your purchase, and please let us know if we can be of further assistance.

Sincerely,

Richard P. Massell
President
Deco Power Lift, Inc.

IMPORTANT:

- Read this manual carefully before operating your cradle lift.
- **Your cradle lift is not intended for human lifting.**

TABLE OF CONTENTS

	<u>Page</u>
OPTIONAL EQUIPMENT	1
PERSONAL SAFETY	
Things to NEVER Do	2
Things to ALWAYS Do	2
Other Safety Precautions.....	2
INITIAL SET UP	
Chock Positioning.....	3
Guide-on Position	3
Boat Positioning On Cradle	3-4
OPERATING INSTRUCTIONS	
Lowering the Cradle and Launching the Boat	4
Parking the Boat and Raising the Cradle	5
Operating Wireless Remote Control Unit (optional equipment).....	6
PWC Operation.....	6
MAINTENANCE INSTRUCTIONS	
Routine Lubrication	7
Routine Maintenance	8
Maintenance Wireless Remote Control	8
Elevator Maintenance	8
PWC Maintenance	8
WARRANTY	9
APPENDIX	
Appendix A: Trouble Shooting.....	10
Appendix B: Maintenance Check-List.....	11
Appendix C: Electrical Wiring Specifications.....	12-19
Appendix D: Packing List.....	20
Appendix E: Motor Installation / Replacement	21

WIRING TABLES

Table 1: Motor Specifications	12
Table 2: Wire Size for 110 and 220 Volt Single Phase Circuits.....	13
Table 3: Wiring Connections for 220 Volt Single Phase Circuits.....	13
Table 4: Wiring Connections for 110 Volt Single Phase Circuits.....	14
Table 5: Brake Motor Wiring Connections for 220 Volt.....	14
Table 6: Wiring Connections for AO Smith to Gem Remotes	15
Table 7: Gem Remotes Auto-Stop Limit Switch Set-up	16
Table 8: Wire Size for 120 and 240 Volt Single Phase Circuits for TEC Remote Controls	17
Table 9: Wiring Connections for 120 and 240 Volt Single Phase Circuits for TEC Remote Controls....	18
Table 10: TEC Remotes Auto-Control Limit Switch Set-up	19

OPTIONAL EQUIPMENT

1. **ALUMINUM STERN PLATFORMS** - The stern platforms are used for easy access, maintenance and flushing of the engine and lower unit. The stern platforms are highly recommended with outboards and inboard/outboard motors.
2. **ALUMINUM WALK WAYS** - The walkways provide a work platform down the side of the boat or Jet Ski for easy access, maintenance, and cleaning. Walkways are available in lengths ranging from 10'- 24'. **CUSTOM STAIRS** that attach to the walkways are available for boats that are difficult to board. Stairs are available in heights ranging from 2'- 5'.
3. **CABLE RETENTION SYSTEM** – This patented feature is added during the manufacturing of the lift providing solutions to cables overlapping or nesting, which can damage cables. This system features a deep grooved cable winder and molded plastic retaining device that protects and secures the lift cables within the grooves.
4. **WIRELESS REMOTE CONTROL PANEL** - This unit contains a control box on the dock and a hand-held remote control, which will raise and lower the lift up to a distance of approximately 50-100 feet. An auto-stop feature can also be added to this unit.
5. **STAINLESS STEEL MOTORS** - The ultimate protection for electric motors in the marine environment is a stainless steel motor housing. Virtually eliminates rust and corrosion.
6. **ALUMINUM FISH CLEANING TABLE** – The all aluminum fish table, with a brown powder coat finish, features a polymer cutting top insert with a wet-top valve controlled water spray to keep the cutting surface clean. The debris flows into the front tray and down the support leg into the water under the dock. The table is designed to save dock space by mounting on the edge of the dock and extending out over the water. Fish Cleaning Table dimensions: 54” L x 22.5” W x 36” H.
7. **SLIDING STEP LADDER** – 7' extended/ 2' retracted marine grade aluminum step ladder. Maximum capacity of 250 lbs. When in the up position the bottom of the ladder is out of the water to prevent barnacles and other marine growth.
8. **ALUMINUM DOT RAILINGS** - Constructed of marine grade 2” diameter aluminum tubing with 2”x 2” box stanchions in 36” and 42” heights. Adaptable to top mount or side mount applications. Meets or exceeds all building code requirements.
9. **ALUMINUM GANGWAYS** – 3'- 5' widths constructed of marine grade bleacher plank with side railings, mounting hinge plate and rollers, optional handicap accessible features; include transition plate, and safety traction ridges for added protection.
10. **CUSTOM ACCESSORIES** - Custom aluminum accessories including stairs, access ramps, catwalks, and safety hand-railings, are available upon request. Custom accessories are manufactured to meet customer requirements.

PERSONAL SAFETY

NOTE: The following personal safety precautions have been developed based on previous customer experiences. Reading and understanding these recommendations can prevent *Personal Injury or Property Damage* while using the Ultimate Power Lift system. **DO NOT MAKE THE SAME MISTAKES.**

I. Things to **NEVER** Do

1. NEVER ride in the boat while it is being lifted. The lift is not intended for human lifting. Remove people and cargo before raising the boat.
2. NEVER leave the lift running while unattended. Damage and/or injury could result.
3. NEVER operate the lift while people are under, near or standing on the lift.
4. NEVER load the lift beyond the factory specified lifting capacity.
5. NEVER allow the boat to fill with water. Water increases the total lifting weight which may exceed the capacity of the lift. Empty before lifting.
6. NEVER leave the lower cradle in the water. Electrolysis can cause structural damage.
7. NEVER allow lifting cables to wrap on top of each other or damage to the cable will result.
8. NEVER leave the stern of the boat hanging more aft than approximately 4 ft. from the lower rear beam. The center of gravity of the boat should be centered on the lower cradle. This will depend on the type and weight of the boat being lifted (See initial set up section).
9. NEVER use Stern Platforms (optional item) while the lift is empty. Stern Platforms are designed for use when your boat is ON THE LIFT.
10. NEVER use the Walkways (optional item) while the lift is empty. Walkways are designed for use when your boat is ON THE LIFT.
11. NEVER power boat onto the lift. If there is not enough water to float boat onto lift, WAIT for a higher tide.

II. Things to **ALWAYS** Do

1. ALWAYS keep hands away from all moving parts.
2. **ALWAYS turn main power supply to the lift OFF when not in use.**
3. ALWAYS watch the boat as it rises to be sure of proper placement of the boat on the lift. Lower and reposition if required.
4. ALWAYS raise lower cradle beams above the high tide water level.
5. ALWAYS inspect lifting cables for damage or frays. If problems are found, replace cables immediately.

III. Other **Safety** Precautions

1. For use by adults only.
2. The transmission ranges of the Wireless Remote Control units (optional item) can fluctuate and the lift can be **ACCIDENTALLY** started with the hand-held remote or may be triggered by another remote and require re-coding. Do not allow the hand held unit to become wet; **ACCIDENTAL** activation of the lift can occur. Control panel switch should be in OFF position, when the lift is not in use, to prevent *unauthorized* or **ACCIDENTAL** operation.
3. Regular maintenance will insure the safety, performance and longevity of the Ultimate Power Lift system.

INITIAL SET UP

NOTE: Initial set up of both the lift and proper positioning of the boat on the lift is crucial for safe, long-term operation of the lift. Positioning of chocks, bunks, guide-ons, and boat on the lift should be set by the installer and checked by the owner. The installer should be present with the owner on the initial lift to insure safe operation and proper boat positioning.

I. Chock Positioning

1. The forward two chocks and the rear two chocks should be the same distance away from the center of the front and back lower cradle beams, respectively. This will result in the boat being centered (port to starboard) on the lower cradle.
2. The chocks should be set near/under the main support stringers of the hull. Typically, these stringers coincide with the chines under the boat. Initial separation of the chocks used by many installers is 30 inches in the front and 36 inches in the rear.
3. Do not position the chocks directly under the chine. The chock should be set just inside or just outside the boat chines.
4. Do not position chocks under through hull fittings. Damage to the boat can result if the chocks contact through hull fittings.
5. When conditions of low water exist, spread chocks so the center of hull is as close as possible to the lower beam (without contacting beam).

II. Guide on Positioning

1. The Guide-ons should be centered on the lower cradle, which will result in the boat being centered (port to starboard) on the lower cradle. Guide-ons and chocks must come off the same center.
2. Guide-on spacing on the lower cradle should be set to the beam of the boat. Guide-ons should be **SNUG** (not tight) along the sides of the boat to ensure proper positioning of the boat on the cradle and chocks.

III. Boat Positioning

1. **SLOWLY** position the boat using the PVC Guide-ons over the cradle. Always float the boat over the lift (never power on the lift). The **CENTER OF GRAVITY** of the boat should be centered between the fore and aft lower cradle beams. This position of the boat on the cradle will depend on the type and weight of the boat being lifted.

NOTE: Physically feeling the tension in the front and rear cables is an easy way to determine if the boat needs to move forward or backward in the lift. With proper positioning, the cable should feel the same. As a general rule, never leave the stern of the boat hanging aft more than approximately 4 ft. from the rear lower beam.

2. The PVC guide-on can also help guide the boat fore and aft into the proper lift position. When the boat is in the proper position fore and aft (see note above) take a visual bearing of the location of a guide-on in relationship to a cleat or marking on the boat. Use this marking for future reference and always return to this center of gravity location when lifting the boat.

3. It is important to establish a reference point with electrical tape to know when you have submerged the cradle to a sufficient depth to get your boat on/off the lift. Begin by lowering the cradle until the boat floats. Then mark the PVC guide-on at the water line with electrical tape. Now, when the lift is lowered to the tape mark your boat will float both on and off the lift. Continue lowering the lift (slowly) until the lower cradle hits bottom, stop, and raise the lift six inches. Mark cable at winder with electrical tape to establish a reference point **warning** that the lower cradle will hit bottom and cables will lose tension.
4. Proper positioning of the boat includes making sure the water will drain to the back of the boat and bilge pump. This is accomplished by slightly raising the front of the boat. The cables are shipped from the factory with a minimum two inch pitch. The installer can further adjust the cables to raise the front lower beam. In addition, the two front chocks/bunks can be moved closer together to increase the pitch of the boat for proper drainage.
5. **Elevator Boat Positioning:** The key factor regarding operation and safety is proper boat positioning. The “center of gravity” (CG) of the boat must be located in the center of the lift cradle beams, however every boat is different. Typically, the CG is just behind the steering station. Proper boat position fore and aft is critical in Elevator Lift operation. If you are uncertain where your CG is, contact the boat manufacturer. Typically, the transom of the boat should not protrude over four feet past the rear lower elevator lift beam.

OPERATING INSTRUCTIONS

NOTE: Read the Personal Safety section of this manual before operating the lift. Always inspect cables, belts and sheaves (pulleys) for deterioration, damage, and required maintenance each time the lift is used. If the lift has sat idle for more than two months, a thorough inspection and lubrication is required before operating the lift.

I. Lowering the Cradle and Launching the Boat

1. Inspect lifting cables, belts and sheaves (pulleys) for deterioration, damage, and required maintenance prior to operating the lift. If needed, install the boat drain plug and remove boat shore power cables.
2. Confirm that both lift motor manual switches are in the OFF position.
3. Turn main power or dock power ON.
4. Confirm the Ground Fault Interrupt (GFI) protector, on the main power supply or control box, is not “tripped”.

NOTE: The GFI protector is to provide protection against GF electrical shocks. The GFI device will “trip” if an imbalance has occurred. Once the GFI has “tripped”, you will need to manually push the reset button. If the imbalance condition has cleared, power will then be restored to the motors on your boat lift.

5. Using the two manual switches, **SIMULTANEOUSLY** lower the boat and cradle into the water until it floats.
6. Slowly back the boat completely off the lift.
7. Raise the cradle up out of the water. This will prevent deterioration of the cradle from corrosion and electrolysis. Electrolysis can cause structural damage.

II. Parking the Boat and Raising the Cradle

1. Remove people and cargo from the boat.
2. Using the two manual switches **SIMULTANEOUSLY**, lower the cradle into the water. Submerge the lift sufficiently so the boat will **FLOAT** over the cradle and chocks (never power on).

To know when you have submerged the cradle to a sufficient depth, lower the cradle until the boat floats. Then mark the PVC guide-on at the water line with tape.

NOTE: To maintain tension on cables and prevent tangling use the following guidelines:

- **DO NOT** allow lower cradle to touch bottom.
- **DO NOT** add wood to aluminum cradles. Wood causes the cradle to float.

NOTE: The PVC guide posts can also help guide the boat fore and aft into the proper lift position. Take a visual bearing of the location of the PVC guides to a cleat or mark on the boat for future reference. Always return to this center of gravity location. As a rule of thumb, the transom of the boat should not protrude past the rear lower beam more than four feet.

3. Position boat in proper place fore and aft. (see initial set-up section)
4. Turn both motors switches **ON** until the weight of the boat is on chocks.
5. Turn both motors switches **OFF** and inspect the chocks to insure the boat is aligned properly. If out of position, lower and readjust.

NOTE: Chock position should be set by the installer and is dependent on the type of boat being lifted. Do not allow the chocks to be under through hull fittings or on hull chines.

6. Continue lifting to a minimum of 1 foot above the high tide water level. Never leave the lift running while unattended. Damage and/or injury could result. Do not leave the bottom of the lift in the water.

NOTE: The installer will configure the lift with the front of the boat slightly raised so water will drain out the back of the boat. This can be done by moving the two front chocks closer together or by adjusting the cables to raise the front lower beam approximately 2 inches higher than the rear lower beam.

7. Cover the boat to prevent rain water from collecting in the boat. Water increases the total lifting weight which may exceed the capacity of the lift.
8. Turn the main and dock power supply **OFF** to the lift when not in use to prevent accidental or unauthorized use.
9. Rinse the lift off with fresh water after each use.

III. Operating Wireless Remote Control Unit (optional equipment)

NOTE: Wireless Remote Control units (optional item) transmission ranges fluctuate and the lift can be **ACCIDENTALLY** started with the hand-held remote. **ACCIDENTAL** activation of the remote can be caused by the following:

- Placing objects on top of the remote.
- Spraying the remote with water.
- Placing the remote in your pocket.

1. DECO recommends that the hand-held remote be kept in a secure place, away from direct sunlight and in a zip lock bag (to prevent the unit from becoming wet). **Do not store on the boat!**
2. Follow the operating procedures from section I and II using the momentary button located on the control box, or the hand-held remote to operate the lift motors. One button operates both motors.
3. **FROM THE DOCK** use the hand-held remote for lifting and lowering the cradle with the boat.
4. **FROM THE BOAT** use the hand-held remote for both lifting and lowering the cradle only.
5. Use the following procedure for leveling the lift from Port to Starboard on a two motor lift:

- First turn off the Auto-Stop Switch (if equipped). Hold the level switch down. This will turn OFF one motor.
- At the same time, press the UP or DOWN button as required to level lift. The water surface is level and can be used as a comparison to level the lower cradle beams. When level, let the lift come to a complete stop then release the level switch.
- **DO NOT** turn the level switch ON or OFF while the lift is moving.

6. Always turn OFF main power to your wireless remote control system. This will prevent others from operating the system without your knowledge and accidental power starts from the hand-held remote. Do not store hand-held remote on the boat.
7. Optional Feature: **Auto Stop Remote Control**. This feature gives the lift operator the ability to pre-set the upper and lower travel distance of the lift. Once set, the operator pushes the up or down button once, and the lift will travel to the predetermined position. You must have a limit switch and an Auto Stop equipped Remote Control Unit. To add this feature, contact DECO's Parts Department (727) 736-4529.

IV. PWC Operation

1. The PWC Lift comes with an UP/DOWN momentary rope switch. To prevent damage to the switch, do not pull hard on the rope or damage to the switch will occur. Avoid running lift to the ground to prevent cables from un-spooling. Refer to pages 3-4 of the Owner Manual on Boat Positioning. Do not raise lift up beyond stop point. This will cause the mast to jam and cause potential damage to the lift. For safety, **ALWAYS** keep hands and feet away from all moving parts on the lift.

MAINTENANCE INSTRUCTIONS

NOTE: Your DECO Ultimate Power Lift system is designed and manufactured to provide long life in a corrosive marine environment. However, the lift requires regular maintenance to insure the lift's safety, performance, and longevity. Routine maintenance will keep the lift operating at peak performance. Failure to regularly maintain the lift could result in system failure, personal injury, and damage to the lift and boat.

The following materials are needed for routine maintenance:

- Lubricating Spray
- Grease Gun and Waterproof Grease (use a Marine grade or lithium grease)
- Rust Resistant Spray Paint

These materials are available at most retail marine supply stores.

I. Routine Lubrication

NOTE: All areas requiring lubrication should be maintained annually and sometimes more frequently depending upon use of the lift and the part(s) being serviced.

1. **WINCH:** (DECO, CONCEPT, and BEAMLESS Models) the Gear box is totally enclosed in a sealed oil bath. There is a grease nipple located on the back of the gear box, where the drive pipe enters, that should be greased annually.
2. **WINCH:** (MAXI Model) The large gear under the white cover should be lubricated on a monthly basis with a marine waterproof grease. All grease fittings on the plate drive should also be greased.
3. **PILLOW BLOCKS:** The Pillow Blocks through which the Torque Tube drive runs should be lubricated on a yearly basis with a marine waterproof grease.
4. **SHEAVES:** Once a month grease or spray a waterproof lubricant on the Sheaves and stainless steel bolts that the Sheaves turn on.

II. Routine Maintenance

1. LOWER CRADLE: A fresh water rinse should be done after each lift. Hose off lower cradle including sheaves and cables and confirm that no floating debris was picked up during the lifting process.
2. CABLES: Cables have a limited operating-life and, depending upon usage, will need to be periodically replaced. Inspect cables and fittings monthly for any signs of rust, wear, **fraying** or damage. If any of these signs appear **replace cables immediately** to insure safe operation of your lift.
3. SHEAVES (Pulleys): Check tightness of sheave nuts every six months (do not over tighten, sheave must spin freely). Remove and examine sheaves for wear on a yearly basis. Replace if necessary.
4. MOTORS: Electric motors are not rust proof (see optional Stainless Steel motors). Paint motor housings with a rust inhibitor paint as needed.
5. FULL LENGTH BUNKS: Bunk boards and carpet will need periodic replacement which is dependent on usage. Visually inspect for splits or cracking in wood and deteriorated carpet.
6. BELTS: Check motor/ Gear box belt tightness every six months. See Appendix E for Motor installation.

III. Maintenance Wireless Remote Control

1. The DECO Power Lift wireless remote control unit is a self contained water tight unit. No maintenance is required. ALWAYS turn the power off when not in use to prevent ACCIDENTAL actions of the unit. DECO recommends that the hand-held remote be kept in a secure place, away from direct sunlight and in a zip lock bag (to prevent the unit from becoming wet). Do not store on the boat.
2. Ground Fault Interrupt (GFI) protector should be tested once a month or before every use.

IV. Elevator Maintenance

1. Periodically inspect the zinc anodes for deterioration. Periodic zinc replacement is required, to prevent stray electrical current in the water from deteriorating/corroding aluminum rails. Replace zinc anodes when 75% is gone. To purchase zines, contact DECO's Parts Department at (727) 736-4529 for exact replacements. When not in use, turn off and disconnect power to lift using a dockside electrical disconnect. Disconnect all electrical power, including Ground and Neutral, to prevent damage to aluminum lift tracks by stray electricity or electrical surges.
2. Periodically inspect the aluminum tracks where the rollers travel for marine growth or any obstructions. Remove any visible debris from the tracks so the rollers travel free of any obstructions.

V. PWC Maintenance

1. Periodically, at least twice a year, remove motor cover and apply marine grease to drive gears.
2. Check cables for fraying or wear. If any of these signs appear, replace if needed.

LIMITED WARRANTY: DECO POWER LIFTS, INC.

(Limited 5 and 10 Year Warranty)

DECO Power Lift, Inc., hereinafter referred to as “the company”, expressly warrants the main support member’s structural integrity of their cradle lift system to the original purchaser at the property where the lift was installed for 10 years for aluminum lifts and 5 years for galvanized lifts while retaining ownership; Elevator Lifts and Personal Water Craft (PWC) lifts are warranted for a period of 5 years to the original owner at the property where the lift was installed. The company further expressly warrants that its products shall be free from any manufacturer’s defects in material or workmanship for a period of one year from date of delivery by seller. The company agrees to provide all necessary parts, materials, and labor to correct any such defects providing written notice with the original bill of sale or proof of purchase is received by the company within the one year period. All warranty repairs must be performed by a factory authorized representative. To **ACTIVATE FACTORY WARRANTY**, the enclosed warranty card must be completed and returned to the company.

The purchaser’s remedy is limited to repair or replacement of the defective part. The company’s address for receipt of notice is: **DECO Power Lifts, Inc.**

**1041 Harbor Lake Drive
Safety Harbor, FL. 34695**

Any of the following shall void manufacturer’s warranty:

- Product is installed at any location other than set forth in the sales agreement.
- Product is used in a commercial manner.
- Product is used other than in accordance with the recommendations set forth in the installation and owner’s manuals.
- Product has been altered or modified after delivery.

The company does not accept liability ensuing from improper use or installation of its products. This warranty does not extend to the cables, chock boards, drive pipes, electric motors, or sheaves after one year. This warranty does not extend to products that have been subject to misuse, over loading, accidental damage, misapplication, or damage caused by electrical surges.

NO REPRESENTATIVE OR OTHER PERSON IS AUTHORIZED TO ASSUME FOR THE COMPANY ANY ADDITIONAL LIABILITY IN CONNECTION WITH THE SALE OF ITS PRODUCTS OR TO ALTER THIS WARRANTY IN ANY WAY. OTHER THAN AS SET FORTH ABOVE, THE COMPANY MAKES NO EXPRESS OR IMPLIED WARRANTY (INCLUDING IMPLIED WARRANTIES OF MERCHANTABILITY AND FITNESS) RELATING TO THE PRODUCT. FURTHER, THE WARRANTY IS LIMITED TO CORRECTION OF THE DEFECTIVE PART; THE COMPANY SHALL NOT BE RESPONSIBLE FOR ANY CONSEQUENTIAL DAMAGES RESULTING FROM ANY SUCH DEFECTS.

APPENDIX A: TROUBLE SHOOTING

Trouble	Cause	What To Do
Motor fails to start.	<ol style="list-style-type: none"> 1. Blown circuit-breaker at main power box. 2. Blown circuit-breaker on GFI. 3. Defective capacitor (motor hums). 	<ol style="list-style-type: none"> 1. Reset fuse. 2. Reset fuse. 3. Change motor capacitor, or check capacitor connections.
GFI circuit-breaker will not reset.	<ol style="list-style-type: none"> 1. Water in the GFI or electrical system. 2. Short in electrical wiring. 	<ol style="list-style-type: none"> 1. Dry or replace. 2. Contact a licensed electrician.
Lift coasts after being turned off.	<ol style="list-style-type: none"> 1. Improper belt tension. 	<ol style="list-style-type: none"> 1. Tighten or replace belt.
Direction of lift is opposite from posted markings.	<ol style="list-style-type: none"> 1. Motor is wired incorrectly. 2. Cables are wound in reverse. 	<ol style="list-style-type: none"> 1. Check connections with diagram supplied with motor 2. Allow lower cradle to fully extend and rewind cables in opposite direction.
Cables do not wind properly or are winding on top of each other.	<ol style="list-style-type: none"> 1. Not enough cable tension when lowering the lift. 2. Lift is out of square/ level. 	<ol style="list-style-type: none"> 1. Add weights to lower beams. 2. Adjust pilings or lift connection to pilings.
Lift motors starts accidentally.	<ol style="list-style-type: none"> 1. Wireless remote is accidentally activated. 	<ol style="list-style-type: none"> 1. Turn main power off to control box when not in use.
Boat and lift are not level.	<ol style="list-style-type: none"> 1. Difference in motor speed. 2. Piling has sunk. 	<ol style="list-style-type: none"> 1. Level lift by starting one motor only. 2. Adjust pilings or lift connections to pilings.
Lower cradle floats.	<ol style="list-style-type: none"> 1. Too much wood has been added to lift. 2. Wave action can lift cradle. 	<ol style="list-style-type: none"> 1. Remove excess wood. 2. Add lead blocks/weight to weight to lower cradle.

APPENDIX B: MAINTENANCE CHECK-LIST

NOTE: DECO recommends the retail customer maintain a maintenance record. The Maintenance Check-List has been provided for your convenience.

Name: _____ Model No./ Serial No.: _____

DATE	MAINTENANCE PERFORMED	COMMENTS

APPENDIX C: ELECTRICAL CONNECTIONS

NOTE: Electrical hook-up must be done by a *licensed electrician*. All wiring must be done according to the National Electric Code and local codes. Wiring that does not meet these standards voids the factory warranty.

Connect power supply of proper voltage to the motors. The ¾ hp motors and control boxes can be wired for either 110V or 220V single phase service. **DECO recommends**, whenever possible, the lift should be wired using 220V single phase service. All (4) motor lifts must be wired 220v single phase. Proper wire size and correct voltage is critical for proper and safe operation of the lift. Wire sizing information can be found in the National Electric Code used by most licensed electricians. Wire sizing is determined by the voltage being brought to the panel, the distance from your power panel, and the amperage required by the panel and by your lift motors to operate. See TABLES 1-2. First, determine your type motors, voltage and operating controls; then find the correct TABLE 3-6 for proper wiring connections. Remote Control boxes have connection diagrams to supplement the following wiring Tables. **DO NOT** use the wiring diagram on the motor nameplate!

TABLE 1: Motor Specifications

Motor Hp.	Motor Type	110/220 Volt	Amp Draw (per motor)	2 Motor Lift Breaker Size	4 Motor Lift Breaker Size
3/4	AO Smith	110	12	35	N/A
3/4	AO Smith	220	6	25	40
1	AO Smith	110	14	35	N/A
1	AO Smith	220	7	25	40
3/4	Marathon	110	11	35	N/A
3/4	Marathon	220	5.5	25	40
1	Marathon	110	14	35	N/A
1	Marathon	220	7	25	40
1	Stainless Steel	110	14	35	N/A
1	Stainless Steel	220	7	25	40

A **GROUND FAULT INTERRUPT (GFI)** protector must be used with each lift to provide protection against GF electrical shocks in the water. The GFI device will “trip” if an imbalance has occurred. Once the GFI has “tripped”, you will need to manually push the reset button. If the imbalance condition has cleared, power will then be restored to the motors on your boat lift.

Elevator Lift Wiring: The Elevator lift must be wired and approved by a licensed electrician. This lift must be wired with a dockside electrical disconnect which disconnects all power, including Ground and Neutral, to the lift.

NOTE: DECO cannot stress too strongly the importance of correct electrical connections. Improper wire sizing can cause the lift to malfunction and may even damage the control box or motors. The following wire sizes are recommended by the National Electric Code.

TABLE 2: Wire Size for 110 and 220 Volt Single Phase Circuits

Distance*:	100 ft.	100 ft.	200 ft.	200 ft.	300 ft.	300 ft.	500 ft.	500 ft.
Voltage:	110V	220V	110V	220V	110V	220V	110V	220V
Motor Hp.	Wire Size	Wire Size	Wire Size	Wire Size	Wire Size	Wire Size	Wire Size	Wire Size
1/2	#10	#12	#08	#10	N/A	#08	N/A	#06
3/4	#10	#12	#06	#10	N/A	#08	N/A	#06
1	#08	#10	#06	#08	N/A	#06	N/A	#04
1 1/2	#04	#10		#08	N/A	#06	N/A	#04

* Distance= Motor to Fuse or Meter box in Feet.

NOTE: Wire size based on (2) motor lifts.

TABLE 3: Wiring Connections for 220 Volt Single Phase Circuits

DECO/Marathon/Stainless Steel Motor Lead Numbers (T)	Furnace Switch (Black)	Bremas Switch (Gray)	GEM Control Box	TEC Control Box
T8	1	T8 (Red)	Red	Red
T4	2	T1 (Black)	Orange	Orange
T1	4	T2 (White)	Black	Black
T2,3,5 (twist together)	-----	-----	-----	-----
-----	A (Power in)	L1 (Power in)	Black (Power in)	Black (Power in)
-----	B (Power in)	L2 (Power in)	Red (Power in)	Red (Power in)
-----	-----	----	White (Neutral in)*	White (Neutral in)*
Ground	-----	----	Green(Ground)	Green(Ground)

NOTE: Use #12 stranded wire between the control box or switches and the motors. Always ground the motor and use a GFCI in the circuit. To reverse motor direction flip output motor leads 5 and 8. *White/Neutral not used on (4) motor lifts using a GEM GR4/GR4A or a TEC TEC4/TEC4 A/C.

TABLE 4: Wiring Connections for 110 Volt Single Phase Circuits

DECO/Marathon/Stainless Steel Motor Lead Numbers (T)	Furnace Switch (Black)	Bremas Switch (Gray)	GEM Control Box	TEC Control Box
T8	1	T8 (Red)	Red	Red
T5	3	T9 (Orange)	White	White
T2,T4	2	T2 (White)	Orange	Orange
T1,T3	4	T1 (Black)	Black	Black
-----	-----	-----	-----	-----
-----	A (Power in)	L1 (Power in)	Black (Power in)	Black (Power in)
-----	B (Power in)	L2 (Power in)	White, Red (Neutral in)	White, Red (Neutral in)
Ground	-----	-----	Green (Ground)	Green (Ground)

NOTE: Use #12 stranded wire between the control box or switches and the motors. Always ground the motor and use a GFCI in the circuit. To reverse motor direction flip output motor leads 5 and 8.

TABLE 5: Brake Motor Wiring Connections for 220 Volt

WARNING: If unsure of how to wire brake motors consult factory. Improper wiring of brake motor will burn up brake or motor.

Brake Lead Numbers (B)	Marathon Motor Lead Numbers (T)	GEM Control Box	Bremas Switch	TEC Control Box
B1	T4	Orange	T1 (Black)	Orange
B2	T1	Black	T2 (White)	Black
	T8	Red	T8 (Red)	Red
-----	T2,3,5(twist together)	-----	-----	-----
B3,4 (twist together)	-----	-----	-----	-----
		Black (Power in)	L1 (Power in)	Black (Power in)
		Red (Power in)	L2 (Power in)	Red (Power in)
		White (Neutral in)		White (Neutral in)
		Green (Ground)		Green (Ground)

NOTE: Use #12 stranded wire between the remote control box or switches and the motors. Always ground the motor and use a GFCI in the circuit. To reverse motor direction flip output motor leads 5 and 8. **BEFORE CONNECTING POWER CALL THE FACTORY TO REVIEW WIRE CONNECTIONS.**

TABLE 6: Wiring Connections for AO Smith to Gem Remotes

AO Smith Motor Wiring

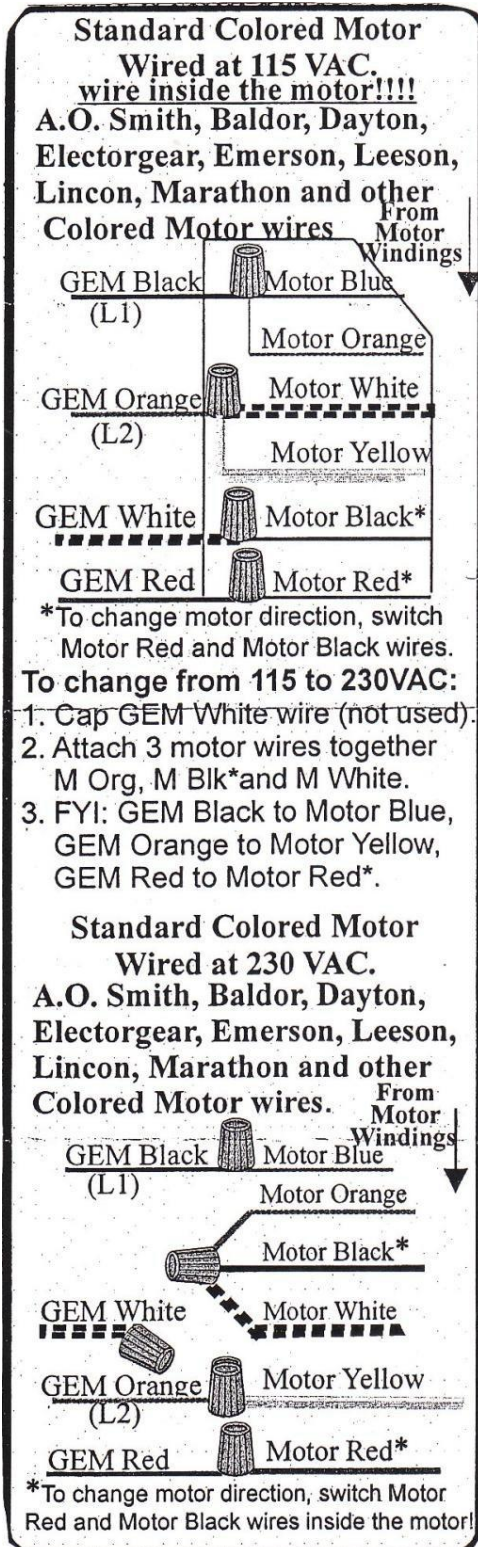

TABLE 7: Gem Remotes Auto-Stop Limit Switch Set-up

GEM Auto-Stop Limit Switch Yellow Top KFLS, KRLS AND KELS Step by Step Procedure

6/17/08

NOTE: Do not attach KFLS (all metal box) a limit switch mechanically until the lift is completely set up and adjusted. Attaching the old limit switch mechanically before the lift is set up can destroy the limit switch and cause it to malfunction.

Tools: Phillips Screwdriver, Small Regular Screwdriver, wire strippers.

1. Turn off main power to dock. Strip limit switch and GEM's units limit switch wires.
2. Bypass the limit switch during an initial setup by connecting (a wire nut) the three limit switch wires together inside the GEM box. It is against code to sell or run an Auto-Stop unit without a limit switch. If your limit switch does not have wires attached, call the boat lift company that sold you the unit. If it is not a GEM limit switch system, it is not covered under warranty or product liability.
3. Note the Auto-Stop LED at the top of the face card. If it is light then press the Auto-stop button and the LED will turn off. You want it off.
4. Check to see that lift goes in right direction on the face card (make sure the tail on the face card is connected) and the remote.
5. Get all motors level and running in the same direction. Place the lift 1 foot from the maximum up position.
6. If installing KFLS on a BHUS or BLUS lift check for clearance of a bolt see next page. When mounting the limit switch, the fork must be parallel to the pipe (in the center). If the fork is not parallel, the limit switch could get damaged and malfunction. On a KFLS remove the two top bolts on the worm gear. Note the holes in the KFLS that match up to the bolts. If your unit has a white plastic backer that covers the nuts undue the top 2 guide pins for the motor cover this should give you more room to work. Some Flat Plate winches have an extra zerk fitting. You can remove it or drill an extra hole in the KFLS plate. For clearance for the motor and limit you might need to drill 2 holes in the top of the motor cover closer to the edge of your cover. Over the years these holes have gotten farther away from the edge and causing interference.
7. Remove Yellow caps by removing two screws (these will be loose from GEM Remotes).
8. Press up on the transmitter and watch the direction that the two cams turn when your lift is at the max height. Release the up button.
9. Now remove the bypass wire nut and connect the wires from the limit switch to the GEM wires. (Black 18 to Black 18, Red 18 to Red 18, & Blue 18 to Blue 18 limit switch wires).

Adjustment Procedures: To adjust the upper limit use screw 2o-2(blue wire on micro switch).

10. Your lift should be at the max height if you followed the directions above. Loosen retainer screw 1o(¼ TO 3/4 TURN) inside the case as shown in the picture below.
11. Adjust the upper limit using screw 2o-2(blue wire). Adjust the screw so the cam hits the micro switch roller arm in the direction the cam was turning. You will hear a small click. If the arm is already on the cam, back it away and adjust until you hear the click.
12. Press the up button. The lift should not turn on. **Re-tighten retainer screw 1o**. Check to see that the Auto-Stop LED is flashing fast.
13. Now press the down button on the transmitter. Watch the cams to see that they travel away from the roller switch arm. If the down switch arm is on the down cam and the unit will not lower go to step 11 and adjust the lower cam away from the roller switch arm.
Always re-tighten the retainer screw (1o) before you activate the lift.
14. When the lift is at the lowest point to be able to launch your boat at a low tide, or before the lift hits bottom, or it has only 3 wraps of cable on the drive pipe, adjust the bottom cam screw (2o -1 red wire) until you hear the click. This should engage the micro switch roller arm. Try pressing the down button on the transmitter. The lift should not turn on; check to see a slow flashing of the Auto-Stop LED.
15. **Re-tighten the retainer screw (1o) before you activate the lift.**
16. Press the Auto-Stop button. The lift should run continuously by pressing a button once. Run the lift up a foot then press the stop button, and the lift should stop. Now the down button(built in 3 second delay when changing direction) make sure the lift stops at the lower limit, if not readjust the limit then test again. Test run the lift in both directions to ensure proper operation **check that the lift stops in the correct positions**. The new 2007 units have a six minute time out, if the lift runs for six minutes, the lift will stop. If you need more time just press the same button again and it will run for another six minutes.

FAILURE to follow these directions voids all warranties to equipment as written or implied. GEM will assume no responsibility to damages that were a result of improper installation or user error.

WARNING: Failure to tighten the retainer screw might not allow the cams to move, therefore the **LIFT WILL NOT STOP**. This could possibly cause damage to the limit switch, boat lift, boat, and/or the entire system.

Read the instructions on the yellow face card. For maximum safety, we recommend that the GEM unit be turned off at the power source when not in use.

Inside the Yellow Limit Switch Box

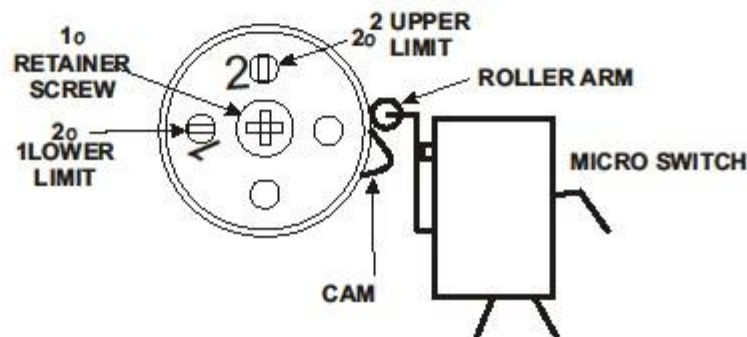

TABLE 8: Wire Size for 120 and 240 Volt Single Phase Circuits for TEC Remote Controls

TEC Boat Lift Controls
3411 Chenunda Drive, Wellsville NY 14895
888-775.0545 or 585-479.8738
www.TECRemotes.com

Having the proper electrical service to your boat lift is critical to satisfactory operation. The Table below is a guide for sizing your service. Note that ALL Local and National Codes must be followed and this guide does not supercede any of those codes.

OVERLOAD PROTECTION IS NOT INCLUDED and MUST BE PROVIDED ON THE LINE SIDE OF THE TEC REMOTE CONTROL

1. Whenever possible the electric service SHOULD be a dedicated circuit.
2. Read ALL wiring instructions and wiring diagrams before connecting or changing wires!
3. Verify the motor wiring with the wiring diagram in the Control enclosure.
4. If you have questions or trouble, shut power off and call us.
888-775.0545 or 585-479.8738

Use this Table as a guide to size the Circuit Breaker and the wire size to your Remote. Measure the distance including any vertical distances. Wire size is based on voltage drops to avoid problems and breaker size listed is based on 250% of motor amps.															
Recommended Copper Wire Size for your TEC Remote															
# of Motors	Motor HP	120 Volt AC Main Feed							240 Volt AC Main Feed						
		Motor Amps	Breaker Size	50 Feet	100 Feet	200 Feet	300 Feet	400 Feet	Motor Amps	Breaker Size	50 Feet	100 Feet	200 Feet	300 Feet	400 Feet
1	1/2	9.4	20	12	10	6	4	4	4.7	10	14	14	12	10	10
	3/4	11.3	25	12	8	6	4	3	5.7	15	14	14	10	10	10
	1	15.6	30	10	8	4	3	3	7.8	15	14	14	10	8	8
	1-1/2	17.7	40	10	6	4	2	2	8.8	20	12	12	10	8	8
2	1/2	18.8	40	10	6	4	3	1	9.4	20	12	12	10	8	6
	3/4	22.6	45	8	6	3	2	1/0	11.4	25	12	12	10	8	6
	1	31.2	60	6	4	2	1/0	2/0	15.6	35	12	10	8	6	4
	1-1/2	35.4	70	6	4	1	1/0	2/0	17.6	40	12	10	8	4	4
4	1/2								18.8	40	12	10	6	4	4
	3/4								22.8	50	10	8	6	4	3
	1								31.2	70	8	8	4	3	2
	1-1/2								35.2	80	8	6	4	3	1
	2								41.6	90	6	4	3	2	1

TABLE 9: Wiring Connections for 120 and 240 Single Phase Circuits for TEC Remote Controls

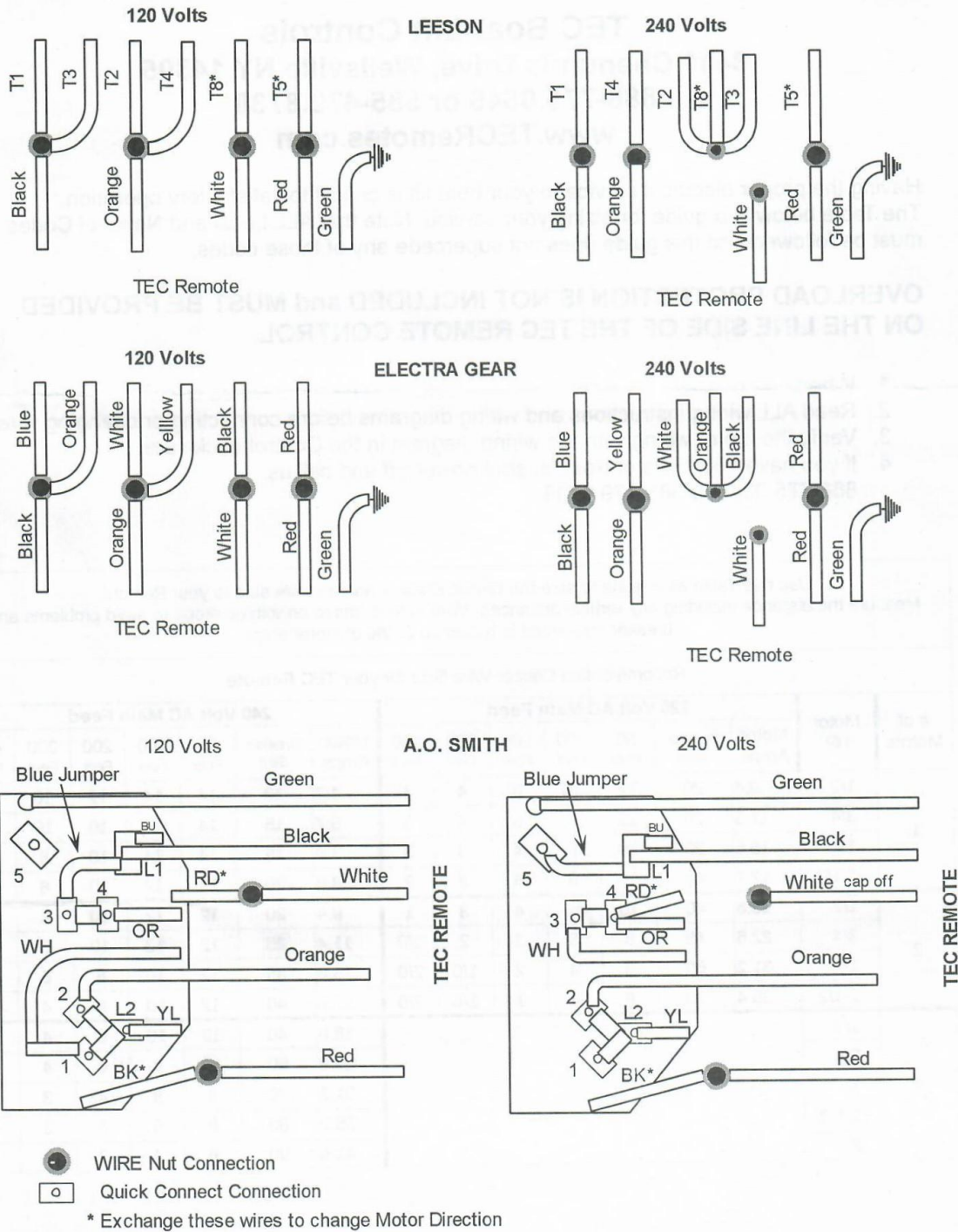
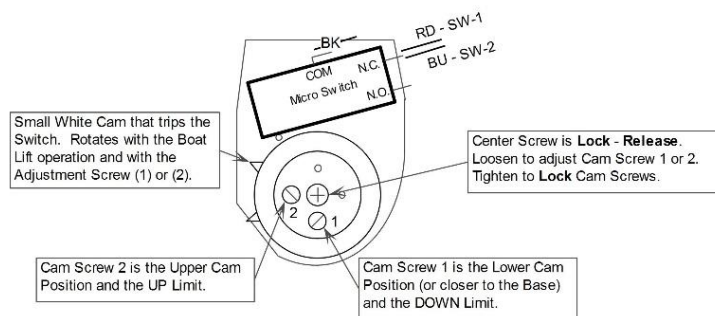

TABLE 10: TEC Remotes Auto-Control Limit Switch Set-up

Rotary Limit Switch Adjustment



Tools required: Phillips Head screwdriver, Small Slotted Head Screwdriver,
For this procedure "Remote" is used to identify the TEC Boat Lift Remote Control Box. Transmitter is the handheld control key-fob. **Turn OFF Auto Control switch** if so equipped.

Use the Manual Up-Down switch on the side of the Remote enclosure.

This procedure may best be performed with an assistant.

1. Remove limit switch cover by loosening the two screws.
2. Press Up manual Toggle switch on the enclosure and observe the direction that the two cams turn.

When your lift is at the maximum desired height release the button.

If the lift did not go as high as you need before stopping follow steps 3 and 4 to achieve this height.

Call the TEC Remote Factory for additional assistance.

Adjustment Procedures:

3. Your lift should be at the maximum desired height.
Loosen center lock screw shown in the picture below $\frac{3}{4}$ turn.
4. Adjust the upper limit using screw 2 (blue wire).
Adjust the screw so the cam hits the micro switch roller arm in the direction that the cam was turning so the leading edge of the cam trips the switch.
You will hear a small click (microswitch). If the roller arm is already on the cam, back it away and move the lift then readjust.
5. Press the Up toggle switch on the enclosure.
The lift should not turn on. **Re-tighten center lock screw!!**
6. Now press the Down toggle switch on the enclosure.
Watch the cams to see that they travel away from the roller switch arm.
If the down switch trips and the unit will not lower, loosen center lock screw and adjust the lower cam away from the roller switch arm, tighten the Lock screw, and continue.
7. When the lift is at the lowest point to be able to launch your boat at a low tide, or before the lift hits bottom, or it has a minimum of 3 wraps of cable on the drive pipe, adjust the bottom cam screw 2 until you hear a click.
Try pressing the down switch. **The lift should not turn on.**
8. **Re-tighten the Center Lock screw before you activate the lift.**
9. Turn on the Auto Control switch, if so equipped.
Operate the lift now with the Transmitter.
The lift should now run continuously by pressing a direction once on the Transmitter.
Run the lift up a foot then press the stop button, and the lift should stop.
Press down button (There is a 3 second delay when changing direction) and make sure the lift stops at the lower limit, if not readjust the limit and test again.
Check the up limit to ensure proper operation.
Check that the lift stops in both directions.
10. **FAILURE to follow these directions voids all warranties to equipment as written or implied. TEC will not assume any responsibility for damages that are a result of improper installation or user error.**
11. **WARNING:** Failure to tighten the Center Lock screw might not allow the cams to move correctly, therefore the **LIFT MAY NOT STOP**.
This could possibly cause damage to the limit switch, boat lift, boat, and/or the entire system.
12. **For maximum safety, we recommend that the TEC unit be turned off at the power source when not in use.**

APPENDIX D: PACKING LIST

NOTE: The lift is shipped with all the necessary hardware required for installation and operation. The installer will provide the piling mounting bolts (8 required) and electrical hardware as required by the electrician.

Table 2: Standard Equipment Shipped From the Factory

DESCRIPTION	QUANTITY
Top Cradle Beams (fully assembled)	2
Lower Cradle Beams with spanner pipes	2
Stainless Steel (SS) Cables 5/16 inch	4
Guide Stanchions, PVC and U-bolts or Backing Plates	4
Bunking System; Full Length Boards or Chocks	2 or 4
Electrical Switches	2
Parts Box/ Stainless Steel Bolts/ Nuts	Various
Owner's Manual	1

APPENDIX E: MOTOR INSTALLATION

- 1.) Mark location of original motor. Remove original motor and install new motor on base. Tighten mounting bolts.
- 2.) With belt on motor pulley, and 80% on gearbox pulley; Roll the belt the rest of the way onto gear box pulley.

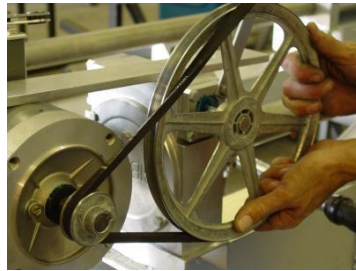

- 3.) **Test belt tension**. Applying moderate pressure on belt it should not deflect.
- 4.) If belt tension needs to be adjusted. Remove belt. Slide motor back ¼". Reinstall **belt** (repeat steps 1-3).
- 5.) **Align pulleys** with straight edge. To adjust pulley alignment, motor pulley can be adjusted in or out.

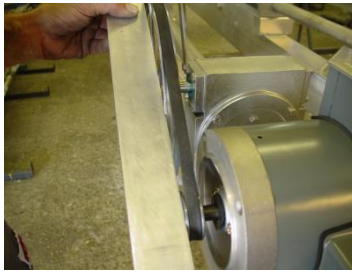

- 6.) Remove motor pulley set screw. **Apply Loctite** in hole.



- 7.) Reinstall set screw and tighten.