

UNDERGROUND STORAGE TANK CLOSURE GUIDANCE



Iowa Department of Natural Resources
Underground Storage Tank Section
502 East 9th Street
Des Moines, IA 50319-0034
(515-725-8200)
www.iowadnr.gov/ust

May 11, 2016

TABLE OF CONTENTS

UNDERGROUND STORAGE TANK (UST) AND PIPING CLOSURE CHECKLIST	1
STEP 1 - Notification of Intended UST Closure Activity	1
STEP 2—Preparatory Activities	1
STEP 3 - Oral Confirmation of Closure Date	1
STEP 4—UST Closure Activities.....	2
STEP 5—Closure Report.....	3
Environmental Services Division Field Office Map	4
Introduction	5
References	5
SECTION I: Health and Safety Considerations.....	6
Barricades	7
Fire Extinguishers	7
Fire Extinguisher Ratings	8
Multi-Class Ratings	8
Types of Fire Extinguishers	9
How to Use a Fire Extinguisher	9
Flash Point and Fire Point.....	10
Examples of Flash Points.....	10
Classification of Flammable and Combustible Liquids	10
Classification of Flammable Liquids (NFPA 30).....	11
Classification of Combustible Liquids (NFPA 30)	11
The Fire Triangle/Tetrahedron.....	11
Health and Safety Plan	11
Confined Space	12
Regulatory Requirements	13
SECTION II: Pre-Tank Removal Procedures	15
Iowa One Call	15
Underground Utility Markings.....	16
Electrical Safety.....	16
Drainage of Product.....	16
Excavating	17
Purging and Inerting	17
Purging	18
Inerting.....	18
Lower and Upper Explosive Limits.....	19
Purging: Monitoring Vapor Levels	20
Purging: Using a Diffused Air Blower	21
Purging: Using an Eductor-Type Air Mover	22
Inerting	23
Inerting: Monitoring Oxygen Levels	24
SECTION III: Removing the Tank From the Excavation.....	25
Removing Sludge and Cleaning the Tank.....	26
Labeling the Tank	26
Disposing of Waste Materials.....	28
Transporting the tank.....	28
Storing Used Tanks	30
Reusing Tanks.....	30
Piping	31

SECTION IV: Sampling for Contamination at Tank Removal	32
Visual Inspection	32
Soil Sampling Equipment.....	32
Release Reporting.....	35
Soil Sampling for Tank Closure (Removal)	35
Tank Bed Sampling When Bedrock is Present	38
Tank Bed Sampling with Bedrock Present, Multiple Tanks	39
Tank Bed Sampling with Concrete Pad Present	40
Tank Bed Sampling with Multiple Tanks and Concrete Pad	42
When Groundwater Interferes with Soil Sampling	44
Soil Sampling for Product Piping Closure	45
Exposed or Open Trench and Removal of Piping (Single Wall)	47
Closed Trench and Abandonment of Piping (Single Wall).....	47
Piping Run Sampling.....	48
Exposed or Open Trench and Removal of Piping (Double Wall)	48
Closed Trench and Abandonment of Piping (Double Wall).....	48
Soil Sampling Beneath the Dispenser (With and Without Containment)	49
Groundwater Sampling Requirements	50
Groundwater Sampling Equipment	50
Procedure for Groundwater Sampling	51
Laboratory Procedures for Testing Soil and Groundwater Samples.....	51
Contaminant Corrective Action Levels.....	52
Groundwater Sampling Requirements.....	53
Soil Sampling Locations Summary—Water Encountered	57
Soil Sample Locations Summary for Filling in Place, or When a Concrete Pad Interferes with Sampling beneath the UST	58
Sampling Exceptions	58
Backfill.....	59
Tank Fill in Place.....	60
Closure Report Forms	61
APPENDIX A: Qualifications for Excluding Groundwater Samples for UST Closures	73
Conditions for Exclusion	73
Definition of Highly Permeable Soils	73
APPENDIX B: Encountering Bedrock during Groundwater Sampling for Tank Closure	74
Certified Well Driller and Groundwater Professional Required	74
Shallow Bedrock Assessment	74
Field Screening for Contamination.....	74
When Bedrock Contamination is Suspected	74
Contamination in the Overburden with a Confining Unit	75
No Contamination in the Overburden.....	75
USTs Set in Bedrock	75
Summary	75
Plugging Abandoned Wells.....	75
APPENDIX C: Exempt Pre 1974 Tanks	76
APPENDIX D: Monitoring Records Used in Lieu of Soil & Water Sampling	77
APPENDIX E: Explosive Limits of Gases.....	78
Explosive Limits of Gases	78
APPENDIX F: Reporting Petroleum Releases from UST Systems	79



How removal used to be conducted. The tank is perilously suspended by this track-mounted crane. The operator is on the other side of the fence. Let's just say everyone involved is very lucky to have walked away unharmed.

STEPS TO SUCCESSFUL UST CLOSURE UNDERGROUND STORAGE TANK (UST) AND PIPING CLOSURE CHECKLIST

STEP 1 - Notification of Intended UST Closure Activity

- ✓ Send DNR Form 542-1308 "Notification of Closure/Change-in-Service" to the UST Section of the DNR 30 days before the tank closure is scheduled to take place. The form must be filled out completely, accurately and signed by the owner or Responsible Party. **NOTE: It is imperative that you check with your local fire authority for any local requirements (permits, site inspections during excavation, etc.) prior to removal.**

STEP 2—Preparatory Activities

- ✓ Confirm the availability of those contractors you may be using on the anticipated closure date (tank removers, tank cleaners, excavators, certified groundwater professionals). UST permanent closure must be conducted by an Iowa licensed remover. Notify DNR of any changes to the date of closure for your UST system.
- ✓ You must be a Certified Groundwater Professional in order to conduct or supervise closure sampling. Notify the Iowa Certified Lab of your choice of the types of samples you will need, and request the necessary sample containers. Testing for petroleum products shall be conducted by Iowa Methods OA-1 and OA-2 (if there have been low volatile fuels stored). Copies of these methods are available from the DNR.
- ✓ Obtain the necessary sampling equipment and packing materials to store the samples at approximately 40 degrees Fahrenheit after collection and during shipment. Samples must be received by the laboratory within 72 hours of collection.
- ✓ Make the Iowa One Call to have underground utilities identified and flagged. Iowa's One Call law requires at least 48-hour advance notice prior to any underground excavation (800-292-8989). This service is free and staffed 24 hours a day, seven days a week.

STEP 3 - Oral Confirmation of Closure Date

- ✓ Contact (telephone) the DNR field office at least 24 hours prior to actual closure to confirm the removal date. This phone call must be made weekdays between the hours of 8:00 a.m. and 4:30 p.m. See field office locations and phone numbers on page 4.

STEP 4—UST Closure Activities

Sampling Procedures and Tank Removal are explained in greater detail on the following pages.

- ✓ Drain and flush piping into the tank, and disconnect piping from the tank. Remove product piping.
- ✓ Empty the tank and purge all combustible vapors by inerting or venting through the vent line.
- ✓ Monitor the tank for combustibility with a combustible gas meter until the tank atmosphere is less than 10% of the lower flammable or explosive limit LFL/LEL.
- ✓ Remove tank appurtenances (gauge pipes, fill pipes, turbines, etc.) Leave vent line connected until the tank is purged.
- ✓ Plug the openings and remove the tank from the excavation. Place it on a level surface and block it, or fill the tank to 100 percent capacity with an inert material.
- ✓ Clean and remove the tank according to:
 - a. API RP 1604, Removal and Disposal of Used Underground Petroleum Storage Tanks,
 - b. API Publication 2015, Cleaning Petroleum Storage Tanks;
 - c. API RP 1631, Interior Lining of Underground Storage Tanks,
 - d. The National Institute for Occupational Safety and Health (NIOSH) *Criteria for a Recommended Standard...Working in Confined Space* may be used as a guidance for conducting safe closure procedures at some hazardous substance tanks.
 - e. NFPA 326: Standard for the Safeguarding of Tanks and Containers for Entry, Cleaning, or Repair
 - f. NFPA 30: Flammable and Combustible Liquids Code, 30-93.
- ✓ An Iowa Certified Groundwater Professional must supervise the collection of soil and groundwater samples, and send them to a certified lab for analysis within 72 hours of collection.

If contamination is discovered during soil or groundwater sampling, you must contact the DNR and report the contamination. To report a release, phone 515-725-8200 or fax to 515-725-8202. Forms for reporting a release are found on the UST Section website.

STEP 5—Closure Report

- ✓ Within 45 days of the tank or piping removal, submit a copy of the DNR's closure report form and the tank registration tags to the DNR. A copy of all reports and drawings must be maintained by the owner/operator for at least three (3) years.
- ✓ Written confirmation of receipt of the closure report will be mailed to the owner after all these items have been received and reviewed by the department.

Photo below: 12000 gallon double wall Xerxes fiberglass tank removed in May 2014 at QuikTrip, 6th and University Avenue, Des Moines.



Address all correspondence and questions to:

IOWA DEPARTMENT OF NATURAL RESOURCES
UNDERGROUND STORAGE TANK SECTION
502 E 9TH ST
DES MOINES IA 50319-0034
Phone: 515-725-8200

There are six (6) DNR Field Offices that oversee UST permanent closures throughout Iowa. Phone the field office in the region where the UST closure will occur at least 24 hours in advance to inform them of the date of closure. This phone call must be made weekdays between the hours of 8:00 a.m. and 4:30 p.m.

Iowa Department of Natural Resources Environmental Services Division Field Office Map

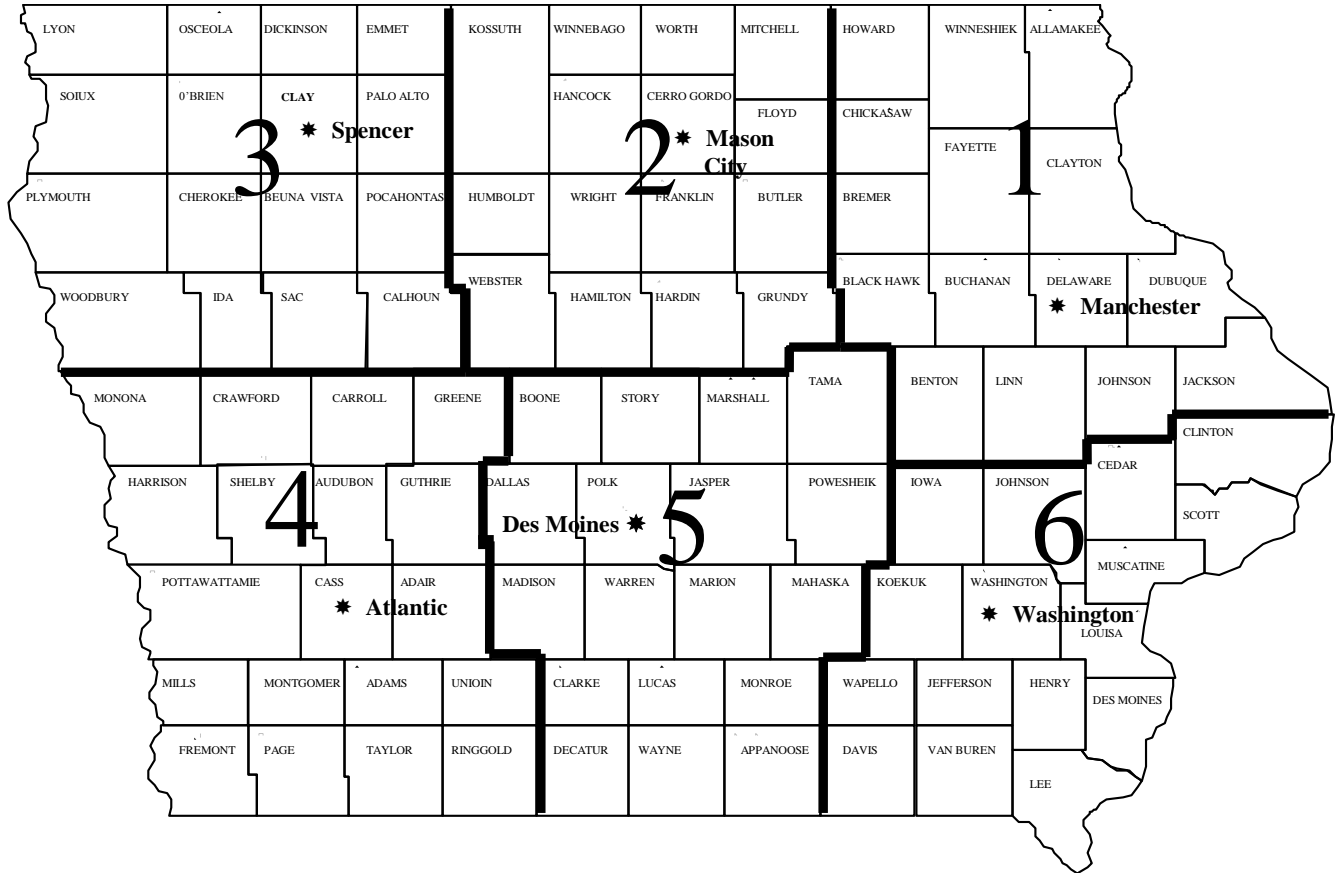

Field Office 1: Manchester, IA 52057
909 W Main, Suite 4
(563-927-2640)

Field Office 4: Atlantic, IA 50022
1401 Sunnyside Ln
(712-243-1934)

Field Office 2: Mason City, IA 50401
2300 15th St SW
(641-424-4073)

Field Office 5: Windsor Heights, IA 50324
7900 Hickman Rd Ste 200
(515-725-0268)

Field Office 3: Spencer, IA 51301
1900 N Grand Ave Ste E17
(712-262-4177)

Field Office 6: Washington, IA 52353
1004 W Madison
(319-653-2135)

IOWA DEPARTMENT OF NATURAL RESOURCES

UNDERGROUND STORAGE TANK (UST) SYSTEM CLOSURE GUIDANCE DOCUMENT

Introduction

- The purpose of this guidebook is to encourage safe UST removal. When regulated USTs are no longer needed they must be properly closed to avoid future safety and environmental hazards. Because these tanks contained flammable or combustible or hazardous liquids, UST removers must exercise the highest safety standards and practices. Accidents at UST removal sites are almost always avoidable. Safe work practices and an awareness of the potential hazards at the UST site will keep workers, the public, and the environment safe. This is merely a guidance document, and should be used for instructional purposes only. This document is not intended to be an in-depth explanation of the rules governing UST systems. You must also follow all the applicable Iowa rules and reference documents.

References

The following publications are referenced in Chapter 567--135 IAC “Technical Standards and Corrective Action Requirements for Owners and Operators of Underground Storage Tanks” or have been cited in this document and should be used as guides for further assistance in the permanent closure process.

- API RP 1604 (1996 or 2001) Removal and Disposal of Used Underground Petroleum Storage Tanks
- API Publication 2015, Cleaning Petroleum Storage Tanks
- API RP 1631, Interior Lining of Underground Storage Tanks
- API RP 2219, Safe Operation of Vacuum Trucks in Petroleum Service, 3rd Edition, November 2005
- The National Institute for Occupational Safety and Health (NIOSH) *Criteria for a Recommended Standard... Working in confined Space* may be used as a guidance for conducting safe closure procedures at some hazardous substance tanks
- NFPA 326: Standard for the Safeguarding of Tanks and Containers for Entry, Cleaning, or Repair
- NFPA 30: Flammable and Combustible Liquids Code, 30-93
- Occupational Safety and Health Administration (OSHA)—has rules that you must be familiar with. In one way or another, UST removal will be covered by OSHA. Under certain circumstances, OSHA Standard 1910.120 applies. This is the Hazardous Waste Operations and Emergency Response (HAZWOPER) standard of 29 CFR
- *Tank Closure Without Tears*, New England Interstate Water Pollution Control Commission, 85 Merrimac Street, Boston, Massachusetts 02114, May 1988

SECTION I: Health and Safety Considerations

Inhaling high concentrations of petroleum vapors can have effects that range from dizziness to unconsciousness.

High occupational exposures to benzene have been associated with various human blood disorders, including an increased risk of leukemia. Very high levels have also been known to affect the central nervous system. Benzene is rapidly absorbed through the skin.¹

Benzene and tetraethyl lead are known cancer-causing agents. Although lead has not been used in gasoline since the mid-80s, lead residues may still be present in older tanks and in the soil around the tanks. To minimize exposure to hazardous substances:

- Avoid skin contact and inhaling the vapors.
- Keep petroleum liquids and hazardous substances away from your eyes, skin and mouth.
- Use soap and water or waterless hand cleaner to remove any petroleum product that comes in contact with your skin. Do not use gasoline or other solvents to remove oil and grease from your hands.
- Promptly wash petroleum-soaked clothing and properly dispose of rags.
- Keep work areas clean and well ventilated.
- Clean up spills promptly.

Flammable and/or combustible vapors will be present in the work area. These vapors could reach the explosive range before venting is complete and a safe atmosphere is reached. Make these precautions part of your daily routine during UST projects:

- Eliminate all potential sources of ignition from the area. Some examples of ignition sources at an UST site are smoking materials, non-explosion-proof tools, hot surfaces, static electricity, electrical equipment, and internal combustion equipment.
- Prevent a discharge of static electricity during venting of USTs. Be sure that all equipment used during venting is grounded. It is good practice to ground to the tank and to the earth.
- Prevent vapors from accumulating at ground level. Keep all tanks vented at least 12 feet above ground surface until ready to remove them from the excavation. Also, check weather conditions before beginning a project. Humid weather and calm winds can be especially dangerous.

Gasoline vapors are heavier than air and will tend to stay close to the ground surface unless other forces, such as wind, are helping to disperse them. This is especially critical during tank removals on a calm day. You should consider using construction-size portable fans to help disperse vapors on these days.

Plan ahead. Visit the site before removal takes place. Leave yourself enough room to work safely. Look at the whole site, and determine where and how each activity will take place. Are there overhead obstructions, such as power lines, utility poles or a canopy? Make sure all underground utilities are located before excavating takes place.

¹ Closure of Underground Petroleum Storage Tanks, API Recommended Practice 1604, 3rd Edition, March 1996, Reaffirmed, November 2001. Page 1.3.1.1

Will any nearby buildings interfere with the excavation? The same formula for installing an UST near a building foundation applies to the removal excavation:

- Maintain a minimum distance of 5 feet from the edge of the excavation to the bottom of the building foundation.
- Then, the 45 degree line should strike the lower quadrant of the tank

Lay out the project on paper:

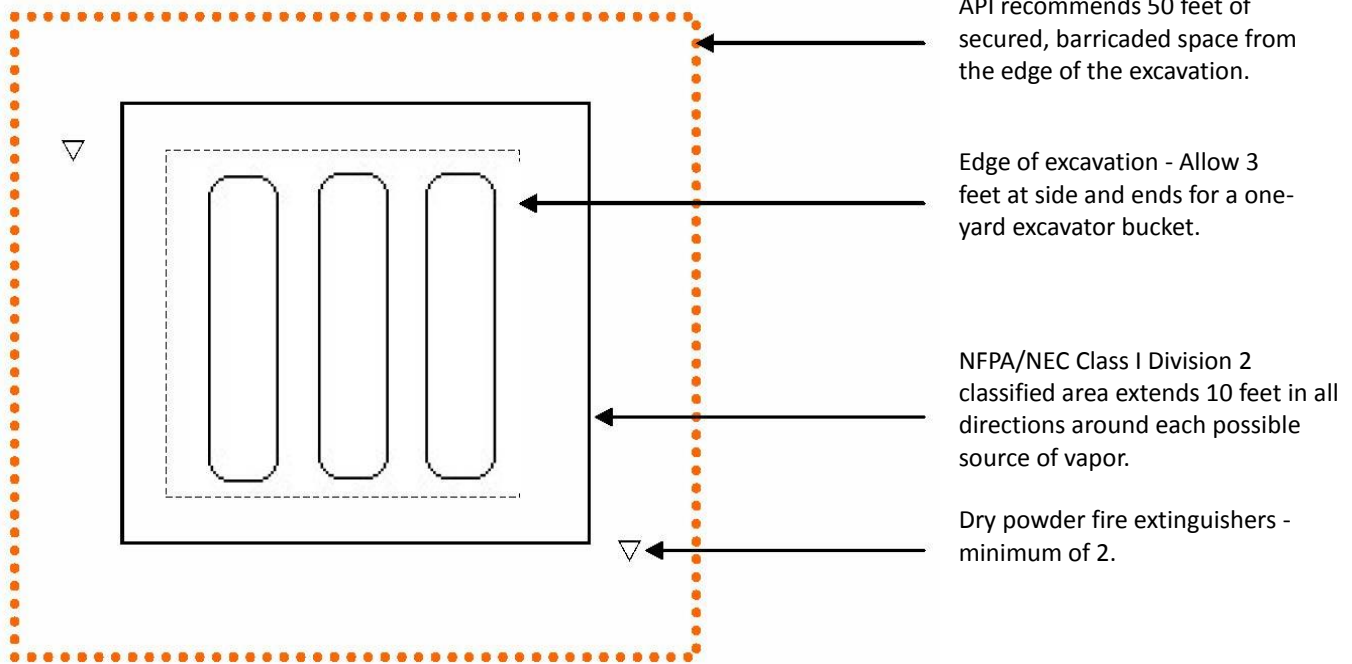

Barricades

- Erect and maintain barricades. Barricade as large an area as possible; API recommends 50 feet in all directions. Brightly colored barricade mesh fencing may be more expensive, but it is more effective. A-frames must be spaced close together to be effective in restricting passersby.
- Tank removals often take place at busy locations, including those open for business. Arrange your barricades so customers see where they are supposed to go, as well as where they are not supposed to go.

Fire Extinguishers

- Fire extinguishers are your first priority at all UST removals. Class B dry chemical extinguishers should be used on gasoline fires. The numerical rating of a fire extinguisher states the approximate number of square feet of a flammable liquid fire a non-expert person can expect to extinguish. A 40B extinguisher should extinguish 40 square feet of a flammable liquid fire. The Fire Marshal Division recommends a minimum of two 40BC fire extinguishers. Locate them at opposite corners of the project so they can be reached quickly. Check them every day to be sure they have not been tampered with, and are fully charged. Train your personnel in their proper use.

Fire Extinguisher Ratings



Class A Extinguishers will put out fires in ordinary combustibles, such as wood and paper. The numerical rating for this class of fire extinguisher refers to the amount of water the fire extinguisher holds and the amount of fire it will extinguish.



Class B Extinguishers should be used on fires involving flammable liquids, such as grease, gasoline, oil, etc. The numerical rating for this class of fire extinguisher states the approximate number of square feet of a flammable liquid fire that a non-expert person can expect to extinguish.



Class C Extinguishers are suitable for use on electrically energized fires. This class of fire extinguishers does not have a numerical rating. The presence of the letter "C" indicates that the extinguishing agent is non-conductive.



Class D Extinguishers are designed for use on flammable metals and are often specific for the type of metal in question. There is no picture designator for Class D extinguishers. These extinguishers generally have no rating nor are they given a multi-purpose rating for use on other types of fires.



Multi-Class Ratings



Many extinguishers available today can be used on different types of fires and will be labeled with more than one designator, e.g. A-B, B-C, or A-B-C. Make sure that if you have a multi-purpose extinguisher it is properly labeled.

This is the old style of labeling indicating suitability for use on Class A, B, and C fires.

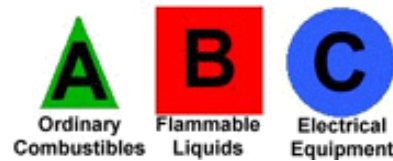

This is the new style of labeling that shows this extinguisher may be used on Ordinary Combustibles, Flammable Liquids, or Electrical Equipment fires. This is the new labeling style with a diagonal red line drawn through the picture to indicate what type of fire this extinguisher is **NOT** suitable for. In this example, the fire extinguisher could be used on Ordinary Combustibles and Flammable Liquids fires, but not for Electrical Equipment fires.

Types of Fire Extinguishers



Dry Chemical extinguishers are usually rated for multiple purpose use. They contain an extinguishing agent and use a compressed, non-flammable gas as a propellant.



Halon extinguishers contain a gas that interrupts the chemical reaction that takes place when fuels burn. These types of extinguishers are often used to protect valuable electrical equipment since they leave no residue to clean up. Halon extinguishers have a limited range, usually 4 to 6 feet. The initial application of Halon should be made at the base of the fire, even after the flames have been extinguished.



Water These extinguishers contain water and compressed gas and should only be used on Class A (ordinary combustibles) fires.



Carbon Dioxide (CO₂) extinguishers are most effective on Class B and C (liquids and electrical) fires. Since the gas disperses quickly, these extinguishers are only effective from 3 to 8 feet. The carbon dioxide is stored as a compressed liquid in the extinguisher; as it expands, it cools the surrounding air. The cooling will often cause ice to form around the "horn" where the gas is expelled from the extinguisher. Since the fire could re-ignite, continue to apply the agent even after the fire appears to be out.²

How to Use a Fire Extinguisher

Even though extinguishers come in a number of shapes and sizes, they all operate in a similar manner. Here's an easy acronym for fire extinguisher use:

P A S S -- **P**ull, **A**im, **S**queeze, and **S**weep



Pull the pin at the top of the extinguisher that keeps the handle from being accidentally pressed.



Aim the nozzle toward the base of the fire.



Stand approximately 8 feet away from the fire and **squeeze** the handle to discharge the extinguisher. If you release the handle, the discharge will stop.

Sweep the nozzle back and forth at the base of the fire. After the fire appears to be out, watch it carefully since it may re-ignite!



Success!

² Information provided from the Hanford Fire Department, operated by Fluor Hanford, Inc. for the US Department of Energy, Richland Operations Office, Document Number: INTERNET-1053.

Flash Point and Fire Point

The **flash point** is the lowest temperature at which a liquid gives off vapor to form an ignitable mixture with the air, near the surface of the liquid.³ At this temperature the vapor may cease to burn (flash) when the source of ignition is removed. The **fire point** is a slightly higher temperature at which the vapor continues to burn after being ignited.⁴ A liquid that has a flash point at or below ambient temperature is easy to ignite and will burn quickly, e.g., gasoline. A low flash point can indicate highly volatile material and presents a greater risk of fire.

A liquid with a flash point above ambient temperature is more difficult to ignite and presents less risk because it does not give off sufficient vapors, e.g., home heating oil or Fuel Oil No. 2.⁵ Liquids with flash points above ambient temperature have to be heated to generate enough vapor to be ignitable.

The **fire point** of a liquid is the temperature at which ignition of vapors will result in continued burning.⁶ The fire point is used to assess the risk of a materials ability to support combustion or continue to burn. Both values affect how the material or liquids may be shipped, stored and discarded.⁷

For our purposes, the flash point is a useful characteristic of liquid fuel, indicating at which temperature it will ignite or burn when a source of ignition is applied (flame, spark). The flash point helps us appreciate and understand the risks involved and the safety measures required in working around flammable/combustible liquids.

The US Department of Transportation requires that all substances transported have a flash point determined and that any materials with flash points lower than 60 degrees C (140 °F) be handled with extra caution.

Examples of Flash Points

Fuel	Flash Point
Ethanol	55 °F (12.8 °C)
Gasoline	-40 °F (<-40 °C)
Diesel (1-D, 2-D and 4-D)	143 °F (>62 °C)
Jet Fuel	100 °F (>38 °C)
Kerosene (paraffin oil)	100–162 °F (>38–72 °C)
Vegetable Oil (canola)	3620 °F (27 °C) ^[1]
Biodiesel	266 °F (>130 °C)

Classification of Flammable and Combustible Liquids

The classification of liquids is based on flash points. A flammable liquid is any liquid that has a flash point below 100 °F (37.8 °C). Flammable liquids are classified as Class I with sub-classifications (see table below).

³ NFPA, 2008 Flammable and Combustible Liquids Handbook, 4.2.4.

⁴ See 49 CFR-Chapter 1-Part 173.120. See also NFPA 30, 1.7.2.2.

⁵ See Flammable and Combustible Liquids Code Handbook (NFPA 30 and 30A) 2008 Edition, 4.2.4.

⁶ NFPA 30 Flammable and Combustible Liquids Code Handbook, 2008 Edition, A.4.2.4.

⁷ Northern Technology & Testing Website, <http://www.nttworldwide.com/tech2212.htm>.

Flammable liquids, in other words, ignite easily and burn rapidly. A combustible liquid is any liquid that has a flash point at or above 100 °F.⁸ Combustible liquids are classified as Class II or Class III.

Classification of Flammable Liquids (NFPA 30)⁹

Classification	Flash Point	Example
Class I Liquid	Below 100 °F (37.8 °C)	
Class IA	Below 73 °F (22.8 °C) and boiling points below 100 °F (37.8 °C)	Ethanol, Pentane
Class IB	Below 73 °F and boiling points above 100 °F (37.8 °C)	Gasoline, Isopropyl alcohol, Ethyl alcohol, Acetone, Toluene, Benzene
Class IC	73-100 °F	Turpentine, Xylene, Styrene, Butyl alcohol, Diethyl glycol

Classification of Combustible Liquids (NFPA 30)¹⁰

Classification	Flash Point	Example
Class II	101-140 °F	Kerosene, Diesel fuels, Pine tar, Stoddard solvent, Jet fuel, Fuel Oil 1, 2, 4 and 5
Class IIIA	141-199 °F	Fuel Oil No. 1
Class IIIB	200°F or above	Fuel Oil No. 6, Ethylene Glycol, Motor Oil

The Fire Triangle/Tetrahedron

Four ingredients must exist at the same time in order to produce a fire:

- 1) Enough Oxygen to sustain combustion,
- 2) Enough heat to raise the material to its ignition temperature (ignition source),
- 3) A combustible material (petroleum), and
- 4) The chemical reaction that is fire.

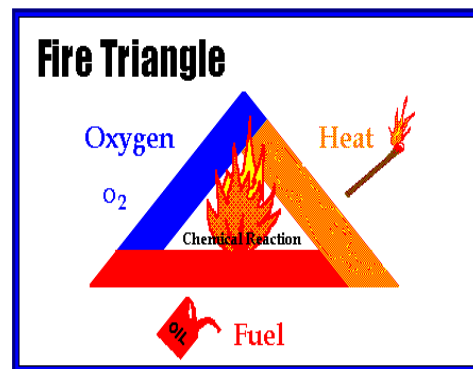

The *Fire Triangle* might more appropriately be called the *Fire Tetrahedron*. Add in the fourth ingredient, chemical reaction, and you have a fire tetrahedron. The important thing to remember is remove any one of these ingredients, and you will not have a fire or the fire will be extinguished. For example, fire extinguishers put out fire by removing one or more ingredients of a fire triangle or tetrahedron.

Health and Safety Plan

- Prepare a site-specific Health and Safety Plan (HASP), and keep it onsite. The HASP must address the safety and health hazards of each phase of the project. The HASP must provide for pre-entry briefings

⁸ NFPA 30, See 3.3.30.1 and 3.3.30.2 also 4.2.2 and 4.2.3.

⁹ Ibid. 3.3.30.1

¹⁰ Ibid.

before beginning any site activity, and at any other time it becomes necessary to keep employees aware of conditions. The plan must designate a site safety and health supervisor, and the safety supervisor must have the authority to shut the project down if personnel health or safety is jeopardized. The plan should also include a communications system, which can be hand signals if they are clearly understood. An emergency communications system, such as sounding a motor vehicle horn an established number of times, must be clearly understood. The HASP should be evaluated at least daily, and must be updated if changing conditions warrant.

- Employees must be advised of the chemical, physical and toxicological properties of each substance that is known or expected to be present on the site.
- Entering the excavation should not be an option. Besides the added cost of sloping and shoring, employees would be put at risk. Consider an approach that does not require your employees to enter the excavation.

Excavations are one of the most hazardous activities in the construction industry. The primary accident at an excavation site is cave-in. According to OSHA statistics, someone is usually killed in a cave-in. Excavations do not have to be deep, such as a tank pit, to be dangerous. Workers have been killed in trench cave-ins; you do not have to be buried to be killed. Trench cave-ins often result in massive lung and liver injuries; you can be crushed to death.

The OSHA Standard 29 CFR 1926.650-652 requires that employees in an excavation be protected from cave-ins. There are four sloping options available:

- 1) Slope the excavation at an angle not steeper than 1½ feet horizontal to 1 foot vertical—expressed as 1-½:1. See 1926.650-652, Subpart P, Appendix B.
- 2) Slope the excavation in accordance with the OSHA simplified soil classification system, which ranks soils according to the stability. See 1926.650-652, Subpart P, Appendices A and B.
- 3) Use a design created and sealed by a registered professional engineer *in the state of the excavation*.
- 4) Use a site-specific design sealed by a registered professional engineer *in the state of the excavation*.

An excavation that will be entered can be sloped ½:1 (½ foot horizontal to 1 foot vertical) if it meets these criteria:

- 1) The excavation is in Type A soil (the most stable soil type after rock);
- 2) The excavation will not be open more than 24 hours; and
- 3) The excavation is no deeper than 20 feet.

Even in stable soils, however, if the excavation will be open longer than 24 hours, the sides must be sloped at least ¾:1.

Confined Space

Not only is it more expensive to slope or shore an excavation than to plan your removal project so no one has to enter the tank pit, you are putting your employees into a Confined Space situation. OSHA requires specific training for employees who must work in a Confined Space situation. Plan the UST closure so that no employees have to enter the excavation.

A Confined Space is a space with limited ventilation, the potential to accumulate or contain a hazardous atmosphere, exits that are not readily accessible, and not meant for continuous human occupancy. This includes excavations and trenches. There are many hazards associated with working in a Confined Space. Among them: ladder tip-over, buried utilities, falling equipment or material, and unplanned rescues. Instinctively rushing in to help someone who has become trapped in a Confined Space too often makes an already bad situation worse. Citing OSHA statistics again, half of all workers who die in Confined Space accidents are trying to rescue others.

Working in a Confined Space requires training; performing a rescue from a Confined Space takes more training. If employees absolutely must work in an excavation, train them in safety and self-rescue. Comply with all of the OSHA rules for Confined Space entry and activity; it is someone's life.

You must provide ladders, ramps or other safe means of exit in all trenches that are 4 feet deep or more. The means of exit must be within 25 lateral feet of workers. An earthen ramp can only be used if a worker can walk it in an upright position, and only if a competent person has evaluated it.

Regulatory Requirements

- An Iowa licensed tank remover must be on site during removal to conduct the closure process.
- Soil and groundwater sampling are required for all UST permanent closure and must be conducted or supervised by an Iowa Certified Groundwater Professional (CGWP). Make sure you have a CGWP scheduled to conduct sampling.
- At least 30 days before the tank removal, a Notification of Closure form must be completed and submitted to the department.
- Determine what receptors exist in the area of the tank removal. Is the site an active LUST site? Are there active groundwater monitoring wells on site? Will any of the wells interfere with UST permanent closure? Talk to the LUST project manager to discuss options.
- This is also the time to notify the fire prevention bureau of the local fire department and to begin the permitting process through all the local authorities.



Above: A Des Moines May 2014 tank removal of three 12000 gallon fiberglass tanks.

Below: Some careful excavating was required in order to spare the driveway to a next door residence.



SECTION II: Pre-Tank Removal Procedures

Because of the nature of the flammable or combustible liquids that are stored in USTs, hazardous conditions are likely to exist in the tank removal area. All personnel involved in the closure operation should be familiar with the potential hazards and be aware of the appropriate health and safety measures needed to ensure a safe working environment.

During inerting, purging, and removal procedures, all necessary precautions to prevent ignition in the area must be taken, including but not limited to: grounding and bonding of equipment, using explosion-proof or intrinsically safe equipment, monitoring for vapors in the surrounding area, and controlling pedestrian and traffic flow.

Keep the following in mind when planning a storage system closure:

- It is imperative that you check with your local fire authority for any local requirements (permits, site inspections during excavation, etc.) prior to removal.
- Go out to the site and conduct an inspection of the area where you will be working. Determine what equipment you will need, and obstacles that you will need to remove or work around. Are there wells in the area such as private drinking water wells, public water wells, or groundwater monitoring wells that may require special attention with regard to evaluating the site for contamination or special precautions with regard to spillage of product?
- Review American Petroleum Institute (API) Publication 1604 *Closure of Underground Petroleum Storage Tanks*, the New England Interstate Water Pollution Control Commission (NEIWPCC) CD and booklet, *Tank Closure Without Tears*, NFPA 326 Standard for the Safeguarding of Tanks and Containers for Entry, Cleaning or Repair, and NFPA 30 & 30 A Flammable and combustible Liquids Code Handbook which complement this guidance document and will help you accomplish a safe tank removal. OSHA has prepared an excavation guidance manual which you should also be familiar with. OSHA's website is www.osha.gov.
- Tank removal operations are likely to generate significant quantities of flammable vapors. Evaluate weather and ambient atmospheric conditions such as wind velocity, wind direction, and humidity prior to beginning the tank removal operation to ensure that vapors will be adequately dissipated.
- Understand and abide by all safety precautions. They are good for you and the environment.

Iowa One Call

- Contact **Iowa One Call**. The toll free number is 800-292-8989. The Iowa One Call center is open 24/7 365 days a year. When you call, be ready to provide detailed location information, including the name of the property owner, the specific location of the excavation (9-1-1 address), and directions to the site. It is best not to call anytime on Mondays and between the hours of 7 a.m. and 11 a.m. on other weekdays as these are the busiest times at the call center. Ask for a "Joint Locate" where you meet the Iowa One Call locator on site. This is the best way to get accurate answers to your questions about subsurface utilities.

- OSHA requires that you determine the location of any underground utilities that reasonably may be expected to be encountered before you open the excavation. See OSHA Standard 29 CFR 1926.651(b)(1) and (b)(2).
- Local and state laws require that you determine the exact location of a utility before you excavate. Remember that utility locators only have to mark within three (3) feet on either side of a utility to have done their job. It is your responsibility to ensure that utilities are not damaged.

The same state law that requires utility owners to register their utilities and you, the contractor, to notify before excavating, also requires the following colors be used to identify the utility locations.

Underground Utility Markings

Operator and Type of Product:	Identifying Color
Electric Power Lines, Cables, Conduit and Lighting Cables	Red
Gas, Oil, Steam, Petroleum or Gaseous Materials	Yellow
Communication, Alarm or Signal Lines, Cables or Conduit	Orange
Water, Irrigation and Slurry Lines	Blue
Sewers and Drain Lines	Green
Temporary Survey Markings	Pink
Proposed Excavation	White
Reclaimed Water	Purple

Electrical Safety

Disconnect all electrical service going into, under, or through the UST area. Turning off wall switches is not enough. You must use circuit breakers to de-energize the circuits. Use lockout/tag out procedures to ensure that power is not accidentally restored. Use your voltmeter or voltage sensor to confirm that electrical circuits are de-energized; don't take chances. Electrical work, including de-energizing circuits, may need to be done by a licensed electrician. Check with local authorities to determine who can perform electrical work.

Drainage of Product

Drain product piping back into the tank. If the piping system is pressurized, you will have to remove or open fully the STP check valve and open the shear valve test ports at each dispenser island to drain the piping. If the system is suction and has a check valve at the tank-top, you will need to excavate to the tank top and remove the check valve to drain the piping. Keep in mind when actually removing the piping that some product may remain in the piping. Take precautions not to spill any remaining product.

Pour enough water/cleaner solution into the piping at each dispenser island to ensure a triple rinse of the piping volume. Pump or vacuum the solution out of the tank. You can also use nitrogen (in place of a triple rinse) to flush fuel out of the product piping. Nitrogen is more expensive, but generates less waste that will have to be properly disposed of. The flow rate of the nitrogen must be high enough to flush as much fuel as possible into the tank. Be sure the tank is appropriately vented so that vapors will dissipate and the pressure in the tank remains below 5 psi. Avoid spilling fuel in the excavation area.

Remove all liquids and residue from the tank. Use explosion-proof or air-operated pumps or a vacuum truck. If you rinse the tank with water, you will be able to remove more of the residue. You may have to use a hand pump to remove the last few inches of liquid from the tank bottom.

Be careful while pumping, especially when using a vacuum truck on a gasoline tank. Fresh air will enter the underground tank and may bring the atmosphere inside the tank into the flammable range. Bond and ground all pump motors and suction hoses to prevent a buildup of static electricity.

If you use a vacuum truck, the area around the truck must be kept as vapor-free as possible. Locate the truck upwind of the tank. The suction hose must be grounded. The vacuum pump exhaust gases must be vented through a line of adequate size. The exhaust vent of the vacuum truck should be located downwind of the truck and tank area and be at least 12 feet above the ground surface.

Excavating

Remove the concrete/asphalt surface over the tank. It is a good idea to separate this material from the backfill material that may need special handling due to contamination. Select your on-site storage area for excavated materials carefully so it will not interfere with subsequent activities. All excavated material must be kept at least two (2) feet from the edge of the excavation, or it must be secured to keep it from falling into the tank pit or causing a cave-in.

Excavate to the top of the tank and remove all tank-top equipment. This includes the fill pipe and drop tube unless you will be using an eductor to purge the tank. Remove all tank risers and product piping and conduit that are accessible and uncovered. Do NOT disconnect the vent line.

The vent line must remain connected until the tank is purged. Plug all other tank openings as you remove the tank top equipment and risers. This will keep vapors in the tank and out of the work area.

The objective at this stage of the project is to access and remove everything possible while the excavation is still shallow. This will avoid having personnel work in, over, or around a deeper, potentially more dangerous excavation at later stages of the tank removal.

Contaminated backfill must be separated from clean backfill during excavation. This can be accomplished by visual observation and by field screening the material as it is excavated. Report obvious contamination to the department.

Purging and Inerting

Once a tank is empty of liquid fuel, the atmosphere inside the tank is a potentially explosive mix of fuel vapors and air. Keep all potential ignition sources a safe distance away. These include smoking materials, tools that can cause a spark, electrical equipment that is not explosion-proof, and internal combustion engines.

Whether you are purging or inerting, you are removing one of the ingredients in the fire triangle (either fuel or oxygen) in order to control the atmosphere inside the tank and avoid an explosion. Where possible, the safest way to avoid an explosion is to eliminate both the oxygen and fuel components of the fire triangle. You should ALWAYS minimize ignition sources when working around tanks.

Purging

Purging is the removal of flammable vapors from a tank either by drawing the vapors out using an eductor, or blowing the vapors out using a diffused air blower. Purging eliminates the fuel ingredient of the fire triangle. A combustible gas indicator (CGI), which is also called an explosimeter, is a device used to measure the concentration of combustible gases. A CGI will only operate properly in the presence of sufficient oxygen. Use an oxygen meter in conjunction with a CGI to monitor the progress of the purging operation. Remember that fuel vapors can regenerate inside the tank. Continue purging as long as possible and monitor the tank atmosphere often.

Inerting

Inerting is the removal or displacement of Oxygen from a tank using a non-reactive or inert gas. Dry ice (which is frozen carbon dioxide or CO_2) or Nitrogen (N_2) are the gases that are commonly used for inerting. Inerting eliminates the oxygen ingredient of the fire triangle. An oxygen meter is used to monitor the progress of the inerting process. Be sure to use an oxygen meter that will work properly in the presence of the gas you are using to inert the tank. Inerting is often the procedure of choice when tank removal takes place in a densely populated urban area because the volume of petroleum vapors generated by inerting is much less than the volume of vapors generated by purging.

Purging and inerting are very different procedures and have very different monitoring requirements. Whether you are purging, inerting, or both, be sure you understand exactly what you are doing. If conducting both purging and inerting procedures, be sure to do the purging first.

Safety concerns do not end once the tanks are purged or inerted. Tanks must be removed from the ground, loaded onto a truck, transported safely, and stored securely while they are waiting to be destroyed. Tanks can regenerate explosive vapors regardless of how well they are cleaned. A used tank will never be safe as long as it remains a tank.

Lower and Upper Explosive Limits

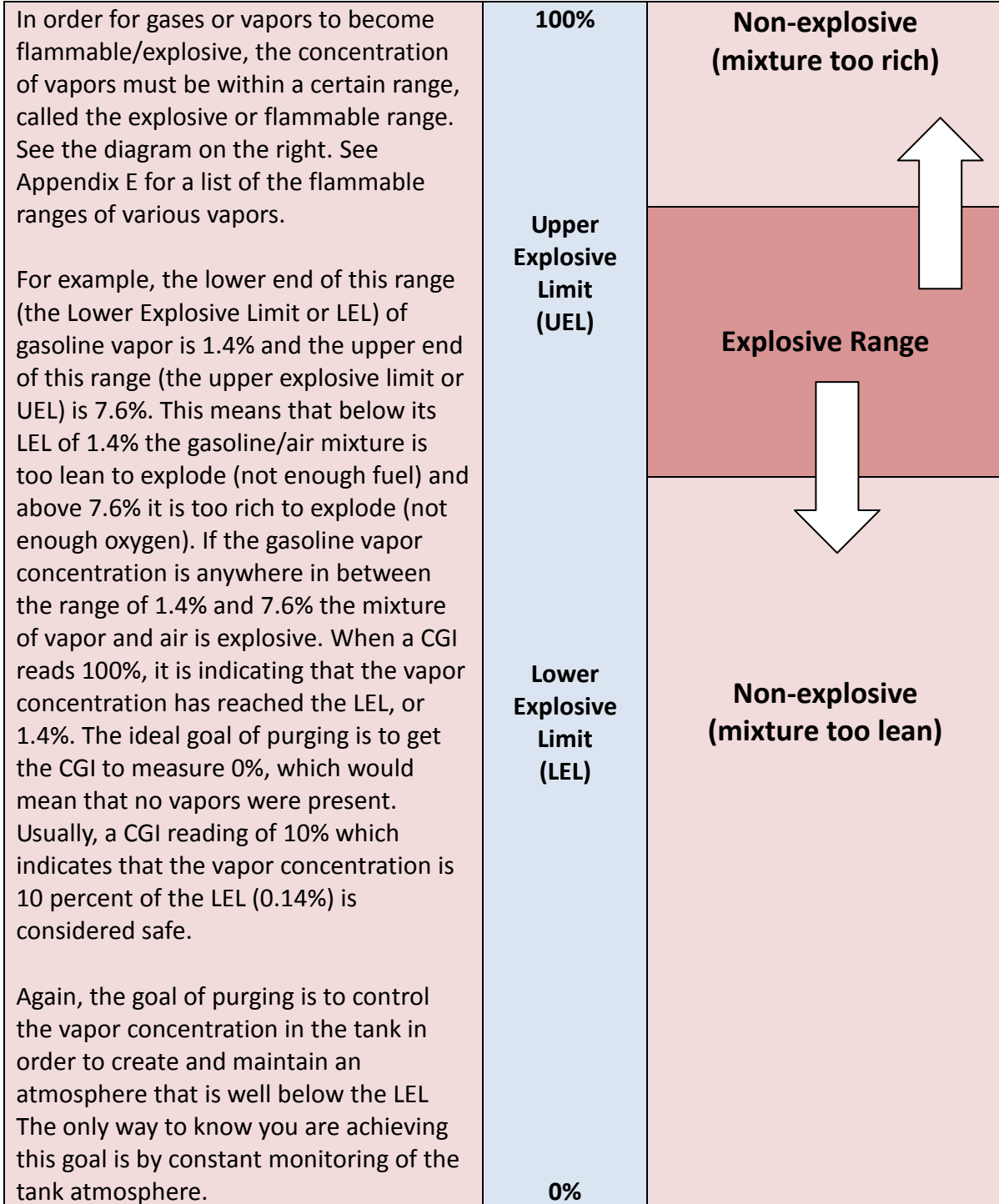

Purging: Monitoring Vapor Levels

When purging a tank, use a CGI to measure the vapor concentration inside the tank. Take readings from openings at both ends and the middle of the tank and from the bottom, middle, and the upper levels of the tank at each opening. All of these readings should be below 10% of the LEL. Most CGI's require normal levels of oxygen to operate properly. Use an oxygen meter to ensure that adequate levels of oxygen are present to allow the CGI to give correct readings.

For double wall tanks, check the interstice for vapors as well. If the primary wall was breached, there could be hazardous levels of vapors in the interstice.

Carefully follow the CGI manufacturer's instructions for calibration, operation, and maintenance of the instrument at all times. Your life depends on the measurements made by the CGI.

Continue monitoring the tank atmosphere until the tank has been loaded for transport and is ready to leave the site. The tank atmosphere must be safe when the tank leaves the site.

Caution! Keep the following in mind when purging a tank:

- Immediately before beginning work on the tank or in the tank area, check the vapor concentrations in the tank with a CGI.
- Gasoline vapors are heavier than air and may sink to low areas. Check vapor levels in low spots on the work site where vapors can accumulate.
- Even after purging, a tank can regenerate flammable vapors. Check vapor levels often.
- Purging causes large volumes of flammable vapors to be expelled from the tank. Vent all vapors at least 12 feet above grade and 3 feet above any adjacent roof lines.
- Keep the work area free of all sources of ignition.
- Ground and bond the tank and all equipment used for purging to prevent the buildup of static electricity.
- Be sure that personnel using monitoring equipment are thoroughly trained in the use of the instruments and how to interpret the readings.
- When introducing compressed air into a tank, make sure the tank is properly vented so that it does not over-pressurize.

Purging: Using a Diffused Air Blower

When using a diffused air blower, fresh air is circulated through the tank from an air compressor, forcing the explosive vapors out of the tank through the vent. The vent opening must be at least 12 feet above the ground. All other tank openings must be plugged. The drop tube and all other in tank equipment must be removed. The diffuser must be bonded to the tank and grounded to the earth. The flow of air into the tank must be controlled so that the pressure inside the tank never exceeds 5 psig. Always work with a dependable pressure gauge, and check it often during the purging process. Continue purging as long as possible up to the time the tank is removed from the excavation.

A Positive Pressure or Diffused Air Blower

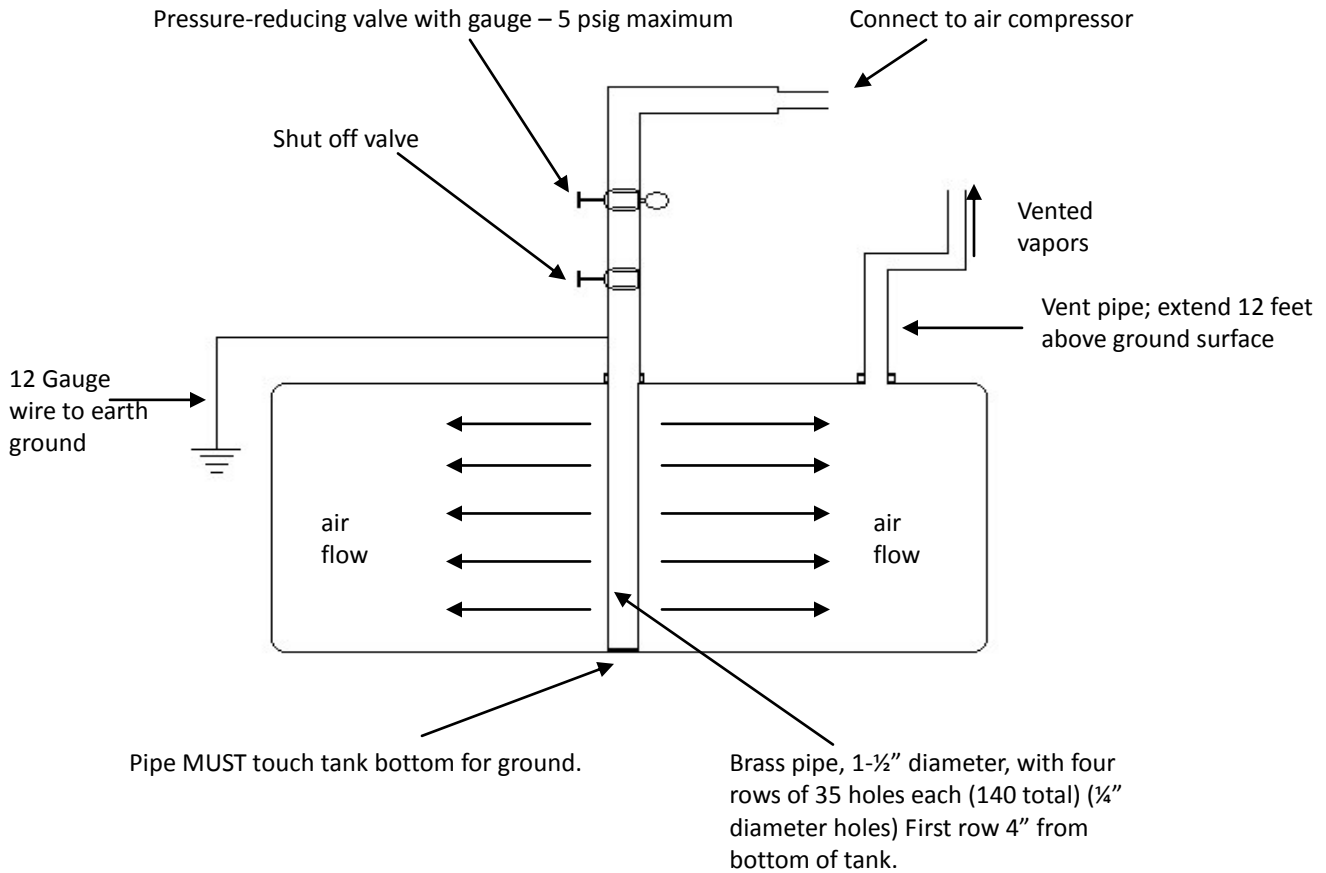

Purging: Using an Eductor-Type Air Mover

When using an eductor, air is pumped through the eductor from an air compressor. The venturi construction of the eductor draws additional air from the tank through the base of the eductor. The air from the compressor and the air/vapors from the tank are both discharged through the top of the eductor. Fresh air is drawn into the tank through the vent. The top of the eductor must be at least 12 feet above the ground surface. The eductor is attached to the fill pipe and the drop tube is left in place for this method so that vapors will be drawn from the bottom of the tank. All other tank openings except the vent must be plugged. The eductor should be bonded to the tank and grounded to the earth. Continue purging as long as possible up to the time the tank removed from the excavation.

At right: photo of eductor in operation at a Des Moines tank removal. Purging should continue as long as possible to keep vapors from regenerating in the tank.



Below: a diagram of an eductor-type air mover.

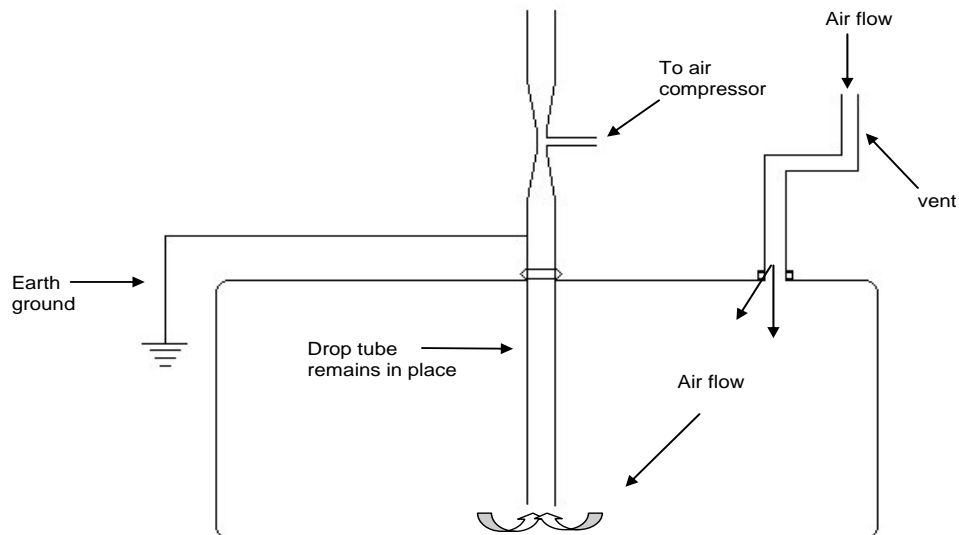

Inerting

Inerting addresses the oxygen component of the fire triangle by replacing the oxygen in the tank with a non-reactive gas. One of the most-widely used methods of inerting a tank is by adding dry ice, which is carbon dioxide in solid (frozen) form. Nitrogen gas is also commonly used to inert tanks. Inerting may be preferable to purging when removing tanks in densely populated urban areas because inerting generally releases a smaller volume of flammable vapors into the atmosphere than purging.

When using dry ice to inert a tank, the API and the NFPA recommend adding 1½ to 2 pounds of dry ice per 100 gallons of tank capacity. The dry ice should be shaved or crushed and distributed evenly over the greatest possible area of the tank's interior. Insert the dry ice through each available tank opening, resealing each tank opening as soon as the addition of the dry ice is completed. As the dry ice warms, it vaporizes and releases carbon dioxide gas, which is heavier than air and settles to the bottom of the tank. As the level of carbon dioxide gas increases, the vapors, oxygen, and air in the tank are pushed out of the tank vent. It generally takes longer to inert with dry ice than it does with nitrogen.

Caution: The temperature of dry ice is -109.3°F (-78.5°C). Skin contact with dry ice can cause severe damage to the skin.

Some tips on handling dry ice:

- Dry ice does not melt, it sublimates. Sublimation is the process of going directly from a solid to a gas. Dry ice bypasses the liquid state, giving it its name *dry ice*.
- Dry ice will sublimate at a rate of 10 pounds every 24 hours in a standard insulated container. Be sure to allow for loss of dry ice during transit to the work site.
- Plan to pick up your dry ice as close as possible to the time when you plan to use it. Avoid opening and closing the container as much as possible.
- If you remove only a portion of the dry ice from a container, fill the empty space with wadded newspaper. Dead air space will cause the dry ice to sublimate faster.
- Do not store dry ice in an airtight container. The accumulation of carbon dioxide gas can cause an airtight container to burst.

Nitrogen is introduced into a tank as compressed gas from cylinders. Cylinders of compressed carbon dioxide could also be used rather than dry ice. Because compressed gas cylinders contain gas under high pressure, controlling the pressure is very important when introducing the gas into a tank. Introduce compressed gases through a supply line near the bottom of the tank and at the opposite end from the vent. Use a low flow rate to minimize the generation of static electricity. Use bonding and grounding measures to minimize the accumulation of static charges.

Never discharge a CO₂ fire extinguisher into a tank. Static electricity produced by discharging a CO₂ fire extinguisher can ignite flammable vapors and cause an explosion.

A tank that has been inerted does not contain enough oxygen to support combustion. This means that there is also not enough oxygen to support life. Do not enter a tank that has been inerted!! Only tanks that have been properly purged can be entered! Always follow confined space entry procedures when entering a tank.

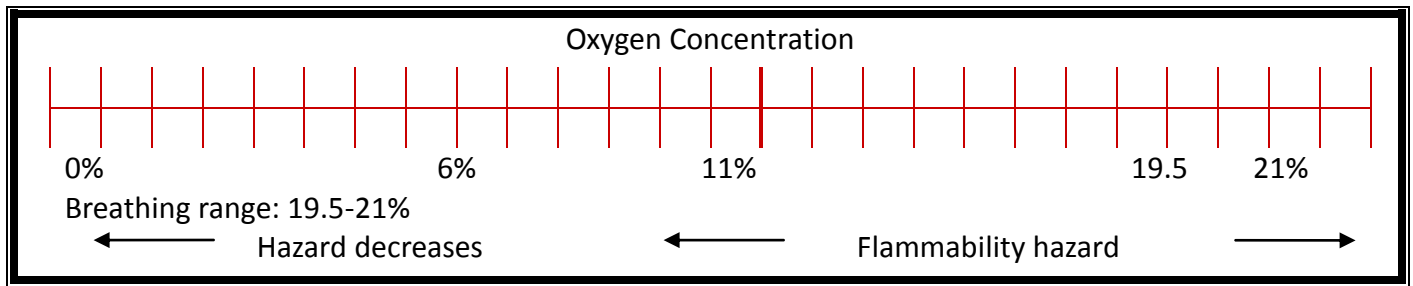

Inerting lowers the oxygen concentration in the tank to a level below which combustion will not occur. Combustion should not occur below 11%, but to play it safe make sure the oxygen is 6% or lower.

Inerting: Monitoring Oxygen Levels

Air is roughly 21% oxygen and 79% nitrogen by volume. The safe breathing range for oxygen is 19.5-21%. Most petroleum products need a minimum of 11.5-14% oxygen to support ignition or combustion. To provide a margin of safety, the oxygen concentration should be reduced to 50% of the lowest level of oxygen necessary to support combustion, or about 6-7% oxygen.

Use an oxygen meter to measure the oxygen level inside the tank. Take readings from openings at both ends and the middle of the tank and from the bottom, middle, and the upper levels of the tank at each opening. Do not take readings through a drop tube. All readings should indicate that the oxygen level is 6 percent or less. Continue monitoring the tank atmosphere until the tank has been loaded for transport and is ready to leave the site. The tank atmosphere must be safe when the tank leaves the site.

During inerting, flammable vapors will be exiting the tank vent. Monitor the excavation area and any other nearby low spots for the presence of flammable or combustible vapors using a CGI.

SECTION III: Removing the Tank From the Excavation

The tank is ready to be removed from the excavation only after it has been successfully purged or inerted

After the tank atmosphere has been made safe, but before removing the tank from the excavation, remove the vent pipe and install a plug or cap with a ¼" hole. This hole will prevent the tank from becoming over-pressurized due to temperature changes. The tank should always be positioned with this vent plug on top, including during subsequent transport and storage. All of the other tank openings should already have been plugged and should remain plugged.

If there are multiple tanks in an excavation, plan on removing one of the end tanks first and working your way across the excavation. Excavate around three sides of one tank to finish uncovering it and to prepare it for removal. See the diagram below.

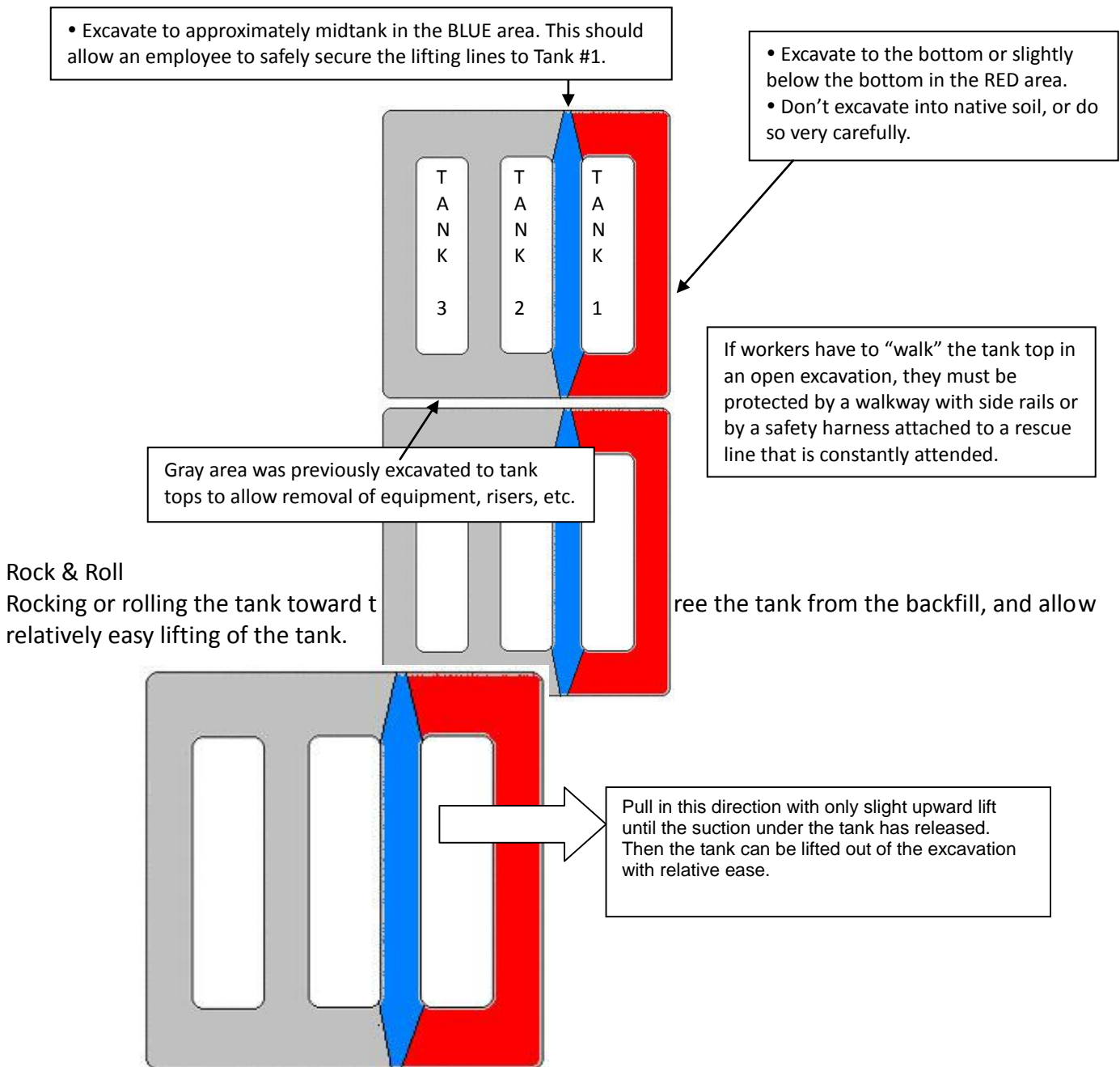

When removing the tank, remember that:

- All excavated material must be kept at least two (2) feet from the edge of the excavation, or it must be secured to keep it from falling into the hole or causing a cave-in.
- You must use equipment capable of safely lifting the tank. The tank should not be dragged.
- Place the tank on a level surface and block it to prevent it from rolling.

Removing Sludge and Cleaning the Tank

Iowa DNR regulations (567--64.3(1) IAC) prohibit the discharge of liquid waste into the environment. Contract with a licensed hazardous/non-hazardous waste transporter who can properly document on a hazardous/non-hazardous waste manifest the generator, transport and proper disposal/treatment of the hazardous/non-hazardous waste. A list of tank cleaners/vacuum services is provided at our website. Drumming petroleum contaminated liquid and sludge and leaving it on site is not proper disposal, nor is transporting it to a Publicly Owned Treatment Works (POTW). Always contract with a licensed hazardous/non-hazardous waste transporter.

If there is not sufficient room above grade at the site to safely clean the tank, it is possible to remove the sludge while the tank is still in the excavation. Tip the tank toward one end and then wash the sludge to the low end where it can be pumped out. When deciding whether to clean the tank in or out of the excavation, consider the space available to do the work, the ability to restrict sources of ignition from adjacent traffic and people passing by, the likelihood that flammable vapors may accumulate on site, and any other site specific factors that could endanger personnel working on the site or the general public. Check local requirements to see if there are restrictions on how or where cleaning activities can be conducted.

If the tank is to be entered to manually remove sludge from the bottom of the tank or scale buildup from the tank walls, be sure to follow all confined space entry requirements and continue to purge the tank. Removing the sludge from the tank and triple rinsing the inside of the tank will reduce the possibility of vapors regenerating.

After the tank has been cleaned, make sure you receive a signed certificate from the tank cleaning company certifying the cleanliness of the tank. Document the cleaning of tanks with photographs and include them with the closure report.

Labeling the Tank

Before transporting the tank from the site, it must be properly labeled. Lettering must be large and legible from a distance and include a warning against reuse of the tank. The API recommends that the following information be included in the label:

- TANK HAS CONTAINED _____ (gasoline, diesel, kerosene, etc., as appropriate)
- NOT VAPOR-FREE
- NOT SUITABLE FOR STORAGE OF FOOD OR LIQUIDS INTENDED FOR HUMAN OR ANIMAL CONSUMPTION
- MONTH/DAY/YEAR the tank was removed

If the tank has held leaded gasoline, or if the history of the tank is unknown, it should be clearly labeled with the following information:

- TANK HAS CONTAINED LEADED GASOLINE
- TOXIC LEAD VAPORS MAY BE RELEASED IF HEAT IS APPLIED TO THE TANK SHELL

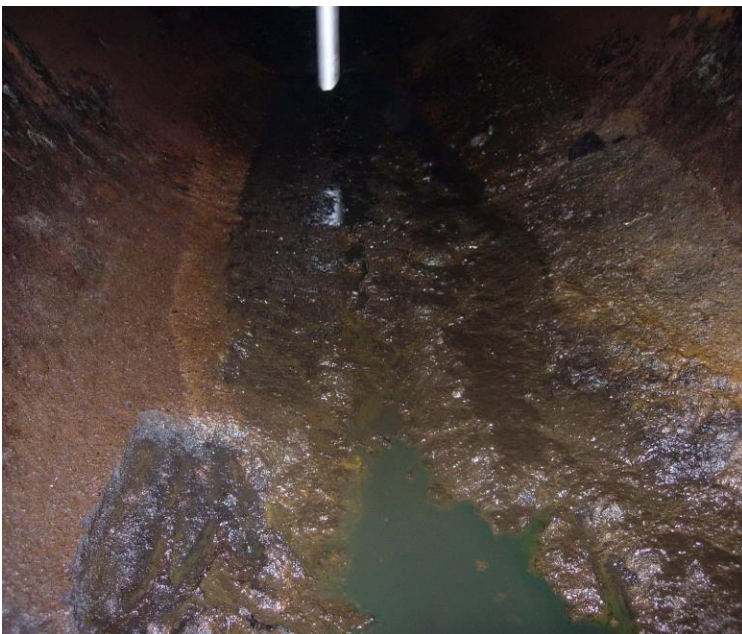

Entering a tank is a confined space procedure.

The atmosphere inside the tank (above) is being purged using an educator while the person is inside cleaning the tank.

A supplied air respirator is not used because the oxygen level is within the breathing range, however, an air purifying half mask is essential because toxic levels of vapors are likely to be present.

The photo at left shows the sludge the technician above is removing.

Disposing of Waste Materials

The licensed tank remover is responsible for proper disposal of all waste materials generated during the tank removal process. This includes, but is not limited to, excavated material, non-salvageable storage system components, the tank itself, any fuel or sludge in the tank, and the water used to clean the tank. Waste material must be transported and disposed of using transporters and disposal facilities which possess all required federal, state and local licenses or permits. Submit manifests certifying the proper transport, receipt, and disposal of waste materials with the closure report.

Transporting the tank

Keep the following in mind when preparing to transport the tank off site:

- The tank should be removed from the site as soon as possible after removal. Fiberglass tanks may be crushed on site. Check local requirements before destroying tanks on site.
- If a tank remains on-site overnight or longer, vapors may regenerate from residues remaining in the tank. Always monitor the tank atmosphere to be sure the tank is properly purged (below 10 percent LEL) or inerted (below 6 percent oxygen) immediately before the tank leaves the site.
- Plug any holes in the tank walls that would allow any residues to leak out during transport.
- Scrape off any chunks of dirt or clay that could fall from the tank during transport.
- Be sure the tank is properly secured before transporting, and that the 1/4-inch vent hole is located at the uppermost point on the tank.
- The transporter is subject to all local, state and federal transportation laws.



Photo above: Tank being secured for transport.



Top photo: Tank removal in Waukon. Planning a tank removal must take into account overhead power lines and canopies that can present risks for removers.

Bottom photo: a documented release. This is the same tank as above. Note the two quarter-size perforations.



The photo below shows a tank installed in the 1960s that was later internally lined. Boiler plugs were used to repair holes in the tank before it was lined. This photo provides documentation that a release likely occurred at this site before the tank was lined.

Accurately describing the condition of the tank in the closure report is important for determining whether contamination that is present may be due to a new or an old release.



Storing Used Tanks

If a tank is placed in storage, make sure it has been cleaned and residues removed to minimize the regeneration of vapors. Only the ¼-inch vent hole should be left open. Always store used tanks in a secure area where access is restricted to personnel who understand the hazards that are present.

Reusing Tanks

Removed tanks may not be reused for storing petroleum products or other regulated substances unless they are recertified by the manufacturer. Otherwise, removed tanks are not suitable for reuse for any purpose and therefore must be rendered unusable.

- If you transfer ownership of the tank to another party, such as a scrap iron dealer or salvage yard, prepare a Bill of Sale to officially transfer ownership of the tank. The Bill of Sale should include the purchaser's acknowledgement that the purchaser assumes all liability for the tank. The Bill of Sale should include warning language similar to the warning label applied to the tank:
- TANK HAS CONTAINED _____ (gasoline, diesel, kerosene, etc., as appropriate)
- NOT VAPOR-FREE
- NOT SUITABLE FOR STORAGE OF FOOD OR LIQUIDS INTENDED FOR HUMAN OR ANIMAL CONSUMPTION



Tanks must be rendered unfit for future use, not put up for sale. The owner of these tanks was told to remove them to a landfill or salvage yard. Tanks can regenerate vapors and are a hazard to public safety unless they are in a secure area

Piping

The tank removal procedure should include removal of all the associated piping. Use care when excavating the piping. It can be very useful if you can identify corrosion holes, defects, improper installation or loose fittings that may have contributed to contamination at the site. Dispose of the piping in the same manner as the tank.

SECTION IV: Sampling for Contamination at Tank Removal

Iowa *Technical Standards and Corrective Action Requirements for Owners and Operators of Underground Storage Tanks* [567—135.15(3)] govern soil and groundwater sampling requirements at tank removals. Proper soil and groundwater sampling procedures must be followed in order to obtain meaningful results. To ensure that sampling procedures are properly followed, tank owners and operators must contract with an Iowa Certified Groundwater Professional (CGWP) to conduct or supervise soil and groundwater sampling.

Visual Inspection

The purpose of an assessment at tank closure is to determine whether a release had occurred from any part of the UST system at any time during its active life. It is important for the tank remover and CGWP to investigate each storage system component for the presence of perforations, cracks, loose fittings or connections, or damage of any kind which may have caused a release.

During the removal process be alert for any evidence of a petroleum release including stained or petroleum saturated soils, strong petroleum odors, or a rainbow sheen on any water that might be present. These are all indicators that a petroleum release has occurred and must be reported to the Iowa DNR.

Samples must be discreet samples, that is, representative of the conditions at one location, such as in line with a spill bucket beneath a tank, and not composite samples. Samples should be collected promptly (during the removal procedures) and collected from freshly exposed native soil. There should be no reason to enter the tank pit to collect soil samples. This would require adherence to applicable OSHA regulations. Grab samples from a backhoe bucket are preferable to workers entering a tank pit.

If samples are to be collected by drilling, split spoon, hollow stem and continuous core are acceptable sampling devices. Grab samples from drill cuttings are not acceptable. Drilling and sample collection should be conducted in accordance with Tier 1 Guidance.

Soil Sampling Equipment

Consult with the Iowa certified lab of your choice for information on recommended sampling equipment and containers. In general, there are two basic types: a brass sampling tube with acetate liner and a glass jar with a Teflon septa lid.

If samples are to be collected by drilling, hollow stem, split spoon and continuous core are acceptable sampling devices (see Tier 1 Guidance). Direct push (DP) equipment with a continuous soil core may be used for soil sampling for closure. Core diameters vary depending on the size of the DP equipment used, but a soil core of at least one and one-eighth inch is preferred.

When hand-sampling or manual sampling, a soil sampling tube is a convenient way to collect a sample from the bottom of an excavation. A rigid acetate liner is inserted into the brass soil sampling tube and the tube is pushed at least two-thirds of the way into the soil. The sample can be collected directly from the bottom of the excavation (e.g., a shallow pipe trench that is safe to enter) or from a backhoe bucket of soil retrieved from the bottom of a tank excavation.

Use only clean jars obtained from the laboratory that will conduct the analyses. Always compact the soil into the container tightly and fill the container completely. No void spaces should be visible in the container. Secure the lid tightly. Use a container that is large enough so that the entire quantity of soil required for each sample can fit into a single container. Sample containers should be clearly labeled and promptly sealed and

placed on ice for transport to the Iowa Certified Lab. Do not allow samples to be held so that the maximum holding time of 72 hours is violated.

Use a site drawing to indicate the sample locations along with a verbal description of the sample. Label each sample container exactly as it is identified on the site drawing. The sample label should also indicate the facility name, tank owner, date, and the substance stored in the underground tank. Immediately place the samples in a cooler to maintain them at approximately 40 degrees Fahrenheit. Do not allow the samples to freeze.



Removers, excavators and CGPs must look for obvious signs of contamination. In these photos contamination is not from overfills, but from damaged, leaking spill buckets. This is why we sample beneath the tank in line with the spill bucket or fill port and STP sump.



The top photo shows a damaged spill bucket that obviously leaked into the backfill and around the tank. The photo on the left shows a piece of 2 inch Ameron pipe that was pressurized and soap tested after removal. This site was part of an autopsy study conducted by the South Dakota Petroleum Contamination Fund. There are several leak locations, one located where the elbow and pipe connect.

Release Reporting

When there is evidence indicating there has been a release to the environment, the storage system owner must notify the Iowa DNR within 24 hours of discovery under normal circumstances or within six hours if a hazardous condition exists. As the contractor doing the work, you will likely be the first one to identify a release. You must notify the tank owner as soon as you discover the evidence of a release so that the tank owner can meet this reporting requirement. To file a report, the owner should call 515-725-8200 Monday – Friday 8:00 AM - 4:30 PM or send a fax to 515-725-8202 ATTN: Underground Storage Tank Section.

In addition to the telephone report filed by the tank owner which must be received within 24 hours, UST professionals must report releases to the Iowa DNR within 7 days of discovery on a special form. This form is included as Appendix F in this guidance document and also available on the Iowa DNR website www.iowadnr.gov/ust.

When the contamination poses an immediate threat to life or health such as explosive conditions or contamination of public or private drinking water supplies report it immediately to the Iowa DNR's 24 Hour Environmental Emergency Response Hotline 515-725-8694. This is an environmental-related emergency phone number and is only to be used when an immediate threat to life or health is present. Upon receiving the report, department personnel will provide further direction.

Soil Sampling for Tank Closure (Removal)

At a minimum, soil sampling for UST closure must include sample analysis for benzene, toluene, ethylbenzene, and xylenes (OA-1) and OA-2 group chemicals, diesel and motor oil if applicable. Submit any field screening results and photos of the removed tanks and excavation with the closure report. Under no circumstances should one ever enter a tank pit to collect samples.

Follow these guidelines for taking the soil samples.

- Inspect the excavation (floor and sidewalls) for evidence of contamination provided the sidewalls are stable and water is not present in the tank bed. Collect samples from any areas where contamination is observed, from the most obvious and heavily contaminated soils to the least obvious, least contaminated. Figure 1 shows contamination near the fill port and suggested screening and/or sample locations. Screen for the highest reading and submit that sample for analysis. Sample at 12 inches minimum and a maximum depth of 24 inches.

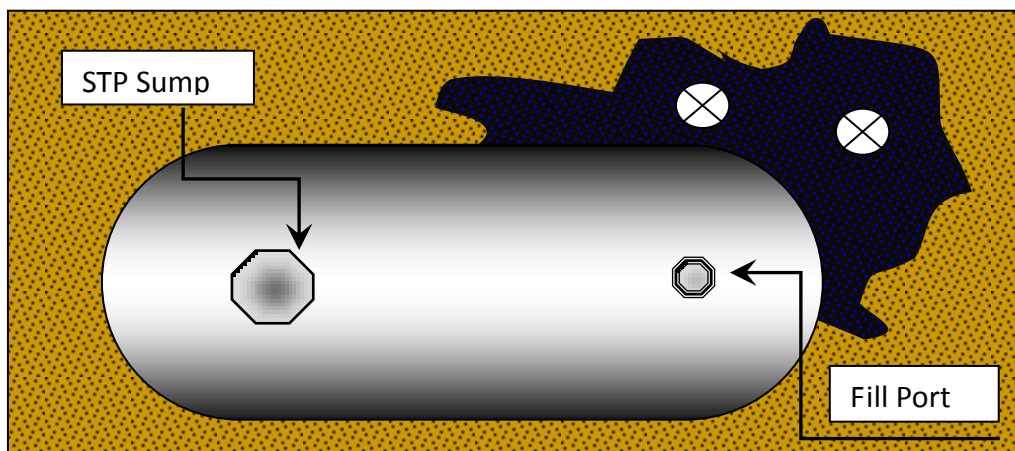

Figure 1

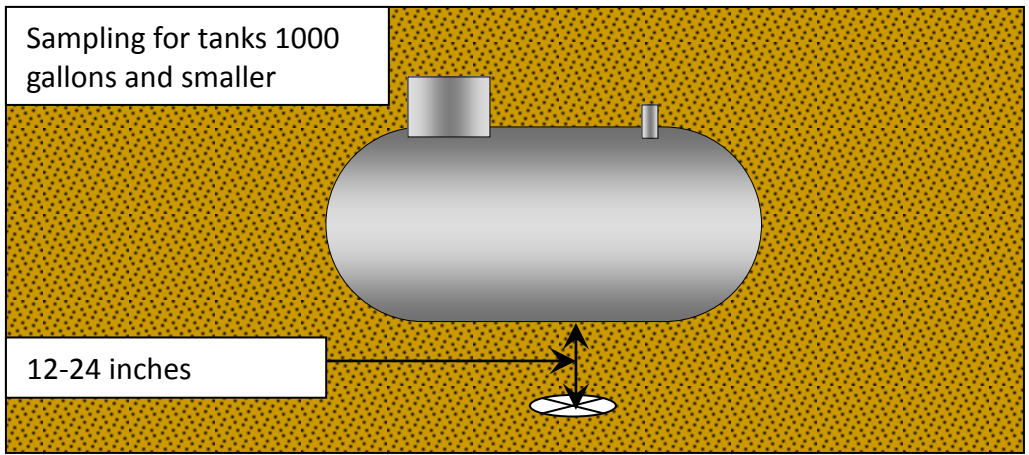

Figure 2

In addition to obvious contamination, collect the standard number of samples according to tank size. Figure 2 shows where to collect a sample for a tank 1000 gallons or smaller capacity. Collect the sample at a depth of one foot (minimum) to two feet (maximum) into native soil.

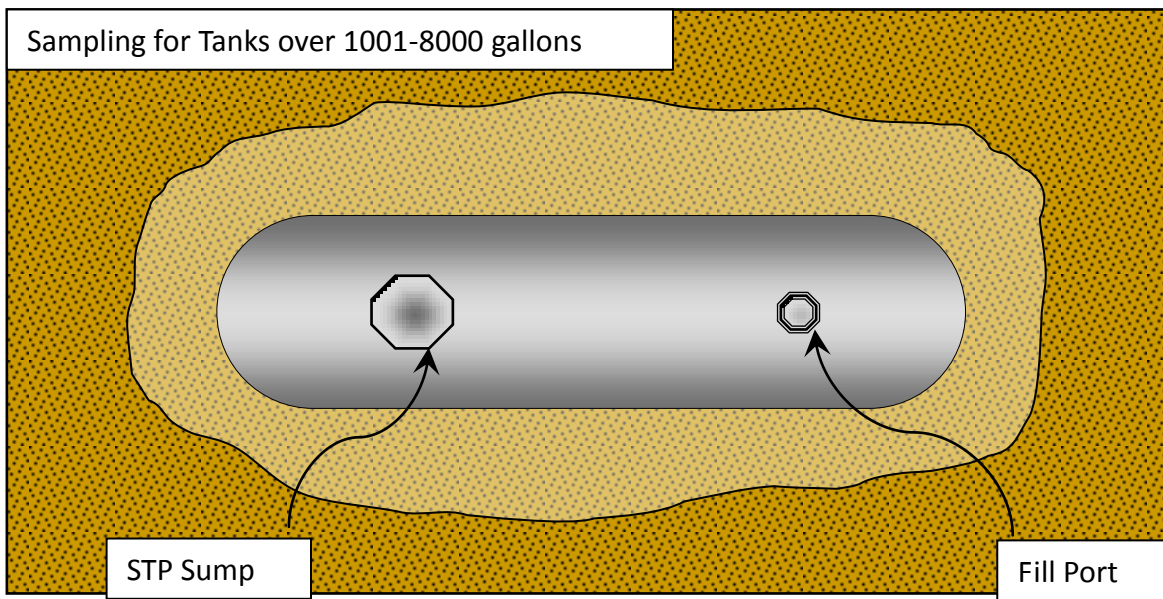

Figure 3

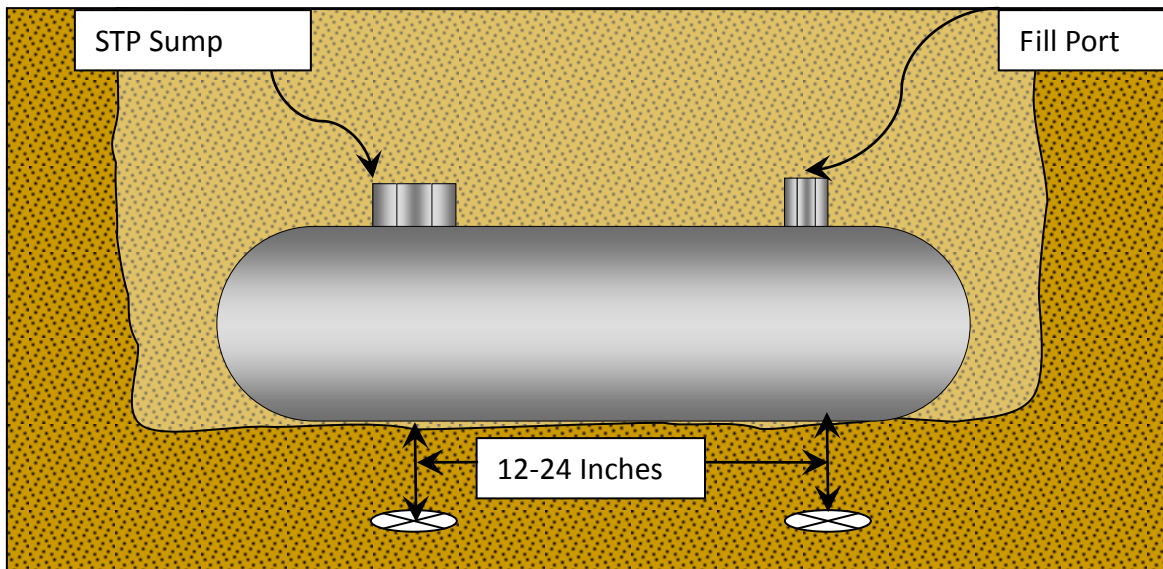

Figure 4

For tanks 1001 to 8000 gallons capacity (if evidence of contamination is not observed), collect two confirmatory samples from areas where leaks are most likely to occur and migrate—in line with the spill containment or fill port, and in line with the submersible turbine pump (STP) and piping connections. Collect samples one to two feet into native soil.

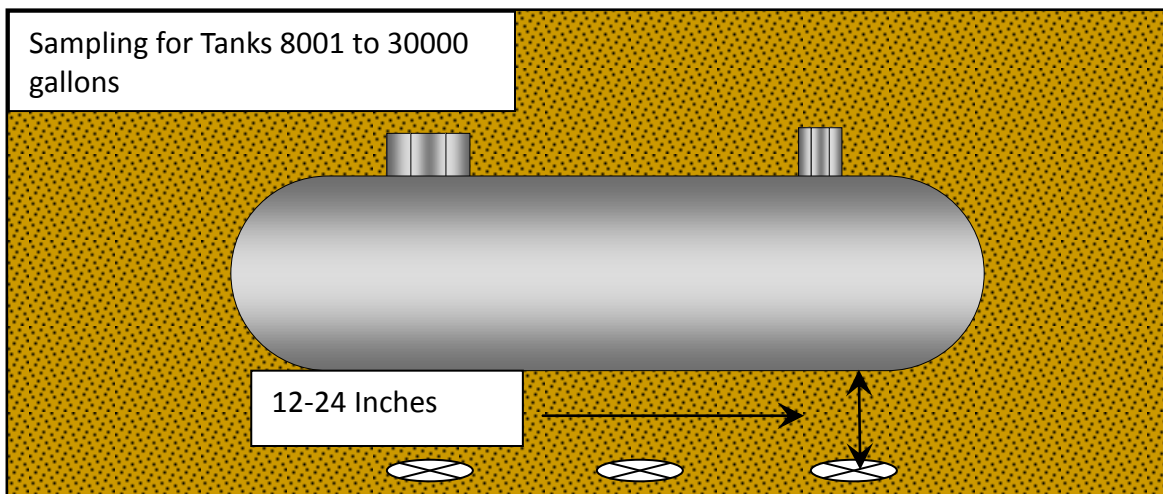

Figure 5

For tanks 8001 to 30000 gallons capacity (if evidence of contamination is not observed), collect two confirmatory samples in line with the spill containment or fill port, and in line with the STP and piping connections and a third sample in the middle of the tank. Collect samples one to two feet into native soil.

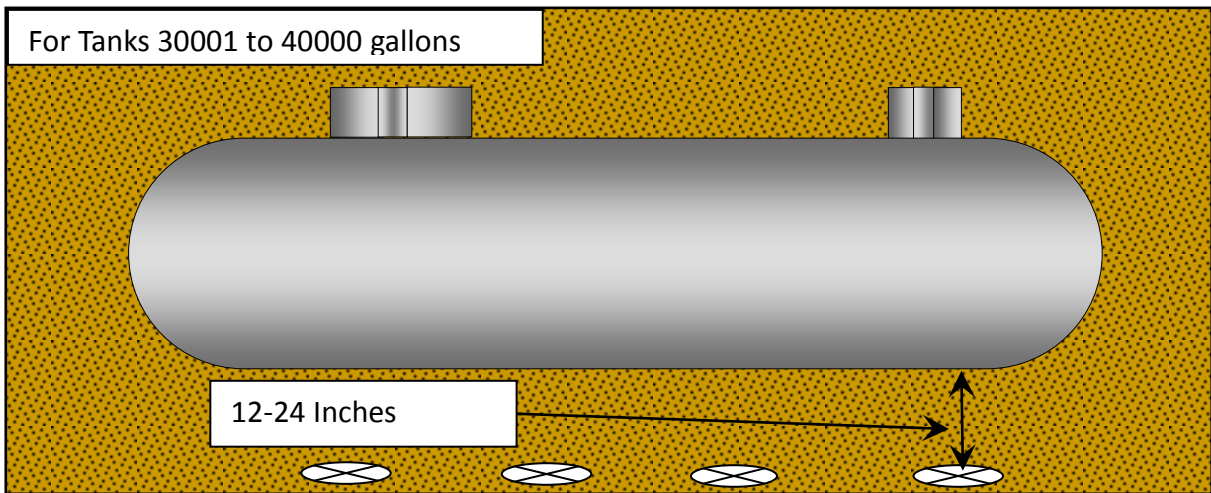

Figure 6

For tanks 30001 to 40000 gallons capacity (if evidence of contamination is not observed), collect confirmatory samples in line with the STP sump and spill containment or fill port and one sample 15 feet from each end for a total of four samples beneath the tank. Collect samples at a minimum depth of one foot into native soil.

For tanks 40001 or greater, collect samples in line with the STP sump and the spill containment, 15 feet from the ends and at center for a total of five samples.

Tank Bed Sampling When Bedrock is Present

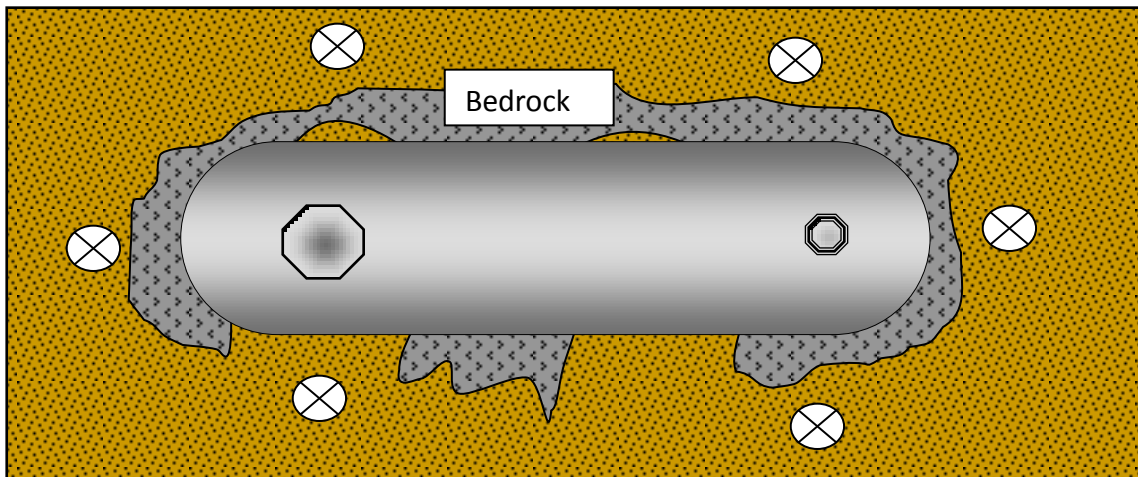

Figure 7

When bedrock is present, collect samples from the tank floor if and where sufficient (i.e., enough to fill a sample jar) native soil is present. Figure 7 above shows possible sample locations if native soil directly beneath the tank is not sufficient. If there is insufficient native soil on the tank bed floor, collect samples according to fill in place procedures or for soil sampling with a concrete pad. The number of samples collected will depend on the capacity of the tank.

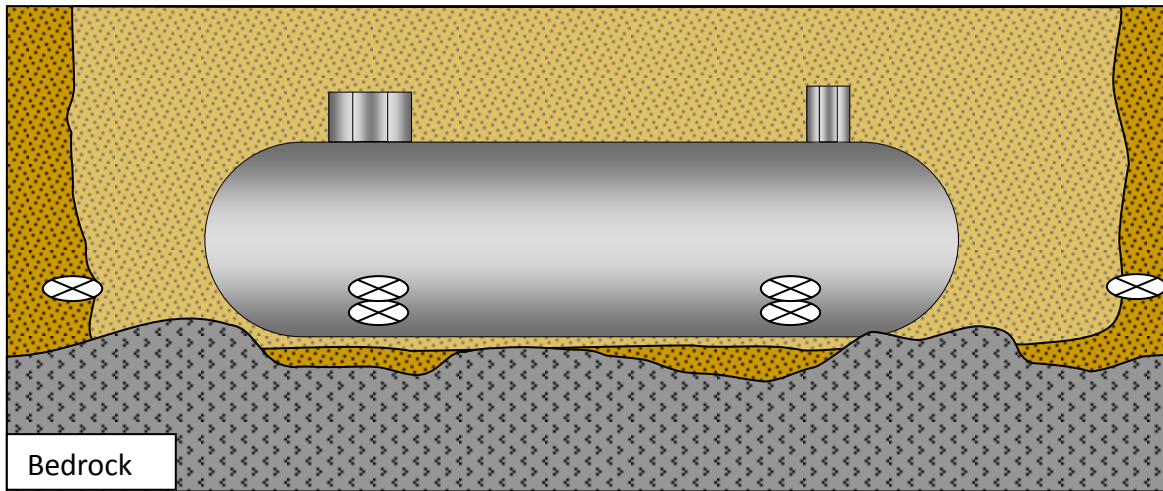

Figure 8

Figure 8 above shows tank bed sampling when bedrock is present, side view.

Tank Bed Sampling with Bedrock Present, Multiple Tanks

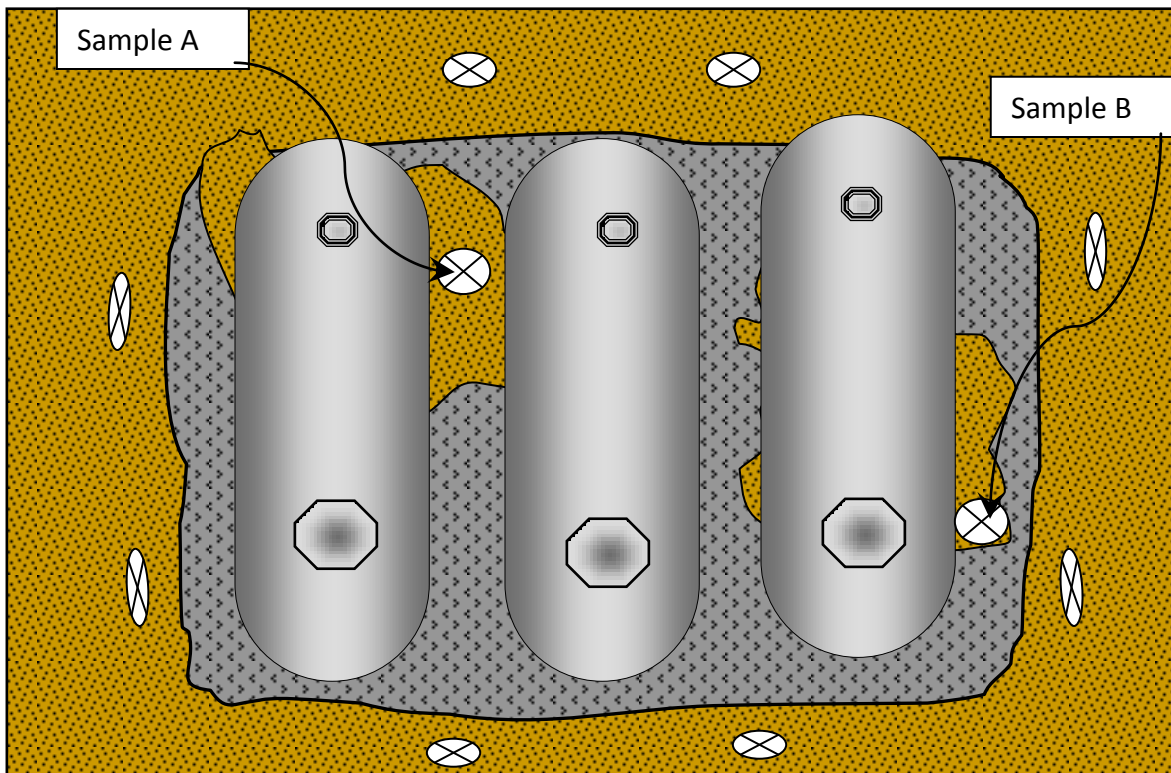

Figure 9

For tank bed soil sampling in bedrock, collect the soil samples from native soils if and where sufficient native soil is present. Figure 9 illustrates where samples should be collected if there is sufficient native soil in the tank bed (i.e. sufficient to fill a sample container). Sample A is collected near the fill port and Sample B is collected near the STP sump. In this example, where native soil is present in the tank bed, forego two of the sidewall samples nearest the floor samples collected. If there is no native soil present beneath the tanks,

collect the samples from the sidewalls just above the soil bedrock interface, and in line with fill port and STP sump. Document with photos the tank bed soil conditions and material.

Under no circumstances should one enter the tank pit to collect a sample. If there appears to be insufficient native material on top of bedrock, document with photos and forego tank floor sampling in favor of sidewall samples.

Sidewall samples at the ends of the tank are usually less important than samples collected in line with the STP sump and the spill bucket. Leaks on steel tanks commonly occur where there are seams or welds and along the bottom so use your professional judgement when it collecting samples at the ends of tanks. Obviously, if you see perforations or spot corrosion and deep pitting at the end of a tank when it is removed, you need to collect a sample at that location. Tanks filled in place, on the other hand, require sampling at the ends.

Tank Bed Sampling with Concrete Pad Present

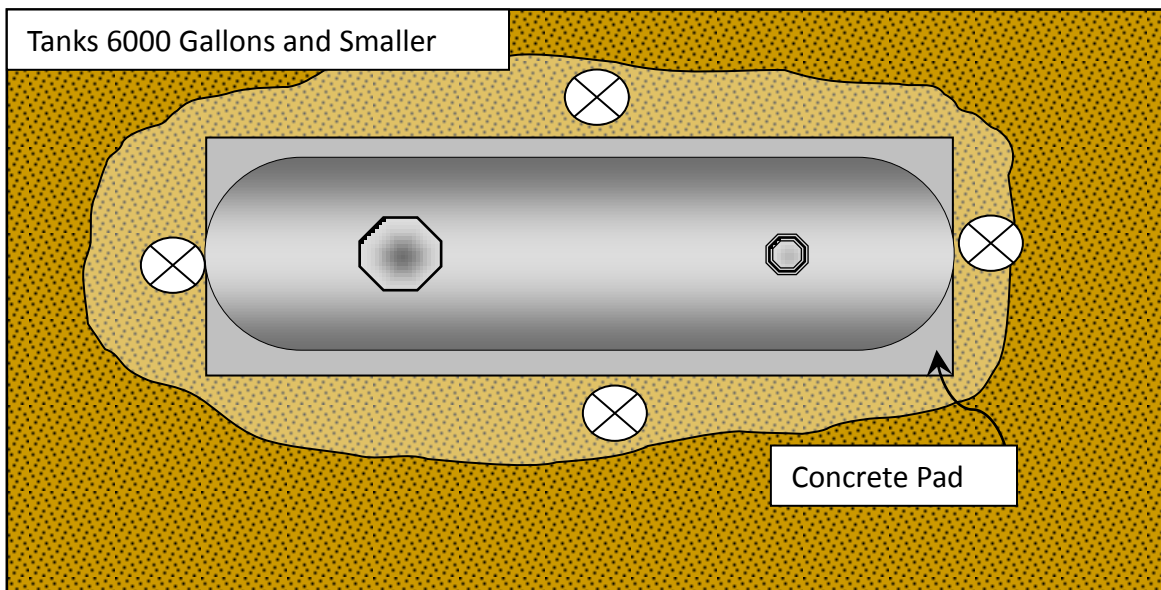

Figure 10

When a concrete pad interferes with sampling directly beneath the tank, collect samples around the side per fill-in-place procedures. Sampling in Figure 10 is for tanks 6000 gallons or smaller capacity. Collect samples as close as possible to the pad, one to two feet into native soil.

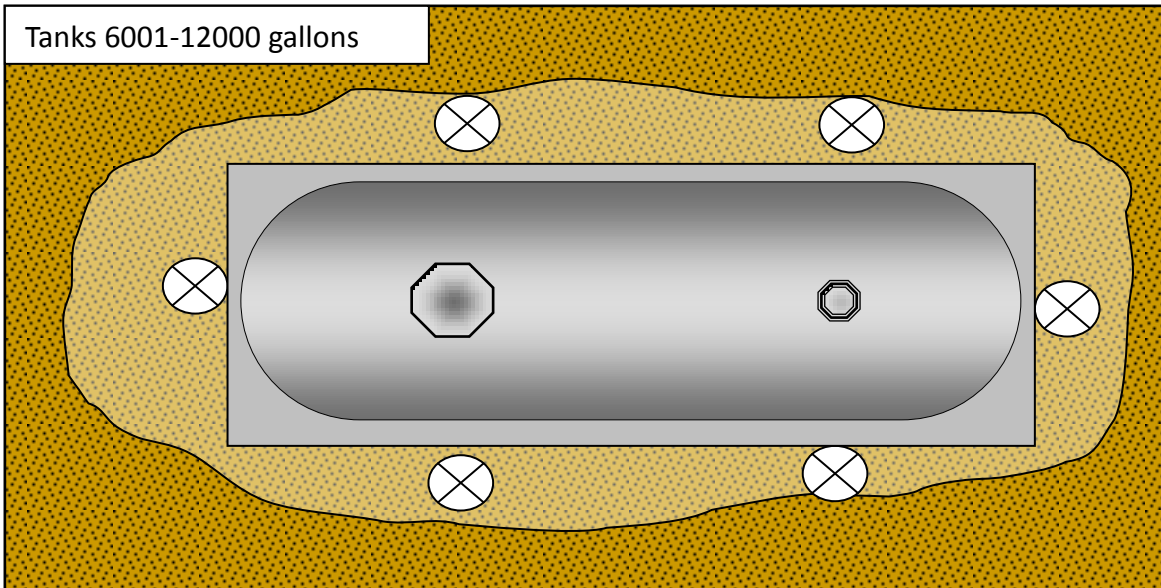

Figure 11

Figure 11 above shows the number of samples for a tank between 6001 and 12000 gallons capacity. Collect samples as close as possible to the pad in line with the spill containment and the STP sump, one to two feet into native soil. Collect one sample from each end.

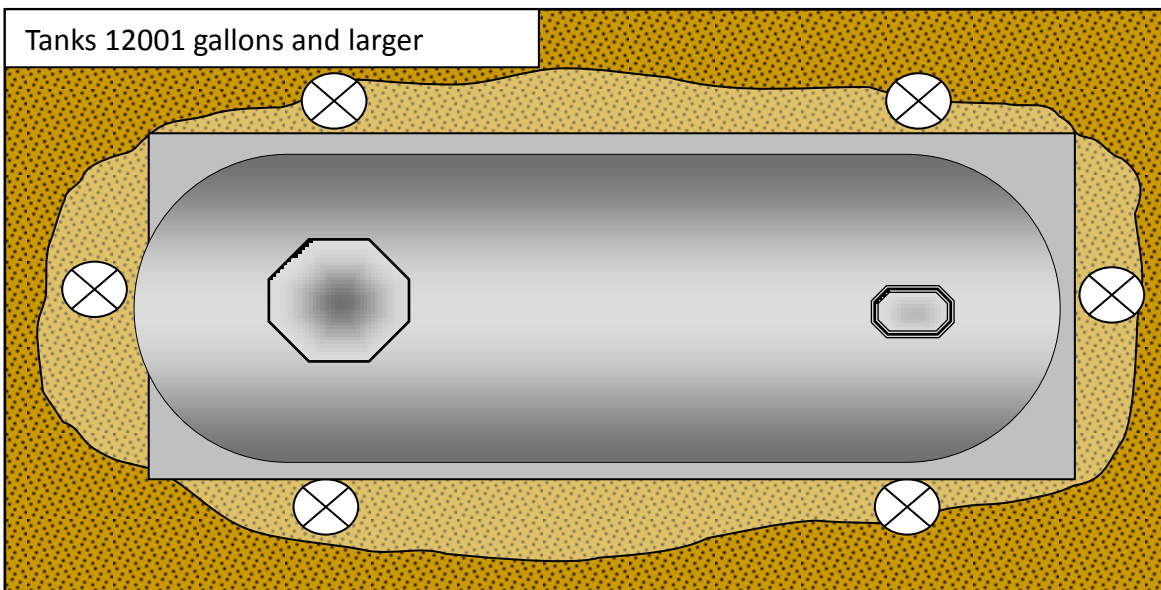

Figure 12

Tank Bed Sampling with Multiple Tanks and Concrete Pad

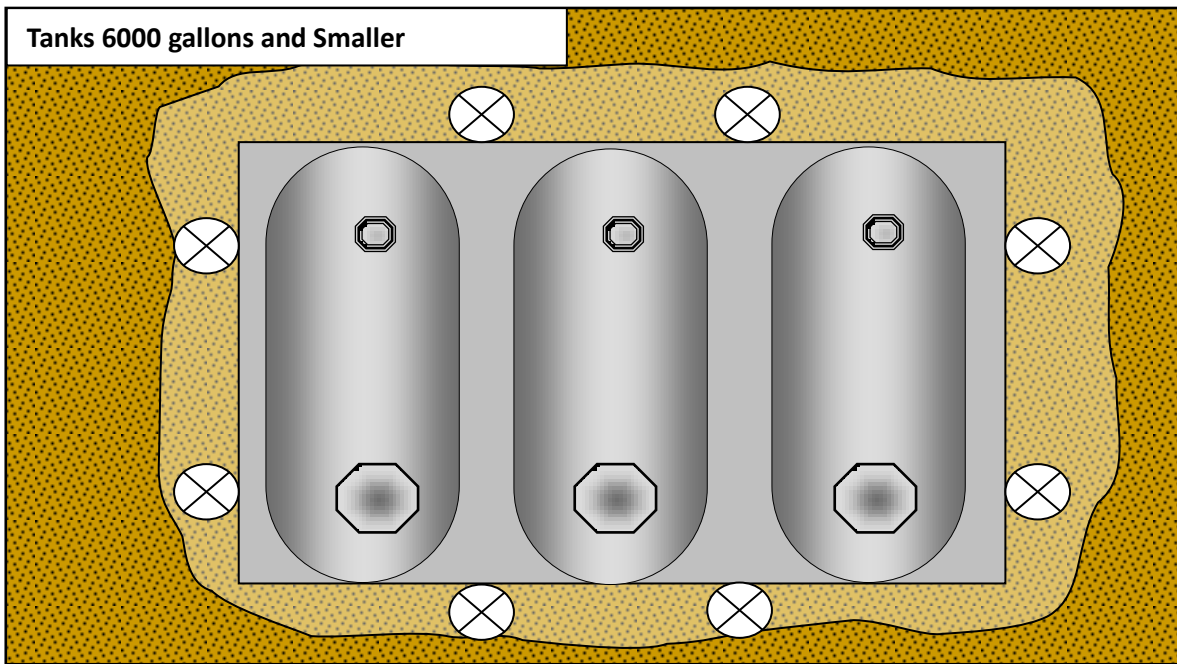

Figure 13

If a concrete pad was installed under a bed of tanks for anchoring, sampling locations depend on the presence of apparent contamination and staining around the perimeter of the pad. If there is no apparent contamination, collect soil samples as in Figure 13. The most likely areas for a release to occur are at the fill port and the spill bucket, and then along the ends and bottom of steel tanks. If the tank is double wall steel or fiberglass, the chance of a release occurring at the end and bottom of the tank is very low. However, a single wall steel tank with flat welded ends would obviously have a greater chance of a release occurring at the ends and bottom of the tank. Previous sample requirements included sample locations at the ends of each tank and one along the sides. Experience tells us releases don't occur in the middle of a tank. Therefore, the locations above reflect the likelier places where a release will be detected. If there is a release at the ends of the tanks, it should be detected by the two sample locations at the ends. Three samples, one at each end is not necessary. Instead, sample in between the tanks.

Sample as close as possible to the pad with one sample from each tank end and one sample collected along the length of each of the outer tanks. Figure 13 above shows sampling locations for tanks 6000 gallons and smaller. Forego samples from the ends of the outer tanks if tank ends are intact (no perforations, deep pitting, or cracking) and no staining and collect an extra sample along the sidewalls of the end tanks in line with the STP sump and the spill bucket.

For tanks between 6001 and 12000 gallons capacity, collect two soil samples from the sides as in Figure 14 below the tank and in line with the STP sump and fill port. Collect one sample between the tanks at the ends as close as possible to the concrete pad, one to two feet into native.

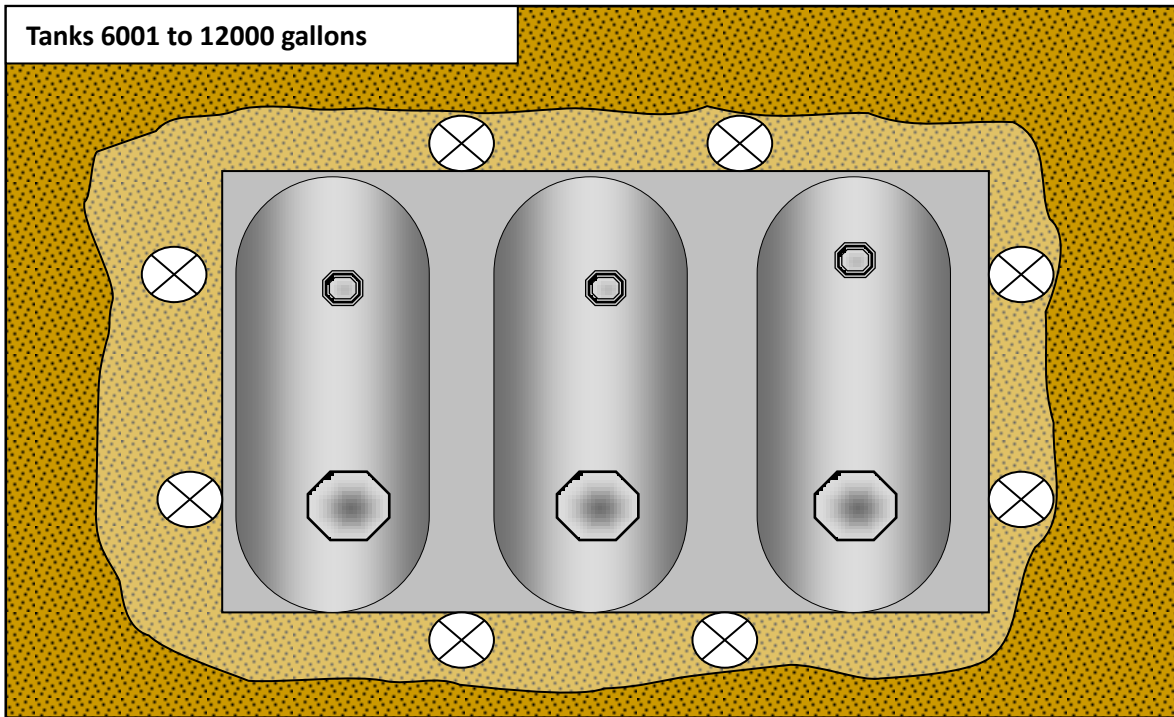

Figure 14

For multiple tanks greater than 12000 gallons in a tank bed with a concrete pad, collect an additional soil sample in the middle of the outer tanks as close as possible to the concrete pad as in Figure 15 below. If the ends of the two outer tanks are intact (no staining, no cracks, deep pitting or perforations), forego soil samples at those locations and sample between the tanks.

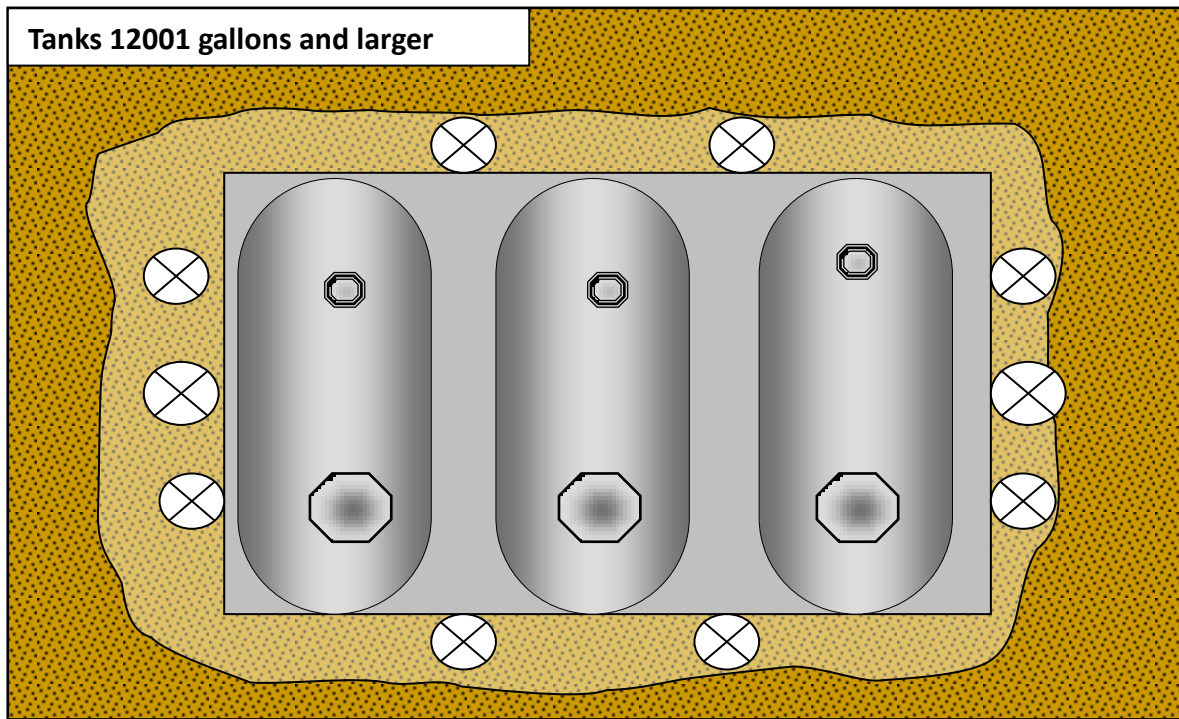

Figure 15

When Groundwater Interferes with Soil Sampling

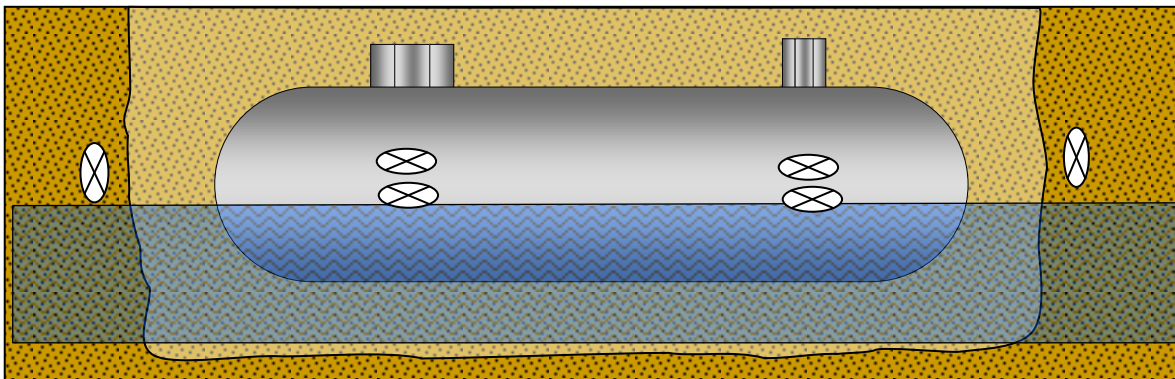

Figure 16

If groundwater is present in the tank pit, do not take confirmatory soil samples from the bottom of the tank excavation. Collect samples from the long walls of the excavation immediately above the soil-water interface according to fill-in-place procedures or when a concrete pad interferes with sampling beneath the tank, as in Figure 10 - Figure 15. Soil sampling is not so critical at the ends of the tanks unless deep pitting and perforations are observed. If the tank is 6000 gallons or smaller, collect one sample at the midpoint of the tank, one to two feet into the long wall. If the groundwater level is higher than the top of the tank, soil samples are not required. Collect a downgradient groundwater sample outside the tank pit, but within 20 feet.

For tanks larger than 6000 gallons collect the sample in line with the STP sump and the spill containment as in Figure 16 above. If contaminated soils are visible anywhere in the excavation side walls, additional samples must be collected from the stained areas. The number of samples is determined by the size of the tank as in fill-in-place procedures or when a concrete pad interferes with soil sampling.

Soil Sampling for Product Piping Closure

The following guidelines are for soil sampling beneath product piping during closure. At a minimum, soil samples must be analyzed for benzene, toluene, ethylbenzene and xylenes and OA-2 group chemicals if applicable. All confirmatory soil samples must be discrete samples collected in the native soil one foot below the product piping.

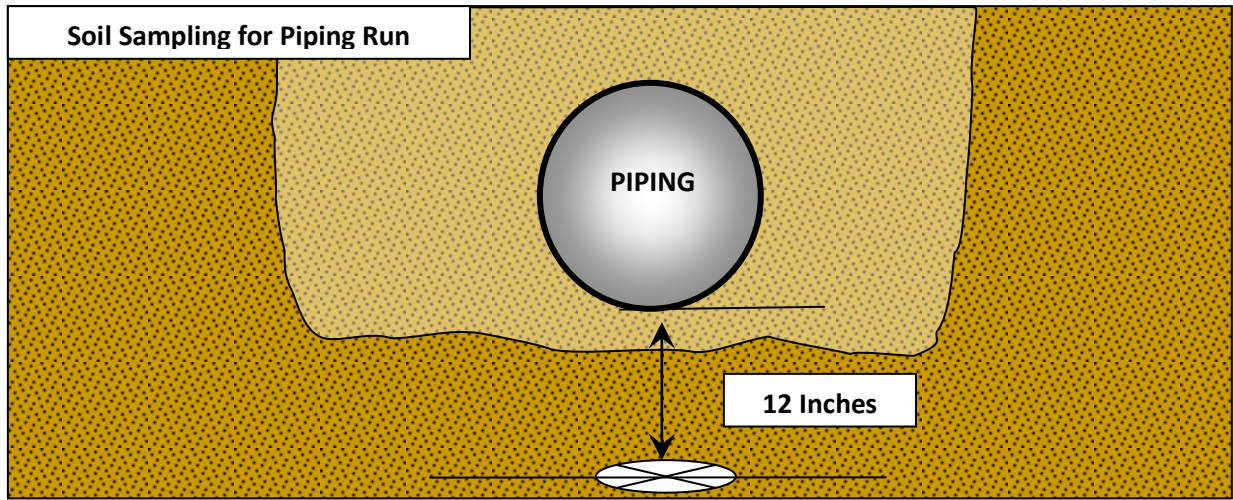

Figure 17

For a single product line in an open trench, collect a sample in the middle of the product line. Collect each soil sample along the product piping from a depth of one foot below the piping into native soil as shown in Figure 17 above.

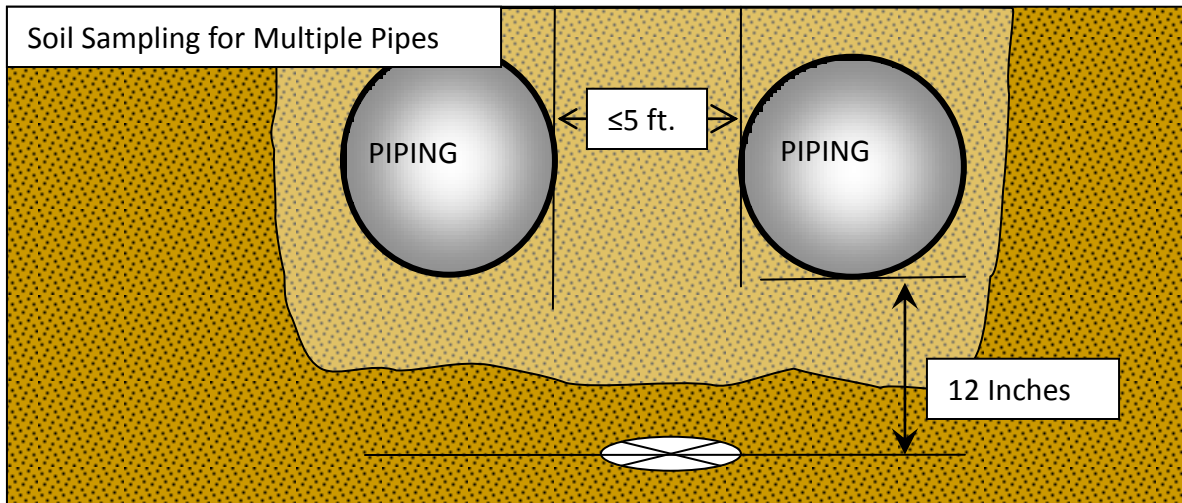

Figure 18

When the distance between two or more piping runs in an open trench is five feet or less, collect one sample in the middle of the piping run, one foot into native soil as shown in Figure 18.

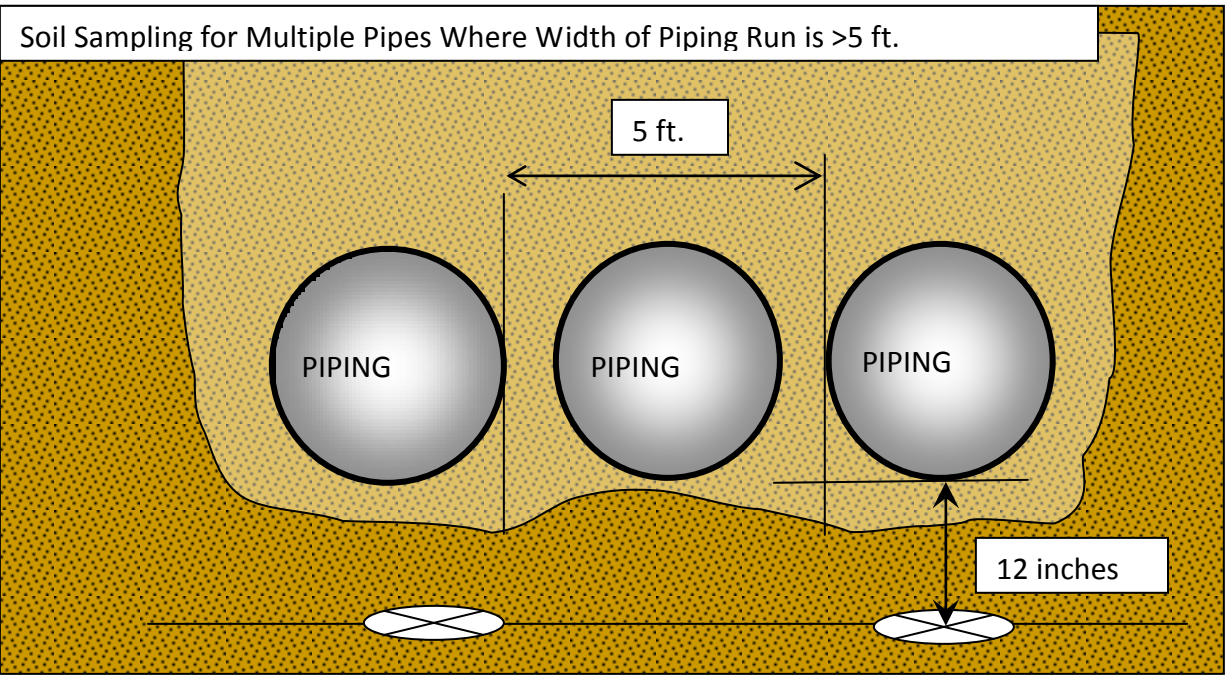

Figure 19

If the width of multiple pipe runs is greater than five feet, collect two samples in line with each other and with a five foot separation distance. Collect each soil sample along the product piping from a depth of one foot below the piping into native soil as shown in Figure 19.

Exposed or Open Trench and Removal of Piping (Single Wall)



Photos courtesy of SD Petroleum Release Compensation Fund

Follow these guidelines for taking soil samples from along single wall piping when the piping trench is exposed (excavated) and the piping to be removed is available for inspection.

- Collect one confirmatory sample into native soil directly below each swing joint, flex connector, union, tee and pipe elbow, if one exists (**piping includes product line and remote fill piping**). Confirmatory soil samples should be collected at a minimum depth of one foot below the product piping.
- In addition, examine the piping for damage (structural, physical or mechanical weakness or perforation). Thoroughly inspect and evaluate the soil conditions at the point of any apparent weakness in the piping. Collect a sample into native soil at any point of apparent damage and/or release.
- Inspect the open trench for any areas where there are indications that a release may have occurred. If evidence of contamination is observed, collect a soil sample from the contaminated area for analysis. Make sure the sample is collected from native soil and not backfill. If there appears to be extensive contamination, field screen every two feet through the area of contamination and submit one soil sample for analysis from the area with the highest field screening results for every 10 feet of screening. Submit field screening results with the closure report.
- If there is no indication of a release, or obvious contamination along the product piping, and there are no connections such as swing joints, flex connectors, unions, tees or pipe elbows, no confirmatory soil sampling is required; however, you must submit photos of the exposed trench and all piping with the closure report. If the trench is not fully exposed, or the piping is not available for inspection at closure, follow the guidelines for closed trench and abandonment of piping.

Closed Trench and Abandonment of Piping (Single Wall)

Piping closure in place does not allow for a thorough inspection and visual evaluation of soil conditions in the piping trench. In this situation, follow these guidelines for taking soil samples from along single wall piping in a closed trench.

- Collect a confirmatory soil sample below each swing joint, flex connector, or pipe elbow as they are known to exist or every 10 feet along the piping. Collect the sample(s) one foot below the piping into the native soil. If two or more product lines are known to run parallel and within five feet of each other, collect one sample in the middle of the piping run. Where the product line is less than 10 feet in length, one sample is still required.

Piping Run Sampling

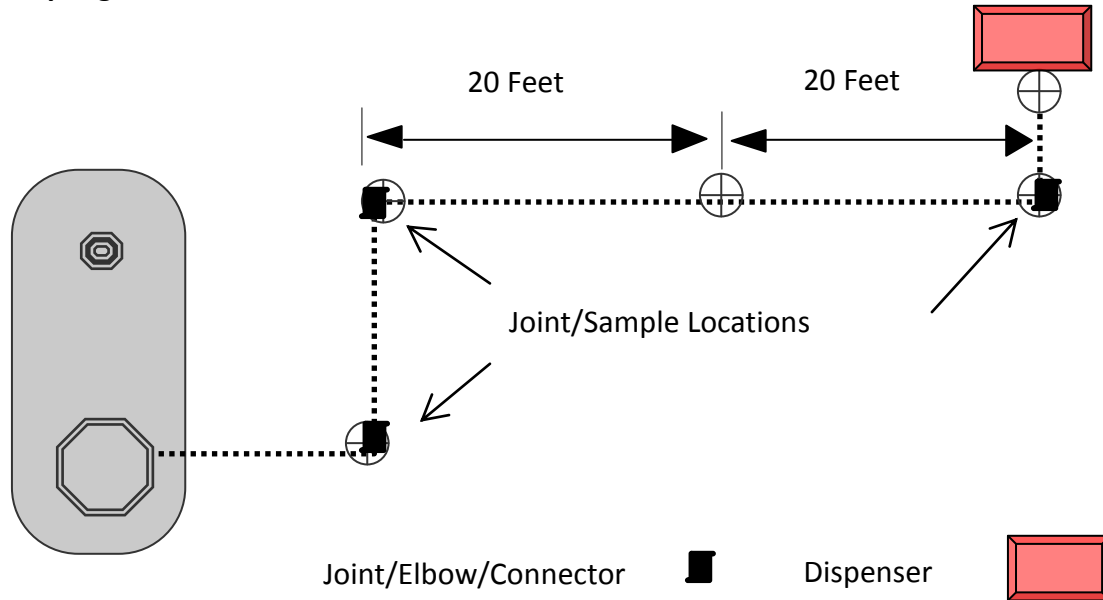

Figure 20

Illustrated above are sampling locations for closed trench (closure in place) piping closure. In this example, the department has allowed sampling every 20 feet instead of 10 feet as it is double wall piping. A sample is collected at each joint and/or every 20 feet. In Figure 20, soil samples are collected at three joints and in the middle of a 40 foot run of piping. Another sample is collected as close as possible to the dispenser for a total of five samples.

Exposed or Open Trench and Removal of Piping (Double Wall)

Follow these guidelines if the piping trench is exposed (excavated) and the piping is to be removed.

- Collect a confirmatory soil sample directly below each transition sump, if one exists, at a depth of five feet below ground surface directly below the transition sump or within three feet of the sump.
- Examine the piping for damage (structural, physical or mechanical weakness or perforation) and inspect and evaluate the soil conditions at the point of any apparent weakness in the piping. Collect a soil sample along the product piping wherever there is obvious staining or indications a release may have occurred. If piping is not damaged, and contamination is not apparent, confirmatory sampling is required only beneath the transition sump (if one exists).

Closed Trench and Abandonment of Piping (Double Wall)

Piping closure in place does not allow for a thorough inspection and visual evaluation of soil conditions in the piping trench. In this situation, follow these guidelines for conducting a line test or taking soil samples from along double wall piping.

- If double wall semi-rigid (flexible) piping is abandoned in place, a precision line test (0.1 gph leak rate) conducted by a third-party after the tanks have been emptied which demonstrates the product line(s) (both PRIMARY and SECONDARY) are tight, may be used for the site assessment instead of native soil

sampling. If either primary or secondary pipe fails the tightness test, sampling of native soil is required per closed trench single wall requirements (see Figure 16).

- In lieu of precision testing, sampling must be collected per closed trench requirements (see Figure 20).

If water is encountered in the piping trench before the one-foot depth for sampling, do not attempt to collect soil samples below the piping. Collect a downgradient groundwater sample.

Product piping that is taken permanently out-of-service and is located in a common trench with other piping that will remain in service, does not have to be assessed for closure until all the piping in the common trench is permanently closed. Piping that is to be permanently closed must be purged and capped.

Soil Sampling Beneath the Dispenser (With and Without Containment)

During UST system closure or piping only closure, collect a soil sample beneath or as close as possible to the dispensers (within 5 feet). Of course, when dispensers, sumps and concrete islands are removed, access beneath the dispenser is much easier. A hand auger or excavator should be able to collect a sample one to two feet below the dispensers into native soil. No field screening is necessary for dispenser samples. If dispensers are closer than five feet, collect one sample in between.

If it is not possible to sample directly beneath the dispenser, place the boring no more than five feet from the dispenser in the apparent downgradient direction. The boring should be advanced to at least one to two feet into native soil or one to two feet below the UDC. Field screening is not necessary. If there are five or fewer feet separating the dispensers, collect one sample between them instead of one beneath each one.

If the product dispensers are within the tank field area, dispenser samples are not required.

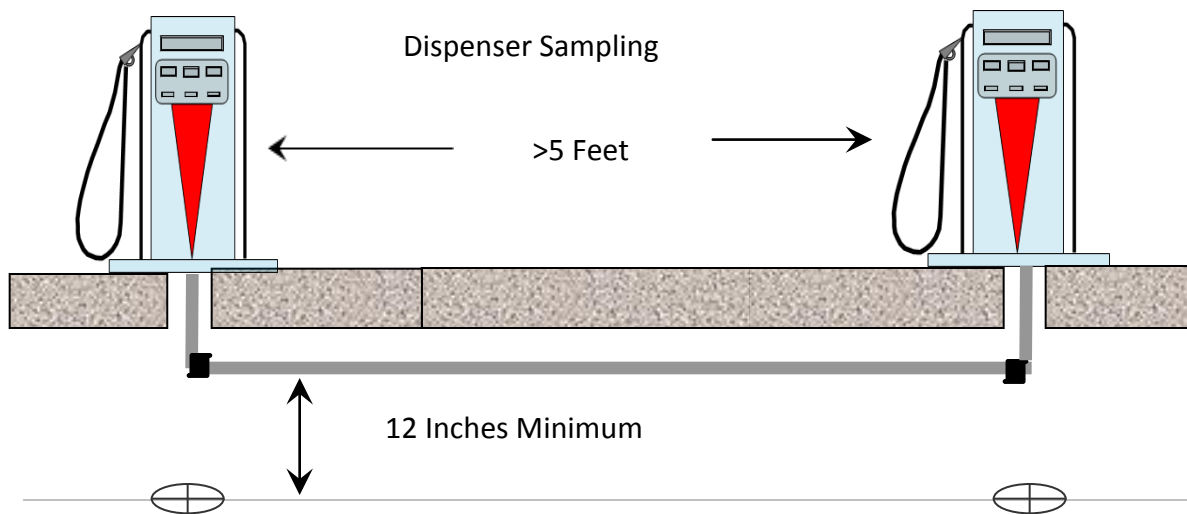

Figure 21

Soil Sampling Beneath the Remote Fill Containment

If the fill port (spill containment) is located five or more feet from the tank pit, collect one sample two feet into native soil below the fill opening as shown below in Figure 22.

The remote fill line is considered product piping; sample in accordance with requirements for product line closure.

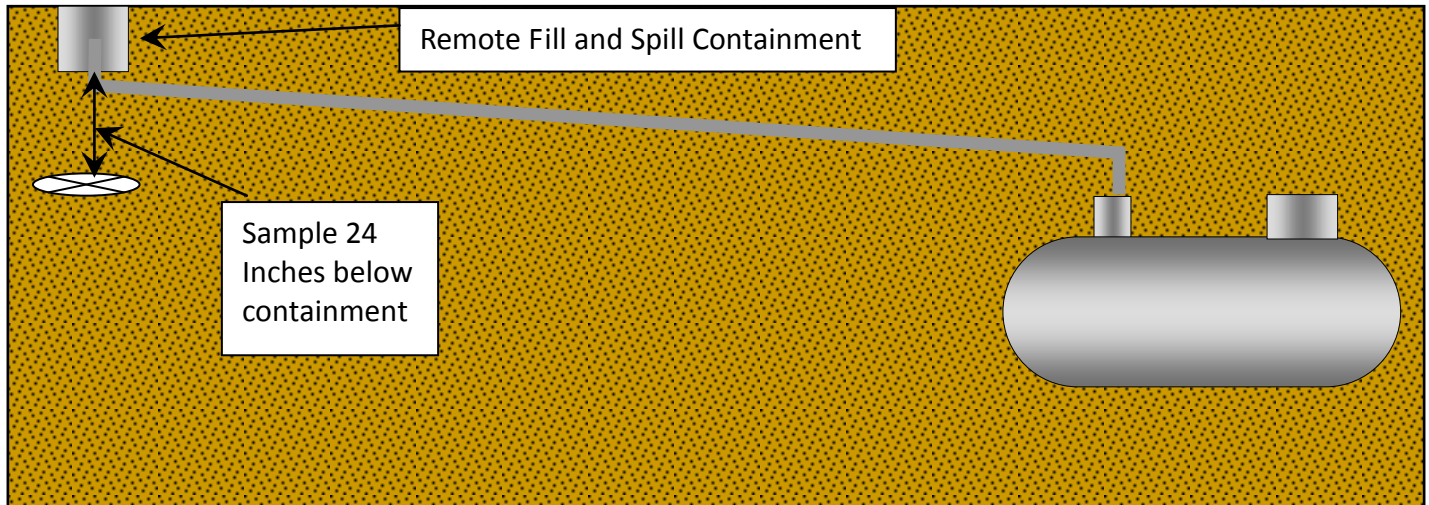

Figure 22

Groundwater Sampling Requirements

Collecting water from the bottom of a tank excavation and placing it in a bottle does NOT meet groundwater sampling requirements. Groundwater samples must be taken from a monitoring well located OUTSIDE the tank excavation. The monitor well must be located within 20 feet of the presumed “downstream” or “downgradient” side of the UST system. That is, the well must be located so that it would sample any contaminated groundwater flowing away from the storage system. The downgradient direction is determined by local surface topography where assessment reports with groundwater flow direction are nonexistent. Groundwater monitor wells must also be able to detect contamination from the piping and dispensers as well as the tanks, so more than one monitor well may be required.

When they are no longer needed, monitor wells must be properly abandoned to prevent possible surface contamination from flowing down the well directly into groundwater. A well contractor or CGP should use special equipment to fill the well from the bottom with neat cement or a bentonite mixture.

Groundwater Sampling Equipment

Typically Includes:

- 1) A drill rig or auguring tool or drilling rig capable of boring to groundwater. A clean, commercially manufactured sampling device that is transparent and compatible with the substance stored in the tanks.
- 2) Several sampling containers with screw-top Teflon-lined lids obtained from the laboratory that will conduct the analysis.
- 3) Equipment to maintain the groundwater samples at approximately 40 degrees Fahrenheit from the time the samples are taken to the time when the samples are delivered to the laboratory.
- 4) A scrub brush, detergent and a supply of distilled water to clean the sampling equipment after each sample is taken.

Procedure for Groundwater Sampling

- 1) When there is only one tank or there are several tanks in a single excavation, the monitoring well should be installed at the midpoint of the downgradient side of the excavation. If the tanks are in a "cluster" where the tanks are not in the same excavation but the tanks are 10 feet or less apart, they may be treated for groundwater sampling purposes as a single excavation. If the tanks are more than 10 feet apart, more than one monitor well may be required.
- 2) Field screening instruments must be used to determine the vertical extent of soil contamination and assist in selection of samples for laboratory analysis. Screening measurements must be made along the entire length of the boring, and drilling must continue until the contamination is no longer detected (vapor readings are below 10 ppm). Acceptable field vapor screening instruments include photoionization detectors (PID), flame ionization detectors (FID), or other similar vapor analyzers. Equipment must be calibrated according to the manufacturer's instructions at the beginning and end of each day. Observations of odor, staining, and vapor screening results must be documented on the boring logs.
- 3) After a well is completed and allowed to stabilize, determine the static water level (SWL) and presence or absence of free product using an oil/water interface probe or other appropriate equipment.
- 4) Monitoring wells must be purged of stagnant water in the casing prior to collecting a sample for analysis. Purging must continue until water quality measurements have stabilized. Once the well has been sufficiently purged, groundwater should be allowed to recharge to the original measured static water level before a sample is collected.
- 5) Collect a sample of the water by lowering a bailer into the monitor well until the top of the bailer is just above the surface of the groundwater. Retrieve the bailer, and check for the presence of free product or a sheen floating on the sample's surface. If sheen or free product is observed, contact the DNR at 515-725-8200 immediately. If no sheen or free product is observed, fill the sampling container provided by the laboratory with water from the bailer.
- 6) Label the sample according to the well labeling that you used in drawing the map of the well locations, and include on the label the date, facility name, tank owner's name, and substance stored in the tank. Fill each container so that there is no air space, but do not overfill. Secure the lid on each container after filling. Repeat the sampling procedures above for each monitor well. If the same bailer is to be used to sample more than one well, the bailer must be thoroughly cleaned with soap and detergent, and rinsed with distilled water prior to sampling each additional well.
- 7) Prepare the samples for delivery to the Iowa certified laboratory by placing the containers into an iced cooler or chest maintained at approximately 40 degrees Fahrenheit. Samples must be shipped so that they will arrive at the laboratory within 72 hours of collection. The Iowa certified laboratory listing may be found at www.iowadnr.gov/ust.

Laboratory Procedures for Testing Soil and Groundwater Samples

Regardless of the product stored in the tank, soil and groundwater samples must be analyzed for volatile petroleum compounds (gasoline) with concentrations of benzene, toluene, ethylbenzene, and xylene (BTEX) reported separately using analytical Method OA-1. In addition to this analysis, if the storage system has stored any liquid other than gasoline (for example, diesel, kerosene, fuel oil, mineral spirits, used oil), or if it is unknown whether any liquid other than gasoline was stored in the tank, soil samples must also be analyzed for Total Extractable Hydrocarbons using Method OA-2.

For tanks containing non-petroleum regulated substances, the laboratory analysis must be suitable for detecting the substance stored and its breakdown constituents using the appropriate EPA and DNR approved analytical methods.

Contaminant Corrective Action Levels

Soil and groundwater samples with contaminant concentrations exceeding the action levels in the table below may require further investigation and/or corrective action. The owner/operator, insurance company, and Certified Groundwater Professional will be notified in a letter if there are additional requirements.

Volatile Hydrocarbons	Soil Action Level (mg/kg) ppm	Groundwater Action Level (ug/L) ppb
Benzene	0.54	5
Toluene	3.2	1000
Ethylbenzene	15	700
Xylene	52	10000
Low Volatility Hydrocarbons		
Waste Oil	No Limit	400
Diesel	3800	1200

Groundwater Sampling Requirements

Due to the size and layout of some UST sites, more than one groundwater monitoring well may be necessary. Figure 23, below, shows a UST site with a 40 foot long 20000 gallon UST and two 10000 gallon USTs. The layout is roughly 80 feet wide. Downgradient flow is to the south. One monitoring well located in the middle and to the south of the site is insufficient to capture a release from any part of the UST layout. A more accurate approach would be to split the site in the middle at 40 feet and locate a well in the middle of each 40 foot section. Wells must be outside the tank pit, but within 20 feet.

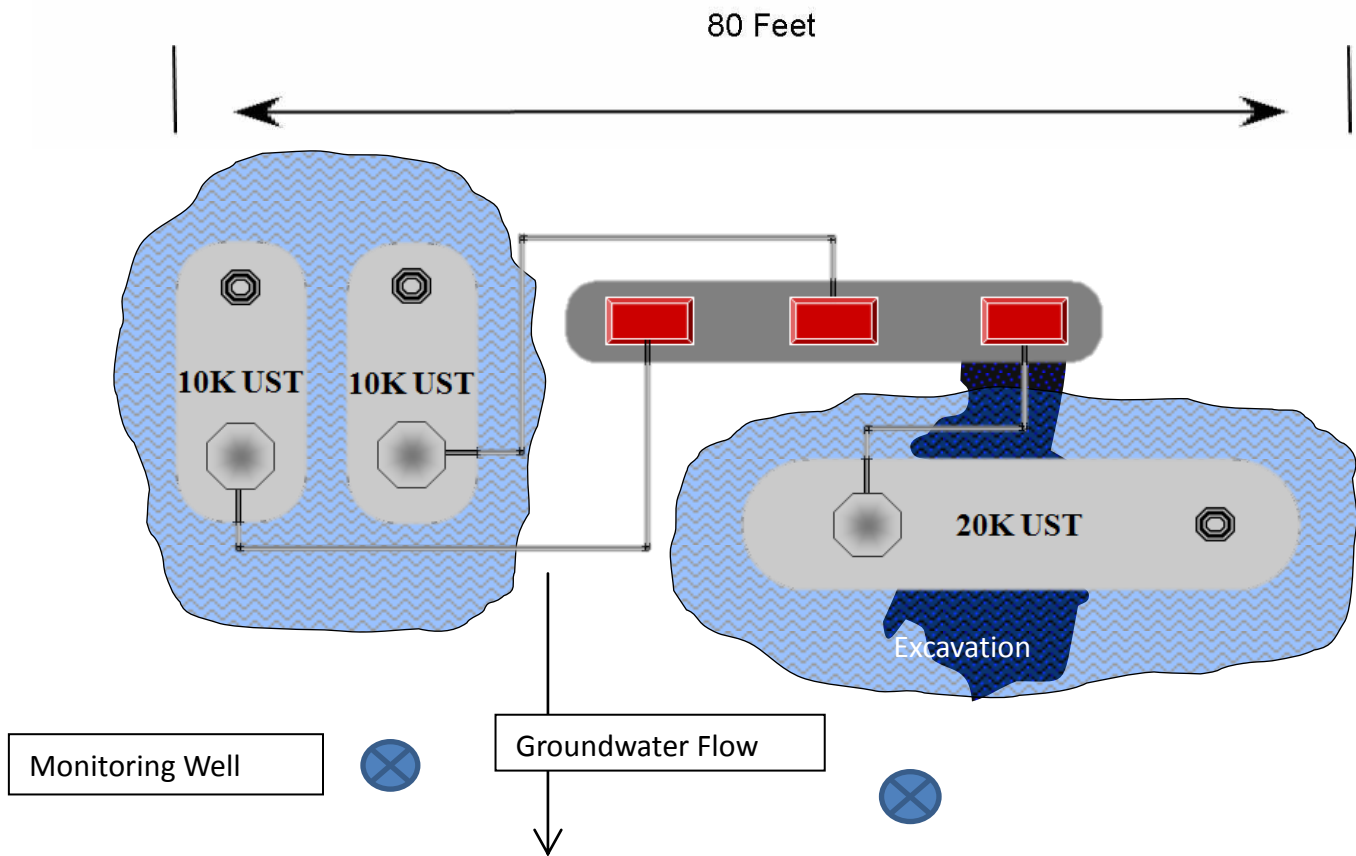

Figure 23

There are so many varied UST layouts that not all can be depicted in a diagram. There are often obstructions and limited space, which may make well location difficult to determine. This is why the department relies on the professional judgement of the CGP to determine the groundwater flow, number and placement of the monitoring wells.

In Figure 24, groundwater flow is to the northeast. Two monitoring wells again should be sufficient to capture a release from any part of the UST system. The monitoring well on the left is outside the tank pit, but within 20 feet of the tank pit. The monitoring well on the right will capture a release from the dispenser island and the 20000 gallon tank.

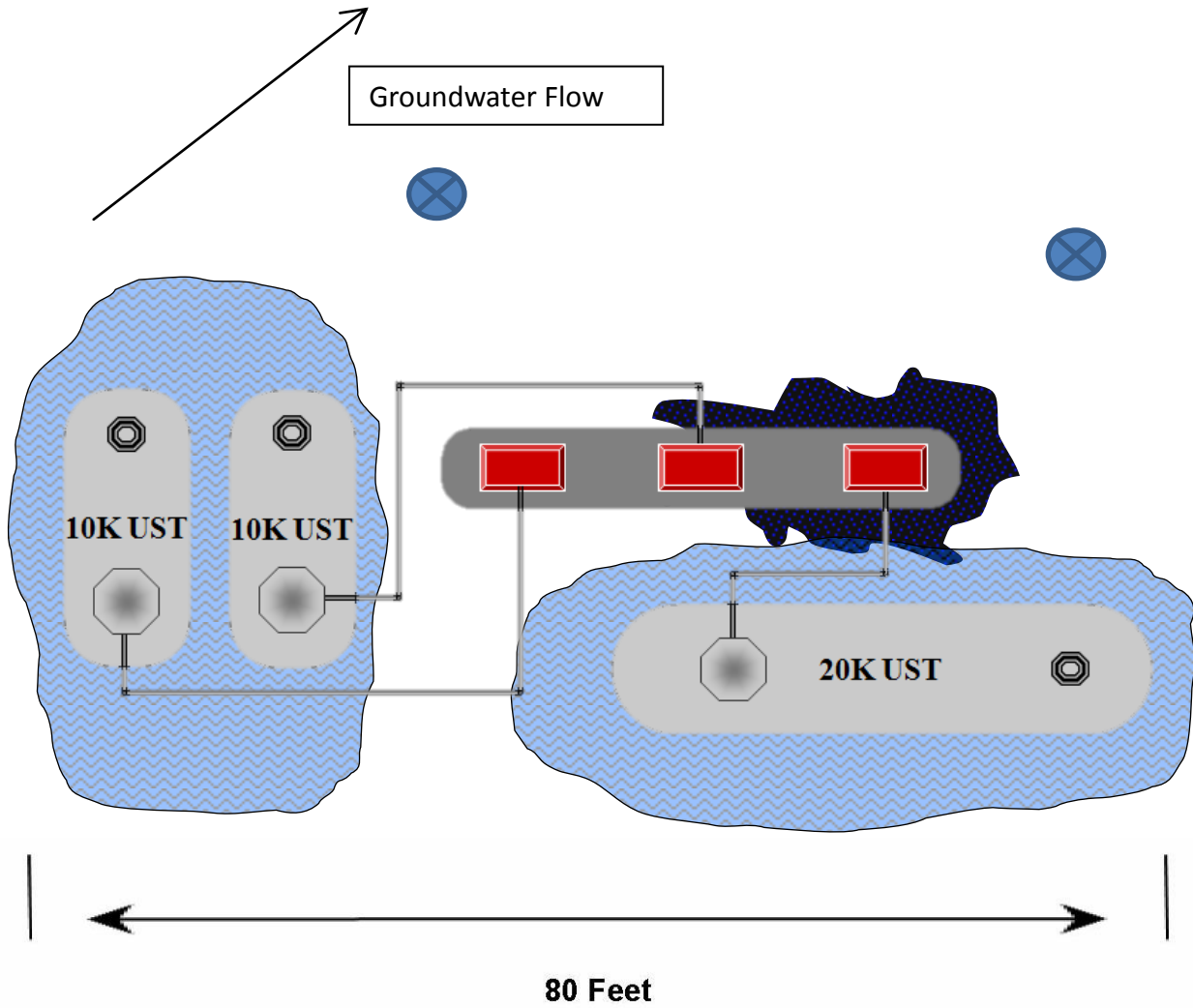

Figure 24

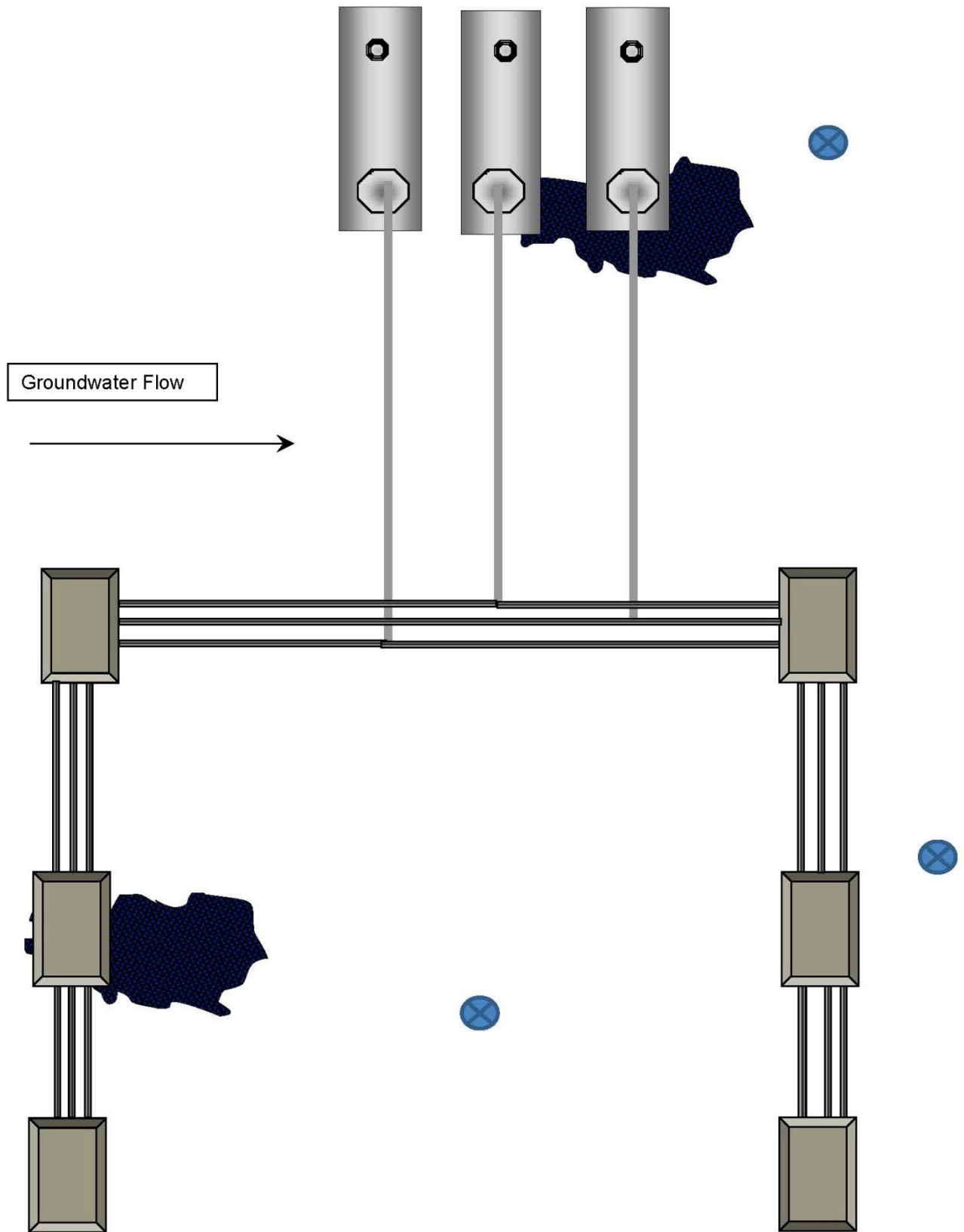

Figure 25

This is a large dispensing area with groundwater flow to the east. Obviously, one monitoring well is not sufficient to cover a release from the tank bed and the dispensing area. Two wells would be acceptable, but a third monitoring well placed in the middle of the dispensing area would be preferred.

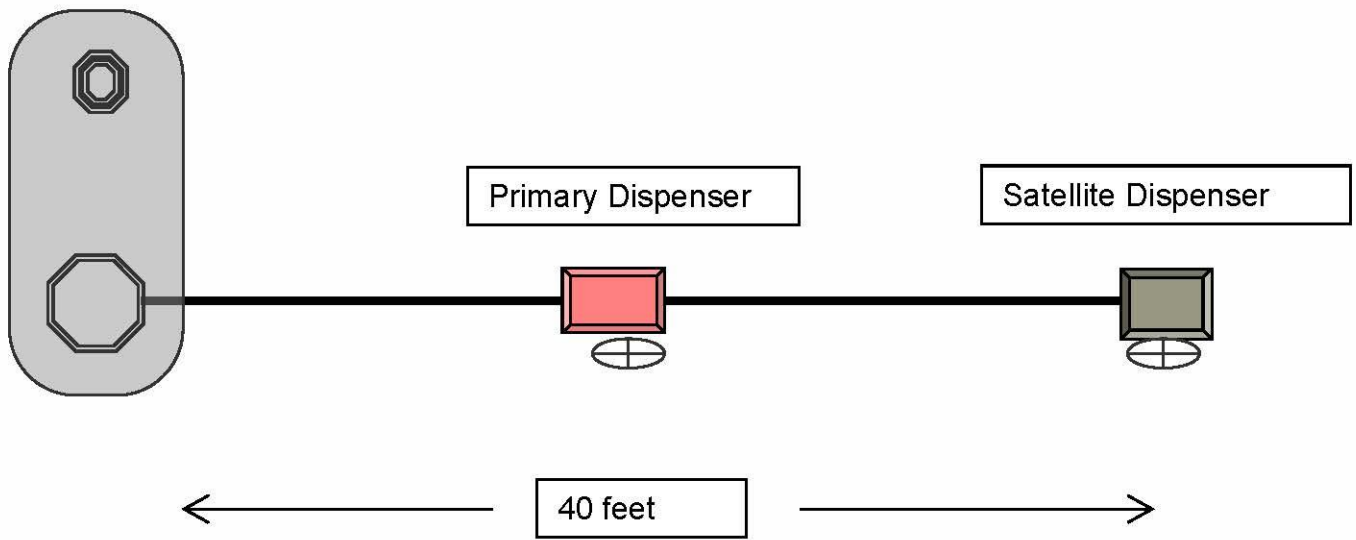

Figure 26: Don't neglect the satellite dispenser. Collect one sample beneath the satellite dispenser.

Thanks to the Wisconsin DNR for providing us with the diagram pieces with which to assemble the graphics in pages 35 through 56.

Soil Sampling Locations Summary—Groundwater Not Encountered

(Closure by UST Removal)

TANK CAPACITY (Gallons)	# OF SAMPLES	LOCATION
1,000 or less	1	Center of Tank
1,001 to 8,000	2	In line with STP sump and Fill Port
8,001 to 30,000	3	In line with STP Sump, Fill Port and at Center
30,001 to 40,000	4	In line with STP Sump, Fill Port, Center and 5 feet from downgradient end
40,001 or greater	5	In line with STP sump, spill bucket, center and 5 feet from ends
Product Dispensers	1	Take one sample directly beneath dispenser, one foot minimum depth below surface or one foot below UDC into native
Product Lines		Collect samples at a minimum depth of one foot into native
Remote Fill	1	Two feet below spill bucket

Soil Sampling Locations Summary—Water Encountered

(Closure by UST Removal)

TANK CAPACITY (Gallons)	# OF SAMPLES	LOCATION
1,000 or less	2	Collect soil samples just above soil/water interface along each long wall of excavation in line with spill bucket and STP sump. For tanks greater than 30000 gallon capacity collect one soil sample at each end of tank.
1,001 to 8,000	2	
8,001 to 30,000	4	
30,001 to 40,000	6	
40,001 or greater	6	
Product Dispensers	1	
Product Lines		Collect samples at a minimum depth of one foot into native
Remote Fill	1	Two feet below spill bucket

Soil Sample Locations Summary for Filling in Place, or When a Concrete Pad Interferes with Sampling beneath the UST

TANK CAPACITY (Gallons)	# OF SAMPLES	LOCATION	EXAMPLE (“X” = Location of Sample)
6,000 or fewer	4	One from each end and one from each side	
6,001 to 12,000	6	One from each end and two from each side in line with spill and STP sump	
12,001 or greater	8	One from each end and three from each side at center and in line with spill bucket and STP sump	

NOTE for sampling with concrete pad present: sample between one and two feet into native soils as close as possible to the pad. Samples at ends of tanks are not necessary if there are no perforations, cracks or deep pitting, and petroleum staining is not observed.

Sampling Exceptions

Soil and groundwater sampling must be conducted at every tank and piping closure. The one exception is: an external leak detection method has been used. If DNR approved external leak detection equipment (e.g., ground water or soil vapor monitoring) has been in use on the UST system for a minimum of 90 days prior to the date of receipt of the closure notice by the DNR, analysis of soil samples for contamination may not be required. To qualify for this exception, the leak detection equipment must be operational, the required monitoring must have been conducted, and proper records must have been maintained.

If these external leak detection requirements have been met, the soil and groundwater sampling requirements may be satisfied by submitting to the department:

- 1) Form 542-1308 (Notice of Closure or Change-in-Service)
- 2) A description of the monitoring method used,
- 3) A complete record of the monitoring results for at least the previous 90 days,
- 4) The specifications of the monitoring equipment,
- 5) A notarized statement from the owner verifying that no release to the environment has occurred.

Backfill

Clean tank backfill can be used to fill the excavation or as backfill for new tanks if it meets the tank manufacturer's backfill requirements. Contaminated backfill must be disposed of properly at sanitary landfills or land farming practice. Both applications require permitting and/or approval before contaminated soil can be properly disposed. Land farming is a procedure where contaminated soil is spread out in a special authorized area so that contamination can evaporate or be degraded by bacteria.

For additional information go to:

<http://www.iowadnr.gov/Environmental-Protection/Land-Quality/Solid-Waste/Solid-Waste-Permitting/Land-Farming>

Heavily contaminated backfill is often easy to identify based on staining and odor. Lesser levels of contamination may be less obvious and it may be difficult to distinguish "clean" from "contaminated" backfill. To determine whether soil is clean or contaminated, contamination levels should be determined using PID or FID instruments. PID or FID readings less than 10 ppm generally indicate that backfill is clean enough to remain onsite. Laboratory analysis of soil samples provides a more definitive assessment of soil contamination levels than field screening tools such as a PID or FID. Laboratory tests indicating that contaminant levels are less than Tier 1 screening values indicate that the backfill is clean enough to remain onsite. Tier 1 values are available for review in the Contaminant Corrective Action Levels section of the Closure Guidance.

Contaminated backfill must be properly managed according to 567--Chapter 120 IAC. If there is a question about whether the backfill can be returned to the tank excavation, contact the DNR regional office or the DNR central office in Des Moines. Landfarming is a regulated activity, and proper procedures must be followed. Prior to landfarming contaminated backfill, a permit from the DNR's Solid Waste Section must be obtained according to 567-Chapter 120 IAC. The DNR issues two types of landfarming permits:

- a. Multiuse landfarming permit. As the name indicates, a multiuse landfarming permit is issued for a facility designed to be used for more than one application of petroleum contaminated soils (PCS). This type of permit requires that each application of a particular source and type of PCS be treated in separate landfarm plots. A multiuse landfarming permit is not issued to a facility located at a sanitary landfill.
- b. Single-use landfarming permit. A single-use landfarming permit is issued to a facility where a given plot of land can be used for landfarming contaminated soil only once. Landfarming operations can be conducted on adjacent plots of land that are at least 15 feet apart, but each plot can be used only once.

A landfarming permit is not required if less than 3 cubic yards of contaminated soil are to be treated.

For a permit application or a list of already approved landfarm sites, call 515-725-8350 or visit <http://www.iowadnr.gov/Environmental-Protection/Land-Quality/Solid-Waste/Solid-Waste-Permitting/Land-Farming>

Petroleum contaminated soils may be accepted for remediation at a local sanitary landfill provided the landfill management is authorized by the Solid Waste Section of the DNR. The landfill should be contacted prior to delivery of the contaminated soil. Ask for weight tickets and disposal receipts to document proper disposal of the soil. For additional information call the Solid Waste Section of the Department of Natural Resources (515-725-8200).

Up to one (1) foot of the native soils surrounding the tank excavation may be removed without triggering corrective action regulations. If contamination is limited and localized, it may be practical and economical to remove this additional one foot of native soil. Confirmation samples taken after the one foot of soil has been removed should be collected from the areas showing the greatest contamination to determine whether further remediation will be required. If this limited excavation of native soil has been conducted, it must be reported to the DNR before the excavation is backfilled.

Soil removal beyond one foot of the boundaries of the tank excavation is considered *expedited corrective action*, and must be conducted according to DNR regulations (see 135.12(11)).

Tank Fill in Place

Filling tanks in place is less preferred than removal of the tanks. Any change of ownership in the property will have to face the fact that the tanks are still in the ground, albeit filled with an inert material instead of a petroleum product.

Filling in place may be just as expensive as removal. Even during fill in place, the overburden may have to be removed to access the tank top and to fill the tank completely with the inert material.

The tanks may interfere with construction in the future, and it is difficult to remove tanks that are filled with sand or mortar. Essentially, what remains after tanks are filled in place is a solid waste underground--not very attractive for a prospective buyer.

Nonetheless, when removal is hazardous due to utilities or other barriers or when it compromises another structure, to fill in place may be the only option.

The tank owner must submit the Notification of Closure Form (indicate *Fill in Place* on the form) 30 days before the tank fill-in-place procedures are to begin.

Excavate to the top of the tank if necessary. Drain and flush piping contents back to tank. Remove all tank top equipment and piping.

Remove liquids and residues from the tank and clean¹¹

To proceed with fill in place, flowable mortar, clean sand or other fill material approved by the DNR may be used to completely fill the underground tank to 100% of capacity.

Sand is generally available, will flow readily, and is a suitable material if it is clean and free of rocks (which would prevent leveling out in the tank). The sand should be introduced dry. As it nears the top of the tank, the sand can be washed into the tank with NOMINAL amounts of water and puddled causing it to flow to the ends. Use of large amounts of water is prohibited as it will cause the tank to be filled with water before it is filled with sand.

Purge the tank and surrounding area of all vapors, and monitor with a CGI continuously during the procedure. Keep the atmosphere in the tank below 10% of the LEL and/or 6-7% Oxygen (see Purging and Inerting).

¹¹ See American Petroleum Institute publications 2015 and 2219 for safety precautions during removal and fill in place and for vacuum truck operating and safety practices.

Examine the tank for two openings, one at each end of the tank. One opening must be large enough to accept the fill material. Openings at the top of the tank may be too small and/or too few to introduce the inert material and to fill the tank to 100% capacity. The other opening is an observation hole to ensure the tank is filled to capacity. If sufficient openings do not exist, excavate to the top of the tank and make the openings. Use explosion proof, non-sparking tools to increase or enlarge the number of openings (you are still monitoring the atmosphere). Cap or plug all other openings.

Clean the tank according to the procedures explained above (see API #2015, *Cleaning Petroleum Storage Tanks* (see Reference page)).

Fill the tanks using concrete, sand or flowable mortar or other approved material until the inert material flows out of the observation hole.

Submit a closure report to the DNR within 45 days of the close in place. You may obtain extra copies of the closure form through our web site www.iowadnr.gov/ust.

Closure Report Forms

Within 45 days of UST permanent closure, the DNR closure report is due. Owners and operators usually contract with the CGP to complete the DNR's closure report form since they supervised the collection of soil and groundwater samples, submitted them to the lab and received the sample results. The closure report form is included on the following page. The form is also on the UST Section website.

Complete all sections of the closure report form and attach the information in the appendices on page 5 of the closure report form. The closure report covers all the required information needed in order to properly close the UST system. The UST Section will formally respond to the closure report. If the site is an active LUST site, the report will be forwarded to the LUST project manager who will compare the sample results from the closure with the latest Tier 1 or Tier 2 results.

CURRENT SITE CONDITIONS

Description of the removed UST System and Tank Pit (This page may be photocopied if more than 6 tanks were removed)

TANK NUMBER	1	2	3	4	5	6
Date Tank Removed						
Date Piping Removed						
Tank Size (gallons)						
Tank Length						
Tank Diameter						
Tank Age (approximately)						
Tank Contents						
Tank Construction Material						
Leak Detection Method Used During Active Life of Tank						

Number of Remaining Tanks:

Will new USTs be installed at site? Yes No

If No, and no tanks remain, what is planned future use of site?

EXCAVATION (TANK PIT) CONDITION

Surface Staining (Yes/No)						
Excavation Depth						
Excavation Length						
Excavation Width						
Free Product (Yes/No)						
Notable Odors (Yes/No)						
Soil Discoloration (Yes/No)						
Water in Tank Pit (Yes/No)						
Depth to Water						
Sheen on Water (Yes/No)						
Composition of Backfill Material						
Composition of Native Soil						

EXTERIOR TANK CONDITION

Excellent/Good/Poor

(X ALL THAT APPLY)

General Corrosion	<input type="checkbox"/>	<input type="checkbox"/>	<input type="checkbox"/>	<input type="checkbox"/>	<input type="checkbox"/>	<input type="checkbox"/>
Random Pitting	<input type="checkbox"/>	<input type="checkbox"/>	<input type="checkbox"/>	<input type="checkbox"/>	<input type="checkbox"/>	<input type="checkbox"/>
Perforations	<input type="checkbox"/>	<input type="checkbox"/>	<input type="checkbox"/>	<input type="checkbox"/>	<input type="checkbox"/>	<input type="checkbox"/>
Location of perforations on tank	<input type="checkbox"/>	<input type="checkbox"/>	<input type="checkbox"/>	<input type="checkbox"/>	<input type="checkbox"/>	<input type="checkbox"/>
Stress-Corrosion Cracking	<input type="checkbox"/>	<input type="checkbox"/>	<input type="checkbox"/>	<input type="checkbox"/>	<input type="checkbox"/>	<input type="checkbox"/>
Possible Leak Locations						

PIPING CONDITION (SEE TANK CONDITION)

Piping Construction Material	
Possible Leak Locations	

Was there an odor or visible staining noticed from any of the soil samples? If so which samples?

Was bedrock present?

Was the backfill returned to the tank pit?

GROUNDWATER ANALYTICAL DATA (UG/L)

Complete the table below with groundwater analytical data for each boring/monitoring well. Attach laboratory analytical results, including completed chain of custody form(s) as Appendix 3.

SAMPLE I.D.	DATE SAMPLED	FIELD SCREENING	BENZENE	TOLUENE	ETHYLBENZENE	XYLENES	TEH-DIESEL	TEH-WASTE OIL

Was there a petroleum sheen or odor noticed from any of the groundwater samples? If so, which samples?

Discussion/Recommendations (based on lab results and visual observations):

SUPPORTING DOCUMENTATION AND INFORMATION

ATTACH THESE ITEMS TO THE CLOSURE REPORT

Appendix 1. Dimensioned Site Diagram:

- a. Location of all USTs, piping runs and dispenser islands
- b. Sampling locations/identification that correspond to the laboratory analytical reports
- c. Boring/monitoring well locations
- d. Location of buildings and above ground tanks and piping on the site (include size and contents of ASTs)
- e. Groundwater flow direction (if unknown, estimate and explain how determined)
- f. North arrow
- g. Scale of the diagram in feet (or at least provide distances in feet)
- h. Dimensions of: 1) excavation pit area (NB: overexcavation is limited to one foot of contaminated soils. A soil sample must be collected after overexcavation from the area showing the greatest contamination)
- i. Location of underground utilities within 100 feet of the site (e.g., sanitary sewers, public/private wells, power lines, storm sewers, utility trenches, water lines, pipelines, etc.)

Appendix 2. Soil Boring Logs / Monitoring Well Construction Diagrams

Stratigraphic logs of the boreholes and construction details of the well (see attached log), and disposition of the monitoring well after sampling

Appendix 3. Laboratory Analytical Results

Certified laboratory analytical results for each sample, including completed chain of custody form(s)

Appendix 4. Tank Tags

Remove tanks and return them with closure report

Appendix 5. Tanks and Tank Cleaning

- a. Tank cleaning/disposal (e.g., signed statement from the party who performed the cleaning service indicating the UST was cleaned, and a certificate of disposal from the receiving facility)
- b. Documentation of sludge/wastewater disposal (e.g., signed statements, copies of permits)
- c. Photographs of the cleaning of the tanks

Appendix 6. Soil and Water Disposal

- a) Documentation of the proper disposal of contaminated soil (e.g., landfill disposal receipts, weight tickets)
- b) Documentation of the proper disposal of contaminated pit water, including: signed statement of permission from the POTW prior to disposal;
- c) Documentation of wastewater characterized by the POTW, and
- d) Appropriate documentation that the wastewater was accepted by the POTW

Color Photographs

- a. Photos before excavation
- b. Ends and sides of all tanks
- c. Cleaned interior of tanks
- d. Tank pit floor and sidewalls
- e. Product line and dispenser trenches
- f. Bedrock if exposed
- g. Sealed USTs/product lines that are closed in place
- h. Photos after completion of closure
- i. Descriptions of photos
- j. Disk of color photos



UST Closure Report – Filling In Place

UST REGISTRATION	LUST (IF APPLICABLE)
-------------------------	-----------------------------

Site Name:		
Site Address:	City:	Zip:
Contact Person:	Phone:	

OWNER IDENTIFICATION

Name:	Company:		
Street:	E-mail:		
City:	State:	Zip:	Phone:

IOWA LICENSED REMOVER

Name:	Iowa Licensed Remover No:	Date:
Company:	E-mail:	
Address:	Phone:	
City:	State:	Zip:

CERTIFIED GROUNDWATER PROFESSIONAL (CGP)

Name:	Certification No:	Date:
Company:	E-mail:	
Address:	Phone:	
City:	State:	Zip:

CLOSURE SAMPLE COLLECTOR (IF NOT THE CGP LISTED ABOVE)

Name:	Date:	
Company:	E-mail:	
Address:	Phone:	
City:	State:	Zip:

I certify that I have reviewed this document, appendices and attachments for submittal to the Iowa Department of Natural Resources. To the best of my knowledge, the information provided is true, accurate and complete.

Signature – OWNER	Date	Signature – LICENSED REMOVER	Date
Signature – CGP	Date	Date Submitted	

CURRENT SITE CONDITIONS						
Description of the UST System and Site Conditions <i>(This page may be photocopied if more than 6 tanks were removed)</i>						
TANK NUMBER	1	2	3	4	5	6
Tank Size						
Number of Samples Collected for Each Tank						
Tank Contents						
Tank Construction Material						
Leak Detection Method Used During Active Life of Tank						
Date Tank Filled in Place						
Inert Material Used to Fill Tank						
Surface Staining? (Yes/No)						
Product Piping Removed? (If "Yes" describe condition of piping, e.g., corrosion, perforations, stress cracks, good, poor, etc., and if any sign of a release was observed)	<input type="checkbox"/> Yes <input type="checkbox"/> No		Length of piping removed (in feet):			
Piping Abandoned in Place?	<input type="checkbox"/> Yes <input type="checkbox"/> No					
Piping Construction Material:						
Number of Active Tanks Remaining:						
Reason for filling in place vs removal:						

TANK CLEANING AND DISPOSAL						
Tank Cleaning Method Used						
Final Disposition of Sludge and Wastewater						
Contractor Responsible for Tank Cleaning/Disposal (Name/Address/Phone)						
Tank Disposal Location						
TANK NUMBER	1	2	3	4	5	6
Quantity of Surplus Product Removed From Tanks (gallons)						
Final Disposition of Surplus Product						

Was there a petroleum sheen or odor noticed from any of the groundwater samples? If so, which samples?

Discussion/Recommendations (based on lab results and visual observations):

SUPPORTING DOCUMENTATION AND INFORMATION

ATTACH THESE ITEMS TO THE CLOSURE REPORT

Appendix 1. Dimensioned Site Diagram:

- a. Location of all USTs, piping runs and dispenser islands
- b. Sampling locations/identification that correspond to the laboratory analytical reports
- c. Boring/monitoring well locations
- d. Location of buildings and above ground tanks and piping on the site (include size and contents of ASTs)
- e. Groundwater flow direction (if unknown, estimate and explain how determined)
- f. North arrow
- g. Scale of the diagram in feet (or at least provide distances in feet)
- h. Location of underground utilities within 100 feet of the site (e.g., sanitary sewers, public/private wells, power lines, storm sewers, utility trenches, water lines, pipelines, etc.)

Appendix 2. Soil Boring Logs / Monitoring Well Construction Diagrams

Stratigraphic logs of the boreholes and construction details of the well (see attached log), and disposition of the monitoring well after sampling

Appendix 3. Laboratory Analytical Results

Certified laboratory analytical results for each sample, including completed chain of custody form(s)

Appendix 4. Tank Tags

Remove tanks and return them with closure report

Appendix 5. Other Documentation. Provide the following:

- a. Tank cleaning/disposal (e.g., signed statement from the party who performed the cleaning service indicating the UST is clean and copies of photographs taken during the closure)
- b. Invoice of solid, inert material used to fill tank in place

Color Photographs

- a. Photos before fill in place
- b. Ends and sides of all tanks
- c. Cleaned interior of tanks
- d. Tank pit floor and sidewalls
- e. Product line and dispenser trenches
- f. Bedrock if exposed
- g. Sealed USTs/product lines
- h. Photos after completion of closure
- i. Descriptions of photos
- j. Disk of color photos

APPENDIX A: Qualifications for Excluding Groundwater Samples for UST Closures

If groundwater is encountered within ten feet (10') below the lowest level of the tank excavation, a groundwater sample is required. If groundwater is not encountered within ten feet (10') below the lowest level of the tank excavation, but sands or highly permeable soils are encountered, or there are other indications of potential for groundwater contamination, a groundwater sample or samples are required (see Section II, Part 2 of this guidance document).

Conditions for Exclusion

If sands or highly permeable soils are not present in a boring located within 20 feet (20') downgradient from the tank excavation and groundwater is not encountered within ten feet (10') below the lowest level of the tank excavation, the certified well contractor's log and the results of a hydraulic conductivity test must be submitted with the closure report to the DNR. The hydraulic conductivity test must be conducted by a person knowledgeable in the performance and interpretation of such testing. The results of the test must indicate a conductivity rate less than 0.3 meter per day in order to exclude the groundwater sample requirement.

A hydraulic conductivity test, using a Guelph permeameter or an equivalent in situ constant head permeameter in a boring which terminates above the water table and ten feet (10') below the lowest level of the tank excavation is acceptable. If laboratory methods are used, collect undisturbed soil samples using a thin-walled tube sampler in accordance with the American Society of Testing and Materials (ASTM) Standard D1587. Samples shall be clearly marked, preserved and transported to the laboratory. The laboratory shall measure hydraulic conductivity using a constant-head permeameter in accordance with ASTM Standard D2434 or a falling-head permeameter in accordance with acceptable methodology.

Definition of Highly Permeable Soils

- 1) Sands and highly permeable soils for the purposes of UST closures are defined as:
 - a. **(CGg)** clean well sorted gravel greater than 0.25 inches in diameter
 - b. **(CGs)** gravel with minor amounts of sand
 - c. **(CGc)** clean sand
 - d. **(CGp)** sand with minor amounts of pebbles or gravel
- 3) Vulnerable bedrock
- 4) Any soils having a hydraulic conductivity rate greater than 0.3 meter per day

APPENDIX B: Encountering Bedrock during Groundwater Sampling for Tank Closure

Certified Well Driller and Groundwater Professional Required

For all tank closures, a groundwater sample is required from the first saturated groundwater zone. The monitoring well or boring must be positioned downgradient, outside of the tank pit, and not farther than 20 feet (20') from the tank pit. If the top of the water table is suspected to be within bedrock or if bedrock is encountered before groundwater during drilling activity, a certified well contractor must conduct the drilling and a certified groundwater professional must conduct the assessment and sampling activity.

Shallow Bedrock Assessment

Before drilling for a groundwater sample, the groundwater professional must determine if there is a potential to encounter bedrock before groundwater. These potential areas include (1) areas where karst features or outcrops exist within one mile of the site and (2) areas with bedrock less than 50 feet from the surface. The purpose of this determination is to prevent drilling through contaminated subsurface areas thereby creating a preferential pathway to a bedrock aquifer.

If bedrock is encountered before groundwater, a Tier 2 SCR must be completed in accordance with the requirements in the Tier 2 SCR guidance document, and special bedrock procedures in Subrule 135.10(3). If the first encountered groundwater is above bedrock but near the bedrock surface, or fluctuates above and below bedrock, the groundwater professional should evaluate the sub-surface geology and aquifer characteristics to determine the potential for creating a preferential pathway. If it is determined the aquifer shows extraordinary variations or inconsistencies in groundwater flow, groundwater elevations across the site, hydraulic conductivities, or total dissolved solid concentrations among monitoring wells, a Tier 2 assessment using special bedrock procedures must be conducted. If the first encountered groundwater is above the bedrock with sufficient separation and aquifer characteristics to establish that it acts as a granular aquifer as provided in 135.10(3)"a", a Tier 1 assessment must be conducted as provided in this guidance.

Field Screening for Contamination

The groundwater professional must first identify the presence of petroleum contamination in the soil (overburden) through the use of field screening methods (e.g., PID, FID) in order to reduce the risk of spreading contamination to the bedrock aquifer and to determine an appropriate drilling method and monitoring well construction technique. If field screening indicates contamination in the overburden, the most contaminated soil should be determined and selected for lab analysis. Owners and operators must report to the department the discovery of a release in accordance with IAC 567--135.6.

When Bedrock Contamination is Suspected

If the use of field screening indicates the presence of contamination in the overburden, the overburden must be isolated from the bedrock by installing a permanent casing before continuing drilling, sealing all the casing string with grout seal and seating the casing in the bedrock. Installation of a grout seal around all of the casing in the overburden and seating the casing in the bedrock should ensure the well will remain free of petroleum contamination. The casing should be set and all equipment removed and cleaned before continuing to drill to water.

The bedrock cuttings should be continuously screened for the presence of contamination. The bedrock boring may be cased or uncased depending on the friability of the bedrock material. After the first saturated groundwater zone is encountered, either a temporary well or permanent well may be installed and a water sample collected for lab analysis.

Contamination in the Overburden with a Confining Unit

While drilling into bedrock, if a substantial confining layer of material (e.g., shale) is encountered before groundwater, drilling should cease. The confining layer should trap groundwater as well as contamination from a release in the UST system. Construct a temporary well above the confining unit to collect a groundwater sample for lab analysis.

No Contamination in the Overburden

When the presence of contamination in the overburden is not identified through field screening or analysis, an uncased groundwater monitoring well may be constructed, and a water sample from the bedrock aquifer may be collected for lab analysis.

USTs Set in Bedrock

If the UST is resting on bedrock, examine the tank pit for petroleum staining. If petroleum staining is present, remove all backfill material. If the base of the tank pit is bedrock, but the sidewalls are not bedrock and staining is present in the UST pit, collect a soil sample from each of the sidewalls (nearest the bedrock surface). Use field screening methods to locate the presence of contamination in the tank pit.

Summary

Before a groundwater monitoring well is constructed in bedrock, a certified groundwater professional must evaluate the subsurface conditions of the UST site. The purpose of the evaluation is to determine the potential for product migration and groundwater contamination. Some of the geologic information necessary for an assessment will be difficult to know in advance. Therefore, a full assessment of the bedrock conditions may not be known until after the drilling is completed. The evaluation should contain the following information:

- 1) Type of bedrock
- 2) The competence of bedrock (if available)
- 3) A description of the potential for karst development at the site (if available)
- 4) The presence or absence of water in the tank pit and the water source
- 5) The depth to groundwater (if available)
- 6) The direction of groundwater flow (based on topography and knowledge of local geology)
- 7) A description of the stratigraphy present in the area, i.e., surficial aquifers vs. deeper aquifers, etc.

Plugging Abandoned Wells

All abandoned wells and borings that access groundwater must be plugged according to 567-Chapter 39. DNR Form 542-1226, Abandoned Water Well Plugging Record, must be completed and submitted to the department. The Abandoned Water Well Plugging Record form 542-1226 is available on the UST Section website www.iowadnr.gov/ust.

APPENDIX C: Exempt Pre 1974 Tanks

AFFIDAVIT

Exempt Pre-'74 Tanks
January 1, 1974 Exclusion

This section must be completed by the owner and notarized:

I, _____, being duly sworn, hereby certify
(please print)
that the following statements and all attached documents are true and accurate to the best of my knowledge.

1) I am the owner of _____ underground storage tanks as defined by Iowa Code Section
455B.471(6) located at the address of: _____ in the
_____ Quarter of Section _____, Township _____, Range _____ East West

- 2) That these tanks were taken out of operation prior to January 1, 1974,
- 3) That these tanks have not contained a regulated substance since January 1, 1974,
- 4) That these tanks do not currently contain an accumulation of a regulated substance, and
- 5) The execution of this instrument is my voluntary act and deed.

Signature of Owner (In Ink)

Date

STATE: _____ COUNTY OF _____ Sworn to and subscribed before me this _____ Day of _____, _____ _____ Notary Public	(Seal) _____ My Commission Expires
--	--

APPENDIX D: Monitoring Records Used in Lieu of Soil & Water Sampling

AFFIDAVIT

Monitoring Records Used In Lieu of Soil & Water Sampling
This section must be completed by the owner and notarized:

I, _____, being duly sworn, hereby certify
(please print)
that the following statements and all attached documents are true and accurate to the best of my knowledge.

- 1) Approved leak detection as defined by Iowa Code Section 455B.135(5), is present on the
underground storage tanks located the address of: _____ in the
_____ Quarter of Section _____, Township _____, Range _____ [] East [] West
2) That the leak detection has been in proper operating condition since _____ (date)
3) That the leak detection has been in operation since _____ (date)
4) That there has been no indication of a release at this site, and
5) The execution of this instrument is my voluntary act and deed.

Signature of Owner (In Ink)

Date

STATE: _____
COUNTY OF _____
Sworn to and subscribed before me this _____
Day of _____, _____
Notary Public
(S Seal)
My Commission Expires _____

APPENDIX E: Explosive Limits of Gases

Explosive Limits of Gases

Fuel Gas	“Lower Explosive or Flammable Limit” (LEL/LFL) (%)	“Upper Explosive or Flammable Limit” (UEL/UFL) (%)
Acetaldehyde	4	60
Acetone	2.6	12.8
Acetylene	2.5	81
Ammonia	15	28
Arsine	5.1	78
Benzene	1.35	6.65
n-Butane	1.86	8.41
iso-Butane	1.80	8.44
isobutene	1.8	9.0
Butylene	1.98	9.65
Carbon Disulfide	1.3	50
Carbon Monoxide	12	75
Cyclohexane	1.3	8
Cyclopropane	2.4	10.4
Diesel Fuel	1.3	6
Diethyl Ether	1.9	36
Ethane	3	12.4
Ethylene	2.75	28.6
Ethyl Alcohol	3.3	19
Ethyl Chloride	3.8	15.4
Fuel Oil No.1	0.7	5
Fuel Oil No. 6	1	5
Hydrogen	4	75

Fuel Gas	“Lower Explosive or Flammable Limit” (LEL/LFL) (%)	“Upper Explosive or Flammable Limit” (UEL/UFL) (%)
Isobutane	1.8	9.6
Isopropyl Alcohol	2	12
Gasoline	1.4	7.6
Kerosene	0.7	5
Methane	5	15
Methyl Alcohol	6.7	36
Methyl Chloride	10.7	17.4
Methyl Ethyl Ketone	1.8	10
Naphthalene	0.9	5.9
n-Heptane	1.0	6.0
n-Hexane	1.25	7.0
n-Pentene	1.65	7.7
Neopentane	1.38	7.22
Neohexane	1.19	7.58
n-Octane	0.95	3.20
iso-Octane	0.79	5.94
n-Pentane	1.4	7.8
iso-Pentane	1.32	9.16
Propane	2.1	10.1
Propylene	2.0	11.1
Silane	1.5	98
Styrene	1.1	6.1
Toluene	1.27	6.75
Triptane	1.08	6.69
p-Xylene	1.0	6.0

Note! The limits indicated are for gas and air at 68 °F (20 °C) and atmospheric pressure.¹²

¹² The Engineering ToolBox Website: http://www.engineeringtoolbox.com/explosive-concentration-limits-d_423.html.

APPENDIX F: Reporting Petroleum Releases from UST Systems

REPORTING PETROLEUM RELEASES FROM UST SYSTEMS

Reporting Promptly Protects the Public and the Environment

I. Reporting Requirements for Releases

Iowa law requires owners and operators of UST systems to report a confirmed or suspected release of “regulated substances”, which includes petroleum, to the DNR within 24 hours or within 6 hours if a hazardous condition exists [567 Iowa Administrative Code (IAC)—135.6 & Iowa Code section 455B.386].¹³

This guidance is intended to help owners and operators (and others) determine what is a suspected release versus a confirmed release, and under what conditions a release becomes a “hazardous condition” triggering the 6-hour reporting requirement to the DNR and the local enforcement authority.

II. What is a Suspected Release and What are the Reporting Requirements?

Even though there is no obvious visual or olfactory evidence of a release- such as stained soils or a strong hydrocarbon odor- the presence of other indicators may suggest a release has occurred from the UST system. Below are examples of conditions qualifying as a “suspected release”:

1. Vapor or product is detected in vapor monitoring or groundwater monitoring wells used for leak detection.
2. Inventory control discrepancies indicate that a release may have occurred (a gain or loss of product greater than 130 gallons + 1% of throughput).
3. Alarms from automatic tank gauging (ATG) systems, interstitial monitors, sump sensors, automatic line leak detector, etc. indicate that a release may have occurred.
4. Statistical inventory reconciliation (SIR) results indicate either a *Fail* or two consecutive *Inconclusive*.
5. Unexplained loss of product.
6. Unexplained presence of water in the tank or sump.
7. Product dispensing equipment does not dispense product or dispenses product at a greatly reduced rate.
8. Internal tank (periodic) inspection results reveal perforations, corrosion holes, weld failures, or other similar defects.

III. Suspected Release Investigation

¹³ Department Rules read as follows: 567—135.6(455B) Release reporting, investigation, and confirmation.

135.6(1) Reporting of suspected releases. Owners and operators of UST systems must report to the department within 24 hours, or within 6 hours in accordance with 567—Chapter 131 if a hazardous condition exists as defined in 567—131.1(455B), or another reasonable time period specified by the department, and follow the procedures in 135.8(1) for any of the following conditions:

- a. The discovery by owners and operators or others of released regulated substances at the UST site or in the surrounding area (such as the presence of free product or vapors in soils, basements, sewer and utility lines, and nearby surface water);
- b. Unusual operating conditions observed by owners and operators (such as the erratic behavior of product dispensing equipment, the sudden loss of product from the UST system, or an unexplained presence of water in the tank), unless system equipment is found to be defective but not leaking, and is immediately repaired or replaced; and
- c. Monitoring results from a release detection method required under 135.5(2) and 135.5(3) that indicate a release may have occurred unless:

- (1) The monitoring device is found to be defective, and is immediately repaired, recalibrated or replaced, and additional monitoring does not confirm the initial result; or
- (2) In the case of inventory control, a second month of data does not confirm the initial result.

Owners and operators must immediately investigate and confirm suspected releases. Make sure the monitoring device that declared a release is not defective and giving false indications of a release. If it is defective, get it recalibrated, repaired or replaced immediately and make sure subsequent monitoring shows no release. Your petroleum equipment service company is able to help you diagnose whether there is a problem with your monitoring equipment and whether the suspected release can be confirmed.

If the monitoring equipment is found to be operating properly, the suspected release or confirmed release must be reported to the DNR by phone or fax within 24 hours. Make sure to contact Emergency Response if the release creates a hazardous condition (see part VII. below). You should also contact your UST insurance company to inform them you have a suspected or confirmed release.

Shut down the product line if you suspect a release from the product piping (slow flow, failed test results, positive shutoff, alarm, etc.). Shut down the submersible pump and empty the tank if a sudden loss of product occurs from the tank or if test results indicate a "Fail."

If there is a suspected release that cannot be explained due to defective monitoring equipment or the source of the release is unknown or uncertain, regulations require you to test your UST system to confirm if a leak has occurred. You must proceed with system tightness testing, which can detect a release at least as small as 0.1 gph in the tanks and/or product lines. If the precision test results are "Fail," a site investigation may be necessary. The DNR will issue a letter requiring a site check. You must repair or replace defective equipment if the test indicates a leak has occurred in the system. Submit documentation of the repair or replacement to the DNR (e.g., invoice, 148 form, and installation checklist if necessary).

IV. What is a Confirmed Release and What are the Reporting Requirements?

A release can be confirmed when based on visual and olfactory observations it is evident that petroleum or other regulated substances have breached the UST system or come in contact with the surface material (concrete/asphalt), backfill material, soil, groundwater or surface water or the system monitoring has confirmed a leak in the UST system that cannot be observed. The owner or operator must report the release to the DNR within 24 hours or six hours if a hazardous condition exists (see part VII below). Environmental evidence of a confirmed release includes:

1. Soil or groundwater sample analytical results for any petroleum constituent exceed the DNR's action levels [567—135.14].
2. There is a spill or overflow from the UST system.
3. There is an affected receptor (e.g., petroleum discovered in a utility trench, which can be attributed to the UST facility or the UST facility cannot be ruled out as a source).
4. Drinking water supplies are contaminated, which can be attributed to the UST facility or the UST facility cannot be ruled out as a source.
5. Vapors are observed in buildings or structures which can be attributed to the UST facility or the UST facility cannot be ruled out as a source.
6. Free product is observed in the environment or in monitoring well used for release detection or LUST monitoring.
7. Stained soil is observed.
8. A sheen is observed on surface water

V. Exceptions:

An aboveground release of petroleum from an UST facility does not need to be reported to DNR if it is less than 25 gallons, does not reach soil, groundwater or surface water, and is cleaned up within 24 hours and the facility retains records of the incident.

An overflow caused by a transporter filling an UST does not need to be reported to DNR if the spill is contained in the spill bucket of the UST and does not reach the backfill. A spill (e.g., a customer who overfills the vehicle's gas tank) of less than 25 gallons does not need to be reported if it is cleaned up within 24 hours and does not reach soil, groundwater or surface water. If a spill less than 25 gallons cannot be cleaned up within 24 hours, it must be reported.

VI. Confirmed Release Investigation

After reporting the confirmed release, take immediate action to prevent the spread of the release and danger to the public (e.g., fire, vapor and explosion hazards). If the public is in danger from a spill or overflow, immediately contact DNR's Emergency Response and the local enforcement authority. Shut down the pump for the suspected tank or product line. Investigate for free product in sumps and in under dispenser containment (UDC). Be mindful that you are investigating for the presence of flammable or combustible liquids. Avoid contact with the substance, and keep any ignition sources out of the area.

If the source of the release is the tank, contact your petroleum equipment service provider to have the tank emptied and to further investigate the problem. Upon receipt of the Release Report Form, the DNR will complete a Preliminary Leaking Underground Storage Tank (LUST) Report, the information will be entered into the database, and the owner/operator will receive a letter in the mail requiring a Risk Based Corrective Action (RBCA) assessment.

VII. What is a Hazardous Condition Requiring Reporting within 6 Hours?

A hazardous condition is defined in 567 IAC—131.1 and means any situation where a suspected or actual release of a hazardous substance, such as petroleum, places the health and safety of the public or the environment in danger.¹⁴

An example of a hazardous condition is product floating on the groundwater in the tank pit or in a monitoring well; a sheen of product on a lake, in a stream or a river; product discovered in a sump, a monitoring well, or in the UDC; more than 25 gallons of product overflowing or spilling onto the ground; vapors or product present in a building, sewer or utility line. In any of these situations, imminent or potential danger exists to the public or the environment and must be reported immediately.

An overflow that occurs during product delivery and which is not contained by the spill bucket must be reported immediately by the transporter (See 567 IAC—135.6(4) and 567 IAC—131.1). A release of a hazardous substance must be reported within 6 hours.

¹⁴ "Hazardous condition" means any situation involving the actual, imminent or probable spillage, leakage, or release of a hazardous substance onto the land, into a water of the state or into the atmosphere which, because of the quantity, strength and toxicity of the hazardous substance, its mobility in the environment and its persistence, creates an immediate or potential danger to the public health or safety or to the environment.

Releases of petroleum from non-regulated sources such as heating oil tanks, aboveground storage tanks, and farm and residential tanks must also be reported to DNR within 6 hours if a hazardous condition exists. To report a release, contact Emergency Response, the field office in the region where the release occurred, and the UST Section at the DNR central office.

1. Emergency Response: (24 hour phone) 515.725.8694 or fax 515.281.7229
 - a. <http://www.iowadnr.gov/Environmental-Protection/Land-Quality/Emergency-Planning-EPCRA/Spill-Reporting>
2. DNR Field Offices: (See table below.)
 - a. <http://www.iowadnr.gov/fieldoffice>

Field Office	Phone	Fax	Field Office	Phone	Fax
1-Manchester	563.927.2640	563.927.2075	4-Atlantic	712.243.1934	712.243.6251
2-Mason City	641.424.4073	641.424.9342	5-Des Moines/ Windsor Heights	515.725.0268	515.725.0218
3-Spencer	712.262.4177	712.262.2901	6-Washington	319.653.2135	319.653.2856

3. UST Central Office: (work hours phone) 515.725.8200 or fax 515.725.8202
4. Use the Release Report Form to fax within 24 hours or 6 hours:
<http://www.iowadnr.gov/Environmental-Protection/Land-Quality/Underground-Storage-Tanks/UST-Forms>

VIII. It's Good Business: Don't Make a Release More Expensive or Complicated

Reporting suspected and confirmed releases promptly as required and as soon as it is known not only protects the public and the environment, but can save the owner/operator money and lower cleanup costs. When a release is reported in a timely manner and the release investigation is begun quickly, further spread of the contamination can be prevented.



UST RELEASE NOTIFICATION FORM

(Completed by the UST Professional and Submitted to DNR UST Section and Owner/Operator)

A suspected or confirmed release has been identified at your property by your UST professional. Pursuant to Iowa Code section 455B.474 and 567 Iowa Administrative Code (I.A.C.) 135.6(1), **UST system owners and operators** are required by law to report suspected or confirmed releases to the Iowa Department of Natural Resources within 24 hours of discovery, or 6 hours if a hazardous condition exists, unless an exception applies. Please see the Department's Release Guidance at <http://www.iowadnr.gov/InsideDNR/RegulatoryLand/UndergroundStorageTanks/USTForms.aspx> for more information, including a Release Reporting Form.

If a confirmed release has been identified at your property, your UST Professional is required by 567 I.A.C. 134.22 to submit a copy of this form to the Department within seven days of discovery. This secondary submission does NOT excuse the owner/operator from making the initial reporting as discussed above and in the release guidance. Failure to directly report a suspected or confirmed release may result in the Department taking enforcement action against the owner/operator, to include the assessment of a monetary penalty.

For suspected and confirmed releases, notify the Iowa Department of Natural Resources at the number listed at the bottom of this form. For hazardous conditions, notify the Department and your local law enforcement.

SITE INFORMATION			
Site Name:			UST No:
Site Address:			
City:			ZIP Code:
NOTIFIED PARTY			
Owner/Operator Name:			
Notification form sent to (address):			
City:	State:	ZIP Code:	
Owner/Operator Phone Number:			
Date Notified Orally:			Date Notified by Mail:
Owner/Operator Signature:			
UST PROFESSIONAL			
Iowa UST Professional Name:			
Company:			Phone Number:
Company Address:			
City:	State:	ZIP Code:	
Iowa UST Professional Signature:			
RELEASE			
<input type="checkbox"/> Confirmed Release	<input type="checkbox"/> Suspected Release	Date Discovered:	
Leak Status:	<input type="checkbox"/> Continuing	<input type="checkbox"/> Stopped	<input type="checkbox"/> Unknown
Description:			
Recommended Action:			



UST Release Report

UST # _____

LUST # _____

RELEASE REPORT INFORMATION

RELEASE REPORTED BY:		
COMPANY:	PHONE:	
ADDRESS:		
CITY:	STATE:	ZIP:
DATE RELEASE DISCOVERED:	DATE RELEASE REPORTED:	

SITE INFORMATION

SITE NAME:		
SITE ADDRESS:		
CITY:	COUNTY:	ZIP:

FACILITY OWNER INFORMATION

OWNER/OPERATOR NAME:		
COMPANY NAME:		
OWNER/OPERATOR STREET ADDRESS:		
CITY:	STATE:	ZIP:
OWNER/OPERATOR PHONE NUMBER:		

PROPERTY OWNER INFORMATION *(if different than facility owner):*

PROPERTY OWNER NAME:		
COMPANY NAME:		
PROPERTY OWNER STREET ADDRESS:		
CITY:	STATE:	ZIP:
PROPERTY OWNER PHONE NUMBER:		

RELEASE INFORMATION

SUBSTANCE RELEASED:

- E-85
- HEATING OIL
- GASOLINE
- DIESEL
- WASTE OIL
- BIODIESEL
- KEROSENE
- OTHER: _____

ESTIMATED AMOUNT OF SUBSTANCE RELEASED: _____

HOW WAS RELEASE DISCOVERED:

- UST Closure
- Field Office Visit
- Environmental Audit
- UST Inspection
- Vapors Detected
- Sump Sensor
- Line Leak Detector
- Citizen Complaint
- Service Visit
- Line Tightness Test
- Tank Tightness Test
- Site Check
- Cathodic Protection Testing
- Inside Secondary Containment Sump
- Tank Leak Detector (Indicate Method): _____
- Other (Specify): _____

CAUSE OF RELEASE:

- Flex Connector
- Install Problem
- Overfill
- Spill of Customer
- Physical/Mechanical Problem
- Dispenser Leak
- Tank Leak
- Line Leak
- Leak Detector
- Corrosion
- Unknown
- Other (Specify): _____

SOURCE OF RELEASE:

- Tank
- Piping
- Submersible Turbine Pump
- Delivery Problem
- Dispenser
- Other (Specify): _____

PRODUCT DELIVERY:

- Pressurized
- Suction
- Safer Suction

PIPING MATERIAL:

- Steel
- Fiberglass
- Flex

BRIEF DESCRIPTION OF THE RELEASE:

Briefly describe the release (including but not limited to where release was discovered, amount of free product present, location of free product). Provide/attach a sketch of the location of the release (specific or general location).

MEDIA AFFECTED BY RELEASE:

- Surface Soil
- Subsurface Soil
- Drainage Ditch
- Public Water Supply Well
- Storm Sewer
- Groundwater
- Sanitary Sewer
- Non-Potable Water Supply Well
- Vapors Inside Offsite Commercial Building
- Vapors Inside Residence
- Domestic Water Supply Well
- Vapors Inside Onsite Commercial Building
- Creek/Stream/River/Lake
- _____

RESULTS OF EXPOSURE ASSESSMENT (if immediately available):

How many private drinking water wells are located within 1,000 feet of the site? _____

How many public water supply wells are located within 1,000 feet of the site? _____

Have any drinking water supply wells been affected by contamination from this release?

Yes No

Is there imminent threat of contamination to any drinking water wells?

Yes No

Have vapors or contaminated groundwater posed a threat to the public?

Yes No

Are any underground utilities affected or imminently threatened by the release?

Yes No

Have surface waters been affected by the release?

Yes No

Is there an imminent threat of contamination to surface waters?

Yes No

What is the type of surrounding population? (*Commercial, Residential, Industrial*) _____

~ATTACH OTHER COMMENTS AS NECESSARY~

REPORT RELEASES TO IOWA DNR CENTRAL OFFICE

EMERGENCY RESPONSE

Phone: 515/725-8694

Fax : 515/281-7229

DNR – UST SECTION

Phone: 515/725-8200

Fax: 515/725-8202

Overnight Mailing Address: DNR UST Section, Wallace State Office Bldg., 502 E 9TH ST, Des Moines, IA 50319-0034

REPORT RELEASES TO APPROPRIATE DNR FIELD OFFICE

Field Office	Phone	Fax	Field Office	Phone	Fax
1-Manchester	563.927.2640	563.927.2075	4-Atlantic	712.243.1934	712.243.6251
2-Mason City	641.424.4073	641.424.9342	5- Des Moines/ Windsor Heights	515.725.0268	515.725.0218
3-Spencer	712.262.4177	712.262.2901	6-Washington	319.653.2135	319.653.2856