

# TECHNICAL GUIDE

2013

UNINTERRUPTIBLE POWER SUPPLY

# UPS



THE GLOBAL SPECIALIST  
IN ELECTRICAL AND DIGITAL BUILDING INFRASTRUCTURES





# A guide to choosing your UPS

In general the diffusion of UPS systems derives from an increasingly greater dependence on electrical energy and the need to protect sophisticated equipment, data and processes that are critical for companies. Power electronics is involved and focused to the design and development of static UPS systems with increasingly higher performance levels that allow for adequate energy savings and a lower environmental impact.

## POWER PROBLEMS

Today there is an increasingly pressing need for a continuous, quality power supply. Indeed the devices to power up have an increasingly key, critical role for businesses, for people's safety, for data storage and processing and for communications. After all, these functions are carried out by sophisticated and sensitive devices that may be affected by the disturbance coming from the mains power supply. There are various types of electrical events that constantly endanger electronic equipment, as there are various effects on the availability of the loads (for instance computer systems):

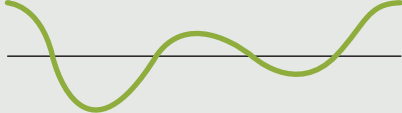

DISTURBANCE	DESCRIPTION	EFFECTS
 <p><b>Brown-out</b></p>	<p>Brief drop in voltage levels. This is the most common disturbance (even 87%) due to the power supply and is caused by the activation of electric devices such as motors, compressors, lifts and freight lifts.</p>	<p>Reduction of the power required by a computer to be able to operate correctly, which causes the keyboard to stop working or unexpected system crashes, resulting in loss and damage of the data being processed.</p>
 <p><b>Power failure</b></p>	<p>A power failure means that there is no power supply at all. It can be due to an excessive demand of electrical energy, storms, ice on the power lines, road accidents, excavations, earthquakes, etc.</p>	<p>The effects that a loss of data may involve include an interruption of communications, no lighting, stopped production lines, an interruption of business activities, hazards for people, etc.</p>

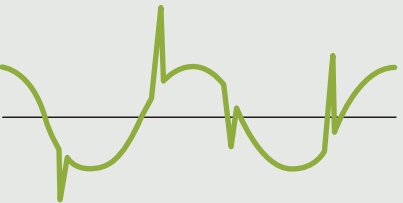
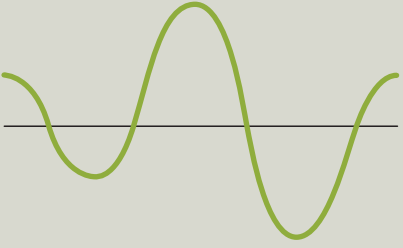
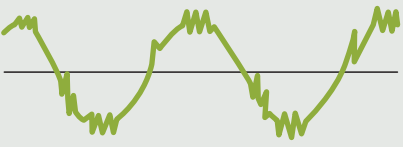
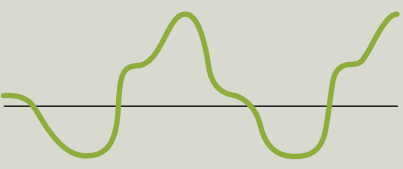
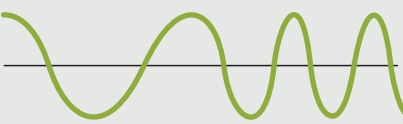
DISTURBANCE	DESCRIPTION	EFFECTS
 <p data-bbox="284 958 344 987"><b>Spike</b></p>	<p data-bbox="544 730 962 875">A spike, or voltage transient, is a sudden surge in voltage. Spikes are generally caused by lightning and can also occur when the mains supply is restored after a power failure.</p>	<p data-bbox="994 730 1362 875">It may also affect electronic devices via the mains supply, serial lines or telephone lines and damage or completely destroy components and cause a permanent loss of data.</p>
 <p data-bbox="252 1256 376 1285"><b>Overvoltage</b></p>	<p data-bbox="544 1010 962 1182">This is a short voltage increase, typically lasting 1/120 of a second. Overvoltage may be caused by very powerful electric motors, such as air-conditioning systems. When these turn off, the excess voltage is dissipated on the electric line.</p>	<p data-bbox="994 1010 1401 1240">Computers and other highly sensitive electric devices require variable voltage within a certain tolerance field. Any voltage value greater than the peak value or effective voltage levels (this can be considered as the average voltage) stresses delicate components and causes premature failure.</p>
 <p data-bbox="236 1529 392 1559"><b>EMI / RFI noise</b></p>	<p data-bbox="544 1301 946 1536">The noise due to electromagnetic interference and radio interference changes the sinusoid generated by the mains supply. It is generated by various factors and phenomena, including lightning, load switching, generators, radio transmitters and industrial equipment.</p>	<p data-bbox="994 1301 1369 1473">The noise may be intermittent or constant and introduces transients, errors and problems in the computer data or in telecommunications. It can also lead to malfunctions in various electrical devices.</p>
 <p data-bbox="148 1809 480 1839"><b>Parasitic and harmonic currents</b></p>	<p data-bbox="544 1583 882 1727">Generated by atmospheric disturbances or changes, load variations, current generators, electromagnetic emissions and industrial systems.</p>	<p data-bbox="994 1583 1401 1727">These disturbances cause errors in the execution of software programs, early deterioration of computers and the data they contain, malfunctions in various types of electric devices.</p>
 <p data-bbox="204 2085 424 2114"><b>Frequency variations</b></p>	<p data-bbox="544 1865 914 1917">They generally occur in the energy produced by power-supply units.</p>	<p data-bbox="994 1865 1401 2033">These variations cause errors in the execution of calculations, interpretation issues related to magnetic supports (discs, tapes, etc.), various kinds of problems associated with electromechanical applications.</p>

# A guide to choosing your UPS (continued)

## UPS TECHNOLOGIES AND EN62040-3 CLASSIFICATION

There are various types of static UPS systems on the market, such as: Off-Line, Line-Interactive, On-Line, Double Conversion, Digital On-Line, In-Line, etc. Most of these names are predominantly associated with marketing needs and decisions rather than the technology employed. In general there are three types of systems:

### 1 OFF-LINE

When the mains supply is on, the output is identical to the input. The UPS attends only when there is no input voltage and powers the load using the inverter, which in turn is powered by the batteries.

### 2 LINE-INTERACTIVE

When the mains supply is on, the input and output are separated by a filtering and stabilisation circuit (AVR: Automatic Voltage Regulator), but some of the disturbances and waveform variations that may be at the input may be found at the output.

As in Off-line systems, when there is a power failure, the output is connected to the inverter, which in turn is powered by the batteries.

### 3 ON-LINE DOUBLE CONVERSION

The input is first rectified and then re-converted into alternating current with an inverter.

This way the output voltage waveform is totally independent from the input. All potential mains disturbances are eliminated and there is no transient time switching from the mains to the battery, as the output is always powered by the inverter.

In the event of overloads or other eventual problems, this type of UPS has an automatic Bypass that ensures the load is powered by switching it directly at the input.

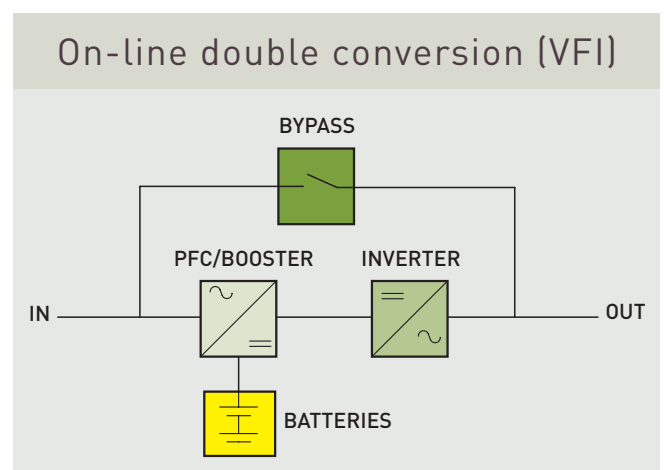
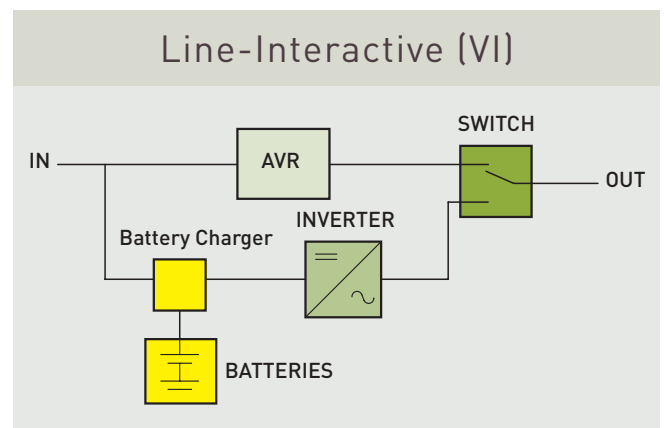
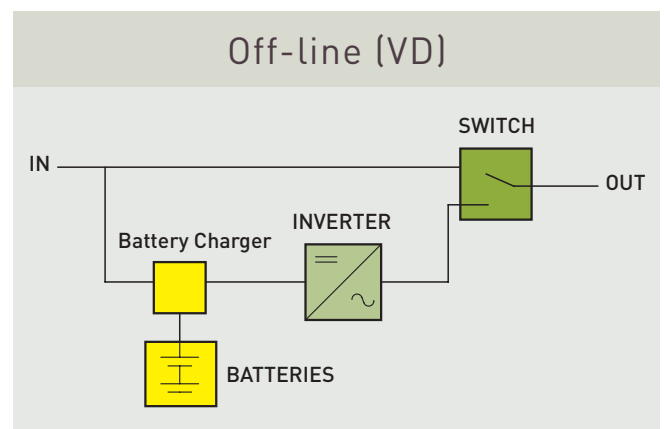

To identify the best-suited UPS for your needs, it is important to carefully examine the features of the application to be protected.

Every UPS offers specific benefits depending on the application for which it is designed.

**It is not enough to consider only the power absorbed by the load!**

The fact that a UPS has enough power to supply the effective load does not ensure it is an adequate choice.

The EN 62040-3 standard defines the classification of the UPS based on its performance.

**EN 62040-3 CLASSIFICATION**

XXX	YY	ZZZ
<b>Output dependence from the Input</b>	<b>Output waveform</b>	<b>Output dynamic performance</b>

The first part of the classification (XXX) defines the type of UPS:

- **VFI** (Voltage and Frequency Independent): this UPS has an output that is independent from supply voltage variations (mains) and frequency variations are controlled within the limits required by the IEC EN 61000-2-2 standard.
- **VFD** (Voltage and Frequency Dependent): this UPS has an output that depends on the supply voltage variation (mains) and frequency variations.
- **VI** (Voltage Independent): in this type of UPS the voltage supply variations are stabilised by electronic/passive regulating devices within the normal operating limits.

The second part of the classification code (YY) defines the output waveform during normal operation or battery-powered operation:

- **SS**: sinusoidal (THDu < 8%),
- **XX**: sinusoidal with linear load, non-sinusoidal with distorting load (THDu > 8%),
- **YY**: non-sinusoidal.

The third part of the classification code (ZZZ) defines the dynamic performance of the output voltage in relation to the load variations occurring in three different conditions:

- **111** variation of the operating modes (normal and battery-based),
- **112** insertion of the step-based linear load in normal or battery-based mode,
- **113** insertion of the step-based non-linear load in normal or battery-based mode.

**EN 62040-3 CLASSIFICATION**

VFI	SS	111
VI	XX	112
VFD	YY	113

**The UPS systems with the best performance are classified as: VFI SS 111**



# A guide to choosing your UPS (continued)

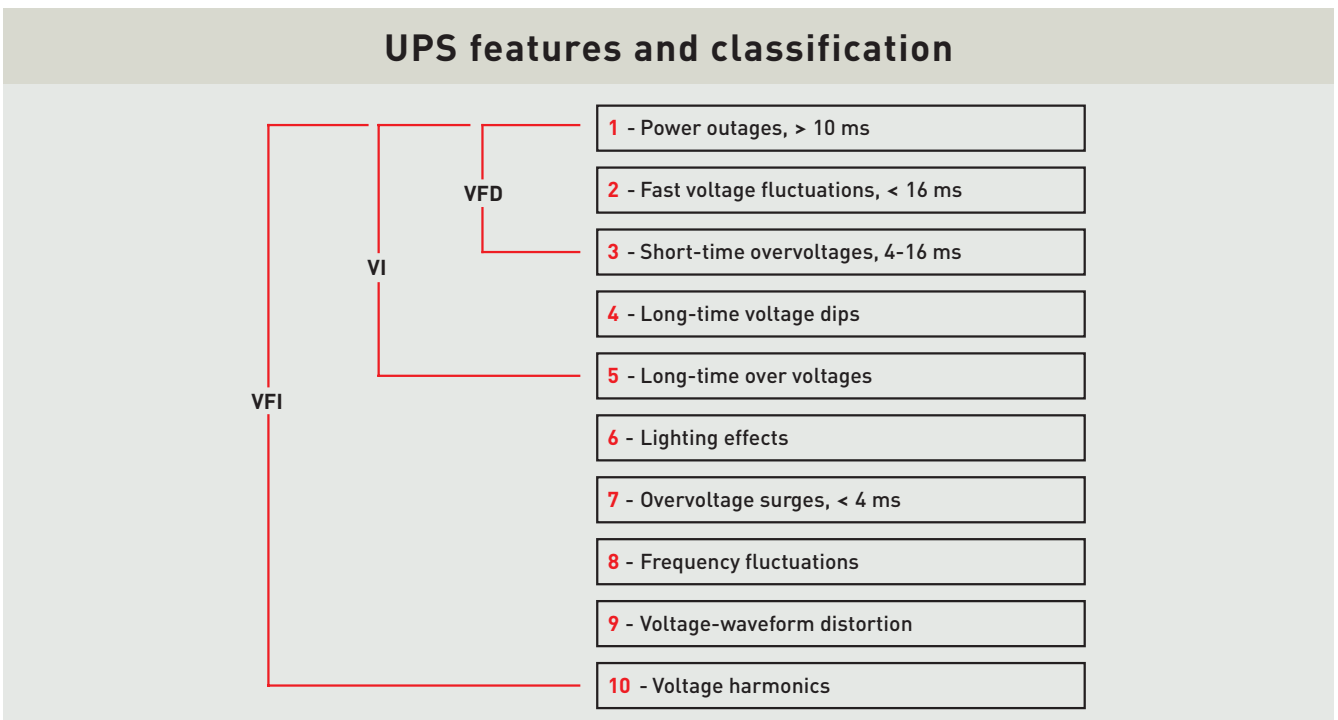
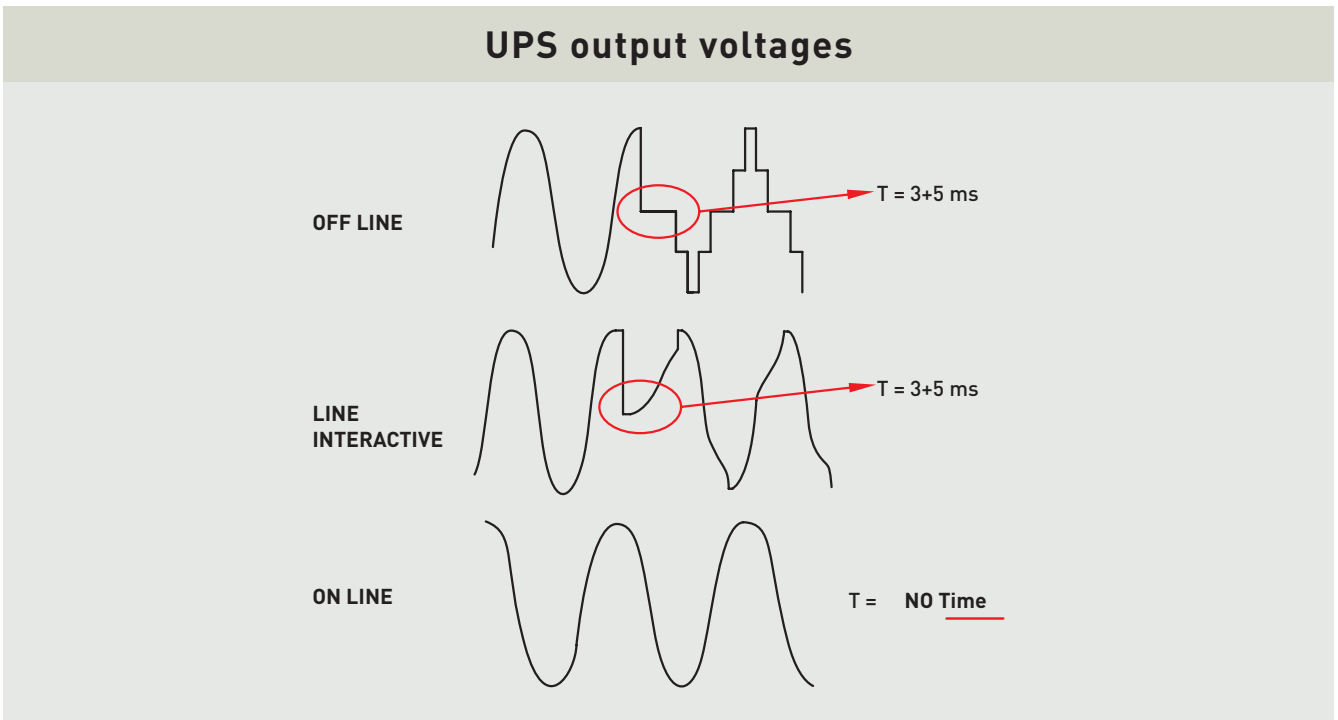

## CHOOSING THE UPS

To choose the correct UPS size, it is necessary to know the following parameters:

- Active and reactive power: this is the UPS' maximum power output expressed in VA.
- ACTIVE power: this is the UPS' maximum power output expressed in W.
- Power Factor (PF): this is the ratio between active and active and reactive power.
- Back-up Time: this is the maximum amount of time for which the UPS can supply energy without mains.
- Power supply characteristics: these are the number of phases and the voltage and frequency values of the power supply line.
- Output power supply characteristics: these are the number of phases and the voltage and frequency values of the UPS output line.

Clearly the input parameters must be compatible with the mains and the output parameters must be compatible with the loads to be powered and protected.



Modular Rack UPS up to 5kVA.



Conventional 2.5kVA single-cabinet UPS.

# A guide to choosing your UPS (continued)

## TYPES OF LOAD (ITIC CURVE)

As for the discrepancies from acceptable nominal values, one of the few clear and internationally acknowledged notes regarding the power supply of electronic devices (namely computer-based equipment) is the ITIC (Information Technology Industry Council) curve. This represents the updated version of the CBEMA (Computer Business Electronic Manufacturer's Association) note, also implemented in the ANSI/IEEE Standard 446-1995: "IEEE Recommended practice for emergency and stand-by power for industrial and commercial applications". The ITIC immunity curve (formerly known as the CBEMA curve) was created with an exclusive reference to Information Technology Equipment (ITE), i.e. basically PCs and similar products, and is based on a simple assessment on the width (higher or lower

than the nominal voltage) and the duration of the disturbance of the power supply voltage. These curves indicate the percentage voltage variations in relation to the nominal value (230V) that are accepted by the devices powered in relation to the duration of these variations. In the figure, the white area represents all the situations in which the device is not affected by the voltage variation. Instead the coloured areas represent situations where they may lead to malfunctions or even failures. Simply, it is evident that the greater the voltage variation the shorter the time the electronic devices can tolerate it without being affected.

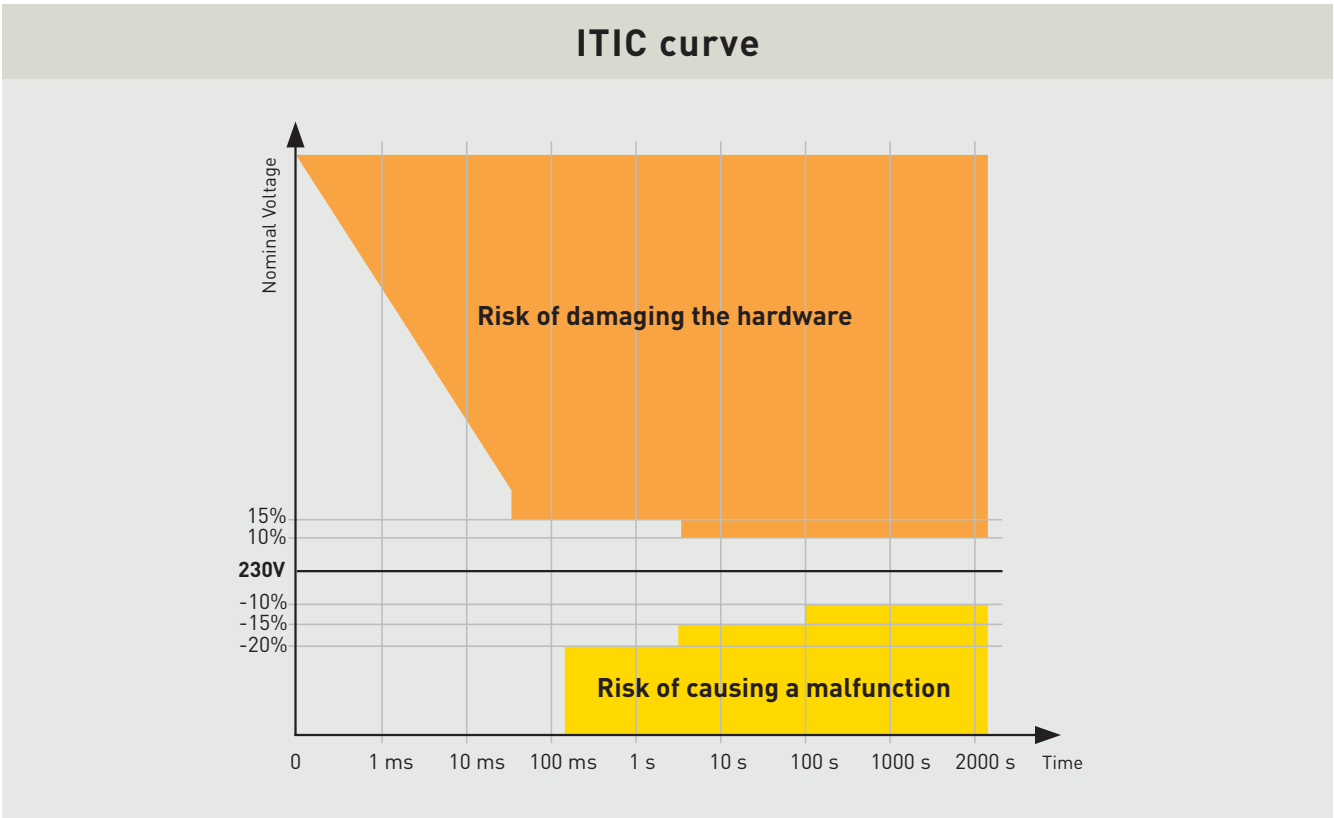



## POSSIBLE APPLICATIONS FOR THE VARIOUS TYPES OF UPS SYSTEMS

By combining the operating features of the UPS systems and knowing the features of the loads to be powered, it is possible to list and group the possible compatible applications for each type of UPS.

### Off-Line

- PC Home
- Internet work stations
- Telephone switchboards
- Tills
- POS terminals
- Fax machines
- Small groups of emergency lights
- Industrial and domestic automation

### Line-Interactive

- Corporate computer networks
- Security systems
- Emergency systems
- Lighting systems
- Domestic and industrial automation

### On-Line Double Conversion

- Corporate IT network.
- Telecommunications.
- Electromedical sector.
- Industrial automation.
- Emergency systems.
- Protection of dedicated lines.
- Critical industrial/civil applications.
- Upstream of power-supply units.
- Any other possible application

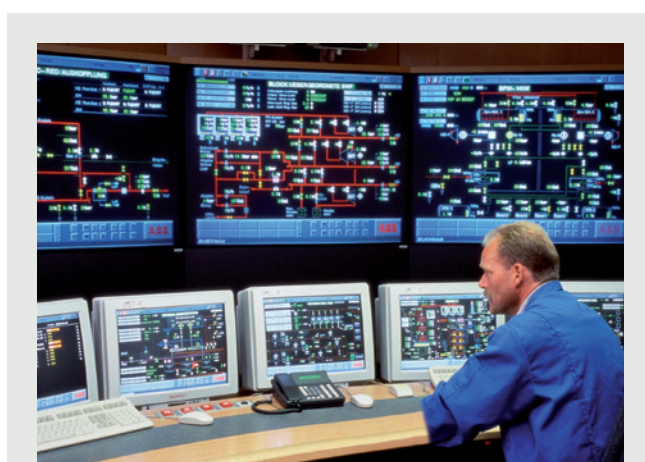

# A guide to choosing your UPS (continued)

## BATTERIES

Batteries are key for the UPS system: they ensure power supply continuity by providing energy to the inverter (for the necessary time) during a power failure. It is therefore essential to have them always connected, operational and charged. Batteries typically used in UPS systems are Sealed Lead Acid batteries (SLA) and Valve Regulated Lead Acid batteries (VRLA).

This type of battery is hermetically sealed, does not require any maintenance and is based on internal gas recombination. As well as ensuring a greater operating life, this feature allows to install the UPS also in areas usually occupied by people. This type of battery needs very little ventilation (which can be calculated in accordance with the EN 50272-2 standard) and this does not usually require special aeration and ventilation studies.

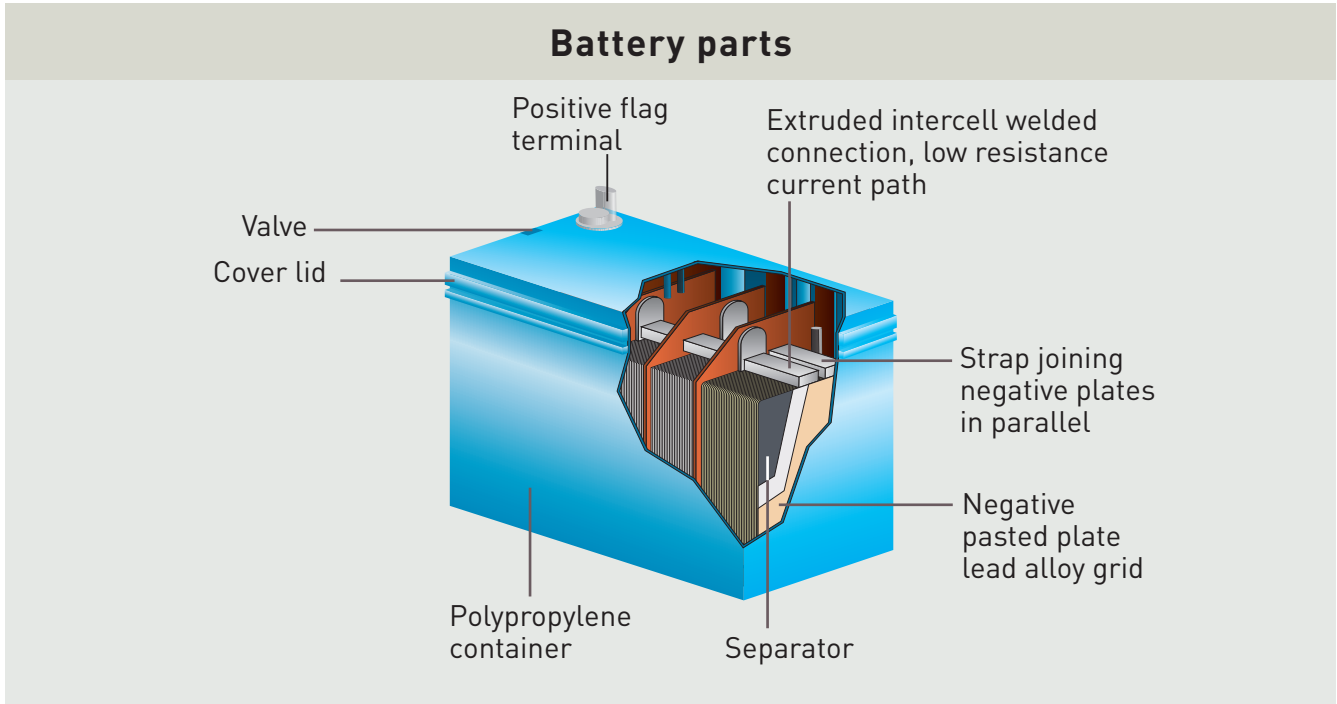

Moreover, Lead batteries can provide high current levels and operate discontinuously without necessarily reaching the end of discharge, without being affected by a "memory effect" like other types of batteries.

Battery manufacturers declare the "Expected Life Time" of batteries.

The most common cases for SLA batteries are: 5-6 years (Standard Life batteries) and 10-12 years (Long Life batteries).

This is an indicative value and is referred to standard working and environmental conditions that may not necessarily coincide with batteries' real operating conditions.

As for their the chemical nature in energy is storing and supplying, batteries are very sensitive to environmental conditions and to how they are used. In particular, high temperatures can drastically reduce batteries' life.

In general, the nominal operating temperature of VRLA Batteries is 20-25°C, for every 10°C the life expectancy is halved.

As for their use, the duration and intensity of the discharges and recharges influence the batteries' life. Excessively intense or low currents, very long and deep discharges, intense and prolonged recharges, etc. can reduce batteries' life and even damage them.

To avoid these phenomena, modern UPS systems have sophisticated battery management algorithms that optimise their use by monitoring and dynamically adapting voltages and currents in order to prevent deep discharges and conduct effective and safe recharges.

As well as extending their life, a "smart" battery management also allows to constantly monitor their status and reduces consumption levels associated with their recharge.



## A guide to choosing your UPS (continued)

Due to the phenomenon of self-discharge, batteries age and deteriorate even when they are not used for extended periods of time. To avoid incurring in a permanent loss of their capacity, it is recommended to do not leave the batteries disconnected for more than six/ten months. After this time, even new batteries that were initially in good condition may have recharging problems. In addition to self-discharge, also storage temperature negatively affects batteries' life.

Modern UPS systems allow to prevent this issue by managing to keep the batteries charged even when they are off (battery recharge in stand-by). So even when not used, one just needs to keep the UPS connected to the mains to keep the batteries active and alive.

To perform its functions the UPS must always be connected to the batteries and promptly report any disconnection or malfunctioning. Modern UPS systems have various automatic battery testing and monitoring functions and are able to inform the user about possible faults in order to prevent any problems even before the batteries reach the end of their life.

However, we recommend conducting periodical checks and maintenance on the batteries (at least once a year). It is also advisable to get a new set of batteries before they run out.

When choosing the batteries, to reach a certain back-up time it is important to also consider the recharging time. Of course, with UPS systems with the same nominal power, the greater the back-up time, the higher the number of batteries and, as a result, the longer the recharge time. To evaluate the right amount of batteries, it is recommended calculating the back-up time based on the actual load to protect, rather than the nominal power of the UPS.



## SMART CHARGE - ADVANCED BATTERY MANAGEMENT

To ensure power supply continuity in the event of a power failure, the batteries must be charged and in good condition. Therefore, a part of the energy absorbed by the UPS must be directed to charging the batteries. This is an additional consumption that cannot be eliminated. To reduce and optimize the cost of charging the batteries, UPS systems with an intelligent charging system (Smart Charge) are used. This system is based on the direct measurement of the operating parameters (Voltage and current) of the batteries and their variations in order to monitor the status of the battery in real time. The recharge follows a cycle consisting of several stages, whose duration and intensity depends on the state of the batteries. This advanced battery charge system has the benefit of having a fast charging time and the batteries are always charged constantly monitored.

At the same time this system does not stress the batteries, because when they reach their full charge, the charging intensity decreases until it reaches zero. In other words, the smart battery charge system optimises energy adsorption by limiting it to the amount actually required by the real charging status of the batteries. Moreover, it has the additional effect of extending the batteries' performance and life.

### Intelligent battery charge system (Smart Battery Charger)

**The "Smart Charger" three-stage intelligent charging system considerable extends batteries' life by even 50%, thereby halving the number of times they need to be replaced and environmental pollution due to their disposal.**

	year 1	year 2	year 3	year 4	year 5	year 6	year 7	year 8	year 9	Total
STANDARD CHARGING SYSTEM					1,00			1,00		2,00
SMART CHARGER						1,00				1,00
<b>SAVINGS</b>										<b>50%</b>



# A guide to choosing your UPS (continued)

## THE COST OF DOWNTIME

Calculating the economic impact caused by potential downtime may seem a complicated task. As a matter of fact, the productivity of modern companies is closely associated with that of information systems, so often unavailable information systems lead to downtime. To get an idea of the cost of downtime due to electrical issues, one just needs to multiply the unavailability time by the cost of the salaries of employees that depend on the system and add the lost profit (Total profit/unavailability time).

These costs must then be added to any costs required to restore the system, which instead depend on the frequency of the events and on how serious they are.

The main players in the UPS market have a number of distinguishing features, which need to be considered before making a choice: from the commitment in the Research and Development of power protection solutions to the focus on low energy consumption and the compliance with environmental regulations to the solutions aiming at reducing running costs and increasing flexibility and, in some cases, the compact design and appearance of the devices.

From a marketing point of view, customer satisfaction, maintenance processes (which must involve periodical technical check-ups), how fast support services are provided are clearly key elements and true distinguishing elements of the product offer. Basically UPS systems have three features: Safety, Reliability and Availability.



## ARCHITECTURE OF THE SYSTEM

### 1 DISTRIBUTED ARCHITECTURE

Distributed architecture is used in cases where the application to be protected is not particularly critical and when there are logistics issues (for instance: several rooms, pre-existing system, etc.).

BENEFITS	DRAWBACKS
It is possible to use existing wall sockets.	Complex management and monitoring: several UPS systems located in different areas.
Special sizing for the individual loads to be protected.	Long and complex maintenance: for instance, battery control and replacement to be conducted on many systems at different times.
Small independent UPS systems next to the loads to be protected.	Emergency shutdown to be managed for each machine.
Special expansion units or new parts for each individual UPS work station.	Difficulty in achieving redundancy.
Existing UPS systems can be retained and used together with new ones.	Higher running and maintenance costs. Greater electrical consumption.

#### A dedicated UPS for each system load

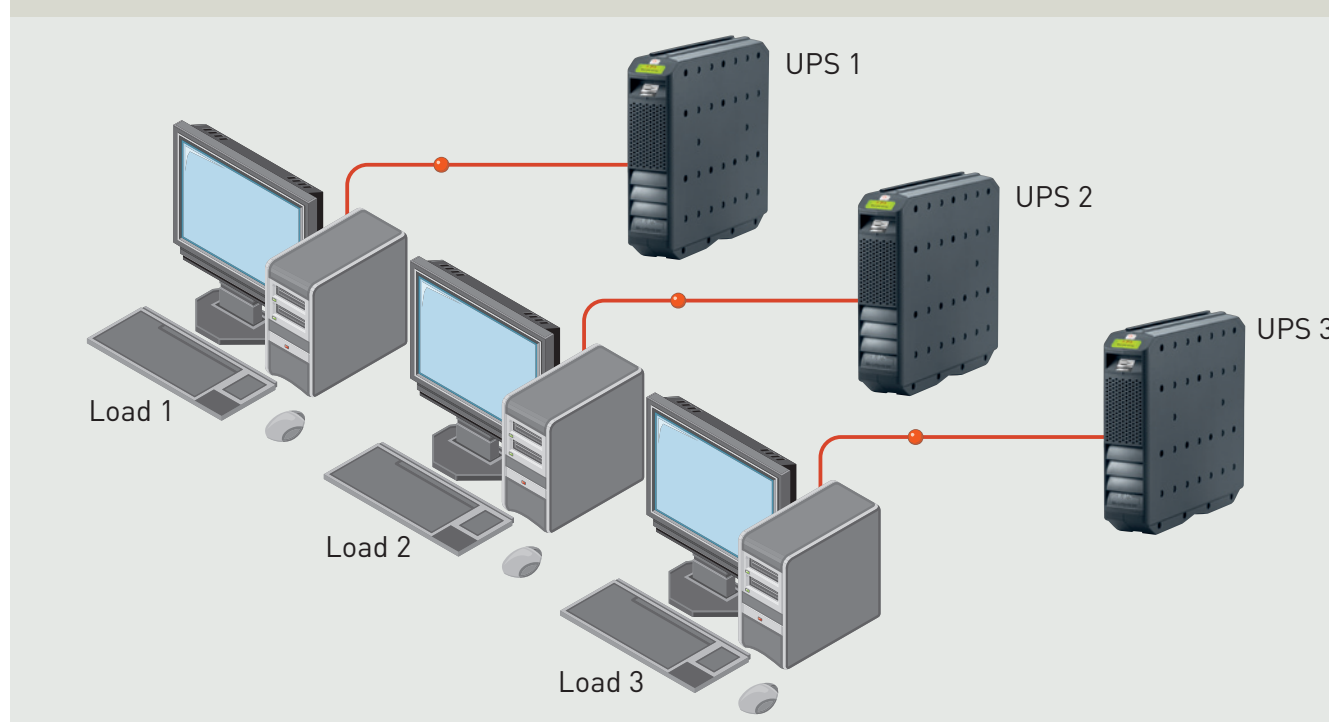

# A guide to choosing your UPS (continued)

## 2 CENTRALISED ARCHITECTURE

Centralised architecture is a preferable solution to protect the entire structure:

BENEFITS	DRAWBACKS
Just one system to install and manage (simpler and more convenient than several small systems)	A single system may represent a un single point of failure (critical nature of the distribution). This can be avoided with redundant installations with a resulting increase in costs.
A single system to maintain (easier and more economical than many small systems).	The UPS is usually far away from the load to be protected.
Greater longevity for both the UPS and the Batteries.	Greater overall dimensions.
Greater energy efficiency (Lower Electric consumption).	Installation and wiring costs, together with costs to extend the back-up time can be high.
The UPS is generally placed in a safe and protected utility room with optimal environmental conditions.	Installation and maintenance must generally be conducted by specialised technical personnel.

### A single UPS to protect several system loads

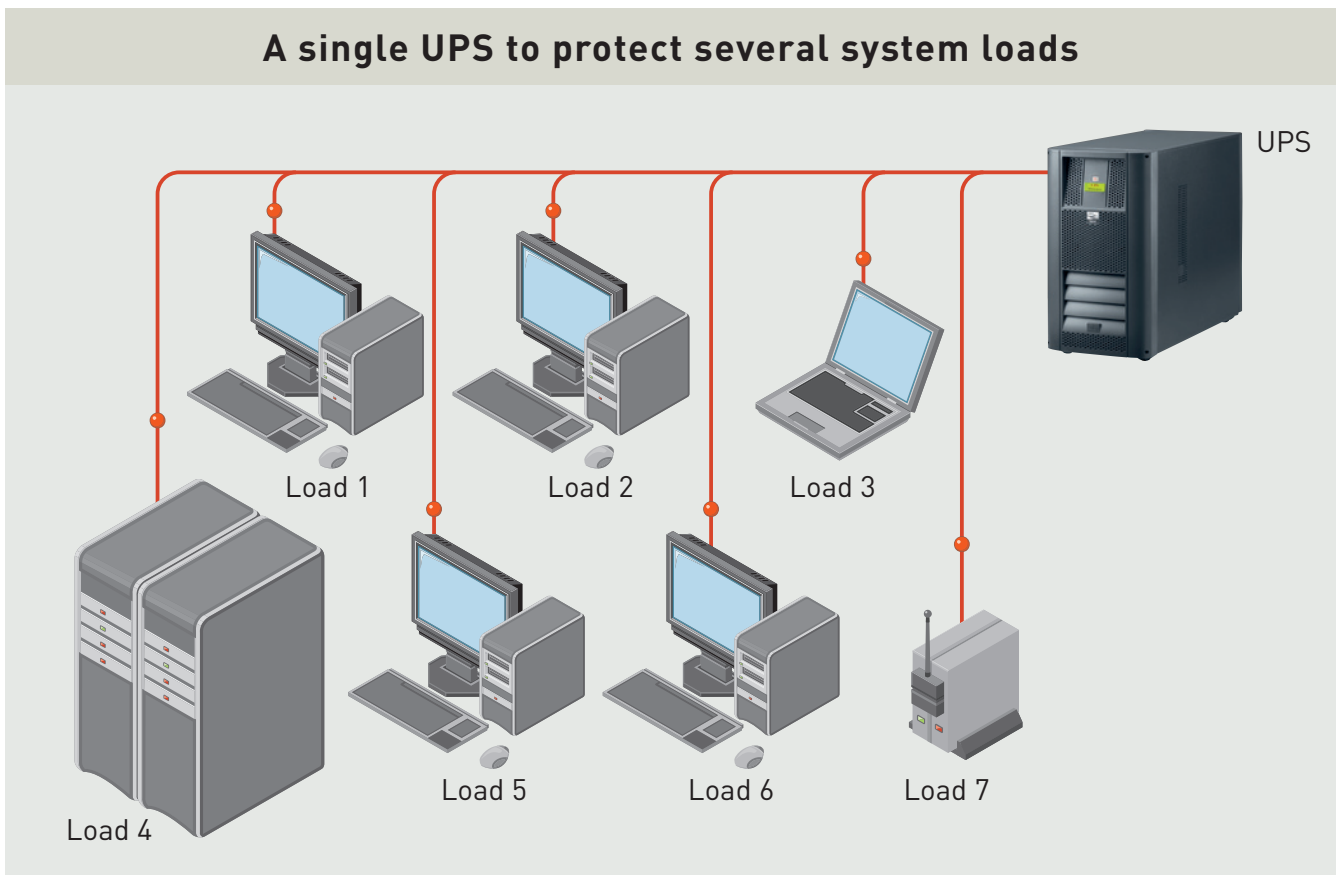



### 3 MODULAR ARCHITECTURE

Modular architecture is an interesting solution to protect a company's key areas. The modules are UPS systems that contribute all together to powering the load:

BENEFITS	DRAWBACKS
All the Benefits of centralised Architecture.	The initial purchase cost may be higher.
Easy to achieve internal redundancy by adding one or more modules.	Installation and maintenance may need to be conducted by specialised technical personnel.
Easier and faster installation and expandability compared with the centralised solution.	Greater overall dimensions compared to distributed architecture.
Easier and faster to maintain and repair.	
More compact compared to the centralised solution (especially in case of redundancy).	



With modular UPS systems the configurations can be changed to increase the back-up time and power without replacing the machine.

# A guide to choosing your UPS (continued)

## 4 GRANULAR MODULAR ARCHITECTURE

Granularity consists in having compact modules with low power levels order to let the system less sensitive against the malfunction of an individual module.

BENEFITS	DRAWBACKS
Easier and faster installation, maintenance and expandability compared with the Modular solution.	The initial purchase cost may be higher.
Easy to achieve internal redundancy and immunity against failures. A single module involves a small power loss in relation to the nominal power.	
In the event of a failure, minimal downtime for non-redundant configurations.	
Greater energy efficiency, lower consumption.	
Accurate and optimal sizing: with small modules it is easier to attain the actual power of the load.	

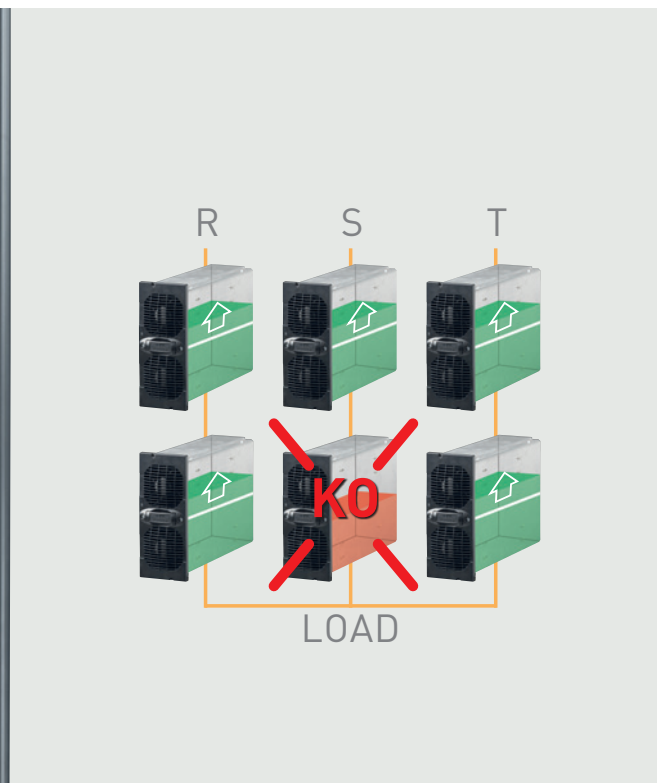

With the "granular" modular architecture you can only replace one element, as needed, ensuring the service continuity of the whole system.

## SYSTEM SIZE

To obtain a uninterruptible power supply- and therefore suitable sized in relation to the load to be protected – it is necessary to clearly identify various aspects.

This will allow us to achieve the best integration of all the parts that make up the source itself.

The elements required to size the UPS correctly are:

1. Maximum power of the load to be protected.
2. Performance of the UPS to be used.
3. Features of the UPS system's input circuit.
4. Any additional energy sources.

The power of the UPS input must have is the result of the sum of the UPS' power plus the "lost" power generated by its performance.

$$P_{line} = \frac{P_{UPS}}{\eta_{UPS}}$$

The conversion efficiency of the UPS must always be declared by the manufacturer of the UPS itself. Usually the declared efficiency does not consider the charging of the batteries, which would involve an increase in the amount of power absorbed. However, this is negligible considering that normally UPS systems are never used at full load but often at around 75-80%.

The vast majority of UPS systems do not have a correct absorption. Indeed, as they are non-linear loads, they can cause disturbances to the mains itself.

These disturbances are caused by harmonics generated by input circuits that have not been set up correctly.

Therefore the plant engineer must also take into account this aspect, especially when it is recommended to choose a UPS with a limited THDi value of about 3% max.

This is only allowed in UPS systems with input PFCs (Power Factor Corrector).

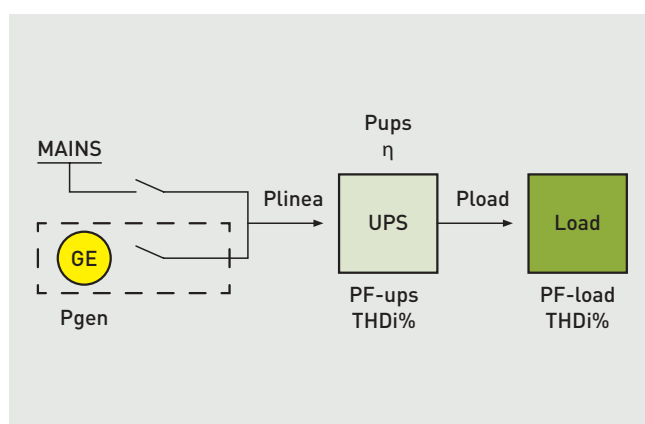

# A guide to choosing your UPS (continued)

## 1 SIZING WITH POWER-SUPPLY UNITS

Power-supply units may show malfunctions if associated with a UPS without a input PFC circuit, as an harmonic distortion of the current could cause considerable disturbance to the alternator, which could lead to a shutdown.

For conventional UPS systems, to avoid this potential issue it is necessary to use a generator 1.5 times or twice the size in relation to the power of the UPS, which would result in wasted energy and money.

Therefore also in this case it is necessary to examine the architecture of the UPS systems correctly.

When determining the size of an electrical system, special attention should be placed on selecting the cables. Indeed, it is necessary to take account various elements such as voltage, current, the length of the line, the ambient temperature and the intended type of installation.

The IEC 60364 standard defines the capacities of the conductors to be used for fixed installations and takes into account the elements listed above.



ARCHIMOD three-phase modular UPS.

## 2 SIZE OF THE NEUTRAL CABLE

In three-phase distribution systems, where UPS systems with high harmonic distortion or no input PFC circuit are used, there is often strong unbalance on the line, which results in the need for an oversized neutral cable.

So a UPS with a correct and balanced absorption requires a neutral conductor with a smaller cross-section.

In single-phase systems the size of the neutral cable does not represent an issue, as it must have the same cross-section of the phase conductor.

## 3 SIZE OF THE PROTECTIVE DEVICE WITH CIRCUIT BREAKER

Typically, UPS systems with On-Line double conversion technology (VFI) are fitted with a bypass circuit which, in the event of a UPS failure or overload, automatically connect the load directly to the mains.

In this case, the size of the upstream circuit breaker must take into account the UPS' maximum allowed current overload.

## 4 SIZE OF THE PROTECTIVE DEVICE FITTED WITH A FUSE

Normally all UPS systems already have an integrated input fuse protection with current values adequately set by the manufacturer.

Therefore it is not necessary to fit an additional protection of this type in the system.

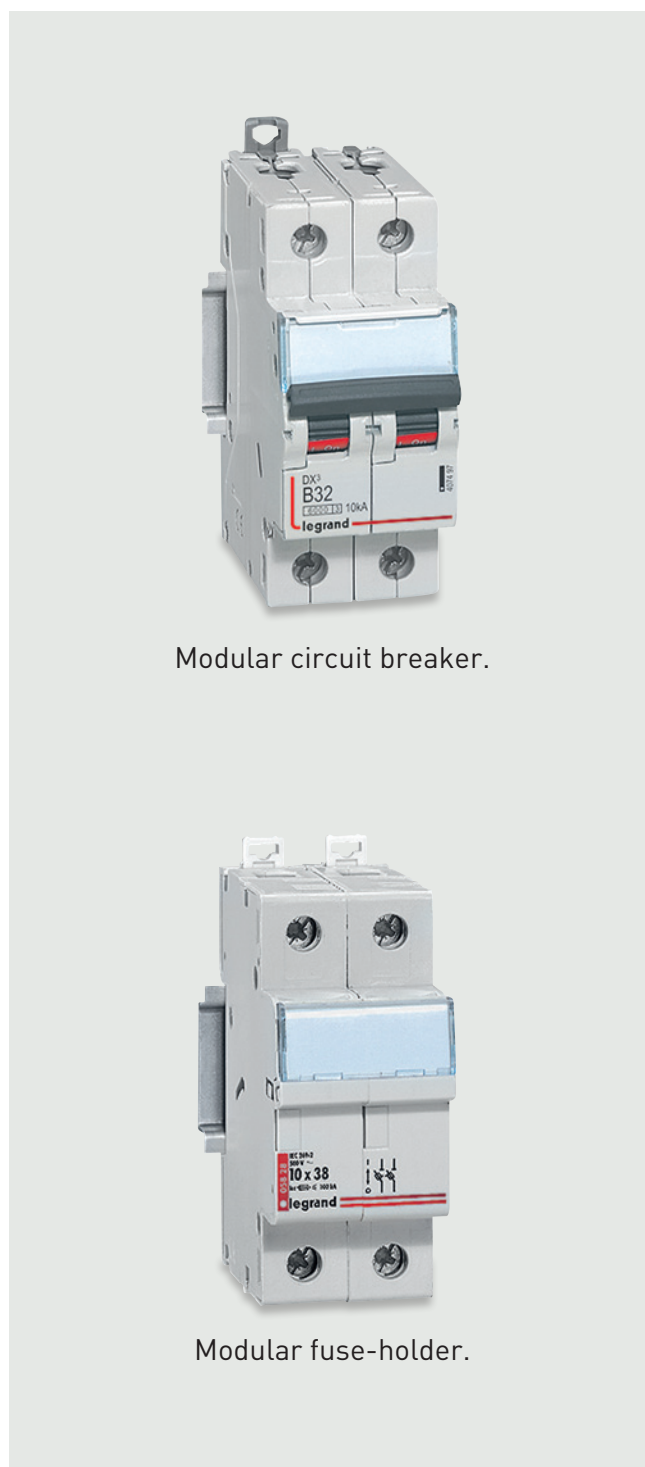

Modular circuit breaker.

Modular fuse-holder.

# A guide to choosing your UPS (continued)

## PROTECTION WITH EARTH LEAKAGE CIRCUIT BREAKER

In cases where it is necessary to use earth leakage protections on the load is important that the UPS does not alter the output neutral/earth arrangement in relation to the arrangement at the input. The preservation of the neutral/earth arrangement is certainly guaranteed in UPS systems with a Feed-through Neutral cable, where the input neutral coincides with the output neutral. When using earth leakage protections, one must consider that all electric devices employ internal EMC filters, which generate small leakage currents to earth. When they are summed up and added to the UPS' leakage current, they may cause an ill-timed intervention of the differential. In this regard, to achieve a greater selectivity on the system, we recommend using 0.03A residual current devices on the UPS output to protect the loads against indirect contact and use 0.3A or more powerful residual current devices upstream of the UPS.

This way the loads are protected by the switches downstream of the UPS and the leakage currents of the loads (even if added to the leakage currents of the UPS) will never cause the protection upstream of the UPS to intervene at the wrong time.

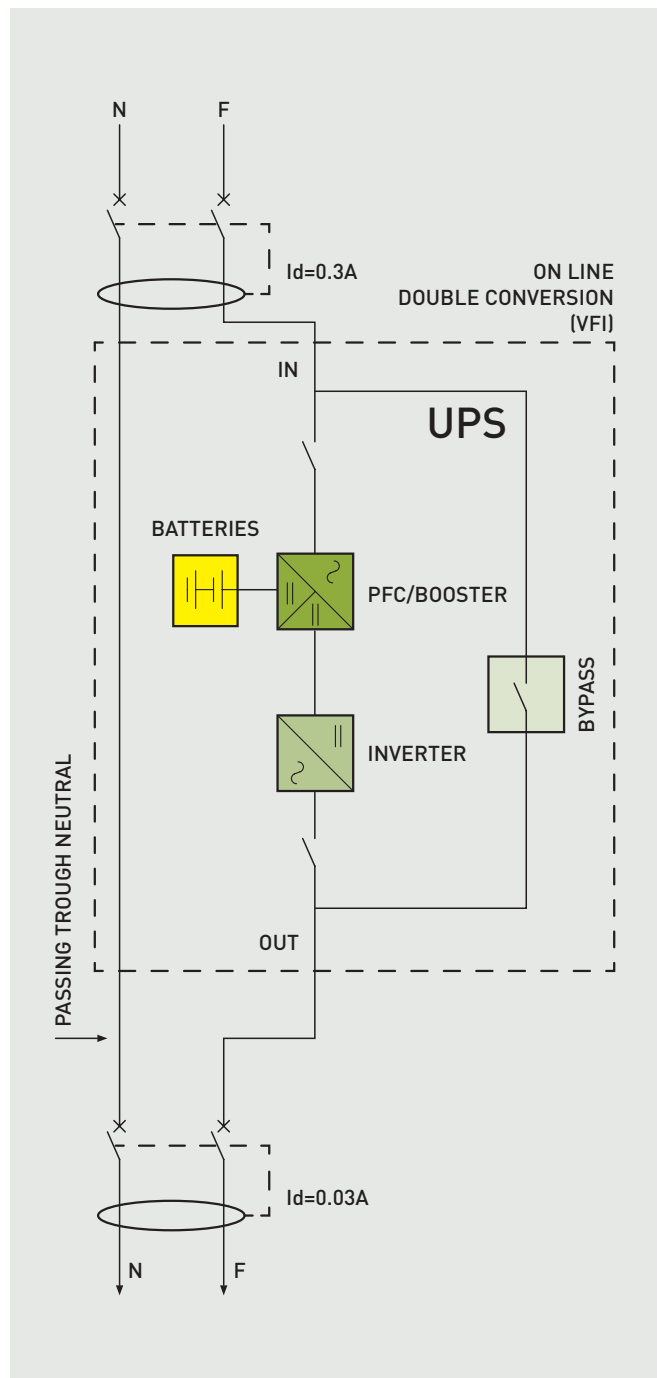
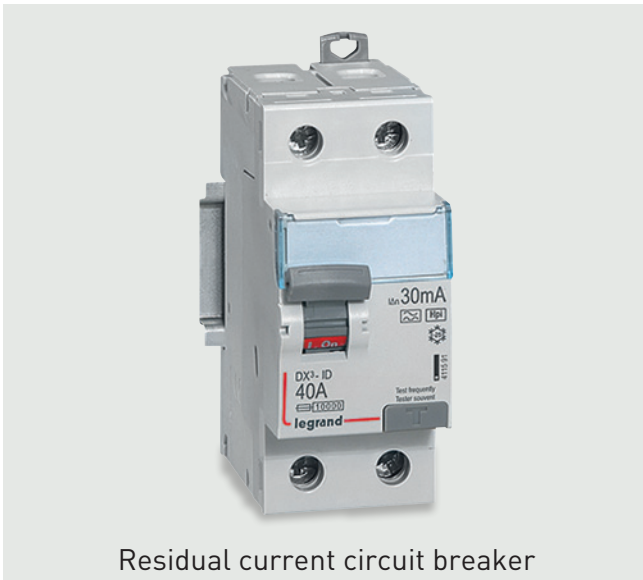

## POWER CONVERSION EFFICIENCY

Electronic power conversion circuits (PFC Rectifier and Inverter) certainly represent the main components of the UPS. The energy transferred to the load passes through these circuits, which are therefore particularly stressed from both an electrical and thermal point of view. The process of converting energy requires energy and the losses due to parasitic effects are added to this process. Usually, except for battery chargers, conversion circuits are the ones that use the highest amount of energy in the UPS.

To reduce and optimize this consumption, latest generation UPS systems employ high efficiency and high performance electronic components (IGBT-Insulated Gate Bipolar Transistor) that ensure a high quality energy conversion with very low consumption levels and compact overall dimensions.

Using IGBTs allows to employ high frequency monitoring and control technologies (PWM-Pulse Width Modulation). This means transformers are not required (Transformerless technologies) and the use of passive filters is reduced to a minimum. The drastic reduction of these elements removes all the losses occurring in iron and copper parts and considerably reduces the overall dimensions, weight and costs of the UPS. Moreover, by reducing losses also the heat that needs to be removed is reduced. This means that also cooling and ventilation systems require less energy and are lighter and more compact.



The European Code of Conduct published in 2007 defines the minimum efficiency levels based on the size and load levels for the new UPS systems launched on the market.

Mode	from 1-1-2008 to 31-12-2009			
	UPS range: ≥10 - <20kVA	UPS range: ≥20 - <40kVA	UPS range: ≥40 - <200kVA	UPS range: ≥200kVA
Normal mode <b>Minimum</b> efficiency measured according to EN 62040-3 Annex AA				
25% of nominal power	83 %	84 %	86.5 %	89 %
50% of nominal power	89 %	89.5 %	90.5 %	92%
75% of nominal power	90.5 %	91 %	92 %	93 %
100% of nominal power	91 %	91.5 %	92 %	93 %

# A guide to choosing your UPS (continued)

## EFFICIENCY AND SIZE

Latest-generation static UPS systems place a special focus on the energy drawn from the mains supply and the one provided to the equipment to be powered, as the main cause of wasted energy depends precisely on the overall performance of the system.

The performance is also related to the system's usage percentage (and increases as this percentage increase). So special attention must be placed on the accurate sizing of the UPS, as an oversized system also has negative economic effects on electrical consumption, along with higher initial costs.

One must also consider that in many applications, the load may not be constant but vary throughout the day and week. In these cases it is not enough to have a high efficiency at the nominal power, because for most of its life, the UPS operates with lower loads. In general the best solution is to choose a UPS with a high performance as constant as possible also with load percentages below 50%, as shown in the figure. This why the performance of the UPS does not depend on the actual load connected.

Batteries, too, influence the overall performance of the UPS System. Indeed, they need to be charged after being used during a power failure and kept charged when the mains voltage is on. So part of the energy absorbed by the UPS is delivered to the batteries with additional heat loss and dissipation. To reduce the consumption of energy associated with the batteries to a minimum, the battery chargers must have an efficient electronics controlled with intelligent software algorithms based on the actual conditions of the batteries.

Intelligent charging, management and monitoring algorithms allow to charge the batteries accurately and effectively, thereby reducing consumption, limiting the charging time and using the batteries in the best possible way. Using the batteries properly extends their life, with resulting savings on the number of times the batteries need to be replaced during the life of the UPS.

Another solution to consumption associated with the batteries is to determine the system's back-up time in relation to the actual load to be powered up for the entire duration of the power failure. In addition to the resulting energy savings, a correct battery size also leads to lower installation and maintenance costs, along with a smaller overall dimensions.

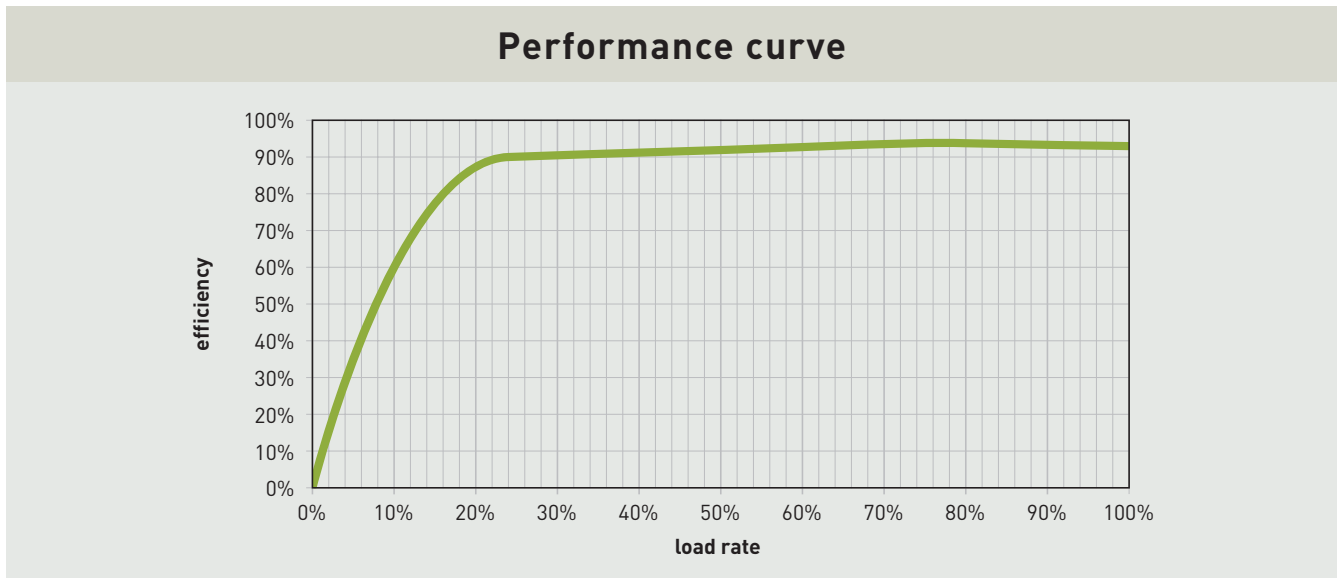



## MANAGING ENERGY WITH MODULAR UPS SYSTEMS

In terms of the economical and rational use of energy in UPS applications, modularity brings great benefits. Modular UPS systems consist of independent and synchronised modules that are all involved in powering and protecting the load. These are low power modules and therefore are compact, lightweight and have low consumption levels.

The nominal power of these UPS systems depends on the number of modules installed. If the load increases, it is possible to increase the system's power by adding other modules. It is also possible to install more modules than the ones required to achieve internal redundancy and ensure continuity of operation even in the event of a failure of a single module.

Modular UPS systems allow for an optimal configuration of the number of modules and for nominal power values that are very similar to the values required by the loads. This avoids unnecessary and costly oversized systems.

Modularity also leads to energy savings and lower installation and maintenance costs of the UPS. As they are lightweight and compact, the modules are easy to transport and replace. So it is possible to handle and maintain modular UPS systems with minimum personnel and means of transport and with very little downtime. Moreover, high-end modular machines are "self-configuring" (self-sensing) and do not require programming or hardware or software setting when the modules are installed or replaced. Therefore no special tools and devices are required to operate with these UPS systems.

Therefore modularity allows to optimize consumption and costs both in terms of energy absorption and in terms of managing and operating the system. Batteries, too, influence the overall performance of the UPS System. Indeed, they need to be charged after being used during a power failure and kept charged when the mains voltage is on. So part of the energy absorbed by the UPS is delivered to the batteries with additional heat loss and dissipation.

To reduce the consumption of energy associated with

the batteries to a minimum, the battery chargers must have an efficient electronics controlled with intelligent software algorithms based on the actual conditions of the batteries. Intelligent charging, management and monitoring algorithms allow to charge the batteries accurately and effectively, thereby reducing consumption, limiting the charging time and using the batteries in the best possible way.

In addition to the resulting energy savings, a correct battery size also leads to lower installation and maintenance costs, along with a smaller overall dimensions.



Megaline from 1250VA to 10000VA.

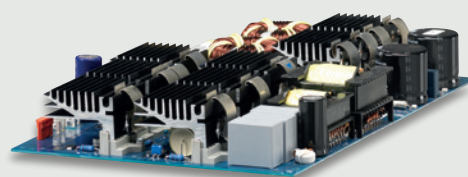

1250 UPS module.

# A guide to choosing your UPS (continued)

## 1 SINGLE-PHASE MODULAR UPS SYSTEMS

Single-phase modular UPS systems definitely offer first-class performance levels and features. Depending on the power levels, they are available in two versions, single cabinet or double cabinet. Each modular UPS consists of a variable number of power boards and batteries, based on powers levels and uptime. Each module is a VFI SS 111 class 1250VA UPS with PFC rectifier and high frequency PWM-controlled inverter.

## 2 THREE-PHASE MODULAR UPS SYSTEMS

LEGRAND'S range of three-phase UPS systems consists of Modular UPS systems suited to provide protection against sudden power failures in critical environments such as data centres and industrial or emergency applications. These modular UPS systems offer a number of benefits in terms of the reliability and overall management costs they entail. Modular and expandable systems allow to optimize investments in the UPS systems by adapting them to actual needs, without precluding future expansion and avoiding an unnecessary waste of energy. These UPS systems can be configured to increase or decrease both their power and back-up time as needed. As well as allowing expandability based on small steps, the modular philosophy based on compact modules (both power and battery modules) also allows to manage maintenance operations in a simple and cost-effective way. LEGRAND's three-phase UPS systems introduce a new model of modularity that rather than offering pre-set power reductions, offers the opportunity of choosing the "on-demand" configuration that best suits your needs.

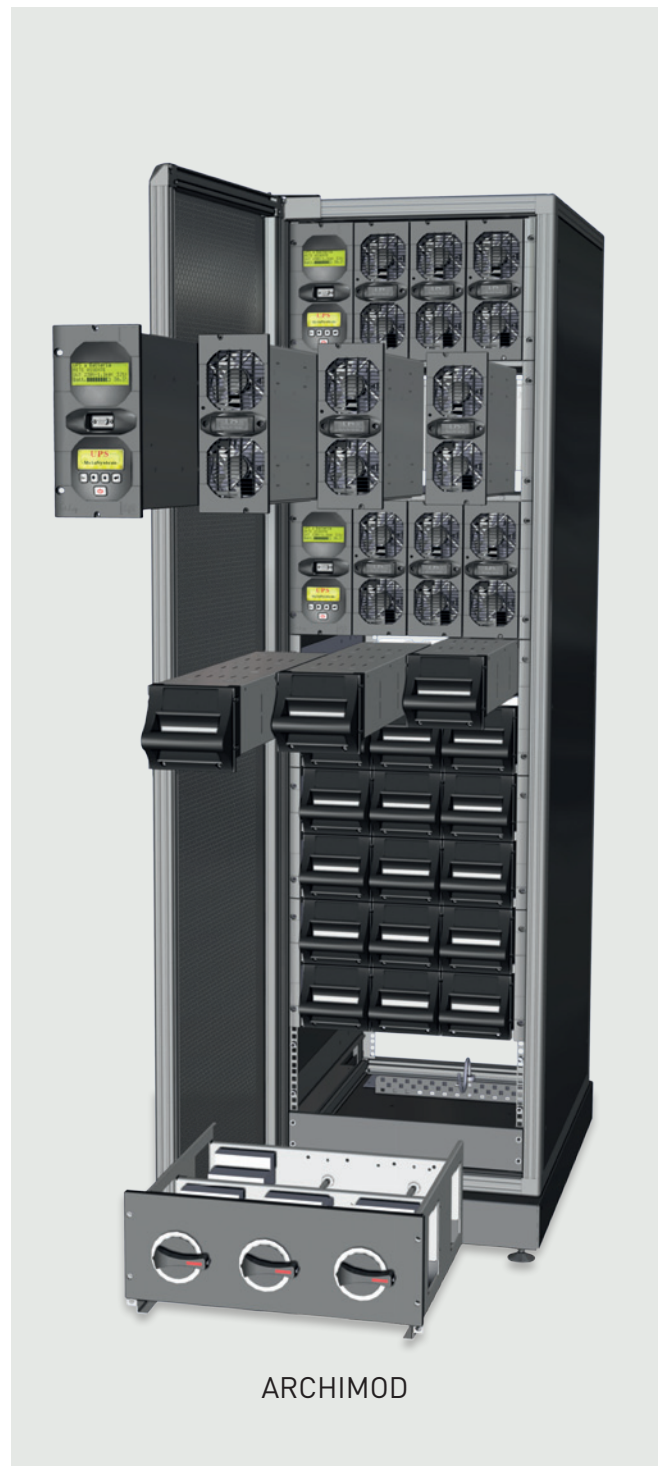

## POWER FACTOR AND HARMONIC DISTORTION

An almost unity power factor at the input (PFC = 0.99 already with a load of just 20%) and a low harmonic distortion (THD <3%) ensure a minimal impact on the mains and a high level of energy efficiency that results in lower energy management costs.

Indeed, the more the power factor moves away from the unity value, the greater the reactive power absorbed by the mains, leading to higher operator tariffs. Plus, the reduction in resulting voltage drops substantially limits the waste of energy.

The correction of the power factor also removes the need to implement a power factor correction system and to increase the size of a potential power-supply unit upstream, which in the past had to be at least 30% of the UPS' nominal power. This allows for additional savings related to installation of the uninterruptible power supply system. A high power factor also determines a reduction of the losses on the conductors due to a lower intensity of the circulating current.

Moreover, a careful control of the current absorbed by the mains (PFC) allows to achieve a very low harmonic distortion of the input current (THD <3%). The harmonic distortion caused by non-linear loads on power supply lines means that the currents in the system are higher than expected and that they contain harmonic frequency components: a phenomenon that may be seriously underestimated because these are currents that cannot be measured with standard portable instruments supplied to maintenance personnel.

Even if the current remains within the capacity of the overload protection device, the conductors operate at higher temperatures and cause a waste of energy generally equal to 2-3% of the overall load.

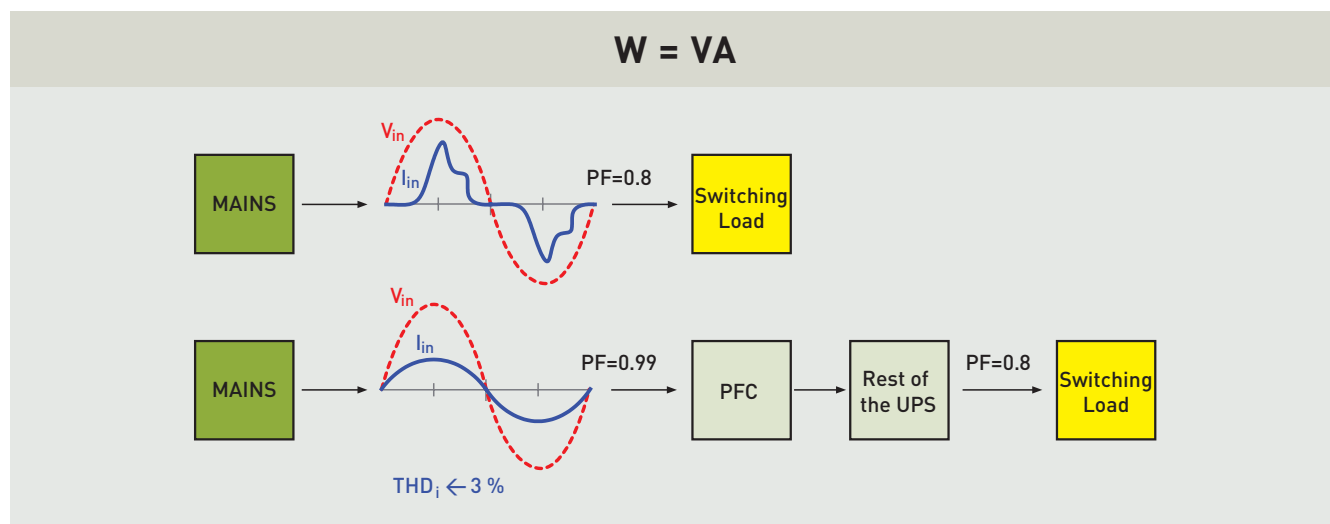

# UPS management and communication

Very often UPS systems require remote communication to allow for faster and more effective diagnostics during the various operating stages and quick maintenance operations.

These functions may be obtained by fitting the equipment with communication boards and network interface cards and providing additional monitoring services to ensure maximum safety and peace of mind for the customer.

## LOCAL PROTECTION

To protect an individual computer (server or work station) and its relative devices, one just needs to use a RS232 or a USB connection and install the management software on the system to be protected. If your computer is connected to an IP network you can also receive the UPS' alarm messages on your computer via pop-up messages and e-mails and graphically view operational data through specific monitoring programs. The benefit of this type of management is that implementation costs are very low, but there is a limitation: the UPS must be installed near the system to be protected.

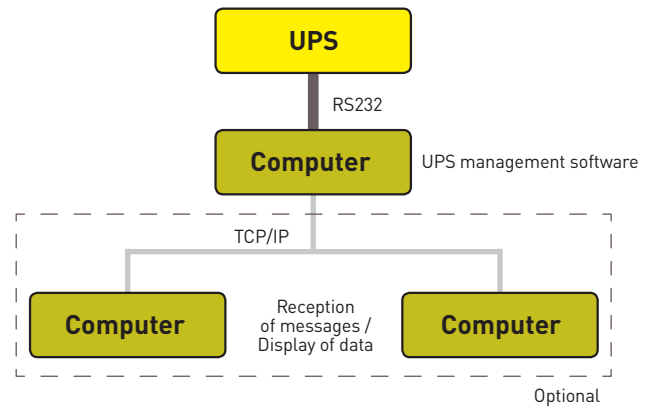

## EXTENSION OF THE LOCAL PROTECTION

If there is a higher number of computers to be controlled, it is possible to use the solution described above. However, a special software "agent" must be installed on the other computers. This receives and executes controls sent from the computer interfaced with the UPS.

Again in this case implementation costs are very low, but if the computer interfaced with the UPS shuts down (fault, maintenance, updates, etc.), the management system is completely prevented from operating.

As a result, one can no longer receive the alarm messages and this endangers the integrity of the remaining computers.

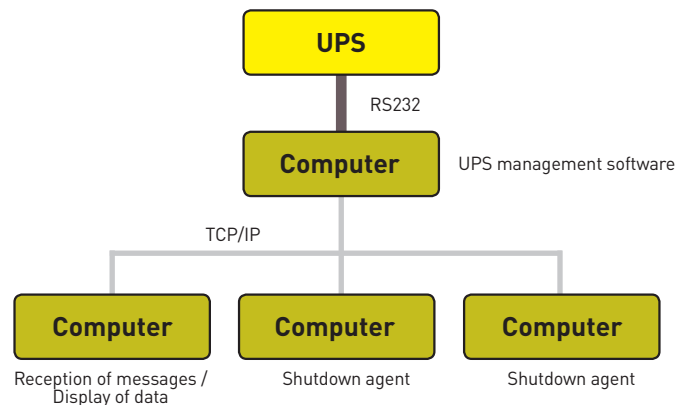

## INTEGRATION INTO THE IP NETWORK

This type of installation requires that the UPS is connected to a special network interface inside which the software is installed. The network interface card is in turn connected to the IP network. As the UPS is connected directly to the IP network, its management system is able to send e-mails and pop-up messages, and turn computers on and off. The protection of the various computers is ensured by installing a software agent that receives the controls from the network interface of the UPS.

This solution has a number of benefits:

- The UPS can be installed even far away from the systems that it needs to protect.
- The whole management no longer depends on a single computer and this effectively ensures the safety of all the connected devices.
- The data can be viewed from any web browser without having to install special software.

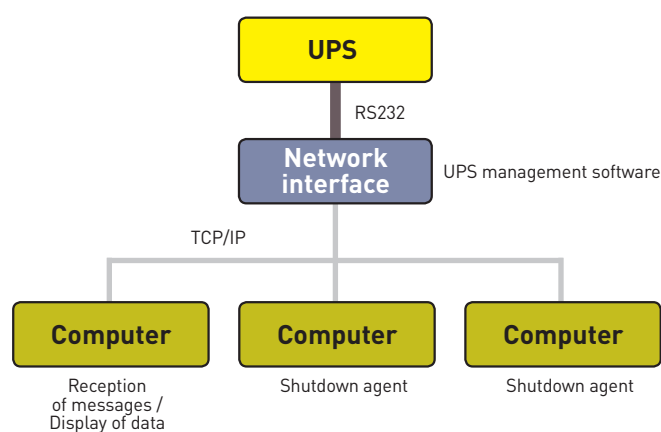

# Management and communication of the UPS systems (continued)

## MANAGING SEVERAL UPS SYSTEMS

To manage several LEGRAND UPS systems it is necessary to use a software application that can continuously monitor even a large number of UPS systems installed locally or in remotely.

All the alarms generated by the UPS through their respective management systems are intercepted through the IP network by this application. This stores the alarms in a database and sends a series of pop-up messages and e-mails to operators who, by connecting themselves via online browsers, are able to quickly identify the UPS that generated the alarm and carry out a full and efficient diagnosis.

A typical example of how this application is used is represented by a financial institution:

- A UPS is installed in each branch and controlled by one of management systems described earlier. This manages and protects the local network.
- The various local networks are permanently connected with each other.
- In the head office there is the monitoring station that continuously monitors all the UPS systems.

The advantage of this solution lies in using a standard monitoring and alarm reception system that allows to manage any UPS without having to know its IP address.

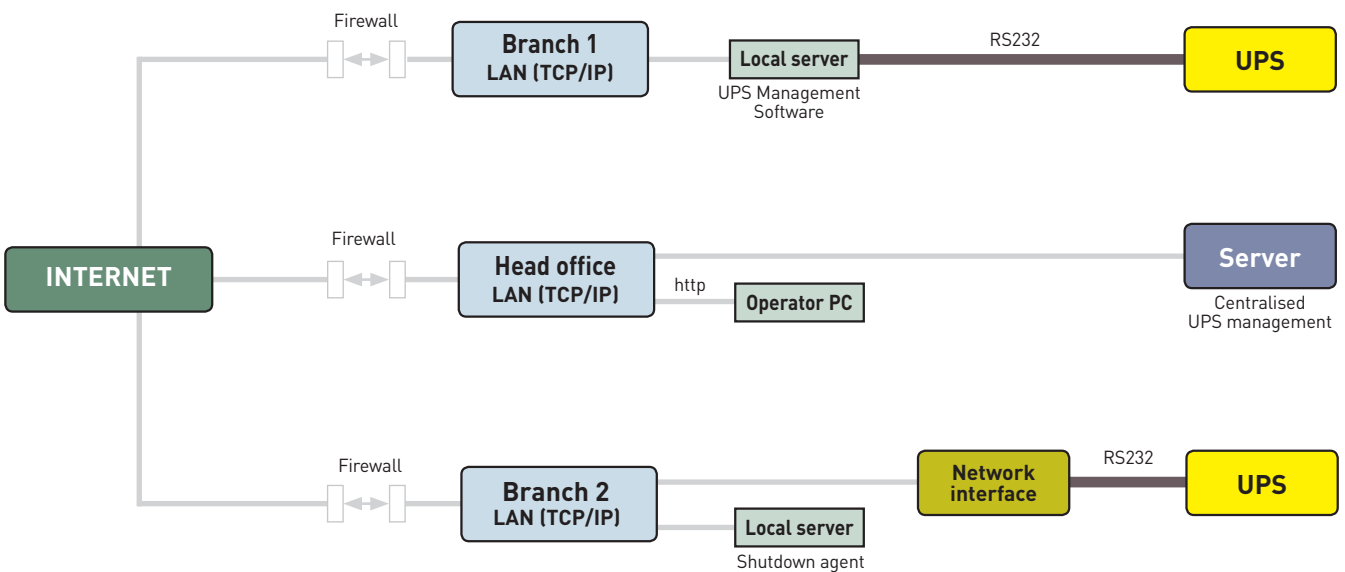

## ENVIRONMENTAL MONITORING

There are situations where the monitoring service carried out by the UPS is not enough and it is necessary to also control the surrounding environment.

By using network interfaces it is possible to monitor – through a dedicated analogue sensor – the temperature and humidity of the room or of a specific rack cabinet and send e-mails or execute controls on remote machines if the value detected falls outside the preset limits.

If there is the need to use more than one sensor it is possible to interpose a special device which allows

to connect up to 8 UPS systems between the interface and the sensor itself.

Historical data on the trends of the values detected by the sensors is stored in a special log file, which can be displayed graphically or exported to be analyzed and filed at a later stage.

It is also possible to monitor the status of digital inputs (for instance door opening microswitches or fault signalling contacts of the air-conditioning system) and control hardware devices such as, for example, signal lights or sirens: once again it is possible to send e-mails or run controls on remote computers.

### Monitoring of a single sensor

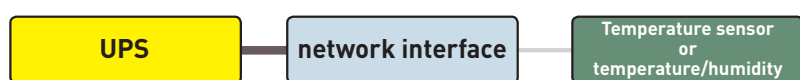

### Monitoring several sensors

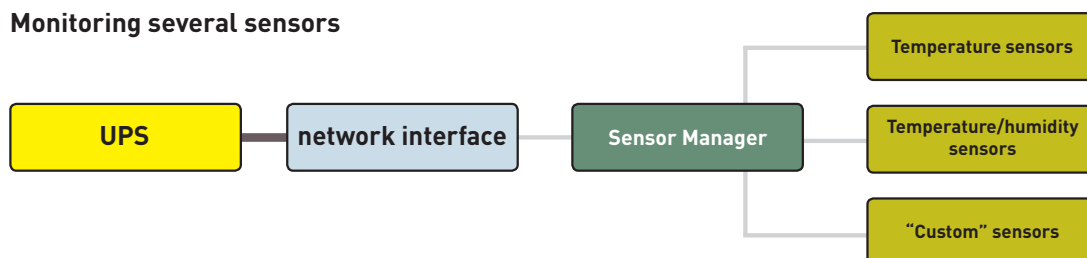

### Monitoring digital inputs and controlling hardware devices

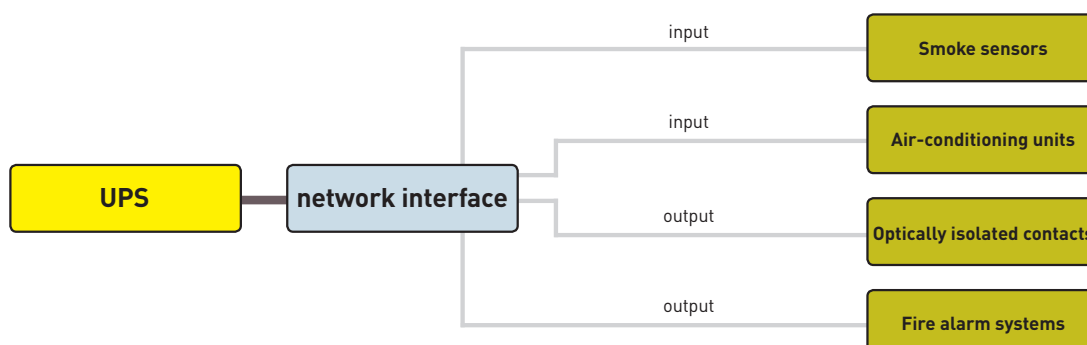

# UPS technical features

The range of UPS systems consists of modular, conventional and line-interactive machines with a power of up to 10kVA.

Here below are the technical features of the various types of UPS systems.

## NIKY AND NIKY-S - SINGLE-PHASE LINE-INTERACTIVE UPS SYSTEMS

ITEM	3 100 02	3 100 03	3 100 04	3 100 05	3 100 06	3 100 20	3 100 07	3 100 08
<b>GENERAL FEATURES</b>	LI				LI-S			
Nominal power (VA)	600	800	1000	1500	1000	1500	2000	3000
Active power (W)	300	400	600	900	600	900	1200	1800
Technology	Line-interactive VI							
Waveform	Pseudo-Sinusoidal				Sinusoidal			
<b>INPUT</b>								
Input voltage	230 V							
Input frequency	50-60 Hz							
Input Voltage Range	160V-290V							
<b>OUTPUT</b>								
Output voltage	230V ± 10%							
Output frequency (nominal)	50/60 Hz +/-1%							
THD Output voltage	< 3% with linear load							
<b>BATTERIES</b>								
Number of batteries	1	1	2	2	2	2	4	4
Battery series Type/Voltage	12V, 7Ah	12V, 9Ah	12V, 7Ah	12V, 9Ah	12V, 7Ah	12V, 9Ah	12V, 7Ah	12V, 9Ah
<b>COMMUNICATION AND MANAGEMENT</b>								
Display and Signals	One button and two LEDs to monitor the status of the UPS in real time.		One button and four LEDs to monitor the status of the UPS in real time.		Three buttons and three LEDs to monitor the status of the UPS in real time.			
Communication Ports	RS232, USB and RJ11/RJ45 serial ports							
Remote Management	available							
<b>MECHANICAL FEATURES</b>								
Dimensions H x L x D (mm)	171x95x349		239x147x354		247x173x369		247x173x465	
Net Weight (kg)	7	7,5	13	16	13	15	22	24
<b>ENVIRONMENTAL CONDITIONS</b>								
Operating temperature [°C]	0 - 40°C							
Relative humidity [%]	0÷95 % non-condensing							
Noise level at 1 m (dBA)	<40							
<b>CERTIFICATIONS</b>								
Standards	EN 62040-1, EN 62040-2, EN 62040-3							





## MEGALINE - SINGLE-PHASE MODULAR UPS SYSTEMS

ARTICOLO	3 103 50	3 103 52	3 103 54	3 103 56	3 103 60 + 3 107 78	3 103 63 + 3 107 79	3 103 66 + 3 107 80	3 103 69 + 3 107 81	3 103 72 + 3 107 82	3 103 79	3 103 81	3 103 83	3 103 85
<b>GENERAL FEATURES</b>	<b>Single CABINET</b>				<b>Double CABINET</b>					<b>RACK</b>			
Nominal power (VA)	1250	2500	3750	5000	5000	6250	7500	8750	10000	1250	2500	3750	5000
Active power (W)	875	1750	2625	3500	3500	4375	5250	6125	7000	875	1750	2625	3500
Max expandability (VA/W)	5000/3500				10000/7000					5000/3500			
Technology	On-line double conversion (VFI-SS-111)												
System	Modular, Expandable, N+X Redundant with 1250 VA power boards in a single cabinet												
<b>INPUT</b>													
Input nominal voltage	230 V												
Input voltage range	184 V ÷ 264 V at 100% of the load												
Minimum operating voltage	100 V at 50% of the load												
THD Input current	< 3%												
Input Power Factor	> 0.99 from 20% of the load												
Input frequency	50 Hz / 60 Hz ± 2% autosensing												
<b>OUTPUT</b>													
Output voltage	230 V ± 1%												
Output frequency	50 Hz / 60 Hz synchronised												
THD Output voltage	< 1% with non-linear load												
Waveform	Sinusoidal												
Crest Factor	3.5: 1												
Performance when connected to the mains	92% at 100% of the load												
Allowed overload	300% for 1 sec. - 200% for 5 sec. - 150% for 30 sec.												
<b>UPTIME</b>													
Back-Up Time (min)	13												
Back-Up Time expandability	yes												
<b>EQUIPMENT</b>													
Bypass	Static and Electromechanical, automatic and internally synchronised (due to overload or operating fault).												
Signals and Alarms	Large 4-line alphanumeric display, multi-colour status indicator, audio signal												
Communication Ports	no.1 RS 232 port, no.2 logical ports												
UPS Communicator Software	Can be downloaded from the website free of charge (after requesting the activation code)												
Protections	Electronic protections against overloads, short-circuits and excessive battery discharge. Operation stops when the uptime ends. In-rush current limiter at start-up. Sensor to connect the neutral cable correctly. Back-feed protection (electrical safety insulation of the input plug during battery-based operation). EPO contact (complete shutdown in the event of an emergency)												
IN/OUT mains connection	Standard German / Clamp connector with universal multiple socket outlet (Italian/German standard)												
<b>MECHANICAL FEATURES</b>													
Net weight (kg)	23.5	34	43	53	24 + 50	26.5+57.5	29 + 65	31.5+72.5	34 + 80	23.5	34	43	53
Dimensions (lxhxd) (mm)	270 x 475 x 570				2 x (270 x 475 x 570)					270 x 475 x 570			
Installed power boards	1	2	3	4	4	5	6	7	8	1	2	3	4
Free power expansion slots	3	2	1	-	4	3	2	1	-	3	2	1	-
Installed battery kits	1	2	3	4	4	5	6	7	8	1	2	3	4
Free uptime expansion slots	3	2	1	-	6	5	4	3	2	3	2	1	-
<b>ENVIRONMENTAL CONDITIONS</b>													
Operating temperature (°C)	0÷40												
Relative humidity (%)	20÷80 non-condensing												
Noise level at 1 m (dBA)	< 40												
<b>CERTIFICATIONS</b>													
Standards	EN 62040-1, EN 62040-2, EN 62040-3												

# UPS technical features (continued)

## ARCHIMOD AND TRIMOD - THREE-PHASE MODULAR UPS SYSTEMS

ITEM	ARCHIMOD					
	3 104 51 3 104 52	3 104 53	3 104 54	3 104 55	3 104 56	3 104 57
<b>GENERAL FEATURES</b>						
Nominal Power (kVA)	20	40	60	80	100	120
Active power (W)	18	36	54	72	90	108
Module Power (kVA)	6.7 for the Power Module (20kVA with 3 Modules), power factor 0.9					
Technology	On-Line Double Conversion VFI-SS-111					
System	Modular, expandable and redundant UPS system in just one 19" rack cabinet					
Hot Swap capacity	Possibility of replacing the power modules and/or battery without turning off the UPS					
<b>INPUT FEATURES</b>						
Input voltage	230V 1F+N, 400V 3F+N			400V 3F+N		
Input frequency	50-60 Hz ±2% Autosensing					
Input Voltage Range	230V +15%/-20% 1F 400V +15%/-20% 3F			400V +15%/-20% 3F		
THD Input Current	<3%					
Compatibility with Power-Supply Units	Synchronism between the IN/OUT frequencies that can be configured for wider frequency ranges, ±14%					
Input Power Factor	> 0,99 from 20% of the load					
<b>OUTPUT FEATURES</b>						
Output voltage	230V 1F, 400V 3F			400V 3F		
Performance at Full Load	Up to 95%					
Nominal output frequency	50/60 Hz ±0.1					
Crest Factor	3.5:1					
Output Voltage Tolerance	±1%					
Allowed Overload	10 minutes at 125% and 60 seconds at 150%					
Performance in Eco Mode	99%					
Bypass	Automatic and maintenance bypass					
<b>BATTERIES</b>						
Battery Module	The battery modules are designed to easily be fitted inside the cabinet					
Battery Series Type/Voltage	VRLA - AGM / 252 Vdc					
Back-Up Time	Configurable and expandable both internally and with additional battery cabinets					
Battery Charge	Smart Charge technology. 3-stage advanced cycle					
<b>COMMUNICATION AND MANAGEMENT</b>						
Display and Signals	4 rows/20 characters, 4 buttons to browse the menus, multi-colour LED status indicator					
Communication Ports	2 RS232 serial ports, 1 Logical port, 5 ports with dry contacts, 2 slots for SNMP interfaces					
Emergency Power Off (EPO)	Yes					
Remote Management	Available					
<b>PHYSICAL FEATURES</b>						
Dimensions (H x L x D) (mm)	2080 /570 /912 (42U)					
Installed Power Modules	3	6	9	12	15	18
Installable Battery Slots	Up to 30	Up to 24	Up to 18	-	-	-
Net Weight (kg)	205	240	276	272	318	364
<b>ENVIRONMENTAL CONDITIONS</b>						
Operating Temperature/Humidity	0 - 40 °C / 20 - 80% non-condensing					
Maximum Audible Noise at 1 m (dBA)	50÷65					
Heat Loss (BTU/h)	2730	5460	8190	10920	13650	16380
<b>CONFORMITY</b>						
Certifications	EN 62040-1, EN 62040-2, EN 62040-3					
<b>SERVICES</b>						
Installation	Can be performed by the user, modular architecture with "plug and play" power and battery modules					
Maintenance	Can be performed by the user, optional services available from the manufacturer					
Diagnostics	-					



TRIMOD						
Trimod10	Trimod15	Trimod20	Trimod30	Trimod40	Trimod60	
10	15	20	30	40	60	
9	13,5	18	27	36	54	
3.4	5	6.7	5	6.7	6.7	
On-Line Double Conversion VFI-SS-111						
Modular, expandable and redundant UPS						
230V 1F+N, 400V 3F+N				400V 3F + Neutral		
50-60 Hz $\pm 2\%$ Autosensing						
400 V $+15\%/-20\%$ - 230 V $+15\%/-20\%$				400 V $+15\%/-20\%$		
$< 3\%$						
Synchronism between the IN/OUT frequencies that can be configured for wider frequency ranges, $\pm 14\%$						
$> 0,99$ from 20% of the load						
230V 1F+N, 400V 3F+N				400V 3F + Neutral		
Up to 95%						
50/60 Hz can be selected by the user $\pm 1$ Hz						
3.5:1						
$\pm 1\%$						
10 minutes at 125% and 60 seconds at 150%						
99%						
Automatic and maintenance bypass						
The battery modules are designed to easily be fitted inside the cabinet						
VRLA - AGM / 240 Vdc (internal redundant series)						
Configurable and expandable both internally and with additional battery cabinets						
Smart Charge technology, 3-stage advanced cycle						
4 rows/20 characters, 4 browsing buttons, multi-colour LED status indicator, alarms and audio signals						
2 RS232 serial ports, 1 Logical port, 4 ports with dry contacts, 1 slots for interfaces						
Yes						
Available						
1370 /414 /628						
3	3		6	6	9	
Up to 12	Up to 12					
120	120		130	130	150	
0 - 40 °C / 20 - 80%						
46						
1364	2183	2729	4094	6141	8189	
EN 62040-1, EN 62040-2, EN 62040-3						
Can be performed by the user, modular architecture with "plug and play" power and battery modules						
Can be performed by the user, optional services available from the manufacturer						
Advanced diagnostics functions via the display						

# UPS technical features (continued)

## WHAD, Daker DK, DHEA, CONVENTIONAL SINGLE-PHASE UPS SYSTEMS

ITEM	WHAD									
	3 100 87 3 100 88	3 100 90 3 100 91	3 100 93 3 100 94	3 100 96	3 100 97	3 100 98	3 100 99	3 101 00	3 101 01	
<b>GENERAL FEATURES</b>	<b>TOWER</b>									
Nominal power (VA)	800	1000	1500	2000	2500	3000	4000	5000	6000	
Active power (W)	560	700	1050	1400	1750	2100	2800	3500	4200	
Technology	On-Line Double Conversion VFI-SS-111									
Waveform	Sinusoidal									
UPS architecture	Conventional UPS systems with expandable uptime									
<b>INPUT</b>										
Input voltage	230 V									
Input frequency	50-60 Hz ±2% Autosensing									
Input Voltage Range	184V±265V at 100% of the load									
THD Input current	3%									
Input power factor	>0,99									
Compatibility with Power-Supply Units										
<b>OUTPUT</b>										
Output voltage	230V ± 1%									
Output frequency (nominal)	50/60 Hz synchronised									
Crest Factor	3.5: 1									
THD Output voltage	1%									
Allowed Overload	300% for 1 sec., 200% for 5 sec., 150% for 30 sec.									
Bypass	Electromechanical, automatic and internally synchronised (due to overload or operating fault)									
<b>BATTERIES</b>										
Uptime Expansion	Yes					No				
Battery series voltage (VRLA-AGM)	48Vdc			36Vdc		144Vdc			192Vdc	
Number of batteries										
Back-Up Time (min)	24	18	10	13	10	23	14	16	12	
<b>COMMUNICATION AND MANAGEMENT</b>										
Display and Signals	LED multi-colour status indicator, alarms and audio signals									
Communication Ports	1 RS232 serial port					1 RS232 serial port, 1 logical port, 1 slot for the network interface connection				
Remote Management	available									
Network interface slot										
Output socket										
<b>MECHANICAL FEATURES</b>										
Dimensions H x L x D (mm)	355 x 88 x 390			460 x 160 x 425			475 x 270 x 570			
Dimensions H x L x D (mm) Battery Cabinet	319 x 160 x 402			319 x 160 x 402			319 x 160 x 402			
Net Weight (kg)	12			23		55		65		
<b>ENVIRONMENTAL CONDITIONS</b>										
Operating temperature (°C)	0÷40									
Relative humidity (%)	20÷80 non-condensing									
Noise level at 1 m (dBA)	< 40			< 42			< 40			
Heat Loss (BTU/h)	150	190	287	380	478	570	760	952	1140	
<b>CERTIFICATIONS</b>										
Standards	EN 62040-1, EN 62040-2, EN 62040-3									



Daker DK									DHEA	
3 100 50	3 100 51	3 100 52	3 100 53	3 100 56	3 100 54	3 100 57	3 100 58	3 101 07	3 101 08	
1000	2000	3000	4500	6000	10000			1000	1500	
800	1600	2400	4050	5400	9000			700	1050	
On-Line Double Conversion VFI-SS-111									On-Line Double Conversion VFI-SS-111	
sinusoidal									sinusoidal	
convertible tower and rack									energy station	
230 V									230 V	
50/60 Hz ± 5% (autosensing)									50/60 Hz ± 2%	
160 V ÷ 288 V									184 V ÷ 265 V	
< 3%									< 3%	
> 0.99									> 0,99 from 20% of the load	
Synchronization configuration between IN/OUT frequencies for wider ranges, ± 14%										
230 V ± 1%									230 V ± 1%	
50/60 Hz ± 0.1% can be set from the LCD panel									50/60 Hz ± 1%	
3:1										
< 3% (with linear load)									< 1%	
Automatic and maintenance bypass										
Yes										
12 V 7.2 Ah	12 V 7.2 Ah	12 V 9 Ah	12 V 5 Ah		12 V 5 Ah	-	-	36 V 7.2 Ah		
3	6	6	20	-	20	-	-	2		
10	10	8	6	-	4	-	-			
4 buttons and 4 LEDs to monitor the status of the UPS.										
RS232 and USB serial ports			RS232 serial ports						1 RS 232 + 3 contact outputs (2 poles) + EPO	
available										
SNMP										
									1	3
440x88 x405	440x88 x650	440x88 x650	440x176 x680	440x88 x650	440x176 x680	440x88 x650	440x132x680	450X309X170 (inverter)		
440x176 x405	440x88 x650	440x88 x650	-	440x132 x680	-	440x132 x680	440x132 x680	450X125X170 (batteries)		
16	29.5	30	60	25*	60	25*	26*	20		
0 - 40 °C										
20÷80 % non-condensing										
< 50									< 40	
490	654	818	982	1310	1636					
EN 62040-1, EN 62040-2, EN 62040-3										

\* Weight without battery

# UPS range

The UPS range comprises a wide variety of solutions to meet any installation requirement. From the higher performance machines, such as ARCHIMOD, to entry-level UPS systems, there is the right solution for every application field, from Data Centres to home-based computer work stations.

## MODULAR, CONVENTIONAL AND LINE-INTERACTIVE UPS SYSTEMS

P (VA)	TRIMOD	Uptime (min)	P (VA)	ARCHIMOD	MEGALINE			
					Single cabinet	Double cabinet	Rack	
10	3 103 99	11						
	3 104 00	17						
	3 104 01	35	600					
	3 104 00 + 3 107 57	54	800					
	3 104 00 + 3 107 58	68	1000					
15	3 104 05	13	1100					
	3 104 06	21	1250		3 103 50		3 103 79	
	3 104 06 + 3 107 60	33	1500					
	3 104 06 + 3 107 63	57	2000					
	3 104 04 + 3 108 08	110*	2500		3 103 52		3 103 81	
20	3 104 11	9	3000					
	3 104 12	14	3750		3 103 54		3 103 83	
	3 104 12 + 3 107 62	35	4000					
	3 104 10 + 3 108 08	82*	4500					
	3 104 12 + 3 107 63 + 3 107 62	59	5000		3 103 56	3 103 60 + 3 107 78	3 103 85	
30	3 104 16 + 3 107 57	6	6000					
	3 104 16 + 3 107 63	12	6250			3 103 63 + 3 107 79		
	3 104 16 + 3 108 09	50*	7500			3 103 66 + 3 107 80		
	3 104 16 + 3 108 09 (X2)	110*	8000					
40	3 104 21 + 3 107 63	8	8250			3 103 69 + 3 107 81		
	3 104 21 + 3 107 58 (X2)	16	<b>P (kVA)</b>					
	3 104 21 + 3 108 10	33*	10			3 103 72 + 3 107 82		
	3 104 21 + 3 107 59 (X3)	38	15					
	3 104 21 + 3 107 64 (X4)	60	16					
	3 104 21 + 3 108 10 (X2)	82*	20	3 104 51 (1)				
	3 104 21 + 3 108 10 (X3)	120*	20	3 104 52				
60	3 104 28 + 3 107 58 (X2)	9	40	3 104 53				
	3 104 28 + 3 107 64 (X2)	14	45					
	3 104 28 + 3 108 11	17*	60	3 104 54				
	3 104 28 + 3 107 63 (X4)	27	80	3 104 55				
	3 104 28 + 3 108 11 (X2)	50*	100	3 104 56				
	3 104 28 + 3 108 11 (X3)	80*	120	3 104 57				
	3 104 28 + 3 108 11 (X4)	110*						

\*Configurations with battery cabinets (20 x 94 Ah).

(1) with 18 rack units available

Battery cabinet dimensions and weight:

A x L x P 1635 x 600 x 800 (mm), 785 kg





FOLLOW US ALSO ON

[www.ecataleg.be](http://www.ecataleg.be)

[www.ups.legrand.com](http://www.ups.legrand.com)



Legrand Group Belgium nv  
Kouterveldstraat 9  
1831 Diegem  
Tel.: +32 (0)2 719 17 11  
Fax: +32 (0)2 719 17 00  
E-mail: [info.be@legrandgroup.be](mailto:info.be@legrandgroup.be)