

SAMPLE SPECIFICATIONS (Current ANSI/AWWA revisions apply)

4" through 24" Push-On joint ductile iron fittings shall be produced in accordance with all applicable terms and provisions of ANSI/AWWA C153/A21.53. Fittings are cement-lined and seal-coated in accordance with ANSI/AWWA C104/A21.4. Joints shall be in accordance with manufacturer's design with bell sockets designed to receive pressure pipe O.D.'s as specified in ANSI/AWWA C151/A21.51 and AWWA C900 TABLE 2. The working pressure rating shall be 350 PSI, except for wyes and flanged-branch fittings. NOTE: Fittings are cement lined and seal coated in accordance with ANSI/AWWA C104/A21.4, also available bare or epoxy coated. Double cement lined available. Coated and/or lined fittings meet NSF-61, NSF-372 and Annex G.

Thicknesses and dimensions of bell sockets and gaskets shall be in accordance with the manufacturer's design. Gaskets shall be furnished by the manufacturer. Working pressures apply to fittings only and do not apply to restraining lugs or external restraining devices. Installation of fittings shall be per AWWA C600 and AWWA C651.

NOTE: Standard restraining lugs are provided on sizes 4" through 16" ONLY. Restraining lugs are available on 18"-24" fittings provided sufficient time is available to make tooling adaptations.

EXCEPTIONS: Union-Tite fittings with flanged branches are rated for water pressure of 250 PSI but can be rated for 350 PSI with the use of an annular ring or comparable gasket. Wye fittings over 12" are not pressure rated, call Tyler Union for information.

ADVANTAGES AND FEATURES

- Push-on gasket joint uses TYTON® or McWane 350 Sure Stop® gaskets
- For use with Ductile iron pipe, C-900/905 PVC pipe, and 4"-12" pressure rated IPS diameter PVC pipe (with transition gasket)
- Deep stab joint design accommodates taper on plastic pipes
- Slip joint installation eliminates T-bolts and nuts (MJ glands not needed)

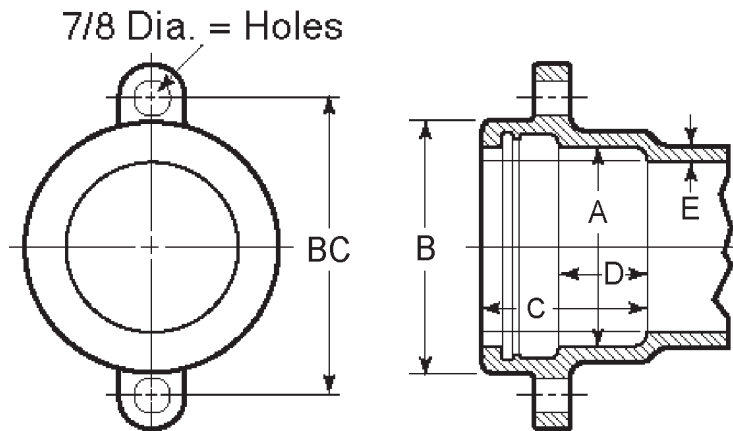

BELL DIMENSIONS IN INCHES FOR UNION-TITE FITTINGS

Pipe Size	A	B	B.C.	C	D	E
4	5.04	6.38	7.88	4.16	2.25	.35
6	7.14	8.52	10.50	4.29	2.25	.37
8	9.32	10.90	12.88	4.78	2.25	.39
10	11.37	12.91	14.69	4.98	2.25	.41
12	13.47	15.12	17.19	4.98	2.25	.43
14	15.64	18.12	19.00	5.40	2.25	.51
16	17.74	20.32	21.40	5.40	2.25	.52
18	19.83	22.52	...	5.40	2.25	.59
20	21.94	24.29	...	5.40	2.25	.60
24	26.14	29.14	...	5.65	2.50	.62

TYTON® is a registered trademark of U.S. Pipe and Foundry Company.

For Joint deflection, refer to Tyler Union product submittal 26U located on page 65 of this catalog.

NOTE: The fitting laying lengths provided are approximate, contact Tyler Union Waterworks for the laying length of a specific fitting.



UNION-TITE DUCTILE IRON C153 COMPACT FITTINGS

Sizes 4"-12" UL Listed for Fire Main Equipment

BENDS

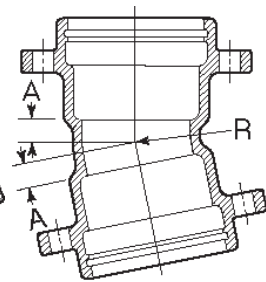
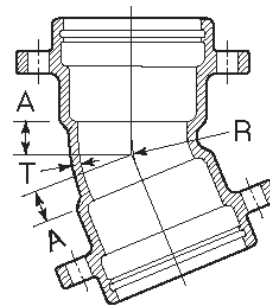
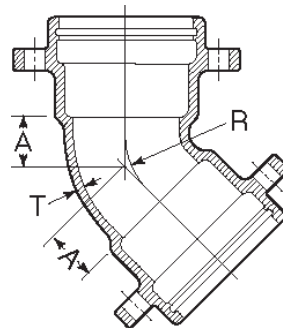
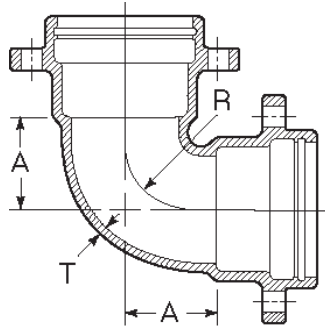

90° (1/4) UT Bends

45° (1/8) UT Bends

22½° (1/16) UT Bends

11¼° (1/32) UT Bends

Size	Dimensions				Weight	Size	Dimensions			Weight	Size	Dimensions			Weight		
	T	A	R				A	R				A	R			A	R
4	.35	4.5	3.87		24	2.0	3.31		26	1.50	4.38		18	1.25	6.77		18
6	.37	6.0	5.37		51	3.0	5.72		42	2.25	8.16		39	1.50	9.38		40
8	.39	7.0	6.37		80	3.5	6.93		66	2.50	9.40		64	1.75	11.48		60
10	.41	9.0	8.36		121	4.5	9.34		101	3.00	13.17		67	2.00	13.95		77
12	.43	10.0	9.36		151	5.5	11.75		128	3.50	14.42		111	2.25	16.50		94
14	.51	12.0	10.98		254	5.5	10.85		143	3.75	13.82		162	2.60	14.26		113
16	.52	13.0	12.00		328	6.0	12.02		225	4.00	14.97		195	2.60	15.23		172
18	.59	15.5	14.00		482	6.5	12.36		209	7.50	30.19		209	3.00	60.94		209
20	.60	17.0	15.50		340	7.0	13.59		397	8.50	35.19		414	3.50	71.07		265
24	.62	17.0	15.59		674	7.5	14.69		492	9.00	37.69		596

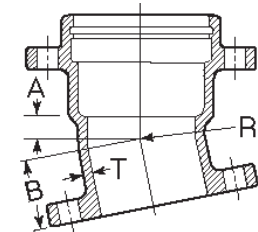
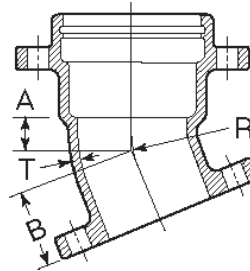
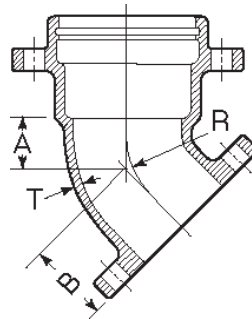
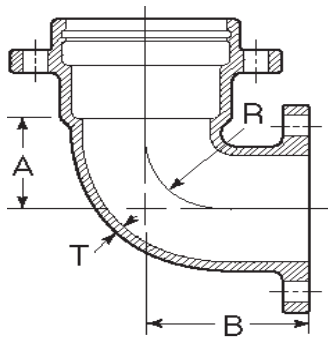

**90° (1/4)
UT x Flange Bends**

**45° (1/8)
UT x Flange Bends**

**22½° (1/16)
UT x Flange Bends**

**11¼° (1/32)
UT x Flange Bends**

Size	T	Dimensions				Weight	Size	T	Dimensions				Weight	Size	T	Dimensions				Weight	
		A	B	R					A	B	R					A	B	R			A
4	.35	4.5	6.5	3.87		31	2.0	4.0	3.31		21	1.50	3.5	4.38		25	1.25	3.30	6.77		24
6	.37	6.0	7.0	5.37		49	3.0	5.0	5.72		42	2.25	4.3	8.16		44	1.50	3.50	9.38		30
8	.39	7.0	9.0	6.37		74	3.5	5.5	6.93		60	2.50	4.5	9.40		64	1.75	3.75	11.48		61
10	.41	9.0	10.0	8.36		130	4.5	6.5	9.34		93	3.00	5.3	13.17		90	2.00	4.00	13.95		80
12	.43	10.0	12.0	9.36		158	5.5	7.5	11.75		122	3.50	5.5	14.42		112	2.25	4.30	16.50		94
14	.51	12.0	15.5	10.98		231	5.5	8.5	10.85		162	3.75	6.8	13.82		174	2.60	5.75	14.26		170
16	.52	13.0	16.5	12.00		233	6.0	9.5	12.02		275	4.00	7.5	14.97		228	2.60	6.10	15.23		228

NOTE: The fitting laying lengths provided are approximate, contact Tyler Union Waterworks for the laying length of a specific fitting.



**UNION-TITE DUCTILE IRON
C153 COMPACT FITTINGS**

BENDS

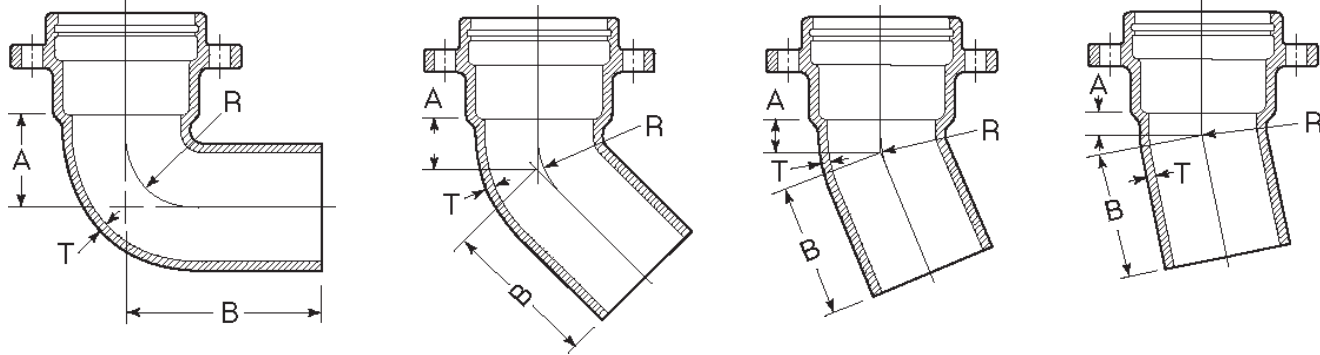

**90° (1/4)
UT x PE Bends**

**45° (1/8)
UT x PE Bends**

**22 1/2° (1/16)
UT x PE Bends**

**11 1/4° (1/32)
UT x PE Bends**

Size	T	Dimensions				Weight	Dimensions				Weight	Dimensions				Weight	
		A	B	R			A	B	R			A	B	R			
4	.35	4.5	10.5	3.87	35	2.0	8.0	3.31	21
6	.37	6.0	12.0	5.37	70	3.0	9.0	5.72	38	2.25	8.08	8.16	35	1.50	7.30	9.38	36
8	.39	3.5	9.5	6.93	60	2.50	8.34	9.40	57	1.75	7.55	11.48	55

TEES

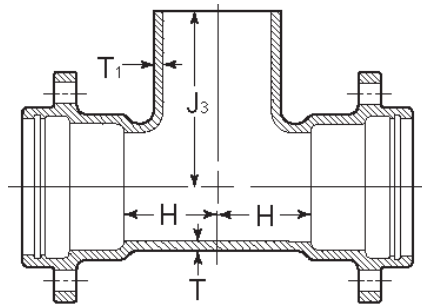

UT x UT x PE Tees

Size	Run	Branch	T	Dimensions			Weight
				T1	H	J3	
6	6	6	.37	.37	6.0	11.5	60
8	6	6	.39	.37	6.0	12.5	80
12	6	6	.43	.37	7.0	15.5	140

NOTE: The fitting laying lengths provided are approximate, contact Tyler Union Waterworks for the laying length of a specific fitting.



UNION-TITE DUCTILE IRON C153 COMPACT FITTINGS

TEES

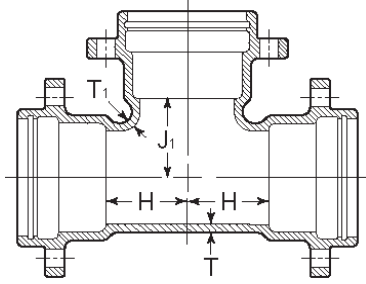

UT x UT Tees

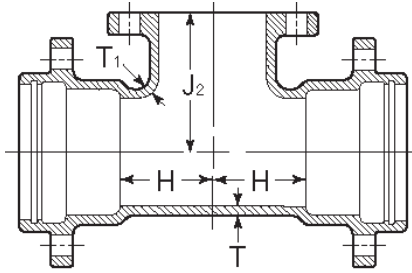

UT x Flange Tees

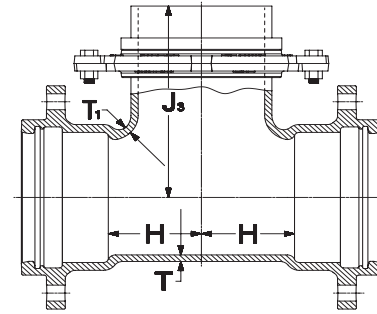

UT x Swivel Tees

Size	Dimensions						Weights		
	T	T1	H	J1	J2	J3	UT x UT	UT x Flange	UT x Swivel
4	.35	.35	4.5	4.5	6.5	...	44	45	...
6x4	.37	.35	5.0	6.0	8.0	...	68	56	...
6	.37	.37	6.0	6.0	8.0	9.5	69	71	65
8x4	.39	.35	5.0	7.0	9.0	...	73	89	...
8x6	.39	.37	6.0	7.0	9.0	10.5	96	101	100
8	.39	.39	7.0	7.0	9.0	10.5	116	117	110
10x4	.41	.35	6.0	9.0	11.0	...	102	115	...
10x6	.41	.37	7.0	9.0	11.0	12.5	113	128	130
10x8	.41	.39	8.0	9.0	11.0	12.5	145	145	156
10	.41	.41	9.0	9.0	11.0	...	155	158	...
12x4	.43	.35	6.0	10.0	12.0	...	119	138	...
12x6	.43	.37	7.0	10.0	12.0	13.5	141	148	162
12x8	.43	.39	8.0	10.0	12.0	13.5	177	170	158
12x10	.43	.41	9.0	10.0	12.0	...	160	162	...
12	.43	.43	10.0	10.0	12.0	...	217	183	...
14x6	.51	.44	6.5	10.5	12.5	14.0	176	212	202
14x10	.51	.46	8.5	10.5	12.5	...	195	246	...
14x12	.51	.47	9.5	10.5	12.5	...	196	296	...
14	.51	.51	10.5	10.5	14.0	...	209	321	...
16x6	.52	.45	6.5	11.5	13.5	15.0	266	160	229
16x8	.52	.46	7.5	11.5	13.5	15.0	292	270	292
16x10	.52	.47	8.5	11.5	13.5	...	232	330	...
16x12	.52	.48	9.5	11.5	13.5	...	239	321	...
16x14	.52	.51	10.5	11.5	15.0	...	349	342	...
16	.52	.52	11.5	11.5	15.0	...	261	355	...
18x6	.59	.44	6.5	12.5	14.5	16.13	348	301	348
18x8	.59	.45	7.5	12.5	14.5	16.13	325	319	324
18x10	.59	.47	8.5	12.5	14.5	...	344	337	...
18x14	.59	.56	10.5	12.5	16.0	...	342	393	...
18x16	.59	.57	11.5	12.5	16.0	...	362	420	...
20x6	.60	.44	7.0	14.0	16.0	17.5	355	341	400
20x10	.60	.47	9.0	14.0	16.0	...	369	420	...
20x14	.60	.56	11.0	14.0	17.5	...	484	474	...
20x16	.60	.57	12.0	14.0	17.5	...	610	498	...
20x18	.60	.59	13.0	14.0	17.5	...	539
24x6	.62	.44	7.0	16.0	18.0	19.5	385	512	525
24x10	.62	.47	9.0	16.0	18.0	...	478	468	...
24x12	.62	.49	10.0	16.0	18.0	...	663	503	...
24x14	.62	.56	11.0	16.0	19.5	...	542	531	...
24x16	.62	.57	12.0	16.0	19.5	...	566	555	...
24x18	.62	.59	13.0	16.0	593
24x20	.62	.60	15.0	17.0	628
24	.62	.62	17.0	17.0	884

NOTE: The fitting laying lengths provided are approximate, contact Tyler Union Waterworks for the laying length of a specific fitting.



UNION-TITE DUCTILE IRON C153 COMPACT FITTINGS

REDUCERS

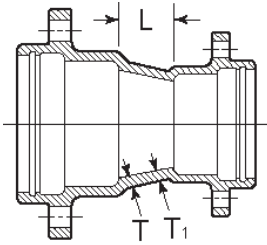

UT x UT Reducers

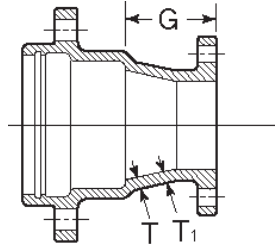

UT x Flange Reducers

Size	T	Dimensions			Weights	
		T1	L	G	UT x UT	UT x Flange
6x4	.37	.35	4.0	6.0	32	32
8x4	.39	.35	5.0	7.0	46	46
8x6	.39	.37	4.0	6.0	49	47
10x4	.41	.35	7.0	9.0	47	55
10x6	.41	.37	5.0	7.0	47	59
10x8	.41	.39	4.0	6.0	53	61
12x4	.43	.35	9.0	11.0	74	78
12x6	.43	.37	7.0	9.0	58	75
12x8	.43	.39	5.0	7.0	74	74
12x10	.43	.41	4.0	6.0	82	95
14x6	.51	.44	9.0	11.0	84	121
14x8	.51	.45	7.0	9.0	85	128
14x10	.51	.46	5.0	7.0	87	127
14x12	.51	.47	4.0	6.0	104	144
16x6	.52	.45	11.0	13.0	94	133
16x8	.52	.46	9.0	11.0	104	141
16x10	.52	.47	7.0	9.0	130	158
16x12	.52	.48	5.0	7.0	152	172
16x14	.52	.51	4.0	6.0	139	196
18x8	.59	.45	14.0	16.0	142	157
18x10	.59	.47	12.0	14.0	151	175
18x12	.59	.49	10.0	12.0	167	215
18x14	.59	.56	8.0	11.5	217	234
18x16	.59	.57	7.0	10.5	202	246
20x10	.60	.47	14.0	16.0	180	234
20x12	.60	.49	12.0	...	205	...
20x14	.60	.56	10.0	13.5	233	249
20x16	.60	.57	8.0	11.5	250	272
20x18	.60	.59	7.0	...	248	...
24x12	.62	.49	16.0	18.0	246	262
24x14	.62	.56	14.0	17.5	281	315
24x16	.62	.57	12.0	15.5	380	328
24x18	.62	.59	10.0	...	390	...
24x20	.62	.60	8.0	...	421	...

UT x Flange Adaptor

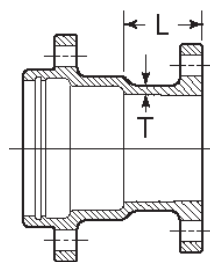

Size	Dimensions		Weight
	T	L	
4	.35	6.0	28
6	.37	6.0	36
8	.39	6.0	54
10	.41	6.0	71
12	.43	6.0	102
14	.51	7.0	113
16	.52	7.0	115
20	.60	6.0	295

TAPPED TEE/CROSS

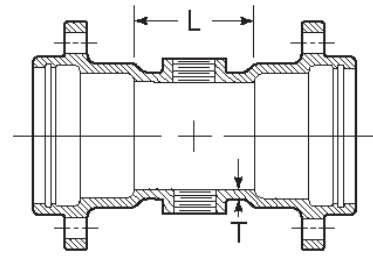
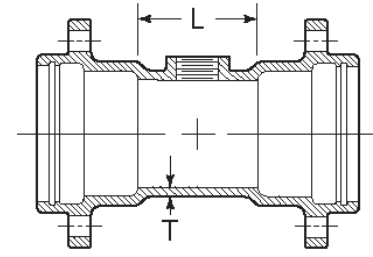

UT x Tapped Tee/Crosses

Size	T	Dimensions		Weight
		Max Tap	L	
4	.35	3.0	6.0	27
6	.37	3.5	6.0	38
8	.39	3.5	6.0	59
10	.41	3.5	6.0	72
12	.43	3.5	6.0	92

CAPS AND PLUGS

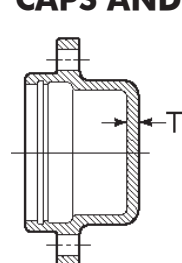

Solid Cap

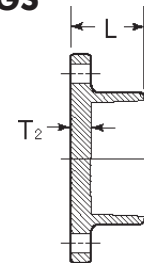

Solid Plug

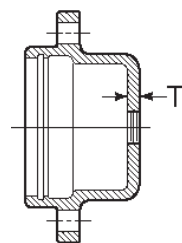

2" Tapt Cap

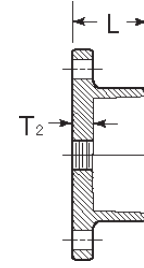

2" Tapt Plug

UT Caps and Plugs*

Size	T1	T2	Dimensions		Weights	
			L	Cap	Plug	
4	.48	.50	5.25	15	8	
6	.48	.50	5.25	20	23	
8	.51	.53	5.25	35	32	
10	.53	.56	5.25	50	38	
12	.55	.62	5.25	75	49	

*Restraining lugs (ears) available.

NOTE: The fitting laying lengths provided are approximate, contact Tyler Union Waterworks for the laying length of a specific fitting.



UNION-TITE DUCTILE IRON C153 COMPACT FITTINGS

WYES

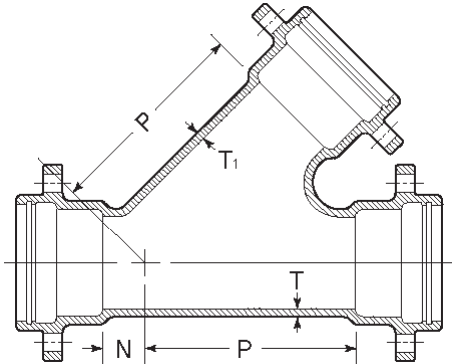

UT Wyes

Size	T	Dimensions			Weights
		T1	P	N	
8x4	.39	.35	13.5	0.0	89
10x4	.41	.35	15.0	0.0	141
10x6	.41	.37	16.0	1.0	151
10x8	.41	.39	17.0	2.5	175
10	.41	.41	18.0	4.0	200
12x4	.43	.35	16.5	0.0	178
12x6	.43	.37	18.5	1.5	201
12x8	.43	.39	18.5	1.5	224
12x10	.43	.41	20.0	3.0	240
12	.43	.43	20.0	5.0	289
14x6	.51	.44	19.5	0.0	236
14x8	.51	.45	21.0	1.5	255
14x10	.51	.46	22.5	3.0	325
14	.51	.51	25.0	6.0	475
16x6	.52	.45	21.0	0.0	281
16x8	.52	.46	22.5	0.5	304
16x12	.52	.48	25.0	3.5	346
16	.52	.52	28.0	6.5	380

CROSSES

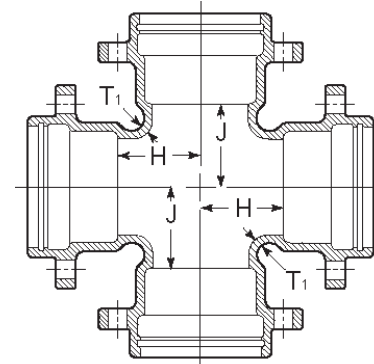

UT Crosses

Size	T1	Dimensions		Weights
		H	J	
6	.37	6.0	6.0	88
8x6	.37	6.0	7.0	117
8	.39	7.0	7.0	156
10x4	.35	6.0	9.0	116
12x8	.39	8.0	10.0	240
12	.43	10.0	10.0	241
14x6	.44	6.5	10.5	189
14x8	.45	7.5	10.5	204
14x10	.46	8.5	10.5	222
14x12	.47	9.5	10.5	239
14	.51	10.5	10.5	270
16x6	.45	6.5	11.5	234
16x8	.46	7.5	11.5	323
16x10	.47	8.5	11.5	268
16x12	.48	9.5	11.5	274
16x14	.51	10.5	11.5	322
16	.52	11.5	11.5	317

TYTON® GASKETS

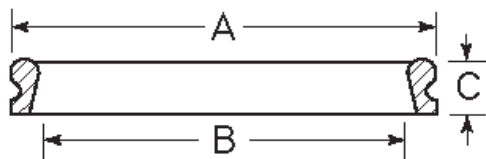

TYTON® JOINT IPS Transition and Regular Gasket

Size	Dimensions			
	A	Transition (IPS) B(±1%)	Regular (Ductile) B*	C
4	5.74	4.18	4.68	1.00
6	7.86	6.31	6.73	1.10
8	10.15	8.32	8.85	1.29
10	12.10	10.30	10.87	1.36
12	14.31	12.70	12.95	1.45

TYTON® is a registered trademark of U.S. Pipe and Foundry Company. for the laying length of a specific fitting.

NOTICE: Weights published in this catalog are for shipping purposes only. Actual weights may vary because some fittings are produced in both foundries. All fittings are made in the USA and meet the AWWA standards to which they are designed.

For weights of specific fittings, please contact your Tyler Union Waterworks representative.

NOTE: The fitting laying lengths provided are approximate, contact Tyler Union Waterworks for the laying length of a specific fitting.