

Constructional features – Types – Axial and Radial flux motors – Operating principles – Variable Reluctance Motors – Voltage and Torque Equations - Phasor diagram - performance characteristics – Applications.

1. INTRODUCTION

Synchronous Reluctance Motor

- * The name ‘Synchronous Reluctance Motor’ indicates, must rotate at synchronous speed.
- * It is a serious competitor to the induction machine in variable speed applications.
- * The synchronous reluctance motor is completely free of magnets and their operational problems.
- * It is inexpensive to make, and can operate at extremely high speeds and at higher temperatures than PM motors.
- * However, its power factor and efficiency are not as high as those of a PM motor, and the converter kVA requirement is higher.
- * It can operate from essentially standard p.w.m. a.c. inverters and has lower torque ripple.

1.1. SYNCHRONOUS RELUCTANCE MOTOR (SyRM) (or) SYNREL MOTOR

The PM synchronous motor operates as a synchronous reluctance motor, if the magnets are left out or demagnetized .i.e. the synchronous reluctance motors do not have any field winding or permanent magnet on the rotor. The rotor has salient poles but the stator has smooth, distributed poles. The synchronous reluctance machines are low-cost, rugged, have high-efficiency (ideally no rotor loss), and are capable of operating at very high speeds, at higher at higher temperatures than PM motors.

1.2. CONSTRUCTIONAL FEATURES

The synchronous-reluctance motor consists of two main parts,

- (a) Stator and
- (b) Rotor

a)Stator

The stator of the synchronous reluctance motor has smooth, distributed poles. It has a laminated iron core with open or semi closed uniformly distributed slots. The open slot configuration may' be used to house multiphase concentrated (single) coils per phase as shown in Fig.1.1

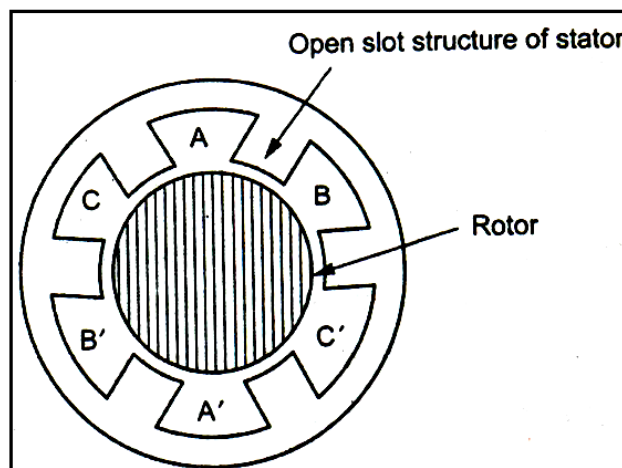

Figure. 1.1. Open slot stator structure of synchronous reluctance motor

This open slot structure allows for automated insertion of coils in the slots and may be used either for low power (or) two/three phase motors for higher torque. In this open slot structure, because of the presence of air gap field and considerable harmonics, significant torque pulsations occur which may not be tolerable in some drive applications.

In order to improve the performance, semi closed slots are used as shown in following Fig.1.2.

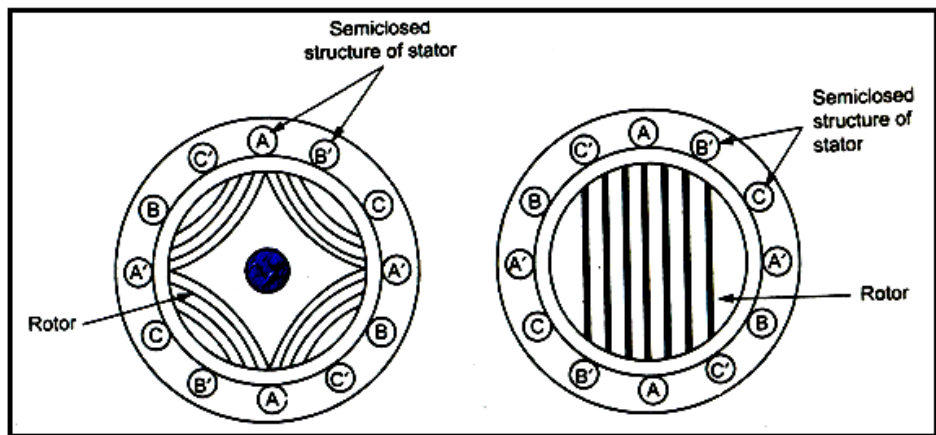

Figure. 1.2. Semi closed slot stator structures of synchronous reluctance motor

In general, the stator has multiple slots which are placed at an even pitch angle. Each slot is consisting of a stator winding for creating stator magnetic poles with a predetermined phase alternating current being supplied.

(b) Rotor:

The rotor of synchronous reluctance motor needs salient poles to create a variable reluctance in the motor's magnetic circuit which depends on the angular position of the rotor. These salient poles can be created by milling axial slots along the length of a squirrel cage rotor. The rotor of synchronous reluctance motor consists of plurality of pairs of slots. The slots may be at outer or inner.

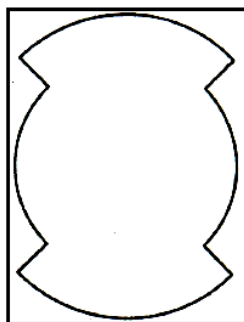

Figure. 1.3. Basic salient rotor structure of synchronous reluctance motor

The outer side slots are formed at an outer periphery and the inner slots are formed at inside of the rotor. The distance between the outer periphery of the rotor and the outer side slot is determined to be the width of the magnetic pole portion of the stator multiplied by 0.7 to 1.3. The first total magnetic flux amount of an outer permanent magnet disposed in the outer side slot is determined to be larger than or equal to the second total magnetic flux amount of an inner permanent magnet disposed in the inner side slot. To construct the rotor, a technique known as explosion bonding is applied. This explosion bonding technique uses explosive energy to force two or more metal sheets together at high pressures. The high pressure causes several atomic layers on the surface of each sheet to behave as a fluid.

The angle of collision between the two metals, forces this fluid to jet outward. Effectively cleaning the metal surface, these ultra clean surfaces along with the high pressure forcing the metal plates together provide the necessary condition for solid phase welding. Experimental tests on a stainless steel/mild steel bond indicate that the tensile and fatigue strengths of the bond -are greater than those of either of the

component materials due to the shock hardening which occurs during the process. The bond was also subjected to 10 cycles of temperature variation from 20^oc - 70^oc, with no significant reduction in tensile strength. The explosion bonding technique is shown in above Fig.1.4. There are some other joining techniques available such as brazing, roll bonding, or diffusion bonding which may also be appropriate for rotor construction.

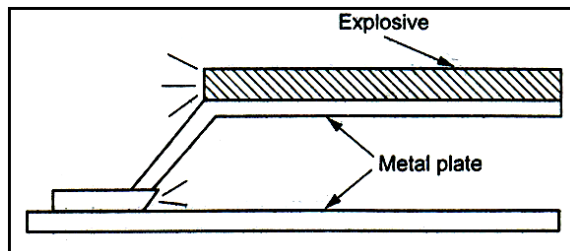

Figure. 1.4. Explosion bonding

First sheets of ferromagnetic and non-magnetic steel are bonded as shown in Fig.1.4. The bonded sheets are then cut into rectangular blocks which are machined into the desired rotor. The rotor shaft can also be machined out of the same block as the rotor.

1.3. TORQUE EQUATION

The idealized structure of a reluctance motor is the same as that of the salient pole synchronous machine except that the rotor does not have any field winding. In general, a three-phase machine can be represented by an equivalent two-phase machine as shown in following Fig.1.5 & Fig.1.6, where d^s - q^s correspond to stator direct and quadrature axes, and d^r - q^r correspond to rotor direct and quadrature axes.

Although this transformation is somewhat simple, to counter the problem of time-varying parameters (like time varying inductances) some effective transformation methodologies are formulated. In one such proposed methodology, both stator and rotor variables are transformed into a synchronously rotating reference frame that moves with the rotating magnetic field.

Another methodology proposes a transformation of stator variables to a rotating reference frame that is fixed on the rotor. Another proposed transformation shows the elimination of time-varying inductances by referring the stator and rotor variables to a common reference frame which may rotate at any speed (arbitrary reference frame).

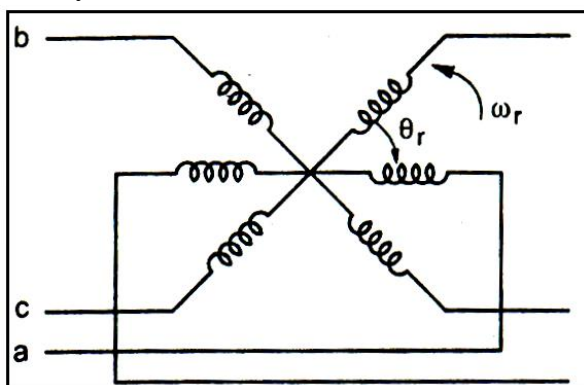

Figure. 1.5. Coupling effect in three-phase stator and rotor windings of motor

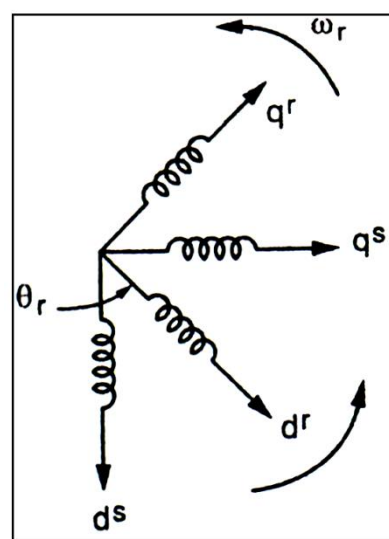
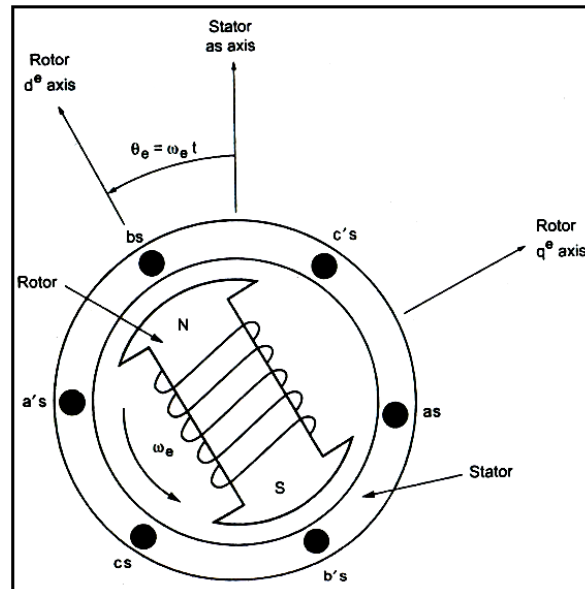

Figure. 1.6. Equivalent two-phase machine

1.4 .TORQUE EQUATION OF SALIENT POLE SYNCHRONOUS MACHINE

Derivation of the torque equation, we have to develop a dynamic machine model in which the three-phase stationary reference frame ($as-bs-cs$) variables are transformed into two-phase stationary reference frame ($d^s - q^s$) variables and then transforming these to synchronously rotating reference frame ($d^e - q^e$). The Fig.1.7 shows an idealized three-phase, two pole wound field synchronous machine. The d.c. field current is supplied to the rotor from a static rectifier through slip rings and brushes. (but in synchronous reluctance motor, the rotor does not have any field winding. Let us first develop the torque equation of salient pole synchronous machine, then let us modify the same for synchronous reluctance machine. Here, we have to remember that the rotor of synchronous reluctance motor has salient poles, so we have to consider only the development of torque equation of salient poles synchronous machine and not non salient pole machine). Since the rotor always moves at synchronous speed (ie., the slip is zero), the synchronous rotating ($d^e - q^e$) axes are fixed with the rotor, where the d^e axis corresponds to the north pole, as shown in Fig.1.7.



The difference in the characteristics of a salient pole machine from those of a normal salient pole machine is due to the non uniform air gap reluctances in the d^e and q^e axes. The resulting asymmetry in the direct and quadrature axes magnetizing reactances causes the corresponding synchronous reactances to be unsymmetrical.

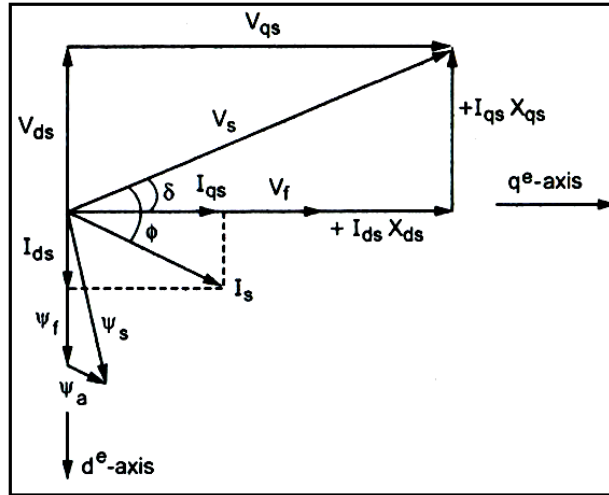

Figure. 1.8. Phasor diagram of salient pole synchronous machine in motoring mode

The following Fig.1.8 shows the, phasor diagram of a salient pole synchronous machine for the motoring mode which includes the flux linkages. Here, for simplicity, the stator resistance has been dropped.

The excitation or speed emf V_f is shown aligned with the q^e axes, whereas Ψ_f is the flux linkage induced by the field-current (I_f) is aligned with the d^e axes. The phase voltage (V_s) and phase current (I_s) are resolved into corresponding d^e and q^e components, and a voltage phasor diagram is drawn with the corresponding reactive drops. In the phasor diagram, the armature reaction flux Ψ_a aids the field flux to result in the stator flux Ψ_s as shown. In this motoring, mode phasor diagram, which is drawn or lagging power factor, $\Psi_s > \Psi_f$ [In case of generating mode $\Psi_s < \Psi_f$ because it is operating at leading power factor]. The power input to the machine is,

$$P_i = 3 V_s I_s \cos \Phi$$

From the phase diagram of Fig.1. 8, we can write

$$I_s \cos \Phi = I_{qs} \cos \delta - I_{ds} \sin \delta$$

The Fig. 1. 8, can also be a vector diagram, if all the rms phasors are multiplied by the factor $\sqrt{2}$

Substituting the equation, the input power P_i can be given as,

$$P_i = 3 V_s (I_{qs} \cos \delta - I_{ds} \sin \delta) \dots (1.3)$$

From the phasor diagram we can write,

$$I_{ds} = \frac{V_s \cos \delta - V_f}{X_{ds}}, \quad I_{qs} = \frac{V_s \sin \delta}{X_{qs}}$$

Substituting the equations, the power input is,

$$\begin{aligned}
P_i &= 3V_s \frac{V_s \sin \delta}{X_{qs}} \cos \delta - \frac{V_s \cos \delta - V_f}{X_{ds}} \sin \delta \\
&= 3V_s \left[\frac{V_s \sin \delta \cos \delta}{X_{qs}} - \frac{V_s \sin \delta \cos \delta - V_f \sin \delta}{X_{ds}} \right] \\
&= 3V_s \left[\frac{V_s \sin \delta}{2X_{qs}} - \frac{V_s \sin 2\delta}{2X_{ds}} + \frac{V_f \sin \delta}{X_{ds}} \right] \\
&= \frac{3V_s^2 \sin 2\delta}{2X_{qs}} - \frac{3V_s^2 \sin 2\delta}{2X_{ds}} + \frac{3V_s V_f \sin \delta}{X_{ds}} \\
&= \frac{3V_s^2 X_{ds} \sin 2\delta - 3V_s^2 X_{qs} \sin 2\delta}{2X_{ds} X_{qs}} + \frac{3V_s V_f \sin \delta}{X_{ds}} \\
&= \frac{3V_s^2 (X_{ds} - X_{qs}) \sin 2\delta}{2X_{ds} X_{qs}} + \frac{3V_s V_f \sin \delta}{X_{ds}}
\end{aligned}$$

We can relate the power delivered to the shaft with the torque developed in the machine as,

$$P_s = \frac{2}{P} \omega_e T_e$$

If machine losses are ignored, the power input P_i is directly delivered to the shaft.

$$P_i = P_s = \frac{2}{P} \omega_e T_e$$

$$\text{so } P_i = \frac{2}{P} \omega_e T_e$$

when machine losses are ignored.

$$T_e = \left(\frac{P}{2} \right) \left(\frac{1}{\omega_e} \right) P_i$$

$$T_e = \left(\frac{P}{2} \right) \left(\frac{1}{\omega_e} \right) \left[\frac{3V_s V_f \sin \delta}{X_{ds}} + \frac{3V_s^2 (X_{ds} - X_{qs})}{2X_{ds} X_{qs}} \sin 2\delta \right]$$

$$T_e = 3 \left(\frac{P}{2} \right) \left(\frac{1}{\omega_e} \right) \left[\frac{V_s V_f \sin \delta}{X_{ds}} + \frac{V_s^2 (X_{ds} - X_{qs})}{2X_{ds} X_{qs}} \sin 2\delta \right]$$

If supply voltage to frequency ratio is constant then (Ψ_s) i.e. stator flux linkage I be constant. So the torque remains unchanged. The resistance drop is small and is then neglected. Neglecting R_s , the stator flux linkage,

$$\Psi_s = \left| \frac{V_s}{\omega_e} \right| \angle -\frac{\pi}{2}$$

Considering only magnitude,

$$V_s = \Psi_s \omega_e$$

$$\text{Similarly } V_f = \Psi_f \omega_e$$

Also, from the basics, the synchronous reactance X_s , can be expressed as,

$$\begin{aligned} X_s &= \omega_e L_s \\ X_{ds} &= \omega_e L_{ds} \\ X_{qs} &= \omega_e L_{qs} \end{aligned}$$

Substituting the equations

$$T_e = 3 \left(\frac{P}{2} \right) \left(\frac{1}{\omega_e} \right) \left[\frac{(\psi_s \omega_e)(\psi_f \omega_e)}{(\omega_e L_{ds})} \sin \delta + \psi_s^2 \omega_e^2 \left[\frac{\omega_e L_{ds} - \omega_e L_{qs}}{2\omega_e^2 L_{ds} L_{qs}} \right] \sin 2\delta \right]$$

$$T_e = 3 \left(\frac{P}{2} \right) \left[\frac{(\omega_e^2 \psi_s \psi_f)}{(\omega_e^2 L_{ds})} \sin \delta + \frac{\psi_s^2 \omega_e^2}{\omega_e} \left[\frac{\omega_e (L_{ds} - L_{qs})}{2\omega_e^2 L_{ds} L_{qs}} \right] \sin 2\delta \right]$$

$$T_e = 3 \left(\frac{P}{2} \right) \left[\frac{(\psi_s \psi_f)}{(L_{ds})} \sin \delta + \frac{\psi_s^2 (L_{ds} - L_{qs})}{2(L_{ds} L_{qs})} \sin 2\delta \right]$$

This equation gives the developed torque with torque angle δ for a salient pole synchronous machine. The first component of the equation is contributed by the field ψ_f . The second component is defined as reluctance torque, which arises due to rotor saliency (*i.e.*, $X_{ds} \neq X_{qs}$), where the rotor tends to align with the position of minimum reluctance and is not influenced by the field excitation.

1.4.1. Torque equation of Synchronous Reluctance motor

The Permanent magnet synchronous motor operates as a synchronous reluctance motor if the magnets are left or demagnetized. The developed torque equation for salient pole synchronous motor has been given by the expression. The equation consists of two components in which, the first component is due to the field. This component should be left out for obtaining the torque equation of synchronous reluctance motor. In the equation, the second component is defined as reluctance torque.

So the developed torque of the reluctance motor can be expressed as,

$$T_e = 3 \left(\frac{P}{2} \right) \left[\frac{\psi_s^2 (L_{ds} - L_{qs})}{(L_{ds})} \sin \delta + \frac{\psi_s^2 (L_{ds} - L_{qs})}{2(L_{ds} L_{qs})} \sin 2\delta \right]$$

where,

T_e = Developed torque of synchronous reluctance motor.

P = Number of poles.

Ψ = The flux linkage induced by the field current (I_f)

L_{ds} = Direct axis inductance with respect to synchronously rotating frame.

L_{qs} = Quadrature axis inductance with respect to synchronously rotating frame.

δ = Torque angle.

The synchronous reluctance machines are low-cost, rugged, have high efficiency (ideally no rotor loss), and are capable of operating at very high speeds. The traditional

SyRM has low saliency that is low L_{dm}/L_{qm} ratio, which gives poor torque density, low power factor and poor efficiency.

However, the recent development of SyRM by anisotropic construction has made a much higher L_{dm}/L_{qm} ratio possible, which has significantly improved torque density, power factor, and efficiency. Their application has grown recently, although there are only a few manufactures of this machine worldwide. Let us see the classification of the synchronous reluctance motor with the presence of anisotropic constructional structure.

1.5. TYPES OF SYNCHRONOUS RELUCTANCE MOTOR

1.5.1. CLASSIFICATION OF SYNCHRONOUS RELUCTANCE MOTOR ACCORDING TO ROTOR CONFIGURATION

- (i) Cage rotor synchronous reluctance motor for line start
- (ii) Cageless rotor synchronous reluctance motor for variable speed.

1.5.1.1. Cage rotors for line start

A line start cage rotor synchronous reluctance motor comprises, a single phase stator arranged at an inner circumferential surface of a motor body and on which main coil and a sub coil are wound; a magnet unit is free-rotatebly arranged along a inner circumferential surface of the stator in order to maintain an air gap with the stator and a cage rotor provided with a rotational shaft at centre in order to be a readable along an inner circumferential surface of the magnet unit. The cage bar located at the peripheral portion is provided with magnetic barriers to accommodate the same pole numbers as the magnet unit.

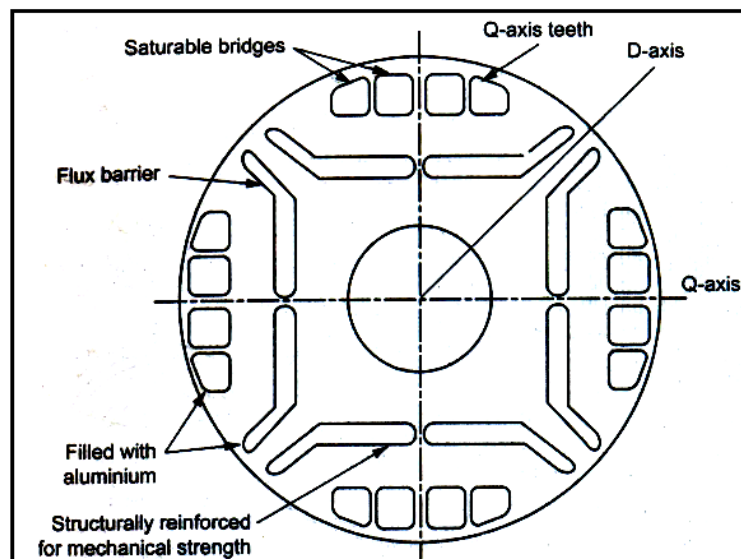

Figure. 1.9. Flux barrier type rotor

Distributed Anisotropy Cage-rotors

These rotors are used for line-start (constant voltage and frequency) applications. Fig.1.9 shows the flux-barrier rotor and may be built with conventional laminations (Fig.1.9(a),(b)), or with axial laminations (Fig.1.11(a),(b)). Here, we increase L_d/L_q to obtain both higher efficiency as well as power factor and to improve the starting self

synchronization performance more than that can be achieved by conventional salient pole or segmented solid-iron rotor (Fig.1.12).

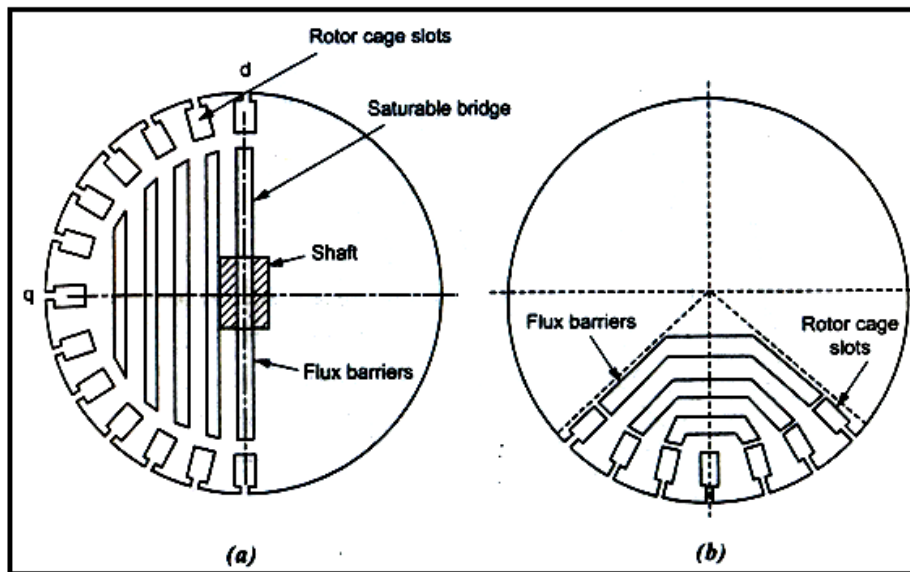

Figure. 1.10. Distributed anisotropy structures with conventional laminations

The rotor configuration built with stamped conventional laminations having a flux barrier below each closed (or semi closed) rotor slot with quickly saturable bridges provides a quadrature axis magnetizing inductance L_{qm} which sharply decreases with stator quadrature current (I_q) and has a small rotor-cage leakage inductance during asynchronous starting .

The rotor-cage slot area is reduced and high starting torque can be expected. Also as L_q decreases with load, the synchronous torque increases as it depends on $(L_d - L_q)$ [$\therefore T_e \propto L_{ds} - L_{qs}$ from equation and thus the high resistance leakage inductance rotor-cage produces sufficient asynchronous (damping) torque to secure an inherently stable reluctance motor. The uniform distribution of closed or semiclosed rotor slots can be expected to lower additional losses and lower noise.

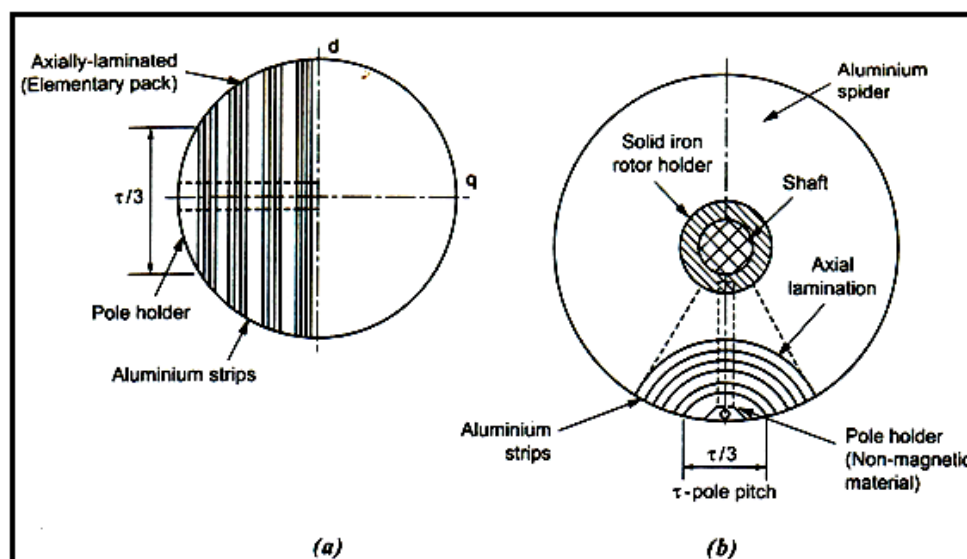

Figure. 1.11. Axially laminated anisotropic rotor structures

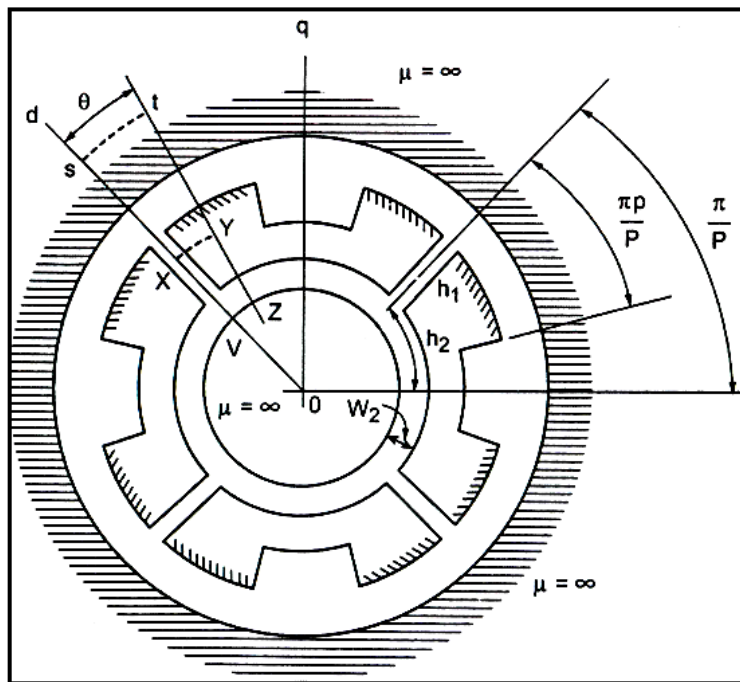

Figure. 1.12. Segment solid-iron rotor.

1.5.1.2. Distributed Anisotropy Cageless Motors

The cageless rotor structure of synchronous reluctance motor is used for variable speed applications. The Figs.1.13 and 1.14 depict this kind of construction.

For the conventional-lamination rotor, the saturable bridges are "moved" towards the airgap and the length is increased to produce an reluctance. In the two-pole configuration with two-end shafts, the conventional back iron is eliminated and thus the rotor diameter may be reduced to produce low inertia rotors. It is shown in the Fig.1.15

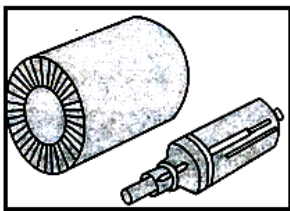

Figure. 1.13.

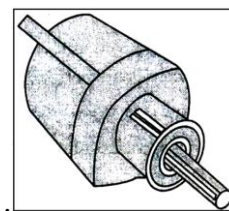

Figure. 1.14.

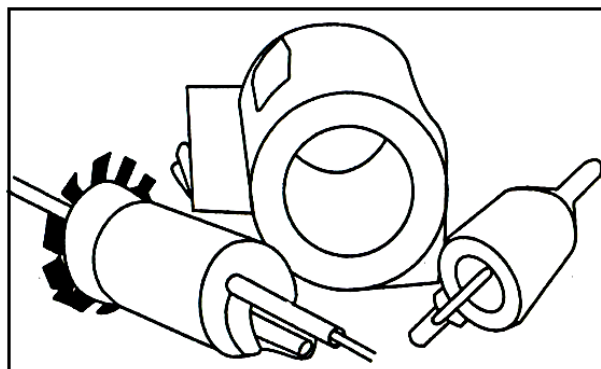

Figure. 1.15.

Instead of using the insulation spacers, ferrite permanent magnets may be used to decrease the field further in quadrature axis and to obtain a considerable constant power speed range.

1.5.2. CLASSIFICATION ACCORDING TO THE MAGNETIZATION OR LAMINATION OF THE ROTOR

In accordance with the variation in the airgap or magnetization, two types of construction are possible in synchronous reluctance motor. They are,

- (i) Axial air gap motor
- (ii) Radial air gap motor

The choice of the motor type depends on the requirement in applications. The axial air gap synchronous reluctance motor is axially laminated. Similarly the radial type motor is radially laminated. These motors have the same stator constructions as the multi phase induction motor. The axially laminated reluctance motors are designed to have high saliency in order to offer very good performance in terms of torque capacity, power factor and efficiency. The radially laminated reluctance motors which are also known as flux barrier type reluctance motors are designed to have optimized flux guide/flux barrier thickness ratio to produce less torque ripple and less iron losses.

1.5.2.1. Axial air gap motor

The Fig.1.16 shows the axially laminated rotor. The approach in this motor is to laminate the rotor in the axial direction. By increasing the ratio L_d / L_q motor power factor and efficiency can be increased. Higher L_d / L_q ratios are obtained with axial-lamination rotors. For a two pole, two phase axially laminated rotor with a L_d/L_q ratio of 20, we can get the maximum efficiency of 94%. For two pole rotors, with axial laminations, the shaft should be made either of two parts attached axially to the rotor core or it may go through (for conventional laminations) but, in this case, it should be of rectangular cross-section with grooves the quadrature axis magnetic reluctance high.

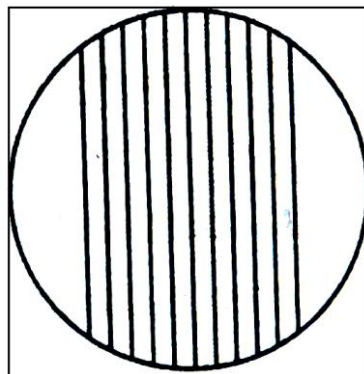

Figure. 1.16. Axially laminated rotor

In the Fig.1.11 (a),(b) packs of axial laminations are interleaved with aluminium sheets 0.2 mm thick with end rings to make an equivalent squirrel-cage rotor. The 0.2mm

aluminium sheet thickness is not high for motors in the tens and hundreds of kW and thus the noise level will be lower.

Another rotor design is shown in Fig.1.17. In this case, the rotor consists of alternating layers of ferromagnetic and non-magnetic steel. If the thickness of the steel is chosen such that the pitch of the ferromagnetic rotor segments matched the slot pitch of the stator, then regardless of the angle of rotation of the rotor, the ferromagnetic rotor segments always see a stator tooth pitch. This is done to minimize flux variations and hence iron losses in the rotor.

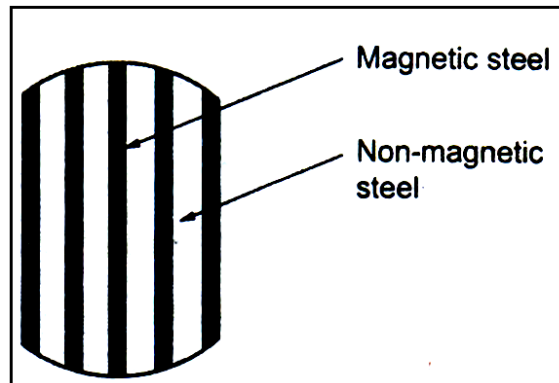

Figure. 1.17. Alternate rotor design of axial type motor

In reluctance motor, a reluctance torque is to be created on the rotor by the way of making the magnetic field induced in the rotor as a root cause to align the rotor with the stator field in a minimum reluctance position. The rotor has magnetic poles which have a low magnetic reluctance in an axial direction of the magnetic poles.

Also in order to align the rotor with the stator field in a minimum reluctance position to produce reluctance torque, it is better to have same number of reluctance path as the number of magnetic poles in the stator. Special laminations are done to make these equal numbers of reluctance path and magnetic poles. Synchronous speed is achieved as the salient poles lock in step with magnet poles of the rotating stator field and make it to run at the same speed as the rotating field.

The stator windings are similar to squirrel cage induction motor, as the synchronous reluctance motor is not self starting without the squirrel cage. During run up, it behaves as an, induction motor but as it approaches synchronous speed, the reluctance torque takes over and the motor locks into synchronous speed. The motor is pressure cast with end rings similar to induction motor.

1.5.2.2. Radially laminated rotor [Flux barrier type]

The rotor of radially laminated or flux barrier type synchronous reluctance motor comprises a rotational shaft. The rotor core which is formed as a plurality of steel plates are laminated to one another, the steel plate having a shaft hole for inserting the rotational shaft, a plurality of flux barrier groups spaced from one another in a circumferential direction and having a plurality of flux barriers spaced from one another in a radial direction.

A coupling hole is penetratingly formed between the adjacent two flux barrier groups and a coupling member inserted into the coupling hole and fixing the steel plate. Consequently, the fabrication cost and entire weight of the motor are decreased. The fabrication process is facilitated with a shortened fabrication time. Also, a large coupling intensity is obtained and a magnetic saturation does not occur, thereby preventing a functional

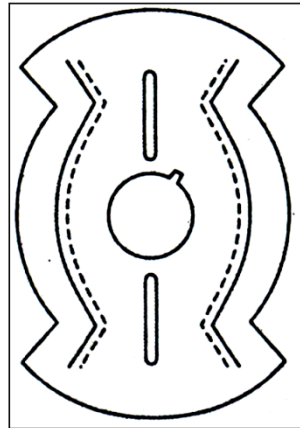

Figure. 1.18. Radially laminated rotor

degradation of the motor. The Fig.1.18 shows the radially laminated rotor of synchronous reluctance motor. For a four pole machine, the laminations are used with flux barriers punched into the steel as shown. The basic structure of this type of rotor will be as shown in Fig.1.19. It is having salient rotor shape and is such that the quadrature air gap is much larger than the direct air gap. This yields relatively small L_d/L_q ratios. The low L_d/L_q ratios are largely the result of circulating flux in the rotor pole faces.

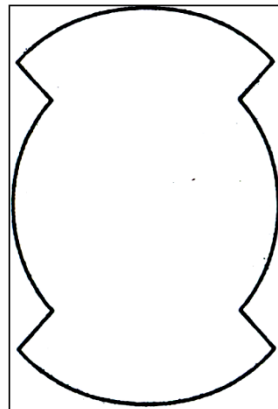

Figure. 1.19. Basic structure of radially laminated rotor of salient pole type

Eventhough the salient pole basic rotor structure shown in Fig.1.19 is good choice for high speed applications, the flux barriers and the central hole of the lamination required for the shaft weaken the rotor structurally and the radially laminated rotor shown in Fig1.18 is a poor choice for high speed applications

1.5.2.3. Low and High Magnetic Reluctances in Magnetic Circuits and their influences

The low or high values of magnetic reluctances have definite influence for the alignment of rotor with stator or revolving field, in turn for the operation of machine under consideration. When the spaces or notches between the rotor poles are opposite to the stator poles, the magnetic circuit of the motor has a high magnetic reluctance. But when the rotor poles are aligned with the stator poles, the magnetic circuit has a low magnetic reluctance. When a stator pole pair is energized, the nearest rotor pole pair will be pulled into alignment with the energized stator poles to minimize the reluctance path through the machine.

In synchronous reluctance motor, the rotor has magnetic poles which have a low magnetic reluctance in an axial direction of the magnetic poles, and high magnetic reluctance towards the circumference of the rotor. Hence the influence of magnetic reluctance in variable reluctance and synchronous

reluctance machines during their operations can be understood in following way. In a variable reluctance machine, when the stator winding is energized, the nearest rotor pole comes in alignment with the energized stator pole. When the stator and rotor pole axes are in alignment with each other, they are in minimum reluctance position. When the deviation in between the stator and rotor pole axes are maximum, that condition is known as maximum reluctance position.

The non-alignment between the stator and rotor poles is generally termed as variable reluctance position. In synchronous reluctance machine, when the stator is excited, the three phase symmetrical winding of stator creates sinusoidal rotating magnetic field in the air gap and the induced magnetic field in the rotor has a tendency to cause the rotor to align with the stator field at a minimum reluctance position and hence the reluctance torque is developed.

1.6. OPERATING PRINCIPLE OF SYNCHRONOUS RELUCTANCE MOTOR

To understand the working principle of synchronous reluctance motor, let us keep in mind the following basic fact when a piece of magnetic material, tending to bring it into the most dense portion of the field. The force tends to align the specimen of material in such a way that the reluctance of the magnetic path lies through the material will be minimum.

In a nutshell, when a piece of magnetic material is free to move in a magnetic field, it will align itself with the field to minimize the reluctance of the magnetic circuit.

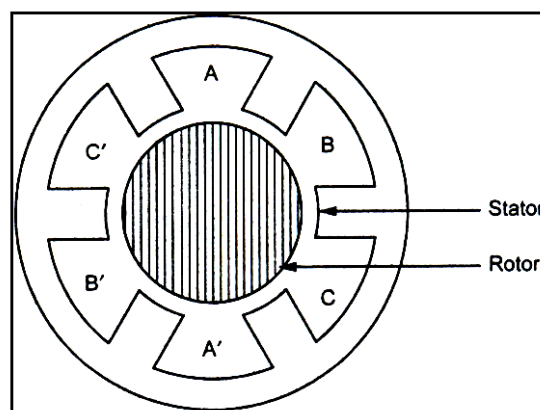

Figure. 1.20. Synchronous reluctance motor

A A' → Phase A

BB' → Phase B

CC' → Phase C

The Fig.1.20 shows the synchronous reluctance motor. The stator has open slot and semiclosed slot structures. The rotor has two types of air gap viz., radial and axial. Here for simplicity, the synchronous reluctance motor having the open slot stator and axial air gap rotor structure is shown in Fig.1.20. All the configurations of synchronous reluctance motor are having the same working principle. The stator has a 3Φ, symmetrical winding, which creates a sinusoidal rotating field in the air gap when excited. The rotor has an unexcited ferromagnetic material with polar projections. When the supply is given to the stator winding, the revolving magnetic field exerts reluctance torque on the unsymmetrical rotor tending to align the salient pole axis of the rotor with the axis of the revolving magnetic field. [It is the position, where the reluctance of the magnetic path would be minimum]. So the reluctance torque is developed by the tendency of ferromagnetic rotor to align itself with the magnetic field. The reluctance torque developed in this type of motor can be expressed as,

$$T_e = 3\left(\frac{P}{2}\right) \left[\frac{\Psi_s^2 (L_{ds} - L_{qs})}{L_{ds}} \sin \delta + \frac{\Psi_s^2 (L_{ds} - L_{qs})}{2(L_{ds}L_{qs})} \sin 2\delta \right]$$

where,

P → Number of poles

Ψ_s → Stator flux linkage

L_{ds} → Direct axis inductance with respect to synchronously rotating frame

L_{qs} → Quadrature axis inductance with respect to synchronously rotating frame

δ → Torque angle

If the reluctance torque is sufficient to start the motor and its load, the rotor will pull into step with the revolving field and continue to run at the speed of the revolving field. The motor starts as an induction motor and after it has reached its maximum speed as an induction motor, the reluctance torque pulls its rotor into step with the revolving field, so that the motor now runs as synchronous motor by virtue of its saliency.

Even though the rotor revolves synchronously, its poles lag behind the stator pole by a certain angle known as torque angle, [something similar to that in a synchronous motor]. The reluctance torque increases with the increase in torque' angle, attaining maximum value when $\delta = 45^\circ$. Reluctance motors are subjected to "cogging" since the locked rotor torque varies with the rotor position, but the effect may be minimised by skewing the rotor bars and by not having the number of rotor slots exactly equal to an exact multiple of the number of poles.

The operation of motor at synchronism with ideally zero rotor electrical losses will improve the efficiency. But the reluctance motors have approximately one third the hp rating, when compared with the condition that they would have operated as induction motors with cylindrical rotors. Although the ratio may be increased to one half by proper design of the field windings, power factor and efficiency are poorer than for the equivalent induction motor.

Once the rotor of synchronous reluctance motor is synchronized, the cage winding rotates synchronously with the stator field. Thus, the rotor winding plays no part in the steady state synchronous operation of the motor. The machine continues to operate synchronously, provided the pull-out torque of the motor is not exceeded. This is the load torque required to pull the rotor out of synchronism.

The pull in torque is defined as the maximum load torque which the rotor can pull into synchronism with a specified load inertia. The pull-in torque can be increased at the expense of larger starting current, but it is always less than the pull-out torque. The reluctance motors have been widely used in adjustable-speed multimotor drives requiring exact speed coordination between individual motors. If all the motors in multi motor drive system are accelerated simultaneously from standstill by increasing the supply frequency, the machines operate synchronously at all times, and they can be designed for optimum synchronous performance without regard to the pull-in torque requirements.

The reluctance motor unfortunately exhibits a tendency towards instability at lower supply frequencies, but it forms a low cost, robust and reliable synchronous machine. The constant speed characteristics of the synchronous reluctance motor makes it very suitable for the applications, such as, recording instruments, many kinds of timers, signalling devices and phonographs.

An expression for open circuit emf of a synchronous reluctance motor

- * The stator and rotor steel is assumed to be infinitely permeable, except in the link section .
- * This permits surfaces to be represented by equipotential.
- * q-axis also have equipotential.
- * Model has 2 boundary potentials u_0 and u_1
- * Potential \rightarrow magnetic potential, unit is amperes.
- * Link section assumed to saturate at B_s .
- * On open-circuit, flux through them is leakage flux.
- * The equipotential is assumed to be distorted by this leakage flux.
- * We can arbitrarily assign one of the 2 potential to be 0.

$$u_0 = 0$$

- * If the air gap is small, and if fringing is neglected, the radial flux density in the gap is,

$$\begin{aligned} B_g &= \frac{\mu_0}{g'} (u_1 - u_0) \\ &= \frac{\mu_0}{g'} (u_1 T) \end{aligned}$$

- * It gives rise to a rectangular distribution of flux across the pole .
- * In terms of the reluctance of the air gap,

$$\Phi_g = u_1 P_g$$

- * Where the air gap permeance is given by

$$P_g = \frac{1}{R_g} = \frac{\mu_0 A_g}{g'}$$

- * If the pole arc/pole pitch ratio is α , the stator base radius is r_1 - stack length is l .

$$A_g = \alpha \frac{\pi}{P} r_1 l$$

- * On the underside of pole-piece, magnet can be represented as a magnetic equivalent circuit.

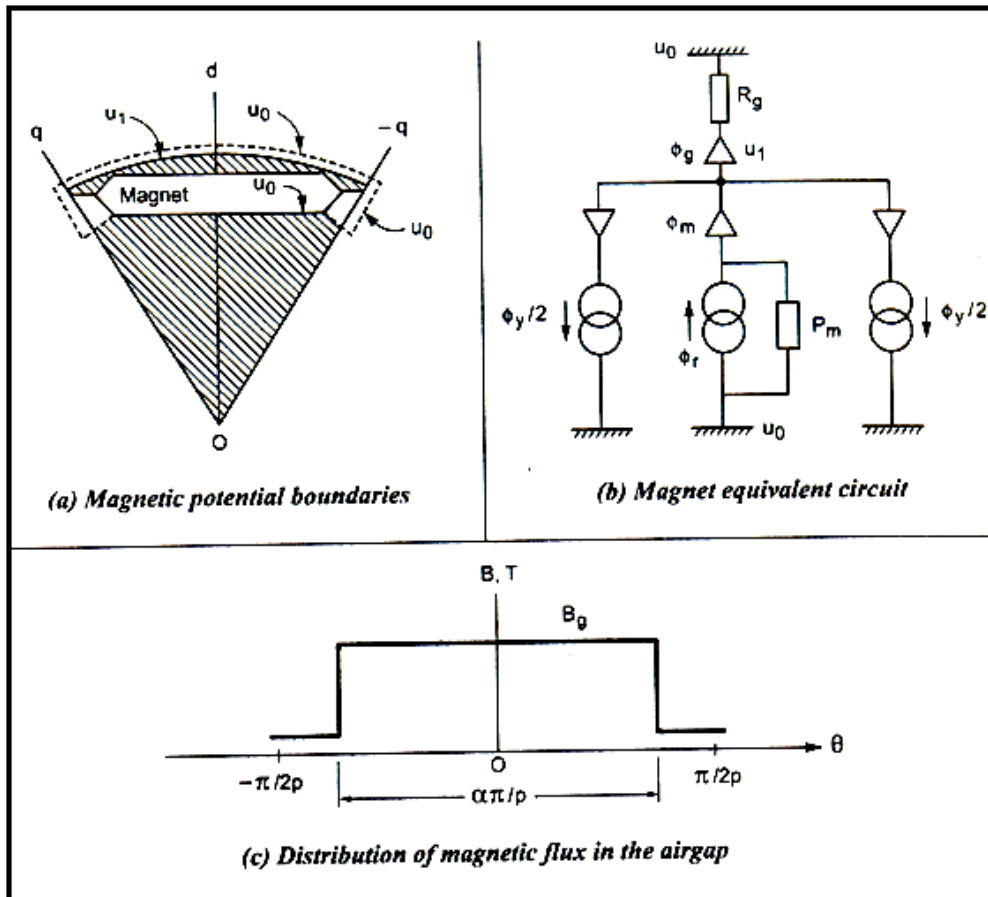

- * Link sections included in the equivalent circuit.

- * Each carrying fixed leakage flux,

$$\frac{1}{2} \phi_y = B_s y l$$

- * Magnetic potential difference across the magnet is same as that across the air gap

$$u_1 = \frac{\Phi_r - \phi_y}{P_m + P_g}$$

$\Phi_r \rightarrow$ Magnet remanent flux

$\Phi_r \rightarrow B_r A_m$

$A_m \rightarrow$ Pole area of the magnet

- * The effective permeance P_m assigned to the magnet includes a component.

- * This leakage flux flows in a circumferential direction .

- * Magnet pole width were increased

$$W'_m = a v (W_m' W_m + h) = W_m + h/2$$

$$A'_m = W'_m l$$

$$P_m = \frac{\mu_{rec} \mu_o A'_m}{l_m}$$

* Hence the air gap flux is given as

$$\phi_g = u_1 P_g = \frac{\phi_r - \phi_y}{1 + P_m + R_g} = B_g A_g$$

- * The pole piece can be regarded as a "potential island".
- * The model is "per-pole" model and is same for every pole in the machine.
- * The rectangular flux distribution in the air gap is identical to the ideal distribution calculated for surface magnet motor.
- * Motor could be driven as a square-wave motor.
- * This would be true if there were no reluctance torque.
- * For reluctance torque to be 0, X_d and X_q must be equal.
- * The fundamental open circuit flux per pole can be determined by Fourier analysis of the waveform.

$$\phi_{M1} = \frac{B_{M1} D l}{P}$$

* Amplitude of the fundamental component of the air gap flux due to magnet acting alone is,

$$B_{M1} = k_1 B_g \quad \text{Where } k_1 = \frac{4}{\pi} \sin \frac{\alpha \pi}{2}$$

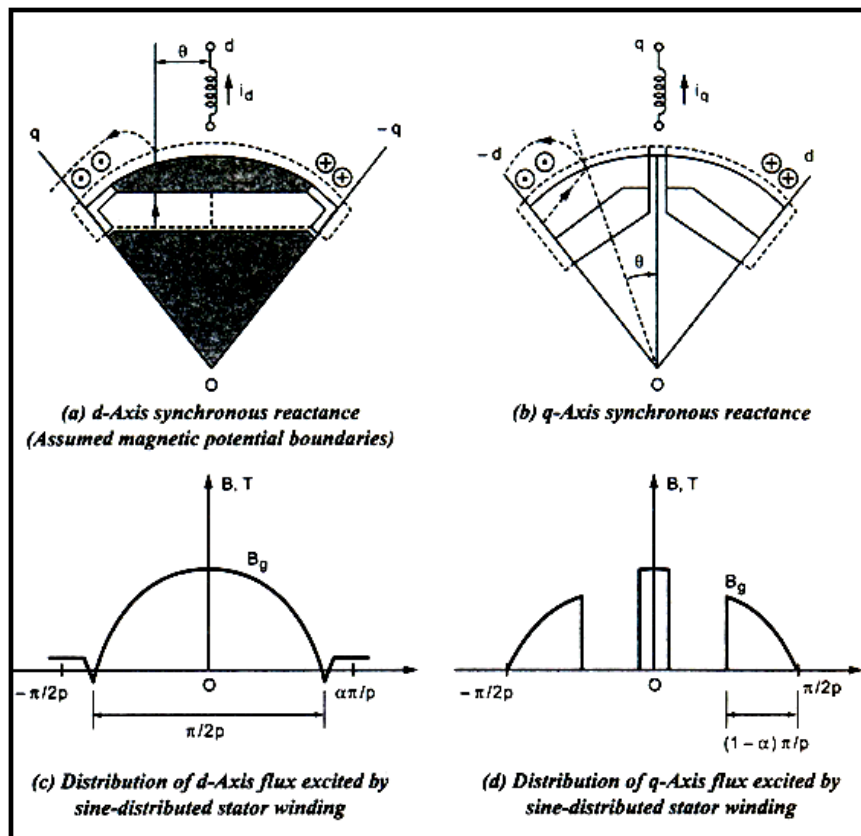

- * With rectangular distribution of the flux, the result is

$$\phi_{M1} = \phi_g \frac{8}{\pi^2 \alpha} \sin \frac{\alpha \pi}{2}$$

- * For a practical winding with N_{ph} series turns per phase and a winding factor K_{w1}

$$E_{q1} = \frac{2\pi}{\sqrt{2}} (K_{w1} N_{ph}) \phi_{M1} f$$

- * The result is

- * This equation can also be expressed in the form

$$\tilde{E}_{ph} = jE_{q1} = j\omega \tilde{\psi}_{M1} = \frac{1}{\sqrt{2}} K_{w1} N_{ph} \phi_{M1}$$

1.7. ADVANTAGES OF SYNCHRONOUS RELUCTANCE MOTOR

1. There is no need for field excitation in this motor at zero torque thus the electromagnetic spinning losses are eliminated.
2. There is no concern with demagnetization, hence synchronous reluctance machines are inherently more reliable than permanent magnet machines.
3. The rotors of synchronous reluctance machine can be constructed entirely from high strength, low cost materials.
4. The torque ripple in this motor is low.
5. The motor can be operated from standard P.W.M. ac inverters.
6. The synchronous reluctance motor has the capability to survive very high temperature.
7. The motor has simple and rugged construction.
8. It has high speed capability.
9. With the high saliency ratio (L_d/L_q), a power factor of 0.8 can be reached. Also, since there is no copper loss, efficiency of reluctance motor is higher than an induction motor.
10. Because of its inherent simplicity, it can be applied in multimotor drive where a number of motors operate synchronously with common power

1.8. DISADVANTAGES OF SYNCHRONOUS RELUCTANCE MOTOR

1. When compared with induction motor, the synchronous reluctance motor is slightly heavier and has low power factor. But by increasing the saliency ratio L_{ds} / L_{qs} the power factor can be improved.
2. The cost is higher than induction motor.

1.9. APPLICATIONS OF SYNCHRONOUS RELUCTANCE MOTOR

1. It is popularly used in many low power applications such as fiber spinning mills because of inherent simplicity, robustness of construction and low cost.
2. Widely used for many constant speed applications such as recording instruments, timing devices, control apparatus and phonograph.
3. Used as proportioning devices in pumps or conveyors.
4. Applied in auxiliary time mechanism,

5. Used in processing of continuous sheet or film material.
6. Used in regulators and turntables.
7. Applied in wrapping and folding machines.
8. It can be used in synchronized conveyors.
9. In metering pumps also, the synchronous reluctance motor is used.
10. Used in synthetic fibre manufacturing equipment.

1.10. PHASOR DIAGRAM (OR) TORQUE EQUATION

The idealized structure of a reluctance motor is same as that of the salient pole synchronous machine except that the rotor does not have any field winding. The rotor of the modern reluctance machine designed with iron laminations in the axial direction separated by non-magnetic material.

Generally in salient-pole motors, air-gap is much greater between the poles than along the poles. (*i.e.*,) air gap is non-uniform. So the analysis is not easier when compared with cylindrical rotor synchronous motors which have uniform air-gap. Also the characteristics of a salient pole machine differs from those of a non salient pole machine because of non uniform airgap reluctance in the d^e and q^e axes. The resulting asymmetry in the direct and quadrature axes magnetizing reactances causes the corresponding synchronous reluctances to be unsymmetrical.

The Figures 1.21(a) and 1.21(b) show the phasor diagram of synchronous reluctance motor. Since the machine is considered as a balanced 3 phase circuit, it is sufficient to draw the phasor diagram for only one phase. In general, for a two phase machine [of Fig.1.6(b)], we need to represent both $d^s - q^s$ (stator) and $d^r - q^r$ (rotor) circuits and their variables in a synchronously rotating $d^e - q^e$ frame.

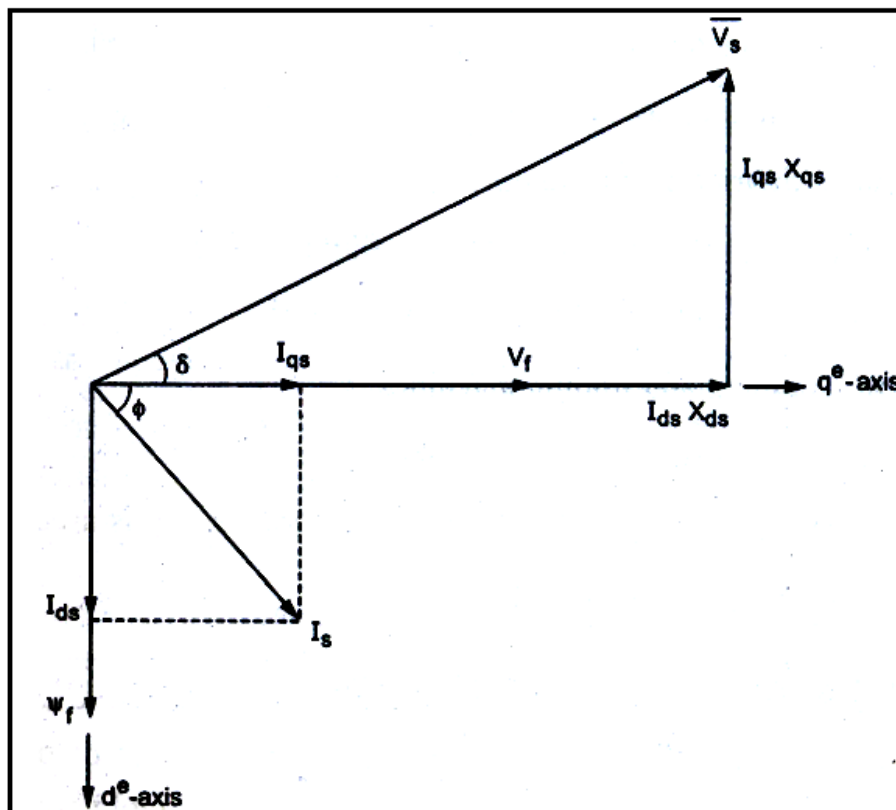

Figure.1.21. (a) Phasor diagram of synchronous reluctance motor with q axis as reference. A special advantages of the $de - qe$ dynamic model of the machine is that all the sinusoidal variables in stationary frame appear as d.c. quantities in synchronous frame.

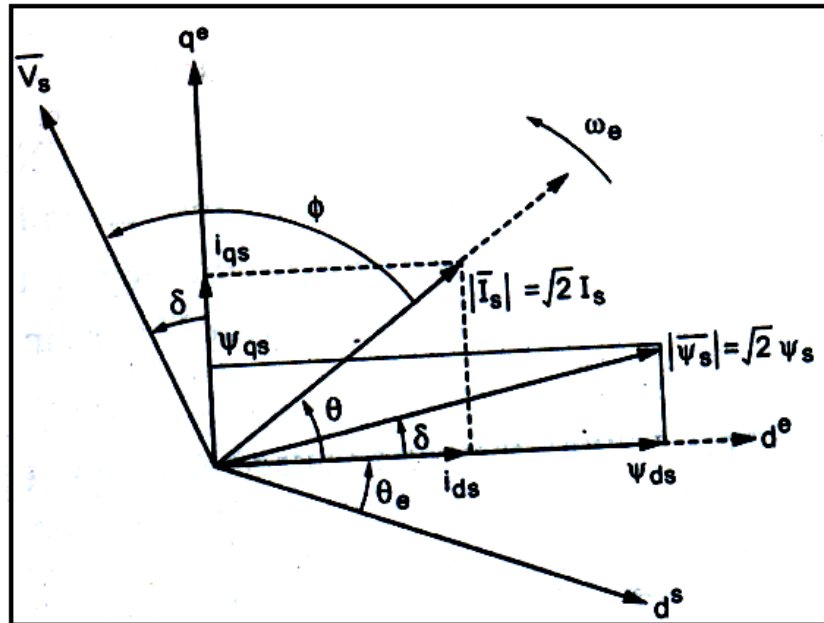

Figure. 1.21. (b) Phasor diagram of synchronous reluctance motor with d axis as reference [shown with vectors]

The motor has d -axis reactance X_d and q -axis reactance X_q . Also, I_d and I_q are the direct and quadrature axis currents respectively. The following symbols should be clearly kept in mind while studying the phasor diagram.

Ψ_{qs} - Quadrature axis flux linkage with respect to synchronously rotating frame

Ψ_{ds} - Direct axis flux linkage with respect to synchronously rotating frame

X_{ds} - Direct axis synchronous reactance

X_{qs} - Quadrature axis synchronous reactance

I_{ds} - de component of the stator current

I_{qs} - qe component of the stator current

I_s - Stator current

V_s - Phase voltage

V_f - The excitation or speed emf [eventhough it is accounted for our convenience in the phasor diagram 1.21(a), it will be made zero during the derivation as there is no excitation in synchronous, reluctance motor Hence, it is absent in the phasor diagram 1.21(b)].

Ψ_s - Space vector flux

Ψ_s - Stator flux linkages

θ - Stator power factor angle

δ - Torque angle [In general, it is the angle between V_s and V_f in synchronous machine.

At higher value of I_{ds} , the corresponding flux [say Ψ_{ds}] tends to saturate. In fact there is some cross saturation effect of L_{ds} due to I_{qs} current. The stator resistance drop has been

neglected for simplicity. Note that there is no excitation in synchronous reluctance motor, hence the (excitation flux) Ψ_f phasor and corresponding (excitation or speed *emf*) V_f phasor are absent in the phasor diagram 1.21(b). Since, the stator supplies magnetizing current like an induction motor, the stator power factor angle Φ is large. From the phasor diagram 1.21(a), the basic voltage equation neglecting the effect of resistance is given by,

$$\bar{V}_f = \bar{V}_s + j\bar{I}_{ds}X_{ds} + j\bar{I}_{qs}X_{qs}$$

$$\bar{I} = \bar{I}_{ds} + \bar{I}_{qs}$$

It is evident from the phasor diagram 1.21(a) that I_q is in phase with V_f and I_{ds} is in phase quadrature with V_f .

$$V_s = V_f - j I_{ds} X_{ds} - j I_{qs} X_{qs}$$

$$V_s \cos \delta = V_f - I_{ds} X_{ds}$$

$$I_{ds} = \frac{V_s \cos \delta - V_f}{X_{ds}} \quad \text{and} \quad I_{qs} X_{qs} = V_s \sin \delta$$

$$I_{qs} = \frac{V_s \sin \delta}{X_{qs}}$$

Also we can write $I_s \cos \Phi = I_{qs} \cos \delta - I_{ds} \sin \delta$.

In the phasor diagram (1.21)(a) the excitation or speed *emf* V_f is shown aligned with q^e axis, where as Ψ_f is aligned with the d^e axis. The phase voltage V_s and phase current I_s are resolved into corresponding d^e and q^e components, and a voltage phasor diagram is drawn with corresponding reactive drops.

$$I_s \cos \phi = \frac{V_s \sin \delta}{X_{qs}} \cos \delta - \frac{V_s \cos \delta - V_f}{X_{ds}} \sin \delta$$

$$= \frac{V_s}{X_{qs}} \sin \delta \cos \delta - \frac{V_s \sin \delta \cos \delta - V_f \sin \delta}{X_{ds}}$$

$$= \frac{V_s}{X_{qs}} \sin \delta \cos \delta - \frac{V_s}{X_{ds}} \sin \delta \cos \delta + \frac{V_f \sin \delta}{X_{ds}}$$

$$= \frac{V_f \sin \delta}{X_{ds}} + V_s \sin \delta \cos \delta \left(\frac{1}{X_{qs}} - \frac{1}{X_{ds}} \right)$$

$$= \frac{V_f}{X_{ds}} \sin \delta + V_s \left(\frac{X_{ds} - X_{qs}}{X_{qs} X_{ds}} \right) \sin \delta \cos \delta$$

$$I_s \cos \phi = \frac{V_f}{X_{ds}} \sin \delta + V_s \left(\frac{X_{ds} - X_{qs}}{2 X_{qs} X_{ds}} \right) \sin 2\delta$$

The Power Input to the motor is $P_{in} = 3 V_s I_s \cos \Phi$

Substituting the value of $I_s \cos \Phi$

$$P_{in} = 3V_s \left[\frac{V_f}{X_{ds}} \sin \delta + V_s \left(\frac{X_{ds} - X_{qs}}{2 X_{qs} X_{ds}} \right) \sin 2\delta \right]$$

$$P_{in} = \left[\frac{3V_s V_f}{X_{ds}} \sin \delta + \frac{3V_s^2 (X_{ds} - X_{qs})}{2 X_{qs} X_{ds}} \sin 2\delta \right]$$

Since , there is no exciting filed winding in synchronous reluctance motor, in the equation, the value of $V_r = 0$.

$$P_{in} = \left[\frac{3V_s^2(X_{ds} - X_{qs})}{2 X_{qs}X_{ds}} \sin 2\delta \right]$$

$$P_{in} = V_s^2 \left[\frac{3(X_{ds} - X_{qs})}{2 X_{qs}X_{ds}} \sin 2\delta \right]$$

$$V_s^2 = \left[\frac{P_{in} 2(X_{ds}X_{qs})}{3 (X_{ds}-X_{qs})} \right]$$

$$V_s = \sqrt{\frac{2P_{in}(X_{ds}X_{qs})}{3 (X_{ds}-X_{qs})}} \text{ is voltage equation}$$

If the machine losses are ignored

$$P_{in} = P_m$$

Where

P_{in} = Input power to the motor

P_m = Power delivered to the shaft of the motor

Let as assume $P_{in} = P_m = P$

In general $P = \omega_e T_e$. But when we consider the load angle in electrical Degree.

$P_{in} = (2/P) \omega_e T_e$ Where P = Number of Poles.

$P_{in} = (2/P) \omega_e T_e$

$T_e = (P/2)(1/\omega_e)(P_{in})$

$$T_e = (P/2)(1/\omega_e) \left[\frac{3V_s^2(X_{ds} - X_{qs})}{2 X_{qs}X_{ds}} \sin 2\delta \right]$$

$$T_e = (P/2)(3/\omega_e) \left[\frac{V_s^2(X_{ds} - X_{qs})}{2 X_{qs}X_{ds}} \sin 2\delta \right]$$

$$\psi_s = \left| \frac{V_s}{\omega_e} \right| \angle \frac{-\pi}{2}$$

$$\psi_s \omega_e = |V_s|$$

The stator flux linkage , $X_{ds} = \omega_e L_{ds}$

$$X_{qs} = \omega_e L_{qs}$$

$$T_e = (P/2)(3/\omega_e) \psi_s^2 \omega_e^2 \left[\frac{\omega_e L_{ds} - \omega_e L_{qs}}{2 \omega_e^2 L_{ds} L_{qs}} \sin 2\delta \right]$$

$$T_e = (P/2)(3/\omega_e)\psi_s^2 \omega_e^2 \left[\frac{\omega_e(L_{ds} - L_{qs})}{2\omega_e^2 L_{ds}L_{qs}} \sin 2\delta \right]$$

$$T_e = 3(P/2)\psi_s^2 \left[\frac{(L_{ds} - L_{qs}) \sin 2\delta}{2L_{ds}L_{qs}} \right]$$

$$T_e = 3(P/2)(\hat{\psi}_s^2/2) \left[\frac{(L_{ds} - L_{qs}) \sin 2\delta}{2L_{ds}L_{qs}} \right]$$

Where space vector flux magnitude $\psi_s^2 = \sqrt{2}\psi_s$,

P = No. of poles , δ = Torque

Substituting $\sin 2\delta = 2\sin\delta \cos\delta$

$$T_e = (3/2)(P/2)(\hat{\psi}_s^2/2) \left[\frac{(L_{ds} - L_{qs})}{2L_{ds}L_{qs}} 2\sin\delta \cos\delta \right]$$

$$= (3/2)(P/2)(\hat{\psi}_s^2/2) \left[\frac{(L_{ds} - L_{qs}) \sin\delta \cos\delta}{L_{ds}L_{qs}} \right]$$

$$\text{put } \sin\delta = \frac{\psi_{qs}}{\hat{\psi}_s} \text{ and } \cos\delta = \frac{\psi_{ds}}{\hat{\psi}_s}$$

$$T_e = (3/2)(P/2) \left[\frac{(L_{ds} - L_{qs})}{L_{ds}L_{qs}} \psi_{qs}\psi_{ds} \right]$$

$$\psi_{ds} = L_{ds}i_{ds}$$

$$\psi_{qs} = L_{qs}i_{qs}$$

$$T_e = (3/2)(P/2) [(L_{ds} - L_{qs})i_{qs} i_{ds}]$$

$$L_{ds} = \psi_{ds} / i_{ds}$$

$$L_{qs} = \psi_{qs} / i_{qs}$$

$$T_e = (3/2)(P/2) [\psi_{ds}i_{qs} - \psi_{qs}i_{ds}]$$

which is the general torque equation

1.11. CHARACTERISITC OF SYNCHRONOUS RELUCTANCE MOTOR

1.11.1. Torque angle characteristic

We know that the developed electrical torque of synchronous reluctance motor canbe expressed as,

$$T_e = 3(P/2)\psi_s^2 \left[\frac{(L_{ds} - L_{qs}) \sin 2\delta}{2L_{ds}L_{qs}} \right]$$

The plotting of the above equation for different field excitations gives the various torque (T_e) - δ angle curves as shown in Fig.1.22, for both motoring and generating modes. The steady-

state limit corresponds to the maximum points and is indicated by the dots in the Fig.1.22. It is evident from the equation that if V_s/ω_e is maintained constant (*i.e.*, the supply voltage is changed in proportion to the frequency), for a fixed excitation and torque angle, the developed torque remains constant. But we have defined the synchronous reluctance motor as the motor which has the same structure as that of a salient pole synchronous motor except that it does not have a field winding on the rotor. So, there is no excitation in the motor. So, in the torque angle characteristic of fig1.22 drawn for salient pole machine, the reluctance torque component is the lowest curve which corresponds to zero percent excitation or zero excitation, where the stability limit is reached at $\delta = \pm \pi/4$.

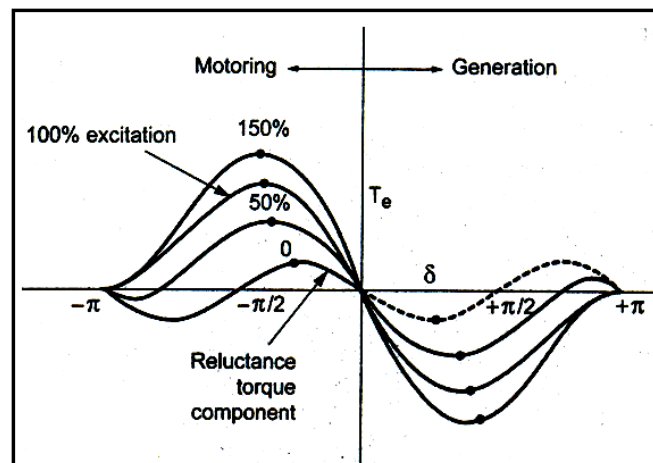

Figure. 1.22. Torque-S angle characteristics of salient pole machine

The reluctance torque component is in such a shape as shown in Fig.1.22 because the ideal synchronous reluctance machine, is having a rotor whose structure is such that the inductance of the stator windings in the dq reference frame varies sinusoidally from a maximum value L_d [Direct inductance] to a minimum value L_q [Quadrature inductance] as a function of angular displacement of the rotor.

1.11.2. Torque - speed characteristic

In synchronous reluctance motor, the reluctance torque is developed by the tendency of a ferromagnetic material to align itself with a magnetic field. On a fixed frequency a.c. supply, the synchronous reluctance motor is not self-starting unless the rotor is fitted with a squirrel-cage winding to permit starting by induction motor action. When the rotor speed approaches synchronous speed, the reluctance torque is super imposed on the induction motor torque, and as a result, the rotor speed oscillates above and below its average value. If the load torque and inertia are not excessive, instantaneous rotor speed increases such as to reach synchronous speed and the rotor locks into synchronism with the stator field. The Fig.1.23 shows the torque-speed characteristics of synchronous reluctance motor.

The motor starts as an induction motor at anywhere from 300 to 400 percent of its full load torque (depending upon the salient pole axis of the rotor with the axis of the revolving magnetic field) as a two phase motor. When the motor reaches its maximum speed as an induction motor, the reluctance torque pulls its rotor into step with the revolving field, so that the motor now runs as synchronous motor by virtue of its saliency. As it approaches synchronous speed, the reluctance torque is sufficient to pull the rotor into synchronism with

the pulsating single phase field. From the Fig.1.23, it is known that even though the torque is increased, the motor speed remains constant. But when the torque exceeds maximum value, the motor goes out of synchronism.

The motor operates at constant speed upto a little over 200% of its full load torque.

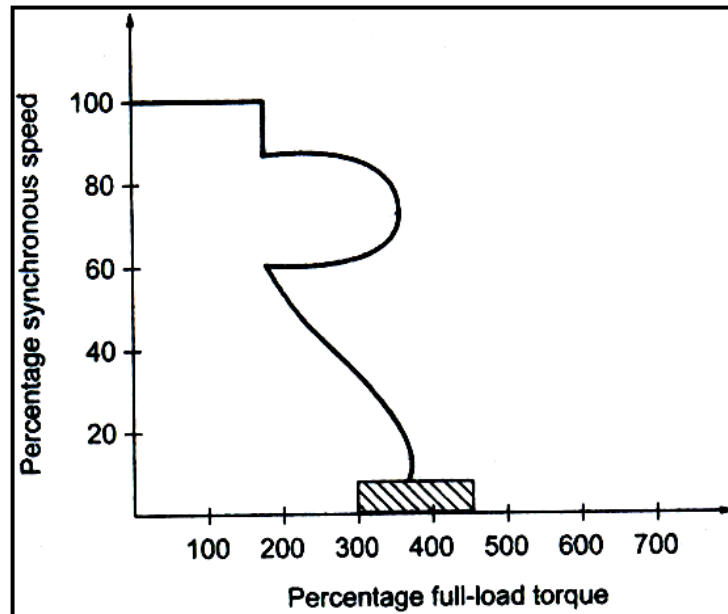

Figure. 1.23. Torque-speed characteristics of synchronous reluctance motor

If it is loaded beyond the value of pull out torque, it will continue to operate as a single phase induction motor up to 500% of its rated output.

The torque-speed characteristics of synchronous reluctance motor is shown in fig.

- The motor starts at anywhere from 300 to 400 percent of its full load torque as a two phase motor.
- As a result of the magnetic rotating field created by a starting and running winding displaced 90 degree in both space and time.
- At 3/4th of the synchronous speed a centrifugal switch opens with starting winding and the motor continues to develop a single phase torque product by its running winding only.
- As its approaches synchronous speed the reluctance torque is sufficient to pull rotor into synchronism with pulsating single phase field .
- The motor operates at constant speed up to a little over 200% of its full load torque.
- If it is loaded beyond the value of pull out torque it will continue to operate as a single phase induction motor upto 500% of its rated output.

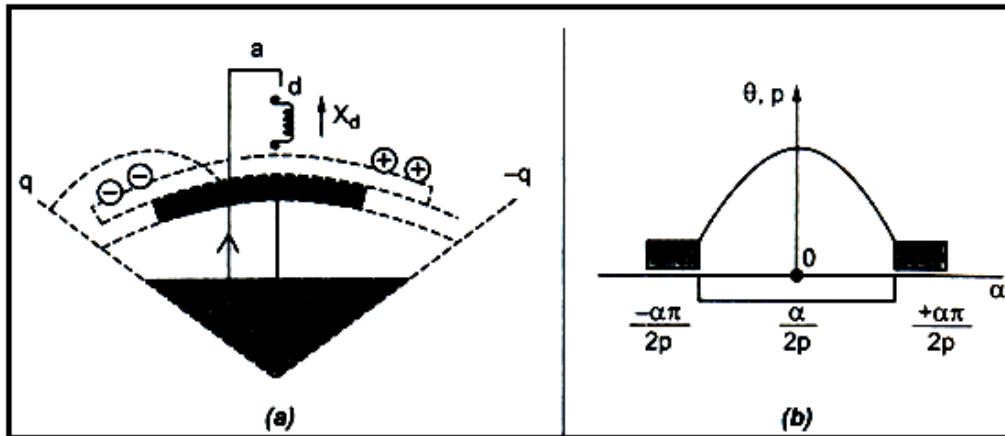

Figure. 1.24. Circle diagram of synchronous reluctance motor

- In the complex phasor diagram the maximum continuous phase current define circular locus Fig.1.24(a) and (b).
- With a sine-distribution of ampere conductors whose magnetic axis is aligned with the d-axis.
- The mmf integral $\int Hdl$ for flux lines that cross the air gap via the pole is given.
- Fig. (a) calculate of d-axis synchronous reactance showing the assumed magnetic potential boundaries. Fig.(b) Distribution of d-axis flux excited by sine-distributed stator winding.
- The expression equals one half the ampere-conductors enclosed within a closed flux line that crosses the air gap at the angle θ . The other half of the enclosed ampere conductors can be thought of as forcing the flux line across the air gap via the adjacent poles. Thus the equations developed here are all on a 'per-pole' basis.
- If all the poles are in series, N , is the number of the turns in series per phase, and N_s/p is the number of turns per pole. Flux entering the sides of the pole is classified as fringing flux and is ignored at this stage.
- The dotted line drawn across the rotor and along the q-axis is in equipotential V_0 and as before, this potential may be assigned to zero with no loss generality, since it is common between adjacent poles.

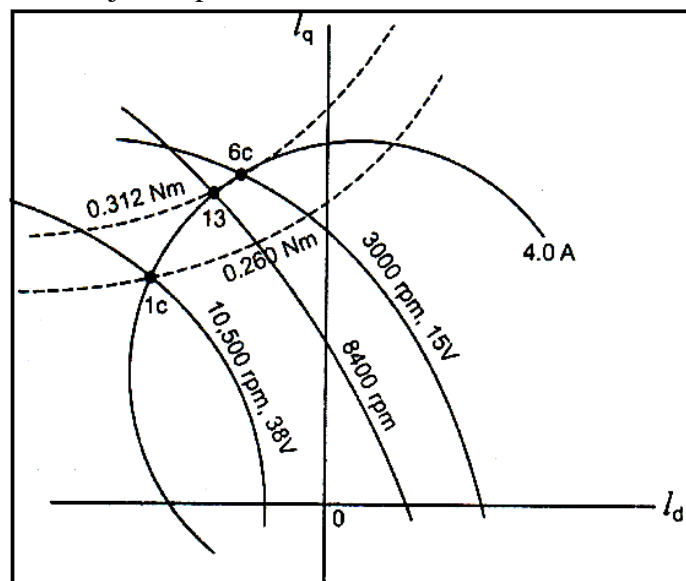

Figure.1.25

- The Pole Pieces is at a uniform magnetic potential V_1 as yet unknown, the Fig.1.25 circle diagram showing loci of maximum current limited by both current and voltage ,for hybrid motor with ceramic magnets ($0.4T$; $V_1 = 15V$ and $38V$).
- This is a rectangular hyperbola asymptotic to the negative d-axis and to a q-axis offset to the right.
- Note that all these relationship are independent of frequency and speed.
- With high energy magnet the offset E_q/A_x is so large that the constant-torque contours are almost horizontal straight lines, as they arc for the surface magnet. This is again shows the similarity between the two machines when high energy magnets are used.
- For the pure synchronous reluctance motor the constant-torque contours are also rectangular hyperbolas but with no offset.
- When the hybrid motor is under excited , as it may well be with ceramic magnets, the constant torque contours have more curvature.
- The torque contour for 0.312 Nm in Fig.1.25 is tangent to the maximum current circle at point. This torque is attainable at 300 rpm with a controller voltage of only 15 V.
- As the speed increases the size of the voltage - limited current locus can be maintained by increasing the voltage (by P.W.M control) up to maximum of $38V$, which is reached at 8400 rpm (point 13). This is the highest speed at which the torque of 0.312 Nm can be attained, giving an electromagnetic power of 274.5 W at the air gap.
- If the speed is raised to 10500 rpm, the torque must decrease as the operating point is constrained by maximum current limit.

1.12. VERNIER MOTOR (or) TYPES OF SYSREL MORTOR.

A vernier motor is an unexcited reluctance type synchronous motor which has the feature of high torque at low speed. This high torque at low speed feature is based on the 'magnetic gearing effect' and applied where mechanical gearing is undesirable. Since the vernier motor is a synchronous machine, useful torque is developed only when it operates at synchronous speed. To be capable of self-starting without any auxiliary means, the rotor must be pulled into synchronism within the time of one half cycle. Hence, the vernier motor must be designed to run at a low speed [around 200 rpm] and to have high torque to inertia ratio.

1.12.1. Construction

The vernier motor has a stator and rotor.

Stator

The stator of the vernier motor has uniformly pitched teeth units surface towards the air gap. In between the teeth, the stator has slots and a distributed winding. There are two typical configurations that exist for stator of vernier motor.

- (i) Split - pole type
- (ii) Open - slot type.

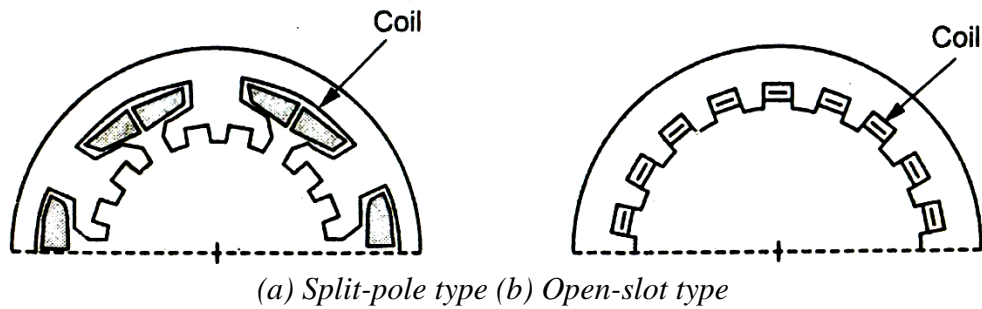

Figure. 1.26. Two types of the stator configurations of vernier motor

The split-pole type configuration finds its application in most of the small power stepper motors, in which the large-number of teeth is necessary for the high-resolution Position control. But this structure has problems in case of a large machine in the sense that the slots between the teeth become large 'dead' spaces, and that the copper density in a slot must be lower because of the difficulty in winding coils due to the narrow open slot. In open-slot type configuration, there is no such "dead" spaces because its slots are reutilized as the locations for the coils and the coils can apparently be wound more densely. Therefore, for high power applications, open-slot type is more suitable.

Rotor

The rotor of vernier motor is a slotted iron core without winding. It has three typical configurations.

- (i) Axially sandwiched magnet type
- (ii) Surface magnet type
- (iii) Inset surface magnet type.

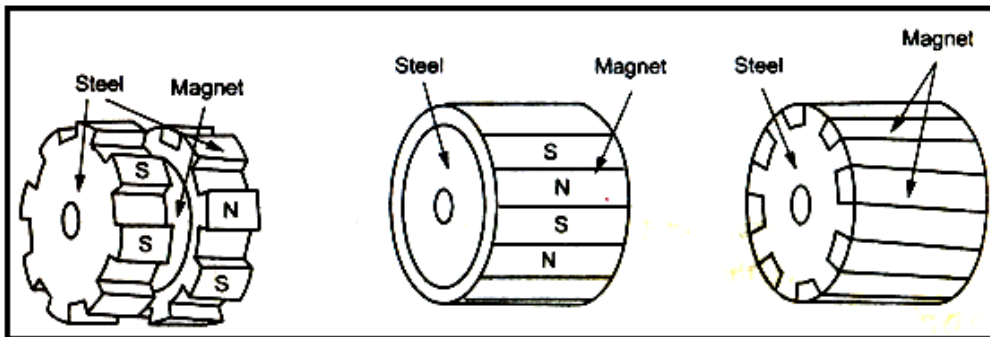

Figure. 1.27. Three types of the rotor structures

In the axially sandwiched magnet type, the iron part of the rotor is directly facing the air gap. So, the coil inductance tends to be quite large and can reach 2 or 3 p.u. The another reason for the tendency of coil to have high inductance is the number of poles should be small for obtaining a high torque. The same is the case for inset surface magnet type rotor configuration. But from the point of view of the power factor and current control this value of 2 or 3 n.u coil inductance is too him. In surface magnet type of rotor configuration, because of the presence of virtual air gap, the value of inductance is in reasonable limit.

1.12.2. Principle of operation of Vernier Motor

To understand the principle of operation of a vernier motor, consider the following Fig.1.28 which shows a 2 pole machine with 12 stator slots and 10 rotor slots.

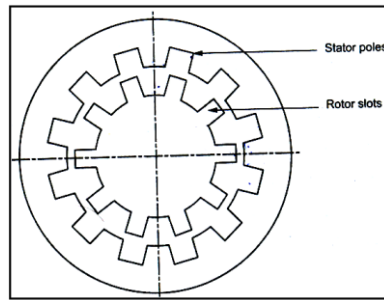

Figure. 1.27. Vernier motor

The stator and rotor teeth are facing each other in the vertical axis at the position shown in above figure. The fluxes in the air gap are assumed to be in the radial direction. The axes at which maximum and minimum permeance occur are the direct and quadrature axes respectively of the vernier motor. The permeance of air space between stator and rotor at any location is inversely proportional to the radial length of air space at that location. In the Fig.1.27, The stator teeth are facing the rotor slots in the horizontal axis. So, at this position, the maximum permeance is along the vertical axis and the minimum permeance is along the horizontal axis.

When the stator winding is excited by poly phase supply, a rotating magnetic field is produced. This rotating magnetic field is introduced in the air gap of the machine, the rotor now rotates slowly and at a definite fraction of the speed of the rotating field. As the rotor speed steps down from the speed of the rotating field, the motor torque steps up. This high torque at low speed feature is based on the so-called “magnetic gearing effect”. Whenever the rotating field rotates for 90 degrees, the rotor will rotate one half its slot pitch. When the rotor is rotated one half of its slot pitch, the rotor slots will face the stator teeth in the vertical axis. The rotor and stator teeth will face each of other in the horizontal axis. The axis of maximum permeance is now horizontal and the axis of minimum permeance is now vertical. Thus the rotor movement of one half rotor slot pitch results in a 90 degree displacement of the permeance axes.

The peculiar feature of vernier motor is such that a small displacement of the rotor produces a large displacement of the axes of maximum and minimum permeance. When the rotor rotates, the permeance wave rotates at much faster speed approximately five times the rotor speed).The permeance distribution curve is shown in Fig.1.28 (a). The technique of replacing a permeance curve of Fig. 1.28(b) by an equivalent curve of Fig.1.26 (a) is an accepted practice in machine design.

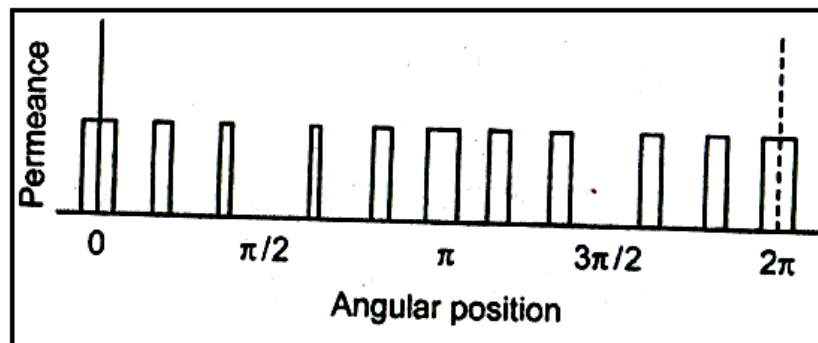

Figure.1.28 (a) Air gap permeance distribution of vernier motor

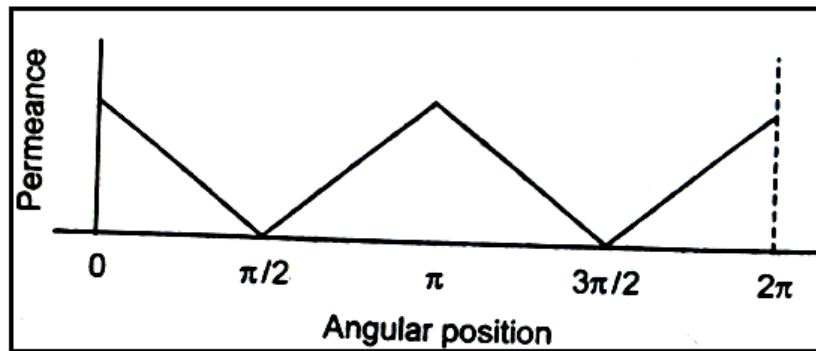

Figure.1.28 (b) Equivalent permeance

From the analysis of air gap permeance distribution in a vernier motor, it is realized that the design of a vernier motor is equivalent to the design of an ordinary poly phase reluctance motor with an odd shaped rotor so that the air gap permeance distribution is a displaced triangular wave as shown in Fig.1.28(b).

1.13. SYNCHRONOUS RELUCTANCE MOTORS - APPLICATIONS

Since synchronous reluctance motors are completely free of magnets they can be used in a wide variety of applications.

Shipping applications:

∴ Synchronous reluctance motors can be presented as a possible alternative for all electrical ship applications.

∴ In synchro lifts for lifting ships out of water.

Domestic applications :

∴ Synchronous reluctance motors are use in house hold appliances like washing machines, time devices, wrapping and folding machines.

Industrial applications

∴ Prominently used in AC servo applications where a variable speed motor is required. Other applications would include fiber-spinning mills, metering pumps and industrial process equipments.

TWO MARK QUESTIONS & ANSWERS

1. What is a synchronous reluctance motor?

It is the motor driven by reluctance torque which is produced due to tendency of the salient rotor poles to align themselves with synchronously rotating field produced by stator. In this motor, the magnets are left out of the rotor or they are demagnetized. The rotor of a synchronous reluctance motor has salient poles but neither have field windings nor permanent magnets.

2. What are the types of synchronous reluctance motor?

A. The main types are,

1. Cageless
2. Line-start

B. According to the magnetization (when the stator winding is energized),

1. Radial type
2. Axial type

3. State the principle of operation of synchronous reluctance motor.

When a piece of magnetic material is located in a magnetic field, a force acts on the material tending to bring it into the most dense portion of the field. The force tends to align the specimen of material in such a way that the reluctance of the magnetic path that lies through the material will be minimum. In general, reluctance torque is developed by the tendency of a ferromagnetic material to align itself with a magnetic field. (*i. e.,*) when the stator winding is energized, the evolving magnetic field produces reluctance torque.

4. State any four advantages of synchronous reluctance motors.

1. It can operate from essentially standard P.W.M. a.c. inverters.
2. Lower torque ripple.
3. Simple and rugged construction.
4. It has high speed capability.

5. List any four applications of synchronous reluctance motor.

1. The synchronous reluctance motor is widely used for many constant speed applications such as recording instruments, timings devices, control apparatus and photograph.
2. It is employed for low power application such as spinning mills.
3. Used in processing of continuous sheet or film material;
4. Applied in synthetic fibre manufacturing equipment.

6. Define: Torque Angle.

In reluctance type synchronous motor, when the load is increased lightly, the rotor momentarily slows down, causing the salient poles of the rotor to lag the rotating field. This angle of lag is called the torque angle.

7. What is vernier motor?

A vernier motor is an unexcited reluctance type synchronous motor which has the feature of high torque at low speed. This feature is based on the principle of vernier or magnetic gearing effect such that a small displacement of the rotor produces a large displacement of the axes of maximum and minimum permeance.

8. Write down the important features of vernier motor.

1. High torque to inertia ratio.
2. High torque at low speed.
3. The stator has uniformly pitched teeth on its surface towards the air gap.
4. The air gap permeance distribution is a displaced triangular wave.

9. Define reluctance torque.

In a synchronous reluctance motor, the torque which is produced at critical speed, due to the tendency of the salient rotor poles to align themselves with synchronously rotating field produced by the stator is known as reluctance torque. (*i.e.,*) the reluctance torque is produced, when the low-reluctance path provided by the salient rotor poles causes them to snap into synchronism with the rotating flux of the stator and the rotor is pulled around by simple magnetic attraction.

10. What is meant by "flux concentrating" or "flux focussing" design synchronous reluctance motors?

In a six-pole circumferentially magnetized synchronous reluctance motor, the design is such that the magnet pole area exceeds the pole area at the air-gap, producing an air gap flux-density higher than that in the magnet. This arrangement is known as "flux concentrating" or "flux focussing" design.

11. What are the factors to be considered while designing a vernier motor?

1. The airgap permeance wave should have the same number of poles as the stator *mmf* wave.
2. The number of stator (N_1) and rotor slots (N_2) should be such that $N_1 = N_2 + P$, where, P is number of poles of the rotating magnetic field.

12. What are the applications of vernier motor?

1. Direct drive applications.
2. Applications which require high torque at low speed.

13. When does a PM synchronous motor operate as a synchronous reluctance motor?

If the cage winding is included in the rotor and the magnets are left out or demagnetized, a PM synchronous motor operates as a synchronous reluctance motor

REVIEW QUESTIONS

1. Describe the constructional features of synchronous reluctance motor.
2. What are the types of synchronous reluctance motor? With neat diagrams, explain the same.
3. Explain the operation of axial type synchronous reluctance motor.
4. Explain the operation of radial type synchronous reluctance motor.
5. Explain the working principle of synchronous reluctance motor.
6. Draw the steady state phasor diagram of synchronous reluctance motor and explain.
7. Draw and discuss a typical torque-speed characteristics of synchronous reluctance motor.
8. Describe the constructional features of vernier motor.
9. Explain the working principle of vernier motor with neat diagram.
10. Enumerate the advantages, disadvantages and applications of synchronous reluctance motor.