UNIT 7 PROJECTION AND TOOLMAKER'S MICROSCOPE

Structure

- 7.1 Introduction
 - Objectives
- 7.2 Principles of Optical Projectors
 - 7.2.1 Parts of a Projector
 - 7.2.2 Magnification of a Projector
- 7.3 Types of Projector
 - 7.3.1 Horizontal Projector
 - 7.3.2 Vertical Projector
 - 7.3.3 Cabinet Projector
- 7.4 Applications of Projector
- 7.5 Advantages of Projector
- 7.6 Toolmaker's Microscope
- 7.7 Summary
- 7.8 Key Words
- 7.9 Answers to SAQs

7.1 INTRODUCTION

The adaptation of optical principles to the practical needs of workshop inspection has given rise to the construction of toolmaker's microscope and projectors. These apparatuses incorporate every feature of accuracy and refinement in their design, and hence they are known as precision inspection apparatuses. Projectors and Toolmaker's microscope are made to the highest possible standard and represent high constructive skill and ingenuity in design. The inspection operation and dimensional measurement that can be carried out with optical projector are similar to engineering microscope in many ways. However, there are still differences between these two families of optical measuring instruments. Microscopes are intended primarily for tool room and gage room applications and require certain degree of skill in operation. On the other hand, projectors are basically production-oriented instruments in shop floor by machine tool operators. Optical projectors are not adaptable to various types of special accessories designed for microscope. But they provide application advantages in many other respects in comparison to the capabilities of engineering microscopes.

In this unit, we will discuss the principle of the projection techniques used in various projectors and toolmaker's microscope. Few applications of these will also be discussed. We will also discuss constructional details in brief.

Objectives

After studying this unit, you should be able to

- familiarise yourself with different types of projectors, their uses and advantages, and
- understand the principle and the working of a toolmaker's microscope.

7.2 PRINCIPLES OF OPTICAL PROJECTORS

The need of observing a magnified image of an object from a convenient distance has given rise to the construction of projectors. Unlike microscope where observation and

measurement of objects with the aid of optical magnification are limited to viewing through an ocular, projector uses project magnified image of the object on a glass screen. As a result visual impressions become a physical reality insofar as the dimensions and forms can be directly compared to the physical master components.

The first generation optical projectors were developed after World War I, for the purpose of checking the form of screw threading tool. These projectors had a number of inherent disadvantages like screen was too far away from the operator for the convenient comparison of the shadow image with a master chart. Moreover, they required dark room for viewing. Later, these disadvantages were eliminated by enclosing the whole system in housing and shielding the screen. The distance of the screen from the operator was reduced by inserting mirrors into the path of the projected shadow to reflect the image into the receiving screen in front of the operator.

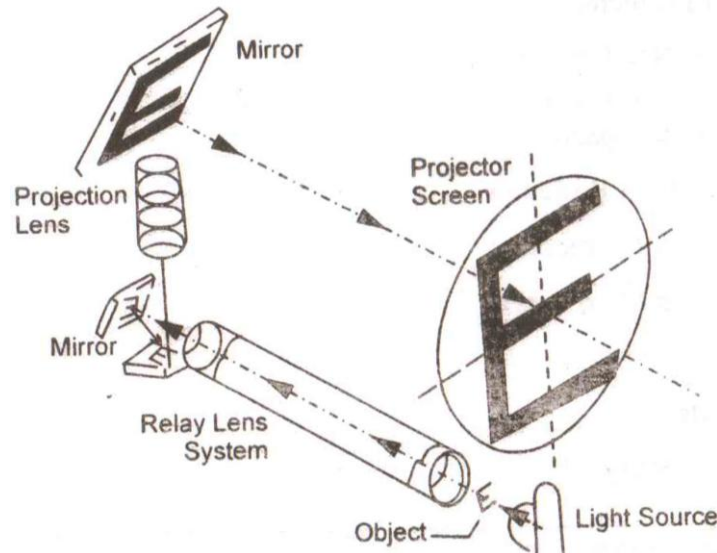

Figure 7.1 : Schematic View of the Optical System in a Typical Projector

7.2.1 Parts of a Projector

The primary purpose of a projector is to produce undistorted magnified shadow image or reflected image of an object on a screen. To accomplish this, any projector should comprise the following basic elements.

Source of Light

Light source is usually a powerful lamp up to 1000 watts or more. Generally, tungsten filament lamp is used for illumination. However, it is replaced by high-pressure mercury lamp when specific measurement has to be made. It produces steady light without flickering. The light source has to be designed with consideration of several factors to avoid harmful heat transfer to the optical system and operating elements of the projector. Therefore, the lamp house is usually mounted externally with a powerful blower fan. It also has special heat absorbing glass filters to keep back the heat rays that might affect the dimensional stability of the object. Two types of light source systems are commonly employed :

Shadow Projection Light Source System

In this system, light rays originating from the light source hit the object, whose physical body creates a shadow bounded by the actual contour of the object when viewed in the direction of light rays. This shadow is then magnified by the lens system and projected on the viewing screen.

Figure 7.1 shows a schematic diagram of such type of system. In this particular system, an auxiliary element, a relay lens is used to transfer the shadow on the projecting lenses.

Reflection Projection Light Source System

In this system, light source illuminate the front side of the object, which faces the lens system. The lens system receives reflected light, which is magnified and projected on the screen as the object image.

Modern optical projectors are equipped with light switches with a provision to regulate the light intensity. This enables the production of best level of illumination for any particular magnification.

Collimating or Condensing Lens

These lenses are the parts of a projector, which refract the light into a beam with parallel rays of almost uniform intensity on the entire area of object illumination. They are fixed in the lens housing and are situated nearest to the light source. Therefore, the glass used for collimating lens must be heat resistant. For special applications of projectors, like photo-elastic stress analysis provisions are made in the collimators to mounting of polarizing filters.

Projection Lens

The projection lens system magnifies and transmits the object contour or image resulting from the collimated parallel light rays. The image formed on the screen should be erect and unreversed. Different types of lens arrangement are possible according to need and application. For plainer type of optical projectors, the magnifying lens system is interchangeable lens system. For complicated application like in measuring machine, the lens system consists of several lenses with different magnification. They can be adjusted manually or with power drives. The lens system must be capable of giving clear definition of the object. Therefore it is coated for extra light transmission.

Screen

The projected image of the object appears and is displayed on the screen for inspection. It is made of ground glass, with finely grained texture, to provide a bright, glare-free image. The screen must present an image easy to measure with accuracy without causing fatigue to the operator. The brightness of the image must be uniform over the full area of the screen. It must permit observation of the image without distortion, when viewed by a group at different angles. Depending on the design of the optical system, the position of the screen may be exactly horizontal, vertical or tilted at certain angle.

7.2.2 Magnification of a Projector

The magnification of a projector is defined by the following formulae :

$$\text{Lens magnification (m)} = \frac{\text{Screen Diameter}}{\text{Field Diameter}}$$

The most frequently available magnifications in optical projectors are 5X, 10X, 20X, 25X, 30 X, 31.25X, 50X, 62.5X, 100X, and 125X. Since different magnification is required depending on the object, projectors are built with optical system that permits interchanging the lenses. The two aspects that must be noted in magnifying an image are

- The higher the magnification, the more is the intricate details of the object, and
- The lower is the magnification, the larger will be the area that can be projected on the screen.

SAQ 1

- (a) What are the various components of a projector?
- (b) Define magnification of a projector.
- (c) The magnification of a projector is 25X. If the screen diameter is 1m, what is the maximum diameter of the job, whose measurement is possible?

7.3 TYPES OF PROJECTOR

According to construction and shape, projectors can be categorized in several types. The basic mode of operation of all these projectors is same. They differ in the techniques used in projection and light source used for projection. The following are the most common projectors in use.

7.3.1 Horizontal Projector

This was designed by National Physical Laboratory and is the earliest form of projector. It consists of a base casting. A lens system and a sliding carriage carrying the object to be projected are mounted on the base. The carriage slides parallel to the optical axis and this enables the object to be focused. The disadvantage with this is that there is only one plane normal to the optical axis in which all sharply focused parts of the object must lie. The lamp housing and the collimating lens are carried on two bars arranged to pivot about a vertical axis passing through the projection lens to enable the collimating beam to be inclined to the optical axis for projection of screw thread. Its magnification is of the order of 50 X.

7.3.2 Vertical Projector

The horizontal comparator is not suitable for rapid inspection of small work and also occupies more space. In vertical projector, the optical axis from the projection lens rises vertically and is reflected down again from the mirror on a small horizontal screen. It has the advantage of occupying less floor space, the work is near the screen, and therefore the size of the screen is also less. The horizontal screen enables the people to stand and view the image conveniently. The profile drawing and template can also be laid down conveniently without the necessity of fastening with tape etc. The illumination is obtained by carbon arc in conjunction with a long focus collimator.

7.3.3 Cabinet Projector

The various advantages and conveniences of projection as a method of inspection have led to the development of a self-contained type of projector. It is now available in compact form and can be used anywhere without special arrangements for the erection or radiation of general lighting. Some of the commercially available projectors of this type are discussed below.

Bausch and Lomb Projector

The various parts of a Bausch and Lomb projector is shown in Figure 7.2. The eliminating system consists of a light source, a tungsten arc lamp. The glowing element in the lamp is a small cylinder of tungsten, which is heated to incandescent by electron bombardment. It is enclosed in a ventilated lamp house. The light from the lamp passes to a system of lenses called achromatic condenser. With a single lens condenser, the screen image consists of various colours. So to get rid of them, each lens assembly is composed of two kinds of glasses. The parallel beam of light from the condenser is then transmitted to the illumination mirror, which sends them vertically upward, through the glass stage plate in the worktable, past the object.

The projection system consists of *projection lens*, *roof prism*, a pair of *image reflectors* and *screen*. The magnification of the projector can be adjusted by changing the projection lens assembly. The adjustment for changing the lens assembly is very easy and accurate. It is done by merely placing the assembly into the bracket. The light travels past the object to the projection lens from which it passes upward to the roof prism. The function of the roof prism is to direct the beam of light horizontally towards the back of the projector to assist in the projections of the image so that its aspects presented to the observer are correct. From the roof prism, light passes to two optically flat reflectors that change the direction of the beam of light and direct it horizontally to the screen.

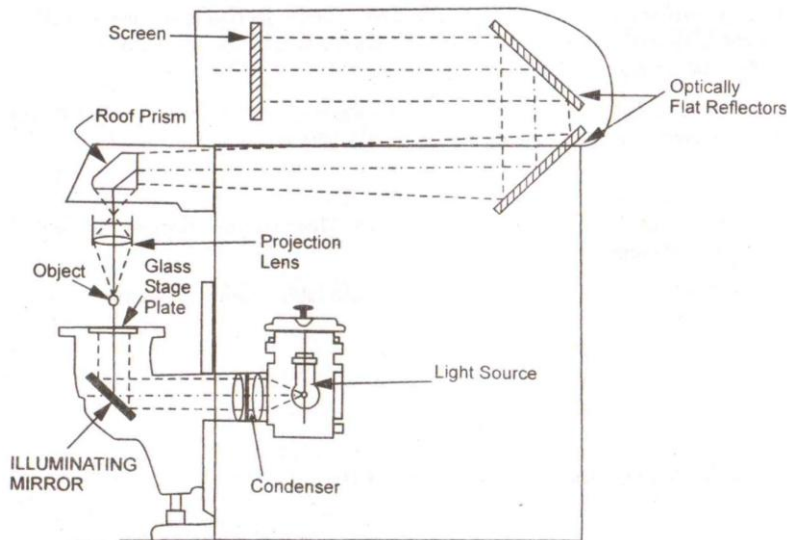

Figure 7.2 : Optical System of Bausch and Lomb Projector

When an observer looks at the image, he will find the image as erect and its aspects same as that of the object, i.e. movement of an object in any direction on the worktable will cause a corresponding travel of the image. If the object is moved to right or back, a corresponding movement of image to the right or up will be observed.

Societe Genevoise Projector

This is a comprehensive measuring machine intended for the measurement of objects like gear cutting hobs and other complex tools. The work is held in the centres. For the spacing of every tooth, there is a headstock fitted with a dividing head. The longitudinal movement of the carriage is measured by a precision scale and microscope. The various type of indicating units can be set up for radial, longitudinal and transverse measurements, thus covering the measurement of any complicated shape. In this way in a gear hob cutter, the flute spacing, tooth relief concentricity etc. can directly be checked and the form and the angle of teeth can be measured by projection.

Screw Thread Projection

In projection of a thread, a part of the helix always crosses over in front of each part of the thread and interferes with the direct passage of the rays. There are two methods to overcome this. First, by inclining the axis of the thread at an angle equal to the helix angle so that the collimated beam gazes the thread without appreciable interference. Secondly, by inclining the collimated beam to the helix angle by swiveling the lamp housing about a vertical axis passing through the projection lens. The image formed on the screen is that of a plane cutting the thread normal to the helix and lying at an angle to the axis. In the second method, the axis of the threads lies in the plane of the axis and hence defined profile is produced without loss of field and definition. The projection lens must be well designed; otherwise only small helix angle can be dealt with. In case of first system, the arrangement is very simple.

It is found that difference in profile between the two methods is generally difficult to be detected and hence first method, which is very convenient, is used.

SAQ 2

- (a) What are the various types of projectors? Describe the principle used in each of them.
- (b) Give the names of some commercially available cabinet projectors.

7.4 APPLICATIONS OF PROJECTOR

Optical projectors are very versatile and reliable inspection tool. Initially, they were designed and used by the manufacturer of threading tool. But due to their versatility, the uses did not remain confined to a particular branch of metal working industry. Now a days they have become the indispensable standard instruments in many fields of engineering and fine mechanical production. Additional features, comprising a wide variety of adjustable motions, built in devices, accessories and attachment have improved their versatility manifolds.

The popularity and rapid expansion of projectors may be attributed to the following reasons :

- (i) Growing importance of precision and accuracy in industrial paradigm. Projectors facilitate this to the maximum extent.
- (ii) The added features in the projectors, which enable the observer to take multiple readings reduce inspection time.

A variety of inspection can be made with the help of projectors. Some of their applications have been discussed below. It will give a general idea of the capabilities of optical projectors as a means of inspection and dimensional measurement.

Image Inspection

This is the primary use of projectors. Shadow outline of the image to be inspected is formed on the screen. The image is magnified by projection, reflection or the combination of both.

Inspection by Observation

Surface properties like texture, finish, surface conditions; general contour straightness, consistency of curvature; contact patterns with mating parts are observed by projectors.

Inspection by Comparison to Master Charts

Projected images are compared with the help of screen charts for the inspection of standard forms, e.g. angles, radii, screw threads, gear forms, etc.

Inspection by Direct Measurement on the Screen Image

Linear measurements using graduated rulers or glass scales, angular measurements using drafting or toolmaker's protractor, radii using transparent templates are also done with projectors.

Inspection with Measuring Devices Built into the Optical Projectors

Projectors can be used for measuring the Coordinate table movement (along X and Y axes) by reading the displacement distance on the micrometer heads. For angular measurement, graduated protractors provided in the instruments are used.

Inspection with the Aid of Fixtures and Special Attachments

Adjustment of helix angle to project thread form, transferring dimensions by means of work holding devices and charts with reference points, optical sectioning with special illumination can also be done.

7.5 ADVANTAGES OF PROJECTOR

There are several advantages of optical projectors. Since they vary in size and construction widely, their uses also vary. Some of the advantages of projectors are listed below.

- (i) A single setting of the specimen provides observation, comparison and inspection of several dimensions and form characteristics in a projector.
- (ii) Several people can observe the projected image simultaneously. Thus, projectors are handy tools when images are to be inspected by a group of people.
- (iii) The image can be magnified according to requirement. Thus, dimensions to be inspected individually or their interrelation with other dimensions of the same part can be observed without any additional instruments.
- (iv) Projector provides direct measurements of various lengths and angles. Lengths are measured by graduated rulers and angles by drafting protractors.
- (v) Precise comparison is possible in projectors. Standard comparator charts, specially for repetitive forms such as circular arcs with different radii, angles, thread forms, gear contours can be used on optical projector screen. Such standard charts are made of glass plates.
- (vi) There is no physical contact between the specimen and the measuring instruments in projectors. Thus, specimen to be inspected is free from mechanical distortion or defects. This increases the accuracy in measurement.
- (vii) Unlike the mechanical gauges, which undergo wear and tear due to prolonged uses, measurements by optical projectors are free from wear.
- (viii) Optically obstructed surface elements can be traced by means of projectors. Application of cross-sectioning provides means for the accurate measurement of dimensions, whose inspection by any method other than optical projection is extremely difficult.
- (ix) Greater range of inspection is possible in projectors. For example, the observation of surface characteristics by light reflection, using either normal or oblique illumination, substantially widens the scope of inspection procedure.
- (x) The open screen, commonly at eye level, permits the observation of the image in unrestricted position under more natural conditions than viewing through a microscope eyepiece.
- (xi) The contour of the inspected part can be traced with a pencil by mounting a vellum paper on the glass screen. This serves for future recording.

SAQ 3

- (a) What are the various application of an optical projector?
- (b) List out the advantages of an optical projector.

7.6 TOOLMAKER'S MICROSCOPE

Engineering microscopes designed to satisfy various measuring needs of toolmaker's are known as toolmaker's microscopes. A plain toolmaker's microscope is primarily intended for a particular application. On the other hand, universal toolmaker's microscope is adaptable to an uncommonly wide range of measuring tasks. A toolmaker's microscope is designed for measurements of parts of complex forms, e.g. profile of external threads, tools, templates and gauges. It can also be used for measuring center-to-center distance of holes in any planes, as well as the co-ordinate of the outline of a complex template gauge.

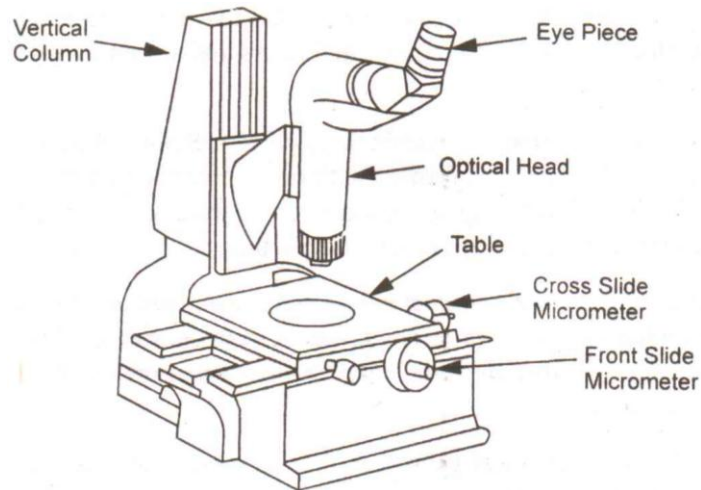

Figure 7.3 : Toolmaker's Microscope

Construction

A general view of the toolmaker's microscope is shown in Figure 7.3. A heavy, hollow *base* accommodates the illuminating unit. On the top surface of the base, the *worktable* is carried, supported on the balls and controlled by *micrometer screws*. Projection from the rear of the base is done through a column, which carries the *microscope unit* and various interchangeable *eyepieces*. A longitudinal section is given in Figure 7.4, which also shows the projection attachment in position. Inspections are made by eye in the normal way, or the projection attachment may be fitted which turns the beam by mirrors to bring up the image on the back of the translucent screen. The magnification given depends on the microscope objective. However, additional magnifying attachments are commonly supplied which facilitate the magnification from 10X to 100X on the projection screen.

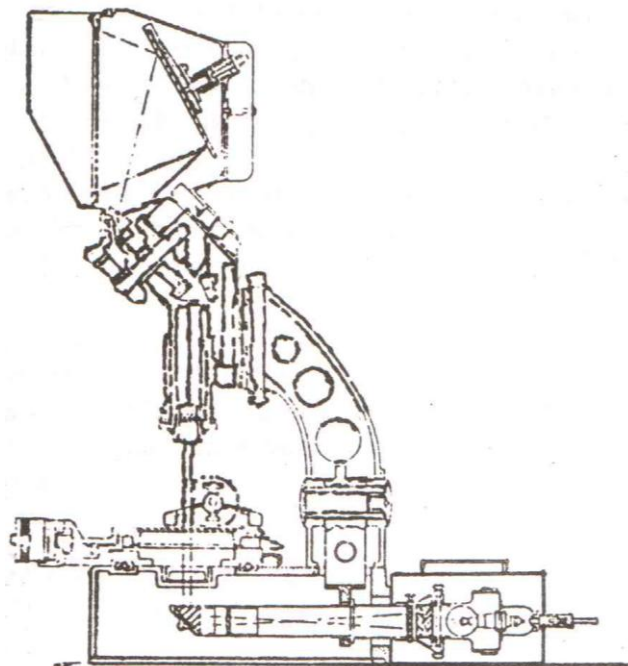

Figure 7.4 : Section of Toolmaker's Microscope

In order to adapt the apparatus to deal with a variety of works, various additional attachments may be fitted to the worktable. The worktable can be made to revolve on the mounting and normally has a central recess hole for accommodating a disc of glass. Flat work may be rested upon the disc of glass. The attachments are available for clamping the work also. Generally, *vee block* and *credit-centre*

adaptations are used for this purpose. Linear movements of the table are controlled by micrometer screws having a movement range of 25 mm and reading to 0.001 mm. The table slide is held against the ends of the micrometer spindles by light spring pressure so that movements greater than the micrometer travel may be controlled by interposing a slip gauge of required dimension between the spindle and the point where it bears against the slide. This method is preferable, even for movements within the range of the micrometers, as it is positive and less liable to error.

There are several detachable and interchangeable eyepiece units. The *protractor unit* is prepared with radial and cross setting lines and protractor. This may be rotated by a knurled screw for setting any of the lines to a projected line of the work image, and readings of the protractor may be made to 1' by means of a scale that divides each degree into 60 parts. The protractor, which is illuminated, is read by eye through the small hole in the projecting eyepiece. This is shown in Figure 7.5.

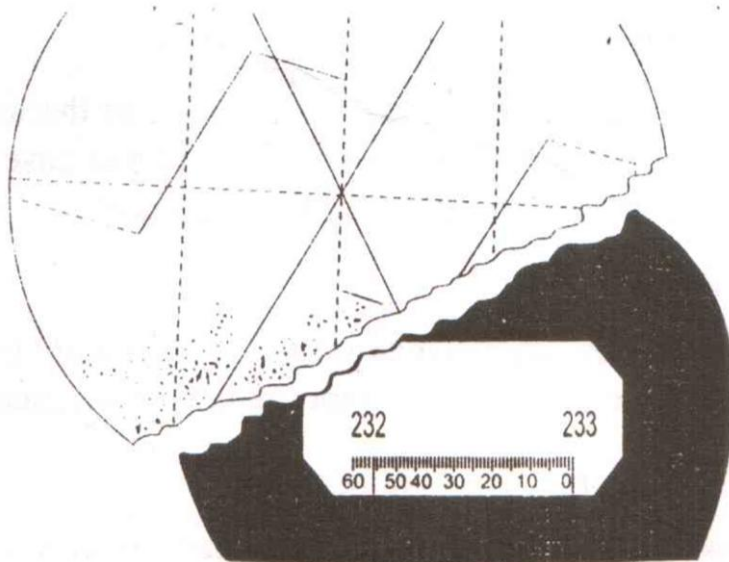

Figure 7.5 : Protractor Unit

Means are provided for setting the worktable axis correctly relative to the protractor for zero reading. The *thread template unit* has selected thread forms arranged round the glass disc in the eyepiece, and this may be rotated to bring any desired thread form into position for comparison with the magnified image of the work. Means are also provided for lining this up with the table and the work diameter so that any thread profile brought into position will occupy the same angular position as the thread image it is to check. A third type of eyepiece is often available. It contains a linear scale and sets of radii, which may be superimposed on holes, or radii projected from the work.

Working

Light from lamp at the extreme right is collimated in the tube connecting the lamp to the center of instrument and is reflected as a parallel beam by the prism at the end of the tube. On its way up, this beam collects the image of the object to be inspected and this enters the microscope. Before the rays reach the eyepiece, it is turned by another prism. This is shown in Figure 7.4.

For the most effective manipulation, the magnified image of the work is viewed through the eyepiece (or is projected), superimposed on a prepared background engraved on glass disk in the eyepiece.

In order to view screws along the helix angle of the thread, the whole of the column unit with the underside illuminating arrangement attached may be swung into the helix angle of the thread. The pivot upon which the column swings may be seen near its base in Figure 7.4.

Most of the uses of this instruments will be on work where the shape of a profile is projected from below, but surface shapes occur such as the edge of a recess, where surrounding metal prevents light passing across the profile. These may be illuminated from above by a special attachment, which then allows the profile to be received in the normal manner, except that the intensity of light will be reduced from that received directly.

Applications

The application of toolmaker's microscopes may be summarized broadly as follows :

Determination of the Relative Positions

It is used for the determination of the relative position of various points on work by measuring the travel necessary to bring a second point to the position previously occupied by the first, and so on.

Measurement of Angles

Measurement of angles is possible in toolmaker's microscopes by using a protractor eyepiece.

Comparison Measurement

A toolmaker's microscopes also do comparisons of thread forms, measurement of pitch and effective diameter. In this case the comparison is done with master profiles engraved in the eyepiece.

Comparison with a Scale

Comparisons of enlarged projected images with a scale tracing fixed projection screen are also done in a toolmaker's microscope.

SAQ 4

- (a) Describe the working principle of a toolmaker's microscope.
- (b) Discuss the application of a toolmaker's microscope.

7.7 SUMMARY

In this unit, different projectors and toolmaker's microscope have been discussed. The unit begins with the discussion of different projectors and their parts. Various applications of it are discussed in the following section. Selection of projectors with different conditions of the objects is also discussed. Advantages of the projectors are also highlighted so that reader can have an idea while selecting a projector. Next to this, construction and the working principle of toolmaker's microscope is described. The unit finishes with the discussion of the various applications of a toolmaker's microscope.

7.8 KEY WORDS

- | | |
|-----------------------------|---|
| Collimating Lens | : The lens used in optical devices, which refract the light into a beam with parallel rays of almost uniform intensity on the entire area of object illumination. |
| Incandescent Light | : It is a kind of lamp in which the light is produced by a thin filament of conducting material. |
| Achromatic Condenser | : A combination of lenses made of different glass, used to produce images free of chromatic aberrations is called achromatic condenser. |

- Projection Lens** : The lens that magnifies and transmits the object contour or image resulting from the collimated parallel light rays for projecting rays of light over a screen. They are also called condensing lens.
- Magnification** : It is defined as the ratio of the screen diameter to the field diameter in a microscope.
- Field Diameter** : It is defined as diameter of the area that can be projected on the screen.
- Bausch and Lomb Projector** : It is a type of cabinet projector designed by Bausch and Lomb Company in which the light source is a tungsten arc lamp.

7.9 ANSWERS TO SAQs

SAQ 1

(c) We know,

$$\text{Magnification, } m = \frac{d_s}{d_f}$$

where, d_s = screen diameter

d_f = field diameter = ?

$$\begin{aligned} \therefore d_f &= \frac{1}{25} \\ &= 0.04 \text{ m} \\ &= 40 \text{ mm} \end{aligned}$$

\therefore The maximum size of the object is 40 mm.