

I can define, identify and illustrate the following terms

leg of a right triangle	short leg	long leg
radical	square root	hypotenuse
Pythagorean theorem	Special Right Triangles	Trigonometry
Reference Angle	Adjacent	Opposite
Sine	Cosine	Tangent

7 Holiday	8 Pythagorean Theorem	9-10 Pythagorean Theorem	11 Isosceles Right Triangles
14 30°-60°-90°	15 Mixed practice	16-17 Trigonometry	18 Trigonometry
21 Holiday	22 Trigonometry	23-24 REVIEW Begin Test	25 TEST

Tuesday, 1/8

Pythagorean Theorem	
1. I can solve for the missing hypotenuse of a right triangle.	
2. I can solve for the missing leg of a right triangle.	
3. I can identify Pythagorean Triples.	
ASSIGNMENT: Introduction to Pythagorean Theorem Worksheet	Grade:

Block day, 1/9 - 10

Pythagorean Theorem, Converse, and Inequalities	
4. I can use the Converse of the Pythagorean Theorem to determine if a triangle is a right triangle or not.	
5. I can determine if a triangle is acute or obtuse using the Pythagorean Inequalities theorem.	
ASSIGNMENT: Pythagorean Theorem Converse and Inequalities Worksheet	Grade:

Friday, 1/11

Isosceles Right Triangles (45°-45°-90°)	
I can solve for the 2 missing sides of an isosceles right triangle.	
ASSIGNMENT: Isosceles Right Triangle Worksheet	Grade:

Monday, 1/14

30°-60°-90° Triangles	
I can solve for the 2 missing sides of a 30°-60°-90°	
ASSIGNMENT: 30°-60°-90° Worksheet	Grade:

Tuesday, 1/15

Mixed Practice	
I can choose the correct method to solve a right triangle problem.	
I can solve problems using Pythagorean Theorem and/or Special Right Triangles.	
ASSIGNMENT: Mixed Practice Worksheet	Grade:

Block day, 1/16-17

Trigonometry	
I can write the trigonometric ratios.	
I can solve problems using trigonometric equations.	
I know the relationships between sine, cosine, and tangent.	
ASSIGNMENT: Introduction to Trig Worksheet	Grade:

Friday, 1/18

Trigonometry	
I can write the trigonometric ratios.	
I can solve problems using trigonometric equations.	
I know the relationships between sine, cosine, and tangent.	
ASSIGNMENT: Introduction to Trig Worksheet	Grade:

Monday, 1/22

Trigonometry	
I can find another trig function, given one.	
I can find multiple pieces of a triangle using trigonometry.	
ASSIGNMENT: More Trig Worksheet	Grade:

Block day, 1/23-24

Review	
I can do all above objectives.	
ASSIGNMENT: Review Worksheet	Grade:

Friday, 1/25

TEST #8: Right Triangles	Test #8
I can demonstrate knowledge of ALL previously learned material.	
TEST #8: Right Triangles	Grade:

Notes: Introduction to Pythagorean Theorem

Previous Knowledge:

- 1) The largest side of a triangle is across (opposite) from the _____.
- 2) The _____ of a right triangle is always across from the _____.
- 3) The Pythagorean Theorem is _____. And c is always used for the _____.

Ex. 1) What variable represents the hypotenuse?

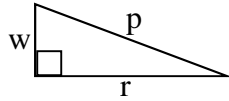

b) If $p = 8$ and $r = 15$ then $w = \underline{\hspace{2cm}}$.

Ex. 2) What variable represents the hypotenuse?

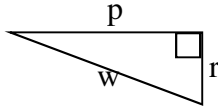

b) If $p = 25$ and $r = 24$ then $w = \underline{\hspace{2cm}}$.

3.

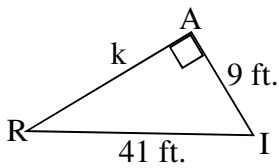

4.

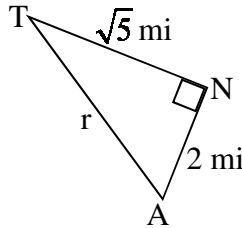

5.

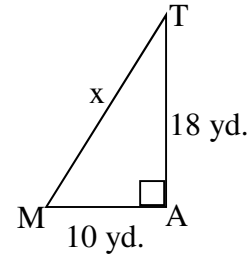

- A) 424 B) $4\sqrt{106}$
 C) $2\sqrt{106}$ D) $106\sqrt{2}$

6. Find the missing side

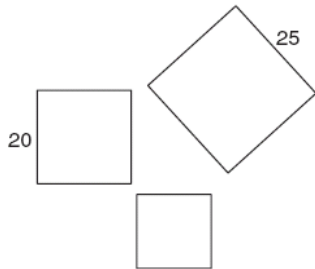

7.

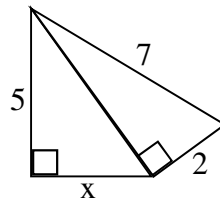

8.

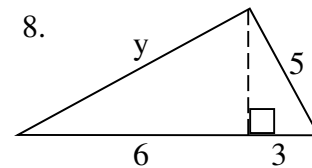

Introduction to Pythagorean Theorem Assignment

Use the Pythagorean Theorem to find the missing length. Give answers to nearest hundredth.

1. $a = 8$ and $b = 6$.

2. $a = 24$ and $c = 28$.

Solve each problem. Round to the nearest hundredths.

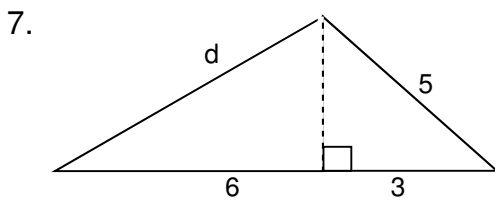
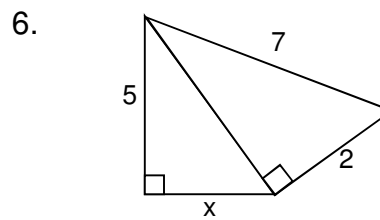
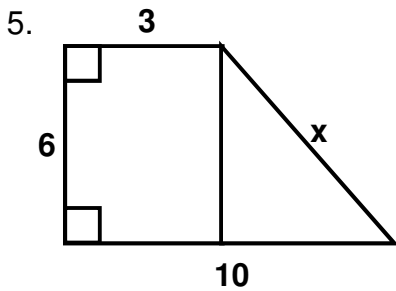
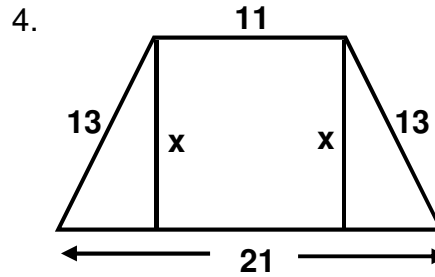
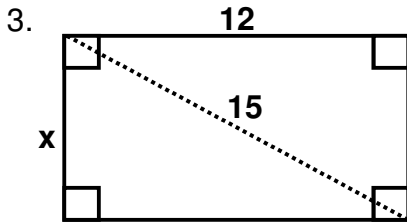

8. The slide at the playground is 12 feet tall. If the bottom of the slide is 15 feet from the base of the ladder, how long is the slide?

+	0	0	0	0	0	0	0
-	1	1	1	1	1	1	1
	2	2	2	2	2	2	2
	3	3	3	3	3	3	3
	4	4	4	4	4	4	4
	5	5	5	5	5	5	5
	6	6	6	6	6	6	6
	7	7	7	7	7	7	7
	8	8	8	8	8	8	8
	9	9	9	9	9	9	9

9. If you place a 16 ft ladder 6 feet from a wall, how high up the wall will it go?

10. A tree broke 6 feet from the bottom. If the top landed 12 feet from the base, how tall was the tree before it broke?

11. Jim headed south 5 miles from his house to the cleaners. From there he headed west to meet his friends. They were at a park 3 miles away. How far would he have to go if he went straight home?

12. There is a restaurant diagonally across a rectangular field from Jeff's dorm. If he followed the roads, he would have to go 2 blocks north and 3 blocks east. Each block is 100 ft long. How much shorter would it be for him if he walked diagonally across the field instead?

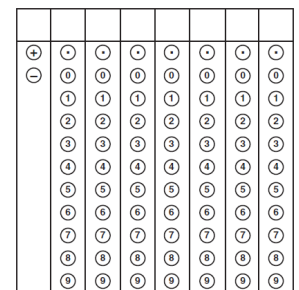
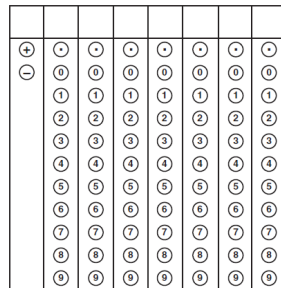

MULTIPLE CHOICE: Find the correct answer for each of the following. Clearly circle your answers. WORK MUST BE SHOWN IN ORDER TO RECEIVE CREDIT.

13. If $\triangle KMP$ is a right triangle formed by
 A. 159 in.²
 B. 129 in.²
 C. 66 in.²
 D. 24 in.²

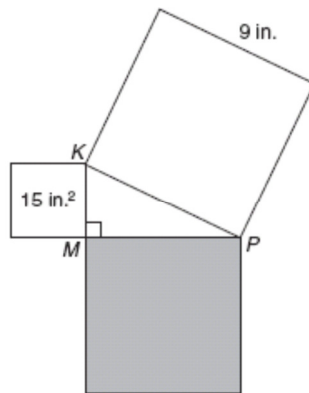

15. The legs of a right triangle are 4 cm and 7 cm long. To the nearest cm, how long is the hypotenuse?

- A. 11 cm
 B. 10 cm
 C. 14 cm
 D. 8 cm

14. The figure below shows three right triangles joined at their right-angle vertices to form a triangular pyramid. Which of the following is the closest to the length of XZ?

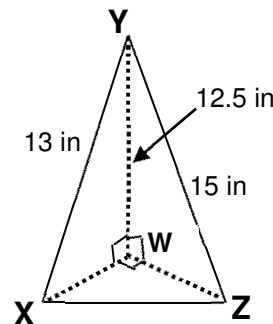

- A. 7 inches
 B. 20 inches
 C. 12 inches
 D. 9 inches

16. What is the height of the triangle?

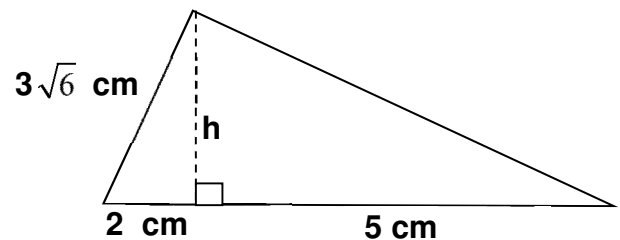

- A. 2 cm
 B. 1 cm
 C. $5\sqrt{2}$ cm
 D. $5\sqrt{10}$ cm

Notes: Pythagorean Theorem Converse and Inequalities

The Pythagorean Theorem states: If a triangle is a right triangle, then the sum of the squares of the lengths of the two legs of the triangle is equal to the square of the hypotenuse.

Write the converse: _____

In your own words what does the converse let you do?

Theorems 5-7-2 Pythagorean Inequalities Theorem

In $\triangle ABC$, c is the length of the longest side.

If $c^2 > a^2 + b^2$, then $\triangle ABC$ is an **obtuse** triangle.

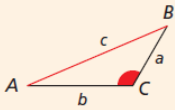

If $c^2 < a^2 + b^2$, then $\triangle ABC$ is an **acute** triangle.

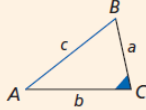

To understand why the Pythagorean inequalities are true, consider $\triangle ABC$.

If $c^2 = a^2 + b^2$, then $\triangle ABC$ is a right triangle by the Converse of the Pythagorean Theorem. So $m\angle C = 90^\circ$.

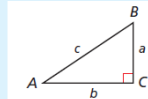

If $c^2 > a^2 + b^2$, then c has increased. By the Converse of the Hinge Theorem, $m\angle C$ has also increased. So $m\angle C > 90^\circ$.

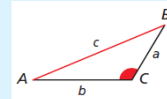

If $c^2 < a^2 + b^2$, then c has decreased. By the Converse of the Hinge Theorem, $m\angle C$ has also decreased. So $m\angle C < 90^\circ$.

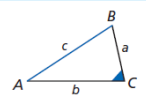

Tell if the measures can be the side lengths of a triangle. If so, classify the triangle as acute, obtuse, or right.

A) 8, 11, 13

B) 5, 7, 10

C) 5, 8, 17

APPLICATION PROBLEMS

Ex1

What is the Question?	What do you need to know?
What other information do you need to know or what do you need to use?	How do you solve the problem?

Which of the following **cannot** be the exact lengths of the sides of a right triangle?

- A. 6, 8, 10
- B. 7, 23, 24
- C. 8, 15, 17
- D. 9, 40, 41

Ex 2

What is the Question?	What do you need to know?
What other information do you need to know or what do you need to use?	How do you solve the problem?

Paulo has a patch of land with the shape below.

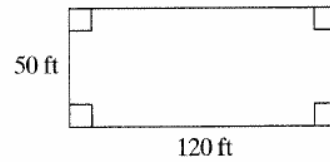

What is the length of the diagonal of the rectangular patch of land?

- F** 10 ft
- G** 50 ft
- H** 130 ft
- J** 120 ft

Ex 3

What is the Question?	What do you need to know?
What other information do you need to know or what do you need to use?	How do you solve the problem?

The floor and walls of Gerald's attic form an equilateral triangle.

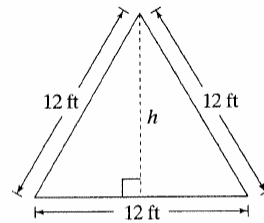

What is the approximate height h of the attic?

- A** 6.0 ft
- B** 10.4 ft
- C** 12.0 ft
- D** 20.5 ft

Ex 4

What is the Question?	What do you need to know?
What other information do you need to know or what do you need to use?	How do you solve the problem?

A yield sign is in the shape of an equilateral triangle. Each side is 36 inches. Which of the following measurements best represents the area of the yield sign?

- a) $\frac{1}{2}(36)(18\sqrt{3})$
- b) $(36)(18)$
- c) $\frac{1}{2}(36)(36)$
- d) $\frac{1}{2}(36)(36)(\sqrt{3})$



Pythagorean Theorem Converse and Inequalities Assignment

Determine if a triangle can be formed with the given lengths. If so, classify the triangle by angles.

1. 7, 20, and 12 YES or NO Classify:

2. 15, 8, and 17 YES or NO Classify:

3. 12, 10, and 8 YES or NO Classify:

4. 20, 8, and 19 YES or NO Classify:

5. 16, 30, 34 YES or NO Classify:

6. 80, 71, and 5 YES or NO Classify:

Find the indicated length.

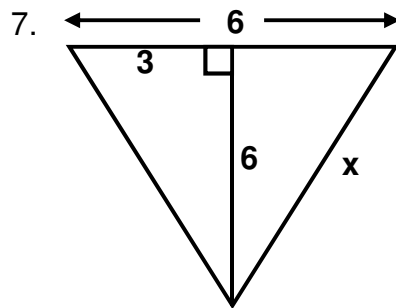

8. A rectangle has a diagonal of 2 and a length of $\sqrt{3}$. Find its width.

9. Find the length of a diagonal of a square with perimeter 16.

+	0	0	0	0	0	0	0	0
-	0	0	0	0	0	0	0	0
	1	1	1	1	1	1	1	1
	2	2	2	2	2	2	2	2
	3	3	3	3	3	3	3	3
	4	4	4	4	4	4	4	4
	5	5	5	5	5	5	5	5
	6	6	6	6	6	6	6	6
	7	7	7	7	7	7	7	7
	8	8	8	8	8	8	8	8
	9	9	9	9	9	9	9	9

10. If you had a 20 ft ladder, how far away from a building would you have to place the bottom to reach a window 15 feet up?

+	0	0	0	0	0	0	0	0
-	0	0	0	0	0	0	0	0
	1	1	1	1	1	1	1	1
	2	2	2	2	2	2	2	2
	3	3	3	3	3	3	3	3
	4	4	4	4	4	4	4	4
	5	5	5	5	5	5	5	5
	6	6	6	6	6	6	6	6
	7	7	7	7	7	7	7	7
	8	8	8	8	8	8	8	8
	9	9	9	9	9	9	9	9

11. Jenny has a rectangular shaped back yard. It is 15 feet wide and 23 feet diagonally. If she wants to plant trees 2 feet apart all the way around her yard, how many trees would she need?

12. A twelve foot pole broke 7 feet from the top. How far from the base of the pole did the top land?

MULTIPLE CHOICE: Find the correct answer for each of the following. Clearly circle your answers. Work must be shown in order to receive credit.

13. Which of the following sets of numbers is a Pythagorean triple?

- A. 9-12-18 B. 7-24-26
C. 9-40-41 D. Not Here

14. If 24 and 40 are two of the three numbers of a Pythagorean triple, what is the third number?

- A. 48
B. 16
C. 32
D. 64

15. Refer to the right triangle shown below. Find the value of 'x'.

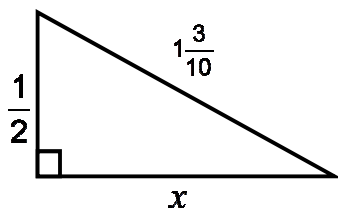

- A. 1
B. $1\frac{1}{5}$
C. $1\frac{3}{5}$
D. 2

16. Use the Pythagorean theorem to find the figure that is a right triangle.

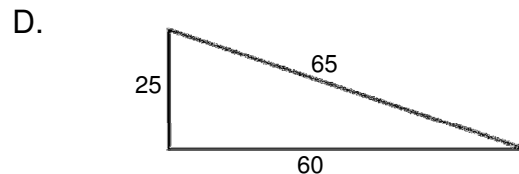
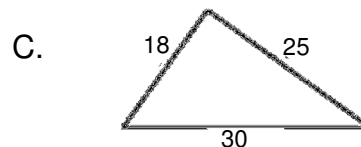
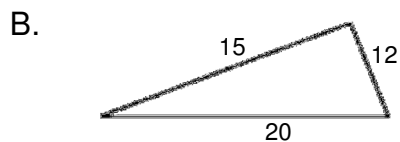
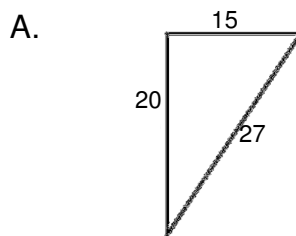

NOTES: Isosceles Right Triangles

FROM STAAR
CHART

45° - 45° - 90° triangle

A diagonal of a square divides it into two congruent

_____.
_____. Since the base angles of an isosceles triangle are _____, the measure of each acute angle is _____°. So another name for an isosceles right triangle is a 45°-45°-90° triangle.

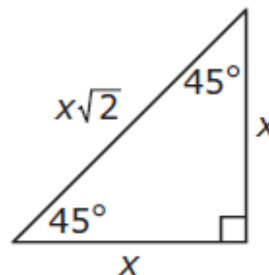

A 45°-45°-90° triangle is one type of _____.

Example 1A: Finding Side Lengths in a 45° - 45° - 90° Triangle

Find the value of x .

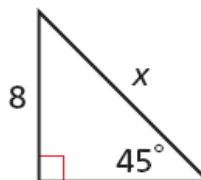

Example 1B:

Find the value of x .

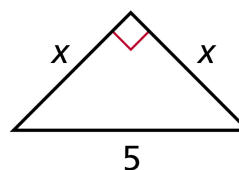

Example 2:

Jana is cutting a square of material for a tablecloth. The table's diagonal is 36 inches. She wants the diagonal of the tablecloth to be an extra 10 inches so it will hang over the edges of the table. What size square should Jana cut to make the tablecloth? Round to the nearest inch.

Name: _____ Period: _____

Isosceles Right Triangles Assignment

I. Fill in the length of each segment in the following figures.

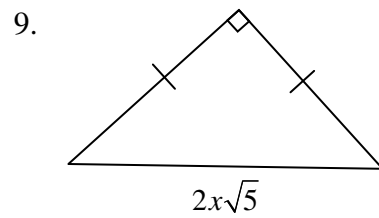
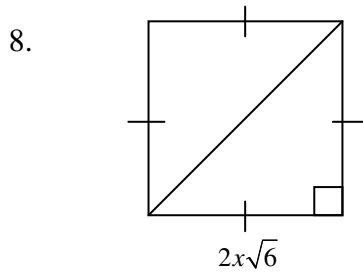
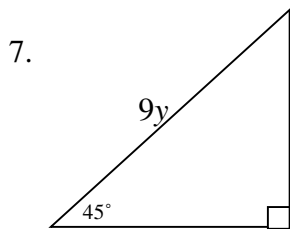
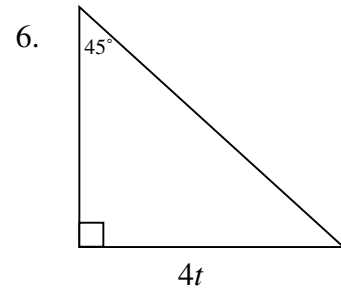
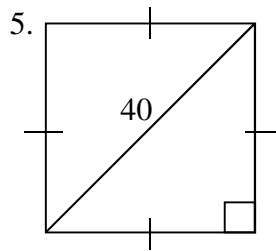
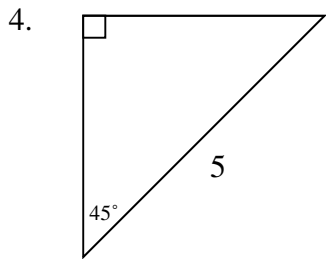
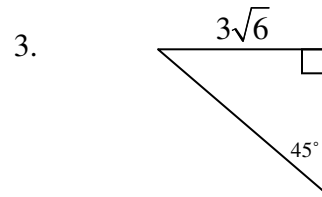
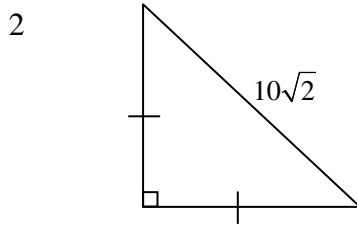
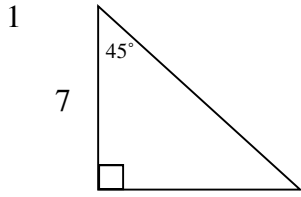

16. Sam has a square backyard divided into 2 sections along the 40 foot diagonal. One of these sections is used as a garden. What is the approximate **area** of the garden?

17. A guy wire supporting a radio tower is positioned 145 feet up the tower. It forms a 45° angle with the ground. About how long is the wire?

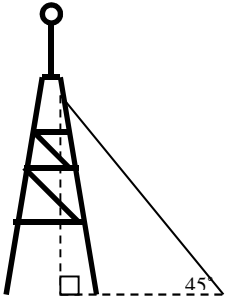

18. Find the perimeter and area of a 45° - 45° - 90° triangle with a hypotenuse length 12 inches.

20. This triangle loom is made from wood strips shaped into a 45° - 45° - 90° triangle. Pegs are placed every $\frac{1}{2}$ inch along each leg. Suppose you make a loom with an 18-inch hypotenuse. Approximately how many pegs will you need?

21. Find the value of x in simplest radical form.

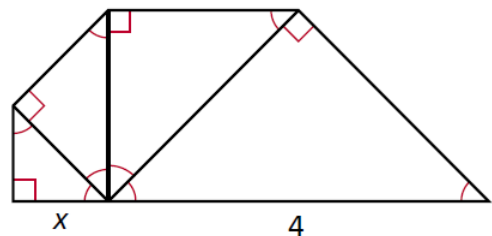

24. Given $AC = 10$, find BX in simplest radical form.

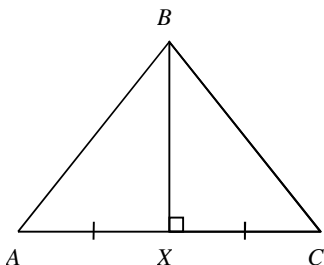

FROM STAAR
CHART

Notes: 30° - 60° - 90°

A 30° - 60° - 90° triangle is another

_____. You can use an

_____ triangle to find a relationship

between the lengths.

$30^\circ - 60^\circ - 90^\circ$ triangle

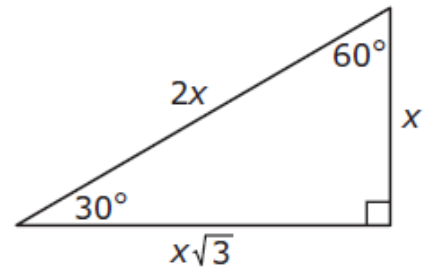

Example 1A: Finding Side Lengths in a 30° - 60° - 90° Triangle

Find the values of x and y . Give your answers in simplest radical form.

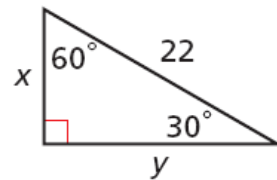

Example 1B:

Find the values of x and y . Give your answers in simplest radical form.

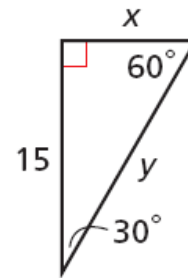

Example 1C:

Find the values of x and y . Give your answers in simplest radical form.

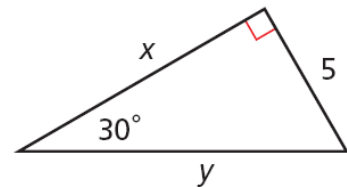

Example 1D:

Find the values of x and y . Give your answers in simplest radical form.

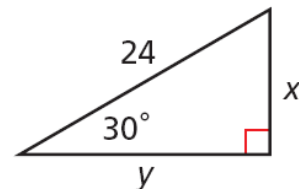

Name: _____ Period: _____

30°-60°-90° Triangles Assignment

Fill in the blanks for the special right triangles.

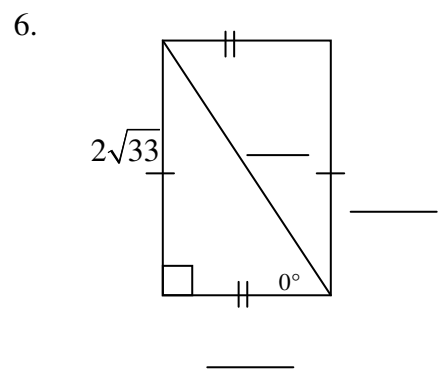
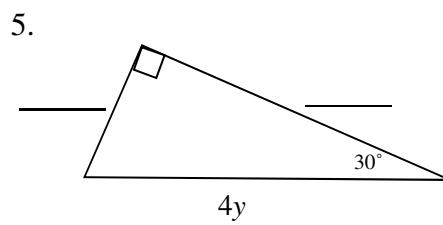
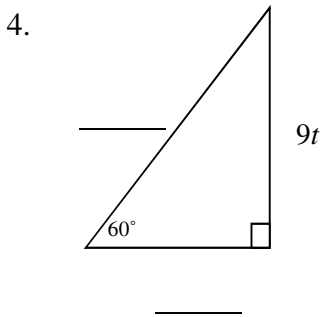
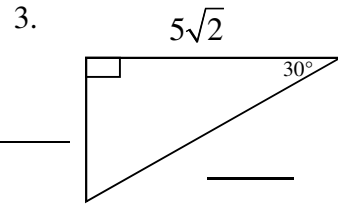
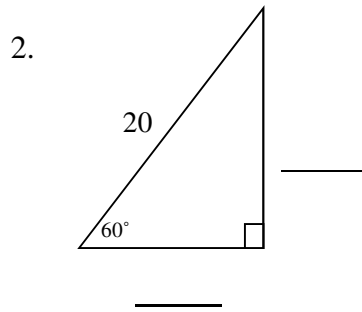
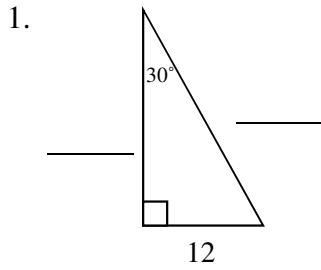

7. $\triangle RJQ$ is equilateral.

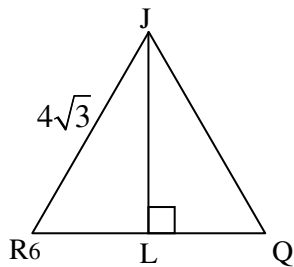

- JQ = _____
- RL = _____
- LQ = _____
- JL = _____

8. $\triangle ABC$ is equilateral.

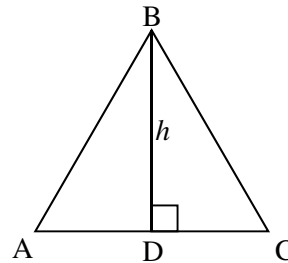

- AD = _____
- DC = _____
- AB = _____
- BC = _____

21. The hypotenuse of a 30-60-90 triangle is $12\sqrt{2}$ ft. Find the **area** of the triangle.

22. Find the perimeter and area of a 30° - 60° - 90° triangle with hypotenuse length 28 centimeters.

24. Find the perimeter and area of an equilateral triangle with height 30 yards.

25. A skate board ramp must be set up to rise from the ground at 30° . If the height from the ground to the platform is 8 feet, how far away from the platform must the ramp be set?

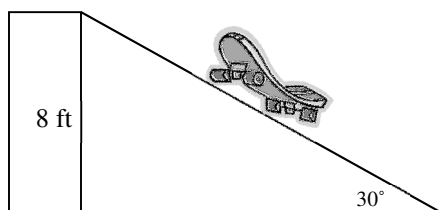

26. Find the value of x .

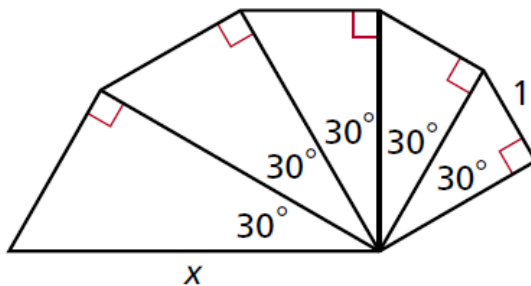

Name: _____ Period: _____

Mixed Practice Assignment

I. For each problem:

- 1) Determine if you should use Pythagorean Theorem, $30^\circ-60^\circ-90^\circ$, or $45^\circ-45^\circ-90^\circ$
- 2) Show work and find all the missing segment lengths

1. Use: _____

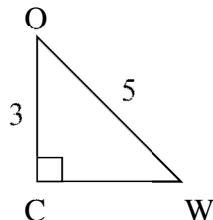

2. Use: _____

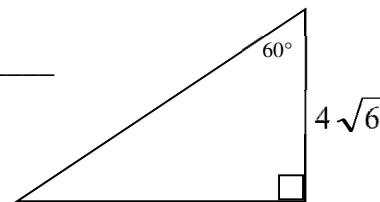

3. Use: _____

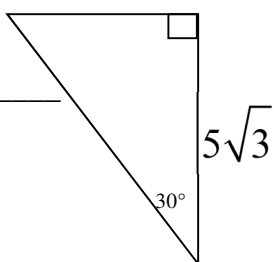

4. Use: _____

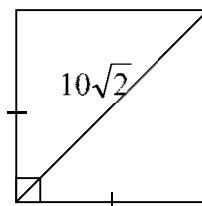

5. $\triangle ABC$ is equilateral with perimeter 36y units. Find the length of each side and the height.

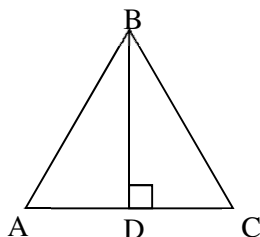

Use: _____

6. **C is the center of a regular hexagon. Find the length of each side.

Use: _____

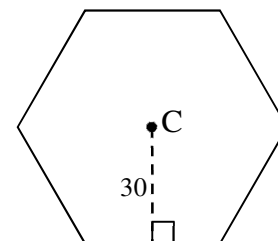

Hexagons are made of 6 equilateral triangles.

7 When viewed from above, the base of a water fountain has the shape of a hexagon composed of a square and 2 congruent isosceles right triangles, as represented in the diagram below.

Which of the following measurements best represents the perimeter of the water fountain's base in feet?

- | | |
|---------------------------------|---------------------------------|
| A $(20 + 20\sqrt{2})$ ft | C $(20 + 20\sqrt{2})$ ft |
| B $(20 + 20\sqrt{2})$ ft | D $(20 + 20\sqrt{2})$ ft |

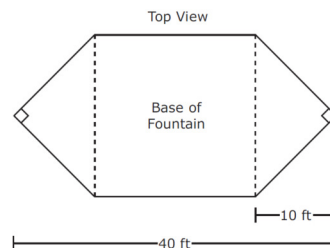

- 8 Dante has a square yard with an area of 81 ft^2 . He plants grass in one half of the yard as shown. What is the perimeter of the grass section?

Dante's Yard

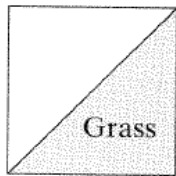

- 9 A triangular pathway in a park is shown below. What is the approximate total length of the path (the perimeter of the triangle)?

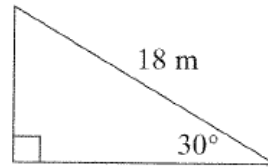

- 10 Alex has a square garden in his back yard. If the garden has a diagonal of 18 inches, what is the area of Alex's square garden?

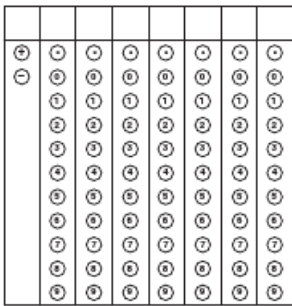

11. $\triangle FGH$ is an equilateral triangle. Which value is closest to the perimeter of $\triangle FGJ$?

- A 39 in
B 52 in
C 62 in
D 66 in

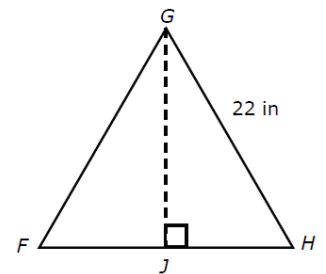

12. Nicole is creating a support in the shape of a right triangle. She has a 92 cm-long piece of wood, which is to be used for the hypotenuse. The two legs of the triangular support are of equal length. Approximately how many more centimeters of wood does Nicole need to complete the support?

- A 130 cm B 184 cm C 260 cm D 276 cm

13. Two identical rectangular doors have glass panes in the top half and each bottom half is made of solid wood. If 1 meter is approximately equal to 3.28 feet, what is the approximate length of x in feet?

- A 5.3 feet C 2.6 feet
B 8.5 feet D 7.1 feet

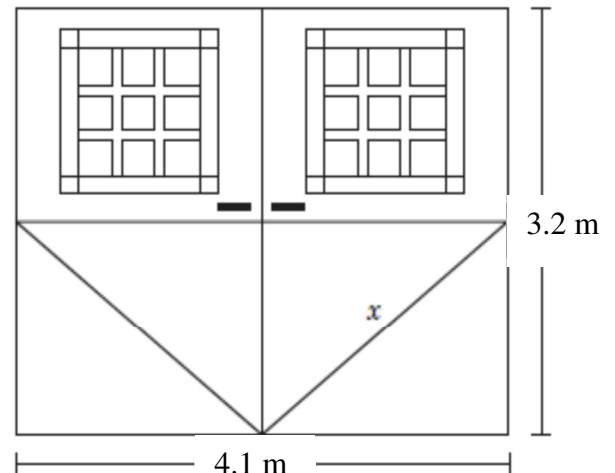

14. Which of the following could be the side lengths of 45°-45°-90° triangle?

A 2 in, 4 in, 2 2in

B 2 in, 4 in, 2 3in

C 2 in, 2 in, 2 2in

D 4 in, 4 in, 4 3 in

15. If a tree casts an 8-meter shadow, and the angle from the ground to the tree is 30°, what is the approximate height of the tree?

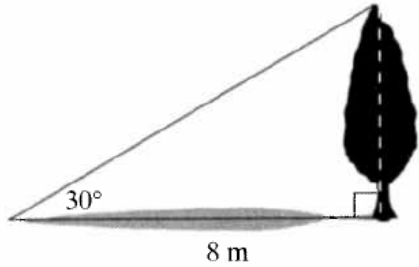

A 4.6 m

C 13.7 m

B 6.3 m

D 16 m

16. What is the approximate perimeter of triangle ABC?

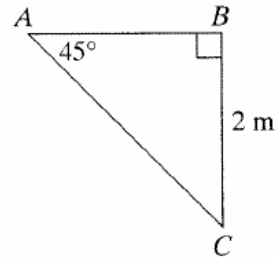

F 2.0 m

H 5.4 m

G 4.0 m

J 6.8 m

17. What is the area of triangle DEF?

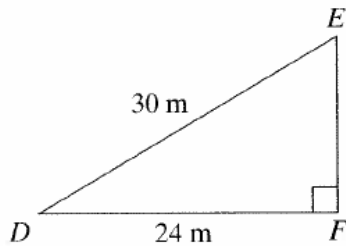

A 216 m²

C 432 m²

B 360 m²

D 720 m²

18. A cube with side lengths of 4 inches is shown below. How could you find the length of d , the diagonal of the cube?

A $\sqrt{4^2 + (4\sqrt{3})^2} = d^2$

B $\sqrt{4^2 + (4\sqrt{3})^2} = d$

C $\sqrt{4+4} = d^2$

D $\sqrt{4+4\sqrt{3}} = d^2$

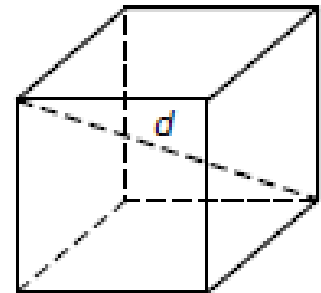

19. Jenna is flying a kite on a very windy day. The kite string makes a 60° angle with the ground. The kite is directly above the sandbox, which is 28 feet away from where Jenna is standing. Approximately how much of the kite string is currently being used?

A 56 feet

B 48.5 feet

C 40 feet

D 14 feet

Notes Introduction to Trig

The mathematics field called Trigonometry is the study of _____ triangles and the ratios of the sides.

Each angle of a right triangle has a unique decimal value for each trigonometric ratio. Your calculator has these tables memorized for you. Find the SINE, COSINE and TANGENT buttons on your calculator.

1) Press _____ and make sure the _____ selection is highlighted. Always check that your calculator is in DEGREE mode. You are responsible to check.

2) Press the Trigonometric function you would like followed by the measure of the angle. **Round to the nearest hundredth.**

Ex 1. $\sin 35^\circ =$ _____

Ex 2. $\cos 18^\circ =$ _____

Ex 3. $\tan 87^\circ =$ _____

If you are given the ratio and asked for the angle, you just use the ratio backwards. Your calculator needs to be told to do this.

Write the keys you will press and then write the angle to the nearest degree.

Ex 7. $\sin x^\circ = \frac{8}{17}$ $x^\circ =$ _____

Ex 8. $\tan x^\circ = 1.875$ $x^\circ =$ _____

Ex 9. $\cos x^\circ = \frac{1}{2}$ $x^\circ =$ _____

There are 3 of trigonometric relationships that we study.

- Sine is the ratio of the _____ side to the _____.
- Cosine is the ratio of the _____ side to the _____.
- Tangent is the ratio of the _____ side to the _____ side.

The _____ NEVER changes, but _____ and _____ are dependent on the _____ used. The _____ angle is NEVER used.

The three sides of the triangles are referred to as Hypotenuse (H), Adjacent (A), and Opposite (O). Label each side of each triangle using angle W as your reference.

Ex 1.

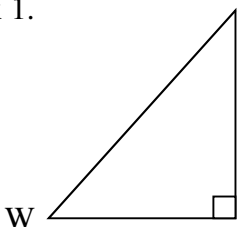

Ex 2.

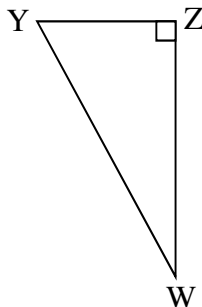

Ex 3.

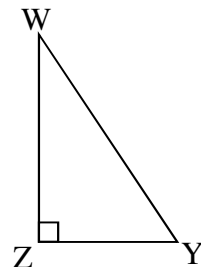

To help you remember these relationships, you can use the phrase _____ .

The trigonometric ratios are written in an equation form. (**Hint: Write these ratios at the top of EVERY page you are working on.)

Sine $x^\circ =$ _____

Cosine $x^\circ =$ _____

Tangent $x^\circ =$ _____

USE THE TRIANGLE AT THE RIGHT to determine the following trigonometric ratios.

Ex 4. $\sin 40^\circ =$

Ex 5. $\sin a^\circ =$

Ex 6. $\cos 40^\circ =$

Ex 7. $\cos a^\circ =$

Ex 8. $\tan 40^\circ =$

Ex 9. $\tan a =$

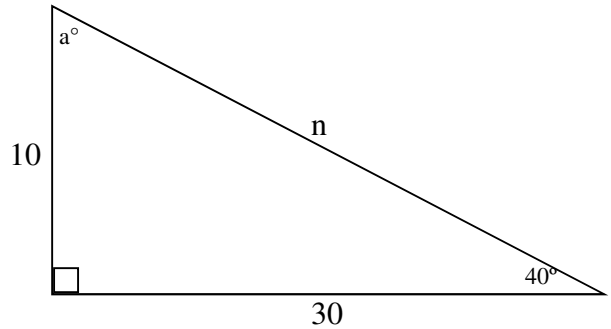

Use the triangle at the right to write all of the following trigonometric equations.

From 72°

From 18°

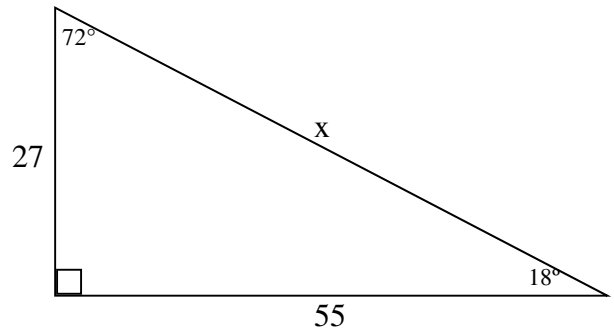

Use Trigonometric Ratios to Solve for Missing Sides and Angles

- 1) Determine which Trig Ratio will fit your information.
- 2) Set up the Trig Ratio
- 3) Round to the nearest degree if it is an angle and round to the nearest hundredth for sides.

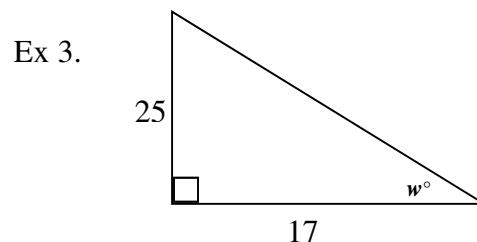
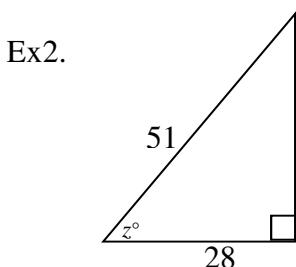
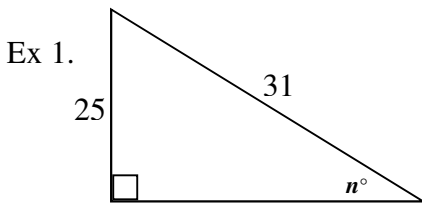

Ex 4.

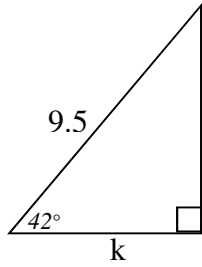

Ex 6.

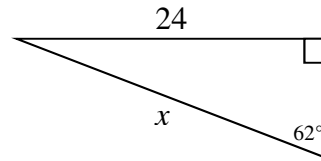

Ex 5.

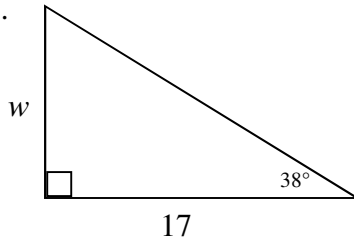

Angle of depression - _____

Angle of elevation - _____

Ex 1. Angie looks up at 25 degrees to see an airplane flying toward her. If the plane is flying at an altitude of 3.5 miles, how far is it from being directly above Angie?

Picture:

Equation:

Solution:

Ex 2. A six foot vertical pole casts a shadow of 11 feet. What is the angle of elevation with the ground?

Picture:

Equation:

Solution:

Ex 3. Lauren is at the top of a 15 m lookout tower. From an angle of depression of 25°, she sees Evan coming toward her. How far is Evan from the base of the tower?

Picture:

Equation:

Solution:

Name _____ Period _____

Introduction to Trig Worksheet

Write down what buttons you would push to get the answer for the following problems. Do not forget to include checking the mode. Then answer the problems.

1. $\sin 40^\circ =$ _____

2. $\tan x^\circ = \frac{5}{7.5}$ $x^\circ =$ _____

The three sides of the triangles are referred to as Hypotenuse (H), Adjacent (A), and Opposite (O). Label each side of each triangle using angle D as your reference.

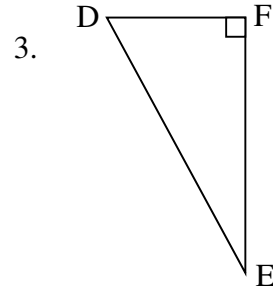
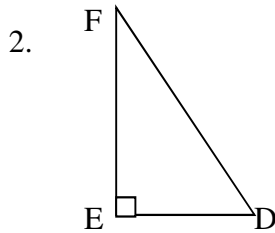
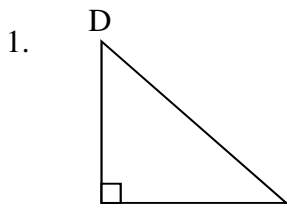

Use the triangles below to write all 6 trig equations from the two acute angles.

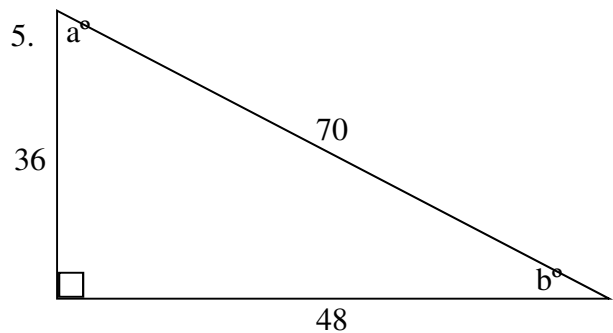
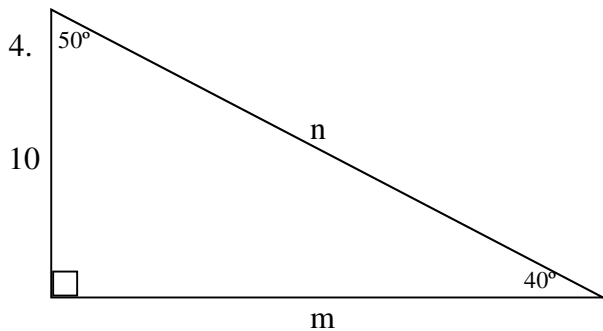

Set up and Solve for variable – round angles to the nearest degree and sides to the nearest hundredths.

6. $x =$ _____

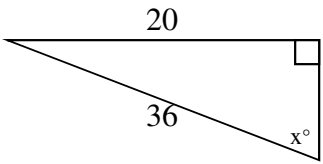

7. $n =$ _____

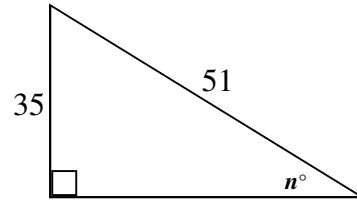

8. $z =$ _____

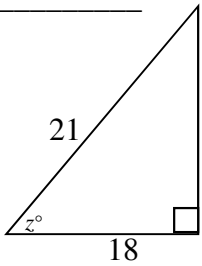

9. $w =$ _____

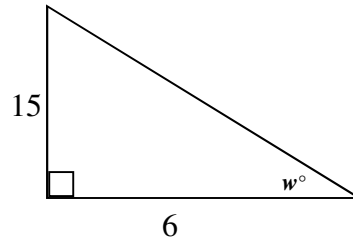

10. $z =$ _____

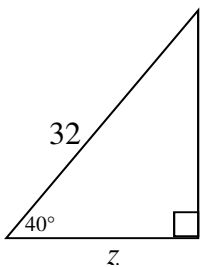

11. $x =$ _____

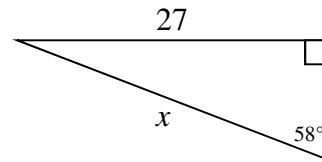

12. $w =$ _____

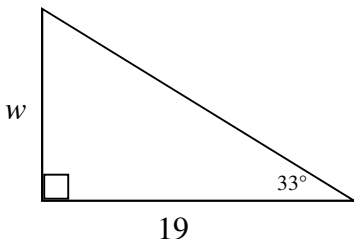

13. $k =$ _____

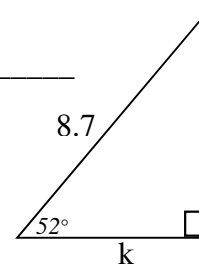

14. $d =$ _____

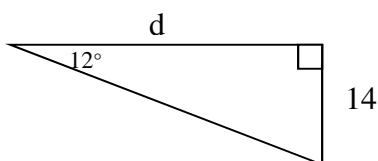

15. $w =$ _____

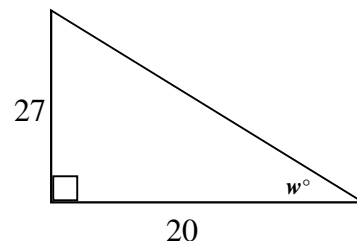

1. A kite is flying at an angle of 63° with the ground. If all 250 feet of string are out, and there is no sag in the string, how high is the kite?
2. A 30 foot tree broke from its base and fell against a house. If the tree touches the house at 21 feet, what angle is the tree forming with the house?
3. A tree casts a shadow of 28 m. The elevation of the sun is 49° . How tall is the tree?
4. Joey is putting up an antenna. At the 30 foot mark, he attaches a 50 foot guy wire. What angle does the guy wire form with the antenna?
5. A freeway entrance ramp has an elevation of 15° . If the vertical lift is 22 feet, what is the distance up the ramp?
6. A person at the top of a cliff 100 feet tall sees Gilligan's boat. His sighting of the boat is at an angle of depression of 10° . How far is the boat from the base of the cliff?
7. A 24 foot ladder is placed against a wall at 55° with the ground. How far away from the wall is the base of the ladder?
8. A 32 in. bat is leaning against a fence. If the bat is 15 in. away from the base of the fence, what angle is formed between the ground and the bat?
9. Ana knows that she is one mile from the base of a tower. Using a protractor she estimates an angle of elevation to be 3° . How tall is the tower to the nearest foot? (1 mile = 5280 feet)
10. A plane takes off at an elevation of 20° . In its path is the tower of 170 feet. If the plane at takeoff is 500 feet away from the tower. What is the altitude of plane? Will it clear the height of the tower? If yes, by how much?

Trig Worksheet 3

1. Which expression can be used to find $m\angle A$?

- (A) $\tan^{-1}(0.75)$ (C) $\cos^{-1}(0.8)$
 (B) $\sin^{-1}\left(\frac{3}{5}\right)$ (D) $\tan^{-1}\left(\frac{4}{3}\right)$

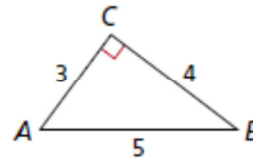

2. Which expression is NOT equivalent to $\cos 60^\circ$?

- (F) $\frac{1}{2}$ (H) $\frac{\sin 60^\circ}{\tan 60^\circ}$
 (G) $\sin 30^\circ$ (J) $\cos^{-1}\left(\frac{1}{2}\right)$

3. In the figure below, if $\sin x = \frac{5}{13}$, what are $\cos x$ and $\tan x$?

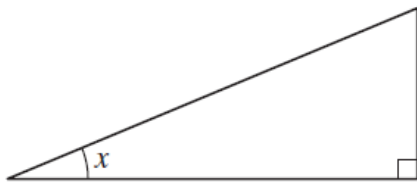

- A $\cos x = \frac{12}{13}$ and $\tan x = \frac{5}{12}$
 B $\cos x = \frac{12}{13}$ and $\tan x = \frac{12}{5}$
 C $\cos x = \frac{13}{12}$ and $\tan x = \frac{5}{12}$
 D $\cos x = \frac{13}{12}$ and $\tan x = \frac{13}{5}$

4. In the figure below, $\sin A = 0.7$.

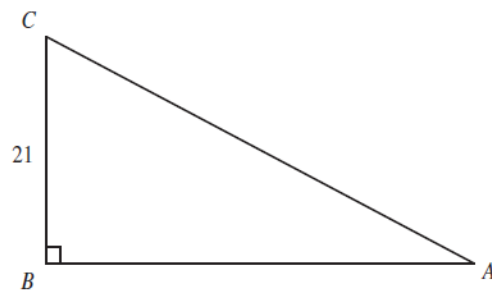

What is the length of \overline{AC} ?

- A 14.7
 B 21.7
 C 30
 D 32

6. Right triangle ABC is pictured below.

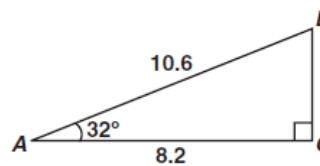

Which equation gives the correct value for BC ?

- A $\sin 32^\circ = \frac{BC}{8.2}$
 B $\cos 32^\circ = \frac{BC}{10.6}$
 C $\tan 58^\circ = \frac{8.2}{BC}$
 D $\sin 58^\circ = \frac{BC}{10.6}$

5. Approximately how many feet tall is the streetlight?

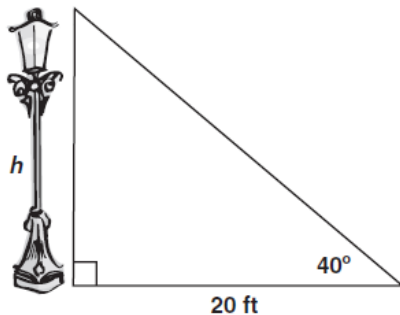

7. A surveyor 50 meters from the base of a cliff measures the angle of elevation to the top of the cliff as 72° . What is the height of the cliff? Round to the nearest meter.

8. **Grand Canyon Problem:** From a point on the North Rim of the Grand Canyon, a surveyor measures an angle of depression of 1° to a point on the South Rim. From an aerial photograph, he determines that the horizontal distance between the two points is 10 miles. How many **feet** is the South Rim below the North Rim to the nearest foot? (Note: 1 mile = 5280 feet)

9. At a point 125 feet from the base of a building, the angle of elevation to the third floor is 22° and to the 10th floor is 53° . How much higher is the tenth floor than the third floor?

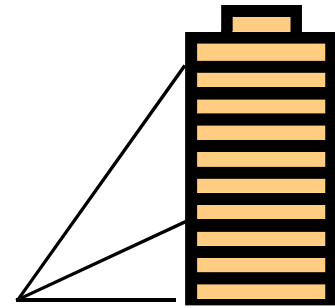

Use the triangle below for questions 1 and 2.

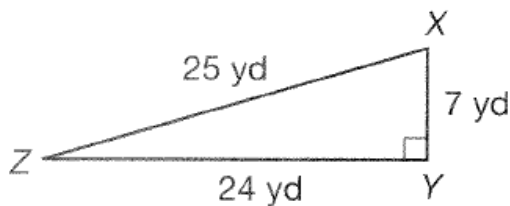

1. Which ratio is equivalent to $\sin Z$?

- A. $\frac{7}{24}$
- B. $\frac{7}{25}$
- C. $\frac{24}{25}$
- D. $\frac{25}{7}$

2. Which ratio is equivalent to $\tan X$?

- A. $\frac{7}{24}$
- B. $\frac{7}{25}$
- C. $\frac{24}{25}$
- D. $\frac{24}{7}$

12. What is the length of the altitude \overline{FH} of equilateral triangle EFG at the right? (HINT: Find the measures of the angles first.)

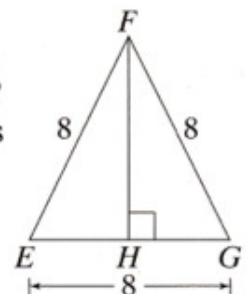

13. If $RSTW$ is a rhombus, what is the area of $\triangle WXT$?

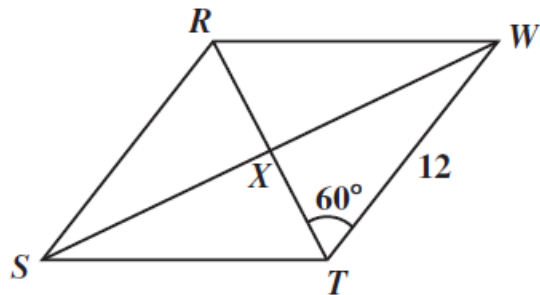

- A $18\sqrt{3}$
- B $36\sqrt{3}$
- C 36
- D 48

$\triangle FGH \sim \triangle KLM$. Use these triangles for questions 4–6.

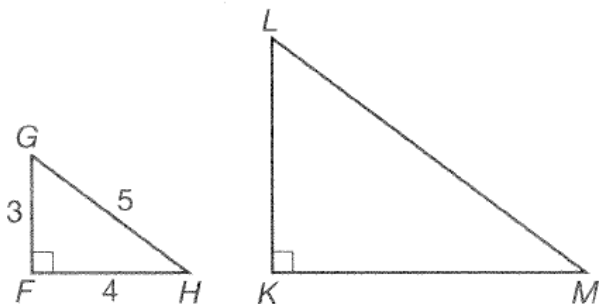

4. Which of the following must be true?
- A. $\tan G = \tan L$
 - B. $\tan G = \tan M$
 - C. $\sin H = \tan L$
 - D. $\sin H = \tan M$

14. In rectangle $JKLM$ below, what is the length of diagonal \overline{KM} ?

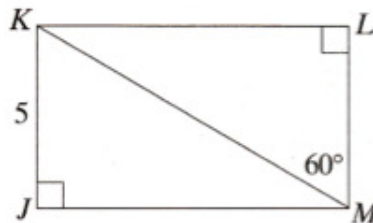

5. If $\sin G = \frac{4}{5}$, then which of the following must also be true?
- A. $\sin H = \frac{4}{5}$
 - B. $\sin K = \frac{4}{5}$
 - C. $\sin M = \frac{4}{5}$
 - D. $\sin L = \frac{4}{5}$
6. If $\sin H = \frac{3}{5}$, then which of the following must also be true?
- A. $\sin K = \frac{3}{5}$
 - B. $\sin L = \frac{3}{5}$
 - C. $\cos L = \frac{3}{5}$
 - D. $\cos M = \frac{3}{5}$

Review Assignment

1.

The size listed for a television screen represents the length of its diagonal, shown by the dashed line in the diagram below.



If Jeff wants a television screen with a width of 32 inches and a height of 24 inches, which listed size should he buy?

- A 46-in.
- B 40-in.
- C 56-in.
- D 32-in.

3.

Christopher has a garden in the shape of a square with a side length of 24 feet. He plans to plant tomatoes along the diagonal. How long is the diagonal of Christopher's garden?

- A 48 ft
- B 24 ft
- C $24\sqrt{2}$ ft
- D $24\sqrt{3}$ ft

5.

The ski slope known as Devil's Hill has an elevation from the ground of 45° . If the distance down the slope is 1500 meters, what is the altitude of the hill?

Answer: _____

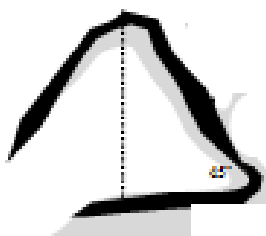

2.

Fernando's house is 5 miles directly west of his school and 12 miles directly north of his friend Brittany's house, as shown in the diagram below.

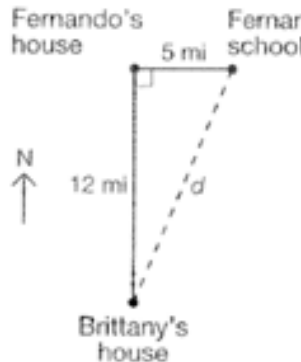

What is the direct distance, d , in miles, from Fernando's school to Brittany's house?

Record your answer and fill in the bubbles below.

<input type="radio"/>	<input type="radio"/>	<input type="radio"/>	<input type="radio"/>	<input type="radio"/>	<input type="radio"/>	<input type="radio"/>	<input type="radio"/>	<input type="radio"/>	<input type="radio"/>
<input type="radio"/>	<input type="radio"/>	<input type="radio"/>	<input type="radio"/>	<input type="radio"/>	<input type="radio"/>	<input type="radio"/>	<input type="radio"/>	<input type="radio"/>	<input type="radio"/>
<input type="radio"/>	<input type="radio"/>	<input type="radio"/>	<input type="radio"/>	<input type="radio"/>	<input type="radio"/>	<input type="radio"/>	<input type="radio"/>	<input type="radio"/>	<input type="radio"/>
<input type="radio"/>	<input type="radio"/>	<input type="radio"/>	<input type="radio"/>	<input type="radio"/>	<input type="radio"/>	<input type="radio"/>	<input type="radio"/>	<input type="radio"/>	<input type="radio"/>
<input type="radio"/>	<input type="radio"/>	<input type="radio"/>	<input type="radio"/>	<input type="radio"/>	<input type="radio"/>	<input type="radio"/>	<input type="radio"/>	<input type="radio"/>	<input type="radio"/>
<input type="radio"/>	<input type="radio"/>	<input type="radio"/>	<input type="radio"/>	<input type="radio"/>	<input type="radio"/>	<input type="radio"/>	<input type="radio"/>	<input type="radio"/>	<input type="radio"/>
<input type="radio"/>	<input type="radio"/>	<input type="radio"/>	<input type="radio"/>	<input type="radio"/>	<input type="radio"/>	<input type="radio"/>	<input type="radio"/>	<input type="radio"/>	<input type="radio"/>
<input type="radio"/>	<input type="radio"/>	<input type="radio"/>	<input type="radio"/>	<input type="radio"/>	<input type="radio"/>	<input type="radio"/>	<input type="radio"/>	<input type="radio"/>	<input type="radio"/>
<input type="radio"/>	<input type="radio"/>	<input type="radio"/>	<input type="radio"/>	<input type="radio"/>	<input type="radio"/>	<input type="radio"/>	<input type="radio"/>	<input type="radio"/>	<input type="radio"/>

4.

A farmer has a field that is in the shape of a parallelogram composed of a rectangle and two congruent $30^\circ-60^\circ-90^\circ$ triangles, as represented in the diagram below.

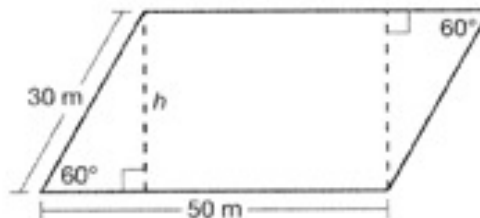

The area of a parallelogram is the product of the length of its base and its height, h . Which of the following measurements best represents the area of the farmer's field?

- A $(50 \cdot 5\sqrt{3}) \text{ m}^2$
- B $(50 \cdot 30\sqrt{3}) \text{ m}^2$
- C $(50 \cdot 15\sqrt{3}) \text{ m}^2$
- D $(50 \cdot 10\sqrt{3}) \text{ m}^2$

6.
a)

Find the diagonal length

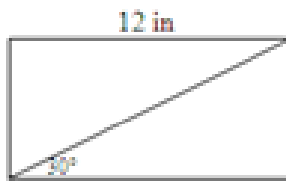

b)

Square: Find the side
If the diagonal is $5\sqrt{10}$

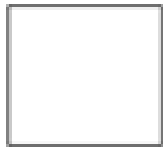

10.

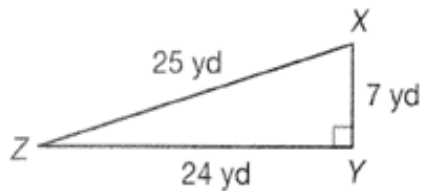

Which ratio is equivalent to $\sin Z$?

- A. $\frac{7}{24}$
- B. $\frac{7}{25}$
- C. $\frac{24}{25}$
- D. $\frac{25}{7}$

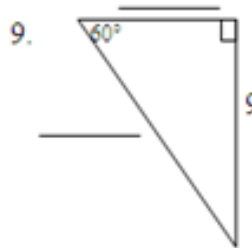
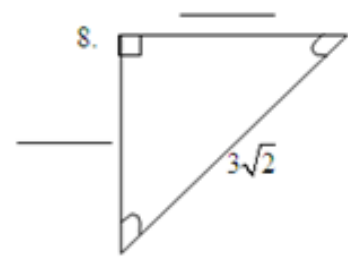
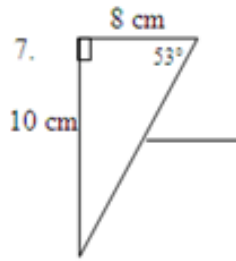

11.

Which ratio is equivalent to $\tan X$?

- A. $\frac{7}{24}$
- B. $\frac{7}{25}$
- C. $\frac{24}{25}$
- D. $\frac{24}{7}$

12.

Triangle XYZ is shown below.

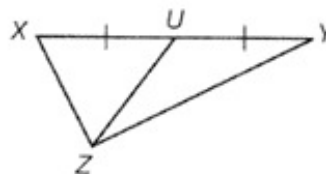

Which of the following describes \overline{UZ} ?

- A. an altitude of $\triangle XYZ$
- B. the angle bisector of $\angle XZY$
- C. the perpendicular bisector of \overline{XY}
- D. a median of $\triangle XYZ$

Use figure below for 13 and 14.

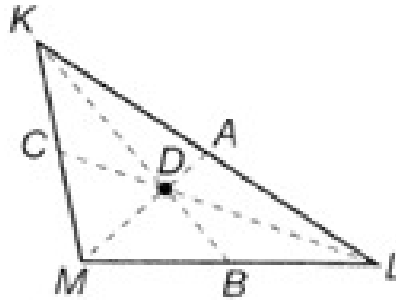

13. If $KC = 22$ units, what is the length of \overline{CM} ?

- A. 11 units
- B. 20 units
- C. 22 units
- D. 44 units

14. If $MD = 20$ units, what is the length of \overline{DA} ?

- A. 40 units
- B. 30 units
- C. 20 units
- D. 10 units

15. For which of the following statements is the contrapositive true?

- A. If a polyhedron has 5 faces, then it is a pyramid.
- B. If a quadrilateral has 4 right angles, then it is a square.
- C. If a line segment has both of its endpoints on a circle, then it is a diameter of the circle.
- D. If a triangle has a right angle, then it is a right triangle.