

UNIT-I VEHICLE STRUCTURE AND ENGINES

1.1 INTRODUCTION

The Petrol or Diesel engine is the source of power for Automobiles. Such engines are Internal Combustion or Heat Engines, the function of which is to convert heat energy available in the fuel into mechanical work.

An automobile is a self propelled vehicle. In other words, an automobile is one which can move by itself. As the name implies, it is a mobile or a moving power unit on road. Self-propelled means a unit which contains its own power source, necessary for moving, within itself. As a vehicle, it is used for transportation of passengers and goods.

Thus, an automobile is a self propelled vehicle which contains the power source for its propulsion and it is used for carrying passengers and goods on the ground. Bus, Car, Truck, Motorcycle, Scooter, etc., are good examples for self propelled vehicles.

1.2. VEHICLE CLASSIFICATION

1.2.1 The automobiles can be classified according to the following

1. Number of wheels and number of axles.
2. Type of power plants (prime movers) used.

3. Load carrying capacity and their weights.
4. Purpose served.
5. Fuel used.
6. Drive system used.
7. Capacity of the engine.

(1) On the basis of the number of wheels

1. Two-wheelers such as Mopeds, Scooties, Scooters, and Motorcycles.
2. Three-wheelers such as tempos, road rollers, tractors.
3. Four-wheelers such as Cars, jeeps, minibuses, trucks, tractors, buses and rā cars.
4. Five-wheelers such as road rollers.
5. Six-wheelers such as truck-tankers, good carriage vehicles.
6. Eight or more-wheelers such as a Car transporting vehicles, rocket transpor

(2) On the basis of the prime mover used

1. Steam engine driven auto vehicles.
2. I. C engine driven auto vehicles.
 - a) Petrol vehicles
 - b) Diesel vehicles
 - c) Gas vehicles
3. Gas turbine driven auto vehicles.
4. Wankel engine driven auto vehicles.
5. Electric power driven auto vehicles.
6. Battery (Chemical power) driven auto vehicles.
7. Solar energy driven auto vehicles.
8. Hybrid powered auto vehicles.

(3) On the basis of the weight of the vehicle and its payload capacity

1. Light weight or light duty vehicles.
2. Medium weight or medium duty vehicles.
3. Heavy weight or heavy duty vehicles.
4. Extra heavy duty vehicles.
5. Special purpose (load) vehicles.

(4) On the basis of the purpose served

1. On-the-road vehicles - Scooters, Cars, trucks, etc.,
2. Off-the-road vehicles - Tractors, Construction equipment, etc.
3. On and Off-the-road vehicles- Military tanks, Gun carriage, etc.

(5) On the basis of the fuel used

1. Petrol vehicles such as Maruti Omni, Matiz, Felicia, Santro,
2. Diesel vehicles such as Mercedes-Benz E250D, Ambassador Diesel.
3. Dual Fuel (Petrol and Diesel) vehicles such as Fargo, Dodge
4. Gas vehicles such as CNG (Compressed Natural Gas) Volvo
5. Hydrogen vehicles such as Musashi III Car.

(6) On the basis of type of the wheel drive system

1. Single Wheel drive (1 Wd)
2. Two Wheel drive (2 Wd)
3. Four Wheel drive (4 Wd)
4. All Wheel drive (6 Wd or more)

Left hand drive and Right hand drive vehicles

Whether a vehicle is front wheel drive or rear wheel drive; has 2 wd or 4 wd; it is controlled by the driver through a steering wheel. The steering wheel may be located either on the left or on the right side of a vehicle. Depending upon its position, the autovehicle is known as left hand drive vehicle or right hand drive vehicle.

(7) On the basis of the engine capacity

The Capacity of an engine is expressed by its swept volume which is given as

$$V_s = \pi D^2 L / 4$$

Table : Engine capacity of some autovehicles

ENGINE CAPACITY (CC)	VEHICLE
47.5 (50)	Escort 'Toro Jazz', 'Roza'
60	Kinetic Safari V2, Bajaj Signets
70	TVS Sport
75	Hero Winner, Pearl Yamaha, LML Zip
93	Kinetic K-4
150	Bajaj, Lambretta
796	Maruti Omni
1200	Premier Padmini
1366	Premier Diesel
1489	HM Trekker
2982	Toyota Land Cruiser

1.3 VEHICLE CONSTRUCTION

The Automobile consists of two main assemblies

1. Chassis
2. Body (Superstructure)

The Chassis is a combination of various components which enable the vehicle to run on the road. A body mounted on the chassis is a box or lid to cover the vehicle. In general construction, the Chassis comprises of the following main details.

- Basic structure
- Transmission Unit
- Electrical Systems
- Body (or Superstructure)
- Power Unit
- Accessories Unit
- Control and Instruments

1.4 CHASSIS

An Automobile is made up of mainly two units - The body and the Chassis.

A vehicle arrangement without body is called chassis. The various components and systems of the chassis are the power unit, power train and the running systems.

The power unit contains only the engine; transmission includes clutch, propeller shaft with universal joints, differential and the rear axle shafts; Running systems consist of brakes, wheels, tyres, frame, suspension and the steering system.

The layout of a conventional chassis with various components mounted on it is shown in figure 1.1.

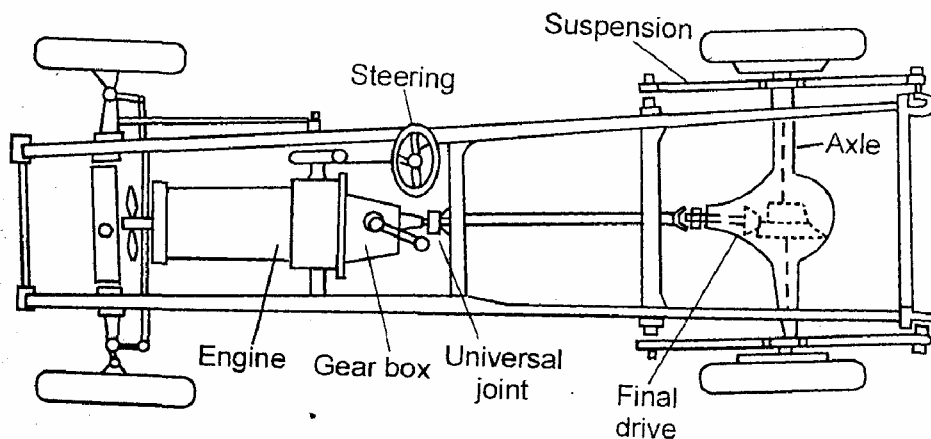

Figure 1.1 Chassis layout

Cross bracings are provided in the chassis to withstand the shock, blows, twists and vibrations. As per the layout, the engine is mounted on the front part of the frame. Rubber cushioned mounts or pads are used to support the engine on the frame. The clutch is placed, next to the engine, connected to the flywheel; Transmission or the gear box is positioned or attached to the clutch shaft. Then a propeller shaft is laid to connect the gear box on one end and the final drive on the other end. These are enclosed in a housing, bolted to the rear axle spring, which is connected to the frame through springs. The entire arrangement mounted and bolted on the chassis frame is supported by the front and rear suspension systems. This is positioned over front and rear wheel and tyre assemblies, to avoid or minimise the transmission of shock to the frame.

The Chassis includes the following components

- | | |
|---|--------------------------------|
| 1. Frame | 2. Front suspension |
| 3. Steering mechanism | 4. Radiator |
| 5. Engine, Clutch, Gear box | 6. Propeller Shaft |
| 7. Rear springs | 8. Road wheels |
| 9. Differential, half shaft, Universal joints | 10. Brakes and Braking system, |
| 11. Storage battery | 12. Silencer |
| 13. Shock absorbers, fuel tank, Petrol and hydraulic pipe cables and some means of mounting these components. | |

1.5 FRAME

The word frame is used to denote the main skeleton of the vehicle. In automobile construction, chassis frame forms the basic requirement. It serves as the main foundation and base for alignment for the chassis. The front end of the frame carries the engine and the rear end carries rear axle housing, the wheels and tyres. The other components on the frame are steering system, fuel tank, battery, brake, shock absorber etc.

The frame is provided with cross rods to increase the rigidity, withstand shocks and vibration.

by a frame, which is supported on the wheel axis by the leafsprings. Normally used cross sections are channel section, Tubular or Box section. Channel section is good for bending; Tubular section resists torsion and Box section serves as good resistance to bending and torsion. The construction of chassis must maintain the working assemblies in their correct positions and also provide easy mounting of the body.

The frame is closer at the front to provide adequate steering lock and unswept at the rear to provide clear space for the movement of the axle. Due to springing action it also makes the chassis height low.

2. Integral or frameless type

The body structure is fabricated to carry out the functions of the body and frame. The units that are attached to the body are also riveted directly to the frame. Frame-less construction has the advantage of reduced weight, less manufacturing cost, absorbing shock during accident.

Back bone frame

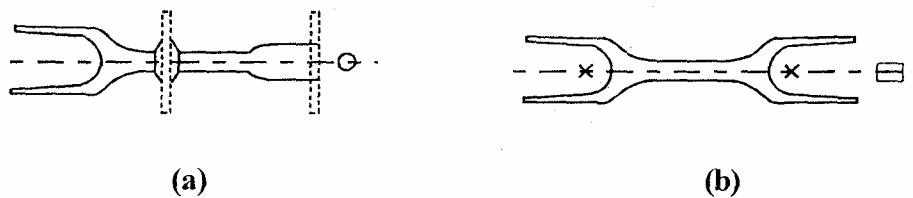

Figure 1.2 Back bone frame

A central longitudinal steel tube is called back bone. The Cross Section of the frame is shown in the figure 1.2. The section shown in (a) uses single arm parallel type of suspension. The engine gear box unit is accommodated at the forked front end of the frame and the driving shaft is made to pass through the inside of the central tubular portion of the frame. The dotted line indicates some brackets used to support the body. The frame shown in (b) is slightly different. In that, the cross section is built up of two channel sections, which are pressed and welded together. This type of frame has been used in independent suspension.

Frame members

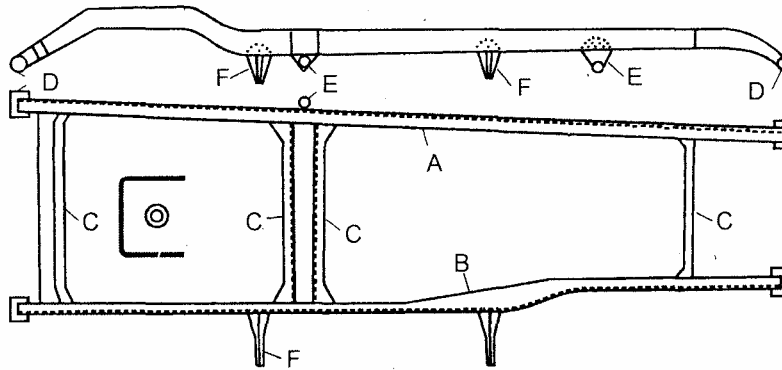

Figure 1.3 Chassis frame - conventional

The construction of the frame is shown in figure 1.3. This consists of longitudinal or side members A and B, generally made in the form of pressing channel section. These are generally arranged to be closer at the front. The members are brazed by a number of cross members - C.

Dump irons - D are provided at the front and rear ends. Brackets 'E' are as shown, to which springs are connected and brackets are provided to support the rubbers. Some more brackets F supporting the engine, gear box, brakes, shafts etc are provided at the required places. The frames are stiffened with cross pressing for independent suspension and are stiffer at the front end.

X - type frame

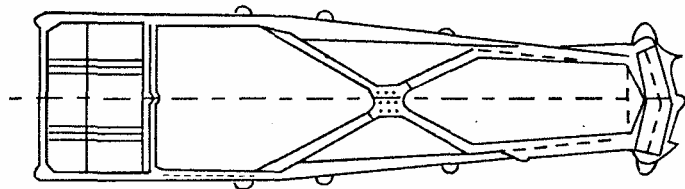

Figure 1.4 X-type frame

Some of the chassis frames are cross members which cross in the form of an X as shown in figure 1.4. The side members and cross members are rigidly attached to each other by riveting or welding. Heavy side members are eliminated and cross members are connected with the floor of the body. 'X' member may be of channel or box section. This imparts torsional rigidity to the frame.

Integral or frameless or chassis less type

This is sometimes known as unitary monocoque or integral construction. This arrangement provides stiff and light construction and heavy side members eliminated. The floor is strengthened by cross members. In this type of arrangement there is no separate frame, all the components are attached to the body. In this arrangement, assembly procedure is quick and easier. Moreover, the body is light and strong.

The structure contains an under frame with side members and cross members which are welded together as a single assembly. The pressed steel body is attached to the under frame by welding and riveting. A sub-frame can be attached to the body frame in the front of the body shell, to carry the engine on the front suspension. Grooves are pressed in the steel floor and side pannels to provide increased stiffness to the floor. This construction is shown in the figure 1.5. Throughout the structure, the stresses are evenly distributed. Good torsional rigidity and resistance to bending are provided by this welded structure and reinforcement with thicker material is provided at some points where certain components are to be attached. In certain cases, rubber insulations are used in the sub frame to mount the engine and suspension members.

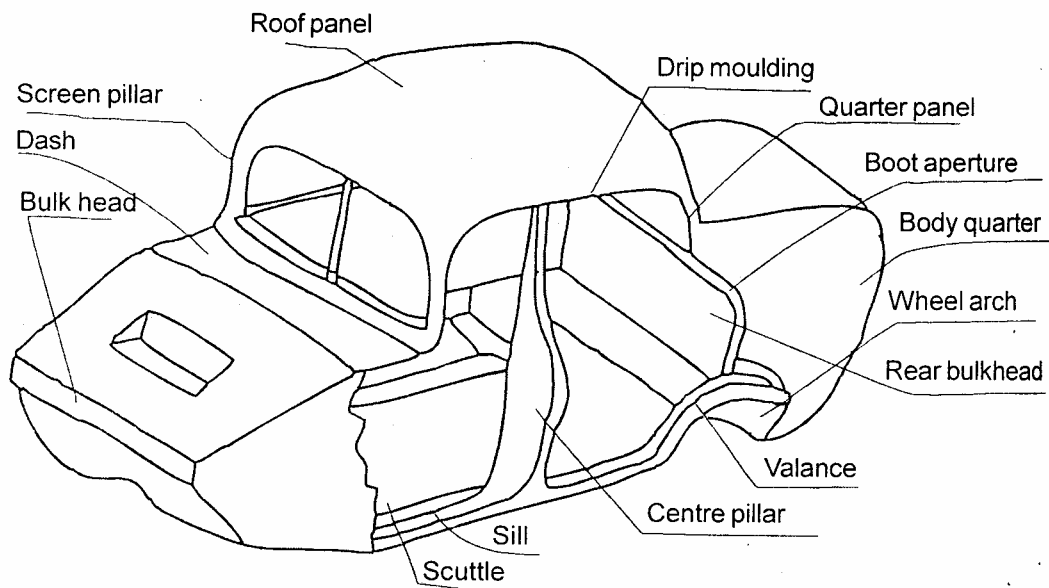

Figure 1.5 Car body

Sub-Frame

Mostly different components of the motor vehicle are bolted directly either on the main frame or on the cross members of the frame. But the engine and the gear box are sometimes supported on additional frames called Sub-frames. These are simple in construction, and mounted on rubber blocks. The Sub-frame supports the main frame at three points. This is to isolate the components from twisting and flexing effects, and thereby to protect the body from engine vibrations. Sub-frames are used in vehicles, employing independent rear suspension.

Some of the advantages of sub-frames are

1. Helps to dampen vibrations.
2. Simplifies production while assembling and facilitates repair, service and overhaul.

1.6 BODY

Body is the superstructure of the vehicle. This is bolted to the chassis. A complete vehicle is referred to the combination of Chassis and Body. Body is merely a cover to the Chassis. The body may be shaped according to the needs and convenience. The body of the motor vehicle must fulfill the following requirements.

1. Sufficient space to accommodate passengers and luggage.
2. Suitable shape to reduce air resistance
3. It should be light and strong enough to resist bending, torsion and impact stresses.
4. It should have continuous access to the engine and suspension system.
5. The load should be distributed evenly.
6. The mounting of the body should have minimum vibrations.
7. It should be cheap and simple in manufacture.
8. The design of the panels should be suitable for mass production and changes in style and design.
9. It should be made of sheet metal of sufficient thickness for adequate safety during collision.
10. It should provide clear vision and be of aesthetic in shape.

ENGINE TYPES

Internal combustion engines can be classified on any one of the following :

a) Type of fuel used:

1. Petrol or Gasoline engine
2. Diesel engine
3. Gas engine

b) Cycle of Operation:

1. Otto cycle engine
2. Diesel cycle engine
3. Dual combustion cycle or semi-diesel engine

c) Type of Ignition used:

1. Spark ignition engine
2. Hot-spot ignition engine
3. Compression ignition engine

d) Method of fuel admission:

1. Carburettor engine (Petrol)
2. Air injection engine (Diesel)
3. Airless or solid injection engine (Diesel)

e) Number of strokes per cycle:

1. Four stroke engine
2. Two stroke engine

f) Arrangement of cylinders:

1. Vertical engine
2. Horizontal engine
3. Radial engine
4. V-engine
5. Opposed cylinder engine

g) Valve location:

1. Overhead valve engine
2. Side valve engine

h) Type of cooling engine:

1. Air cooled engine
2. Water cooled engine.

i) Lubrication Systems:

1. Wet sump
2. Dry sump
3. Pressurised

j) Speed:

1. Slow speed engine
2. High speed engine
3. Medium speed engine

k) Method of Governing:

1. Hit and miss governed engine
2. Qualitatively governed engine
3. Quantitatively governed engine

l) Application:

1. Stationary engine
2. Automotive engine
3. Marine engine
4. Locomotive engine

One of the classifications of Internal combustion engines is by cylinder arrangement, Normally there are four methods by which engine cylinders may be arranged. 1. Inline 2. Vee Type 3. Opposed Cylinders 4. Radial.

1. Inline

As shown in figure 1.7 the cylinders are arranged side by side in one row. The cylinder nearest to the radiator is called cylinder number 1.

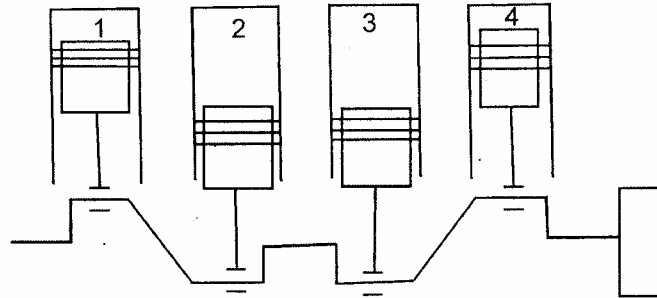

Figure 1.7 In-line

2. Vee type

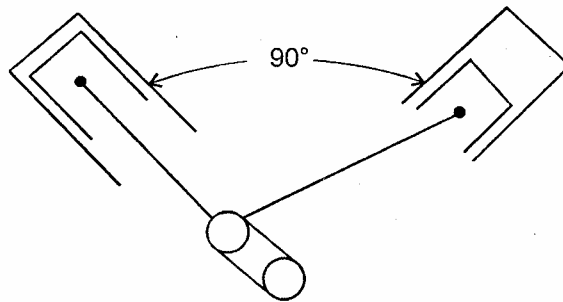

Figure 1.8 Vee type

This type is very compact in construction and has a common crankcase. In this arrangement, the axes of the cylinders are inclined to one another usually at 60° . While comparing with the Inline Engine, Vee Type engines are shorter. The short crank shaft is of good rigidity and operated smoothly with high engine speed. A Vee-Six engine has two rows of three cylinders arranged with radial angle of 60° .

3. Opposed cylinders

This method is suitable for installation at the rear of the Automobile. As shown in figure 1.9, the cylinders are arranged in opposite direction with the common crank shaft and with pins at 180° apart. This arrangement may have cylinders with horizontal

or vertical axis. In the case of opposed pistons type, a single cylinder houses two pistons with a separate crank shaft. Since the connecting rod movements are identical, it provides a good mechanical balance, but as the crank pins are not in the same line, they produce a rocking couple. This couple produced in either of the directions may tend to swivel the engine horizontally. More over the main disadvantage of this engine is its longer length and has to be placed in transverse direction. The vehicle is normally aircooled.

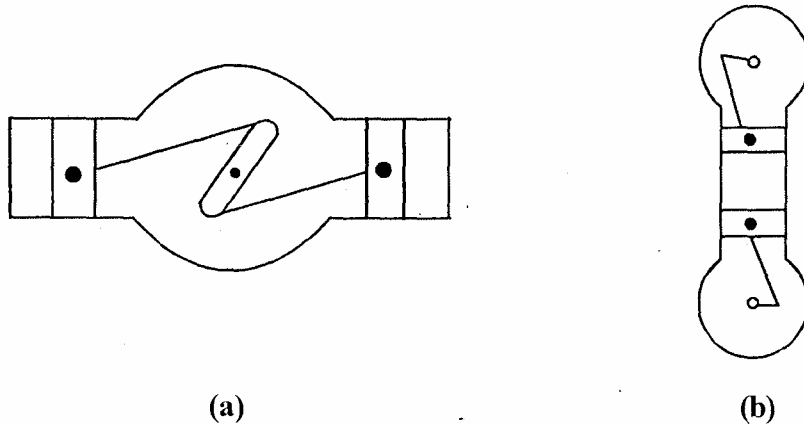

Figure 1.9 Opposed cylinders

4. Radial engines

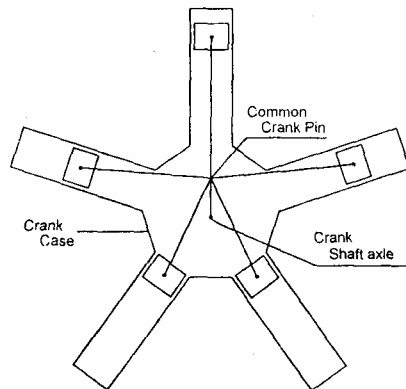

Figure 1.10 Radial engines

This arrangement is shown in figure 1.10 which consists of a single common crank shaft in odd number of cylinders. A single crank pin is employed for all the connecting rods. Because of the Odd number of cylinders, uniform firing is obtained advantageously. Five cylinders are generally used for automobile purposes and seven or nine for Air Craft. They are simple, compact and provide high horse power. These engines are of air cooled type. But they create difficulty in stream line design of the vehicle.

Classification by valve arrangement

Automobile engines are classified mainly into four categories with respect to the arrangement of valves. This arrangement is known as L.I.F and T types. The construction of the cylinder with respect to valves is shown in figure 1.11.

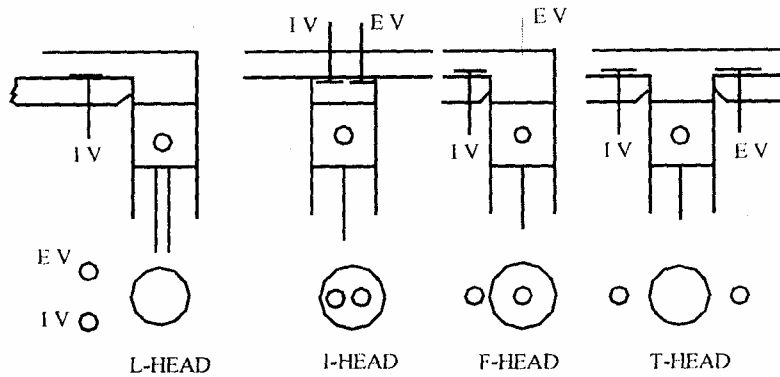

Figure 1.11 Classification - Valve arrangement

'L' Head Engine

In this arrangement, both valves are located by the side and operated by a single camshaft. The Combustion Chamber and Cylinder form an inverted 'L'.

'I' Head Engine

This arrangement is usually called 'over head valve engine'. In this case the valves are located in the cylinder head. The valves are normally arranged in a single row. A single camshaft operates both the valves.

'F' Head Engine

This is a combination of L and I engines. Inlet valve is in the head and exhaust valve in the cylinder, both valves are operated by the same camshaft.

'T' Head Engine

In this case, the arrangement of the valve and cylinder resembles letter 'T'. Valves are placed on either side of the cylinder. Separate cam shafts are required to operate them.

1.7.1 Special types of automobile engines

1. Square Engine
2. Wankel Engine
3. Automotive Gas turbine
4. Electric car
5. Hybrid car.

Square Engine

In this type of engine, the length of stroke is equal to the cylinder diameter. In the normal engines the Stroke/ Bore ratio is more than one. In square engines the piston speeds are lower than that of the corresponding engines of large strokes. The square engines develop more power with lesser fuel consumption than the larger stroke engines.

1.7.2 Wankel engine

This engine works on Otto-cycle. But this have a rotary piston of triangular shape. This has been developed on the basis of the design of FELIX WANKEL of N.S.U, Germany for commercial purposes. The figure 1.12 shows a simplified construction of Wankel Engine.

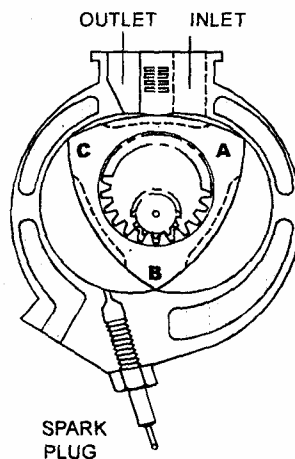

Figure 1.12

This consists of a Epi-trochoidal housing. A three lobe rotor rotates in this housing. The design and construction is in such a way that the tips of the rotor always remain in contact with the casing so as to maintain three different chambers. Inlet and outlet ports are provided as shown in the figure. The housing is surrounded by water- cooling system. The rotor is having internal teeth and rotates in meshing with the pinion in an epi-cyclic manner.

Operation

The sequence of operation are similar to that of the reciprocating I.C engine. It take place in three different chambers which is continuously varying by the rotation of the lobe. The various positions are shown in the figure 1.13.

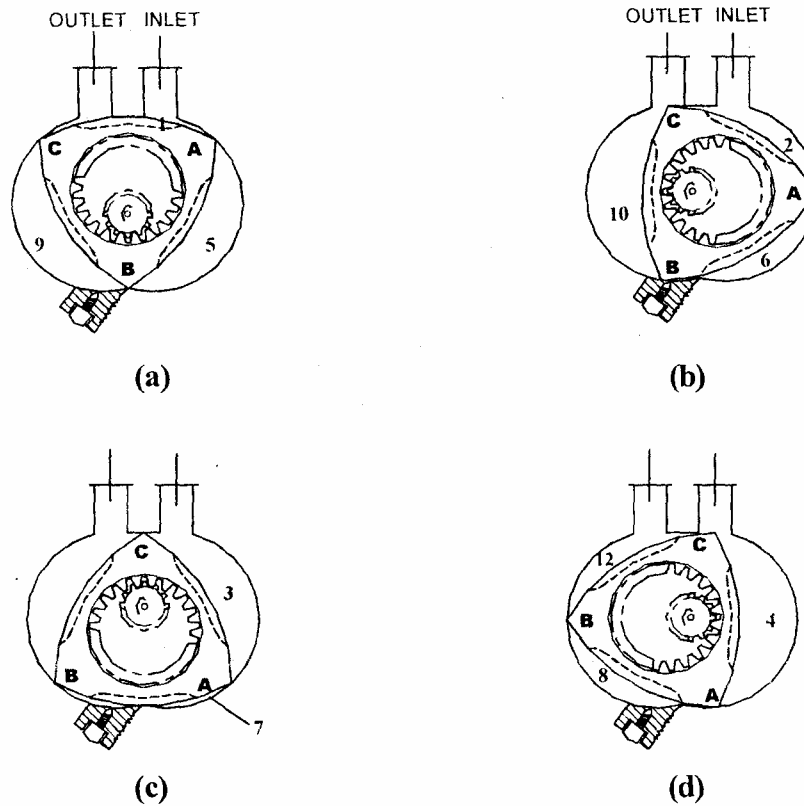

Figure 1.13

In figure 1.13(a) Induction process takes place which is supposed to be complete in Stage - 4 as in figure 1.13(d) Now, let us consider the side AB in figure 1.13(a); the compression process starts and it gets completed through the Stages 5, 6 and 7.

Now, when the side AB forms the chamber as in figure 1.13(d) a spark plug ignites and start the expansion process which proceeds, through the stages 9 and 10 as shown in figure 1.13 (a) and (b). Now consider the side BC again in figure 1.13 (c) and (d). In stages 11 and 12, the exhaust process is being followed. Thus the cycle gets repeated. So one cycle of operation is completed in one revolution of the rotor. It is to be noted that when a particular side of the lobe is followed for the sequence of operations,

the other two sides different sequence of operations are followed and similar process also takes place at the same time. Thus one full revolution completes three Otto-cycles. Therefore it leads to a compact size of the Wankel engine.

Advantages of wankel engine

1. For a given power output, Wankel engine is smaller in size and weight.
2. Volumetric efficiency is higher.
3. The balancing is easier as there are no reciprocating parts.
4. The construction is simpler with lesser number of working parts.
5. It can operate on low octane petrol with lesser NO_x emissions.
6. With advanced materials Wankel engine is cheaper than I.C. engines.
7. It is cheaper in construction for mass production.

Disadvantages

1. Lesser torque at lower speed.
2. High specific fuel consumption.
3. Possibility of chamber distortion.
4. Lower braking effect.
5. Because of ignition troubles spark plugs are to be changed frequently.
6. Higher speed range leads to critical design of transmission system.
7. Chamber sealing problem is a difficult one.
8. It emits exhaust at very high temperature.

1.8 ENGINE CONSTRUCTIONS

Construction of an automobile engine

The main components of an Automobile Engine are: -

Cylinder block, Cylinder head, Cylinder liner, Piston, Piston rings, Crank Shaft Cam Shaft, Timing gears, Side valves, Overhead, valves and over head cam shaf mechanism.

Cylinder

A cylinder in an Internal Combustion Engine is the main part in which combustion takes place. The cylinder has to withstand high temperatures and high pressures.

Cylinder block

This is the main block of the engine. This contains the cylinder and provides housing for the crank, crank shaft and other engine parts. This is the basic frame for the engine, the other parts are fitted on it.

This block contains

- 1) Smooth cylinders
- 2) Ports or openings for valves and
- 3) Passages for cooling water.

Cylinder head

This is the top most part of the engine which covers the cylinder. It is bolted with cylinder block at the top.

Sandwich Gaskets made of soft copper and asbestos sheet are used so that a gas tight joint is formed. These joints will withstand high pressure and heat developed in the combustion chambers. This is usually cast as a single piece as shown in figure 1.14.

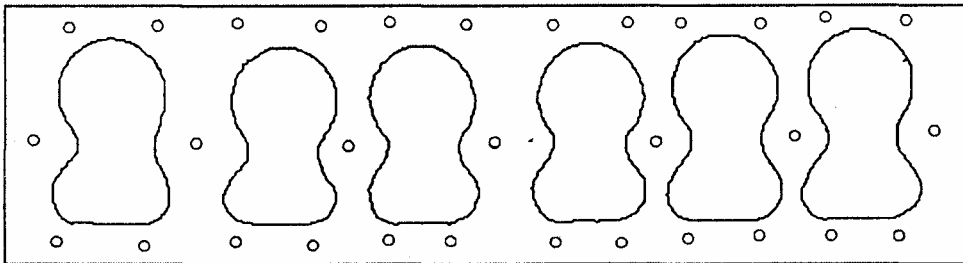

Figure 1.14 Gasket

The cylinder head provides cavities for valves, injectors or spark plugs, combustion chamber and bolt holes for the inlet and exhaust manifolds attached to it, with provision for flow of water.

Cylinder liner

The cylinder may wear out after frequent use. Hence the cylinders have to be replaced, but this is very costly. Therefore, instead of replacing the complete cylinder, it is better to fit a parallel sleeve in the block (just like a bush) This sleeve is known as cylinder liner (refer to the figures - 1.15).

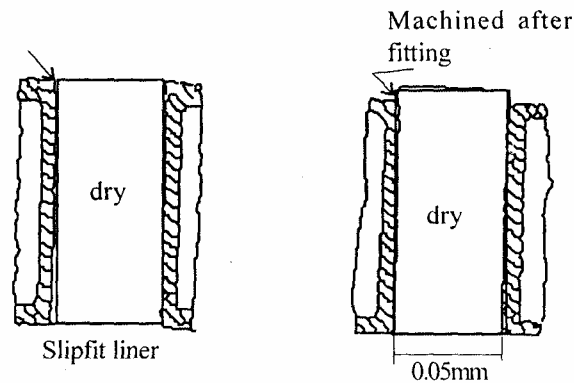

Figure 1.15 (a) Dry liner

These liners provide suitable wear resisting surfaces within the cylinders.

These are manufactured by centrifugal casting method.

Cylinder liners are of two types,

- 1) Dry liner.
- 2) Wet liner.

Dry liner

The dry liner is directly inserted into the cylinder block. Cooling water is not in contact with the dry liner. This type of liner is machined very accurately and pressed into the cylinder block. The outer surface of the liner rests against the cylinder block.

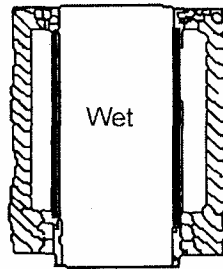

Figure 1.15 (b) Wet liner

Wet liner

In this case, cooling water is in direct contact with the outer surface of the liner. In this type, the liner is machined only on the inside and the outer surface is in contact with water. There is a flange at the top of the liner acting as a shoulder by which it is fixed in the groove made in the cylinder block. At the bottom, synthetic rubber sealing rings are provided around the liner to prevent water leakage.

These types of liners are generally used in diesel engines. If the size of the piston bore clearance exceeds the standard limit both the liner and piston are to be replaced simultaneously. In case the cylinder bore exceeds the maximum size limit, the standard size of piston is fitted with installation of a new liner. These are thicker than dry liners.

Piston

The piston is the main active part of the engine. It has a close fit with the cylinder. The movement of the piston changes the volume in the cylinder and provides the combustion space. Generally, the pistons are made up of aluminium alloy. The aluminium alloy is the lightest one and has good heat conduction properties. A hole is centrally provided to insert a pin to connect the small end of the connecting rod. Circumferential grooves are provided on the surface of the piston.

Functions

- 1) The piston receives the thrust produced by combustion and transmits the power to the connecting rod.
- 2) It reciprocates to cause different strokes.
- 3) It acts as bearing to the small end of the connecting rod and bears side thrust.

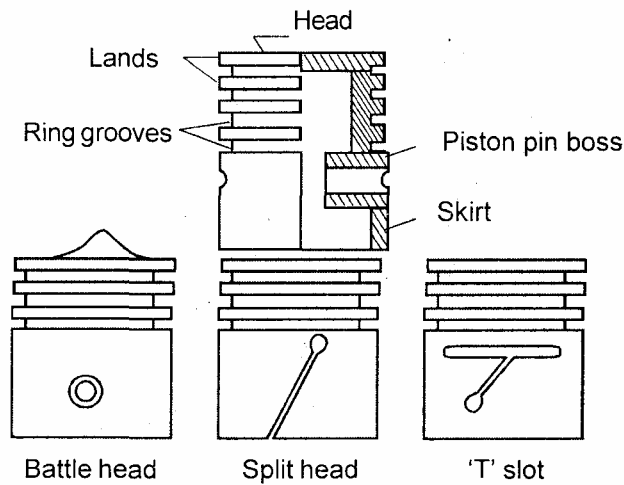

Figure 1.16 Piston

The piston diameter is slightly smaller than that of the cylinder. The gap between the piston and the cylinder wall is known as the piston clearance. This clearance is provided to avoid seizing of the piston in the cylinder. This clearance also provides the gap for a film of lubricant between the piston and the cylinder wall. A simple piston is shown in figure 1.16.

Piston rings

These are made of special steel alloys which retain elastic properties at high temperature. These are circular rings fitted in the circumferential grooves of the piston. There are two sets of rings. Upper rings are known as compression rings which provide gas tight seal. This will prevent the leakage of the burnt gases into the casing. The lower rings are called oil scraper rings. These are provided to remove the oil film from the engine cylinder and prevent the leakage of oil into the cylinder. Refer figure 1.17.

Functions of piston rings

1. Prevention of leakage of gas into the crank case.
2. Prevention of lubricating oil film
3. Prevention of lubricant entry into the combustion chamber above the piston head.
4. Removing unnecessary and excessive lubricating oil from cylinder wall.

5. Prevention of carbon deposits and other impurities on the piston head.
6. Easy transmission of heat from piston to cylinder wall
7. Balancing of side thrust of the piston.

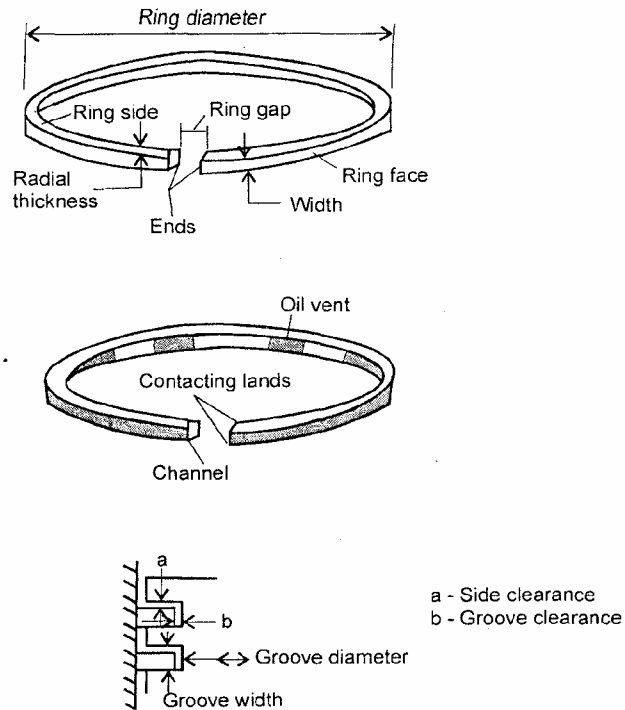

Figure 1.17 Piston ring

Connecting rod

This is the connecting link between the piston and the crank shaft, as shown in figure 1.18. By the oscillating movement of the connecting rod, reciprocating motion of the piston is converted into rotary motion of the crank shaft. The upper end of the connecting rod is called the small end, which carries the piston by means of a floating pin called piston pin or gudgeon pin as shown in figure 1.19. The lower end is called the big end of the connecting rod, which connects the crank shaft through a crank pin.

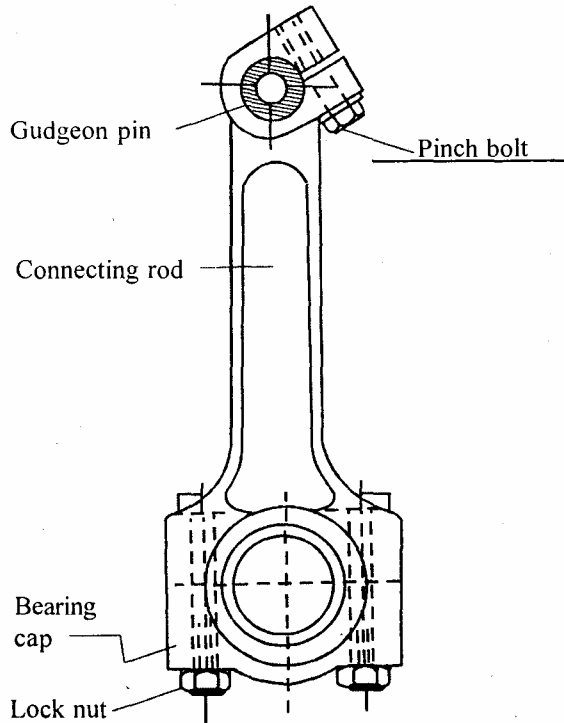

Figure 1.18 Connecting rod

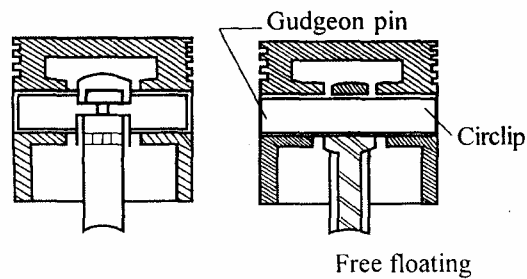

Figure 1.19 Gudgeon pin

Crank shaft

This is the main shaft in the engine as shown in figure 1.21. All the other working parts are directly or indirectly coupled to it. This converts reciprocating motion of the piston into rotary motion and then transmits to the clutch. The main parts of the crank shaft are crank pins, main journal, balance weight and flywheel flange. Oil holes are drilled for lubrication purpose as shown in figure 1.20. The crank shaft is made from a steel forging and machined.

1.9 ENGINE OPERATION

1.9.1 Working of four stroke petrol engines

The four stroke petrol engine works on the Otto cycle. It gives a power stroke in every set of four strokes of the piston or two revolutions of the crank shaft. The working substance in the petrol engine is petrol vapour and air.

The different strokes are explained as below:

1) Suction stroke - Figure 1.31 (a)

The position of the piston and other arrangements are as shown in figure 1.31(a). During this stroke the piston descends and the inlet valve starts opening. The exhaust valve remains closed. The movement of the piston sucks the mixture from the carburettor.

2) Compression stroke - Figure 1.31(b)

This is shown in figure 1.31 (b). During this stroke, the piston moves from the bottom dead centre to the top dead centre. The inlet and exhaust valves remain closed. The air fuel mixture sucked in during the suction stroke is compressed. The heat which is produced by compression helps in combustion. Before the compression stroke is completed the mixture is ignited by a spark produced by the spark plug. During this operation external work is being done by the piston. So it is termed as negative work.

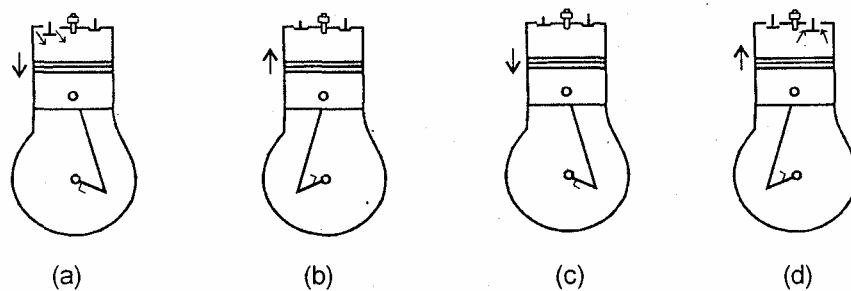

Figure 1.31 Four strokes of petrol engine

3) Working or power stroke - Figure 1.31 (c)

During this stroke, the piston moves from the top dead centre to the bottom dead centre. Both the inlet and exhaust valves still remain closed. Because of the combustion of the fuel air mixture, the burnt combustible mixture expands. This expansion forces the piston down. Under this impulse, the piston moves downwards doing useful work. During this power stroke, work is being done on the piston.

4) Exhaust stroke - Figure 1.31(d)

Due to the inertia achieved and the crank movement, the piston is made to travel upwards. During this stroke, the piston moves from the BDC to TDC. Before the start of the stroke, the exhaust valve starts opening. The products of combustion escape through the exhaust valve. As the piston reaches near TDC. (slightly before TDC), the inlet valve will open again for the start of the next cycle. The cycle of events takes place continuously, thus delivering work.

1.9.2 Working of four stroke diesel engines

The diesel engine, the ignition of the fuel takes place in the compressed air at high temperature and pressure. The temperature of the compressed air itself is sufficient to ignite the fine particles of fuel. The various strokes are explained as follows:

1) Suction stroke - Figure 1.32 (a)

Refer figure 1.32(a). The piston moves from the top dead centre to the bottom dead centre. The inlet valve starts opening before the piston is very near to the TDC. Exhaust valve remains closed. As the piston descends, because of the variation in pressure within the cylinder and that at atmosphere, air alone is sucked in through the inlet valve, which closes at the end of the stroke.

2) Compression stroke - Figure 1.32 (b)

During this stroke, the piston moves from BDC to TDC, both the valves remaining closed. The air drawn into the cylinder during the previous stroke is now compressed by the upward movement of the piston. Because of high compression ratio and high pressure, at the end of the compression stroke, the temperature within the cylinder is high enough to ignite the fuel injected.

Combustion

When both the valves remain closed, fuel is injected into the compressed air which is at a very high temperature and pressure. Ignition takes place within a homogenous mixture formed in the combustion chamber. The combustion reaction forces the piston downwards.

3) Power stroke - Figure 1.32(c)

The expansion of the gas forces the piston downwards. During this stroke, the piston moves from TDC to BDC. Both the valves remain closed. As the work is done on the piston, it is termed positive. This is the useful work required. The stroke is completed as the piston reaches BDC.

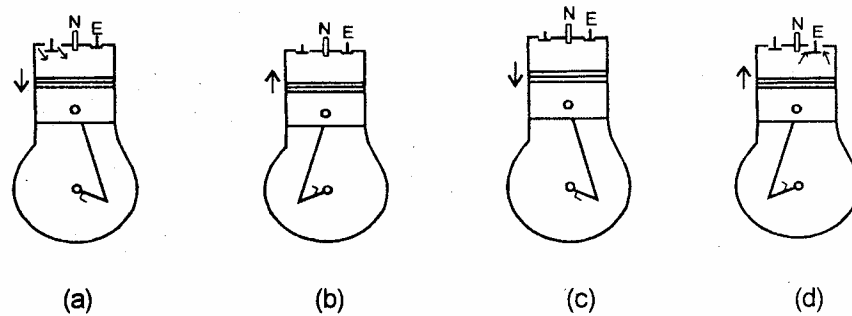

Figure 1.32 Four strokes of diesel engine

4) Exhaust stroke - Figure 1.32 (d)

Now the piston moves once again towards TDC. During the start of the stroke, the exhaust valve starts opening. The upward movement of the piston removes the remaining gases through the exhaust valve. The exhaust valve closes at the end of the exhaust stroke. Before the piston reaches TDC, very near to TDC, the inlet valve will start opening for the next cycle.

1.9.3 Two stroke engines

Two stroke engine performs only two strokes to complete the cycle. Suction stroke and exhaust stroke in a four stroke engine can be eliminated in this design. Rather they are combined with the working and the compression strokes. The principle of operation is the same as four stroke engine. There is one working stroke for every revolution of the crank shaft.

The construction is shown in figure 1.33 (a). It consists of a cylinder covered at the top and a hermitically sealed crank case at the bottom. Instead of valves, three ports are provided, on the walls of the cylinder. Exhaust port is placed slightly above the inlet port. Another port called transfer port is placed diametrically opposite, but slightly at a lower level to the exhaust port. Similar to the four stroke engine, crank shaft, connecting rod, piston, piston rings, piston pin are assembled as a link.

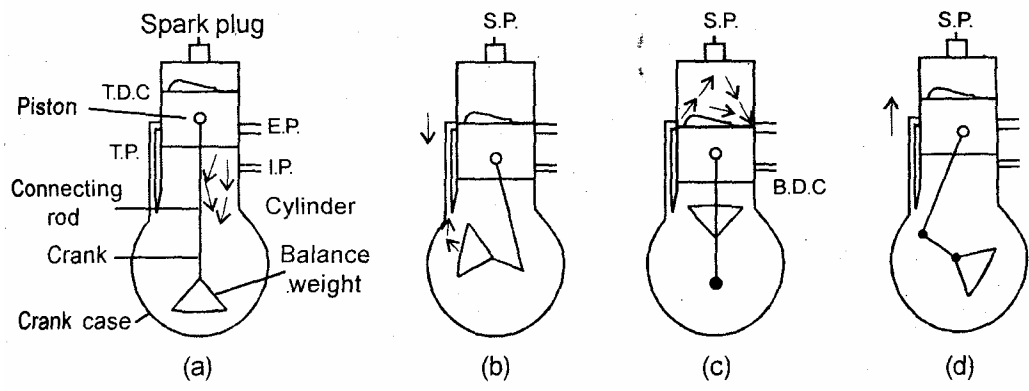

Figure 1.33 Two stroke petrol engine

The crown of the piston is deflected upwards to avoid mixing of fresh mixture with the exhaust gas and also to help to deflect the fresh mixture upwards (to drive the exhaust). These engines are air cooled by cooling fins arranged around the outer surface of the cylinder. Spark plug is screwed on the top of the cylinder head for petrol engine and a fuel injector in case of a diesel engine.

Working of two stroke petrol engine

First stroke

Two stroke petrol engine works on the principle of Otto cycle. The two stroke petrol engine consists of cylinder and piston arrangement, so that it can function as a pump in conjunction with the piston. At the beginning of the first stroke let us assume the piston is in the highest position at the end of the compression stroke. When the piston is at the top dead centre as in figure 1.33(a), the transfer port and exhaust port are covered by the bottom portion of the piston. This allows the fresh mixture of petrol and air to enter beneath the piston. When the piston descends, it compresses and forces the mixture through the transfer port to the other side of the piston. The downward movement of the piston will completely close the inlet port as in figure 1.33(b). Now first stroke is completed and the position is as that shown in figure 1.33(c).

Second stroke

The burnt gases still escape through exhaust port. The mixture transferred into the cylinder drives out the exhaust gases. This driving out of the exhaust gas is termed as scavenging. Now for the second stroke, the piston starts moving up. When it closes the transfer port and the exhaust port, the mixture in the cylinder will get compressed as shown

in figure 1.33(d) and when the piston reaches the top dead centre the second stroke is completed by completing the compression. At this stage the spark plug initiates the high intensity spark. Now spark ignition takes place to carry out the combustion of the mixture. The expansion of the burnt gases will now push the piston downwards to perform the working (power) stroke. The cycle gets repeated.

Working of two stroke diesel engine

First stroke

Two stroke diesel engine works on the principle of diesel cycle. The two stroke diesel engine consists of cylinder and piston arrangement, so that it can function as a pump in conjunction with the piston. At the beginning of the first stroke let us assume the piston is in the highest position at the end of the compression stroke. When the piston is at the top dead centre as in figure 1.34(a), the transfer port and exhaust port are covered by the bottom portion of the piston. This allows the air only to enter beneath the piston. When the piston descends, it compresses and forces the air through the transfer port to the other side of the piston. The downward movement of the piston will completely close the inlet port as in figure 1.34(b). Now the first stroke is completed and the position is as that shown in figure 1.34(c).

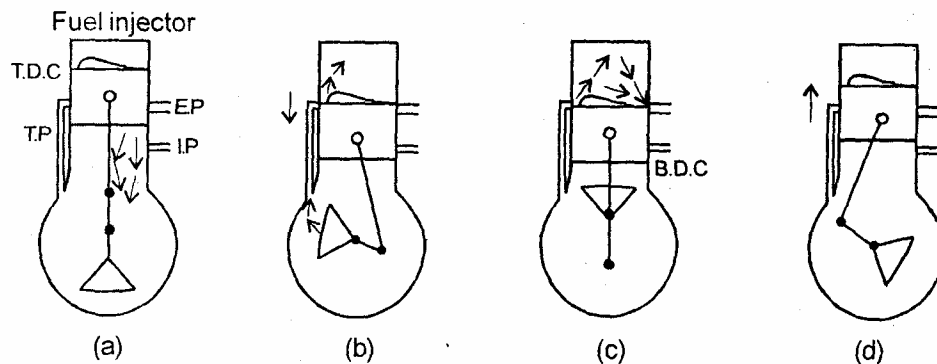

Figure 1.34 Two stroke diesel engine

Second stroke

The burnt gases still escape through exhaust port. The air transferred into the cylinder drives out the exhaust gases. This driving out of the exhaust gas is termed as scavenging. Now for the second stroke, the piston starts moving up. When it closes the transfer port and the exhaust port the air in the cylinder will get compressed as shown in figure (d) and when the piston reaches the top dead centre, the second stroke is completed by completing the compression. At this stage the fuel injector injects the diesel oil into the

compressed air in the cylinder in the form of fine spray. Now compression ignition takes place to carry out the combustion of the mixture. The expansion of the burnt gases will now push the piston downwards to perform the working (power) stroke. The cycle gets repeated.

1.10 ENGINE PERFORMANCE

Engine Performance refers to the variation of the output over the entire range of its operation. To have a complete study on engine performance, both the power and torque characteristics are to be considered. It is obvious that the engine is an energy conversion device. So the performance also refers to verify how effectively energy conversion is carried out. Moreover the engine performance study also indicates the efficiency and specific fuel consumption. Though there are many variables to be considered, the engine speed, load, air-fuel ratio and mean effective pressure are the important ones.

1.10.1 Performance of an engine

The Working of any mechanism, system or an engine is to be satisfactory for proper use and to meet the changes in demand of load and other requirements. Such suitable functioning of the engine is termed to be the performance. This performance can be tested, whenever required to note down the working condition and also to determine certain engine characteristics, either by varying the load on the engine and or speed.

The performance of the engine can be judged by

1. Indicated power and brake power – Mechanical efficiency
2. Fuel and air ratio – Volumetric efficiency
3. Speed
4. Thermal efficiency and heat balance sheet
5. Exhaust gas analysis

1.10.2 Terminologies

Indicated Power (I.P.)

The indicated power of an engine is power developed in the cylinder. It is measured by a form of pressure indicator connected to the cylinder head.

Brake Power (B.P.)

The brake power of an engine is the useful power available at the crank shaft of the engine for doing external work. This power is less than the actual power (indicated power) developed in the engine cylinder.

Frictional Power (F.P.)

The frictional power of an engine is the power loss in the cylinder and crankshaft due to friction between moving parts. It is the difference between indicated power and brake power.

Specific Fuel Consumption (SFC)

It is the amount of fuel consumed per unit power developed per hour.

Efficiencies

Mechanical Efficiency

It is the ratio of brake horse power to indicated horse power

$$\eta_{\text{Mech}} = \frac{\text{Brake power}}{\text{Indicated power}}$$

Thermal Efficiency

It is the ratio of BHP(or IHP) to the heat energy supplied by fuel. It is called brake thermal efficiency if calculated with BHP and indicated thermal efficiency if calculated with IHP.

$$\eta_{\text{bth}} = \frac{\text{BHP}}{\text{Heat supplied}}$$

Volumetric efficiency

It is the ratio of volume of air fuel mixture to the volume swept by the piston.

$$\eta_{\text{Vol}} = V_a / V_p$$

Relative efficiency

It is the ratio of indicated thermal efficiency to the corresponding ideal air standard efficiency.

$$\eta_{\text{Rel}} = \eta / 1 - (1/r)^\gamma$$

1.10.3 Testing of I.C. Engines

Purpose of testing an I.C. Engine

1. To determine the information which can not be obtained by calculations.
2. To confirm the validity of data used in design.
3. To find out the power developed under certain operating conditions.
4. To determine the fuel consumption in Kg/hr
5. To determine the quantity of lubricating oil, cooling water required per Whr.
6. To obtain information about the sources of loss.
7. To prepare heat balance sheet.

1.10.4 Load test

The Performance characteristics of an engine can be determined by applying load on it. Normally the engine fitted and used for Agriculture, Automobile, and Power generations etc. is subjected to varying and flexible loads and sudden demand. To test the suitability of the engine, on an experimental setup, the engine is subjected to different applied loads.

The performance characteristics like specific fuel consumption, Brake horse power, Frictional horse power, Indicated horse power and various efficiencies are calculated.

The Load is applied on the engine by any one of the following three methods

1. Mechanical load.
2. Electrical load.
3. Hydraulic load.

1.11 PERFORMANCE CURVES

Testing of engines is mainly to find out the Brake horse power, torque, fuel consumption, frictional horse power and specific fuel consumption at different engine speeds. The above relation and their variations with respect to the independent variable selected can be plotted by means of some performance curves. These curves can be utilized to compare the performance of different engines according to the service suitability.

Some of the important performance curves are shown in figure 1.37.

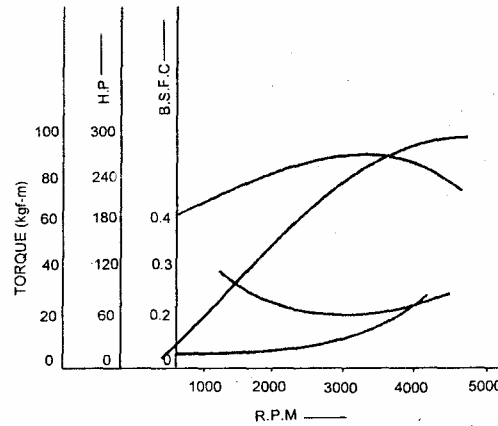

Figure 1.37 Performance curves

1.11.1 Torque vs engine speed

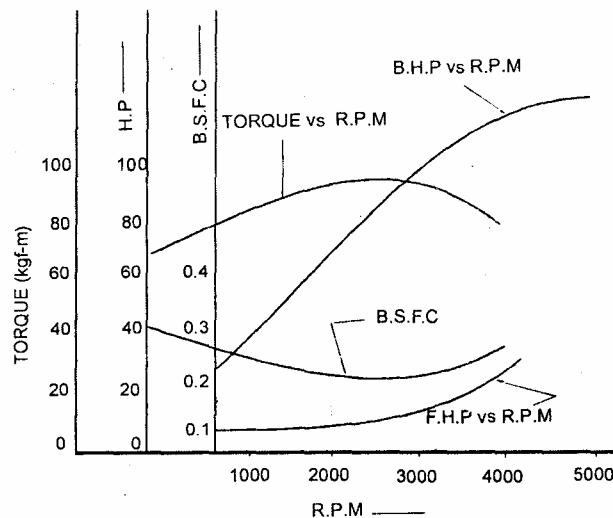

Figure 1.38

From the figure 1.38 during medium speeds, torques increases with speed. The volumetric efficiency is higher during this period, since cylinders get enough fuel-air mixtures to burn. Higher combustion pressure is needed to produce more power. At high speeds, the engine cylinders induct less amount of fuel-air mixture reducing the combustion pressures and hence the torque. Therefore the curve drops down.

Figure 1.38 indicates the torque curves for a diesel engine. By comparing the torque curves for petrol engine, the following facts are noted :

1. Diesel engine gives high torque at low engine speed.
2. Diesel engines operate almost at uniform torque over a higher range of operating speeds.

1.11.2 Brake horse power vs speed

The performance curves indicate that the Brake horse power steadily increases with the increase of engine speed, till a particular speed. The decrease in engine torque at higher speeds may be due to

- (i) The volumetric efficiency decreases at high speeds producing lower combustion pressure and hence lower engine power.
- (ii) Frictional losses increases with increase in engine speeds, decreasing the brake power.

1.11.3 Specific fuel consumption vs RPM

The specific fuel consumption decreases with increase of engine speed in both the petrol and diesel engine for the same swept volume. But the fuel consumption per horse power in case of diesel engine is lesser when the engine load decreases; the specific fuel consumption in petrol engine increases considerably. But in case of a diesel engine with the decrease in engine load, the specific indicated fuel consumption decreases, but the specific fuel consumption increases slightly.

1.11.4 Engine ratings

R. A. C Rating

The road tax is levied on automobiles according to R.A.C. formula or Royal Automobile Club formula.

According to this, horse-power = $D^2 \times N / 2.5$

Here D = Cylinder bore in inches

N = Number of cylinders

2.5 = a constant

The constant depends upon the following factors :

Mean effective pressure = 90 psi

Piston speed = 1000 ft. per. min

Mechanical efficiency = 75 percent

Modern engines develop nearly three times the rated power owing to high piston speeds.

1.11.5 Improvement of engine performance

The engine performance can be improved

1. by increasing the input energy
2. by increasing the engine efficiency.

The input energy can be increased by increasing the fuel consumption per unit time. This could be done by increasing the engine speed taking care that the volumetric efficiency at higher speeds is not affected. By super charging also the intake of Air-fuel mixture could be increased.

Increase in efficiency could be obtained by increasing the compression ratio. But beyond certain limit the increase in compression ratio will cause detonation and increased friction losses. So an optimum value of compression ratio has to be adopted.

1.12 ENGINE BALANCING

The automobile engines have reciprocating parts like piston and connecting rod. These creates vibrations while the engine is running. Moreover in case of four-stroke engine, there is one power stroke for every two revolutions of the crankshaft, so fluctuation is created. Therefore for smooth running of an engine, balancing is essential. This can best be solved in Multi-cylinder engine with proper firing order.

1.12.1 Types of balancing

Engine balancing is of two types

1. Power Balance
2. Mechanical Balance.

An Engine is considered to be in power balance if the power impulses occur at regular intervals with respect to the revolution of the crank shaft and each power impulse exerting the same force.

An engine is considered to be in mechanical balance when both the rotating and reciprocating parts are arranged in such a way that they counterbalance in operation and minimize the vibration.

The mechanical balance of an engine can be obtained by bringing the rotating part of an engine into static and dynamic balance. The rotating parts can be balanced conveniently but the balancing of reciprocating parts is not so easy. This is due to the weight of the pistons and connecting rods which reciprocates in different directions, producing considerable vibration.

The crank shaft is subjected to shocks while bringing the reciprocating parts to stop at the end of each stroke. These shocks over the crankshaft are termed as 'Primary Inertia Forces'.

The engines also have 'Secondary Inertia' forces due to the angularity of the connecting rods which produce secondary vibration.

It is to be noted, that for a perfect balance that every piston and a connecting rod are to be of same weight. Apart from this, the assembly of the crankshaft and flywheel also need a perfect dynamic balance to minimize vibration.

1.12.2 Firing order

The firing order refers to the sequence in which the power impulses occur in an engine or in other words a firing order refers to the order in which the cylinders deliver their power stroke.

The firing order plays a vital role to obtain the best engine performance and engine balance.

1.12.3 Engine balancing and firing order

Engine balancing is very closely related to the firing order. It is a well known fact that engine balancing could be improved by increasing the number of cylinders. With increase in number of cylinders, the power impulses for each revolution of the crank shaft also increases, giving a more uniform torque and smoother operations. In multi-cylinder engines if the power impulses are spaced equally, the power flow is continuous and less work is to be done by the flywheel in storing and releasing the energy, thereby reducing the vibration.

1.12.4 Four-cylinder engine : Balancing

Just for comparison and to study the engine balance an example of four-cylinder engine is considered. The arrangement of a four-cylinder engine with 180° crankshaft is shown in figure 1.39.

The movement of the piston 1 and 2 and that of 3 and 4 are in opposite direction. Thus, they balance each other, neutralizing the primary inertia forces and maintaining good mechanical balance.

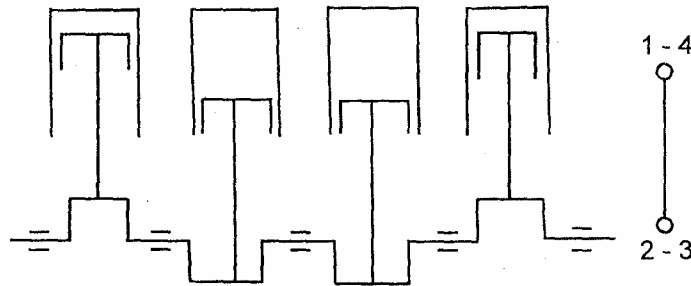

Figure 1.39 Four-cylinder engine : Balancing

But in case of four cylinder engine the secondary inertia forces acting on the reciprocating parts are not properly balanced. These unbalanced inertia forces bring secondary vibration at higher speeds. This defect is minimized to the maximum best in six-cylinders and eight-cylinder engines.

The table shows the power balance with different firing orders :- 1, 3, 4, 2 for table (1) and 1, 2, 4, 3 for table (2). Table(1) indicates the power balance with piston no. 2 moving upwards for exhaust stroke and piston no. 3 for compression. Table(2) indicates the power balance for the piston no.2 moving upward on compression and piston no. 3 for exhaust. Thus in both cases the power impulses are evenly distributed.

In other words, they are at 180° apart.

	I					II			
Cylinder	1	2	3	4	Cylinder	1	2	3	4
First	P	E	C	S	First	P	C	E	S
Revolution	E	S	P	C	Revolution	E	P	S	C
Second	S	C	E	P	Second	S	E	C	P
Revolution	C	P	S	E	Revolution	C	S	P	E

1.13 ENGINE TROUBLE SHOOTING

In order to keep the vehicle in perfect rolling and functioning condition, troubles or disturbances whenever felt, should be immediately diagnosed and removed. This process of identifying the causes and the remedial action is termed as trouble shooting. The probable causes for improper functioning of the vehicle may be either in the power unit or in the transmission unit or in other auxiliary systems explained so far. Just like giving first aid, it is preferable to locate the troubles and reduce their effects instantly. For slightly major repairs, it is better to take it to a Auto garage or service station. Of course, most of the difficulties in an Automobile can be settled by proper adjustments and replacements with some minor repairs. So it is essential to have a thorough knowledge of the process of trouble shooting charts of various components. In short, trouble shooting is a means of analysis, diagnosis and rectification of troubles.

The trouble shooting procedure informs what to do, when to do, and what is the order, etc., Mostly the troubles occur in ignition, electrical and transmission systems, which need immediate attention. The other common troubles arise in braking, steering, fuel, cooling, and the chassis systems.

The sluggish running of the motor vehicle is a frequent experience to all. The main reasons for such running, apart from lack of power are defects in the following:-

1. Ignition system,
2. Fuel system,
3. Starting system and
4. Cooling system

Trouble shooting - systems

For any particular vehicle, it is better to obtain or prepare a trouble shooting chart as a safe record. It is beyond the scope of this book to provide the chart for all the causes and remedies. Only some important troubles are analysed in this unit.

1. Engine does not start

Causes : a) Choked fuel supply, b) sticking of needle valve, c) flooded carburettor, d) dirty spark plug gap, e) discharged battery, f) ineffective opening of contact breaker points, f) poor compression.

2. Engine starts but stops suddenly

Causes : a) Choked filter and silencer, b) loose connection in ignition circuit, c) faulty fuel pump of carburettor over flow, d) fuel leakage in the line.

3. Engine misfiring

Causes : a) Faulty carburettor, b) dusty air cleaner, c) choked silencer, d) sticking of valves, e) defective spark plugs, f) defective wiring. g) defects in ignition circuit - incorrect timing.

4. Engine continues to run after switching off:

Causes : a) Engine overheating, b) defective ignition switch, c) carbon deposit in combustion chamber, d) spark plugs of incorrect heat value.

5. Engine overheating

Causes : a) Retard timing, b) too lean fuel mixture, c) leakage of water in the cooling system, d) loose fan belt, e) lack of lubrication, f) tight engine, g) brakes binding, h) excessive carbon deposit in engine cylinder.

6. Engine producing abnormal noises

Causes

- a) Worn out gudgeon pins and small end bearings,
- b) Worn out piston and rings,
- c) Worn out big - end bearings,

- d) Worn out crank - shaft main bearings,
- e) Ignition too far advanced,
- f) Wrong grade of spark-plugs,
- g) Loose flywheel or crank pulley,
- h) Excessive tappet clearance,
- i) Loose timing chain,
- j) Defective water pump bearing,
- k) Fan blades striking radiator or hose,
- l) Slipping fan belt.

7. Excessive fuel consumption

Causes :

- a) Improper adjustment of the carburettor
- b) Dirty air cleaner, leakage in the fuel line
- c) Excessive idling
- d) Dragging brakes
- e) Under inflated tyres
- f) Vehicle overloaded
- g) Unnecessary use of low gear
- h) Operating with partially closed choke
- i) Tight wheel bearings
- j) Incorrect wheel alignment.
- k) Incorrect spark plugs

8. Engine does not run slow or idling problem

Causes :

Choke valve partly closed, Incorrect idle adjustment, dirty air cleaner, damaged idle passage.

9. Engine does not pick-up speed

Causes :

Restriction in throttle valve operation, Restriction in fuel supply, Float level too low, Carburettor overflowing, Poor compression.

10. Clutch slipping

Causes:

No free play of pedal, worn out clutch plate, Oil grease or other such material on clutch facings, Excessively worn out pressure plate and flywheel.

11. Clutch dragging or spinning

Causes :

Oil or grease on clutch plate linings, clutch shaft out of line with engine, Clutch plate distorted, Cushion springs damaged.

12. Clutch judder

Causes :

Linings not making even contact, Pressure plate not parallel with flywheel, Bent clutch shaft.

13. Clutch rattling

Causes:

Worn out release bearing, worn out release fork, disconnected pedal return spring.

14. Gear slipping out of mesh

Causes:

Damaged ball races , plunger or spring locking selector shaft or fork, Bent shifter fork, Worn out grooves of selector shaft.

teeth for alignment of different gears on the respective shafts is carried out. The position and the number of shims are noted for proper refitting. The teeth of all the gears are inspected for roughness and any cracking. The crown wheel is checked for any distortion. All the oil seals are renewed.

While assembling, thrust washers, shims and distance pieces must be positioned correctly. Then using a dial test indicator on the casing, the position of the pinion shaft is checked for end wise movement. The clearance allowed in the design is adjusted by means of screw and nut provided in the casing. Thus, all sort of adjustments are made for proper clearance and smooth contact between the crown and the pinion wheel.

Other Automobile Overhauling Systems

The following assembly units are also to be inspected for overhauling.

1. Valve and valve operating mechanism
2. Carburettor
3. Pump
4. Ignition systems
5. Distributor
6. Brake system
7. Steering assembly
8. Shock absorbers
9. Steering wheel centering, wheel alignment, and suspension system.
10. Cooling system
11. Radiator (thermostat, fan belt, water pump)
12. Electrical systems
13. Lubrication systems
14. Wheels and Tyres.

1.14 GAS TURBINES

A gas turbine is an external combustion engine. The fuel used in a gas turbine may be Gasoline, Kerosene or diesel without any octane or cetane requirements, methanol Gasoline. A gas turbine in general consists of two sections - A gasifier section and a power section. Gasifier section includes compressor, combustion chamber; Power section includes the turbine and the transmission. This works on Brayton cycle. The circuit diagram is shown in the figure 1.40.

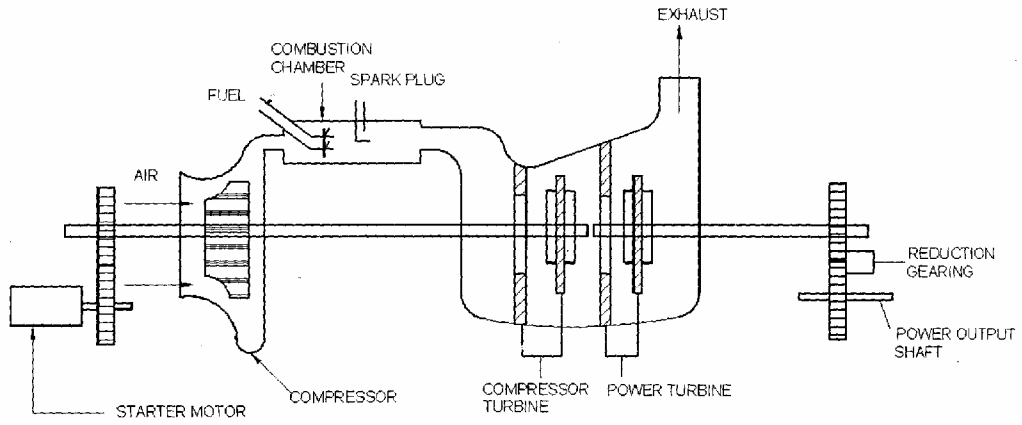

Figure 1.40 Principle operation of a gas turbine for automotive use

Initially atmospheric air is drawn into the compressor which may be of centrifugal or axial type. A multistage compressor would be needed to obtain the pressure ratio of 4 : 1 as required for automobile applications. The air gets compressed in the compressor, then the high pressure air enters into the combustion chamber. Can type combustion chamber is mostly used.

An inner chamber in the combustion chamber admits the primary air through swirl vanes. An injector nozzle is placed near the vane. The combustion chamber is divided into three zones - Primary, Intermediate and Secondary. A spark plug or burner is fitted to ignite the Air-fuel mixture. The main combustion occurs in the primary zone and the combustion reaction continues to release energy in the intermediate zone.

In the secondary zone, an additional quantity of air is supplied to reduce the temperature of products of combustion, to a safer limit.

The high pressure and high temperature gas then passes through the gasifier nozzle. The hot combustion gases pass through the compressor turbine and then through the power turbine where it further expands to give power. The compressor turbine is just to run the compressor, but the major motive power is developed by the power turbine.

The rotor of the compressor and the compressor turbine is mounted on the same shaft. A reduction gear has to be used for effective control of the turbine speed, because the turbine speed is much more than the conventional automotive engines. A starter electric motor is also included to run the compressor. To increase the thermodynamic efficiency of the turbine a heat exchanger is also included.

1.14.1 Advantages of gas turbine

1. Since there are no reciprocating parts it is easy to balance and free from vibrations.
2. Starting is very easy.
3. No need of cooling system.
4. Lesser consumption of lubricating oil compared to I.C. Engines.
5. Higher mechanical efficiency.
6. It is simple in design, light in weight and compact in shape.
7. Combustion is continuous without the necessity of further ignition.
8. It is smooth in operation with continuous performance.
9. Any distillate and cheaper fuels can be used.
10. The turbine exerts a smooth and continuous torque on the shaft.

Disadvantages of gas turbine

1. There is no engine braking and acceleration.
2. Since the speed varies from 25.000 to 50.000 rpm braking is not effective.
3. Difficult to obtain an effective transmission speed on road.
4. A high speed self starter with a large battery is required.
5. The large quantity of exhaust gases is a nuisance and hazardous in traffic.

1.15 AIR POLLUTION

Transportation is the main reason for air pollution especially in urban areas, where 60% of the air pollution is caused by automobiles only. The problem is of much concern in our country as the vehicular population is increasing at an accelerating rate every year.

The exhaust from the automobile engine contains serious pollutants of oxides of Nitrogen (NO_x) which are toxic. The oxides of Nitrogen react with the hydrocarbons in sunlight to form photochemical smog. The smog is a mixture of smoke and fog. Smog and other chemical on earth in the form of a dome are very harmful for eyes, throat and lungs. Smog can be seen in the atmosphere, but other pollutants like lead compounds, hydrocarbons and carbon monoxide may not be visible.

The contribution of NO_x from Petrol engine is higher than from the diesel engine and gas turbines.

Automobile pollutants

The main sources of pollutants in automobile are as follows :

1. Fuel tank - Gasoline vapour
2. Carburettor - Gasoline vapour
3. Crankcase - unburnt air-fuel mixture blown through the piston rings.
4. Tail pipe - unburnt gasoline, hydrocarbon, Carbon monoxide, nitrogen oxide and sulphur oxide.

The very high temperature in the automobile engines is the main reason for the pollution.

Main pollutants

The main pollutants contributed by automobiles are

- (1) Carbon monoxide (CO)
- (2) Unburned Hydrocarbons (UBHC)
- (3) Oxides of Nitrogen (NO_x)
- (4) Lead and other particulate emissions.

The contribution of pollutants, by source are as follows:

	Sources	Methods	Pollutants
1.	Fuel tank		
2.	Carburetor	Evaporative loss	15 to 25% of HC
3.	Crank case	Crank case blow by	20 to 35% of HC
4.	Exhaust system	Tail pipe exhaust	50 to 60% of HC and almost all CO and NO _x .

The pollution from the fuel tank is due to the temperature changes. When the temperature increases some portion of air and fuel vapour mixture from the tank is forced out through vent holes. The pollution from the carburetor is due to the evaporation of the fuel stored in the float bowl, due to engine heat. This leak of gasoline vapour from carburetor enters into the atmosphere.

The evaporative losses are the direct losses of raw gasoline from the engine fuel system; the blow by gases are the vapors and gases leaking into the crankcase from the combustion chamber and the pollutants from the exhaust pipe are due to incomplete combustion.

Air-fuel mixture trapped in the top land clearance and behind the top ring are unable to burn due to wall quenching effect. The cylinder forces this quenched gas past the piston ring and into the crankcase, along with some burned gases.

Most of the VOC (volatile organic compounds) emissions are from the tail pipe, these are controlled using catalytic reactors and by injecting air at the exhaust ports of the engine to burn emitted hydrocarbons in this high – temperature zone. However more than 20% of the uncontrolled automobile engine VOC emissions are from the crankcase vent and from the carburetor vent to the atmosphere. These emissions are controlled using a crankcase vent pipe to the engine air intake duct and a “carbon canister” absorption unit

Exhaust emissions are greatly affected by air-fuel ratio, ignition timing and design of engine.

Carbon monoxide : Carbon monoxide occurs only in engine exhaust. It is a product of incomplete combustion due to insufficient amount of air in the air-fuel mixture or insufficient time in the cycle for completion of combustion. The percentage of CO increases in idle range and decreases with speed. In passenger cars CO percentage has been found to be as high as 7 percent with rich mixtures and 1.25 percent with near stoichiometric mixtures. The complete elimination of CO is not possible and 0.5 percent CO should be considered a reasonable goal.

Carbon monoxide emissions are high when the engine is idling and reach a minimum value during deceleration. They are lowest during acceleration and at steady speeds. Closing of the throttle which reduces the oxygen supply to engine is the main cause of CO production, so deceleration from high speed will produce highest CO in exhaust gases.

Hydrocarbon : Unburnt hydrocarbon emissions are the direct result of incomplete combustion. Two of the important design variables are induction system design and combustion chamber design, while main operating variables are air-fuel ratio, speed, load and mode of operation.

Particular matters : Organic and inorganic compounds of higher molecular weights and lead compounds resulting from the use of TEL are exhausted in the form of very small size particles. About 75 percent of the lead burned in the engine is exhausted into the atmosphere in this form and rest is deposited on engine parts. Other constituents are phenols, acids, ketones, ethers, formaldehyde and acetaldehyde etc.,

Oxides of Nitrogen (NO_x) : Oxides of nitrogen which also occur only in the engine exhaust are a combination of nitric oxide (NO) and nitrogen dioxide (NO₂). The combustion of HC and NO_x in the presence of sunlight and certain atmospheric conditions produce photochemical smog.

ENGINE EMISSION CONTROL

The best way to control air pollution is not to produce the pollutants. For example, burning non-leaded fuels eliminates lead emission from automobiles, and nitrogen oxide emissions per mile of travel have been significantly reduced by redesigning engines. A possible alternative is to shift the location of the nitrogen oxides emissions – for example, from the automobile tail pipe to the stack of an electric generating station, by using electric or hydrogen-fueled cars.

Automobile pollutants can be controlled by,

- 1) Alternation in induction system.
- 1) Periodic servicing of ignition and carburetor systems.
- 2) The installation of a fuel tank with a built in chamber to provide an assured thermal expansion volume for the fuel.
- 3) Treatment of exhaust gas.
- 4) Reduction of lead in gasoline.
- 5) Fuel modification
- 6) Retarding ignition timing
- 7) Modification of combustion chamber configuration to reduce quench areas.
- 8) Lower compression ratio.
- 9) Reduced valve overlap.

Exhaust emission can effectively be controlled, by fuel modification. CO emission can be effectively reduced with reduction of HC and NO_x; and by selecting from propane to methane, the CO and HC emission can be greatly reduced.

Other solution include reducing emissions by using "add-on" devices. In the case of automobile, carbon canisters are used to adsorb hydrocarbon vapors emitted from the carburetor and the gas tank. The vapors are subsequently returned to the engine for burning. Use of fuel injection system is better way to reduce carburettor emission because it does not require venting to the atmosphere and it offers the potential for slightly improved fuel efficiency. In the automobile exhaust system, catalytic converters and air injection chemically reduce emissions of hydrocarbons.

Control of Nitrogen Oxides : By reducing the peak cycle temperature the effect of Nitrogen Oxides can be greatly reduced. The following are the common methods for controlling NO_x emission

- a) Exhaust gas recirculation (EGR)
- b) Water injection
- c) Cartelist

Catalytic Converter : This is used control the harmful exhaust emission by converting into other forms of harmless gases and liquid. As catalysts are used for emission conversion this is known as catalytic converter. There are two kinds of catalytic converter.

1. Two-way type and
2. Three way type.

In two way converter only hydrocarbons and carbon monoxide are converted nitrogen oxide remains same. But in three-way catalytic converter all the three are converted into carbon dioxide, nitrogen and water vapor. A catalytic converter is fitted in the exhaust system of the vehicle. This consist of a heated O₂ sensor and activated charcoal filter.

HEALTH HAZARDS OF AUTOMOBILE EXHAUST

The major pollutants as discussed above, in general cause burning of eyes, red eyes, irritated throat, trouble in breathing, nerve and brain damage etc.

CARBON MONOXIDE

Carbon monoxide inhalation in excess produces poisoning. It has an affinity for hemoglobin about 300 times that of oxygen and combines with hemoglobin to form carboxy hemoglobin-thus reducing the oxygen carrying capacity of blood. It may also combine with myoglobin and have effects on cytochrome oxidases. Most dangerous effect of CO poisoning manifests on central nervous system and myocardium. CO causes lung, kidney and cancer problems. It is responsible for increased carbon in blood, decreased oxygen transport, and heart disease. The other significance effects are:

1. Cardiac arrhythmias,
2. Hypotension,
3. Myocardial infarction

The other changes on Central Nervous System are;

1. Loss of intellect
2. Confusion and agitation
3. Headache
4. Irreparable brain damage
5. Coma
6. Cerebral edema
7. Cerebral infarction

SULPHUR DIOXIDE

SO₂ is highly soluble, and gets absorbed in respiratory system. This causes asthmatics, coughs, and bronchitis and fatigue problems. More over it is also responsible for acid rains.

Health effects of sulfur dioxide include exacerbation of asthma and COPD and respiratory tract irritation. Major health effects include effects on breathing, respiratory illness, breakdown of lung defenses, aggravation of existing respiratory and cardiovascular disease, influenza or asthma.

CARBON DIOXIDE

Carbon dioxide is a natural constituent of air. It does not take part in any significant chemical reaction with other substances in the air. However, its global concentration is rising above the natural level by an amount that could increase global temperature enough to affect climate markedly.

LEAD

Lead is added in the petrol as anti knocking agent.

Health effects of lead are mainly on central nervous system and impaired neuropsychological development occurs in children. Lead affects on cells to cause gametotoxicity and carcinogenicity, on embryo to cause embryotoxicity and teratogenicity. High lead exposures cause seizures, mental retardation, and behavioral disorders, high blood pressure and heart diseases.

OXIDES OF NITROGEN

This is a reddish-brown highly reactive gas. Health effects of oxides of nitrogen are respiratory tract irritation, bronchial hyperactivity, and impaired lung defenses, bronchiolitis obliterans causes bronchitis and pneumonia, lowers resistance to respiratory infections, and plays a major role in troposphere ozone formation.

HYDROCARBONS

Hydrocarbons exert their pollutant action by taking part in the chemical reactions that cause photochemical smog. Carcinogenic potential of hydrocarbon is the main health effect.

OZONE

This colorless gas reduces lung function associated with coughing, sneezing, chest pain and pulmonary congestion. High concentration of ozone causes eye irritation. Ozone is one of the strongest oxidizing agents released from automobile exhaust causes cough, substernal discomfort, bronchoconstriction, decreased exercise performance, respiratory tract irritation.

CAUTION

UNIT-II

RUNNING SYSTEM

ROAD WHEELS:

Wheels are as important of a vehicle as the ether parts. lithe parts being perfectly in working order, the vehicle can't move on the road, without wheels. The wheels not only support the weight of the vehicle, but also protects it from the ad shocks. Whereas the rear wheels move the vehicle, the wheel steers it to take a right or left turn. All the four heels must resist the braking stress and with stand side rust.

FJUNCTIONS OF WHEELS:

- 1.Strong enough to with stand the weight of the vehicle
- 2.Flexible to absorb the road shocks which are caused when the vehicle is on move.
- 3.It should be able to grip the road surface
- 4.Perfectly balanced dynamically and statically.
- 5.Light and easily remarkable.

TYPES OF WHEELS:

- 1.Disc wheel
- 2.Wire wheel or spoked wheel.
- 3.Magna wheels
- 4.Heavy vehicle wheels (three pieces)

DISC WHEEL:

This type of wheel (Fig) consists of a steel rim d a pressed steel disc. The rim is a rolled section, some times riveted but usually welded to the flange of the disc. e steel disc performs the function of the spokes. The wheel assembly is bolted to the brake drum. Some slots are genesis provided in the wheel disc for better cooling of the brake

CAUTION

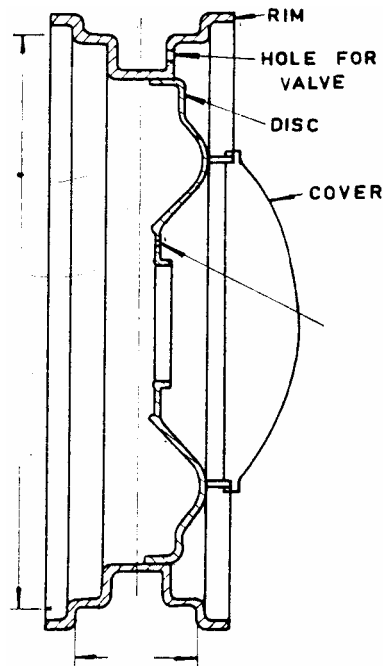

Fig Disc wheel

A separate cover is also provided on the wheel disc. A hole in the rim serves to accommodate tube valve.

This type of wheel is cheap, robust in construction and simple. It is most commonly used in heavy motor vehicle cars buses, trucks and tractors.

WIRE WHEEL OR SPOKED WHEELS:

Unlike the disc wheel, the wire wheel has a separate hub, which is attached to the rim through a number of wire spokes as shown in Fig 3.J. The spokes carry the weight and transmit the driving and braking torque in tension. The initial tension of the spokes can be adjusted by means screw nipples which also serve to secure the spokes to the rim. The hub is provided with internal splines to mesh with the splines provided on the axle shaft. A wing nut secures the hub on the axle shaft. The advantages of this

DRIVING TORQUE BRAKING TORQUE

WIRE WHEEL

CAUTION

This type of wheel are light weight and high strength, and above all it provides much better Cooling of the brake drum. It is also very easy to change the wheel when required because only one nut has to be opened.

MAG WHEELS:

Plain steel wheels, decorated with hub caps or wheel covers are used on cars to day. A variety of special wheels are available. These special wheels can be classified as styled steel or styled aluminum wheels. The mag wheel is very popular. It looks like a magnesium wheel which is very light. However for passenger cars, mag wheels are made of aluminium. Actually the term 'mag wheel' can mean almost any chromed, alluminium off set, or wide-rim wheel of spoke design.

HEAVY VEHICLE WHEELS (THREE PIECE):

Split rim wheels are used on heavy truck strainers, earthmovers and so on. They are heavily made and require a different method of disc installation. One split rim wheel has three pieces. the wheel assembly piece, flange and lock ring. The whole wheel and rim with tyre are removed as an assembly for the service. Then the lock ring and flange can be removed so that the tyre can be taken off the' rim. To tighten the wheel and also to increase air flow to the brake drum, large slots or holes are mag disc.

If you ever work on tyres mounted on split-rim wheels make sure all air pressure has released from the tube before begining to remove the lock ring or flange. If air pressure u still in the tube, it could blowthe tyre off the rim when the lock ring or flange is removed and it may seriously injure or fall on any one near by. Make sure the lock ring or flange is securely in place'before attempting to inflate the tyr.e.

TYRE

The tyre is mounted on the wheel rim. It hash two functions. First it is air filled cushions that absorb most of the shocks caused by road irregularities. Thus they reduce the effect of the shocks on the passengers in the car.

Second, the tyres grip the road to provide good traction. Good traction enable the car to accelerate, brake, and take turns with skidding.

TYPICAL TYRE

The use of solid tyres on automobiles is now absolute and only the pneumatic tyres are used univerversely. These pneumatic tyres are of two types vii. the conventional tyre with a tube and the tubeless tyre.

1. CONVENTIONAL TUBED TYRE

CAUTION

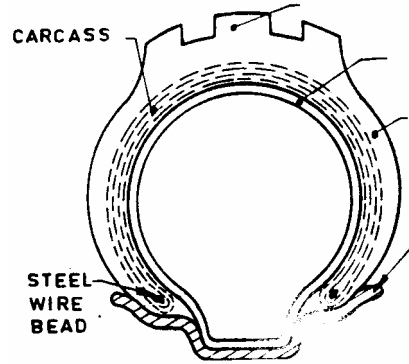
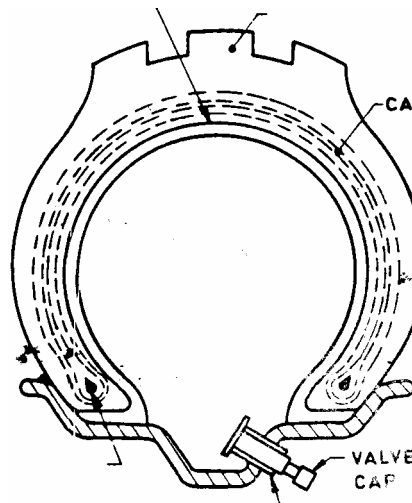

Fig gives the cross section of such a tyre. It consists of two main parts viz the carcass and thread. The car cass is the basic structure taking mainly the various leads and consists of a number of plies wound in a particular fashion from the cords of rayon or any suitable material. The thread is generally made of synthetic rubber and on the design of the tyre thread depend on various tyre properties viz, the grip, the noise and £h wear. At' the inner edge, beads are formed by forcing with steel wires. This provides the tyre with strong shoulders for bearing against the wheel rim.

2. TUBELES TYRE

does
tube,
the tyre
non-
to the
tyre is



This type of tyre not need a separate tube, instead the air under pressure is filled with for wh~ch purpose a return valve is fitted rim. The inner constructions of the almost tne same as

CAUTION

that of tubed tyre, except that it is lined one side with a special air retaining liner as shown in fig 3.36 This type has the advantage that in case of any hole being caused in the tyre, some can be repaired simply by plugging, where as in case of the conventional tyres, it takes quite some time to remove the tube for repair. Apart from this,, a tube less tyre retains the air

pressure for long periods even when punctured provided the same is held in place.

RADIAL PLY AND CROSS PLY TYRES:

Skeleton of the tyres is of three types.

1. Cross ply or bias piy
2. Radial ply
3. Belted-bias type.

1. CROSSPLYTYPE:

In this type, the plycords are woven at an angle to the tyre axis. There are two layers which run in opposite directions as shown in the Fig3.37a However the cords are not woven like warp and wept of ordinary cloth, because that would lead to rubbing of the two layers and thus produce heat which would damage the tyre material.

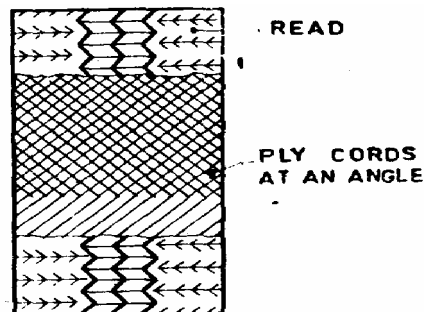

CROSS PLY

This typ. of tyres ~eve better wear and, road holding characteristics. They are fitted both front and rear wheels. But they must not be fitted on the front wheels only

RADIAL PLAY TYPE:

CAUTION

CAUTION

CAUTION

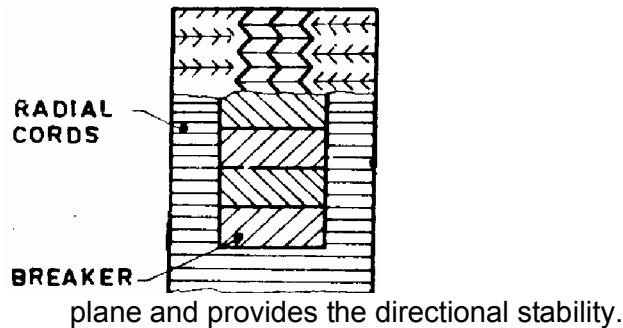

plane and provides the directional stability.

STEERING SYSTEM:

For effective control of the vehicle through out its speed range with safety and without much conscious effort on wide variety of road surfaces. -providing bumps and bounces to the vehicle, proper steering is necessary. The control of an automobile is done by means of a steering system which provides directional changes to the moving automobile and with the help of accelerator and gear shift lever as well as the brakes.

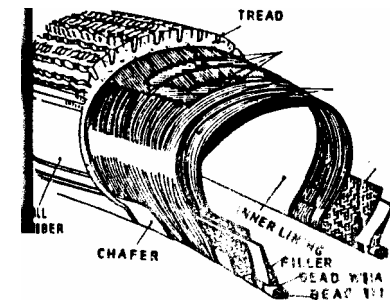

In this type the plycords run in the radial direction ie in the Direction of the tyre axis. Over this basic structure an number of breakes strips must be flexible but inextensible, so that no change of circumference takes place with bing in the amount of inflation. With out the breaker trips radial plies would give very soft ride but there will not a any lateral stability. The in extensible breaker strip shaves like a girder in its own

CAUTION

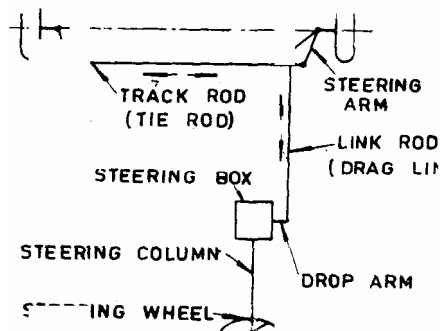

The steering in addition to directing the vehicle in a particular direction must be arranged geometrically in such a way so that the wheels undergo true rolling motion without slipping or scuffing. Moreover, the steering must be light, stable with a certain degree of self-adjusting ability.

FUNCTION OF A STEERING SYSTEM:

To convert the rotary motion of the driver's steering wheel into the angular turning of the front wheels as well as to multiply the driver's effort with leverage or mechanical advantage for turning the wheels *fairly easily* is the function of the steering system. In order to prevent the road shocks from being transmitted to the drivers and the passengers, the steering system should also absorb these shocks.

ACKERMAN PRINCIPLE OF STEERING MECHANISM:

The main function of the steering system of a vehicle is to convert the rotary movement of the steering wheel into angular turn of the wheels. For perfect steering we must always have an instantaneous centre about which all the wheels must rotate. For this purpose inner wheel has

4.7.2.1. CAMBER:

to turn more than the outer wheel. To achieve two types of mechanisms, have been devised viz,

Straight the Davis and Ackermann steering mechanism. Out of these Ackermann mechanism is almost universally used. Referring to the Ackermann steering mechanism the track rod is placed behind the axle beam. The track arms AB and CD are suitably inclined to each other. This system gives true rolling of the wheels in three positions of the stub axles. One when the wheels are parallel and the other two corresponding to the turn to left or right. In any other position the axes of the stub axles do not intersect on the axis of the rear wheels. The Ackermann linkage is not complicated therefore it is used almost universally. When the track rod is moved to the right during turn, it pushes almost at a right angle against the right knuckle arm. The left end of the track rod however, not only moves to the right but also swings forward as shown in so that the left wheel is turned an additional amount. Therefore the angle of the inner wheel with the axle is greater than that of the outer wheel is 90° greater than δ . Similarly when a right turn is made the right wheel will be turned an additional amount over that which the left wheel turns.

STEERING GEOMETRY:

When an automobile makes a turn, in order to avoid the slipping of the tyre and over turning of the vehicle, each wheel of the vehicle must roll on an arc having a common centre with the arcs made by the other wheels of the vehicle. The most important feature of a vehicle's steering is its ability to maintain it on a straight path or deviated from at the will of the driver. Over a wide variety of roads, this control is to be effected with little conscious effort on the part of the driver. Further for effective control of the steering wheels must rotate with a true rolling motion free from side drag under all conditions.

The angular relationship among the front wheels, the front wheel attaching parts and the car frame is known as steering geometry. It also involves the angle of steering axis or king pin away from the vertical, the pointing in of the front wheels, the tilt of the front wheels from vertical. The various factors entering into the front end geometry and influencing the steering ease, steering stability, riding qualities of the car and having a direct effect on tyre wear are camber, king pin inclination, toe in, toe-out on turns, caster, etc.

The angle between the centre line of the tyre and the vertical line when viewed from the front of the vehicle is known as camber.

When the angle is outward, so that the wheels are further apart at the top than at the bottom, the camber is positive. When the angle is inward, so

4.7.2.1. CAMBER:

that the wheels are closer together at the top than at the bottom, the camber is negative.

Any amount of camber, positive or negative, tends to cause uneven or more tyre wear on one side than on the other side. Camber should not exceed Excessive camber prevents the tyre from having correct contact with the road which causes it to wear only on the side directly beneath the load. Unequal camber causes vehicle to roll in the direction of the wheel having greater camber which upsets directional stability and tends to scuff the tread on the opposite tyre.

KING PIN INCLINATION

The angle between the vertical line and centre of the king pin or steering axle, when viewed from the front of the vehicle, is known as king pin Inclination or steering axle inclination.

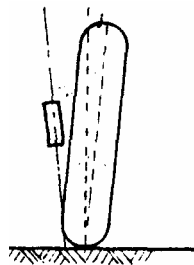

Positive Camber Angle

The angle between the centre line of the tyre and the vertical line when viewed from the front of the vehicle is known as camber Kingpin Inclination. When the angle is out ward, so that the wheels are farther apart at the top than at the bottom, the camber is positive. When the angle is inward, so that the wheels are closer together at the top than at the bottom, the camber is negative.

Any amount of camber, positive or negative, tends to cause uneven or more tyre wear on one side than on the other side. Camber should not exceed 20,

Excessive camber prevents the tyre from having correct contact with the road which causes it to wear only on the side directly beneath the load. Unequal camber causes vehicle to roll in the direction of the wheel having greater camber which upsets directional stability and tends to scuff the tread on the opposite tyre.

4.7.2.1. CAMBER:

CASTER:

In addition to being tilted inward towards the centre of the vehicle, the king pin axis may also be tilted forward or backward from the vertical line. This tilt is known as

The angle between the vertical line and the king pin centre line in the plane of the wheel (when viewed from the side) is called the caster angle. When the top of the king pin is backward the caster angle is positive, and when it is forward the caster angle is negative. The caster angle in modern vehicle is from 2 to 8-The caster produces directional stability by causing the wheels to lead or follow in the same direction as the vehicle travel. When both the front wheels have positive caster the vehicle tends to roll out or lean out on turns. But if the front wheels have negative caster, then the vehicle tends to back or lean in on turns. There is another important effect of the caster angle, positive caster, tries to make the front wheels toe-in. With positive caster, the vehicle is lowered as the wheels pivot inward. Thus, the weight of the vehicle is always trying to make the wheel toe-in with negative caster the wheels would try to toe-out. The positive caster increases the effort required to steer tries to keep the wheels straight ahead. This makes steering easier.

TOE-IN

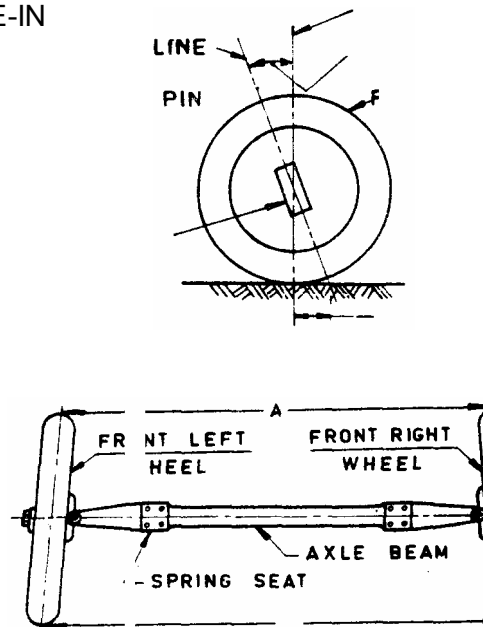

The front wheels are usually turned in slightly in front so that the distance between the front ends A is slightly less than the distance between the back ends B, when viewed from

4.7.2.1. CAMBER:

The amount of toe-in is usually 3 to 5mm. The toe-in is provided to ensure parallel rolling of the front wheels, to stabilize steering and to prevent side slipping and excessive wear. It also serves to offset the small deflections in the wheel-support system which come out when the car is moving forward. Although the wheels are set to toe-in slightly when the car is standing still, they tend to be parallel on the road when the car is moving forward. Some alignment specialists set the front wheels in 'straight away alignment' in preference to "toe-in" adjustment.

TOE-OUT

Toe-out is the difference in angles between the two front wheels and the car frame during turns. The steering system is designed to turn the inside wheel through a larger angle than the outside wheel when a turn is made. This condition causes the wheels to toe-out on turns, due to the difference in their turning angles. When the car is taking a turn, the outer wheels roll on a radius than the inner wheel, and the circles on which the two front wheels must roll are concentric. Therefore the inner wheel must make a larger angle with the car frame than that of the outer wheel makes. Toe-out is secured by providing the proper relationship between the steering knuckle arms, the tie rods and pitman arm.

STEERING LINKAGES:

The steering wheel is mounted at the top of the steering column and it controls the motion of the stub axles. The motion of the steering wheel is transmitted through the leverage between the steering wheel and the stub axles. Due to leverage system the effort that has to be applied to the steering wheel in order to overcome the friction opposing the turning of the road wheels is minimized. For steering linkage for rigid control the system is so designed that the steering wheel turns through larger angles than the stub axles at the road turns. The amount of leverage depends upon the weight of the vehicle, and the type of tyre.
Steering Linkages For Independent Suspension

To transmit the motion, several types of steering linkages are used between the pitman arm and the steering knuckles of the stub axles are shown in When the steering wheel is turned the pitman arm swings inwards or backwards and forwards directions. This movement displaces the stub axles from their straight position by the linkages Thus the steering linkage is a connection of various links between the steering gear box and the front wheels.

4.7.2.1. CAMBER:

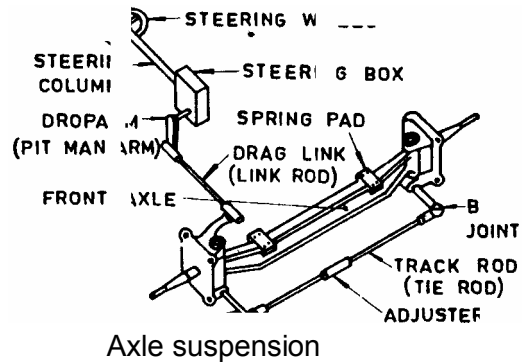

TYPE OF STEERING GEAR BOX

The steering gear is a device for converting the rotary motion of the steering wheel into straight line motion of the linkage with a mechanical advantage. The steering gears are enclosed in a box called the steering gear box. There are many differential designs of steering gear box, the important are discussed below.

CAM AND DOUBLE ROLLER STEERING GEAR BOX:

Fig illustrate the cam and double roller steering used on commercial vehicle. It consists of a cam gear on the input shaft with rotating double roller on the rocker shaft.

A two roller is fastened to the rocker shaft so that it meshes with the cam gear. The cam gear is formed on the bottom of end of the steering shaft. The outer end of the cross shaft is formed in the spindle to fix the drop arm. As the cam rotates, the inner is compelled to follow the cam and in doing so causes the rocker shaft to rotate, thus moving the drop arm. The contour of the cam is designed to mesh with the arc made by the roller, so maintaining a constant depth of mesh and evenly distributing the load and wear on the mating parts.

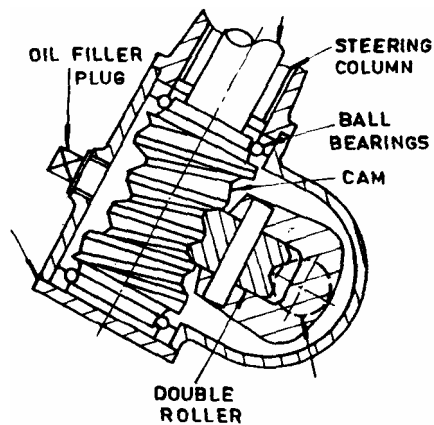

CAM AND TWIN LEVER STEERING GEAR BOX

Cam and Twin Steering Gear Box

Fig illustrate the cam and twin lever steering gear used in commercial vehicle. It consists of a constant diameter worm, called a cam in

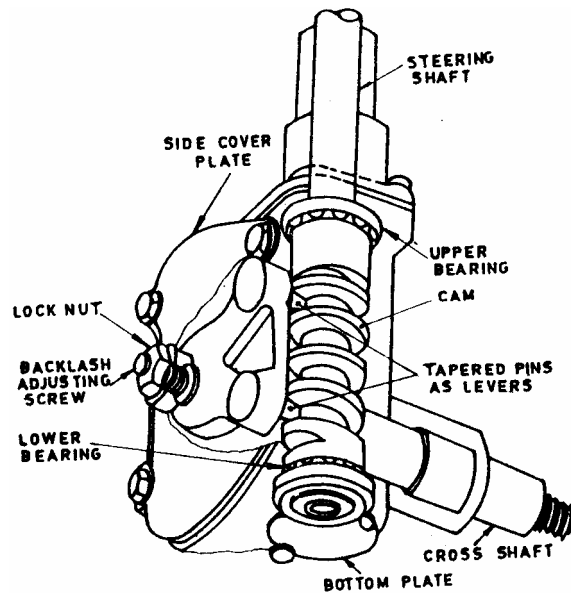

in this case, on the Input shaft and a cone shaped stud on the lever which follows the helix on the cam. The cam is cylinder~ I in shape, its actuating part being a groove of variable pitch wade narrower at the centre than at the end. This provides non-reversibility in the centre part of the cam where most of the car Steering takes place. The twin levers are

mounted on the cross shaft and are located so that the studs engage the cam from the side. When the cam is turned, the studs move along the cam groove to cause the lever to swing through an arc, and thus turning the cross shaft.

RACK AND PINION STEERING GEAR BOX:

This is very simple and common type mechanism, the system is shown in simplified sketch This type is very well suitable in an independent suspension system.

The system consists a rack housed in tubular casing. The casing is supported on the frame near its ends. The ends of the rack are connected to the track rods with the help of ball end. socket joints. The pinion shaft is carried in the plain bearing housed in casing. The pinion is meshed with the rack and the clearance is adjusted with the adjusting screw. when the pinion is given rotary motion with the steering wheel then the rack slides in either sides. The sliding motion of the rack is used through the track rods to the wheels in desired side

2) To safe gaurd the occupants from road shocks.

RECIRCULATING BALL STEERING GEAR BOX:

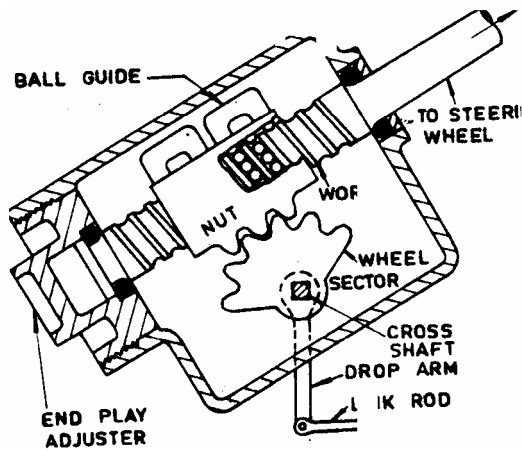

Recalculating Ball Type Steering Gear

Fig shows the recirculation type of steering gear. The input shaft portion of this gear has a semi circular grooved helix with constant lead that provides one half of the path of travel for the recirculation balls. The other half of the path is provided by a mating semi circular grooved helix cut on the inside of the follower nut.

FRONT AXLE

The front axle is used to carry the weight of the front part of the vehicle as well as to facilitate steering and absorb shocks due to road surface variation. It must be rigid and robust in construction. It is usually steel drop forging having 0.4 % carbon steel or 1 to 3 Nickel steel.

TYPES OF FRONT AXLES:

Usually there are two main types of the front axles.

1. Live front axle
2. Dead front axle.

The front axles are usually dead axles because they do not rotate. A live front axle, as compared to the dead axle has the additional function of transmitting the driving power taken from a transfer gear box to the front wheels having a different swiveling mechanism. The dead front axle has sufficiently rigidity and strength to transmit the weight of the vehicle from

- 2) To safeguard the occupants from road shocks.

springs to the front wheels. The ends of the axle beam are shaped suitably assemble The stub axle, The ends of the beam are usually shaped either as yoke or plain surface with drilled hole for connecting the sub axle assembly.

A typical front axle with stub axle is shown in An other front axle assembly with stub axle and track rod is shown in shows front axle components with steering linkage. facilitate steering and absorb shocks due to road surface vibrations. When there is no braking system in the front wheels of the vehicle then there will be only, bending load on the axles therefore a simple forging of I-beam section is used. If there is braking systems in the front wheel the ends of the axle are given proper shapes to carry the stub axles and the seats are made to attach the springs between the ends. The downward sweep is given to the axle beam at the central portion to keep a low chassis. This type of axles are made of I-sections in centre portions, while the ends are made either circular or elliptical. With this construction it takes bending loads due to the load of the vehicle and also torque due to braking of the wheels.

STUB AXLE:

The front road wheels are mounted on the stub axle themselves are connected to the front axle by means of king pin. Vertical loads are taken by a steel washer or a thrust bearing located either on the top form of stub axle or between the lower fork and the under side of the axle

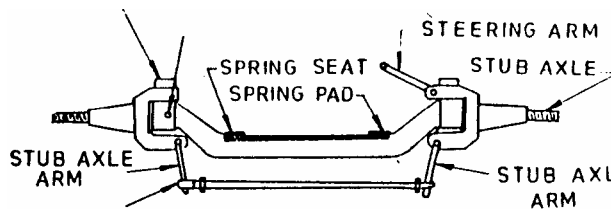

2) To safe gaurd the occupants from road shocks.

SUSPENSION

The frame as well body of the vehicle is attached to the rear axle and the front axle by springs. These springs damp the road shock transmitted to the body structure by the wheels when they travel over the road. In this way the springs are the protecting units supported directly by the frame of the vehicle. Therefore all the parts which perform the function of protection are collectively called a suspension system. These springs are generally of the laminated leaf type, coil type, torsion bar type and may be of any other special type according to the need. These springs provide a best suspension system to the vehicle thereby protecting the passengers and load from jerks, The suspension system of vehicle is divided in to (i) the front-end suspension and (ii) rear end suspension.

FUNCTIONS OF SUSPENSION SYSTEM

- 1) To prevent the road shocks from being transmitted to the vehicle frame.
- 3) To provide good road holding while driving, cornering and braking.
- 4) To maintain proper steering geometry
- 5) To preserve vehicle stability in pitching and rolling.

FRONT INDEPENDENT SUSPENSION

Independent suspension has become almost universal in the case of front axle due to the simplicity of construction of such a suspension system. In this type of suspension, each front wheel is independently supported by a coil, torsion bar or leaf spring. Almost all the passenger cars now use the independent front suspension. in which the coil spring arrangement is the most common.

ADVANTAGE OF INDEPENDENT FRONT SUSPENSION

1. The independ. it front suspnsio provides more space for engine accommodation.
2. It enables front springs to be arranged for enough, apart to to propose under steer conditions, which is preferable to oversteer.
3. It may provide after suspension. because the low spring rate enables large wheel movement.
4. One beams axles, spring deflection affects the caster. angle, especially when braking or accelerating. causing the axle to twist !~between the stub axle and the seats. Thug effect on the steering geometry is overcome with independent front Suspension.
- S. The unsprung weight is low. The weight of the chassis and body to
2) To safe gaurd the occupants from road shocks.

relative to that of the wheels and axle is known as the unsprung weight. the unsprung weight is heavy, the chassis/body combination has high inertia or, resistance to change of state, and the wheels tend to move later than the chassis / body.

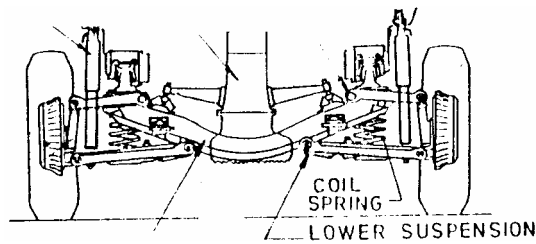

causing wheel wobble or shimmy.

COIL SPRING FRONT INDEPENDENT SUSPENSION

6. The independent front suspension reduce the tendency of this rotating wheels to turn about the king pins, due to gyroscopic action,

2) To safe guard the occupants from road shocks.

This type is used on a majority of passenger cars. This design permits either front wheel to react to changes in the road surface level without affecting the opposite wheel. A typical coil spring type independent front suspension arrangement is shown in Fig

longitudinal Axis Independent Front Suspension

The steering knuckle is pivoted at each end to the upper and lower control arms at the ball joints. The upper control arms, in turn are pivoted to the frame cross member at their inner ends by means of nibbler bushed or hardened steel threaded bushed. Control arms are usually V or wish bone shaped

below. As can be seen from the illustration, the lower control arm is longer than the upper one, The lower control arms longer than the upper one. The arrangement of the linkage is such that the point of road contact of the tyre moves up and down in a straight line during all normal movement of the control arms. and thereby avoiding the tyre Scrup. This is some times called knee action springing.

The two helical coil spring (one on each side) are supported at their lower ends in seats that are attached to the control arms. The upper ends of the are compressed against saats in th9 A shock absorber usually is employed to control the reaction of the coil springs.

lower
lower
springs
frame.
each of

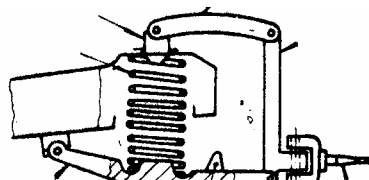

TORSION BAR FRONT INDEPENDENT SUSPENSION

The system contain a torsion bar as shown in the Torsion bar is simply a rod acting in torsion and taking shear stress only. The amount of energy stored per unit weight of material is nearly the same as for coil springs. Torsion bars are often used will independent front suspensions. Hence it is termed torsion bar front independent suspension. The bar is fixed to the frame, while the other end is fixed to the end of trie wheel arm and supported the bearing. The other end of the wheel arm is connected to the wheel hub. When the wheel strikes a bump, it starts vibrating up and down, thus exerting torque on the torsion bar, which acts as a spring. Torsion bar spring is lighter as compared to leaf springs and also it occupies less space. Some times the torsion tubes are used instead

2) To safe gaurd the occupants from road shocks.

DROP ARM

of the bars, the former being stiffer than the latter ones. There are two main disadvantages of the torsion bar suspension. The first is that it does not take the braking or driving torque so that additional linkages have to be provided for that purpose. The second disadvantage is the absence of friction force, and hence of damping which is a necessity to control the vibrations produced due to road.

TRANSVERSE LEAF SPRING : SUSPENSION

This type of transverse leaf spring is arranged transversely across the vehicle instead of parallel to the frame. As shown in Fig. 48 this spring is bolted rigidly to the frame at its centre. The ends of it are shackled to the axle

This type of suspension is the cheapest one, but has the disadvantage that the springs in this case are attached to the frame at only places, which imparts the vehicle a tendency to roll easily when it runs fast on sharp corners.

REAR SUSPENSION:

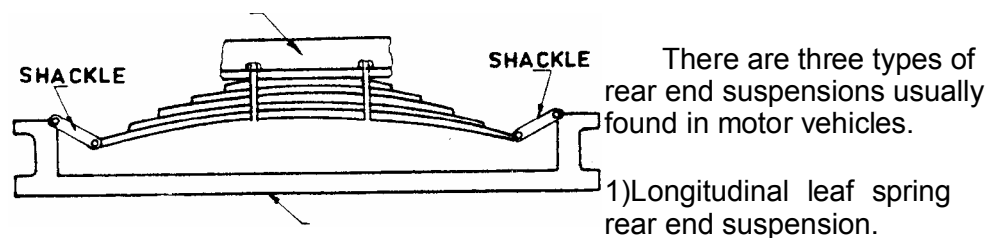

2) Transverse leaf spring rear end suspension.

3) Coil spring rear end suspension.

LEAF SPRING SUSPENSION:

Longitudinal leaf spring suspension is generally used in conjunction with the Hotchkiss drive. The leaf springs must be made strong and resilient enough to transmit the driving thrust and torque and to resist side ways, in addition to support the spring weight of the body. The spring weight is kept as less as possible, in order to improve the side of the vehicle. Because the springs do not generally support the wheels, rims, tyres, brakes and rear axle, the

2) To safe guard the occupants from road shocks.

weight of these parts is called spring weight. is clamped to the rear axle housing by U-bolts, its each end is pivoted to the frame, by means of eyes formed in the ends of the longest leaf.

The spring consists of a number of [eaves called blades. These blades vary in length. The composite spring is based upon the theory of a beam of uniform strength. The lengthiest blade has eyes on its ends. This blade is called, master leaf. All the upper sides and edges of all the springs are hot peened to increase their resistance to fatigue. All the blades are bound together by means of steel strips.

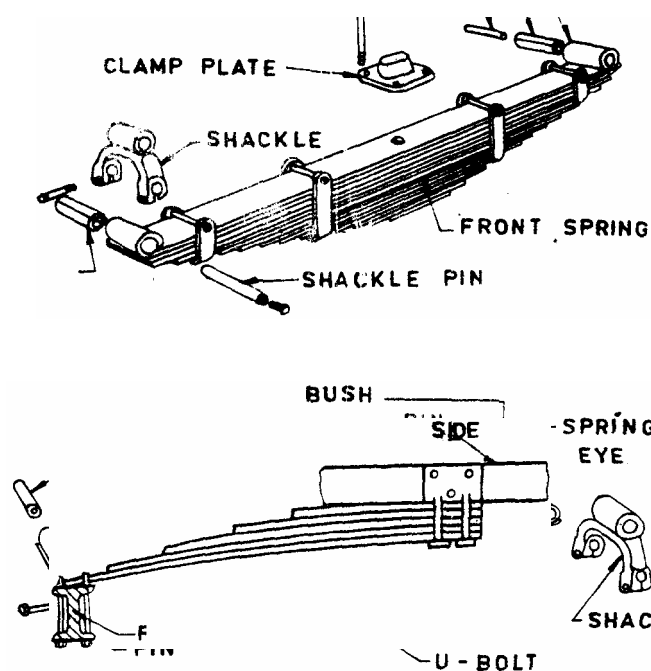

The spring is supported on the axle, front or rear. One end of the spring is mounted on the frame with a simple pin, while on the other end, connection is made with a shackle. The spring elongates in compression and shorten in expansion, This change in length of the spring is compensated by the shackle. At the intermediate position

of the spring length, the rebound clips are located. They are loose enough to permit the leaves to slide one on the other, and yet tight enough to hold these leaves together when the spring rebound. The spring eyes are usually provided with bushings or some anti frictional material such as bronze or rubber. Shackles are a sort of links by means of which leaf springs are connected with the chassis frame. The shackles' provide swinging ability to the leaf springs. Due to shock on the road wheel, the spring flattens up and increase in length rebound the spring assumes back shape there by in length. The shackles make the springs swing in and out.

2) To safe gaurd the occupants from road shocks.

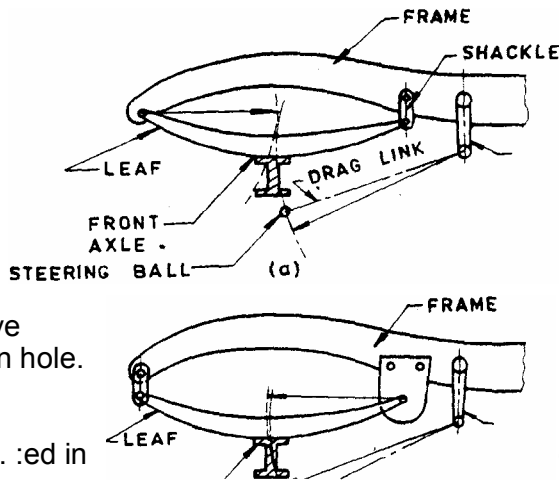

DROP ARM

One end of the link is connected with the chassis frame and through the end connection is made with the spring by means of the shackle bolt or pin. The shackle pin contains a hole at which a grease nipple is screwed. Lubrication is fed through the shackle

Different types of shackles are used in different types of vehicles. Which are

- 1) 'U' type
- 2) 'Y' type (Most commonly used one)
- 3) Link type.

The shackle position in front and rear end are shown in Fig

REAR WHEEL INDEPENDENT SUSPENSION

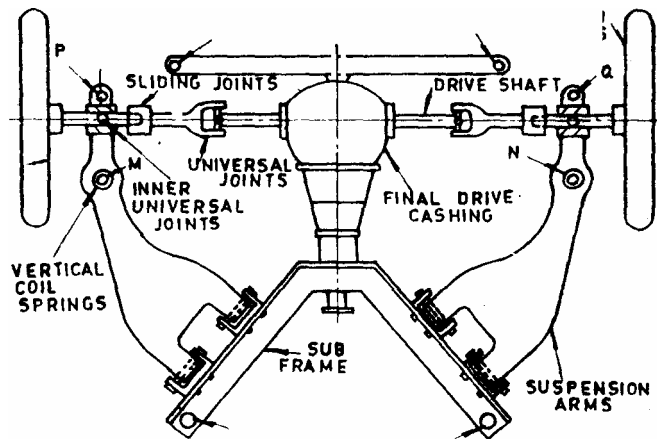

The rear wheels of the general vehicles are power driven therefore considerable difficulties are there to provide independent suspensions. But looking some advantages of independent rear suspensions over the rigid axle type it is used in some vehicles. Referring Fig. 4. 13 M. and 'N' are two

- 2) To safeguard the occupants from road shocks.

DROP ARM

coil springs in vertical positions and are mounted on the suspension arms. The arms are jointed on rubber bushes carried by the sub-frame. The sub-frame incorporates Rear Wheel Independent Suspension the final drive tasing and which is mounted on the body structure on the four rubber mountings A, B, C .and D. The other ends of the suspension arms are connected with the drive shafts in such a way that the shafts may be housed inside the ends with universal drives. One sliding joint is also provided between the two universal joints. To release the stresses gradually two shock absorbers are provided at the tail of the suspension arms. A line diagram of this type is also shown in Fig

Some of its drawbacks are:

- 1)The initial cost is high
- 2)Greater maintenance required
- 3)Misalignment of steering geometry with the wear of components.

TRANSVERSE SPRING TYPE

The upper ends of the wheel bearing supports are attached to the ends of the springs and the lower ends are attached to the dampers as shown in fig. The half shafts are driven via universal joints at the differential end.

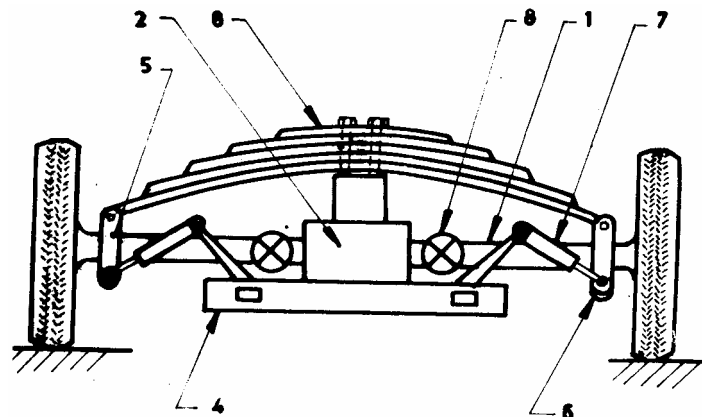

Transverse Spring Rear

- 2) To safe gaurd the occupants from road shocks.

37373737264.5 SHOCK ABSORBER:

Independent Suspension bearing support. The spring is mounted above the differential unit. Dampers are inclined and damp down the vibration of the spring and the wheel bearing supports. In this arrangement chassis is kept below the transverse spring.

Advantages:

1. Unsprung weight is greatly reduced
2. Provide comfortable drive
3. Less spring deflection

The shock absorber is a device which introduces resistance to the motion of the spring and road wheel so as to damp out vibrations. This resistance is obtained by causing a fluid to pass at high speeds through small holes. The energy absorbed depends upon the viscosity of the fluid, and appears as heat in the fluid. The advantage of the fluid type is that the fluid resistance is proportional to the square of the speed of flow through the orifices and so increases rapidly with the speed of the suspension movement.

CONSTRUCTION:

The device consists of two valves, A and B. Rod G is attached to the two-way valve A, while another, similar two-way valve B is attached at the lower end of cylinder C. There is fluid in the space above valve A, below valve A and also in the annular space between cylinder C and tube D, which is connected to the space below the valve B. H is a gland in the head I and any fluid scraped off by rod G is brought down into the annular space through the

- 2) To safe guard the occupants from road shocks.

4 10 .sI BRAKE SHOES:

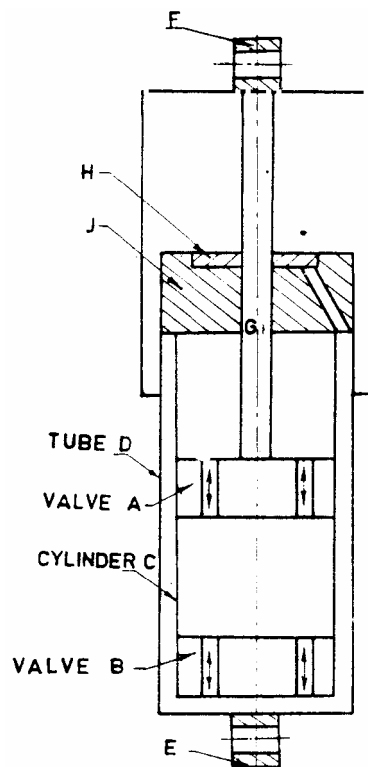

Telescopic Type Shock Absorber

inclined passage as shown in the head. The eye E is connected to the axle. While the eye F is attached to the chassis frame. The fluid generally used in shock absorbers is a mixture of 60 percent transformer oil and 40 percent turbine oil.

ACTION OF THE SHOCK ABSORBER

When the vehicle has come across a bump, then eye E would move up and thereby the fluid will pass from the lower side of valve A to its upper side. But since the volume of the space above A is less by the volume of the rod G, the fluid will also exert its pressure on the wheel.

BRAKE

BASIC REQUIREMENTS OF A BRAKE:

1. The brake must be strong enough to stop the vehicle with a
- 2) To safeguard the occupants from road shocks.

4.10.1 BRAKE SHOES:

minimum distance. The Distance should be the shortest during Emergency braking. The distance moved by the vehicle after the application of the brake is known as "braking distance".

2. The brakes must have good antifade Characteristics. In other words the brakes should not lose their effectiveness on prolonged application. This is only possible by- proper and effective cooling of brakes.

PURPOSE OF BRAKES:

1) To control the speed of the vehicle as well as to stop it when and where desired quickly and efficiently without skidding.

2) To keep the vehicle in any possible position after it has been actually brought to a complete rest when the driver is not present.

These purposes are accomplished by providing two independent braking systems in a motor vehicle, i. e. service brake and a parking or emergency or hand brake.

MECHANICAL BRAKES:

In the motor vehicle the wheel is attached to an auxiliary wheel called a drum. The brake shoes are made to contact this drum. In most designs, two shoes are used with each drum to form a complete brake mechanism at each wheel. The brake shoes have brake linings on their outer surfaces. Each brake shoe is linked at one end by an anchor pin, the other end is operated by some means so that the brake shoe expands outwards the brake linings come into contact with the drum. Retracting spring keeps the brake shoes into position when the brakes are not applied. The drum encloses the entire mechanism to keep out dust and moisture. The braking plate completes the brake enclosure, holds the assembly to the car axle, and acts as the base for fastening the brake shoes and operating mechanism. When the brake pedal is pressed, the cam turns by means of brake linkage. When the cam turns, the shoes expand outwards against the drum. A toggle lever is also used for the same purpose. The brake rubs against the drum and thus stops its motion.

TYPES OF MECHANICAL ACTUATION BRAKES:

There are in general two main classes of mechanical actuating drum brake systems. One is the internal expanding drum brake and the other is the external contracting drum brake.

1. INTERNAL EXPANDING DRUM BRAKE: This type of brake is used in most modern motor vehicles. It is formed by mounting the shoes to rub or slide against the inside surface of the drum.

2) To safeguard the occupants from road shocks.

4 10 sI BRAKE SHOES:

Internal Expanding Brake

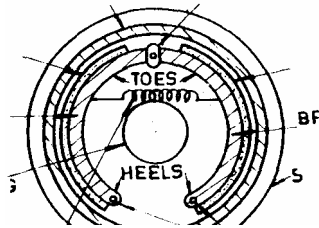

The system consists of brake drum, stationary plate, two shoes hinged at the anchor pins, cam system to expand the shoes and a retracting spring. Brake linings are fixed at the out sides of the shoes, For operation when the cam, is turned, the shoes with brake linings are forced against the drum. The brake linings create friction between the rotating drum and the expanding shoes. Thus the force of friction opposes the direction of drum rotation, there by stopping or slowing down the vehicle. When the brake is released the retracting or returning spring brings the shoes back to the off-position.

EXTERNAL CONTRACTING DRUM BRAKE:

This type of brake is only used as a parking in the motor vehicle. The system consists of drum, band with lining, operating lever with adjusting lever and push rod with returning spring. For operation when the push rod is operated by the hand or foot operated lever, then the lined brake band fitted around the drum is tightened to lock or slow down the rotating drum When the brake is released the return spring brings the band back to the off position.

This system to atmosphere therefore the dirt is thrown between the rubbing surfaces which reduces the braking efficiency. It has greater wear and tear so found unsatisfactory for running brakes

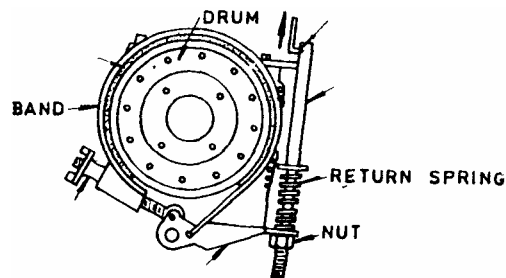

2) To safe gaurd the occupants from road shocks.

4 10 .sI BRAKE SHOES:
BRAKE SHOES:

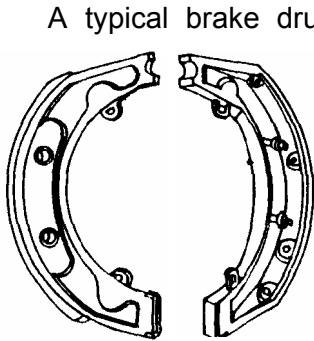

A typical brake drum is shown in Fig. Brake drums are thin cylindrical members made of cast iron; cast iron and steel ; steel and chrome . Nickel iron They- have a composite and centrifugal construction. In order to admit the brake shoes, their inside ends are opened while the out side ends are closed. 'The outer

brake Drum most portion of the brake drums include a cast iron liner with a steel back. In this case, the steel provides the strength while the cast iron inner surface liner having a high co-efficient of friction dissipates the heat more rapidly.

In certain front wheel brakes, a cast aluminium alloy drum with a cast iron liner is also used. The diameter of the brake drums usually range between 200 mm and 375 mm. The diameters of the circles made by the out side. of the shoe-linings are generally kept smaller than their inside diameters from 0. 25 . 0. 6 mm. In order to ir'creast. dissipation of heat, ribs or fins are also provided on the out side of the braking surfaces.

2) To safe gaurd the occupants from road shocks.

4 10 sI BRAKE SHOES:

Wheel brakes usually contain two shoes - a primary shoe on the left and a secondary shoe on the right provided as shown in Fig. These shoes are usually welded or riveted to the outside or bearing surface or semi-circular segments of steel provided with specially treated asbestos lining or made of heat and wear resisting friction materials. The brake linings provided may be molded type lining on both shoes or even brake lining on the primary shoe and molded brake lining on the secondary shoe. The linings are usually 28 to 63 mm wide and from 4 to 10 mm thick in case of passenger motor vehicles.

SERVO OR SELF ENERGISING ACTION OF BRAKE SHOES:

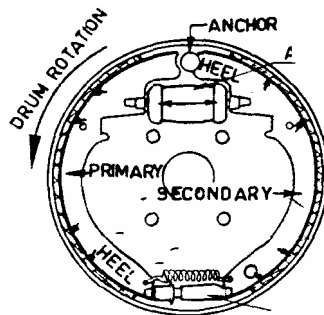

These are of drum type known as self-energizing drum brakes.

These are modern type of hydraulic wheel brakes of drum type. They have a special feature known as self-energizing or servo feature. To increase the brake pressure, the force of rotating drum is utilized fully because the drum is rotating in a counter clock wise direction (Fig 4.34) when the vehicle is traveling forward. More over the primary shoe is provided at the left tends to move in the direction of rotating drum due to its friction when the brakes are applied. Now the primary shoe is linked to the secondary shoe at the bottom while the secondary shoe is forced around against the anchor pin at the top. Due to this wrapping action, both the shoes are forced into tighter contact with the drum to cause the braking pressure to be applied more uniformly.

Fig. 4.36 Hydraulic Brake System

4 10 sI BRAKE SHOES:

The secondary shoe will tend to move in a clock wise direction against the primary shoe which is forced against the anchor pin. This usually happens when the brakes are applied as the car is in reverse.

HYDRAULIC BRAKING SYSTEM:

The hydraulic brakes are applied by the liquid pressure. The pedal force is transmitted to the brake shoe by means of a confined liquid through a system of force transmission. The force applied to the pedal is multiplied and transmitted to all the brake shoes by a force transmission system. This system is based upon Pascal's principle, which states that the confined liquids transmit pressure without loss equally in all directions.

The hydraulic brake system as shown in Fig. 4.3E essentially consists of two main components master cylinder and wheel cylinders. The master cylinder is connected by tubing to the wheel cylinders at each of the four wheels. The system is filled with the liquid under light pressure when the brakes are not in operation. The liquid is known as brake fluid: and is usually a mixture of glycerin and alcohol or Castor oil or denatured alcohol and some additives.

Each wheel brake consists of a cylinder brake drum which is mounted on the inner side of the wheel and revolves with it and two brake shoes which are mounted inside the brake drums and do not rotate. The shoes are fitted with a heat and wear resisting brake lining on their surfaces.

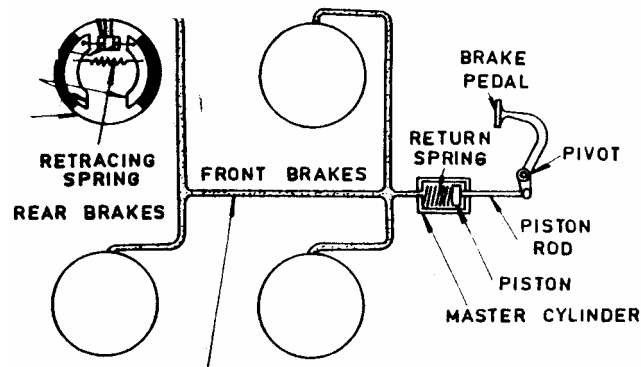

The brake pedal is connected to the master cylinder piston by means of a piston rod. When the brakes are to be applied, the driver depresses the pedal, the piston is forced into the master cylinder, this increasing the pressure of the fluid in the master cylinder and in the entire hydraulic system. This pressure is conducted instantaneously to the wheel cylinders,

'Fig. 4.36 Hydraulic Brake System

4 10 sI BRAKE SHOES:

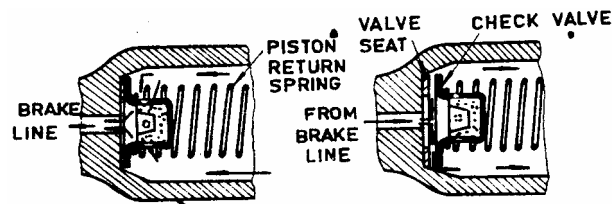
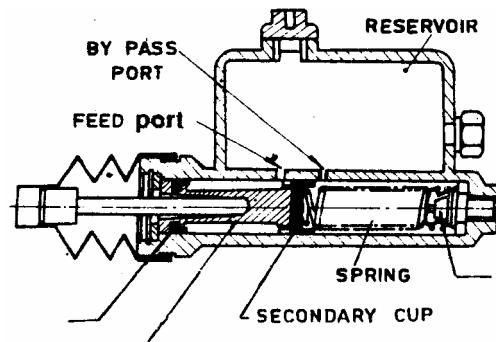

on each of the four brakes, where it forces the wheel cylinder pistons outwards. These pistons, in turn, force the brake shoes out against the brake drums. Thus the brakes are applied.

When the driver releases the brake pedal, the master cylinder piston returns to its original position due to the return spring pressure, and thus the fluid pressure in the entire system drops to its original low value, which allows retracting springs on wheel brakes to pull the brake shoes out of contact with the brake drums into their original positions. This causes the wheel cylinder pistons also to come back to their original inward positions. Thus, the brakes are released.

MASTER CYLINDER:

The master cylinder is the heart of the hydraulic brake system. It consists (Fig.4.361) of two main chambers: the fluid reservoir which contains the fluid to supply to the brake system and the compression chamber in which the piston operates. The reservoir supplies fluid to the brake system through 2 ports. The larger port is called the feed or intake,

'Fig. 4.36 Hydraulic Brake System

4 10 .sI BRAKE SHOES:

port and is connected to the portion of the piston between the primary and secondary cups which act as piston seats. The smaller port is called the relief, by pass or compensating port which connects the reservoir directly with the cylinder and lines when the piston is in the release position. The reservoir is vented to the atmosphere so that the atmospheric pressure causes the flow through the filler port. The vent is placed in the filler cap. The boot covers the push rod and the end of the cylinder to keep it free from foreign matter.

When the brake pedal is pressed the master cylinder piston moves forward to force the liquid under pressure (Fig. 4.36 a) into the system. The relief port is sealed out of the system. The liquid pressure is conducted to the wheel cylinders, where it forces the wheel cylinder pistons outward. These pistons force the brake shoes out against the brake drums.

4 10 sI BRAKE SHOES:

When the brake pedal is released, the return spring quickly forces the master cylinder piston back against the piston stop. Because the fluid in the lines returns (Fig~ 366) rather slowly, a vacuum tends to form in the cylinder in front of the piston. This causes the primary cup to collapse to allow the liquid to flow from the reservoir through the filler port; pass the piston to fill the vacuum. When the pedal is in 'off' position, the liquid may flow from the reservoir through the relief port in the master cylinder, supply lines, and Wheel cylinders to make up for any fluid that may be lost or to compensate for shrinkage cooling of the liquid. In this way a complete column of liquid is always maintained between the master cylinder piston rod wheel cylinder pistons.

WHEEL CYLINDER:

Wheel cylinder is the second impgrtant component of thu hydraulic bral~e system. A typical wheel cylinder shown in Fig 4.37~consists of two pistons which can move in opposite directions by the fulid pressure. It is rigidly mounted on the brake shield or backing plate. The boots protect the cylindars from foreign substances Bleeder valves are provided in the cylinder to permit air and liquid to be pumped out of the system during th~l\$eeding operation.

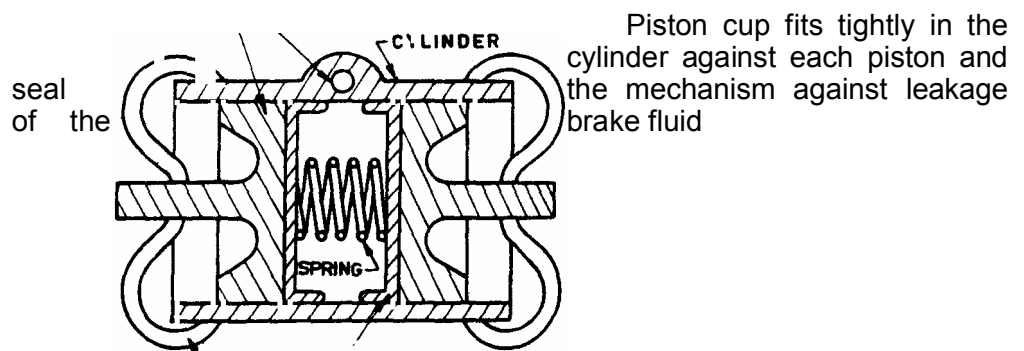

'Fig. 4.36 Hy&aulic Brake System

4.8.2. CAM AND TWIN LEVER STEERING GEAR BOX:

A spring serves to hold the cups against the piston when the pressure is decreased. When the brakes are applied, the brake fluid enters the

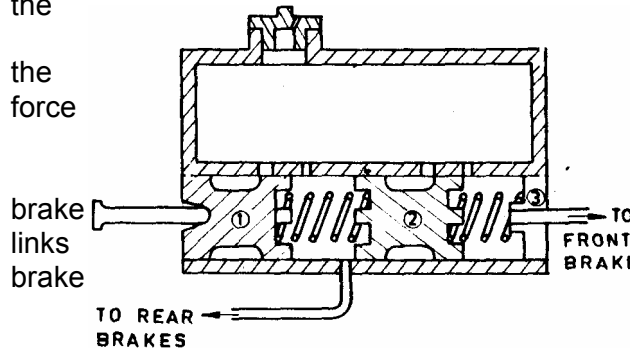

the cylinder from ~ brake line connection inlet between two pistons, It causes out the two pistons in opposite directions. This motion is transmitted to the shoes directly or torchlight and force them against the drum, thus applying the brake.

The copper-coated, tin-plated annealed steel tubing and flexible hose are used to connect the master cylinder and the wheel cylinders. The hoses are used to connect the lines to the front wheel cylinders to permit the front wheel to be turned. Rear wheel cylinders are generally connected directly to a line fastened to the rear-axle housing. The ,brake lines are attached directly or by means of brackets to the frame or axle housings.

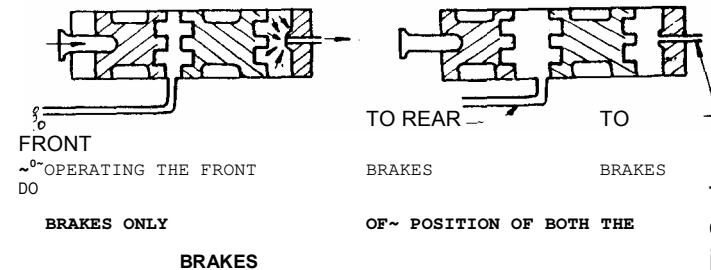

5. 3.TANDEM MASTER CYLINDER

FRONT
~^oOPERATING THE FRONT
DO
BRAKES ONLY
BRAKES

TO REAR
BRAKES

TO
BRAKES

OF~ POSITION OF BOTH THE
BRAKES

When due to fracture in the pipe line or due to leakage at joints the hydraulic brakes fail which may

be the cause of a serious accident of the vehicle. There fore to over come this difficulty and to provide safety against the accidents the master cylinder is designed in such a manner so that the separate lines go to rear and front brakes. The lines are so arranged that if one pair of the brake failed, the other will be still effective. A master cylinder designed on these base is called Tandem Master Cylinder. Fig. 4.38 shows the construction and working principle of a Tandem Master cylinder.

Under ordinary conditions the brake fluid will transmit pressure both to front as well as to the rear brakes, when the brake pedal is applied. How ever, when the front brake lines are damaged, piston (2) will move till it comes up against stop (3). After this pressure will start building up in space

'Fig. 4.36 Hy&aulic Brake System

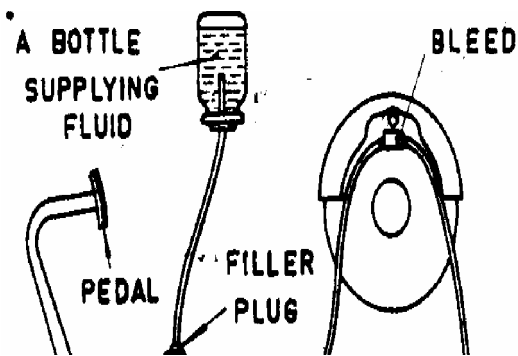

CAM AND TWIN LEVER STEERING GEAR BOX:

between piston (1) and (2) and rear brakes will be applied. Similarly when the rear brake lines are damaged no pressure will build up in space between pistons (1) and (2). So piston (1) will move freely till it comes up against (2). Further push at the brake pedal will move both pistons (1) and (2) together thereby applying the front brakes.

BLEEDING OF HYDRAULIC BRAKES:

In hydraulic brakes the air enters into the system through the joints or when the fluid level has become low. Air being compressible, the effort of brake pedal goes waste in applying brake. Until and unless air from the system is removed, the brakes could not function properly. The

Bleeding of The Hvd Brake System

The construction and procedure of bleeding shown in Fig. 4.39 is as follows: The bleed pipe is connected with the bleeder valve. The end of this bleeder pipe is kept dipped in a bottle containing the fluid. There is another bottle which is connected to the master cylinder filler plug by means of a pipe. This fluid enters the master cylinder through the bleeder valve and bleeder pipe. Finally it goes to the bottle which is connected to the bleeder pipe.

When the pedal is pressed from time to time, the air travels along with the liquid through the bleeder pipe and to the bleeding bottle. The air escapes in the form of bubbles for sometime. After the pedal has been pressed for a few times, a stage will come when only oil and no air will enter. At this time close the bleeder valve and remove the bleeder pipe. Also, remove the bottle with its cap at the filler plug of the master cylinder. The whole system is now free from air. This is the procedure of bleeding the hydraulic brakes.

'Fig. 4.36 Hydraulic Brake System

UNIT-III

ENGINE AUXILIARY SYSTEMS

FUEL FEED SYSTEM

REQUIREMENT OF AN IDEAL PETROL ENGINE FUEL:

Generally gasoline is used as a fuel in most of the petrol engine (S. I. engine). It is a mixture of many refinery products containing paraffins, naphthenes and aromatics in different ratios. The ratio depends upon the desired quality of the fuel. The important qualities of this fuel are as given under.

1. Antinock quality
2. Volatility
3. Gum deposits
4. Sulphur content

1. ANTIKNOCK QUALITY:

Sometimes the last part of the compressed air fuel mixture explodes thereby producing a sudden and sharp pressure increase the knocking noise and produces a hard hammer blow on the piston. Therefore gasoline produces always tend to minimize the knocking tendencies of fuel.

2. VOLATILITY:

The quality with which a liquid vaporizes easily is called volatility. When a liquid vaporizes at relatively low temperature then it is called high volatile. If it vaporizes at a higher temperature its volatility is low. The most important aspects of volatility are as given under:

- a) Easy starting
- b) Freedom from vapour lock
- c) Quick warming
- d) Smooth acceleration
- e) Good economy
- f) Freedom from crank case dilution
- g) The volatility blend.

3. GUM DEPOSITS:

Sometimes unsaturated hydrocarbons blended in the gasoline which acidize during storage and form a product known as gum. The gum is undesirable in the fuel. Because it deposits in carburetor, on intake valves, piston rings and other parts of the engine thereby restricting the regular supply of the fuel. Therefore, a good fuel must be of such a quality that neither it as gum content nor form gum during storage.

4. SULPHUR CONTENT:

It is an undesirable content in the gasoline. Because it tends to form corrosive compound which attacks various parts and thereby injuring the engine. Therefore, a fuel should contain a very limited or permissible quantity of sulphur in it.

2.1.1. OCTANE RATING:

Some fuel are more knock producing than others. The knocking tendencies are a I ways undesirable characteristics in an engine. Therefore chemicals are the fuel to reduce them. Thus, the Octane number rating in this is an expression which indicate the ability of a fuel to resist knock in an engine which is termed as Octane number. as well as clean fuel from the fuel tank. It can be conveniently used for the whole process of supplying continuously to the engine a suitable mixture of fuel vapour and air. It is not through any other means that the necessary air for complete combustion according to the chemical composition of the fuel can be supplied. Under all operating conditions, individual engine cylinders are supplied with correct proportions and quantities of fuel and air by this system. Different mixtures of fuel and air are required for performing different types of operations for meeting a wide range of speeds, loads and temperature conditions. Relatively rich mixture is required by the engine while accelerating or running at, high speed or pulling hard up hill. A linear mixture is sufficient while running on the level roads with a partly opened throttle since full power is not required under this condition. The carburetor is the device which meters, atomizes and as distributes the fuel through the air. It automatically adjusts both the amount and proportion of fuel and air to suit the operating conditions.

2 4 CARBURETTOR

The carburetor is a device for atomizing and vaporizing the fuel and mixing it with the air in varying proportions to suit the changing conditions of spark ignition engines. The air fuel mixture so obtained from the carburetor is called the combustible mixture.

The main functions of a carburetor are as given under.

- i) It preserves fuel at a constant head.
- ii) It vaporizes and atomizes the fuel and mixes it with the air. Vaporization means the change of fuel from a liquid to a vapour where as 'atomization' is the breaking up of fuel by mechanical system, so that every small particle of the fuel is surrounded by air.
- iii) It provides and controls the amount and strength of air-fuel mixture under varying conditions of load and speed of the engine.
- iv) It provides easy starting with the engine in cold
- v) It ensures the engine to run slowly without missing and without undue wastage of fuel,
- vi) It provides maximum acceleration without hesitation to pick up speed when the throttle is suddenly or slowly opened.

2.4. 2. CLASSIFICATION OF CARBURETTOR:

1. According to the arrangement of float chamber
 - (a) Eccentric
 - (b) Concentric
2. According to the direction air flow
 - (a) Down draft
 - (b) Side draft
 - (c) Up draft
 - (d) Semi-down draft.
3. According to the number of units
 - (a) Simple
 - (b) Dual
 - (c) Four—barrel.
4. According to the type of metering system
 - (a) Air bleed jet
 - (b) Metering rod type
5. According to the type of venturi
 - (a) Plain venturi
 - (b) Double venturi
 - (d) Nozzle bar venturi .
6. According to the pressure above the fuel in the float chamber.
 - (a) Unbalanced
 - (b) Balanced.

7. According to the type of power system.
 - (a) Manually operated (b) Vacuum controlled.
8. According to the method of varying mixture strength
 - (a) Constant choke carburetor (b) Constant vacuum carburetor.

2.5. SIMPLE CARBURETTOR:

A simple carburettor shown in Fig. 24. Consists of the round cylinder with constricted section of a fuel nozzle, a throttle valve and a float chamber. The round cylinder is called air horn and the constricted section is the venturi.

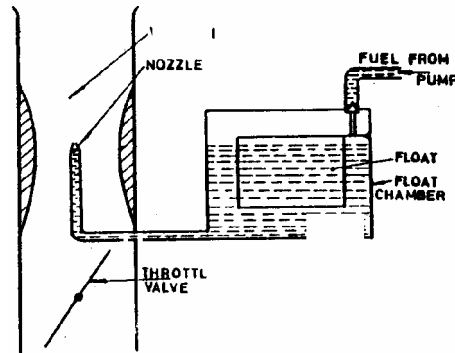

The venturi and float chamber are connected by the fuel nozzle. The throttle valve can be tilted to open or close the air horn. The construction and function of each part of the carburetor are as follows:

VENTURI:

A venturi is a narrow space in the cylindrical air horn, through which the air passes. As the same amount of air must pass through every point in the air horn, its velocity will be the greatest at the narrowest point. The more this area is reduced, the greater will be the velocity of air. The opening of the discharge jet is usually located just below the narrowest section of the venturi so that the mixture is most uniform.

The spray of gasoline from the nozzle and the air entering through the venturi are mixed together in the mixing chamber which is just below the discharge jet. In this chamber, the vaporization and atomization of the gasoline take place and it mixes with the air, so that the combustible mixture is produced. This mixture passes through the intake manifold into the cylinder.

THROTTLE VALVE: Fig. 2. 4 Simple Carburetor

The throttle valve is a circular disc, it is located in the mixing chamber of the air horn. It can be tilted to proportions of air fuel mixture at different speeds. Different methods for providing compensation are:

- (1) air valve regulation
- (2) compensating jet
- (3) air bleed compensation.
- (4) Multi jet compensation
- (5) Suction compensation.

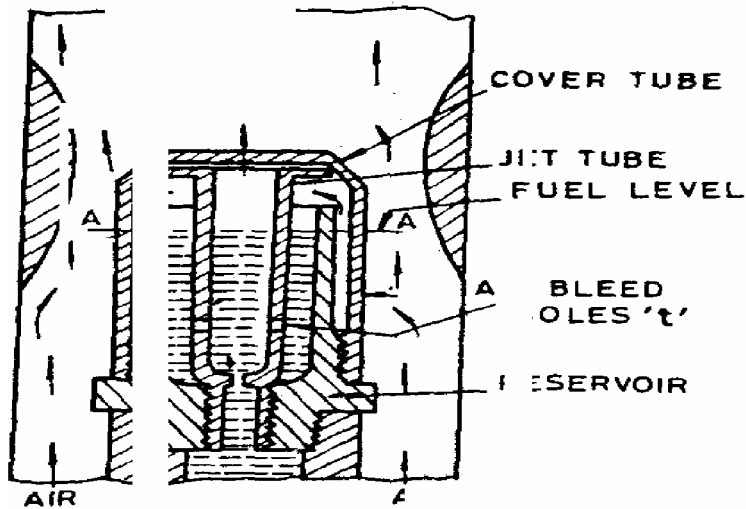

2. 6. 1. AIR BLEED COMPENSATION:

shows the detailed construction of a carburettor nozzle with provision of air bleed compensation. The jet tube is provided bleed holes around its periphery. The jet tube is fixed in a reservoir and assembly is covered by another inverted tube. The reservoir is open to the atmosphere by means

holes provided in the tube. When engine is not running then fuel will maintain level A-A. In the beginning the engine needs a richer mixture and after starting a weaker mixture. Air Bleed Compensation. When engine is started then due to suction the nozzle tip supplies a sufficient quantity of fuel to start it. As the engine speed is increased more suction is developed & the nozzle tip becomes empty thus allowing the air run through the holes of and air bleed holes into the jet tube. Thus diverts part of the air suction through the jet tube and decreases the flow of the fuel. In this way with the help of air bleed compensation a desired quantity of fuel is supplied by the nozzle for a different speed of the engine.

6. 2. VARIABLE JET OR COMPENSATING JET

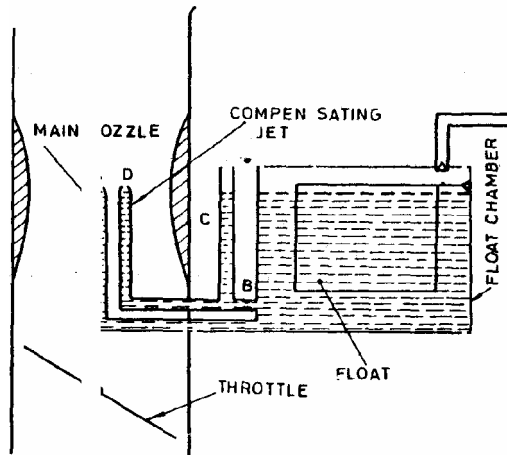

In a carburettor in addition to main nozzle, when an extra fuel supply nozzle restricted by an orifice is provided, then this circuit of fuel is known as compensating jet system. Refer Fig A is the main nozzle and B is the submerged or compensating jet. is the well which is open

to atmosphere When the engine is not running the fuel level in the main nozzle compensating nozzle and the well C will be available at the same level as in the float chamber. The main nozzle is connected directly to float chamber and it will supply richer mixture at larger throttle openings. But the case is different of the submerged Compensating Jet. When the engine is just started and the throttle valve is open a bit, small engine suction is applied, which draws fuel from the well C through delivery tube D, till the well C becomes empty. Further opening the throttle, therefore, does not increase the fuel flow through the compensating jet; it remains constant. However, the air flow is nevertheless increasing. As a result the higher speeds result in weaker mixtures through the compensating jet. The result is shown in In this way a uniform mixture of constant

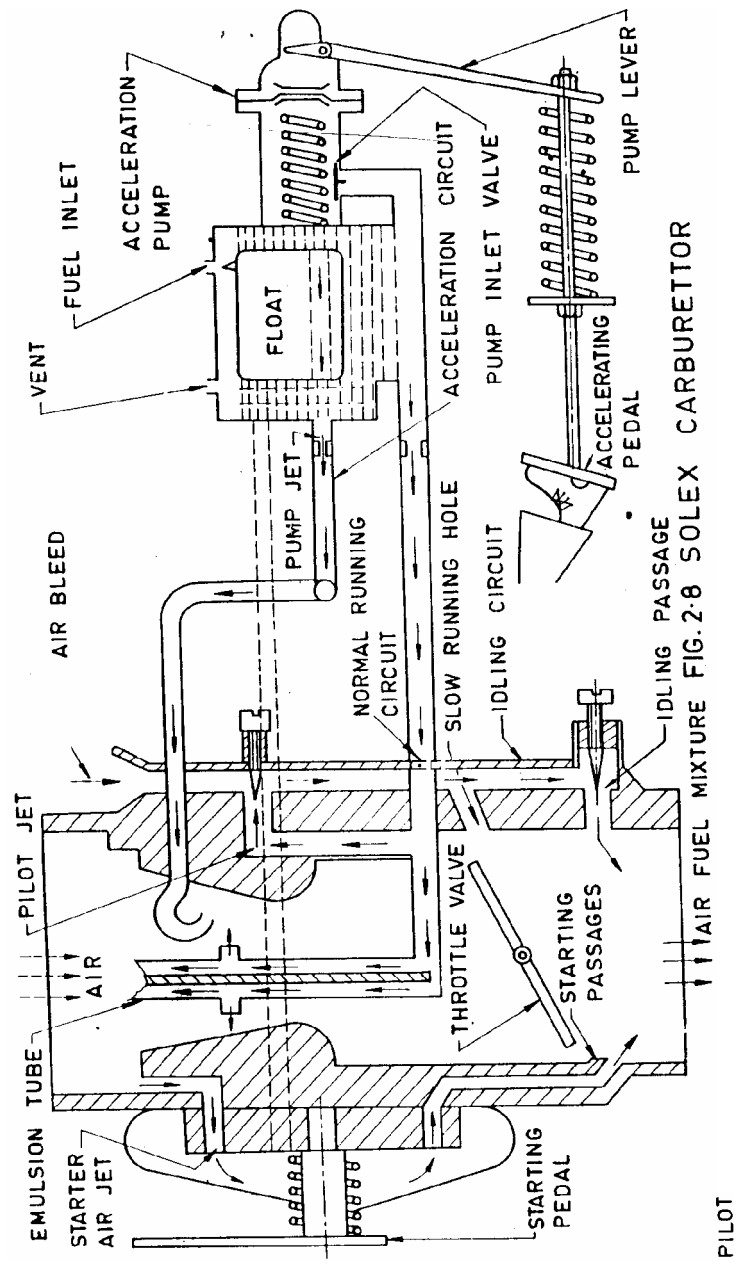

PILOT

FIG.2.8 SOLEX CARBURETTOR

2.9 DIESEL FUEL FEED SYSTEM:

The diesel fuel feed system ensures that the diesel oil is injected into the cylinders at the correct time. It consists of a diesel tank, feed pump, filter, injection pump, injector and connecting lines FIG.2. 17 shows the fuel feed system for a four cylinder diesel engine. The diesel fuel is first sucked by the feed pump. This is forced through

filter to injection pump. The filter filters all the minute dirt particles. When the pressure in the filter increases, a certain amount of fuel is released. This released fuel returns

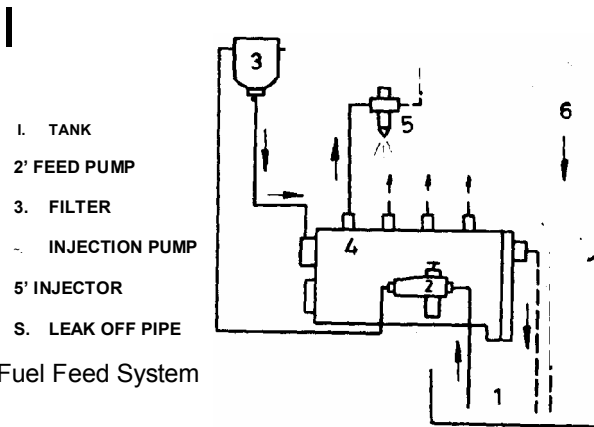

FIG.2.17 Diesel Fuel Feed System

to the tank. The injection pump gets the fuel from the feed pump. In injection pump there are plungers. By the operation of plunger the fuel reaches the injector. The fuel is 'Sprayed' through the injector into cylinder. A certain amount of fuel which is not injected returns to the tank.

2.9.1 FUEL INJECTOR:

The purpose of the fuel injector is to inject a small volume of fuel in a fine spray and, to assist in bringing each droplet into contact with a sufficient oxygen to give quick and complete combustion.

FIG.2.18 shows a fuel injector. It consists of a needle valve which is pressed on its seat in the nozzle by a plunger or spindle. A compression spring controls the pressure upon the plunger by which the needle opens.

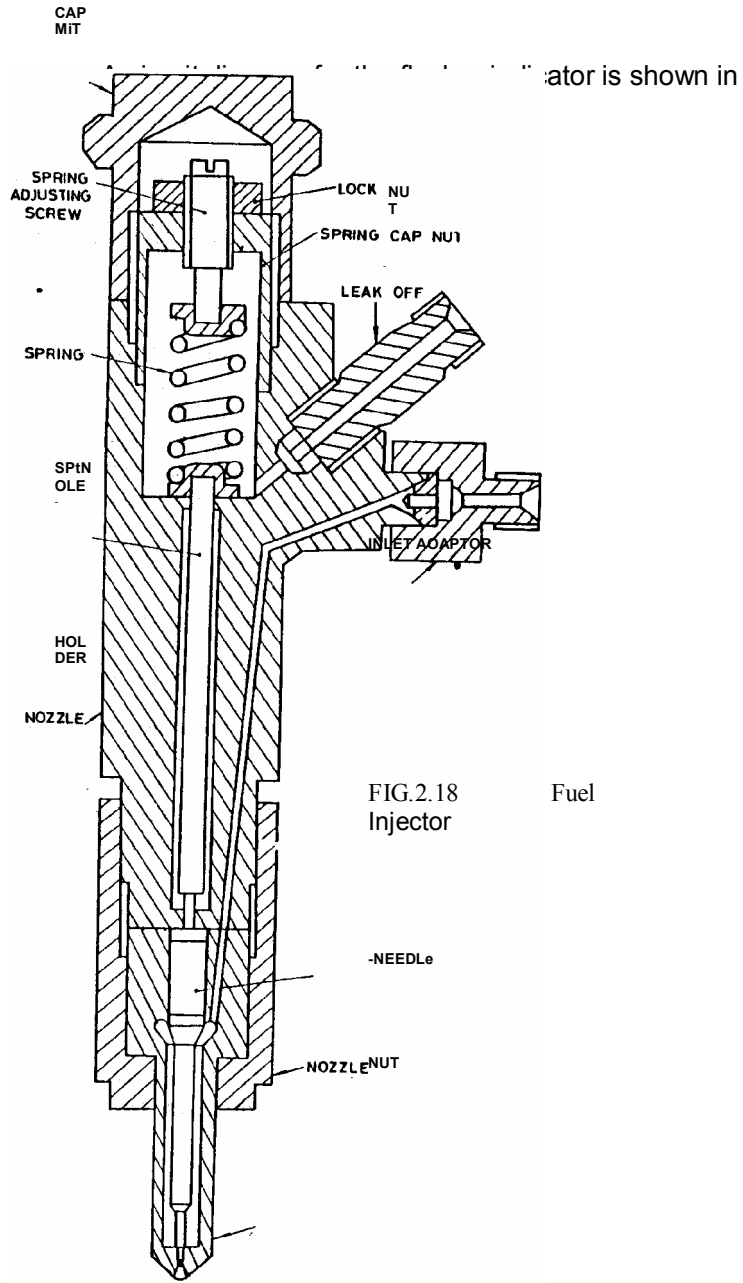

A circuit diagram for the flasher indicator is shown in nozzle is attached to the body of the injector by capnut. The fuel enters the nozzle through drillings in the injector body. The fuel may pass from a gallery down the sides of the lower parts of the needle valve, or it may through an annular groove in the nozzle and pass through drillings to a point just above the nozzle seat. The body of the nozzle holder provides access for the fuel and an outlet for the fuel that leaks into the area occupied by the spring.

When the needle valve is raised from its seat by the pressure of the fuel acting on the conical or stepped face of the valve, the injection of the fuel takes place. When the injection pressure falls below the spring pressure, the valve closes. This action tends to setup an oscillation of the valve during each injection and consequently breaks the fuels into small particles. Fuel leakage past the needle valve stem enters the upper part of the injector and is returned to the pump suction chamber or to the fuel tank. Fuel leakage provides lubrication for the valve stem.

2.9.2 TYPES OF FUEL INJECTION NOZZLES:

For adequate mixing of fuel particles with sufficient air for complete combustion of the fuel it is necessary that the correct shape of spray suitable to the combustion chamber as well as proper penetration of the air charge should be provided. There are in general four types of nozzles used in injection.

- (1) Single hole
- (2) Multihole
- (3) Pintle type
- (4) Pintux type

For adequate mixing of fuel particles with sufficient air for complete combustion of the fuel it is necessary that the correct shape of spray suitable to the combustion chamber as well as proper penetration of the air charge should be provided. There are in general four types of nozzles used in injection.

- (1) Single hole
- (2) Multihole
- (3) Pintle type
- (4) Pintux type

SINGLE HOLE:

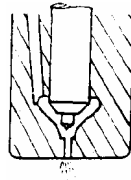

A single hole nozzle FIG2.19a has one hole at centre. The fuel is sprayed through this nozzle.

MULTI-HOLE:

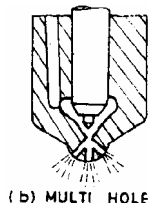

(b) MULTI HOLE

PINTLE NOZZLE

These nozzles have many holes arranged around the nozzle in a circle. The number, size, and angle of the holes may vary according to the engine. The nozzle FIG.2.19c provides a soft form of spray operating at a low injection pressure of 80-100

A circuit diagram for the flasher indicator is shown in atmosphere or 8-10 KN/Sq. met. This self clearing nozzle having a small cone extension at the end of the needle produces a conical spray pattern. As it leaves the injector, the

Nozzles

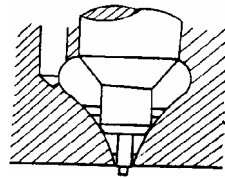

velocity of fuel increases. The emission of the conical spray between the needle pin and the orifice wall due to the pin on lower end of the needle being tapered inward, the spray cone in this type is generally kept at 60° angle.

PINTAUX NOZZLE:

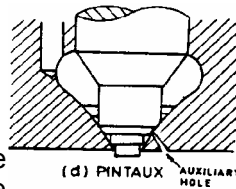

With normal design of the sprayed tangentially in to the spherical chamber, of the engine. In this way the fuel is not sprayed in to the hottest zone or towards the centre of the chamber. And for cold starting the engine needs heater plugs. Therefore to overcome the heating difficulty of the engine the nozzles are designed of pintaux type as shown in

At starting the nozzle valve is lifted slightly thus the pintle hole is not cleared and the fuel is only discharged through the auxiliary hole into the central hot zone there by obtaining better cold starting performance. When engine reaches to its normal speed then the needle valve is lifted from the pintle hole of the nozzle to pass the fuel through the pintle hole and entering the chamber tangentially. In this way this type of nozzle provides both the advantage of cold starting as well as of normal running of the engine.

FUEL INJECTION PUMP -

PLUNGER TYPE:

The purpose of the injection pump is to deliver the metered amount of fuel exactly at the correct moment to the spring loaded fuel injector. The delivery pressure of this pump is of 150 to 175 atmospheres, which is sufficient to open the spring loaded valve of the fuel injector. There by allowing the high pressure fuel to spray into the combustion chambers.

CONSTRUCTION:

The mechanism and the most important parts of the single element pump is shown in the figure. 2.20 It comprises a plunger and barrel; delivery valve and its seating; which are always kept together and the individual components of which are not interchangeable. The barrel consists of two inlet ports, through which the fuel enters from the gallery to the barrel. The plunger of the pump

A circuit diagram for the flasher indicator is shown in consists of a vertical channel extending from it upper edge to an annular groove, the top edge of which is cut in the form of a helix as shown in the figure. 2.20a

~ In recent designs a plunger consists of a cen:ral hole instead of the channel and a helical groove instead of helix and annualar groove. The lug or lower part of the plunger is engaged in the slot of the toothed sleeve. The rotary movement of the toothed sleeve with the plunger is con. trolled by means of sliding movement of the toothed rack,. A spring loaded delivery valve is fitted on its seating provided at the top of the pump barrel. Referring the fig. 2.20.b the force of the valve spring always presses the delivery valve on its seat. The delivery valve is guided through its stem in the valve holder.It acts as a one

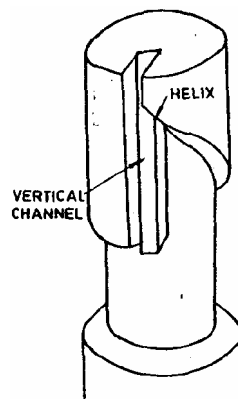

A circuit diagram for the flasher indicator is shown in

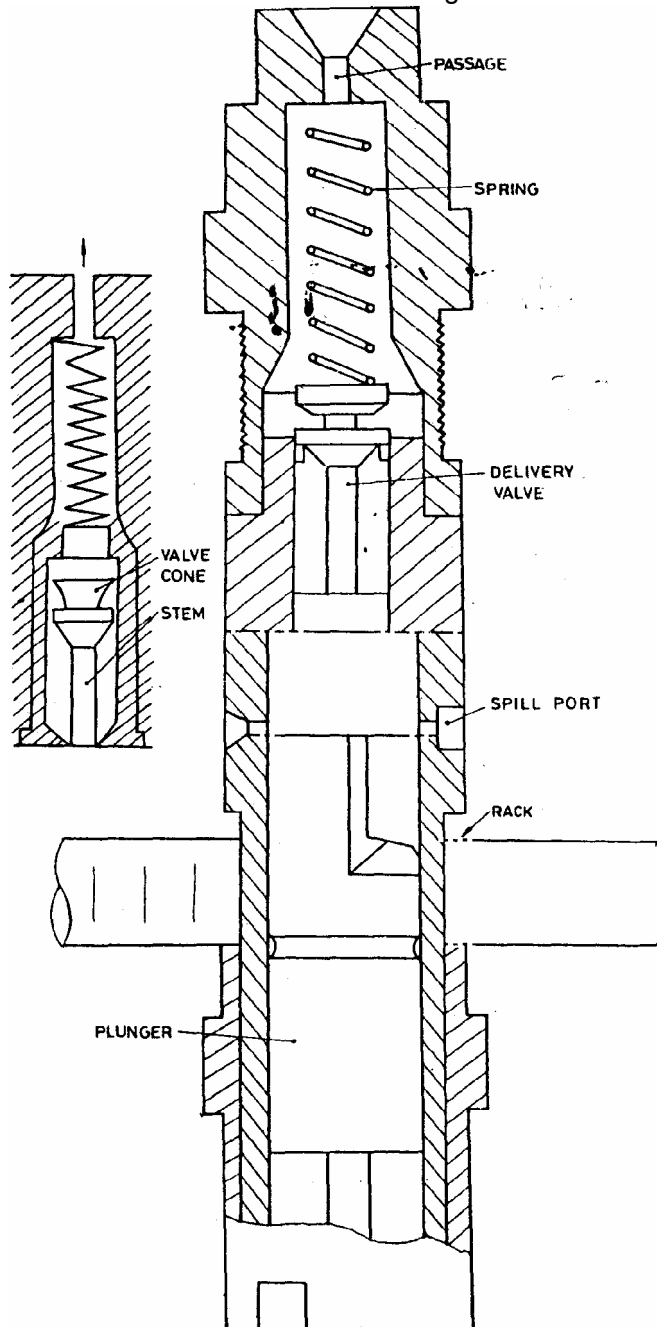

way valve and during the fuel delivery stroke it is lifted from its seat so that the fuel can flow along the longitudinal grooves and over the valve face into the delivery pipes

OPERATION:

For the working principle of the pump, say the plunger is at the bottom dead centre starting

A circuit diagram for the flasher indicator is shown in position. Under this position the two fuel inlet ports are uncovered from the sides of the plunger. As the plunger moves upwards the edge of it cuts-off the fuel supply. Now the space above the plunger is full of fuel. Further upward movement of plunger tends to lift the delivery valve against the pressure of its spring and hence entering the fuel through the pipe to the injector. This delivery of the fuel from injection pump remains continue till the helix of the plunger opens the port in the barrel, thus communicating the fuel above the plunger to the gallery, via the vertical slot and then cutting-off fuel delivery to the injector. The fuel delivery to the injector is increased or decreased by the rack and pinion mechanism. The movement of fuel cut-off by the plunger can be carried to any desired extent. Similarly if the plunger is rotated in such a way that vertical groove is opposite the right port, then there will be no pumping action because under this position the top of the plunger remains connected with the inlet port. This corresponds to the zero delivery and this position is called stop position of the pump.

FIG.2.20c shows how the rotation of the plunger affects the quantity of the fuel injected.

FIGURE A:

- (i) The plunger has been rotated into shut off position.
- (ii) The slot connecting the top of the plunger with the recess, is in line with the port.
- (iii) No fuel can be trapped and injected in this position

The starting motor or the cranking motor is direct current motor which cranks the engine for starting. Cranking the engine means to rotate the crank shaft by applying torque on it so that the piston may get reciprocating motion. The starting motor is mounted on the engine flywheel housing. It is series wound and designed to operate on large currents at low voltage. It must be capable of exerting a very high torque when starting and at low speeds. The armature and fields are built with thick wire to keep the resistance low and to enable them to carry large currents without overheating. The faster it turns, the less current it draws, the slower it turns, the more torque it develops. The starting motor voltage is generally 12 volt on passenger cars.

The operation of the motor is that when the current passes through the armature then it acts as an electromagnet produced in the motor fields. As soon as the armature is turned by half rotation the segments of the commutator change brush thereby changing the direction of the current flowing through the armature winding and reversing its polarity. This action forces the armature to rotate another half revolution. This process remains continue and thereby rotating the motor armature.

Certain forms of drive mechanism is usually provided at the end of the armature shaft. It helps the motor to start the engine. The starter drive is mainly concerned with the method of linking the starting motors to the engine flywheel for cranking the engine until it starts and disconnecting it automatically when the engine has started running. For this purpose a set of gears or a friction drive such as a gear reduction system is generally used to engage

engage the starting motor with the engine flywheel. To provide the most efficient working condition, gear reduction of the order of 15:1 is most suitable.

5-2.1 DIFFERENT TYPES OF STARTING MOTOR:

A circuit diagram for the flasher indicator is shown in

The starting motors use ^USLIDING PLUI-GER. either two pole winding or four pole winding.

TWO POLE WINDING For ^ILA, _A two pole field winding as shown in Fig 5.2. The current from the battery divides when it enters separate field winding from the commutator of the armature. The current in the armature that adjacent to the face field repulsive forces that turns the returns to the battery through

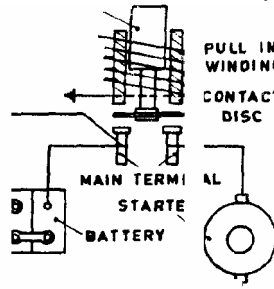

in light duty the motor~s are made with in Fig 5.2. The current from the the motor, each branch leading to fields the current is led to the through the two insulated brushes. creates simultaneously *four* poles poles to produce the attractive and armature. The armature current the *two* grounded brushes.

T, •R
-FIELD COIL
POLE SHOE

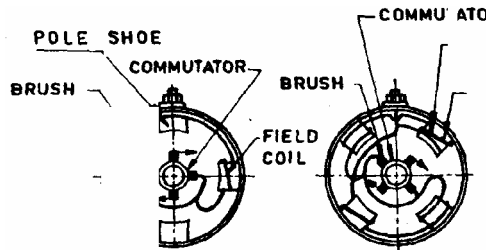

FOUR POLE FIELD WINDING: For large engines the starting motors are made with four—pole field winding as shown in Fig. 5.3. It is used in large engine in order to develop motor torque. It operates in the same manner as the two-winding type.

5.2.2 STARTING MOTOR SWITCHE: Different types switches used to connect the starting motor with the Two Pole

A circuit diagram for the flasher indicator is shown in

Solenoid Switch

A heavy duty foot operated switch was used in some early models. A magnetic switch, also known as solenoid switch or starter relay is used in many present day models. It consists of a plunger, contact disc, winding terminals and necessary connecting cables. The switch is connected between the starting motor and the battery. The current from the battery passes through the pull in winding to form a strong electromagnet; when the Switch is on and circuit is completed to ground. The electromagnet attracts the plunger against the spring, which causes the two terminals connected by the contact disc. This makes the circuit complete between the, battery and the starting motor.

When the switch is off, the circuit through the electromagnet winding is broken. The spring moves the Plunger and the disc back to open the connection between the battery and the starting motor.

The manual switch is operated by hand. When the Plunger is pressed, it makes contact between the two connect the battery from the starting motor.

3.2.3 STARTER MOTOR DRIVE MECHANISM:

The starting motor is linked to the engine flywheel through set of gears. A pinion gear is attached to the Starter armature which drives a ring gear attached to the flywheel. The arrangement is so made that the two gears engage to crank the engine until it starts and then disengage automatically

A circuit diagram for the flasher indicator is shown in

when the engine is running. The gear ratios about 15:1. The armature rotates 15 times to cause the flywheel to rotate once. Thus the cranking motor requires only one fifteenth as much power as would an electric motor directly coupled to the crank shaft. The armature may revolve at about 2000 to 3000 rpm when the cranking motor is operated and hence the flywheel will rotate as high as 200rpm.

When the engine starts, its speed may increase to about 3000 rpm. If the pinion is still in mesh with the fly wheel, it will revolve the armature at about 45000 rpm, which is very high speed. At this speed, the centrifugal force would cause the conductors and commutator segments to be thrown out to the armature damaging the motor. Hence the pinion must be disengaged from the flywheel, after the engine has started. The automatic engagement and disengagement of the motor with the engine flywheel and is obtained with the help of drive arrangement.

BENDIX DRIVE:

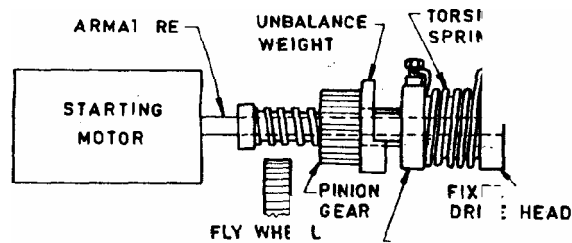

Bendix Drive

The bendix drive is shown in Fig 5.5. The drive head is keyed to the end of that armature shaft. The pinion gear, having internal threads, is mounted on the threaded sleeve, just like a nut on a bolt. The sleeve is not connected directly to the shaft of the starting motor but uses it only as a bearing. A spring is attached to the drive head and also to the sleeve. it is fastened to the armature shaft of the starting motor

A circuit diagram for the flasher indicator is shown in

When the starting motor is at rest, the pinion gear is not engaged with the flywheel. When the starting motor is switched on, the armature begins to rotate. This causes the sleeve to rotate also because the sleeve is fastened to the armature shaft through a spring. The pinion because of its inertia of rest and its unbalanced weight, turns very little, but it moves forward on the revolving bolt, until it engages with the teeth of the flywheel. The slight turning of the pinion gear helps to engage it properly with the flywheel. When the pinion gear strikes with the collar, it begins to turn the sleeve, causing the flywheel to turn with it. When the flywheel turns, the crank shaft also turns and the engine starts. The spring between the armature shaft and the threaded sleeve takes the shock of the start.

After the engine starts, the pinion gear is turned by the engine much faster than when rotated by the starting motor. This causes the pinion gear to turn back on the sleeve, making it disengaged with the flywheel,

2. FOLLO THRU DRIVE:

The folo-thru drive is very similar to the Bendix drive. The difference is the Folo-thru drive keeps the starting motor engaged with the flywheel until a predetermined engine speed is reached but in Bendix drive it is not so. In the Folo-thru drive, Fig 5.6 the threaded sleeve is attached to the armature shaft through a spiral spring. A pinion is mounted on the

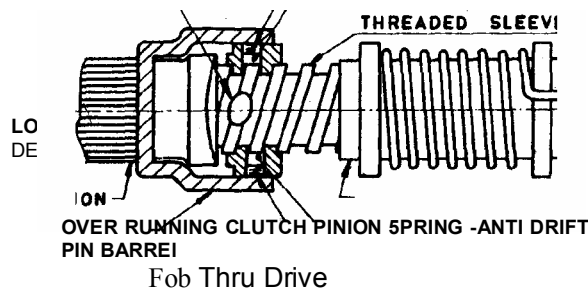

threaded sleeve. The pinion base has two small spring loaded pins, a lock pin and an anti drift pin. The anti drift pin is similar to the lock

A circuit diagram for the flasher indicator is shown in

stronger spring. The anti drift pin rides on the anti drift slope on the threaded sleeve and keeps the pinion from drifting into the ring gear, when the starter is not in use. It imposes a friction drag that holds the pinion in the disengaged position. The lock pin drops into a detent in the sleeve thread as the pinion moves out of the cranking position. This holds the pinion engaged with the fly wheel during cranking. It prevents the pinion from being disengaged by a false start, during which the engine might fire few times and then die. The pinion is thus held in engaged position, and cranking continues until the engine really gets started.

After the engine has started and the engine speed increases, the centrifugal force on the lock pin moves it out of detent, and the pinion disengages from the flywheel.

The overrunning clutch prevents the starting motor from being damaged, when the engine speed is greater than the starting motor speed. In this condition, the pinion, still engaged by the lock pin, overruns the threaded sleeve and ratchets over the clutch teeth. If the engine speed slows down the pinion automatically resumes driving the flywheel as soon as the speed of the overrunning parts decrease to the starting motor method. This intermediate operation will continue until the engine speed increases to disengage the pinion from the flywheel.

3 OVER RUNNING CLUTCH DRIVE:

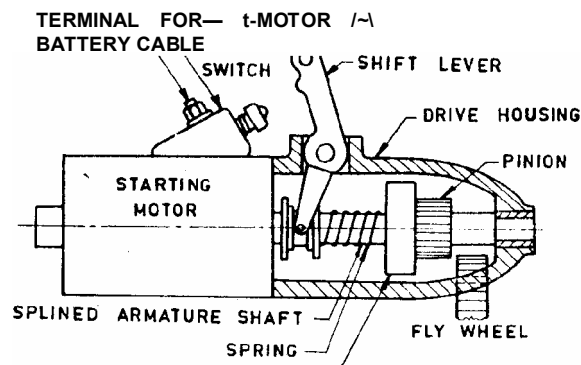

A circuit diagram for the flasher indicator is shown in

Fig Shows the overrunning clutch drive. The starter lever is linked to a starter pedal which extends into the driver's compartment and is operated by the foot pressure. When the starter pedal is pressed, the shift lever compresses the drive sleeves and spring which ultimately pushes to overrunning clutch and pinion gear assembly toward -the flywheel. The starter switch is closed by the shift lever when the starter pedal is fully pressed. As soon as the starter switch is closed, the pinion gear will turn and engage with the flywheel, thus starting the engine. When the engine starts, the over running clutch comes into action. The unit is so designed that, as the starting motor turns the pinion is driven through the over running clutch. But as soon as the engine starts the pinion turns much faster then the starting motor, due to which it slips back wards into the over running clutch. When the starting switch is opened, the engaging lever releases the pinion from the flywheel gear.

The over running clutch (Fig) consists of an outer shell and the pinion collar assembly. The outer shell has fair hardened steel rollers fitted into four notches. The notches are concentric, but are smaller in the end opposite to the plunger springs. When the clutch shell is turned by the armature shaft, the rollers are wedged in the notches to force the collar to turn with the shell. Since the collar drives the pinion gear, this action enables the armature to rotate the pinion cranking the engine.

After the engine starts, than the armature, so that larger sections of the This allows the penion to clutch. When the shift lever shift lever pulls pinion back

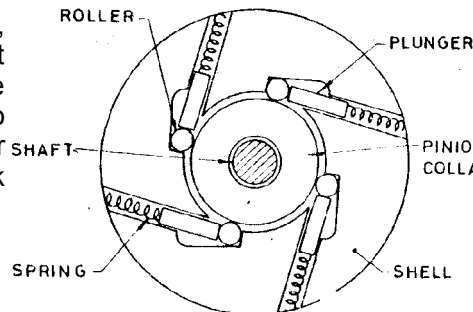

it turns the pinion gear faster the rollers are rotated into the notches, where they are free. over run thd remainder of the is released, a spring on the out of engagement.

Fig Over Running Clutch

4. SOLENOID SHIFT

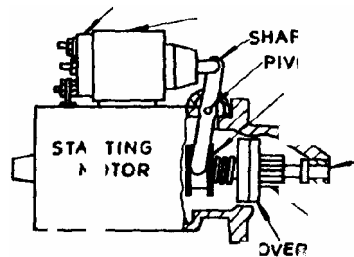

Fig.Solenoid Shift

In this system the starting motor consists of a solenoid unit provided with a soft iron plunger. When current is passed through the solenoid winding then it attracts the plunger thereby operating the shift lever thus to engage the pinion with the flywheel gear.

A circuit diagram for the flasher indicator is shown in

the moment of the plunger also operates the contact disc of the direct switch. the circuits of which are shown in Fig. 5.8 The solenoid unit is provided with two windings. a shunt and a series. When the starter switch is closed then the battery current flows to both the coils. Thus due to

electromagnetic force plunger is attracted to shift the pinion gear. As soon as the pinion is engaged the plunger pushes the contact disc thereby connecting the motor with the batteries Under this position of the disc, the battery current also passes through the series coil which is connected parallel to the terminals. When the engine is started the current following
IGNITION SYSTEM:

The spark ignition engines require some device to ignite the compressed air-fuel mixture inside the cylinder at the end of the compression stroke. Ignition system serves this purpose. It is a part of electrical system which carries the electrical current to spark plug which gives spark to ignite the air fuel mixture at the correct time. Some systems use transistors to reduce the load on the distributor contact points. Other systems use a combination of transistors and a magnetic pickup in the distributor. There are two types of ignition systems Used in petrol engines.

1. Battery ignition system (or coil ignition system)
2. Magneto ignition system.

Both the ignition systems are based on the principle of mutual electromagnetic induction. The battery ignition system is mostly used in passenger cars and light trucks. In the battery ignition system, the current in the primary winding is supplied by the battery whereas in magneto ignition system, the magneto produces and supplies current to the primary winding.

5. 6. 1, BATTERY COIL IGNITION SYSTEM:

Fig. 5.12 Battery Coil Ignition System

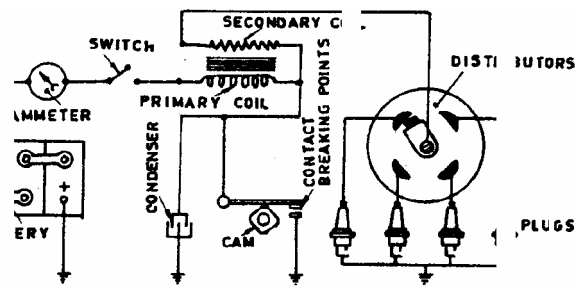

Fig. 6. 12 shows the ignition Systems. It consists of ammeter, switch, ignition coil, contact breaker, distributor and

battery coil
battery,
condenser,
sparkplug.

The primary ignition circuit starts at the battery and passes through the switch, ammeter, primary winding contact breaker points to the ground. A condenser is also connected in parallel to the contact breaker points. One end of the condenser is connected to the contact breaker arm and

A circuit diagram for the flasher indicator is shown in the end is surrounded. condary ignition circuit is not connected electrically to the primary ignition circuit. It starts from the ground and passes through the secondary winding, distributors, spark plug to the ground.

The ignition coil steps up 6 to 12 volts from the battery at the high tension volta9e of about 20000 to 30000 Volts required to jump the spark at the sparkplug gap, which ignites the combustible charge in the cylinder. The rotor of the distributor revolves and distributes the current to the four seg~ments which inturn, send it to the spark plugs. The purpose of the condenser is to reduce arcing at the breaker points and thereby prolong their life. Because the ignition system is four cylinder engine, the cam of the contact breaker has four lobes. It makes and breaks the contact of the primary .circuit four times in every revolution of the cam.

When the ignition switch is on, the current will flow from the battery through the primary winding. It produces magnetic field in the coil When the contact points open, the magnetic field collapses and the movement of the magnetic field induces current in the secondary winding coil. Because the secondary winding has many more turns of fine wire, the voltage increases unto 30000 volts. The primary winding consists of 200-300w turns of thick wire. About 1 5000 Volts are necessary to make the spark jump at 1 mm gap. The distributor then directs the high voltage to the proper spark plug when it jumps the gap, producing a spark which ignites the combustion mixture in the cylinder.

5.6. 2. FLY WHEEL MAGNETO OF TWO WHEELERS:

The magneto ignition system its own. It does not depend on any is used in motor cycles. It is also still as tractors and fire engines.

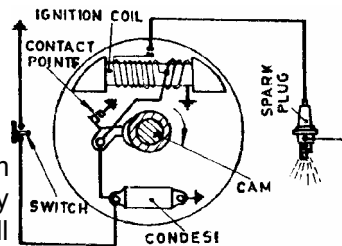

generates the ignition current on battery or generator, This system being used in a few vehicles such

A circuit diagram for the flasher indicator is shown in

Figure shows the fly wheel magneto of two wheelers. When the fly wheel is rotating, the cam also rotates. This cam breaks the contact points. There is a condenser, contact breaking points and an induction coil. The induction coil, contact breaking point and condenser do not rotate. The horse shoe magnet which is fitted with the fly wheel flywheel is also rotated. Magneto of Two Wheelers

5. 7. IGNITION COIL:

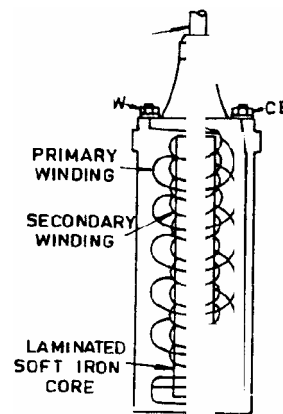

Fig Ignition Coil

The ignition coil is a transformer which steps up 6 to 12 volts of the battery to the 6,000 to 20,000 volts, thereby obtaining a spark at the electrodes of the plug.

Referring fig. 5. 14 the ignition coil consists of a metallic clad or case in which an iron core is placed. The inner cylindrical surface of the case is HIGH TENSION provided with a magnetic yoke. The coil consists of two windings the primary and the secondary. The primary winding contains about 200-300 turns of copper wire of about 20 SWG and the secondary winding contains about 15,000 to 20,000 turns of copper wire about 40 SWG. The winding wires are provided with a thin coat of enameled insulation.

First the secondary coil is wound over the core and then the primary winding is done over it. The two terminals of the primary winding are taken out from the case, one of which is connected to the battery and the other with the contact breaker arm as shown in the Fig. One end of the secondary winding is connected to the spark plug through the distributor while the other end is shorted by means of interconnection with the primary winding. The lower end of the iron core is

A circuit diagram for the flasher indicator is shown in installed in the porcelain base while the upper end is supported in a bakelite cap provided at the top of the case.

In primary circuit the contact breaker points are opened and closed by means of rotating cam provided in the distributor. When the ignition switch is on and the contact breaker points are closed then the current from battery flows through the primary winding and which builds up a magnetic field. When the breaker points are in open position and this magnetic field collapses, cuts across the secondary winding and induces a high voltage. The induction of the voltage depends upon the rate of collapse of the magnetic field as well as the ratio of secondary to primary turns on the coil windings. This high voltage when supplied to the spark plugs then it produces spark across them which ignites the fuel air mixture already compressed in the engine cylinder.

In order to illuminate the roads and highways sufficiently for safe night driving a lighting system is generally used in motor vehicles.

LIGHTING SYSTEM

As shown in Fig the circuit starts from battery.

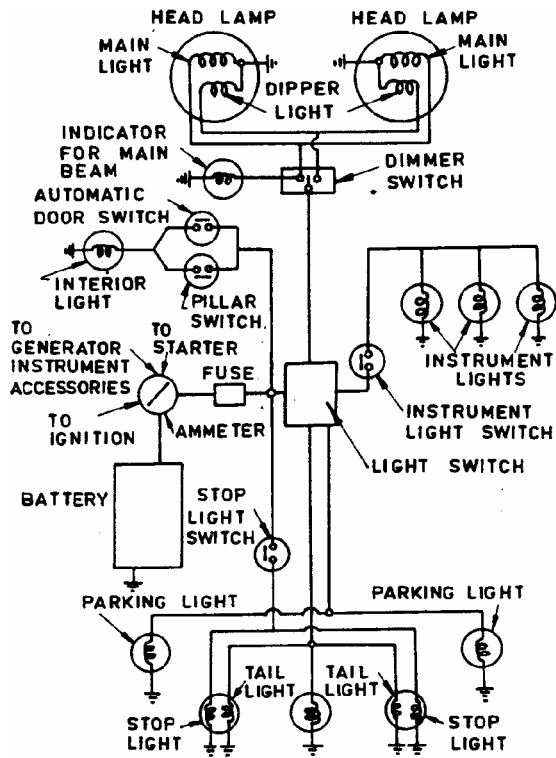

After passing through the ammeter or charge indicator and a fuse or circuit breaker it reaches the particular light switch. The brake system controls the stoplight circuit by stoplight switch which is closed when brakes are applied. The light switches provided on the instrument panel control all other lights. Three positions parking, head lamp and *off* positions are provided in this switch: The circuit to the parking lights, tail lights license plate light and instrument light is completed when this switch comes in the parking position. In the head lamp positions, the current is sent to all the head lamps, tail light, license plate light and instrument plate by the light switch. A foot operated dimmer switch which indicates whether the current goes to the upper or lower beam filaments is also provided in the head lamp circuit.

A circuit diagram for the flasher indicator is shown in

In order to protect those lights from over loads and short circuiting, a common fuse or circuit breaker or separate set off fuses for each individual light are provided~

DIRECTION INDICATING SYSTEM:

Directional signals are used in most cars to indicate the in which 'the driver intends to turn his car. The lighting circuit of directional signals is connected to that at Fig. of the parking lights in the front and rear of the car, so that the attention of the other drivers, coming from the front or rear is carefully attracted while the car has to take a turn. It actually prevents the accidents. The light of the directional signal flashes about 80 times per minute to attract the other drivers. The directional signals are attached on each side of the car and the flashing light is visible from both the front and rear sides.

The direction signal lights are operated either manually or automatically. The switch lever for operating the mechanism is located under the steering wheel or opposite to the gear shift lever, and is flipped down for left turns and up for right turn. The automatic turn off is accomplished by a mechanism that breaks the circuit when wheel turns to straight ahead position. The right and left pivot lamps on the instrument board in the form of arrows flash when the directional signals on the corresponding sides in operation.

FLASHER UNIT

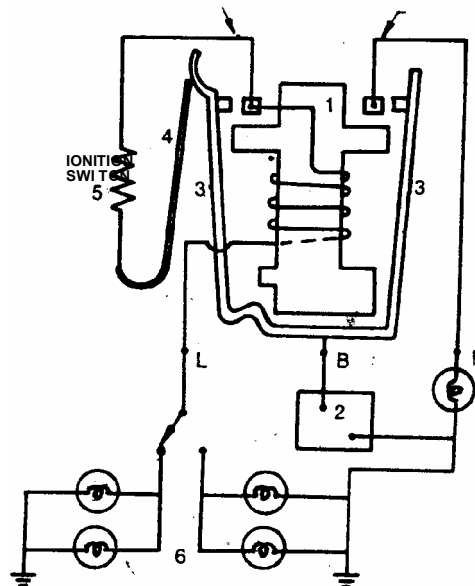

Fig In this there is an electromagnet coil winding. One main armature and contacts, and other secondary armature and pilot contacts. The actuating wire has a special property. ie its length increases when it is heated by a current and decreases when it cools down.

In the figure the current flows from the battery to terminal(B). norm this point the current flows to point (L) through blade, the left open contact, actuating wire, ballast resistor and fixed contact

Further it goes around the electromagnet coil winding and reaches point(L). From (L) the current flows to the two indicator lamps. (right or left) In this stage the reduced current flows in the cfrcuit. This reduced current is not sufficient to illuminate the lamps. When the current flows through the actuating wire it expands. There is a contact at the end of the left hand blade. This contact meets

A circuit diagram for the flasher indicator is shown in other fixed contact. This happens due to the attraction of the electromagnet pole piece. Now the actuating wire and ballast resistance cut out of the circuit. So full current flows from terminal (B) to terminal (L) along the closed contact round the coil winding. Thus the lamps get illuminated. When the actuating wire cools down, it breaks the contact. Full current is then cut out from lamp. Thus, the full current flow and much reduced flow take place alternately. This series causes the periodical flashes at flasher lamps.

FUEL GAUGES:

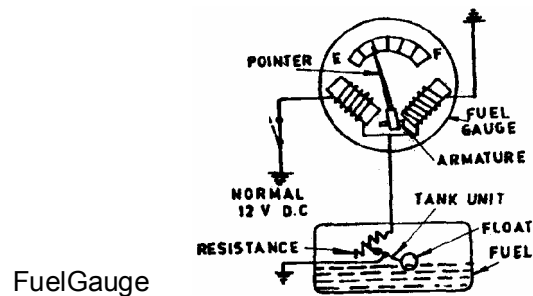

The fuel gauging system consists of a fuel gauge mounted on the dashboard and tank unit in the fuel tank, the circuit diagram being shown in Fig. The fuel gauge indicates the level of fuel in the tank according to the position of the tank unit float, a limited reserve of fuel being present in the tank when the gauge shows 'empty'. The hinged float rises and falls according to the level of the fuel, and moves a contact arm over a resistance coil. In this way the current flowing in the circuit is varied, and the variation is communicated to a meter mounted on the face of the meter being calibrated to indicate the quantity of fuel in the tank.

OIL PRESSURE GAUGE:

An oil pressure gauge mounted on the instrument panel of all cars equipped with pressure lubricating system to tell the driver what the oil pressure is in the engine. shows balancing coil type pressure gauge. It consists of two separate units: the engine unit and the indicating unit. The engine unit consists of a moving contact pressure gauge that moves over resistance according to the varying oil pressure against a diaphragm. As the pressure increases, the diaphragm moves inward which the contact moves along the resistance so that more resistance is placed in the circuit between the engine and indicating unit. This reduces the amount of current flowing in the circuit. The indicating unit consists of two coils that balance the movement of the pointer on a scale, in a manner similar to electrically operated fuel gauge.

5. 16. TEMPERATURE GAUGES:

To know the temperature of the engine while it is running, is an important consideration because a slight negligence may cause a serious engine accident. The engine temperature is indicated by means of a gauge mounted on the dash board of the driver's Cab. If the temperature goes too high than the driver at once stops the vehicles and gets the engine to be cooled.

shown electrically operated temperature gauge. It consists of two units, engine unit and

A circuit diagram for the flasher indicator is shown in dash unit. The dash unit consists of two coils, pointer, armature and a dial. The engine unit consists of a resistance which is effected with the variations of engine temperatures. Engine unit is connected to the coil A of dash unit with the help of a metallic wire. The coil B of the dash unit is connected through an ignition switch to battery. As the temperature of the engine increases, the value of the resistance decrease thereby flowing more current through the A, and increasing the e.m.f. built up there, Under this condition a magnetic pull towards coil A is developed on the armature. This action moves the pointer attached with the armature to show the higher temperature on the dial.

5. 17. WIRING CABLES:

In order to carry current to the various electrical units and components, cables are used. For easy identification, the cables having different colored covers should be used for different circuits particularly the cables emerging from a protective joint or junction box. Many simple circuits involve the component, its switch and three wires, feed, switch wire and return are considered to be included in the electric system of a motor vehicle. Generally feed wires as

UNIT-I

TRANSMISSION SYSTEM

CLUTCHES

TYPES OF FRICTION CLUTCHES:

The clutches used in motor vehicles are almost very similar in construction and operation. There are some differences in the details of the linkage as well as in the pressure plate assembly. In addition, some clutches for heavy duty application have two friction plates and an intermediate pressure plate.

Different types of clutches are as follows

1. Friction clutches

- a) Single plate clutch.
- b) Multi plate clutch (i) wet (ii) dry
- c) Cone clutches (i) External (ii) Internal

SINGLE PLATE CLUTCH:

A simplified sketch of a single plate clutch is given in the Fig. 3.3. It is most common type of clutch used in motor vehicles. Basically, it consists of only one clutch plate (Fig. 3.4) mounted on the splines of the clutch shaft. The clutch plate is held between the flywheel and the pressure plate is bolted to the flywheel and is free to slide on the clutch shaft when the clutch is operated. There are six springs (the number may vary depending on the design) arranged

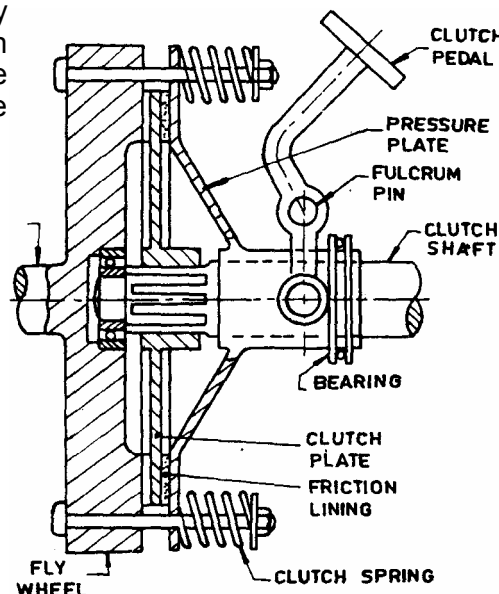

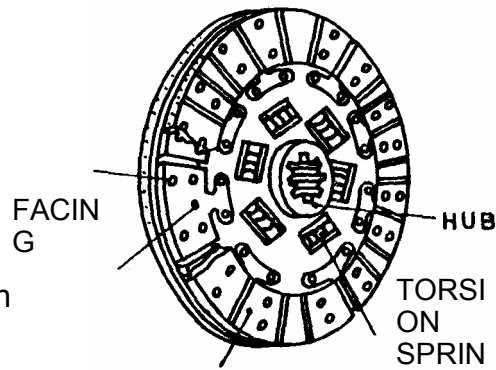

circumferentially which the clutch in engaged attached

to the clutch plate on both sides to provide two G annular friction surface for the transmission of power. Due to the friction between the flywheel, clutch plate and pressure plate, the clutch plate revolves with the flywheel. As the clutch plate revolves, the clutch shaft also revolves. Clutch shaft is connected to the transmission. Thus the engine power is transmitted to the crank shaft to the clutch shaft. A pedal is provided to pull the pressure plate against the spring force wherever it is required to be disengaged. Ordinarily it remains in engaged position as shown in the Fig. 3.3

provide axial force to keep position. Friction linings are

When the clutch pedal is pressed, the pressure plate is moved to the right against to the force of spring, and the clutch plate becomes free between flywheel and the pressure plate, This is achieved by means of a suitable linkage and through bearing. With this movement of the pressure plate, the friction plate is released and the clutch is disengaged.

MULTIPLATE CLUTCH

Multi plate clutch consists of a number of clutch plates, instead of only one clutch plate as in the case of single plate clutch. As the number of clutch plates are increased, the friction surface also increase. The increased number of friction surface obviously increases the capacity of the clutch to transmit torque the plates are alternately fitted to the engine shaft and the gear box shaft.

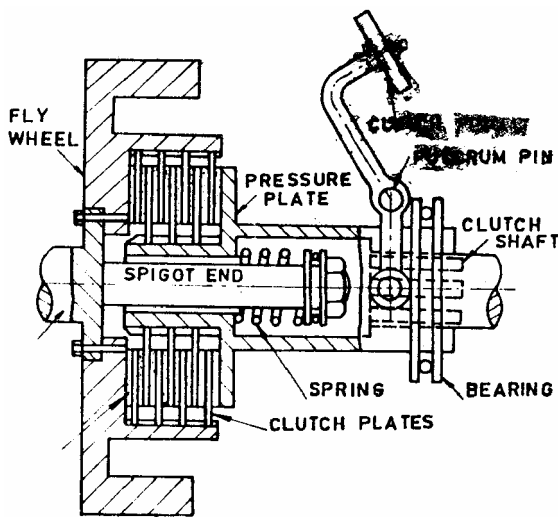

In this clutch there are four pressure plates and four friction plates as shown in Fig. 3.5 These pressure plates are linked to the clutch cover by means of studs. The clutch cover is fitted to the fly wheel. The first friction plate is between the first and second pressure plate. The second friction plate is between the second pressure plate and third pressure plate and so on. The link mechanism is the same as the one used in the single plate clutch. The friction plates are

connected to the clutch shaft by means of splines arrangements.

While the flywheel is rotating the pressure plates rotate and press against the friction plates. This cause to rotate the friction plate also. The clutch shaft is then rotated. When the pedal is pressed the flywheel continues

to rotate. The friction plates are then released. This happens because they are not fully pressed by the pressure plates. The friction plates are thus free of rotation. The clutch shaft also stops rotating.

The multi plate clutches are used in heavy commercial vehicles, racing cars and motor cycles for transmitting high torque. the multi plate clutches may be dry or wet. When the clutch is operated in an oil path, it is called wet clutch, The wet clutch are generally used in connection with, or as a part of the automatic transmission.

MOTOR CYCLE CLUTCH:

In a motor cycle, a single plate clutch is not able to transmit the power from the engine to the gear box, Therefore, a multi plate clutch is used. Multi plate clutch consists of a number of clutch plates, instead of only one clutch plate as in the case of single plate clutch. As this number of clutch plates are increased, the friction surface is also increased. The clutch is always kept immersed in oil. Due this the surface of the plate do not get too heated,

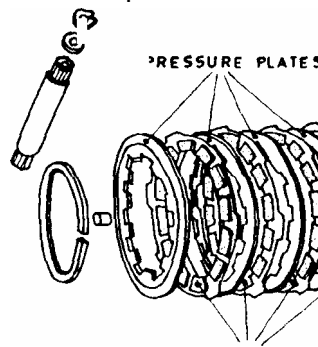

The various parts of the motor cycle multi plate clutch are shown in Fig.~.6. There are four clutch disks, four pressure plates, a hub and springs. When the control lever is operated the clutch gets disengaged. Then that presser

Fig.3.6 Motor Cycle Clutch

plates do not press on the clutch disks. Thus there is no transmission from the flywheel to the gear box. When the clutch lever is not in operation, the clutch gets engaged. The clutch disks do not get pressed by the pressure plates. The power is not transmitted from engine to the gear box. The clutch disks carry a clutch lining on both its sides. This develops the adhesive friction required for the operation of the clutch.

DIAPHRAGM CLUTCH:

The construction of this type of clutch is similar to that of the single plate type of clutch except that here diaphragm springs are used instead of the ordinary coil springs. In the free condition the diaphragm spring is of conical form but when assembled, it is constrained to an approximately flat condition because of which it exerts a load upon the pressure plate. A diaphragm spring type

clutch is shown in the Fig. 3.7a shows the clutch in the engaged position and Fig. 3.7 in the disengaged position. When the clutch is engaged, the spring pivots on the rear pivot rings as it is held in the clutch over, so that its outer ring contacts pressure plate, In this conical position of spring the clutch plates remains gripped, between the fly wheel and the pressure plate.

When the clutch pedal is pressed. the throughout bearing moves towards the flywheel, pressing the centre portions of the spring, which causes the rim to move backward. This removes the pressure on the pressure plate and the clutch is disengaged.

This type of clutch has some advantages over coil spring type clutches. It needs no release levers. The spring itself as series of levers. The pressure of the spring

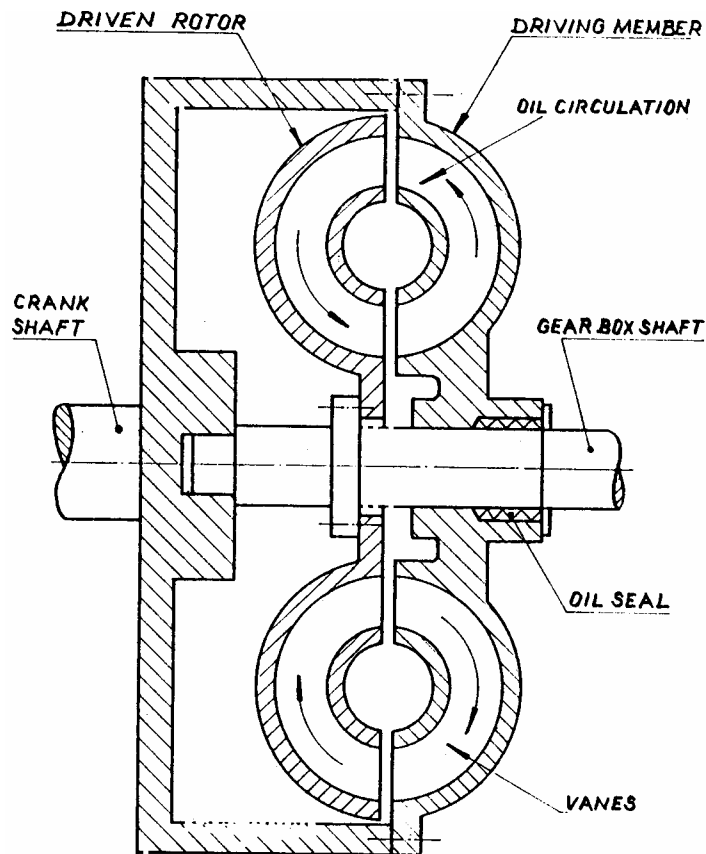

increases the flat position is reached and decreases as this caution is passed. The driver does not have to exert such heavy pressure to hold the clutch disengaged as with the coil spring type,

The fluid flywheel or fluid coupling is a hydraulic clutch. It is variably used in connection with epicyclic gear box in heavy vehicle application. (e.g.) Ashok Leyland Tiger.

The fluid fly wheel (Fig.3. 8) consists of a split housing rotated with the engine. Inside this housing is a turbine(or driven motor) which is connected by a shaft to this gear box. The housing rotated by the engine is known as the pump. The pump is divided up into a number of cells correspond to similar openings in the turbine. The fluid fly wheel housing is filled with the oil. As the driving member rotates, the fluid flows outwards under the action of centrifugal force, and circulates from the pump cells to turbine cells. Because the fluid is also being carried round by the pump member, the fluid tends to rotate the turbine. In fluid flywheel the pump and the turbine should not rotate at the same speed because if they rotate at the same speed fluid circulation will cease. Hence the turbine speed will be less than that of the pump. This is known as 'Slip' At maximum efficiency the amount of slip becomes 2% The slip being greater at lower speed. Complete disconnection of the drive is not possible with fluid coupling and it is not suitable for use with an ordinary gear box.

Fluid flywheels require less attention than friction clutches and need adjustment. The drive is taken up smoothly, torsional vibration of the crank shaft and the transmission are damped out, the fluid absorbs transmission shock when breaking (or) coasting down a hill the clutch pedal is eliminated.

GEAR BOX:

PURPOSE OF GEAR BOX:

When a vehicle is starting from rest, accelerating hill climbing and meeting other resistance a high tractive effort is required at the driving wheels. The tractive effort at the wheels is dependent upon the torque developed by the engine which increases, within limits as the engine speed increases, reaching a maximum at some predetermined number of revolutions. If the engine was coupled directly to driven axle, the engine speed would necessarily be low when

high driving torque is required. To deal with the problem the engine revolutions are maintained by reduction gears. The reduction gears are enclosed in a metal box called a gearbox. The road wheels rotate at lower speed to suit the following operating conditions of the vehicle.

1) Thus by maintaining the optimum engine speed the gear box can multiply the engine torque to meet the torque requirement at the road wheels.

2) In order to reverse the vehicle the gear box changes the direction of drive from engine to road wheels.

3) The gear box also provides a neutral position so that the clutch may be left in engagement while the engine is running.

TYPES OF GEAR BOX:

The gear boxes are classified according to the method of engaging the gears on the main shaft to the gear on the counter shaft. They are given under:

1. Sliding mesh type
2. Constant mesh type
3. Synchromesh type
4. Epicyclic gear type

SLIDING MESH GEAR BOX:

It is the oldest and simplest form of a gear box. A three speed sliding gear

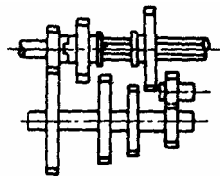
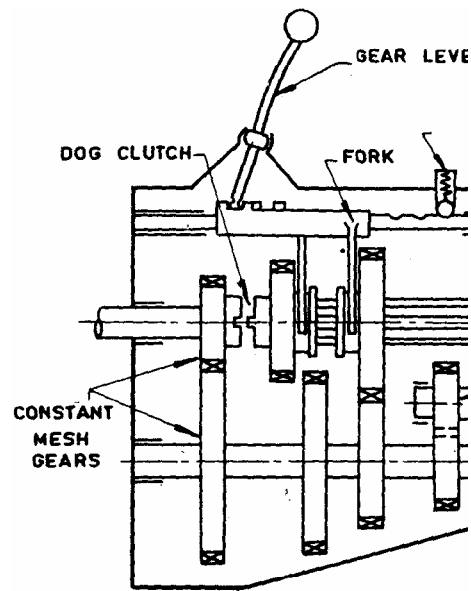

box is shown in (Fig. 3. 9.) in first gear position The clutch gear is rigidly fixed to the clutch shaft it remains always connected to the driven gear of the countershaft. Three other gears are also rigidly fixed to the counter shaft (lay shaft). They are second speed gear, first speed gear and reverse speed gear. Two gears are mounted on the splined main shaft which can be shifted by the shifter yoke when the shift lever is operated. These gears are the second speed gear and first and reverse speed gear. They can be connected to the corresponding gear of counter shaft. A reverse idle gear is mounted on another shaft and always remains connected to reverse gears of the counter shaft.

GEAR IN NEUTRAL

When the engine is running and clutch is engaged, the clutch shaft gear drives the counter shaft gear. The counter shaft rotates opposite in direction to the clutch shaft. In neutral position, only the clutch shaft gear is connected to the first gear on the counter shaft. The main shaft turns in the same direction as the clutch shaft. A gear reduction of approximately 3 :1 is obtained.

By operating the gear shift lever, the larger gear on the main shaft is moved along the shaft to mesh.

SECOND GEAR:

By operating the gear shift lever, the larger gear of the main shaft is demeshed from the first gear of the counter shaft and then the smaller gear of the main shaft is meshed with the second gear of the counter shaft. A gear reduction of approximately 2:1 is obtained. (Fig. 3.9a)

THIRD OR TOP OF HIGH SPEED GEAR:

By operating the gear shift lever, the second gear of the main shaft and counter shaft are demeshed, and then the second and top gear of the main shaft is forced axially against the clutch shaft gear. External teeth on the clutch shaft gear mesh with the internal teeth in the second and top gear. The main shaft turns with the clutch shaft and gear ratio of 1:1 is obtained (Fig. 3.9b).

REVERSE GEAR:

By operating the gear shift lever, the larger gear of the main shaft is meshed with the reverse idler gear. The reverse idler gear is always in mesh with the counter shaft reverse gear. Interposing the idler gear between the counter shaft reverse gear and main shaft bigger gear, the main shaft turns in the direction opposite to that of the clutch shaft. This reverses the rotation of wheels so that, the vehicle backs (Fig. 3.9d).

CONSTANT MESH GEAR BOX

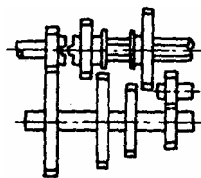

b. THIRD OR TOP GEAR

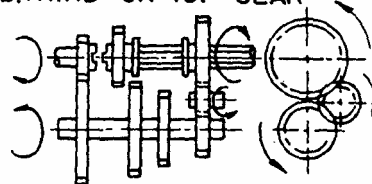

The construction of the constant mesh gear A is similar to the sliding mesh gear box but the difference is only that all the gears of the main shaft are in constant mesh with the corresponding gears of the counter shaft (lay shaft). And all the gears are helical gears.

Fig3. 10 shows a constant mesh gear box. It consists of a clutch shaft, a counter shaft and a main shaft'

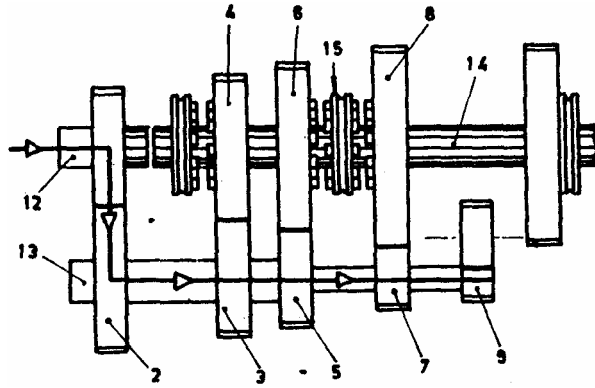
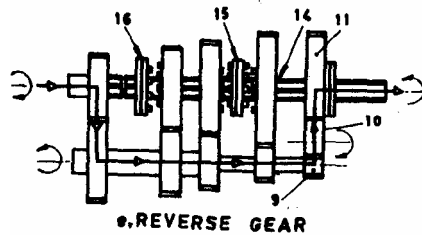
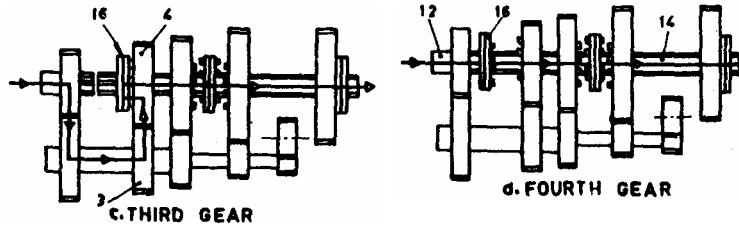
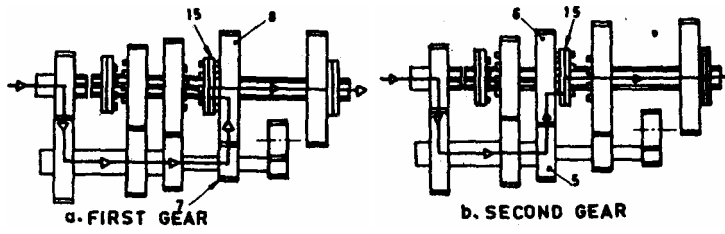

Fig. 3. 10 Constantmesh Gear Box



Gears (2), (3), (5), (7) and (9) are fixed to the counter shaft. They do not slide along it. Gear wheels (4), (6) and (8) are not fixed to the main shaft. Therefore, these gears can revolve freely around it. Gear (4) of the main shaft is in constant mesh with gear (3) of the counter shaft. Similarly, gear (6) is in constant mesh with gear (5) and gear (8) with gear (7). All the gears are shown in the neutral position.

Power transmission in the four gear positions is given below:

FIRST GEAR :

Collar (15) is splined to the main shaft. It can slide along the shaft. The collar revolves with the shaft. It is locked to gear (8) by means of a dog clutch. Power is transmitted from gear (7) to gear (8) and then to collar (15). The collar rotates the main shaft.

SECOND GEAR:

Collar (15) slides in the opposite direction along the main shaft. This collar is locked to gear (6) by means of a dog clutch. Power is transmitted from gear (5) to gear (6) and then to collar (15). The collar rotates the main shaft.

THIRD GEAR

Collar (16) is splined to the main shaft. It can slide along the main shaft. This collar revolves with the shaft. This collar is locked to gear (4) by means of a dog clutch. Power is transmitted from gear (3) to gear (4) and then to collar (16). The collar rotates the main shaft.

FOURTH OR TOP GEAR :

Collar (16) is locked directly to the clutch shaft (12) by a dog clutch. Power is transmitted from the clutch shaft to main shaft.

Here, collars (15) and (16) are not engaged. Gear (11) can slide along main shaft (14). Gear (10) is the reverse gear. Power is transmitted from gear wheel (9) to gear wheel (11), through reverse gear (10). Due to this the main shaft rotates in the opposite direction. Thus, the vehicle moves in the reverse direction.

SYNCHRO MESH MECHANISM:

The modern cars use helical gears and synchromesh devices in the gear boxes, that synchronize the rotation of gears that are about to be meshed. This eliminates clashing of the gears and makes gear shifting easier. The synchromesh gear box is similar to the constant mesh gear but the synchromesh gear box is provided with a synchromesh device by which the two gears to be engaged are first brought into frictional contact which equalizes their speed after

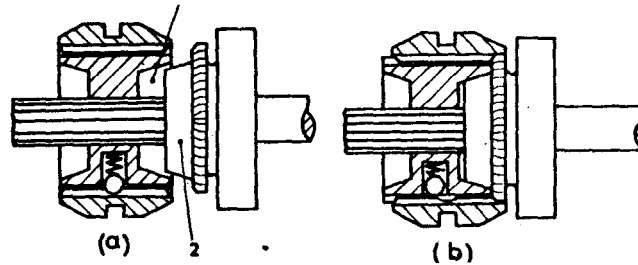
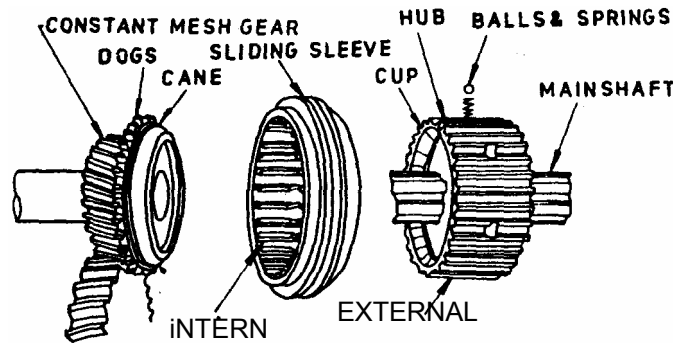

Fig. 3. 11 Synchromesh Unit



which they are engaged
synchromesh devices are
fitted only on top gears.

first gear do not have synchromesh
engaged when the vehicle is

GEAR BOX

of Synchromesh

smoothly. In most of the cars, the
not fitted to all the gears. They are
Reverse gear and in some cases the
device since they are intended to be
stationary.

To understand the working of the gear box Fig. .3. 11 shows in steps how the synchromesh unit is engaged.

When the synchromesh is disengaged, gear are running free on the mainshaft and the two gears to be engaged are running at different speeds. When the selector lever is moved, the sliding sleeve and sliding gear slide together because of the pressure of the spring loaded balls until the cones on the gears contact. Both gears have now reached, the same speed. As the selector lever is moved further, the sliding gear cone is held against the high speed gear cone and the sliding sleeve press the spring loaded balls and slides over on to the high speed gear there by locking the gear to it. Since both pinion and synchromesh units are moving at the same speed, this engagement is done without noise or damage to the dogs. A slight delay is necessary before engaging the dog teeth so that the cones have a chance to bring the synchronizer and pinion to the same speed.

SYNCHROMESR

The Synchromesh gear box is similar to the constant mesh except the synchromesh Unit Fig.3.J 4.ashows a synchromesh type gear box having Five speeds. The gear positions shown in Fig1a Corresponds to situation when the Vehicle is in Neutral lear,

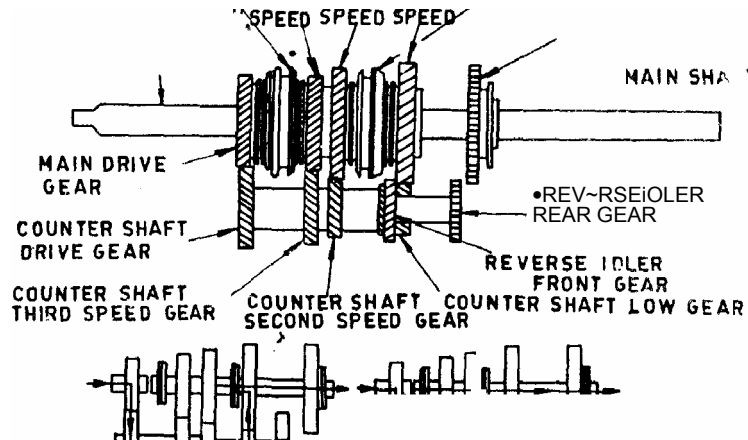

1.FIRST GEAR

Figure a shows the power flow through the transmission in first. The 1-2 synchronizer

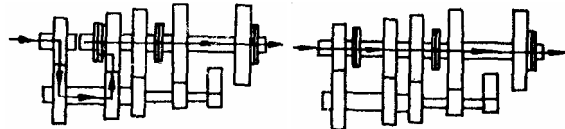

has been moved to the right of its internal teeth engage the external teeth of the first speed gear.

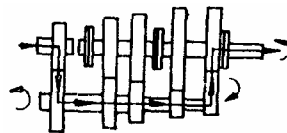

2.SECOND GEAR

Figure b shows the power flow through the transmission In used gear. The 1-2 synchronizer has been moved to the lift so its Internal teeth engage the external teeth of the second speed gear.

a FIRST GEAR

b SECOND GEAR

Figure c shows the power flow brought the transmission in has been moved to the right so its internal teeth engage the external teeth of the third-speed gear.

4.FOURTH GEAR

Figure d shows the power flow throw the transmission in fourth gear. The 3..4 synchronizer has been moved to the left, so its internal teeth engage the external teeth of the clutch gear.

In reveuse. both synehronimbers sre is the neutiat peeldom. The reverse gear has ~etn rmovei to the left, so it engage the reverse idler gear. Now, the elba gear in the train causes the maim shaft to trw its the reverse arcuon. so the car moves bacliward.

EVICYCLIC GEAR BOX:

SIMPLE EPICYCLJC GEAR TRAIN

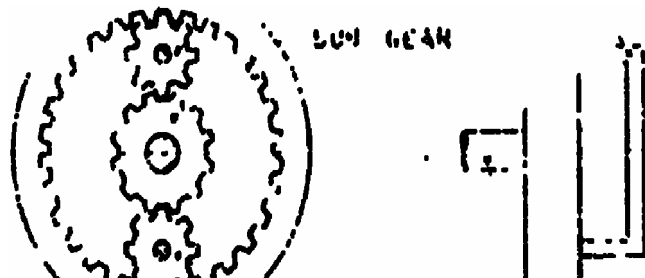

the ring gear cannot move, the planet gears are forced to climb over it. During this position, the ring gear acts as a track for the planet gears to move over. The driven shaft which is connected to the planet gear carrier is thus rotated

When the ring gear is released it is free to move in consequence to the rotation of planet gears which rotate around their axis. During this position there is no movement of planet carries and hence the driven shaft remains stationary.

A planetary gear box contains a number of such units in different sizes to obtain

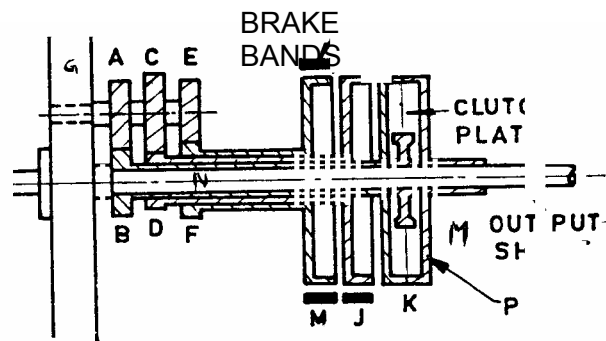

various speed reductions. Fig.3.13 Epicyclic Gear Box

In a simple epicyclic gear

set, There may be six possible speeds, four of which are forward and two reverse.

- i. Forward, fast output speed: This is obtained when planet carrier is driving, ring gear is driven and the sun gear is held stationary.
- ii. Forward, very fast output speed This is obtained when planet carrier is driving, sun gear is driven and the ring gear is held stationary.
- iii. Forward, slow output speed: With ring gear driving planet carrier driven and the sun gear stationary, this comes about
- iv. Forward, is slow output speed This results when the sun is driving, planet carrier driven and the ring gear stationary.
- v. Reverse, slow output speed: This is obtained when the sun gear is driving~ the ring gear is driven, and the planet carrier is stationary.
- vi. Reverse, fast output speed This condition is obtained with the ring gear driving, sun gear driven and the planet carrier stationary.

CONSTRUCTION AND OPERATION OF EPICYCLIC GEAR BOX:

Fig 3.13' shows an epicyclic gear box, The compound gear ACE is mounted on a pin fixed to a wheel G. The compound gear is free to rotate on the pin. Gears, A, C and E are meshed with the three different gears B, D and F respectively, which are connected in turn to the drums

H, J and K. The drums H and J have brakes in outer circumference and drum K is provided with a number of clutch plates. A hub is fitted to the flywheel spigot shaft N to which a number of clutch plates are attached. When the member M is pressed against the clutch plate, it engages the clutch, thereby connecting the shaft N to the output shaft **P**. directly. It is top speed gear.

To obtain low speed gear, disengage the clutch and apply on drum J, with the help of gear change lever. This action locks the gear D, thereby decreasing the speed of gear B and hence that of the output shaft.

To obtain reverse gear, disengage the clutch and apply brake on drum M. This locks the gear F. thereby reversing the direction of rotation of B, with respect to the input shaft. The speed of B is also reduced.

PROPELLER SHAFT:

This is the shaft which transmits the drive from the gear box to the bevel pinion or worm of final drive. It consists of three parts.

Shaft.

One or two universal joints, depending upon the type of the rear axle drive used. The universal joints act for the up and down movements of rear axle when the vehicle is running.

Slip joint . Depending upon the one slip joint he there in the shaft. This serves to adjust the length of the propeller shaft when deranged by the rear axle movement.

Fig shows propeller shaft, with two universal joint.~ at the ends and a slip or sliding joint. Slip joint is formed by the internal splines on the sleeve attached to he left universal joint and external splines on the propeller as shown.

'he rotary motion of the transmission main shaft is carried out the propeller shaft to the differential, causing

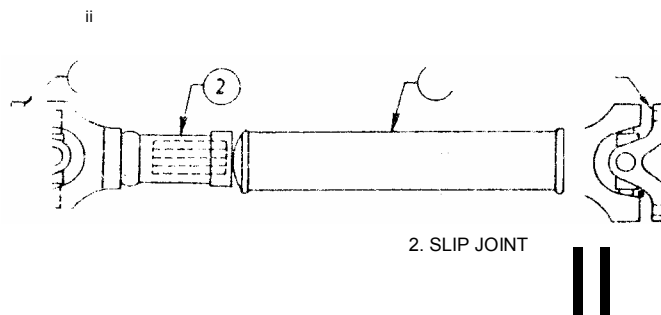

- I. UNIVERSAL JOINT
- 3. HOLLOW SHAFT

whoels to rotate. ~The propeller shaft has to with with the torsional stress of the transmitting torque, it must be light and well balance so that vibration and whip will not occur at high speed. i-or those reasons, it is made of strong steel tube.

In so vehicles, torque piece propeller shaft is used. It consist of two' propeller shaft supported in the middle by o self- ball in a cross member of the chassis. In all there are, three universal joints two slip

UNIVERSAL JOINT

An universal joint is used where two shafts are connected at to transmit torque. In the transmission system c-f a motor vehicle, the transmission main shaft, propeller shaft and the pinion shaft are not in one lies hence the coincide between them are made by the universal one joint is used to.

TYPES OF UNIVERSAL JOINT

1. Cross type or spider and two yoke type
2. Pot type joint
3. Ball and turnnion type
4. Constant velocity type
5. Flexible ring universal joint

1. CROSS TYPE OR SPIDER AND TWO YOKE TYPE:

axis **yy**. An Improved form of this joint uses needle roller bearing to support the cross in the yoke. This result in increase of joint efficiency. To allow for the telescopic movement an extnded hub of one yoke is internally splined as shown in figure 3. 15a.

SPLINES FOR SLIDING JOINT

Cross'type universal joint

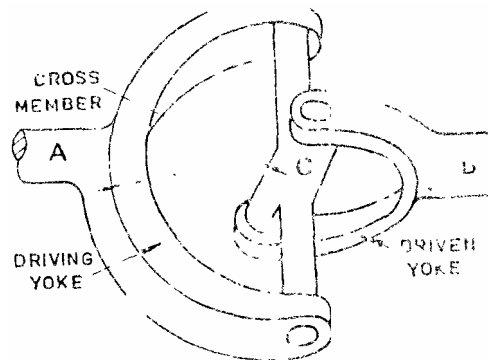

Cross Tube universal joint

2. POT TYPE JOINT:

Pot type of joint is another

SPHERICAL BLOCK SHAFT

Fig. 3.16 Pot Type Joint
kind of universal joint Fig:3~
16 gives the general
arrangement of this
type of joint. The
end of one shaft is
specially shaped

and
carries two hemi-
spherical shaped
blocks attatched to it by
means of a pin. These
blocks slide in the pot;
the pot itself is carried
by the second shaft.
This arranand axial
movements.

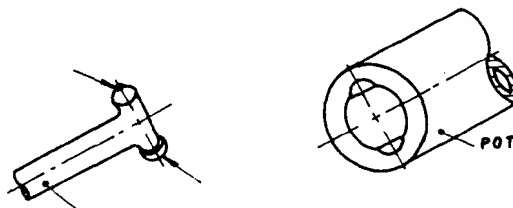

In most automobile vehicles the final drive is embodied in rear axle. But in various popular vehicles with front wheel drive and a few special purpose vehicles with four wheel drive, it becomes necessary to consider final drives as units dependent of their positions.

FUNCTIONS OF FINAL DRIVE:

In a motor vehicle the final drive has two purposes.

1. To provide a permanent speed reduction. For motor cars the reduction is usually about 4:1 and 10 :1 in heavy vehicle.
2. To turn the drive through 90° so that the torque may be transmitted from propeller shaft to the rear axle.

CONSTRUCTION OF FINAL DRIVE:

The final drive consists of a

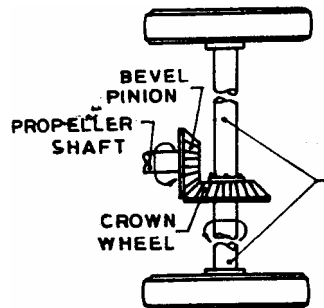

TYPES OF GEARS:

There are three types of the final drive gearing:

- a) Straight bevel gears
- b) Spiral bevel gears
- c) Hypoid gears.

bevel pinion and crown wheel (ring gear). as shown in Fig 3.17. The bevel pinion is mounted on the shaft which is connected to the propeller shaft generally through a universal joint. From the crown wheel the drive goes to rear axles through differential.

STRAIGHT BEVEL GEARS :(Fig.3 ISa)

These contain the straight *teeth*. They are therefore simplest and thus the cheapest of all type.

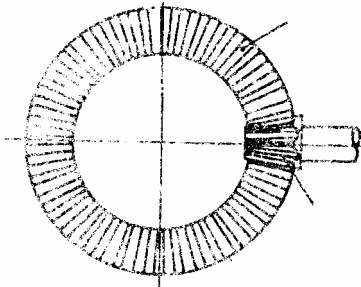

BEVEL GEAR OF STRAIGHT TEETH

% EVEL PINION OE 51 1/4 I AIGHT YEETH

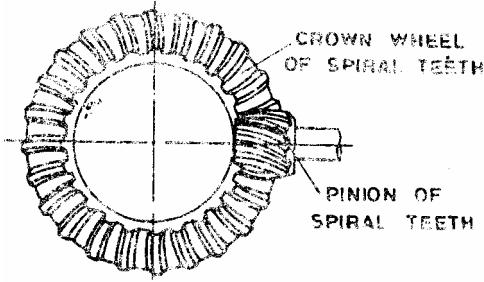

C Hypoid Spiral Gear

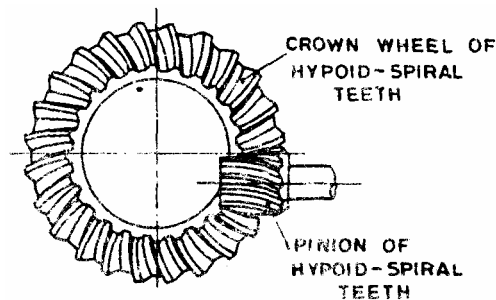

ADVANTAGES OF HYPOID GEARS:

1. This permits a lower position of the propeller shaft thus allowing a low chassis height.
2. Wiping action takes place between the teeth as the teeth mesh and demesh, The result is smooth running.
- 3, the same size of spiral bevel crown wheel the shape and size of pinion teeth in hypoid drive is greater thus can withstand high torque.

WORM AND WORM WHEEL DRIVE: Fig.3.18d

Instead of bevel pinion and the crown wheel, the worm and worm wheel arrangement is also used frequently. This gives a quiet and efficient drive. Further, larger gear reduction as compared to the bevel pinion type where double reduction has to be employed. The worm can be mounted either below the wheel axis level for low chassis height or above the wheel axis level to allow ground clearance.

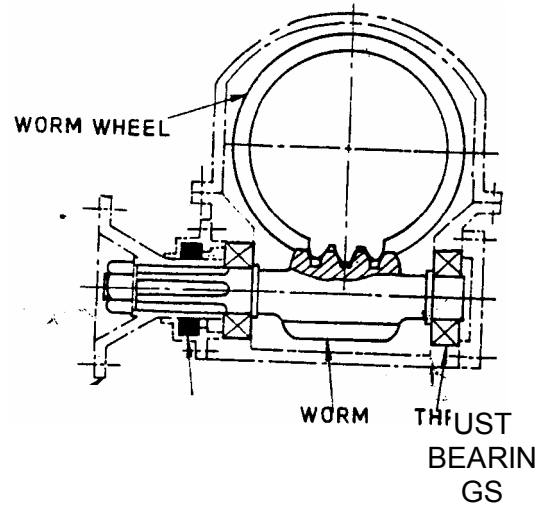

WORM WHEEL

DIFFERENTIAL

If a vehicle travels in a straight line, the two rear wheels turn on the road exactly at same speed. There is no relative movement between the two rear wheels. But when the vehicle takes a turn, the outer wheel travels on a longer radius than the inner wheel. The outer wheel turns faster than the inner wheel, that is, there is a relative movement between the two rear wheels. If the two rear wheels are rigidly fixed to a rear axle the inner wheel will slip which will cause rapid tyre wear, steering difficulties and poor road holding. Therefore there must be some devices to provide relative movement to the two rear wheels when the vehicle is taking a turn. The differential serve this purpose,

The outer wheel turns faster than the inner wheel when the car is taking a turn. This requires a differential.

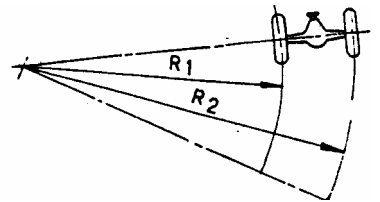

The function of the differential is to allow each rear wheel to rotate at different speeds during running but at the same time transmit equal torque to each wheel when both wheels have equal traction.

TYPES OF DIFFERENTIAL

- (i) Conventional
- (ii) Power lock or Non-slip
- (iii) Double reduction type.

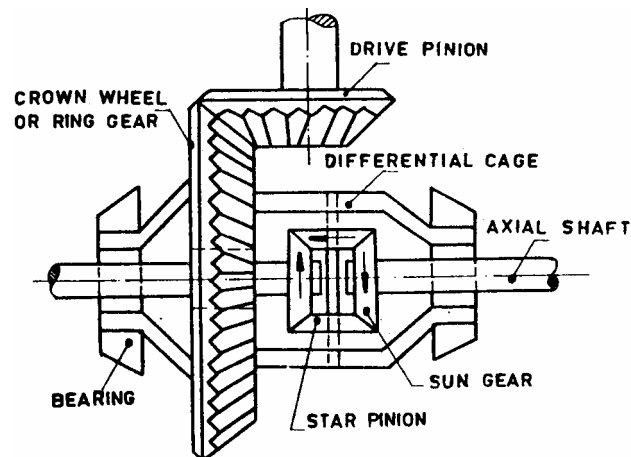

CONVENTIONAL TYPE (CONSTRUCTION)

It consists of a cage which contains differential gears. The differential gear (Fig..3.21) consists of two sun gears

Fig .3.21 Differential

and four star pinions all the bevel type. The star pinions are fitted on a pin if there are two in number and a spider, if four are in number. The pinions are free to move around their axes. The pin or spider is held in between the two parts of the cage which encloses the differential gears. The sun gear and star pinions are always in mesh with each other. The differential assembly is supported on taper roller bearing provided on both sides

of the cage. When installed in the drive axle, the whole assembly moves around the bearing.

The ring gears or crown wheel is attached to the differential cage which forms part of the final drive. Drive is given to the ring gear by means of drive pinion to which propeller shaft is attached.

Such gears are located parallel to ring gear inside the differential cage and face towards each other. Shaft of each wheel is splined into the sun gear of that side.

WORKING OF DIFFERENTIAL.

When the vehicle is moving on straight bevel road and the resistance effecting both the driving wheels is the same, there is no relative movement among the differential gears. The whole arrangement meshed together moves as one unit and both the half shafts in the driving wheel rotate at the same speed.

When the front wheels are turned to any directions to take a turn, a binding force acts on the inner wheel being nearer to the point around which wheels move in a circle. The sun gear of the side is held slow in relation to the movement of the complete cage or crown wheel. When the vehicle is going straight on level road, the power is divided equally at the differential, one half flowing to one side wheel and the other half flowing of the other side wheel. While taking a turn when the bonding acts on the inner side sun gear and its speed is slowed down, the star pinion rotate the other side sun gear at a speed as a result of loss on the inner side and gain on the outer side plus the speed at which the complete differential assembly is rotating, This results in a faster movement of the outer wheel than the inner one. Thus the differential is functioning

Rear Axles

TORQUE REACTION:

The forces experienced by the rear axle are given under

- i) Weight of the body
- ii) Torque reaction
- iii) Driving thrust
- iv) Braking thrust
- v) Side thrust Torque Reaction

The propeller shaft drives a torque to the pinion and the pinion will have to roll round the crown wheel taking with it casing. This tendency is also present when the vehicle is running. This torque is equal and opposite to the driving torque applied to the road wheels. This phenomena.. non is called torque reaction. In the same way the braking torque on the axle casing is opposite in direction to the torque reaction. This opposition of the casing prevent, bending of the propeller shaft.

3.10 REAR AXLE DRIVES:

The load and weight of the body of the vehicle is communicated to the rear axle through the springs which are rigid with the casing. To transmit the torque from the gear box to the rear axle, the common drives are used as given under:

3.10.1 HOTCH KISS DRIVE:

This drive is very simple and generally used in the vehicles. The arrangement of the parts is shown in this

9

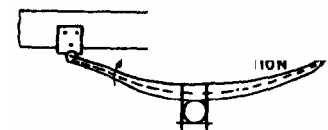

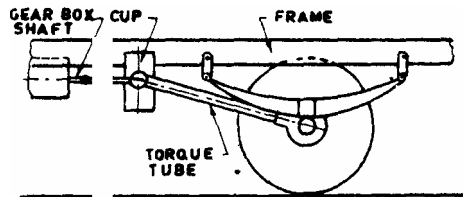

Figure 3.22 In this case the springs beside taking weight of the body, also take the torque reaction, driving thrust and the side thrust.

Drive the frame with the bracket and rear end is supported in a shackle with the pins. The propeller shaft is provided with two universal joints and one sliding joint.

Due to torque reaction the front half spring deflects as shown in figure 3.22e1t means that the driving thrust is transmitted to the frame by this portion of the spring.

When the spring deflects . of spring in the manner shown to the torque reaction bevel pinion shaft will tend to tilt its axis. If there is one universal joint near the gear box then under the torque reaction the propeller shaft will bend. Therefore, to avoid the bending of the propeller shaft another universal joint is used at its rear end.

Again when axle moves up and down relatively to the frame it has to move in a circle whose centre lies at the front end of the spring. Then propeller shaft also has to move in circle keeping its centre at the front universal joint. As these two centres do not coincide, therefore, the length of propeller shaft always has to vary this condition which is accommodated by the sliding joint in the propeller joint.

3.10.2 TORQUE TUBE DRIVE:

In this type of drive, the spring take only the side thrust besides supporting the body weight. The coil springs, however, cannot take any side thrust and hence a separate member is required for the same The torque reaction and

the driving thrust are taken by another member which is called the torque tube. One end of the torque tube is attached to the axle casing, while the other end which is spherical in shape fits in the cup fixed to the frame a

PROPELLER

Torque Tube As it is seen the Drive torque tub. Encloses the propeller shaft. In this case no universal joint is provided at the rear end of the propeller shaft. Also no sliding joint is need in The propeller shaft.

Clearly the torque reaction and the driving thrust are taken by the torque tube. In this case, the bevel pinion shaft axis will always pass through the universal joint at the front end of the propeller shaft if this joint is situated exactly at the centre of the spherical end of the torque tube. Due to this reason no universal joint is at the rear end. Since both pinion shaft and propeller shaft will work about the same centre that of the spherical cup while moving up and down the axle then no sliding joint will be necessary.

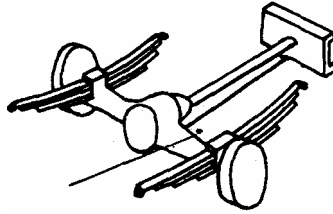

RADIUS ARM DRIVE:

The radius arm drive method (Fig5.4) uses two torque rods or radius arm to transmit the driving thrust to the frame. The radius arm are connected between the rear axle and the frame by connections that allow relative motion between the two. The torque reactions is resisted by the suspension springs. The springs must, therefore, be stiff, enough
 The torque arm drive (Fig.3.23a) consists of a tubular arm connected between the rear axle housing and the frame with a rigid connection at the axle housing and a ball and socket joint at the frame. The propeller shaft torque unlike torque tube drive members remains open; apart from This the working principle Torque Arm of exactly same as the torque-tube drive.

REAR AXLE:

There are two types of rear axles; dead axle and live axle. A dead axle does not rotate with the wheels but the wheels rotate on it. They support the rear weight of the vehicle. A live axle takes the load and at the same time, also drives the wheel connected to it. The live axle is not a single piece, but it is in two halves connected by the differential known as half shaft. In a four wheel drive all the axles are live axles. In case of rear-wheel drive vehicle the front axles are dead whereas in front-wheel drive vehicle the rear axles are dead. Almost all rear axles on modern passenger cars are live axles.

TVYPES OF REAR AXLES:

Depending upon the method of supporting the rear axles and mounting~ the rear wheels, the rear axles are of three types:

- a) Semi floating axle
- b) Full floating axle
- ci Three quarter floating axle.

SEMI FLOATING AXLE:

-Fig. shows a semi floating type of rear axle. A bearing is located between the axle and inside the axle casing.

Therefore, it needs to be of a larger size, for the same torque out put, than any other type. The inner end of the axle is supported by the differential side gear. It is thus relieved

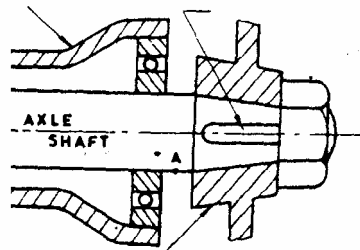

of the job of supporting the weight of the car by the axle housing. The outer end has to support the weight of the car and take end

thrust- the inner end Semi Floating Axle of the axle is splined to and the bearing, which causes the bending or shearing of the axle. The semi floating axle is the simplest and cheapest of all other types and widely 'used.

FULL FLOATING AXLE

This type is very robust one. And is used for heavy, vehicles. In this the axle shaft carry

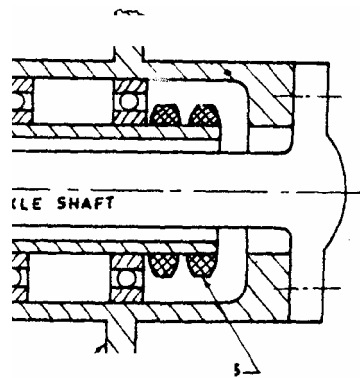

only the driving torque A full floating axle (Fig.3.25j) has two deep-groove ball or taper roller bearings, located between the axle casing wheel hub. The outer of the axle is made

flanged to which the wheel hub is bolted. The axle is not supported by bearings at either end, and its position is maintained by the way that it is supported at both ends: Thus the axle is relieved of all strains caused by weight of the vehicle on end thrust. It transmits only the driving torque. For this reason it is called full floating. The axle may be removed from the housing without disturbing the wheel by removing the nuts. An additional advantage of the design is the ability to withstand the vehicle even if it has a broken axle. This type of axle is more expensive and heavier than the other axles.

THREE-QUARTER FLOATING AXLE:

In the three quarter floating axle the single bearing located between the hub and the axle casing. Thus, the weight of the vehicle is transferred to the axle casing. Thus, the weight of the vehicle is transferred to the axle casing, and only the side thrust and driving torque are taken by the axle. The axle (Fig.3.26) is keyed rigidly to the hub, thus providing the driving connection and main maintaining the alignment of the

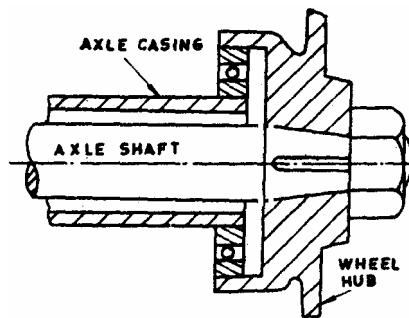

wheel: The inner end of this axle has the same construction as that of the semi-floating axle. As clear from the figure 3.26 the axle shaft do not take any shearing or bending loads due to the weight of the vehicle. However it has to take the end loads and driving torque. Although the three quarter floating axle is more reliable but it is not as simple as the semi floating axle.

ALTERNATE FUELS IN AUTOMOBILE

5.1. INTRODUCTION

At present every country is facing two major challenges namely energy crisis and environmental degradation. Crying need of the day is to mean fuel, more fuel and cheaper fuel. Moreover the growing use of petroleum fuels in the ever increasing number of automobiles is causing rapid degradation of environment in every country due to vehicle exhaust pollution. To meet this twin problems of fuel oil scarcity and air pollution caused by the growing use of petroleum fuel, alternate renewable clean burning fuel should be explored for using motor vehicles. Most prominent eco-friendly fuels are the bio-solar fuels namely alcohol, natural gas and hydrogen.

5.2 NATURAL GAS

CNG – an abbreviated version of compressed natural gas as an alternate fuel for automotive usage would be of great use in reducing the fuel consumption as well as patterns of pollutants. This alternate fuel reduces considerably the dependence on conventional automotive fuels, thus achieving a saving in terms of foreign exchange as well as reduction in emission of toxic pollutants responsible for urban ecological degradation.

Natural gas (CNG) comes under the promising alternate fuels.

5.2.1 Compressed natural gas

Natural gas is available in large quantities in India and does not need elaborate processing or refining, as is the case with other petroleum fuels. Natural gas is a natural hydrocarbon energy resource formed in the earth's crust by millions of years of biological action on organic matter. It occurs along with oil, deep in the earth's crust and is recovered from wells under very high pressure. It has very low levels of pollution, does not materially restrict vehicle performance and is far more economical to use than petrol.

Natural gas occurring as gas under pressure in rocks beneath the earth's surface are more often in solution with crude oil as volatile fraction of petroleum. This is composed mainly of methane (CH_4) with varying amounts of the paraffinic hydrocarbon family, ethane (C_2H_6), PROPANE (C_3H_8), BUTANE (C_4H_{10}) etc.

It is a clean burning fuel, no lead and sulphur compounds in the exhaust, simple and small molecular structure, very low carbon to hydrogen ratio, forms no deposits on spark plug, thus reducing engine maintenance cost.

The natural gas is compressed to a pressure of around 200 kg/cm^2 and stored in transportable cylinders of capacity ranging from 20 litres to 100 litres, which can be kept safely and conveniently on the automobile. These cylinders, usually called CNG cylinders, provide a good range for the vehicle for a travel from 250 to 350 Kms.

In general Natural gas are obtained from oil field as Associated Gas and Wastelands or landfills as a result of bio degradation.

The composition of Natural Gas can be given as following :

It is a mixture of hydrocarbons

General composition for Natural Gas

Methane (CH_4)	:	85 – 90 %
Ethane (C_2H_6)	:	5 – 7 %
Propane (C_3H_8)	:	2 %
Carbon di oxide	:	3 – 5 %
Others	:	1 %

Natural gas is received from pipeline and is compressed to 250 kg/cm² with the help of reciprocating compressors installed at Mother and On-line CNG stations. CNG is dispensed to vehicles at maximum 200 kg/cm² pressure.

Some of the physical properties of Natural gas (CNG) are :

- Colourless
- Odourless
- Non-toxic
- Lighter than air

5.2.2 Need for CNG

Following are some of the reasons why CNG is to be used.

1. Rising urban pollution
2. Rising global concern for environment
3. Rising vehicle pollution
4. Rising public awareness and expectations
5. Economics
6. Indigenous availability.

5.2.3 Characteristics of CNG

CNG is a safe fuel. Being lighter than air, it disperses easily into the atmosphere and does not form a sufficient rich mixture for combustion to take place. In this respect, CNG is superior to LPG or propane or even petrol. The excellent knock – resistance property of CNG allows use of a higher compression ratio for increased power output and fuel economy, compared to petrol. Due to its anti-knock property, CNG can be safely used in engines with a compression ratio as high as 12:1 compared to normal gasoline (ranges from 7.5:1 to 10:1) At these high compression ratios, natural gas fuelled engines have higher thermal efficiencies than those fuelled by gasoline.

CNG has a higher octane number than petrol, making it possible for CNG engines to operate at a higher compression ratio than petrol engines without knocking. The fuel efficiency of CNG engines is better than that of petrol engines. However, compared to diesel engines, the compression ratio is lower for CNG engines. CNG engines are efficient, easy to maintain and user-friendly solution to overcome environmental problems. CNG also allows the use of catalytic converter more efficiently than diesel.

5.2.4 Constraints in CNG

Gas availability

Capacity planning becomes difficult due to non-availability of demand projections

Availability of CNG equipment

Pipeline network infrastructure

Competition from other fuels

5.2.5 Description of CNG system

The CNG system essentially incorporates two kinds of refueling principles based on

- a. Mother-Daughter concept
- b. On-line station concept.

In Mother-Daughter concept, MOTHER STATION is a compressor station, which caters compressed gas. The compressed natural gas (CNG) thus produced is transported to various refueling stations with the help of LCV/ trailer mounted cascade of cylinders. The refueling stations, where a essentially retail dispensing of CNG takes place, is called DAUGHTER STATIONS, which are the Retail Outlets (Ros) of CNG.

The working pressure as adopted in India has a range of 240-250 kg/ cm². To avoid transportation of high pressure gas in urban areas, the concept of 'On-line Stations' has also been used in India and many other countries where gas is tapped from city utility/ gas trunk line compressed, stored and dispensed at the same station, thereby eliminating additional expenses of transportation of cascades with CNG. This concept is not widely used due to the fact that urban areas are yet not linked with natural gas grids. Indian cities of Mumbai, Delhi and Surat have such on-line stations.

Comparative properties of available fuels

PROPERTIES	UNIT	PETROL	DIESEL	CNG
Calorific Value	KCAL/KG	11200	10850	10600
Relative density	AIR = 1	2.4	3.9	0.65
Autoignition Temperature	°C	232-282	225	540
Flammability Limit	% IN AIR	1-8	0.6-5.5	5-15
Flame temperature	°C	1977	2054	1790
Octane number	-	87	-	127
Cetane number	-	10	45	10

5.2.6 Advantages of using compressed natural gas (CNG) over diesel

1. Natural gas (CNG) is lighter than air and therefore dispersed quickly in the event of leakage instead of puddling like Petrol and Diesel.
2. Natural gas ignites at higher temperature (550 to 704 deg.c) than petrol and diesel.
3. The explosive limit of natural gas mixture is higher than air- diesel mixture.
4. Because of the flammability limits and high self-ignition temperature, fire or explosion is less likely in case of natural gas in the event of fuel leak. This supports the high degree of safety claimed in the use of Compressed Natural gas (CNG).
5. Natural gas provides clean burning characteristics.
6. Natural gas does not saturate flammable materials.
7. Due to higher oxygen required its combustion reduced, NOx pollutant, thus reducing the formation of Nitric acid in the Lungs Toxicity.
8. Due to proper combustion with homogeneous mixture of fuel and air reduced unburnt hydrocarbon (HC)) will reduce the environment pollution of Photochemical smoke-visibility.

9. Natural gas having good chemical composition and with low carbon molecules reduces low emission of CO.
10. Due to proper burning of fuel in the cylinder and nature of chemical and physical properties reduces Particulate Matter (PM).
11. Compared with other fuels natural gas is very economical and environmental friendly one.
12. Use of CNG will reduce the human effect such as lung cancer and natural cough and other diseases.

5.3 GAS POWERED VEHICLE

LPG fuel requires a special fuel system. There are actually two types of LPG that have been used for automotive-engine fuel, propane and butane. Of these, propane is more widely used. Thus, it can be used in any climate where temperature is below 0°C, since it is liquid below that temperature. If it remains liquid, it will not vaporize in the fuel system and will never reach the engine.

When the pressure is induced, the fuel vaporizes. Thus, the system must have a pressure-tight fuel tank to store the fuel at high-pressures. A typical LPG fuel system is shown in figure. Pressure forces the fuel through the filter, high-pressure regulator, and vaporizer. The high-pressure regulator reduces the pressure so that the fuel starts to turn in to vapor. This vaporizing process is completed in the vaporizer. The vaporizer has an inner tank surrounded by a water jacket through which cooling-system water passes. The water adds heat to the fuel so that it is fully vaporized. It then passes through the low-pressure regulator, where the pressure is further reduced. It then enters the carburetor. The low-pressure regulator reduces pressure to slightly below the atmospheric pressure. This prevents it from flowing into the carburetor when the engine is off. Fuel will flow only when the engine is running and there is a vacuum in the carburetor venturi. LPG fuel systems have been used on some cars, trucks, buses and forklift platform trucks.

Liquefied petroleum gas (LPG) is a mixture of light hydrocarbons, mainly propane / propene and butane / butanes. It is easier to distribute and store than compressed natural gas, liquefied at a pressure of 4-15 bar. LPG gas is used in view of conventional fuels because of their hydrocarbon rating and higher octane rating. The engine of LPG has been differed from conventional shapes. The LPG is disc shaped engine and differ in the numbers of valves and their arrangements.

system. India, Pakistan, and Sri Lanka import about 30-40 percent of LPG consumption. There is also a need to invest in refueling equipment required to transfer pressurized LPG from storage tanks to vehicles and to ensure that no LPG escapes during refueling. The lack of adequate investment in LPG refueling stations constraints widespread use of LPG in South Asia.

5.4 HYDROGEN AS FUEL IN AUTOMOBILE ENGINES

As the demand for the present day fuel of I.C. Engines - petrol and diesel increases, it ultimately stresses the scientists to find an alternate fuel to run the I.C. Engines, which lead to the use of Hydrogen as a fuel for I.C. Engines.

Hydrogen

Hydrogen is an excellent fuel, which could be the acceptable as permanent energy source that meets most of the obvious requirements for universal application in energy consumption in automobiles. It is available everywhere, since it is produced mainly from water.

The aspect of hydrogen as a fuel can be described by the following sections :

Production of Hydrogen

At present the hydrogen that is required by world industry is mainly produced by catalytic steam reforming of natural gas.

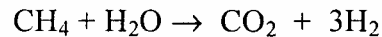

However, for large-scale use as a fuel, hydrogen will have to be produced only from the renewable sources, in order to prevent the extinction of Non-renewable sources as Petrol and Diesel.

Electrolysis of Water

Water is made electrically conducting, by adding a small amount of Sulphuric acid (H_2SO_4) or Potassium Hydroxide (KOH). Electric current is passed between the electrodes leading to the separation and collection of H_2 and O_2 separately. The energy efficiency of this process is about 75 percent.

Thermal Decomposition of Water

Water can also be split by the application of heat as

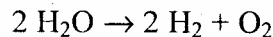

This however requires a temperature of 3000 to 4000°C.

2. Properties of Hydrogen

Hydrogen has a very low density both as gas and as liquid. Hence in spite of its high calorific value on mass basis, its energy density as a liquid is only one fourth of that of gasoline.

Hydrogen has to be stored as compressed gas, as liquid (in cryogenic containers) or in absorbed form (as metal hydrides) none of which is convenient as gasoline storage.

An important point to be noted is the wide ignition limits of Hydrogen. Only 4% by volume of hydrogen in hydrogen-air mixture and 75% by volume of hydrogen in hydrogen-air mixture are both ignitable.

Hydrogen has a high self-ignition temperature, but requires very little energy to ignite it.

Hence it is very prone to pre-ignition and back flash in S.I. engines. The adiabatic flame temperature for hydrogen is a little lower than for gasoline but the rapid combustion allows very little heat loss to the surroundings and hence high, instantaneous, local temperatures are produced. This leads to high nitric oxide formation.

It can be seen from the above discussion that hydrogen has both advantages and disadvantages as an engine fuel. The engine system has to be adapted to take into account of these properties.

Hydrogen supplementation

Hydrogen can also be used as a supplement to gasoline in S.I. engines. In this system hydrogen is introduced along with gasoline, compressed and ignited by a spark.

The mass fraction of hydrogen lie over the test range. The heat contribution of hydrogen is however, much greater since the calorific value of hydrogen on mass basis is 2.8 times as high as that of iso-octane.

5.4.1 Hydrogen in S.I. Engines

Hydrogen can be used in S.I. engines by three methods:

1. by manifold introduction
2. by direct injection of hydrogen into the cylinder,
3. by supplementation to gasoline.

5.4.2 Use of hydrogen in C.L engines

There are two ways by which hydrogen can be used in diesel engines.

- (i) By introducing hydrogen with the air and using a spray of diesel oil to ignite the mixture - that is, by the Dual fuel mode.
- (ii) By injecting hydrogen directly into the cylinder at the end of compression. Since the self- ignition temperature of hydrogen is very high the gas spray is made to impinge on a hot glow plug in the combustion chamber - that is, by surface ignition.

The first method has the advantage of minimum modification of existing engines and is flexible with regard to the relative proportions of diesel oil and hydrogen. The second is suitable where an assured supply of hydrogen is available.

Advantages of hydrogen as a fuel

1. It is extremely clean burning. The main product of combustion is only water.
2. It can be produced from an abundant raw material, water and hence is renewable.
3. Many of its properties are highly suited to I.C. engines.

Disadvantages

1. Its energy density, either as a gas or as a liquid is quite low.
2. Since it is a highly reactive fuel, special safety precautions are necessary in handling it.
3. It can produce pre-ignition and back flash in engines, again due to its high reactivity.

5.5 ELECTRIC CAR

It is a natural fact that every automobile used for commercial purposes run by non-renewable source of energy. Moreover emission norms for automobiles are getting strict day by day and there seems to be no distinction between gasoline and diesel engines. Thus the search for alternative fuels for automobiles leads to the invention of electric cars which get the clean source of power from electric motor and can really lead to zero contamination during use.

The battery operated vehicles are popularly called as Electric vehicles (EV). All electric vehicles are non polluting, zero emission vehicles.

Electric cars use batteries to store energy needed to run the car. The lead-acid storage battery used in automobiles to start the engine is used in most electric cars. The

trouble with these batteries is that they are very heavy. And they will not provide enough electricity to run the car more than a few kilometers. That is after 80 k.m or so; the batteries need to be recharged. Driving an electric car is so easy and relaxed that it is in fact a pleasure even in the city stop and go traffic. With no clutch or gear, it drives like an automatic.

The vehicle is equipped with a scale of charge battery indicator, which is a fuel meter. It measures the remaining charge in batteries at any point of time. By reading the lighted bars on the fuel indicator the driver can ascertain the vehicle running time before it can be brought back to the charging bay for recharging. The vehicle is provided with a spacious 8 seater compartment for commuters, headlights, turning indicator lamps, dash board indicator, cabin light, tail lights, reverse light and name plate light.

Can be a Commercial Transit Van, School Van, Private Hotel Van, Jungle Safari Van etc.

Fuel – Batteries

Lead acid batteries are the most common type of batteries used in EV, because of their low initial cost and universal availability. There are many different types of sizes and designs, but the EV industry uses the deep cycle type, because they can tolerate repeated discharges. Deep cycle batteries are designed for repeated discharge of 80 % of capacity without serious damage. Shallower cycles will increase the life of any battery. The life expectancy is greatly shortened if the batteries are not fully recharged after every discharge cycles. Letting a battery remain discharged for any length of time will cause sulfation of the positive plates and a permanent loss of capacity.

But nowadays electric cars are not used practically for commercial purposes due to the necessity of expensive storage batteries.

Battery Charging

There is no need in queuing at petrol bunks. Just plug in, charge up and taking off is the simple way at it. The charging system is extremely simple, very reliable and safe. It has an on board charger along with a charge cable and can be charged anytime, anywhere - in the convenience of home or at workplace, by simply plugging in to a 220 volt, 15 Ampere household electrical socket. The battery attains 80% charge in less than two and half hours and full charge in less than six hours.

Salient features

Two computers and the state - of - the - art electronics in the electric vehicle provide an efficient energy management system with advanced computerised vehicle diagnostics.

The running chassis consists of a very strong, self supporting, light weight space frame and includes the motor, integrated power system, drive train, steering, suspension, brakes, wheels, tyres and high voltage systems. ABS (Acrylonitrile Butadiene Styrene) body panels are directly attached to the space frame of the running chassis.

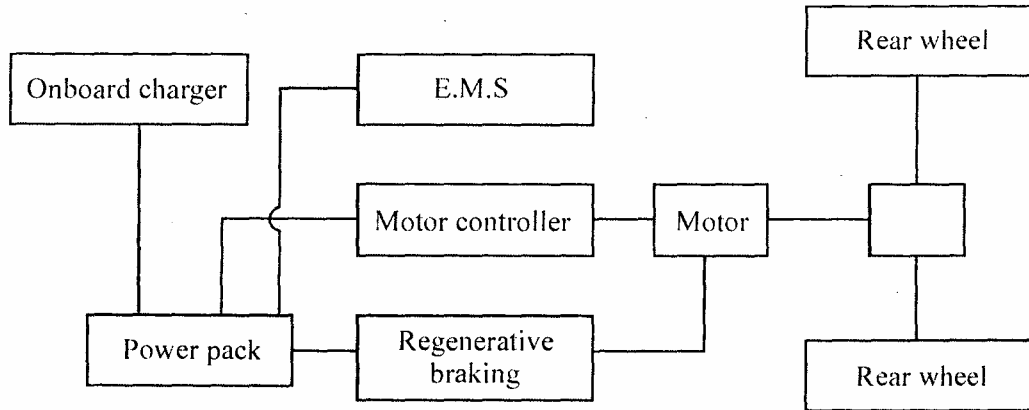

Figure 5.3 Power path of electric car

Working of electric vehicle

Electric vehicle mainly consists of the following components

1. Motor
2. Power pack
3. Onboard charger
4. Motor controller
5. Energy management system
6. Regenerative braking

Motor

The prime mover in electric vehicle is the motor. It is similar to the engine in a conventional car. It has a 13kW separately excited DC motor with a high torque of 70 Nm at zero speed. When in use, the motor converts the energy stored in the power pack into mechanical motion. The high torque electric motor ensures a quick acceleration. The power from the motor is delivered to wheels through the Trans-axle that propels the vehicle. While braking, the motor acts like a generator and recharges the power pack.

Power pack

Power pack consists of eight 6-volt EV tubular type lead acid batteries that attain 80% state of charge in under 2.5 hours. A complete charge is achieved in less than six hours. The power pack is housed beneath the front seats, which lowers the centre of gravity, thus increasing the safety of passengers. The battery power pack has a life of 3-5 years depending on usage.

Onboard charger

This converts AC into DC power to charge the power pack. The charger is computer controlled with an in - built stabilizer and auto shut - off mechanism. The smart charger's output is connected to the power pack and ensures that optimum current and voltage is maintained at all times.

Motor controller

This regulates the flow of energy from the power pack to the motor in direct relation to pressure applied on the accelerator. It ensures perfect speed control and optimum use of energy in both forward and reverse directions.

Energy management system

This monitors and controls all vital functions. The EMS is a computer based system that optimizes charging and energy output of batteries to maximize operating range and improve performance. The system also predicts available range for a given state of battery charge.

The EMS also maintain an electronic log of the vehicle performance, enables service personnel to run diagnostic checks on the car to give service information about the car.

Regenerative braking

Regenerative braking recovers useful electricity by putting it back into the batteries. Regenerative braking lets the motor act as a generator, converting the vehicle's momentum into electricity. So, when you take your foot off the accelerator or press the brake, the motor becomes a generator, slowing the car and returning energy to the battery.

Since it takes energy to make energy, the vehicle's momentum is consumed and the vehicle slows down. The immediate benefit of this process is that it simulates the compression braking (slow down effect) feature of gas engines, reducing the brake wear normal to most cars.

13. Being an electric vehicle, it is zero polluting and noiseless.
14. It does not require frequent oil changes.
15. This has high recyclable content.

5.5.2 Disadvantages of electric car

1. Batteries life is short, hence high replacement costs.
2. As the batteries are to be recharged the range is limited to about 60-70 km.
3. Need for the distribution of charging points.
4. More energy will be needed in the night to charge the batteries.
5. Unfavorable relationship between the weight of the energy storage system and the weight of the rest of the vehicle.
6. Inferior performance parameters like acceleration, drivability
7. Lesser autonomy than I C Engine driven cars

5.6 HYBRID VEHICLES - Introduction

Many alternative power sources and fuels are being investigated all over the world to meet the following requirements.

- Increased fuel efficiency
- Reduced emissions
- Increased acceleration capability
- Reduced noise emissions

The electric car in its present form does not represent a very easy option to use even though it is more environment friendly as compared to the I.C. Engine driven automobile. The immediate option seems to be to run an I.C. Engine in a better way so that it emits lower levels of pollutants and also uses lesser fuel. Another option seems to be to use fuel cell as a source of power. Low emissions are possible by using a combination of power sources i.e. a hybrid power pack. The hybrid can function as a pure electric vehicle for relatively short commutes while retaining the capability of a conventional automobile to make long trips.

5.6.1 Components and classification of hybrid vehicle

A hybrid vehicle uses both an internal combustion engine and a battery/ generator operated motor to run an automobile. The power of a hybrid's internal-combustion engine generally ranges from one tenth to one quarter that of a conventional automobiles. This engine can run continuously and efficiently and hence the Hybrid is much cleaner than a conventional car. With good design, moreover, HEVs can achieve several times the fuel efficiency of a gasoline-powered vehicle. In the hybrid vehicle the high thermal efficiency at which the engine can be operated to charge the batteries as compared to conventional automotive type operation leads to overall improved performance.

The main components of a hybrid drive train are the following:

1. An engine, considerably lesser in power capacity than an engine in a similar conventional automotive.
2. A motor/generator that may be on a common shaft on the engine output shaft or may be connected to the engine by a gear, belt, chain or other drive system.
3. A controller for the motor generator system. This must be efficient and capable of two way power control.
4. A storage device that can give short bursts of high output needed for acceleration etc and also be capable of long time energy supply for constant speed driving and operation of auxiliaries. Batteries, flywheels, fuel cells, cryogenic expander systems etc.
5. Differential and drive shaft.
6. Control circuits for the motor power controller, modified carburetor and engine throttle, sensors for vehicle speed, battery voltage, charge level.

Hybrid vehicles can be classified as follows:

1. **Series Hybrid** : Here the engine runs a motor directly and also charges a battery. Thus the motor thus drives the vehicle always. The motor can also be used for regenerative braking.
2. **Parallel Hybrid** : Here the I. C. Engine and the electric motor are coupled to the wheels in parallel. The engine runs at its optimal point and the motor supplements the torque of the engine. The motor can also be used for regenerative braking.

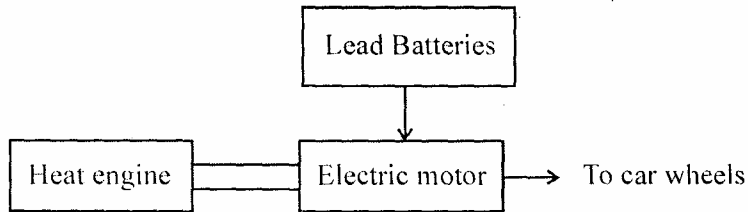
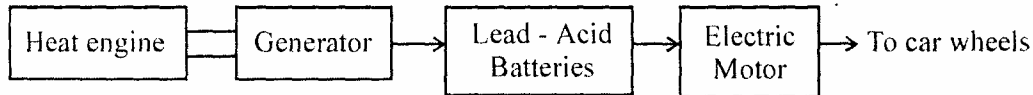

In order to achieve maximum efficiency and minimum emissions, a Hybrid vehicle can go through the following schedule and details :

- a) Prime mover is a turbocharged diesel engine.
- b) Under cruising conditions engine should be geared so as to operate to the best fuel conditions. The kinetic energy is absorbed by the vehicle during the acceleration.
- c) The potential energy absorbed by the vehicle while climbing up the hill has to be recovered while going down the hill by regenerative braking.
- d) Ideally the regenerative processes described in the modes c and d have to be reversible i.e. we should not use the brakes or the engine friction to decelerate the vehicle.
- e) The vehicle operation must be as reversible as possible to reduce fuel consumption.

5.6.2 Hybrid concept

In hybrid cars there are three main components,

1. An electric motor
2. A generator
3. Direct injection gasoline engine

The electric motor is used to supply power to the wheels. The electric motor derives its energy from *Nickel - Metal Hybrid battery or the Nickel - Cadmium* to drive the wheel and also from electric generator. The generator is used to give power and to the wheels there by to the electric motor.

The gasoline engine is used only when the electric battery fails to get recharged. It also depends upon the acceleration.

The fuel efficiency of the hybrid system is to be increased as the engine automatically switches off when the engine stops.

Types of Hybrid System

The hybrid system consists of two systems.

1. Parallel hybrid operation
2. Series hybrid operation
3. Series hybrid system

The I.C engine liberating the heat energy converts it to mechanical energy by using a gas turbine and runs an electric motor which controls the speed of the vehicle by giving drive to the vehicles.

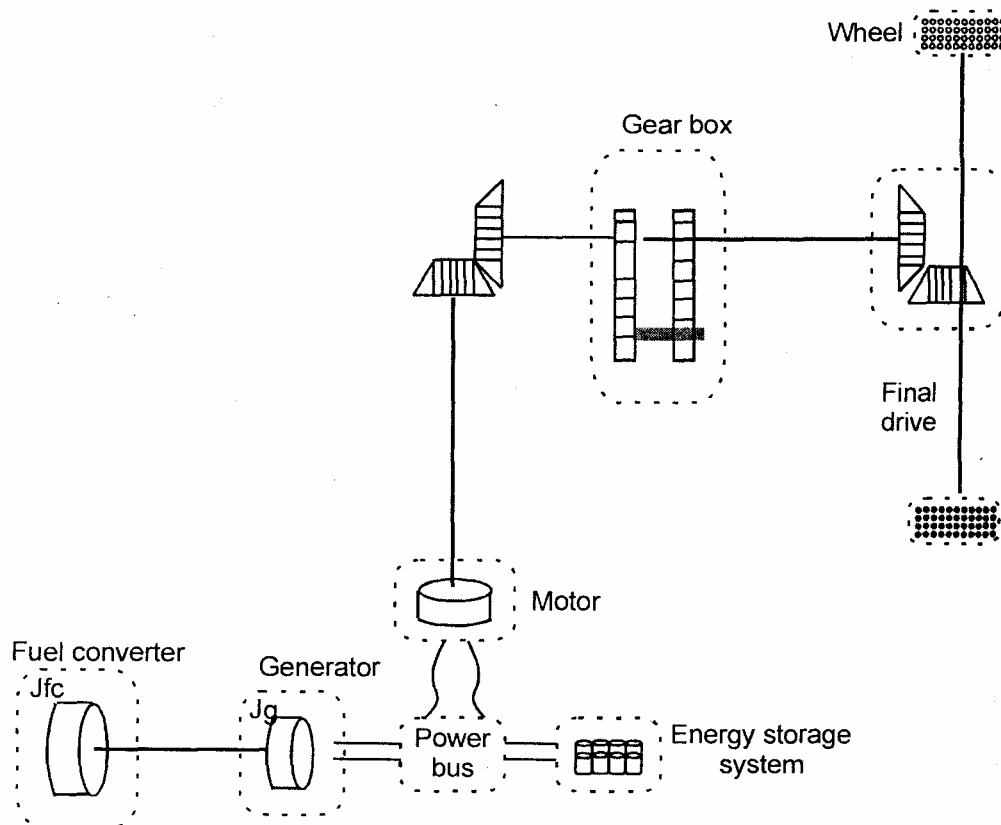

Figure 5.4 Series vehicle configuration hybrid system

Parallel drive train system

In the parallel hybrid version the engine and the motor are connected in parallel to obtain the required speed of vehicles. Under slow driving condition the motor can act in reverse as a generator for braking and to charge the batteries. The connectors are using sensors to detect the engine speed.

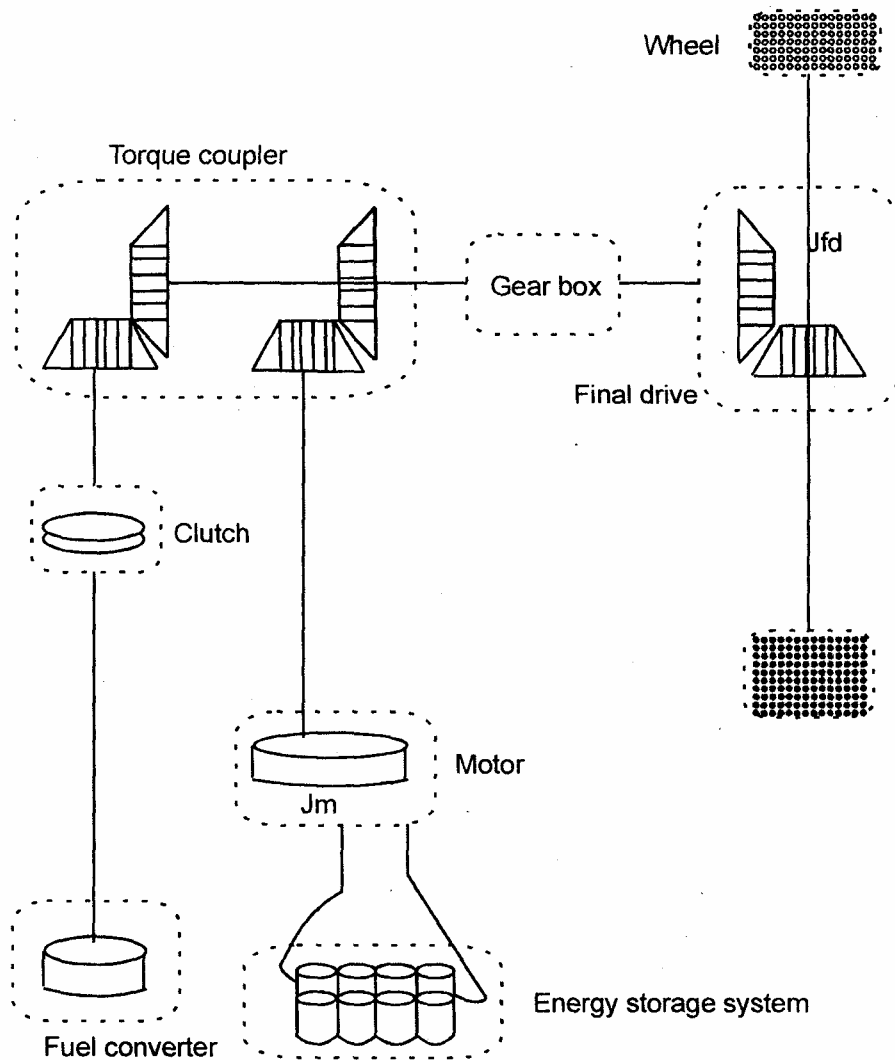

Figure 5.5 Parallel vehicle configuration

Advantages of hybrid system

1. Exceptionally low emission levels.
2. The cost of the engine is low as compared to that of installation of gas turbine and motor etc.,
3. Lesser fuel consumption

Disadvantages

1. It can be used for short distances only
2. The batteries cannot serve for or withstand to long distances.

5.7 FUEL CELL

A fuel cell is a device that harnesses the energy produced during the electro chemical reaction between hydrogen and oxygen. The products are water heat and electricity. There are no oxides of nitrogen, HC and Carbon monoxide.

Thus the use of the fuel cells can provide all the benefits of the battery and more along with extended range. They are also more efficient than the IC Engine.

Fuel cell automobile

Fuel cells are those cells which generate power to drive the vehicle using chemical reactions.

Need for fuel cells

The fuel cells have been developed due to the following reasons.

1. Depletion of conventional types of fuels leading to energy crisis.
2. Low emission required to make a car economic friendly.
3. To attain certain standards of emission control.

Fuel cell gases

The gases used for chemical fuel cells are Hydrogen and Oxygen. Though hydrogen gas is present in abundance in the atmosphere it causes serious difficulties for storing the fuel. Through a series of scientific development several storage devices are being developed. Hydrogen for example is stored in porous metals. The hydrogen when required is removed from these porous metal and then sent to for combustion. The oxygen is stored in cylinder in normal form of liquid.

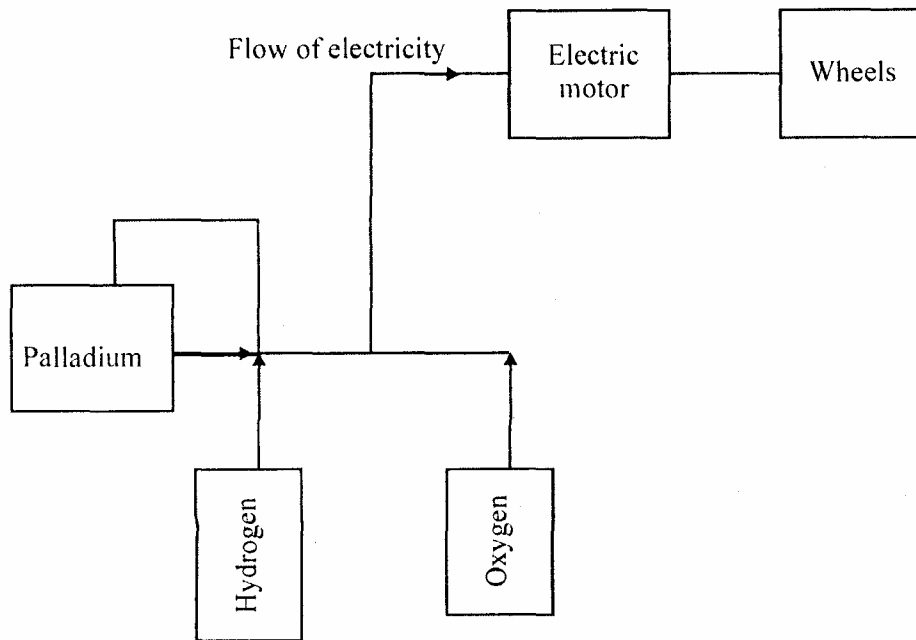

Figure 5.6 Fuel cell system

Fuel cell reaction

The hydrogen and oxygen combine in the presence of palladium to form water which generate electricity. The electricity generated is then used to run an electric motor. The end product of the reaction is water and it does not contain CO₂. The electric motor has sensors attached to the engine. When the engine decelerates, the sensors sensing the deceleration control the valve and opens the gas fuel cylinder valves.

Several hydrogen and oxygen filling stations have to be constructed which could be operated by man as well as robots. While filling at these stations, extra amount of oxygen is added. This is to prevent any suffocating inside the cars. When this occurs the oxygen air bags get dropped in.

Another interesting phenomena is that the carbon dioxide exhaled by the passengers inside a vehicle is collected by creating a vacuum. The collected carbon dioxide is then mixed with stemming water to form carbonated water. This carbonated water is collected in a tank and the water is disposed at a region where the hydrogen gas is filled. This is one of the most economic friendly gases.

Advantages of fuel cell

1. The fuel cell have very low emission of pollutants.
2. The oxygen air bags are very useful for the passengers.
3. The fuel cell prevents the depletion of the fossil fuel.
4. The carbon di oxide exhaled by the passengers is also removed.
5. Products are water, heat and electricity. There are no oxides of Nitrogen, HC and CO.
6. Provide all the benefits of the battery and more along with extended range.
7. More efficient than IC engine.
8. High efficiency and low emissions.

Disadvantages

1. Increased load capacity.
2. An elaborate storage methods for hydrogen have to be used.
3. Costly construction.