

WATER TECHNOLOGY

Syllabus: Hard Water – Estimation of hardness by EDTA method – Potable water- Sterilization and Disinfection – Boiler feed water – Boiler troubles – Priming and foaming , scale formation, corrosion, caustic embrittlement, turbine deposits – Softening of water – Lime soda, Zeolite processes – Reverse osmosis – Electro Dialysis, Ion exchange process

Objectives: For prospective engineers knowledge about water used in industries (boilers etc.) and for drinking purposes is useful; hence chemistry of hard water, boiler troubles and modern methods of softening hard water is introduced.

OUTLINES

- ❖ *Introduction*
- ❖ *Hardness of water*
- ❖ *Estimation of total hardness of water by EDTA method*
- ❖ *Scale and sludge formation in boilers*
- ❖ *Caustic embrittlement*
- ❖ *Boiler corrosion*
- ❖ *Priming and foaming*
- ❖ *Softening methods*
- ❖ *Potable water*
- ❖ *Desalination of brackish water*

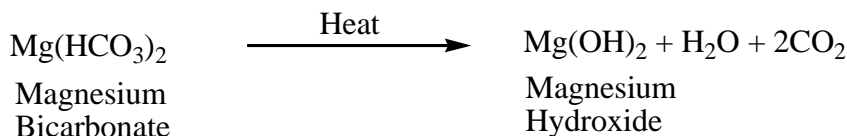

2.2 Permanent or non-carbonate hardness

This is due to the presence of chlorides and sulphates of calcium, magnesium iron and other heavy metals. Unlike temporary hardness, permanent hardness is not eliminated by simple boiling.

2.3 EQUIVALENTS OF CALCIUM CARBONATE

The concentration of hardness as well as non-hardness causing ions is usually expressed in terms of **equivalents of CaCO_3** , since this mode of representation permits the multiplication and division of concentration, when required. *The choice of CaCO_3 in particular is due to its molecular weight which is 100 and moreover, it is most insoluble salt that can be precipitated in water treatment.*

Table.1 Calculation of equivalents of calcium carbonate

Dissolved salt solution	Molar mass	Chemical equivalent	Multiplication factor converting into equivalents of CaCO_3
$\text{Ca(HCO}_3\text{)}_2$	162	81	100/162
$\text{Mg(HCO}_3\text{)}_2$	146	73	100/146
CaSO_4	136	68	100/136
CaCl_2	111	55.5	100/111
MgSO_4	120	60	100/120
MgCl_2	95	47.5	100/95
CaCO_3	100	50	100/100
MgCO_3	84	42	100/84
CO_2	44	22	100/44
$\text{Ca(NO}_3\text{)}_2$	164	82	100/164
$\text{Mg(NO}_3\text{)}_2$	148	74	100/148
HCO_3^-	61	61	100/122
OH^-	17	17	100/34
CO_3^{2-}	60	30	100/60
NaAlO_2	82	82	100/164
$\text{Al}_2(\text{SO}_4)_3$	342	57	100/114
$\text{FeSO}_4 \cdot 7\text{H}_2\text{O}$	278	139	100/278
H^+	1	1	100/2
HCl	36.5	36.5	100/73

$$\begin{aligned}
 \text{The equivalents of CaCO}_3 &= \frac{\left[\text{Mass of hardness producing substance} \right] \times \left[\text{Equivalent Weight of CaCO}_3 \right]}{\text{Equivalent Weight of hardness producing substance}} \\
 &= \frac{\text{Mass of hardness producing substance} \times 50}{\text{Equivalent Weight of hardness producing substance}}
 \end{aligned}$$

2.4 UNITS OF HARDNESS

1. **Parts per million (ppm)** is the parts of calcium carbonate equivalent hardness per 10^6 parts of water i.e., 1 ppm = 1 part of CaCO_3 eq. hardness in 10^6 parts of water.

2. **Milligram per liter (mg/L)** is the number of milligrams of CaCO_3 equivalent hardness present per liter of water,

Thus; 1mg/L= 1mg of CaCO_3 eq. hardness of 1 L of water

But 1 liter of water weighs 10^6 mg

1mg/L= 1mg of CaCO_3 eq. hardness in 10^6 parts of water

=1 part of CaCO_3 eq. hardness in 10^6 parts of water

1mg/L = 1 ppm

3. **Clarke's degree** is the number of grains (1/7000lb) of CaCO_3 equivalent hardness per gallon (10lb) of water or its parts of CaCO_3 equivalent hardness per 70,000 parts of water. Thus:

1° Clarke = 1 grain of CaCO_3 eq. hardness in gallon of water

1° Cl = 1 part of CaCO_3 eq. hardness in 70,000 parts of water

4. **Degree French** is the parts of CaCO_3 equivalent hardness per 10^5 parts of water.

Thus: 1°Fr = 1 part of CaCO_3 eq. hardness in 10^5 parts of water

5. **Milli equivalents per liter (meq/L)** is the number of Milliequivalents of hardness present per liter

Thus: 1 meq/L = 1 meq of CaCO_3 per liter of water

= 10^{-3} x 50g of CaCO_3 eq. per liter of water

= 50 mg of CaCO_3 eq. per liter

= 50 mg/L of CaCO_3 = 50ppm

6. **Relation between various units of hardness:**

1 ppm = 1 mg/L = 0.1° Fr = 0.07° Cl = 0.02 meq/L

1 mg/L = 1 ppm = 0.1° Fr = 0.07° Cl = 0.02 meq/L

1° Cl = 14.33° Fr = 14.3 ppm = 14.3 mg/L = 0.286 meq/L

0.1° Fr = 10 ppm = 10 mg/L = 0.7° Cl = 0.2 meq/L

1 meq/L = 50mg/L = 50 ppm = 5° Fr = 0.35 °Cl

3. Estimation of total hardness of water by EDTA method

This is a *complexometric method*. Ethylene diamine tetra acetic acid (EDTA)

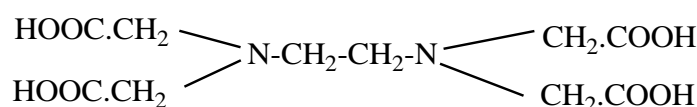

In the form of its salt yields the anion;

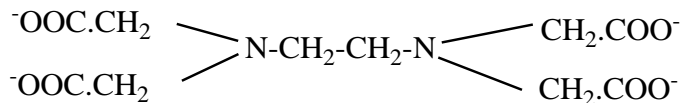

This forms complex ions with Ca^{2+} and Mg^{2+}

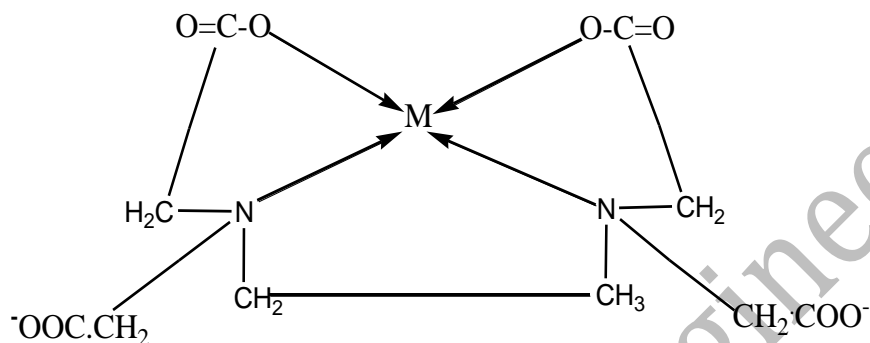

Where $M = \text{Ca}$ or Mg . It may be pointed that the EDTA is employed as its disodium salt,

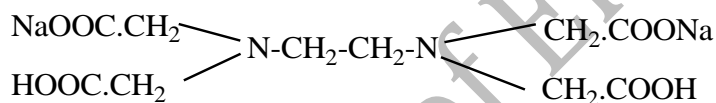

In order to determine the equivalence point, EBT (Eriochrome Black- T) indicator is employed, which forms unstable wine red complex with Ca^{2+} and Mg^{2+} ions. However, this indicator is effective at a pH of about 10. When EBT is added to hard water buffered to a pH of about 10, a wine red unstable complex is formed. Thus:

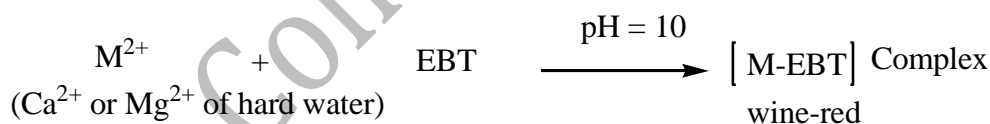

So initially a wine red coloured is obtained. During the course of titration against EDTA solution, EDTA combines with Ca^{2+} and Mg^{2+} ions and form stable complex M-EDTA and releasing free EBT, which instantaneously combines with M^{2+} ions still present in the solution, thereby wine red colour is retained thus:

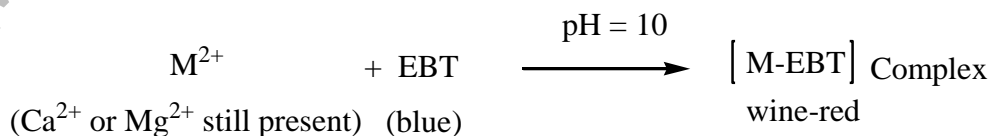
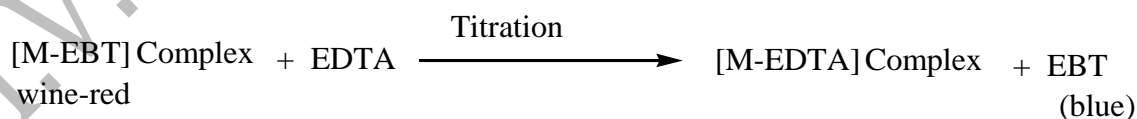

However, When nearly all M^{2+} (Ca^{2+} or Mg^{2+} ions) ions have formed [M-EDTA] complex, the next drop of EDTA added displaces the EBT indicator form [M-EBT] complex and the wine-red colour changes to blue colour. Thus, at the equivalence point,

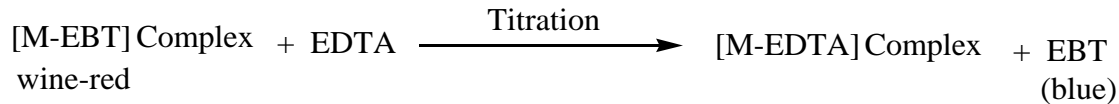

Thus change of wine red colour to a distinct blue marks the end of the titration.

1. **Standard hard water:** 1 gm of dry $CaCO_3$ is dissolved in minimum quantity of HCl and evaporate the solution to dryness on a water bath, and then diluted to 1 lit with water. Each ml of this solution then contains 1 mg of $CaCO_3$ hardness.
2. **EDTA solution** : 4 gm of EDTA crystals + 0.1 gm $MgCl_2$ in 1lit
3. **Indicator** : 0.5 gm of EBT in 100 ml of alcohol.
4. **Buffer solution** : 67.5 gm NH_4Cl + 570 ml of Con. Ammonia solution diluted with distilled water to 1 lit.
5. **Titration of permanent hardness of water:** Take 250 ml of the water sample in a large beaker .Boil till the volume is reduced to 50 ml. Filter, wash the precipitate with distilled water collecting filtrate and . Finally make the volume to 250 ml with distilled water. Then titrate 50 ml of the boiled water sample just as in step (5). Let volume used by V_3 ml

Calculations: 50 ml of standard hard water = V_1 ml of EDTA

$$\therefore 50 \times 1 \text{ mg of } CaCO_3 = V_1 \text{ ml of EDTA}$$

$$\therefore 1 \text{ ml of EDTA} = 50/V_1 \text{ mg of } CaCO_3 \text{ eq.}$$

Now 50 ml. of given hard water = V_2 ml EDTA

$$= V_2 \times 50/V_1 \text{ mg of } CaCO_3 \text{ eq.}$$

$$\therefore 1 \text{ L (1,000 mL) of given hard water} = 1000 V_2/V_1 \text{ mg of } CaCO_3 \text{ eq.}$$

$$\therefore \text{Total hardness of water} = 1000 V_2/V_1 \text{ mg/L}$$

$$= 1000 V_2/V_1 \text{ ppm}$$

Now 50 ml of boiled water = V_3 ml of EDTA

$$= \frac{V_3 \times 50}{V_1} \text{ mg of } CaCO_3 \text{ eq}$$

$$\therefore 1000 \text{ ml (= 1 L) of boiled water} = 1000 V_3/V_1 \text{ mg of } CaCO_3 \text{ eq}$$

$$\therefore \text{Permenent hardness} = 1000 V_3/V_1 \text{ ppm}$$

$$\text{And} \quad \text{Temporary hardness} = \text{Total hardness} - \text{Permanent hardness}$$

$$\begin{aligned}
 &= 1000 \left[\frac{V_2}{V_1} - \frac{V_3}{V_1} \right] \text{ ppm} \\
 &= \boxed{\frac{1000 (V_2 - V_3)}{V_1} \text{ ppm}}
 \end{aligned}$$

3.1 Advantages of EDTA method: This method is definitely preferable to the other methods, because of the (i) Larger accuracy; (ii) Convenience; (iii) Rapid procedure

3.2 Problems :

- 50 ml of sample consumed 15 ml of 0.01 M-EDTA before boiling and 5 ml of the same EDTA after boiling .Calculate the degree of total hardness, permanent hardness and temporary hardness.

Solution. 50ml of water sample = 15 ml of 0.01M-EDTA

$$\begin{aligned}
 &= \frac{15 \times 1000}{50} \text{ ml of 0.01 M-EDTA} = 300 \text{ ml of 0.01 M-EDTA} \\
 &= 2 \times 300 \text{ ml of 0.01 N-EDTA (Since Molarity of EDTA} = 2 \times \text{Normality of EDTA)} \\
 &= 600 \text{ ml (or 0.6 L) of 0.01 eq. CaCO}_3 \\
 &= 0.6 \times 0.01 \times 50 \text{ g eq. CaCO}_3
 \end{aligned}$$

Hence, total hardness = 0.30 g or 300 mg of CaCO₃ eq.
= 300 mg/L or 300 ppm.

Now 50 ml of boiled water = 5 ml of 0.01 M-EDTA

$$\begin{aligned}
 \therefore 1000 \text{ ml of boiled water} &= \frac{5 \times 1000}{50} \text{ ml of 0.01 M-EDTA} \\
 &= 100 \text{ ml of 0.01M-EDTA} \\
 &= 200 \text{ ml (or 0.2 L) of 0.01 N-EDTA} \\
 &= 0.2 \times 0.01 \times 50 \text{ g of CaCO}_3 \text{ eq.} \\
 &= 0.1 \text{ g or 100mg of CaCO}_3 \text{ eq.}
 \end{aligned}$$

Hence, permanent hardness = 100 mg/L or ppm

Temporary hardness = (300-100) ppm = 200 ppm.

- Calculate the total hardness of a sample of water containing Mg(HCO₃)₂ = 73 mg/L; Ca(HCO₃)₂ = 162 mg/L, MgCl₂ = 95 mg/L., CaSO₄ = 136 mg/L. **Ans. Total hardness of water: 350 ppm**

4. SCALE AND SLUDGE FORMATION IN BOILERS

In boilers, water evaporates continuously and the concentration of the dissolved salts increases progressively. *When their concentrations reaches saturation point, they are thrown out of water in the form of precipitates which stick to the inner walls of the boiler. If the precipitation takes place in the*

form of loose or slimy precipitate it is called **sludge**. On the other hand, if the precipitated matter forms a hard adhering crust/ coating on the inner walls of the boiler, it is a **scale**.

Sludge is a soft, loose and slimy precipitate formed within the boiler. Sludge can be easily scrapped off with a wire brush. It is formed at comparatively colder portions of the boiler and collects in areas of the system, where the flow rate is slow at bends. Sludges are formed by substances which have greater solubilities in hot water than in cold water. Examples are $MgCO_3$, $MgCl_2$, $CaCl_2$, $MgSO_4$ etc.

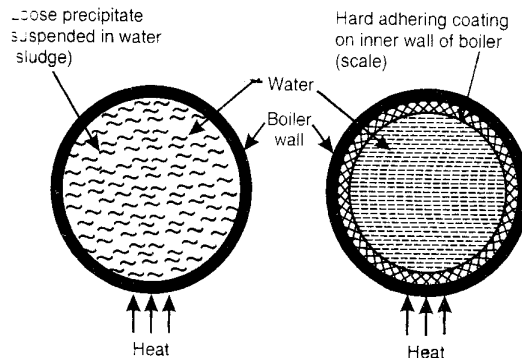

Fig.1. Scale and sludge in boilers.

4.1 Disadvantages of sludge formation:

1. Sludges are poor conductors of heat, so they tend to waste a portion of heat used.
2. If sludges are formed along with scales, the former get entrapped in the later and both get deposited as scales.
3. Excessive sludge formation disturbs the working of the boiler. It settles in the regions of poor water circulation such as pipe connection, plug opening, gauge glass connection thereby causing even chocking of the pipes.

4.2 Prevention of sludge formation:

1. By using well softened water.
2. By a frequent blow down operation, i.e., drawing off a portion of the concentrated water

Scales are hard deposits, which stick very firmly to the inner surface of the boiler. Scales are very difficult to remove even with the help of hammer and chisel. Scales are the main source of boiler troubles.

Formation of scales may be due to

1. *Decomposition of calcium bicarbonate*



However, scale composed chiefly of calcium carbonate is soft and is the main cause of scale formation in low pressure boilers. But in high pressure boilers $CaCO_3$ is soluble.

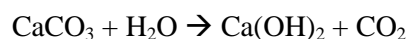

2. *Decomposition of calcium sulphate*: The solubility of calcium sulphate in water decreases with increase in temperature. Thus, solubility of calcium sulphate is 3,200 ppm at 15 °C and it reduces to 55 ppm at 230 °C and 27 ppm at 320 °C. In other words, calcium sulphate is soluble in cold water, but almost completely insoluble in superheated water. Consequently calcium sulphate gets precipitated as hard scale on the heated portions of the boiler. *This is the main cause in the high pressure boilers.*
3. *Hydrolysis of magnesium salts*: Dissolved magnesium salts undergo hydrolysis at prevailing high temperatures in the boiler forming magnesium hydroxide precipitate, which forms a soft type of scale.

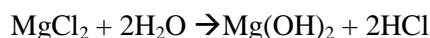

4. *Presence of silica*: (SiO_2), even if present in small quantities, deposits as calcium silicate (CaSiO_3) and/ or magnesium silicate (MgSiO_3). These deposits stick very firmly to the inner walls of the boiler surface and are very difficult for removal. One important source of silica in water is the sand filter used.

4.3 Disadvantages of scale formation:

1. **Wastage of fuels**: Scales have a *low thermal conductivity*, so the rate of transfer of heat from boiler to inside water is largely decreased. In order to provide a steady supply of heat to water, *excessive or over heating* is done which causes unnecessary increase in fuel consumption.

Thickness of the scale (mm)	0.325	0.625	1.25	2.5	12
Wastage of fuel	10%	15%	50%	80%	150%

2. **Lowering of boiler safety**: Due to scale formation, *over-heating* of the boiler has to be done in order to maintain a constant supply of steam. The over-heating of the boiler tube makes the boiler material *softer* and *weaker* and this causes *distortion of the boiler tube* and makes the boiler tube *unsafe* to bear the pressure of the steam especially in high-pressure boilers.
3. **Decrease in efficiency**: Scales may sometimes get deposited in the valves and condensers of the boiler and choke them partially or totally. This results in decrease the efficiency of the boiler.
4. **Danger of explosion**: When thick scales crack due to uneven expansion, the water comes in contact with the overheated iron plates. This causes a release of a large amount of steam suddenly, developing a high pressure, which may cause explosion in the boiler.

4.4 Removal of scales:

1. With the help of scraper or piece of wood or wire brush, if they are loosely adhering.
2. By giving thermal shocks like heating the boiler and suddenly cooling it with cold water.

3. Dissolving scales by adding suitable *chemicals*, if they are adherent and hard. Thus calcium carbonate scales can be dissolved by the addition of 5% HCl. Calcium sulphate scales can be dissolved by the addition of EDTA (ethylene diamine tetra acetic acid), with which they form complexes.
4. By frequent blow down operation, if the scales are loosely adhering.

5. CAUSTIC EMBRITTELEMENT

Caustic embrittlement is a type of boiler corrosion, caused by using highly alkaline water in the boiler. During softening process by lime- soda process, free sodium carbonate is usually present in small proportion in the softened water. In high pressure boilers, sodium carbonate decomposes to give sodium hydroxide and carbon dioxide, and their presence makes the boiler water caustic.

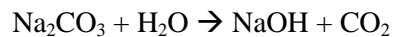

The water containing sodium hydroxide flows into the *minute* hair cracks always present, by capillary action in to the inner sides of the boiler. Here as water evaporates the dissolved caustic soda concentration increases progressively. This concentrated caustic soda attacks the surrounding area dissolving inner iron side of the boiler by forming *sodium ferroate*. This causes the embrittlement of the boiler parts, particularly stressed parts such as bends, joints, rivets etc., causing even failure of the boiler operations. Caustic cracking can be explained by the following concentration cell



The iron surrounded by the *dilute NaOH* becomes the cathodic surface and the iron present with the high concentration of NaOH becomes *anodic* which is consequently dissolved or corroded.

5.1 Caustic embrittlement can be avoided by

1. By using sodium phosphate as a softening agent instead of sodium carbonate.
2. By adding tannin or lignin to the boiler water, since these substances block the hair cracks, thereby preventing the infiltration of the caustic soda solution in to these.
3. By adding sodium sulphate to boiler water: Sodium sulphate blocks the hair cracks preventing the infiltration of caustic soda solution in to these. It has been observed that caustic cracking can be prevented, if sodium sulphate is added to the boiler in the ratio of $\text{Na}_2\text{SO}_4 : \text{NaOH}$ as 1:1; 2:1; 3:1 in boilers working respectively at pressures up to 10, 20 and above 20 atmospheres.

6. BOILER CORROSION

Boiler corrosion is the decay of boiler material (iron) either by chemical or electro chemical attack of its environment. Main reasons for the boiler corrosion are:

6.1 Dissolved oxygen: Water usually contains 8 mg of dissolved oxygen per liter at room temperature. Dissolved oxygen in water in the presence of prevailing high temperature of the boiler, attacks the boiler material as

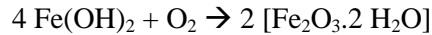
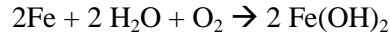

Removal of the dissolved oxygen:

a. By adding calculated amount of sodium sulphite or hydrazine or sodium sulphide.

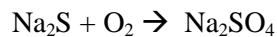
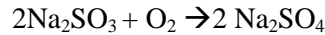

b. **Mechanical de-aeration:** In this process water is sprayed in to a tower fitted with perforated plates (Fig), heated from sides and connected to vacuum pump. High temperature, low pressure and large exposed surface area reduce the dissolved oxygen in water.

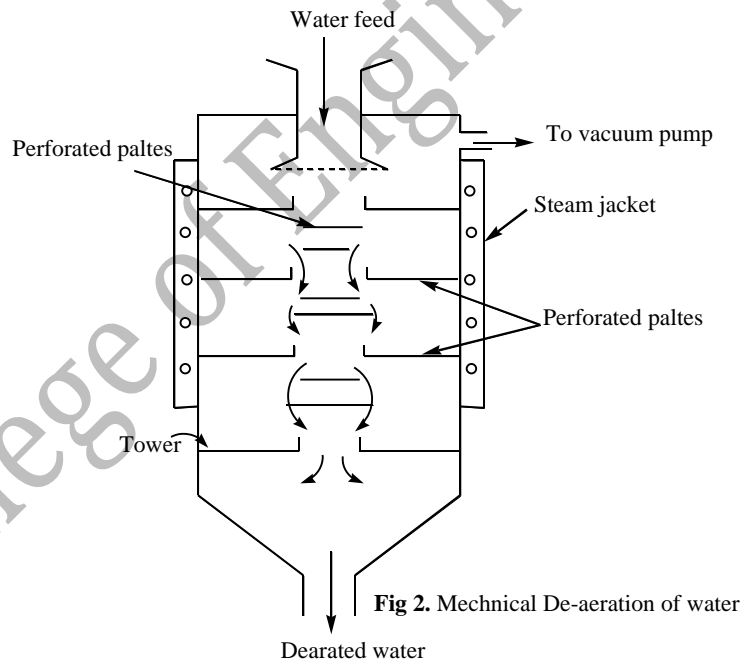

6.2 Dissolved carbon dioxide: Carbon dioxide dissolved in water forming carbonic acid, has a slow corrosive effect on the boiler material. Carbon dioxide is also released inside the boiler, if water, containing bicarbonates is used for steam generation



Removal of dissolved carbon dioxide:

a. By adding calculated amount of ammonia

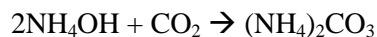

b. By mechanical de-aeration process along with oxygen (described above)

6.3 Acids from dissolved salts: Water containing dissolved salts of magnesium liberates acids on hydrolysis.



The liberated acid reacts with the iron material of the boiler in chain like processes, producing HCl again and again. Thus:

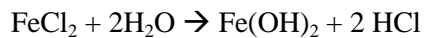
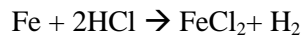

Consequently, presence of even small amount of magnesium chloride will cause corrosion to a large extent and may cause damage to the boiler material.

Removal of acids:

- a) Softening boiler water to remove magnesium chloride, if any.
- b) By frequent blow down operation of removal of concentrated water with fresh soft water.
- c) Addition of inhibitors as sodium silicate/sodium phosphate/sodium chromate, which protect the boiler material against acid attack.

7. PRIMING AND FOAMING

When a boiler is producing steam rapidly, some particles of the condensed liquid water are carried along with the steam. The process of wet steam formation is called priming. Priming is caused by

1. The presence of large amounts of dissolved solids
2. High steam velocities
3. Sudden boiling
4. Improper boiler design
5. Sudden increase in the steam production rate.

Foaming is the production of persistent foam or bubbles in boilers, which do not break easily. Foaming is due to the presence of substances like oils in water, which reduce the surface tension of water.

Priming and foaming usually occur together. They have to be eliminated because

- a. Dissolved salts in boiler water are carried by the wet steam to super heater and turbine blade, where they get deposited as water evaporates. This deposit reduces the efficiency of the boiler.
- b. Dissolved salts may enter the other parts of the machinery, where steam is being used, thereby decreasing the life of the machinery
- c. Actual height of the water column cannot be judged properly making the maintenance of the boiler pressure difficult.

Priming can be avoided by fitting mechanical steam purifiers, avoiding the rapid change in steaming rate, maintaining low water levels in boilers, efficient softening and filtration of the boiler feed water. Foaming can be avoided by adding anti foaming chemicals like castor oil, or removing oil from boiler water by adding compounds like sodium aluminate.

8. SOFTENING METHODS

Water used for industrial purposes (such as for steam generation) should be sufficiently pure. It should, therefore, be freed from hardness-producing salts before it is being put to use. *The process of removing hardness-producing salts from water is known as softening of water.* In industry three methods are mainly employed for softening of water.

8.1 Lime soda process: In this method, the soluble calcium and magnesium salts in water are chemically converted into **insoluble compounds**, by adding calculated amounts of lime [$\text{Ca}(\text{OH})_2$] and soda [Na_2CO_3]. Calcium carbonate [CaCO_3] and magnesium hydroxide [$\text{Mg}(\text{OH})_2$] are precipitated and removed. Exact amounts as required are calculated as below.

Table 2. Calculation of lime soda requirement

Constituent	Reaction	Need
Ca^{2+} (Perm.Ca)	$\text{Ca}^{2+} + \text{Na}_2\text{CO}_3 \longrightarrow \text{CaCO}_3 + 2 \text{Na}^+$	S
Mg^{2+} (Perm.Mg)	$\text{Mg}^{2+} + \text{Ca}(\text{OH})_2 \longrightarrow \text{Mg}(\text{OH})_2 + 2 \text{Ca}^{2+}$ $\text{Ca}^{2+} + \text{Na}_2\text{CO}_3 \longrightarrow \text{CaCO}_3 + 2 \text{Na}^+$	L+S
HCO_3^- (e.g., NaHCO_3)	$2\text{HCO}_3^- + \text{Ca}(\text{OH})_2 \longrightarrow \text{CaCO}_3 + 2\text{H}_2\text{O} + \text{CO}_3^{2-}$	L-S
$\text{Ca}(\text{HCO}_3)_2$ (Temp.Ca)	$\text{Ca}(\text{HCO}_3)_2 + \text{Ca}(\text{OH})_2 \longrightarrow 2\text{CaCO}_3 + 2\text{H}_2\text{O}$	L
$\text{Mg}(\text{HCO}_3)_2$ (Temp.Mg)	$\text{Mg}(\text{HCO}_3)_2 + 2\text{Ca}(\text{OH})_2 \longrightarrow 2\text{CaCO}_3 + \text{Mg}(\text{OH})_2 + 2\text{H}_2\text{O}$	2L
CO_2	$\text{CO}_2 + \text{Ca}(\text{OH})_2 \longrightarrow \text{CaCO}_3 + 2\text{H}_2\text{O}$	L
H^+ (Free acids, $\text{HCl}, \text{H}_2\text{SO}_4$, etc.)	$2\text{H}^+ + \text{Ca}(\text{OH})_2 \longrightarrow \text{Ca}^{2+} + 2\text{H}_2\text{O}$ $\text{Ca}^{2+} + \text{Na}_2\text{CO}_3 \longrightarrow \text{CaCO}_3 + 2 \text{Na}^+$	L+S
Coagulants : FeSO_4	$\text{Fe}^{2+} + \text{Ca}(\text{OH})_2 \longrightarrow \text{Ca}^{2+} + \text{Fe}(\text{OH})_2$ $2\text{Fe}(\text{OH})_2 + \text{H}_2\text{O} + \text{O}_2 \longrightarrow 2\text{Fe}(\text{OH})_3$	L+S
$\text{Al}_2(\text{SO}_4)_3$	$\text{Ca}^{2+} + \text{Na}_2\text{CO}_3 \longrightarrow \text{CaCO}_3 + 2 \text{Na}^+$ $2\text{Al}^{3+} + 3\text{Ca}(\text{OH})_2 \longrightarrow 3\text{Ca}^{2+} + 2\text{Al}(\text{OH})_3$ $3\text{Ca}^{2+} + 3\text{Na}_2\text{CO}_3 \longrightarrow 3\text{CaCO}_3 + 6\text{Na}^+$	L+S
NaAlO_2	$\text{NaAlO}_2 + \text{H}_2\text{O} \longrightarrow \text{NaOH} + \text{Al}(\text{OH})_3$ 2NaOH is eq to $\text{Ca}(\text{OH})_2$	-L

Now 100 parts by mass of CaCO_3 are equivalent to: (i) 74 parts of Ca(OH)_2 , and (ii) 106 parts of Na_2CO_3 .

$$\begin{aligned} \therefore \text{Lime requirement for softening} &= \frac{74}{100} \left[\text{Temp. Ca}^{2+} + 2 \times \text{Temp. Mg}^{2+} + \text{Perm. (Mg}^{2+} + \text{Fe}^{2+} + \text{Al}^{3+}) \right. \\ &\quad \left. + \text{CO}_2 + \text{H}^+ (\text{HCl or H}_2\text{SO}_4) + \text{HCO}_3^- - \text{NaAlO}_2 \text{ all in terms} \right. \\ &\quad \left. \text{of CaCO}_3 \text{ eq} \right] \\ \therefore \text{Soda requirement for softening} &= \frac{106}{100} \left[\text{Perm. (Mg}^{2+} + \text{Fe}^{2+} + \text{Al}^{3+} + \text{Ca}^{2+}) + \text{H}^+ (\text{HCl or H}_2\text{SO}_4) \text{ all} \right. \\ &\quad \left. \text{in terms of CaCO}_3 \text{ eq} \right] \end{aligned}$$

1. Calculate the amount of lime required for softening 50,000 liter of hard water containing $\text{CaCO}_3 = 25$ ppm, $\text{MgCO}_3 = 144$, $\text{CaCl}_2 = 111$ ppm, $\text{MgCl}_2 = 95$ ppm, $\text{Na}_2\text{SO}_4 = 15$ ppm, $\text{Fe}_2\text{O}_3 = 25$ ppm.

Constituent	Multiplication factor	CaCO_3 equivalent
$\text{CaCO}_3 = 25$	100/100	$25 \times 100 \times 100 = 25.0 \text{ mg/L}$
$\text{MgCO}_3 = 144$	100/84	$144 \times 100 \times 84 = 171.43 \text{ mg/L}$
$\text{CaCl}_2 = 111$	100/111	$111 \times 100 \times 111 = 100.0 \text{ mg/L}$
$\text{MgCl}_2 = 95$	100/95	$95 \times 100 \times 95 = 100.0 \text{ mg/L}$

Lime required for softening 50,000 L of water

$$\begin{aligned} &= 74/100 [\text{CaCO}_3 + 2 \times \text{MgCO}_3 + \text{MgCl}_2 \text{ as CaCO}_3 \text{ eq}] \times \text{Vol. of water} \\ &= 74/100 [25.0 + 2 \times 171.43 + 100] \text{mg/L} \times 50,000 \text{ L} \\ &= 74/100 [467.86 \text{ mg/L}] \times 50,000 \text{ L} = 1,73,10,820 \text{ mg} \\ &= (1.73, 10,820 \times 106) \text{ kg} = \mathbf{17.311 \text{ kg}} \end{aligned}$$

2. Calculate the quantity of lime and soda required for softening 50,000 liters of water containing the following salts per liter: $\text{Ca(HCO}_3)_2 = 8.1 \text{ mg}$; $\text{Mg(HCO}_3)_2 = 7.5 \text{ mg}$; $\text{CaSO}_4 = 13.6 \text{ mg}$; $\text{MgSO}_4 = 12.0 \text{ mg}$; $\text{MgCl}_2 = 2.0 \text{ mg}$; and $\text{NaCl} = 4.7 \text{ mg}$. **Ans 1.0134 kg (Lime); 0.9068 kg (Soda).**
3. A water sample contains the following impurities: $\text{Ca}^{2+} = 20 \text{ ppm}$, $\text{Mg}^{2+} = 18 \text{ ppm}$, $\text{HCO}_3^- = 183 \text{ ppm}$ and $\text{SO}_4^{2-} = 24 \text{ ppm}$. Calculate the amount of lime and soda needed for softening.

Ans. 166.5 ppm or mg/L (Lime): Negative or nil (Soda).

4. Explain with chemical and the amount of lime and soda needed for softening 1,00,000 liters of water containing the following :

$$\text{HCl} = 7.3 \text{ mg/L}; \text{Al}_2(\text{SO}_4)_3 = 34.2 \text{ mg/L}; \text{MgCl}_2 = 9.5 \text{ mg/L}; \text{NaCl} = 29.25 \text{ mg/L}$$

Purity of lime is 90% and that of soda is 98%. 10% of chemicals are to be used excess in order to complete the reaction quickly.

Ans. 4.522 kg. (Lime): 5.949 kg (Soda).

8.1.1 Cold Lime – Soda process: In this method, calculated quantity of chemicals (lime and soda) are mixed with water at room temperature. At room temperature, the precipitates formed are finely divided, so they do not settle down easily and cannot be filtered easily. Consequently, it is essential to add small amounts of coagulants (like alum, aluminium sulphate, sodium aluminates, etc.), which hydrolyse to flocculent, gelatinous precipitate of aluminium hydroxide, and are entrapped in the fine precipitates. Use of sodium aluminate as coagulant also helps the removal of silica as well as oil, if present in water. Cold L-S process gives water containing a residual hardness of 50 to 60 ppm.

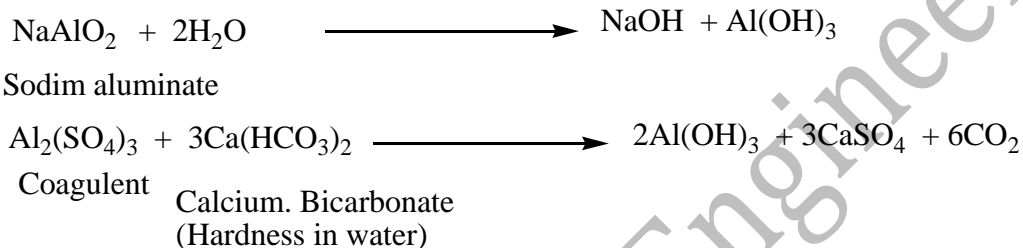

The details of the process are given below:

Method: Raw water and calculated quantities of chemicals (Lime + soda + coagulant) are fed from the top into the inner vertical circular chamber, fitted with a vertical rotating shaft carrying a number of paddles. As the mixture of raw water and chemicals flows down, there is a vigorous stirring and continuous mixing, whereby softening of water takes place. As the softened water comes into the outer co-axial chamber, it rises upwards to reach the filter.

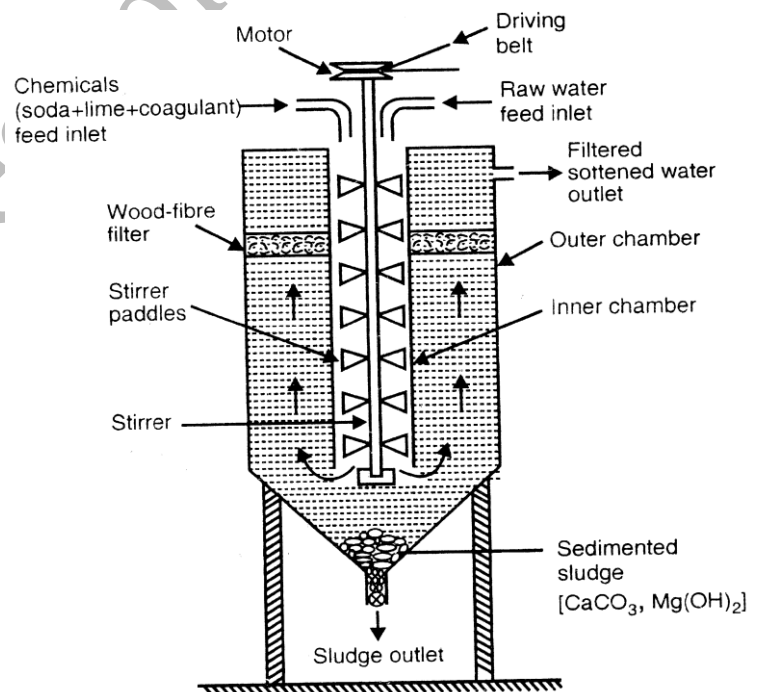

Fig. 3. Continuous cold lime soda softener.

The heavy sludge (or precipitated floc) settles down in the outer chamber by the time the softened water reaches up. The softened water then passes through a filtering media (usually made of wood fibers) to

ensure complete removal of sludge. Filtered soft water finally flow out continuously through the out let at the top (fig 3).Sludge setting at the bottom of the outer chamber is drawn off occasionally.

8.1.2 Hot Lime- Soda process: It involves in treating water with softening chemicals at a temperature of 80 to 150 °C. Since hot process is operated at a temperature close to the boiling point of the solution,

- (a) the reaction proceeds faster,
- (b) the softening capacity of hot process is increased to many fold and
- (c) the precipitate and sludge formed settle down rapidly and hence, no coagulants are needed.
- (d) Much of the dissolved gases (such as CO₂ and air) are driven out of the water.
- (e) Viscosity of softened water is lower, so filtration of water becomes easier. This in-turn increases the filtering capacity of filters, and
- (f) hot lime-soda process produces water of comparatively lower residual hardness of 15 to 30 ppm.

Hot lime- soda plant consists essentially (fig 4) of three parts: (a) a “ reaction tank” in which raw water, chemicals and steam are thoroughly mixed: (b) a “conical sedimentation vessel” in which sludge settles down and (c) a “ sand filter” which ensures complete removal of sludge from the softened water.

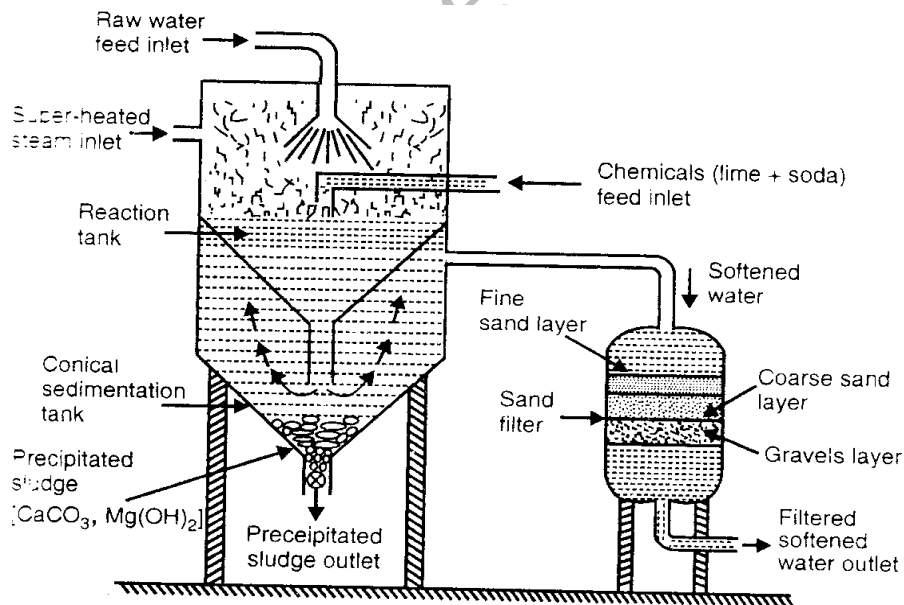

Fig. 4. Continuous hot lime-soda softener.

8.2 Zeolite or permutit process: Chemical structure of sodium zeolite may be represented as: $\text{Na}_2\text{O} \cdot \text{Al}_2\text{O}_3 \cdot x\text{SiO}_2 \cdot y\text{H}_2\text{O}$ where $x = 2-10$ and $y = 2-6$. Zeolite is hydrated sodium aluminosilicate, capable of exchanging reversibly its sodium ions for hardness-producing ions in water.

Zeolites are also known as permutits. **Zeolites are of two types:**

- (i) Natural zeolites are non-porous. For example, natrolite, $\text{Na}_2\text{O} \cdot \text{Al}_3\text{O}_3 \cdot 4\text{SiO}_2 \cdot 2\text{H}_2\text{O}$.
- (ii) Synthetic zeolites are porous and possess gel structure. They are prepared by heating together china clay, feldspar and soda ash. Such zeolites possess higher exchange capacity per unit weight than natural zeolites.

Process: For softening of water by zeolite process, hard water is percolated at a specified rate through a bed of Zeolite, kept in a cylinder (Fig. 5). The hardness-causing ions (Ca^{2+} , Mg^{2+} , etc.) are retained by the Zeolite as CaZe and MgZe ; while the outgoing water contains sodium salts. Reactions taking place during the softening process are:

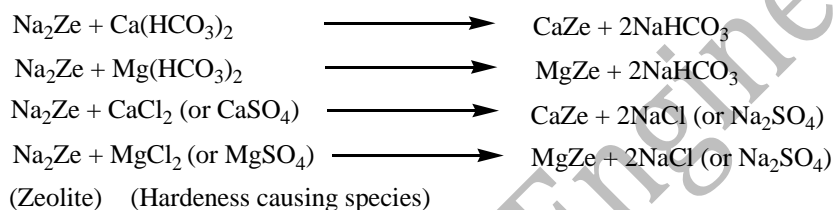

Regeneration: After some time, the zeolite is completely converted into calcium and magnesium zeolites and it ceases to soften water, i.e., it gets exhausted. At this stage, the supply of hard water is stopped and the exhausted zeolite is reclaimed by treating the bed with a concentrated (10%) brine (NaCl).

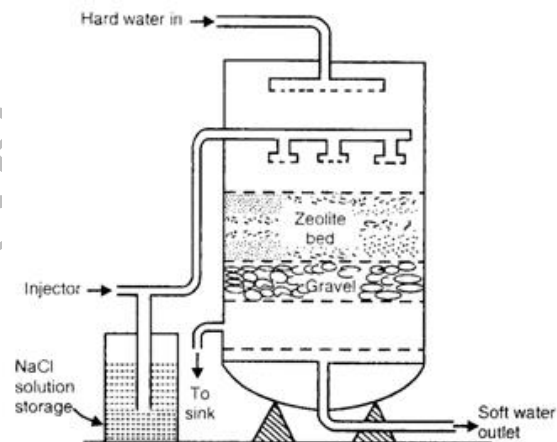
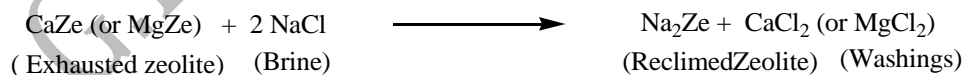

Fig. 5. Zeolite softener



8.2.1 Limitations of zeolite process:

- (1) If the supply of water is turbid, the suspended matter must be removed before the water is admitted into the zeolite bed; otherwise the turbidity will clog the pores of zeolite bed, making it inactive.
- (2) If water contains large quantities of coloured ions such as Mn^{2+} and Fe^{2+} , they must be removed first, because these ions produce manganese and iron zeolites, which will not allow easy regeneration of the zeolite.

- (3) Mineral acids, if present in water, destroy the zeolite bed and therefore they must be neutralized with soda, before admitting the water into the zeolite softening plant.

8.2.2 Advantages of zeolite process:

- (1) It removes the hardness almost completely and water of about 10 ppm hardness is obtained.
- (2) The equipment used is compact, occupying a small space
- (3) No impurities are precipitated, so there is no danger of sludge formation in the treated-water at a later stage.
- (4) The process automatically adjusts itself for variation in hardness of incoming water.
- (5) It is quite clean.
- (6) It requires less time for softening.
- (7) It requires less skill for maintenance as well as operation.

8.2.3. Disadvantages of zeolite process:

- (1) The treated-water contains more sodium salts than in the lime-soda process.
- (2) The method only replaces Ca^{2+} and Mg^{2+} ions, but leaves all the acidic ions in the soft water.
- (3) Water having high turbidity cannot be treated efficiently by this method.

8.3 Ion exchange or de-ionization or de-mineralization process: Ion-exchange resins are insoluble, cross-linked, long chain organic polymers with a microporous structure, and the “functional groups” attached to the chains are responsible for the ion-exchanging properties. Resins containing acidic functional groups ($-\text{COOH}$, $-\text{SO}_3\text{H}$ etc.) are capable of exchanging their H^+ ions with other cations, which come into their contact; whereas those containing basic functional groups ($-\text{NH}_2=\text{NH}$ as hydrochloric acid) are capable of exchanging their anions with other anions, which come into their contact. The ion-exchange resins may be classified as:

(i) **Cation exchange resins (RH^+)** are mainly styrene-divinyl benzene copolymers, which on sulphonation or carboxylation become capable to exchange their hydrogen ions with the cations present in the raw water.

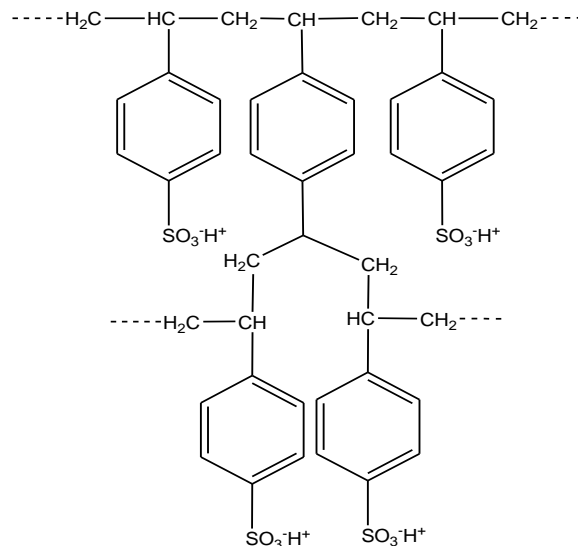

Acidic or cation exchange resin(sulphonate form)

(ii) **Anion exchange resins (R'OH⁻)** are styrene-divinyl benzene amine-formaldehyde copolymers, which contains amino or quaternary ammonium or quaternary phosphonium or tertiary sulphonium groups as an integral part of the resin matrix. These, after treatment with dil. NaOH solution, become capable to exchange their OH⁻ anions with anions present in the raw water.

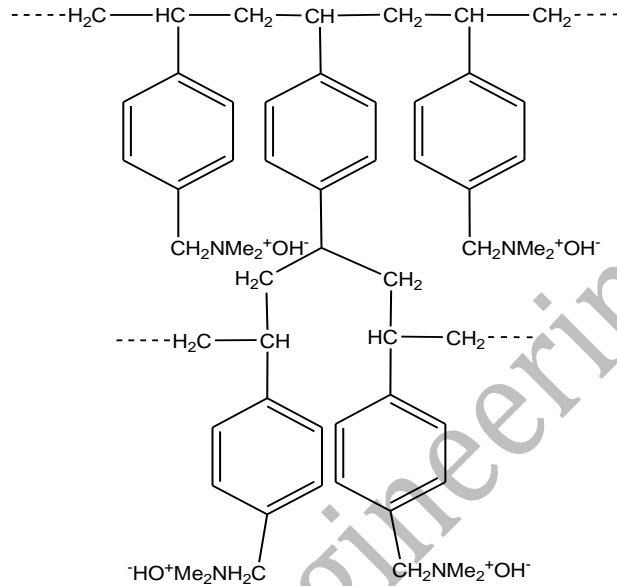

Basic or anion exchange resin(hydroxide form)

Process: The hard water is passed first through cation exchange column, which removes all the cations like Ca²⁺.Mg²⁺, etc., from it and an equivalent amount of H⁺ ions are released from this column to water. Thus:



The water which is now free from cations, is passed through anion exchange column, which removes all the anions like SO₄²⁻, Cl⁻ etc., present in the water and equivalent amount OH⁻ ions are released from this column to water. Thus:

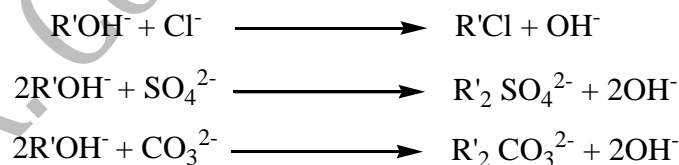

H⁺ and OH⁻ ions (released from cation exchange and anion exchange columns respectively) combine to produce water.

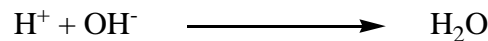

Thus the water coming out from the exchanger is free from all cations as well as anions. Ion-free water is known as deionised or demineralised water.

Regeneration: When capacities of cation and anion exchangers to exchange H⁺ and OH⁻ ions respectively are lost, they are then said to be exhausted.

The exhausted cation exchange column is regenerated by passing a solution of dil. HCl or H₂SO₄. The regeneration can be represented as:

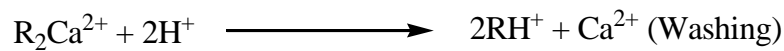

The column is washed with deionised water and such washing (which containing Ca²⁺, Mg²⁺, etc. and Cl⁻ or SO₄²⁻) is passed into sink or drain.

The exhausted anion exchange column is regenerated by passing a solution of dil. NaOH. The regeneration can be represented as:

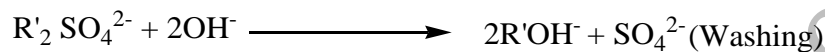

The column is washed with deionised water and such washing (which contains Na⁺ and SO₄²⁻ or Cl⁻ ions) is passed into sink or drain.

The regenerated ion exchange resins can be used again.

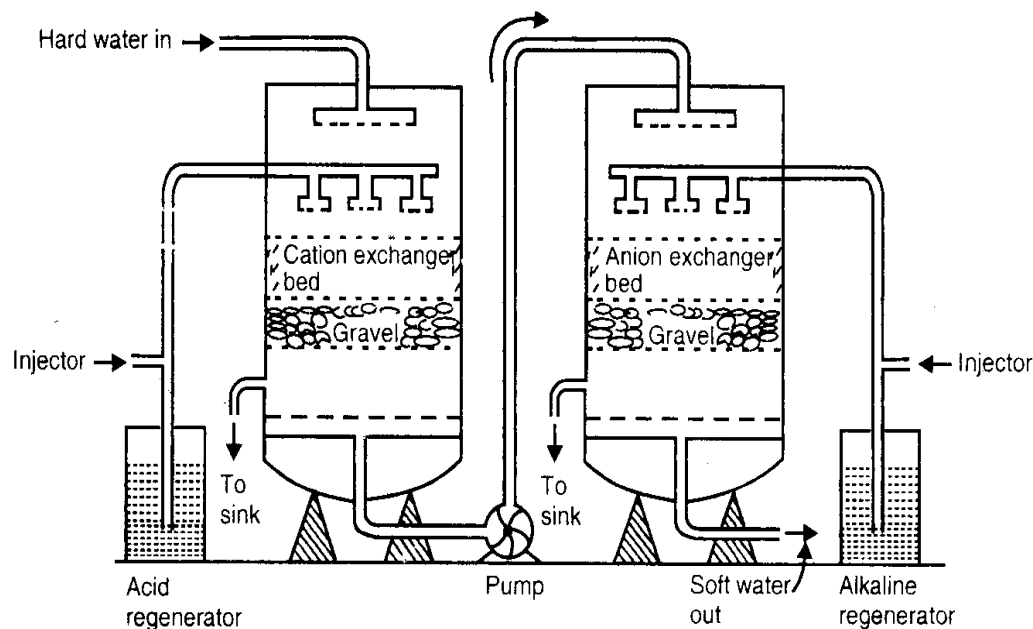

Fig. 6. Demineralization of water

Advantages

- (1) The process can be used to soften highly acidic or alkaline waters.
- (2) It produces water of very low hardness (2 ppm) .

Disadvantages

- (1) The equipment is costly and expensive chemicals are needed.
- (2) If water contains turbidity, then the output of the process is reduced.

- (3) The turbidity must be below 10 ppm. If it is more, it has to be removed first by coagulation followed by filtration.

9. Potable water

The water which is fit for human consumption is known as potable water

Municipalities have to supply potable water, i.e., water which is safe to human consumption should satisfy the following essential requirements

1. It should be sparkling clear and odourless.
2. It should be pleasant in taste
3. It should be perfectly cool
4. Its turbidity should not exceed 10 ppm
5. It should be free from objectionable dissolved gases like hydrogen sulphide.
6. It should be free from objectionable minerals such as lead, arsenic, chromium and manganese salts.
7. Its alkalinity should not be high. Its pH should not be above 8.0
8. It should be reasonably soft
9. Its total dissolved solids should be less than 500 ppm
10. It should be free from disease- producing micro- organisms.

Purification of domestic water for domestic use:

For removing various types of impurities in the natural water from various sources, the following treatment process is employed;

9.1 Removal of suspended impurities :

- a. **Screening:** The raw water is passed through screens, having large number of holes, when floating matter are retained by them.
- b. **Sedimentation:** It is the process of allowing water to stand undisturbed in big tanks, about 5 m deep, when most of the suspended particles settle down to the bottom, due to gravity. The clear supernatant water is then drawn from the tank with the help of pumps. The retention period in a sedimentation tank ranges from 2-6 hours.
- c. **Filtration:** It is the process of removing colloidal matter by passing water through a bed of fine sand and other proper – sized granular materials. Filtration is carried out by using sand filter.

9.2 Removal of micro-organisms:

The process of destroying /killing the disease producing bacteria, micro-organisms, etc., from the water and making it safe for the use, is called disinfection.

- a. **Boiling:** By boiling water for 10-15 minutes, all the disease producing bacteria is killed and the water becomes safe for use.
- b. **Adding bleaching powder:** In small water works, about 1 kg of bleaching powder per 1000 kiloliter of water is mixed and allowed to standing undisturbed for several hours.

The chemical action produces hypochlorous acid (a powerful germicide)

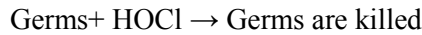
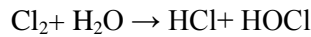
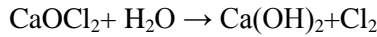

- c. **Chlorination:** Chlorination (either gas or in concentrated solution from) produces hypochlorous acid, which is a powerful germicide.

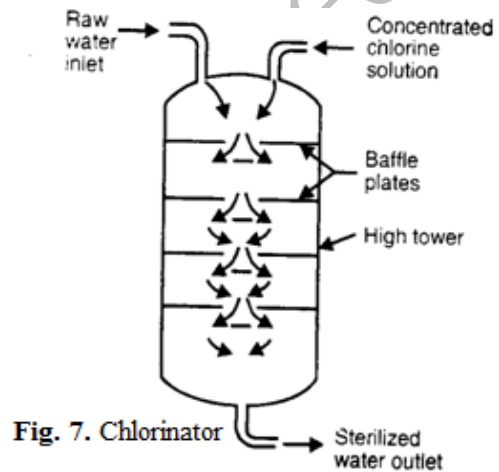
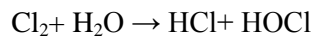

Fig. 7. Chlorinator

9.3. Break point chlorination

(or) **or free residual chlorination** :

It involves addition of sufficient amount of chlorine to oxidize: (a) organic matter (b) reducing substance and (c) free ammonia in raw water; leaving behind mainly free chlorine, which possesses disinfecting action against disease-producing bacteria.

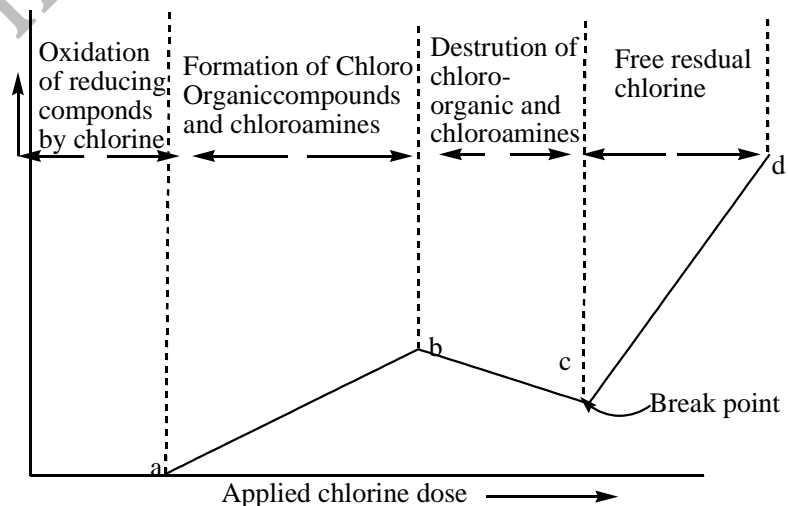

Fig 8. Break-point chlorination curve

The addition of chlorine at the dip or break is called “break point” chlorination. This indicates the point at which free residual chlorine begins to appear.

Advantages: (1) It oxidizes completely organic compounds, ammonia and other reducing compounds. (2) It removes color, odour and taste of water. (3) It removes completely all the disease causing bacteria/micro-organism (4) It prevents the growth of any weeds in water.

9.4. Using Chloramine (CINH₂): When chlorine and ammonia are mixed in the ratio of 2:1 by volume, chloramine is formed. $\text{Cl}_2 + \text{NH}_3 \rightarrow \text{CINH}_2 + \text{HCl}$

Chloramine is a better bactericidal than chlorine.

9.5. Disinfection by Ozone: Ozone gas is an excellent disinfectant, which is produced by passing silent electric discharge through cold and dry oxygen. $3\text{O}_2 \rightarrow 2\text{O}_3$

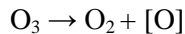

10. Desalination of brackish water

The process of removing common salt (NaCl) from the water is known as desalination. Water containing high concentration of dissolved salts with a peculiar salty taste is called brackish water. Sea water is an example containing 3.5% of dissolved salts. The common methods for the desalination of brackish water are;

10.1 Eletctrodialysis: It is a method in which the ions are pulled out of the salt water by passing direct current, using electrodes and thin rigid plastic membrane pair.

An *Eletctrodialysis cell* (**Fig. 9.**)

consists of a large number of paired sets of rigid plastic membranes. Hard water is passed between the membrane pairs and an electric field is applied perpendicular to the direction of water flow. Positively charged membrane and negatively charged membrane repel positively charged ions and negatively charged ions respectively to pass through. So, in one compartment of the cell, the salt concentration decreases while in the adjacent compartment it increases.

Thus, we get alternative stream of pure water and concentrated brine.

Advantages: 1. It is most compact unit.

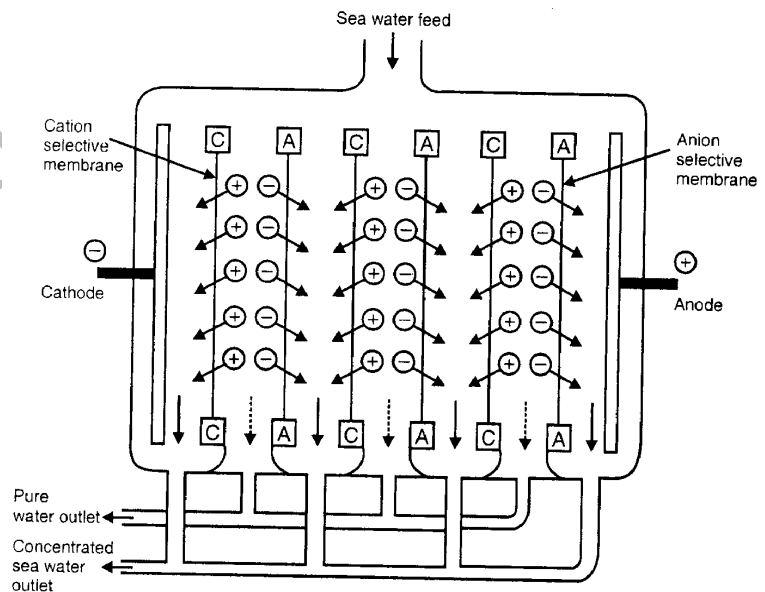

Fig. 9. Eletctrodialysis cell

2. The cost of the plant and its operation is economical.

10.2 Reverse osmosis: When two solutions of unequal concentrations are separated by a semi permeable membrane, flow of solvent takes place from dilute to concentrate sides, due to osmosis. If, however a hydrostatic pressure in excess to osmotic pressure is applied on the concentrated side, the solvent flow is reversed, i.e, solvent is forced to move from concentrated side to dilute side across the membrane. This is the principle of reverse osmosis.(RO)

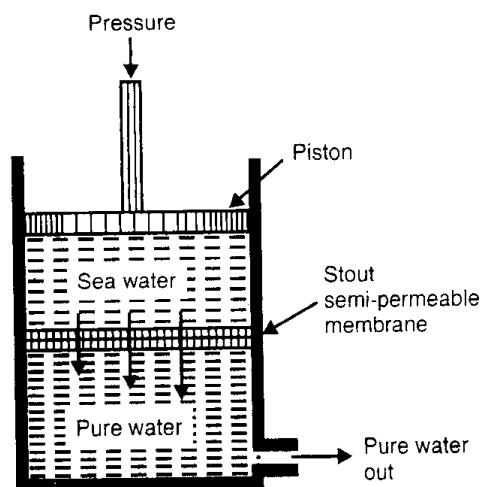

Fig. 10. Reverse Osmosis cell

Thus in reverse osmosis method, pure solvent is separated from its contaminants, rather than removing contaminants from the water. The membrane filtration is sometimes also called super-filtration or hyper-filtration.

Method: In this process, pressure is applied to the sea water or impure water to force the pure water content of it out the semi-permeable membrane, leaving behind the dissolve solids. The principle of reverse osmosis as applied for treating saline/sea water as illustrated in **fig 10**. The membrane consists of very thin film of cellulose acetate, affixed to either side of a perforated tube. However, more recently superior membranes made of polymethacrylate and polyamide polymers have come into use.

Advantages

1. Reverse osmosis possesses distinct advantages of removing ionic as well as non-ionic, colloidal and high molecular weight organic matter.
2. It removes colloidal silica, which is not removed by demineralization.
3. The maintenance cost is almost entirely on the replacement of the semi permeable membrane.
4. The life time of membrane is quite high, about 2 years,
5. The membrane can be replaced within a few minutes, thereby providing nearly uninterrupted water supply.
6. Due to low capital cost, simplicity, low operating cost and high reliability, the reverse osmosis is gaining grounds at present for converting sea water into drinking water and for obtaining water for very high –pressure boilers.

Assignment Questions

1.
 - a) Discuss the impurities in water and their effects
 - b) Describe the demineralization of water by ion-exchange method
 - c) Mention the disadvantages of using hard water for any two industries.
2.
 - a) What is the principle of EDTA method? Explain the estimation of hardness of water by Complexometric method
 - b) Write a short note on priming and foaming, phosphate conditioning and caustic Embrittlement
 - c) Write short note on break-point chlorination and dissolved oxygen, Hardness of water, sedimentation and coagulation.
3.
 - a) Explain scale and sludge formation in boilers. What are their disadvantages? How are they removed?
 - b) Describe the method to determine various alkalinities in a given sample of water. What do you mean by hardness of water? How is it classified? Mention the disadvantages of using hard water for domestic purpose.
4.
 - a) What are the specifications of potable water? Discuss the various steps involved in the treatment of water for domestic purpose.
5.
 - b) What are the chemical reactions involved in the conditioning water by lime soda process? Explain the hot lime soda process with a neat diagram.
6. 0.05g of calcium carbonate was dissolved in dilute HCl and diluted to 1000ml. 50 ml of this solution requires 48ml of EDTA solution for titration. 50 ml of hard water samples require 15 ml of EDTA solution for titration. 50 ml of same water sample on boiling, filtering, require 10ml EDTA solution. Calculate the different kinds of hardness in ppm.
7. Water having following composition to be softened by lime soda process
Calcium bicarbonate = 220ppm; magnesium bicarbonate = 56 ppm, magnesium chloride = 130ppm, magnesium sulphate = 84ppm, calcium sulphate = 98 ppm. Calculate the amount of lime and soda required to soften million liters of water.
8. Write a note on mechanical deaeration? What are the requirements of boiler feed water?
9. What are ion exchange resins? Discuss their applications in water softening.